

AD724611



AD

Research and Development Technical Report

ECCOM-6050

A COMPUTER METHOD
FOR RETRIEVING INFORMATION
ON ARTICLES, REPORTS, AND PRESENTATIONS

By

ERNEST B. STENMARK

September 1970

DDC
RECEIVED
JUN 15 1971
R
C

This document has been approved for public release and sale; its distribution is unlimited

ECCOM

UNITED STATES ARMY ELECTRONICS COMMAND
ATMOSPHERIC SCIENCES LABORATORY
FORT HUACHUCA, ARIZONA

Reproduced by
NATIONAL TECHNICAL
INFORMATION SERVICE
Springfield, Va. 22151

42

UNCLASSIFIED

Security Classification

DOCUMENT CONTROL DATA - R & D		
<i>(Security classification of title, body of abstract and indexing annotation must be entered when the overall report is classified)</i>		
1. ORIGINATING ACTIVITY (Corporate author) Atmospheric Sciences Laboratory U. S. Army Electronics Command Fort Huachuca, Arizona 85613		2a. REPORT SECURITY CLASSIFICATION Unclassified
		2b. GROUP
3. REPORT TITLE A COMPUTER METHOD FOR RETRIEVING INFORMATION ON ARTICLES, REPORTS, AND PRESENTATIONS.		
4. DESCRIPTIVE NOTES (Type of report and inclusive dates)		
5. AUTHOR(S) (First name, middle initial, last name) Ernest R. Stenmark		
6. REPORT DATE September 1970	7a. TOTAL NO. OF PAGES 39	7b. NO. OF REFS
8a. CONTRACT OR GRANT NO.	8b. ORIGINATOR'S REPORT NUMBER(S) ECOM-6050	
8c. PROJECT NO.		
8d. DA Task No. 1T061102B53A-17	8e. OTHER REPORT NO(S) (Any other numbers that may be assigned this report)	
8e.		
10. DISTRIBUTION STATEMENT This document has been approved for public release and sale; its distribution is unlimited.		
11. SUPPLEMENTARY NOTES	12. SPONSORING MILITARY ACTIVITY Atmospheric Sciences Laboratory U. S. Army Electronics Command Fort Huachuca, Arizona 85613	
13. ABSTRACT A FORTRAN language computer program has been written to permit selective information retrieval from listings of reports, articles, and presentations maintained as a computer card master file and on magnetic tape as a working file. The program features a simple, routine method for updating both files, and completely flexible, automatic extraction of specific listings according to such criteria as type, origin, date, date of entry to the file, and subject category.		

DD FORM 1473
1 NOV 66

REPLACES DD FORM 1473, 1 JAN 66, WHICH IS OBSOLETE FOR ARMY USE.

UNCLASSIFIED

Security Classification

UNCLASSIFIED

Security Classification

14 KEY WORDS	LINK A		LINK B		LINK C	
	ROLE	WT	ROLE	WT	ROLE	WT
Computer programs Information retrieval						

UNCLASSIFIED

Security Classification

TR ECOM-6050
September 1970

Reports Control Symbol
OSD-1366

A COMPUTER METHOD
FOR
RETRIEVING INFORMATION
ON
ARTICLES, REPORTS, AND PRESENTATIONS

By
Ernest B. Stenmark

DA Task No. 1T061102B53A-17

Atmospheric Sciences Research Technical Area
Atmospheric Sciences Laboratory
U.S. Army Electronics Command
Fort Huachuca, Arizona

This document has been approved for public re-
lease and sale; its distribution is unlimited.

ABSTRACT

A FORTRAN language computer program has been written to permit selective information retrieval from listings of reports, articles, and presentations maintained as a computer card master file and on magnetic tape as a working file. The program features a simple, routine method for updating both files, and completely flexible, automatic extraction of specific listings according to such criteria as type, origin, date, date of entry to the file, and subject category.

CONTENTS

	Page
Abstract	111
Introduction	1
Background	1
Approach	1
Figure 1. Selective listing options	4
Program Descriptions	5
Annexes:	
A. New entry card set preparation	7
B. Code card preparation	9
C. "Update" data deck setup	13
D. Extract card coding	17
E. Program flow charts	21
F. Program listings	31

A COMPUTER METHOD FOR RETRIEVING INFORMATION ON ARTICLES, REPORTS, AND PRESENTATIONS

I. INTRODUCTION

The objectives of this effort were to improve procedures for maintaining up-to-date listings of all articles, oral presentations, and reports published by or for the Atmospheric Sciences Research Technical Area (ASRTA); to make periodic updating of such lists as routine and easy as possible; and to make the preparation of selective lists an automatic machine procedure.

II. BACKGROUND

Over the past years, the list of published articles, oral presentations, and published reports originating either internally within ASRTA or externally with contractors and other research groups associated with ASRTA has grown quite rapidly. Along with the growth of the number of such items has come an increasingly frequent need to prepare selective listings of these items according to type, origin, time period, time of entry into the file, subject category, or some combination of these criteria. Compiling such listings by hand from a typed master list had become a time-consuming task, as had the periodic updating of the typed master list.

The project was therefore undertaken to reduce the typed master list to a computer card file of information which could be copied to a magnetic tape working file and then listed by computer, either fully or in selected parts.

III. APPROACH

A. Items included in the original typed listings had been arranged chronologically within six categories:

1. Articles published by ASRTA personnel in scientific journals and conference proceedings.
2. Presentations by ASRTA personnel at technical meetings.
3. Reports by ASRTA personnel for general DOD distribution.
4. Articles published by contractors in scientific journals and conference proceedings.
5. Reports by contractors for Army use.
6. Reports by ASRTA personnel for internal use or limited distribution.

B. In order to gain slightly more flexibility in selective listings, the sequence of these categories was changed somewhat and one additional category was created:

1. Articles published by ASRTA personnel in scientific journals and conference proceedings.
2. Presentations by ASRTA personnel at technical meetings.
3. Reports by ASRTA personnel for general DOD distribution.
4. Reports by ASRTA personnel for internal use or limited distribution.
5. Articles published by contractors in scientific journals and conference proceedings.
6. Reports by contractors for ASRTA general distribution.
7. Reports by contractors for ASRTA limited distribution or internal use.

Individual entries of any of these given types are kept in chronological order. Each entry is identifiable by date (year and month), origin (internal or external), type (article, presentation, or report), and, if applicable, by type of distribution (general or limited). Entries are further identifiable by one or more of nine subject categories and by date of entry into the file.

C. In transferring this information to computer cards, two separate decks of cards were prepared, an information deck and a code card deck.

D. The information deck is made up of seven sections, one for each of the general types listed in (B) above. Each section contains one 6-unit set of cards for each item in the section. The first card of each set contains one 4-digit identification or entry number, which identifies the section and the entry location within the section. All entry numbers pertaining to items in section 1 are coded as 1001, 1002, through 1nnn where "nnn" is the last entry number in the section. Section 2 items are coded in the 2000's, section 3 in the 3000's, etc.

E. The remaining five cards in each information set contain the plain language description of the item, e.g., author's name, title of the publication or presentation, contract or report number, date of publication or presentation. Since this information is all read-in and then written-out of the computer under FORTRAN A-conversion, no rigid format is required. The only limitations are that the complete set of information must fit on five 80-column IBM cards, and that five

cards always be used. Up to four of the set of five cards may be completely blank, depending on the amount of information available.

F. The first 6-card set in each section contains a written description of the type of entry in the section. This information is used to print out the heading to each separate section within a listing.

G. The code card deck is made up of one card for each entry within the information deck; it is therefore only one-sixth the size of the information deck. Each code card contains from six to eleven items of data which key directly back to the corresponding entry within the information deck. These items of data are the date (four digits giving year and month); origin (internal or external); type of entry (article, presentation, or report); and entry number (corresponding to the number of the first card of each 6-card set in the information deck). A fifth piece of data refers only to report entries and describes the type of distribution, whether general or limited. The sixth data item is the process date or date of entry to the file. The seventh through eleventh data items are the subject categories pertinent to the entry. Each entry may reference from one to five subjects.

H. Preparation of a set of cards for a new entry is summarized in Annex A. Details of preparing the code card are given in Annex B.

I. FORTRAN IV was chosen as the programming language for this project for two reasons. First, FORTRAN is the most widely used scientific programming language; second, the logical decision options available in FORTRAN IV make possible a relatively short, simple program having considerable flexibility for selective listing.

J. Lists obtainable from the selective listing program can be as comprehensive as a listing of the entire information deck, i.e., all types of items from all origins for all periods of time, or as specific as, for example, a listing of only those items identified as externally originating reports prepared for limited distribution and published during a particular period of time. An option has also been included which allows listing of any number of arbitrarily selected items specified by a prepared list of entry numbers. Figure 1 illustrates the selective listing options available.

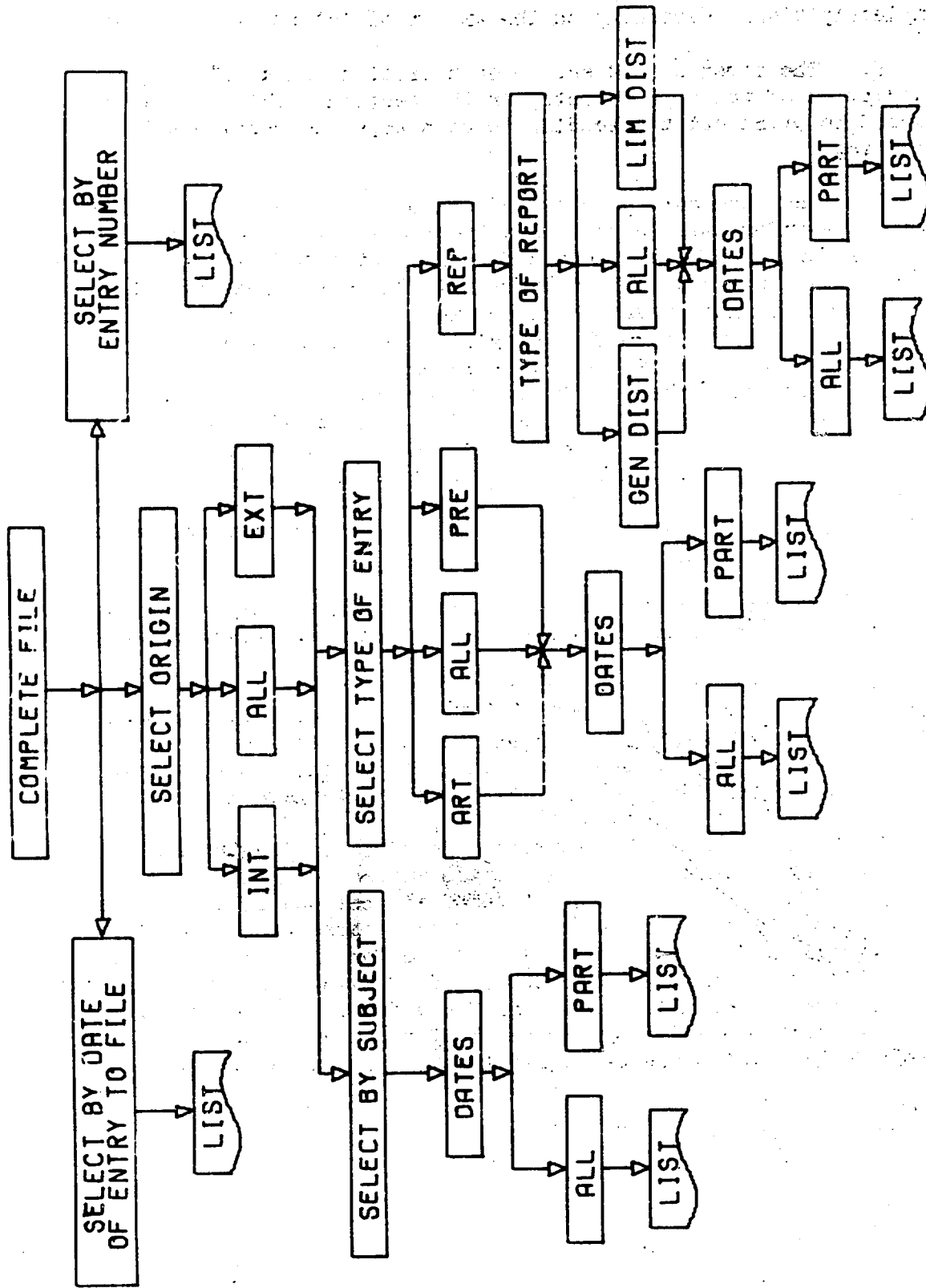

FIGURE 1. SELECTIVE LISTING OPTIONS

IV. PROGRAM DESCRIPTIONS

A. Three separate programs have been written for use in this information retrieval system.

B. Program "SELIST" copies the entire master file of computer cards to magnetic tape. "SELIST" is used to initially create the working file and to subsequently re-create the working file if it should for any reason become unreadable; e.g., through accidental scratching of the tape, parity errors induced by wear or mishandling of the tape, etc.

C. Program "UPDATE" creates a new working file from the existing working file with corrections, additions, or deletions of information at any location within either the code card or information deck sections of the file. "UPDATE" is routinely employed once a month to insert new entries into the working file and to obtain a check listing of the entire updated file. It may also be used on a non-routine basis at any time to correct or delete information from the working file. The data deck setup for "UPDATE" is outlined in Annex C.

D. Additions, corrections, or deletions to the master card file are made manually using for reference the check listing prepared by "UPDATE".

E. Specific listings are obtained from the working file through the use of program "SELIST". The specifications for each required listing are made available to "SELIST" through individually prepared "EXTRACT" data cards. The coding and format of the "EXTRACT" cards are given in Annex D. Multiple listings of identical or differing content may be obtained from one execution of program "SELIST" by supplying additional "EXTRACT" cards, one per listing.

F. General flow charts of the three programs are given in Annex E, while the actual program listings are given in Annex F.

ANNEX A
NEW ENTRY CARD SET PREPARATION

NEW ENTRY CARD SET PREPARATION

1. For each new item to be included in the listing master file, prepare one set of five cards containing all pertinent identifying information. Use columns 1-70 as necessary. Each set may contain from one to four blank cards.
2. Prepare one CODE CARD containing information as to date, origin, type of entry, type of report (if needed), and entry number, date of entry to the file, and subject category or categories. See Annex B, CODE CARD PREPARATION, for details of contents and format. Refer to the last update check listing for the proper entry number.
3. Prepare one ENTRY NUMBER card. Put the entry number as entered on the CODE CARD in columns 1-4.
4. Combine the ENTRY NUMBER card and the five identifying information cards into one 6-card set.

ANNEX A

ANNEX B
CODE CARD PREPARATION

CODE CARD PREPARATION

CARD FORMAT:

DATE				ORI- GIN			ENTRY TYPE				REPORT TYPE									
1	2	3	4	5	6	7	8	9	10	11	12	13	14	15	16	17	18	19	20	21
Y	R	M	O			E	X	T			A	R	T			G	E	N		
						I	N	T			P	R	E			L	I	M		
											R	E	P							

1. DATE - Enter year in columns 1, 2; month in 3, 4. If no month is indicated in the written abstract, use 00 for the month entry on this card, for example:

6505 May 1965
 6712 December 1967
 6900 1969, month unknown

2. ORIGIN - In columns 7, 8, 9 enter EXT for external originator, or enter INT for internal origin.
3. ENTRY TYPE - In columns 12, 13, 14 enter ART for article published in scientific journal or conference proceedings, PRE for presentation by ASRTA personnel at technical meetings, or REP for report.
4. REPORT TYPE - If ENTRY TYPE is REP, then entry must be made in columns 17, 18, 19 of either GEN (general distribution, i.e., Department of Defense) or LIM (limited distribution or internal use only.)

CARD FORMAT (continued):

ENTRY NUMBER				PROCESS DATE										
22	23	24	25	26	27	28	29	30	31	32	33	34	35	36
N	N	N	N							Y	R	M	O	

5. ENTRY NUMBER - Enter a four-digit number coded by type in columns 24, 25, 26, 27. Numbers should be sequential within each section:

1000 series -- INTERNAL ARTICLES
 2000 series -- INTERNAL PRESENTATIONS
 3000 series -- INTERNAL REPORTS, GENERAL DISTRIBUTION
 4000 series -- INTERNAL REPORTS, LIMITED DISTRIBUTION
 5000 series -- EXTERNAL ARTICLES
 6000 series -- EXTERNAL REPORTS, GENERAL DISTRIBUTION
 7000 series -- EXTERNAL REPORTS, LIMITED DISTRIBUTION

CODE CARD PREPARATION (continued)

6. PROCESS DATE - Enter the current year and month as YR and MO in columns 32, 33, 34, 35.

CARD FORMAT (continued):

SUBJECT CATEGORIES -----

1			2			3			4			5											
37	38	39	40	41	42	43	44	45	46	47	48	49	50	51	52	53	54	55	56	57	58	59	60

7. SUBJECT CATEGORIES - Enter three-letter designators, according to the subject categories pertinent to the entry, in columns 38, 39, 40; 43, 44, 45; 48, 49, 50; etc., up to five entries. Possible subjects and their letter designators are:

Atmospheric Modeling	-- MGD
Atmospheric Turbulence	-- TRB
Energy Balance	-- ENB
Soil Physics	-- SPH
Meteorological Effects on CBR Defense	-- CBR
Meteorological Effects on Artillery	-- ART
Meteorological Effects on Air Mobility	-- AMB
Meteorological Effects on Trafficability	-- TRF
Meteorological Effects on Electromagnetic Propagation	-- EMP
Meteorological Effects on Intelligence	-- INT
Meteorological Equipment	-- EQP

"UPDATE" DATA DECK SETUP

The preparation of the data deck for submission with program "UPDATE" must be according to the following rules:

I. Items in the UPDATE data deck must be in the same relative sequence as the items in the working file.

A. Code cards must be updated first.

B. Information deck entries must be updated last.

II. Four options exist with which to update the code card portion of the working file:

A. To correct an existing code card entry requires two cards.

1. First card must have the entry number of the code card to be corrected in columns 1-4 (I4 format).

2. Second card must be the corrected code card.

B. To insert a new code card (or cards) into the existing working file at any one location requires the preparation of one card plus the new code card(s) to be added at that location:

1. The first card must have in columns 1-4 (I4 format) the entry number of the card following which the new card(s) is (are) to be inserted. Columns 5-8 (I4 format) of this card must contain the number of sequential new card entries to be made at this location.

2. The second card (or cards) should be the new code card(s) to be inserted.

C. To correct an existing code card and also insert new cards in sequence immediately after the corrected card requires preparation of one card plus the corrected code card, plus the new code card(s) to be inserted:

1. The first card must contain in columns 1-4 (I4 format) the entry number of the code card to be corrected; columns 5-8 must be left blank; and the number of new entries to follow must be punched in columns 9-12 (I4 format).

2. The second card must be the corrected code card.

3. The third card (or cards) must be the new entry(s).

ANNEX C

D. To delete an existing code card entry requires only one card having the entry number of the card to be deleted in columns 1-4 (I4 format) and 99 punched in columns 7 and 8.

III. The final card used in updating the code card deck must be followed immediately by a termination card having 9999 punched in columns 1-4.

IV. Four options also exist with which to update the information deck portion of the working file: correction of an existing entry, insertion of new entry(s), correction of an entry with insertion of new entry(s) following in immediate sequence, and deletion on an existing entry. The procedures to be followed are identical to those specified in section II, above, with code cards being replaced by 6-card information sets in each instance.

V. The final card updating the information deck section of the working file must also be followed immediately by a termination card with 9999 punched in columns 1-4.

EXTRACT CARD CODING

CARD FORMAT:

KEY				FIRST DATE				LAST DATE				ORIGIN				20	Card Column			
1	2	3	4	5	6	7	8	9	10	11	12	13	14	15	16	17	18	19	20	
9	9			Y	R	M	O			Y	R	M	O			I	N	T		
0	0			9	9	9	9			9	9	9	9			E	X	T		
1	1									N	N	N	N			A	I	L		
2	2																			
3	3																			

The type of listing desired will determine what information is entered on the card:

- KEY** - If all types of entries from both origins are to be listed, enter 99 in columns 1, 2. If particular types only, or specific origin only are to be listed, enter 00. If listing is to be according to a predetermined list of entry numbers, enter 11. If listing is required according to the process (entry) date, enter 22. If listing is required according to subject category, enter 33.
- FIRST DATE, LAST DATE** - If entries from all dates are to be listed, enter 9999 for both dates in columns 5, 6, 7, 8 and 11, 12, 13, 14. If entries from a specific time period are to be listed, enter YR and MO (year and month) of beginning of period in 5, 6, 7, 8 and YRMO for end of period in 11, 12, 13, 14. For example:
 for calendar year 1968: enter 6801 and 6812
 for fiscal year 1968: enter 6707 and 6806.

 If KEY was entered as 11, enter 9999 for FIRST DATE and a four-digit integer number (NNNN) for LAST DATE, where NNNN will equal the number of entries in the predetermined list of entry numbers.
- ORIGIN** - If KEY = 99, 11, or 22 no entry is required. If KEY = 00 or 33 enter INT (internal origin), EXT (external), or ALL (both internal and external origins) as required in columns 17, 18, and 19.

CARD FORMAT (continued):

ENTRY TYPE				REPORT TYPE				30	31	32	33	Card Column	
21	22	23	24	25	26	27	28	29	30	31	32	33	
A	R	T		G	E	N							
P	R	E		L	I	M							
R	E	P		A	L	L							
A	L	L											
Subject													

ANNEX D

EXTRACT CARD CODING (continued)

4. ENTRY TYPE - If KEY = 99, 11, or 22 no entry is needed. If KEY = 00, enter ART (article), PRE (presentation), REP (report), or ALL (all types) as required in columns 22, 23, 24. If KEY = 33, enter subject category desired:

MOD	AMB
TRB	TRF
ENB	EMP
SPH	INT
CBR	EQP
ART	

5. REPORT TYPE - If TYPE = REP or ALL, enter GEN (general distribution reports only), LIM (limited distribution or internal use reports only), or ALL (both types of report) in columns 27, 28, 29.

PROGRAM RELIST

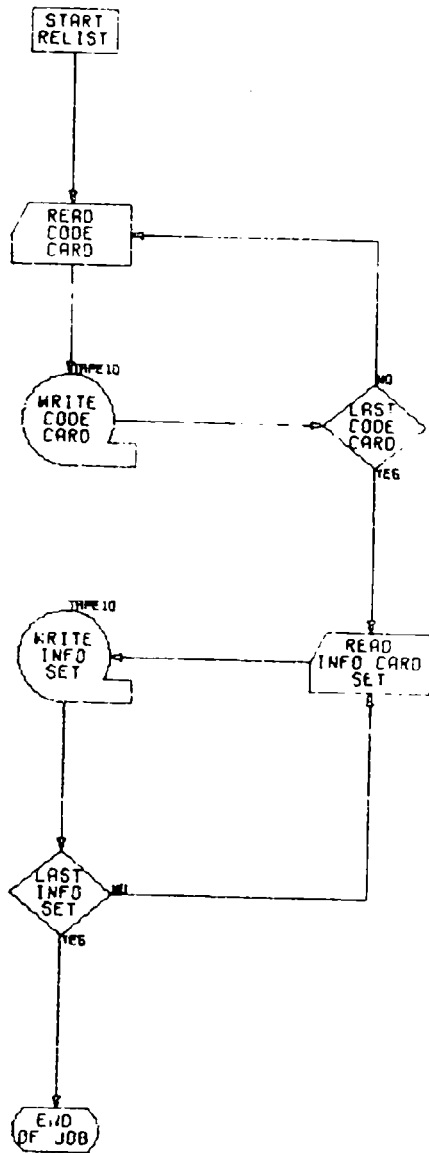

PROGRAM UPDATE

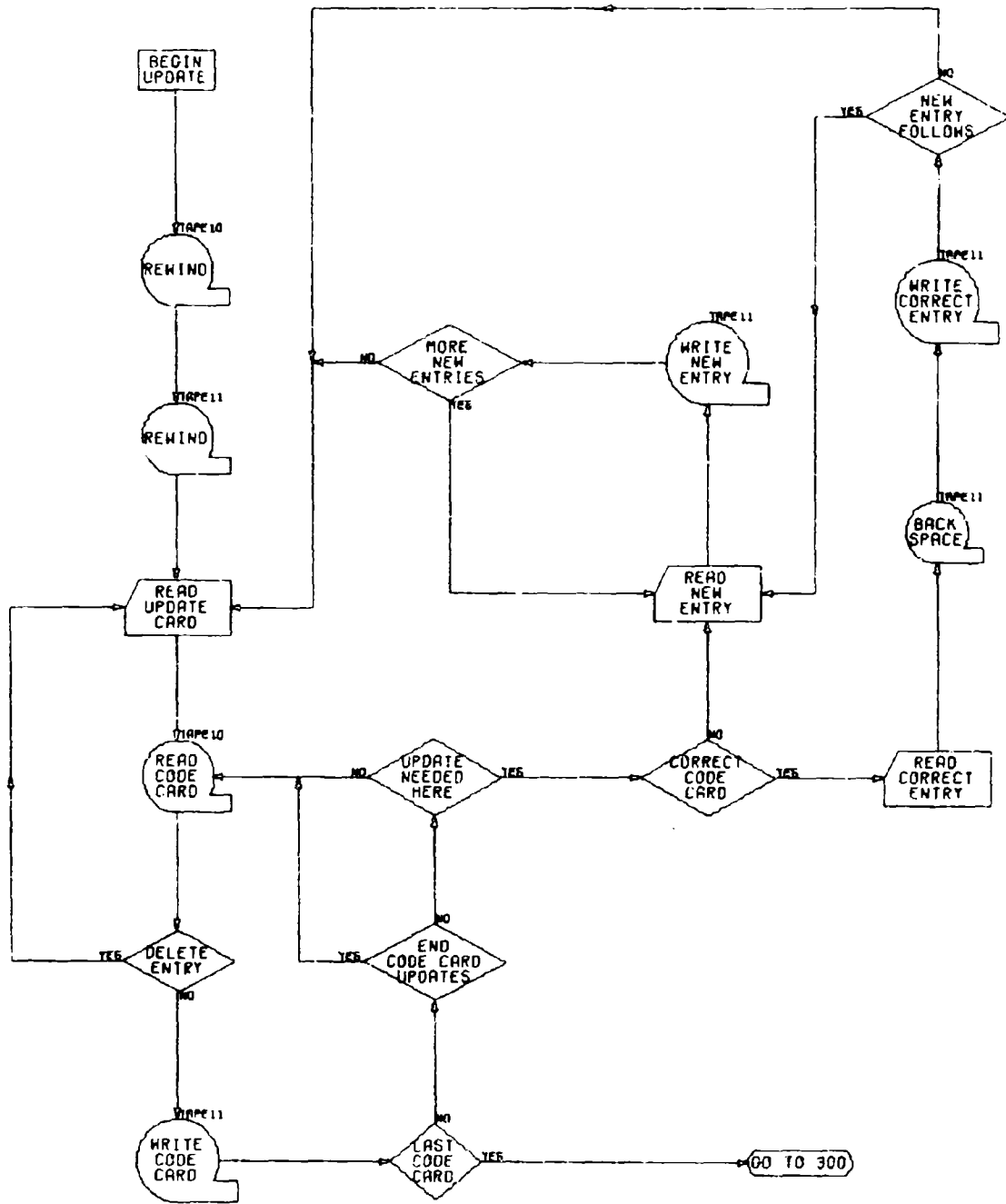

PROGRAM UPDATE (CONTINUED)

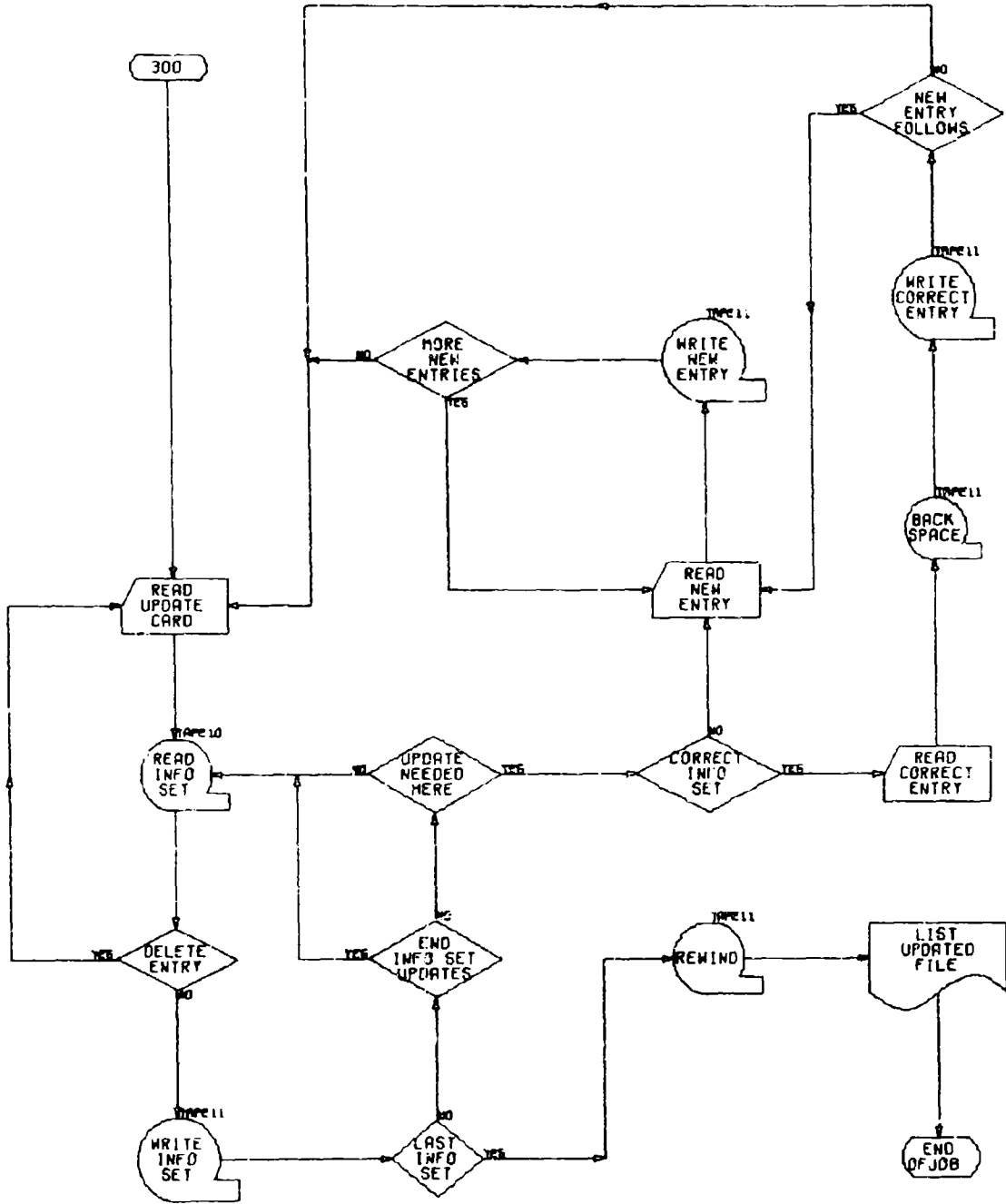

PROGRAM SELIST

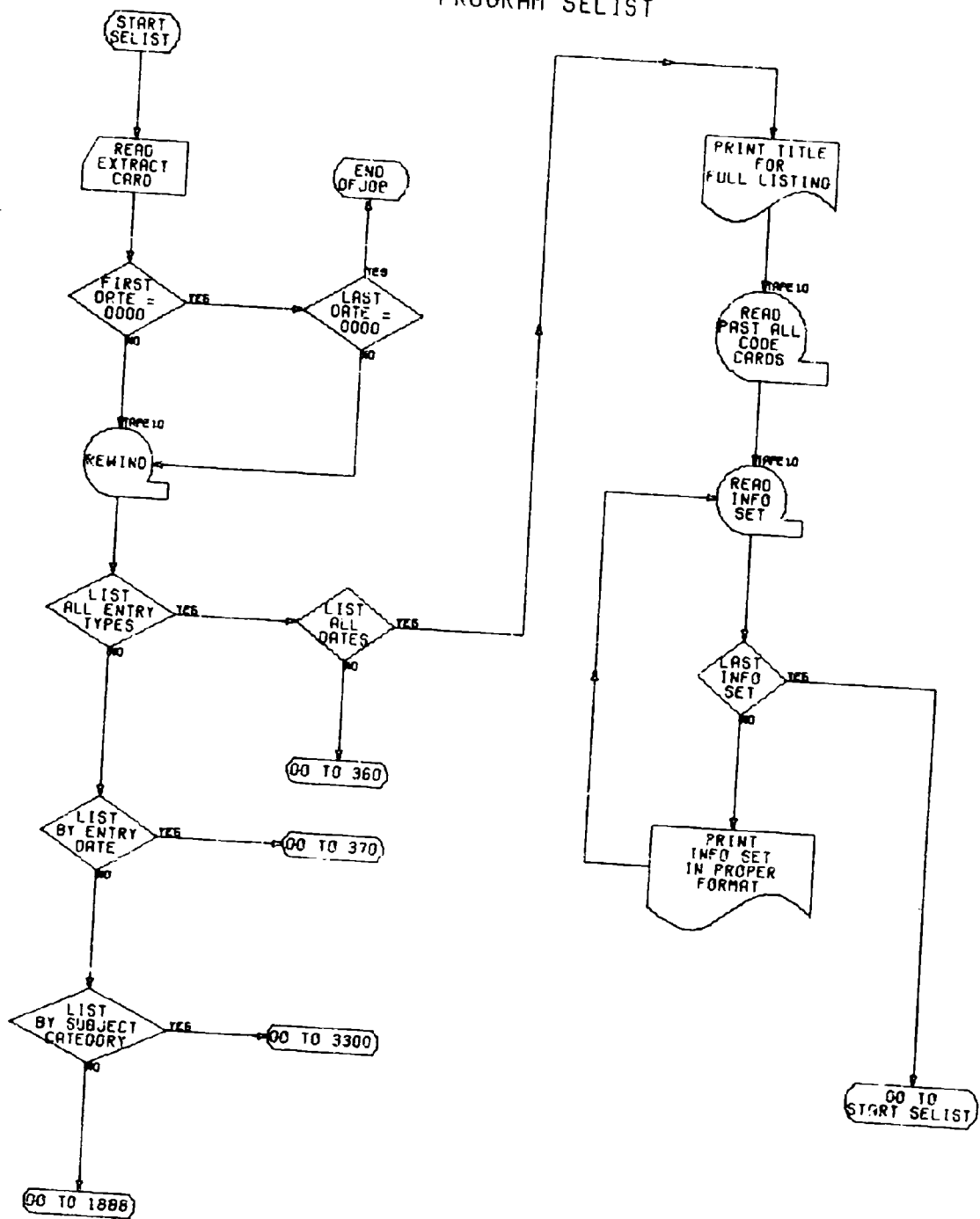

ANNEX E

PROGRAM SELIST (CONTINUED)

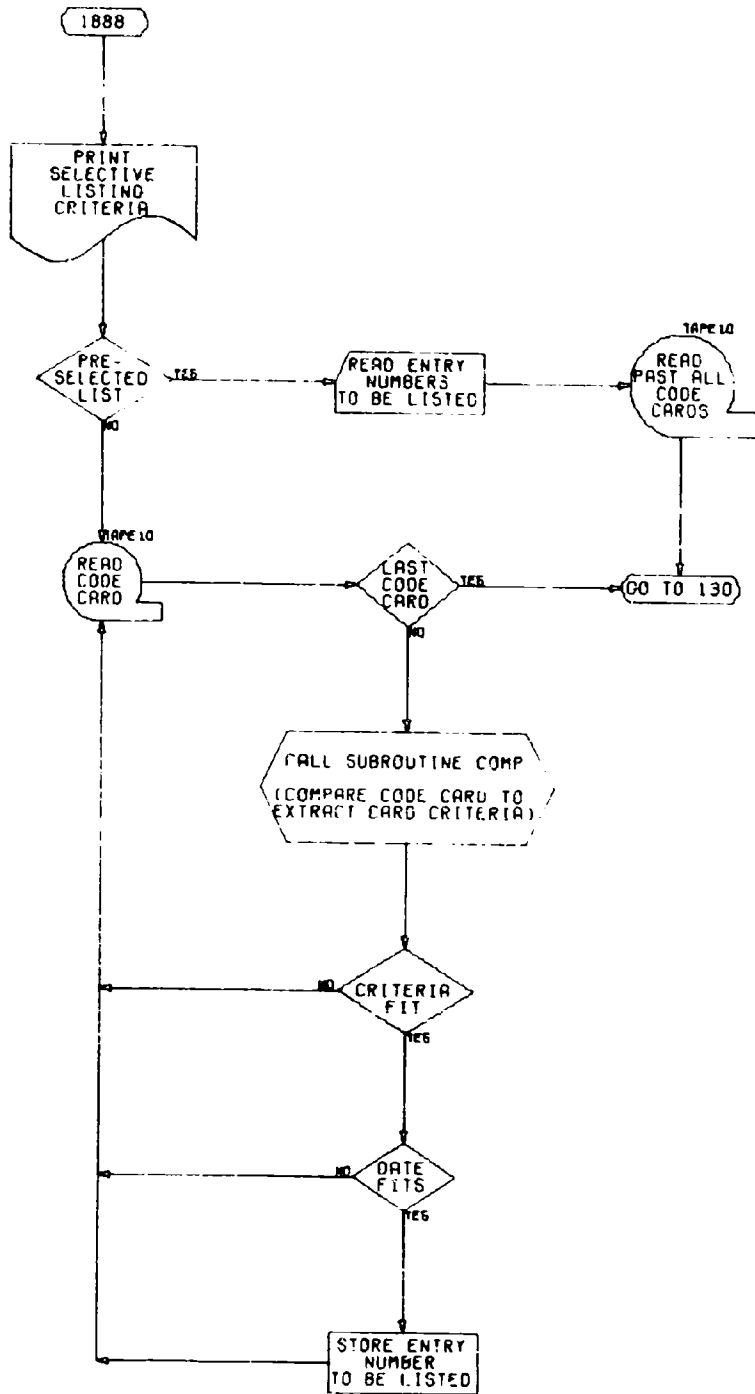

PROGRAM SELIST (CONTINUED)

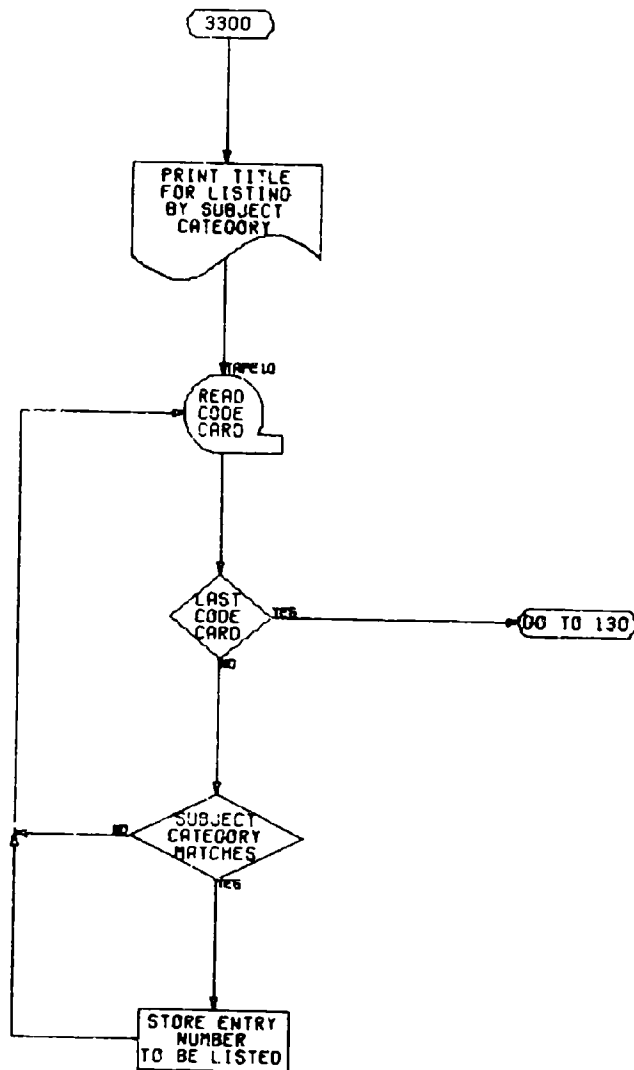

PROGRAM SELIST (CONTINUED)

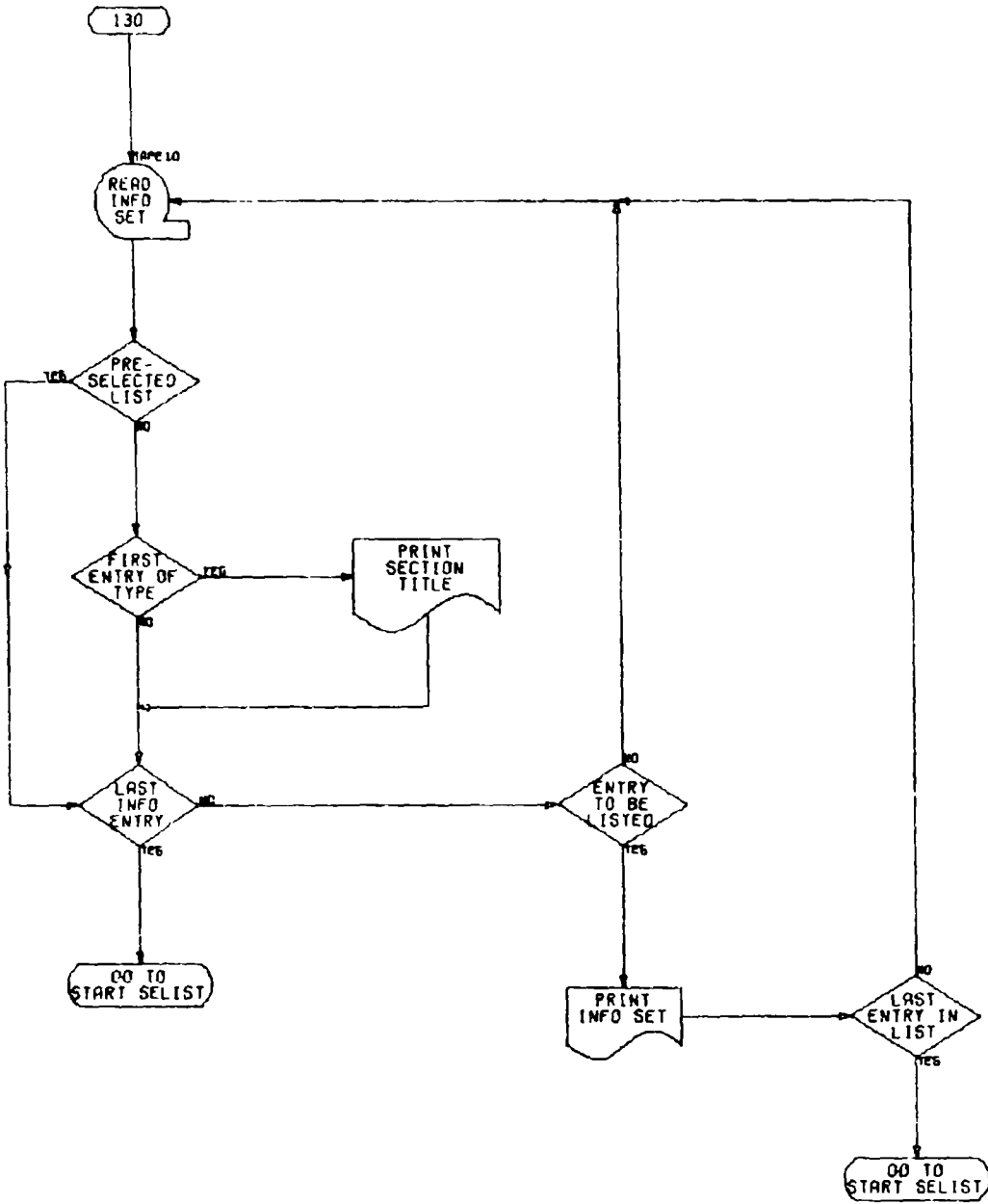

PROGRAM SELIST (CONTINUED)

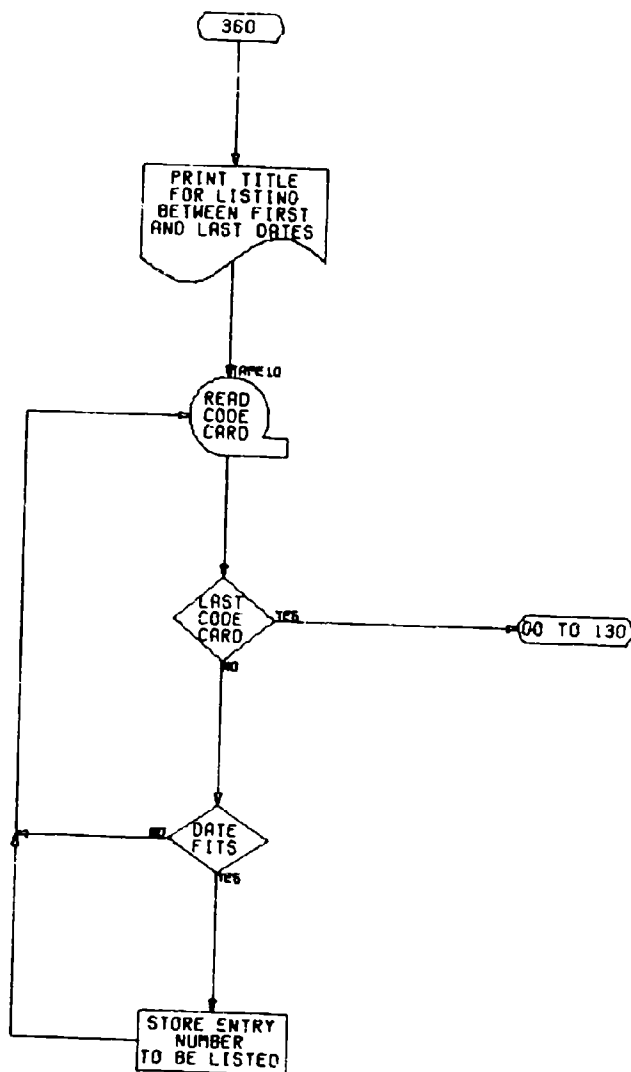

PROGRAM SELIST (CONTINUED)

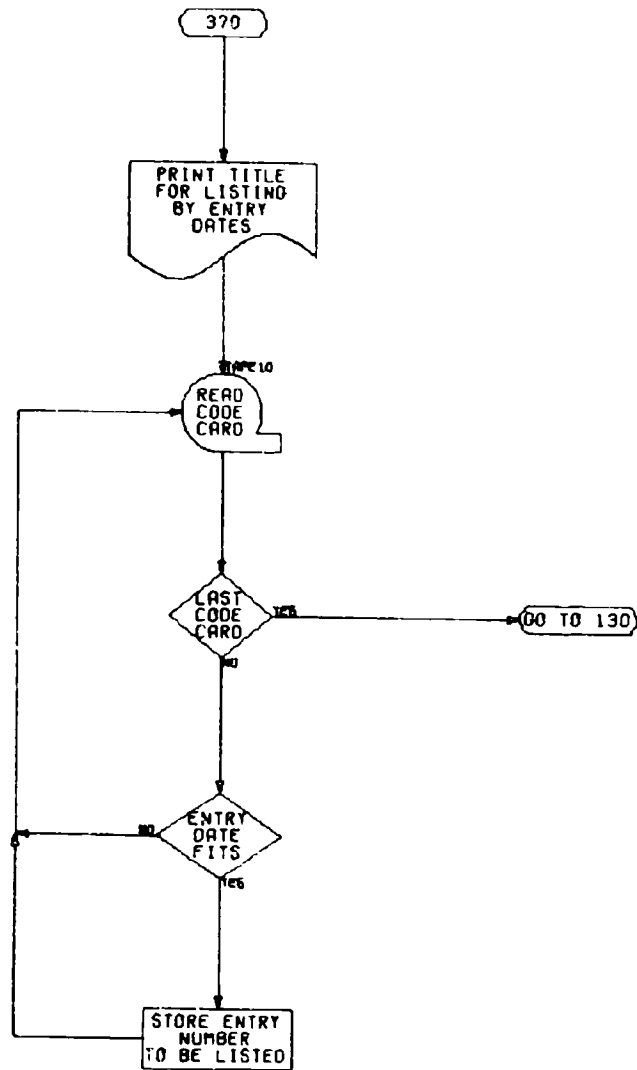

ANNEX F
PROGRAM LISTINGS

```

PROGRAM RELIST(INPUT,TAPES=INPUT,TAPE10)
C-----PROGRAM TO WRITE WORKING FILE TAPE TO BE USED WITH
C REPORT LISTING PROGRAMS UPDATE AND SELIST
DIMENSION LIST(100)
C-----BEGIN BY READING AND WRITING CODE CARDS
100 READ(5,1) IDATE,IORG,ITYP,IREF,NLIST,IPROC,IS1,IS2,IS3,IS4,IS5
1 FORMAT(I4,3(2X,I3),2(2X,I4),5(2X,I3))
WRITE(10,1) IDATE,IORG,ITYP,IREF,NLIST,IPROC,IS1,IS2,IS3,IS4,IS5
IF (IDATE.EQ.9999) GO TO 200
GO TO 100
C-----CONTINUE BY READING AND WRITING INFO DECK
200 READ(5,2) NTRY.(LIST(I),I=1,99)
2 FORMAT(I4,/, (I4A5))
WRITE(10,2) NTRY.(LIST(I),I=1,99)
IF (NTRY.NE.9999) GO TO 200
END FILE 10
STOP
END

```

NOT REPRODUCIBLE

PROGRAM UPDATE(INPUT,OUTPUT,TAPE10,TAPE11,TAPE5=INPUT,TAPE6=OUTPUT
*)

```
C-----REPORT LISTED UPDATE TAPE PROGRAM
      DIMENSION LIST(80),NULIST(80),NEW(200)
C       MOUNT CURRENT WORKING FILE TAPE ON TAPE10
      REWIND 10
C       MOUNT BLANK TAPE ON TAPE11 FOR CREATION OF NEW WORKING FILE
      REWIND 11
      DO J I=1,200
        NEW(J)=9999
      JJ=0
500 READ(5,10) NEXT,MULTI,MORE
      IF FORMAT (6I4)
400 READ(10,20) ID,IO,IT,IR,NL,IP,IS1,IS2,IS3,IS4,IS5
      20 FORMAT (I4,3(2X,A3),2(4X,I4),5(2XA3))
C       CHECK TO SEE IF ENTRY IS TO BE ELIMINATED
      IF (NL.EQ.NEXT.AND.MULTI.EQ.99) GO TO 500
      WRITE(11,20) ID,IO,IT,IR,NL,IP,IS1,IS2,IS3,IS4,IS5
      IF (ID.EQ.9999) GO TO 300
      IF (NEXT.EQ.9999) GO TO 400
      IF (NL.EQ.NEXT) GO TO 200
      GO TO 400
200 IF (MULTI.EQ.0) GO TO 1200
250 DO 1300 I=1,MULTI
      READ(5,20) IDATE,IORG,ITYP,IREP,NLIST,IPROC,IS1,IS2,IS3,IS4,IS5
      IF (IPROC.EQ.0) GO TO 1300
      JJ=JJ+1
      NEW(JJ)=IPROC
1300 WRITE(11,20) IDATE,IORG,ITYP,IREP,NLIST,IPROC,IS1,IS2,IS3,IS4,IS5
      GO TO 500
1200 READ(5,20) IDATE,IORG,ITYP,IREP,NLIST,IPROC,IS1,IS2,IS3,IS4,IS5
      BACKSPACE 11
      WRITE(11,20) IDATE,IORG,ITYP,IREP,NLIST,IPROC,IS1,IS2,IS3,IS4,IS5
      MULTI=MORE
      IF (MULTI.NE.0) GO TO 250
      GO TO 500
300 READ(5,10) NEXT,MULTI,MORE
700 READ (10,30) NTRY,(LIST(I),I=1,80)
C       CHECK TO SEE IF ENTRY IS TO BE ELIMINATED
      IF (NTRY.EQ.NEXT.AND.MULTI.EQ.99) GO TO 300
      WRITE (11,30) NTRY,(LIST(I),I=1,80)
      IF (NTRY.EQ.9999) GO TO 1350
      IF (NEXT.EQ.9999) GO TO 700
      IF (NTRY.EQ.NEXT) GO TO 600
      GO TO 700
600 IF (MULTI.EQ.0) GO TO 1600
650 DO 850 K=1,MULTI
      READ (5,30) NT,(NULIST(I),I=1,80)
      30 FORMAT (I4,/, (16A5))
      850 WRITE (11,30) NT,(NULIST(I),I=1,80)
      GO TO 300
1600 DO 800 K=1,6
      800 BACKSPACE 11
      READ (5,30) NT,(NULIST(I),I=1,80)
1850 WRITE (11,30) NT,(NULIST(I),I=1,80)
      MULTI=MORE
      IF (MULTI.NE.0) GO TO 650
```



```

      GO TO 300
1350 NEW(JJ) = 11
C-----LIST ALL-----
      350 WRITE (6,351)
      351 FORMAT (66H1 THE FOLLOWING IS A COMPLETE LISTING OF ALL ITEMS FOR
            $ ALL DATES
            )
            JJ=1
      50 READ (11,20) 1DATE,1ORG,1TYP,1REP,NLIST,1PROC,1S1,1S2,1S3,1S4,1S5
            IF (1PROC.EQ.NEW(JJ)) GO TO 225
            *WRITE (6,21) 1DATE,1ORG,1TYP,1REP,NLIST,1PROC,1S1,1S2,1S3,1S4,1S5
      21 FORMAT (1X,14,3(2X,A3),2(4X,I4),5(2X,A3))
            GO TO 226
      225 NEW(JJ)=NLIST
            JJ=JJ+1
            *WRITE (6,22) 1DATE,1ORG,1TYP,1REP,NLIST,1PROC,1S1,1S2,1S3,1S4,1S5
      22 FORMAT (1X,14,3(2X,A3),2(4X,I4),5(2X,A3),10X,3HNEW)
      226 IF (1DATE.EQ.9999) GO TO 2200
            GO TO 50
2200 NTRYX=1000
            JJ=1
            GO TO 100
      99 NTRYX=NTRYX+1000
            *WRITE (6,98) (LIST(I),I=1,80)
      98 FORMAT (1M1,5(10X,16A5//))
      100 AN=1.0
      1100 READ (11,30) NTRY, (LIST(I),I=1,80)
            IF (NTRY.EQ.9999) GO TO 777
            IF (NTRY.EQ.NTRYX) GO TO 99
            IF (NTRY.EQ.NEW(JJ)) GO TO 325
      110 *WRITE (6,15) XN, (LIST(K),K=1,16), NTRY, (LIST(K),K=17,80)
      15 FORMAT (/F4.0,1X,16A5,20X,I4,/(5X,16A5))
      326 XN=XN+1.0
            GO TO 1100
      325 JJ=JJ+1
            *WRITE (6,16) XN, (LIST(K),K=1,16), NTRY, (LIST(K),K=17,80)
      16 FORMAT (/F4.0,1X,16A5,20X,I4,5X,3HNEW,/(5X,16A5))
            GO TO 326
      777 CONTINUE
            STOP
            END

```

NOT REPRODUCIBLE

```

SUBROUTINE COMP1 (X1,H1,X2,H2,IX3,IX4,IX5,IA6,IX7,H3,AM)
  INTEGER H1,H2,H3
  IF (X1.EQ.H1) GO TO 33
  IF ((IX2.EQ.H2.OR. IX2.EQ. IX3).AND. (IX1.EQ.H2.OR. (X1.EQ. IX5).AND. (IX
10.EQ.H2.OR. IX6.EQ. IX7.OR. IA7.EQ. H3))) RETURN
  H=2
  RETURN
33 IF ((IX2.EQ.H2.OR. IX2.EQ. IX3).AND. (IX6.EQ.H1)).AND. ((IX6.EQ.H2).OR
4.(IX6.EQ. IX7))) RETURN
  H=2
  RETURN
END

```

```

PROGRAM SELIST(INPUT,OUTPUT,TAPE5=INPUT,TAPE6=OUTPUT,TAPE10)
C-----ABSTRACT CARD LISTING PROGRAM
C
  INTEGER M1,M2,LIST(80),NULIST(1500),PRDATE,SUBJ1,SUBJ2,SUBJ3,SUBJ4
  *SUBJ5
C-----INPUT EXTRACT CARD-----
  2222 HEAD(5,500) TORALL,IRDATE,LADATE,IORG,IYPE,IFREP
  500 FORMAT (I2,2I6,3(2X,A3))
  IF(IRDATE.EQ.0000.AND.LADATE.EQ.0000) GO TO 666
  REWIND 10
  IF (IORALL.EQ.99.AND.IRDATE.EQ.9999) GO TO 350
  IF (IORALL.EQ.99) GO TO 360
  IF (IORALL.EQ.22) GO TO 370
  IF (IORALL.EQ.33) GO TO 3300
  GO TO 1880
C-----LIST ALL-----
  350 WRITE (6,351)
  351 FORMAT (66H1 THE FOLLOWING IS A COMPLETE LISTING OF ALL ITEMS FOR
  & ALL DATES )
  50 HEAD (10,20) IDATE
  20 FORMAT (I4)
  IF (IDATE.EQ.9999) GO TO 200
  GO TO 50
  200 NTRYX=1000
  GO TO 100
  99 NTRYX=NTRYX+1000
  WRITE (6,98) (LIST(I),I=1,80)
  98 FORMAT (I1,5(10X,16A5//) )
  100 AN=1.0
  1100 HEAD (10,10) NTRY,(LIST(I),I=1,80)
  10 FORMAT (I4,/,16A5)
  IF (NTRY.EQ.9999) GO TO 2222
  IF (NTRY.EQ.NTRYX) GO TO 99
  110 WRITE (6,15) XN,(LIST(K),K=1,16),NTRY,(LIST(K),K=17,80)
  15 FORMAT (/F4,0,1X,16A5,20X,I4,/(5X,16A5))
  AN=XN+1.0
  IF (AMOU(XN,10.0).EQ.0.0) WRITE (6,1234)
  GO TO 1100
C-----LIST BY DATE-----
  360 WRITE (6,361) IRDATE,LADATE
  361 FORMAT (49H1 THE FOLLOWING IS A LISTING OF ALL ITEMS /12H DATE
  & FROM,I6,4H TO,I6)
  60 DO 75 I=1,1500
  61 HEAD (10,120) IDATE,NLIST
  120 FORMAT (I4,19X,I4)
  IF (IDATE.EQ.9999) GO TO 130
  IF (IDATE.GE.IRDATE.AND.IDATE.LE.LADATE) GO TO 74
  IF ((IDATE.EQ.((IRDATE/100)*100)).OR.(IDATE.EQ.((LADATE/100)*100)))
  & GO TO 74
  GO TO 61
  74 NULIST(I) = NLIST
  75 CONTINUE
  130 NTRYX=1000
  I=I-1
  1130 AN=1.0
  DO 85 J=1,I
  IF (AMOU(XN-1.0,10.0).EQ.0.0) WRITE (6,1234)

```

```

1234 FORMAT (1M1,///)
95 HEAD (10,10) NTRY,(LIST(K),K=1,80)
   IF (IORALL.EQ.11) GO TO 2255
   IF (NTRY.EQ.NTRYX) GO TO 1199
2255 IF (NTRY.EQ.9999) GO TO 2222
195 IF (NTRY.EQ.NULIST(J)) GO TO 88
   GO TO 95
1199 NTRYX=NTRYX+1000
   WRITE (6,98) (LIST(K),K=1,80)
   GO TO 195
88 WRITE (6,15) XN,(LIST(K),K=1,16),NTRY,(LIST(K),K=17,80)
85 XN=XN+1.0
   GO TO 2222
C-----SELECTIVE-LIST-----
1888 WRITE (6,1888) IRDATE,LADATE,IORG,ITYPE,IFREP
1889 FORMAT (57M) THIS SELECTIVE LISTING WAS PREPARED ACCORDING TO THE
   S /33M. FOLLOWING EXTRACT INFORMATION /21M INCLUSIVE DATES ARE
   $,I6,4M TO,I6/16M ORIGINATOR IS ,A3/19M TYPE OF ENTRY IS ,A3/
   $17M REPORT TYPE IS ,A3)
   IF (IORALL.EQ.11) GO TO 1111
888 DO 55 I=1,1500
57 HEAD (10,56) IDATE,IUGX,ITYPX,IREPX,NLIST
56 FORMAT (I4,3(2X,A3),4X,I4)
   IF (IDATE.EQ.9999) GO TO 130
   MM=1
   CALL COMP (ITYPE,3HREP,IORG,3HALL,IORGX,ITYPE,ITYPX,IFREP,IREPX,
   13M ,MM)
   GO TO (400,57),MM
400 CONTINUE
   IF ((IRDATE.FQ.9999).OR.(IDATE.GE.IRDATE.AND.IDATE.LE.LADATE)) GO
   2 TO 58
   IF ((IDATE.EQ.((IRDATE/100)*100)).OR.(IDATE.EQ.((LADATE/100)*100)))
   $GO TO 58
   GO TO 57
58 NULIST(I)=NLIST
55 CONTINUE
   GO TO 130
1111 HEAD (5,1112) (NULIST(I),I=1,LADATE)
1112 FORMAT (20I4)
   I=LADATE
1113 HEAD (10,20) IDATE
   IF (IDATE.EQ.9999) GO TO 1130
   GO TO 1113
370 WRITE(6,372) IRDATE, LADATE
372 FORMAT(*1THE FOLLOWING ENTRIES WERE MADE BETWEEN*,I6,* AND*,I6)
   DO 375 I=1,1500
371 HEAD(10,373) IDATE,NLIST,PKDATE
373 FORMAT(I4,19X,I4,4X,I4)
   IF (IDATE.EQ.9999) GO TO 130
   IF (PKDATE.GE.IRDATE.AND.PKDATE.LE.LADATE) GO TO 374
   GO TO 371
374 NULIST(I)=NLIST
375 CONTINUE
   GO TO 130
3300 WRITE (6,3301) IRDATE, LADATE, IORG, ITYPE
3301 FORMAT (*1 THIS SELECTIVE LISTING WAS PREPARED ACCORDING TO THE
   1*/* FOLLOWING EXTRACT INFORMATION*//* INCLUSIVE DATES ARE*
   2,I6,* TO*,I6/* ORIGINATOR IS *,A3/* SUBJECT CATEGORY IS *,A3)

```

```

3320 00 3310 1=1,1500
3319 00 05 3318) IDATE, IORGX, ITYPX, IREFX, M, IST, IPENC, SUBJ1, SUBJ2, SUBJ
    13, SUBJ4, SUBJ5
3318 00 00 01 (14, 1(2X, 03) 02(4X14) 03(2X03))
    IF (IDATE.EQ.9999) GO TO 130
    IF ((ITYPE.EQ.SUBJ1.OR.ITYPE.EQ.SUBJ2.OR.ITYPE.EQ.SUBJ3.OR.ITYPE.
    EQ.SUBJ4.OR.ITYPE.EQ.SUBJ5).AND.((IORGX.EQ.IORG).OR.(IORG.EQ.SMALL
    2)).AND.((IDATE.EQ.9999).OR.(IDATE.GE.IDUATE.AND.IDATE.LE.LADATE)))
    GO TO 3315
    GO TO 3319
3315 00 01 LIST(1)=MLIST
3316 00 00 CONTINUE
    GO TO 130
006 00 00 STOP
    END

```