

19 March 1971

Materiel Test Procedure 7-2-087  
General Equipment Test Activity

U.S. ARMY TEST AND EVALUATION COMMAND  
COMMODITY ENGINEERING TEST PROCEDURE

CLOTHING (AVIATION)

1. OBJECTIVE\*

This document provides test methodology and testing techniques necessary to determine the technical performance and safety characteristics of aviation clothing, and associated accessories as described in Materiel Needs (MN) and to determine the item's suitability for service tests.

2. BACKGROUND

a. Army aviation operations are undertaken during daylight hours, at night, and in the environments of the desert, jungle, arctic, or intermediate climatic areas.

b. The proper selection of garments which comfortably protect the wearer from hostile environments implied by the task and operational theater, demands a profound understanding of the operational requirement, the human body, and Army aviation mission structures. For the purpose of this document, the following list summarizes the Army aviation clothing requirement base.

- 1) Clothing which provides basic bodily needs with the interior of aircraft and helicopters under normal conditions of altitude, temperature, and mission.
- 2) Clothing which protects the wearer from hazards of conditions resulting from inflight emergencies including fire, rupture of the cabin, or extreme cold due to unexpected exposure at high altitude.
- 3) Clothing which protects the wearer during descent by parachute from a burning or otherwise disabled aircraft or during conditions arising from forced landings on land or at sea.
- 4) Clothing which protects and contributes to the probability of survival following successful bail-out or forced landing in hostile terrain under possible conditions of the desert, arctic, or jungle.

c. The four basic aviation clothing requirements listed and discussed above can be matched to the following major Army Aviation missions:

\*This MTP is intended to be used as a basic guide in preparing actual test plans for the subject material. Specific criteria and test procedures must be determined only after careful appraisal of pertinent MN, and any other applicable documents.

AD 723030

DDC  
RECEIVED  
MAY 12 1971  
RECEIVED

**BLANK PAGE**

MTP 7-2-087  
19 March 1971

- 1) Aerial observation and surveillance operations.
- 2) Airlift of personnel and materiel.
- 3) Aerial fire support.
- 4) Aeromedical evacuation.
- 5) Air crash rescue.
- 6) Aviation support of internal defense and guerrilla warfare operations.

d. The foregoing discussion pertains essentially to conventional concepts of aerial warfare and tactical aviation support. There are other requirements for specialized flying garments as a result of unique mission characteristics. Of particular importance is the Army Aviation mission referred to as "chemical, biological, and radiological (CBR) operations." The crew of aircraft involved in this mission are in danger of contamination when transporting chemical or biological agents and munitions should a leak occur. Also, a potential hazard for the crew exists whenever aircraft are used to disseminate chemical agents and munitions. To avert potential danger imposed by this mission, special protective clothing is necessary and protective masks are essential (see MTP 7-2-086).

e. Requirements also exist for aviation clothing which may be donned quickly in the large, long range Army aircraft forced to ditch at sea. This requirement implies the need for anti-exposure garments which protect the wearer from exposure while swimming in cold water and from the effects of wind, spray, and rain when marooned in a life raft.

f. In general, aviation clothing may be grouped for the purpose of identification and testing into three categories as follows:

- 1) Flying Coveralls: These garments are of a one-piece construction and made of fabrics or materials of various weights to suit personal comfort requirements, i.e., summer, winter, etc. At present, coveralls possessing the following uses and characteristics are available:
  - a) Lightweight, lined.
  - b) Anti-exposure.
  - c) High altitude.
  - d) Anti-exposure, quick donning.
  - e) Summer, fire resistant.
  - f. CBR protective.
- 2) Flying Suits: These garments consists of two or more pieces, including, as a minimum, a jacket and trousers. Flying suits are presently available for the majority of uses cited above. These garments can also serve as the insulating liner to be worn under anti-exposure coveralls.
- 3) Aviation Clothing Accessories: Included with this group are flight jackets, vests, gloves, scarfs, and other small items of personal clothing, i.e., socks, undergarments, etc.

3.           REQUIRED EQUIPMENT
- 3.1           GENERAL EQUIPMENT
- a. Measuring tape, ruler, and caliper.
  - b. Weighing scale.
  - c. Photographic equipment.
  - d. Stop watch.
  - e. POL substances, JP-4, gasoline, etc.
  - f. Soap.
- 3.2           INSTRUMENTATION
- a. Direct reading balance, accuracy  $\pm$  0.05 ounce.
  - b. Color comparison standards.
  - c. Water-repellency tester (hydrostatic head method).
  - d. Instrumentation required for materials testing (See 6.1.4 Physical Characteristics).
  - e. Radiant and convective heat apparatus (fuel burner)
- 3.3           FACILITIES
- a. Rain test chamber or area.
  - b. Dry cleaning facility.
  - c. Laundry.
  - d. High temperature chamber.
  - e. Fungus test facility.
  - f. Radiant energy testing facility.
  - g. Slide fastener endurance test stand.
  - h. Walk-in cold chamber
- 3.4           AVIATION EQUIPMENT
- a. Footwear.
  - b. Headwear, helmets, etc.
  - c. Handwear.
  - d. Aircraft seats or simulation thereof.
  - e. Parachute(s).
  - f. Oxygen supply system components, e.g., hoses, masks, suspension devices, etc.
4.           REFERENCES
- A. USATECOM Regulation 385-6 Safety: Verification of Safety of Materiel During Testing.
  - B. USATECOM Regulation 70-23 Research and Development: Equipment Performance Reports (EPRs).
  - C. USATECOM Regulation 700-1 Quality Assurance: Value Engineering.
  - D. USAGETA Document Human Factors Evaluation Data for General Equipment (HEDGE).

MTP 7-2-087  
19 March 1971

- E. FED-STD-601 Rubber; Sampling and Testing.
- F. FED-STD-751 Stitches, Seams, and Stitchings.
- G. MIL-STD-129 Marking for Shipment and Storage.
- H. MIL-STD-130 Identification Marking of US Military Property.
- I. MIL-STD-282 Filter Units, Protective Clothing, Gas-Mask Components and Related Products: Performance Test Methods.
- J. MIL-STD-810 Environmental Test Methods.
- K. FED-SPEC-CCC-T-191 Textile Test Methods.
- L. FED-SPEC-DDD-L-20 Label; for Clothing, Equipment, and Tentage.
- M. MIL-E-5272 Environmental Testing, Aeronautical and Associated Equipment, General Specification for.
- N. MTP 7-2-506 Airdrop Systems Safety.
- O. MTP 7-2-509 Airdrop Capability of Materiel (General).
- P. MTP 10-2-500 Physical Characteristics.
- Q. MTP 10-2-501 Operator Training and Familiarization.
- R. MTP 10-2-503 Surface Transportability (General Supplies and Equipment).
- S. MTP 10-2-506 Human Factors Evaluation.
- T. TM700-8400-1 Fitting of Uniform.
- U. AATCC Test Method No. 76-1964.

5. SCOPE

5.1 SUMMARY

This procedure describes the preparation for and methods of evaluating the technical characteristics of aviation clothing and their suitability for service testing. The required tests are summarized as follows:

a. Preparation for Test - A determination of the condition and physical characteristics of the test item upon arrival. Also, to ensure that the test item is complete and functionally operational, and to provide operator training and familiarization procedures.

b. Sizing and Fitting Test - A determination of the sizing and fitting characteristics of the test item as related to wear with standard task-oriented clothing and equipment.

c. Donning and Doffing - An evaluation of the design of the test item for the ease and safety of putting on, and removing from the body, in conjunction with standard task-oriented clothing and equipment.

d. Compatibility with Associated Aviation Clothing and Personal Equipment - A determination of specific interface characteristics between the test item and existing, or under development, aviation clothing and personal equipment.

e. Water/POL - Repellency and Cleaning Tests - A series of tests to determine test item characteristics when laundered or dry cleaned and test item susceptibility to POL wetting.

f. Anti-Exposure and CBR Protective Clothing Tests - Determinations for elastomer-type test item characteristics such as leakage and high temperature tackiness.

g. Resistance to Generation of Static Electricity - Determinations of those test item characteristics which support the generation of static electricity and pose a potential hazard or wearer discomfort.

h. Endurance Tests - Determination of durability characteristics of test item(s) when subjected to extended laundering and dry cleanings. Also, determination of durability of test item slide fastener types.

i. Fungus Resistance Test - Determination of test item ability to resist damage from fungus growth(s).

j. Sunshine Test - Determination of test item ability to resist damage or deterioration from exposure to radiant energy at an accelerated rate.

k. Maintenance Evaluation - An evaluation to determine and appraise the maintenance characteristics and requirements of the test item, a verification and appraisal of its malfunctions, an evaluation of the test item's associated publications and other common and special support elements (maintenance test package), an appraisal of the test item's design for maintainability (AMCP 706-134: accessibility, ease of maintenance, standardization, and interchangeability), an evaluation of component and system durability and achieved availability, and the calculation of indicators which express the effects of the preceding aspects.

l. Reliability - An evaluation to determine the probability that the test item will perform its intended function for a specified interval under stated conditions.

m. Transportability - An evaluation to determine test item ability to withstand the forces it will experience during normal handling and transportation.

n. Safety - An evaluation to determine the safety characteristics and possible hazards of the test item.

o. Human Factors Evaluation - An evaluation to determine the adequacy of the design and performance characteristics of the test item and associated equipment in terms of conformance to accepted human factors engineering design criteria.

MTP 7-2-087  
19 March 1971

p. Value Analysis - An evaluation directed at analyzing the primary function and features of the test item for the purpose of reducing the cost of the test item without compromising performance and safety characteristics.

q. Quality Assurance - A review for the purpose of determining and evaluating defects in material and workmanship.

5.2. LIMITATIONS

None.

6. PROCEDURES

6.1 PREPARATION FOR TEST

6.1.1 Initial Inspection

Upon receipt of the test item at the test site, perform applicable procedures of MTP 10-2-500 and the following:

a. Visually inspect the packaged test item. Record the following:

- 1) Evidence of damage incurred during transport or storage.
- 2) Exterior identification markings not in accordance with MIL-STD-129 or other governing documents.

b. Unpack and visually inspect the test item. Record evidence of the following:

- 1) Interior marking(s) of shipment not in accordance with MIL-STD-129 or other governing documents.
- 2) Evidence of any hole, scissors or knife cut, tear, mend or weakening defect such as smash, multiple float, loose slub, needle chews, etc., that may develop into a hole.
- 3) Evidence of stiffened, hardened, or seared by heat cloth/material caused by thermo-activated shade and size marking tickets attachment.
- 4) Evidence of stitching that is not caught in other seams or stitching.
- 5) Evidence of twisted, puckered, or pleated seams.

6.1.2 Inventory Check

a. Conduct an inventory against the Basic Issue Item List (BIIL). Record evidence of the following:

- 1) Missing maintenance literature or draft technical manuals.
- 2) Shortages in accessories.

b. Submit an Equipment Performance Report (EPR) for each noted shortage or discrepancy.

#### 6.1.3 Inspection and Preliminary Operation

a. Perform preliminary fitting, sizing, and inspections in accordance with the draft technical manual.

b. Ensure that the test item is clean and is not spotted, stained, or otherwise soiled. Also, check metal fastenings for evidence of corrosive effects.

c. Examine test item label(s) or patches for conformance with MIL-STD-130, FED-SPEC-DDD-L-20, or other governing documents. Record evidence of the following:

- 1) Size information incomplete, incorrect, or illegible.
- 2) Misplaced label or missing altogether.
- 3) Other defects or incomplete information furnished.
- 4) Special cleaning requirements not clearly marked.

d. Inspect each test item and record evidence of defects in the following areas:

- 1) Slide fasteners.
- 2) Fastener tape.
- 3) Eyelets and washers.
- 4) Seams.
- 5) Stitching.
- 6) Front openings, if applicable.
- 7) Pockets: breasts, thigh, shin, knife, etc.
- 8) Hip openings.
- 9) Sleeves.
- 10) Waistband or waistband tunnel.
- 11) Hanger.

#### 6.1.4 Physical Characteristics

a. Perform dimensional and physical specification procedures of MTP 10-2-500 which apply to the aviation clothing under test.

b. Perform the following measurements and record the results.

- 1) Chest - Measure across the chest area, from side seam to side seam, at the bottom of the armholes.
- 2) Sleeve length - Measure along the sleeve inseam, from



MTP 7-2-087.  
19 March 1971

- the base of the armhole to the bottom of the cuff.
- 3) Leg inseam length - Measure along the leg inseam, from the center of the crotch to the bottom of the leg.
  - 4) Neck - Measure neck size and compare with size marking in the garment.
  - 5) Coat length - Measure from top of collar down center of the back.
  - 6) Trouser waist - Measure waist band and compare with size marking in the garment.

c. Match the test item fabric/material with a sample of approved/desired shade under natural (north sky) or artificial daylight having a color temperature of 7500 degrees Kelvin. Record whether or not the desired color match was achieved.

d. Identify test item stitches, seams, and stitchings, by classification, in accordance with the criteria of FED-STD-751.

e. Determine from appropriate test item material samples the physical properties of each textile test item type listed below according to the indicated method(s) of FED-SPEC-CCC-T-191.

- 1) Weight, Method 5100.
- 2) Breaking strength, Method 5100.
- 3) Tear Strength, Method 5134.
- 4) Bursting strength, Method 5122.
- 5) Resistance to water, Method 5512.
- 6) Thickness, Method 5030.
- 7) Flame Resistance, Method 5903.

f. Determine from appropriate test item material samples the physical properties listed below for each elastomer test item (or test item component) according to the indicated methods of Federal Test Method Standard No. 601.

- 1) Elongation, Method 4121.
- 2) Tensile strength, 500% elongation, Method 4111.
- 3) Tensile strength at break, Method 4111.
- 4) Hardness, Method 3021.

#### 6.1.5 Preparation of Testing Apparatus

##### 6.1.5.1 Water-Repellency Test Setup Preparation

a. Prepare a solution for the impregnation of the indicator paper by combining and dissolving fifty grams of cobaltous chloride and two hundred grams of calcium chloride in one liter of water.

b. Place the apparatus equivalent to that illustrated by Figure 1 on a level bench and connect the pressure regulator to a compressed air line. Make other connections as illustrated by Figure 1.

c. Test the apparatus for leaks as follows:

- 1) Place a soft rubber sheet across the cup in the holder.

NOTE: Refer to Figure 1 for identification of components discussed in this procedure.

- 2) Close the exhaust cock and open the shutoff cock; allow the water to rise to about 30 inches as indicated on the manometer scale.
- 3) Close the shutoff cock.
- 4) Observe the manometer water level. If the indicated level falls at a rate greater than one inch per minute, a serious leak exists and should be corrected. A constant water level for a period greater than one minute indicates the apparatus is suitable for use.

d. Soak folded paper towelling in the impregnating solution (see step a. above) for 20 to 30 minutes.

e. Remove the paper, unfold, and dry in an oven until the paper is blue. Cut into two and one-half inch squares.

NOTE: Should the prepared indicator paper become moist in room air (indicated by turning orange), restore the blue color by heating the paper slightly or by storing in a dry container.

#### 6.1.5.2 Anti-Exposure Clothing Leakage Test Solution

Prepare, in the quantity required for the number of anti-exposure garments to be tested, a solution of soap and water combined in the following proportions:

- a. Ten percent soap.
- b. Ninety percent water.

#### 6.1.6 Preparation for Transportability Test

Pack the test item as follows:

- a. In military pack for overseas shipment.
- b. Limited military pack for domestic shipment.

MTP 7-2-087  
19 March 1971

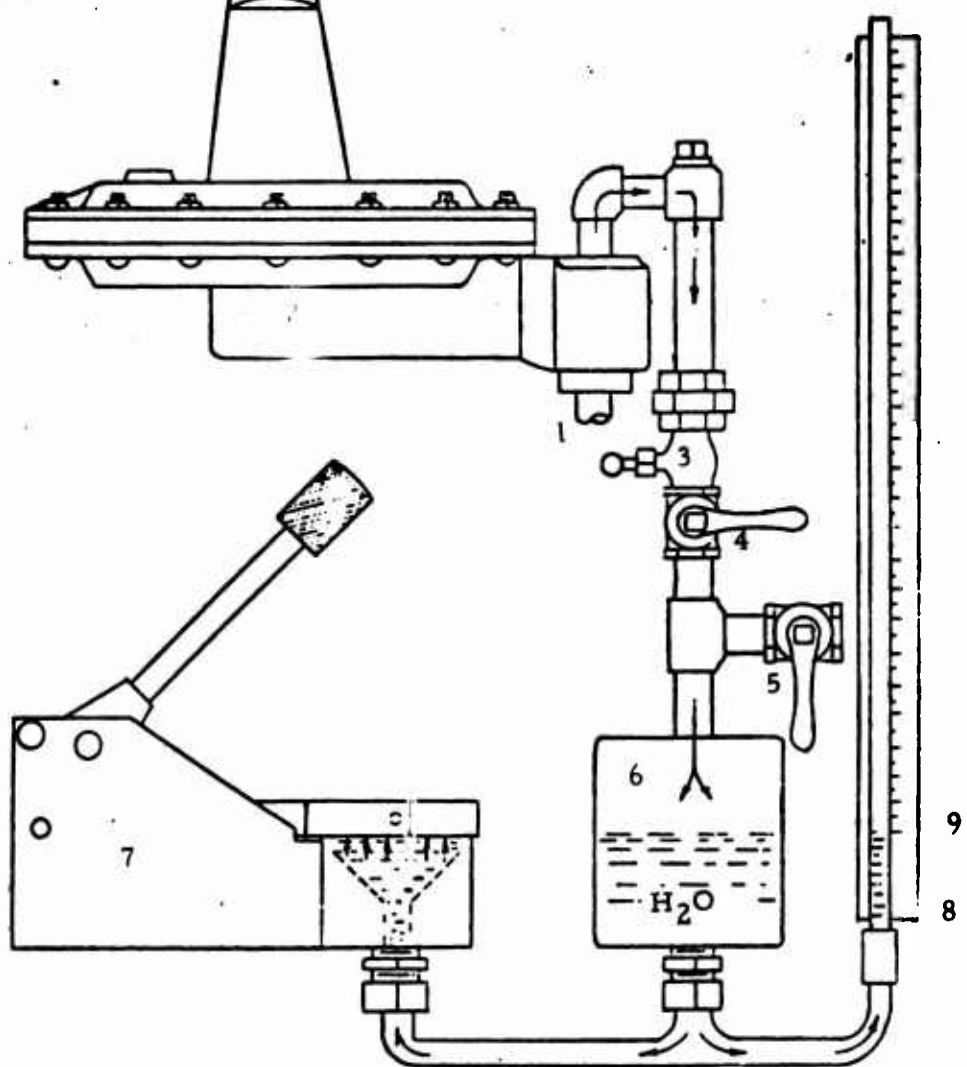

<u>ITEM</u>	<u>DESCRIPTION</u>
1	COMPRESSED-AIR INLET
2	PRESSURE REGULATOR
3	NEEDLE VALVE
4	SHUT-OFF COCK
5	EXHAUST COCK
6	WATER RESERVOIR
7	SPECIMEN HOLDER
8	GLASS MANOMETER
9	MANOMETER SCALE

FIGURE 1: SCHEMATIC DIAGRAM FOR WATER-REPELLENCY TEST SET-UP

c. Minimum military pack for domestic shipment with immediate use at initial destination.

NOTE: Packing techniques and exterior containers used to pack the test item for shipment according to the levels specified above will be in accordance with the preparation for shipment section of the draft technical manual.

#### 6.1.7 Operator Training and Familiarization

Test personnel shall receive training and familiarization in accordance with applicable procedures of MTP 10-2-501 and the following:

a. Instruct all test personnel in test item operation and maintenance.

b. Copies of the draft or preliminary technical manual and written safety instructions will be issued to each test team member.

c. Familiarize the test team concerning the purpose and methods required to test aviation clothing. The following topics should be stressed during these familiarization sessions:

- 1) Sequence of tests and Adjustment: Tests and adjustments should be carried out in the specified order so that factors affecting each test will have been established and re-testing and re-adjustment will be reduced or eliminated.
- 2) Test Equipment: Ensure that each team member understands the requirement for each specified test equipment and test fixture.
- 3) Terminology: Familiarize team members with trade terms and unique state-of-the-art terminology not otherwise defined in the supplied instructional matter.
- 4) Hazards: Review all hazards and safety precautions associated with operating, maintaining, repairing and testing the test item.

d. Assess the value of the training and familiarization. Personnel who do not demonstrate adequate understanding of the material presented shall receive additional instruction. Record the name, rank, past experience, and degree of retraining required.

e. Prior to official testing, the various test apparatus should be operated by applicable team members for the purpose of familiarization with the test procedures and to verify satisfactory performance of each test set-up. Test director evaluation of test personnel as a team should be recorded at the completion of this step.

MTP 7-2-087  
19 March 1971

f. Record rank, unit, experience, and previous training for each team member. Also, record the adequacy of the supplied technical manuals for training purposes.

6.2 TEST CONDUCT

NOTE: All material malfunctions shall be reported in accordance with USATECOM Regulation 705-4.

6.2.1 Sizing and Fitting Test

Determine the sizing and fitting characteristics of the test item as a complete ensemble or as related to wear with other aviation clothing, as applicable.

a. Process the total number of participating test subjects through a sizing procedure. Measure and record the following data for each test subject:

- 1) Height.
- 2) Weight.
- 3) Chest dimension.
- 4) Arm dimension.
- 5) Hip dimension.
- 6) Inseam.
- 7) Shoulder (width and epth).
- 8) Waist.

NOTE: 1. Techniques and procedures for obtaining the measurements required above may be found in TM 700-8400-1.

2. Personnel selected as test subjects for this test should, in an overall manner, reflect the statistical distribution of the group for which the clothing is intended or the 5th, 50th, and 95th percentile, as applicable.

b. Using the data collected in step a. and the sizing information available on the test garment, predict a test item garment size for each test subject. Issue the size predicted. Record, prior to test item donning, the size prediction for each test subject.

c. Instruct test subject to don their respective test item garments.

d. Following step c., a qualified inspector should examine each test subject and rate the quality of apparent fit as good, fair, or poor. Where poor fit ratings were given, subsequent fittings should be made until a good or fair test item fit is obtained. Record in tabular form the results

of this step.

e. Where the test item is not a complete ensemble, steps c. and d. should be performed with each test subject fitted beforehand with other aviation clothing specified for the intended aviation mission, environmental condition, or both.

#### 6.2.2 Donning and Doffing Test

Determine the characteristics of the test item which affect the ease of donning/doffing and the time, human assistance, or materials (furnished or not furnished) required.

NOTE: The donning and doffing tests may be conducted during or following 6.2.1; the procedures, however, are detailed separately in the interest of clarity.

a. Using the information obtained from test subject measurements of 6.2.1 step a. and the following, a successful test item fit (also see 6.2.1 steps c., d., e.) instruct test participants to don and doff the test item(s) a minimum of three times each over other clothing if appropriate to the aviation garment under test. The following donning/doffing instructions are provided for general guidance in the absence of specific provisions to the contrary.

- 1) Donning sequence:
  - a) Remove outer garments, i.e., flight jackets, flight coveralls, boots, helmet, gloves, etc.
  - b) Don the liner for winter flight suit, coverall, anti-exposure suit, etc.
  - c) Don the test item.
- 2) Doffing sequence: Reverse the donning sequence.

b. Record the following data for each test subject:

- 1) Time required to don the test item.
- 2) Time required to doff the test item.
- 3) Assistance required, human or material, i.e., shoe-horn, etc.
- 4) Difficulties encountered.

c. Interview (or issue questionnaires to) each participant. Record the opinion of these persons in regard to the ease of donning and doffing test item. In particular, quiz each test participant (test subjects, fitters, observers, and inspectors) on the following, phrasing the questions to obtain direct, specific answers.

- 1) Suitability of test item fastenings and adjustments.
- 2) Ability to effect fastenings and adjustments.
- 3) Apparent difficulties observed by qualified observer/recorder.

MTP 7-2-087  
19 March 1971

- 4) Ease of donning and doffing the test item over clothing, other aviation garments, and/or equipment.

6.2.3 Compatibility with Associated Aviation Clothing and Personal Equipment

Determine test item interface characteristics with existing or under-development aviation clothing and personal equipment. Proceed as follows:

a. During all tests conducted, observe the test item being worn and record the opinions of test participants relative to the compatibility of the test item with the following:

- 1) Standard footwear.
- 2) Headwear.
- 3) Handwear.
- 4) Other protective devices for the head and face.
- 5) Aircraft seats.
- 6) Parachutes.
- 7) Oxygen supply accessories, e.g., hoses, clamps, suspension devices.

b. Whenever the test item appears not to be compatible with a specific item or items, perform the following.

- 1) Select subjects of various sizes in sufficient numbers to represent an adequate sample size. Size, fit, and don the test item and aviation clothing exhibiting the interface restriction.
- 2) Instruct the test subjects to perform various feats of mobility such that the item(s) in question is(are) stressed at the interface.
- 3) Record the following:
  - a) Identification of test item size or type which caused an interface difficulty.
  - b) Identification of aviation clothing accessory or equipment involved.
  - c) Mobility feat which stressed the interface in question.
  - d) Explain in detail the nature of the physical interface problem, including measurements when applicable and practical.

6.2.4 Water/POL-Repellency and Cleaning

6.2.4.1 Water-Repellency Test

Determine the hydrostatic head which can be supported by a

sample of test item material before water penetration occurs. Use Method 603.1 of MIL-STD-282, which is summarized by the following procedures:

- a. Set-up the testing apparatus according to procedures of 6.1.5.1 and as illustrated by Figure 1.
- b. Place a test item material specimen and a sheet of indicator paper on the cup in the base of the specimen holder. The indicator paper should be placed on top of the specimen.
- c. Clamp the movable jaw of the specimen holder by pressing down on the cam lever (See Figure 1).
- d. Close the air-exhaust cock and open the shut-off cock (see Figure 1).

NOTE: Observe the manometer and verify that the water rise is approximately one foot per minute. A fifteen second delay is not uncommon. If, however, the water rises too slowly or not at all, confirm that all filter screens used are clean.

e. Observe the indicator paper mounted on top of the test item specimen through the plastic viewing window as the water rises in the manometer. At the first sign of a color change in the indicator, e.g., from blue to orange, immediately read the water level on the manometer scale and close the shut-off cock. Record this reading on the manometer as "inches of water repellency."

f. Repeat the procedure using other randomly selected samples of the same test item material. Record results.

#### 6.2.4.2 Waterproofness - Fabric (Rain Test)

Subject appropriate test items to the conditions of Method 506 of MIL-STD-810 and/or Rain Test Course at USAGETA, Ft. Lee, Va. At the completion of the rain exposure period, visually inspect the test item for evidence of water damage or leakage. Weigh the test item before and following the rain exposure test for subsequent determination of moisture gain. Record data relating to the determination of test item waterproofness characteristics.

#### 6.2.4.3 Waterproofness - System (Rain Test)

Subject the test item and its components to a rain test and ascertain its adequacy as a "system".

#### 6.2.4.4 Resistance to POL Wetting Test

a. Obtain POL substances and liquids including JP-4 and hydraulic fluids likely to be used in the aircraft intended for test item



MTP 7-2-087  
19 March 1971

usage. Record the identification and, where applicable, the chemical composition of the testing materials/fluids.

b. Treat three separate locations of the test item with each POL substance. Record this data.

c. One minute following application of each POL substance, examine the area treated at an angle under light. Record the following regarding what is observed:

1) Absence of light reflection.

NOTE: Little or no light reflection is an indication of wetting of the test item fabric or material and shows evidence of poor repellency.

2) Light reflection.

3) Identification of those POL substances which "wet", e.g., did not reflect light at a near grazing angle, the test item.

#### 6.2.4.5 Cleaning

Determine the ease with which the test item may be cleaned and the change(s) in physical properties which accompany laundering or dry cleaning. Proceed as follows:

a. Consult the test item draft technical manual or attached labels for laundering or dry cleaning instructions.

b. Following the attached instructions, launder or dry clean the test item. Record the steps followed, and identify the materials, e.g., soap, etc., used.

c. Following dry cleaning or laundering, examine the test item and record evidence of stains, dirt, or other indications of improper cleaning. Test items should be re-cleaned until inspection reveals satisfactory evidence of adequate cleaning.

d. Test items which have been judged as adequately clean in accordance with the procedures of step c., should be subjected to the following tests.

- 1) Tear resistance test to be performed in accordance with Method 5132 of MIL-STD-CCC-T-191.
- 2) Shrinkage test to be performed in accordance with Method 7552 of MIL-STD-CCC-T-191.

e. Record the results of the MIL-STD-CCC-T-191 evaluations conducted under step d., the total time required for cleaning of each test item, and the opinion of the laundry/dry cleaning personnel regarding the ease with which the test item is cleaned.

6.2.5 Anti-Exposure and CBR Protective Clothing Tests

6.2.5.1 Leakage Test

a. Turn the garment to be tested inside out.

b. Close-off with suitable plugs or clamps all openings in the test item such as leg, neck, or arms entrance portals, with the exception of one. Record details of this step.

NOTE: Exercise caution when closing off the various test item entrance portals as test item material may easily be damaged in the application of plugs or clamps.

c. Introduce through the remaining test item opening and maintain an air pressure of not less than one-half p.s.i. nor more than three-fourth p.s.i. Record the actual value(s).

d. While the test item is inflated, apply the solution prepared under 6.1.5.2 to all seams and cemented areas. Allow the solution to extend well beyond the edges of the seam tapes.

e. During the conduct of step d., carefully observe the test item for bubbles which will indicate leakage. Mark any leaks discovered. Record test item identification and details of test.

6.2.5.2 High Temperature Exposure (Tackiness)

a. Obtain two basic samples of the test item basic fabric of an approximate size of two inches by two inches.

b. Sandwich the samples together between two glass plates of a slightly larger size.

c. Subject the combination of step b to a pressure of  $0.25 \pm .01$  pound per square inch.

d. Obtain a thermostatically controlled oven of a size suitable for containing the clamped test item samples and glass plates.

e. Subject the test item samples to two hours at 170 degrees F. in the test oven. Record actual values.

f. Following the timed heating period, remove the test item samples and cool in a conditioned atmosphere.

MTP 7-2-087  
19 March 1971

g. After five minutes, the samples should show no evidence of adhesion or exudation when separated. Record the results of this step and other details, as applicable.

6.2.6 Resistance to Generation of Static Electricity

Subject test item to the generation of static electricity test in accordance with procedure of AATCC Method No. 76-1964. Determine test item dielectric constant(s) constant(s) and dissipation factor. Record resulting data.

6.2.7 Endurance Tests

6.2.7.1 Slide Fastener Endurance Test

a. Obtain slide fasteners of the type used in the test item, i.e., breast, thigh, shin, front and hip opening, and cigarette pack, multiple pencil pocket(s).

b. Mount each slide fastener type in a testing device equivalent to that illustrated by Figure 2.

c. Each slide fastener type should be subjected to opening and closing for 10,000 cycles, at a uniform rate of 50  $\pm$ 5 cycles per minute. Record the following:

- 1) Number of test cycles accomplished.
- 2) Cycles per minute.
- 3) Evidence of mechanical failure(s).
- 4) Fastener lock or jam during test.
- 5) Any indication of interference when the slide is moved along the entire length of the chain.
- 6) Evidence slider position changed during test.

d. Following step c. for each slide fastener type, measure the force required to open and close the chain. Record the values.

e. For slide fasteners from anti-exposure garments, mount the slide fastener in the clothing for which it was intended. Subject the combination to the leakage test. Record evidence of leakage due to the slide fastener.

6.2.7.1 Extended Laundering Test

Determine the effects of extended laundering on the test item and establish the number of launderings the test item can be expected to withstand while maintaining satisfactory physical properties.

a. Launder the test item fifty times in accordance with the procedures of 6.2.4.4, Cleaning.

MTP 7-2-087  
19 March 1971

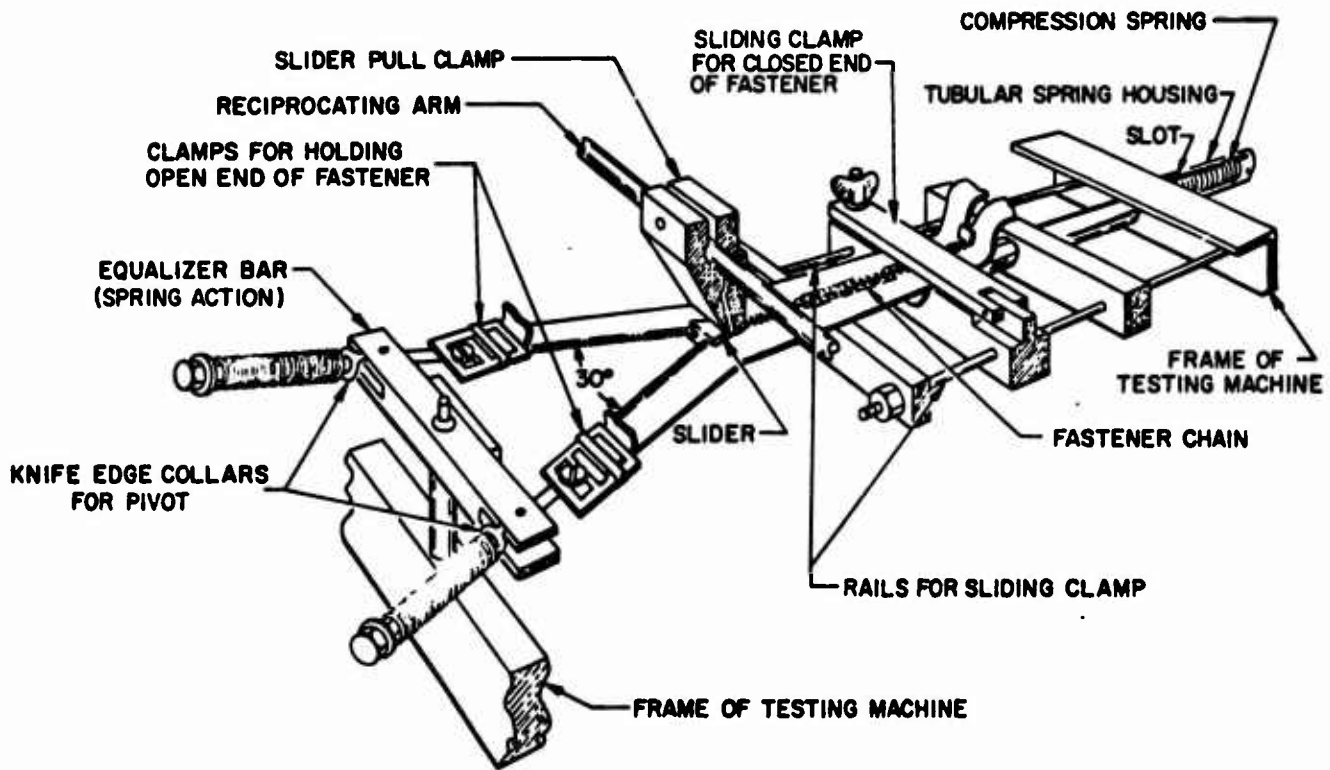

FIGURE 2: ENDURANCE TESTING MACHINE FOR SLIDE FASTENERS

MTP 7-2-087  
19 March 1971

b. Following the required number of laundering of step a., subject the test item to the physical properties tests of 6.1.4, Physical Characteristics. Record the resulting data.

c. Provided the test item exhibits physical characteristics within the limits of the governing documents, launder the test item not less than five but not more than ten times. Repeat step b, and record the physical property data. Determine the difference between data of this step and data of step b. If the physical property performance values have decreased by a large amount or have exceeded the allowable limits, it may be assumed that the test item's useful life span has been reached.

#### 6.2.7.2 Extended Dry Cleaning Test

Determine the effects of extended dry cleaning on the test item and establish the number of dry cleanings the test items can be expected to withstand and retain acceptable physical properties.

a. Dry clean each test item ten times.

b. Following the required number of dry cleanings of step a., perform the physical property determinations of 6.1.4, Physical Characteristics.

c. Provided the test item exhibits physical characteristics within the limits of the governing documents, dry clean the test item not less than five nor more than ten times. Repeat step b, and record the physical property data. Determine from the difference between data of this step and step b. If the physical property performance values have decreased by a large amount or have exceeded the allowable limits, it may be assumed that the test item's useful life span has been reached.

#### 6.2.8 Fungus Resistance Test

Subject the test item to the 28-day fungus resistance test in accordance with Procedure I of MIL-E-5272. At the end of the test, the test item should be examined visually and evidence of deterioration or other effects recorded. Perform 6.1.4., Physical Characteristics tests and record changes in physical properties as applicable.

#### 6.2.9 Sunshine Test

Subject the test item or samples of test item materials to the 48-hour radiant energy test in accordance with Procedure I of MIL-E-5272. At the end of the test, test item parts should be examined visually and evidence of deterioration or other effects recorded. Conduct 6.1.4 Physical Characteristics tests and record changes in physical properties, as applicable.

#### 6.2.10 Maintenance Evaluation

Evaluate the maintenance-related factors of the test item as described in MTP 10-2-507 with emphasis on the following:

- a. Organization (O), Direct Support (F), and General Support (H) maintenance requirements.
- b. Operator through General Support Maintenance Literature, if applicable.
- c. Repair parts.
- d. Calibration standards and facilities.
- e. Test and handling equipment.
- f. Maintenance facilities.
- g. Personnel skill requirements.
- h. Maintainability.

i. Achieved Availability - To evaluate the achieved availability of the test item, ensure that sufficient data is logged on the special analysis charts to be able to determine the two factors, mean-time-between-maintenance (MTBM) and mean active maintenance downtime ( $\bar{M}$ ) resulting from both preventive and corrective maintenance actions. At the completion of testing, extract and summarize this data and compute achieved availability ( $A_a$ ) using the following formula:

$$A_a = \frac{MTBM}{MTBM + M} \quad \text{(Reference USATECOM Regulation 750-15, Appendix A)}$$

NOTE: Ensure that data is collected in accordance with USATECOM Regulation 750-15, Appendixes A and B.

#### 6.2.11 Reliability

Evaluate and appraise the reliability related factors of the test item as described in MTP 10-2-512.

#### 6.2.12 Transportability

NOTE: Perform this test only if some special feature is involved which would necessitate a transportability evaluation.

Prepare the test item for shipment in accordance with paragraph 6.1.6, Preparation for Transportability Test. Subject the

MTP 7-2-087  
19 March 1971

packaged test item to the transportability characteristics determinations of MTPs 10-2-503 and 7-2-509.

6.2.13            Safety

Provide a safety release recommendation in accordance with USATECOM Regulation 385-6 and observe all known safety precautions of the test item and equipment used in determining performance characteristics. Perform applicable procedures of MTP 7-2-506 and the following:

a. Determine the flame resistant characteristics of applicable test items through application of Method 5903 of FED-SPEC-CCC-T-191. Record after flame duration, char length, and other details of the test.

b. Rate the test item as good, fair, or poor in regard to construction characteristics or authorized accessories which would tend to catch or snag on typical aircraft components.

c. Rate and record the overall safety features of the test item as good, fair, or poor in regard to the presence of retrieving straps, the percentage of skin area covered, and other design characteristics which assist in rescue or prevent human injury.

d. Throughout all tests observe and record the presence of any dangerous or unsafe condition which presents or possibly presents a safety hazard, including the cause of the hazard.

e. Observe and record the adequacy of warning instructions and markings.

f. Record any suggestions to improve the existing design for safety.

6.2.14            Human Factors Evaluation

Determine the degree to which test item physical design and revealed performance characteristics conform to recognized human factors engineering design criteria. Prepare checklists of design criteria applicable to Class IVC material as defined by Human Factors Evaluation Data for General Equipment (HEDGE), incorporate applicable procedures of MTP 10-2-505, and perform the following:

a. General considerations to be included in checklists for all tests:

- 1) Adequacy of furnished instructions.
- 2) Human factors design deficiency revealed by particular test.

b. Individual considerations to be included in checklists for all tests:

- 1) User's comfort while wearing test item and his ability to perform required tasks with minimal restrictions.
- 2) Ease of donning and doffing.
- 3) Ease of removing in emergency situations.
- 4) Fit snugly at openings for winter, anti-exposure and CBR test item types.
- 5) Ease of using fastening systems.
- 6) Compatibility with other necessary personal equipment.

c. During all tests that require the test subject to perform mobility feats, determine through the wearer's opinions and the observations of qualified participants the freedom of movement. Record the particular body positions and mobility feat(s) which caused a restriction in the wearer ability to move normally or which were uncomfortable during the mobility task.

d. Record any recommendations to improve man-item effectiveness.

#### 6.2.15 Value Analysis

Throughout all tests, the test item shall be examined for any unnecessary, costly, "nice-to-have" features as described in USATECOM Regulation 700-1. Perform the following:

a. During operation of the test item, observe for features which could be eliminated without compromising performance, reliability, durability, or safety.

b. Question test personnel regarding features of the test item which could be eliminated without decreasing the functional value of the test item or decrease man-item effectiveness.

c. Record the following:

- 1) Non-functional, costly, or "nice-to-have" features of the test item.
- 2) Test personnel comments and opinions regarding features to be eliminated.

#### 6.2.16 Quality Assurance

Throughout all tests, examine the test item for compliance with the quality requirements of the applicable MN and the provisions of MTP 10-2-511.



MTP 7-2-087  
19 March 1971

6.3 TEST DATA

NOTE: In compiling the Test Data section, test personnel should expound upon those data procedures which are other than quantitative in nature by recording narrative descriptions which will provide full details of conditions and/or events occurring during the conduct of the test.

6.3.1 Initial Inspection

Record the following:

- a. Evidence of damage incurred during transport or storage.
- b. Exterior identification markings not in accordance with MIL-STD-129 or other governing documents.
- c. Evidence of the following:
  - 1) Any hole, scissors or knife cut, tear, mend, or weakening defect.
  - 2) Stiffened, hardened, or seared cloth/material caused by thermoactivated shade and size marking tickets attachment.
  - 3) Twisted, puckered, or pleated seams.

6.3.2 Inventory Check

Record the following:

- a. Missing maintenance literature or draft technical manuals.
- b. Shortages in accessories.

6.3.3 Inspection and Preliminary Operation

Record the following:

- a. Test item labels not in accordance with MIL-STD-130 or DDD-L-20.
- b. Defects found during an inspection of the test item:
  - 1) Slide fasteners.
  - 2) Fastener tape.
  - 3) Seams.
  - 4) Stitching.
  - 5) Front openings, if applicable.
  - 6) Pockets, breasts, thigh, shin, knife, etc.

- 7) Hip openings.
- 8) Sleeves.
- 9) Waistband or waistband tunnel.
- 10) Hanger.

6.3.4 Physical Characteristics

Record the following:

a. Dimensional and physical specification data required by applicable procedures of MTP 10-2-500.

b. Size measurements:

- 1) Chest.
- 2) Sleeve length.
- 3) Leg inseam length.
- 4) Neck.
- 5) Coat length.
- 6) Trouser waist.

c. Degree of color match achieved between test item and standard sample of desired color.

d. Identification of stitches, seams, and stitchings by classification in accordance with criteria of MIL-STD-751.

e. Textile Physical Properties tested according to FED-SPEC-CCC-T-191:

- 1) Weight.
- 2) Breaking strength.
- 3) Tear strength.
- 4) Bursting strength.
- 5) Resistance to water.
- 6) Thickness.
- 7) Flame resistance.

f. Elastomer physical properties tested according to Federal Test Method Standard No. 601.

- 1) Elongation.
- 2) Tensile strength, 500% elongation.
- 3) Tensile strength at break.
- 4) Hardness.

6.3.5 Operator Training and Familiarization

Record the following:

MTP 7-2-087  
19 March 1971

- a. Data required by MTP 10-2-501.
- b. For personnel requiring retraining:
  - 1) Name.
  - 2) Rank.
  - 3) Past experience.
  - 4) Degree of re-training required.
- c. Test director evaluation of test personnel as a team.
- d. For each team member:
  - 1) Rank.
  - 2) Unit.
  - 3) Experience.
  - 4) Previous training.
- e. Adequacy of technical manual(s) for training purposes.

6.3.6 Sizing and Fitting Test

Record the following:

- a. For each test subject:
  - 1) Height, in inches.
  - 2) Weight, in pounds and ounces.
  - 3) Chest dimension, in inches.
  - 4) Arm dimensions, in inches.
  - 5) Hip dimensions, in inches.
  - 6) Inseam, in inches.
  - 7) Shoulder, in inches.
  - 8) Waist, in inches.
- b. The predicted size data for each test subject.
- c. Availability of proper size for each test subject and the quality of fit rated as good, fair, or poor for each fit.

6.3.7 Donning and Doffing Test

Record the following data for each test subject following the donning and doffing operations:

- a. Time required to don the test item.
- b. Time required to doff the test item.
- c. Assistance required, human or materiel, i.e., shoe-horn, etc.

d. Difficulties encountered.

f. Subjective opinions of test participants regarding ease of donning and doffing test item, including answers to such questions as:

- 1) Suitability of test item fastenings and adjustments.
- 2) Ability to effect fastenings and adjustments.
- 3) Apparent difficulties observed by qualified observer/recorder.
- 4) Ease of donning and doffing test item over clothing, other aviation garments, and/or equipment.

6.3.8 Compatibility with Associated Aviation Clothing and Personal Equipment

Record the following:

a. Test participant opinions regarding compatibility of the test item with the following items:

- 1) Standard footwear.
- 2) Headwear.
- 3) Handwear.
- 4) Other protective devices for the head and face.
- 5) Aircraft seats.
- 6) Parachutes.
- 7) Oxygen supply accessories, e.g., hoses, clamps, suspension devices.

b. Following specific interface tests:

- 1) Identification of test item size or type which caused an interface difficulty.
- 2) Identification of aviation clothing accessory or equipment involved.
- 3) Mobility feat which stressed the interface in question.
- 4) Details of the interface difficulty, including measurements when applicable and practical.

6.3.9 Water-Repellency Test

Record in inches of water, repellency taken from the manometer for randomly selected samples of test item material.

6.3.10 Waterproofness - Fabric (Rain Test)

Record the data required by Method 506 of MIL-STD-810 and/or Rain Test Course at Ft. Lee and the following:

MTP 7-2-087  
19 March 1971

- a. Weight of test item prior to test, in pounds and ounces.
- b. Weight of test item following rain test, in pounds and ounces.
- c. Moisture gain, in ounces.

6.3.11 Waterproofness - System (Rain Test)

Record the adequacy of the test item and its components when used as a system.

6.3.12 Resistance to POL Wetting Test

Record the following:

- a. Identification and chemical composition of the testing materials/fluids.
- b. Light reflection present or not.
- c. Identification of POL substances which "wet" the test item, e.g., did not reflect light at a near grazing angle.

6.2.13 Cleaning

Record the following:

- a. Steps followed and equipment used to launder or dry clean the test item.
- b. Identification of the cleaning agent(s).
- c. Following the cleaning operation:
  - 1) Evidence of stains, dirt, or other indications of improper cleaning.
  - 2) Re-cleaning necessary to eliminate evidence of improper initial cleaning, if possible.
- d. Results of the following tests:
  - 1) Tear resistance of CCC-T-191.
  - 2) Shrinkage test of CCC-T-191.
- e. Total time to clean test item.
- f. Opinions of launder/dry cleaning personnel in regard to ease of cleaning test item.

6.3.14            Leakage Test

Record the following:

- a. Details of closing-off or plugging the test item entrance portals.
- b. Pressure introduced and maintained for test, in p.s.i.g.
- c. Indications of bubbles. Mark location on test item also.

6.3.15            High Temperature Exposure (Tackiness)

Record the following:

- a. Temperature at which test item sample was maintained, in degrees F.
- b. Length of time test sample was held at temperature of a. above, in hours.
- c. Length of time in conditioned atmosphere following test period, in minutes.
- d. Following conditioning, evidence of test item adhesion or exudation when separated.

6.3.16            Resistance to Generation of Static Electricity

Record data required by procedures of AATCC Method No. 76-1964.

6.3.17            Slide Fastener Endurance Test

Record the following:

- a. Number of test cycles accomplished.
- b. Cycles per minute.
- c. Evidence of fastener mechanical failure.
- d. Fastener lock or jam during test.
- e. Indication of interference when slide is moved along the entire length of the chain.
- f. Force required to open and close the chain, in ounces.
- g. Evidence of leakage following endurance test cycles.

MTP 7-2-087  
19 March 1971

6.3.18            Extended Laundering Test

Record the following:

a. Following the required number of extended launderings the data required by re-testing of 6.1.4, Physical Characteristics.

b. Total number of launderings accomplished prior to a physical property indicating out-of specification values.

6.3.19            Extended Dry Cleaning Test

Record the following:

a. Following the required number of extended dry cleanings, the data required by re-testing of 6.1.4, Physical Characteristics.

b. Total number of dry cleanings accomplished prior to a physical property indicating out of specification values.

6.3.20            Fungus Resistance Test

Record the data resulting from the conduct of Procedure I of MIL-E-5272.

6.3.21            Sunshine Test

Record the data resulting from the conduct of Procedure I of MIL-E-5272.

6.3.22            Maintenance Evaluation

Record data required by applicable procedures of MTP 10-2-507 and Appendixes A and B to USATECOM Regulation 750-15. Also record the following:

a. Mean-time-between-maintenance (MTBM).

b. Mean active maintenance downtime ( $\bar{M}$ ).

c. Calculated value of achieved availability ( $A_a$ ).

6.3.23            Reliability

Record data required by applicable procedures of MTP 10-2-512.

6.3.24            Transportability

If specific transportability aspects were covered, record the data required by applicable procedures of MTP's 10-2-503 and 7-2-509.

6.3.25            Safety

Record the following:

- a. Data required by applicable procedures of MTP 7-2-506.
- b. Data required by conduct of Method 5903 of FED-SPEC-CCC-T-191.
  - 1) Char length.
  - 2) Other details.
- c. Subjective judgment regarding adequacy of test item design to minimize snags on the aircraft or its components, as good, fair, or poor.
- d. Sum up test item features in regard to rescue operations as good, fair, or poor.
- e. Dangerous or unsafe features of the test item which were noted during testing.
- f. Adequacy of warning instructions and markings.
- g. Suggestions for improving test item design from the standpoint of safety.

6.3.26            Human Factors Evaluation

Record the following:

- a. Data required by applicable procedures of MTP 10-2-505.
- b. Fill out and complete checklists including:
  - 1) General considerations.
  - 2) Individual considerations.
- c. Feats of mobility including description of body position which caused the wearer discomfort or restricted movement.
- d. Areas of noncompatibility with other items of personal equipment.
- e. Recommendations for improvements in man-item effectiveness.

6.3.27            Value Analysis

Record the following:



MTP 7-2-087  
19 March 1971

- a. Nonfunctional, costly, or "nice-to-have" features of the test item.
- b. Test personnel comments and opinions regarding features to be eliminated.

6.3.28            Quality Assurance

Record the following:

- a. Data required by MTP 10-2-511.
- b. Comments as to any design shortcomings in the area of required quality.

6.4                DATA REDUCTION AND PRESENTATION

- a. Data obtained during the conduct of the engineering tests shall be summarized, tabulated, and displayed in a manner which will facilitate evaluation. Reference clothing test data will be displayed for easy comparison with the appropriate test item(s).
- b. Physical characteristics test data will be evaluated as required by appropriate specification test methods for comparison with the technical performance characteristics specified by the MN or other governing documentation.
- c. Photographs, charts, and narrative descriptions will be made available during the evaluation.
- d. Recommendations should be provided in regard to the test item(s) suitability for service testing.

UNCLASSIFIED

Security Classification

DOCUMENT CONTROL DATA - R & D

(Security classification of title, body of abstract and indexing annotation must be entered when the overall report is classified)

1. ORIGINATING ACTIVITY (Corporate author) U.S. Army Test and Evaluation Command Aberdeen Proving Ground, Maryland 21005		2a. REPORT SECURITY CLASSIFICATION UNCLASSIFIED	
		2b. GROUP -----	
3. REPORT TITLE  U.S. Army Test and Evaluation Command Materiel Test Procedure Commodity Engineering Test Procedure "Clothing (Aviation)"			
4. DESCRIPTIVE NOTES (Type of report and inclusive dates) Final			
5. AUTHOR(S) (First name, middle initial, last name)  -----			
6. REPORT DATE 19 March 1971	7a. TOTAL NO. OF PAGES 34	7b. NO. OF REFS 21	
8a. CONTRACT OR GRANT NO.		8b. ORIGINATOR'S REPORT NUMBER(S)  MTP 7-2-087	
b. PROJECT NO.  c. AMCR 310-6	8d. OTHER REPORT NO(S) (Any other numbers that may be assigned this report)  -----		
10. DISTRIBUTION STATEMENT  Distribution of this document is unlimited.			
11. SUPPLEMENTARY NOTES  -----		12. SPONSORING MILITARY ACTIVITY Headquarters U.S. Army Test and Evaluation Command Aberdeen Proving Ground, Maryland 21005	
13. ABSTRACT  This document provides test methodology and testing techniques necessary to determine the technical performance and safety characteristics of aviation tools and associated accessories as described in Materiel Needs (MN) and to determine the item's suitability for service tests.			

DD FORM 1473 1 NOV 66

REPLACES DD FORM 1473, 1 JAN 64, WHICH IS OBSOLETE FOR ARMY USE.

UNCLASSIFIED

34

16. KEY WORDS	LINK A		LINK B		LINK C	
	ROLE	WT	ROLE	WT	ROLE	WT
Clothing (Aviation) Flying coveralls Flight suits						

ACCESSION NO. \_\_\_\_\_

CFBTI \_\_\_\_\_

DDC \_\_\_\_\_

UNANNOUNCED \_\_\_\_\_

JUSTIFICATION \_\_\_\_\_

BY \_\_\_\_\_

DISTRIBUTION/AVAILABILITY CODES

DIST.	AVAIL.	MM/OF	SPECIAL
A			