

AD719917

CO<sub>2</sub> LASER PULSING TECHNIQUES  
SEMI ANNUAL REPORT  
28 FEBRUARY 1971

---

**NORTHROP**

Reproduced by  
NATIONAL TECHNICAL  
INFORMATION SERVICE  
Springfield, Va. 22151

**DISTRIBUTION STATEMENT A**  
Approved for public release  
Distribution Unlimited

D D C  
RECORDED  
MAR 15 1971  
REGISTRY  
C

**BEST  
AVAILABLE COPY**

CO<sub>2</sub> LASER PULSING TECHNIQUES  
SEMI ANNUAL REPORT  
28 FEBRUARY 1971

Office of Naval Research  
Contract No. N00014-71-C-0185  
December 1969 to December 1971

Prepared by  
Electromagnetics Laboratory  
Northrop Corporate Laboratories

Sponsored by  
Advanced Research Projects Agency  
Order No. 306

Principal Investigator: Dr. M. L. Bhaumik  
Tel: AC 213 675-4611, Ext 4925  
Project Scientist: Dr. M. M. Mann

**NORTHROP CORPORATE LABORATORIES**

3401 West Broadway  
Hawthorne, California 90250  
Telephone (213) 675-4611

DISTRIBUTION STATEMENT A  
Approved for public release  
Distribution unlimited

DDC  
RECEIVED  
MAR 15 1971  
C

100001

## DOCUMENT CONTROL DATA - R &amp; D

Accuracy of the abstract and title fields of abstract and index only. Annotations must be entered when the overall report is classified.

Organization, address, and telephone number.

NORTHROP CORPORATE LABORATORIES  
3401 WEST BROADWAY  
HAWTHORNE, CALIFORNIA

7a. REPORT SECURITY CLASSIFICATION

UNCLASSIFIED

7b. GROUP

--

8. REPORT TITLE

CO<sub>2</sub> LASER PULSING TECHNIQUES

9. DESCRIPTIVE NOTES (Type of report and inclusive dates)

SEMI ANNUAL REPORT - 28 FEBRUARY 1971

10. AUTHOR(S) (Last name, middle initial, first name)

M. M. Mann

11. REPORT DATE

FEBRUARY 1971

12. TOTAL NO OF PAGES

12

13. NO OF REFS

2

14. CONTRACT OR GRANT NO

Contract N00014-71-C-0185

15. ORIGINATOR'S REPORT NUMBER(S)

NCL 71-15R

16. PROJECT NO

17. OTHER REPORT NO(S) (Any other numbers that may be assigned this report)

--

18. DISTRIBUTION STATEMENT

NONE

19. SUPPLEMENTARY NOTES

NONE

20. SPONSORING MILITARY ACTIVITY

OFFICE OF NAVAL RESEARCH  
DEPARTMENT OF THE NAVY  
ARLINGTON, VIRGINIA 22217

21. ABSTRACT

Simultaneous mode locking and pulse coupling of a CO<sub>2</sub> laser has been achieved using a single internal GaAs element with electrodes on both the (001) and (110) faces. Coupling of pulses from the laser did not affect the stability of the mode locked pulse train. Possible application of the technique to pulse code modulation of the CO<sub>2</sub> laser is discussed. (U)

14	KEY WORDS	LINE A		LINE B		LINE C	
		ROLE	WT	ROLE	WT	ROLE	WT
	CO <sub>2</sub> Lasers Lasers Gas Lasers Laser Pulsing Mode Locking						

## NOTICE

The views and conclusions contained in this document are those of the authors and should not be interpreted as necessarily representing the official policies, either expressed or implied, of the Advanced Research Projects Agency or the U. S. Government.

## ABSTRACT

Simultaneous mode locking and pulse coupling of a CO<sub>2</sub> laser has been achieved using a single internal GaAs element with electrodes on both the (001) and (110) faces. Coupling of pulses from the laser did not affect the stability of the mode locked pulse train. Possible application of the technique to pulse code modulation of the CO<sub>2</sub> laser is discussed.

## SUMMARY

This is the second semi-annual report of research performed under Office of Naval Research Contract No. N00014-~~71~~<sup>70</sup>-C-0185, sponsored by the Advanced Research Projects Agency. The work was performed by the Laser Group of the Electromagnetics Laboratory, Northrop Corporate Laboratories. The Principal Investigator of the program is Dr. M. L. Bhaumik and the Project Scientist is Dr. M. M. Mann. Other contributors to the program include: Dr. W. B. Lacina, Mr. R. G. Eguchi and Dr. W. H. Steier.

The objective of this program is to investigate and develop CO<sub>2</sub> laser pulsing techniques. This technology is requisite to applications of the CO<sub>2</sub> laser in communications and ranging. One of the most attractive approaches from the standpoint of stability and modulator efficiency appears to be coupling modulation of a mode-locked laser. Current effort is being directed at developing and evaluating this technique.

During the period covered by this report, simultaneous mode locking and pulse coupling was demonstrated using a single internal GaAs element with electrodes on both the (001) and (110) faces. A lower power r.f. driver tuned to a frequency approximately equal to the



axial mode interval (6.8 MHz) was applied across the (001) electrodes to produce locking, while the output coupling was varied by controlling the voltage applied to the orthogonal set of electrodes. Coupling of pulses from the laser did not affect the stability of the mode locked pulse train.

The experimental techniques and results are presented in greater detail in the Experimental Results section of this report. PCM experiments using this technology are in progress. In addition, a high pressure transverse discharge CO<sub>2</sub> laser has been constructed in order to extend the techniques to higher pulse rate and shorter pulse durations by exploiting the large pressure broadened linewidth available in this device.

## EXPERIMENTAL RESULTS

Simultaneous mode locking and coupling modulation of a CO<sub>2</sub> laser with the use of a single electrooptic element has been demonstrated. This technique may be used to achieve pulse code modulation of the CO<sub>2</sub> laser with a significant reduction in modulator drive power requirements as compared to conventional external modulation schemes. Bridges and Cheo previously demonstrated pulse dumping of a spontaneously locked Q-switched CO<sub>2</sub> laser.<sup>1</sup> The technique described here is suitable for CW operation.

The experimental configuration (Figure 1) was basically the same as that used for previously reported mode locking experiments<sup>2</sup> and is described in greater detail in that reference. The 22m folded optical resonator provided an axial mode separation of 6.8 MHz. All mirrors were total reflectors with the exception of M<sub>6</sub> which was a 5% transmitting dielectric coated germanium flat. The small spot size (~1 mm) and correspondingly large power density at M<sub>6</sub> caused rapid degradation of this reflector when the laser was operated CW. Therefore, for most of the experiments a slow speed chopper was placed inside the optical cavity to limit the duty to 0.5%. The chopper allowed lasing for periods sufficiently long (100 msec to 3 seconds) to establish CW operating conditions.

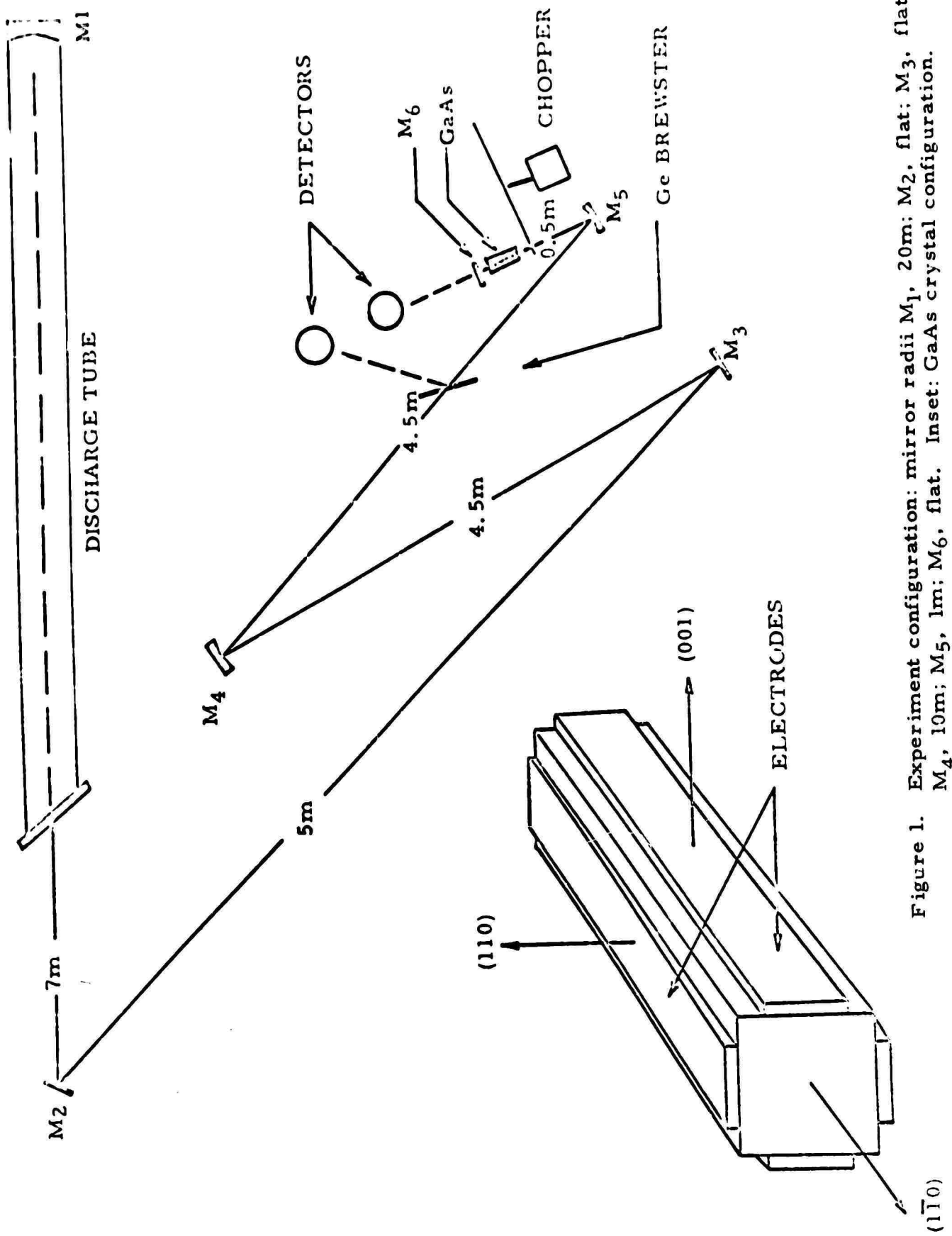

Figure 1. Experiment configuration: mirror radii  $M_1$ , 20m;  $M_2$ , flat;  $M_3$ , flat;  $M_4$ , 10m;  $M_5$ , 1m;  $M_6$ , flat. Inset: GaAs crystal configuration.

A 3 x 3 x 50 mm GaAs crystal with electrodes deposited on the (001) and (110) faces and AR coatings on the ( $\bar{1}\bar{1}0$ ) faces (see inset, Figure 1), was used both for locking and coupling. In the absence of a coupling signal, the optical field was polarized along the (110) direction.

A signal at the axial mode difference frequency with an amplitude of approximately 10V peak-to-peak was applied across the (001) faces to produce phase locking of the axial modes, as described in reference 2. Coupling of selected laser pulse(s) was effected by applying a voltage pulse on the (110) faces to induce a birefringence in the GaAs crystal. The resultant optical component polarized along (00 $\bar{1}$ ) was coupled out of the resonator by a polarization analyzer in the form of a germanium flat oriented at the Brewster angle. (The NaCl Brewster on the discharge tube provided insufficient polarization discrimination for this purpose.)

Liquid nitrogen cooled Ge:Cu detectors were employed, and power measurements were made with a calibrated thermopile. Peak intracavity pulse power in mode locked operation was 530w.

Figure 2 shows typical results. The coupling voltage pulse is displayed in the upper trace, the mode-locked pulse train observed through  $M_0$  is displayed in the center trace, and the coupled output pulse is shown in the lower trace. It should be noted that the center trace is delayed by one

Figure 2. Dumping of mode-locked pulse. Upper Trace - dumping voltage pulse.  
Center Trace - output through  $M_6$ . Lower Trace - coupled output.  
Horizontal scale 100 ns/div. (Center trace is delayed by one resonator  
round trip transit time).

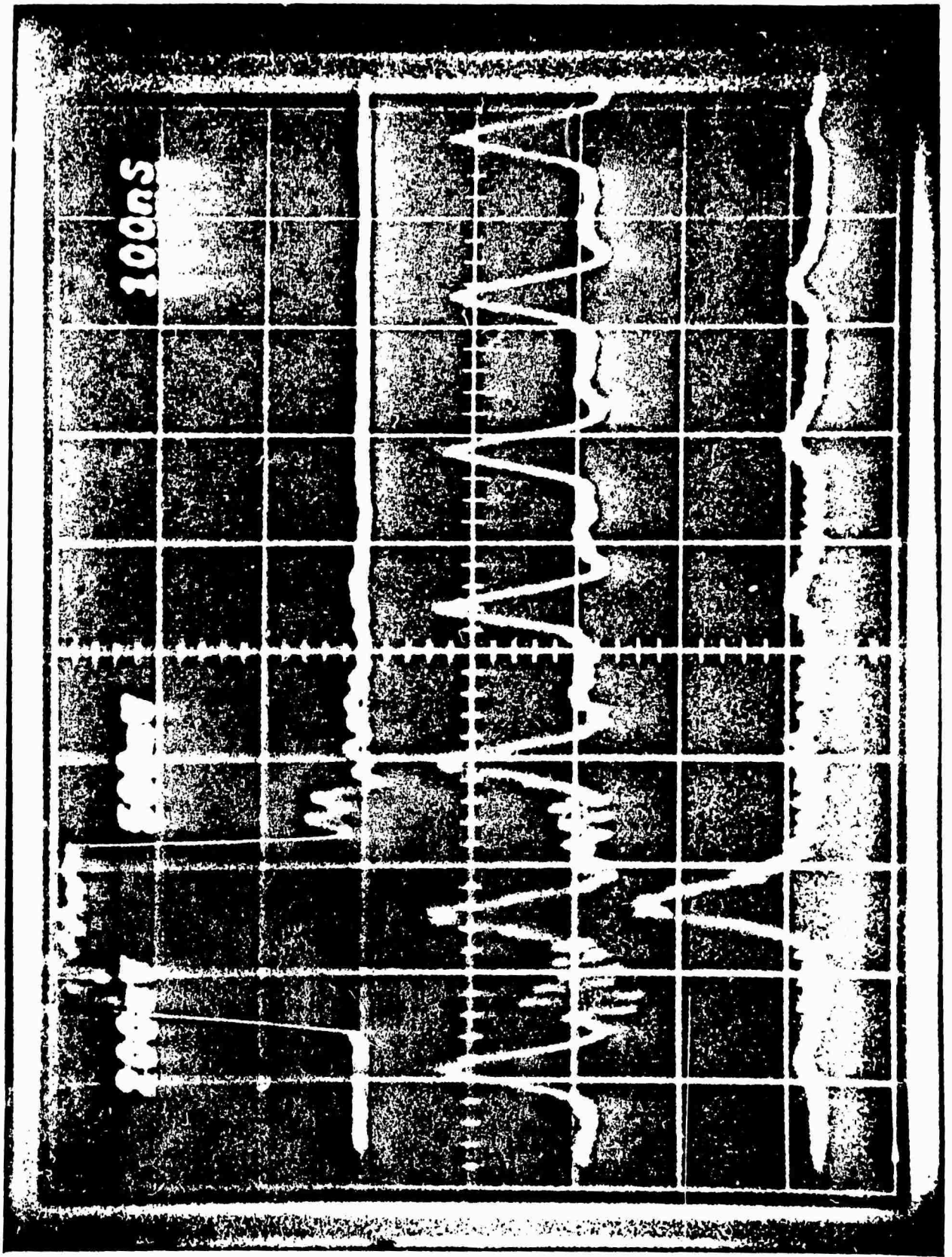

pulse period with respect to the lower trace, since it is necessary for the mode-locked pulse to complete a round trip in the resonator before being observed at  $M_6$ . The coupling voltage pulse in this case had an amplitude of 440V, and the measured cavity coupling coefficient was  $2.5 \pm 0.5\%$ . The theoretical value corresponding to this voltage was  $3.7\%$ , assuming a uniform modulating field in the crystal. The difference is most likely attributable to the field distortion produced by the presence of the orthogonal set of electrodes.

The stability of the mode-locking is unaffected by the coupling. This is true even when the coupling is increased to the point of nearly extinguishing laser oscillation (Figure 3). The upper trace in Figure 3 is the mode-locked pulse train observed at  $M_6$ , while the lower trace is the coupled output. The coupling voltage was applied during the period from the beginning of the trace to the second division mark from the left. During this period the laser pulse train is being quenched. After the voltage is removed the laser recovers with a time constant of approximately  $5 \mu\text{sec}$ . With coupling factors of less than  $5\%$ , recovery is practically complete within a single resonator transit time as is evident in Figure 2.

Application of this technique to pulse code modulation is evident from Figure 4, which shows the coupling of a single pulse and a triplet of

Figure 3. Laser output under over-coupled conditions.  
Horizontal scale -  $1 \mu\text{s}/\text{div}$ .  
Dumping pulse of  $2 \mu\text{s}$  duration.

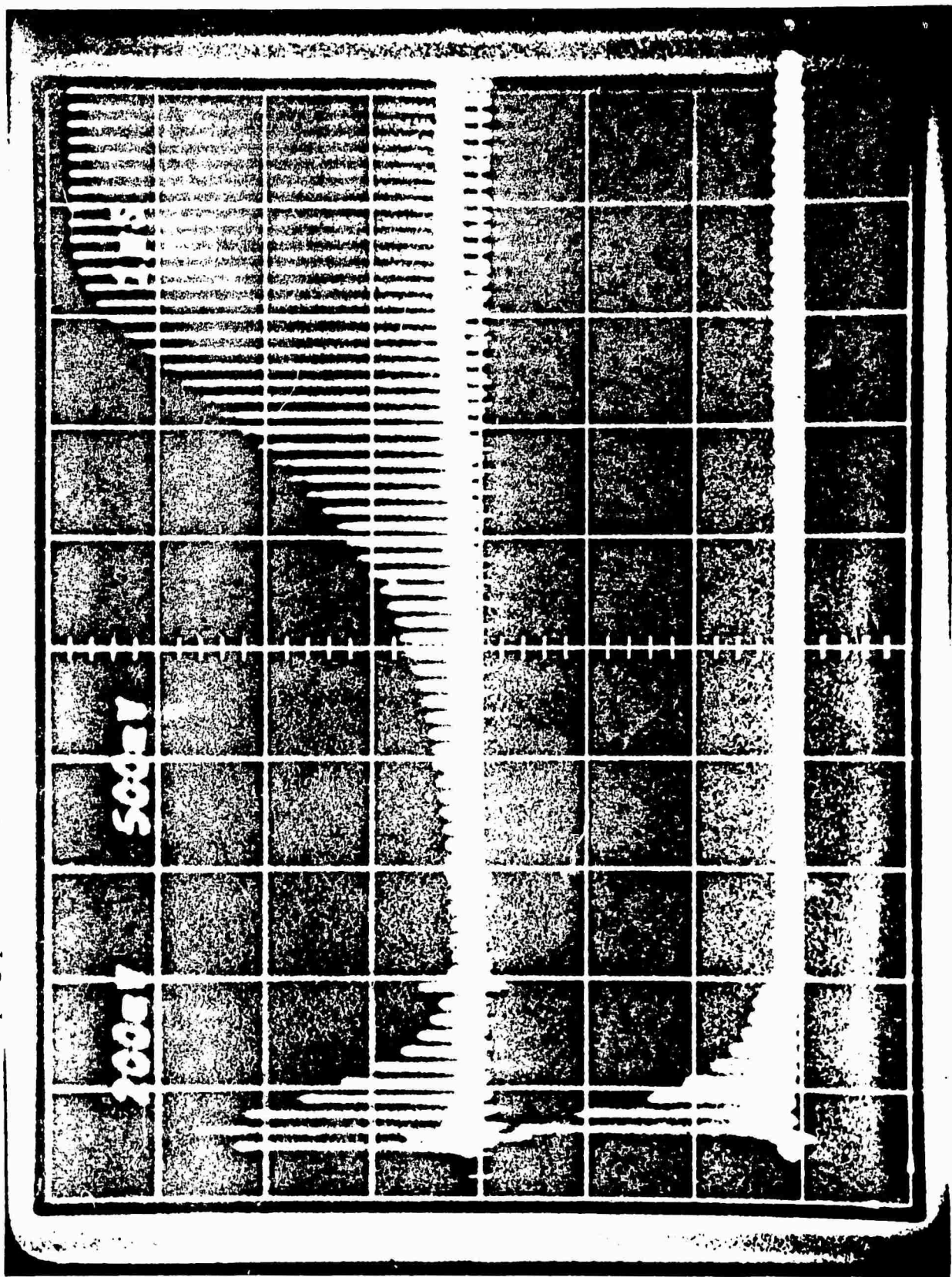

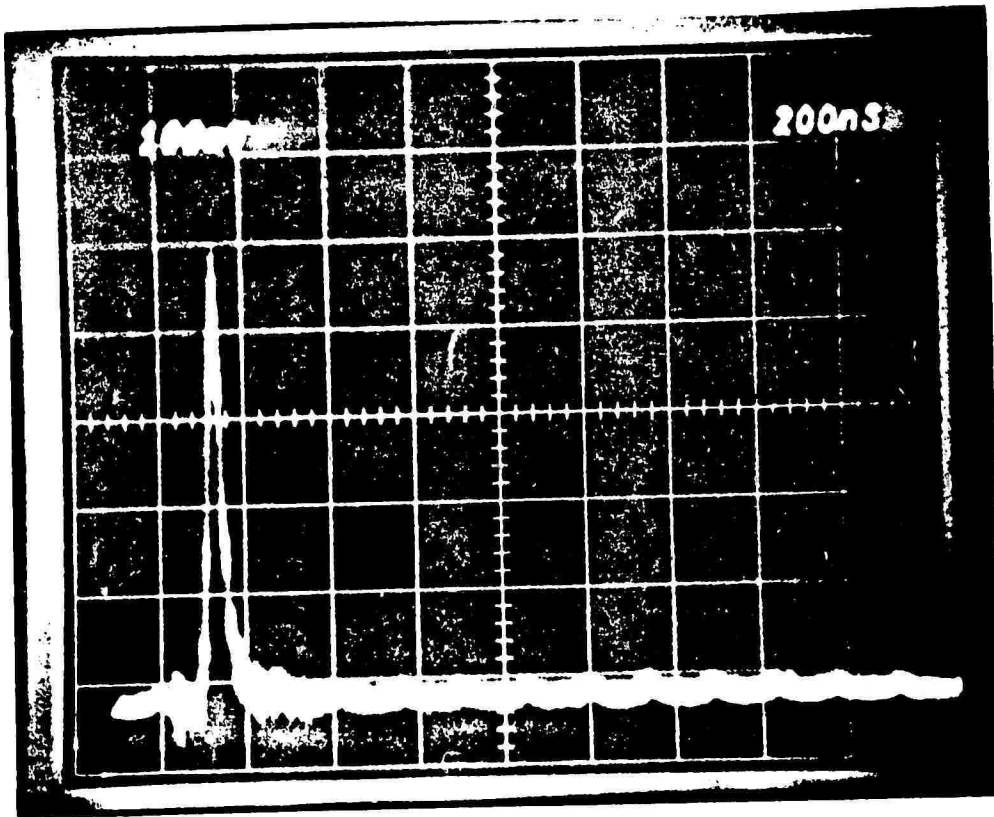
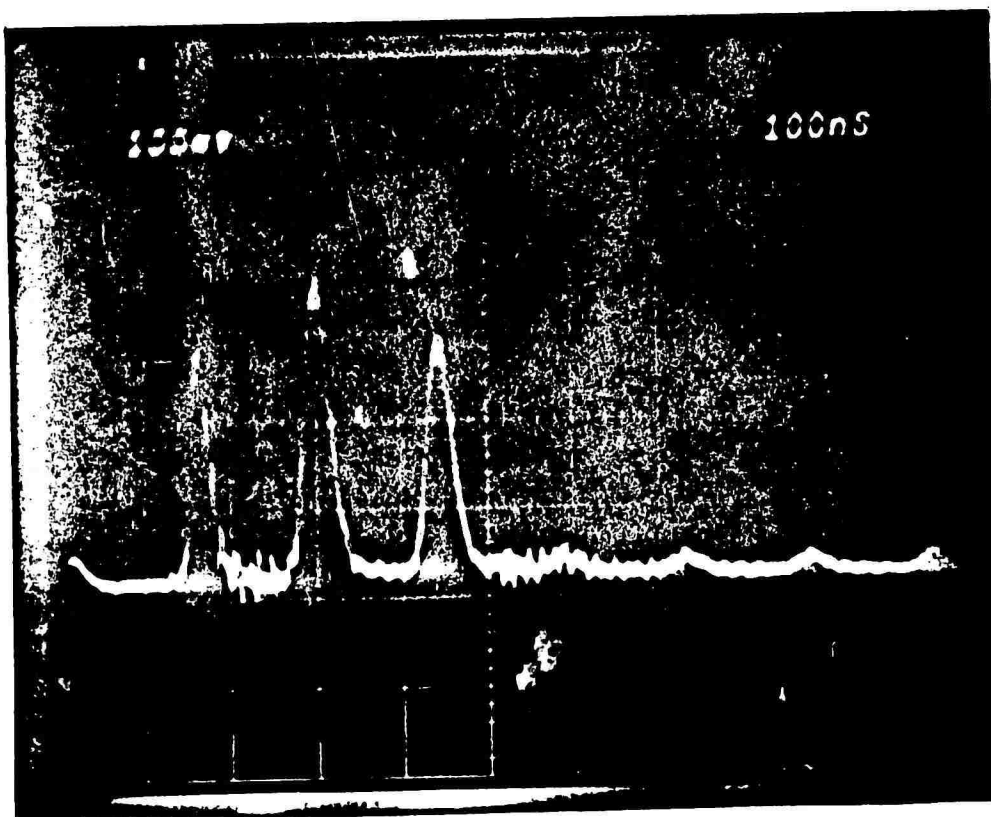

Figure 4. Coupled pulses.  
 Upper trace - horizontal scale - 100 ns/div. 100 ns dumping pulse.  
 Lower trace - horizontal scale - 200 ns/div. 400 ns dumping pulse.





pulses respectively. The ratio of the peak power of the coupled pulses to that of the pulses leaking from the cavity with no applied coupling signal is greater than 30:1. This demonstrates that this technique can be used to PCM or PAM the laser output by coding the voltage pulses applied to the coupling electrodes.

## REFERENCES

1. T. J. Bridges and P. K. Cheo, Appl. Phys. Letters 14, 262 (1969).
2. M. M. Mann, R. G. Eguchi, W. B. Lacina, M. L. Bhaumik and W. H. Steier, Appl. Phys. Letters 17, 393 (1970).