

AD716864

AMRL-TR-70-73



**FEASIBILITY INVESTIGATIONS OF ELECTROSTATIC
PRECIPITATION FOR THE REMOVAL OF GASEOUS TRACE
CONTAMINANTS FROM MANNED CABIN ATMOSPHERES**

GEORGE J. DOYLE

ROBERT WEAVER

QUENTIN McKENNA

STANFORD RESEARCH INSTITUTE

OCTOBER 1970

This document has been approved for public
release and sale; its distribution is unlimited.

Best Available Copy

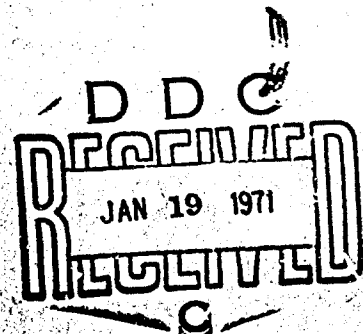

**AEROSPACE MEDICAL RESEARCH LABORATORY
AEROSPACE MEDICAL DIVISION
AIR FORCE SYSTEMS COMMAND
WRIGHT-PATTERSON AIR FORCE BASE, OHIO**

Reproduced by
**NATIONAL TECHNICAL
INFORMATION SERVICE**
Springfield, Va. 22151

NOTICES

When US Government drawings, specifications, or other data are used for any purpose other than a definitely related Government procurement operation, the Government thereby incurs no responsibility nor any obligation whatsoever, and the fact that the Government may have formulated, furnished, or in any way supplied the said drawings, specifications, or other data, is not to be regarded by implication or otherwise, as in any manner licensing the holder or any other person or corporation, or conveying any rights or permission to manufacture, use, or sell any patented invention that may in any way be related thereto.

Federal Government agencies and their contractors registered with Defense Documentation Center (DDC) should direct requests for copies of this report to:

DDC
Cameron Station
Alexandria, Virginia 22314

Non-DDC users may purchase copies of this report from:

Chief, Storage and Dissemination Section
Clearinghouse for Federal Scientific & Technical Information (CFSTI)
Sills Building
5285 Port Royal Road
Springfield, Virginia 22151

Organizations and individuals receiving announcements or reports via the Aerospace Medical Research Laboratory automatic mailing lists should submit the addressograph plate stamp on the report envelope or refer to the code number when corresponding about change of address or cancellation.

Do not return this copy. Retain or destroy.

100 - December 1970 - CO305 - 16-77-291

ACCESSION TO		
CFSTI	WRITE SECTION	<input checked="" type="checkbox"/>
DDC	DDC SECTION	<input type="checkbox"/>
UNANNOUNCED		<input type="checkbox"/>
JUSTIFICATION		
BY		
DISTRIBUTION/AVAILABILITY CODES		
DIST.	AVAIL.	and/or SPECIAL

Security Classification

DOCUMENT CONTROL DATA - R & D

(Security classification of title, body of abstract and indexing annotation must be entered when the overall report is classified)

1. ORIGINATING ACTIVITY (Corporate author) Stanford Research Institute 19722 Jamboree Boulevard Irvine, California 92664		2a. REPORT SECURITY CLASSIFICATION UNCLASSIFIED	
		2b. GROUP N/A	
3. REPORT TITLE FEASIBILITY INVESTIGATIONS OF ELECTROSTATIC PRECIPITATION FOR THE REMOVAL OF GASEOUS TRACE CONTAMINANTS FROM MANNED CABIN ATMOSPHERES			
4. DESCRIPTIVE NOTES (Type of report and inclusive dates) Final Report 1 October 1968 - 15 April 1970			
5. AUTHOR(S) (First name, middle initial, last name) George J. Doyle Robert Weaver Quentin McKenna			
6. REPORT DATE October 1970		7a. TOTAL NO. OF PAGES 29	7b. NO. OF REFS 3
8a. CONTRACT OR GRANT NO. F33165-69-C-1047		9a. ORIGINATOR'S REPORT NUMBER(S) Stanford Research Institute Project No. PSU-7522	
b. PROJECT NO. 6373		9b. OTHER REPORT NO(S) (Any other numbers that may be assigned this report) AMRL-TR-70-73	
c. Task No. 637302			
d.			
10. DISTRIBUTION STATEMENT This document has been approved for public release and sale; its distribution is unlimited.			
11. SUPPLEMENTARY NOTES This research is a continuation of that reported in AMRL-TR-68-111.		12. SPONSORING MILITARY ACTIVITY Aerospace Medical Research Laboratory Aerospace Medical Division Air Force Systems Command	
13. ABSTRACT Wright-Patterson Air Force Base, Ohio The feasibility of electrostatic precipitation of clustered lithium ions for removal of gaseous trace contaminants from atmospheres could not be demonstrated under the constraints imposed on the experimental work. The major difficulty was that the thermionic source caused oxidation of the contaminants (acetone, methanol, and propane at 1-25 ppm concentration). The source was designed to minimize thermal effects such as oxidation and consume about the minimum practical heating power density to produce the necessary ion current in atmospheres near 760 torr pressures. Even at trace concentrations of oxygen in nitrogen, the oxidation rates were sufficient to obscure any possible precipitation effects. Further work should be done using a cooler ion source or, preferably, a source effectively isolated from the atmosphere to be purified. Development of such a source seems completely feasible on the basis of present technology.			

DD FORM 1473
1 NOV 65

Security Classification

14. KEY WORDS	LINK A		LINK B		LINK C	
	ROLE	WT	ROLE	WT	ROLE	WT
<p>Experimental application of:</p> <p>Clustering about lithium ions: rates, equilibria</p> <p>Ion-molecule interactions</p> <p>Ionic processes</p> <p>To problems of:</p> <p>Purification of space-cabin atmospheres</p> <p>Removal of pollutants from air</p> <p>Air pollution</p> <p>Gas purification</p> <p>Air purification</p> <p>Pollution abatement</p> <p>Atmosphere purification</p>						

SUMMARY

The ion source was improved to gain the longer service life necessary for obtaining experimental data at a high confidence level. Improvements consisted of finding a better alloy for the heater wires of the ion source grid (8% tungsten in platinum alloy, Sigmund Cohn Corporation) and refining the method of mounting and tensioning these wires. These improvements increased service life from the original two to four hours to approximately twelve hours at 1000 C. During the course of the experimental work, continual changes were made in the apparatus to reduce errors. Gas chromatography was used to supplement the flame ionization detector in monitoring influent and effluent gases, particularly for carbon dioxide and the introduced contaminants.

Three contaminants--acetone, methanol, and propane--were studied over the concentration range of 1 to 24 ppm (v/v). The first significant experiments with acetone in air showed that acetone was being completely oxidized to carbon dioxide and that this effect completely overshadowed any possible cluster precipitation effect. To suppress oxidation, all further work was done in a nitrogen carrier with precautions to suppress diffusion of atmosphere oxygen through the seals of the purification cell. However, even at the resultant trace oxygen concentration, oxidation overshadowed any effects due to lithium ion current. This was also true of the other two contaminants, methanol and propane. Further work on this approach should be done using an ion source especially designed to avoid the presence of hot surfaces within the purification cell.

Since clustering is a well-established classical phenomenon, first observed by its interference with older (before about 1930) determinations of ionic mobility, and since the energies of cluster formation have been shown to be in the tens of kilocalories range (Doyle and Caldwell, 1966), there is little doubt that clustering can be used to remove trace polar impurities from gases, at least on a laboratory scale. However, this work has shown that this cannot be experimentally demonstrated using thermionic sources in contact with a test atmosphere containing oxygen down to trace concentrations. The source used in this work was designed with extreme precautions to minimize such thermal effects as oxidation.

FOREWORD

This research was performed at the Southern California laboratories of Stanford Research Institute, Irvine, California, under Contract F33165-69-C-1047 with Aerospace Medical Research Laboratory. The study was conducted in support of Project No. 6373, "Equipment for Life Support in Aerospace," Task No. 637302, "Respiratory Support Equipment." The research was monitored by Mr. William H. Toliver, Sr., Chemical Hazards Branch, Toxic Hazards Division, Aerospace Medical Research Laboratory, Wright-Patterson Air Force Base, Ohio. The period of performance by Stanford Research Institute was from 1 October 1968 to 15 April 1970.

This study was conducted under the specific direction of Dr. George J. Doyle, with experimental contributions by Robert Weaver and Quentin McKenna. General supervision was given by Dr. Fritz Kalhammer. The research was performed under the administrative direction of Dr. R. D. Englert, Executive Director, SRI-Irvine. The authors wish to express their appreciation for the encouragement and assistance provided by Mr. W. H. Toliver, Sr.

This technical report has been reviewed and is approved.

C. H. KRATOCHVIL, Colonel, USAF, MC
Commander
Aerospace Medical Research Laboratory

TABLE OF CONTENTS

Section Number		Page Number
I	INTRODUCTION.	1
II	EXPERIMENTAL.	4
	Improvement of the Ion Source	4
	Gas-Feed System	5
	Electrical System	7
	Typical Procedure	7
	Special Equipment: Gas Chromatographs.	11
III	RESULTS	12
	Acetone	12
	Methanol.	20
	Propane	22
	Summary of Experimental Results	22
IV	DISCUSSION, CONCLUSIONS, AND RECOMMENDATIONS.	27
	Discussion.	27
	Conclusions	27
	Recommendations	28
	REFERENCES.	29

LIST OF ILLUSTRATIONS

		Page Number
Figure 1	Cross-Section of One Element of a Ten-Element Cell, Air Purification Cell	3
Figure 2	Diagram for Gas Flow, Air Purification Cell	6
Figure 3	Wiring Diagram for Power Supplies, Air Purification Cell.	8
Figure 4	Experimental Results with Acetone in Air, Air Purification Cell, Run 102.	14
Figure 5	Experimental Results with Acetone in Nitrogen, Air Purification Cell, Run 103.	16
Figure 6	Experimental Results with Acetone in Nitrogen and Minimum Oxygen, Air Purification Cell, Run 104. . .	18
Figure 7	Experimental Results with Methanol in Nitrogen and Minimum Oxygen, Air Purification Cell, Run 106.	21
Figure 8	Experimental Results with Propane in Nitrogen and Minimum Oxygen, Air Purification Cell, Run 105.	23
Figure 9	Idealized Behavior of Effluent Concentration, Air Purification Cell	24
Figure 10	Detail of Idealized Behavior of FID Current After Initial Rapid Changes Have Occurred, Air Purification Cell.	25

SECTION I

INTRODUCTION

A lightweight air purification unit of low energy consumption and long service life is needed for long duration space missions. New techniques for atmosphere purification would relieve the design engineer from constraints imposed by the present state of the art. One possible technique is extension of electrostatic precipitation to particles of molecular size. The study described herein is part of a feasibility study undertaken as a preliminary step to a possible development program, and is a continuation of the research reported in AMRL-TR-68-111 (Doyle, 1968).

The first phase of this inquiry was a theoretical study to explore means for implementing the concept (Doyle and Caldwell, 1966). In that study, the consequences of injecting ions into a contaminated atmosphere and collecting the resultant charged species were considered on the basis of present knowledge. It was concluded that exploration of clustering on injected ions offered the most promise, at least for an initial feasibility study.

Further consideration led to the selection of a small positive ion for injection, such as H^+ or Li^+ , because binding of polar contaminants into a cluster would be stronger, due to the high field provided. Li^+ was chosen because its low electron affinity reduced the probability of chemical reaction, such as charge transfer, which would complicate interpretation of experimental results. Because well-established techniques were available for thermionically generating Li^+ , this course was selected for development of the ion source.

The theoretical study (Doyle and Caldwell, 1966) showed that small polar molecules would be most strongly bonded to the clustering ion. Therefore, molecules such as water, carbon dioxide, ketones, alcohols, and so forth would be the most susceptible to removal by clustering. Water and carbon dioxide are interfering substances in this context. A matrix of dry gas (air or, less preferably, nitrogen) free from carbon dioxide was selected to minimize interference by water or carbon dioxide. Compounds selected for study were straight chain ketones, alcohols, and hydrocarbons. The most favorable member of each of these three homologous series was chosen for initial study--acetone, methyl alcohol, and propane, in that order. Other members of the series were to be investigated only if encouraging results were obtained with the representative compounds.

The design of the purification cell was given in detail in a previous report (Doyle, 1968) along with initial work with the ion source and removal of acetone. Emitter area per unit cross-sectional area of the cell was as small as practicable to reduce heating power dissipated in the cell. Electrode spacing was as small as possible consistent with the necessity for barriers to back diffusion from the collecting electrodes. Small spacing is desirable because it reduces the required collecting field; this, in turn, minimizes the extent to which the effective temperature of the clusters is increased above the temperature of the ambient gas.

These criteria resulted in a large flat cell of 1000 cm² cross-sectional area, 100 cm² of which consisted of collecting electrode separated from the source electrodes by a few centimeters. The collecting electrodes are at the bottom of ten slots that define the diffusion barriers. A cross-section of a segment of this cell is shown in Figure 1. The source electrodes are in the form of ten lengths of spring-tensioned, 76- μ m-diameter (40-gauge) wires coated with powdered (less than 20- μ m diameter) β -eucryptite, and capable of carrying sufficient current to heat them to 1000 C.

During the preliminary work with acetone (Doyle, 1968) the source grid was fabricated from a nickel-chromium alloy (Tophet A). This alloy proved to be unsuitable because the wires were subject to pitting corrosion and severe high temperature creep; a short service life was the result.

In spite of difficulties with this short-lived source, some work was performed with acetone that indicated a removal efficiency of around 20% (Doyle, 1968). However, these results were obtained under constraints imposed by the short life of the ion source and it was impossible to confirm this indication with any degree of confidence. Particularly lacking were data on background level of impurities in the cell and blank runs (no acetone or no ion current). The work reported here is intended to confirm the preliminary results with acetone under more auspicious experimental conditions and to obtain results with other contaminants from the three series of homologous compounds chosen.

Figure 1

CROSS-SECTION OF ONE ELEMENT OF A TEN-ELEMENT CELL,
AIR PURIFICATION CELL

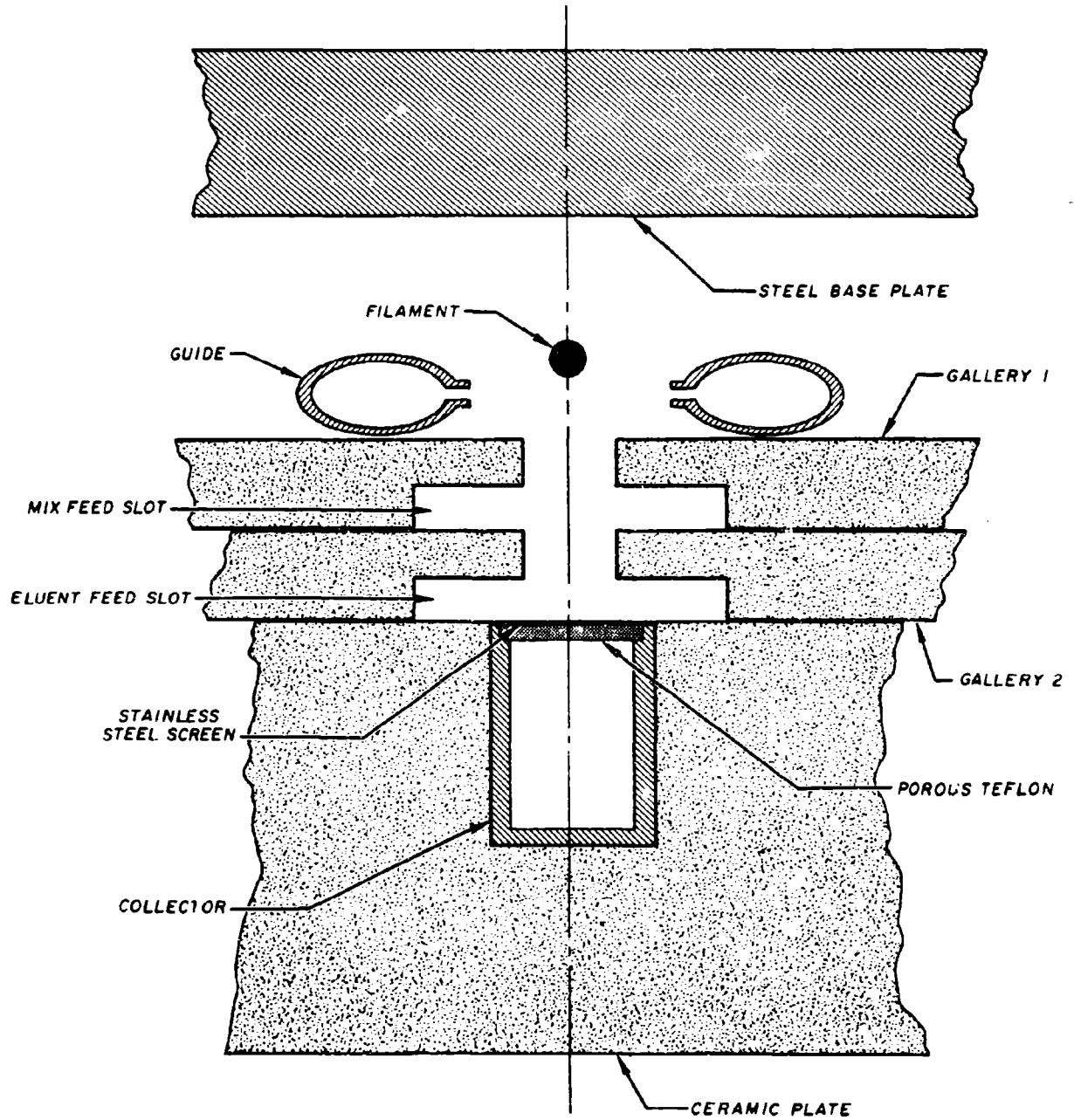

SECTION II

EXPERIMENTAL

Since the last report (Doyle, 1968) there have been changes in the flow control system, electrical connections, and in apparatus auxiliary to the purification cell. These changes resulted in the arrangement used in the experiments discussed here. Some additional refinements were added during the final series of experiments with acetone, primarily to exclude oxygen from the cell.

The cross-section through one of the ten electrode assemblies of the cell (shown in Figure 1) is perpendicular to the filaments. The function of the steel base, the filament, guide, Galleries 1 and 2, and their respective gas-feed slots for "mix" and "eluent" gases, and the collector have been discussed (Doyle, 1968).

The auxiliary equipment required to perform experiments with the cell previously described (Doyle, 1968) has since been augmented and improved to achieve better control over cell inputs and to obtain more information about cell influent and effluent gas composition. Concentration of organic constituents in the effluent gas sweeping the ion collection surfaces (the "rich-out" gas) was always monitored by use of a flame-ionization detector. However, this necessary monitoring system was not sufficient to provide differentiation between model contaminants and organic constituents accidentally present in the gas stream. Furthermore, this type of detector does not respond to carbon dioxide. Hence, gas chromatography was employed as an adjunct to the flame analysis. This equipment and a typical procedure are described briefly below.

IMPROVEMENT OF THE ION SOURCE

Improvement consisted of choosing a better support material for the β -eucryptite and refining the method of mounting the support wires in the ion source grid. This led to a longer lived source and allowed more uniform and controllable heating of the ion source wires.

Several platinum alloys (Sigmund Cohn Corporation) in the form of 76- μ m-diameter wires were subjected to life tests in a mock-up of the cell. All were superior to the nickel-chromium alloy first used. An alloy of platinum with 8% tungsten was superior to the other platinum alloys, primarily because of its mechanical strength at the elevated temperature. This alloy was used in the experiments described here.

The improved suspension system is a modification of the previous system (Doyle, 1968). It consists of 29.3-cm ($\pm 1\%$) lengths of filament wire supported at one end with a Teflon-insulated, stand-off terminal and, at the other end, by a colinear coiled spring that is also supported by a stand-off terminal. To avoid destroying the elasticity of the springs (by Joule heating), the current to each grid wire is by-passed around its tensioning spring by means of an annealed 0.006-inch-diameter gold wire loop. The springs were fabricated by winding $40 \pm \frac{1}{4}$ turns of No. 34 Tophet A wire on a 5.6-mm ($\frac{7}{32}$ -inch) diameter mandrel. The length of the closed springs is 0.7 cm; the spring constant is 1.4 cm/gram at loads between 0.5 and 1.5 grams. The cold filament wires were pretensioned to 1.5 grams, about twice the tension required to prevent sagging. On heating to operating temperature, the filament extended reversibly by 0.4 cm, upon which was superimposed a long term, high temperature creep. The reversible extension caused a reduction in tension from 1.5 to 1.2 grams, allowing a margin of 1.1 cm to accommodate the creep. As long as temperatures were maintained at less than 1100 C, long filament life was assured; for example, at 900 C the life was found to be in excess of 12 hours. If temperatures of 1100 C were continuously employed, accelerated creep limited filament life to 2 hours. In none of the runs employing this new spring arrangement was filament failure encountered, even though some runs consumed as much as 16 hours of operating time at temperatures between 900 and 1000 C.

GAS-FEED SYSTEM

As shown in Figure 2, the gas flow system allows the desired gas or gas mixture to be fed to the cell at the appropriate inlet port and at a known and, where necessary, monitored rate. The air tank - regulator system supplied clean, dry air (zero-gas) to the air-hydrogen flame of the ionization detector, to the eluent feed slot of Gallery 2, and to the mixing system used to dilute the sample gas to the required concentration. The sample gas--for example, acetone in Figure 2--was purchased with a certified concentration and analysis, so that only dilution with dry air was required prior to introduction into the cell. The hydrogen for the flame ionization detector also was purchased with certified purity, especially with regard to hydrocarbon impurities, which were below 2 ppm (parts per million).

A valving arrangement allowed gas from any of the gas lines to be fed into the flame-ionization detector for analysis (Figure 2). The positive internal pressure of the cell (less than 4 torr, gauge) must be held constant irrespective of which gas stream was being monitored by the FID (flame ionization detector) in order that the gas flows do not vary with sampling mode. To facilitate

Figure 2

DIAGRAM FOR GAS FLOW, AIR PURIFICATION CELL

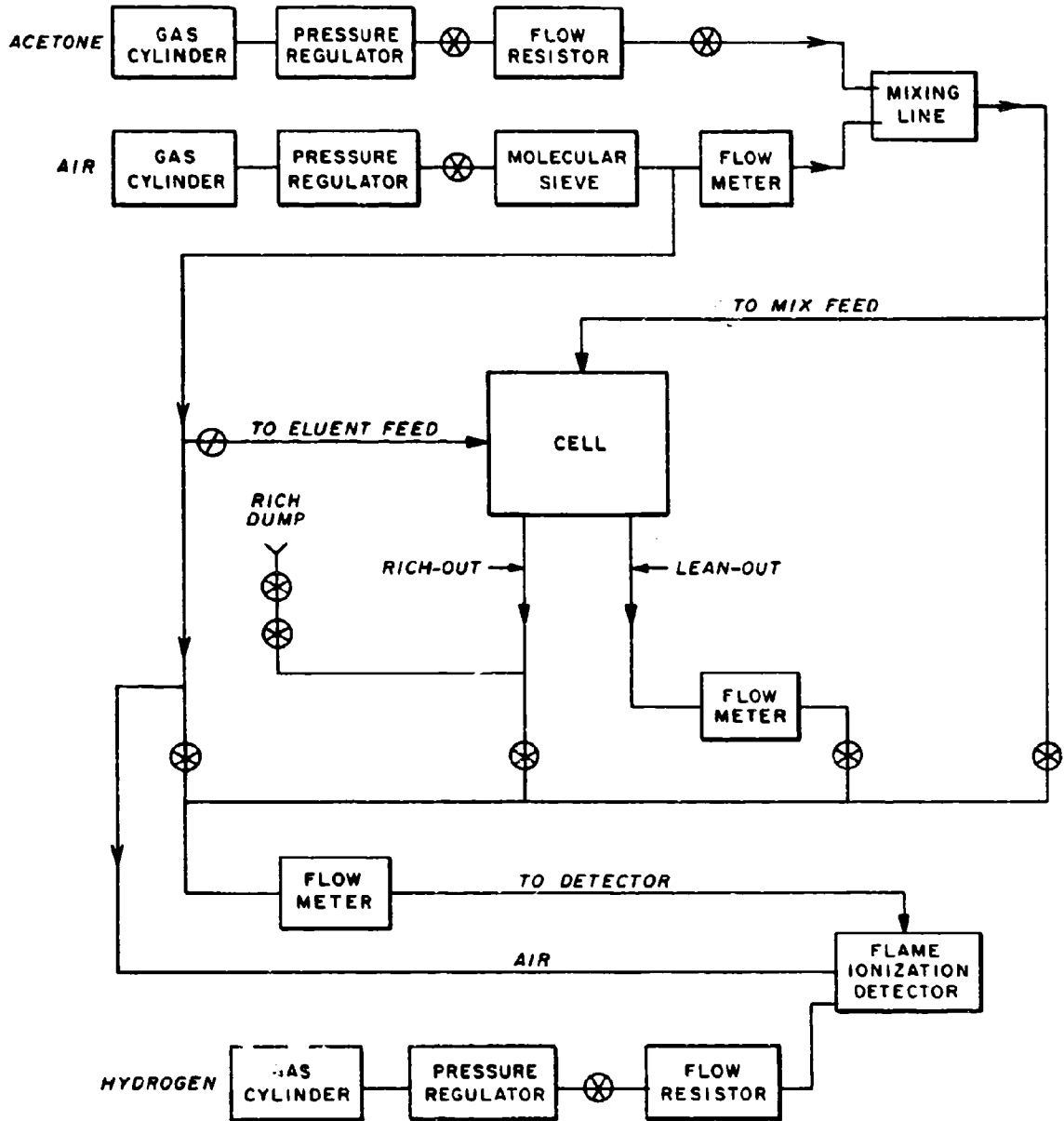

pressure constancy, a valve-switching arrangement, also shown in Figure 2, allows the rich-out gas to flow continuously at constant pressure drop. There are two valves in the dump line--one a shut-off valve, the other a throttling valve adjusted so that the rich-out flow remains constant when flowing either to the FID (shut-off closed) or to the dump exhaust (shut-off opened). Not shown in Figure 2 are septum-type gas-sampling ports in each line. These ports allowed extraction of samples for gas chromatographic analyses.

ELECTRICAL SYSTEM

Electrical auxiliaries are shown in Figure 3. Four adjustable regulated power supplies were used. These power supplies included two high-current power supplies of the automatic cross-over type in series, to heat the ion source, biased to the potential found necessary to facilitate drawing ion current from the source (this bias is limited by the insulation of the power supplies to ± 500 volts). As shown in Figure 3, the base plate, accessible to the operator, was established at chassis ground and at water-pipe ground and became the reference point for all potentials. For purposes of safety, the collector was connected to a power supply through a 6×10^6 ohm current-limiting resistor. Inasmuch as the maximum current was 10^{-5} amp, this resistor caused a voltage loss of no more than 60 volts. The power supply covered the range from zero to minus 3 kv.

The guide and ion source were polarized by a second circuit, also shown in Figure 3. Again, current-limiting series resistors were employed as shown. The filaments were at a positive potential with respect to the base plate to get useful ion current. The two 1500-ohm resistors across the heater supplies allowed application of this potential to the electrical center of the filament wires.

The polarities of the polarizing potentials shown were the initial ones. Investigation preliminary to experimental work showed that a greater ion current could be drawn from the filaments with the guide electrode floating, presumably at some positive potential established by its capturing a small percentage of the ion current.

TYPICAL PROCEDURE

In a typical run the objective was to establish a steady state of known characteristics from which deviations due to ion-clustering with consequent enrichment of contaminants could be discerned. Although the means of achieving this objective varied somewhat in different runs, the procedure was essentially as follows:

Figure 3

WIRING DIAGRAM FOR POWER SUPPLIES, AIR PURIFICATION CELL

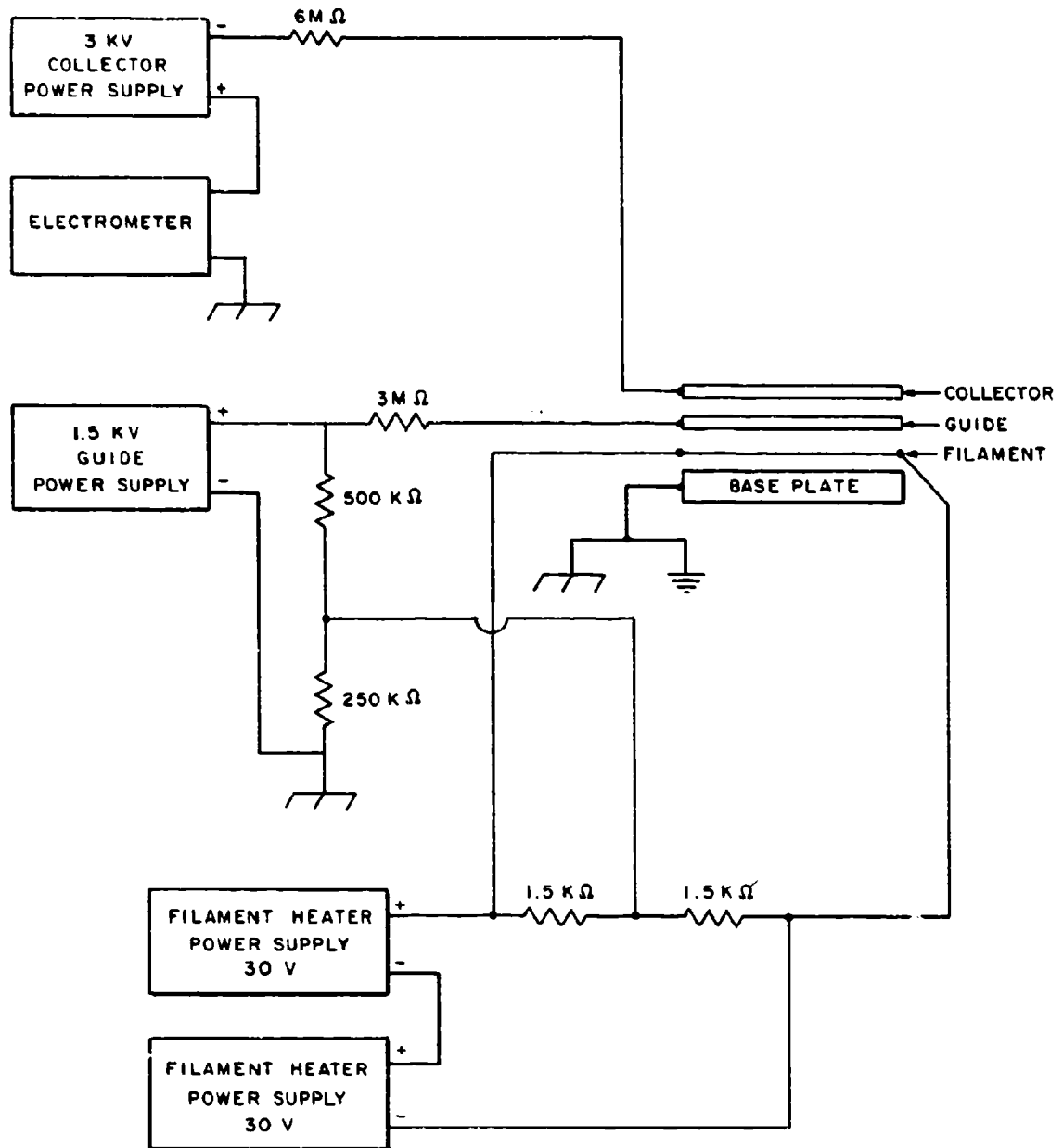

Cell preparation.

1. After a run, the cell was disassembled and the old filaments removed.
2. New filaments were installed and coated with β -eucryptite in a collodion - ethyl acetate suspension.
3. Filaments were heated to evaporate solvents and to thermally decompose and oxidize organic binder. At a manually controlled constant rate of increase, the temperature attained was 600 C, with five minutes being required for the entire baking process.
4. The cell was then reassembled and all external connections made. In addition to the connections shown in Figures 2 and 3, connections for circulating cooling water through the backing plate channels and cooling air under the collection electrode support also were made.

Cell operation. The assembled cell requires approximately two days of flushing with clean gases to remove traces of adsorbed impurities collected by exposure of the disassembled cell to the laboratory atmosphere. To remove these impurities, and thus establish a stable initial condition, a standard sequence was followed:

1. The FID was started and ionization current, as measured with an electrometer, was monitored with a strip-chart potentiometric recorder. This record, taken continuously throughout the run, and annotated during the run formed the principal record of the run's history. As previously described, the switching system allowed all cell gases to be monitored. The exhaust gas from the collector channel (rich-out) was the stream usually monitored, with other gas streams being monitored intermittently if desired.
2. The cell was purged with clean air (air not yet admixed with the model contaminant) and purging was continued until both effluent streams from the cell (lean-out and rich-out) were as clean as the incoming air, as evidenced by the FID. Depending on the initial cleanliness of the cell, the time required for cleaning varied from 4 hours to as much as 4 days in one instance. In many runs, the filaments were heated to less than 600 C and neither the cooling water nor cooling air was turned on, thus causing the cell temperature to rise and to accelerate the cleaning process.

3. After obtaining a clean cell, the gas mixture was introduced to the cell and concentration of the contaminant was monitored. When the gas streams from the collectors and the guides (rich and lean) were equal in concentration to the incoming mixture, the run was ready to start. The time required for the concentrations to become equal was not less than 4 hours. Time to this steady state depends on flow rate into the cell (flow rates of inlet gas of 120 ml/min were usual but, in some cases, flow rates of 20 and 300 ml/min were used). It also depends on the ratio of flow rates of gases between the lean and rich mixtures. Occasionally, all of the effluent gases were diverted through the collector channel or the guide to hasten the attainment of equilibrium in the one at the expense of the other; this expedient was usually used to flush the collector channels. Flushing of these channels was slow, probably because there was only one exit port per channel, and that was at the end.
4. After attaining essentially equal contaminant concentrations in influent and effluent gases, the filaments were heated to a temperature which gave sufficient emission of Li^+ ions. This was determined by applying the polarizing potentials and measuring the ion current with an electrometer. Filament current and voltage were increased slowly* until the ion current reached 5 μamp and then were maintained at the determined level; the potentials to the collector and guide were turned off.
5. While the filaments were hot but no ion current was being collected, the effects of the heated filaments could be observed--in effect, an oxidation blank. This blank was continued until trends in concentration were evident. The potentials to the guide and collectors then were applied continuously so as to maintain a Li^+ ion current between 2 and 10 μamp .† Small increases in filament current were made, if necessary to maintain this current level.‡

* Usually over a period of five to ten minutes to minimize pressure changes due to gas heating; ion current was monitored for a few minutes near the end of this period.

† The usual polarizing voltage was 2800 volts on the collection electrodes. Initially the guide was set at +1500 volts, but subsequently it was left floating with no applied potential, for this was found to yield the highest current.

‡ Because the power supplies for the collector and guide were already at or near the maximum available from the supply, it often became necessary to increase the filament temperature to maintain Li^+ currents.

6. The effects of the ion current were monitored until analysis data for all gas streams had been accumulated; the polarizing potentials were then turned off. Monitoring of the FID current was continued for a relatively short period before terminating the experiment. On termination, filament temperature was decreased slowly to avoid negative pressures in the cell. After the cell had cooled, all flows were shut off and the cell was dismantled in preparation for the next run.

SPECIAL EQUIPMENT: GAS CHROMATOGRAPHS

In the course of the experimental program, it became evident that additional information was needed on the composition of the effluent gases. Specifically, the concentration of carbon dioxide became extremely important to the interpretation of results.

Determination of carbon dioxide with the required high sensitivity was accomplished. The carbon dioxide was separated chromatographically from the other constituents of the gas sample and converted on a nickel catalyst to methane, according to the Sabatier reaction

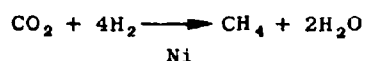

The methane generated in this reaction was detected with high sensitivity by the FID of the chromatograph. Because conversion of carbon dioxide to methane remained essentially complete over extended periods, occasional calibration of the apparatus with known concentrations of carbon dioxide proved sufficient.

Because of the nonspecific response of the monitoring FID, organic impurities were sensed along with the intentionally added trace impurity; thus, the FID could be regarded only as a total organics detector. To provide more specific information on the fate of the contaminants, two gas chromatographs equipped with FIDs were used in the later runs to monitor model and accidental contaminants in cell influents and effluents. These supplemental analyses permitted a more detailed interpretation of results than was possible in previous experimental work (Doyle, 1968).

SECTION III

RESULTS

Within the three homologous series that were to be studied, acetone, methanol, and propane are the molecules judged to be most susceptible to clustering. Because acetone is the most likely to cluster (Doyle and Caldwell, 1966; Doyle, 1968), the greatest effort was expended on it to confirm earlier indications and to refine techniques.

ACETONE

To meet the objective for a run, as specified in Section II, a number of preliminary "debugging" experiments were run. In these, the effects of filament temperature, mixing systems, plumbing, and other apparatus and procedural aspects were examined, and deficiencies corrected as necessary. This included repair of the ceramic mounting plate for the collector electrodes which had cracked due to thermal stress during early studies. The plate was repaired by casting a silicone rubber (Dow Corning, Sylgard 186 Resin)* over the external surface of the plate. Danger of additional cracking was reduced by redesigning the base of the cell so that cooling air from a blower was circulated behind the ceramic base at a rate of approximately 3 cubic meters per minute (100 cfm).

On attempting to reach a cold steady state with trace concentrations of acetone, it was discovered that the relatively high surface area of the porous stainless steel strips† located in the collector channels caused difficulties due to their high surface area, which acted as a sink for the low concentration acetone. For example, at 1 ppm acetone, more than four days were required to bring the gas from the collector to 90% of the concentration of the entering mixture. This long time constant was reduced to four hours by removing the porous stainless steel and replacing it with strips of 3.2-mm ($\frac{1}{8}$ -inch) thick porous Teflon (9 μ m pore size) pressed into the channels and overlaid with 39.4-cm⁻² strands (100 mesh), 114- μ m (4.5-mil) diameter, stainless steel screen spot-welded to the channel edges.

Other preparative steps included life tests of the new filament arrangement and refinements of the plumbing to reduce dead volume and the likelihood of leakage. The apparatus was then considered ready for acquiring significant data.

* This resin is an electronic grade elastomer intended for application where minimum impurities and out-gassing are of great importance.

† These strips are 1.6 mm ($\frac{1}{16}$ -inch) thick and extend the length of the collector channel; their purpose is to ensure uniform flow of gases through equal lengths of the collector.

In the first of the confirmatory series of experiments with acetone as the contaminant, acetone concentration was 10 ppm (v/v) in dry air; results for this Run (No. 103) are shown in Figure 4. This figure shows curves for the FID current of the cell's effluent gases and the GC analyses for carbon dioxide. Also shown are experimentally significant events, such as filament heating periods and the periods during which the polarizing voltages were applied.

Before heating the ion source filaments, the FID current showed that the effluent from the collection electrodes, the rich stream, was two-thirds the level of the influent mixture. After heating the ion source, this effluent level decreased with time to essentially zero concentration of acetone--that is, the same level obtained by sampling through the FID the incoming uncontaminated (pure) air stream. This behavior was consistent with results obtained during previous experiments with acetone at concentrations between 1 and 10 ppm.

Gas chromatographic analysis showed that on heating the ion source filaments carbon dioxide increased from 2 to 3 ppm in the cold cell to as high as 46 ppm in the lean stream and 60 ppm in the rich stream. Since complete oxidation of 10 ppm acetone would yield 30 ppm carbon dioxide, more than enough carbon dioxide was generated to account for oxidation of the influent acetone.

Also shown in Figure 4 are the periods during which polarizing potentials were applied. At that time, the resulting ion currents caused no clearly discernible changes in carbon dioxide or FID levels.*

These results were in complete agreement with the three preceding runs during which carbon dioxide was monitored after it had become apparent that acetone in the cell exhaust streams became depleted. Thus, enrichment (if present) was masked by rapid changes in acetone level caused by oxidation of acetone within the cell as soon as the ion source filaments were heated.

To avoid the oxidation problem, practical sources of lithium or other small positive ions might be nonthermionic, or if thermionic, physically removed from the atmosphere to be purified. To explore the feasibility of this approach, it was decided to carry out a series of clustering experiments under conditions where interference from contaminant oxidation would be avoided; hence, all subsequent experiments were done in the nominal absence of oxygen.

* Enrichment, that is, an increase in FID current correlatable with ion current, did not occur (see Figure 4). However, in all figures for runs, including Figures 4 and 5, there is a correlatable decrease in FID current. This phenomenon is discussed in connection with later runs.

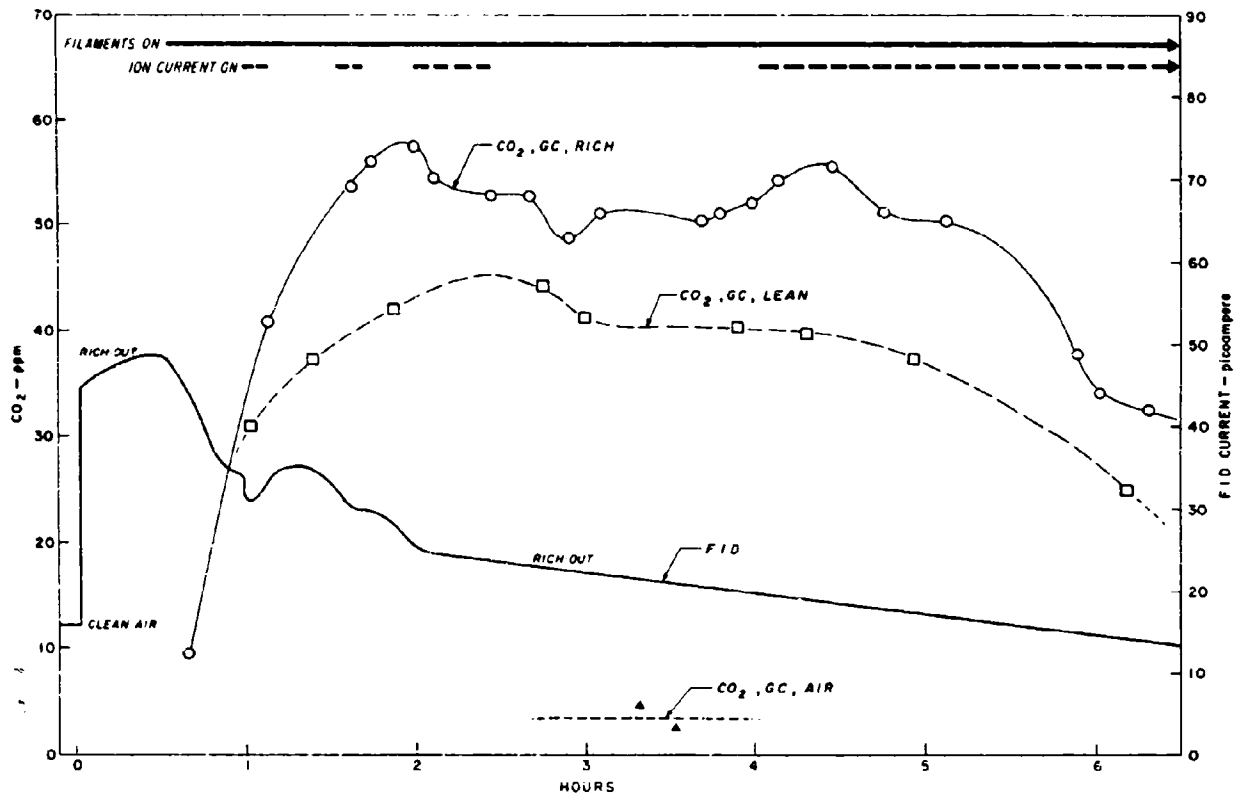

Figure 4
 EXPERIMENTAL RESULTS WITH ACETONE IN AIR,
 AIR PURIFICATION CELL, RUN 102

A preliminary experiment was carried out with 22 ppm acetone in nitrogen. After flushing the cell with this mixture for 3 hours, the ion source filaments were heated. Again, the acetone level dropped to zero and an equivalent amount of carbon dioxide was observed in the exhaust streams. This result led to an effort to reduce oxygen in the system to even lower levels. A new run was set up and it was decided to establish as firm a basis for comparison of data as possible, that is, the cell would be flushed so thoroughly that acetone concentrations in all streams would be equivalent and all probabilities of oxygen contamination would be eliminated.

To achieve these objectives, six days were required for the levels of acetone in rich and lean streams to equal the level of incoming acetone. During this time, all connections were carefully checked, and if there was any doubt that a connection was not excluding outside air, it was replaced or improved. At the end of the fourth day, the acetone in the rich stream was 80% of that of the incoming mixture. This relatively long time was due to adsorption on the surfaces of the room-temperature cell; the cell was unheated during this period of this run. On the sixth day, the acetone levels in the rich and lean streams were equal to that of the incoming mix.

During this same period, gas chromatographic analyses were employed to locate sources of oxygen, and the results indicated that the acetone tank contained detectable traces of oxygen.* However, with the techniques and detectors (thermal conductivity) available for oxygen analysis, the minimum detectable concentration was 500 ppm. Since it was considered necessary to reduce oxygen levels below 10 ppm, further oxygen analyses were abandoned and the formation of carbon dioxide, which could be detected at $\frac{1}{3}$ ppm, was chosen as the most efficient means of monitoring oxygen present in the cell.

The levels of acetone and carbon dioxide again were monitored during the seventh day. Even though the lean and rich streams were equivalent to the mix at the beginning of the day, there was a % difference at the sixth hour. These trends were repeatedly observed and were attributed to changes in adsorption associated with changes in laboratory temperature.

At the beginning of the eighth day, another study of the effects of the ion current was made. The effects are shown in Figure 5. In this run, higher levels of ion current were maintained (by raising the filament temperature) for longer periods than in the previous run. Again, the acetone level decreased to zero, and no correlation with ion current was observed at that time. Thus,

* A new tank of nitrogen-diluted acetone was ordered with a specification for low oxygen content at this time.

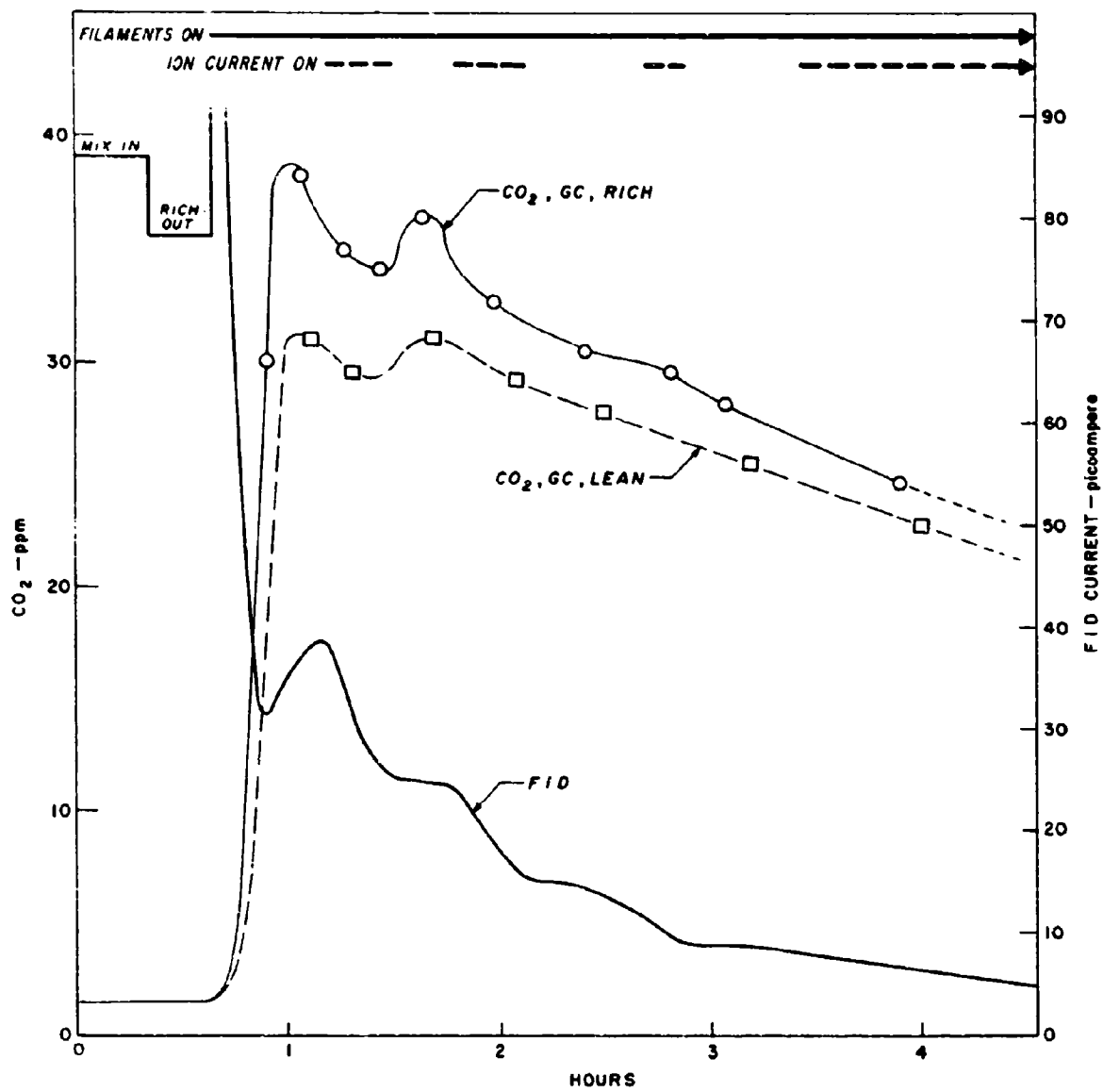

Figure 5
 EXPERIMENTAL RESULTS WITH ACETONE IN NITROGEN,
 AIR PURIFICATION CELL, RUN 103

although there were four periods of ion current, neither increase in FID current nor corresponding changes in carbon dioxide levels in the rich or lean streams was observed.

Prior to the run for which data are given in Figure 5, a gasket was placed around the cell to inhibit possible inward air diffusion. This gasket covered the edge of the cell and supplemented the O-ring seals. The annular space between the gasket and the cell was continuously flushed with helium at a rate of 100 ml/min.

In spite of the long purging of the cell to flush out traces of air, and in spite of the helium blanket, the acetone continued to be oxidized to carbon dioxide (Figure 5). These results indicated the oxygen detected in the dilute acetone to be the most suspect source of oxygen for this oxidation. The run was terminated, and preparations made for another run with the new tank of diluted acetone certified to contain little or no oxygen.

In the succeeding run, every effort was made to exclude oxygen. The new tank of certified analysis gas contained 20 ppm acetone in nitrogen with less than 4.5 ppm oxygen. This gas was used directly, without dilution; all gas lines previously used for dilution with air were either removed from the gas train or were flushed with oxygen-free nitrogen, which was prepared by passing nitrogen over freshly prepared hot copper.*

The results of the oxygen-free experiments with acetone are presented in Figure 6.† The curve representing the behavior with time of the FID current shows that steady state was reached prior to the time the filaments were heated. In the period of time preceding that displayed in Figure 6, the FID response to pure nitrogen and to the influent acetone had been monitored. Using these data, it was found that the effluent from the collectors was 3 ppm richer in organic composition than the influent acetone. An additional impurity was present in the effluent, other than acetone, but this impurity was not identified, although attempts were made to identify it (or them) using chromatography.

* According to the model of ion clustering, it was necessary to remove or exclude water from the system. However, this could not be done in these experiments without introducing further complications; also, the hypothesis being tested was independent of the presence of water. Thus, if methylene groups were oxidized by some source of oxygen, water would have been formed in any event. Further, water would not react with these groups to form carbon dioxide, which was the product gas being sensed and studied. Thus, water was not excluded from these experiments in which attempts were made to exclude oxygen.

† Run 104.

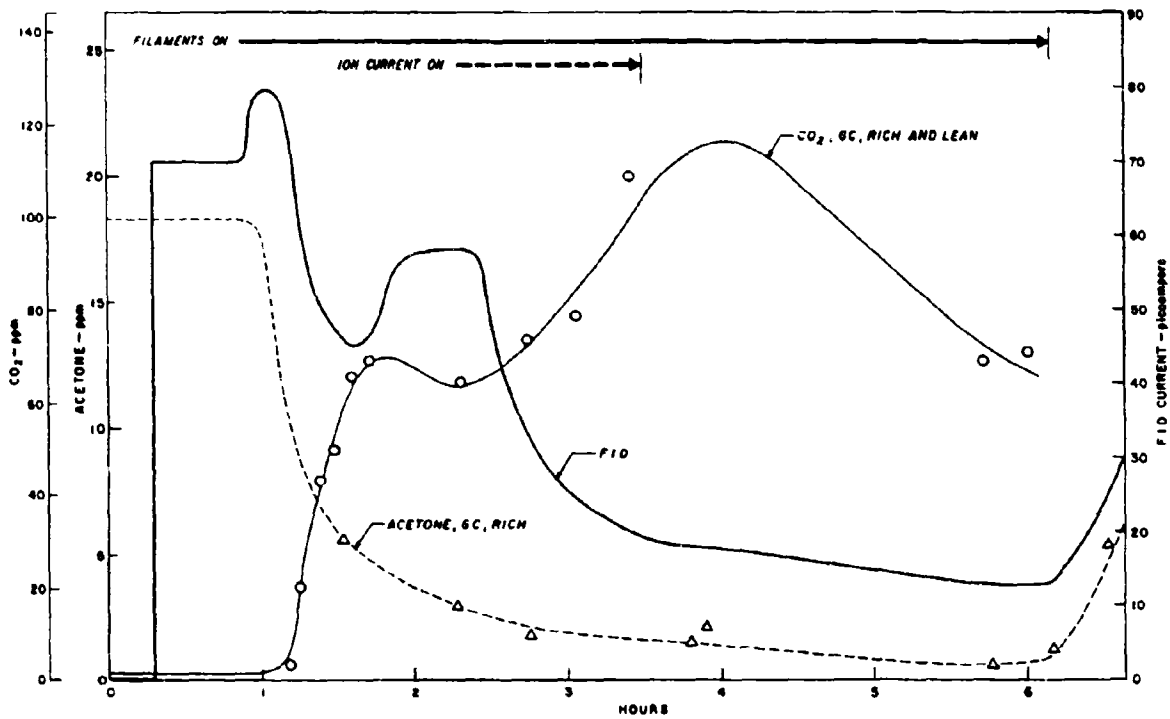

Figure 6

EXPERIMENTAL RESULTS WITH ACETONE IN NITROGEN
AND MINIMUM OXYGEN, AIR PURIFICATION CELL, RUN 104

After turning on the filaments, the level of organics in the rich stream decreased to about 3 ppm. The first hump in the FID curve (Figure 6) is due to pressure effects occurring when the filaments were heated. The cause of the second hump is not known, but presumably was caused by a further outgassing of impurities; this hump was not due to an increase in acetone as evidenced by GC results for acetone (shown in the curve for those results).

The results of the GC analysis of acetone are also shown in Figure 6. Here, a monotonic decrease in concentration was observed after turning on the filaments. These results were obtained by analyzing the rich, and sometimes the lean, stream. No significant differences were observed between the two streams at any time. By comparing the two curves, the FID data and the GC data, it is clear that the acetone level decreased essentially to zero after turning on the filaments.

The results of carbon dioxide analyses for this experiment also are presented in Figure 6. Prior to turning on the filaments, the carbon dioxide concentration was less than 2 ppm in the effluent gases. Immediately after turning on the filaments, however, the carbon dioxide concentration rose to nearly 100 ppm then decreased to about 60 ppm. The steady state level of 20 ppm acetone would have given rise to a steady state concentration of 60 ppm carbon dioxide if all the acetone were converted to carbon dioxide. Except for traces of low molecular weight compounds, not accounting for more than 2% of the acetone, no other organics were found by GC analysis. It must be emphasized, however, that the GC columns would not have found high molecular weight compounds; the approximate 3 ppm of organics indicated by the FID were not eluted from the GC columns used to analyze for carbon dioxide and acetone.

After turning off the heater current, the concentration of acetone, as monitored by either FID or GC, began to rise abruptly from the low levels reached while the filaments were heated.

In discussing these results, no mention has been made of the presence or absence of ion current. The periods during which the potentials were applied to the collector are shown in Figure 6, but no consistent correlation between the ion current and behavior of acetone concentration was found. Evidently, acetone was completely oxidized to carbon dioxide as a result of heating the filaments. This was true even though rigorous efforts were made in one run (No. 104) to exclude oxygen. In this run, the gasket previously attached to the cell was replaced with a Sylgard silicone rubber gasket designed to be more effective in stopping oxygen from entering the cell, but oxidation still occurred.

METHANOL

Using the techniques described for acetone, studies were made of the behavior of methanol. The methanol used to prepare the influent mix was certified as 82 ppm in nitrogen containing less than 5 ppm oxygen. This was diluted with oxygen-free nitrogen to give a methanol level of 18 ppm in the mixture fed to the cell. The silicone rubber gasket again was used with a 100 ml/min flow of helium passing between the rubber and the cell between diagonally opposed corners. Experimental results are presented in Figure 7.

The concentration of methanol in neither the rich nor the lean streams attained the level of methanol in the incoming gas, even though flushing with methanol had continued for 27 hours prior to heating the filaments (see FID data, Figure 7). This behavior was quite typical; even longer times had been observed with acetone. Also typical of normal behavior was the lower level of the rich stream as compared with the lean. A possible explanation is that the relatively higher surface area of the rich stream path resulted in a longer time constant for attainment of steady state concentrations of contaminants in this stream.

As for runs with acetone, FID data show that heating the filaments caused a pressure pulse. The second hump of the FID curve presumably is due to outgassing of impurities other than methanol. This hump is followed by a monotonic decrease to a low, nearly steady state level.

The GC curve for the methanol experiment indicates a decrease to essentially zero concentration of methanol in lean and rich streams.

Carbon dioxide for rich and lean streams reached a level of 47 ppm from a level of almost zero prior to heating. The 18 ppm of methanol would have given rise to 18 ppm of carbon dioxide, assuming complete oxidation; the rise in carbon dioxide above 18 ppm after heating in all probability is due to oxidation of methanol adsorbed at and outgassing from the inner surfaces of the cell.

The first period of ion current produced no clearly correlated responses in any of the parameters being followed. The second period, however, produced an FID trace that could be correlated with ion current, although at a low* confidence level--that is, the FID current decreased as a result of turning on the ion current and then increased when the current was turned off.

* Nevertheless, the behavior observed was consistent with behavior previously sensed but not reported because levels were so low.

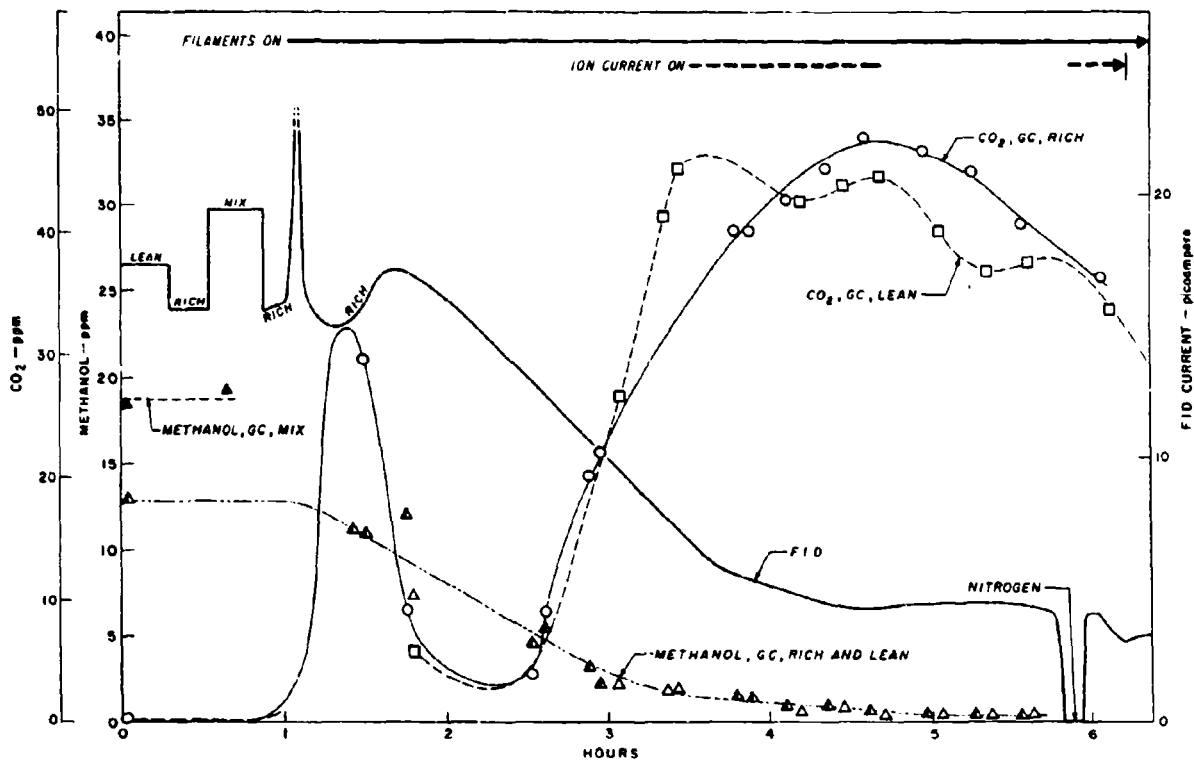

Figure 7
 EXPERIMENTAL RESULTS WITH METHANOL IN NITROGEN
 AND MINIMUM OXYGEN, AIR PURIFICATION CELL, RUN 106

PROPANE

The studies with propane were performed in the manner described for methanol. Propane was available at a concentration of 20 ppm in nitrogen and used without further dilution. The results are shown in Figure 8.* Propane's qualitative behavior was similar to that observed with acetone and methanol in the low-oxygen experiments. No enrichment of the rich-out stream with respect to the lean stream was noted (see GC data, Figure 8). Again, the presence of the potential to the collectors, with the resultant ion current, caused a just discernible decrease in FID current.†

SUMMARY OF EXPERIMENTAL RESULTS

Results obtained are presented in the idealized graphs shown in Figures 9 and 10. These graphs represent the qualitative behavior of each of the gases tested. In Figure 9, FID results representative of both rich and lean streams are plotted against the time during which the filaments were hot. Also shown is a curve representing the results of GC analysis which was specific for the contaminant gas under consideration.

As shown in Figure 9, the true concentration of the model contaminant gas dropped essentially to zero in about four hours. This time period coincides with the time constant observed for a cold cell and leads to the firm conclusion that the contaminant, whether acetone, methanol, or propane, was completely oxidized to carbon dioxide in a time appreciably shorter than this time constant. The GC results for carbon dioxide produced when filaments were heated confirm this conclusion.

The FID, on the other hand, did not drop to zero organic concentration. Although a true zero was shown to be possible with a cold cell, it was never observed with a hot cell. Instead, after an initial outgassing of organics (the hump in the FID curve), the level fell to a nonzero low equivalent to 1 to 4 ppm of acetone. Inasmuch as this organic was not detected in the GC analysis or eluted from the cold cell, it is probable that it is a fairly high-boiling compound available by diffusion from the cell's materials of construction or the silicone rubber sealants used. (As shown by GC analysis, it was not acetic acid, common to some of these silastics.) This organic apparently was resistant to oxidation, since the difference between the mixture and the effluents from

* Run 105.

† That this behavior was not due to electronics was established by observing the behavior of the FID current as a function of filament potential with cold filaments, that is, in the absence of ion current.

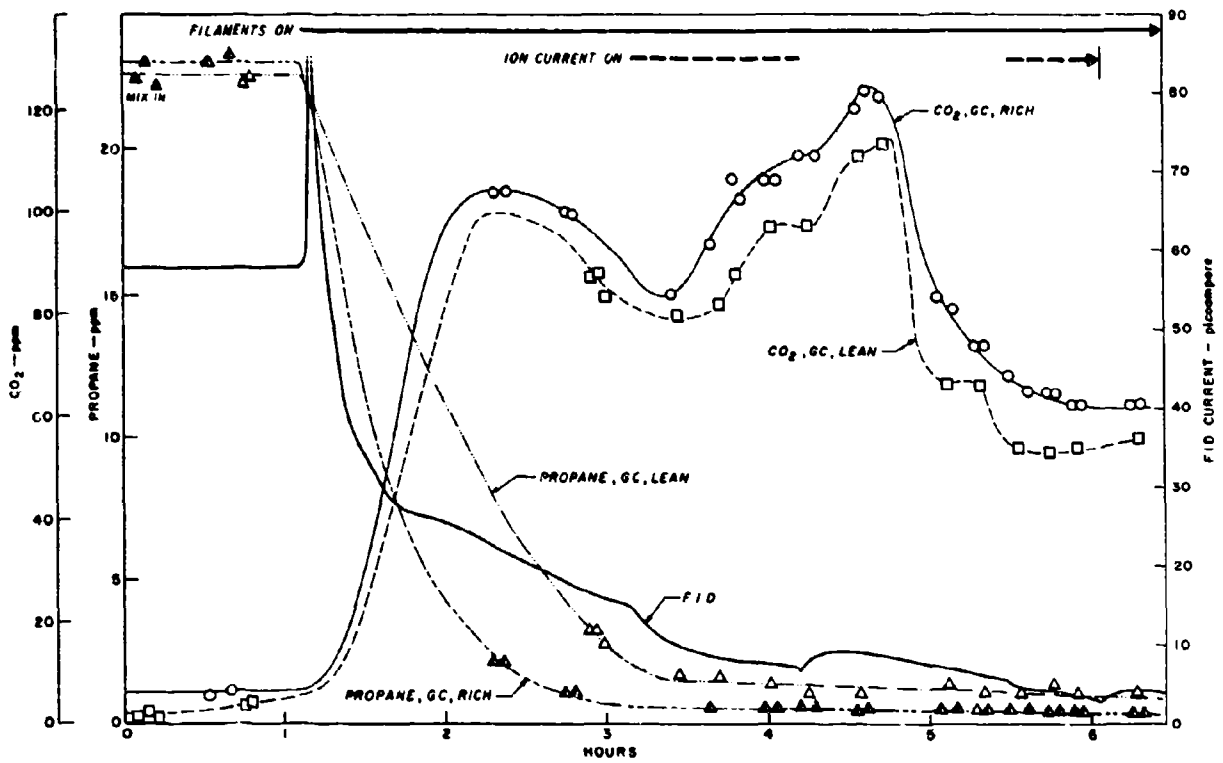

Figure 8

EXPERIMENTAL RESULTS WITH PROPANE IN NITROGEN AND MINIMUM OXYGEN, AIR PURIFICATION CELL, RUN 105

Figure 9
IDEALIZED BEHAVIOR OF EFFLUENT CONCENTRATION,
AIR PURIFICATION CELL

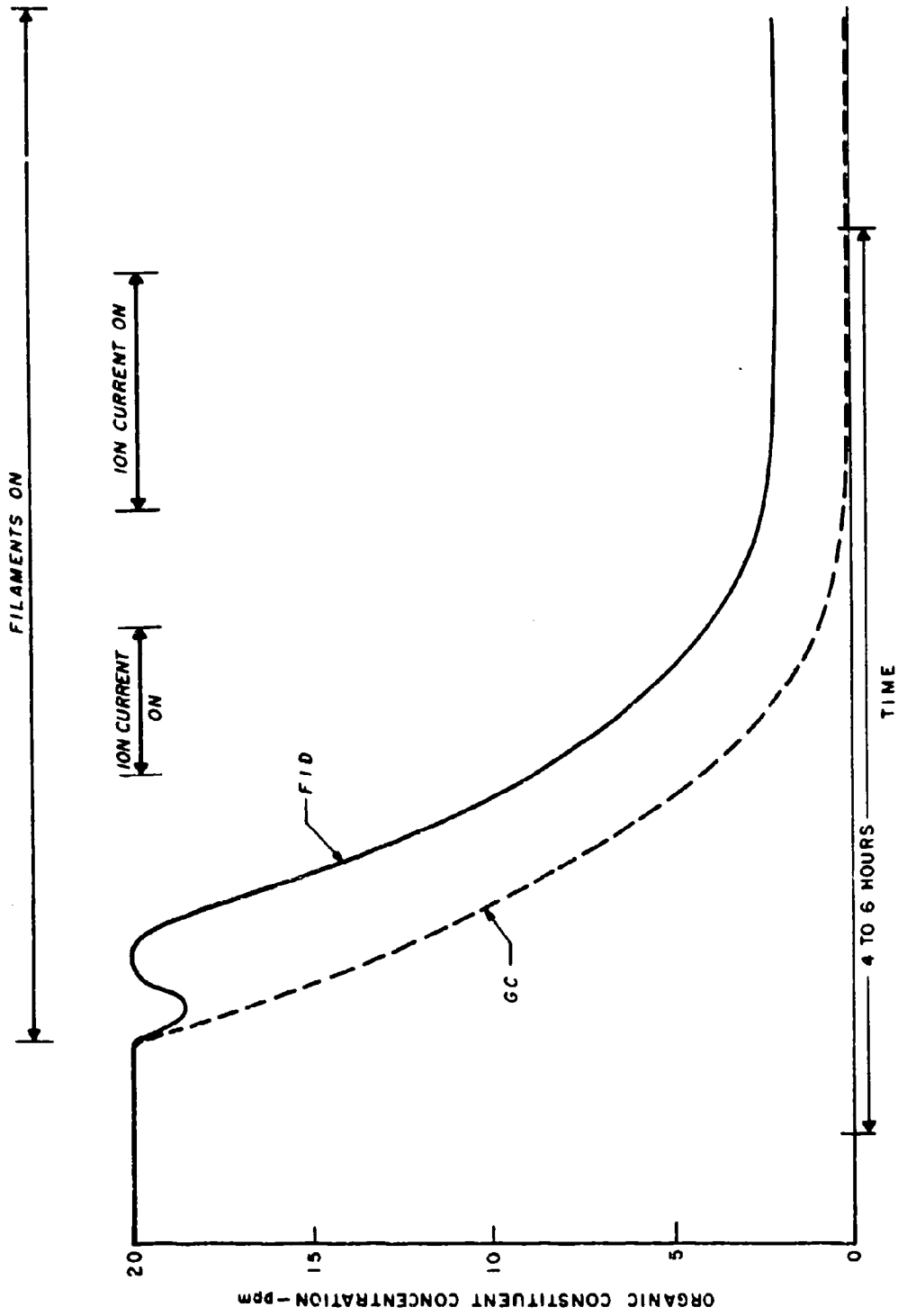
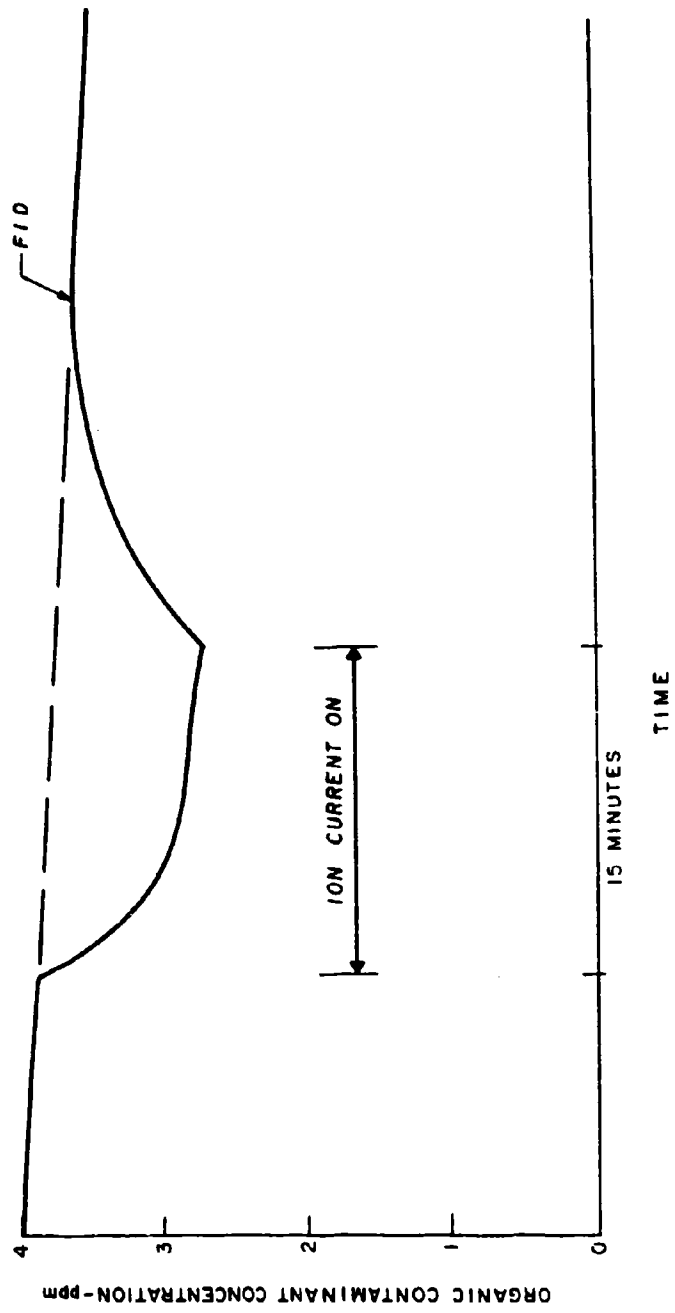

Figure 10

DETAIL OF IDEALIZED BEHAVIOR OF FID CURRENT AFTER INITIAL
RAPID CHANGES HAVE OCCURRED, AIR PURIFICATION CELL



the cell was about the same as the difference between zero and the level of FID current at high temperatures when sufficient time was allowed for steady state to be reached.

No enrichment could have occurred for acetone or the other contaminants after their oxidation* was essentially complete. During the period just prior to the disappearance of the model contaminants, no enrichment was observed with either detection technique, GC or FID. However, in this period the rate of change of contaminant concentration was so great that enrichment would have had to be an estimated 100% to be detected. In contrast, the estimated maximum attainable enrichment at the ion currents and contaminant concentrations used in the experiments is of the order of 10%. A small effect of the ion current on the FID current was repeatedly observed (see Figure 10) near the end of runs. Inasmuch as the model contaminant level had dropped to zero at this time, the effect must be ascribed to the unidentified organic impurity. Furthermore, clustering may be excluded as a possible cause since the ion current produced depletion of the rich stream rather than enrichment expected from the clustering model.

* The experimental results did not allow a clear decision on the source of the required oxygen; likely possibilities are discussed in Section IV.

SECTION IV

DISCUSSION, CONCLUSIONS, AND RECOMMENDATIONS

DISCUSSION

It is clear that the presence of hot platinum alloy wires (coated with β -eucryptite) promotes a rapid and complete oxidation of the three compounds tested even at trace concentrations of both oxygen and the organic compound. The source of oxygen in the nominally oxygen-free experiments could be any combination of oxygen desorbed from interior cell surfaces, traces of oxygen in the nominally oxygen-free influent gases, and oxygen released from the ion source materials. A truly oxygen-free environment cannot be achieved because of constraints imposed by the present apparatus. For example, the cell cannot be baked out under high vacuum because of its lack of mechanical strength and the presence of materials that would deteriorate at high temperatures.

Discussion of the oxidation mechanism can only be speculative because of the complex processes occurring within the cell. Vigorous convective stirring undoubtedly is taking place, probably augmented by an ion wind effect during periods of ion current. The hypothesis of ion wind stirring is supported by the accelerated drop in organic concentration on applying the polarizing voltages. This observation suggests that mass transport to the neighborhood of the hot wires is an important factor in determining the oxidation rate and, hence, that this neighborhood is the region of oxidation, a reasonable conclusion. It is probable that the active oxidation volume is large compared with the ion source volume, because of a free radical mechanism of oxidation. In the original concept of the ion source, it was hoped that the high density ion current near the wires would sweep the region clear of organic compounds (at least the highly polar ones) and suppress thermal oxidation. The results given here for acetone and methanol suggest that this effect may not be sufficient to prevent oxidation. Another possible explanation is that the lithium ions themselves promote oxidation by undergoing ion-molecule reactions near the wires: there will be an "atmosphere" of such ions in the vicinity of the hot wires at all times, including periods when the polarizing potentials are not applied.

CONCLUSIONS

The feasibility of precipitation of trace constituents by collecting their clusters on small positive ions could not be demonstrated for the three compounds

judged to be most favorable to the process amongst their homologs. Further, it is highly unlikely that it can be demonstrated by further work within the constraints imposed on this experimental work, including most importantly the use of thermionic sources and cell pressures near atmospheric. A further constraint--that the carrier simulate a breathable atmosphere--was abandoned in the search for a discernible effect. The most severely limiting constraint, that of using thermionic sources, was imposed at the onset of this effort in order to exploit previous work on this type of source and thus reduce the effort required to develop a useful source of small positive ions. This limited purpose was achieved, although considerably more effort than anticipated was required because of the unusual environment in which the source operated and the unusual specifications placed upon it.

RECOMMENDATIONS

It is recommended that no further work be done using the present approach and, in particular, using a thermionic source of ions in direct contact with the atmosphere to be purified. Any future work to demonstrate feasibility should utilize a "cooler" source of ions, perhaps one developed especially for this work.

There are many possibilities for a usable ion source--corona discharge sources being one. The type of ion generated can be controlled to some degree by adjusting the composition of the gas blanketing the discharge. An interesting source of this type has recently been developed by Whitby (1966) for use in aerosol instrumentation wherein the discharge region is swept by a carrier gas at velocities near Mach 1, thus reducing space charge and recombination effects. Another possibility is to accelerate ions from one of the usual vacuum or low pressure sources, including thermionic sources, through a thin target window and into the atmosphere to be purified in the presence of a collecting field. Target thickness and field gradients would have to be carefully contoured so that most ions emerged into the atmosphere at near thermal energies. This would effectively isolate the source from the atmosphere to be purified.

The rapid and efficient oxidation encountered in these experiments suggests a possible utility of a hot β -eucryptite-coated surface for intentional oxidation of combustible impurities. It would be necessary to investigate the beneficial effect of the eucryptite before proceeding to exploit this further.

REFERENCES

- Doyle, G. J., Feasibility Investigations of Electrostatic Precipitation for Removal of Gaseous Trace Contaminants from Manned Cabin Atmospheres, AMRL-TR-68-111 (AD 678 927), Aerospace Medical Research Laboratories, Wright-Patterson Air Force Base, Ohio, July 1968.
- Doyle, G. J., and R. G. Caldwell, Feasibility of Removing Gaseous Contaminants from Manned Space-Cabin Atmospheres by Ionic Processes, AMRL-TR-66-22 (AD 635 522), Aerospace Medical Research Laboratories Air Force Base, Ohio, February 1966.
- Whitby, K. T., and C. E. Clark, "Electrical Aerosol Particle Counter and Size Distribution Measuring System for the 0.015- μ Size Range," Tellus, 18 (22), 573-586 (1966).

DOCUMENT CONTROL DATA - R & D

Security Classification

(The security classification of this report and abstract and indexing annotation must be entered when the overall report is classified)

1. ORIGINATING AGENCY (For reporting authors) Stanford Research Institute 19722 Jamboree Boulevard Irvine, California 92661		2a. REPORT SECURITY CLASSIFICATION UNCLASSIFIED	
		2b. GROUP N/A	
3. REPORT TITLE FEASIBILITY INVESTIGATIONS OF ELECTROSTATIC PRECIPITATION FOR THE REMOVAL OF GASEOUS TRACE CONTAMINANTS FROM MANNED CABIN ATMOSPHERES			
4. DESCRIPTIVE NOTES (Type of report and inclusive dates) Final Report 1 October 1968 - 15 April 1970			
5. AUTHOR(S) (First name, middle initial, last name) George J. Doyle Robert Weaver Quentin McKenna			
6. REPORT DATE October 1970		7a. TOTAL NO. OF PAGES 29	7b. NO. OF REFS 3
8a. CONTRACT OR GRANT NO. F33165-69-C-1047		9a. ORIGINATOR'S REPORT NUMBER(S) Stanford Research Institute Project No. PSU-7522	
8b. PROJECT NO. 6373		9b. OTHER REPORT NO(S) (Any other numbers that may be assigned (this report)) AMRL-TR-70-73 (AD 716 864)	
8c. Task No. 637302			
10. DISTRIBUTION STATEMENT This document has been approved for public release and sale; its distribution is unlimited.			
11. SUPPLEMENTARY NOTES This research is a continuation of that reported in AMRL-TR-68-111.		12. SPONSORING MILITARY ACTIVITY Aerospace Medical Research Laboratory Aerospace Medical Division Air Force Systems Command	
13. ABSTRACT <p align="right">Wright-Patterson Air Force Base, Ohio</p> <p>The feasibility of electrostatic precipitation of clustered lithium ions for removal of gaseous trace contaminants from atmospheres could not be demonstrated under the constraints imposed on the experimental work. The major difficulty was that the thermionic source caused oxidation of the contaminants (acetone, methanol, and propane at 1-25 ppm concentration). The source was designed to minimize thermal effects such as oxidation and consume about the minimum practical heating power density to produce the necessary ion current in atmospheres near 760 torr pressures. Even at trace concentrations of oxygen in nitrogen, the oxidation rates were sufficient to obscure any possible precipitation effects. Further work should be done using a cooler ion source or, preferably, a source effectively isolated from the atmosphere to be purified. Development of such a source seems completely feasible on the basis of present technology.</p> <p>NOTE: Copies of this TR are available only from DDC or the National Technical Information Service, Springfield, VA 22151</p> <p>Key Words: Experimental application of: Clustering about lithium ions: rates, equilibria Ion-molecule interactions Ionic processes</p> <p>To problems of: Purification of space-cabin atmosphere Removal of pollutants from air</p> <p align="right">Air pollution, Gas purification, Pollution abatement, Atmos. purification</p>			

AD-716 864

DD FORM 1473
1 NOV 65

Security Classification

SUMMARY

The ion source was improved to gain the longer service life necessary for obtaining experimental data at a high confidence level. Improvements consisted of finding a better alloy for the heater wires of the ion source grid (8% tungsten in platinum alloy, Sigmund Cohn Corporation) and refining the method of mounting and tensioning these wires. These improvements increased service life from the original two to four hours to approximately twelve hours at 1000 C. During the course of the experimental work, continual changes were made in the apparatus to reduce errors. Gas chromatography was used to supplement the flame ionization detector in monitoring influent and effluent gases, particularly for carbon dioxide and the introduced contaminants.

Three contaminants--acetone, methanol, and propane--were studied over the concentration range of 1 to 24 ppm (v/v). The first significant experiments with acetone in air showed that acetone was being completely oxidized to carbon dioxide and that this effect completely overshadowed any possible cluster precipitation effect. To suppress oxidation, all further work was done in a nitrogen carrier with precautions to suppress diffusion of atmosphere oxygen through the seals of the purification cell. However, even at the resultant trace oxygen concentration, oxidation overshadowed any effects due to lithium ion current. This was also true of the other two contaminants, methanol and propane. Further work on this approach should be done using an ion source especially designed to avoid the presence of hot surfaces within the purification cell.

Since clustering is a well-established classical phenomenon, first observed by its interference with older (before about 1930) determinations of ionic mobility, and since the energies of cluster formation have been shown to be in the tens of kilocalories range (Doyle and Caldwell, 1966), there is little doubt that clustering can be used to remove trace polar impurities from gases, at least on a laboratory scale. However, this work has shown that this cannot be experimentally demonstrated using thermionic sources in contact with a test atmosphere containing oxygen down to trace concentrations. The source used in this work was designed with extreme precautions to minimize such thermal effects as oxidation.

RECEIVED
NATIONAL TECHNICAL
COPY 1971
INFORMATION SERVICE