

AD 716211

Semi-Annual Technical Report  
November 23, 1970

EPITAXIAL SUBLIMATION METHODS FOR THE STUDY OF PSEUDO-BINARY  
SEMICONDUCTOR ALLOYS

Naval Ordnance Laboratory  
Silver Spring, Maryland 20910

University of Pennsylvania  
Philadelphia, Pennsylvania 19104

1. The enclosed technical report describes work performed under ARPA Order No. 1597 (February 19, 1970) jointly by the Naval Ordnance Laboratory and the University of Pennsylvania.
2. The period covered is May 7, 1970 thru November 23, 1970 for NOL and June 1, 1970 thru November 23, 1970 for the U. Pa. Slightly different starting dates were occasioned by local administrative considerations at the two Institutions.
3. Brief individual research progress reports are given below.
4. As a result of the work initiated under this joint program the Naval Air Systems Command has awarded a joint research assignment (Task No. A-310-310B/WR008-03-02 Prob. 102, 30 October 1970) entitled "Variable Band Gap Emitters and Detectors" to NOL (R. F. Bis and J. R. Dixon) and the U. Pa. (J. N. Zemel and S. Rabi).
5. Interaction between NOL and the U. Pa. research groups has greatly facilitated technical progress in this and other areas. As examples of the benefits of the joint program, are:

A. Numerous personal visits have been made by project workers at the one Institution to the other Institution, averaging one visit every two weeks. The capabilities and research progress of the Institution are then rapidly applied to the other. Transport calculations being made at NOL, for example, are being applied to measurements made at U. Pa.

B. Joint consultation and lecture sessions were arranged at NOL and attended by the U. Pa. group, with Professor T. B. Grimley of the University of Liverpool, on the subject of "Surface States, Surface Defects and Chemisorption."

(Advantage was taken of Professor Grimley's presence in the Washington area for the Surface Science Symposium of the American Vacuum Society meeting in October, 1970.)

6. Several publications have been made and talks given at Scientific Meetings, reporting progress on work performed under these ARPA orders:

**PAPERS:**

R. F. Greene, D. Bixler and R. N. Lee, "Semiconductor Surface Electrostatics", J. Am. Vac. Soc., to be published January 1971.

S. Rabi, "The Band Structure of IV-VI Alloys" J. Am. Vac. Soc. (Accepted for publication, January 1971).

**PAPERS PRESENTED:**

R. F. Greene, D. Bixler, and R. N. Lee, "Semiconductor Surface Electrostatics", paper 0-5, Surface Science Symposium, Am. Vac. Soc., Washington, October 20-23, 1970.

S. Rabi, "The Band Structure of IV-VI Alloys", paper A-6  
Surface Science Symposium, Am. Vac. Soc., Washington, October  
20-23, 1970.

Naval Ordnance Laboratory  
Silver Spring, Maryland 20910

ARPA SEMI-ANNUAL TECHNICAL REPORT

EPITAXIAL SUBLIMATION METHODS FOR THE STUDY OF PSEUDO-BINARY  
SEMICONDUCTOR ALLOYS

Theoretical Program

A. Semiconductor Surface Electrostatics. A calculation has been made (1,2) of the detailed structure of the electrostatic potentials produced near a semiconductor interface by localized charges (e.g. chemisorbed ions) which occupy interfacial lattice sites in a random or ordered manner. The statistical properties (spectral density of the surface Fourier transform) of the potential are expressed in terms of the autocorrelation of charge distribution over the surface lattice. Fermi-Thomas screening and bulk static dielectric constants are used.

This treatment replaces the conventional one-dimensional model of the surface space charge region which lacks all structure associated with the point nature of the trapped charge and with its arrangement. There is a clear division of the space charge potential into a coherent term, which corresponds to the band bending, and an incoherent term, which produces scattering (see section B below).

The present treatment permits quantitative calculations of basic interface problems such as: transport and scattering in the space charge region (see section B below), electrostatic interaction between charged chemisorbed ions and their trap state energies, interface noise problems, etc.

Another result of the present calculation is a simple expression for the screening correction to the dielectric image potential of an electron or hole near a semiconductor interface. Dielectric image potentials significantly affect surface scattering, surface recombination and trapping, chemisorption processes, and tunnelling currents. Simple calculations of these screened image effects are being made.

(R. F. Greene, D. Bixler\*, and R. N. Lee, Naval Ordnance Laboratory).

#### B. Carrier Scattering by Incoherent Space Charge Potentials.

(R. F. Greene and J. Malamas\*\*) A preliminary calculation is nearly complete of the scattering of electrons and holes by the incoherent part of the space charge potential calculated in section A above. There is strong evidence (3) that the dominant static scattering mechanism in surface space charge regions is that of screened surface trapped charges. A theoretical treatment of this was made a few years ago (4) on the assumption that the scatterers acted independently, that

---

\* not supported by this contract.

\*\* supported by the Night Vision Laboratory, Fort Belvoir, Va.

they had bulk screening, and that the dielectric image potential could be ignored. Such a theory is applicable only at very low surface charge concentrations, and is only qualitative in nature. The present calculation treats the entire surface charge array as a single giant scatterer, and includes screened dielectric potential terms correctly, using the results of section A above. Consequently the new theory should be applicable for all surface charge concentrations. The theory is made tractable by introduction of the statistical properties of the scatterer at the appropriate stage. (The scattering cross sections are evaluated in terms of the spectral density of the space charge potential.)

This preliminary theory uses the Born approximation and free electrons. The final form of the theory will use a phase shift analysis of Bloch functions appropriate to specific IV-VI crystals. (R. F. Greene, Naval Ordnance Laboratory, J. Malamas\*\*, Night Vision Laboratory, Fort Belvoir, Va.)

1. R. F. Greene, D. Bixler, and R. N. Lee, Surface Science Symposium, Am. Vac. Soc., Washington, D. C., October 20-23, 1970.

2. R. F. Greene, D. Bixler and R. N. Lee, accepted for publication, J. Am. Vac. Soc. (to be published January 1971)

(A preprint of this paper is appended hereto).

3. T. I. Kamins, and N. C. MacDonald, Phys. Rev. 167, 754 (1968).

4. R. F. Greene and R. W. O'Donnell, Phys. Rev. 147, 599 (1966).

## Experimental Program

Fabrication of the experimental apparatus is now complete, and preparations are being made to grow the first PbS films in ultra-high vacuum. The vacuum chamber which has been constructed makes possible for the first time a wide variety of in situ measurements on freshly deposited thin films in ultra-high vacuum. A schematic of this chamber is presented in Figure 1. The unusual flexibility of the system is primarily due to the use of a unique vacuum feedthrough which permits cooling as well as translational and rotational motion of the sample. A standard linear motion feedthrough on the side of the chamber is used to position either a deposition mask or a transparent field plate in front of the sample. The sample is translated down into the tail section of the chamber for galvanomagnetic measurements. The film deposition source is located in the pumping throat of the chamber, and a number of ports on the chamber provide for optical windows, vacuum gauges, residual gas analyzer, thin film monitor, etc. Provisions have been made for the future addition of a LEED monitor and contact potential difference equipment to the chamber. A top view of the vacuum table layout is presented in Figure 2.

The procedures which can now be carried out in ultra-high vacuum include: (a) deposition of the semiconductor film at a measured rate on a heated substrate, (b) measurement of the galvanomagnetic coefficients of the film, (c) measurement of

a variety of field effects, (d) measurement of the above parameters with the sample illuminated through sapphire windows, (e) measurement of the above parameters with the sample at temperatures between 77 K and 600 K. In addition, the sample can be exposed to measured pressures of oxygen, hydrogen, etc. between  $10^{-8}$  and 100 Torr, and the composition of the gases in the system analyzed.

The analysis of the gases in the system is being carried out with a Spectrascan 750 Residual Gas Analyzer which was recently acquired. This instrument will cover the mass Spectrum from 1 to 750 amu. with a resolution of 500 or better, and is sufficiently sensitive to follow the evolution of gas from the small samples used in the experiments.

The requirements of the program have dictated an upgrading of the ultra-high vacuum system, and this is now completed. A 1600 l/sec Granville-Phillips Electro-Ion Pump has been fitted to the system, replacing a 90 l/sec pump which was inadequate to handle the gas loads which will be encountered during the experiments. Also, a Viton-seal gate valve has been replaced with an all metal valve to eliminate contamination due to the outgassing of the elastomer. After a mild bakeout, the system now reaches a base pressure of  $3 \times 10^{-10}$  Torr, and the dominant residual gases are hydrogen and carbon monoxide. Ultimate pressures below the X-ray limit of the Bayard-Alpert gauge are expected after baking above 300 C.



A new ultra-high vacuum laboratory is now in preparation, and the move to this space is anticipated in the near future. The new laboratory will incorporate improved facilities for the preparation and processing of vacuum parts and thin film materials, and the larger floor area provided will contribute both to the efficiency and flexibility of the program. (R. N. Lee, Naval Ordnance Laboratory)

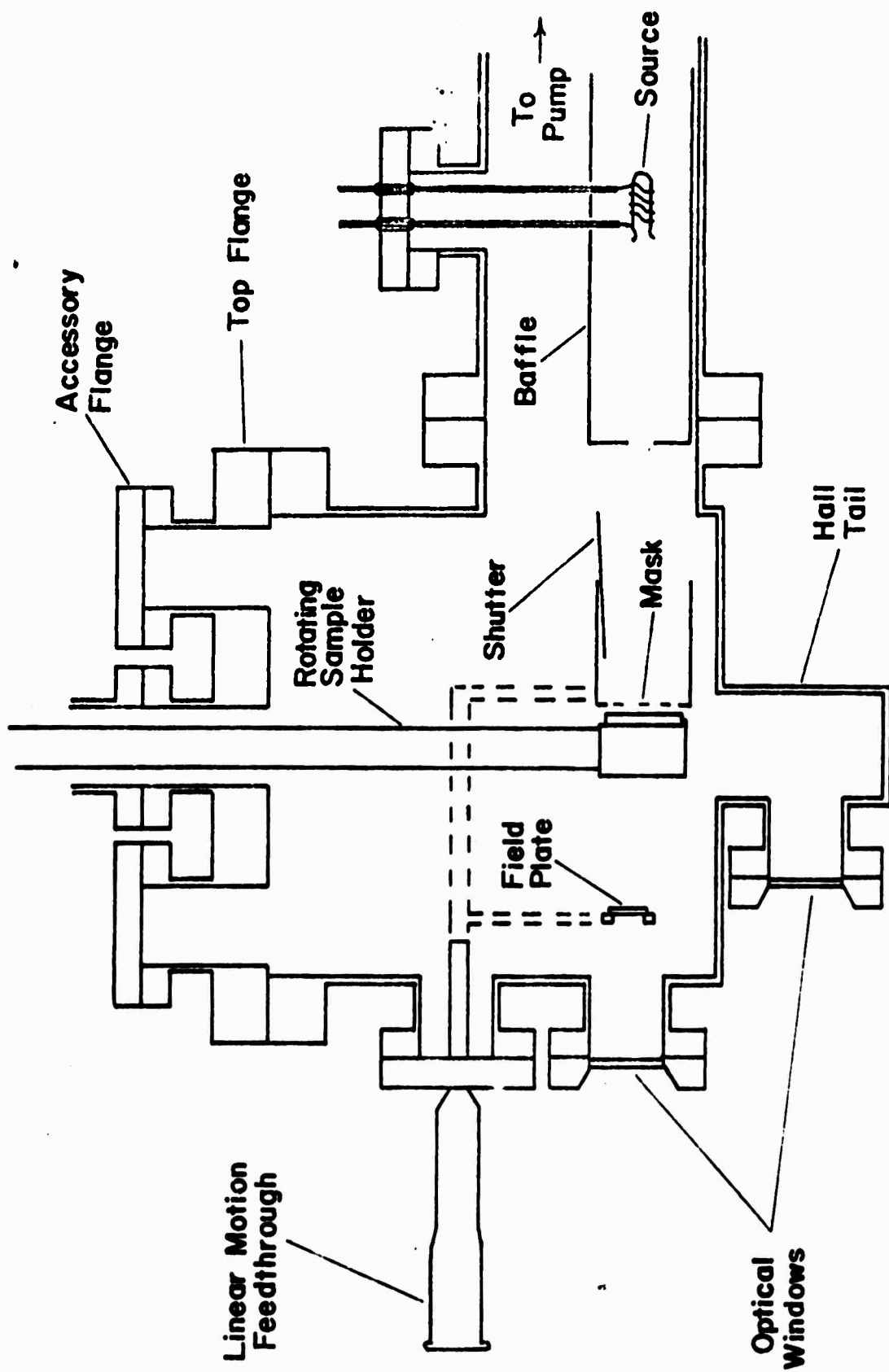

**FIG. 1 - VACUUM CHAMBER SCHEMATIC**

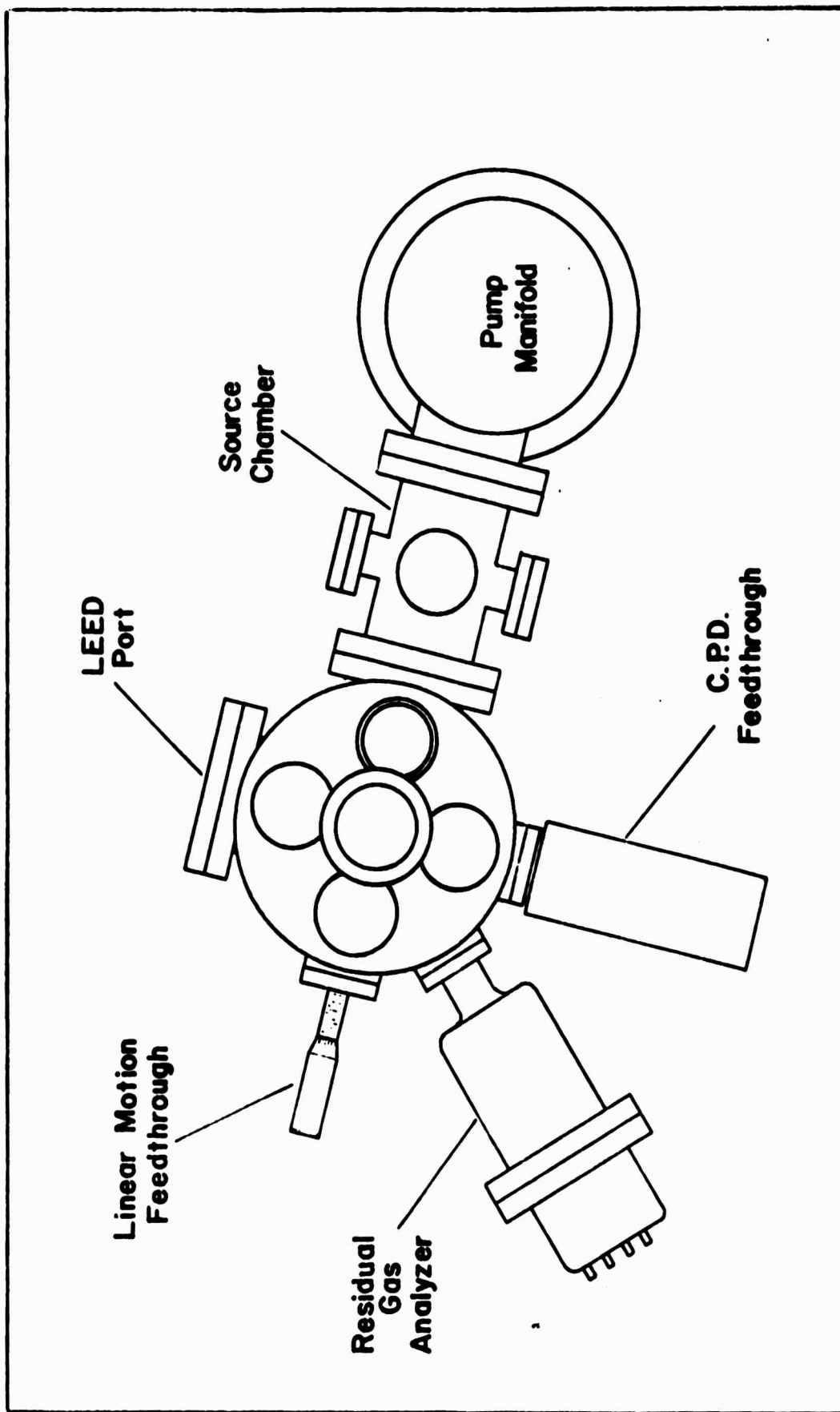

FIG. 2 - VACUUM TABLE - TOP VIEW