

Technical Research Note 223

AD

AD 713463

HUMAN PERFORMANCE EXPERIMENTATION IN NIGHT OPERATIONS: TECHNOLOGY AND INSTRUMENTATION FOR FIELD RESEARCH

Aaron Hyman, Jack J. Sternberg, and James H. Banks

COMBAT SYSTEMS RESEARCH DIVISION

Reproduced by the
CLEARINGHOUSE
for Federal Scientific & Technical
Information, Springfield, Va. 22151

DDC
RECEIVED
NOV 2 1970
P C



Behavior and Systems Research Laboratory
Office of the Chief of Research and Development
U. S. Army

June 1970

This document has been approved for public release and sale; its distribution is unlimited.

7

DISCLAIMER NOTICE

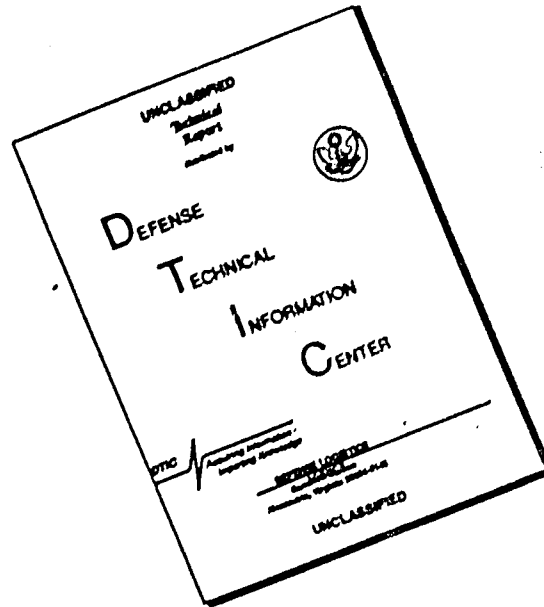

THIS DOCUMENT IS BEST QUALITY AVAILABLE. THE COPY FURNISHED TO DTIC CONTAINED A SIGNIFICANT NUMBER OF PAGES WHICH DO NOT REPRODUCE LEGIBLY.

BEHAVIOR AND SYSTEMS RESEARCH LABORATORY
An activity of the Chief, Research and Development

ACCESSION for	
CPSTI	WHITE SECTION ✓
DCG	BLUF SECTION
UNANNOUNCED	
JUSTIFICATION	
BY	
DISTRIBUTION AVAILABILITY CODES	
DIST.	AVAIL. and/or SPECIAL
/	

J. E. UHLANER
Director

NOTICES

DISTRIBUTION: Primary distribution of this report has been made by BESRL. Please address correspondence concerning distribution of reports to: Behavior and Systems Research Laboratory, Attn: CRDMRC/BESRL, Room 239, Commonwealth Building, 1320 Wilson Blvd., Arlington, Virginia 22209.

FINAL DISPOSITION: This report may be destroyed when it is no longer needed. Please do not return it to the Behavior and Systems Research Laboratory.

NOTE: The findings in this report are not to be construed as an official Department of the Army position, unless so designated by other authorized documents.

Technical Research Note 223

AD

**HUMAN PERFORMANCE EXPERIMENTATION
IN NIGHT OPERATIONS: TECHNOLOGY AND
INSTRUMENTATION FOR FIELD RESEARCH**

Aaron Hyman, Jack J. Sternberg, and James H. Banks

COMBAT SYSTEMS RESEARCH DIVISION
Aaron Hyman, Chief

BEHAVIOR AND SYSTEMS RESEARCH LABORATORY

Office, Chief of Research and Development
Department of the Army

Room 239, The Commonwealth Building
1320 Wilson Boulevard, Arlington, Virginia 22209

June 1970

Army Project Number
2Q024701A723

Night Operations a-00

This document has been approved for public release and sale; its distribution is unlimited.

BESRL Technical Research Reports and Technical Research Notes are intended for sponsors of R&D tasks and other research and military agencies. Any findings ready for implementation at the time of publication are presented in the latter part of the Brief. Upon completion of a major phase of the task, formal recommendations for official action normally are conveyed to appropriate military agencies by briefing or Disposition Form.

FOREWORD

The NIGHT OPERATIONS Program within the Behavior and Systems Research Laboratory is concerned with problems in optimizing human performance in relation to night vision devices and related sensors. Specific aspects deal with determining: 1) performance effectiveness with sensor systems; 2) factors that affect performance; and 3) means of improving effectiveness. The entire research program is responsive to requirements of the Combat Developments Command and is conducted under RDT&E Project 20024701A723, "Human Performance in Military Systems," FY 1971 Work Program.

To further the research program, a field unit has been established at Fort Ord, California where, with the support of the Combat Developments Command Experimentation Command (CDCEC), studies are currently being conducted with passive night vision devices. The Behavior and Systems Research Laboratory deeply appreciates the excellent support given by CDCEC, both in personnel and material. Special acknowledgment is made of the efforts of the Commander, Brigadier General T. W. Brown and of Project Team III which, under the command of Lieutenant Colonel G. Van Hazel, directly supported the research activity.

Technical Research Report 1163, Search Effectiveness with Passive Night Vision Devices, June 1970, reports more fully on completed phases of the program and findings which have resulted from the field experimentation. The present Technical Research Note deals primarily with the technology of the field experimentation developed by BESRL and describes the instrumentation developed.



J. E. UHLANER, Director
Behavior and Systems
Research Laboratory

HUMAN PERFORMANCE EXPERIMENTATION IN NIGHT OPERATIONS: TECHNOLOGY AND INSTRUMENTATION FOR FIELD RESEARCH

BRIEF

Requirement:

Overall requirements of the research are two-fold: 1) to evaluate the effectiveness of performance with night vision devices and sensors, and to develop methods of improving performance; 2) to develop instrumentation to measure and record performance during field experimentation. The present publication deals primarily with the second requirement.

Procedure:

Concepts were required for field experimentation methodology and technology to deal with human performance problems associated with night operations, and particularly with the use of night vision devices and sensors. Concept of instrumentation essential to the field testing was developed from field experience during BESRL's early research on night vision devices at Fort Benning, Georgia in 1967-68, and more fully developed after the BESRL Field Experimentation Unit began work on night operations at Fort Ord, California in October 1968. Instrumentation embodying the requirements and essential characteristics as specified by BESRL was constructed by Systems Technology Associates and evaluated by the BESRL Field Experimentation Unit during experimentation with passive night vision devices.

Research Product:

The instrumentation system developed permits continuous real-time monitoring of operator performance during both training and testing, greatly enhancing control of activities. The system showed a high degree of reliability, with minimum down time.

The universal device platforms (UDPs) developed accept any passive night vision devices--and with minor modification other devices as well. Flexibility and variation in number and type of devices tested are thus built into the system.

With the UDP, azimuth and elevation of a device can be determined with 0.1° accuracy. Target acquisition can be determined much more accurately than with any non-instrumented system.

Device orientation can be sampled 5 times per second, providing a fine-grained record of the search behavior of all participants in an experiment. Recording of target acquisition and search data on magnetic tape permits immediate computer analysis and reduces data analysis time.

Utilization of Product:

The BESRL Data Acquisition and Recording System greatly aids in the collection of reliable and valid data in field experimentation. Adaptations of the system have been used by other agencies, including the Combat Developments Command Experimentation Command, the Night Vision Laboratories, and more recently, by Project MASSIER.

HUMAN PERFORMANCE EXPERIMENTATION IN NIGHT OPERATIONS: TECHNOLOGY AND INSTRUMENTATION FOR FIELD RESEARCH

CONTENTS

	Page
BACKGROUND	1
PROGRAM OBJECTIVES	2
Evaluation of Performance Effectiveness	2
Development of Field Research Technology	3
EVALUATION OF THE INSTRUMENTATION SYSTEM FOR FIELD EXPERIMENTATION	4
THE INSTRUMENTATION SYSTEM	5
Functional System Layout	6
Data Collection Subsystem	8
Executive Program Subsystem	9
Data Processing, Recording, and Display Subsystem	10
Appearance of Major Items in the System	12
DISTRIBUTION	18
DD Form 1473 (Document Control Data - R&D)	20
FIGURES	
Figure 1. BESRL data acquisition system functional block diagram	7
2. Universal Device Platform	14
3. Control Console	15
4. Control Console (Rear view)	16

HUMAN PERFORMANCE EXPERIMENTATION IN NIGHT OPERATIONS: TECHNOLOGY AND INSTRUMENTATION FOR FIELD RESEARCH

BACKGROUND

In recent years, the U. S. Army has recognized a need to improve its night operations capabilities. (See, for example, the 1964 study by the U. S. Army Combat Developments Command¹.) This need has led to the development of sensors which greatly improve night seeing and target acquisition capabilities. The development of these sensors has, in turn, created an urgent need for human factors research to assess and improve the level of human performance with the current generation of sensors and to provide human performance data which can be applied to improvement of the capabilities of future generations of sensors.

The Behavior and Systems Research Laboratory (BESRL) has established a Work Unit with the mission of conducting human performance experimentation to improve the capabilities of the combat soldier in night operations. Early work by this unit was conducted at Fort Benning, Georgia, in the winter of 1967-1968.² In the early summer of 1968, the U. S. Army Combat Developments Command (USACDC) requested that BESRL research in this area be expanded and accelerated. The request was formalized by USACDC in July, 1968. Concurrently, USACDC requested that the U. S. Army Combat Developments Command Experimentation Command (USACDCEC), Fort Ord, California support the desired BESRL research. Research by BESRL was initiated at Fort Ord in October 1968, with completion tentatively scheduled for September 1969.

In the following year, it became obvious that a longer term research effort was required and that this effort could best and most economically be conducted through establishment of a field experimentation unit at Fort Ord. Initial exploration of the feasibility of such a unit was undertaken in mid-1969 and culminated in an intra-service Support Agreement in December 1969, establishing the BESRL Field Experimentation Unit as a tenant of Fort Ord with primary mission support continuing to be supplied by USACDCEC.

¹ U. S. Army Combat Developments Command. Night Operations and the Employment of Night Vision Devices (Unclassified title). November 1964. SECRET.

² Farrell, John P., James H. Banks, and Jack J. Sternberg. Search Effectiveness with the Starlight Scope and 7 x 50 binoculars. BESRL Technical Research Report 1164. June 1970.

PROGRAM OBJECTIVES

Evaluation of Performance Effectiveness

The Army has given high priority to the development and fielding of advanced systems for surveillance, target acquisition, and night observation. The effectiveness of any system is complexly determined by the characteristics of the system, the way the system is employed, and the behavior of the human being in the system. Evaluation of system effectiveness must be in terms of the interaction of all these factors rather than separately in terms of the effectiveness of the equipment, or the method of employment, or the human operator. For a comprehensive evaluation of total system effectiveness, systems measurement beds must be developed which permit the determination of the relative contribution of equipment factors, employment factors, human factors, and their interactions. When these contributions are understood, suggestions leading to improvement of total system effectiveness become possible. The research conducted by BESRL is intended to provide information which will aid in the solution of the following problems:

Who should use night vision devices and sensors? Individuals differ greatly in their abilities to acquire targets with these devices. To what are these differences attributable? To what extent can these differences be reduced by training? What kind of training? If selection is necessary, on what basis can selection be made?

How should the devices be used? What are the proper search techniques? What are the implications of human capabilities and limitations for employment and deployment of men and devices? How large an area can a man effectively search? How long can a man use a device effectively? What are suitable work-rest cycles? If two men with devices are used, should they be assigned separate or overlapping search sectors?

Which devices should be used and under what conditions? The devices differ in their characteristics and capabilities and are affected differently by changes in conditions. What is the relative performance with the devices under different light levels? On different types of targets? On targets at different distances? On different types of terrain--open versus cluttered with trees, brush, and rocks? For different tactical applications?

What should be the Basis of Issue (BOI) and Mix of devices? How much is gained in target acquisition if two operators search with devices of the same type? Three operators? How much is gained if two or more men use different types of devices?

Questions such as these can be answered only by extensive and rigorous experimentation. The results of this experimentation provide information for operational employment, training, and selection, and for the development of concepts, doctrine, and organization. The information provided forms a basis for subsequent troop tests and provides the parametric data essential for effective linear modeling and war games.

The determination of the complex interactions, of the man, the device, and the operational situation provides valuable information for the design of future generations of devices.

Development of Field Research Technology

In order to conduct meaningful field evaluations of human performance, a technology was required which would make it possible to collect reliable and valid experimental data under field conditions. Existing instrumentation, procedures, and techniques were not adequate for research of this type. Development of an appropriate technology was an essential precursor to the conduct of the field experimentation--a technology which included training, testing, and control methods and procedures as well as special experimental techniques and instrumentation.

Methods and procedures had to be developed which would insure that all player, supporting, and controller personnel are properly carrying out their assigned missions. Each participant has to be oriented, motivated, and trained for his job. Because of the large number of test and environmental factors and the number and differing types of personnel involved, a great deal of procedural redundancy, as well as constant monitoring, is required in order to maintain a standardized testing situation.

Special experimental techniques had to be developed in order to partial out the effects of various factors on performance. Identification of the relative contribution of these factors to performance can reveal which subsystem elements need to be improved in order to improve overall system effectiveness.

An instrumentation system which would provide accurate measures of target detection and search behavior had to be developed and evaluated. This system had to be flexible and reliable under widely varying field conditions, provide for simultaneous recording of a variety of data, allow for control and monitoring of the players, and provide a data output that could be rapidly analyzed.

The methods and procedures and the experimental techniques which were developed, as well as some of the research findings, are described in considerable detail in another report.³ The present publication provides a description and evaluation of the effectiveness of the instrumentation system developed (under contract to the Army) by Systems Technology Associates following concepts provided by BESRL research scientists.

³ Sternberg, Jack J. and James H. Banks. Search Effectiveness with Passive Night Vision Devices. BESRL Technical Research Report 1163. June 1970.

EVALUATION OF THE INSTRUMENTATION SYSTEM FOR FIELD EXPERIMENTATION

The basic element in the instrumentation is the universal device platform (UDP). The UDP can accept any of the passive night vision devices and, with minor modification in the form of adaptors, other types of devices as well, affording maximum flexibility of the system and permitting variation in number and type of devices used. Each UDP contains instrumentation which permits the determination of orientation (both azimuth and elevation) of a device with a 0.1° accuracy. It also contains multiple response buttons for recording up to six responses from each player. The UDP thus permits the measurement of target acquisition with a much higher degree of accuracy than would be possible with any non-instrumented system.

Output from the UDP is fed into a data recording system which records, on magnetic tape, device orientation and all player responses. In experimentation reported elsewhere⁴, device orientation was sampled five times per second, thus providing a complete and fine-grained record of the search process used by all players. The recording of data on magnetic tape permits immediate computer analysis, without the hand preparation otherwise required, thus reducing data analysis time. The tapes also constitute an extensive library of search performance and permit detailed analyses of search behavior.

The system also permits continuous monitoring of player performance by providing real-time visual displays of player search behavior and target acquisition responses, as well as a graphic hard-copy record of search and target acquisition. This monitoring capability was found to be essential. During training, it resulted in quick identification of players who needed additional instruction, thus reducing training time and assuring adequate training for all players. During testing, it made it possible to identify players who were not cooperating, not following correct procedures, or both. Control of players and the resultant reliability and validity of the data was thus enhanced.

The system showed a high degree of reliability, with a minimum of down time. Reliability was increased by aspects of the system which permit checks to be conducted on system operation both before and during a run, thus enhancing not only system reliability but also the reliability and validity of the data collected. The use of magnetic tape recording makes it possible to get a computer output immediately after each night's run. From this, quick identification and location of system malfunction can be made, with consequent rapid correction of the malfunction. Accumulation of inadequate data can thus be avoided with a resulting savings in military resources.

⁴ See footnote 3 on page 3.

THE INSTRUMENTATION SYSTEM

The system consists of as many as ten field-mounted universal device platforms (UDPs) upon which the night vision devices are mounted, a van-mounted control console which houses the electronic control and data recording equipment, and various interconnecting cables and power units. The entire system is transportable for use in testing under field conditions. The UDPs are mounted on heavy duty tripods, which are situated in field positions in the test area. The control console is mounted in a van, and interconnects with the UDPs via multi-conductor cables. An intercom is provided for voice communications between the UDP field positions and the console. Data from ten field positions can be accommodated simultaneously. The field positions can be located at distances up to 400 feet from the van-mounted control console.

The UDPs are equipped with adapters to accommodate a number of different night vision devices, such as the Miniaturized Night Vision Sight, AN/PVS-3 (MINI), the Small Starlight Scope, AN/PVS-2 (SS), the Crew Served Weapon Night Vision Sight, AN/TVS-2 (CSWS), the Night Observation Device, Medium Range, AN/TVS-4 (NOD), and others. The mounts rotate with respect to a fixed base, and also are adjustable in the elevation plane. Two shaft encoders, one for azimuth and one for elevation, provide pointing data to the control console. Each UDP is equipped with a series of switches with which the operator can enter response data into the system. Six such response keys, mounted in a manner to avoid interruption of the scanning process, are incorporated in each UDP.

The control console contains the recording equipment, the stored program processor, and the control and indicator assemblies. A time division multiplexer scans incoming data from the UDP positions, and all azimuth, elevation, and response data from the ten positions are recorded on magnetic tape. Thus, both target acquisition and fine-grain recording of search behavior are on tape and readily extractable for subsequent data reduction and analysis.

A processor is incorporated to extract pertinent data during the experiment on a near real-time basis and to display the results on a Teletype Model ASR-33^E printer. Instructions to the processor can be entered via the associated ASR-33 keyboard.

A digital chart recorder is also incorporated to provide a graphic hard-copy display of the search behavior and responses of any selected player on a near real-time basis. A second and simultaneous recording of the search tracking, and response behavior of a target monitor can also be entered for analysis purposes, if desired.

^E Commercial designations are used only for precision in describing the experiment. Their use does not constitute indorsement by the Army or by the Behavior and Systems Research Laboratory.

The indicator assembly contains numerical displays (NIXIE² tubes) which provide real-time visual presentation of azimuth and elevation data of any selected operator station to the nearest one-tenth degree. The associated response data are displayed on a lamp panel adjacent to the numerical displays. The control assembly, in addition to providing facilities for selecting player positions for display on the indicator assembly and chart recorder, also provides for calibration of pointing data and for entry of marking data via Delete, Event, and Manual Mark keys.

Functional System Layout

Figure 1 is the functional block diagram for the BESRL Data Acquisition System as implemented for testing and evaluating performance with different night vision devices. In the overall test activity, there are four significant physical locations: target area above and beyond the areas illustrated by Figure 1; the location of the test scenario director's field console, remote control, and/or communications with the target area personnel; the ten test stations for equipment and personnel that are to be tested; and the console of the data system operator located in a standard M-109 Shop Van.

Interrelating the four physical locations are three major functional subsystems. The executive subsystem, shown by the heavy line in Figure 1, interconnects all personnel who conduct the test activity--scenario director, target controller, and console operators. The data collection subsystem begins at the ten UDPs in the field and presents the data to the digital multiplexer within the control console. The display subsystem constitutes the interface between personnel conducting the test activity and the overall test and data acquisition activity. Thus, the hardware illustrated in Figure 1 is the command and control system of the entire testing activity. Commands are issued, activity takes place, and observed or measured results are conveyed back to the originator of the commands. The correlation between commands or activities and observed results is the measure of effectiveness of the subjects under test.

² Ibid.

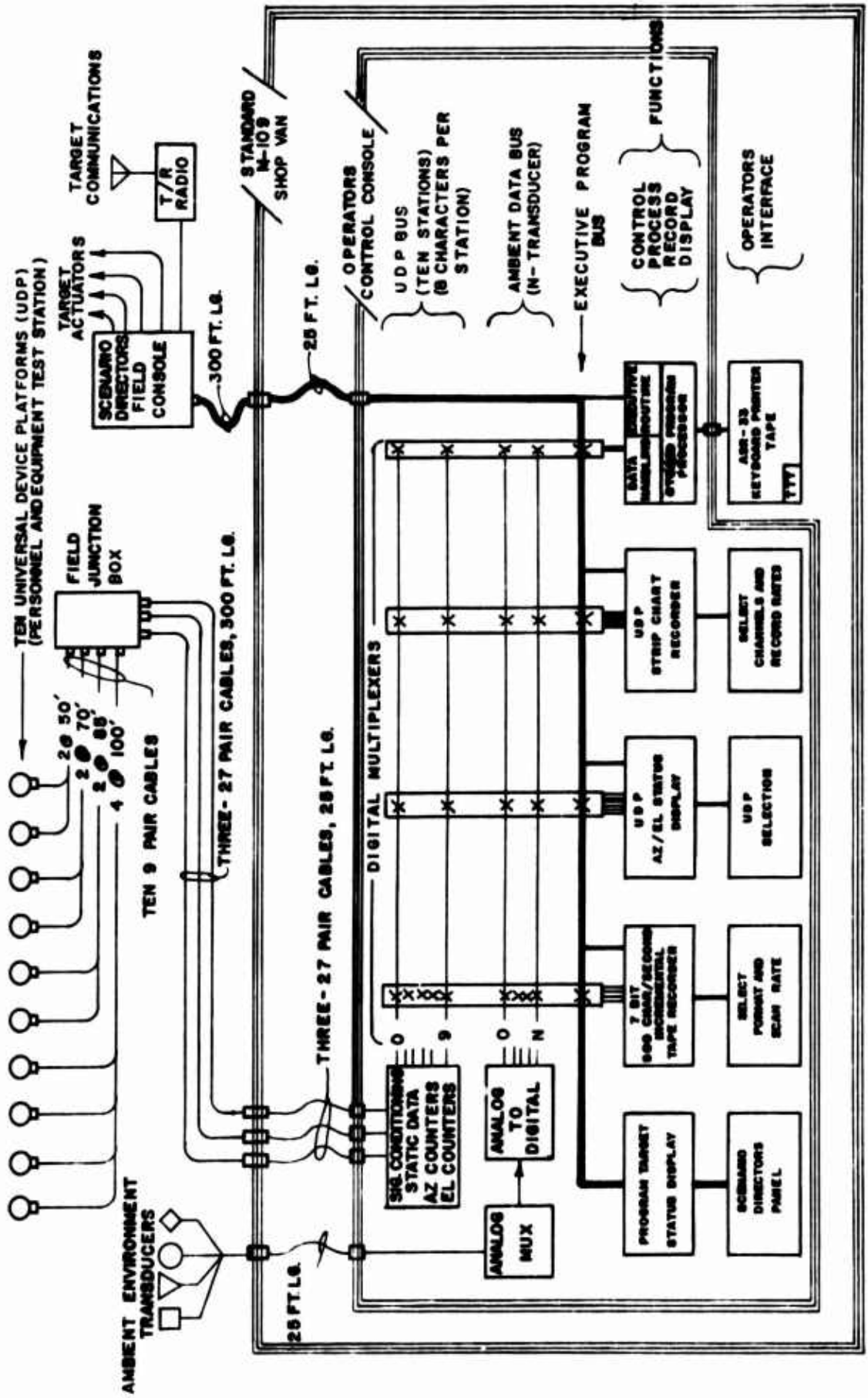

Figure 1. BESRL data acquisition system functional block diagram

Data Collection Subsystem

This subsystem consists of the ten UDPs at the personnel or equipment test stations, interconnecting cables, and signal conditioning and converting equipment located in the control console within the shop van, together with a subordinate section consisting of ambient transducers, interconnecting cables, analog multiplexing, and the analog to digital converters. All data collected are presented to the digital multiplexer as binary coded decimal or binary signals which are continuously present and accessible to each of the other subsystems connected to the digital multiplexer.

Universal Device Platform (UDP) Channels. Each of the ten UDPs consists of a tripod-mounted unit containing shaft encoders and response buttons. Sighting devices which test personnel aim at remote targets during testing are mounted on this housing. Each UDP is equipped with azimuth and elevation shaft encoders of the incremental type which produce square wave signals with transitions at each tenth degree of angular rotation. At the console, the signals from each shaft encoder are restored to standard logic level by input level detector circuits (Schmitt triggers), logically checked for direction of rotation and applied to an up-down counter which provides a binary-coded decimal output in increments of one-tenth degree. To calibrate or "zero" the counters, the UDPs are aimed at a known reference target and the two counters for each UDP are reset to zero by a button on the control console.

The other UDP inputs consist of a set of six momentary contact keys which the player may press to indicate target acquisition and other target-related information. At the console, these six signals are restored to standard logic level and then applied to one-bit storage circuits. Momentary operation of a key on the UDP by the player will set the memory and present a one-bit "set" state to the digital multiplexer. All such one-bit memories (60 for all ten UDPs) are reset by the magnetic tape data recording cycle. The A or Acquisition key also operates an additional one-bit memory which controls a training lamp on the control console. These ten memories and lamps (one for each UDP) remain in the "set" state until reset by a button on the control console.

To summarize, each of the ten UDP channels shown in Figure 1 presents the digital multiplexer with the set of data listed below. The sets of data are sampled simultaneously by the multiplexer and distributed to any of the recording or display devices connected to the multiplexer outputs.

UDP Identification	0 9	4 bits (BCD)
Azimuth angle	Hundreds	4 bits (BCD)
	Tens	4 bits (BCD)
	Units	4 bits (BCD)
	Tenths	4 bits (BCD)
	Azimuth sign	+, -,
Elevation angle	Tens	4 bits (BCD)
	Units	4 bits (BCD)
	Tenths	4 bits (BCD)
Elevation sign	+, -,	1 bit
Target Identification Keys	A thru F	6 bits

Inputs to Digital Multiplexer per UDP = 40 bits

Ambient Data Channels. At the left of Figure 1 is a multi-transducer data collecting subsystem for the identification and quantification of ambient environmental conditions while the prime test data are being collected. Field-mounted transducers external to the van can be provided for such data as light level, light transmission, temperature, humidity, and other information which is normally of an analog nature. In order to handle this information, a multiplexing scheme is provided to feed the input to an analog-to-digital converter. The output in digital form is then presented to the main multiplexer section. Where the analog-to-digital converter interfaces the digital multiplexer, each digitized value from one of the analog transducers is stored in digital form to provide continuous information on the ambient data bus. These digital values from the transducers are updated at the scan rate of the analog multiplexer. Inhibit signals are provided to permit sampling of the data for recording or display functions.

Executive Program Subsystem

In Figure 1, the executive function is identified by the heavy line that begins at the scenario director's panel at the lower left of the control console, enters each of the several elements that interface with the console operators, passes out through the console and shop van at the upper right, and terminates at the scenario director's field console. For conditions where the scenario director find it desirable to have visual contact with the players, the field console can be added to the existing cables and junctions boxes that provide remote control and signaling to target activators in the far field at fixed sites. Radio communications for other targets are an additional element in the executive program subsystem. Other test programs are conveniently conducted by the scenario director from the control console within the shop van.

An alternative to detailed supervision of the test program by the scenario director is provided when a stored executive routine in the processor attends to the sequence and housekeeping details of the test scenario. The director then uses the ASR-33 printer and keyboard as his interface with the system.

Program and Target Selection Panels. When the stored program processor is selected for executive functions, the executive program bus (heavy line of Figure 1) provides means for remote control of all connected equipment, and the processor directs the data gathering/recording activities as well as the program of target activity. The scenario director at the field console can also employ a panel implemented for full remote control and confirmation of functions ordered. He can execute detailed supervision over the test program just as the executive program of the processor would do.

When the test program is executed by voice communication, the main function of the scenario director's panel would be to add target-related data to the other data available in the digital multiplexer for recording or display by any of the connected equipment. At this level of implementation, the scenario director's panel allows the director to write a number on the magnetic tape indicating the particular target in view. In addition, he can place a mark on the tape indicating when the target is defilade or viewable. The scenario director's panel has an electronic tube display indicating the present target number. A switch is provided to increment, decrement, or reset the target number.

Stored Program Executive Routine. The accomplishment of part of the scenario director duties by means of an executive program in the stored program processor implies time sharing of the processor capacity with the data handling function related to reduction and analysis of test data. Test scenarios stored on paper tape would then enter the ASR-33 equipment and execute most of the routine actions of the test program and provide printed comment or decision points to the scenario director for resolution.

Data Processing, Recording, and Display Subsystem

This subsystem consists of four parts that have access to the digital multiplexer. Because all data are continuously present on the various bus sections of the digital multiplexer, each of the four parts may have independent sample and format routines for selecting the data to be used.

Incremental Tape Recorder. This unit is a magnetic tape recorder that provides incremental recording in seven-track IBM-compatible format, at rates of 500 characters per second. Tape from this unit constitutes the prime record of all test data presented to the data acquisition system, and is the input source for all off-line computer analysis of the test data. In the multiplexer, the parallel input lines from each UDP or ambient data channel are sampled simultaneously and transferred in parallel to a six-track serial shift register. The shift register is cleared as the data are recorded on the six record tracks of the magnetic tape at the rate of 500 characters per second. A parity bit is determined and recorded on the seventh track of the tape at each recording increment.

A representative record of one UDP channel would appear as follows:

Recording Sequence	1	2	3	4	5	6	7	8	
Recorded Data	UDP #	Azimuth Angle				Elevation Angle			
		X	X	X	X	Y	Y	Y	
Tape Track Number	1	1	1	1	1	1	1	1	
	2	2	2	2	2	2	2	2	
	3	4	4	4	4	4	4	4	
	4	8	8	8	8	8	8	8	
	5	A	B	C	D	-	E	F	-
	6	Event Mark	Manual Mark	Delete Code	-	Sign X	Delete Code	Delete Code	Sign Y
	7	P	P	P	P	P	P	P	P

The period between samples on any particular UDP or ambient data channel and the length of the digital multiplexer frame for magnetic tape recording are determined by the selected incremental recording rate and the number of UDP and ambient data channels in use at any one time. For example, with ten UDP channels in use and the tape recorder operating at 500 characters (increments) per second, $500 \div 8 = 62.5$ channels will be sampled each second. Any one UDP will therefore be sampled 6.25 times per second (disregarding time allowed for gaps between records on the magnetic tape).

Strip Chart Recorder. This unit consists of an electrostatic digital recorder providing a 100 mm full-scale range plus eight event-mark inputs and a five-level chart speed record on a seven-inch wide strip chart. Two digit BCD inputs are converted to one of 99 levels every two microseconds to produce a trace. The basic record includes the azimuth and elevation values (to nearest degree) plus six target identification keys for any UDP station selected by the operator, a second set of Az and El values either from the zero UDP (target monitor) station or from the panel dials set by the operator to read known target positions, and a five-level indication of chart speed. A subordinate stage of multiplexing scans the four two-digit BCD inputs at two microseconds per input to provide an input to the decoding circuit and writing head. Line-break coding (dots, dashes, and breaks) is applied to each of the four analog traces in the 100 mm range for easy identification of each trace. The strip record appears as follows:

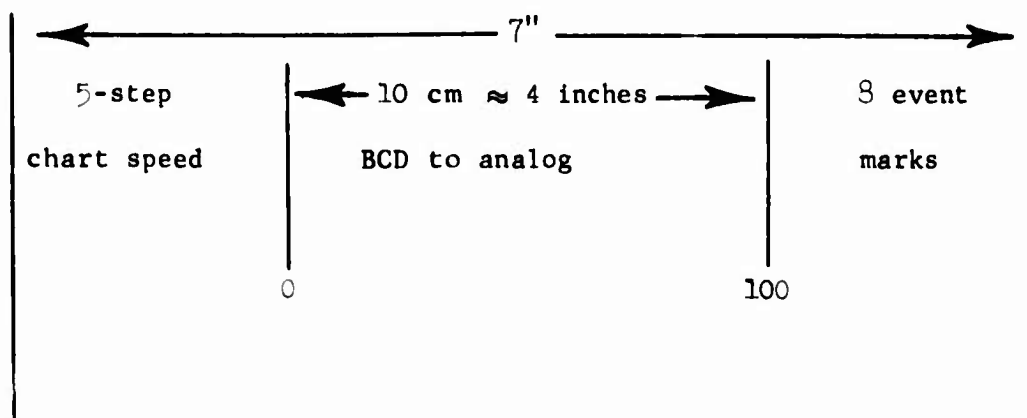

Processed Teletype Output. In addition to use of the stored program processor for the executive program function described earlier, an equally valuable use of its capacity is the partial reduction of current test data to determine if certain tests should be repeated while all personnel and equipment are on hand. On-line data reduction can also be performed to determine whether some test results are inconclusive and re-direction of the test program is called for.

An example of the type of printed output that would be useful to the console operator is the comparison of the Az/EI values of all ten UDP stations with the Az/EI values of the target as given by the checker or control panel dials, and the accumulation for each test subject of the elapsed time between the appearance of the target and observed responses. Ten columns of such values with a line of values added as each target is brought into view would provide rapid detection of many possible malfunctions in the testing activity.

Appearance of Major Items in the System

The BESRL Night Vision Data Acquisition and Recording System consists essentially of three basic physical elements: the universal device platforms, the control console, and the teletypewriter unit, plus associated ancillary equipment. The universal device platforms are designed for field use and are weatherproof to avoid damage to the electronic equipment in the event of inclement weather. The control console is designed for mounting in a standard M-109 shop van, and the cabinets are equipped with shock mounts to protect the equipment during transit. Physical characteristics of the various units which comprise these basic items are given below.

Universal Device Platform (UDP). The UDP serves as a mount for the night vision devices, and contains the electronic equipment for encoding positional data and player responses (see Figure 2). The unit, excluding the night vision device, is approximately three feet in height when stowed, and weighs approximately 60 pounds. The UDP consists of an encoder assembly, which houses the shaft encoders and response keys, and a heavy-duty tripod equipped with a panhead adaptor. Individual mounting accessories are provided to accommodate any of the several night vision devices such as the MINI, SS, CSWS, and NOD. A special pedestal for measurement of elevation is provided for the NOD, because of its different configuration.

The tripods have telescoping tubular legs for gross height adjustment. Final height is adjustable over a range of 18 inches using a hand crank to operate the elevator mechanism. A ring brake holds the column securely at the desired height. The panhead mounts to the tripod column by means of a panhead adaptor. The unit can be precisely leveled by centralizing the level bubble provided for this purpose. Once positioned, the panhead is locked down, and all rotation and tilt of the platform takes place in the pivots incorporated in the encoder assembly which mounts rigidly to the shoe of the panhead. Adjustable stops are provided to limit horizontal travel in 5-degree increments between 0° and 130°. With stops removed, travel is limited to approximately 350° to prevent winding the cables. Travel in the vertical plane is usually limited to 25° by adjustable stops.

Control Console. The control console is a fully-enclosed, free-standing, shock-mounted assembly housing the control and indicator assemblies, the magnetic tape unit, the digital chart recorder, the stored program processor and the associated central system logic. This unit is illustrated in Figure 3. Storage space is also provided for supplies, records, manuals, etc. Front and rear access is provided for ease of maintenance. Power entry and external interface with the universal device platforms is via cable connectors on a central panel at the rear of the console as illustrated in Figure 4.

The console consists of three 19-inch custom cabinet assemblies within which the equipment is mounted. The basic unit measures 69" x 25 1/4" x 54" (W x D x H), and the writing shelf adds another 19 3/4" to the depth. Weight of the unit is approximately 650 pounds. The cabinet assembly is supported by 12 shock mounts which are in turn assembled to a 3/8" aluminum base plate. This arrangement provides for complete flexibility in the positioning and tie-down of the console in the M-109 shop van or other enclosure.

The left-hand cabinet assembly houses the incremental tape recorder, the system control and single UDP display indicator panel, and the system logic. The tape recorder occupies 12 1/4 inches at the top of the cabinet. Access to printed circuit cards and other vital components of the recorder is provided at the front of the unit by a specially hinged front panel. Tape reels are mounted on hubs with no removable pieces, in accord with standard tape deck practice. The system control and UDP display panel occupies a six-inch space immediately below the recorder.

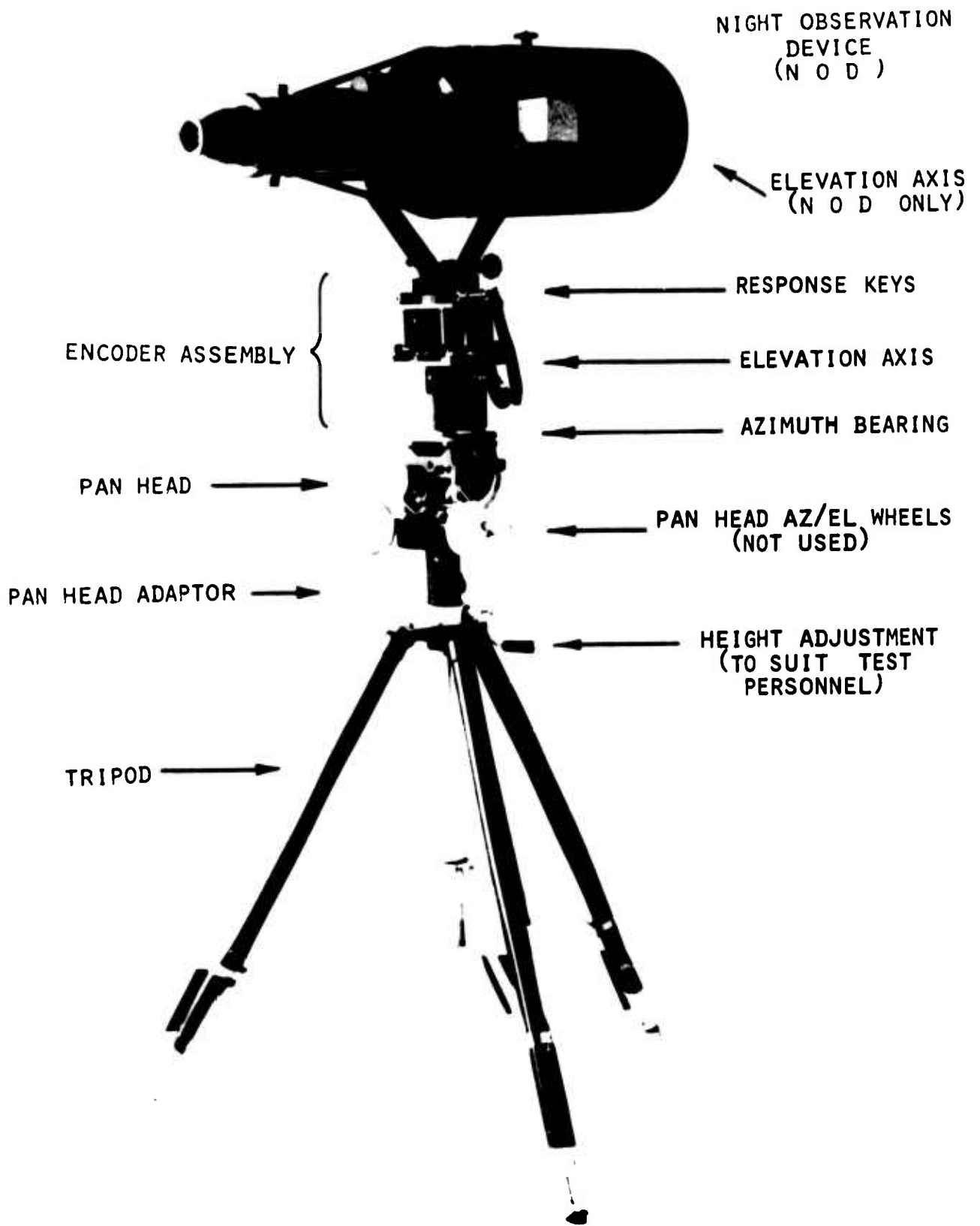

Figure 2. Universal Device Platform

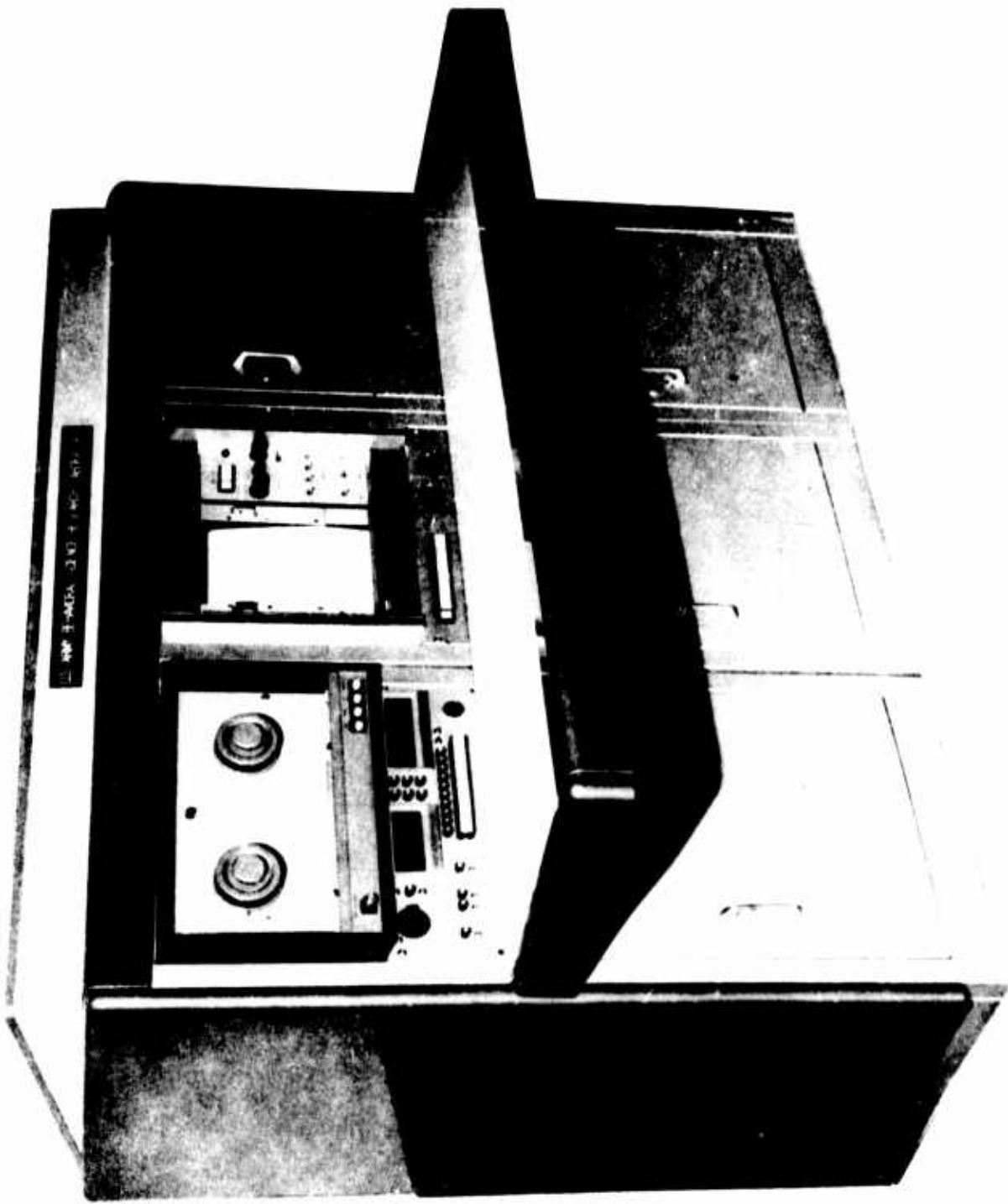

Figure 3. Control Console

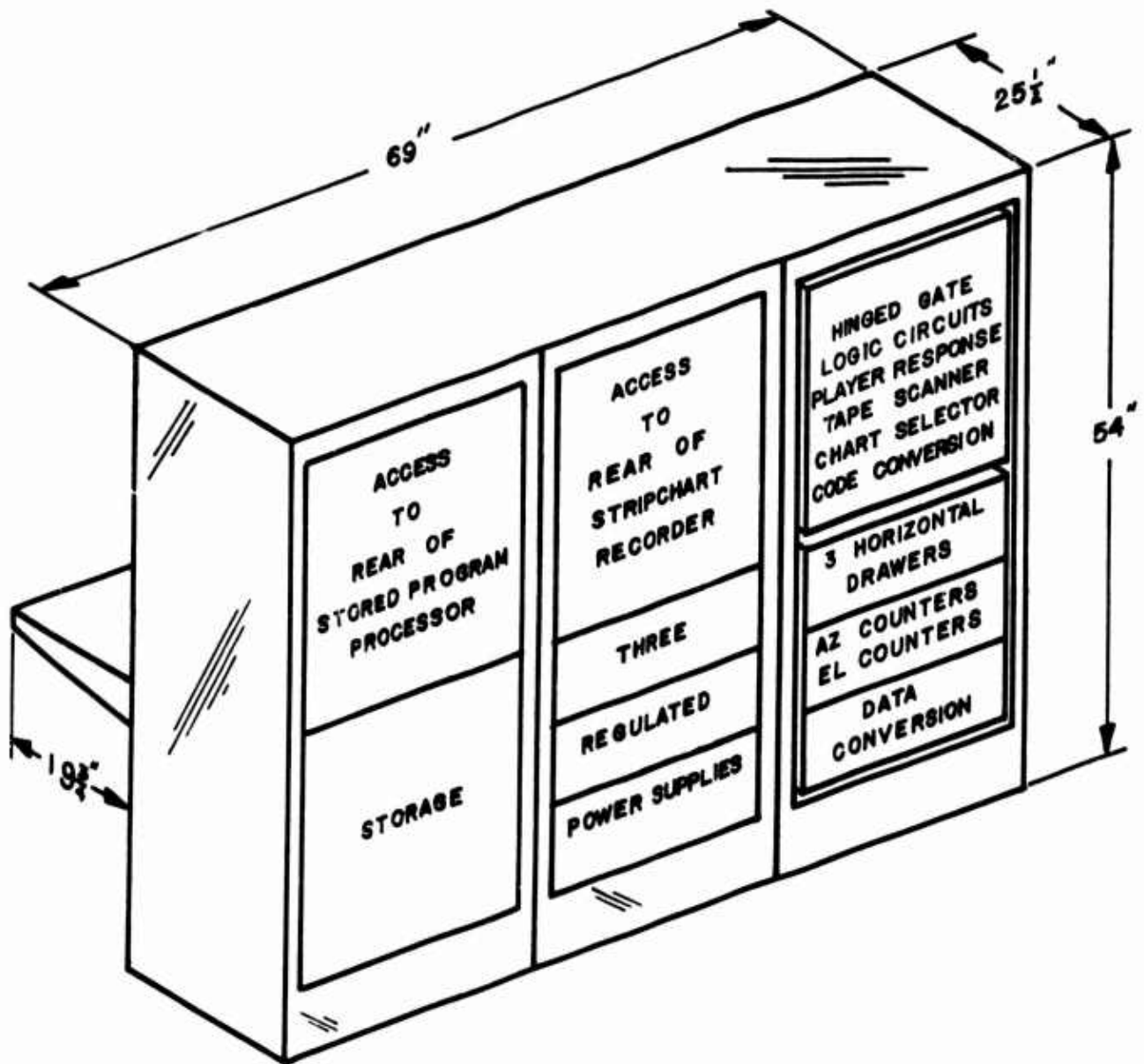

Figure 4. Control Console (Rear view)

At the rear of the left cabinet (Figure 4) are two assemblies which contain the central timing and the system logic. The top unit contains the logic for player response, tape control, chart control, and code conversion. This is a 16-inch hinged assembly, or gate, on which several integrated circuit backplanes are mounted. It also serves as the central tie-point for all assemblies in the console and for interconnecting cable to the UDPs. All interconnection is via plug-in connectors. At the bottom of the left cabinet is a three-shelf drawer assembly containing logic for the azimuth and elevation buffers, counter-select logic, parallel-to-serial converters for the visual display, and chart recorder.

The center cabinet assembly houses the strip chart recorder, its associated control and station selector panel, and the DC power supply for the system. The digital chart recorder occupies the top portion of the cabinet, placing the chart and all controls within easy reach of the operator. Access for maintenance is via front and rear panels. Immediately beneath the recorder, and just above the level of the writing shelf, is the graphic display control panel which contains switches for selecting the player station to be recorded and for entering programmed position data on the recording. Three regulated power supplies which provide all logic and control power for the system are mounted at the rear of the center cabinet.

The right-hand cabinet houses the stored program processor and contains storage space for supplies, manuals, records, and magnetic tapes. All operating controls are within easy reach of the operator, and maintenance access is from the front and rear. The cabinet is equipped with locking doors to resist access. The remaining space in this cabinet is available for expansion.

Teletype Unit. The Teletype Model ASR-33 is a free-standing unit which can be positioned as desired in accordance with available work space. Space required is 22" x 18½" x 32 7/8" (W x D x H), and the unit weighs approximately 56 pounds. The unit interconnects with the control console by a plug-in cable assembly.

The ASR-33 keyboard printer teletype machine is used to enter a program into the stored program processor. This man-machine interface device allows the use of punch paper tape to enter and execute a desired program. The ASR-33 keyboard printer provides a visual indication of entries into the processor and hard-copy printout of transactions transmitted from the processor.

Unclassified

Security Classification

DOCUMENT CONTROL DATA - R & D		
<i>(Security classification of title, body of abstract and indexing annotation must be entered when the overall report is classified)</i>		
1. ORIGINATING ACTIVITY (Corporate author) Behavior and Systems Research Laboratory, OCRD Arlington, Virginia		2a. REPORT SECURITY CLASSIFICATION Unclassified
		2b. GROUP
3. REPORT TITLE HUMAN PERFORMANCE EXPERIMENTATION IN NIGHT OPERATIONS: TECHNOLOGY AND INSTRUMENTATION FOR FIELD RESEARCH		
4. DESCRIPTIVE NOTES (Type of report and inclusive dates)		
5. AUTHOR(S) (First name, middle initial, last name) Aaron Hyman, Jack J. Sternberg, and James H. Banks		
6. REPORT DATE June 1970	7a. TOTAL NO. OF PAGES 29	7b. NO. OF REFS 4
8a. CONTRACT OR GRANT NO.	8b. ORIGINATOR'S REPORT NUMBER(S) Technical Research Note 223	
8c. PROJECT NO. DA R&D Proj. No. 2Q024701A723		
9. Night Operations 4 a-00	9b. OTHER REPORT NO(S) (Any other numbers that may be assigned this report)	
10. DISTRIBUTION STATEMENT This document has been approved for public release and sale; its distribution is unlimited.		
11. SUPPLEMENTARY NOTES		12. SPONSORING MILITARY ACTIVITY Combat Developments Cmd., Ft. Belvoir, Va. U.S. Continental Army Cmd, Ft. Monroe, Va. Office, Chief of Rsch&Devel., Wash.,D.C.
13. ABSTRACT The NIGHT OPERATIONS Program within the Behavior and Systems Research Laboratory is concerned with problems in optimizing human performance in relation to night vision devices and related sensors. In the furtherance of this research, BESRL established a field unit at Fort Ord, California where, with the support of the Combat Developments Command Experimentation Command (CDCEC), studies are being conducted with passive night vision devices. The methods and procedures and experimental techniques which have been developed, as well as some of the research findings, are described in considerable detail in BESRL Technical Research Report 1163. Earlier exploratory experimentation undertaken by the NIGHT OPERATIONS Work Unit in 1967-68 at Fort Benning, Georgia to improve the capabilities of the combat soldier in night operations is discussed in a second BESRL technical research report (TRR 1164). The present publication provides a description and evaluation of the effectiveness of the instrumentation system developed (under DA contract) by Systems Technology Associates following concepts provided by BESRL research scientists. The primary objective in this phase of the research was to develop an instrumentation system, embodying the requirements and essential characteristics for effective and accurate measurement of target detection and search behavior in field testing. The BESRL Night Vision Data Acquisition and Recording System consists essentially of three basic hardware elements: the universal device platforms (UDPs), the control console, and teletypewriter unit. Physical characteristics of the various component units in the system are described in detail. Evaluation of the system established the		

DD FORM 1473 REPLACES DD FORM 1473, 1 JAN 64, WHICH IS OBSOLETE FOR ARMY USE.

Unclassified

Security Classification

14. KEY WORDS	LINK A		LINK B		LINK C	
	ROLE	WT	ROLE	WT	ROLE	WT
*Night Operations research Human performance experimentation *Technology *Instrumentation Field experimentation Night vision devices *Sensors *Sensor systems Universal device platform (UDP) Target acquisition Search data Computer analysis *Data acquisition system Control console Night seeing capability *Experimental techniques *Instrumentation system; concepts Real-time visual displays *Functional subsystems *Data recording system Teletype output Electronic input equipment *System logic Man-machine interface						

13. ABSTRACT continued

following major capabilities: 1) continuous real-time monitoring of operator performance during both training and testing; 2) high degree of reliability, with minimum down time; 3) UDPs accept any passive night vision device--and with minor modifications other devices as well; flexibility and variation in number and type of devices tested are thus "built-in;" 4) high accuracy (0.1°), with the UDP, in determining azimuth and elevation of a device; 5) rapid sampling of device orientation (5 times per second) providing a fine-grained record of search behavior of all operators; 6) recording of target acquisition and search data on magnetic tape for immediate computer analysis with pay-off in reduced data analysis time. The BESRL instrumentation system aids greatly in collection of reliable and valid data in field experimentation. Adaptations of the system have been used by several other agencies, including the Combat Developments Command Experimental Command, the Night Vision Laboratories, and more recently by Project MASSTER.