

RESEARCH TRIANGLE INSTITUTE

Contract No. DAHC 20-68-C-0166

FEBRUARY 1970

OCD Work Unit 1233B

RTI Project OU-400

AD706849

FINAL REPORT
R-OU-400

VENTILATION KIT APPLICATION STUDY

by

M.D. Wright, E.L. Hill & C.T. Sawyer

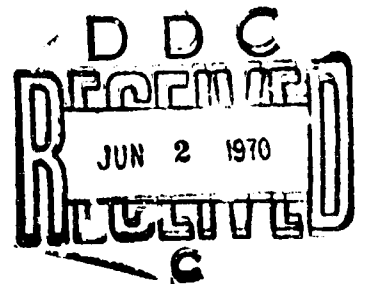

*This document has been approved for public release and sale;
its distribution is unlimited.*

RESEARCH TRIANGLE PARK, NORTH CAROLINA 27709

124

RESEARCH TRIANGLE INSTITUTE
OPERATIONS RESEARCH AND ECONOMICS DIVISION
RESEARCH TRIANGLE PARK, NORTH CAROLINA

OCD REVIEW NOTICE

*This report has been reviewed in the
Office of Civil Defense and approved
for publication. Approval does not
signify that the contents necessarily
reflect the views and policies of the
Office of Civil Defense*

DETACHABLE SUMMARY

FINAL REPORT R-OU-400

Ventilation Kit Application Study

by

M. D. Wright, E. L. Hill & C. T. Sawyer

February 1970

for

OFFICE OF CIVIL DEFENSE
OFFICE OF THE SECRETARY OF THE ARMY
Washington, D. C. 20310

under

Contract No. DAHC20-68-C-0166
OCD Work Unit 1233B

*This document has been approved for public release and sale;
its distribution is unlimited.*

Best Available Copy

DETACHABLE SUMMARY

I. INTRODUCTION

In 1960, the Office of Civil Defense (OCD) initiated the National Fallout Shelter Survey (NFSS) in an effort to locate areas in existing structures which could be used as fallout shelters in the event of a nuclear war. Through this program, as of December 1969, approximately 199,000 buildings containing about 191 million shelter spaces had been surveyed. Shelter spaces were assigned on the basis of 10 square feet per person in those buildings found to have adequate existing ventilation; however, many potentially usable spaces could not be utilized due to deficient existing ventilation. In 1965, it was estimated that approximately 50 million additional spaces could be added to the shelter inventory if these areas could be adequately ventilated.

In an effort to obtain these additional spaces, OCD expanded the NFSS to include a ventilation survey utilizing a 20-inch packaged ventilation kit (PVK). Developments of additional, more efficient ventilation equipment has pointed out a need for updated procedures for defining ventilation systems for shelters. This research concerns the development of these new procedures utilizing existing NFSS data.

II. OBJECTIVES OF THE RESEARCH

The objectives of this research were to develop a methodology for allocating and deploying emergency ventilation equipment to fallout shelters making maximum use of the existing NFSS data; and to test the usefulness and applicability of the methodology and the adequacy of the NFSS data by means of a field test. The equipment considered in this methodology included a 30-inch packaged ventilation kit, a 36-inch Kearny pump and a 72-inch Kearny pump.

III METHODOLOGY DEVELOPMENT

Two alternative plans for developing an allocation and deployment methodology were investigated. The first plan was to investigate possible correlations between the physical characteristics of a shelter and the ventilation equipment needed to ventilate the shelter. This was carried out by defining accurate ventilation plans for a sample of NFSS buildings and then performing analyses to determine if correlations could be found between various physical characteristics of the shelter and the required number and mix of ventilation equipment. To accomplish this task, available NFSS data were obtained for a sample of 189 buildings; however, these data proved to be inadequate to establish a data base of the quality required to perform a meaningful correlation analysis. Therefore, the second alternative for developing the methodology was undertaken.

The second plan for developing an allocation and deployment methodology was centered around six basic configurations into which shelters may be categorized. These configurations were defined by RTI under previous OGD Work Unit 1235A. Development of this methodology consisted of categorizing the aperture configurations for each of the basic shelter configurations and then preparing a standard set of deployment procedures for each category of shelter and apertures. The categorization of apertures was accomplished using the data for the 189 buildings mentioned above.

Use of the methodology consists of performing the following sequence of steps.

- 1) Determine the total usable floor area in the shelter.
- 2) Determine the total air flow required to adequately ventilate the shelter.
- 3) Determine, by a table lookup, the equipment options available to ventilate the shelter.
- 4) Determine if the aperture configuration is sufficient to accommodate at least one of the equipment options.
- 5) If the apertures are not adequate in Step 4, determine the volume of air which can be handled by the apertures and repeat Step 3.
- 6) Determine from the list of shelter and aperture configurations, the one which most nearly approximates the shelter under consideration.
- 7) From the standard set of deployment procedures, define the equipment deployment within the shelter.
- 8) Determine the number of Kearny pumps needed for distributing air in the shelter using the standard deployment procedures as a guide.

IV. METHODOLOGY TESTING

A test of the methodology was accomplished by applying it to a sample of 62 buildings which had previously been surveyed in the NFSS-PVK Survey, and to a sample of 18 buildings which had not previously been surveyed in the NFSS-PVK Survey. The application was done in 3 different ways.

First, a Desk Survey was performed which included defining ventilation plans for each building using only the available NFSS data. Secondly, a Field Survey was made, which consisted of a field visit to each of the buildings to obtain any data not contained in the NFSS which would be useful in defining a ventilation plan, following which new ventilation plans were defined for each building utilizing these additional data. The third application consisted of allocating ventilation equipment to fallout shelters only on the basis of the usable area in the shelter (Usable Area Survey). This third application was performed to determine if this method would be more efficient than the others since it could be accomplished with very little survey costs. The number of shelter spaces obtained and the total cost of each ventilation system were computed for each of the three applications of the methodology.

V. RESULTS

Table I gives the results obtained for the 62 building sample from the NFSS-PVK Survey and from each of the three applications of the methodology. The NFSS-PVK cost figures include equipment costs only, the cost figures for the Desk Survey include equipment costs plus survey costs of \$30 per building, the cost figures for the Field Survey include equipment costs plus survey costs of \$50 per building, and the cost figures for the Usable Area Survey include equipment costs only since the survey costs for this method were assumed to be negligible. The lower cost per space added for the Field Survey was obtained because many openings into the shelter area were found during the field visits which were not contained in the available NFSS data. These additional openings permitted more efficient use to be made of the ventilation equipment and consequently reduced the amount of equipment required. This reduction in the amount of equipment used more than compensated for the added survey costs.

Table I

SUMMARY OF RESULTS FROM 62-BUILDING SURVEYS
(PVK Survey Data Available)

Method	Spaces Added	Total Cost	Cost Per Space Added	Percent Increase in Spaces Added
NFSS-PVK Survey	26,085	\$ 65,609	\$ 2.52	---
New Methodology NFSS Data Only (Desk Survey)	28,798	\$ 38,571	\$ 1.34	10.4
New Methodology NFSS Data and Field Visit (Field Survey)	29,268	\$ 34,856	\$ 1.19	11.5
Usable Shelter Area Method (Usable Area Survey)	28,543	\$ 44,017	\$ 1.54	8.7

Table II gives the results obtained from the three applications of the methodology to the 18 buildings which had not previously been surveyed in the NFSS-PVK Survey. The cost figures contained in this table include equipment costs plus survey costs of \$60 per building in the Desk Survey, \$50 per building in the Field Survey, and zero in the Usable Area Survey. Although a decrease in equipment cost from the Desk Survey to the Field Survey was obtained for this sample of buildings, it was not sufficient to compensate for the increase in survey costs as was the case for the 62 building sample. This is attributed to the fact that most of the 18 buildings were quite small and consequently required very little ventilation equipment in any of the three applications of the methodology.

Table II

SUMMARY OF RESULTS FROM 18-BUILDING SURVEYS

Method	Spaces Added	Total Cost	Cost Per Space Added
New Methodology NFSS Data Only (Desk Survey)	4,850	\$ 5,714	\$ 1.17
New Methodology NFSS Data and Field Visit (Field Survey)	4,850	\$ 5,996	\$ 1.23
Usable Shelter Area Method (Usable Area Survey)	4,667	\$ 6,578	\$ 1.41

VI. CONCLUSIONS

On the basis of the sample of buildings used in this study, it is concluded that a usable ventilation plan can be defined for NFSS shelters using only the available data; however, the most cost-effective application of the methodology is to use it with the available NFSS data supplemented by a field visit.

It is also concluded that the increase in the number of spaces gained using this methodology compared with the NFSS-PVK is a minimum of 10 percent.

RESEARCH TRIANGLE INSTITUTE
OPERATIONS RESEARCH AND ECONOMICS DIVISION
RESEARCH TRIANGLE PARK, NORTH CAROLINA

OCD REVIEW NOTICE

This report has been reviewed in the Office of Civil Defense and approved for publication. Approval does not signify that the contents necessarily reflect the views and policies of the Office of Civil Defense.

FINAL REPORT R-OU-400

Ventilation Kit Application Study

by

M. D. Wright, E. L. Hill & C. T. Sawyer

February 1970

for

OFFICE OF CIVIL DEFENSE
OFFICE OF THE SECRETARY OF THE ARMY
Washington, D. C. 20310

under

Contract No. DAHC20-63-C-0166
OCD Work Unit 1233B

This document has been approved for public release and sale; its distribution is unlimited.

ABSTRACT

This report describes the development and field testing of a methodology for allocating and deploying emergency ventilation equipment to fallout shelters. The methodology developed is based on six basic shelter configurations, determined by the Research Triangle Institute under a previous OCD contract, into which NFSS structures which require additional ventilation may be categorized. Development of the methodology consisted of using NFSS data for buildings and defining a standard set of ventilation equipment deployment plans for each combination of shelter and aperture configuration. The ventilation equipment considered in this methodology included a 30-inch manually-powered Packaged Ventilation Kit, a 36-inch Kearny pump, and a 72-inch Kearny pump.

The methodology was tested by applying it to two sets of real buildings, one set of which had previously been surveyed in the National Fallout Shelter Survey - Packaged Ventilation Kit (NFSS-PVK) Survey and another set which had not. The methodology was first used to define ventilation plans for each of the buildings using only the available NFSS data. Each building was then visited and the ventilation plans were modified on the basis of additional data obtained during the visit. A ventilation plan was also defined for each building solely on the basis of the usable area which each shelter contained. This method involved very little survey effort and was used to evaluate the cost-effectiveness of defining ventilation plans considering all of the available data.

The result of the test applications of the methodology was an increase of about 10 percent in spaces added when compared to the NFSS-PVK Survey. The cost per space added, including survey costs, was \$1.34 using NFSS data only, \$1.19 using NFSS data and including a field visit, and \$1.54 using the usable area in each facility as the allocation criterion and assuming zero survey costs. The cost per space added for equipment alone in the NFSS-PVK Survey was \$2.52.

The test applications revealed that a usable ventilation plan can be defined using available NFSS data only, but that a more cost-effective application of the methodology is to use the NFSS data supplemented by a field visit to obtain additional data.

TABLE OF CONTENTS

	<u>Page</u>
ABSTRACT	ii
LIST OF TABLES	iv
I. INTRODUCTION	1
II. METHODOLOGY DEVELOPMENT	4
A. Approach	4
B. Correlation Method	4
C. Categorization Method	7
III. METHODOLOGY TESTING.	10
A. Scope of Survey.	10
B. Buildings with PVK Survey Data Available	10
C. Buildings Without PVK Survey Data Available.	12
D. Ventilation Equipment Cost Data	13
E. Results.	14
F. Conclusions.	21
IV. RECOMMENDATIONS.	22
A. Additional Data.	22
B. Additional Research.	22
APPENDIX A: Description of NFSS Data.	A-1
APPENDIX B: Ventilation Kit Allocation and Deployment Methodology.	B-1
APPENDIX C: Examples of Methodology Application	C-1

LIST OF TABLES

<u>Table</u>		<u>Page</u>
I	Equipment Costs	13
II	Survey Results for Buildings with PVK Survey Data Available.	15
III	Summary of Results from 62-Building Surveys	17
IV	Survey Results for Buildings Without PVK Survey Data Available.	19
V	Summary of Results from 18-Building Surveys	20
B-I	Equipment Options for Given Air Flow Requirements	B-5
B-II	Combinations of Type I and Type II Kearny Pumps for Given Air Flow Requirements (CFM)	B-7

Ventilation Kit Application Study

I. INTRODUCTION

In 1960, the Office of Civil Defense (OCD) initiated a program to identify protection for the population from nuclear fallout radiation in the event of a nuclear war. One of the major undertakings of this program has been the National Fallout Shelter Survey (NFSS). The purpose of the NFSS has been to identify shelter areas in existing structures which would provide a protection factor of 40 or more. As of December 1969, approximately 199,000 individual buildings containing about 191 million spaces affording a protection factor of 40 or better have been identified [Ref. 1].

The shelter capacity of buildings having existing ventilation sufficient to provide at least 3 cubic feet per minute (CFM) of fresh air per person was calculated on the basis of 10 square feet per person. The capacity of those shelters having less than 3 CFM per person was computed on a volume basis ranging from 65 cubic feet per person for a ventilation rate of 3 CFM per person up to 500 cubic feet per person for a ventilation rate of 0.5 CFM per person. In NFSS Phase 2, computations were made to determine the additional spaces which would be available if all shelters found deficient on the basis of ventilation could be adequately ventilated and, consequently, their capacities determined on the basis of 10 square feet per person. As of 1965, this resulted in an estimate that approximately 50 million shelter spaces with a PF of 40 or better could be added to the national inventory of spaces through ventilation improvements [Ref. 2].

This number of spaces was considered sufficient to warrant studies into possible means of providing inexpensive emergency ventilation systems. Consequently, OCD developed the 20-inch Packaged Ventilation Kit (PVK) [Ref. 3] and prepared instructions and procedures for implementing the PVK Survey as an integral part of the NFSS [Ref. 4].

Continued OCD sponsored research relevant to fallout shelter ventilation has included investigations of additional sizes and types of fan-type ventilators and has pointed out the need for an air distributional device for use in shelters in conjunction with equipment to supply air to the shelters.

The objectives of the research reported herein were to develop a methodology for allocating and deploying the latest emergency ventilation equipment to fallout shelters utilizing existing NFSS data as extensively as possible, and to evaluate the usefulness and applicability of the developed methodology through a field test.

The work statement from OCD Work Unit 1233B, Contract No. DAHC 20-68-C-0166, reads as follows:

"From the current NFSS inventory information or selected portions of it, identify a single descriptor or group of descriptors which (a) when coupled with specific ventilation equipment characteristics and ventilation rate requirements will identify the equipment which will best ventilate any given facility and the preferred equipment deployment; (b) develop a technology which utilizes the identified descriptor(s), equipment characteristics, and ventilation rate requirements to produce specific ventilation equipment allocation levels for the NFSS inventory or selected portions of it."

Apply the developed technology to a small to moderate size Standard Metropolitan Statistical Area (SMSA). Identify and compare the shelter spaces determined in this application to the shelter spaces found in the National Fallout Shelter Survey (NFSS). Evaluate the usefulness of the technology in developing additional shelter space.

The equipment considered in developing this methodology included a 30-inch packaged ventilation kit [Ref. 5] (manually powered through a bicycle drive apparatus) and a device called a Kearny pump [Ref. 6], which operates on the principle of a punkah. The Kearny pump is capable of moving large quantities of air under low pressure heads with low power input, and can be used to distribute air inside a shelter or to supply air to a shelter. These items of equipment are shown in Figures 1 and 2. The NFSS survey data which were available to describe ventilation characteristics of shelters are described in Appendix A.

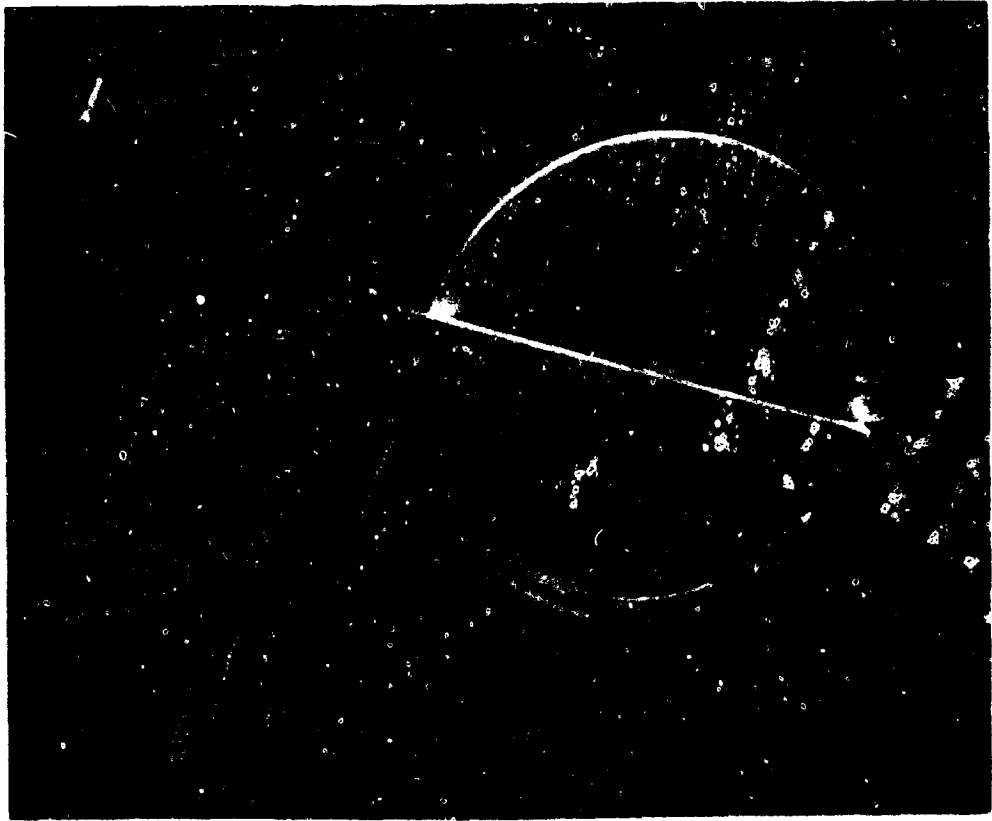

Fig. 1. 30-inch Packaged Ventilation Kit.

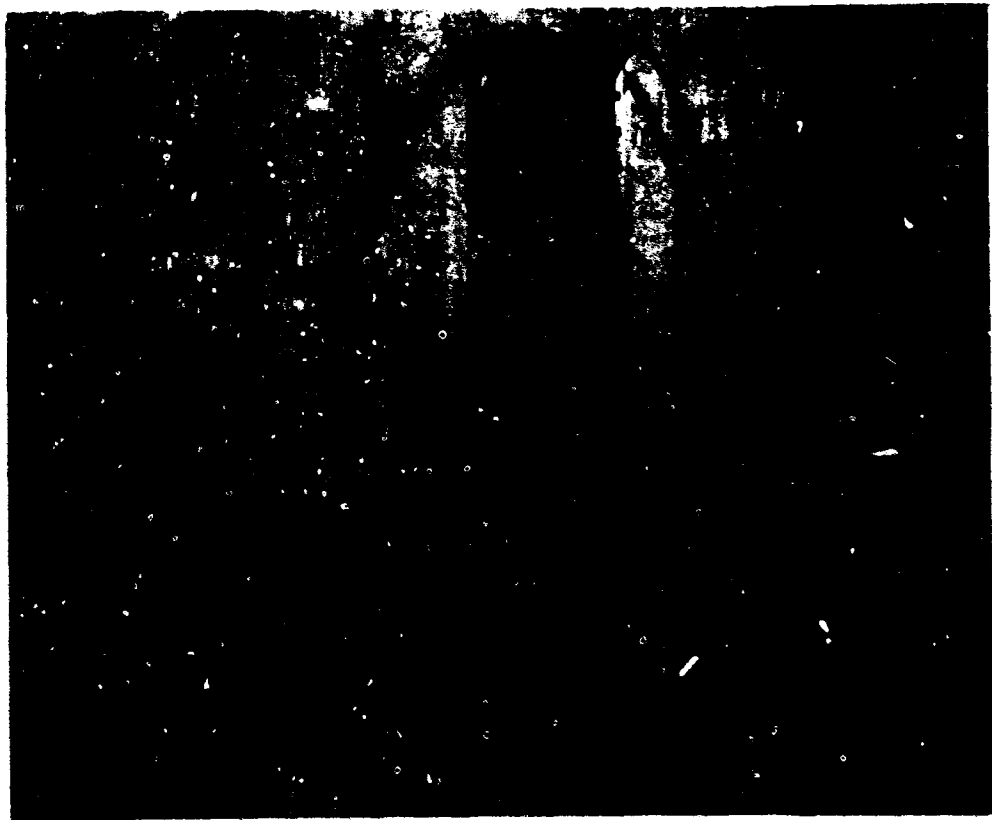

Fig. 2. Kearny Pump.

II. METHODOLOGY DEVELOPMENT

A. Approach

Investigations were made into two alternative approaches for developing the ventilation equipment allocation and deployment methodology. The first approach was to define ventilation plans for a sample of NFSS buildings requiring additional ventilation and to determine if a correlation exists between the physical characteristics of shelters as reported in the NFSS and their ventilation equipment requirements.

The second approach, to be investigated if the first approach proved to be infeasible, was to define basic shelter configurations into which all shelters could be classed and to develop a methodology for each configuration.

Development of the methodology was accomplished with the following considerations:

- 1) Maximize shelter area usage through adequate distribution of fresh air over the maximum amount of shelter area.
- 2) Minimize duct lengths through careful selection of ventilator placement within the shelter and by using the ventilators in supply configurations when possible.
- 3) Minimize costs by maximizing the efficiency of the ventilation systems and by keeping the methodology simple to apply.
- 4) Maximize use of available NFSS data to minimize or eliminate field visits to the facilities.

B. Correlation Method

NFSS data for a sample of real buildings, which had been identified as containing shelter areas requiring additional ventilation, were obtained for analysis to determine if there is a correlation between shelter characteristics reported in the NFSS and the shelter's ventilation requirements. Upon request, the Army Corp of Engineers (through the Joint Civil Defense Support Group) provided completed PVK forms for a sample of 189 buildings. The buildings were of various sizes and shapes and represented six of the eight OCD regions. After these data were obtained, NFSS Phase 1 and Phase 2 data for each of the 189 buildings were obtained from the master files maintained on magnetic tape at the National Civil Defense Computer Facility (NCDCF) at Olney, Maryland.

Following are some of the more pertinent tabulations of data derived from the sample of 189 buildings:

- 1) NFSS Phase 1 data were unavailable for thirty (30) of the 189 buildings.

- 2) Ten (10) buildings had aperture sill heights reported in Phase 2 but had no aperture percentage reported in Phase 1.
 - a) Three (3) had apertures indicated on the PVK Survey sketch.
 - b) Seven (7) had no apertures indicated on the PVK Survey sketch.
- 3) Eighty (80) buildings had apertures indicated in both Phase 1 and Phase 2.
 - a) Thirty-three (33) had apertures indicated on the PVK Survey sketch.
 - b) Forty-seven (47) had no apertures indicated on the PVK Survey sketch.
- 4) Sixty (60) buildings had no apertures reported in Phase 1, Phase 2, or on the PVK Survey sketch.
- 5) Nine (9) buildings had no apertures reported in either Phase 1 or Phase 2 but did show apertures on the PVK Survey sketch.

Of the 189 buildings, 93 showed agreement between Phase 1, Phase 2, and PVK Survey aperture data. These were the 60 buildings with no apertures in either data source and the 33 buildings with apertures in all three data sources. Of the 33 buildings with apertures reported in all three sources, 8 of them included the dimensions of each aperture. These 8 buildings were the only ones for which ventilation plans could be defined with a high degree of confidence using only exterior wall apertures as the means of air supply and exhaust. When stairways and elevator shafts were considered as means of supplying and/or exhausting air, ventilation plans could be defined for a larger number of the buildings, although it was usually necessary to make minor assumptions regarding the configuration of the story or stories adjacent to the shelter story and the availability of air from these stories. After a careful study of the data for each building, it was concluded that acceptable ventilation plans could be defined for a total of 62 of the 189 buildings. Ventilation plans could not be defined for the remaining 127 buildings for the following reasons:

1) No Phase 1 data available.

Phase 1 data could not be found in the NCDCF files for 30 of the 189 buildings. It would be possible to define ventilation plans for some of these buildings using only the data on the PVK Survey sketch. However, because of the frequency of disparities between Phase 1 data and PVK Survey sketch data for those buildings with both sources of data available, these buildings were not considered.

2) Apertures reported in Phase 1 data but the aperture distribution relative to partitions not shown on the sketch.

Forty (40) buildings were eliminated from consideration for this reason. Most of these shelters consisted of several rooms and had a

significant amount of apertures reported (>20%). The room configurations were such that a knowledge of the distribution of apertures would be necessary to define an effective ventilation system.

3) Insufficient data and/or clarity of sketch.

Forty-six (46) buildings were eliminated due to deficiencies in PVK sketch data. Most buildings were eliminated because the sketch showed no openings between rooms in the shelter. The remaining ones were due to poor reproduction which made it impossible to determine the location of partitions and openings.

4) Major disagreement between NFSS Phases 1 and 2 file data and PVK sketch.

Eleven (11) buildings were eliminated because of discrepancies between basic NFSS data and data reported on the PVK Survey sketch. The disagreements were either that no apertures were reported in Phase 1 or Phase 2 but apertures were indicated on the sketch, or that the building side for which apertures were reported in Phase 1 was different from the side on which apertures were indicated on the sketch.

In order to determine a possible relationship between shelter characteristics and ventilation equipment, it would be necessary to have a data base consisting of efficient ventilation plans designed with a high degree of confidence. The study of the data for the 189 buildings indicated that the NFSS data base does not contain "descriptors" of building characteristics which would enable an adequate definition of required ventilation equipment to be made. In view of this, the second alternative approach for developing an allocation and deployment methodology was selected, and is discussed in the following section.

C. Categorization Method

This approach for developing a ventilation equipment allocation and deployment methodology had the objective of describing a standardized set of ventilator deployment plans for basic shelter configurations into which shelters could be classed. The six shelter configurations illustrated in Figure 3 were used in the study; these configurations were originally identified under OCD Work Unit 1235A [Ref. 2].

The first step in the development of the methodology was to identify the aperture configurations that might exist for each of the basic shelter configurations. This was accomplished through an analysis of the data for the 189 buildings described in the previous section. The number of configurations of apertures found for each shelter configuration was quite large; however, when considered only as to their use in a ventilation system, the number of configuration categories was reduced to a usable value. Ventilator deployment plans were then defined for each category of shelter and aperture configuration determined. Instructions describing the procedures to follow in defining a ventilation system for each fallout shelter configuration were developed and are included as Appendix B. Application of the methodology described in detail in Appendix B to a specific building requires the following sequence of steps:

- 1) Determine usable floor area. The total usable floor area in the shelter is determined from the data contained on the PVK Survey form, if available, or by summing "existing spaces" and "added vent spaces" listed on the Phase 2 Data Collection Form (DCF). Usable area is defined as the total floor area less the area occupied by machinery, equipment, or partitions which cannot be moved out of the shelter area.
- 2) Determine air flow required. This step is accomplished by dividing the usable floor area (square feet) determined in the previous step by 10 to determine the number of available shelter spaces. The number of spaces is then multiplied by the required air flow rate per shelter occupant for the particular geographic location of the shelter [Ref. 4].
- 3) Determine equipment options. Tables B-1 and B-2 of Appendix B were developed to give the numbers of each type of equipment that are required to deliver the quantity of air determined in Step 3. Karny pumps are selected for use in all shelters where the aperture configuration permits, otherwise, the PVK ventilators are used.

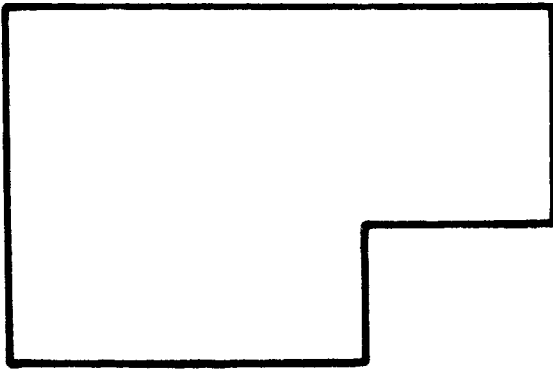

Single Room

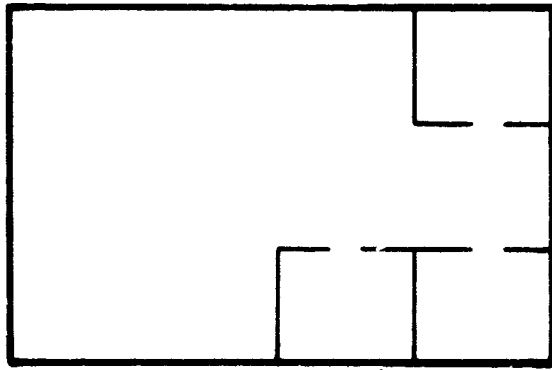

Large Area with Small Adjoining Rooms

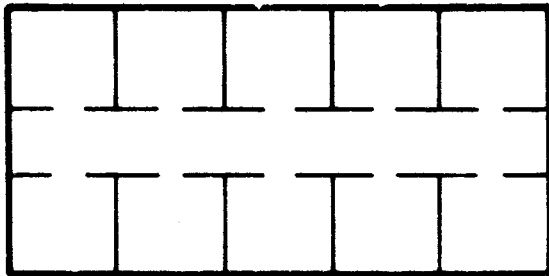

Corridor with Rooms off Corridor

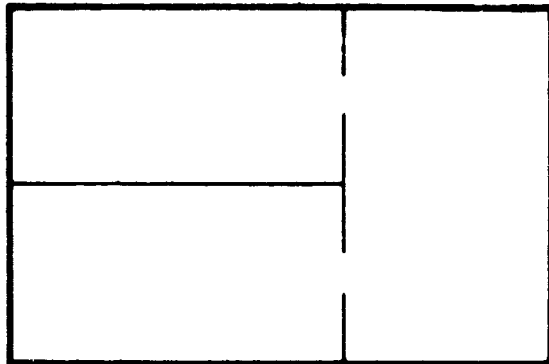

Partitioned into Rooms of Comparable Size

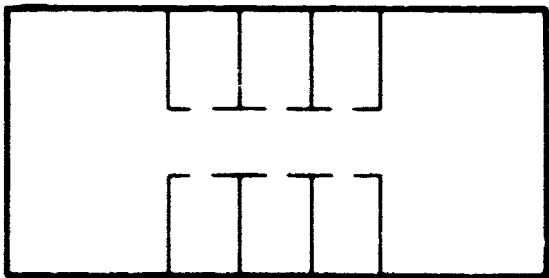

Corridor (With Rooms Off It) Joining Two Large Areas

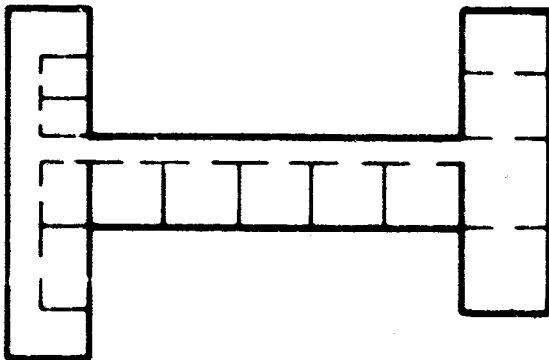

Complex Configuration

Fig. 3. Six Basic Shelter Configurations.

- 4) Determine aperture adequacy. The area and configuration of openings into the shelter are checked against the criteria given in the methodology to determine if they are adequate to permit the use of the required number of Kearny pumps or PVK's.
- 5) Adjust air flow if necessary. If it is found in Step 4 that the apertures are not adequate, the volume of air which can be handled by the existing apertures is determined and Step 3 is repeated.
- 6) Choose shelter and aperture configuration. From the list of shelter and aperture configurations given in the methodology, the configuration which most nearly approximates the configuration of the particular shelter being considered is chosen.
- 7) Define equipment deployment. The methodology contains a separate paragraph describing the deployment procedure to follow for each configuration of shelter and apertures. Schematic diagrams also illustrate possible plans of deploying ventilation equipment for that particular configuration. Using this information as a guide, an equipment deployment plan is defined for the shelter being considered.
- 8) Determine number of Kearny pumps needed. The number of Kearny pumps needed to distribute air inside the shelter is determined using the deployment procedures given in the methodology for guidance. This includes the Kearny pumps needed to supply air to dead-end rooms and those needed to distribute air over areas of the shelter which are not in the normal flow path of the ventilating air passing through the shelter.

III. METHODOLOGY TESTING

A. Scope of Survey

In order to evaluate the methodology and to determine the adequacy of previously collected NFSS data for use in the methodology, a field test was performed. Durham, North Carolina and Greensboro - High Point, North Carolina SMSA's were selected as the areas for the field test. Seven buildings in the Durham SMSA and 55 buildings in the Greensboro - High Point SMSA had been surveyed in the PVK Survey.

The test of the methodology consisted of applying it to two sets of buildings. The first set consisted of the 62 buildings for which the PVK Survey had been performed, and the second set consisted of 18 buildings in Durham for which no PVK Survey had been performed.

B. Buildings with PVK Survey Data Available

All available data collected in the NFSS for the 62 buildings which were listed in the PVK Survey were obtained from the Charleston, South Carolina office of the Naval Facilities Engineering Command. These data included the NFSS Phase 1 and Phase 2 data collection forms, shelter marking sketches, and PVK Survey forms for each building. Utilizing these data, the methodology was used to define ventilation plans for each of the 62 buildings in three ways. Each of these is described below.

1. Desk Survey

Ventilation plans were defined for each building using only the available NFSS data and without visiting the building. For some of the buildings, it was necessary to make assumptions concerning the size of apertures and the configuration of stairways; however, the number of assumptions were kept to a minimum by discounting questionable data if a ventilation plan could be developed without using them. The number of shelter spaces adequately ventilated in each building was determined and the ventilation equipment costs were computed. The labor cost of performing a survey of this type was estimated to be \$30 per building.

2. Field Survey

After ventilation plans had been defined in the Desk Survey, as described above, a visit was made to each of the buildings to check the adequacy of the ventilation plans and to obtain any additional information which could be utilized to increase the efficiency of the ventilation systems. These visits yielded a great deal of information about apertures in basement areas which are not relevant to radiation shielding and consequently were not

considered in any of the earlier surveys. These data included such items as ventilation shafts, pipe shafts, ventilation ducts to the outside, exhaust fan openings, and coal chutes. Following the field visit, new ventilation plans were devised for each building utilizing the additional data obtained during the visit. The number of spaces adequately ventilated with the new ventilation plan was determined and the ventilation equipment costs for each building were computed. The total labor cost of performing a survey of this type was estimated to be \$50. This included obtaining the NFSS data, obtaining supplemental data through a site visit, and preparing the ventilation plans.

3. Usable Area Survey

A simplified method of allocating ventilation equipment to fallout shelters was devised in which usable shelter area was the only item of information considered. This procedure could easily be performed by a computer and consequently would keep survey costs to a minimum. This allocation and deployment method consisted of allocating 1 PVK ventilator for each 2100 square feet of usable shelter floor area and 1 Kearny pump for each 1000 square feet of usable floor area. The ratio for allocating PVK ventilators was determined using the capacity of a ventilator when used with 150 feet of duct, and using a zonal ventilation rate requirement of 15 CFM per occupant, which is the zonal ventilation rate requirement for the Greensboro - High Point and Durham SMSA's. A duct length of 150 feet was selected on the basis of the earlier allocations which indicated that all but one of the 62 shelters could be ventilated with 150 feet of duct, or less. The allocation of Kearny pumps at the rate of 1 per 1000 square feet of usable floor area was based on research performed by the Protective Structures Development Center, Fort Belvoir, Virginia [Ref. 7]. Results of this research imply that one 36-inch Kearny pump is capable of properly mixing air over a floor area of approximately 1000 square feet. In the allocation of ventilation equipment, if a fraction of a ventilator was required, the number was rounded up if the fraction was greater than or equal to one-tenth and down if the fraction was less than one-tenth. After the allocations were made for each shelter, the actual NFSS data for each building were used to determine the number of spaces which could be adequately ventilated with the equipment allocated. The costs of the ventilation equipment were then computed for each building; labor costs were assumed to be zero.

Appendix C contains results for selected buildings obtained from the Desk Survey and the Field Survey.

C. Buildings Without PVK Survey Data Available

The PVK Survey was not conducted in some Standard Locations where a sufficient number of shelter spaces were considered to have already been identified; i.e., "surplus" shelter areas. Therefore, many basement shelters exist which have their capacities determined on a volume basis. Due to the significantly greater protection offered by basement shelters relative to above-ground shelters from the effects of both blast and radiation, it is desirable to maximize the utilization of basement shelter areas. In order to determine if the methodology can be applied to buildings without the benefit of the PVK Survey data, a sample of 18 such buildings in the Durham SMSA were selected for study. These buildings had been indicated on the NFSS Phase 2 DCF as having areas in which additional spaces could be obtained through ventilation improvements.

These 18 buildings were analyzed in the same way as the 62 buildings described in the preceding paragraphs. That is, the methodology was used to define ventilation plans for each of the 18 buildings by a Desk Survey, a Field Survey, and a Usable Area Survey.

The data available for these buildings were the same as for the 62-building sample except for the absence of PVK Survey data. The shelter marking sketch was used to determine the interior room configuration of the shelter in the absence of the PVK sketch. Most of these sketches did not show openings between rooms and it was therefore necessary to assume locations for these openings.

Ventilation plans were defined in a Desk Survey for each building on the basis of these assumptions and the number of spaces gained and the equipment costs were computed.

Visits were then made to each building and new ventilation plans were defined for each building incorporating additional data obtained during the site visits. Spaces gained and costs were then computed for these ventilation plans.

Ventilation equipment was then allocated on the basis of the usable area in each shelter using the same ratios used in the 62-building sample. The NFSS survey data were then used to determine the number of spaces gained using the equipment allocated in this manner and the equipment costs for this method were computed. Since these buildings did not have a PVK Survey form available, the usable area in each building was obtained by summing the existing spaces and the spaces which could be added through ventilation improvements listed on the NFSS Phase 2 Data Collection Form, and multiplying this sum by 10 square feet to obtain the total usable area in the building.

Labor costs per building for this analysis were the same as those assumed in the surveys described in Section III. B.; i.e., Desk Survey, \$30; Field Survey, \$50; and Usable Area Survey, \$0.

D. Ventilation Equipment Cost Data

The equipment costs used in this analysis are listed below in Table I. It should be noted that since this analysis was completed, new cost estimates have been received for the 30-inch PVK and the Kearny pumps. The new cost estimates are \$131 for the 30-inch PVK and \$78 for a 72-inch Kearny pump, which can be used as a single 72-inch Kearny pump or can be broken down and used as two 36-inch Kearny pumps.

Table I

EQUIPMENT COSTS

Equipment	Cost
20-inch PVK (1-man)	\$ 154
20-inch PVK (2-man)	\$ 219
30-inch PVK (1-man)	\$ 109
36-inch Kearny pump	\$ 39
72-inch Kearny pump	\$ 39

E. Results

1. Buildings with PVK Survey Data Available

Table II shows the information listed in the NFSS-PVK data files for the 62-building sample and lists the results of each of the three applications of the methodology as described in Section III. B. NFSS-PVK information given in each building is the Standard Location and Facility numbers, the existing shelter spaces before ventilation improvements, and the results of the NFSS-PVK Survey. The results for each methodology application include the numbers of each type of ventilation equipment allocated, the number of spaces added, and the total cost of ventilation for each building.

During Phase 2 of the NFSS, buildings with sufficient existing ventilation to provide at least 3 CFM per occupant to the shelter had spaces allocated on the basis of 10 square feet per space; however, if the existing ventilation was less than the area's zonal requirement (15 CFM per occupant for the Durham and Greensboro - High Point SMSA's), a PVK Survey was also performed. In these cases, the number of spaces added through ventilation improvements was listed as zero. Six of the buildings came under this category and contained a total of 5,890 existing shelter spaces. Another two buildings were listed as having no spaces added in the NFSS-PVK Survey because none of the individual rooms contained as many as 50 shelter spaces. These two buildings contained a total of 240 spaces. Thus, a total of eight buildings were listed as having no shelter spaces added even though additional ventilation was required.

Of the 56 buildings which could have spaces added, Field Survey results in Table II indicate that three buildings have less than 50 spaces added, ten buildings have between 50 and 99 spaces added, twenty-five buildings have between 100 and 499 spaces added, twelve buildings have between 500 and 1000 spaces added, and six buildings have more than 1000 spaces added. The number of spaces added per building ranges from 19 to a maximum of 5,610; however, the majority of the buildings (66 percent) have from 100 to 1000 spaces added.

The largest increase in spaces added occurs in Building Number 10 in which the spaces added increase from 1,396 in the NFSS-PVK Survey to 2,550 in all applications of the new methodology. Other buildings which show quite significant increases in spaces added are Building Numbers 5, 7, 14, 22, and 33.

Table II
 SURVEY RESULTS FOR BUILDINGS WITH PVK SURVEY DATA AVAILABLE
 (62 Buildings)

Building Number	Standard Location	Facility Number	Ventilation Configuration Code	National Fallout Shelter Survey				Allocation and Deployment Methodology											
				Existing Shelter Spaces	Added Shelter Spaces	Ventilation Equipment	Total Cost	Desk Survey			Field Survey			Nucleic Area Survey					
								Added Shelter Spaces	Ventilation Equipment	Total Cost	Added Shelter Spaces	Ventilation Equipment	Total Cost	Added Shelter Spaces	Ventilation Equipment	Total Cost			
1	35410018	00036	II-2	343	424	6,0	\$ 924	499	4,8,0	\$ 750	409	4,8,0	\$ 770	499	4,8,0	\$ 730			
2	35410010	00041	I-A-3	57	135	2,1	527	135	3,2,0	212	135	1,3,0	271	135	1,3,0	221			
3	35410010	00034	VI	484	1,777	8,11	3,681	1,000	15,12,0	2,050	1,000	15,12,0	2,070	1,000	15,12,0	2,000			
4	35410008	00353	I-A-2	80	352	2,1	537	352	2,4,0	394	352	2,1,1	336	352	2,4,0	364			
5	35410008	00306	VI	150	357	5,0	795	475	4,10,0	836	475	3,3,1	596	475	4,7,0	609			
6	35410009	00416	II-A-3b	603	267	0,5	1,095	270	4,7,0	719	200	3,7,0	843	200	3,9,0	671			
7	35410009	00414	IV-A-3	89	248	3,1	696	347	3,3,1	490	342	2,2,1	375	342	3,5,0	405			
8	35410009	00402	III-A-2	1,389	213	3,8	2,229	244	6,1,0	693	244	6,2,0	752	244	8,17,0	1,405			
9	35410009	00421	VI	517	1,118	6,9	2,825	1,114	7,12,0	1,236	1,114	7,12,0	1,246	1,114	9,10,0	1,630			
10	35410036	02755	II-A-3C	302	1,396	5,18	4,737	2,350	15,0,0	1,990	2,350	10,1,0	1,129	2,350	14,29,0	2,367			
11	35410036	02754	III-C-3	112	751	2,6	1,632	751	6,0,0	654	751	6,0,0	674	751	5,9,0	671			
12	35410036	02758	I-A-2	328	732	0,7	1,733	732	4,4,0	602	732	4,0,0	466	732	3,11,0	949			
13	35410036	02757	VI	280	489	7,1	1,532	545	4,8,0	750	545	4,2,0	544	545	4,9,0	767			
14	35410055	02701	IV-A-3	71	109	2,0	318	224	2,7,0	355	224	2,3,2	323	224	2,3,0	325			
15	35410052	02554	III-B-2	30	134	2,0	316	83	1,1,0	173	153	1,1,0	70	153	1,2,0	182			
16	35410054	02655	IV-A-3	90	52	0,1	219	91	1,5,0	329	95	1,3,0	271	96	1,2,0	182			
17	35410057	02801	IV-A-3	91	488	7,0	1,113	522	3,4,2	576	522	3,3,0	479	522	3,7,0	595			
18	35410056	02739	VI	82	376	5,0	725	301	3,2,0	420	301	2,3,0	371	301	3,5,0	507			
19	35410049	02406	I-A-5	54	120	1,1	378	120	1,1,0	173	120	1,1,0	193	120	1,2,0	182			
20	35410017	00801	I-B-2C	90	0	1,0	159	0	0,1,0	69	0	0,1,0	89	0	1,1,0	143			
21	35410010	00456	II-A-5	130	481	0,4	876	371	3,9,0	693	371	3,9,0	713	327	4,7,0	609			
22	35410010	00457	VI	332	437	4,2	1,074	639	5,6,0	784	639	4,3,0	583	533	5,0,0	910			
23	35410010	00453	III-A-3d	28	186	1,1	278	186	2,2,0	316	186	2,2,0	336	175	1,3,0	221			
24	35410007	00302	III-A-1	61	97	2,0	318	97	0,3,1	186	90	0,3,1	206	90	1,2,0	182			
25	35410029	01402	III-C-2	84	231	3,7	696	243	2,2,0	316	243	2,1,0	297	243	2,4,0	364			
26	35410018	00033	II-A-3d	42	56	2,1	537	84	1,2,0	212	94	1,1,0	193	94	1,2,0	182			
27	35410008	00371	I-B-1e	493	889	1,8	1,911	889	8,0,0	842	889	6,0,0	674	889	7,14,0	1,274			
28	35410008	00351	I-A-3	25	30	1,0	159	30	0,2,0	100	30	0,2,0	120	30	0,1,0	142			
29	35410009	00432	II-A-3a	225	1,751	0,15	3,205	1,751	4,10,0	1,252	1,751	8,0,0	882	1,752	10,20,0	1,630			
30	35410009	00417	I-A-2	126	546	0,5	1,095	546	3,6,0	576	546	3,6,0	596	546	4,7,0	609			
31	35410009	00415	II-A-2	263	556	1,5	1,254	632	4,2,0	524	632	4,2,0	544	632	5,9,0	671			
32	35410009	00424	V-A-5	52	677	6,1	1,173	725	6,1,0	693	725	6,1,0	713	486	4,9,0	767			
33	35410009	00412	IV-A-3	704	78	4,0	636	249	3,30,0	1,512	249	1,30,0	1,532	0	4,7,0	609			
34	35410009	00418	I-A-5	27	81	1,0	159	81	1,1,0	173	81	1,0,0	154	81	1,1,0	143			
35	35410009	00410	IV-A-3	154	335	3,2	915	385	2,3,2	433	385	2,4,2	570	333	3,5,0	507			
36	35410009	00428	VI	78	98	1,1	378	98	2,0,0	230	98	2,0,0	250	82	1,2,0	182			
37	35410009	00434	II-A-2	112	248	3,0	477	278	2,4,0	394	278	2,4,0	414	278	2,4,0	376			
38	35410009	00423	IV-A-3	216	342	6,0	954	342	3,3,0	450	342	2,9,0	250	342	3,6,0	544			
39	35410014	00655	III-A-3e	55	163	3,0	477	186	2,3,0	355	186	2,3,0	375	186	2,3,0	323			
40	35410033	01101	I-B-2d	86	130	3,0	477	130	2,1,0	277	130	0,0,1	89	130	1,3,0	221			
41	35410032	01553	I-B-1e	53	86	0,1	219	111	1,0,1	172	111	1,0,1	193	111	1,2,0	182			
42	35410001	00003	III-B-2	27	0	0,0	0	89	1,3,0	251	89	0,0,1	120	89	1,2,0	182			
43	35410001	00005	I-C-1	9	44	1,0	159	44	0,0,1	69	44	0,0,1	89	44	1,1,0	143			
44	35410001	00001	I-A-4	273	294	2,2	726	294	1,5,0	537	294	2,1,0	297	294	3,6,0	544			
45	35410003	00107	IV-A-3	380	327	6,1	1,173	227	4,4,0	680	407	3,0,0	362	407	6,0,0	720			
46	35410011	00523	II-A-2	68	189	2,1	537	196	2,5,0	433	214	1,1,0	193	214	2,3,0	323			
47	35410011	00525	I-C-4	318	1,021	9,5	2,526	1,021	9,0,0	966	1,021	5,0,0	570	1,021	7,14,0	1,274			
48	35410011	00528	I-A-5	76	19	1,0	159	19	1,1,0	173	19	1,1,0	193	19	1,1,0	143			
49	35410011	00506	IV-A-2	39	0	0,0	0	85	1,4,0	290	85	1,0,0	154	85	1,2,0	182			
50	35410028	01453	I-B-2a	642	5,610	0,20	4,300	5,610	22,12,0	2,786	5,610	22,0,0	2,630	5,610	30,03,0	5,377			
51	35410015	00702	II-A-3d	117	310	4,1	855	523	3,5,0	537	565	3,2,0	440	565	4,7,0	609			
52	35410057	02806	II-A-3d	29	120	2,0	318	153	1,1,0	251	170	1,1,0	193	170	1,2,0	182			
53	35410056	02753	IV-A-3	135	529	4,3	1,393	544	3,10,3	849	574	3,0,4	630	676	5,9,0	671			
54	35410056	02754	I-A-5	18	53	2,0	318	53	1,1,0	173	53	1,0,0	154	53	1,1,0	143			
55	35410056	02656	I-A-5	65	180	0,2	430	180	2,0,0	230	180	1,0,0	154	180	2,3,0	323			
56	35310024	00087	VI	948	0	6,0	954	0	5,19,2	1,309	0	5,19,2	1,309	0	5,19,0	910			
57	35310026	00017	VI	944	0	7,0	1,113	0	5,19,0	1,291	0	5,19,0	1,311	0	5,19,0	910			
58	35310008	00247	VI	164	0	2,0	318	0	1,2,1	251	0	1,2,1	271	0	1,2,0	182			
59	35310011	00187	I-A-3	57	66	0,1	219	66	1,1,0	173	66	1,1,0	193	66	1,2,0	182			
60	35310026	00097	VI	1,120	0	10,12	5,787	0	11,9,3	2,642	0	11,9,3	2,642	0	15,32,0	2,808			
61	35310026	00147	I-A-3	44	71	1,0	159	71	1,2,0	212	71	1,2,0	232	71	1,2,0	182			
62	35310009	00157	VI	543	0	2,2	756	0	3,11,0	771	0	3,11,0	791	0	3,6,0	544			
TOTALS				10,411	20,085		845,609	28,790		330,571	29,268		334,836	28,543		344,017			

1/ Ventilation configuration code from the methodology given in Appendix 2.
 2/ The two numbers given in this column are, respectively, the number of 1-man 20-inch PVK's and the number of 2-man 20-inch PVK's recommended in the SPIS-PVK Survey.
 3/ These costs represent the equipment costs only.
 4/ Desk Survey indicates the application of the methodology using available SPIS data only.
 5/ The numbers in this column represent, respectively, the number of 10-inch ventilators, the number of 16-inch Kentry pumps, and the number of 72-inch Kentry pumps recommended in this ventilation plan.
 6/ These costs include equipment costs plus \$30 per facility for survey costs.
 7/ Field Survey indicates the application of the methodology using available SPIS data supplemented by a field visit.
 8/ These costs include equipment costs plus \$30 per facility for survey costs.
 9/ Nucleic Area Survey indicates allocation of ventilation equipment solely on the basis of the nucleic area in each facility.
 10/ These costs include equipment costs only. Survey cost for this method is assumed to be zero.

The most significant decrease in cost between the Desk Survey and the Field Survey also occurs in Building Number 10 in which the cost drops from \$1,590 in the Desk Survey to \$1,129 in the Field Survey. This is a total decrease in cost of \$461. Significant decreases in cost also occur in Building Numbers 5, 7, 22, 29, and 47.

The total number of spaces which could be added in the 62 facilities through ventilation improvements, if all usable area in every shelter were fully utilized, is 29,564. The number added in the Field Survey was 29,080, which means that only 484 spaces could not be adequately ventilated. These spaces occurred in dead-end rooms which were ventilated with Kearny pumps and which contained more spaces than the rated capacity of a Kearny pump. These rooms were situated within the shelter such that it was not feasible to place one of the allocated PVK's in them. Therefore, in order to fully utilize the space in these rooms, the only alternative to the use of a Kearny pump was to allocate an additional PVK. This alternative was considered to be uneconomical. The 484 spaces missed for this reason occurred in 29 rooms contained in 17 of the facilities. This was from a total of 151 dead-end rooms in 62 facilities.

Table III summarizes the results of each survey and includes the average cost per space added for the entire sample for each survey. The costs given in this table include equipment and survey costs except for the NFSS-PVK Survey, which indicates equipment costs only. Note in Table III that the cost of \$1.19 per space added for the Field Survey is less than the cost of \$1.34 per space added for the Desk Survey, even though the labor cost for the Field Survey is \$50 per building and the labor cost for the Desk Survey is only \$30 per building. The reason for the lower cost for the Field Survey is that the additional data obtained during the field visit permitted more efficient ventilation plans to be designed. Following are several comparisons between the Desk Survey and the Field Survey which emphasize the increased efficiency of the ventilation systems resulting from the Field Survey.

- 1) The Desk Survey indicated that the exterior openings in 12 of the 62 buildings were inadequate to permit use of the required number of ventilators; the Field Survey revealed that the apertures were sufficient in all cases.

Table III

SUMMARY OF RESULTS FROM 62-BUILDING SURVEYS
(PVK Survey Data Available)

Method	Spaces Added	Total Cost	Cost Per Space Added	Percent Increase in Spaces Added
NFSS-PVK Survey	26,085	\$ 65,609	\$ 2.52	---
New Methodology NFSS Data Only (Desk Survey)	28,780	38,571	1.34	10.4
New Methodology NFSS Data and Field Visit (Field Survey)	29,268	34,856	1.19	11.5
Usable Shelter Area Method (Usable Area Survey)	28,543	\$ 44,017	1.54	8.7

- 2) In the Desk Survey, 4 of the buildings were ventilated using Kearny pumps only; in the Field Survey, 8 of the buildings were ventilated using Kearny pumps only.
- 3) In the Desk Survey, 13 of the buildings were ventilated using zero duct lengths with the PVK's; in the Field Survey, 26 of the buildings were ventilated using zero duct lengths.
- 4) In the Desk Survey, 13 of the buildings required a duct length greater than 150 feet; in the Field Survey, only 1 building required a duct length greater than 150 feet.

The cost of \$1.54 per space added in the Usable Area Survey is higher than either of the other applications of the methodology. This is due to inefficient allocation of ventilation equipment based on only one parameter (floor area) without regard to aperture sizes and configuration.

2. Buildings Without PVK Survey Data Available

Tables IV and V give NFSS data and the results for each of the three allocation methods applied to the 18 buildings which have not been evaluated in the NFSS-PVK Survey. Table IV identifies each building by Standard Location and Facility Number, gives the existing spaces in each building, and shows the equipment allocated, spaces gained, and total cost for each building for each of the three survey methods. It is interesting to note that in both the Desk Survey and the Field Survey, it was possible to ventilate all of the spaces listed in the NFSS as potentially available through ventilation improvements. A total of 183 of the potential spaces could not be adequately ventilated with the equipment allocated in the Usable Area Survey.

Table V shows the results of each survey in summary form and gives the average cost per space added for each of the allocation methods. In this analysis, the increased efficiency of the ventilation plans defined after the field visit did not fully compensate for the added cost of the field visit as was the case for the 62 buildings; therefore, the cost per space added for the Field Survey was slightly higher than the cost per space added for the Desk Survey.

The 18 buildings in this analysis were generally much smaller than the 62 buildings which have been surveyed in the NFSS-PVK Survey. This is evidenced by the fact that 13 of the 18 are in the single room configuration. Additionally, the average number of total spaces (existing plus added) per building for the 18 building sample is 342 and the average number of total

Table IV
 SURVEY RESULTS FOR BUILDINGS WITHOUT PVK SURVEY DATA AVAILABLE
 (18 Buildings)

Building Number	Standard Location	Facility Number	Ventilator ^{1/} Configuration Code	MFSS			Allocation and Deployment Methodology				Total Cost ^{8/}			
				Existing Spaces	Potential Spaces Thru Ventilator Improvements	Added Spaces	Desk Survey ^{2/}	Field Survey ^{3/}	Usable Area Survey ^{7/}	Total Cost ^{6/}		Ventilation Equipment ^{5/}		
1	35310010	00022	VI	172	1,063	1,063	6,141.1	\$1,239	1,063	6,12.0	\$1,142	1,063	6,13.0	\$1,131
2	35310010	00033	I-A-5	24	88	88	1,2.0	212	88	1,0.0	154	88	1,2.0	182
3	35310010	00034	I-A-3	24	88	88	1,0.0	134	88	1,0.0	154	88	1,2.0	182
4	35310010	00035	I-A-5	29	106	106	1,1.0	134	106	1,1.0	154	106	1,2.0	182
5	35310010	00036	I-A-5	14	117	117	1,0.0	134	117	1,0.0	154	117	1,2.0	182
6	35310010	00037	I-A-2	172	690	690	3,5.0	537	690	3,4.0	518	690	4,9.0	767
7	35310010	00041	I-A-2	29	134	134	1,0.0	134	134	1,0.0	154	134	1,2.0	182
8	35310010	00046	I-A-5	35	115	115	1,1.0	173	115	1,0.0	154	115	1,2.0	182
9	35310018	00408	I-A-3	138	224	224	1,2.0	212	224	1,4.0	310	224	2,3.0	325
10	35310010	00051	I-A-5	279	655	655	5,0.0	550	655	5,1.0	609	655	5,9.0	871
11	35310010	00055	I-A-5	10	57	57	1,0.0	134	57	1,1.0	193	57	1,1.0	143
12	35310010	00042	I-A-5	92	293	293	2,0.0	238	293	2,3.0	375	293	2,4.0	364
13	35310010	00047	I-A-5	11	71	71	1,3.0	251	71	1,3.0	271	71	1,1.0	143
14	35310010	00021	IV-3	33	323	323	2,12.0	706	323	2,7.0	531	263	2,4.0	364
15	35310010	00020	VI	117	371	371	2,3.0	355	371	2,6.2	570	281	3,5.0	507
16	35310010	00019	I-A-2	56	179	179	0,1.1	108	179	0,0.1	89	179	2,3.0	325
17	35310010	00004	II-A-5	96	179	179	2,4.0	394	179	2,2.0	336	179	2,3.0	325
18	35310009	00785	I-A-3	21	197	197	0,0.1	69	197	0,1.1	128	197	1,3.0	221
Totals				1,360	4,850	4,850		\$5,714	4,850		\$5,996	4,667		\$6,578

1/ Ventilation configuration code from the methodology given in Appendix B.

2/ Desk survey indicates the application of the methodology using available MFSS data only.

3/ The numbers in this column represent, respectively, the number of 30-inch ventilators, the number of 36-inch Kearney pumps, and the number of 72-inch Kearney pumps recommended for this ventilation plan.

4/ These costs include equipment costs plus \$30 per facility for survey costs.

5/ Field survey indicates the application of the methodology using MFSS data supplemented by a field visit.

6/ These costs include equipment costs plus \$50 per building for survey costs.

7/ Usable area survey indicates allocation of ventilation equipment solely on the basis of the usable area in each facility.

8/ These costs include equipment costs only. Survey cost for this method is assumed to be zero.

Table V

SUMMARY OF RESULTS FROM 18-BUILDING SURVEYS
(PVK Survey Data Not Available)

Method	Spaces Added	Total Cost	Cost Per Space Added
New Methodology NFSS Data Only (Desk Survey)	4,850	\$ 5,714	\$ 1.17
New Methodology NFSS Data and Field Visit (Field Survey)	4,850	5,996	1.23
Usable Shelter Area Method (Usable Area Survey)	4,667	\$ 6,578	\$ 1.41

spaces per building for the 62 building sample is 737. In addition, in 50 percent of the 18 buildings, the required ventilation was supplied in the Field Survey by one PVK ventilator while this was true for only 26 percent of the 62 buildings. These smaller buildings showed fewer changes in the ventilation systems between Desk Survey and the Field Survey.

F. Conclusions

On the basis of the test applications of the methodology, the following conclusions are drawn:

- 1) Ventilation plans can be defined for NFSS structures requiring additional ventilation without visiting the facilities. However, the cost-effectiveness of the methodology application is highest if a visit is made to each building to obtain additional information.
- 2) Usable ventilation plans can also be defined on the basis of the usable shelter area in a facility. This particular method could easily be adapted to computer analysis and would therefore practically eliminate survey costs; however, the overall cost-effectiveness of this method is less than the Desk Survey and Field Survey methods.
- 3) The largest increase in spaces added was noted in the Field Survey, which indicates an 11.5 percent increase over the NFSS-PVK Survey results. The majority of these spaces added were in rooms of less than 500 square feet, which accounted for 63 percent of the rooms requiring ventilation and 11 percent of the shelter spaces. In the statistical sample of buildings selected for the RTI study described in Reference 2, it was estimated that 73 percent of all rooms contained in NFSS shelter stories requiring additional ventilation have an area of less than 500 square feet, and that these rooms contain 22 percent of the total spaces on these stories. This implies that an application of the methodology, as described in the Field Survey approach, to all NFSS buildings requiring additional ventilation would yield an increase of approximately 20 percent in spaces added.

IV. RECOMMENDATIONS

A. Additional Data

If sufficient data were available from Phases 1 and 2 of the National Fallout Shelter Survey, the cost-effectiveness obtained during the Field Survey application of the methodology could be realized using only a Desk Survey. For this reason, it is recommended that in future NFSS surveys the following additional data be obtained during the initial visit to a building for those shelters requiring additional ventilation.

- 1) The location and dimensions of all exterior openings should be shown on the shelter marking sketch for the stories requiring additional ventilation. These would include, in addition to doors and windows, such openings as ventilation shafts, pipe shafts, openings for exhaust fans, coal chutes, sidewalk elevators, and any other openings which could be utilized as a source of fresh air or as a means of exhausting air from the shelter.
- 2) The shelter marking sketches should also indicate the configuration of stairways and elevator shafts. This information should include an indication that a stairway is either open or is enclosed in a stairwell with doors. The accessibility of outside air through a stairway or elevator shaft on the story adjacent to the story to be ventilated should also be indicated.
- 3) Shelter marking sketches for those stories requiring additional ventilation should show all interior partitions and all apertures in the interior partitions. In addition, the total usable shelter area in each room of the shelter should be indicated.

B. Additional Research

The test applications of the methodology were made in only two (2) localized geographic areas and the previous NFSS surveys in these areas were performed by a small number of contractors. The conclusions drawn from this test, therefore, are not necessarily applicable on a national basis. In order to verify the applicability of the methodology, the adequacy of the existing NFSS data, and the usefulness of the methodology in obtaining additional spaces, it is recommended that further applications of the methodology be made on a statistical sample of facilities drawn from the universe of the entire NFSS inventory.

A test application of the methodology on a sample of buildings of this type could yield a variety of information useful in OCD planning. It could provide estimates of the numbers and mixture of ventilation equipment needed to be purchased. It could also provide estimates of potential additional spaces, which would allow CSP planners to reallocate personnel from above-ground shelters to below-grade shelters to improve their protection from both blast and radiation. It would also allow for options in future OCD ventilation survey program planning since the methodology presents applications which may be chosen on a basis other than cost-effectiveness. For example, in some areas it may be more desirable to accept the higher cost of ventilating shelters without visiting the facilities rather than risk a decline in public relations which the visits might invoke.

REFERENCES

1. Office of Civil Defense. Selected Statistics of the Fallout Shelter Program. Washington, D. C.: Office of Civil Defense, Department of Defense, 25 December 1969.
2. E. L. Hill, J. G. Caldwell, and W. K. Grogan. Determination of Shelter Configuration for Ventilation. Final Report R-OU-177. Research Triangle Park, North Carolina: Research Triangle Institute, July 1965.
3. B. A. Libovicz and H. F. Behls. Shelter Package Ventilation Kit. GARD Report 1244. Niles, Illinois: General American Transportation Corporation, October 1965.
4. Department of the Army. National Fallout Shelter Survey Program PVK Survey Instructions. Washington, D. C.: Office of the Chief of Engineers.
 - a. 18 March 1966
 - b. 1 April 1967
 - c. 1 August 1967
 - d. 1 July 1969
5. General American Transportation Corporation. Niles, Illinois. December 1968. Personal Communication.
6. Cresson H. Kearny. Manual Shelter-Ventilating Devices for Crowded Shelters Cooled by Outside Air--A Preliminary Report. Tennessee: Oak Ridge National Laboratory, 8 June 1965.
7. O. W. Svaeri and N. I. Stein. Air Distribution Studies in Multi-Room Shelters. Final Report. Washington, D. C.: Office of the Chief of Engineers, Department of the Army, March 1967.

APPENDIX A
Description of NFSS Data

Appendix A

Description of NFSS Data

I. INTRODUCTION

This appendix describes the existing NFSS data which can be used in the development of ventilation plans for buildings. Data sources include NFSS Phase 1, NFSS Phase 2, and the PVK Survey. These data describe structural parameters of buildings used in shielding analyses, results of the shielding analyses, and information such as room sizes and shelter layout relevant to ventilation improvements. For shelters with relatively simple configurations and when the survey forms are prepared in complete accordance with instructions, these data are usually sufficient to permit a ventilation plan to be defined using the new methodology. For more complex configurations, these data alone may not be sufficient; however, as pointed out below, many of the data sources contain items of valuable data not required by the instructions.

II. NFSS PHASE 1 DATA

A. FOSDIC (Film Optical Sensing Device for Input to Computers)

Prior to February 1967, the FOSDIC Form was used in Phase 1 of the NFSS to report data for input to a computer program which calculated protection factors of buildings. Figure A-1 is an example of a completed FOSDIC Form. Items of data contained on this form which are relevant to this study are contained in Section 23, Structural Details. These items include basement ceiling height above grade and apertures in exterior walls. The instructions for filling out the FOSDIC Form [Ref. A-1] require that the basement ceiling height above grade be reported to the nearest foot for each side, and that the area of the exposed portion of each exterior wall occupied by apertures be recorded to the nearest 10 percent. A master file containing the FOSDIC input data for all buildings surveyed using this form is maintained on magnetic tape at the National Civil Defense Computer Facility (NCDCF).

B. SAF (Shielding Analysis Form)

Since February 1967, the SAF (Figure A-2) has been used in Phase 1 of the NFSS to report data as the input for computer computation of protection factors in buildings. Data contained on the SAF which are useful in defining building

ventilation characteristics appear in Section E, Apertures. The Phase 1 survey instructions [Ref. A-2] require that the total width of windows and doors, the predominant or average vertical distance from the floor to sills, and the average vertical distance from the floor to the top of the apertures be reported to the nearest foot for each building side. Data reported on these forms are also maintained on magnetic tape in the master file at NCDCF.

III. NFSS PHASE 2 DATA

Two forms used in Phase 2 of the NFSS contain data useful in defining ventilation plans for buildings. These are the Phase 2 Data Collection Form (DCF) and the shelter marking sketch. Since March 1965, the Phase 2 Survey instructions [Ref. A-3] require that the shelter marking sketches show the shelter areas and shelter access. Prior to that time, the instructions required only that the shelter area be identified on the sketch. The shelter marking sketch (Figure A-3) shows the location of spaces in PF Categories 2-8 on an outline sketch of the shelter story. Even though not required, many of these sketches show the locations of interior partitions, and some include exterior and interior apertures. Stairways and elevators are shown on most of the sketches prepared since 1965.

The items of data on the Phase 2 DCF (Figure A-4) which are pertinent to this study are in Section B, Data Summary. These items appear in the columns with the headings "Existing Shelter" and "Ventilation Improvement." Prior to 1965, these items were determined according to the instructions given in Ref. A-4. Since 1965, the spaces entered under "Ventilation Improvements" are as determined in the PVK Survey [Ref. A-5]. Prior to February 1967, the sill height information was given on this form to supplement the aperture data reported on the FOSDIC Form. The Phase 2 DCF data are maintained on magnetic tape in the master file at NCDCF.

IV. PVK SURVEY DATA

The Packaged Ventilation Kit (PVK) Survey determined the number of spaces that could be added in a facility by ventilation improvements and identified the equipment needed to supply the additional ventilation. The criterion for selecting buildings for the PVK survey was that it must contain at least one room with a capacity of at least 50 spaces after the ventilation improvements [Ref. A-5]. The PVK Survey Form (Figure A-5) gives the existing and potential spaces as well as the duct lengths required for each room in the facility. The PVK Survey Form also contains a sketch which shows the partition configuration for the story or stories requiring ventilation improvements. Although the survey instructions only require that partitions be shown, some sketches show exterior and/or interior aperture locations and/or stair and elevator locations.

V. REFERENCES

- A-1 Department of the Army. Instructions for Filling Out DD Form 1356 (1 Nov. 1961): National Fallout Shelter Survey - Phase 1. Washington, D. C.: Office of the Chief of Engineers, December 1961.
- A-2 Department of the Army. National Fallout Shelter Survey Program - Phase 1 Survey Instructions. Washington, D. C.: Office of the Chief of Engineers, December 1966.
- A-3 Department of the Army. Fallout Shelter Survey Updating Instructions. Washington, D. C.: Office of the Chief of Engineers, March 1965.
- A-4 Department of the Army. Fallout Shelter Survey Instructions - Phase 2. Washington, D. C.: Office of the Chief of Engineers, March 1962.
- A-5 Department of the Army. National Fallout Shelter Survey Program PVK Survey Instructions. Washington, D. C.: Office of the Chief of Engineers, April 1967.

NATIONAL FALLOUT SHELTER SURVEY
Phase 1

01

014A LADY OF GRACE CATH. CHURCH 2201 W MARKET CIRCLE MC315410007

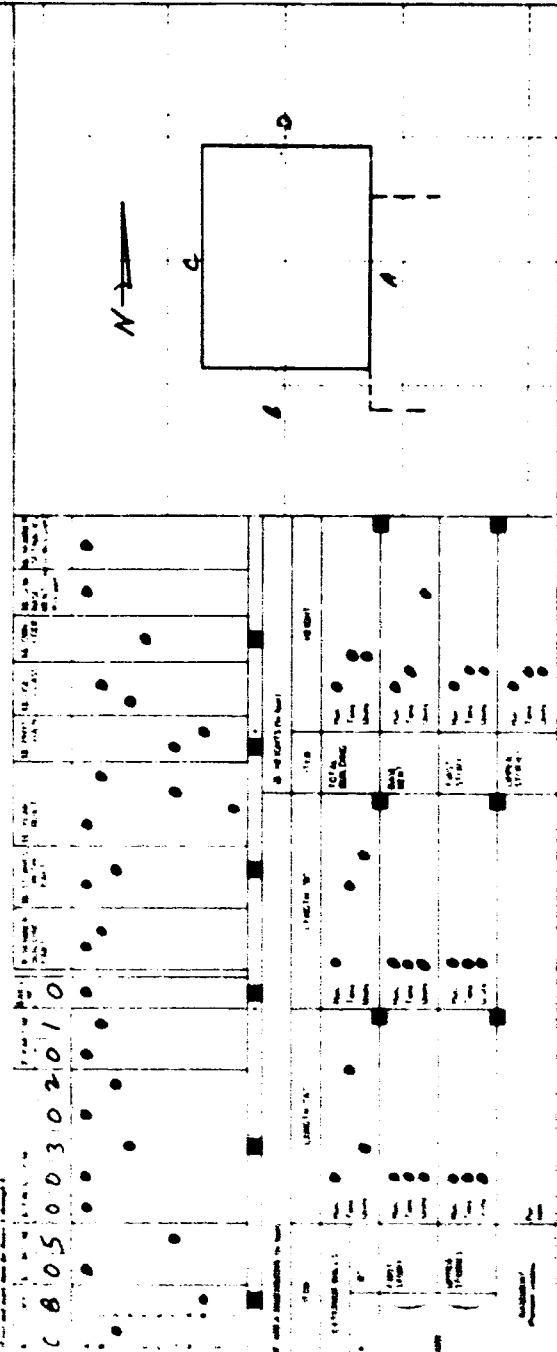

Point	Distance to Edge of Room (ft)	Distance to Edge of Room (ft)	Distance to Edge of Room (ft)	Distance to Edge of Room (ft)
1	10	10	10	10
2	10	10	10	10
3	10	10	10	10
4	10	10	10	10
5	10	10	10	10
6	10	10	10	10
7	10	10	10	10
8	10	10	10	10
9	10	10	10	10
10	10	10	10	10
11	10	10	10	10
12	10	10	10	10
13	10	10	10	10
14	10	10	10	10
15	10	10	10	10
16	10	10	10	10
17	10	10	10	10
18	10	10	10	10
19	10	10	10	10
20	10	10	10	10
21	10	10	10	10
22	10	10	10	10
23	10	10	10	10
24	10	10	10	10
25	10	10	10	10
26	10	10	10	10
27	10	10	10	10
28	10	10	10	10
29	10	10	10	10
30	10	10	10	10
31	10	10	10	10
32	10	10	10	10
33	10	10	10	10
34	10	10	10	10
35	10	10	10	10
36	10	10	10	10
37	10	10	10	10
38	10	10	10	10
39	10	10	10	10
40	10	10	10	10
41	10	10	10	10
42	10	10	10	10
43	10	10	10	10
44	10	10	10	10
45	10	10	10	10
46	10	10	10	10
47	10	10	10	10
48	10	10	10	10
49	10	10	10	10
50	10	10	10	10

Point	Distance to Edge of Room (ft)	Distance to Edge of Room (ft)	Distance to Edge of Room (ft)	Distance to Edge of Room (ft)
51	10	10	10	10
52	10	10	10	10
53	10	10	10	10
54	10	10	10	10
55	10	10	10	10
56	10	10	10	10
57	10	10	10	10
58	10	10	10	10
59	10	10	10	10
60	10	10	10	10
61	10	10	10	10
62	10	10	10	10
63	10	10	10	10
64	10	10	10	10
65	10	10	10	10
66	10	10	10	10
67	10	10	10	10
68	10	10	10	10
69	10	10	10	10
70	10	10	10	10
71	10	10	10	10
72	10	10	10	10
73	10	10	10	10
74	10	10	10	10
75	10	10	10	10
76	10	10	10	10
77	10	10	10	10
78	10	10	10	10
79	10	10	10	10
80	10	10	10	10
81	10	10	10	10
82	10	10	10	10
83	10	10	10	10
84	10	10	10	10
85	10	10	10	10
86	10	10	10	10
87	10	10	10	10
88	10	10	10	10
89	10	10	10	10
90	10	10	10	10
91	10	10	10	10
92	10	10	10	10
93	10	10	10	10
94	10	10	10	10
95	10	10	10	10
96	10	10	10	10
97	10	10	10	10
98	10	10	10	10
99	10	10	10	10
100	10	10	10	10

Fig. A-1. Example FOSDIC Form. (Continued)

<p><i>G. M. Brown</i></p> <p>9/9/62</p>		<p>BASEMENT FLOOR</p>		<p>FIRST FLOOR</p>		<p>UPPER FLOOR</p>		<p>ROOF</p>	
<p>1. MARK OF THE CASE</p>	<p>2. NUMBER OF THE CASE</p>	<p>3. NUMBER OF THE CASE</p>	<p>4. NUMBER OF THE CASE</p>	<p>5. NUMBER OF THE CASE</p>	<p>6. NUMBER OF THE CASE</p>	<p>7. NUMBER OF THE CASE</p>	<p>8. NUMBER OF THE CASE</p>	<p>9. NUMBER OF THE CASE</p>	<p>10. NUMBER OF THE CASE</p>
<p>11. MARK OF THE CASE</p>	<p>12. NUMBER OF THE CASE</p>	<p>13. NUMBER OF THE CASE</p>	<p>14. NUMBER OF THE CASE</p>	<p>15. NUMBER OF THE CASE</p>	<p>16. NUMBER OF THE CASE</p>	<p>17. NUMBER OF THE CASE</p>	<p>18. NUMBER OF THE CASE</p>	<p>19. NUMBER OF THE CASE</p>	<p>20. NUMBER OF THE CASE</p>
<p>21. MARK OF THE CASE</p>	<p>22. NUMBER OF THE CASE</p>	<p>23. NUMBER OF THE CASE</p>	<p>24. NUMBER OF THE CASE</p>	<p>25. NUMBER OF THE CASE</p>	<p>26. NUMBER OF THE CASE</p>	<p>27. NUMBER OF THE CASE</p>	<p>28. NUMBER OF THE CASE</p>	<p>29. NUMBER OF THE CASE</p>	<p>30. NUMBER OF THE CASE</p>
<p>31. MARK OF THE CASE</p>	<p>32. NUMBER OF THE CASE</p>	<p>33. NUMBER OF THE CASE</p>	<p>34. NUMBER OF THE CASE</p>	<p>35. NUMBER OF THE CASE</p>	<p>36. NUMBER OF THE CASE</p>	<p>37. NUMBER OF THE CASE</p>	<p>38. NUMBER OF THE CASE</p>	<p>39. NUMBER OF THE CASE</p>	<p>40. NUMBER OF THE CASE</p>
<p>41. MARK OF THE CASE</p>	<p>42. NUMBER OF THE CASE</p>	<p>43. NUMBER OF THE CASE</p>	<p>44. NUMBER OF THE CASE</p>	<p>45. NUMBER OF THE CASE</p>	<p>46. NUMBER OF THE CASE</p>	<p>47. NUMBER OF THE CASE</p>	<p>48. NUMBER OF THE CASE</p>	<p>49. NUMBER OF THE CASE</p>	<p>50. NUMBER OF THE CASE</p>
<p>51. MARK OF THE CASE</p>	<p>52. NUMBER OF THE CASE</p>	<p>53. NUMBER OF THE CASE</p>	<p>54. NUMBER OF THE CASE</p>	<p>55. NUMBER OF THE CASE</p>	<p>56. NUMBER OF THE CASE</p>	<p>57. NUMBER OF THE CASE</p>	<p>58. NUMBER OF THE CASE</p>	<p>59. NUMBER OF THE CASE</p>	<p>60. NUMBER OF THE CASE</p>
<p>61. MARK OF THE CASE</p>	<p>62. NUMBER OF THE CASE</p>	<p>63. NUMBER OF THE CASE</p>	<p>64. NUMBER OF THE CASE</p>	<p>65. NUMBER OF THE CASE</p>	<p>66. NUMBER OF THE CASE</p>	<p>67. NUMBER OF THE CASE</p>	<p>68. NUMBER OF THE CASE</p>	<p>69. NUMBER OF THE CASE</p>	<p>70. NUMBER OF THE CASE</p>
<p>71. MARK OF THE CASE</p>	<p>72. NUMBER OF THE CASE</p>	<p>73. NUMBER OF THE CASE</p>	<p>74. NUMBER OF THE CASE</p>	<p>75. NUMBER OF THE CASE</p>	<p>76. NUMBER OF THE CASE</p>	<p>77. NUMBER OF THE CASE</p>	<p>78. NUMBER OF THE CASE</p>	<p>79. NUMBER OF THE CASE</p>	<p>80. NUMBER OF THE CASE</p>
<p>81. MARK OF THE CASE</p>	<p>82. NUMBER OF THE CASE</p>	<p>83. NUMBER OF THE CASE</p>	<p>84. NUMBER OF THE CASE</p>	<p>85. NUMBER OF THE CASE</p>	<p>86. NUMBER OF THE CASE</p>	<p>87. NUMBER OF THE CASE</p>	<p>88. NUMBER OF THE CASE</p>	<p>89. NUMBER OF THE CASE</p>	<p>90. NUMBER OF THE CASE</p>
<p>91. MARK OF THE CASE</p>	<p>92. NUMBER OF THE CASE</p>	<p>93. NUMBER OF THE CASE</p>	<p>94. NUMBER OF THE CASE</p>	<p>95. NUMBER OF THE CASE</p>	<p>96. NUMBER OF THE CASE</p>	<p>97. NUMBER OF THE CASE</p>	<p>98. NUMBER OF THE CASE</p>	<p>99. NUMBER OF THE CASE</p>	<p>100. NUMBER OF THE CASE</p>

Fig. A-1 (Continued). Example FOSDIC Form.

DEPARTMENT OF DEFENSE
OFFICE OF THE SECRETARY OF THE ARMY
OFFICE OF CIVIL DEFENSE

NATIONAL FALLOUT SHELTER SURVEY
Shielding Analysis Form

1. Page No. 01

CONTINUED

FIBERS RTP NC 27709

CONTAMINATED PLACES (Dimensions in feet)

		Side A	Side B	Side C	Side D
a. Sector degrees	0	0	0	0	0
b. Midline wall dist.	1	1	1	1	1
Plane 1	1	0	0	0	0
Plane 2	2	0	0	0	0
Plane 3	3	0	0	0	0

Asymmetrical Sector 1

		One sector only	One sector only	One sector only	Two sectors only
a. Sector degrees	1	0	5	5	0
b. Midline wall dist.	2	0	8	5	0
Plane 1	1	0	0	1	0
Plane 2	2	0	1	5	0
Plane 3	3	0	1	2	5

Asymmetrical Sector 2

		Two sectors only	Two sectors only	Two sectors only	Two sectors only
a. Sector degrees	3	0	7	2	0
b. Midline wall dist.	4	0	7	5	0
Plane 1	1	0	0	1	0
Plane 2	2	0	3	0	0
Plane 3	3	0	0	0	0

Asymmetrical Sector 3

		Sum of Ap. width	Floor to head hgt.	Sum of Ap. width	Floor to head hgt.	Sum of Ap. width	Floor to head hgt.	Sum of Ap. width	Floor to head hgt.
1. Atrium	11	0	0	0	1	2	0	0	0
2. Basement	12	0	0	0	0	0	0	0	0
3. First story	13	0	4	8	0	7	0	0	0
4. Upper stories	14	0	4	8	0	0	0	0	0
5. Upper stories (if changed)	15	0	0	0	0	0	0	0	0
6. Story number of change	16								

APERTURES (Dimensions in ft.)

BUILDING SKETCH

SMALL STRUCTURE DATA ONLY

1. Name	2. Base	3. Upper stories	4. Director	5. Director	6. Director	7. Director	8. Director	9. Director	10. Director
06300	151815	0	0	320	1600	1	0	0	0

DIMENSIONAL DATA

1. Total height	2. Base height	3. Upper stories	4. Director	5. Director	6. Director	7. Director	8. Director	9. Director	10. Director
15867	400	1966	00	1200	40	0	0	0	0

IDENTIFICATION

1. Name: FIBERS RTP NC 27709

2. Base: 06300

3. Upper stories: 151815

4. Director: 0

5. Director: 320

6. Director: 1600

7. Director: 1

8. Director: 0

9. Director: 0

10. Director: 0

Fig. A-2. Example SAF Form.

(Continued)

F. EXTERIOR WALLS MASS THICKNESS (psf in units)	No. data req'd	Story No.	Side A	Side B	Side C	Side D	Partition 1		Partition 2		Partition 3		Partition 4	
							Distance	psf	Distance	psf	Distance	psf	Distance	psf
1. Aisway	12		0	150	0	0	0	3255	0	0	0	0	0	0
2. Basement or crawl space			150	150	150	150	0	0	0	0	0	0	0	0
3. First story			075	075	075	075	0	55	22	45	0	0	0	0
4. Upper stories			075	075	075	075	0	55	22	45	0	0	0	0
5. Upper stories (if change)	15		062	062	062	062	0	0	0	0	0	0	0	0
6. Story number of change			03	03	03	03	0	0	0	0	0	0	0	0
G. SETBACK AND OVERHANG LOCATION (Width of offset in feet)			S=Setback O=Overhang	S=Setback O=Overhang	S=Setback O=Overhang	S=Setback O=Overhang								
1. Offset No. 1	16		035	064	51	92								
2. Offset No. 2														
3. Offset No. 3														
H. BASEMENT EXTENSION														
1. Distance out from side (ft.)	17													
2. Overhead mass thickness (psf in units)														
J. PARTIAL BASEMENT LOCATION (Distance from side in feet)														
Basement No. 1 Dist. to nearest side	18													
Basement No. 2 Dist. to nearest side														
Basement No. 4 Dist. to far side														
K. SPECIAL DETECTOR LOCATION (Distance from side in feet)														
1. Basement														
2. First story														
3. Upper stories														
4. Upper stories (if change)	19													
5. Upper stories (if change)														
6. Upper stories (if change)														
L. ROOF AND OFFSET MASS THICKNESS (psf in units)	20													
1. Main Roof			028	028	028	028								
2. Upper Floors (if change)			075	062	075	075								
3. Basement Floor														
4. Areaway 1														
5. Areaway 2														
6. Areaway 3														
7. Areaway 4														
M. FLOOR MASS THICKNESS (psf in units)														
1. Side/story	21													
2. Hgt. area flr. above story flr.														
3. Width														
4. Length														
5. Distance to corner of bldg.														

Analyst (Signature) *C.T. Sawyers* Date *10/26/67*
 Checked by (Signature) *N.A. Harrell* Date *10/26/67*

PARTIAL BASEMENT SKETCH

Fig. A-2 (Continued). Example SAF Form.

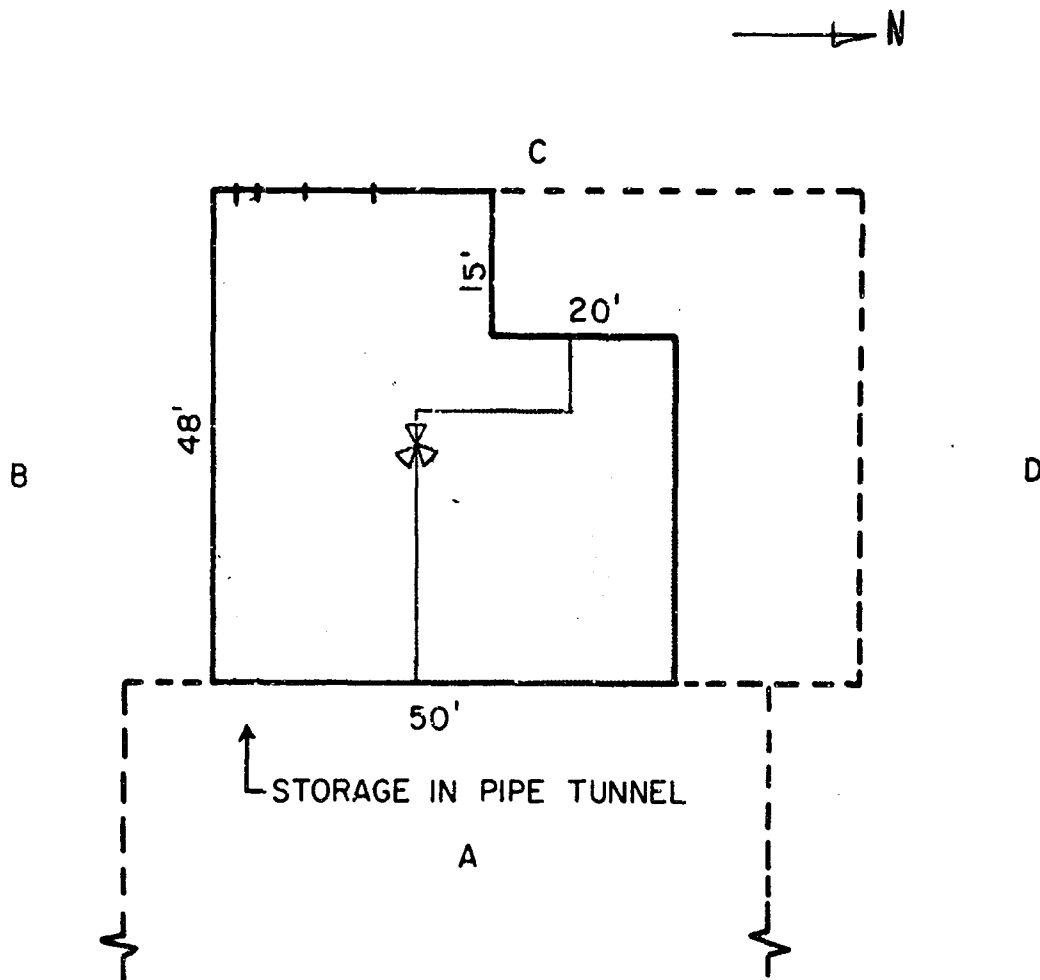

CAP=61

Shelter Limits - Walls _____
 Facility Limits and Interior Shelter
 Limits - - - - -
 Marking Stickers ✂

NAME AND ADDRESS OF FACILITY OUR LADY OF GRACE CATH. CHURCH 2201 W. MARKET ST. GREENSBORO, N. C.			NAME AND ADDRESS OF OWNER BISHOP VINCENT S. WATERS 15 N. MCDOWELL ST. RALEIGH, N. C.		
	Phase 1	Phase 2	Date 5-8-62	Facility # 00302	
Book #	36	05		Part # 01	Story # 00
Page #	02	01	Standard Location: 5041-0007		

Fig. A-3. Example Shelter Marking Sketch.

SECTION A

3. NAME AND ADDRESS OF BUILDING OR SPECIAL FACILITY. Abbreviate to fit in 10 spaces. (Please print)
 GUR LADY OF GRACE CATH CHURCH 2201 W MAR

4. BUILDING NO. 5. FACILITY NO. 6. UNIT NO. 7. NAME OF TUNNEL (If type is subterranean)
 1-2 3 4 5 6 7 8 9 10 11 12
 C180500302010

8. SPECIAL FACILITIES. Enter appropriate code numbers for use facility only.

9. SPECIAL FACILITIES. Enter appropriate code numbers for use facility only.

10. SPECIAL FACILITIES. Enter appropriate code numbers for use facility only.

11. IDENTIFY "OTHER" IF MARKED IN ITEMS 8, 9, OR 10.

12. RODENTS AND DESTRUCTIVE INSECTS.

13. RODENTS AND DESTRUCTIVE INSECTS.

14. REMARKS.

15. SIGNATURE OF CERTIFIED A-1 REPRESENTATIVE AND DATE
 S. M. Brown 10/15/62

16. "OTHER" STORAGE USE

17. "OTHER" STORAGE USE

18. "OTHER" STORAGE USE

19. "OTHER" STORAGE USE

20. "OTHER" STORAGE USE

21. "OTHER" STORAGE USE

22. "OTHER" STORAGE USE

23. "OTHER" STORAGE USE

24. "OTHER" STORAGE USE

25. "OTHER" STORAGE USE

26. "OTHER" STORAGE USE

27. "OTHER" STORAGE USE

28. "OTHER" STORAGE USE

29. "OTHER" STORAGE USE

30. "OTHER" STORAGE USE

31. "OTHER" STORAGE USE

32. "OTHER" STORAGE USE

33. "OTHER" STORAGE USE

34. "OTHER" STORAGE USE

35. "OTHER" STORAGE USE

36. "OTHER" STORAGE USE

37. "OTHER" STORAGE USE

38. "OTHER" STORAGE USE

39. "OTHER" STORAGE USE

40. "OTHER" STORAGE USE

41. "OTHER" STORAGE USE

42. "OTHER" STORAGE USE

43. "OTHER" STORAGE USE

44. "OTHER" STORAGE USE

45. "OTHER" STORAGE USE

46. "OTHER" STORAGE USE

47. "OTHER" STORAGE USE

48. "OTHER" STORAGE USE

49. "OTHER" STORAGE USE

50. "OTHER" STORAGE USE

51. "OTHER" STORAGE USE

52. "OTHER" STORAGE USE

53. "OTHER" STORAGE USE

54. "OTHER" STORAGE USE

55. "OTHER" STORAGE USE

56. "OTHER" STORAGE USE

57. "OTHER" STORAGE USE

58. "OTHER" STORAGE USE

59. "OTHER" STORAGE USE

60. "OTHER" STORAGE USE

61. "OTHER" STORAGE USE

62. "OTHER" STORAGE USE

63. "OTHER" STORAGE USE

64. "OTHER" STORAGE USE

65. "OTHER" STORAGE USE

66. "OTHER" STORAGE USE

67. "OTHER" STORAGE USE

68. "OTHER" STORAGE USE

69. "OTHER" STORAGE USE

70. "OTHER" STORAGE USE

71. "OTHER" STORAGE USE

72. "OTHER" STORAGE USE

73. "OTHER" STORAGE USE

74. "OTHER" STORAGE USE

75. "OTHER" STORAGE USE

76. "OTHER" STORAGE USE

77. "OTHER" STORAGE USE

78. "OTHER" STORAGE USE

79. "OTHER" STORAGE USE

80. "OTHER" STORAGE USE

81. "OTHER" STORAGE USE

82. "OTHER" STORAGE USE

83. "OTHER" STORAGE USE

84. "OTHER" STORAGE USE

85. "OTHER" STORAGE USE

86. "OTHER" STORAGE USE

87. "OTHER" STORAGE USE

88. "OTHER" STORAGE USE

89. "OTHER" STORAGE USE

90. "OTHER" STORAGE USE

91. "OTHER" STORAGE USE

92. "OTHER" STORAGE USE

93. "OTHER" STORAGE USE

94. "OTHER" STORAGE USE

95. "OTHER" STORAGE USE

96. "OTHER" STORAGE USE

97. "OTHER" STORAGE USE

98. "OTHER" STORAGE USE

99. "OTHER" STORAGE USE

100. "OTHER" STORAGE USE

SECTION B DATA SUMMARY (Use additional forms following consecutively in this book or in the next book, if necessary, and cross reference in Item 10.)

ITEM NO.	EXISTING SHELTER OR TUNNEL AREA	SHIELDING IMPROVEMENT		VENTILATION IMPROVEMENT		AUXILIARY POWER		SHELTER DIMENSIONS		INTERIOR PART. M. AVER. MASS. (PSF)		BASEMENT BREAKAWAYS				
		SPACES	SPACES	ADDED VENT. SPACES	CURT. SPACE	TENSILE LOAD PER SPACE (IN KW)	FROM SIDE A (SQ. FT.)	FROM SIDE B (SQ. FT.)	SIDE A (10 FT.)	SIDE B (10 FT.)	SIDE C (10 FT.)	SIDE D (10 FT.)	COM. DIST. (10 FT.)	MT. (10 FT.)	MT. (10 FT.)	
1	0060106100V	0	0	0	0	0	0	0	0	0	0	0	0	0	0	0
2																
3																
4																
5																
6																
7																
8																
9																
10																
11																
12																
13																
14																
15																
16																
17																
18																
19																
20																
21																
22																
23																
24																
25																
26																
27																
28																
29																
30																
31																
32																
33																
34																
35																
36																
37																
38																
39																
40																
41																
42																
43																
44																
45																
46																
47																
48																
49																
50																
51																
52																
53																
54																
55																
56																
57																
58																
59																
60																
61																
62																
63																
64																
65																
66																
67																
68																
69																
70																
71																
72																
73																
74																
75																
76																
77																
78																
79																
80																
81																
82																
83																
84																
85																
86																
87																
88																
89																
90																
91																
92																
93																
94																
95																
96																
97																
98																
99																
100																

Fig. A-4. Example Phase 2 DCF. (Continued)

SECTION D - REMARKS

PREPARED BY: C. E. GRAUELY

DATE: AUG 67

CHECKED BY: W. A. SIMKINS

DATE: 18 OCT 67

SECTION C - DESCRIPTION

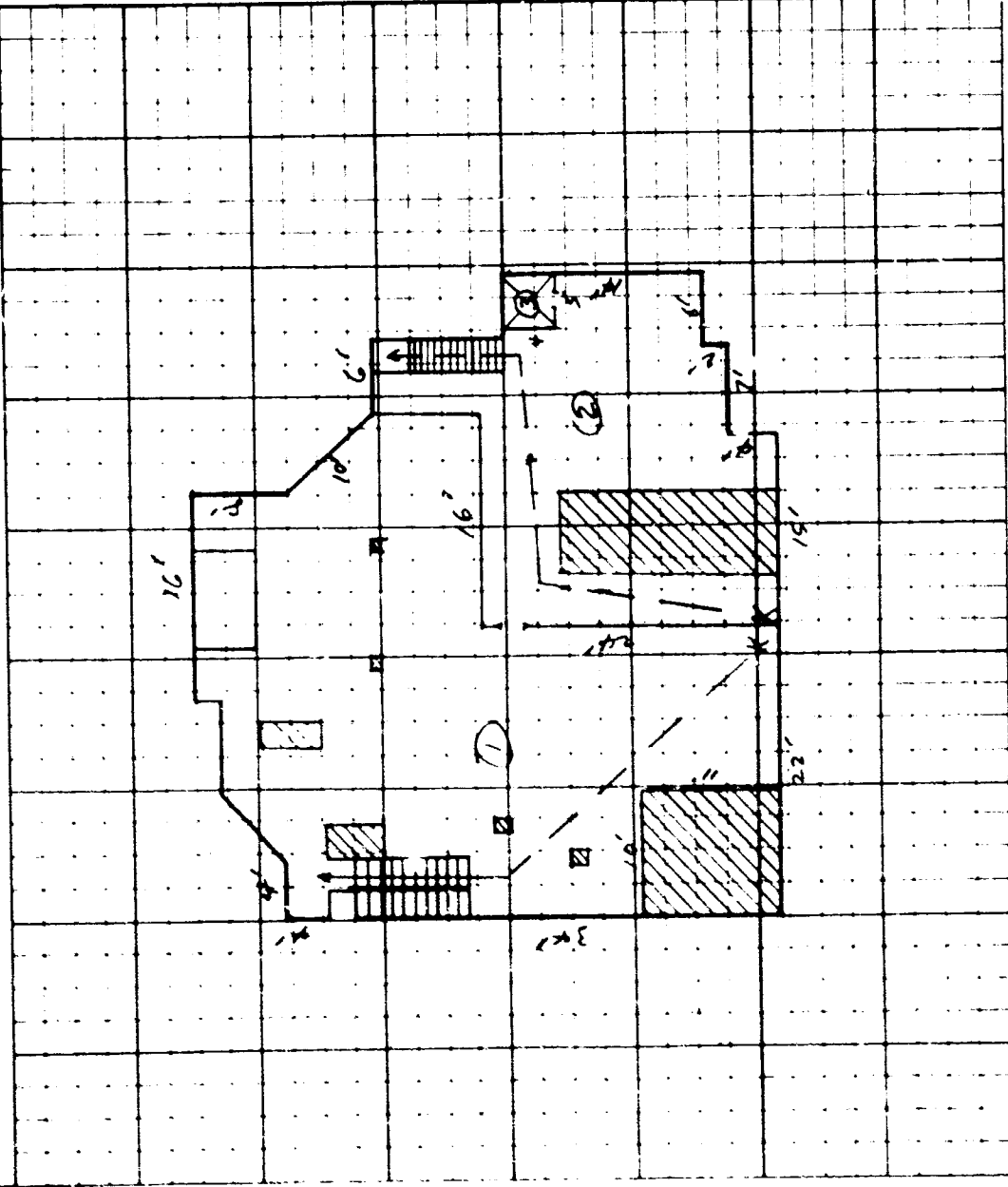

Fig. A-5 (Continued). Example FVK Survey Form.

APPENDIX B
Ventilation Kit Allocation
and Deployment Methodology

Appendix B

Ventilation Kit Allocation and Deployment Methodology

I. INTRODUCTION

The Packaged Ventilation Kit (PVK) Survey Instructions, ER 1190-1-2 [Ref. B-1], describe a procedure to be followed in defining an emergency ventilation system for fallout shelters.

Contained herein is additional information to supplement and modify that given in ER 1190-1-2, including instructions for the use of: (1) a 30-inch PVK ventilator instead of the 20-inch PVK specified in Reference B-1 and (2) a device called a Kearny pump [Ref. B-2] which may be used in conjunction with, or in lieu of, the PVK. Guidance for the deployment of the ventilation equipment within the shelter is also given, with emphasis on placement of ventilators to minimize duct lengths. The sequence of operations followed in defining a ventilation system is as follows:

<u>Step</u>	<u>Description</u>	<u>Reference</u>
1	Determine total usable floor area.	Section II. and App. I of Ref. B-1
2	Determine total air flow requirement.	Section II. and App. V of Ref. B-1
3	Determine equipment options.	Section III.
4	Determine adequacy of apertures.	Section IV.
5	Make adjustments to air flow and, if necessary, repeat Step 3.	Section IV.
6	Choose shelter and aperture configuration.	Section V. B.
7	Determine equipment deployment.	Section V. C.
8	Determine Kearny pumps needed as air mixers.	Section IV.
9	Determine Kearny pumps needed to ventilate rooms with no exterior wall apertures.	Section IV.
10	Fill in data collection form.	Section V.

II. DETERMINATION OF VENTILATION REQUIREMENTS

To determine the ventilation equipment needs for a shelter, the procedures given in Reference B-1 are followed to find the usable shelter area and the required ventilation. Exceptions to Reference B-1 procedures are that rooms of less than 500 square feet in the shelter area are considered as ventilatable, and the required ventilation (air flow) is determined for the entire shelter rather than calculating each room separately.

III. SELECTION OF EQUIPMENT

When the total air flow needed for a shelter has been determined, Table B-I is utilized to determine the types of equipment which may be used to deliver the required quantity of air. Types of equipment considered are the 30-inch packaged ventilation kit (PVK) and the Types I (half-door) and II (full-door) Kearny pumps.

Once the equipment options which will deliver the required quantity of air have been determined, the next step is to select the best combination of equipment for the particular shelter under analysis. The most cost-effective choice is to use a combination of Kearny pumps; however, it may not always be possible to use these due to limitations in aperture dimensions. The next step, therefore, is to examine the apertures to determine which type of ventilators can be used. If it is possible to use Kearny pumps to ventilate a shelter, but the aperture configuration is such that it is not possible to use the number of Kearny pumps of either type specified in Table B-1, Table B-II may be used to determine combinations of Type I and Type II Kearny pumps which will deliver given quantities of air.

If it is determined that Kearny pumps cannot be used to supply air to a shelter, the equivalent duct length needed with PVK's is determined as outlined in Reference B-1 and the required air flow is adjusted before entering Table B-I. The adjusted air flow is found as follows:

For an equivalent duct length (edl) of 100 feet or less (as defined in Reference B-1), divide the required air flow by $(1-0.02edl)$; for equivalent duct lengths greater than 100 feet, divide the required air flow by $(0.9-0.01edl)$.

Table B-I

EQUIPMENT OPTIONS FOR GIVEN AIR FLOW REQUIREMENTS*

CFM	Type I** Kearny Pump	Type II*** Kearny Pump	30-inch Fan
1,600	1	1	1
3,200	2	1	1
3,700	3	1	1
4,100	3	2	1
4,800	3	2	2
6,400	4	2	2
7,400	5	2	2
8,000	5	3	2
8,200	6	3	2
9,600	6	3	3
11,100	7	3	3
11,200	7	4	3
12,300	8	4	3
12,800	8	4	4
14,400	9	4	4
14,800	10	4	4
16,000	10	5	4
16,400	11	5	4
17,600	11	5	5
18,500	12	5	5
19,200	12	6	5
20,500	13	6	5
20,800	13	6	6
22,200	14	6	6
22,400	14	7	6
24,000	15	7	6
24,600	16	7	6
25,600	16	7	7
25,900	17	7	7
27,200	17	8	7

* Data generated assuming maximum air delivery capacity of equipment and no friction losses.

** A type I Kearny pump is the half-door size.

*** A type II Kearny pump is the full-door size.

Table B-1 (Cont'd.)

EQUIPMENT OPTIONS FOR GIVEN AIR FLOW REQUIREMENTS

CFM	Type I Kearny Pump	Type II Kearny Pump	30-inch Fan
28,700	18	8	7
28,800	18	8	8
29,600	19	8	8
30,400	19	9	8
32,000	20	9	8
32,800	21	9	8
33,300	21	9	9
33,600	21	10	9
35,200	22	10	9
36,800	23	10	9
36,900	24	10	9
37,000	24	10	10

Table B-II

COMBINATIONS OF TYPE I AND TYPE II KEARNY PUMPS FOR GIVEN AIR FLOW REQUIREMENTS (CFM)

Number of Type I Kearny Pumps	Number of Type II Kearny Pumps										
	0	1	2	3	4	5	6	7	8	9	10
0	3,700	7,400	11,100	14,800	18,500	22,200	25,900	29,600	33,300	37,000	
1	1,600	5,300	9,000	12,700	16,400	20,100	23,800	27,500	31,200	34,900	38,600
2	3,200	6,900	10,600	14,300	18,000	21,700	25,400	29,100	32,800	36,500	40,200
3	4,800	8,900	12,200	15,900	19,600	23,300	27,000	30,700	34,400	38,100	
4	6,400	10,100	13,800	17,500	21,200	24,900	28,600	32,300	36,000	39,700	
5	8,000	11,700	15,400	19,100	22,800	26,500	30,200	33,900	37,600		
6	9,600	13,300	17,000	20,700	24,400	28,100	31,800	35,500	39,200		
7	11,200	14,900	18,600	22,300	26,000	29,700	33,400	37,100			
8	12,800	16,500	20,200	23,900	27,600	31,300	35,000	38,700			
9	14,400	18,100	21,800	25,500	29,200	32,900	36,600				
10	16,000	19,700	23,400	27,100	30,800	34,500	38,200				
11	17,600	21,300	25,000	28,700	32,400	36,100	39,800				
12	19,200	22,900	26,600	30,300	34,000	37,700					
13	20,800	24,500	28,200	31,900	35,600	39,300					
14	22,400	26,100	29,800	33,500	37,200	40,900					
15	24,000	27,700	31,400	35,100	38,800						
16	25,600	29,300	33,000	36,700	40,400						
17	27,200	30,900	34,600	38,300	42,000						
18	28,800	32,500	36,200	39,900							
19	30,400	34,100	37,800	41,500							
20	32,000	35,700	39,400	43,100							
21	33,600	37,300	41,000								
22	35,200	38,900	42,600								
23	36,800	40,500									
24	38,400	42,100									

IV. ADDITIONAL CRITERIA FOR DEFINING VENTILATION SYSTEMS

In addition to procedures outlined in Sections II and III, the following criteria should be considered when the ventilation system for a fallout shelter is being determined.

- 1) When the air flow through a room is such that it does not cover the entire area of the room, Kearny pumps should be utilized to distribute the air over the total room area. A single 3-foot Kearny pump (Type I) is capable of properly distributing (mixing) air over an area of approximately one thousand (1000) square feet [Ref. B-3].
- 2) A room which has no exterior wall apertures, but which is adjacent to a ventilated room and is connected to the ventilated room by a single doorway may be ventilated by placing a 3-foot Kearny pump in the top half of the doorway. The maximum air flow delivered to the windowless room by this procedure is 460 CFM. If the windowless room is connected to the ventilated room by two or more doorways, it may be ventilated by a 6-foot Kearny pump placed in one of the doorways. The maximum air flow provided to the windowless area in this case is 3700 CFM.
- 3) When a PVK ventilator is used in a shelter, an aperture area equal to the cross sectional area of the duct (4.9 square feet) must be present to allow for the passage of air. This is illustrated in Figure B-1.

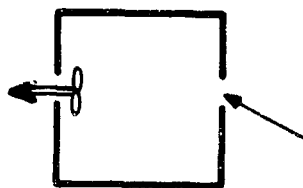

Aperture area at least equal to cross-sectional area of duct.

Fig. B-1

If the aperture area along the route of the air flow is not sufficient to permit the use of the required number of ventilators, the maximum air flow which can be handled by the existing apertures should be computed and the number of ventilators and number of spaces adjusted accordingly.

- 4) When a Kearny pump is used to ventilate a shelter, an aperture area equal to one-half the area of the Kearny pump must be present to allow for the passage of air. The area required is 3.75 square feet for a Type I Kearny

pump and 7.5 square feet for a Type II. This configuration is illustrated below in Figure B-2:

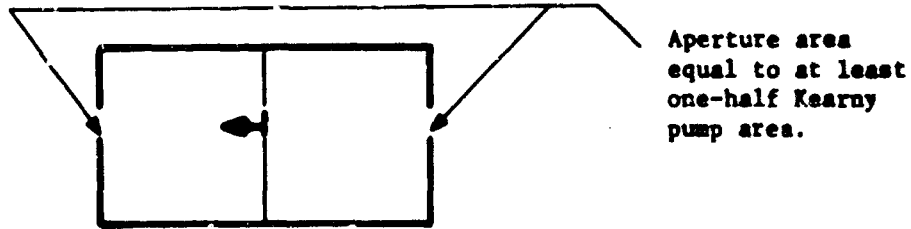

Fig. B-2

If the aperture area along the air flow route is not sufficient to permit the use of the required number of Kearny pumps, the maximum number which can be used with existing apertures should be computed and the spaces adjusted accordingly.

- 5) When it is necessary for air to enter a shelter through apertures remotely located from the ventilator, any apertures which are very close to the ventilator should be closed or opened only slightly. An example is given in Figure B-3.

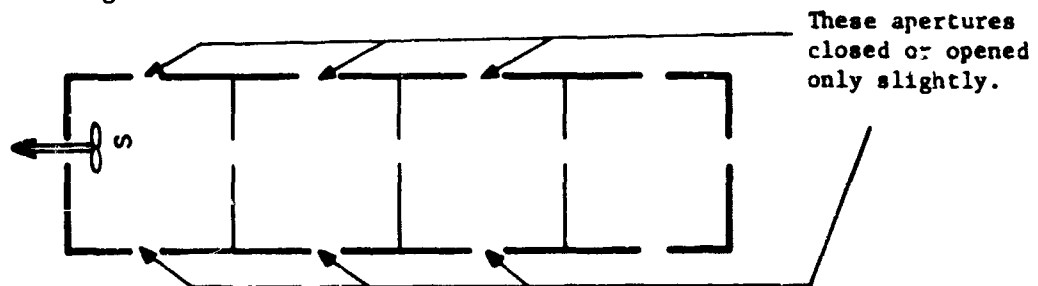

Fig. B-3

- 6) When using stairways or elevator shafts to supply or exhaust air to another story, air should not be drawn from or exhausted to another shelter area. It is also necessary to make sure that air exhausted to another story is not recirculated back into the ventilating system.
- 7) When a Type I (3-foot) Kearny pump is to be used to supply air to a shelter, an aperture with dimensions or at least 3 feet square must be available for use. When a Type II (6-foot) Kearny pump is to be used to supply air to a shelter, a standard doorway must be available for use.
- 8) Kearny pumps are the most desirable ventilators to use because of their low cost and, therefore, should be used when possible. However, it should be noted that Kearny pumps are not applicable in ventilation systems which require long flow paths or which require that the air pass consecutively through several constrictions (e.g., doorways and/or windows). This is due to the rapid decline in Kearny pump capacity for small increases in pressure.



V. VENTILATOR DEPLOYMENT

A. General

The ventilator deployment procedure consists of three specific steps:

- 1) Select the shelter configuration.
- 2) Select the aperture configuration.
- 3) Define the deployment scheme.

In selecting the shelter configuration from those listed below in Section B, the one chosen should most nearly approximate the shelter being considered. Very small rooms such as closets should be ignored in this procedure. Once the shelter configuration is determined, the aperture configuration which most nearly approximates the apertures in the shelter under consideration is selected. The code number listed by each of the configurations is also used to identify recommended deployment procedures in Section C.

The figures used in illustrating the possible deployment schemes are simplified to limit their numbers. Single packaged ventilation kits (PVK's) are shown in many of the illustrations and Kearny pumps are shown to illustrate their use. In many cases, more than one PVK may be needed and the Kearny pumps may or may not be needed depending on the size of the rooms and the aperture locations in the shelter. If more than one PVK is needed, they should be deployed in a manner similar to the one shown in the illustration. Most of the illustrations show exterior wall apertures as means of supplying and exhausting air. If it is necessary or desirable to utilize stairways or elevator shafts in a ventilation system, they may be considered in the same manner as exterior wall apertures. The symbol  is used to identify a packaged ventilation kit (PVK), with the arrow indicating the direction of air flow. The symbol  is used to identify a Kearny pump. An "S" is indicated by the appropriate symbol to identify the equipment that supplies air to the shelter.

B. Codes for Shelter and Aperture Configurations

<u>Code</u>	<u>Configuration</u>
1-A.	Single room.
1.	Multiple apertures per wall in at least two walls directly opposite each other.
2.	Single apertures in two walls directly opposite each other.
3.	Apertures in two adjacent walls.
4.	Multiple apertures in only one wall.
5.	Only one aperture in one wall.

<u>Code</u>	<u>Configuration</u>
I-B.	Single room with one much smaller room.
1.	No apertures in small room.
a.	Apertures in at least two walls directly opposite each other in large room.
b.	Single apertures in two walls directly opposite each other in large room.
c.	Apertures in two adjacent walls of large room.
d.	Multiple apertures in only one wall of large room.
e.	Only one aperture in one wall of large room.
2.	Apertures in small room.
a.	Apertures in the wall of large room directly opposite the wall adjoining the small room.
b.	Multiple apertures per wall in two walls of large room directly opposite each other.
c.	Multiple apertures in only one wall of large room.
d.	No apertures in large room.
I-C.	Winding Corridor.
1.	Apertures in or near each end of corridor.
2.	Apertures in or near one end of corridor and on at least one side.
3.	Apertures in side walls of corridor but not near the ends.
4.	Apertures in or near one end only.
II-A.	Large area with small adjoining rooms.
1.	Apertures in all small rooms and in large area.
2.	Apertures in large area and some of small rooms.
3.	No apertures in small rooms.
a.	Apertures in two walls of large area directly opposite each other.
b.	Apertures in two adjacent walls of large area.
c.	Multiple apertures in only one wall of large area.
d.	Single aperture in one wall of large area.
4.	Apertures in all small rooms, none in large area.
5.	Apertures in some small rooms, none in large area.
III-A.	Partitioned into rooms of comparable size (two rooms).
1.	Apertures in both rooms in wall opposite common wall.
2.	Apertures in both rooms but not in wall opposite common wall.

<u>Code</u>	<u>Configuration</u>
3.	Apertures in one room only.
a.	Multiple apertures in two walls directly opposite each other.
b.	Apertures in two adjacent walls.
c.	Multiple apertures in only one wall.
d.	Single aperture in only one wall.
III-B.	Partitioned into rooms of comparable size (three rooms in series).
1.	Apertures in walls of both end rooms.
2.	Apertures in one end room and in middle room.
3.	Apertures in middle room only.
4.	Apertures in one end room only.
III-C.	Partitioned into rooms of comparable size (three rooms not in series).
1.	Apertures in all three rooms.
2.	Apertures in only two rooms.
3.	Apertures in only one room.
III-D.	Partitioned into rooms of comparable size (four or more rooms in series).
1.	Apertures in both end rooms.
2.	Apertures in one end room and all middle rooms; or in one end room and the middle room adjacent to the other end room.
3.	Apertures in one end room and the adjacent room only, or in one end room only.
4.	Apertures in middle rooms only.
5.	Aperture not in all middle rooms and not in end rooms.
III-E.	Partitioned into rooms of comparable size (four or more rooms not in series).
1.	Apertures in all rooms.
2.	Apertures not in all rooms.
IV-A.	Corridor with rooms off corridor.
i.	Apertures in the corridor and in all or part of the rooms.
2.	Apertures in all or part of rooms but not in corridor.
3.	Apertures in corridor only.
V-A.	Corridor (with rooms off it) joining two large areas.
1.	Apertures in both large areas and in all small rooms.
2.	Apertures in all of the small rooms and none in large areas or corridor.
3.	Apertures in some of the small rooms, but none in corridor and one or both of large areas.

Code Configurations

VI. Complex configuration with large number of rooms that form combinations of the preceding categories.

When this configuration is encountered, the shelter should be divided into parts, each of which conforms to one of the preceding definitions. These parts should then be analyzed separately to determine the ventilation requirements. However, it should be kept in mind that two or more of these parts may be considered together when the ventilation equipment needs and equipment deployment are defined.

C. Deployment Schemes

This section describes recommended deployment of ventilators for the configurations identified in Section B by code number.

Code

I-A-1 Single room shelter with multiple apertures per wall in at least two walls directly opposite each other.

Packaged ventilation kits (PVK's) are used to exhaust air through the apertures on one side and the apertures on the opposite wall are opened to allow fresh air to be drawn in as shown in Figure B-4a. Figure B-4b shows the same configuration using Kearny pumps in the apertures

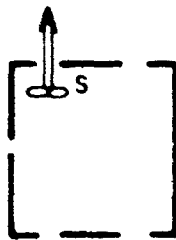

Fig. B-4a

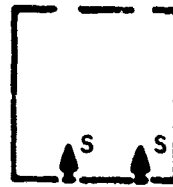

Fig. B-4b

Code

I-A-2 Single room shelter with single apertures in two walls directly opposite each other.

PVK's are positioned at the aperture on one side of the shelter to exhaust air and the aperture on the opposite side allows the entrance of fresh air. In this situation, it is doubtful that the fresh air would be properly distributed through the shelter using only the PVK if the room is very large. Kearny pumps may be utilized to provide proper distribution of the fresh air. Figure B-5a shows an example of this situation. Figure B-5b shows the same configuration using a Kearny pump to supply air to the shelter.

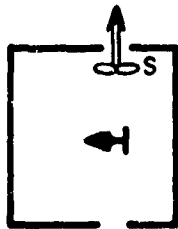

Fig. B-5a

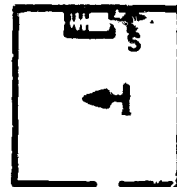

Fig. B-5b

I-A-3 Single room shelter with apertures in two adjacent walls.

In this case, a packaged ventilation kit (PVK) or a Kearny pump may be used to supply air to the shelter. It will probably be necessary to use Kearny pumps to obtain adequate air distribution within the shelter. Examples of the configuration using a PVK and using a Kearny pump are given below in Figures B-6a and B-6b, respectively

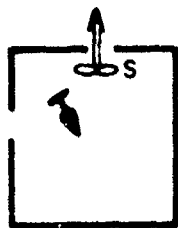

Fig. B-6a



Fig. B-6b

Code

I-A-4 Single room shelter with multiple apertures in only one wall.

One opening is used to supply air with a packaged ventilation kit (PVK) or Kearny pump and the other(s) are used to allow air to exhaust. Kearny pumps are used to provide fresh air distribution throughout the shelter. Examples are shown in Figures B-7a and B-7b. If Kearny pumps cannot be used to supply air to the shelter and a PVK cannot be used as a supply blower, the PVK may be placed in a remote corner of the shelter and the duct passed through one of the apertures. This is illustrated in Figure B-7c.

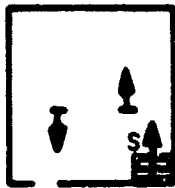

Fig. B-7a

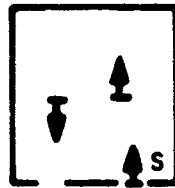

Fig. B-7b

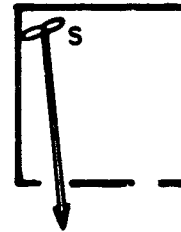

Fig. B-7c

I-A-5 Single room shelter with only one aperture in one wall.

In this case, the only means by which air may be supplied is to position the PVK in a remote corner of the shelter and have the duct pass out through the opening and extend for 50 feet beyond the opening. The remaining portion of the opening allows fresh air to enter. An example is shown in Figure B-8.

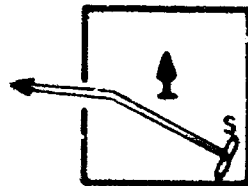

Fig. B-8

Code

1-B-1a Single room with one much smaller room. No apertures in small room.
Apertures in at least two walls directly opposite each other in large room.

Ventilator(s) are used to exhaust air through the apertures in one side of the large room and the apertures on the opposite side allow fresh air to enter. The small room is ventilated by placing a 3-foot Kearny pump in the doorway connecting the two rooms, if only a single doorway exists. If two doors exist, a 6-foot Kearny pump could be used, if needed, in one doorway and the other doorway used to return air to the larger room. Figures B-9a and B-9b illustrate the configuration using both PVK ventilators and Kearny pumps to supply air. If the apertures serving as sources of supply air are located at one extreme end of the wall, the configuration is considered under Code 1-B-1b.

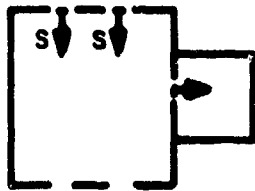

Fig. B-9a

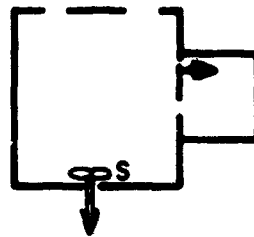

Fig. B-9b

Code

I-B-1b

Single room with one much smaller room. No apertures in small room.

Single apertures in two walls directly opposite each other in large room.

The opening in one wall is used to exhaust air by using a Kearny pump or a PVK while the opening in the opposite wall allows fresh air to enter. Three-foot Kearny pumps are used to mix the air in the large room, if necessary, and a Kearny pump is placed in the doorway connecting the two rooms to supply air to the small room. Figures B-10a and B-10b illustrate this configuration using a PVK and a Kearny pump, respectively, as means of supplying air to the shelter

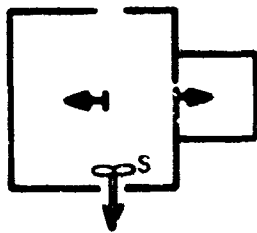

Fig. B-10a

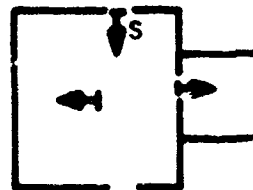

Fig. B-10b

Code

I-B-1c Single room with one much smaller room. No apertures in small room. Apertures in two adjacent walls of large room.

This configuration is ventilated by using a Kearny pump or a PVK to pull in fresh air through the apertures in one wall while allowing air to exhaust through the apertures in the other wall. Kearny pumps are used to obtain proper mixing in the large room, if needed, and a Kearny pump is placed in the doorway connecting the two rooms to provide ventilation to the small room. Figures B-11a and B-11b illustrate the system using both sources of supply.

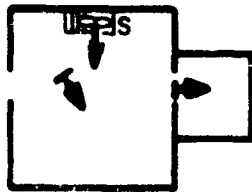

Fig. B-11a

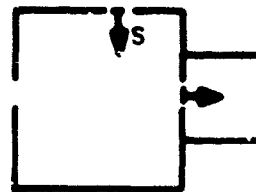

Fig. B-11b

I-B-1d Single room with one much smaller room. No apertures in small room. Multiple apertures in only one wall of large room.

A Kearny pump or a PVK is positioned at one opening and air is exhausted through the remaining apertures. Kearny pumps are used to mix the air in the large room, if needed, and a Kearny pump is placed in the doorway connecting the two rooms to ventilate the small room. Figures B-12a and B-12b illustrate this case. If neither a supply blower nor a Kearny pump can be used, a PVK may be placed in a remote corner of the large room or in the small room and the duct passed through one of the apertures. This is illustrated in Figure B-12c.

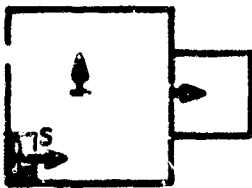

Fig. B-12a

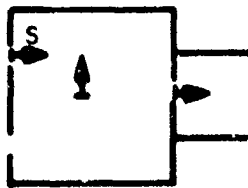

Fig. B-12b

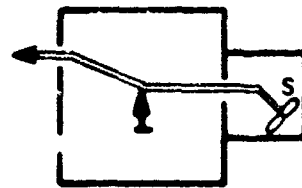

Fig. B-12c

Code

I-B-1e

Single room with one much smaller room. No apertures in small room.

Only one aperture in one wall of large room.

The single aperture must be used both to supply and to exhaust air. It is, therefore, necessary to locate the PVK in a remote corner of the large room or to locate it in the small room. Kearny pumps may be used to mix the air, and to supply air to the small room if the PVK is in the large room. Figures B-13a and B-13b illustrate two possible deployment plans.

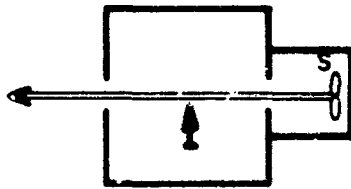

Fig. B-13a

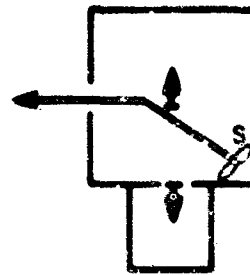

Fig. B-13b

Code

I-B-2a

Single room with one much smaller room. Apertures in small room.

Apertures in the wall of large room directly opposite the wall adjoining the small room.

The packaged ventilation kit (PVK) may be used to exhaust air through the aperture in the large room wall or it may be used to exhaust air through the small room aperture. If there are no apertures in the large room walls other than the wall directly opposite the wall adjoining the small room, Kearny pumps may need to be placed in the large room to obtain proper mixing of the air. If apertures exist in only one wall of the small room, it may be necessary to use a Kearny pump for mixing the air in the small room. If apertures occur in more than one wall of both rooms, Kearny pumps may not be necessary. Figures B-14a and B-14b illustrate possible deployment plans. This configuration may also be ventilated using a Kearny pump as the means of supplying air to the shelter. Figures B-14c and B-14d illustrate two possible means by which this may be done. Kearny pumps mounted in this way do not prevent movement of personnel from one room to another since their operation may be temporarily stopped for this purpose.

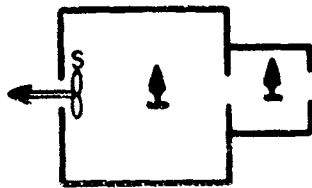

Fig. B-14a

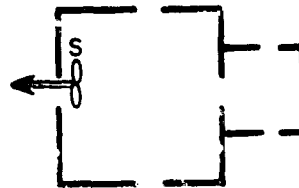

Fig. B-14b

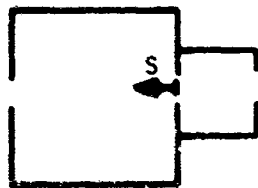

Fig. B-14c

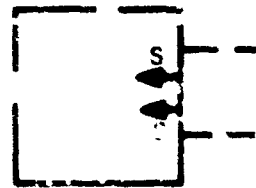

Fig. B-14d

Code

I-B-2b

Single room with one much smaller room. Apertures in small room.

Multiple apertures per wall in two walls of large room directly opposite each other.

Air is exhausted through the apertures of one wall of the large room and fresh air enters through the apertures in the opposite wall and through the apertures in the small room. If apertures exist in only one wall of the small room, it may be necessary to use a Kearny pump in the small room to obtain proper air mixing. Figure B-15a illustrates the procedure using a PVK. Figure B-15b illustrates a means of supplying air to a shelter of this configuration by using a Kearny pump.

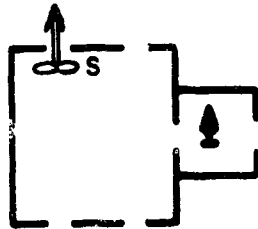

Fig. B-15a

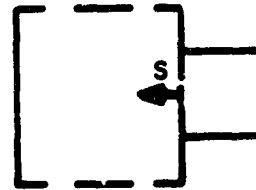

Fig. B-15b

Code

I-B-2c Single room with one much smaller room. Apertures in small room.
Multiple apertures in only one wall of large room.

This configuration may be ventilated using either a supply system or an exhaust system. With an exhaust system, air is exhausted through the apertures in the large room and supplied through the apertures in the small room. Kearny pumps may be used to obtain proper mixing. This is illustrated in Figure B-16a. With a supply system, air could be supplied through the large room apertures and allowed to exhaust through the remaining apertures in the large room and/or the apertures in the small room as illustrated in Figures B-16b and B-16c. Figure B-16d illustrates how a Kearny pump may be utilized to supply air to a shelter of this configuration.

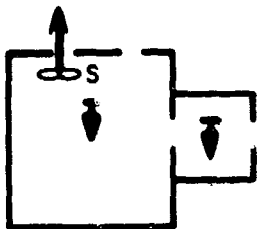

Fig. B-16a

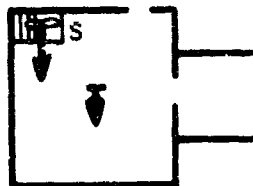

Fig. B-16b

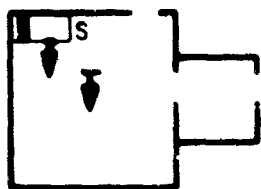

Fig. B-16c

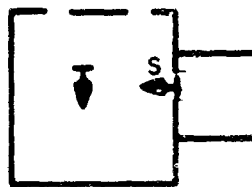

Fig. B-16d

I-B-2d Single room with one much smaller room. Apertures in small room.
No apertures in large room.

The method for ventilating this configuration depends on the size of the large room and the number of doorways connecting the large and small rooms. If only one doorway exists between the two rooms, the

Code

I-B-2d
Cont'd.

maximum air flow which can be provided to the large room is 460 CFM using a 3-foot Kearny pump. If two doorways exist between the two rooms, a 6-foot Kearny pump placed in one doorway can provide up to 3700 CFM of air to the large room. If the large room requires an air flow greater than these values, the PVK may be placed in a remote corner of the large room and the duct passed through the connecting doorway and out through the apertures in the small room. Figures B-17a, B-17b, and B-17c illustrate three possible deployment plans.

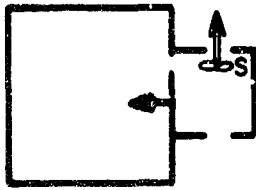

Fig. B-17a

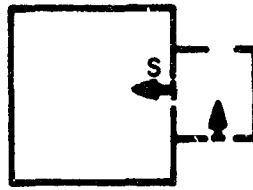

Fig. B-17b

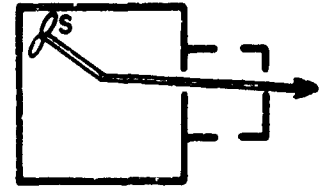

Fig. B-17c

I-C-1

Winding corridor. Apertures in or near each end of corridor.

A PVK or a Kearny pump is placed at one end of the corridor to exhaust air and the apertures on the other end of the corridor allow fresh air to enter. This is illustrated in Figure B-18.



Fig. B-18

I-C-2

Winding corridor. Apertures in or near one end of corridor and on at least one side.

The PVK is placed in the end of the corridor with no apertures and the duct passed through the aperture in the side wall of the corridor as shown in Figure B-19.

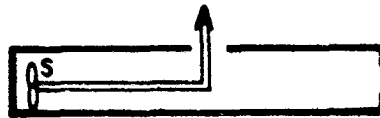

Fig. B-19

Code

I-C-3

Winding Corridor. Apertures in side walls of corridor but not near the ends.

This configuration requires PVKs to be placed in both ends of the corridor and the ducts to be run out through the apertures as illustrated in Figure B-20.

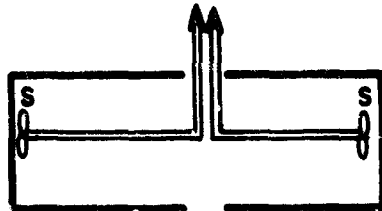

Fig. B-20

I-C-4

Winding corridor. Apertures in or near one end only.

A PVK is placed in the end of the corridor with no apertures and the duct run the entire length of the corridor to the aperture as shown in Figure B-21.

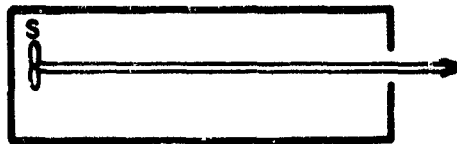

Fig. B-21

Code

II-A-1

Large area with small adjoining rooms. Apertures in all small rooms and in large area.

PVK ventilators used as exhaust blowers are placed in the large room. Air enters through the apertures in the small rooms and those apertures in the large room not used for exhaust. If the apertures in the small rooms are limited in number, it may be necessary to use Kearny pumps to obtain proper mixing of the air. The same is true for the large room. Figure B-22a shows a possible ventilation plan. Kearny pumps may be used to supply air to a shelter of this configuration by mounting them in the doorways connecting the small rooms to the large area as illustrated in Figure B-22b.

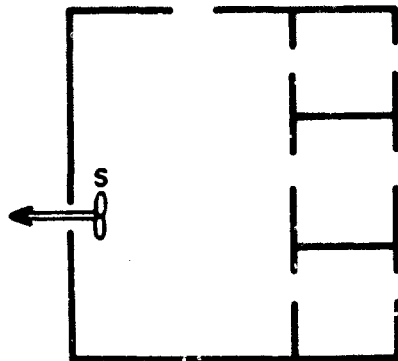

Fig. B-22a

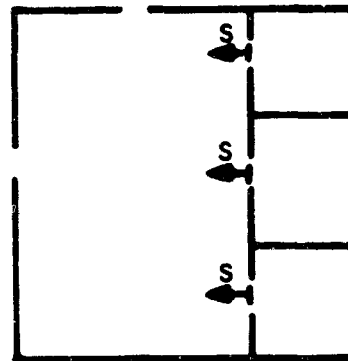

Fig. B-22b

Code

II-A-2 Large area with small adjoining rooms. Apertures in large area and some of small rooms.

PVK's used as exhaust blowers are placed in the large area and air enters through the apertures in the large area and those small rooms which have them. Kearny pumps are used in the large room for mixing if limited apertures exist, and Kearny pumps are used to ventilate those small rooms which do not have apertures. If apertures in the small rooms are limited, Kearny pumps are used for mixing air in those rooms. One scheme is shown in Figure B-23a using a PVK and Figure B-23b illustrates the use of Kearny pumps to supply air.

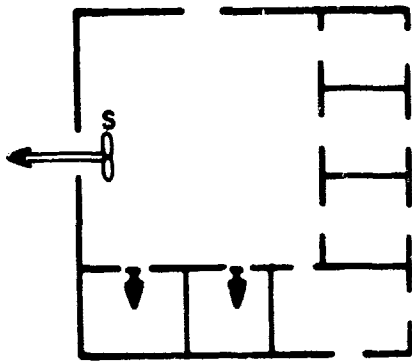

Fig. B-23a

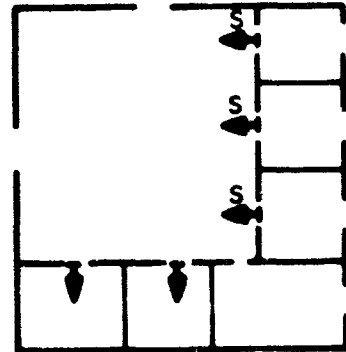

Fig. B-23b

Code

II-A-3a Large area with small adjoining rooms. No apertures in small rooms.
Apertures in two walls of large area directly opposite each other.

PVK's are used to exhaust air through the apertures in one wall and air enters the apertures in the opposite wall. If the apertures are not distributed along the entire wall, it may be necessary to use Kearny pumps to obtain proper air mixing. Kearny pumps would also be used to ventilate the small rooms as illustrated in Figure B-24.

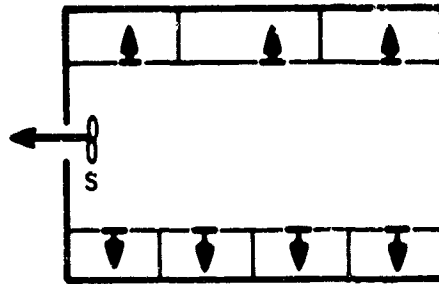

Fig. B-24

II-A-3b Large area with small adjoining rooms. No apertures in small rooms.
Apertures in two adjacent walls of large area.

This configuration may be ventilated using either a PVK or Kearny pump in an aperture of one wall of the large room while the apertures in the other wall permit stale air to pass out. Kearny pumps are utilized to mix the air in the large room, if needed, and are used to ventilate the small rooms. Figure B-25 illustrates the system.

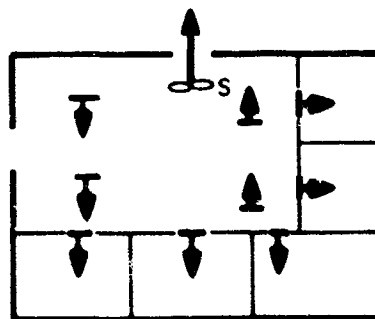

Fig. B-25

Code

II-A-3c Large area with small adjoining rooms. No apertures in small rooms.
Multiple apertures in only one wall of large area.

Kearny pumps or PVK's used as supply blowers are used in part of the apertures and stale air is exhausted through the remaining apertures. Kearny pumps are used both for mixing the air in the large area and for ventilating the small rooms as illustrated in Figure B-26a. If neither a PVK nor a Kearny pump can be used as a supply system, a PVK may be located in a remote corner of the large area or in a remote small room and the duct passed through the apertures. An illustration is given in Figure B-26b.

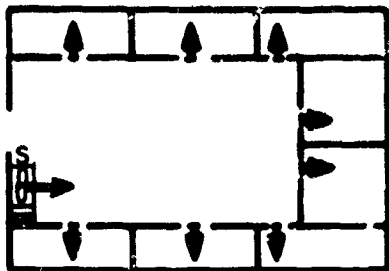

Fig. B-26a

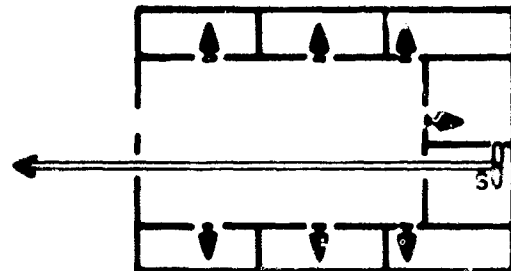

Fig. B-26b

II-A-3d Large area with small adjoining rooms. No apertures in small rooms.
Single aperture in one wall of large area.

PVK's are located in a remote corner of the large room or in a remote small room. The duct is passed through the aperture and fresh air enters through the remaining portion of the aperture. Kearny pumps are used for mixing air in the large area and to ventilate small rooms. An illustration is given in Figure B-27.

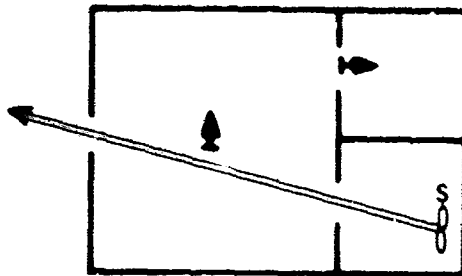

Fig. B-27

Code

II-A-4

Large area with small adjoining rooms. Apertures in all small rooms, none in large area.

If the small adjoining rooms occur on more than one side of the large area, PVK's used as exhaust blowers could be placed in one or more of the small rooms and fresh air would enter through the remaining small rooms. Kearny pumps could be used to mix the air in the large area, if needed. If small rooms are on two opposite sides of the large area, the Kearny pumps may not be required. If small rooms are on only one side of the large area, it may be necessary to locate the PVK in a remote corner of the large area and pass the duct through the apertures in a small room. The apertures in the remaining small rooms allow fresh air to enter. Figures B-28a and B-28b illustrate two configurations. Kearny pumps may also be utilized to supply air to a shelter of this configuration as illustrated in Figures B-28c and B-28d.

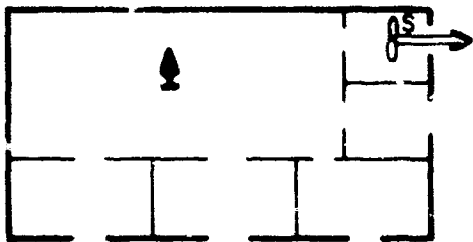

Fig. B-28a

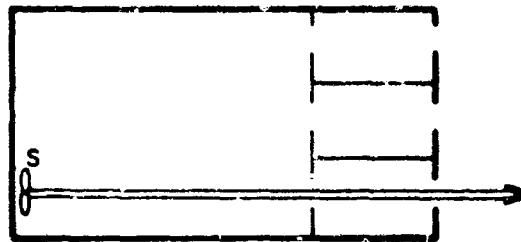

Fig. B-28b

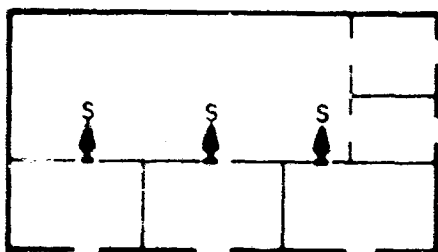

Fig. B-28c

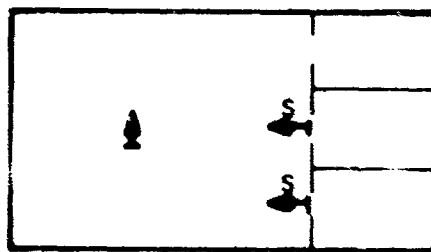

Fig. B-28d

Code

II-A-5

Large area with small adjoining rooms. Apertures in some small rooms, none in large area.

If this configuration has rooms on more than one side of the large area, and one or more rooms on each side of the large area have apertures, ventilation may be provided by using PVK's as exhaust blowers in one or more small rooms and allowing fresh air to enter through the remaining small rooms. Kearny pumps could be used to mix the air in the large area and to ventilate those small rooms which have no apertures (Figure B-29a). If rooms occur on only one side of the large area or if the rooms with apertures are all on the same side of the large area, it would be beneficial to use a PVK as a supply ventilator, if possible, in one of the small rooms, allowing air to exit through the other small rooms. Kearny pumps could be used to mix the air in the large area and to ventilate the small rooms with no apertures as shown in Figure 29b. The use of Kearny pumps to supply air to this configuration is illustrated in Figures B-29c and B-29d.

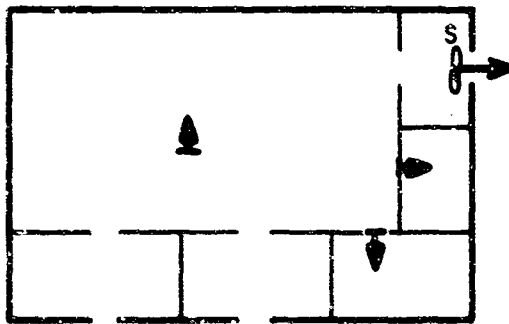

Fig. B-29a

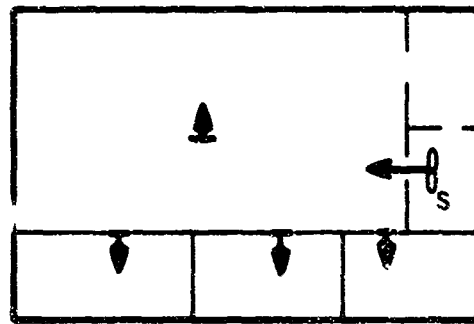

Fig. B-29b

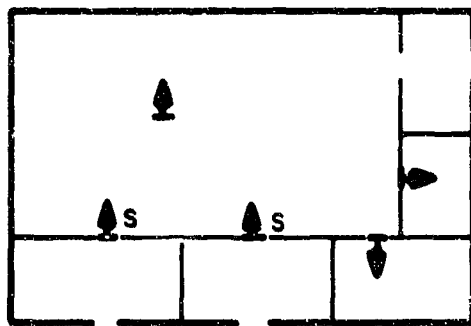

Fig. B-29c

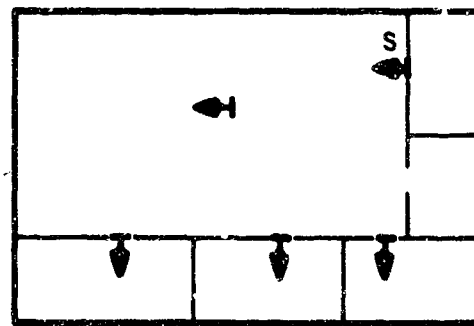

Fig. B-29d

Code

III-A-1 Partitioned into rooms of comparable size (two rooms). Apertures in both rooms in wall opposite common wall.

PVK's could be placed in one room to exhaust air through the apertures and fresh air could enter through the apertures in the second room. If apertures are not distributed along the entire wall and none appear in other walls, it may be necessary to use Kearny pumps to obtain proper air distribution. Two cases are shown in Figures B-30a and B-30b. Figures B-30c and B-30d illustrate the use of Kearny pumps to supply air to a shelter of this configuration.

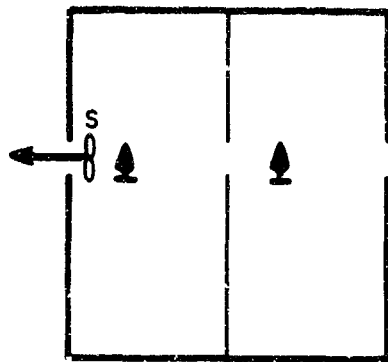

Fig. B-30a

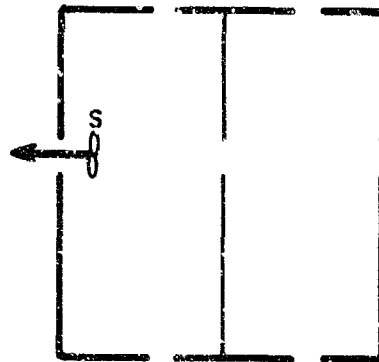

Fig. B-30b

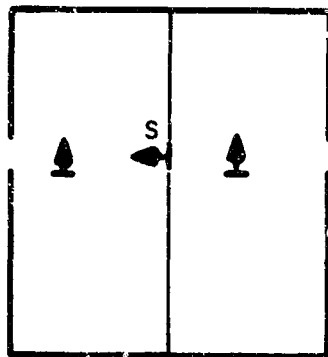

Fig. B-30c

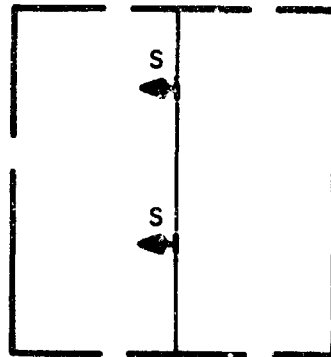

Fig. B-30d

III-A-2 Partitioned into rooms of comparable size (two rooms). Apertures in both rooms but not in wall opposite common wall.

Depending on the number and distribution of apertures, several possibilities exist for this configuration. If several apertures exist in all walls other than those opposite the common wall, an exhaust system in one room with fresh air coming through the other apertures in that room and from the second room could adequately ventilate the rooms although it may be necessary to use Kearny pumps for mixing the air in the supply room (Figure B-31a). If apertures are very limited in number or not distributed adequately, a PVK used as a supply blower in one room with air exhausting through the second room may be more desirable when feasible. Kearny pumps may be used to mix the air in both rooms (Figure B-31b). Figure B-31c illustrates the use of Kearny pumps to ventilate this configuration.

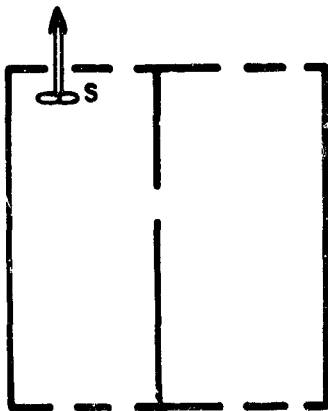

Fig. B-31a

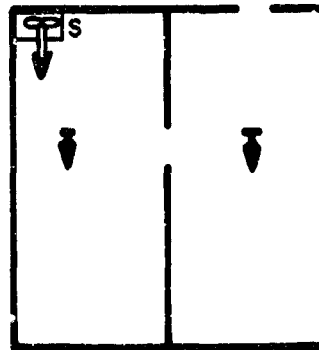

Fig. B-31b

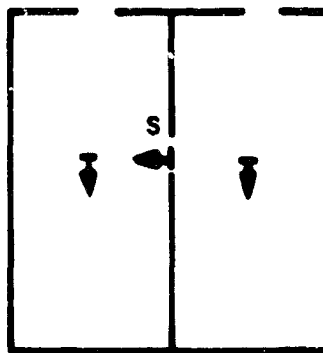

Fig. B-31c

Code

III-A-3a Partitioned into rooms of comparable size (two rooms). Apertures in one room only. Multiple apertures in two walls directly opposite each other.

Ventilation of this configuration depends on the size of the room with no apertures and the number of doorways between the two rooms. If a single doorway exists between the two rooms and the air flow required for the windowless room is less than 460 CFM, or if two doorways exist between the two rooms and the air flow required is less than 3700 CFM, the shelter may be ventilated using a PVK or a Kearny pump. Fresh air enters through the remaining apertures in the room. The second room is then ventilated using a 3-foot Kearny pump if a single doorway exists or using a 6-foot Kearny pump if two doorways exist. This is illustrated in Figures B-32a and B-32c.

If the size of the room is too great to be ventilated by a Kearny pump, a PVK is located in a remote corner of the room with no apertures and the duct is passed through the doorway connecting the two rooms and out through the apertures in the other room. Kearny pumps are used to mix the air in the room with no apertures. A second PVK could be located in the room with apertures, if needed (Figure B-32b).

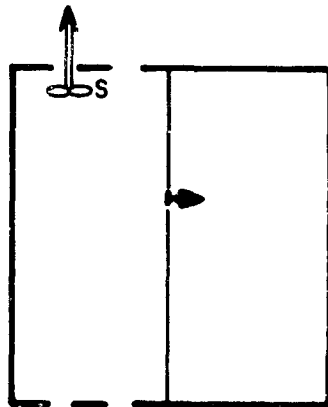

Fig. B-32a

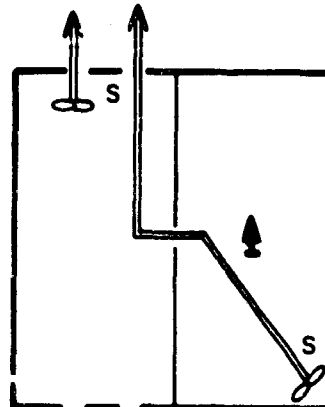

Fig. B-32b

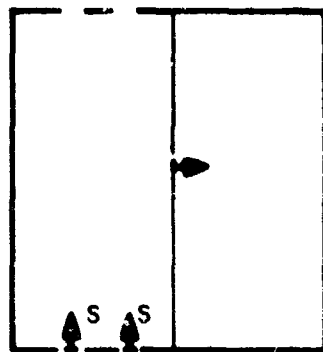

Fig. B-32c

Code

III-A-3b Partitioned into rooms of comparable size (two rooms). Apertures in one room only. Apertures in two adjacent walls.

If the room with no apertures is small enough, it may be ventilated by a Kearny pump (460 CFM for single doorways and a 3-foot Kearny pump, 3700 CFM for two doorways and a 6-foot Kearny pump). A PVK or Kearny pump may be used in the apertures of one wall with stale air exhausting through the remaining apertures. Kearny pumps could be used to mix the air in the room with apertures and to supply air to the other room (Figures B-33a and B-33b).

If the room with no apertures is too large to be ventilated with a Kearny pump, a PVK could be located in the room with no apertures with the duct extended through the doorway connecting the two rooms and out through the apertures. Kearny pumps could be used to mix the air in both rooms as shown in Figure B-33c.

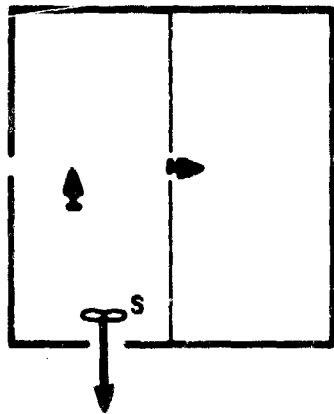

Fig. B-33a

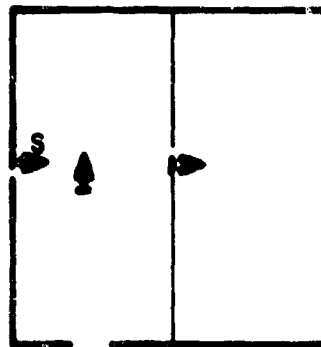

Fig. B-33b

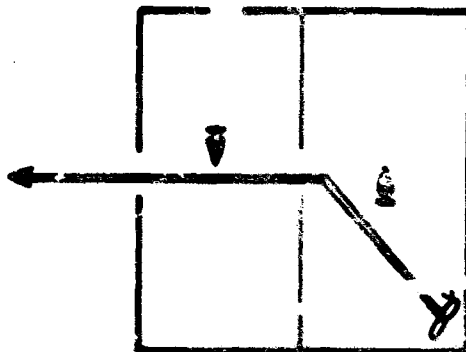

Fig. B-33c

Code

III-A-3c Partitioned into rooms of comparable size (two rooms). Apertures in one room only. Multiple apertures in only one wall.

If the ventilation requirement of the room with no apertures is sufficiently small to be supplied by a Kearny pump (460 CFM for one doorway and a 3-foot Kearny pump or 3700 CFM for two doorways and a 6-foot Kearny pump), a Kearny pump may be placed at one or more apertures and air allowed to exhaust through the remaining aperture(s). Kearny pumps could be utilized to mix the air in the room with apertures and would supply air to the room with no apertures. If the ventilation requirement of the room with no apertures is too great to be supplied by a Kearny pump, a PVK could be located in a remote corner of the room with no apertures and the duct passed through the connecting doorway and out through the apertures. Kearny pumps could be used to mix the air in both rooms, if needed. Figures B-34a and B-34b illustrate these cases.

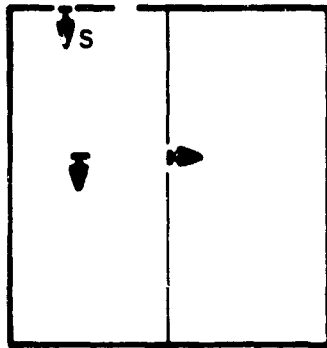

Fig. B-34a

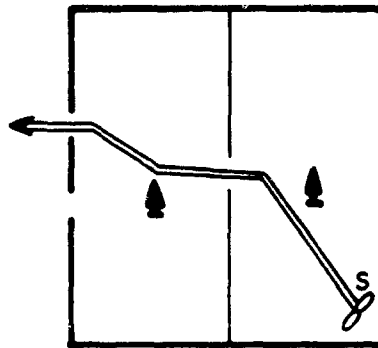

Fig. B-34b

Code

III-A-3d Partitioned into rooms of comparable size (two rooms). Apertures in one room only. Single aperture in only one wall.

A PVK is placed in a remote corner of the room with no apertures and the duct passed through the connecting doorway and out through the aperture. Kearny pumps are utilized to mix the air in each room, if needed (Figure B-35a).

If the single aperture is positioned such that air does not flow through both rooms (Figure B-35b), two PVK's may be used. If the room with no apertures is sufficiently small, a single PVK may be placed in a remote corner of the room with the aperture and the windowless room ventilated with a Kearny pump (Figure B-35c).

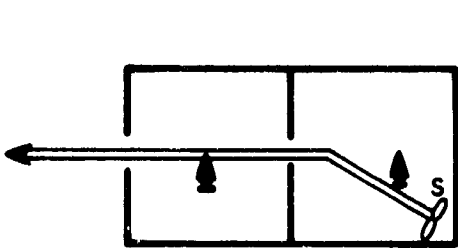

Fig. B-35a

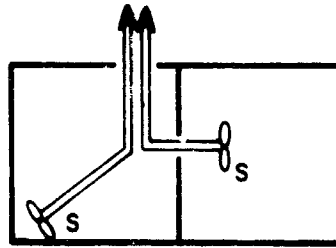

Fig. B-35b

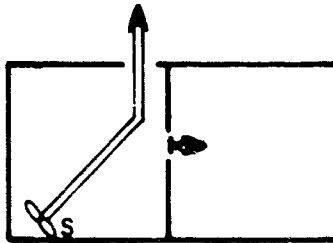

Fig. B-35c

Code

III-B-1 Partitioned into rooms of comparable size (three rooms in series).
Apertures in walls of both end rooms.

A PVK is located in one end room and air enters the apertures in the other end room and passes through the center room (Figure B-36a). Kearny pumps may be used to mix the air in the center room and the end rooms if apertures do not exist on the sides and air mixing is required. Figures B-36b and B-36c illustrate the use of Kearny pumps to supply air for this configuration.

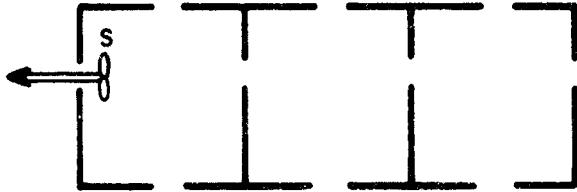

Fig. B-36a

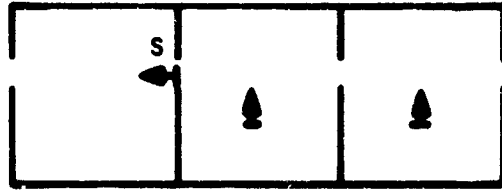

Fig. B-36b

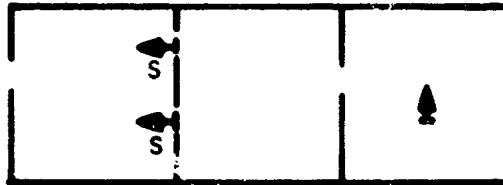

Fig. B-36c

Code

III-B-2 Partitioned into rooms of comparable size (three rooms in series).
Apertures in one end room and in middle room.

If the end room with no apertures requires sufficiently little air to be ventilated with a Kearny pump, a PVK can be placed in either the center room or the other end room and air allowed to enter through the remaining room. Kearny pumps may be used to mix the air in these rooms and to supply air to the end room with no apertures (Figure B-37a). If the ventilation requirement of the room with no apertures is too great to be supplied with a Kearny pump, a PVK may be placed in a remote corner of this room and the duct passed through the apertures in the center room (Figure B-37b). Kearny pumps could be used for mixing the air. Figure B-37c illustrates the use of a Kearny pump to supply air for this configuration.

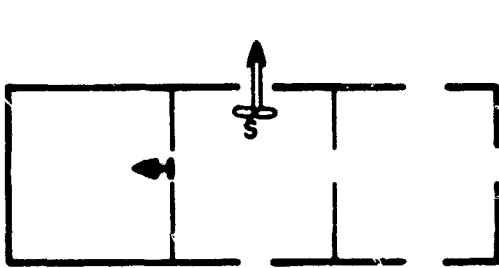

Fig. B-37a

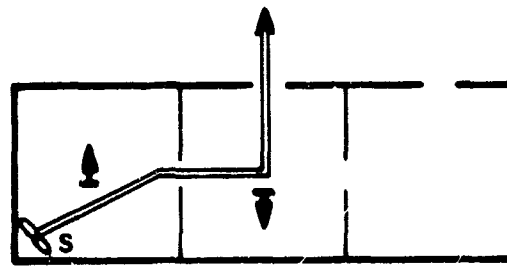

Fig. B-37b

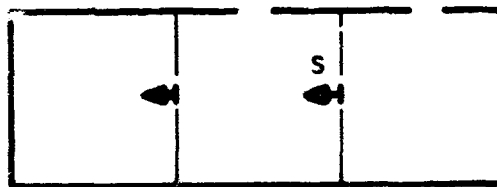

Fig. B-37c

Code

III-B-3 Partitioned into rooms of comparable size (three rooms in series).
Apertures in middle room only.

If the center room has apertures on two sides, a PVK or Kearny pump may be used to supply air and the two end rooms can be ventilated with Kearny pumps (Figure B-38a). If the center room has apertures on only one side and a Kearny pump cannot be used, a PVK should be used, if possible, with Kearny pumps to mix the air in the center room and to supply air to the end rooms (Figure B-38b). If the end rooms require more air than can be provided with Kearny pumps, PVK's may be located in the remote corners of these rooms and the ducts passed through the center room apertures (Figure B-38c). Kearny pumps could be used for proper air mixing. Figures B-38d and B-38e give examples using Kearny pumps to supply as well as mix air.

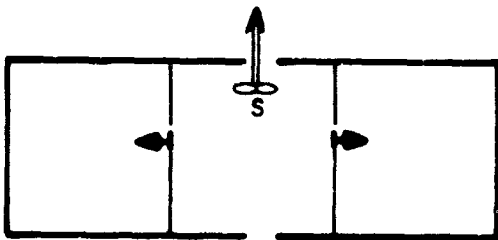

Fig. B-38a

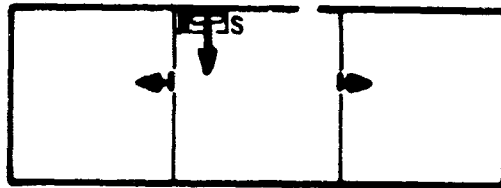

Fig. B-38b

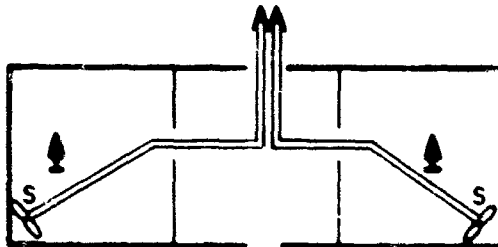

Fig. B-38c

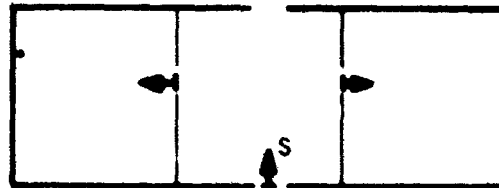

Fig. B-38d

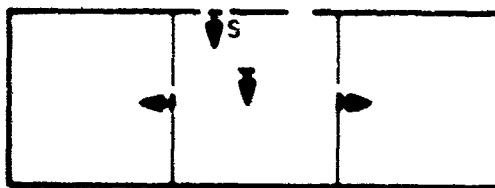

Fig. B-38e

Code

III-B-4 Partitioned into rooms of comparable size (three rooms in series).

Apertures in one end room only.

PVK's used as exhaust blowers are placed in the end room with no apertures and the duct is passed through the center room and out the apertures in the other end room. Kearny pumps may be used to obtain proper mixing. An illustration is given in Figure B-39.

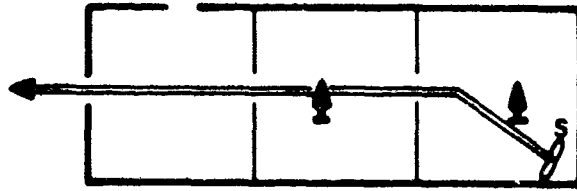

Fig. B-39

Code

III-C-1 Partitioned into rooms of comparable size (three rooms not in series).
Apertures in all three rooms.

PVK's used to exhaust air can be placed in any of the rooms. Figures B-40a and B-40b illustrate two possibilities. Kearny pumps are used for mixing the air, when needed. These same configurations could be ventilated using Kearny pumps to supply air as shown in Figures B-40c and B-40d.

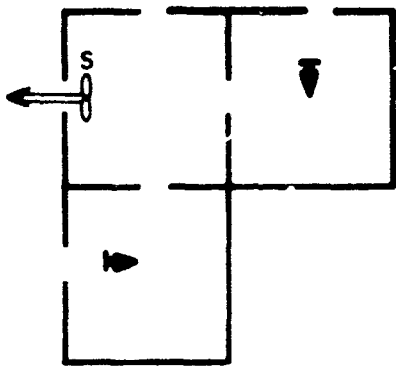

Fig. B-40a

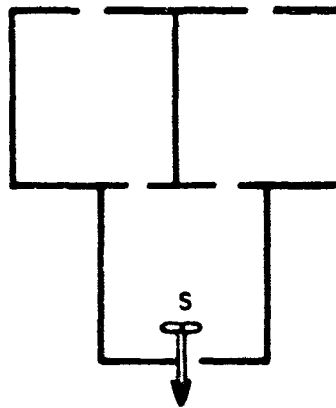

Fig. B-40b

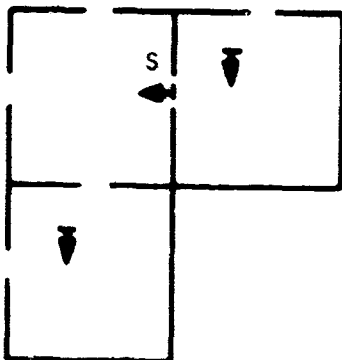

Fig. B-40c

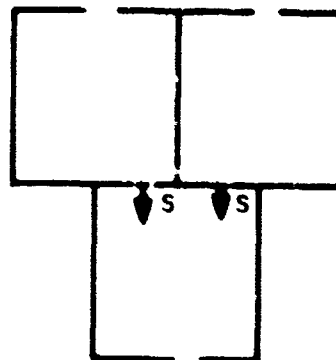

Fig. B-40d

Code

III-C-2 Partitioned into rooms of comparable size (three rooms not in series).
Apertures in only two rooms.

PVK's are placed such that air flows through all three rooms, if possible, as illustrated in Figure B-41a. If this is not possible, the room with no apertures may be ventilated with a Kearny pump if it is sufficiently small (Figure B-41b). If the room with no apertures cannot be adequately ventilated with a Kearny pump, a PVK is placed in the windowless room. The duct is passed through the connecting doorway into the adjoining room and then out through the apertures in that room (Figure B-41c). Figure B-41d illustrates the use of a Kearny pump to supply air in this configuration.

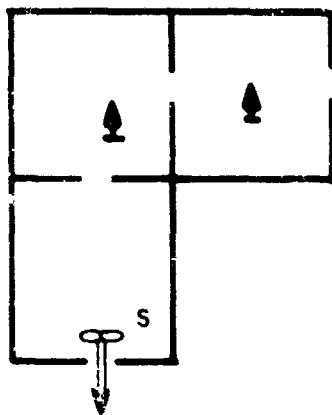

Fig. B-41a

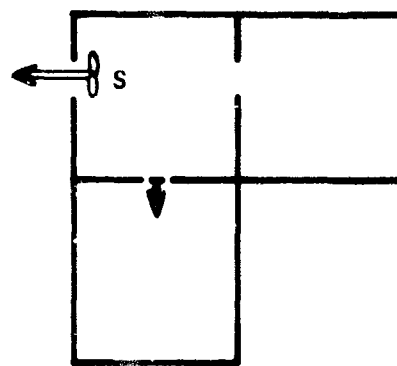

Fig. B-41b

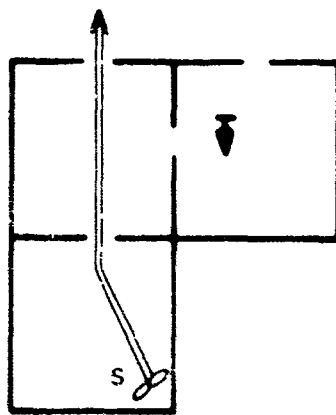

Fig. b-41c

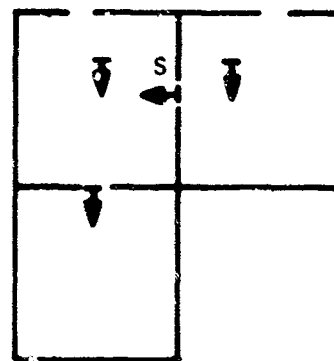

Fig. B-41d

Code

III-C-3 Partitioned into rooms of comparable size (three rooms not in series).
Apertures in only one room.

If the two windowless rooms are both adjacent to the room with apertures and both are sufficiently small to be ventilated with Kearny pumps, the room with apertures is ventilated as a single room shelter and Kearny pumps used to ventilate the windowless rooms (Figure B-42a). If these rooms are not sufficiently small to be ventilated by Kearny pumps, PVK's are placed in these rooms and the ducts passed through the connecting doorways and out through the apertures in the adjoining room (Figure B-42b).

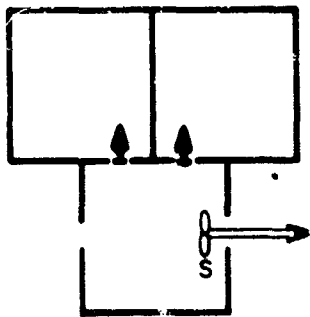

Fig. B-42a

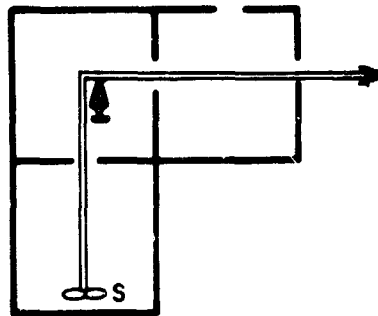

Fig. B-42b

Code:

III-D-1 Partitioned into rooms of comparable size (four or more rooms in series).

Apertures in both end rooms.

PVK's are placed in one of the end rooms and air enters through the apertures in the other rooms and passes through the connecting rooms (Figure B-43a). If no apertures are present in the walls of the middle rooms, Kearny pumps may be needed to mix the air in these rooms (Figure B-43b). Figure B-43c illustrates the use of Kearny pumps to supply air for this configuration.

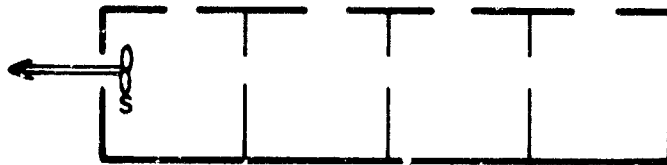

Fig. B-43a

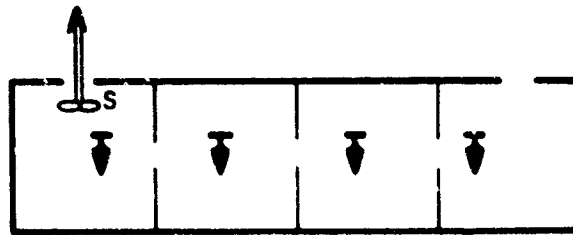

Fig. B-43b

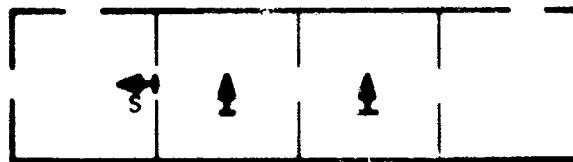

Fig. B-43c

Code

III-D-2 Partitioned into rooms of comparable size (four or more rooms in series).
Apertures in one end room and all middle rooms; or in one end room and the
middle room adjacent to the other end room.

For four rooms, as described in Figure B-44a, a PVK could be placed in the middle room adjacent to the windowless end room and this end room ventilated with a Kearny pump if it is sufficiently small. If the end room is not small enough to ventilate with a Kearny pump, the PVK is placed in the end room and the duct passed through the apertures in the next room (Figure B-44b). Figure B-44c illustrates this configuration ventilated with Kearny pumps.

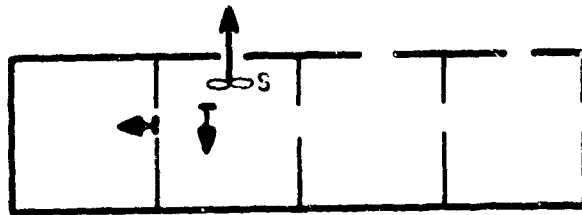

Fig. B-44a

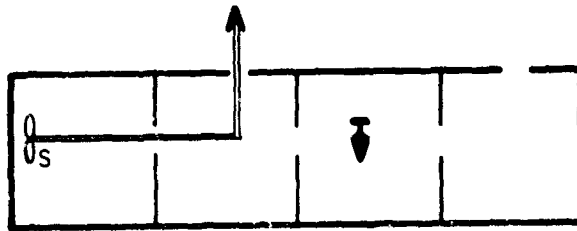

Fig. B-44b

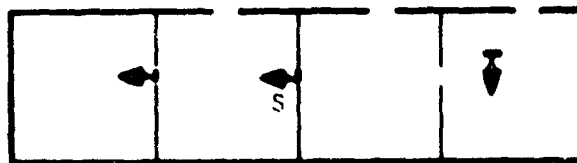

Fig. B-44c

Code

III-D-3 Partitioned into rooms of comparable size (four or more rooms in series).
Apertures in one end room and the adjacent room only, or in one end room
only.

In this case, it is necessary to place a PVK in the windowless end room and pass the duct through the adjoining rooms and out through the nearest apertures. Figures B-45a and B-45b illustrate possible deployment plans. Kearny pumps may be required in the rooms without apertures to distribute the air.

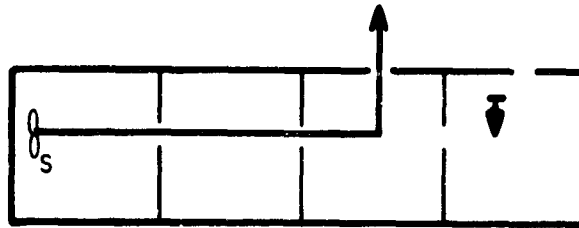

Fig. B-45a

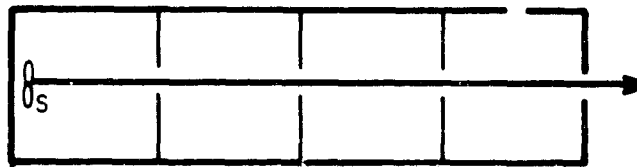

Fig. B-45b

Code

III-D-4 Partitioned into rooms of comparable size (four or more rooms in series).
Apertures in middle rooms only.

For four rooms, a PVK is located in one of the middle rooms and air enters through the other room. The two end rooms could be ventilated with Kearny pumps if they are sufficiently small (Figure B-46a). If the end rooms are not small enough to be ventilated with Kearny pumps, PVK's could be placed in the end rooms and the ducts passed out through the nearest apertures (Figure B-46b). Kearny pumps could be used to obtain proper mixing if needed. Figure B-46c shows the use of Kearny pumps as supply devices.

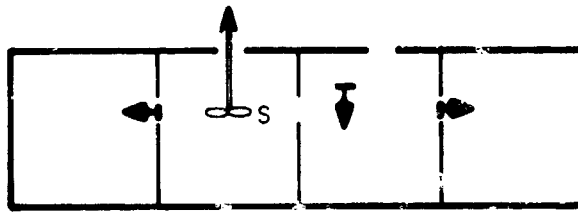

Fig. B-46a

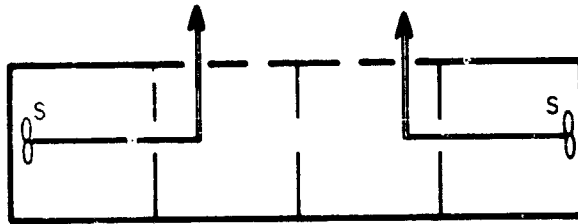

Fig. B-46b

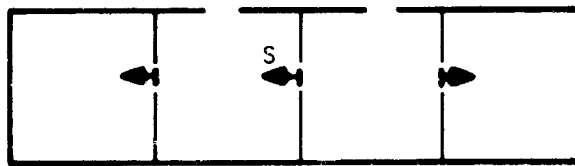

Fig. B-46c

Code

III-D-5 Partitioned into rooms of comparable size (four or more rooms in series).
Apertures not in all middle rooms and none in end rooms.

A PVK is placed in the end room farthest away from the room with apertures and the duct is passed through an aperture. The other end room is ventilated with a Kearny pump if it is sufficiently small. Otherwise, another PVK is placed in the end room and the duct passed through an aperture in the adjoining room. Figures B-47a and B-47b illustrate these cases. These examples show four rooms but the same procedures apply to more than four rooms.

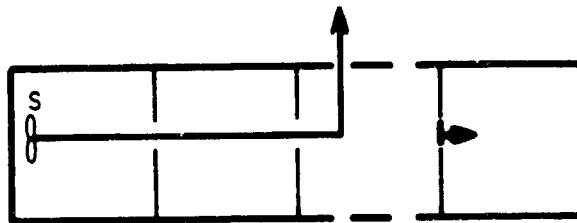

Fig. B-47a

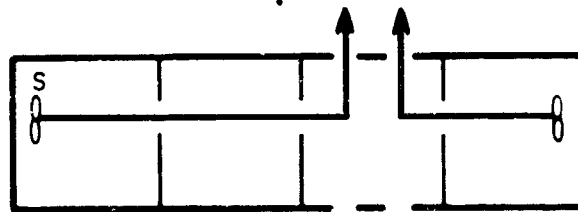

Fig. B-47b

Code

III-E-1 Partitioned into rooms of comparable size (four or more rooms not in series. Apertures in all rooms.

PVK's used as exhaust blowers are placed in a room or rooms and air allowed to enter through the remaining rooms. Figures B-48a, B-48b, and B-48c give three possibilities. Each of the configurations shown could be ventilated using Kearny pumps as illustrated in Figure B-48d.

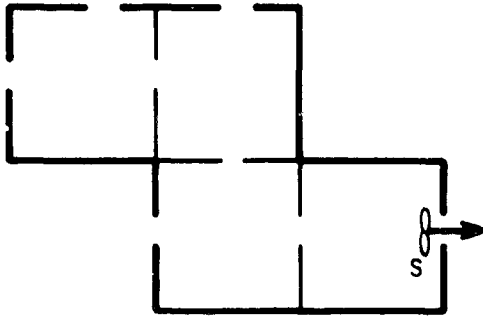

Fig. B-48a

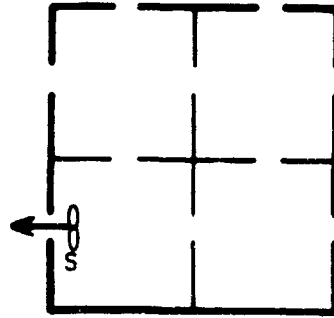

Fig. B-48b

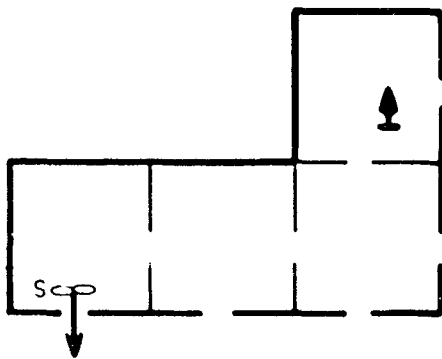

Fig. B-48c

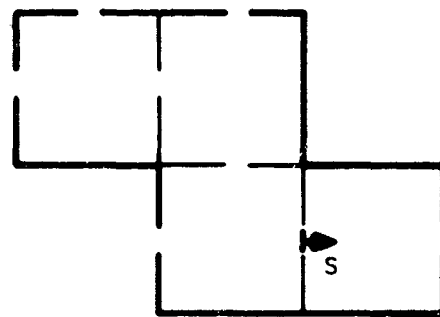

Fig. B-48d

Code

III-E-2

Partitioned into rooms of comparable size (four or more rooms not in series). Apertures not in all rooms.

A large number of possibilities exist under this classification. Several variations in the orientation of the rooms exist and for each orientation, several aperture configurations are possible. An attempt is not made to describe all of the possibilities but several specific examples are shown. Figure B-49a illustrates the procedure to be used if the side room is small enough to be ventilated with a Kearny pump. If the side room is not small enough to be ventilated with a Kearny pump, a PVK is used in this room and the duct passed through the apertures in the adjacent room as shown in Figure B-49b. Figure B-49c illustrates the use of Kearny pumps as supply devices for the configuration.

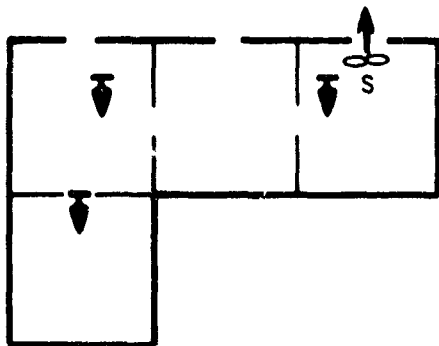

Fig. B-49a

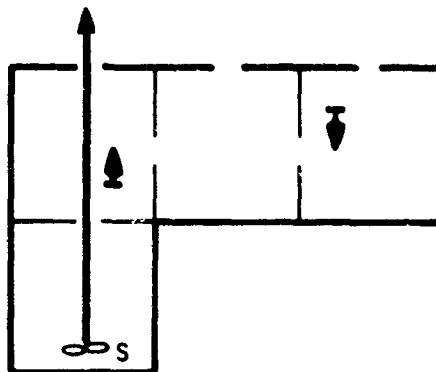

Fig. B-49b

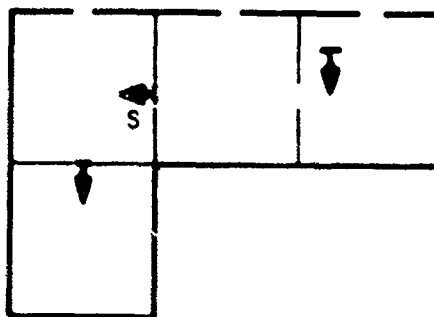

Fig. B-49c

Code

III-E-2
Cont'd.

In general, a PVK should be placed in one room so that air flows through as many rooms as possible. Kearny pumps may be used to ventilate rooms with no apertures which are adjacent to ventilated rooms, if these windowless rooms are sufficiently small. This is illustrated in Figures B-49d, B-49e, and B-49f. If the rooms are not sufficiently small, PVK's must be placed in these rooms and the ducts passed through the nearest apertures as shown in Figures B-49g and B-49h. PVK's may also be placed in windowless rooms which are not adjacent to a ventilated room as illustrated in Figure B-49h.

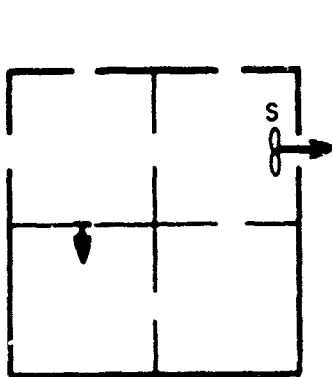

Fig. B-49d

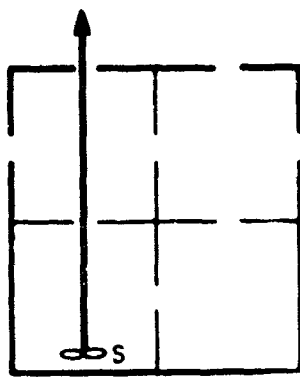

Fig. B-49e

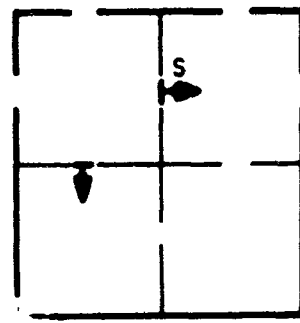

Fig B-49f

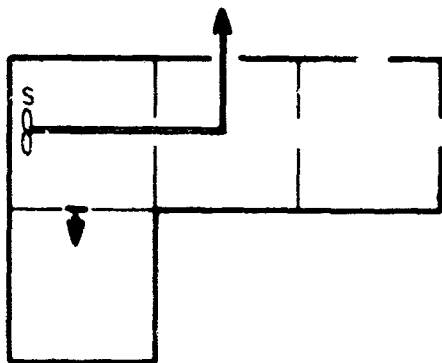

Fig. B-49g

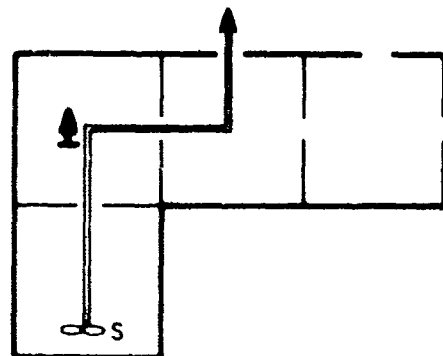

Fig. B-49h

All of these examples show four rooms but the procedures are applicable to any number of rooms.

Code

IV-A-1 Corridor with rooms off corridor. Apertures in the corridor and in all or part of the rooms.

PVK's are placed at the apertures in the corridor and fresh air enters through the apertures in the rooms. Kearny pumps may be used in the rooms if necessary for air distribution. Figures B-50a and B-50b show two possibilities using PVK's. Figure B-50c shows a method of ventilating this configuration using Kearny pumps to supply air. If apertures are present in only part of the rooms, the rooms with no apertures may be ventilated with Kearny pumps as illustrated in Figure B-50d.

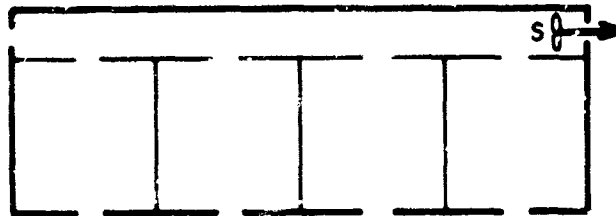

Fig. B-50a

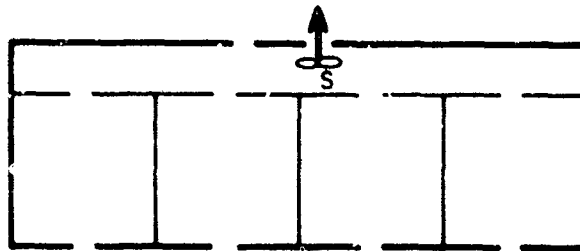

Fig. B-50b

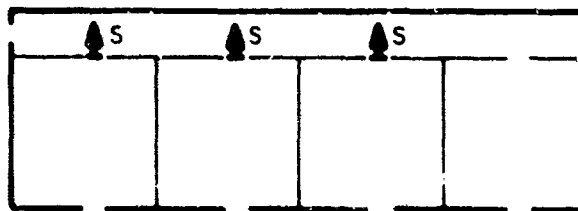

Fig. B-50c

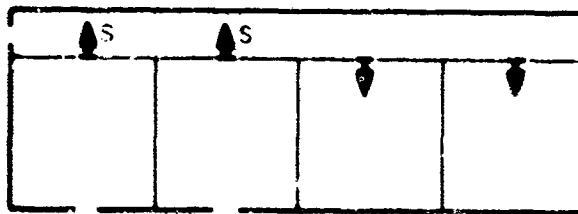

Fig. B-50d

Code

IV-A-2

Corridor with rooms off corridor. Apertures in all or part of rooms but not in corridor.

PVK's are placed in one or more rooms at one end of the corridor and fresh air enters through the other rooms and flows down the corridor (Figure B-51a). Kearny pumps are used for mixing the air in the rooms where necessary. Figure B-51b illustrates the use of Kearny pumps to supply air for the configuration. If apertures are present in only part of the small rooms, Figures B-51c and B-51d give possible means of ventilation.

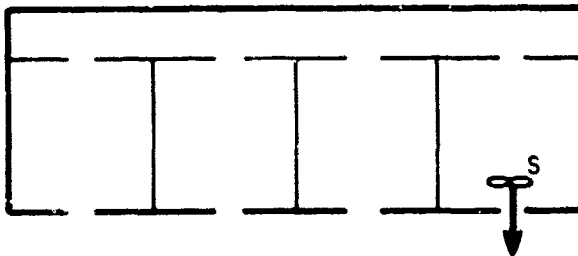

Fig. B-51a

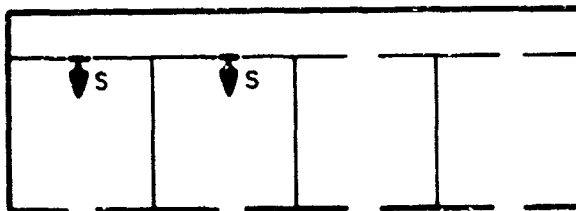

Fig. B-51b

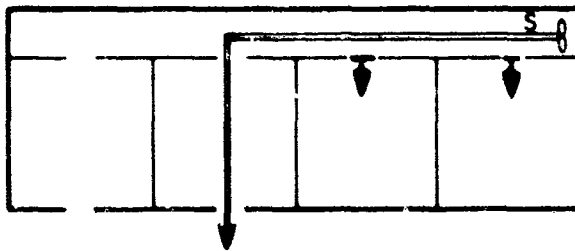

Fig. B-51c

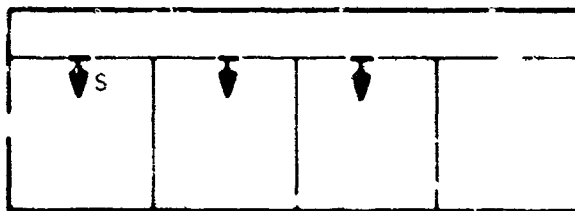

Fig. B-51d

Code

IV-A-3 Corridor with rooms off corridor. Apertures in corridor only.

If the corridor apertures are at or near each end of the corridor, a PVK is used at one end of the corridor and air allowed to enter at the other end (Figure B-52a). If the apertures are near the center of the corridor or occur in only one end of the corridor, PVK's are placed at the end or ends with no apertures and the duct passed along the corridor to the apertures (Figure B-52b). In both cases, Kearny pumps are used to supply air to the individual rooms. An example using a Kearny pump as a supply device is given in Figure B-52c. If the rooms are too large to be adequately ventilated with Kearny pumps, PVK's are placed in the rooms and the ducts passed through the corridor openings as shown in Figure B-52d.

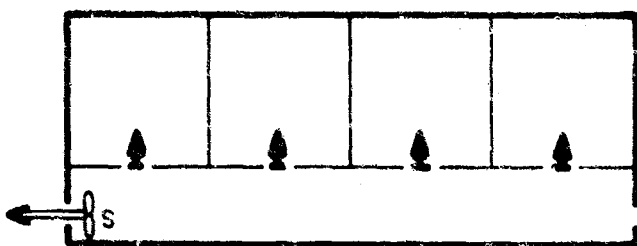

Fig. B-52a

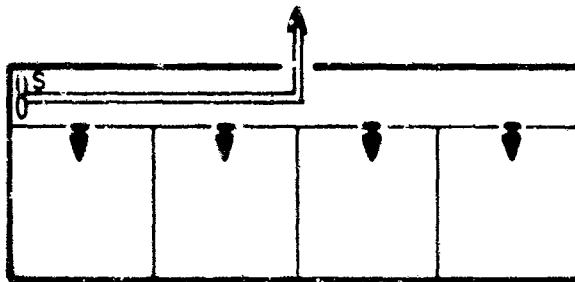

Fig. B-52b

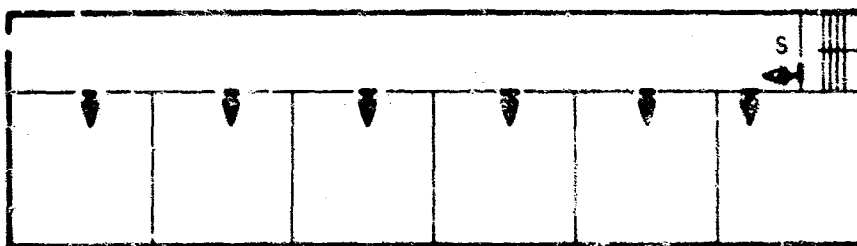

Fig. B-52c

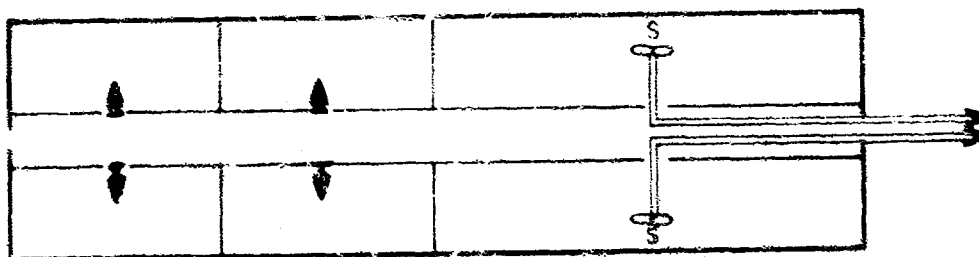

Fig. B-52d

Code

V-A-1

Corridor (with rooms off it) joining two large areas. Apertures in both large areas and in all small rooms.

PVK's are placed in one of the large areas and fresh air enters through each of the rooms and through the other large area (Figure B-53a). If required, PVK's could be placed in both large areas and air allowed to enter through the rooms (Figure B-53b). Kearny pumps may be used for mixing air, if necessary. Examples using Kearny pumps as a means of supplying air are given in Figures B-53c and B-53d.

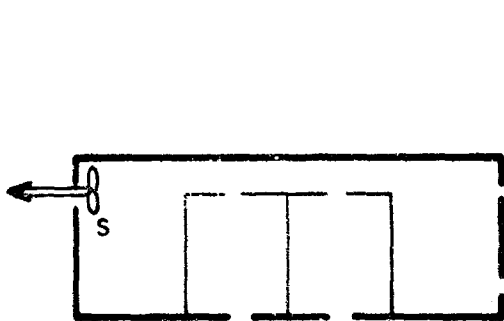

Fig. B-53a

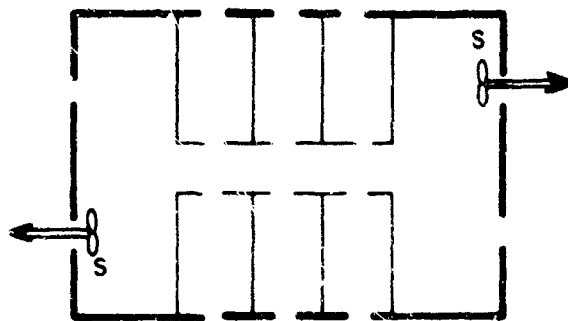

Fig. B-53b

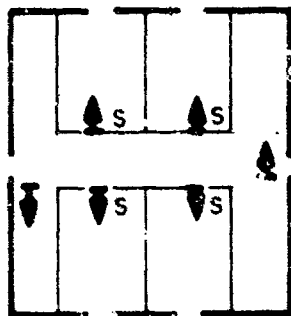

Fig. B-53c

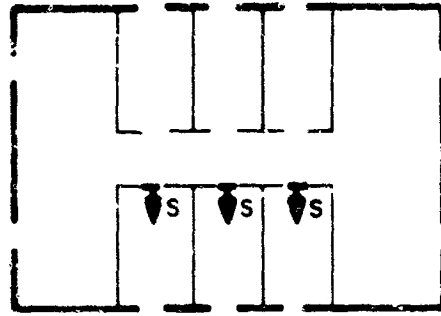

Fig. B-53d

Code

V-A-2

Corridor (with rooms off it) joining two large areas. Apertures in all small rooms but none in large areas or corridor.

PVK's are placed in each large area and the duct passed through the aperture in the nearest corridor room. Fresh air enters through the remaining corridor rooms. Kearny pumps are used to mix the air in the corridor rooms and/or large areas if necessary. An illustration is given in Figure B-54.

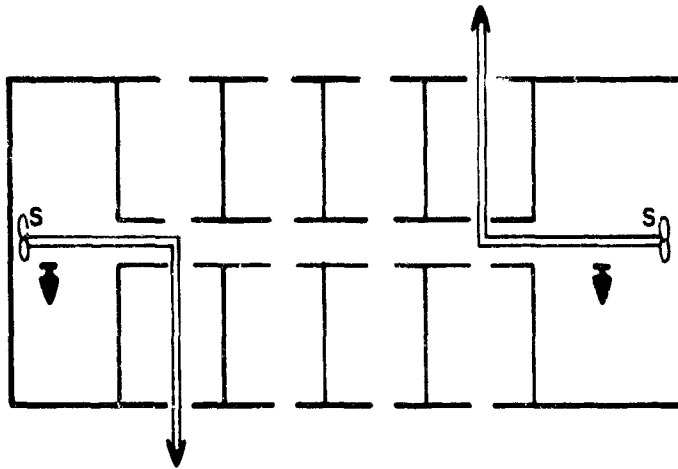

Fig. B-54

Code

V-A-3

Corridor (with rooms off it) joining two large areas. Apertures in some of the small rooms, but none in corridor and one or both of large areas.

PVK's are placed in the large areas and the ducts are passed through the apertures in the nearest corridor room. Fresh air enters through the apertures in the remaining corridor rooms. Kearny pumps are used to supply air to those rooms with no apertures. Kearny pumps are also used to mix air in small rooms and/or large areas, if necessary. An illustration is given in Figure B-55a. Figure B-55b illustrates the case with apertures in one large area.

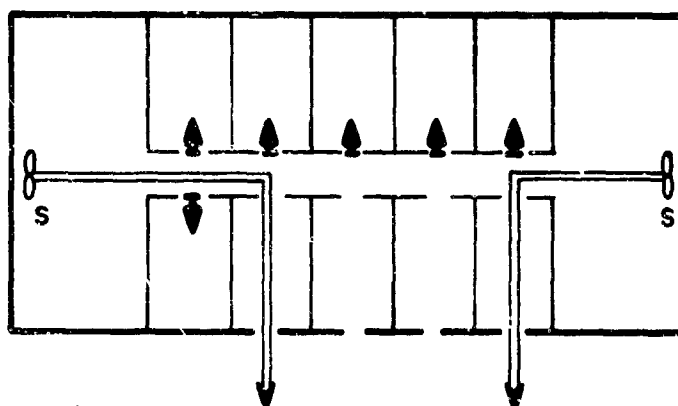

Fig. B-55a

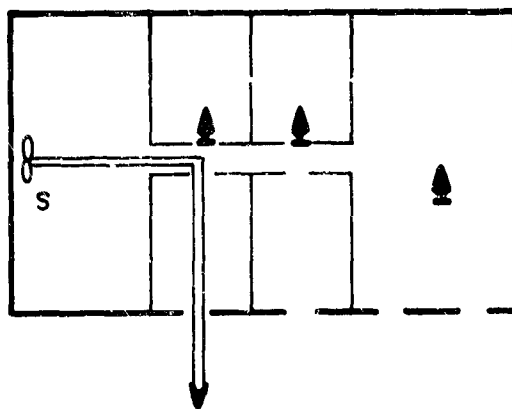

Fig. B-55b

Code

V-A-4

Corridor (with rooms off it) joining two large areas. Apertures in both large areas but none in corridor or small rooms.

PVK's are placed in one large area and fresh air enters through the other large area and passes down the corridor. Kearny pumps are used to supply air to the rooms off the corridor. Kearny pumps are also used to mix the air in the large areas, if necessary. Figure B-56 illustrates this configuration.

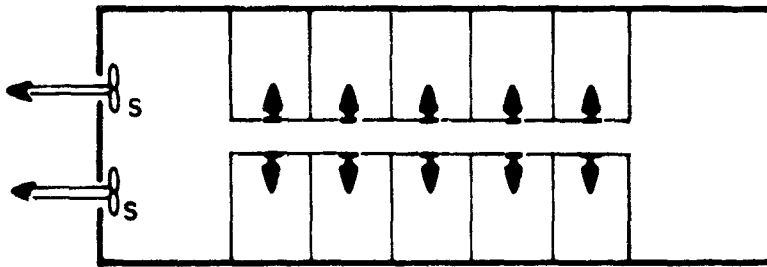

Fig. B-56

V-A-5

Corridor (with rooms off it) joining two large areas. Apertures in corridor but none in large areas or rooms off corridor.

Both large areas require PVK's and the ducts are passed out through the nearest corridor apertures. Fresh air enters through the remaining apertures. Kearny pumps are used to supply air to the rooms off the corridor as illustrated in Figure B-57.

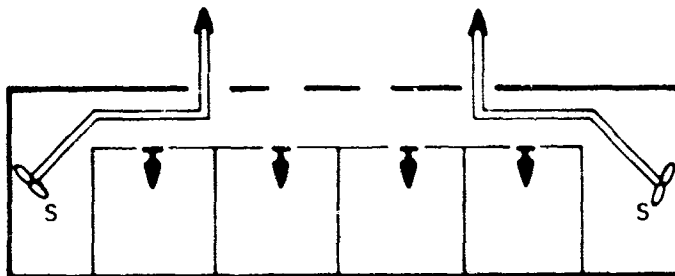

Fig. B-57

Code

V-A-6

Corridor (with rooms off it) joining two large areas. Apertures in one large area only.

The large area with no apertures requires a PVK and the duct is passed down the corridor and out through the apertures in the other large area. Fresh air enters through the remaining apertures. Kearny pumps are used to supply air to the rooms off the corridor as illustrated in Figure B-58.

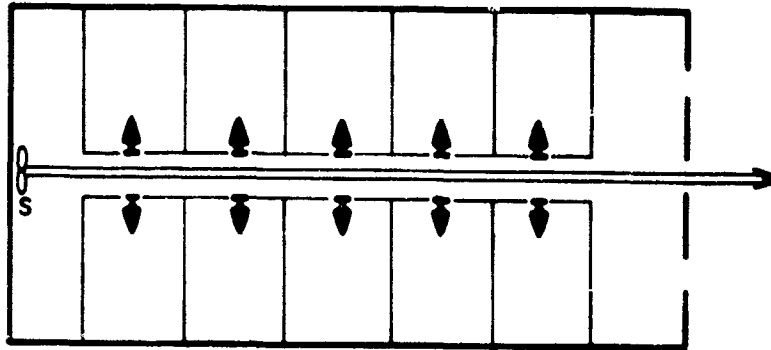

Fig. B-58

VI. REPORTING PROCEDURE

Figure B-59 shows a form which is to be filled out when a ventilation system is defined for a fallout shelter. The form is composed of three sections. These are: (1) Identification, (2) Configuration Code, and (3) Ventilators Required sections. The Ventilators Required section is subdivided into "Kearny pumps" and "PVK's."

Following is a description of the entries to be made on the form:

A. Identification

- 1) Name/Address: The name and address of the facility is entered as it appears on the SAF form.
- 2) Standard Location: The Standard Location of the facility is entered in these columns.
- 3) Facility Number: The facility number of the shelter is entered in these columns.

B. Story

The story number on which the shelter area to be ventilated occurs is entered.

C. Configuration Code

The code selected in paragraph IV.B., which identifies the shelter and aperture configuration is entered.

D. Ventilators Required

1. Kearny Pumps

After the ventilation system has been defined for the shelter, the total number of Kearny pumps selected for deployment is entered in the column under "Kearny pumps."

2. Fans

After the ventilation system has been defined, the total number of PVK ventilators required is entered in the column under "PVK's."

A. Identification					
1. Name/Address		2. Standard Location		3. Facility Number	
B. Story	C. Configuration Code		D. Ventilators Required		
			1. Kearney Pumps		2. PVK's
			Type I	Type II	

Figure B-59 Sample Data Form

REFERENCES

- B-1 Department of the Army. National Fallout Shelter Survey Program PVK Survey Instructions. ER 1190-1-2, Washington, D. C.: Office of the Chief of Engineers, 1967.
- B-2 Kearny, Cresson H., Manual Shelter-Ventilating Devices for Crowded Shelters Cooled by Outside Air--A Preliminary Report. Oak Ridge, Tennessee: U.S. Atomic Energy Commission, Oak Ridge National Laboratory, June 8, 1965. ORNL-TM-1154, Copy No. 52.
- B-3 Svaeri, O. W. and N. I. Stein, Air Distribution Studies in Multi-Room Shelters, Final Report. Washington, D. C.: Office of the Chief of Engineers, Department of the Army, March 1967. PSDC TR-21/22.

APPENDIX C
Examples of Methodology Application

Appendix C

Examples of Methodology Application

I. INTRODUCTION

This appendix contains examples of the ventilation plans defined for four of the buildings in the 62-building sample described in Section III. B. In three of these buildings, a significant change is evidenced between the results of the Desk Survey and the results of the Field Survey. Both of these ventilation plans are shown for these three buildings. The fourth example does not show any change between the Desk Survey and the Field Survey. Building numbers refer to buildings as previously identified in Table II and cross-hatched areas on the sketches indicate areas that are not usable as shelter area.

II. EXAMPLES

A. Building Number 40

Figure C-1 shows the example building as it appeared on the NFSS-PVK Survey Form. The ventilation system defined in the Desk Survey consists of 2 PVK's and 1 Type I Kearny pump deployed according to the instructions for a configuration code I-B-2d (see Appendix B). Apertures were reported on side A in both Phase 1 and Phase 2 of the NFSS. The ventilation plan shown resulted in 138 additional spaces at a cost per space added of \$2.01. The PVK Survey also yielded 138 spaces added but the cost per space added was \$3.45.

Figure C-2 shows the same facility and includes additional apertures found during the Field Survey. The additional apertures permitted a ventilation plan to be defined in the Field Survey using only a single Type II Kearny pump. This ventilation plan also resulted in 138 spaces added; however, the cost per space added was reduced to \$0.64.

B. Building Number 45

Figure C-3 shows the floor plan of Building Number 45 as it was shown on the NFSS-PVK Survey Form and as used in the Desk Survey. This figure indicates only one opening into the shelter at one end of the corridor, and no apertures were reported in the NFSS Phase 1 or Phase 2 data. The ventilation plan defined in the Desk Survey for this shelter consists of 4 PVK ventilators and 6 Type I Kearny pumps. The equipment deployment shown in Figure C-3 was defined following the

instructions given in the methodology for a shelter configuration code IV-A-3 (see Appendix B). A total of 227 shelter spaces were added at a cost of \$3.00 per space added using this ventilation plan, compared to 327 spaces added in the original NFSS-PVK Survey at a cost of \$3.59 per space added.

Figure C-4 shows the floor plan for the same facility including the additional apertures found during the field visit. This figure also shows the revised ventilation plan defined for the facility in the Field Survey. The presence of the additional apertures permitted an adequate ventilation plan to be defined using 3 PVK's instead of the 4 required in the Desk Survey. Three ventilators are sufficient because they can be used with zero duct lengths and therefore are capable of delivering as much air as 4 PVK's in the previous configuration. The Kearny pumps used in the Desk Survey (Figure C-3) are not necessary since the aperture distribution provides adequate distribution of air throughout the shelter. The number of spaces added in the Field Survey was 407 and the cost per space added decreased to \$0.89.

C. Building Number 55

Figure C-5 shows Building Number 55 as it appears on the NFSS-PVK Survey Form and as used in the Desk Survey. The only opening indicated is the single stairway. The ventilation plan shown consists of 2 PVK's deployed according to the instructions for a shelter configuration code I-A-5 (see Appendix B). No apertures were reported in NFSS Phase 1, however, an aperture sill height was indicated in NFSS Phase 2 for building sides C and D. The NFSS-PVK Survey indicated 180 spaces added at a cost per space added of \$2.43.

Figure C-6 shows the same facility with two additional apertures noted during the field visit. Utilizing these apertures, a ventilation plan was defined in the Field Survey with only 1 PVK because of the shorter duct length permitted and the consequent greater PVK efficiency. Although the spaces added in both the Desk Survey and the Field Survey were the same as in the NFSS-PVK, the respective costs per space added were \$1.32 and \$0.86.

D. Building Number 19

Figure C-7 shows Building Number 19 in which there was no change between the Desk Survey and the Field Survey. This facility consists of two rooms which are not interconnected and each of the rooms was ventilated independently according to the instructions for a shelter configuration code I-A-5 in Appendix B. One used a single PVK and the other used a single Type I Kearny pump. The ventilation plan provided for 120 spaces added at a cost per space added of \$1.44 in the Desk Survey and \$1.60 in the Field Survey. This is compared to a cost per space added of \$3.15 in the PVK Survey which also reported 120 spaces added.

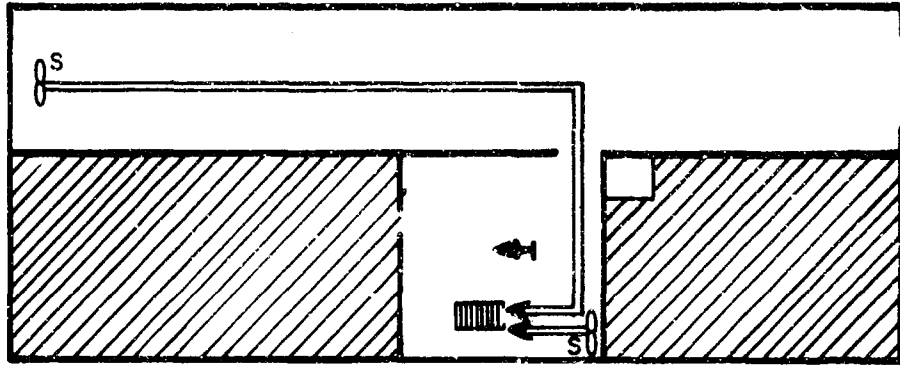

Fig. C.1. Building Number 40;
Ventilation Plan from Desk Survey.

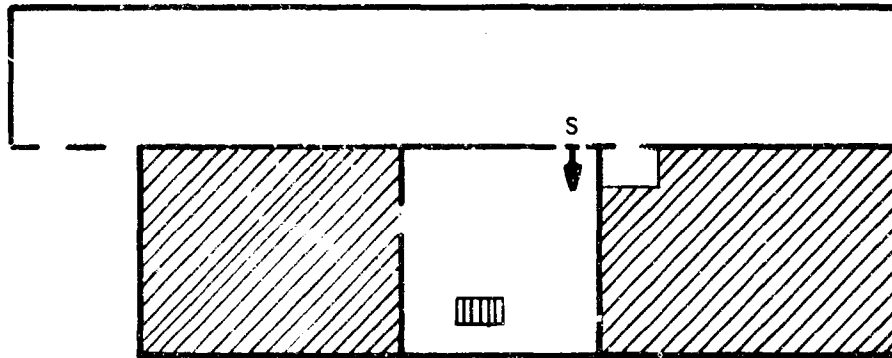

Fig. C.2. Building Number 40;
Ventilation Plan from Field Survey.

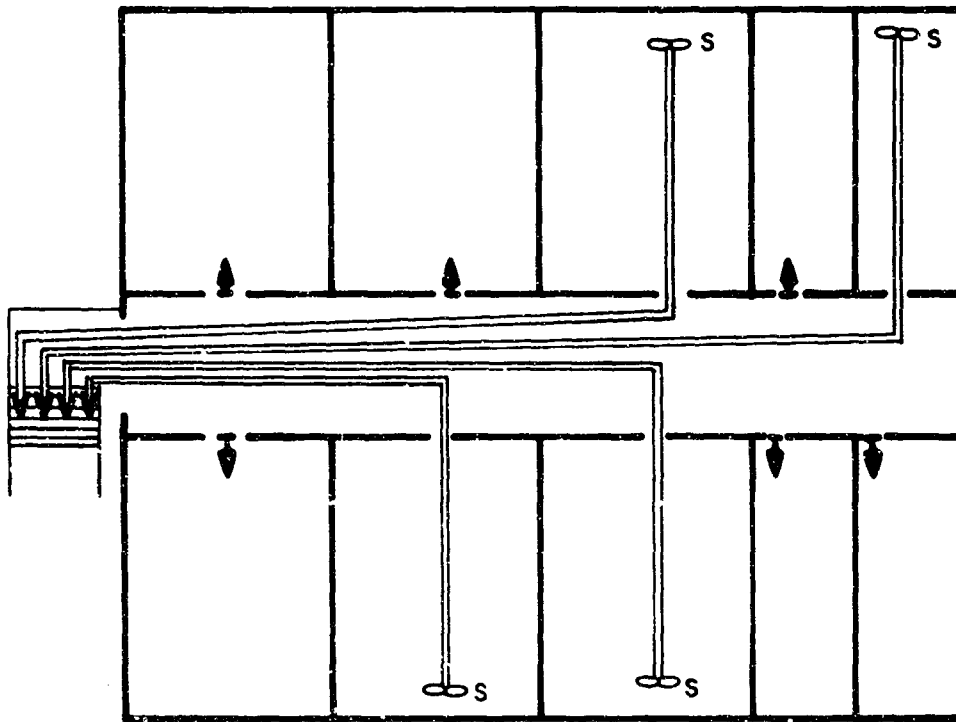

Fig. C.3. Building Number 45;
Ventilation Plan from Desk Survey.

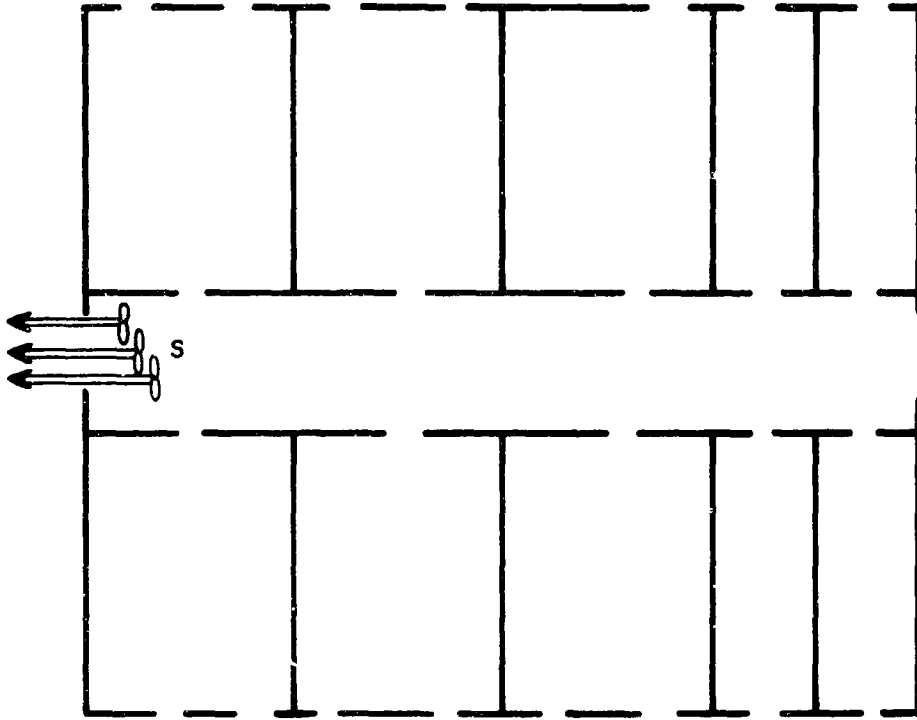

Fig. C.4. Building Number 45;
Ventilation Plan from Field Survey.

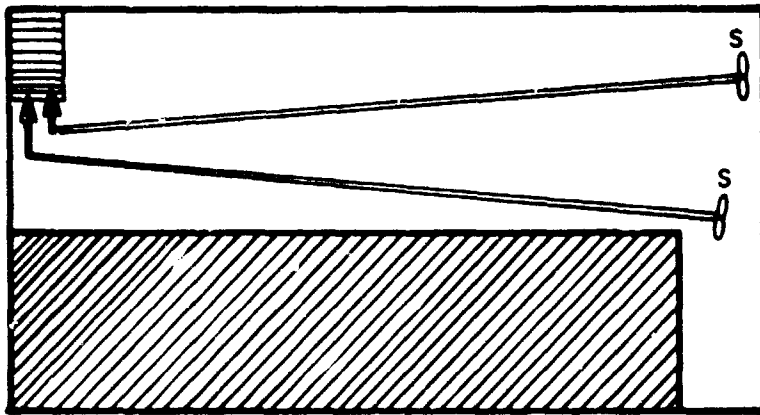

Fig. C.5. Building Number 55;
Ventilation Plan from Desk Survey.

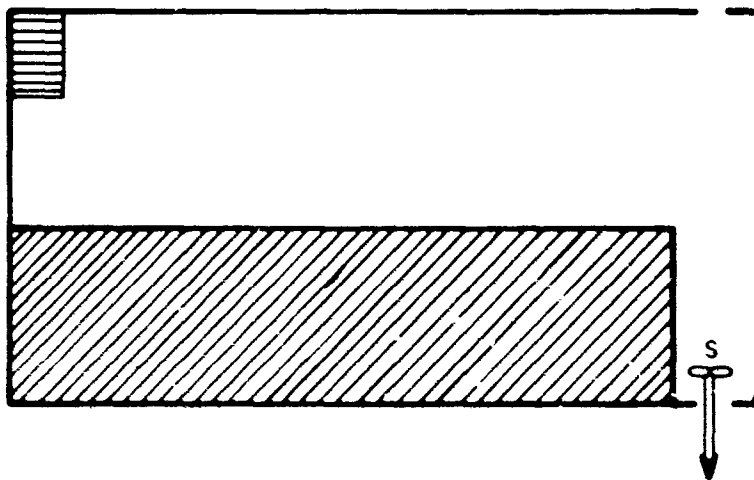

Fig. C.6. Building Number 55;
Ventilation Plan from Field Survey.

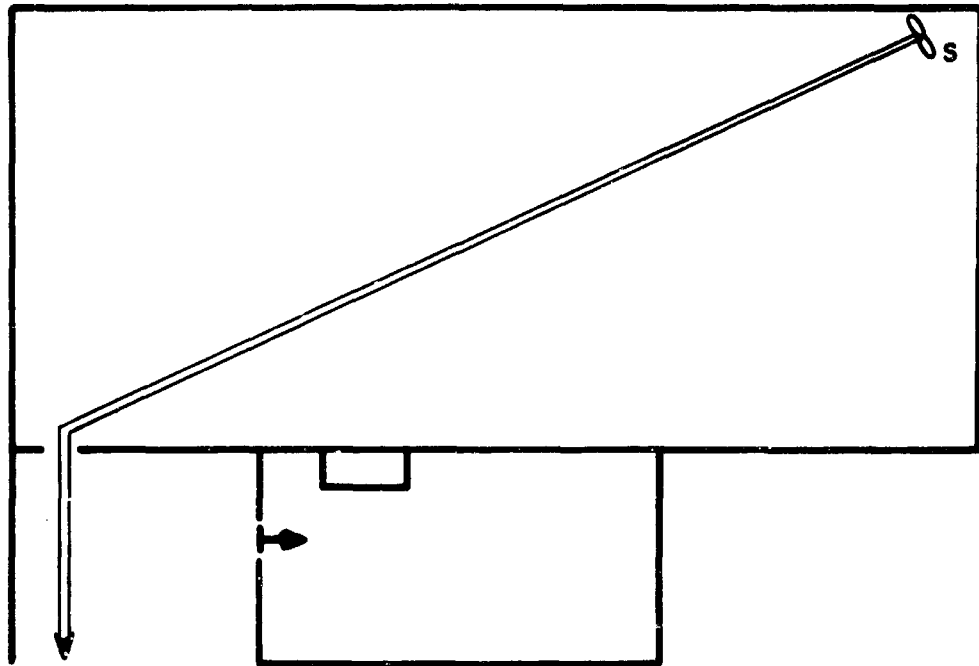

Fig. C.7. Building Number 19;
Ventilation Plan from Desk Survey and Field Survey.

UNCLASSIFIED

Security Classification

DOCUMENT CONTROL DATA - R & D

(Security classification of title, body of abstract and indexing annotation must be entered when the overall report is classified)

1. ORIGINATING ACTIVITY (Corporate author) Research Triangle Institute Research Triangle Park, North Carolina 27709		2a. REPORT SECURITY CLASSIFICATION Unclassified	
		2b. GROUP Not applicable	
3. REPORT TITLE Ventilation Kit Application Study			
4. DESCRIPTIVE NOTES (Type of report and inclusive dates) Final Report June, 1968 - February, 1970			
5. AUTHOR(S) (First name, middle initial, last name) Milton D. Wright, Edward L. Hill, and Carl T. Sawyer			
6. REPORT DATE February, 1970	7a. TOTAL NO. OF PAGES 106	7b. NO. OF REFS 12	
8a. CONTRACT OR GRANT NO. DAHC20-68-C-0166	9a. ORIGINATOR'S REPORT NUMBER(S) R-OU-400		
b. PROJECT NO. c. Work Unit 1233B	9b. OTHER REPORT NO(S) (Any other numbers that may be assigned this report) None		
10. DISTRIBUTION STATEMENT This document has been approved for public release and sale; its distribution is unlimited.			
11. SUPPLEMENTARY NOTES		12. SPONSORING MILITARY ACTIVITY Office of Civil Defense Office of the Secretary of the Army Washington, D. C. 20310	
13. ABSTRACT This report describes the development and field testing of a methodology for allocating and deploying emergency ventilation equipment to fallout shelters. The methodology developed is based on six basic shelter configurations into which NFSS structures which require additional ventilation may be categorized. Development of the methodology consisted of using NFSS data for buildings and defining a standard set of ventilation equipment deployment plans for each combination of shelter and aperture configuration. The ventilation equipment considered in this methodology included a 30-inch manually-powered PVK, a 36-inch Kearny pump, and a 72-inch Kearny pump. The methodology was tested by applying it to two sets of real buildings, one set of which had previously been surveyed in the NFSS-PVK Survey and another set which had not. The methodology was first used to define ventilation plans for each of the buildings using only the available NFSS data. Each building was then visited and the ventilation plans were modified on the basis of additional data obtained during the visit. A ventilation plan was also defined for each building solely on the basis of the usable area which each shelter contained. The result of the test applications of the methodology was an increase of about 10 percent in spaces added when compared to the NFSS-PVK Survey. The cost per space added including survey costs, was \$1.34 using NFSS data only, \$1.19 using NFSS data and including a field visit, and \$1.54 using the usable area in each facility as the allocation criterion and assuming zero survey costs. The cost per space added for equipment alone in the NFSS-PVK Survey was \$2.52.			

DD FORM 1473 NOV 68

REPLACES DD FORM 1473, 1 JAN 63, WHICH IS OBSOLETE FOR ARMY USE.

UNCLASSIFIED

Security Classification

14. KEY WORDS	LINK A		LINK B		LINK C	
	ROLE	WT	ROLE	WT	ROLE	WT
Civil Defense Systems Fallout Shelters National Fallout Shelter Survey Shelter Improvement Ventilation Ventilation Equipment						