

AD706226

AD

Report 1974

UNIVERSAL FOLDED PLATE (UFP) STRUCTURAL SYSTEM

by

Edward J. Schultze and Lloyd E. Krivanek

January 1970

This document has been approved for public
release and sale; its distribution is unlimited.



**U. S. ARMY MOBILITY EQUIPMENT RESEARCH AND DEVELOPMENT CENTER
FORT BELVOIR, VIRGINIA**

Reproduced by the
CLEARINGHOUSE
for Federal Scientific & Technical
Information, Springfield, Va. 22151



120

DISCLAIMER NOTICE

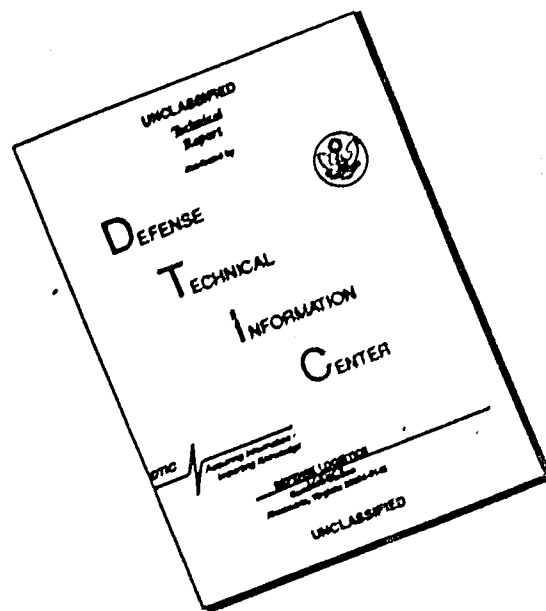

THIS DOCUMENT IS BEST QUALITY AVAILABLE. THE COPY FURNISHED TO DTIC CONTAINED A SIGNIFICANT NUMBER OF PAGES WHICH DO NOT REPRODUCE LEGIBLY.

ACCESSION FOR	
CP&I	WHITE SECTION <input checked="" type="checkbox"/>
DDC	DIFF SECTION <input type="checkbox"/>
UNANNOUNCED	<input type="checkbox"/>
JUSTIFICATION	
BY	
DISTRIBUTION/AVAILABILITY CODES	
DIST.	AVAIL. and/or SPECIAL
1	

Destroy this report when no longer needed.
Do not return it to the originator.

The findings in this report are not to be construed as an official
Department of the Army position unless so designated by other
authorized documents.

**U. S. ARMY MOBILITY EQUIPMENT
RESEARCH AND DEVELOPMENT CENTER
FORT BELVOIR, VIRGINIA**

Report 1974

UNIVERSAL FOLDED PLATE (UFP) STRUCTURAL SYSTEM

Task 1J662708D55007

January 1970

Distributed by

**The Commanding Officer
U. S. Army Mobility Equipment Research and Development Center**

Prepared by

**Edward J. Schultze and Lloyd E. Krivanek
Marine and Bridge Division
Military Technology Laboratory**

**This document has been approved for public
release and sale; its distribution is unlimited.**

SUMMARY

This report covers the limited engineer design tests and evaluation of the Universal Folded Plate (UFP) Structural System. The UFP structural system is comprised of full-size, folded, diamond-shaped panels; longitudinal half panels; and transverse half panels which can be fastened together to construct shelters of various shapes and sizes.

Two different structures were erected and structurally tested. One was an arch-type structure 52 ft wide, 40 ft long, and 38 ft high; the other was a flat-roof structure 54 ft wide, 25 ft long, and 15 ft high.

The design loads for the two structures (arch-type and flat-roof) were as follows:

- a. Dead load = 16 psf.
- b. Live loads:
 - (1) Snow load = 25 psf.
 - (2) Wind load = 30 psf at 30-ft height (for wind = 100 mph).
- c. Factor of safety = 1.25.

Several test beams were constructed. The test beams were of two configurations, straight and curved. Static load was applied to each of the test beams until structural failure occurred.

The report concludes:

- a. Structural integrity can be maintained for various shapes and sizes of shelters within the limits of the building configurations tested. Structural testing of the two buildings showed no stresses in excess of accepted allowables.
- b. Watertightness, as achieved by the designed sealant gasket and by the method of caulking as performed after erection of the flat-roof building, was not satisfactory.
- c. A number of various building configurations can be constructed using the single UFP component structural system since the panels are reusable, interchangeable, and reversible.

d. No special foundation or foundation preparation is necessary in areas where the soil is capable of withstanding the weight of the building plus design loads. Where the ground is to be the foundation, only a smooth surface is required.

e. The UFP structural system appears to be readily adaptable to hardened shelter concepts for use by the military.

f. Additional test and evaluation is necessary to determine full military potential. A cost-effectiveness study should be included in the total evaluation.

FOREWORD

This project was initiated in August 1968 when Task 1J662708D55007 was established and funded to procure, investigate, and evaluate the UFP structural system.

The project was conducted by the Marine and Bridge Division, Military Technology Laboratory, U. S. Army Mobility Equipment Research and Development Center (USAMERDC), Fort Belvoir, Virginia, from August 1968 through June 1969.

The following personnel were directly involved in this project:

Edward J. Schultze, Project Engineer.

Lloyd E. Krivanek, Civil Engineer.

James M. Winkler, Engineer Technician.

George A. Hinkle, Physical Science Technician.

James R. Hess, Bridge Equipment Test Operator.

CONTENTS

Section	Title	Page
	SUMMARY	ii
	FORWORD	iv
	ILLUSTRATIONS	vi
	TABLES	x
I	INTRODUCTION	
	1. Subject	1
	2. Background	1
	3. Description of UFP System	1
II	INVESTIGATION	
	4. Structural Configurations	4
	5. Erection Procedures	4
	6. Test Procedures	35
	7. Test Results	59
III	DISCUSSION	
	8. Analysis of Test Results	87
	9. Nonstructural Evaluations	93
	10. Related Evaluations	100
IV	CONCLUSIONS	
	11. Conclusions	101
	APPENDIX – Universal Folded Plate (UFP) Shell Structures – Plan of Test for FS/EDT	103

ILLUSTRATIONS

Figure	Title	Page
1	UFP Structures	2
2	UFP Panels	3
3	Transverse Stiffeners	3
4	UFP Component Unit, 8 Ft Long, Single-Skin Type, 10-Gage Steel	5
5	Transverse Stiffener, Six-Hole	6
6	Arch-Type Building Configuration	7
7	Flat-Roof Building Configuration	8
8	UFP Straight Test Beam	9
9	UFP Curved Test Beam	10
10	Handtools	11
11	Arch-Type Building Configuration – Order of Panel Installation	13
12	Method of Panel Assembly	14
13	Panel Assembly Continuation	14
14	Transverse Stiffener Installation	15
15	Structure Erection	16
16	Structure Erection – Cable Sling Adjustment	16
17	Structure Erection – 30 Percent Complete	17
18	Cable Sling Adjustment at 30-Percent Completion	17
19	Crane Lift of Structure at 30-Percent Completion	18
20	Crane Lift of Structure at 60-Percent Completion	18
21	Structure Erection – 60 Percent Complete	19

ILLUSTRATIONS (cont'd)

Figure	Title	Page
22	Structure 70 Percent Complete – Jack-Supported	19
23	Structure Erection – 70 Percent Complete	20
24	Structure Erection – 85 Percent Complete	20
25	Structure 85 Percent Complete – End View	21
26	Structure Complete – Sidewall Not Positioned	21
27	End View – Sidewalls Not Positioned	22
28	Complete Structure	22
29	Foundation Anchor Installation	23
30	Flat-Roof Building Configuration – Order of Panel Installation	25
31	Flat Roof – 50 Percent Complete	26
32	Roof Supports – 50 Percent Complete	26
33	Flat Roof Complete – Sidewall 40 Percent Complete	27
34	Sidewall-Roof Complete – Preparation for Crane Lift to Join Second Sidewall	27
35	Flat Roof and Sidewall Completed	28
36	Sidewall and Flat Roof Prior to Mating	29
37	Preparation for Crane Lift of Roof-Wall Combination	29
38	Flat Roof Raised to Position for Building Completion	30
39	Flat Roof Raised – Preparation to Position Sidewall	30
40	Roof and Sidewall Prior to Mating	31
41	Roof-Sidewall Set Together Prior to Bolt Installation	32
42	Installation of Bolts for Joining of Roof to Sidewall	32

ILLUSTRATIONS (cont'd)

Figure	Title	Page
43	Complete Structure	33
44	Caulking Application	34
45	Caulked Joints	34
46	Six-Hole Transverse Stiffener Installation	35
47	Strain Gage Locations – Arch-Type Building Configuration	38-41
48	Strain Gage Wiring	42
49	Strain Gage Wire Harness	42
50	Stadia Rod Installation	43
51	Arch-Type Building Configuration – Test Load Application Area	44
52	Method of Raising Sand and Men to Roof	45
53	Sandbag Placement	45
54	Movement of Pallet for Sandbag Placement	46
55	Equipment Carrying Men to Rooftop	47
56	Test Load Application	47
57	Aircraft Engine Location for Wind Test	49
58	Wind Test Equipment Arrangement	50
59	Wind Test Load Application	51
60	Strain Gage Locations – Flat-Roof Building Configuration	52-54
61	Flat-Roof Building Configuration – Test Load Application Area	55
62	Storm Effects on Loaded Roof	57
63	Storm Effects on Roof Cover	57

ILLUSTRATIONS (cont'd)

Figure	Title	Page
64	Wind Test Equipment Setup -- Side View	58
65	Wind Test Equipment Setup -- End View	58
66	Flat-Roof Building Configuration Post Tension Setup	60
67	Straight Beam Test Setup	61
68	Curved Beam (Without Stiffeners) Test Setup	62
69	Curved Beam (With Stiffeners) Test Setup	62
70	Straight Test Beam With Angle Transverse Stiffeners	82
71	Load Versus Deflection Curve for Straight Test Beam With Angle Transverse Stiffeners	83
72	Straight Test Beam With Six-Hole Transverse Stiffeners	84
73	Failure Adjacent to Nodal Point on Load Side of Beam	85
74	Nodal Point Failure on Side Opposite Load	85
75	Load Versus Deflection Curves for Straight Test Beam With Six-Hole Stiffeners	86
76	Curved Test Beam Without Transverse Stiffeners	88
77	Load Versus Deflection Curves for Curved Test Beam Without Stiffeners	89
78	Curved Test Beam With Angle Transverse Stiffeners	90
79	Load Versus Deflection Curves for Curved Test Beam With Stiffeners	91
80	Gasket Sealing Capability Test	92
81	Flange Weld Failure at Obtuse Angle of Panel	94
82	Crack in Parent Material Along Panel Fold Line Propagating From Obtuse Angle End of Panel	94
83	Failure At and Adjacent to Nodal Point	95

ILLUSTRATIONS (cont'd)

Figure	Title	Page
84	Manufacturing Tolerance Check – Panel 1	97
85	Manufacturing Tolerance Check – Panel 2	98
86	Truckload of UFP Components	99
87	Palletized UFP	99

TABLES

Table	Title	Page
I	Simulated Snow Load Stresses – Arch-Type Structure	64-65
II	Simulated Snow Load Deflections – Arch-Type Structure	66
III	Simulated Wind Load Stresses – Arch-Type Structure	67-68
IV	Simulated Wind Load Deflections – Arch-Type Structure	69
V	Simulated Combined Load Stresses – Arch-Type Structure	70-71
VI	Simulated Combined Load Deflections – Arch-Type Structure	72
VII	Simulated Snow Load Stresses – Flat-Roof Structure	73-74
VIII	Simulated Snow Load Deflections – Flat-Roof Structure	75
IX	Simulated Wind Load Stresses – Flat-Roof Structure	76-77
X	Simulated Wind Load Deflections – Flat-Roof Structure	78
XI	Simulated Combined Load Stresses – Flat-Roof Structure	79
XII	Simulated Combined Load Deflections – Flat-Roof Structure	80

UNIVERSAL FOLDED PLATE (UFP) STRUCTURAL SYSTEM

I. INTRODUCTION

1. **Subject.** This report covers the limited engineer design tests and evaluation of the UFP structural system.

2. **Background.** The UFP structural system is the invention of Mr. Arpad Kolozsvary. Patent applications have been filed by Mr. Kolozsvary in connection with the UFP structural system. Two unsolicited disclosures on the UFP structural system were sent to two different government agencies in March 1968 and were subsequently forwarded to USAMERDC for evaluation. A briefing on the UFP concept was held at USAMERDC on 9 July 1968 with representatives of the Office, Assistant Secretary of Defense (OASD); U. S. Air Force; U. S. Army Mobility Command (USAMC); U. S. Army Combat Developments Command; Office, Chief of Engineers; and Natick Laboratories in attendance.

On 1 August 1968, USAMC established and funded Task 1J662708D55007, "Prefabricated Shell Building Systems," for the purposes of procurement, investigation, and evaluation of the UFP structural system. A USAMC directive, dated 5 August 1968, requested that an expedited development program be initiated covering full-scale feasibility and engineering tests and that a demonstration/briefing be held at USAMERDC for representatives of OSD and other Government agencies. Two demonstration/briefings were presented at USAMERDC on 20 and 21 November 1968. Three different shaped structures constructed of 10-gage steel, 18-gage steel, and reinforced plastic panels were constructed for the briefing and are shown in Fig. 1. An interim letter report was prepared in January 1969 covering this preliminary evaluation of the UFP structural system. In November 1968, a contract was awarded for a larger quantity of 10-gage galvanized steel UFP for the structural tests and evaluation covered in this report.

In January 1969, a release and license agreement was negotiated between Mr. Kolozsvary and the Department of Defense for manufacturing rights of the UFP structural system.

3. **Description of UFP System.** This system is comprised of folded diamond component units. They are of a single type, identical and interchangeable, and consist of full-size panels, longitudinal half panels, and transverse half panels (Fig. 2) which can be fastened together into structures. The system is unique in that a wide variety of different shapes and sizes of structures can be constructed from the same set of components. Each folded diamond panel has a convex and a concave side. The panels can be connected to each other in reversed as well as in identical relative fold positions which

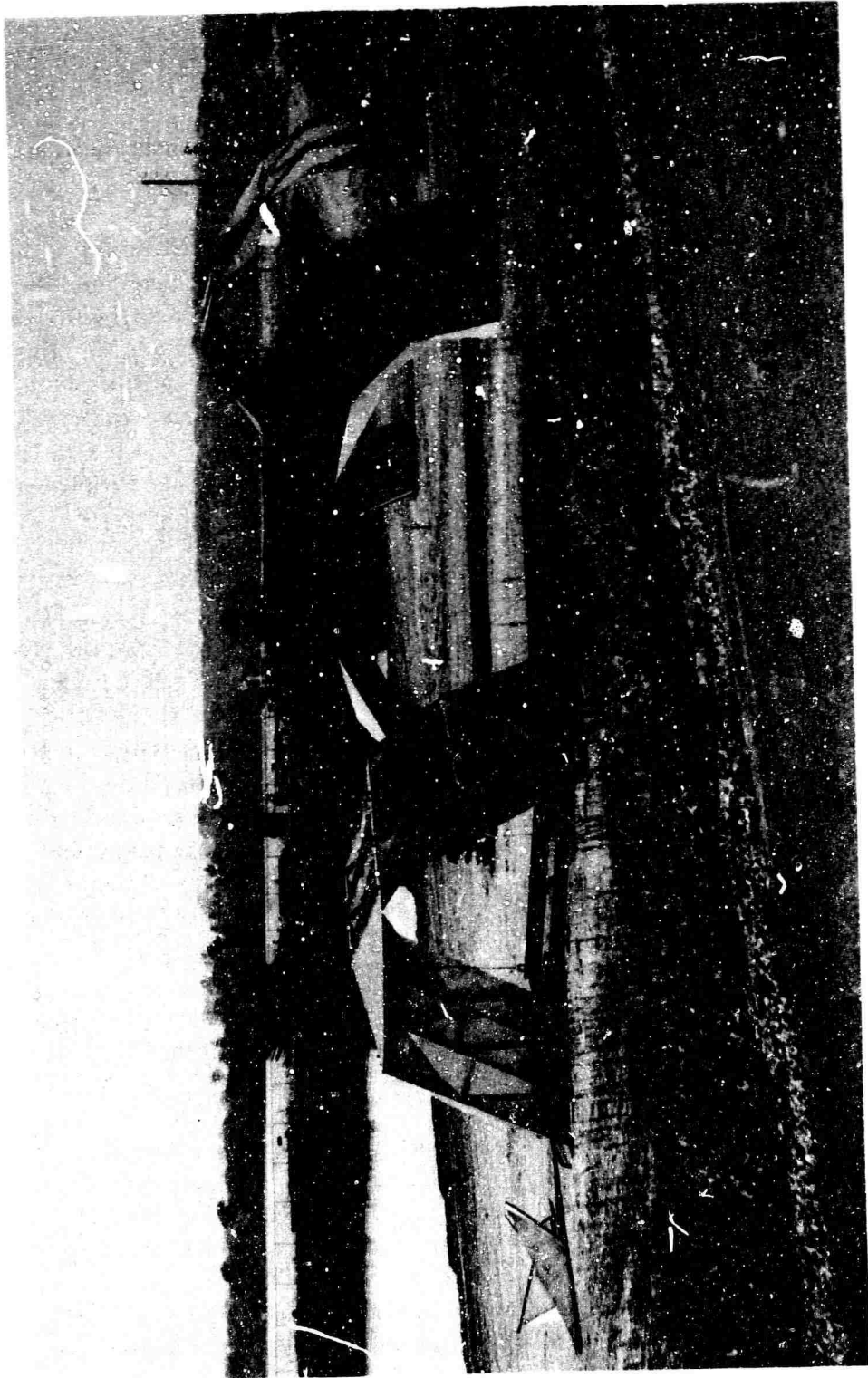

R9759

Fig. 1. UFP structures.



Fig. 2. UFP panels.

S6850



Fig. 3. Transverse stiffeners.

S6844

permits straight or curved sections to be constructed from the same components. The panels which are interchangeable and reusable can be standardized for mass production for various types and sizes of structures without having to standardize the individual shelter. Transverse stiffeners can be used to increase the structural capability of a structure constructed of UFP. The transverse stiffeners are attached at the obtuse corners of the panels to stop the panels from opening or closing when subjected to loads. Three types of stiffeners were designed and are shown in Fig. 3. The panels are bolt-connected, and a waterseal between the panels is provided by compressible elastomeric gaskets which are adhesive-bonded around the periphery of the panels. A detail drawing of the 8-foot-long panel is shown in Fig. 4. The latest design of the transverse stiffener is shown in Fig. 5. The shape of the UFP components allows them to be nested during transportability, thereby providing a high degree of mobility due to minimum storage and shipping cubage.

II. INVESTIGATION

4. **Structural Configurations.** Two different structures were erected and tested in conjunction with the overall UFP evaluation. In addition to the two test structures, several test beams were constructed of UFP to assist in the evaluation. The various configurations are as follows:

a. **Arch-Type.** This is a configuration with possible usage as an expandable aviation maintenance hangar (Fig. 6).

b. **Flat-Roof.** This is a configuration with possible usage as a warehouse or other similar use (Fig. 7).

c. **Test Beams.** These configurations are as shown in Fig. 8 and Fig. 9. The purpose of the test beams was:

(1) An aid in the determination of erection methods and procedures to be used during erection of the arch-type and flat-roof structural configurations.

(2) An aid in determining the critical stress areas of the arch-type and flat-roof structural configurations for test purposes.

5. **Erection Procedures.** Erection of a UFP structure consists of bolting the UFP panels together to form the desired configuration. The UFP panels are bolt-connected to each other through their overlapping flanges. The following erection procedures were accomplished using the listed erection aids during the construction of the arch-type and flat-roof structures and test beams.

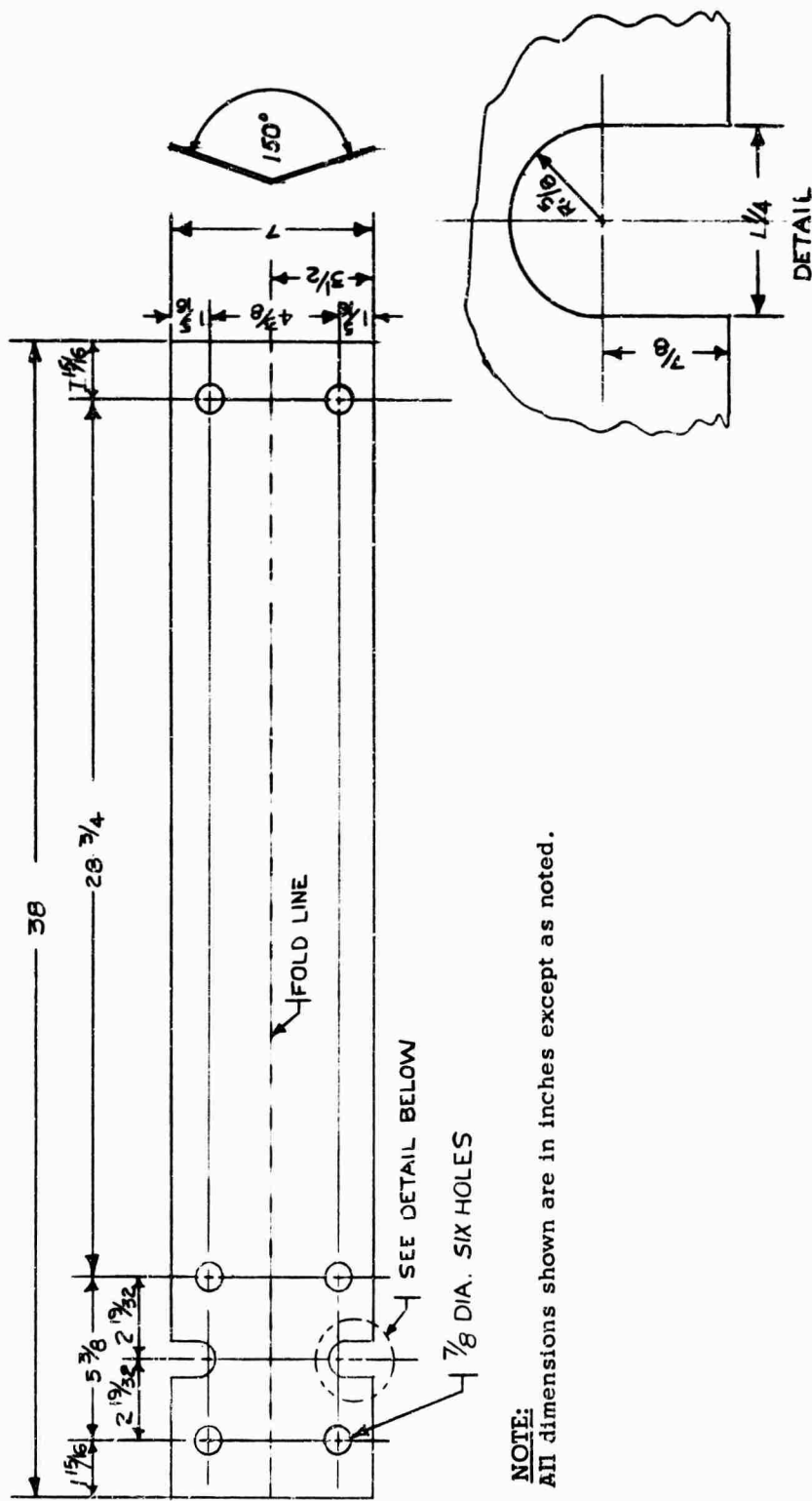

Fig. 5. Transverse stiffener, six-hole.

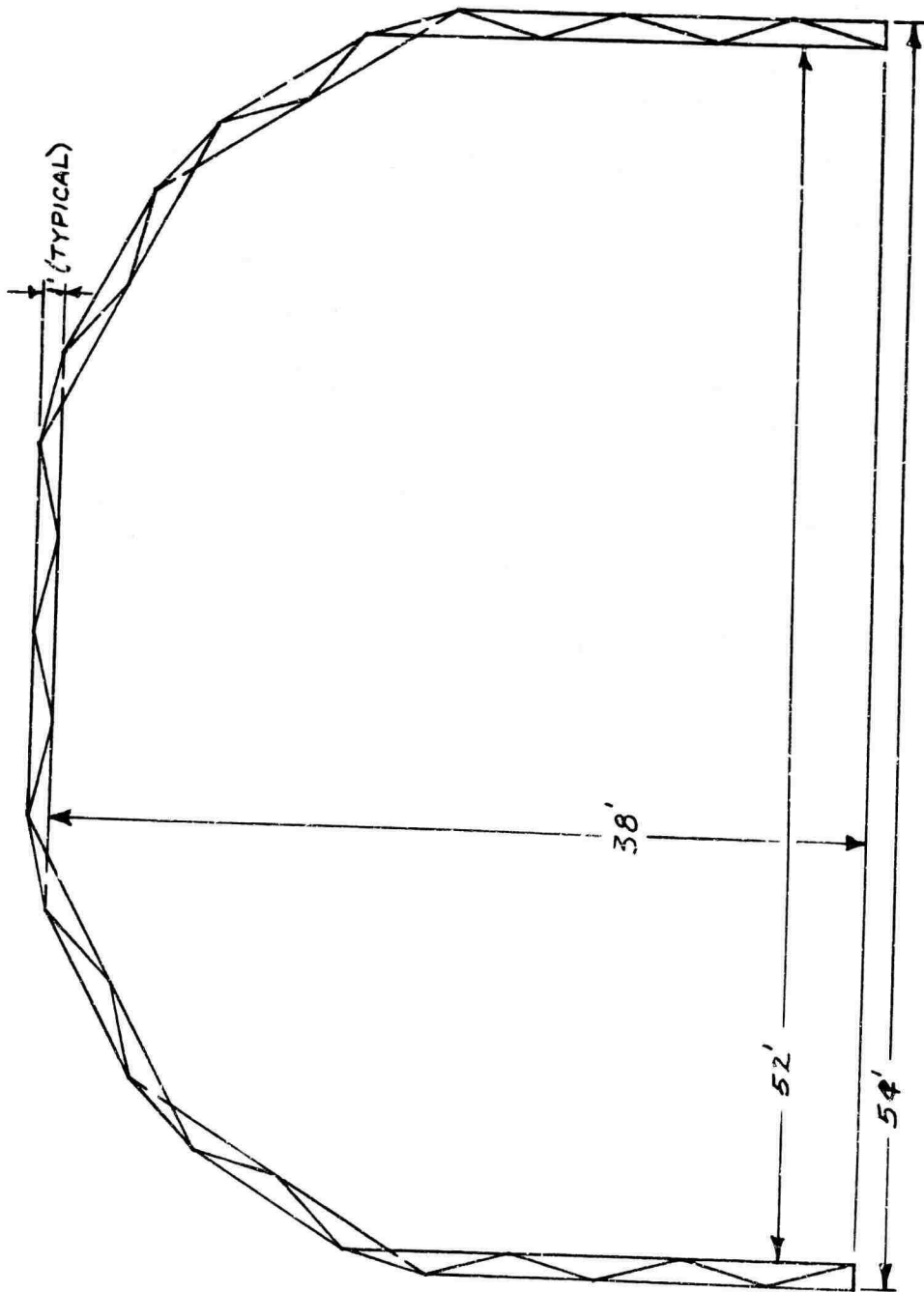

Fig. 6. Arch-type building configuration.

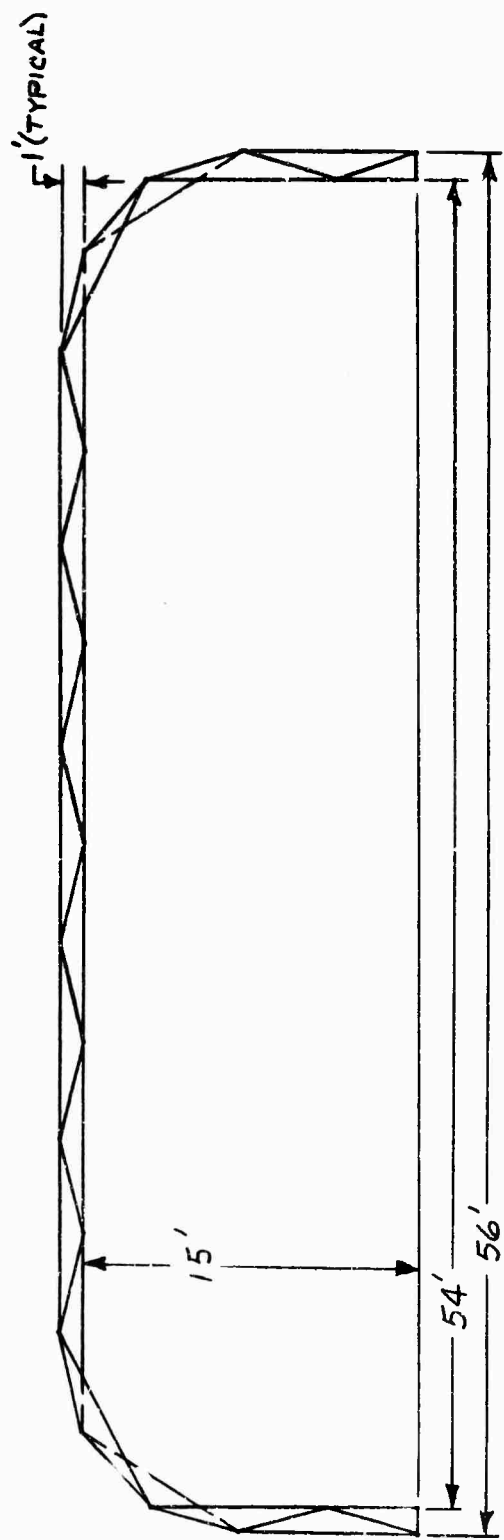

Fig. 7. Flat-roof building configuration.

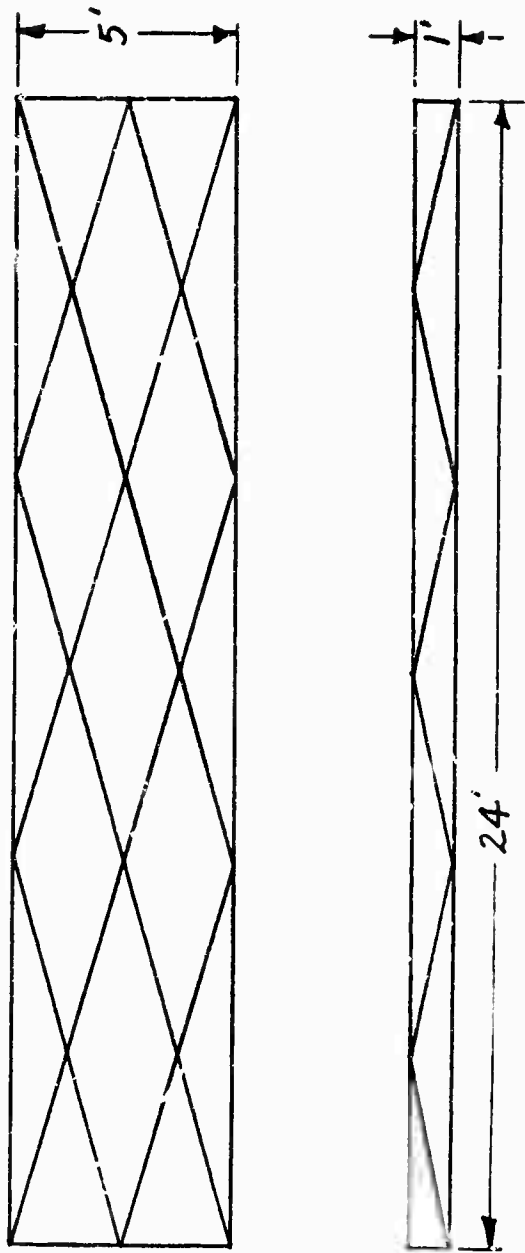

Fig. 8. UFP straight test beam.

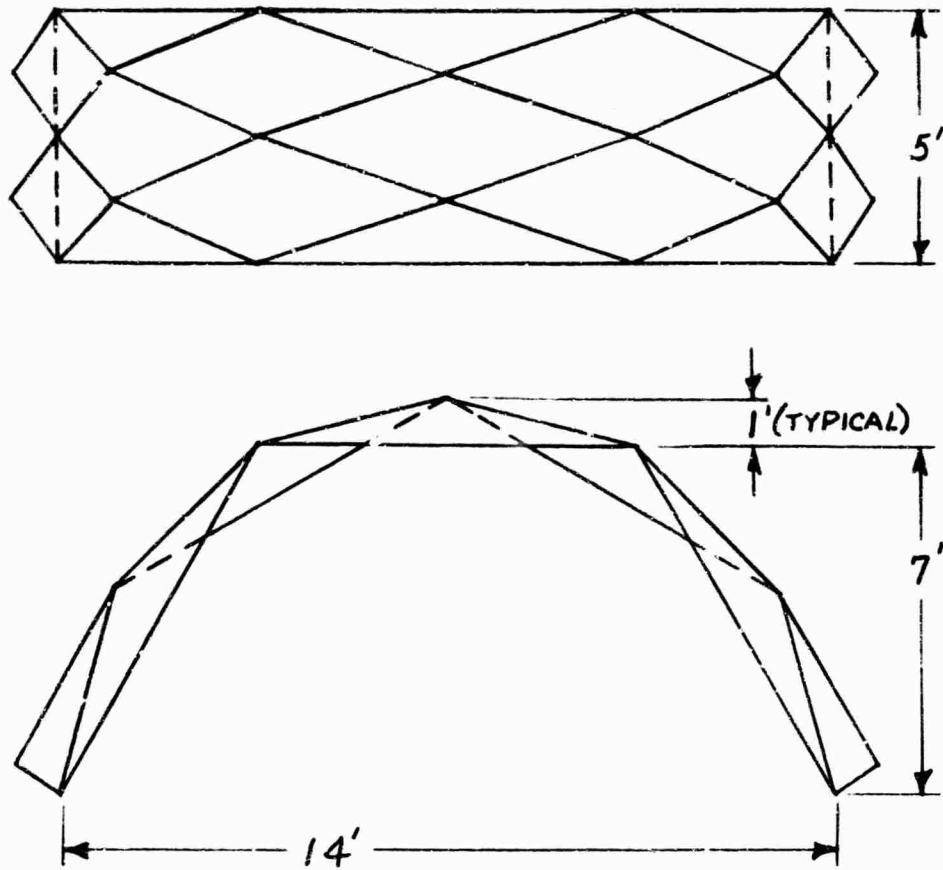

Fig. 9. UFP curved test beam.

a. **Erection Aids.** The equipment used during erection of the building and beam configurations is as follows:

- (1) Crane.
- (2) Forklift.
- (3) Portable generator.
- (4) Handtools (Fig. 10).

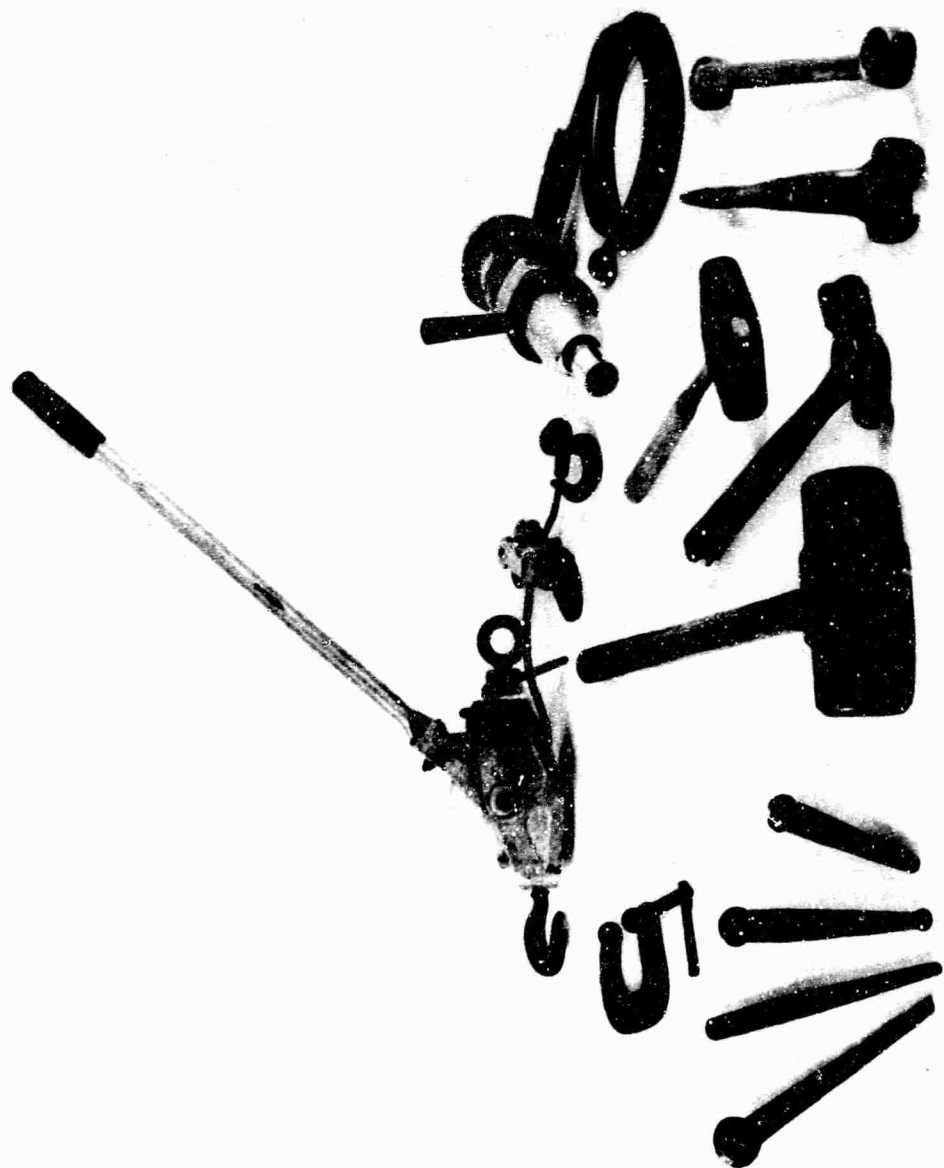

Fig. 10. Handtools.

S6846

- (5) Wooden horses.
 - (a) Three-ft height.
 - (b) Five-ft height.
- (6) Steel jack posts (height 4 ft 11 in. to 8 ft 4 in.).
- (7) Wire rope.
- (8) Steel Stakes, 3/4-in. diameter.

b. **Erection of Arch-Type Building.** This erection began at the base of one sidewall and progressed across the span of the building. The configuration was complete when the base was reached on the opposite sidewall. The transverse half panels form the base of the building. This base rests on whatever foundation is required for the building. The intermediate components of the building consist of the basic UFP unit (full panel) with the longitudinal half panel used to provide a straight edge along each end of the building.

The building length constructed during this erection was 16 UFP panel widths (approximately 40 ft). During this erection, a complete longitudinal row of panels was installed prior to the start of the next row. In this process, only a single UFP panel was bolted to the existing assembly at any one time. For this erection, a row of UFP panels was considered to be those panels in a line along the length of the building. Figure 11 shows the numerical order in which the rows of panels were installed to complete this arch-type building.

The first step in the erection of this arch-type configuration was to place the panels of row 1 (transverse half panels) in a line at the desired sidewall location. Row 2 of the panels (full panels) was next placed and leaned up onto wooden horses. These first two rows of individual panels were then bolted together to form one assembly (Fig. 12). Since the UFP panels are joined by nuts and bolts, men must work on both sides of the panels to fasten the panels together. For this purpose, the wooden horses were used as shown in Fig. 12. All bolts used in the assembly of this arch-type building were torqued with a 3/4-in.-drive electric impact tool. Torque was not measured.

The panels of row 3 were next installed into the assembly (Fig. 13). Each of these panels was individually placed and bolted to the panels of row 2. Transverse stiffeners and tie plates were installed across row 2 and row 3 as shown in Fig. 14. This is a typical transverse stiffener and tie plate installation for the entire building.

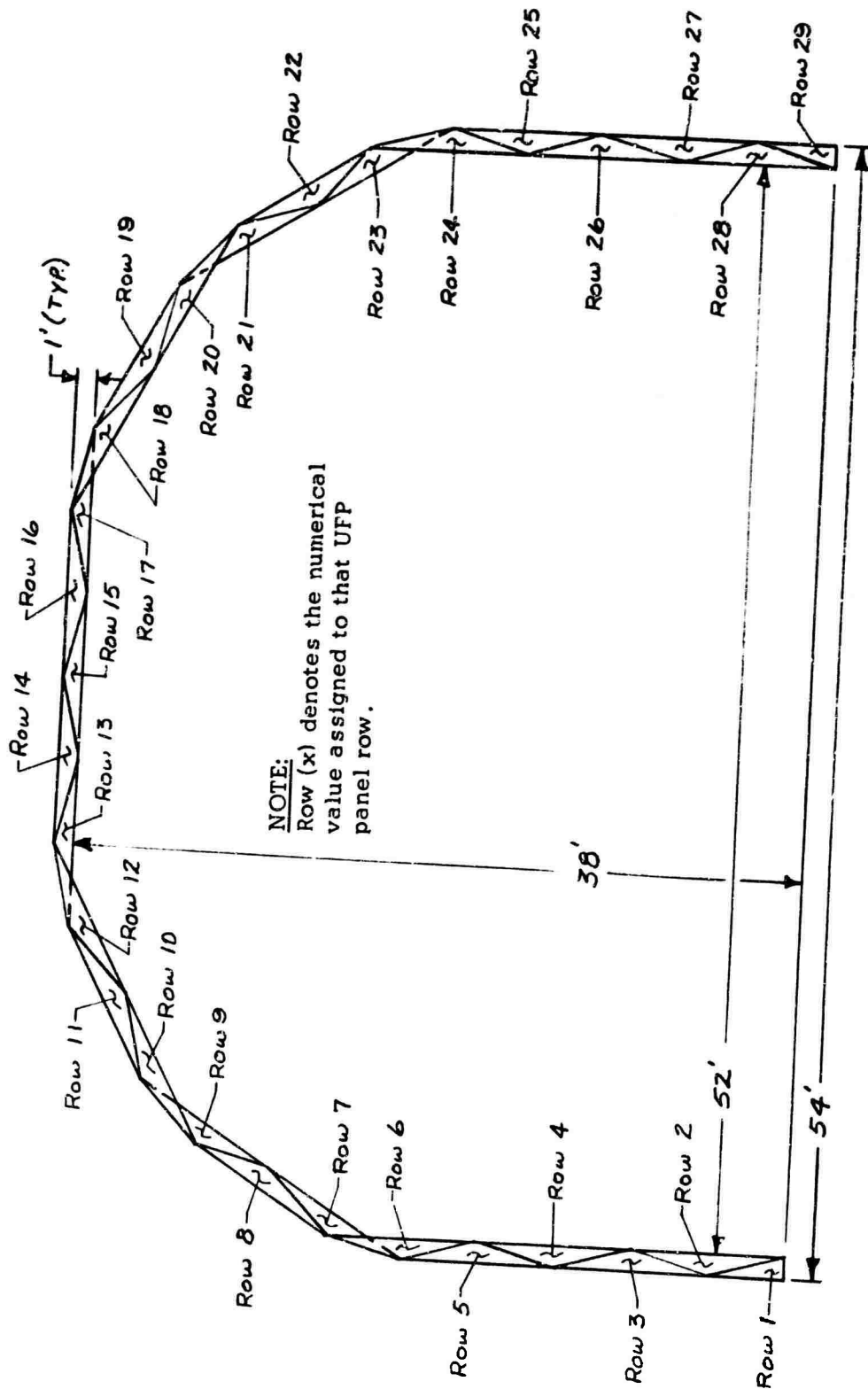

Fig. 11. Arch-type building configuration - order of panel installation.

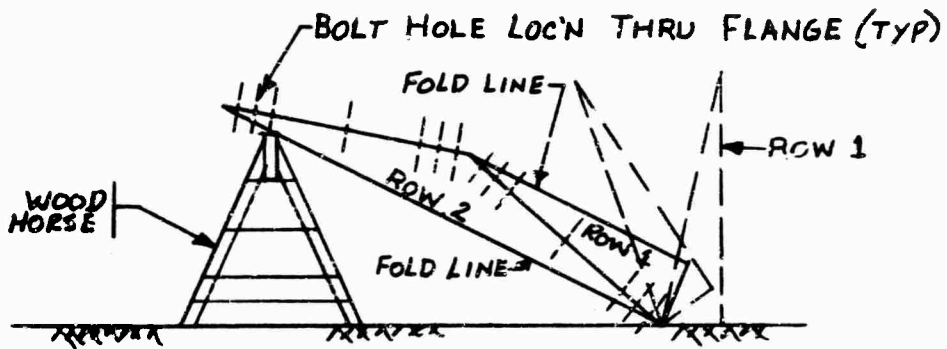

Fig. 12. Method of panel assembly.

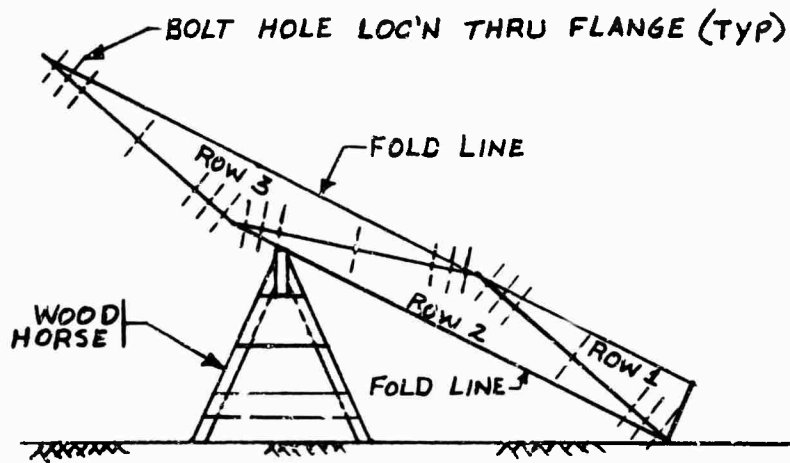
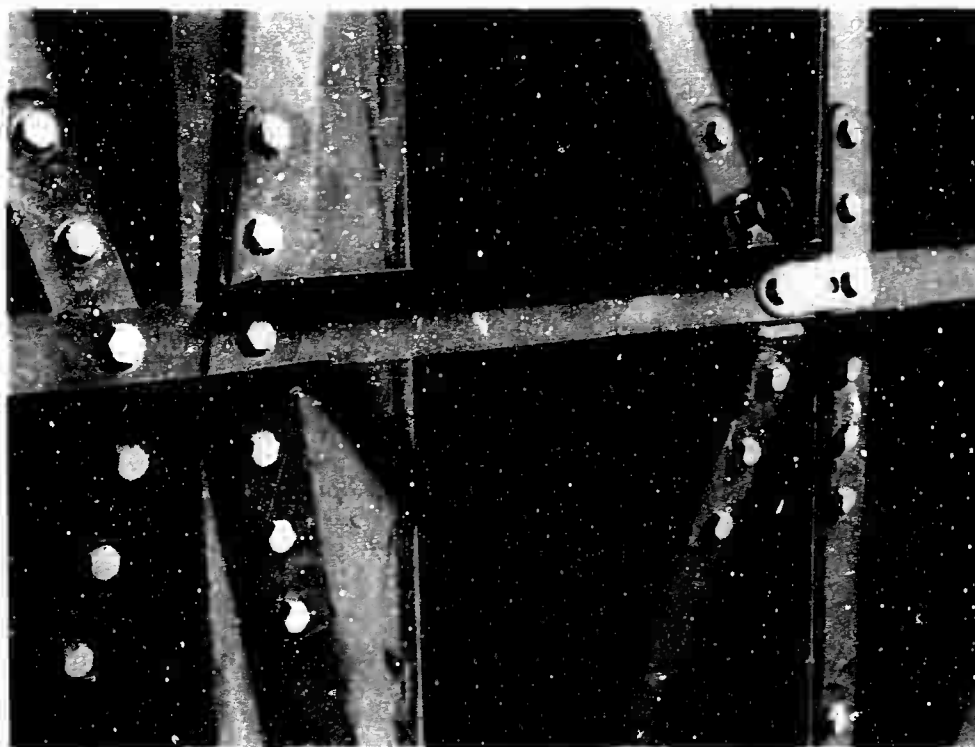

Fig. 13. Panel assembly continuation.



S5754

Fig. 14. Transverse stiffener installation.

Transverse stiffeners and tie plates were installed across each nodal point within this building.

The panels of row 4 were placed and bolted to the panels of row 3 using the same procedure as for the placing and bolting of the panels of row 3 to row 2. Each succeeding row of panels was added using the procedures as outlined until the panels of row 29 were installed into the assembly. See Figs. 15 through 28 for a pictorial description of erection steps in the order of events.

During erection, the leading edge of the structure assembly had to be raised periodically and the wooden horses relocated to facilitate further placement of panels. The lifting was accomplished using a crane with a seven-point wire rope sling attached to a 1-in.-diameter steel rod. This steel rod was attached to the panel assembly by eyebolts (3/4-in. standard shoulder eyebolt) placed along the 40-ft building length (Figs. 16 and 18). The eyebolts were installed in place of the regular bolts at nodal points as required.

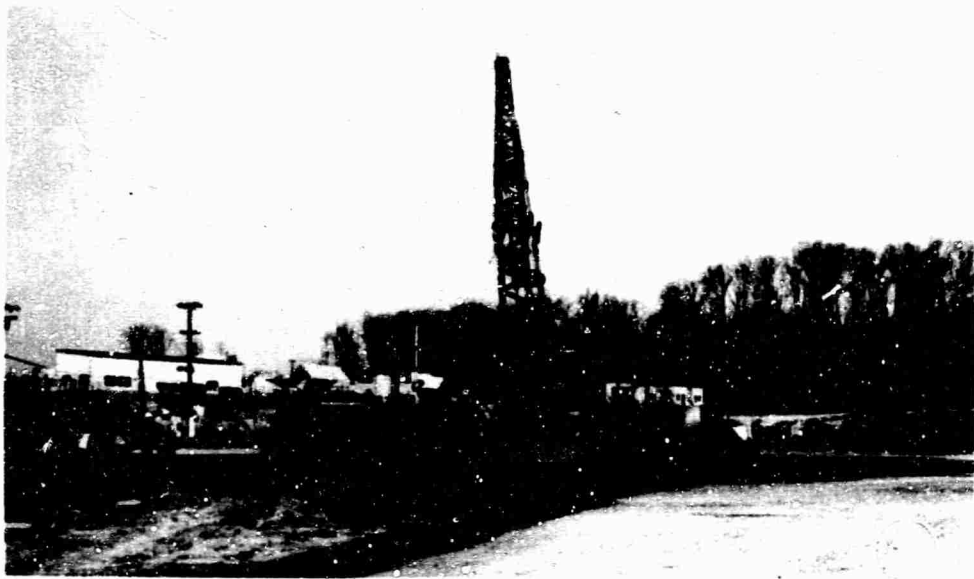

S3957

Fig. 15. Structure erection.

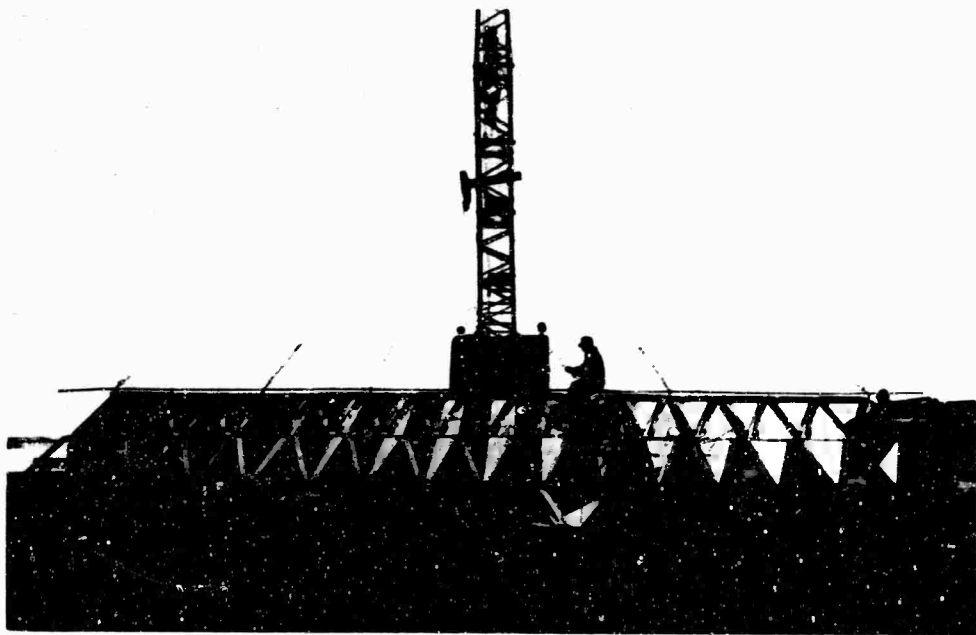

S3958

Fig. 16. Structure erection - cable sling adjustment.

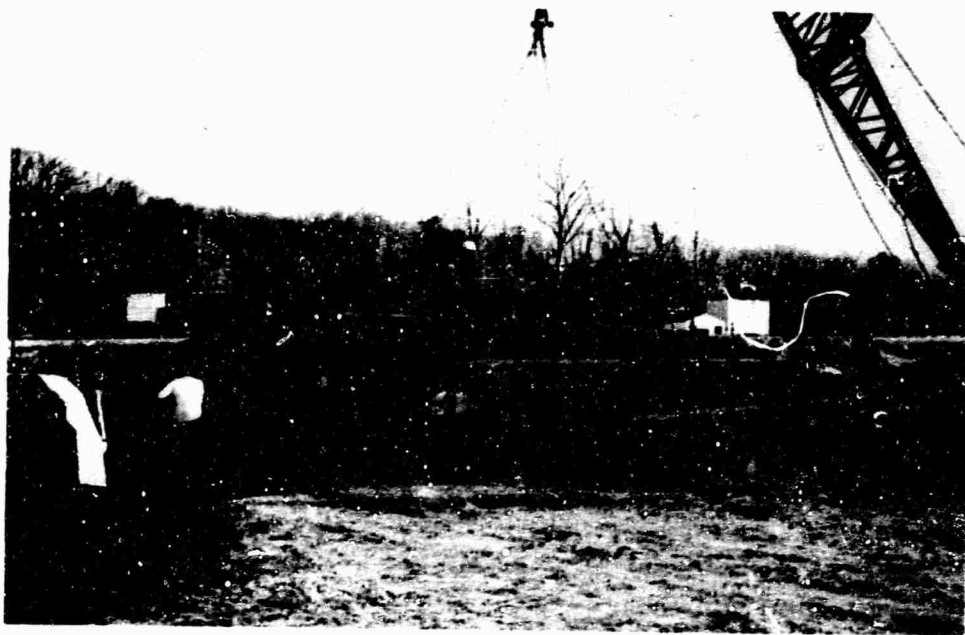

Fig. 17. Structure erection – 30 percent complete.

S3961

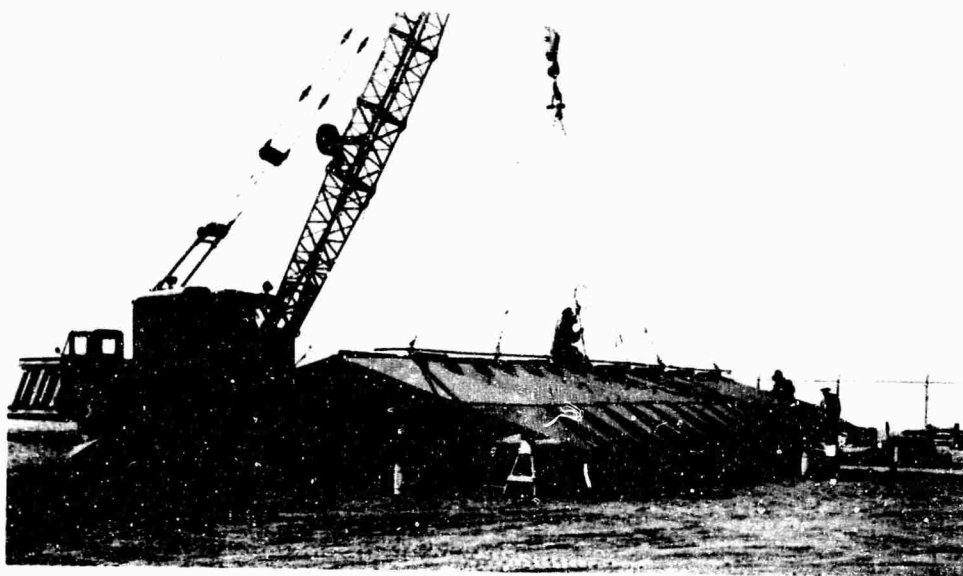
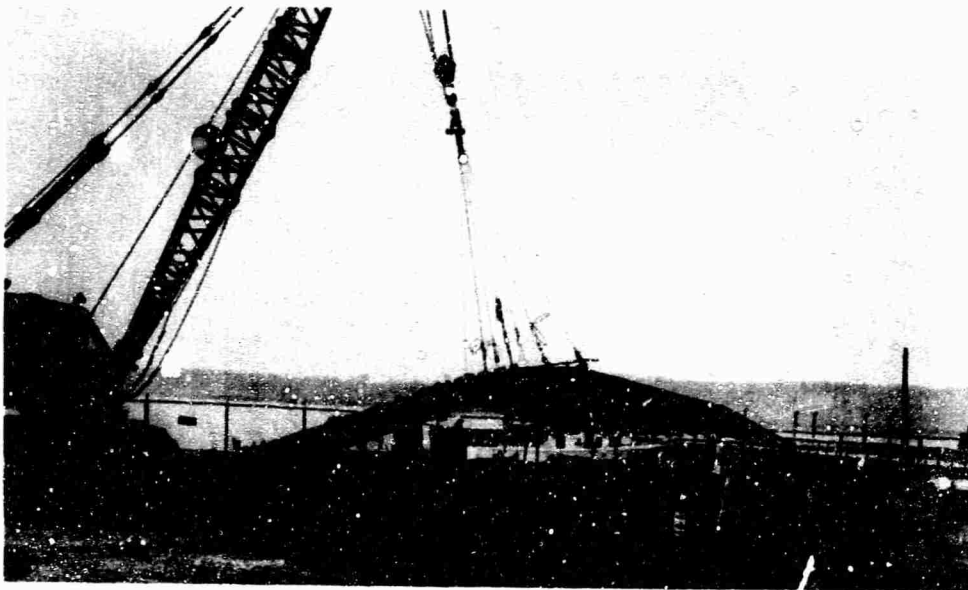

Fig. 18. Cable sling adjustment at 30-percent completion.

S3960



S3965

Fig. 19. Crane lift of structure at 30-percent completion.

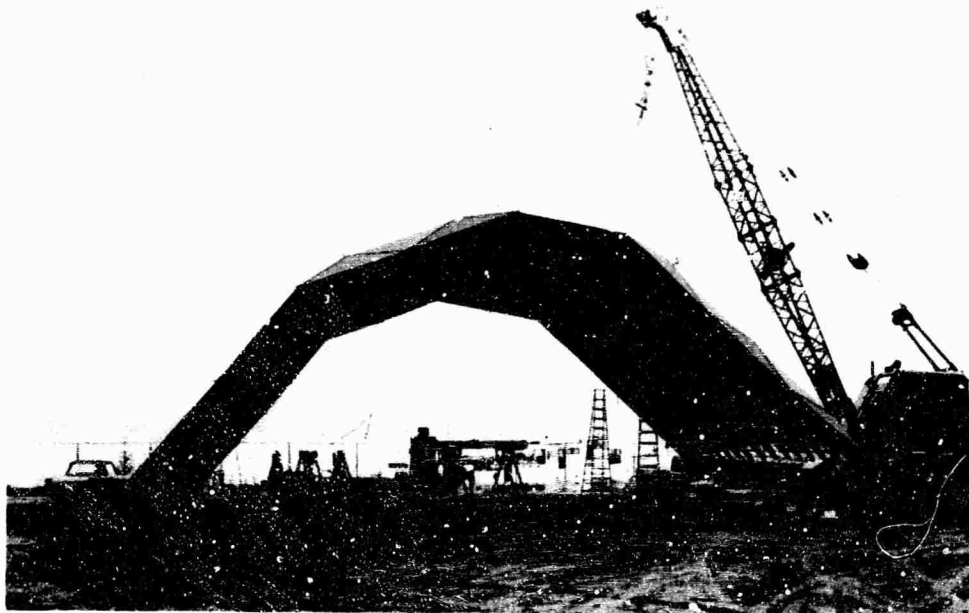

S4656

Fig. 20. Crane lift of structure at 60-percent completion.

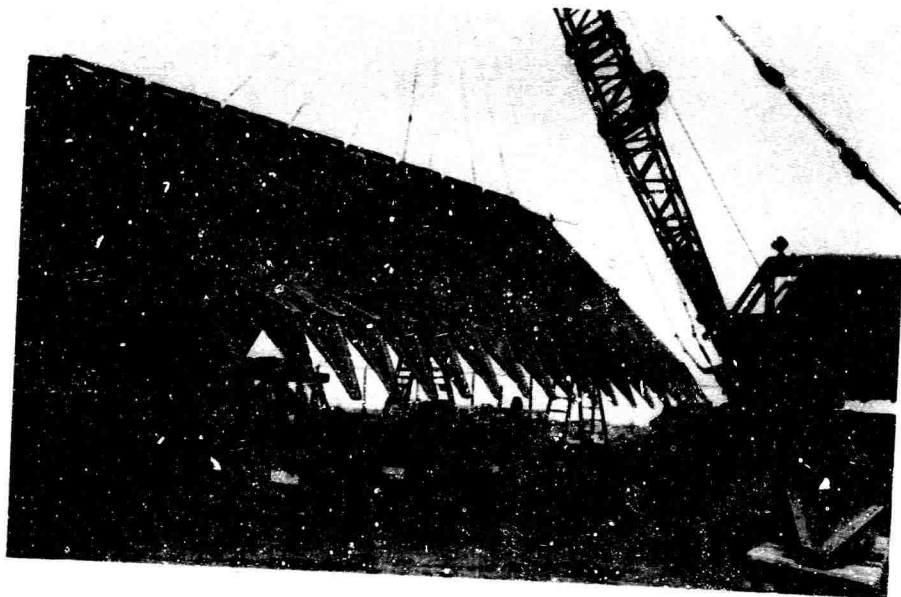

Fig. 21. Structure erection – 60 percent complete.

S4658

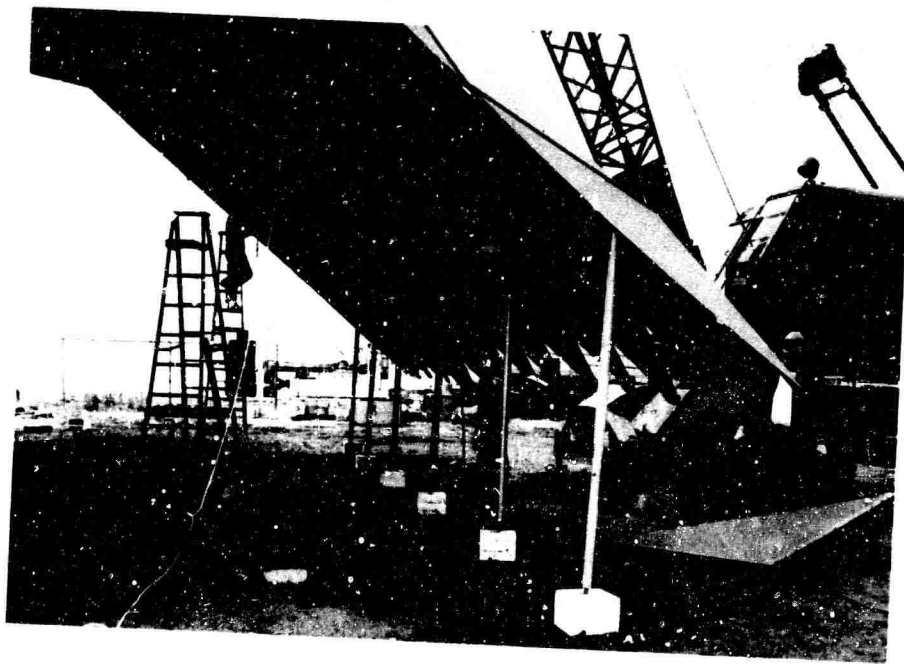
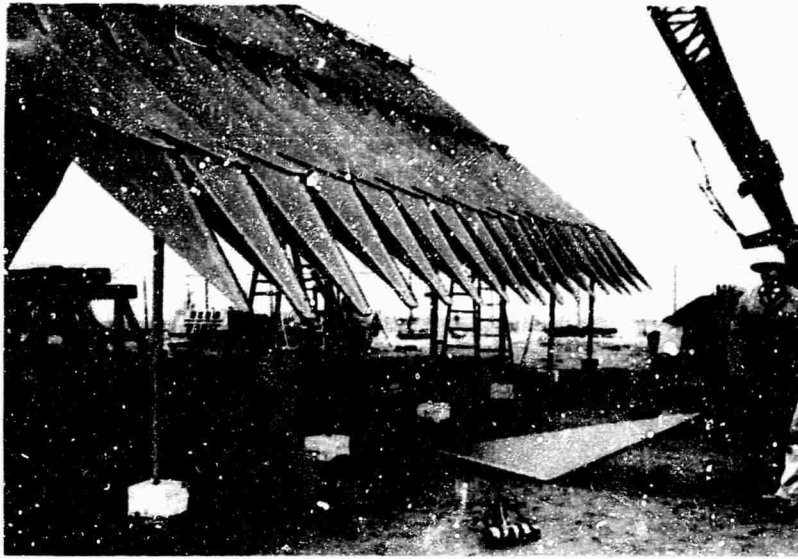

Fig. 22. Structure 70 percent complete – jack-supported.

S4659



S4661

Fig. 23. Structure erection – 70 percent complete.

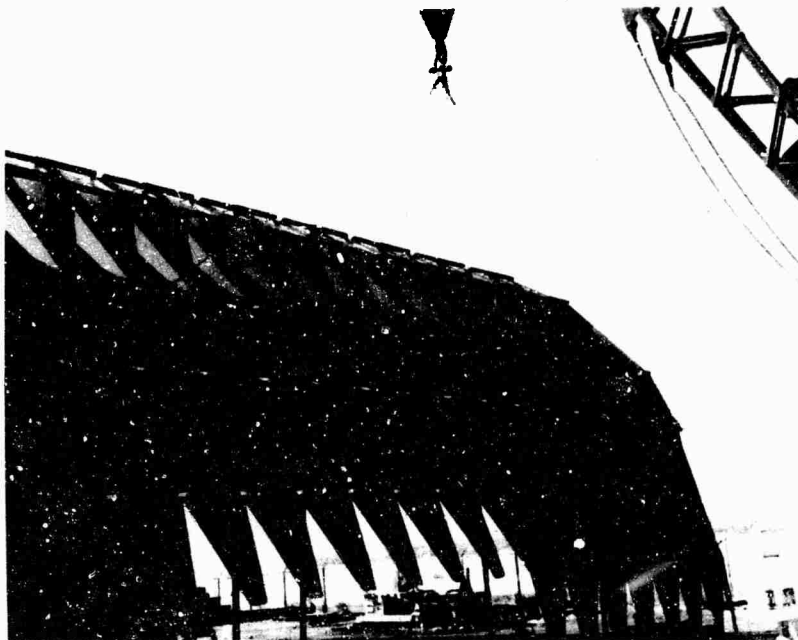

S4649

Fig. 24. Structure erection – 85 percent complete.

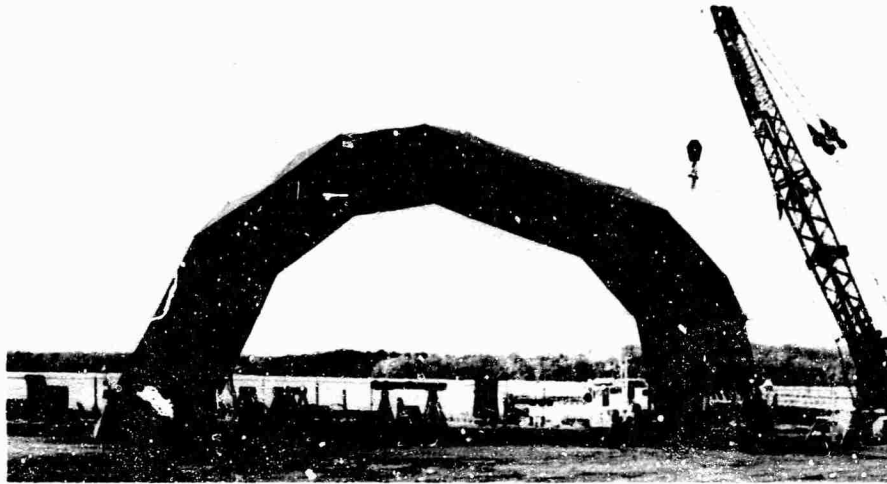

S4650

Fig. 25. Structure 85 percent complete – end view.



S5207

Fig. 26. Structure complete – sidewall not positioned.

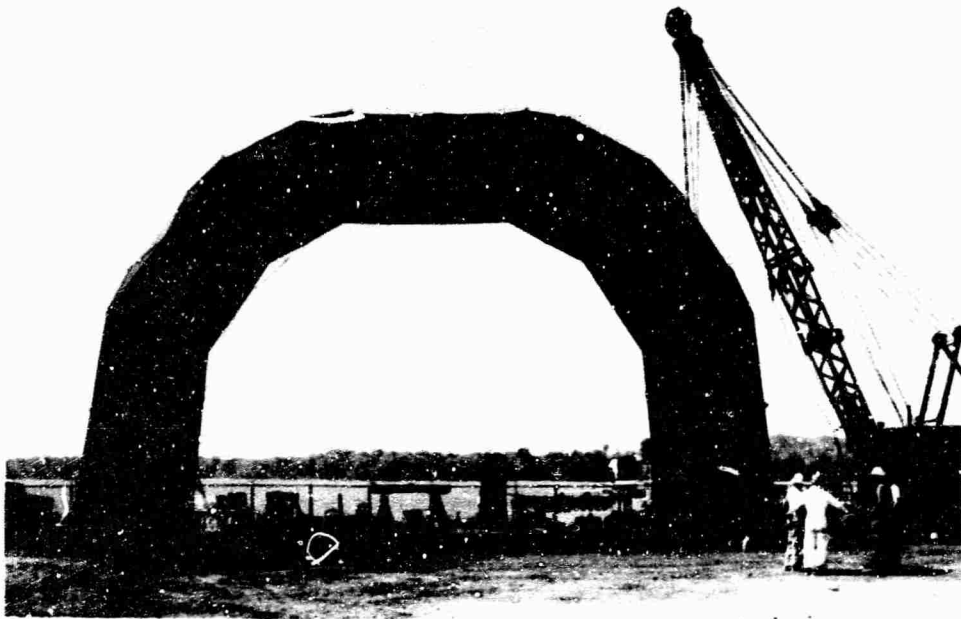

S5208

Fig. 27. End view – sidewalls not positioned.

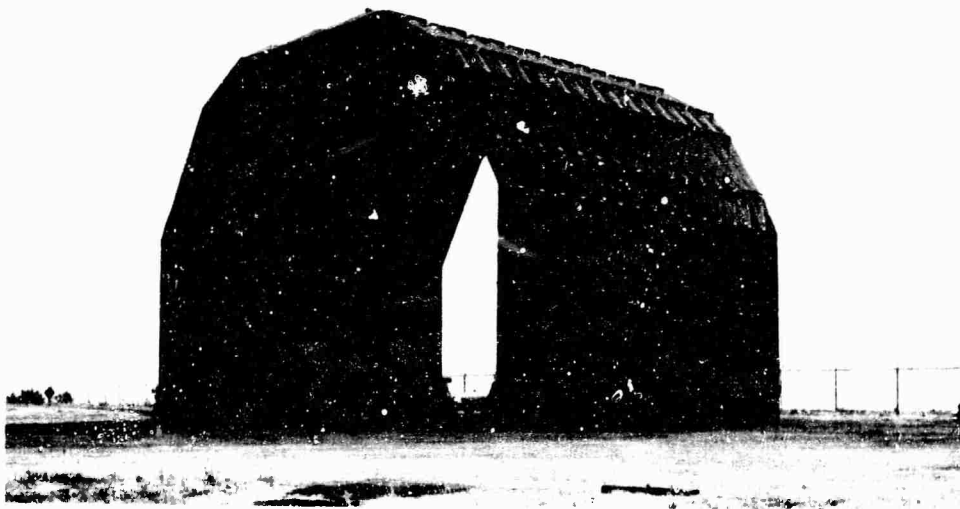

S5210

Fig. 28. Complete structure.

As erection progressed, the wooden horses became ineffective as a support for the panel assembly while additional rows of panels were installed because of the size and configuration of the building. At this time, steel jack posts replaced the wooden horses. Six jack posts were found to hold the panel assembly in approximately a level line along the row of panels (Fig. 22). The crane was still necessary to lift the panel assembly for lift heights in excess of 6 in. because of the limited length of screw adjustment.

During installation of panels, alignment of bolt holes proved difficult at times. The location of difficult hole alignment within a panel row followed no set pattern from one row to the next. Some panels were placed with little or no interference for bolt installation while others required the use of driftpins and sledgehammers to obtain hole alignment. In some instances, bolts were threaded through partially aligned holes in order to obtain the bolt installation. The order of panel placement within a row was varied during assembly without any improvement of interference. The most difficult hole alignment generally existed along the row of transverse stiffeners.

After all of the panels, transverse stiffeners, and tie plates were installed, the sidewalls were aligned and anchored to the ground. There was no special foundation preparation intended in the area of the sidewall bases. The approximately level ground was used, as it existed, as a foundation. Since the existing ground was to be the only foundation used, the panels (transverse half panels) of rows 1 and 29 were anchored to the ground by 3/4-in.-diameter steel stakes (Fig. 29). One steel stake was

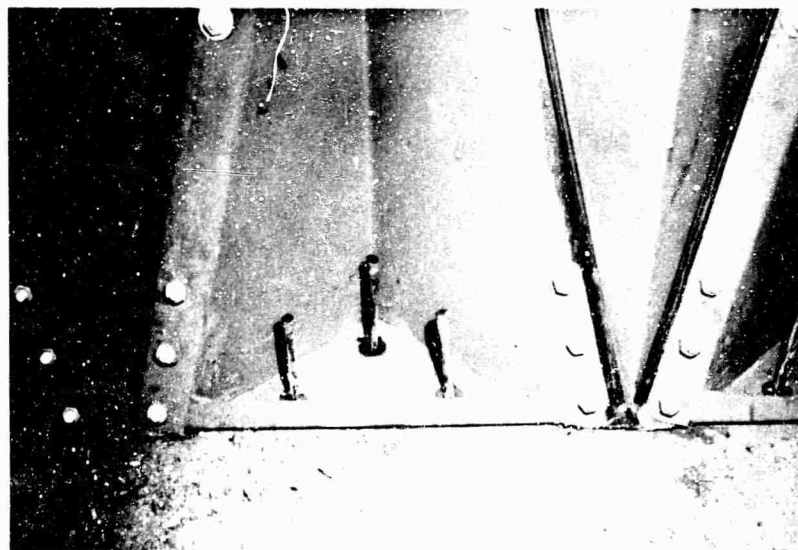

S5212

Fig. 29. Foundation anchor installation.

driven through each of the three 7/8-in.-diameter holes provided in the base plate of each transverse half panel. The steel stakes were driven into the ground to a depth of 18 in. with a stop provided at this depth. The sidewall containing panels of row 29 was staked to the ground with row 1 panels remaining free. The panels of row 29 were aligned to form a straight line, and the steel stakes were driven into the ground. This maintained a fixed position for the sidewall containing row 29 panels. Next, the sidewall containing row 1 panels was positioned in its intended location and staked to the ground. Since the arch-type building span grew approximately 8 ft during construction, a crane was used to lift the second sidewall vertically while two forklifts moved the base horizontally into the required position. Alignment of the second sidewall was accomplished by measurements taken with a steel tape from the first sidewall staked to the ground. Location of the sidewalls was approximate and not exact.

c. **Erection of Flat-Roof Building.** The erection of this building consisted of constructing two separate assemblies. The configuration was complete when the two assemblies were joined and the base (sidewalls) was positioned. The UFP panels used in the construction of this building were identical to those used for the arch-type building.

The building length constructed during this erection was 10 panels wide (approximately 25 ft). One assembly consisted of panels row 1 through row 16; the other assembly consisted of panels row 1-1 through row 1-5 (Fig. 30).

Individual panels and rows of panels were placed in the same manner as for erection of the arch-type building; i.e., row 1 and row 1-1 (Fig. 30) were placed first in each of the two assemblies. Both assemblies were completed prior to joining to form the flat-roof building configuration. The erection procedures and construction methods employed were similar to those performed during the erection of the arch-type building.

Erection of the assembly containing rows 1 through 16 proceeded as shown in Figs. 31 through 34. The assembly containing rows 1-1 through 1-5 is shown in its completed form in Fig. 35.

Joining of the two assemblies into the flat-roof building was accomplished as shown in Figs. 36 through 42. Two cranes were used to position the two assemblies so that the mating flanges of the panels in row 1 and row 1-5 could be bolted together. After the two assemblies were connected, the base panels were aligned and staked in the same manner as for the arch-type building. The completed flat-roof building is shown in Fig. 43.

NOTE:
Row (x) denotes the numerical value assigned to that UFP panel row.

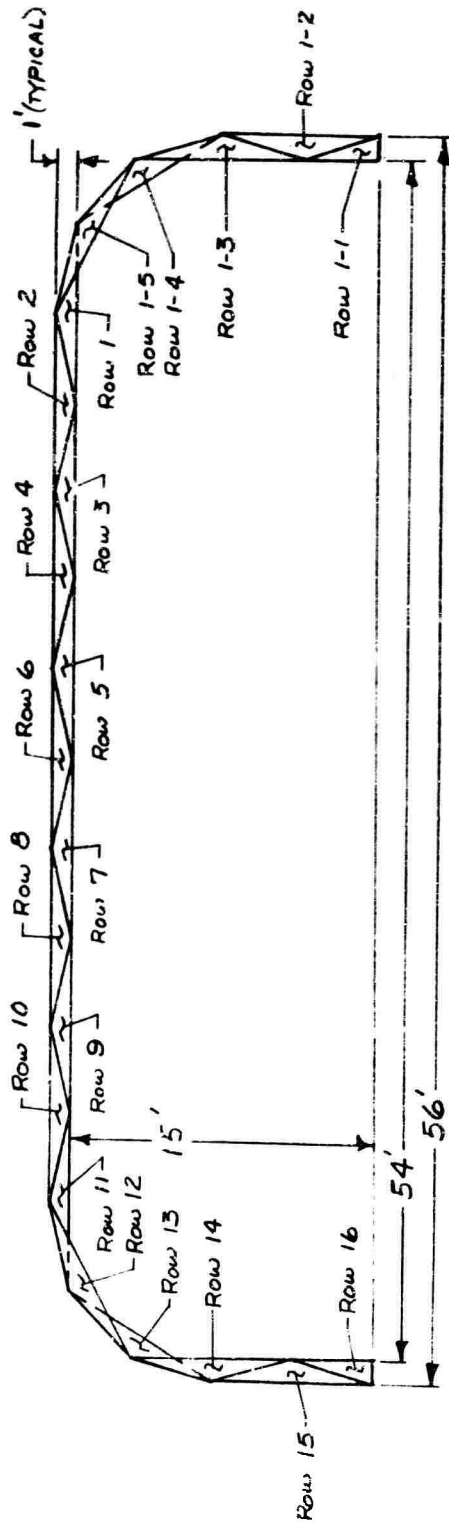

Fig. 30. Flat-roof building configuration — order of panel installation.

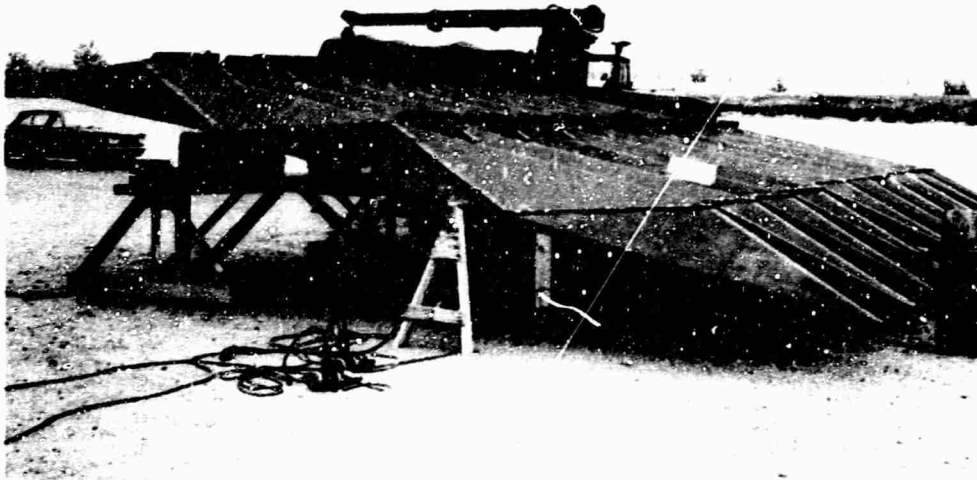

Fig. 31. Flat roof – 50 percent complete.

S5218

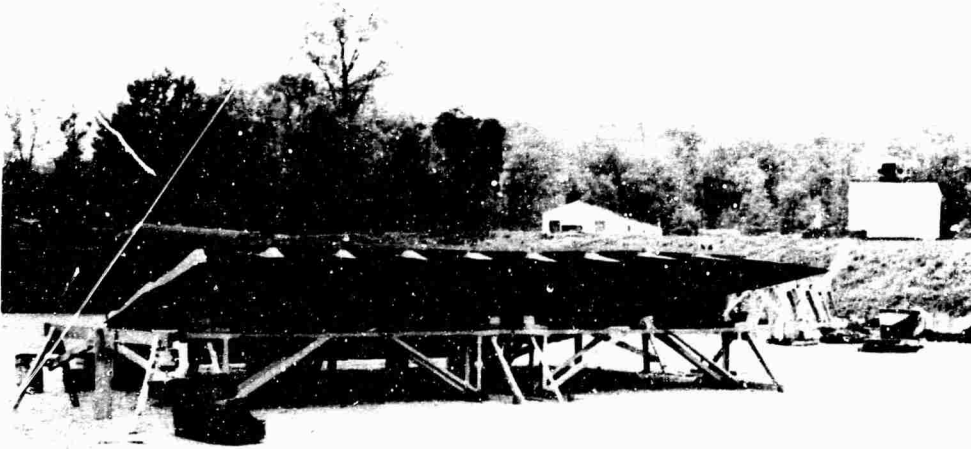

Fig. 32. Roof supports – 50 percent complete

S5217

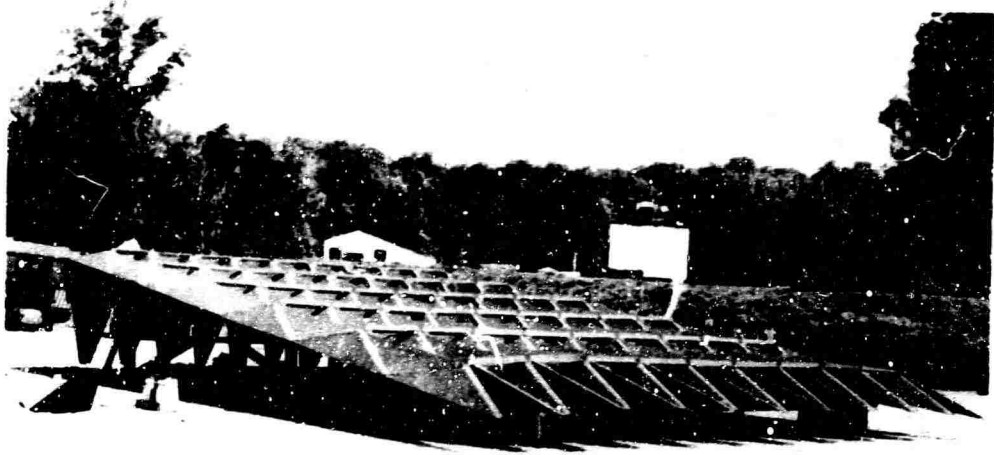

Fig. 33. Flat roof complete — sidewall 40 percent complete.

S5225

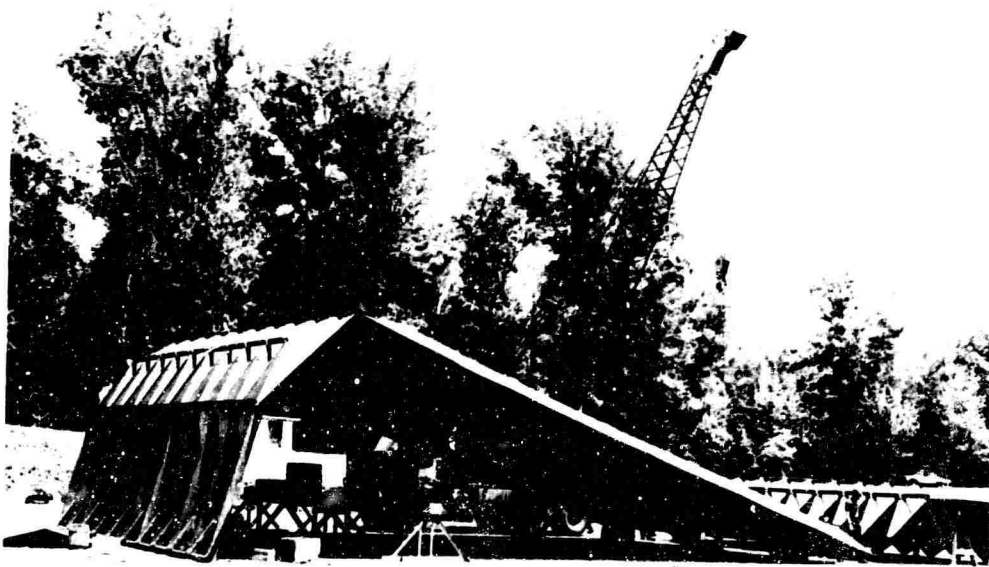

Fig. 34. Sidewall-roof complete — preparation for crane lift to join second sidewall.

S5193



S5194

Fig. 35. Flat roof and sidewall completed.

During erection of the flat-roof building, the rubber sealant gasket was stripped off of approximately one-half the UFP panels used. These panels without sealant gaskets were placed together across the building span during erection. After erection was complete, caulking (FSN 8030-682-6422) was applied to the joints without gaskets as shown in Figs. 44 and 45.

After the flat-roof building was complete, the original transverse stiffeners and tie plates were removed and replaced with the six-hole transverse stiffener (Fig. 5). During the installation of the six-hole transverse stiffeners, bolt hole misalignment proved to be a problem. A forklift, driftpins, sledgehammer, and cable hoist were used to get hole alignment for bolt installation. The least amount of misalignment was encountered when a row of the original transverse stiffeners was removed and then the six-hole transverse stiffeners were installed prior to any further removal. (See Fig. 46 for typical six-hole transverse stiffener installation.)

Vertical sag existed in the flat roof after erection was complete. Vertical sag was measured along the span centerline at each end and at the center. The

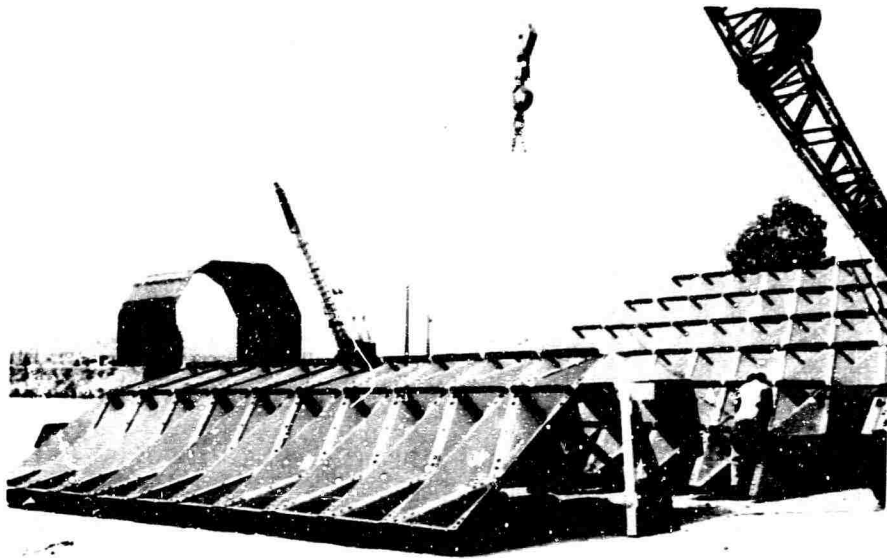

Fig. 36. Sidewall and flat roof prior to mating.

S5191

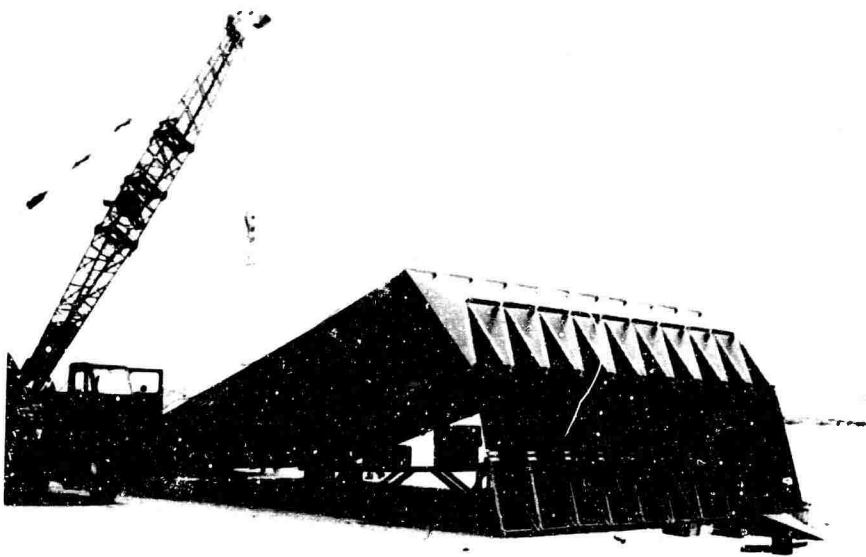
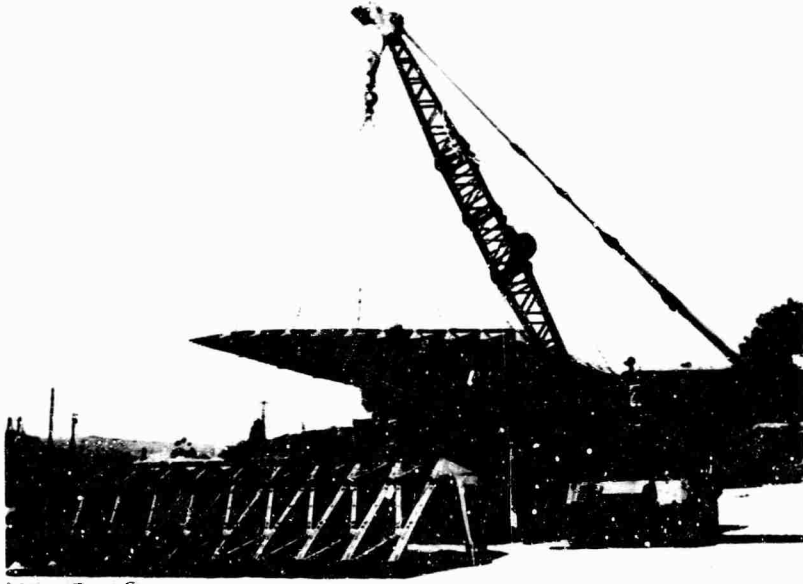

Fig. 37. Preparation for crane lift of roof-wall combination.

S5192



S5197

Fig. 38. Flat roof raised to position for building completion.

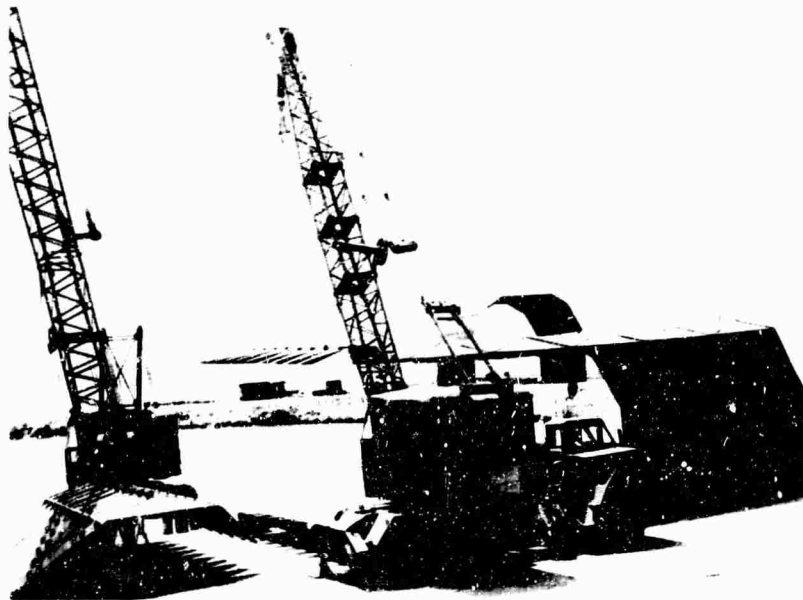

S5202

Fig. 39. Flat roof raised — preparation to position sidewall.

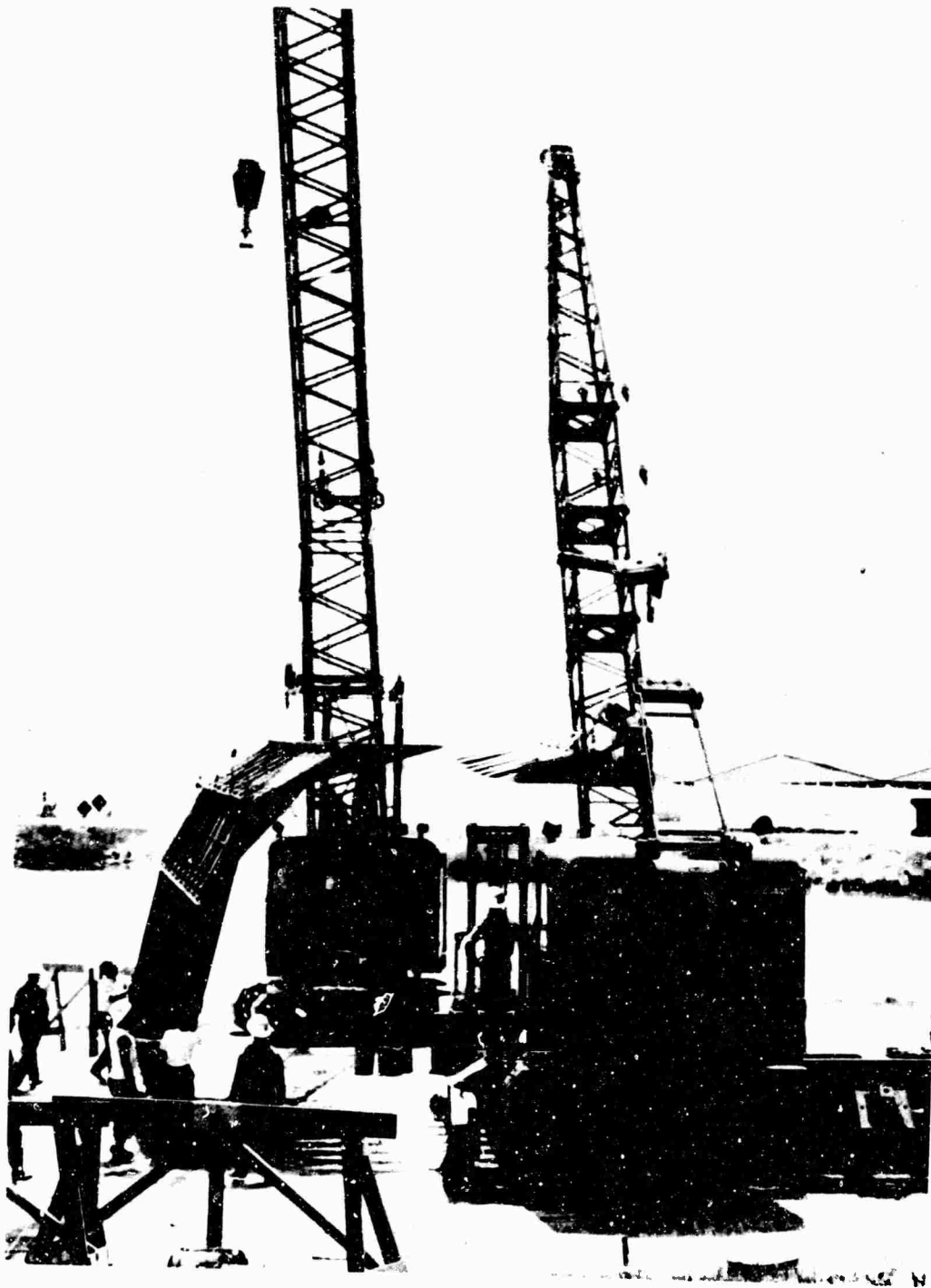
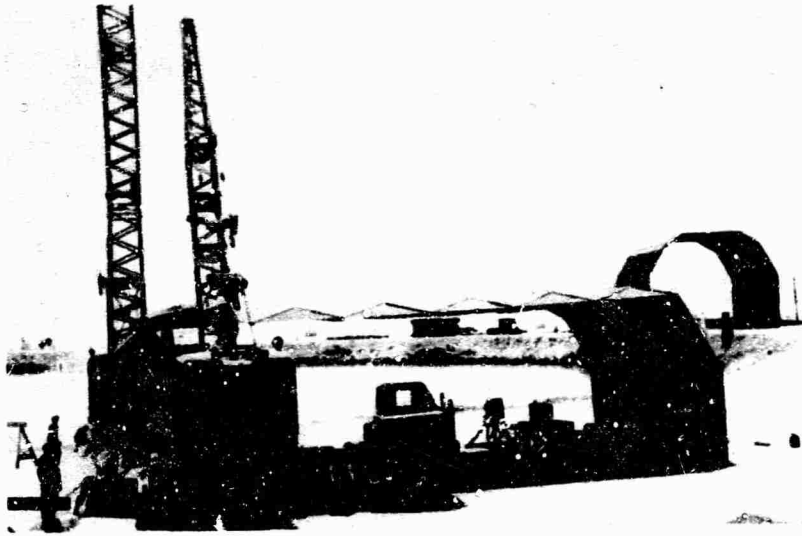

Fig. 40. Roof and sidewall prior to mating.

S7561



S5185

Fig. 41. Roof-sidewall set together prior to bolt installation.

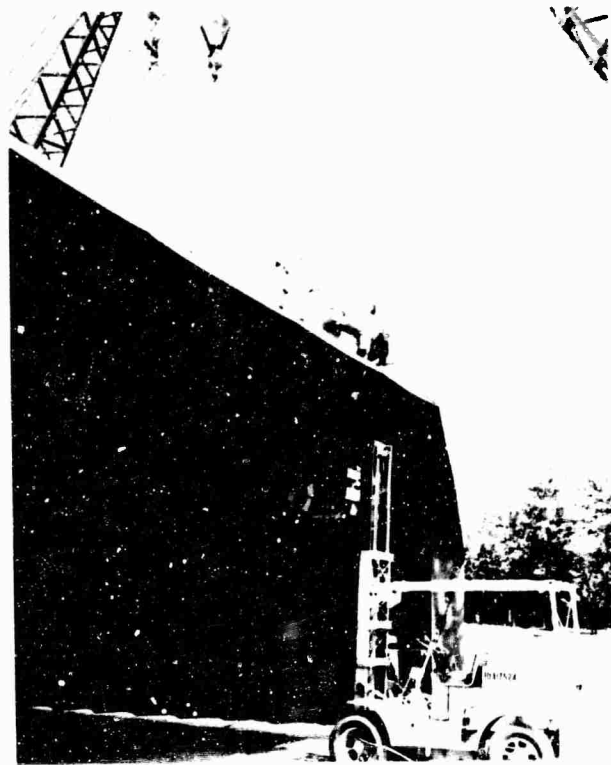

S5190

Fig. 42. Installation of bolts for joining of roof to sidewall.



S5748

Fig. 43. Complete structure.



S5749

Fig. 44. Caulking application.

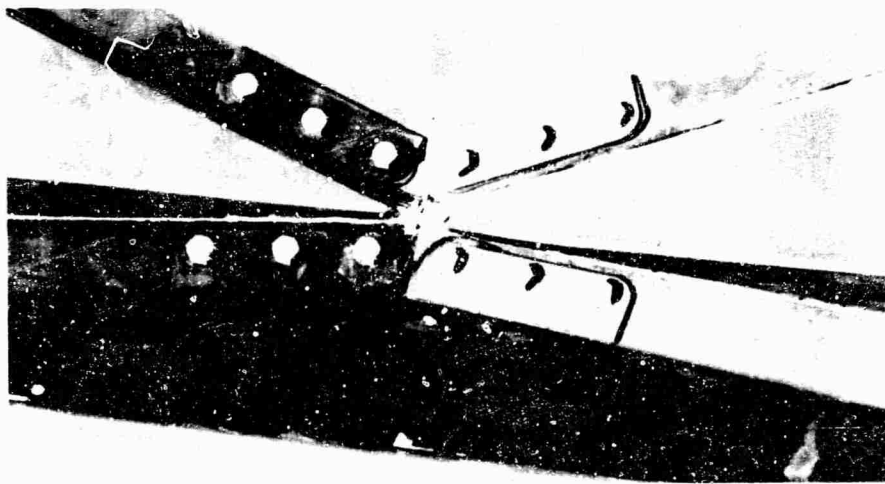

S5750

Fig. 45. Caulked joints.

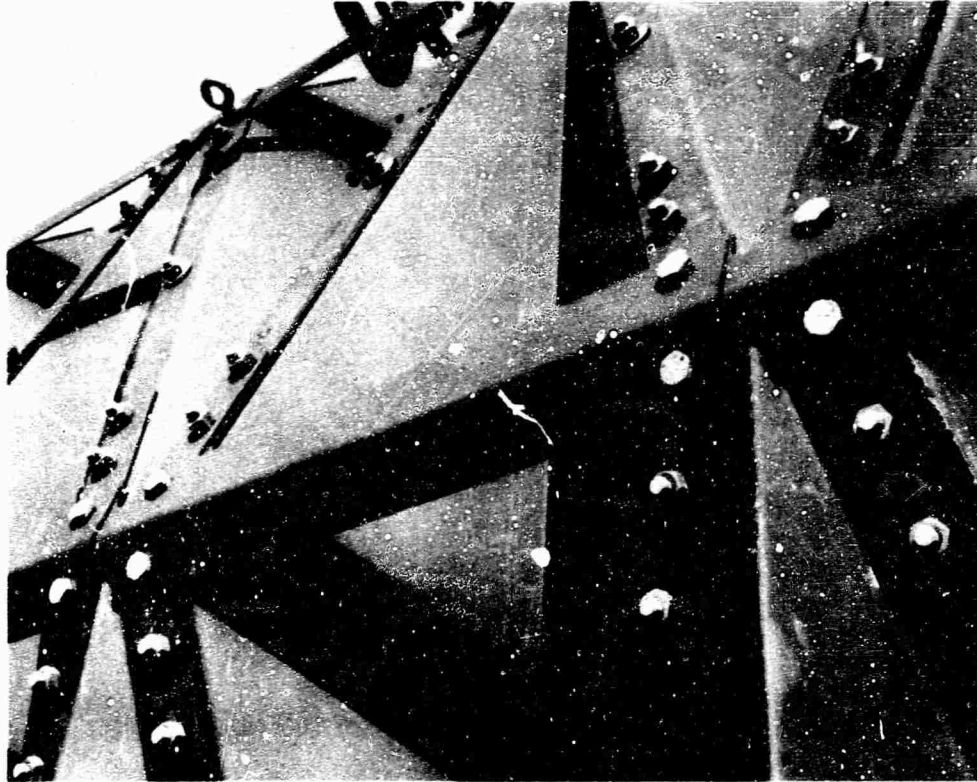

S5756

Fig. 46. Six-hole transverse stiffener installation.

amount of vertical sag was as follows:

- (1) Near side = 6 in.
- (2) Center = 4-5/8 in.
- (3) Far side = 5-1/4 in.

6. **Test Procedures.** The structural configurations erected were to be subjected to test loads. The results of test load application were to serve as a measure of the structural adequacy of the UFP system and to provide a basis for evaluation to determine potential military use. Failures or areas of weakness would be reevaluated, modified, and retested within the limits of time, personnel, and funds available for this test. The plan of test is included as an appendix to this report. Any variation from the plan of test is as shown within the content of this report.

Test loads were applied in various increments. Strain gages were applied at predetermined locations of the arch-type structure and the flat-roof structure. SR-4 strain gage readings, horizontal deflections, and vertical deflections were recorded after application of each load increment. Horizontal deflections were monitored on each vertical wall, and vertical deflections were measured along the span centerline. The horizontal and vertical deflections were obtained by stadia rod readings using a surveyor's transit.

a. **Test Equipment.** The following is a list of test equipment used during test of both structures.

- (1) SR-4 strain gages.
- (2) Strain gage readout equipment.
- (3) Survey transit and stadia rod.
- (4) Wind velocity meters.
- (5) Dynamometers.
- (6) Scales.
- (7) Cable hoist.
- (8) Forklift.
- (9) Cranc.
- (10) Hi-Ranger (truck-mounted servicing platform for personnel movement).
- (11) Aircraft engine with propeller.
- (12) Sandbags.
- (13) Parachute harness (used as safety device).

b. **Test Loads.**

- (1) The test loads applied to the arch-type (Fig. 6) and flat-roof (Fig. 7) structural configurations were the design live loads multiplied by the factor of

safety. The design loads were as follows:

(a) Dead load = 10 psf.

(b) Live load. This required load condition of snow load, wind load, and combinations of snow and wind loads as shown below.

1. 100% snow load = 25 psf.
2. 100% wind load = 80 – 100 mph.
3. 25-psf snow load + 50-mph wind load.
4. 100-mph wind load + 12.5-psf snow load.

(c) Factor of safety = 1.25.

(2) The test loads applied to the test-beam (Fig. 8 and Fig. 9) structural configurations were those static loads of a magnitude to produce structural failure.

c. **Arch-Type Building Load Application.** After application of the initial load increment and each successive load increment, strain gage readings, horizontal deflections, and vertical deflections were recorded. Strain gage locations are shown in Fig. 47, and typical strain gage wirings are shown in Figs. 48 and 49. Horizontal stadia rods were placed on both walls at a height of 20 ft above ground level at approximately 2.5 ft from each end and at the center of one wall (Fig. 50). Vertical stadia rods were hung by wires along the span centerline at approximately 2.5 ft from each end and at the center (Fig. 50).

(1) **Snow Load.** The test snow loading for this building configuration was simulated by placing sandbags on the roof area shown in Fig. 51. The sandbags were weighed, placed on a steel pallet, and raised to the rooftop of the building by a crane (Fig. 52). Men distributed the sandbags uniformly over the load area (Figs. 53 and 54). The Hi-Ranger vehicle was used to elevate the men to the roof (Figs. 55 and 56). Once on the roof, the men were tied to 1/2-in. nylon safety ropes from the crane to the safety harness on each man. The simulated snow load was applied in the following increments:

(a) 10 psf.

(b) 15 psf.

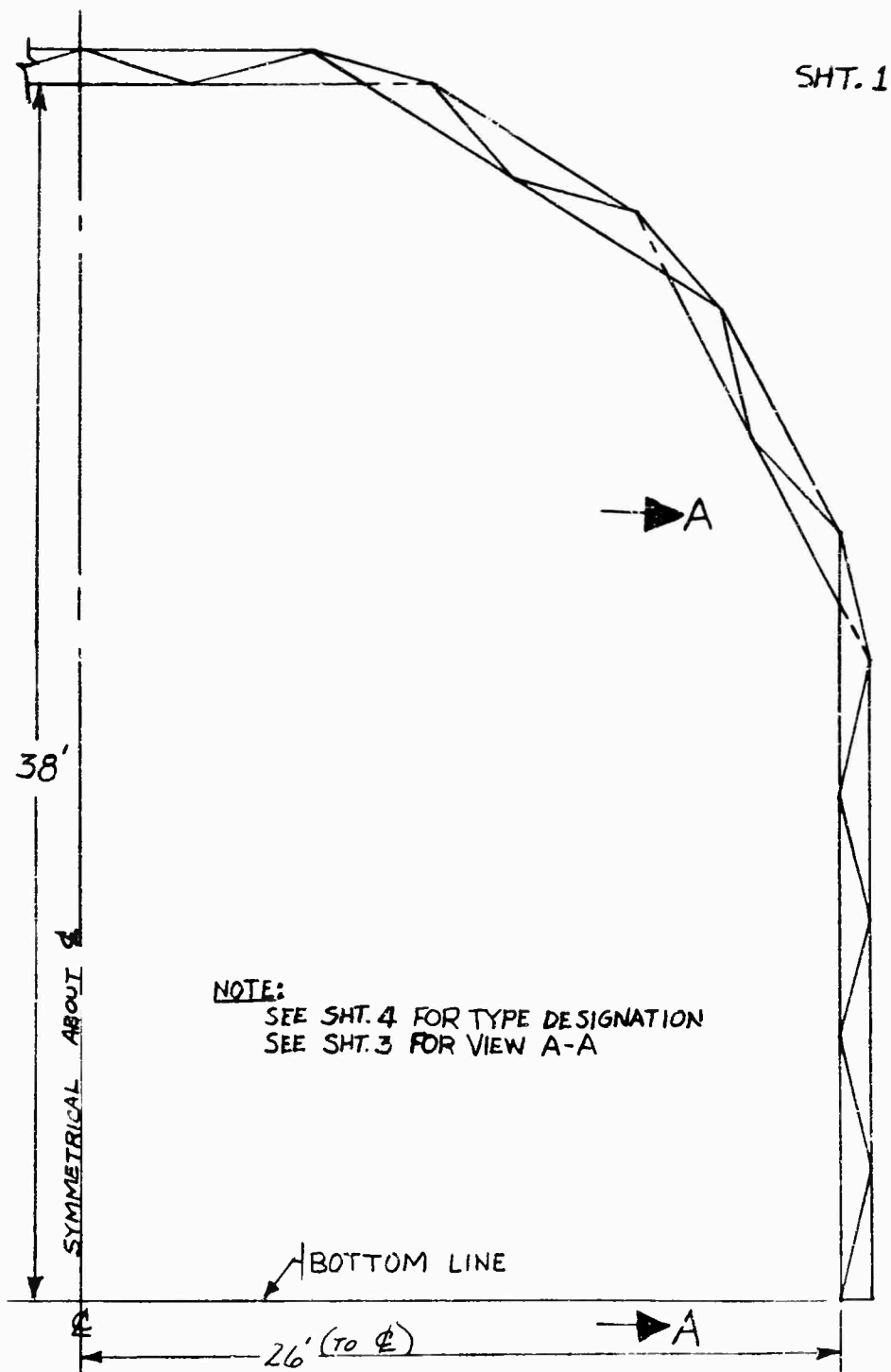

Fig. 47. Strain gage locations -- arch-type building configuration.

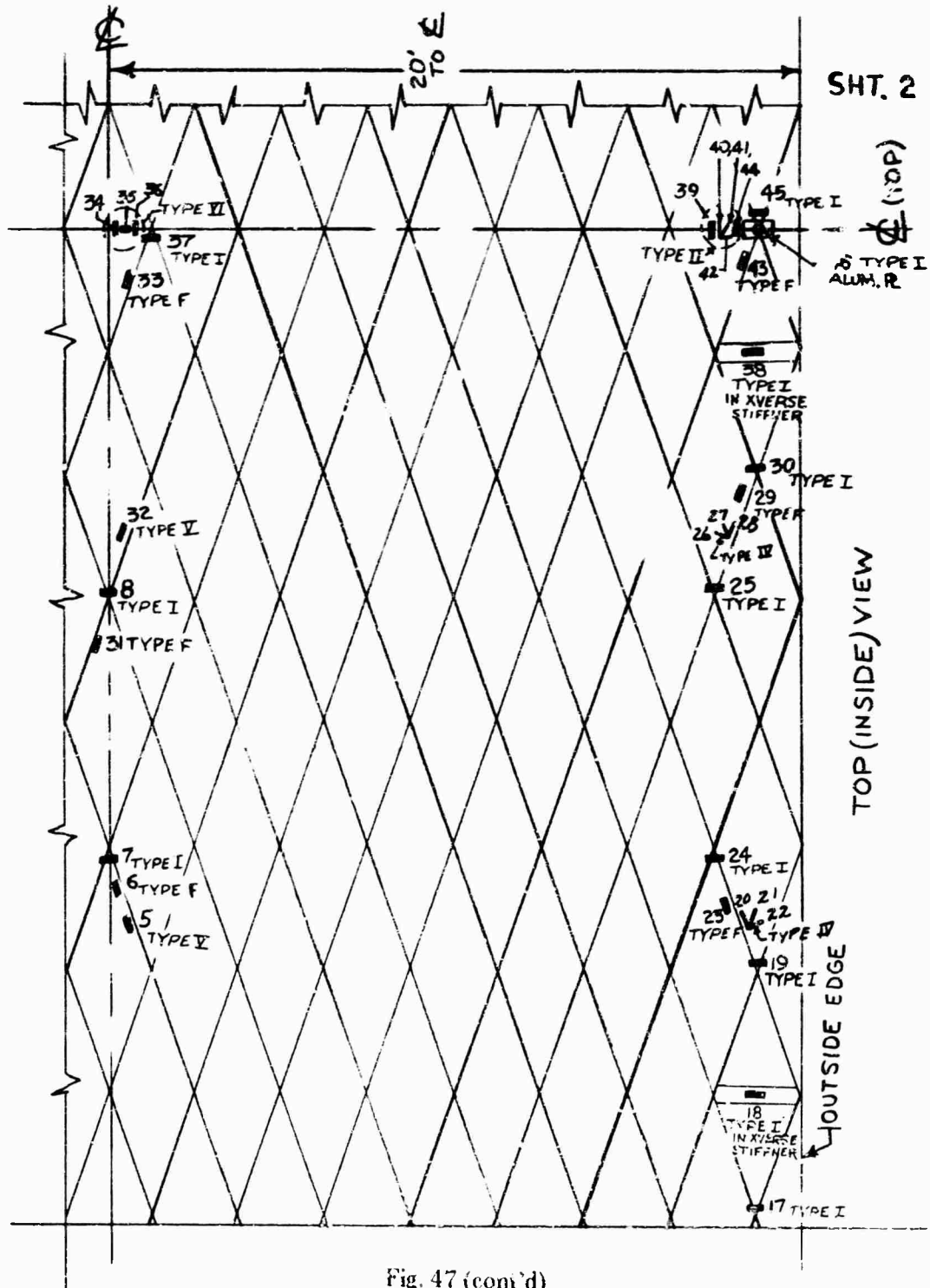
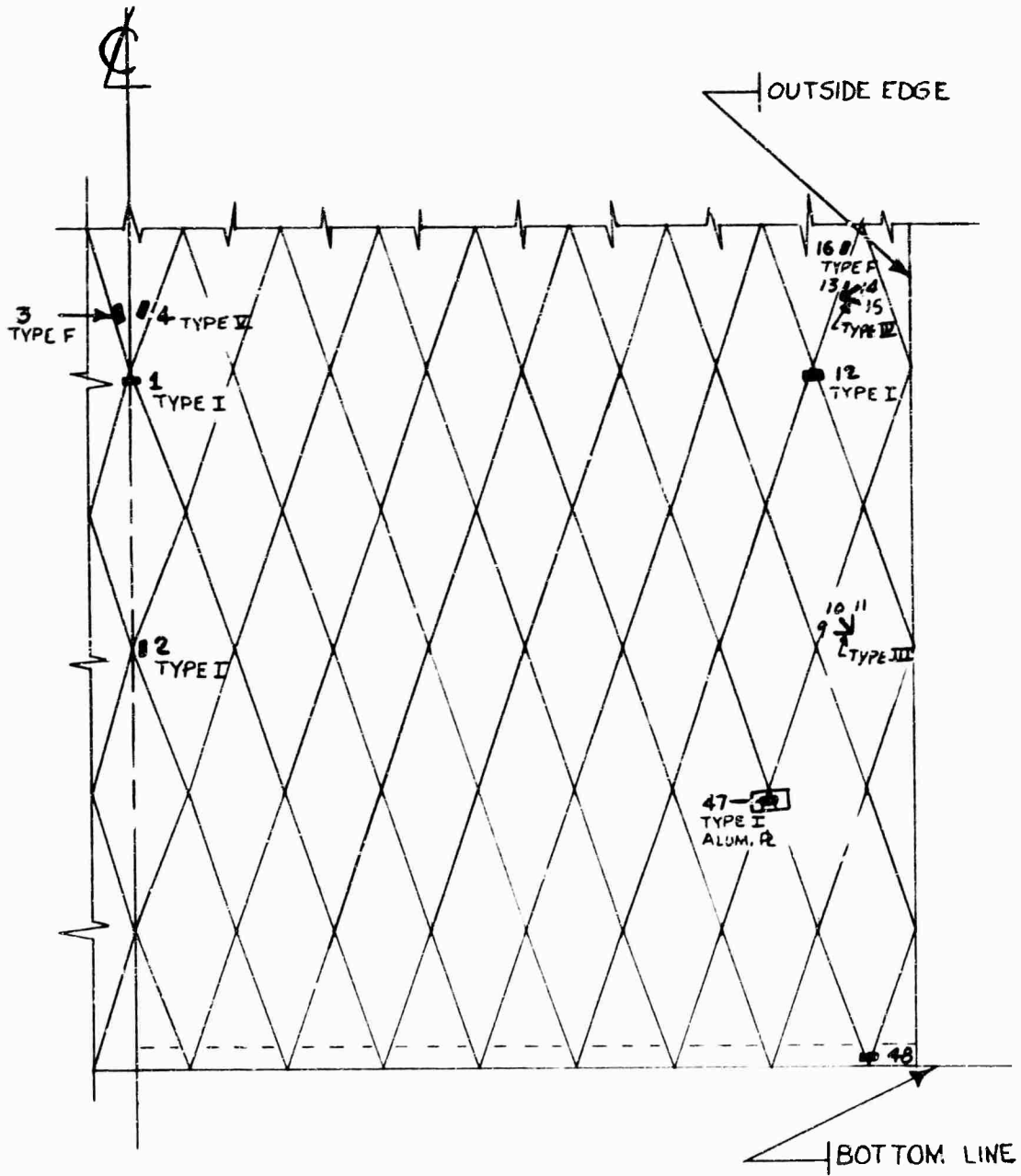

Fig. 47 (cont'd)



SHT. 3



VIEW A-A

Fig. 47 (cont'd)

TYPE DESIGNATION:

1.  - ROSETTE STRAIN GAGE LOCATED AS SHOWN.
 2.  - SINGLE STRAIN GAGE LOCATED AS SHOWN.
1. TYPE I (GROUP) W/ ROSETTE
 2. TYPE II (GROUP) W/ ROSETTE
 3. TYPE III (ROSETTE IN WALL)
 4. TYPE IV (ROSETTE IN ARCH)
 5. TYPE V (SINGLE GAGE)
 6. TYPE F (IN FLANGE ONLY)
 7. TYPE VI (GROUP) W/O ROSETTE

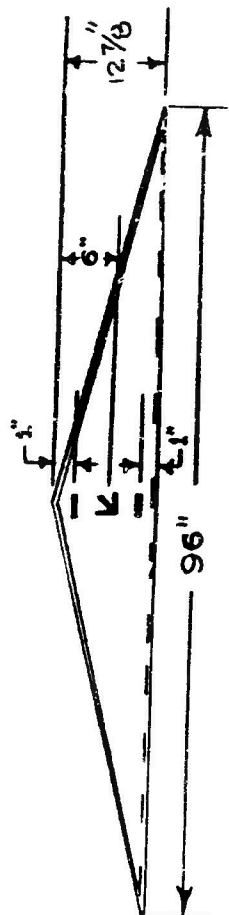
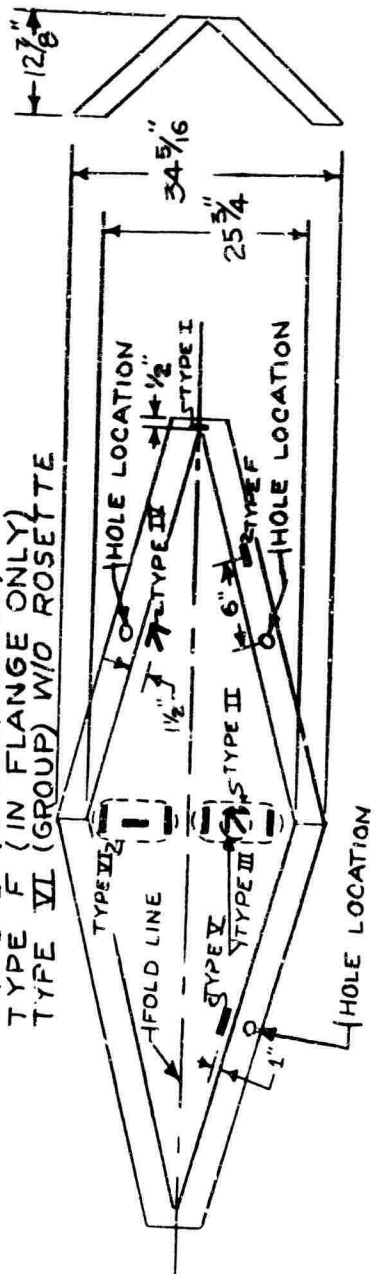
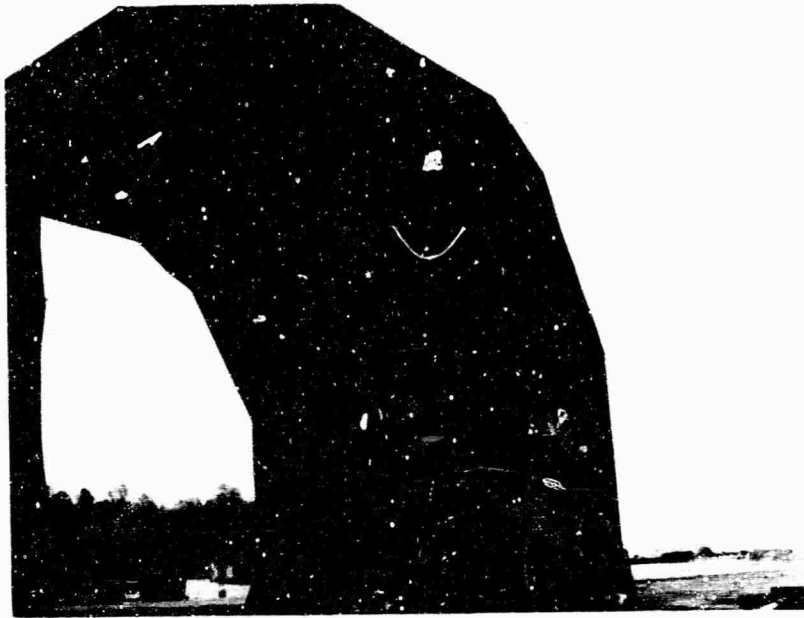

Fig. 47 (cont'd)



S5214

Fig. 48. Strain gage wiring.



S5220

Fig. 49. Strain gage wire harness.

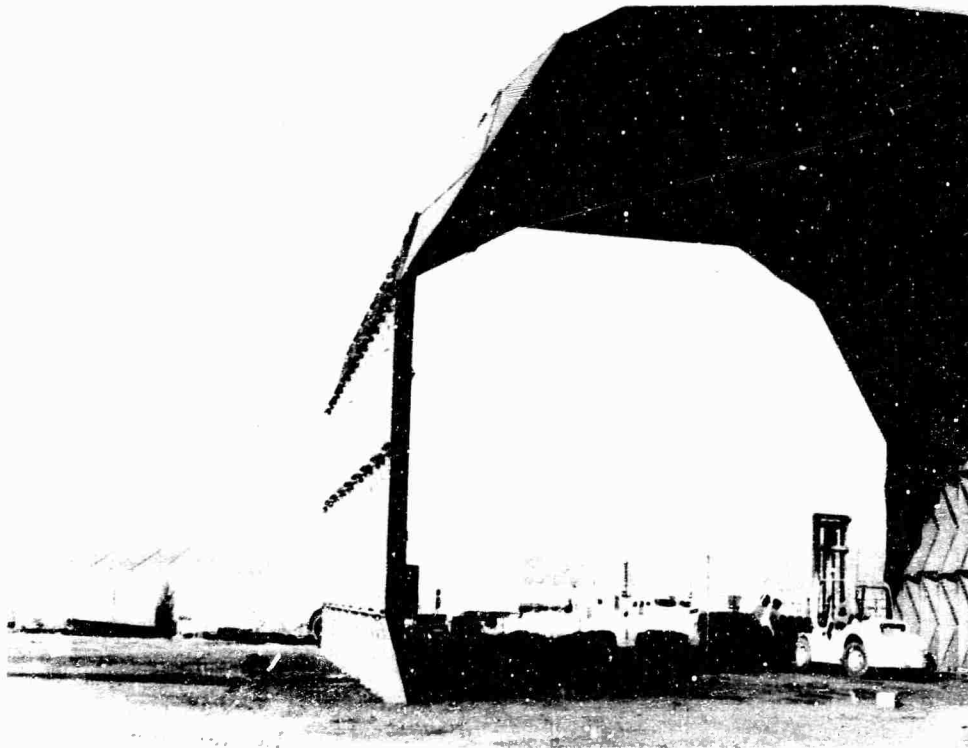

S5688

Fig. 50. Stadia rod installation.

- (e) 20 psf.
- (d) 25 psf.
- (e) 30 psf.
- (f) 31.25 psf.

Each simulated snow load increment was placed in three parts with each part of a load increment placed on the flat center section and then on each slope (Fig. 51).

(2) **Wind Load.** The test wind loading for this building configuration was simulated using aircraft engines with propellers to produce a controlled air velocity. The wind load produced was applied on a vertical wall (Fig. 51). This wall was opposite the wall which was strain-gaged. Four aircraft engines were set up for this wind test. Two of the aircraft engines were mounted on airboats, and

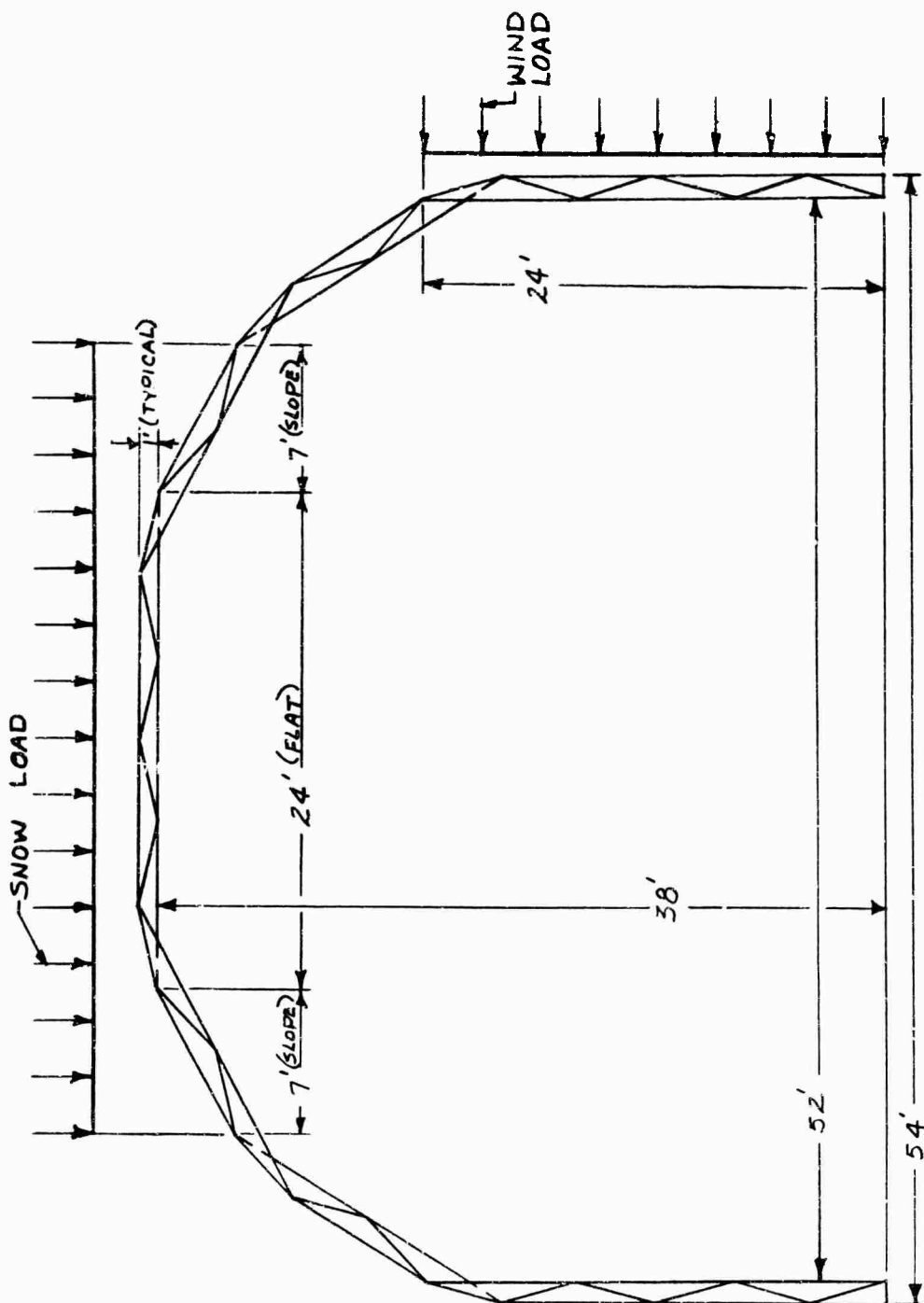
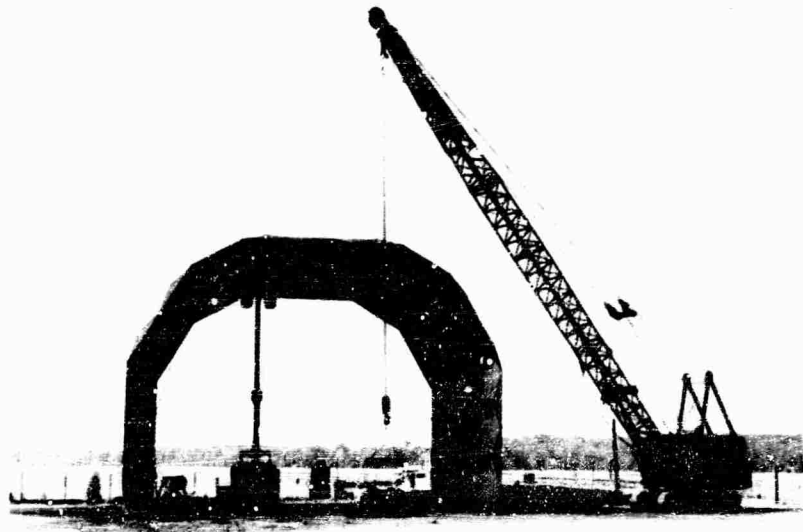
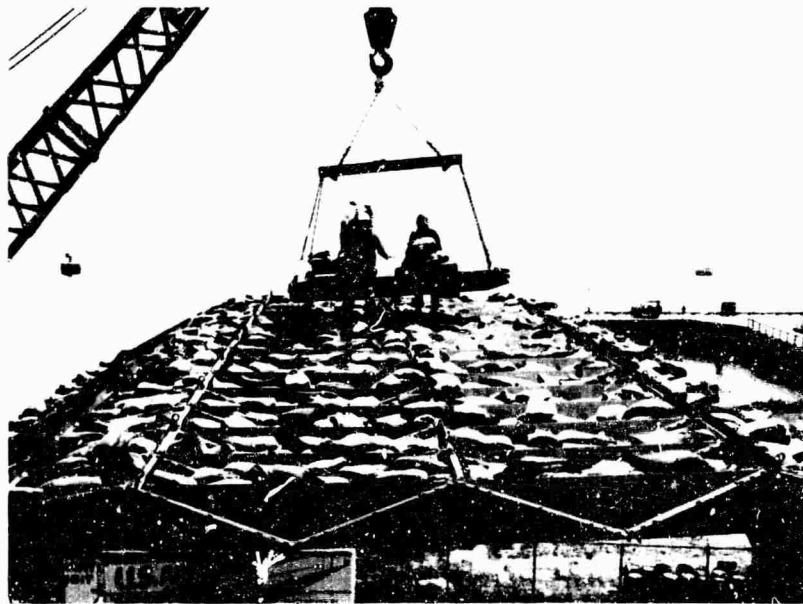

Fig. 51. Arch-type building configuration - test load application area.



S5224

Fig. 52. Method of raising sand and men to roof.



S5673

Fig. 53. Sandbag placement.

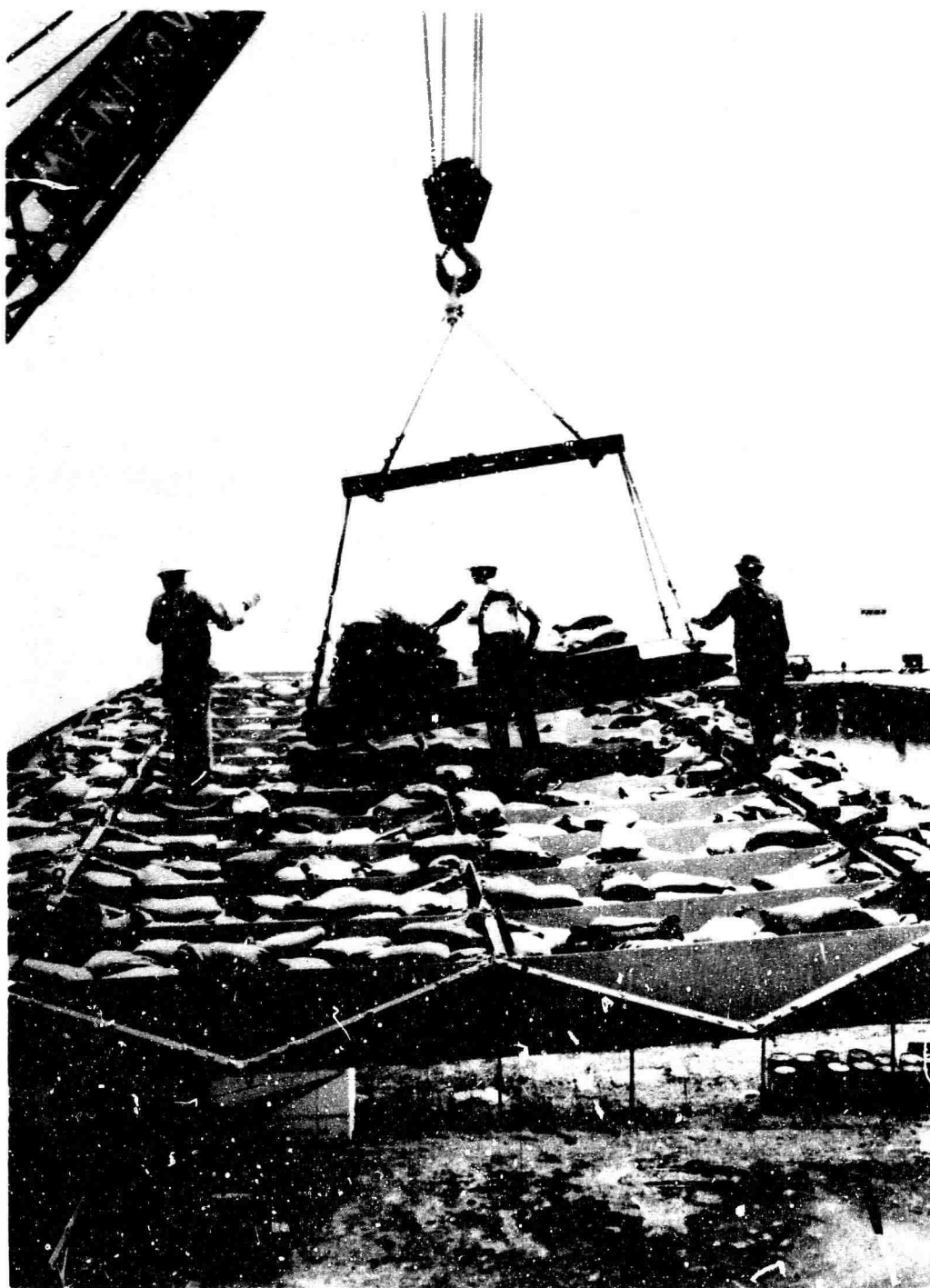

Fig. 54. Movement of pallet for sandbag placement.

S5674

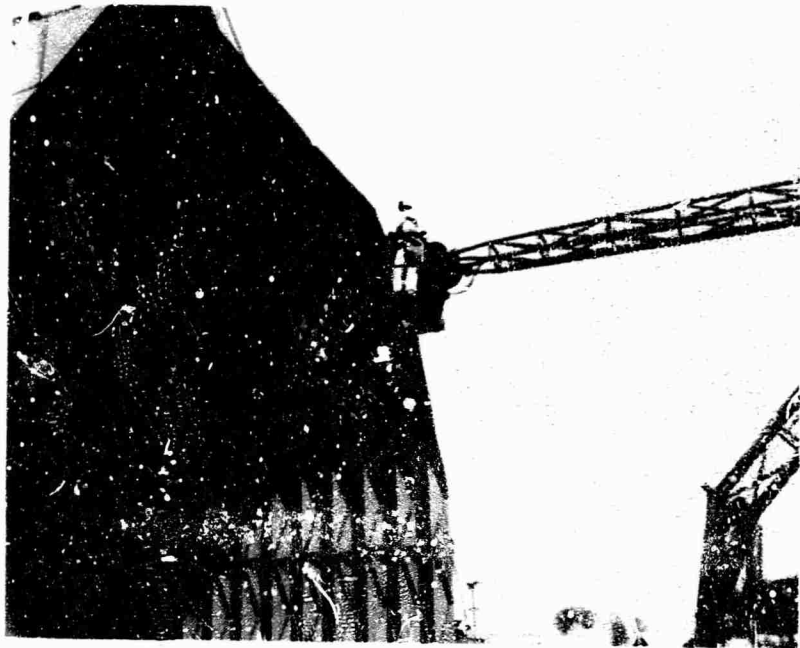

Fig. 55. Equipment carrying men to rooftop.

S5681

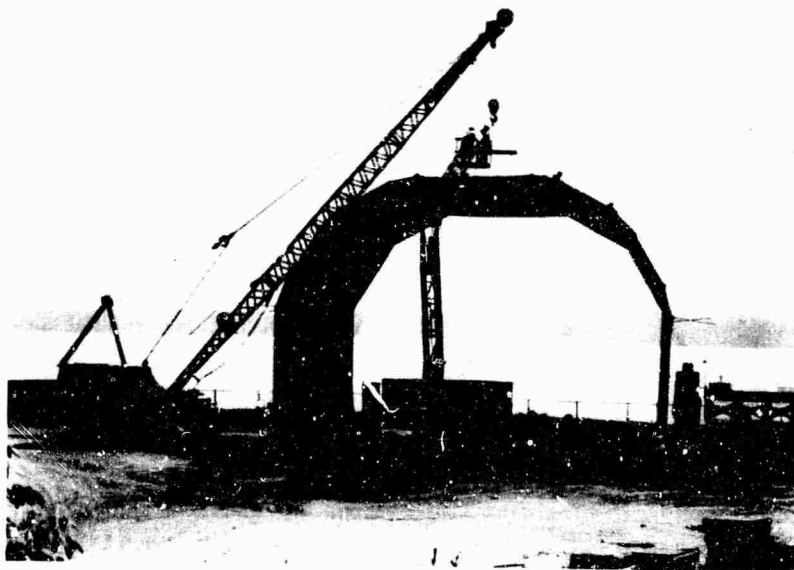

Fig. 56. Test load application.

S5672

the other two aircraft engines were mounted on skids. The propellers were positioned 16 ft from the vertical wall as shown in Figs. 57 through 59. The wind load applied to the building was the measured output of the aircraft engine at 16 ft from the propeller. The wind load increments were applied as follows:

- (a) 50 mph.
- (b) 60 mph.
- (c) 80 mph.
- (d) 100 mph.
- (e) 112 mph.

(3) **Combination Snow Load + Wind Load.** For this combined test load condition, the simulated snow load was applied first followed by application of the wind load. These loads were applied on the areas shown in Fig. 51. The combined snow + wind load was applied in the following increments:

- (a) Snow load = 15 psf.
- (b) Snow + wind load = 15 psf + 60 mph.
- (c) Snow + wind load = 15 psf + 100 mph.
- (d) Snow + wind load = 15 psf + 112 mph.
- (e) Snow load = 25 psf.
- (f) Snow + wind load = 25 psf + 60 mph.

d. **Flat-Roof Building Load Application.** After application of the initial load increment and each successive load increment, strain gage readings, horizontal deflections, and vertical deflections were recorded. Strain gage locations are shown in Fig. 60. Horizontal stadia rods were placed on both walls at a height of 12 ft above ground level at approximately 5 ft from each end. Vertical stadia rods were hung by wires along the span centerline at approximately 2.5 ft from each end and at the center. Roof post tensioning was also considered to eliminate roof sag.

(1) **Snow Load.** The test snow loading for the building configuration was simulated by placing sandbags on the roof area shown in Fig. 61. The sandbags

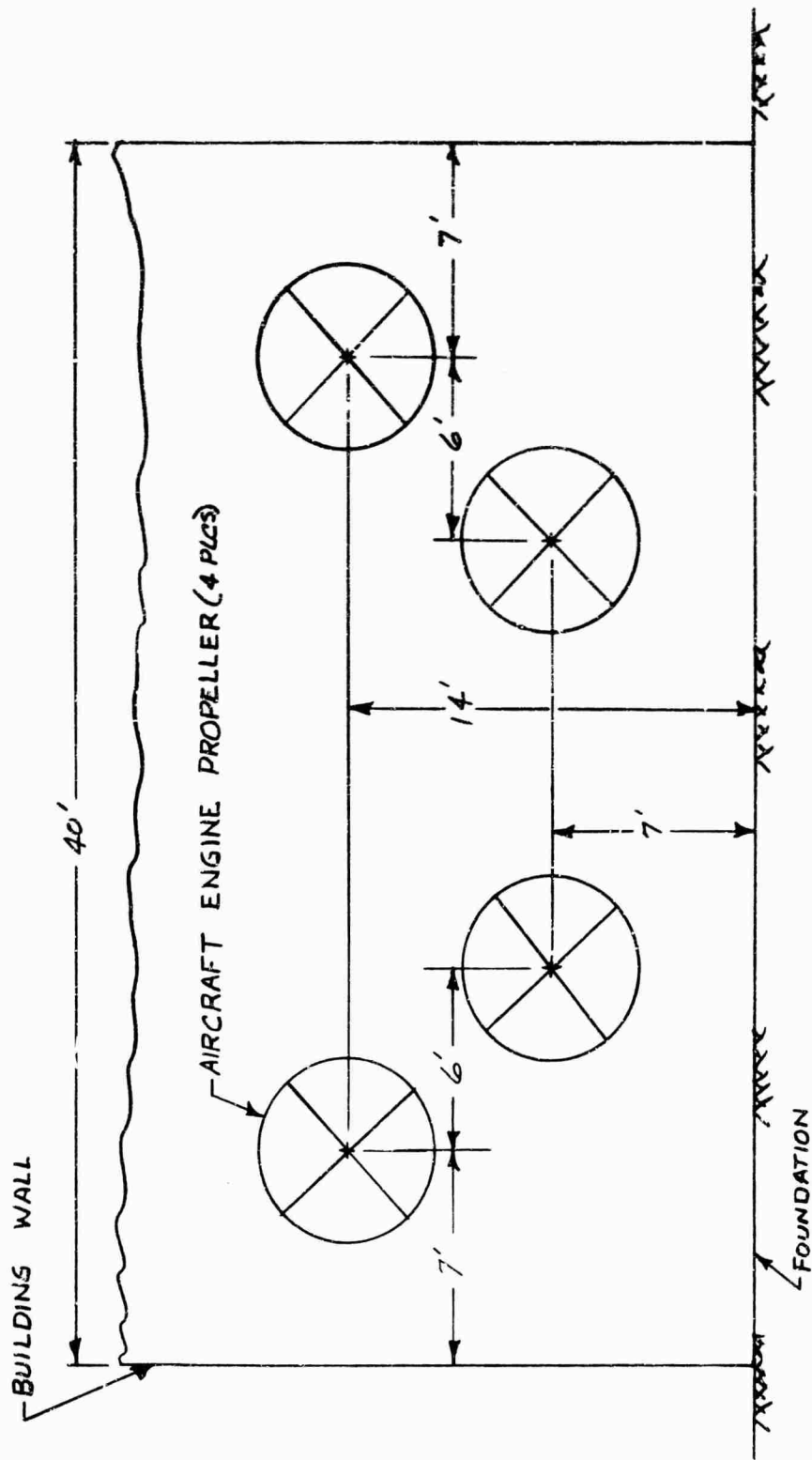
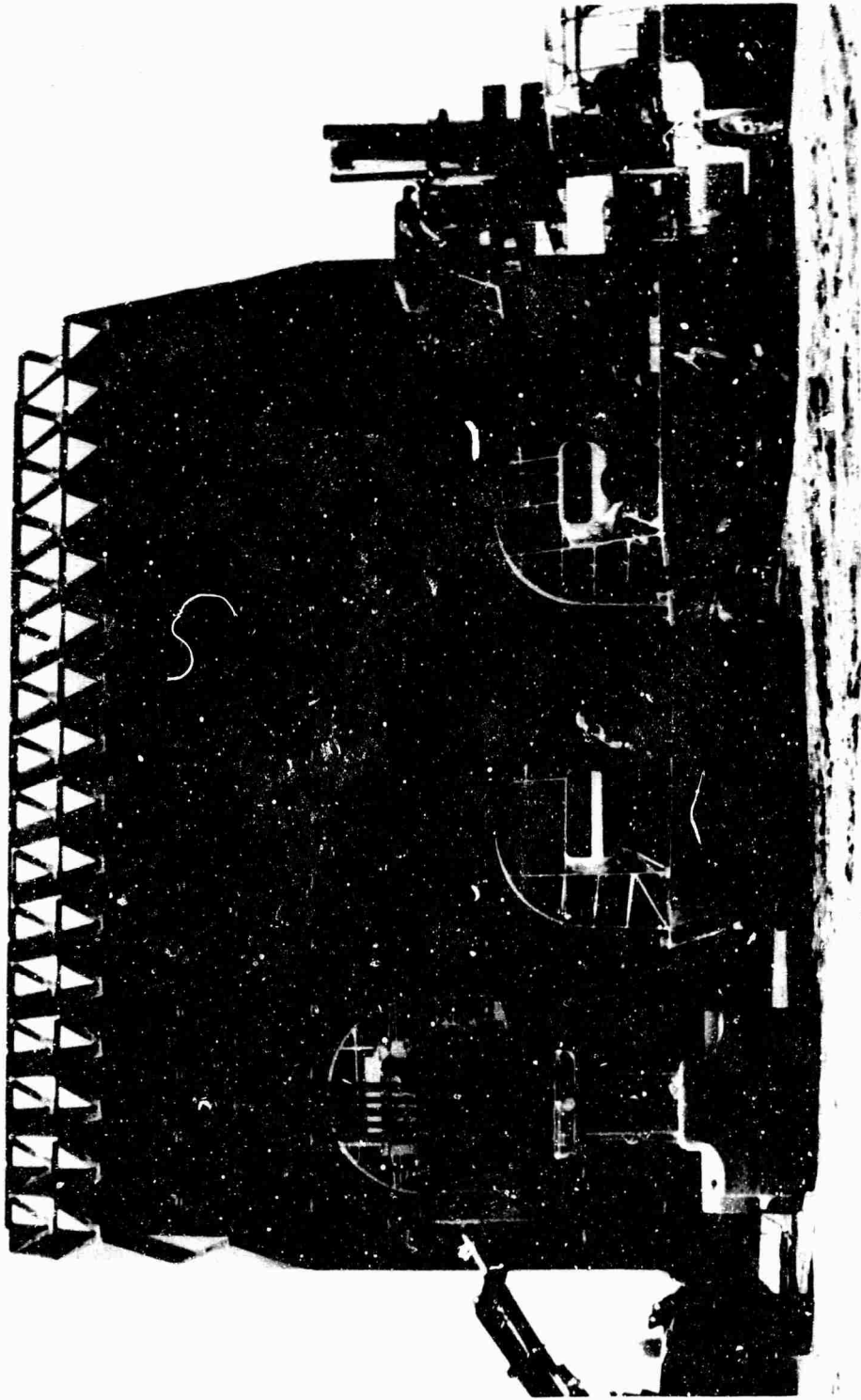
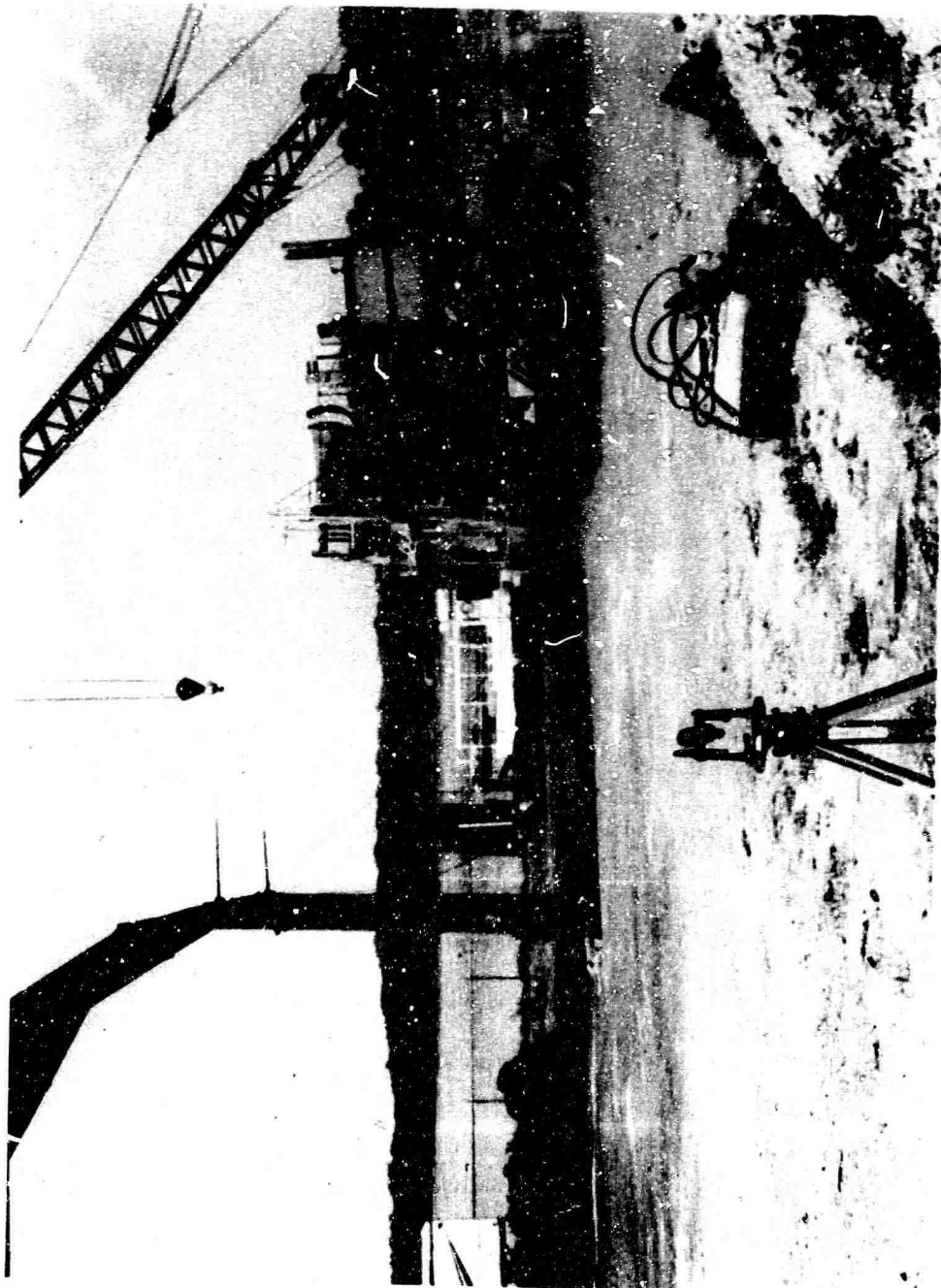

Fig. 57. Aircraft engine location for wind test.



S7584

Fig. 58. Wind test equipment arrangement.



S7533

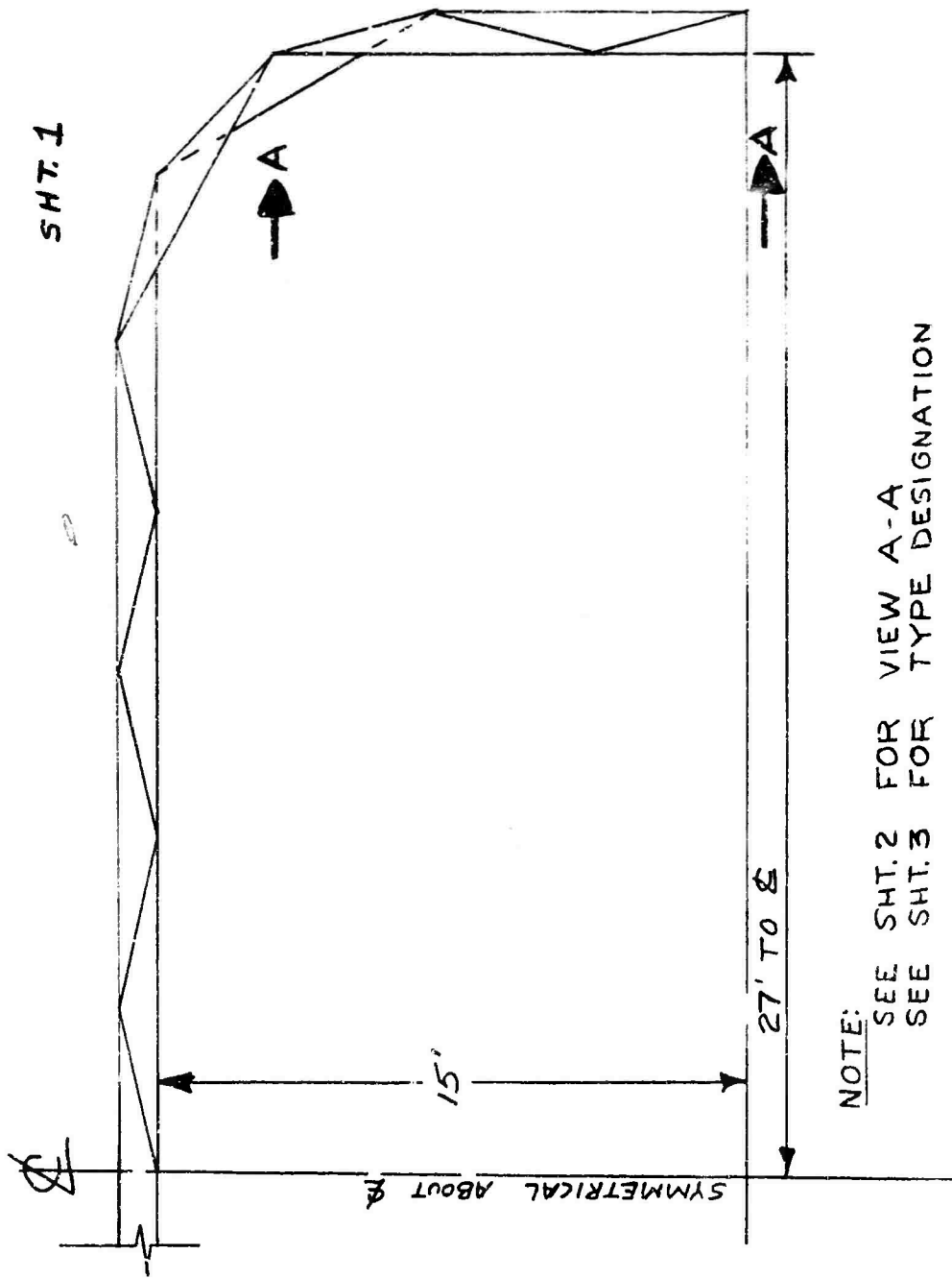

Fig. 59. Wind test load application.



NOTE:
 SEE SHT. 2 FOR VIEW A-A
 SEE SHT. 3 FOR TYPE DESIGNATION

Fig. 60. Strain gage locations - flat-roof building configuration.

TYPE DESIGNATION:

1.  - ROSETTE STRAIN GAGE LOCATED AS SHOWN.
2.  - SINGLE STRAIN GAGE LOCATED AS SHOWN
3. TYPE I (SINGLE GAGE)
4. TYPE II (GROUP) W/ ROSETTE
5. TYPE III (ROSETTE IN WALL)
6. TYPE IV (ROSETTE IN ARCH)
7. TYPE V (SINGLE GAGE)
8. TYPE F (IN FLANGE ONLY)
9. TYPE VI (GROUP) W/O ROSETTE

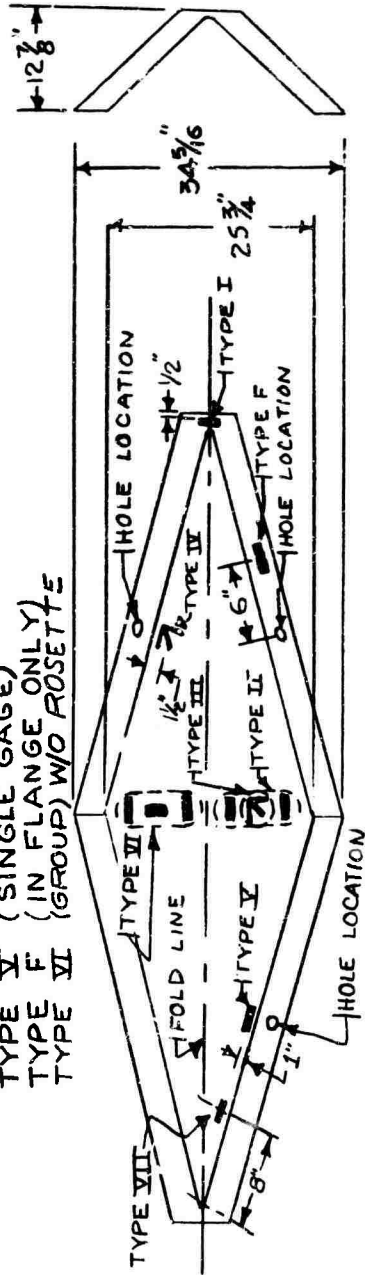

TYPE VII (SINGLE GAGE)

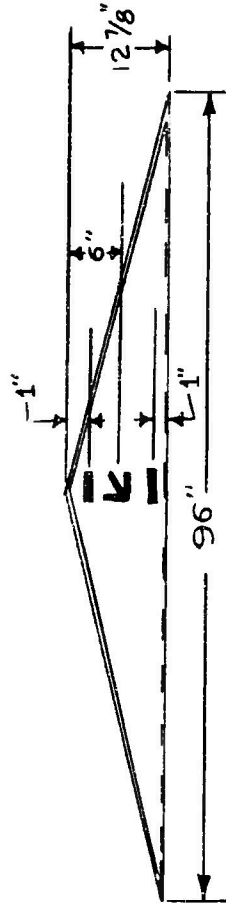

Fig. 60 (cont'd)

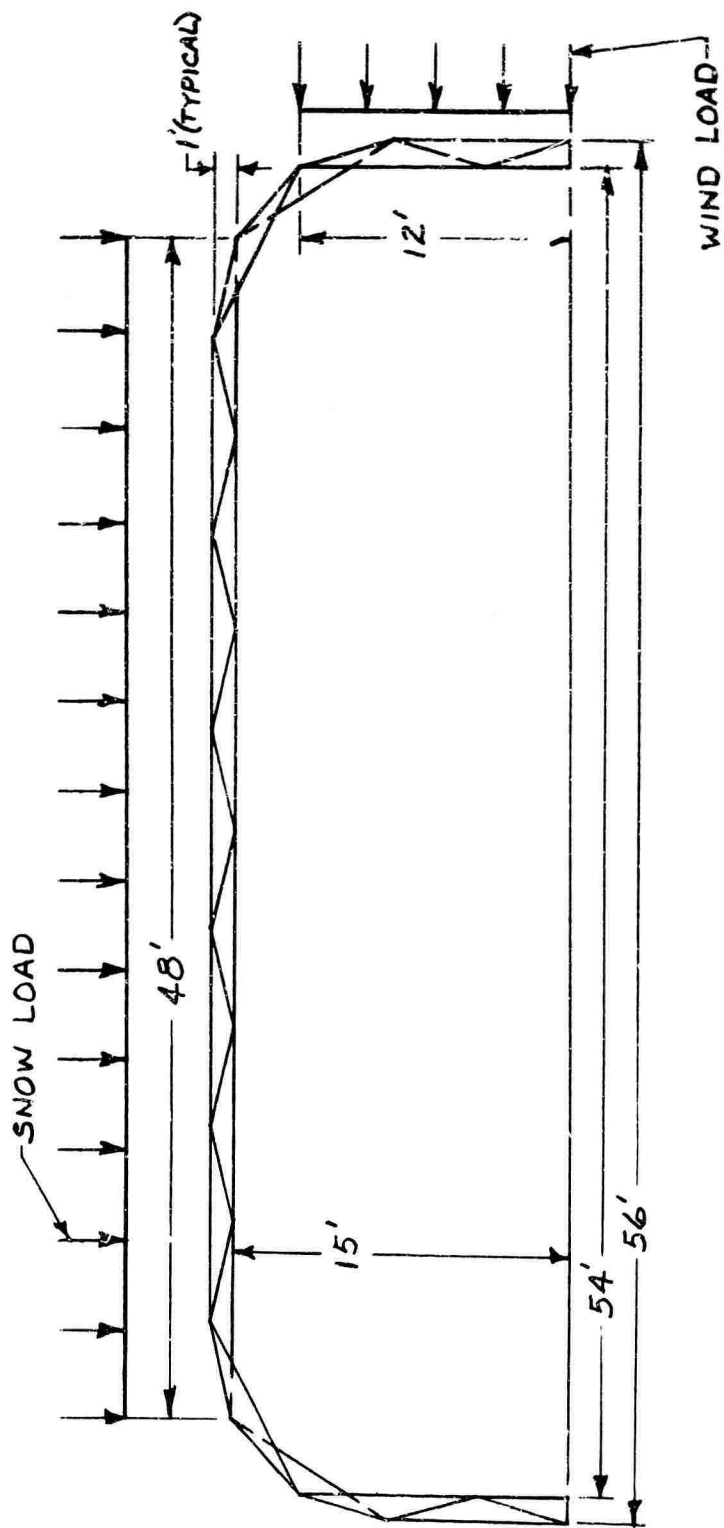

Fig. 61. Flat-roof building configuration -- test load application area.

were weighed, placed on a steel pallet, and raised to the rooftop of the building by a crane. Men distributed the sandbags uniformly over the load area. Portable wooden stairs were used by the men to reach the top of this building. Safety ropes were not used by the men while working on this building. The simulated snow load was applied in the following increments:

- (a) 10 psf.
- (b) 15 psf.
- (c) 25 psf.
- (d) 27.4 psf.*
- (e) 29.9 psf.
- (f) 32.4 psf.

(Note: The asterisk denotes load increment at which the sand weight was 25 psf. The additional 2.4 psf was water weight due to rain. The test load area had been covered with plastic sheets prior to the rain, but the accompanying winds blew some of the plastic off the sandbagged portion (Figs. 62 and 63).)

(2) **Wind Load.** The test wind loading for this building configuration was simulated by using aircraft engines with propellers to produce a controlled air velocity. The wind load produced was applied on a vertical wall (Fig. 61). This wall was opposite the wall which was strain-gaged. Two aircraft engines were set up for this test (Figs. 64 and 65). The propellers were positioned at 16 ft from the vertical wall, 6 ft in from each end of the wall and 7 ft from ground level to center of propeller. The wind load applied to the building was the measured output of the aircraft engine at 16 ft from the propeller. This output was measured prior to wind load application. The wind load increments were applied as follows:

- (a) 50 mph.
- (b) 60 mph.
- (c) 80 mph.
- (d) 100 mph.
- (e) 112 mph.



Fig. 62. Storm effects on loaded roof.

S5802

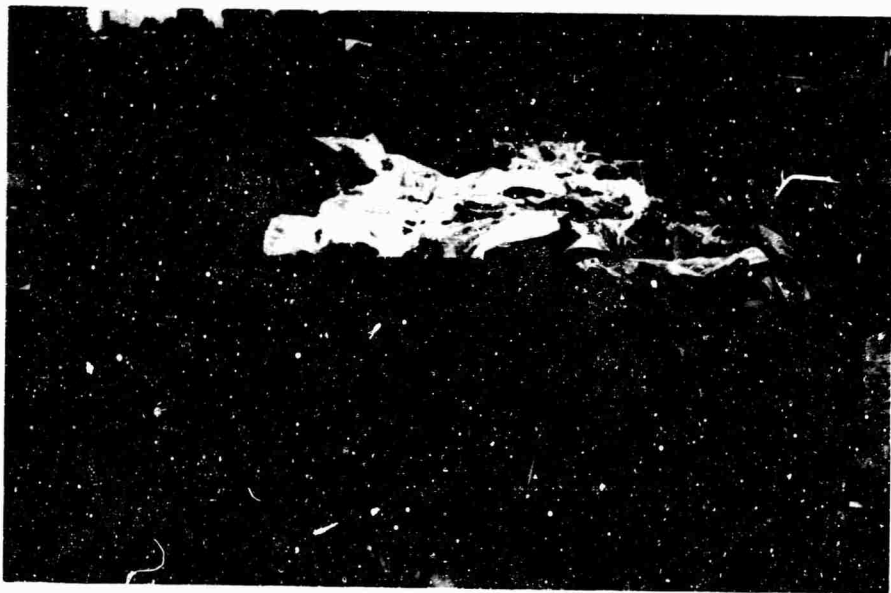
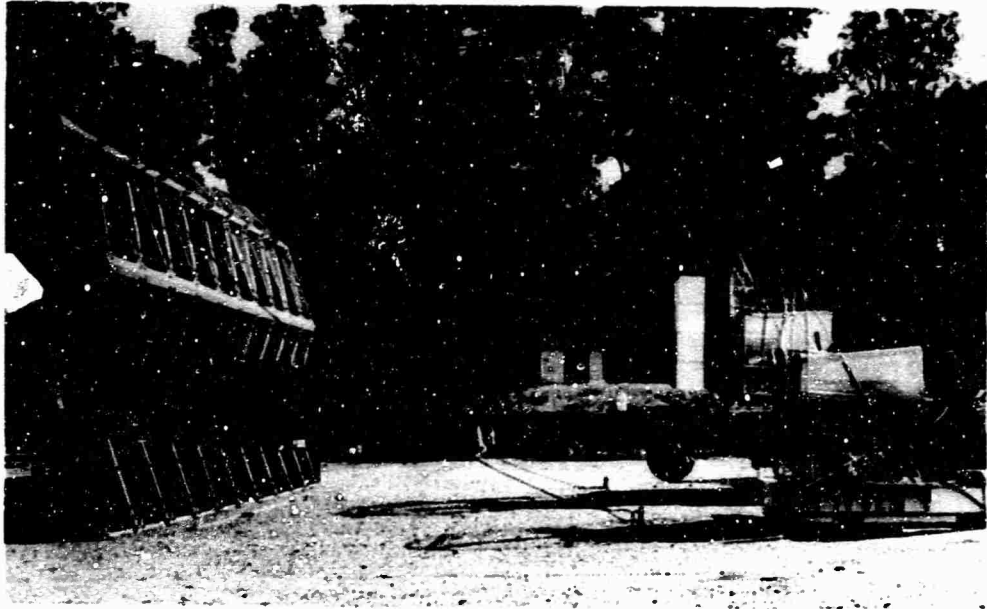

Fig. 63. Storm effects on roof cover.

S5803



S5806

Fig. 64. Wind test equipment setup – side view.

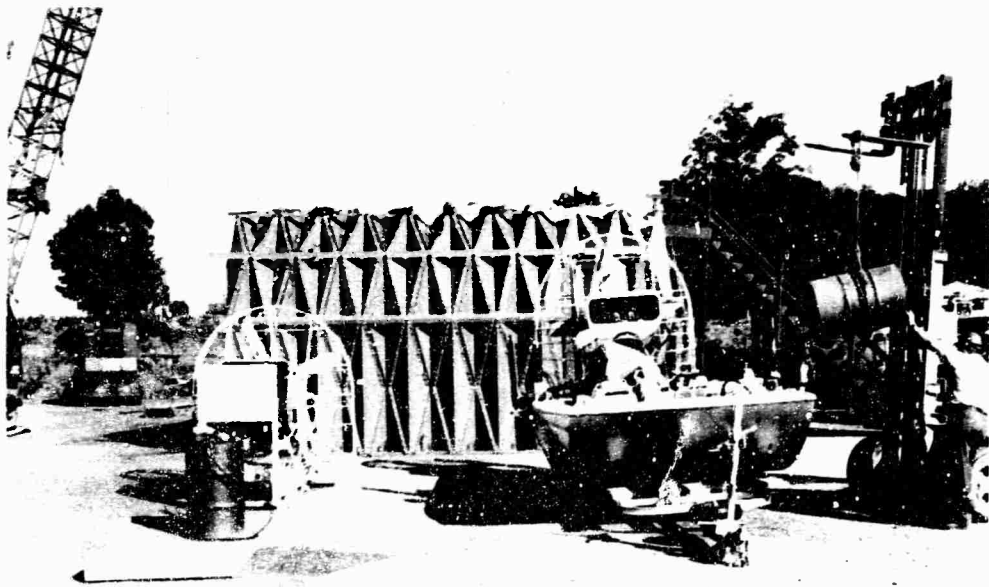

S5804

Fig. 65. Wind test equipment setup – end view.

(3) **Combination Snow Load + Wind Load.** This combined test load condition was performed in conjunction with the snow load test. When the desired simulated snow load increment was applied to the structure, the corresponding wind load was applied. This load condition was applied on the areas shown in Fig. 61. The combined snow and wind load was applied in the following increments.

(a) Snow + wind load = 15 psf + 100 mph.

(b) Snow + wind load = 27.4 psf + 60 mph.

(4) **Post Tensioning.** After completion of design load testing, an attempt was made to post tension the flat-roof building. The purpose of post tensioning was to eliminate roof sag and determine if loads could be increased as post tensioning was increased.

Eyebolts were installed at nodal points and cables were tied across the building span (Fig. 66) for use in post tensioning. Eleven cables were placed as shown, one along each end and one along each inside fold line. Prior to applying tension to any of the cables, the roof sag was removed and a 6-in. camber at span centerline was created by lifting with a crane. The cables were tensioned to 4,000 lb. Tension was measured by a dynamometer placed in each cable.

e. **Test Beam Load Application.** Static loads were applied to the straight and curved test beams. The initial increment of load was increased in increments of 500 lb to 1,000 lb until structural failure occurred. Strain-gage readings and deflections were recorded for each increment of load.

(1) **Straight Beam.** The load on both straight beams was applied 10 ft from one end. A hydraulic jack was used to apply the test load in controlled increments (Fig. 67). Vertical deflections were recorded at the load location.

(2) **Curved Beam.** The load on both curved beams was applied by the use of cable hoists as shown in Figs. 68 and 69. Dynamometers were used to measure the applied load. Vertical deflections were recorded at span centerline. Horizontal deflections were recorded between points of load application.

7. **Test Results.** The test loads were applied to the arch-type building configuration and the flat-roof building configuration with no apparent structural failure. The test-beam configurations were loaded until structural failure occurred. The stresses, deflections, and any other pertinent items noted during the test were recorded.

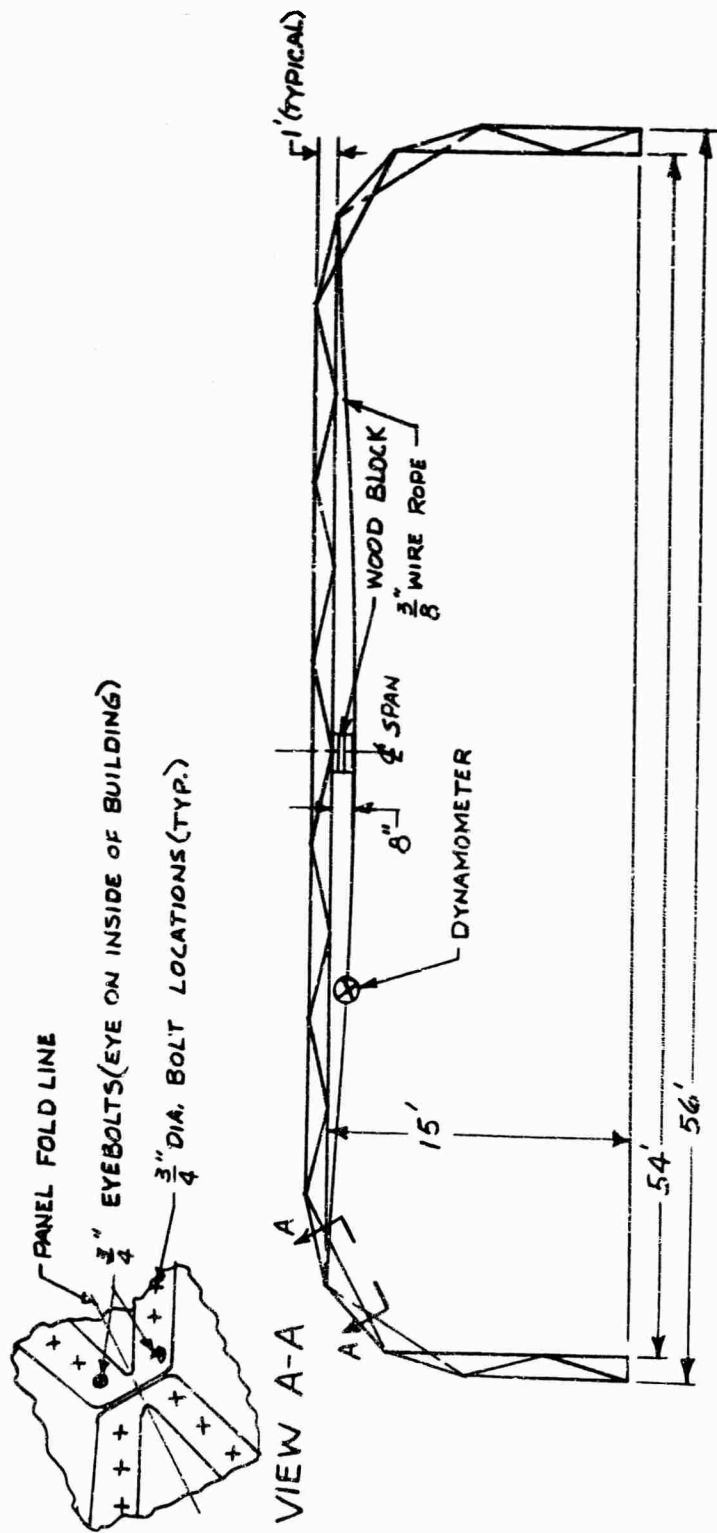
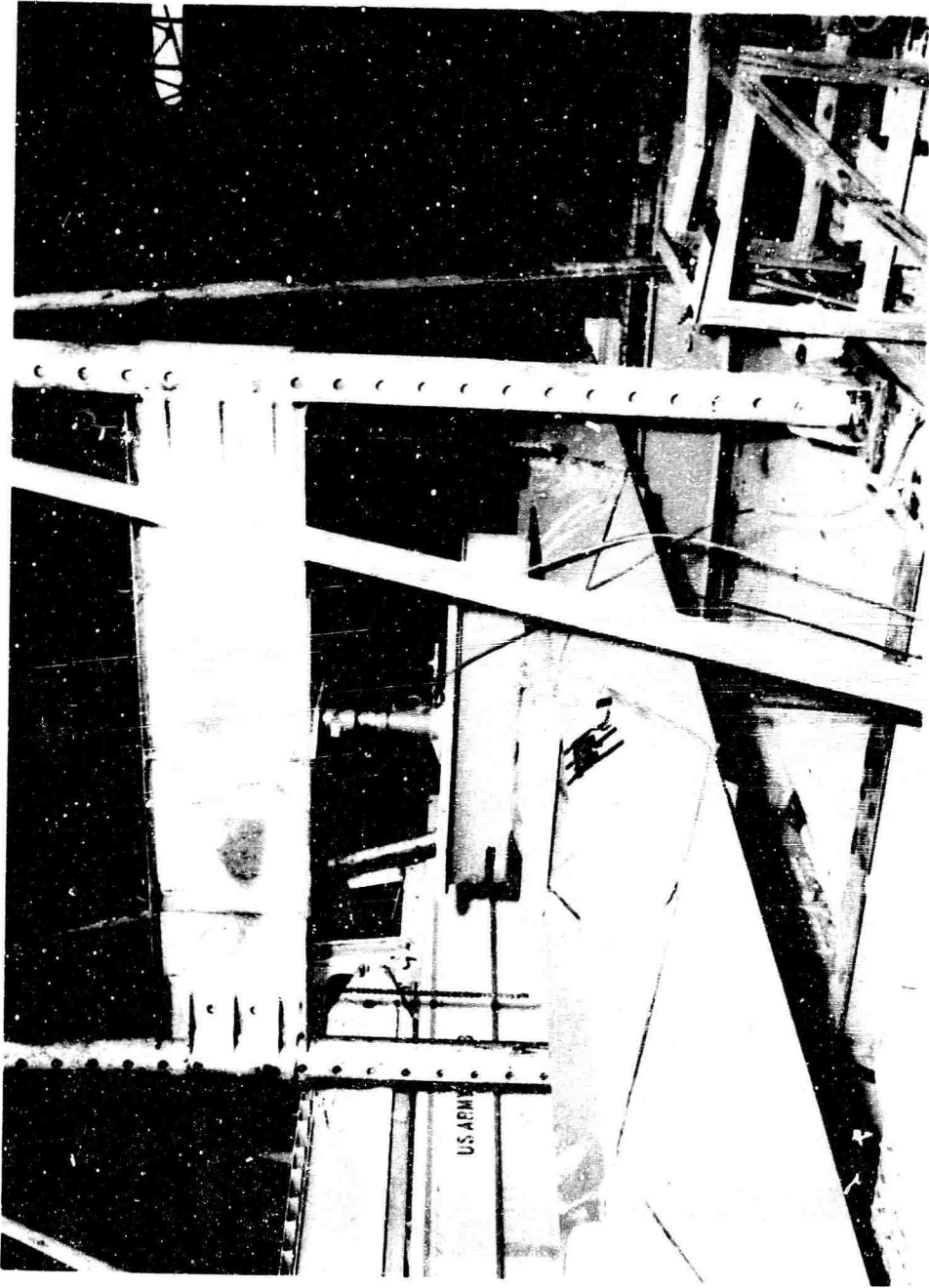
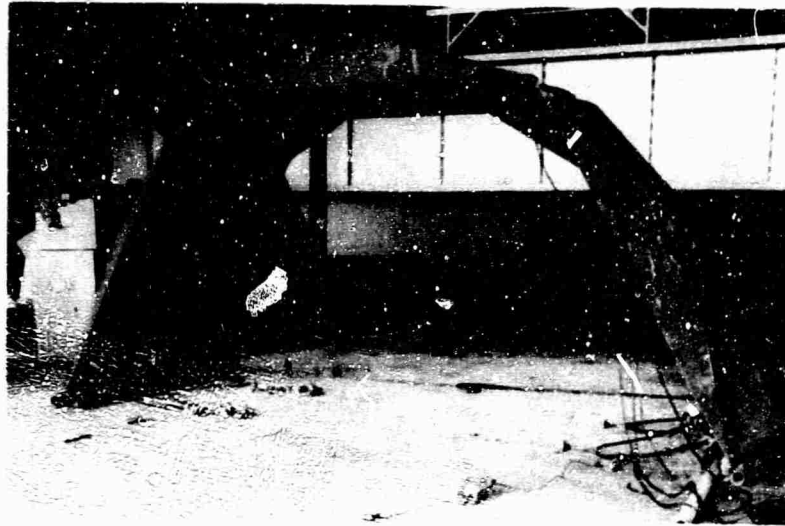

Fig. 66. Flat-roof building configuration post tension setup.



S3617

Fig. 67. Straight beam test setup.



S3595

Fig. 68. Curved beam (without stiffeners) test setup.

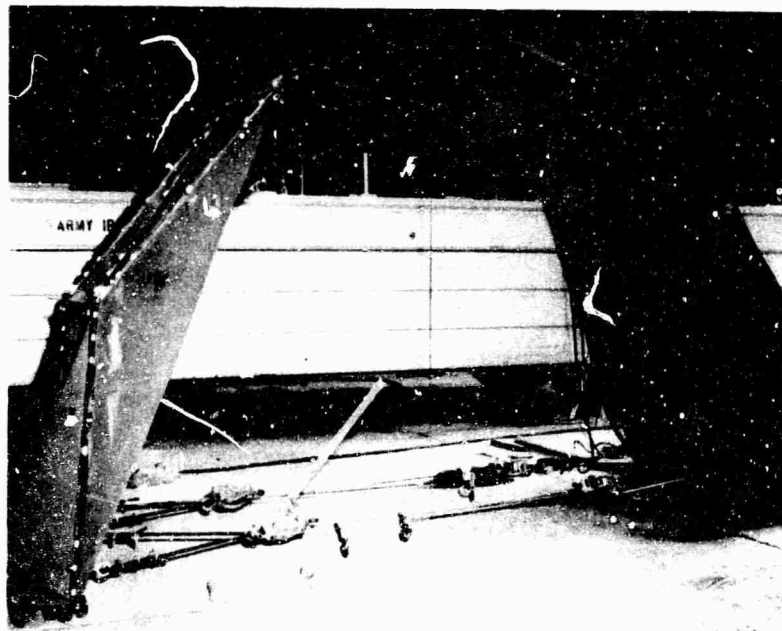

S3598

Fig. 69. Curved beam (with stiffeners) test setup.

a. **Arch-Type Building.** The stresses and corresponding deflections recorded during application of each test load are as follows:

(1) **Snow Load.**

(a) Stress—Table I.

(b) Deflection—Table II.

(2) **Wind Load.**

(a) Stress—Table III.

(b) Deflection—Table IV.

(3) **Combined Snow + Wind Load.**

(a) Stress—Table V.

(b) Deflection—Table VI.

b. **Flat-Roof Building.** The stresses and corresponding deflections recorded during application of each structural test load are as follows:

(1) **Snow Load.**

(a) Stress—Table VII.

(b) Deflection—Table VIII.

(2) **Wind Load.**

(a) Stress—Table IX.

(b) Deflection—Table X.

(3) **Combined Snow + Wind Load.**

(a) Stress—Table XI.

(b) Deflection—Table XII.

Table I. Simulated Snow Load Stresses – Arch-Type Structure

Strain Gage No.	Stresses (ksi) at Load (psf)					
	10 psf	15 psi	20 psf	25 psf	30 psf	31.25 psf
1	—	—	—	—	—	—
2	0	0.8	0.3	-0.3	-2.1	-3.3
3	0.3	-0.3	-1.2	-1.5	-2.4	-3.3
4	0.9	0.4	-0.2	-0.2	-1.7	-2.3
5	-0.3	-2.4	-3.0	-3.6	-5.7	-7.2
6	0	-0.3	-2.0	-2.9	-4.1	-5.3
7	1.8	2.4	1.0	2.2	2.5	2.6
8	0	-0.5	-0.8	-0.5	-5.0	-7.4
9	-2.4	-4.8	-6.5	-9.2	-11.6	-12.8
10	-2.7	-5.3	-6.8	-9.5	-11.3	-12.5
11	1.2	0.6	-1.5	-3.3	-4.5	-5.4
12	1.5	0.6	0.6	4.5	9.0	9.9
13	-2.4	-5.4	-7.2	-9.6	-11.1	-12.3
14	1.8	1.8	-0.3	-3.0	-4.5	-5.7
15	-0.6	-2.9	-5.9	-9.2	-11.6	-12.8
16	0	2.4	0.4	-1.4	-3.2	-4.1
17	2.1	2.1	-2.7	-7.8	-9.3	-9.0
18	-1.2	-3.3	-5.7	-7.8	-10.5	-11.7
19	1.2	9.0	13.1	17.0	16.7	16.4
20	-17.4	-18.3	-27.3	-34.4	-37.1	-38.3
21	-2.1	-5.4	-7.8	-9.9	-11.7	-12.9
22	-1.8	-4.5	-6.9	-8.7	-10.2	-11.4
23	0.3	0.6	-0.6	-1.8	-3.9	-5.4
24	1.5	0.6	-0.8	-1.4	0.1	-0.2
25	0	0	1.1	3.2	3.8	3.5
26	0.6	0.9	0	0	-2.1	-2.7
27	-0.6	-3.5	-5.0	-5.6	-8.3	-9.5
28	-0.3	-3.3	-5.1	-6.6	-9.9	-11.4
29	-2.4	-5.1	-8.0	-9.9	-12.8	-14.6
30	0	2.1	-7.1	-9.2	-10.1	-10.4
31	-1.5	-4.2	-5.4	-7.2	-10.8	-12.3
32	0.3	-1.5	-2.6	-3.5	-6.2	-7.7
33	0	-1.4	-1.9	-2.2	-4.9	-6.4
34	0	-2.0	0.6	1.8	1.5	0.9
35	-1.2	-1.5	-1.3	-0.7	-2.6	-4.1

Table I (cont'd)

Strain Gage No.	Stresses (ksi) at Load (psf)					
	10 psf	15 psi	20 psf	25 psf	30 psf	31.25 psf
36	0	-1.7	-2.5	-3.1	-6.1	-7.9
37	0.3	-0.9	-2.9	-4.7	-9.8	-12.8
38	-0.3	-3.5	-3.3	-2.4	-5.2	-6.4
39	2.1	3.0	4.2	6.3	-5.7	5.1
40	0	-2.7	-4.5	-3.9	-6.3	-7.2
41	0.6	1.1	0	0.6	-1.8	-3.0
42	0	-3.0	-4.5	-4.8	-7.2	-8.4
43	-1.5	-4.8	-6.8	-7.4	-10.4	-11.6
44	-0.3	-4.1	-5.3	-5.3	-8.0	-9.2
45	0.9	1.2	2.5	4.7	2.6	1.7
46	2.7	4.1	5.6	7.9	9.3	10.1
47	0.1	-0.5	-1.6	-2.9	-3.7	4.0
48	-3.0	-5.3	-8.5	-11.8	-14.8	-16.0

Table II. Simulated Snow Load Deflections -- Arch-Type Structure

Applied Load (psf)	Loc. of Inst.	Horizontal Deflections						Vertical Deflections					
		Near		Center		Far		Near		Center		Far	
		Orig. Dim. (ft)	Δb (ft)	Orig. Dim. (ft)	Δb (ft)	Orig. Dim. (ft)	Δb (ft)	Orig. Dim. (ft)	Δb (ft)	Orig. Dim. (ft)	Δb (ft)	Orig. Dim. (ft)	Δb (ft)
0	E	10.03	0	9.80	0	3.09	0	5.59	0	7.84	0	4.69	0
	W												
10	E	10.00	0.03	9.76	0.04	3.14	0.05	5.64	0.05	7.80	0.04	4.78	0.09
	W												
15 ^(a)	E	9.93	0.10	9.70	0.10	3.20	0.11	5.75	0.16	7.65	0.19	4.91	0.22
	W			8.05	0	3.05	0						
15	E	9.90	0.13	9.66	0.14	3.24	0.15	5.75	0.16	7.65	0.19	4.91	0.22
	W			8.05	0	3.05	0						
20	E	9.84	0.19	9.59	0.21	3.28	0.19	5.83	0.24	7.57	0.27	5.00	0.31
	W			7.99	0.06	2.98	0.07						
25	E	9.76	0.27	9.53	0.27	3.36	0.27	5.87	0.28	7.51	0.33	5.06	0.37
	W			7.96	0.09	2.94	0.11						
30	E	9.73	0.30	9.50	0.30	3.40	0.31	5.97	0.38	7.39	0.45	5.17	0.48
	W			7.84	0.21	2.84	0.21						
31.25	E	9.70	0.33	9.48	0.32 ^(b)	3.42	0.33	6.04	0.45	7.34	0.50	5.23	0.54
	W			7.82	0.23 ^(b)	2.81	0.24 ^(b)						
31.25	E	9.70	0.33	9.48	0.32	3.44	0.35	6.08	0.49	7.32	0.52	5.23	0.54
	W			7.77	0.28	2.77	0.28						
0	E	9.93	0.10	9.89	0.09 ^(c)	3.20	0.11 ^(c)	5.64	0.05	7.75	0.09	4.84	0.15
	W			8.08	-0.03 ^(c)	3.07	-0.02 ^(c)						

a. 21 May 1969

b. 22 May 1969

c. 23 May 1969

- (a) Horizontal deflections not taken from west transit location prior to this load increment.
- (b) Not total deflection due to readings being initiated at load of 21,380 lb. Estimated deflection for total load is 0.34 ft at center and 0.34 ft at far side.
- (c) Readings do not indicate return to original position since readings were started at load of 21,380 lb. Estimated final deflection readings are 0.07 ft at center and 0.08 ft at far side.

Table III. Simulated Wind Load Stresses – Arch-Type Structure

Strain Gage No.	Stresses (ksi) at Load (psf)				
	50 mph	60 mph	80 mph	100 mph	112 mph
1	-0.2	-0.2	-1.4	-1.4	-2.0
2	0.2	0	0	0	0.3
3	0	0	0	0.3	0.3
4	-0.3	0	0	0	0.3
5	-0.5	-0.5	-0.5	-0.2	-0.2
6	0	0	0	0	0
7	-0.2	0.2	0.2	0.2	0.5
8	0.6	0.9	0.6	0.3	0.6
9	0.2	0.2	0.2	-0.2	-0.2
10	-0.2	-0.2	-0.2	-0.2	-0.5
11	0	0	0	0	0.3
12	0.2	0.2	0.2	0.2	0.2
13	0.2	0.2	0.2	0.5	0.5
14	-0.2	0.2	0.2	-0.2	-0.2
15	-0.2	-0.2	-0.2	-0.5	-0.5
16	-0.2	0.2	0.2	0.5	0.5
17	1.2	1.1	-0.2	-0.2	0.2
18	-0.2	-0.2	-0.2	-0.2	-0.2
19	0.2	0.2	0.2	0.5	1.1
20	-0.2	-0.2	0.2	-0.2	-0.2
21	0	0	0	0	0
22	0	0	0	0	0
23	0	0.3	0.3	0.3	0.3
24	0.2	0.5	0.8	0.8	1.7
25	-0.2	0.2	-0.2	-0.2	-0.5
26	-0.2	0.2	0.2	0.2	0.5
27	0	0	0.3	0.3	0.3
28	0.2	0.2	0.5	0.5	0.8
29	0	0.6	0.6	0.6	0.6
30	0	0.3	-1.5	-1.5	-1.2
31	0.2	0.2	0.2	0.2	0.5
32	0	0.3	0.3	0.3	0.6
33	-0.5	0.2	0.2	-0.2	-0.2
34	-0.3	0	0	0	0
35	-0.2	-0.2	-0.2	-0.2	0.2
36	-0.3	0	0	-0.3	0
37	-1.2	-0.9	-0.9	-0.9	-0.6

Table III (cont'd)

Strain Gage No.	Stresses (ksi) at Load (psf)				
	50 mph	60 mph	80 mph	100 mph	112 mph
38	-0.8	-0.5	-0.5	-0.8	-0.5
39	-0.6	0	0	0	0.3
40	-0.5	0.2	0.2	0.2	0.5
41	-0.6	0	0	0	0
42	-0.6	0	0	0	0.3
43	-0.6	0	0	0	0
44	-0.5	-0.2	-0.2	-0.2	0.2
45	-0.5	-0.2	-0.2	-0.2	0.2
46	-0.3	-0.3	-0.3	-0.3	0
47	0	0	0	-0.3	-0.3
48	0	0	0	0.3	0.6

Table IV. Simulated Wind Load Deflections -- Arch-Type Structure

Applied Load (mph)	Loc. of Inst.	Horizontal Deflections						Vertical Deflections									
		Near		Center		Far		Near		Center		Far					
		Orig. Dim. (ft)	Δb (ft)	Orig. Dim. (ft)	Δb (ft)	Orig. Dim. (ft)	Δb (ft)	Orig. Dim. (ft)	Δb (ft)	Orig. Dim. (ft)	Δb (ft)	Orig. Dim. (ft)	Δb (ft)				
0	E	4.55	0			9.40	0										
	W	10.50	0			2.60	0	1.08	0						5.17	0	
50	E	4.55	9			9.39	0.01										
	W	10.52	0.02			2.59	0.01	1.08	0						5.17	0	
60	E	4.55	0			9.39	0.01										
	W	10.52	0.02			2.55	0.05	1.08	0						5.17	0	
80	E	4.53	0.02			9.38	0.02										
	W	10.53	0.03			2.54	0.06	1.08	0						5.17	0	
100	E	4.52	0.03			9.36	0.04										
	W	10.55	0.05			2.52	0.08	1.08	0						5.17	0	
112	E	4.49	0.06			9.35	0.05										
	W	10.61	0.11			2.47	0.13	1.09	.01						5.15	0.02	
0	E	4.56	-0.01(a)			9.41	-0.01(a)										
	W	10.49	-0.61(b)			2.59	0.01(a)	1.08	0						5.17	0	

(a) This deflection indicates the amount by which the wall moved inward with reference to wall position prior to test.

(b) This deflection indicates the amount by which the wall moved outward with reference to wall position prior to test.

NOTE: During test load application, horizontal motion (oscillation) of the vertical walls at a height of 20 ft was as follows:

a. E wall - 0.02 ft to 0.03 ft.

b. W wall - 0.05 ft to 0.06 ft (load applied to this wall).

Table V. Simulated Combined (Snow and Wind) Load Stresses – Arch-Type Structure

Strain Gage No.	Stresses (ksi) at Load (psf + mph)					
	15 psf	15 psf 60 mph	15 psf 100 mph	15 psf 112 mph	25 psf	25 psf 60 mph
1	-16.5	-16.5	-20.1	-21.3	-26.1	-27.0
2	-0.6	-0.8	-1.8	-2.1	-2.1	-2.7
3	0	-0.9	-1.2	-1.5	-0.9	-1.8
4	0	0.3	.6	1.2	1.5	1.2
5	-0.9	-1.5	-1.5	-2.1	-2.1	-2.1
6	-0.9	-2.1	-2.1	-2.7	-2.4	-3.0
7	3.0	4.2	4.2	4.8	3.3	3.0
8	-0.6	-1.2	-1.8	-2.4	-1.5	-2.4
9	-3.6	-5.1	-5.1	-6.0	-5.4	-5.7
10	-3.9	-5.1	-5.1	-5.7	-5.4	-6.0
11	2.4	3.3	3.3	4.2	1.2	0.9
12	1.2	2.4	2.7	3.3	1.5	1.2
13	-3.0	-4.2	-4.5	-5.1	-3.9	-3.6
14	3.3	4.5	4.5	5.4	3.9	3.6
15	-4.2	-6.0	-6.3	-6.9	-6.3	-6.0
16	0.9	2.4	2.7	3.0	0.3	0
17	4.8	5.0	4.5	3.9	5.7	5.7
18	-2.7	-3.6	-3.9	-4.8	-3.0	-2.7
19	9.6	10.2	11.4	11.4	14.1	14.4
20	-13.2	-16.2	-16.2	-16.8	-24.0	-23.4
21	-2.7	-4.5	-4.5	-5.1	-3.9	-3.3
22	-3.3	-4.5	-4.8	-5.7	-3.6	-3.3
23	1.2	2.1	2.1	2.7	1.8	2.4
24	0.9	2.1	.9	1.8	0	-2.4
25	6.6	6.6	5.7	5.4	0.6	-0.6
26	3.6	3.9	3.6	3.6	-0.3	-1.2
27	-3.6	-3.9	-3.3	-3.3	-6.6	-7.8
28	-1.8	-1.8	-1.5	-0.9	-3.9	-5.1
29	-0.6	-0.6	-.3	-0.6	-1.5	-2.4
30	1.8	2.7	2.7	3.6	-4.8	3.9
31	-1.5	-1.2	-1.2	-0.9	-3.3	-4.2
32	-1.2	-1.5	-1.2	-0.9	-2.4	-3.3
33	-0.3	-0.3	0	0.3	-1.2	-2.4
34	-6.6	-6.9	-6.3	-6.3	-11.1	-12.3
35	-3.3	-3.6	-3.3	-3.3	-1.2	-6.0
36	-1.2	-1.2	-.6	-0.3	-2.1	-3.0

Table V (cont'd)

Strain Gage No.	Stresses (ksi) at Load (psf + mph)					
	15 psf	15 psf 60 mph	15 psf 100 mph	15 psf 112 mph	25 psf	25 psf 60 mph
37	-1.2	-1.8	-1.2	-0.9	-1.5	-2.1
38	-3.0	-2.4	-1.8	-1.8	-6.0	-5.7
39	5.7	6.0	5.4	5.4	9.6	10.5
40	-2.1	-3.0	-2.1	-1.8	-3.6	-3.9
41	2.4	3.3	2.4	2.7	4.5	4.8
42	-3.3	-3.9	-3.0	-3.0	-6.3	-6.6
43	-1.5	-2.1	-1.5	-1.5	-3.9	-4.2
44	-2.4	-3.0	-2.4	-2.4	-5.7	-6.3
45	3.3	4.5	3.6	3.6	6.9	7.5
46	3.2	3.6	3.6	3.5	5.8	6.1
47	-1.8	-1.9	-2.1	-2.3	-2.8	-2.7
48	-	-	-	-	-	-

Table VI. Simulated Combined (Snow and Wind) Load Deflections -- Arch-Type Structure

Applied Load (psf & mph)	Loc. of Inst.	Horizontal Deflections						Vertical Deflections					
		Near		Center		Far		Near		Center		Far	
		Orig. Dim. (ft)	Δb (ft)	Orig. Dim. (ft)	Δb (ft)	Orig. Dim. (ft)	Δb (ft)	Orig. Dim. (ft)	Δb (ft)	Orig. Dim. (ft)	Δb (ft)	Orig. Dim. (ft)	Δb (ft)
a. 24 June 1969													
0	E	4.50	0	9.36	0	9.36	0	1.04	0	8.50	0	5.20	0
	W	10.48	0	2.57	0	2.57	0	0.88	0.16	8.32	0.18	5.33	0.13
15 + 0	E	4.44	0.06	9.28	0.08	9.28	0.08	0.87	0.17	8.31	0.19	5.34	0.14
	W	10.36	0.12	2.69	0.12	2.69	0.12	0.85	0.19	8.29	0.21	5.34	0.14
15 + 60	E	4.47	0.03	9.32	0.04	9.32	0.04	0.85	0.19	8.32	0.18	5.33	0.13
	W	10.37	0.11	2.69	0.12	2.69	0.12	0.85	0.19	8.32	0.18	5.33	0.13
15 + 100	E	4.42	0.08	9.27	0.09	9.27	0.09	0.85	0.19	8.29	0.21	5.34	0.14
	W	10.42	0.06	2.62	0.05	2.62	0.05	0.85	0.19	8.32	0.18	5.33	0.13
15 + 112	E	4.41	0.09	9.27	0.09	9.27	0.09	0.85	0.19	8.32	0.18	5.33	0.13
	W	10.43	0.05	2.62	0.05	2.62	0.05	0.85	0.19	8.32	0.18	5.33	0.13
b. 25 June 1969													
25 + 0	E	4.37	0.13	9.22	0.14	9.22	0.14	0.78	0.26	8.21	0.29	5.43	0.23
	W	10.28	0.20	2.76	0.19	2.76	0.19	0.77	0.27	8.19	0.31	5.45	0.25
25 + 60	E	4.33	0.17	9.20	0.16	9.20	0.16	0.77	0.27	8.19	0.31	5.45	0.25
	W	10.32	0.16	2.72	0.15	2.72	0.15	0.77	0.27	8.19	0.31	5.45	0.25
c. 26 June 1969													
0	E	4.51	-0.01*	9.38	-0.02*	9.38	-0.02*	1.03	0.01	8.46	0.04	5.21	0.01
	W	10.43	0.05	2.60	0.03	2.60	0.03	1.03	0.01	8.46	0.04	5.21	0.01

* This deflection indicates the amount by which the wall moved inward with reference to wall position prior to test.

Table VII. Simulated Snow Load Stresses – Flat-Roof Structure

Strain Gage No.	Stresses (ksi) at Load (psf)					
	10 psf	15 psf	25 psf	27.4 psf	29.9 psf	32.4 psf
1	-5.4	-9.3	-15.9	-17.1	-12.9	-12.6
2	0	0	-0.3	0.6	4.5	4.8
3	-2.1	-4.5	-10.8	-8.7	-6.3	-7.5
4	0	0.3	0.6	2.7	5.7	6.0
5	0	0	0.3	2.4	5.4	6.0
6	-0.3	-0.3	-0.3	1.5	4.8	4.8
7	0	0.6	0.3	2.7	5.4	5.4
8	1.2	1.5	2.1	5.1	8.1	8.1
9	0	0	0.3	1.8	4.8	4.8
10	2.4	3.9	5.7	8.1	12.0	12.6
11	-2.1	-3.6	-7.2	-8.4	-6.3	-6.9
12	-8.1	-12.0	-22.2	-26.7	-26.4	-27.6
13	1.2	1.8	3.0	3.3	7.2	7.8
14	0.6	0.6	0.6	0.9	4.2	4.5
15	0.3	0	0	-1.2	1.8	2.1
16	2.1	3.3	4.8	6.9	10.8	11.4
17	-7.2	-10.5	-4.2	-30.6	-19.8	-14.1
18	-6.9	-10.8	-21.0	-21.3	-21.6	-23.7
19	0.3	0.9	1.5	2.7	6.3	6.6
20	0	0.3	0.6	1.5	4.8	5.1
21	-0.9	-1.2	-2.1	-1.8	0.9	0.9
22	0.9	1.2	1.5	2.4	6.0	6.6
23	-3.0	-4.5	-8.4	-9.0	-6.6	-6.6
24	-4.8	-8.1	-17.7	-12.0	-12.0	-13.8
25	-2.1	-2.7	-5.4	-6.0	-5.1	-5.4
26	7.2	9.9	16.5	18.0	22.2	24.3
27	-3.3	-5.1	-8.4	-9.6	-9.3	-9.9
28	-2.1	-2.4	-3.0	-2.7	-1.8	-1.8
29	-1.8	-2.1	-2.7	-3.0	-2.1	-2.4
30	-0.9	-1.5	-1.8	-3.6	-2.4	-2.7
31	0.3	0.3	0.6	0.3	1.2	-1.2
32	5.4	8.4	18.3	7.5	11.1	13.2
33	0.3	-0.9	-2.1	-3.6	-2.7	-2.7
34	0	0.3	0.6	-0.6	0	-0.3
35	1.2	2.1	3.3	2.1	3.0	3.3
36	2.1	3.6	6.3	4.2	5.7	6.0
37	-3.0	-5.4	-10.5	-12.3	-12.9	-14.7

Table VII (cont'd)

Strain Gage No.	Stresses (ksi) at Load psf					
	10 psf	15 psf	25 psf	27.4 psf	29.9 psf	32.4 psf
38	0.9	1.8	3.9	1.8	3.3	3.3
39	-4.2	-6.9	-11.7	-13.2	-14.4	-16.2
40	0.6	1.2	2.7	-0.3	1.2	1.2
41	1.2	1.5	2.4	0.6	1.8	2.1
42	-3.9	-6.9	-13.2	-15.6	-16.8	-19.2
43	-1.8	-3.0	-6.6	-5.4	-6.9	-7.5
44	6.3	8.7	15.3	15.3	15.6	18.3
45	0.6	0.6	1.5	2.1	1.2	1.5
46	-0.3	-0.9	-2.1	-2.1	-3.3	-3.3
47	-2.1	-3.6	-7.5	-6.6	-9.3	-9.6
48	0.3	0	-0.3	0.9	0.3	0.6

Table VIII. Simulated Snow Load Deflections - Flat-Roof Structure

Applied Load (psf)	Loc. of Inst.	Horizontal Deflections						Vertical Deflections					
		Near		Center		Far		Near		Center		Far	
		Orig. Dim. (ft)	Δb (ft)	Orig. Dim. (ft)	Δb (ft)	Orig. Dim. (ft)	ΔE (ft)	Orig. Dim. (ft)	Δb (ft)	Orig. Dim. (ft)	Δb (ft)	Orig. Dim. (ft)	Δb (ft)
a. 2 June 1969													
0	E	10.00	0	10.06	0	10.06	0	9.68	0	1.24	0	1.50	0
	W	4.29	0	9.02	0	9.02	0	9.68	0	1.24	0	1.50	0
10.0	E	10.00	0	10.06	0	10.06	0	9.58	0.10	1.35	0.11	1.60	0.10
	W	4.28	0.01	9.03	0.01	9.03	0.01	9.58	0.10	1.35	0.11	1.60	0.10
15.0	E	10.00	0	10.07	0.01	10.07	0.01	9.49	0.19	1.46	0.22	1.71	0.21
	W	4.28	0.01	9.04	0.02	9.04	0.02	9.49	0.19	1.46	0.22	1.71	0.21
25.0	E	10.02	0.02	10.10	0.04	10.10	0.04	9.23	0.45	1.74	0.50	1.99	0.49
	W	4.28	0.01	9.04	0.02	9.04	0.02	9.23	0.45	1.74	0.50	1.99	0.49
b. 3 June 1969													
27.4	E	10.04	0.04	10.09	0.03	10.09	0.03	9.16	0.52	1.84	0.60	2.08	0.58
	W	4.27	0.02	9.05	0.03	9.05	0.03	9.16	0.52	1.84	0.60	2.08	0.58
29.9	E	10.02	0.02	10.07	0.01	10.07	0.01	9.03	0.65	1.92	0.68	2.16	0.66
	W	4.27	0.02	9.04	0.02	9.04	0.02	9.03	0.65	1.92	0.68	2.16	0.66
32.4	E	10.03	0.03	10.07	0.01	10.07	0.01	8.98	0.70	2.02	0.78	2.29	0.79
	W	4.27	0.02	9.05	0.03	9.05	0.03	8.98	0.70	2.02	0.78	2.29	0.79
0	E	10.00	0	10.05	-0.01*	10.05	-0.01*	9.51	0.17	1.46	0.22	1.74	0.24
	W	4.28	0.01	9.04	0.02	9.04	0.02	9.51	0.17	1.46	0.22	1.74	0.24

* This deflection indicates the amount by which the wall moved inward with reference to wall position prior to test.

Table IX. Simulated Wind Load Stresses – Flat-Roof Structure

Strain Gage No.	Stresses (ksi) at Load (mph)				
	50 mph	60 mph	80 mph	100 mph	112 mph
1	0.2	0.5	0.5	0.5	0
2	0.2	-0.2	0.2	0.2	0
3	0	0	0.3	0.3	0
4	0	0	0	0	-0.2
5	0	0	0	0	0
6	0.2	-0.2	0.2	0.2	0.3
7	0	0	0	0	-0.2
8	-0.2	-0.2	0.2	0.2	0
9	0	0	0	0	0
10	0.2	0.2	0.2	0.2	0
11	0.2	0.2	0.2	0.2	0
12	0	0	0	0	0
13	0	0	0	0	-0.2
14	0.2	0.2	0.2	0.2	-0.2
15	0	0	0.2	0.3	0
16	0.3	0	0	0	-0.2
17	0	0	0	0.3	0.3
18	0.2	0.2	0.5	0.2	0.2
19	0.2	0.2	0.2	0.2	0
20	0.2	-0.2	0.2	0.2	0
21	0.3	0	0.3	0.3	-0.3
22	0.2	0.2	0.2	0.2	-0.3
23	0	0	0	0	0.3
24	0	0	0	0	0
25	-0.2	-0.2	-0.2	0.2	0
26	0.2	0.2	0.2	-0.2	0.2
27	0	0	0	0	-0.2
28	0.2	-0.2	0.2	-0.2	0
29	0.3	0	0.3	0	0.2
30	0	0	0	0	-0.2
31	0	0	0	0	0
32	0	0	0	0	-0.2
33	0	0	0	0	0
34	0.2	-0.2	0.2	0.2	0
35	0.2	-0.2	0.2	0.2	0
36	0	0	0.3	0	0
37	0.2	-0.2	-0.2	-0.2	0

Table IX (cont'd)

Strain Gage No.	Stresses (ksi) at Load (mph)				
	50 mph	60 mph	80 mph	100 mph	112 mph
38	0.2	-0.2	0.2	0.2	0
39	0	0	0	0	0
40	-0.2	-0.2	0.2	0.2	-0.3
41	-0.2	-0.2	0.2	0.2	0
42	-0.2	-0.2	-0.2	-0.2	-0.3
43	-0.2	-0.2	0.2	-0.2	-0.3
44	0	0	0	0	-0.5
45	0.2	0.2	0.2	0.2	-0.2
46	0.2	0.2	0.2	0.2	-0.2
47	-0.2	0.2	-0.2	-0.2	-0.3
48	-0.2	-0.2	-0.2	-0.2	-0.5

Table X. Simulated Wind Load Deflections -- Flat-Roof Structure

Applied Load (mph)	Loc. of Inst.	Horizontal Deflections						Vertical Deflections					
		Near		Center		Far		Near		Center		Far	
		Orig. Dim. (ft)	Δb (ft)	Orig. Dim. (ft)	Δb (ft)	Orig. Dim. (ft)	Δb (ft)	Orig. Dim. (ft)	Δb (ft)	Orig. Dim. (ft)	Δb (ft)	Orig. Dim. (ft)	Δb (ft)
0	E	10.00	0	10.04	0	10.04	0	9.72	0	1.20	0	1.47	0
	W	4.30	0	9.02	0	9.02	0	9.72	0	1.20	0	1.47	0
50	E	10.00	0	10.04	0	10.04	0	9.72	0	1.20	0	1.47	0
	W	4.30	0	9.02	0	9.02	0	9.72	0	1.20	0	1.47	0
60	E	10.02	-0.02*	10.06	-0.02	10.06	-0.02	9.72	0	1.21	0.01	1.47	0
	W	4.30	0	9.01	0.01	9.01	0.01	9.72	0	1.21	0.01	1.47	0
80	E	10.00	0	10.04	0	10.04	0	9.72	0	1.21	0.01	1.47	0
	W	4.30	0	9.02	0	9.02	0	9.72	0	1.21	0.01	1.47	0
100	E	9.98	0.02	10.02	0.02	10.02	0.02	9.72	0	1.21	0.01	1.47	0
	W	4.29	0.01	9.01	0.01	9.01	0.01	9.72	0	1.21	0.01	1.47	0
112	E	9.99	0.01	10.02	0.02	10.02	0.02	9.71	0.01	1.21	0.01	1.48	0.01
	W	4.29	0.01	9.01	0.01	9.01	0.01	9.71	0.01	1.21	0.01	1.48	0.01

* Horizontal deflection is in an outward direction during this applied load.

This report was prepared for the U.S. Army Corps of Engineers, Waterways Experiment Station, Vicksburg, Mississippi, under contract number W-33(616)-ENG-48. The work was performed by the University of Mississippi, Hattiesburg, Mississippi, under the supervision of Dr. J. H. Davenport. The work was completed in August, 1961.

Table XI. Simulated Combined (Snow and Wind) Load Stresses -- Flat-Roof Structure

Strain Gage No.	Stresses (ksi) at Load (psf + mph)		Strain Gage No.	Stresses (ksi) at Load (psf + mph)	
	15 psf 100 mph	27.4 psf 50 mph		15 psf 100 mph	27.4 psf 50 mph
1	-9.9	-14.1	25	-3.0	-5.1
2	0	2.4	26	9.6	19.2
3	-4.2	-6.9	27	-5.1	-9.0
4	0	4.2	28	-2.4	-1.8
5	0	3.9	29	-2.4	-2.4
6	-0.3	3.0	30	-1.8	-2.7
7	0.3	4.2	31	0.3	0.9
8	1.8	6.3	32	8.4	8.1
9	0	3.3	33	1.2	-3.0
10	3.9	9.9	34	0.3	-0.9
11	-3.9	-6.9	35	2.1	1.8
12	-12.3	-25.2	36	3.6	3.9
13	1.8	5.1	37	-5.4	-12.6
14	0.6	2.4	38	1.8	1.8
15	0	0.6	39	-7.2	-13.5
16	3.0	8.7	40	1.5	-0.3
17	-11.1	-29.1	41	1.2	0.3
18	-11.1	-19.8	42	-7.2	-15.9
19	0.6	4.2	43	-3.6	-6.3
20	0.3	3.0	44	9.0	14.4
21	-1.2	-0.6	45	0.6	1.2
22	0.9	4.2	46	-0.9	-2.7
23	-4.5	-6.9	47	-3.9	-7.8
24	-8.4	-10.5	48	0	0.3

Table XII. Simulated Combined (Snow and Wind) Load Deflections - Flat-Roof Structure

Applied Load (psf & mph)	Loc. of Inst.	Horizontal Deflections						Vertical Deflections						
		Near		Center		Far		Near		Center		Far		
		Orig. Dim. (ft)	Δb (ft)	Orig. Dim. (ft)	Δb (ft)	Orig. Dim. (ft)	Δb (ft)	Orig. Dim. (ft)	Δb (ft)	Orig. Dim. (ft)	Δb (ft)	Orig. Dim. (ft)	Δb (ft)	
a. 2 June 1969														
0	E	10.00	0		10.06	0								
	W	4.29	0		9.02	0		9.68	0	1.24	0	1.50	0	
15 + 100	E	10.00	0		10.07	0.01								
	W	4.27	0.02		9.04	0.02		9.49	0.19	1.46	0.22	1.71	0.21	
b. 3 June 1969														
27.4 + 60	E	10.02	0.02		10.07	0.01								
	W	4.27	0.02		9.05	0.03		9.17	0.51	1.84	0.60	2.08	0.58	

c. **Weathertightness.** The only watertightness tests conducted on the structures consisted of evaluating the effects of several rains during and after completion of the structures. The UFP design provides a self-draining roof except for the roof sag due to the dead weight of the material. This roof sag did permit an accumulation of water on the structures, and leakage was noticed. The leakage was in the form of drops, not a steady stream of water, over a major portion of the roof section of the two structures. The rate of leakage varied with location and was not measured. There appeared to be little difference in the leakage of the sections where the panel joints were caulked and those utilizing the elastomer gaskets.

d. **Post Tensioning.** The post tensioning performed by applying 4,000-lb tension in each of the 11 cables was totally insufficient to hold camber in the flat roof with the methods used. When load was released from the crane, the roof returned to its original sag condition.

e. **Test Beams.** The static loads applied to all four test beams (two straight and two curved) resulted in structural failure. This was intended in order to determine the critical areas for different types of loadings.

(1) **Straight Beams.** Static load was applied with vertical deflections recorded for each increment of load. Nine SR-4 strain gages were placed on the beams in the area of loading.

(a) **Straight Beam with Angle Transverse Stiffeners.** The maximum concentrated load applied to this beam was 8,000 lb. A weld failure occurred at a loading between 7,000 and 8,000 lb (Fig. 70). After this weld failure, load was increased to and held at 8,000 lb. Due to the test fixture setup, the piston travel of the hydraulic jack was not sufficient to increase the applied load beyond 8,000 lb. Therefore, all load was removed from the beam to modify the test setup for greater load application. Prior to additional load application, the beam was inspected and weld failure had occurred at another nodal point (Fig. 70). At this time, further testing of this beam was canceled. (See Fig. 71 for a plot of load versus deflection for the loading completed.)

(b) **Straight Beam with Six-Hole Transverse Stiffeners.** Structural failure occurred at three nodal points (Fig. 72). Distortion of these nodal points was noticeable at a load of 8,000 lb. Failure load was 10,000 lb. Typical failure was as shown in Figs. 73 and 74. (See Fig. 75 for a plot of load versus deflection.)

(2) **Curved Beams.** Static load was applied to the curved beams with horizontal and vertical deflection recorded for each increment of load.

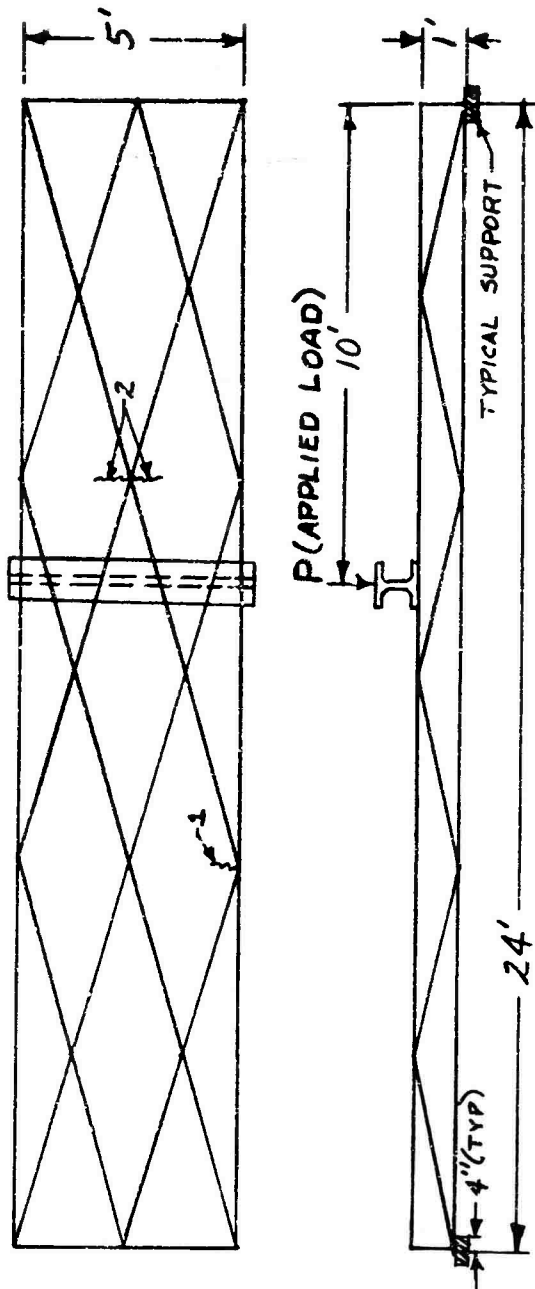

NOTE:

- 1 Denotes location of crack which occurred at loading of 7,000 to 8,000 lb. This crack exists in the full panel flange. Length of crack is flange width.
- 2 Denotes location of cracks which were located after the maximum load of 8,000 lb was removed from the beam. Load at which cracks occurred is unknown. Length of both cracks is the flange width.

Fig. 70. Straight test beam with angle transverse stiffeners.

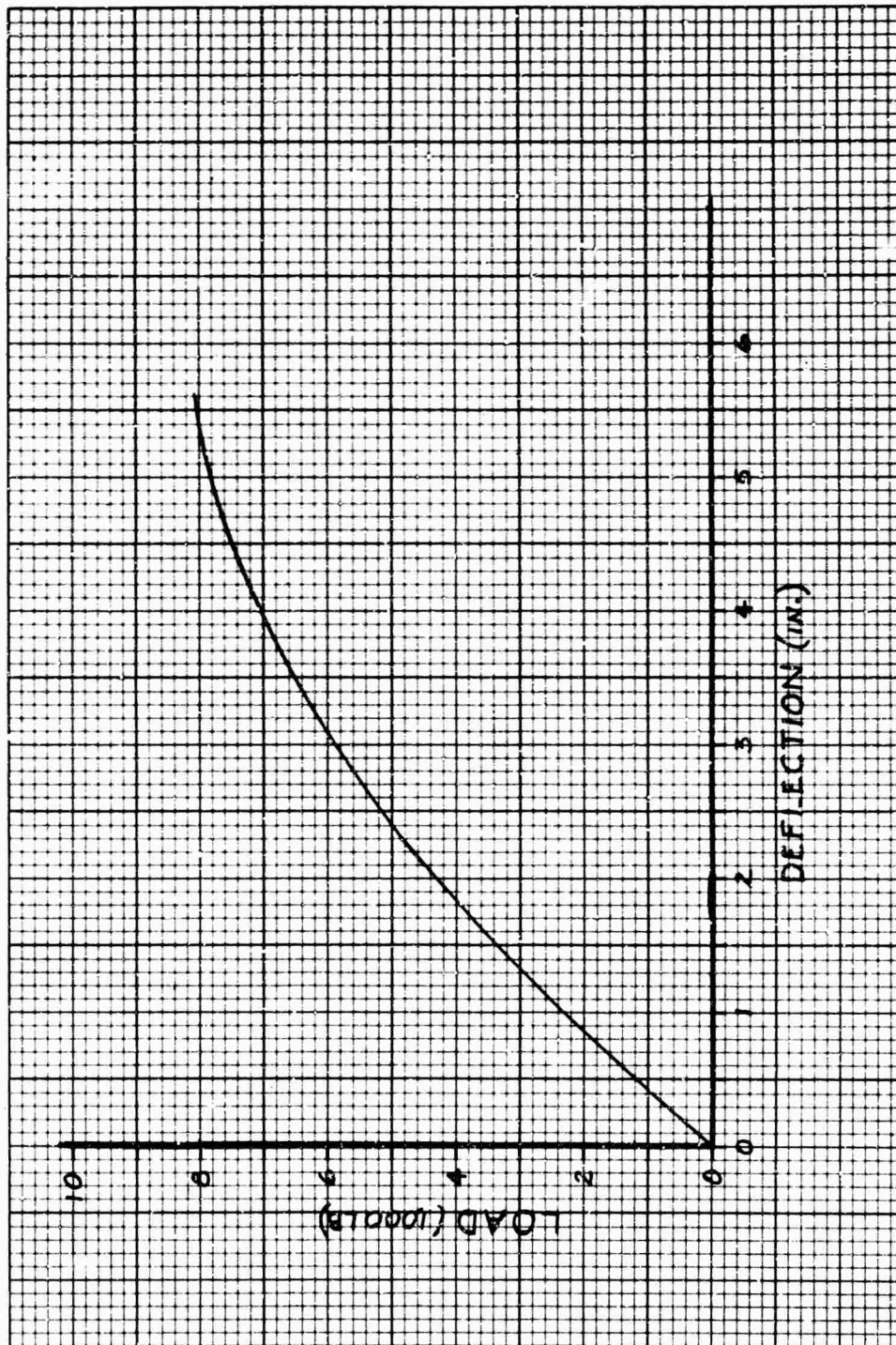
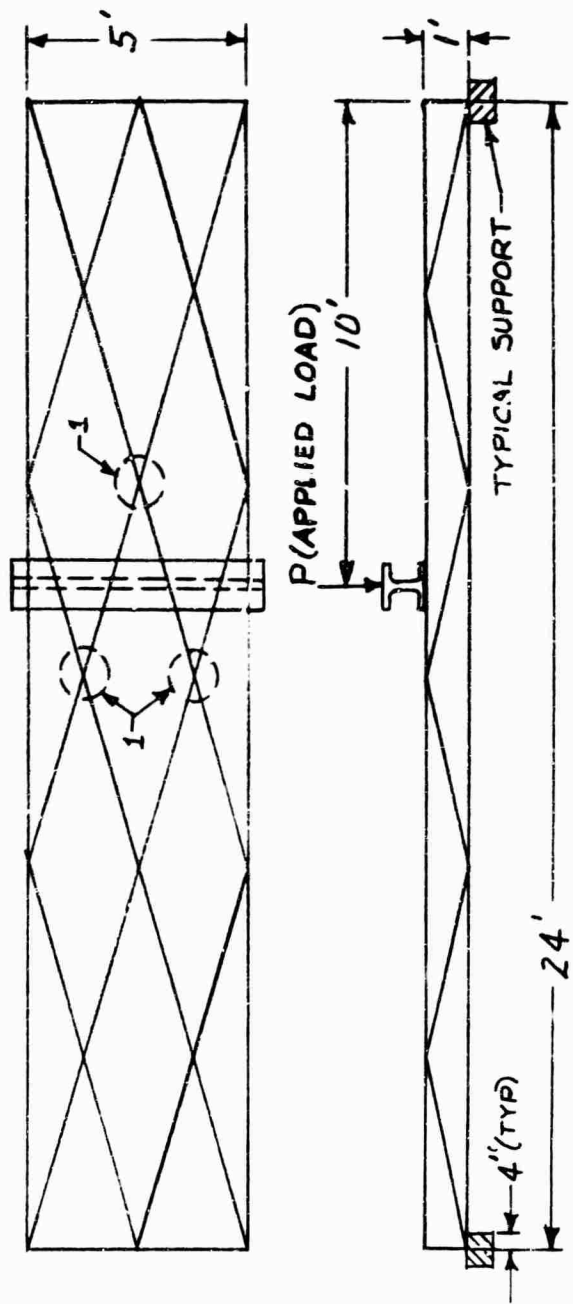

Fig. 71. Load versus deflection curve for straight test beam with angle transverse stiffeners.



NOTE:

1 Denotes nodal points at which structural failure occurred. See Fig. 73 and Fig. 74 for detail of the failures.

Fig. 72. Straight test beam with six-hole transverse stiffeners.

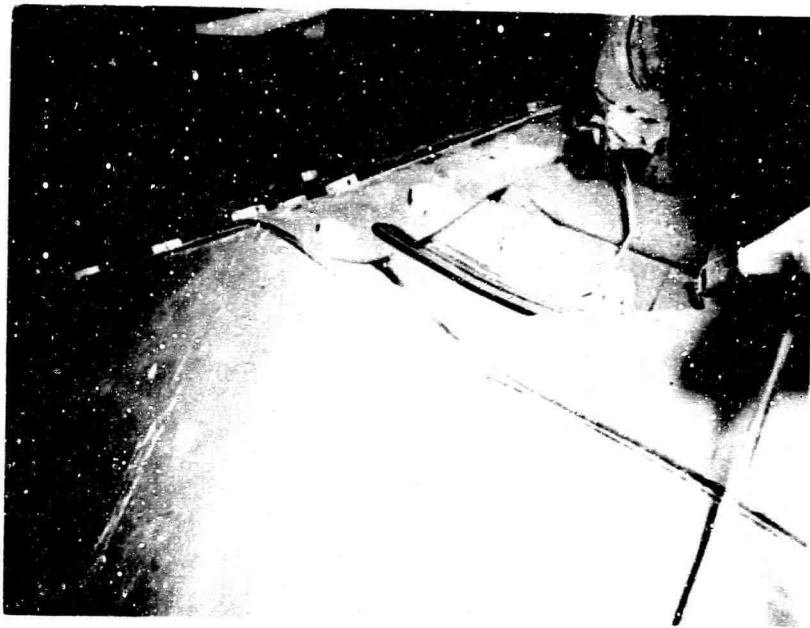

S5502

Fig. 73. Failure adjacent to nodal point on load side of beam.

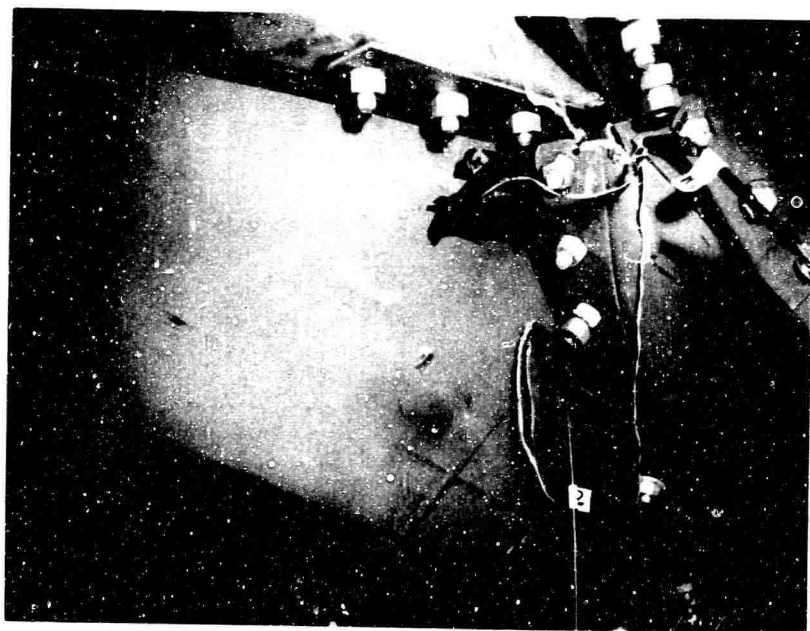

S5501

Fig. 74. Nodal point failure on side opposite load.

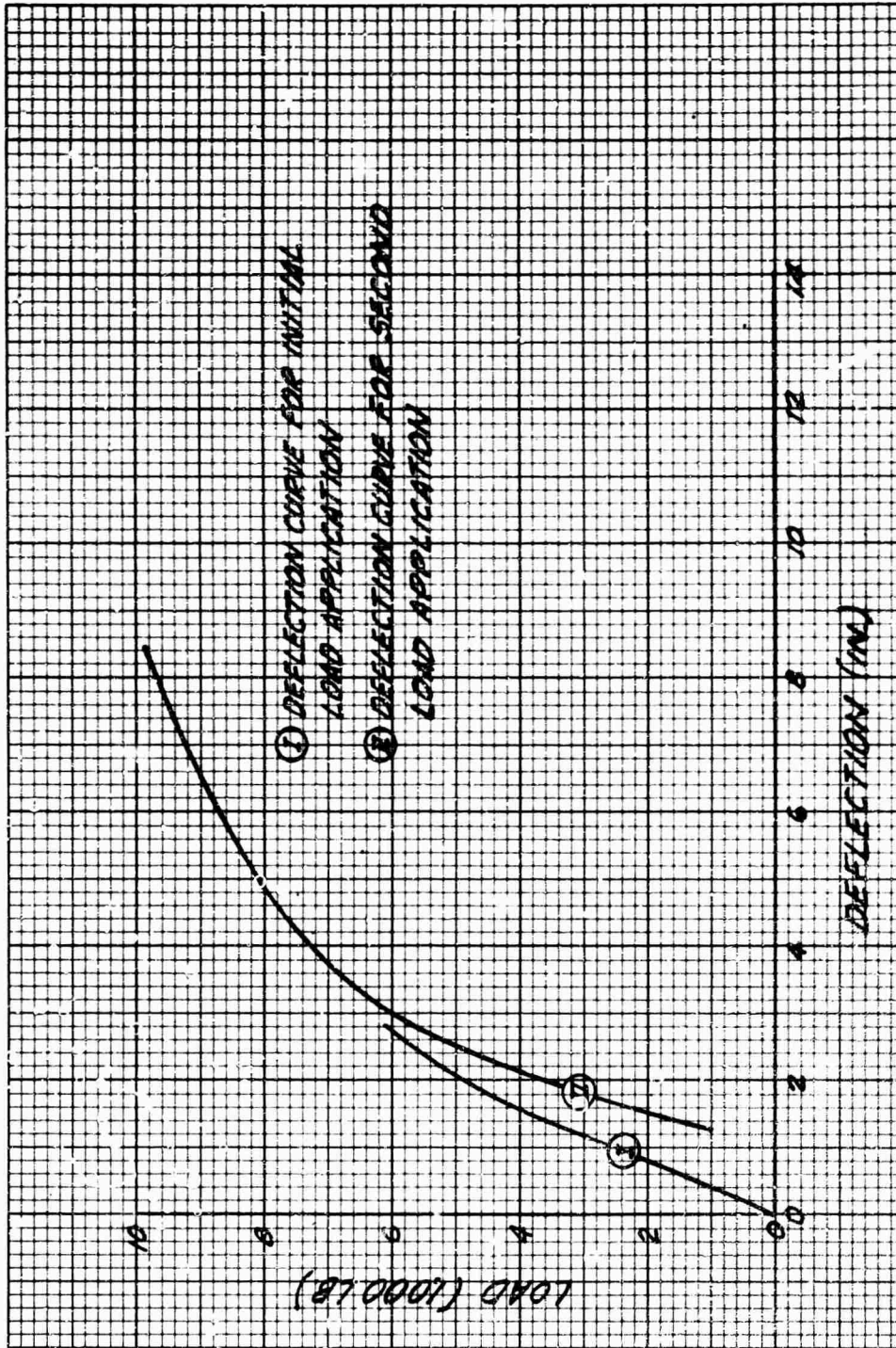

Fig. 75. Load versus deflection curves for straight test beam with six-hole stiffeners.

(a) **Curved Beam Without Transverse Stiffeners.** Structural failure occurred at a nodal point (Fig. 76). Failure load was 2,600 lb. Cracks propagated along the panel fold line in both directions from this nodal point. A plot of load versus deflection is shown in Fig. 77.

(b) **Beam with Angle Transverse Stiffeners.** Structural failure occurred at 6 in. from a nodal point at two locations as shown in Fig. 78. Failure load was 5,500 lb. A plot of load versus deflection is shown in Fig. 79.

(3) **Water Test Beam.** A watertightness test was performed on a test beam (Fig. 80) and on the flat-roof building. The results of this test on the flat-roof building are as shown in paragraph 7c. For the beam test, each of the two sections were filled with water to a maximum depth of 12 in. One section held water for a period of 48 hours; the other section leaked a steady stream of water. A gap existed between the mating gaskets at the nodal point where the leak existed. Leak rate was not measured.

III. DISCUSSION

8. Analysis of Test Results.

a. **Arch-Type and Flat-Roof Building Configurations.** The test loads applied demonstrated structural integrity of these building configurations utilizing the 10-gage design steel material. A review of the wind test results indicates that the test setup used to apply this test load was not adequate. The intended test wind load was not equally distributed over the required area. It is not known what total wind effect was actually applied to either building configuration. Although some of the gages indicated the intended wind loads, others indicated zero or small readings due to the deflected wind against the folded panels. The ultimate load-carrying capability of these two building configurations was not demonstrated. The limitations of time, personnel, and available funds precluded any further tests.

The stresses recorded in some of the areas appear questionable. The stresses recorded at the location of strain gage No. 20, Table I, may not be accurate because this channel of the recording machine would not remain in calibration after the 15-psf load application. This recording machine action could not be accounted for. The stresses recorded at the location of strain gage Nos. 1, 17, and 32, Table VII, appear to be erratic with no explanation available. Visual examination of these questionable areas does not indicate a structural problem.

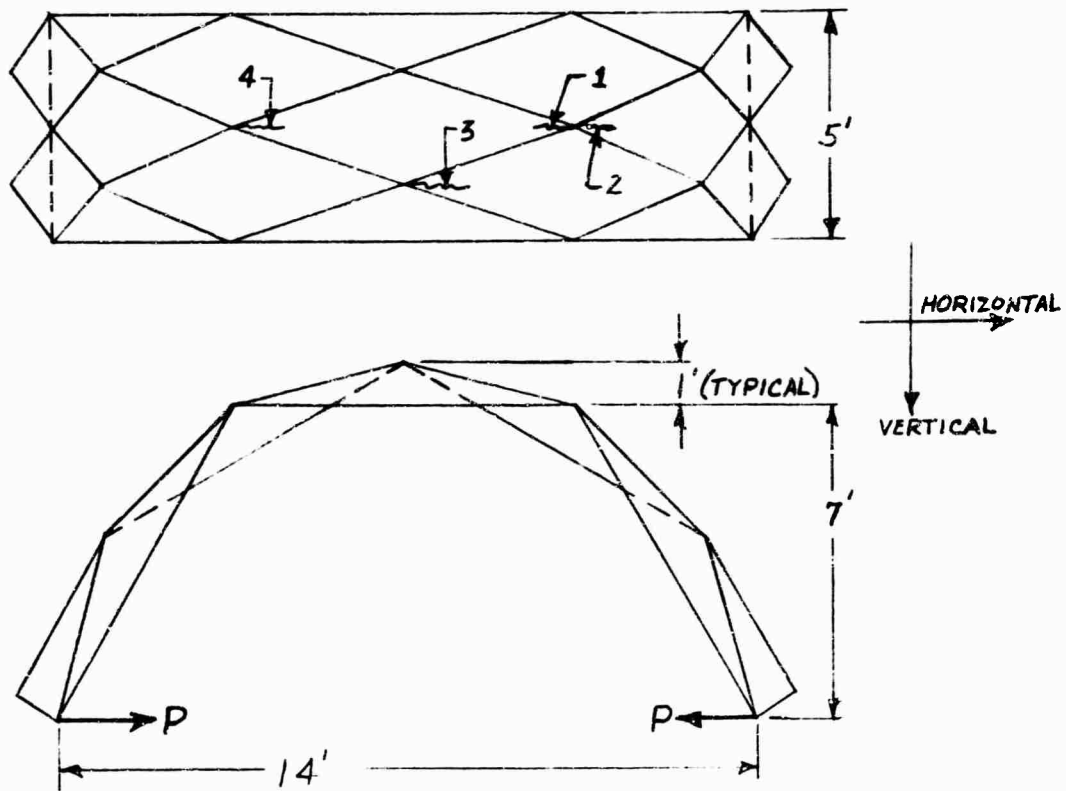

NOTE:

1, 2, 3, & 4 Denote cracks along panel fold line at locations shown.

Crack 1 = 1-3/4" length.

Crack 2 = 3" length.

Cracks 3 & 4 = 1-5/8" length.

Structural failure occurred at the nodal point common to location of cracks 1 & 2.

P Denotes location and direction of applied load.

Fig. 76. Curved beam test beam without transverse stiffeners.

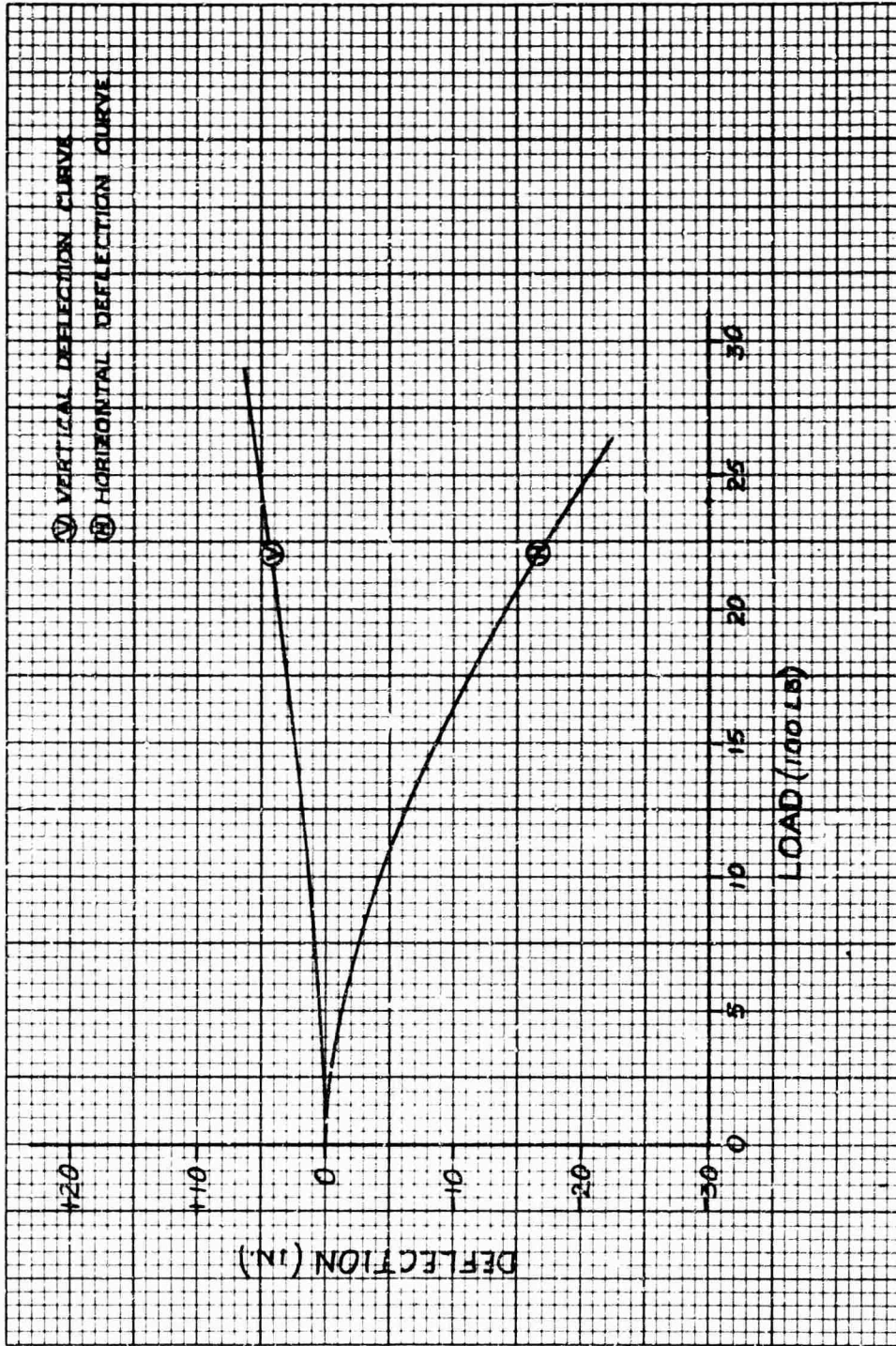
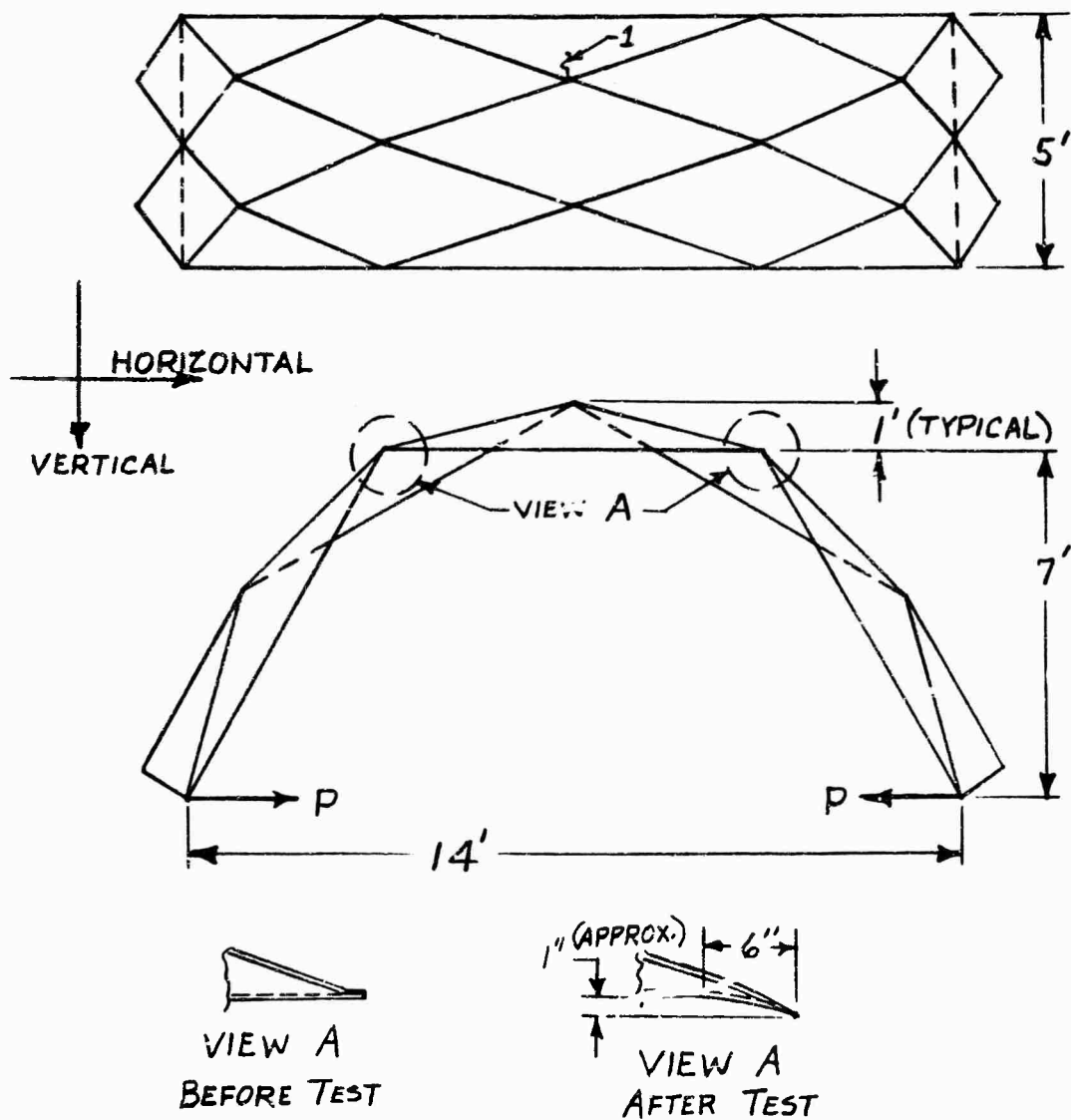

Fig. 77. Load versus deflection curves for curved test beam without stiffeners.



NOTE:

- 1 Denotes location of weld crack which occurred at an applied load of 3,500 lb. This crack exists in the longitudinal half panel flange. Length of crack is the flange width.
- P Denotes location and direction of applied load.

Fig. 78. Curved test beam with angle transverse stiffeners.

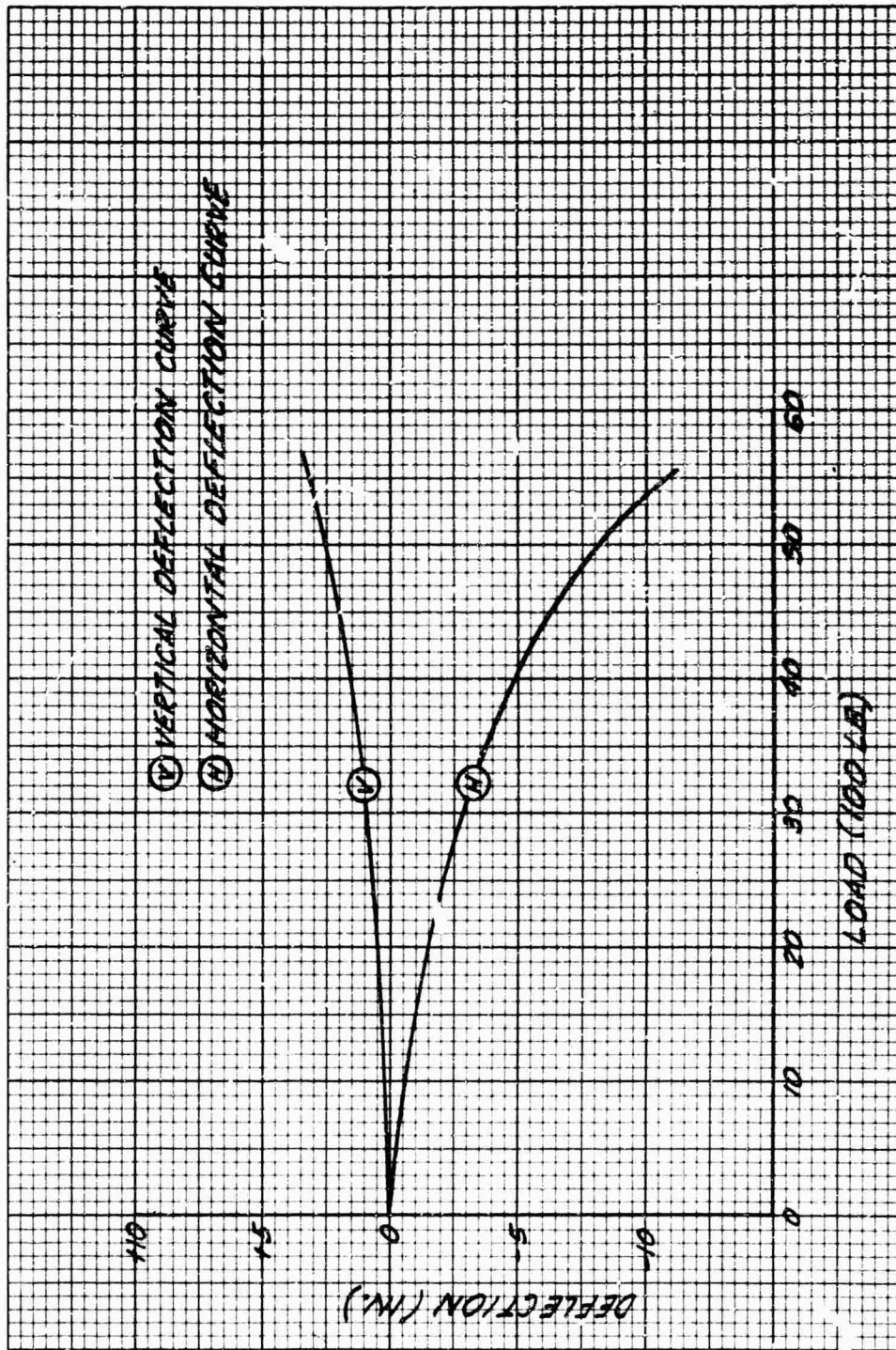

Fig. 79. Load versus deflection curves for curved test beam with stiffeners.



S3590

Fig. 80. Gasket sealing capability test.

Post tensioning of the flat roof was attempted without success. The system used was inadequate to eliminate roof sag. Post tensioning can be accomplished to remove the roof sag provided time, personnel, and funds are furnished to design the required system. It is also possible to use some other method to eliminate the roof sag condition. One method would utilize columns to support the roof except that this would interrupt the clear span.

Watertightness was evaluated based on the results observed during rainstorms. Both building configurations exhibited leaks. Leak rates were not measured. The leaks appeared to be at nodal points only. The joints which had the rubber gasket removed and caulking applied also leaked. The on-site caulking method of providing the watertightness seems to have more advantages than disadvantages over the permanently attached elastomer gaskets. This method would eliminate the gasket damage that occurred during shipment and handling of the UFP panels.

b. **Test Beams.** All of the test beams were loaded to failure as intended. The types of failures which occurred are as follows:

(1) **Weld Failure in Flange at Obtuse Angle.** This failure (Fig. 81) accentuated the result of poor welding. After failure, inspection of this area showed that improper welding existed. Weld penetration was less than 50 percent with weld bead buildup shaved flush to the flange material surface.

(2) **Crack in Parent Material Along Panel Fold Line.** This failure (Fig. 82) was the result of crack propagation of a forming crack which was not repaired. At time of panel fabrication, welding was accomplished as an attempt to eliminate this defect, but the crack was not removed.

(3) **Failure At and Adjacent To a Nodal Point.** This failure (Fig. 83) occurred in the straight beam with the six-hole transverse stiffeners. The crack is approximately 2 in. long with panel failure occurring within 10 in. in from the end of the panel at the acute angle. This failure occurred on only one side of the nodal point.

9. Nonstructural Evaluations.

a. **Weight.** The weight of each UFP component varies with material thickness used in fabrication. Only 10-gage steel was considered in this test and evaluation with the weight of the various UFP components as follows:

- (1) Full panel = 100 lb.
- (2) Longitudinal half panel = 50 lb.
- (3) Transverse half panel = 60 lb.
- (4) Angle transverse stiffener (three-hole) plus seven nuts and seven bolts = 12 lb.

b. **Manufacturing Quality.** During fabrication, cracks occurred in the steel along the UFP panel fold line at the acute angle end. These cracks start at the edge and propagate into the metal with length varying from 1/4 in. to 1 in. The cracks existed in a majority of the UFP panels obtained for this test and evaluation. A weld repair of the crack areas was attempted without much success as 100-percent penetration was not obtained and the cracks remained visual on one side of the material. The flanges were cut at the obtuse angle to allow for forming. After forming, the flanges were welded to form a continuous flange, but a majority of these weld areas exhibit less than 50-percent weld penetration with basically no weld in some areas.

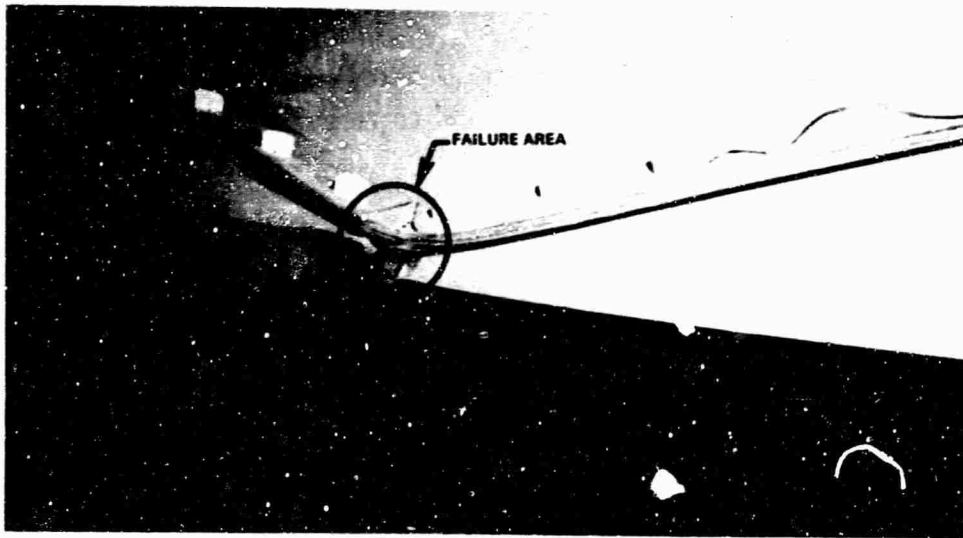

S3608

Fig. 81. Flange weld failure at obtuse angle of panel.

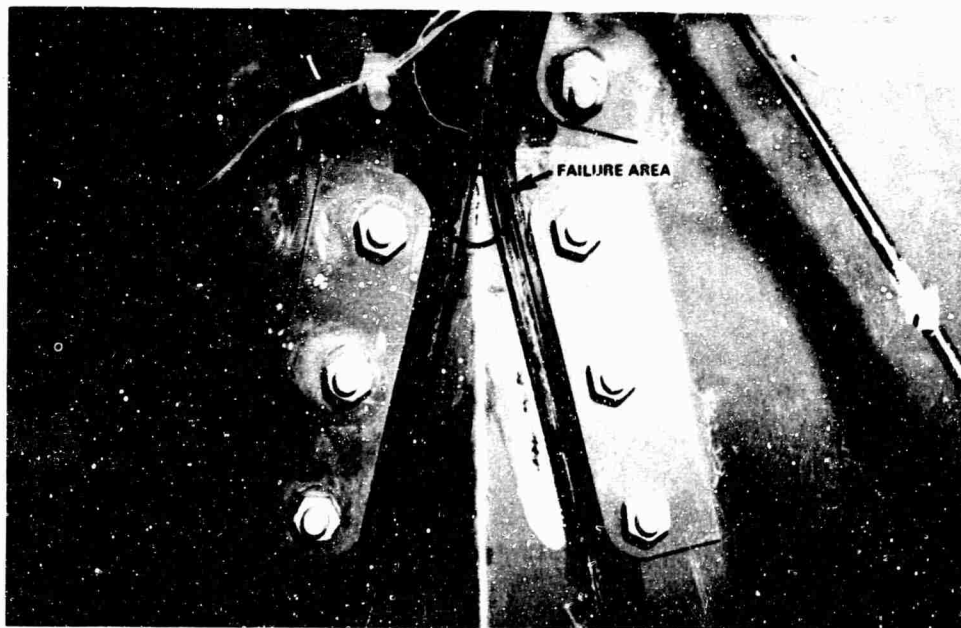

S3619

Fig. 82. Crack in parent material along panel fold line propagating from obtuse angle end of panel.

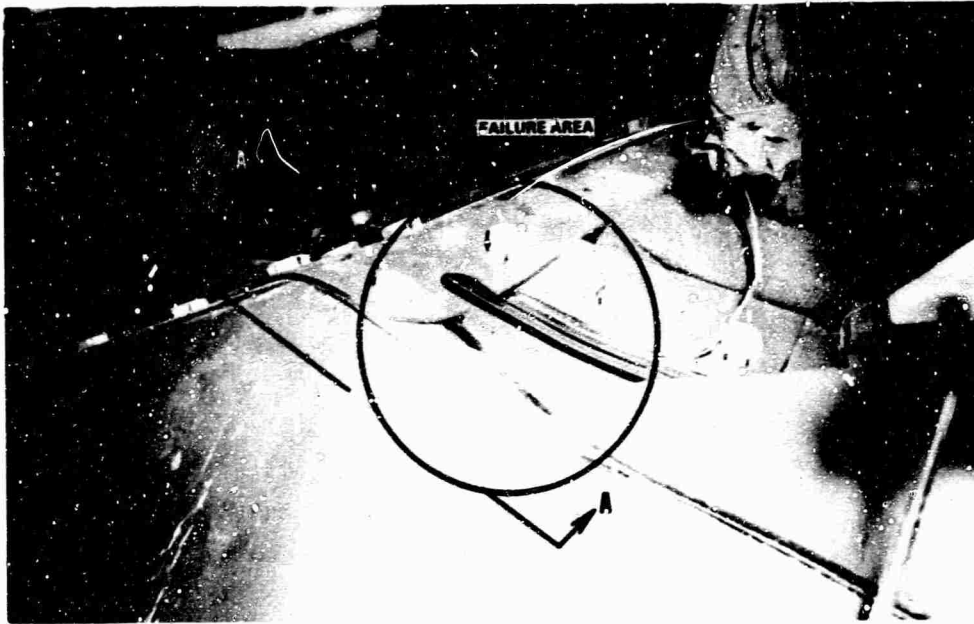

S5502

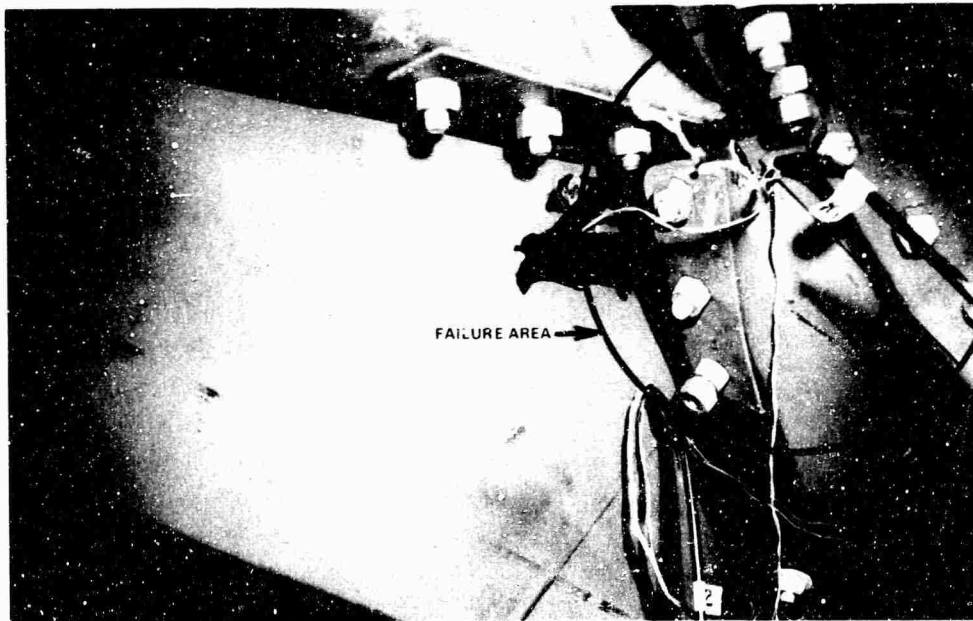

S5501

Fig. 83. Failure at and adjacent to nodal point.
(View A--A shown in bottom photograph.)

As a result of bolt hole misalignment during erection, five random panels were set aside, and the transverse stiffeners were laid loosely in place across the panels. This produced a hole misalignment of from 1/8 in. to 3/8 in. The transverse stiffener dimensions were according to design. Two other panels were picked at random and checked dimensionally. The existing dimensions of these two panels are as shown in Figs. 84 and 85. A comparison of the panels shown in Figs. 84 and 85 with the design drawing (Fig. 4) will show that the panels have been fabricated with the following existing discrepancies:

- (1) Improper hole location.
- (2) Panel fold angle not equal to 90°.
- (3) Panel flanges out of plane (not flat).

It is felt that the UFP panels can be manufactured within the design tolerances with the availability of matched metal dies. All panels used for the tests were hand-fabricated on brake forming equipment.

e. **Erection.** The equipment required for erection of any building using UFP panels will vary with the configuration constructed. Experience gained in the erection of the two building configurations indicates that a system of jacks or other lifting devices could be readily designed for use in erection of the UFP structural system. Then equipment such as cranes and forklifts would not be necessary for construction of a majority of the military building configurations. However, it is felt that for a building such as the arch-type aircraft hangar a crane and forklift will always facilitate erection.

The building configurations were erected without any technical difficulty. During joining of the panels, hole misalignment made bolt installation more difficult and increased erection time. Erection time for the arch-type building was 1.2 man-hours per panel using an average work crew of five men (civilians). Erection time for the flat-roof building was 2.6 man-hours per panel using an average work crew of two civilians and eight military (enlisted) men. It is felt that erection times can be reduced if all panels are made within design tolerances. Also, hole alignment would be improved and erection time reduced if the bolt hole diameter was increased to 13/16 in. The erection time reduction due to system refinements cannot be estimated at this time.

d. **Transportability.** The UFP panels lend themselves well for shipment. The panels nest together (Figs. 86 and 87) to minimize cubage required for shipment.

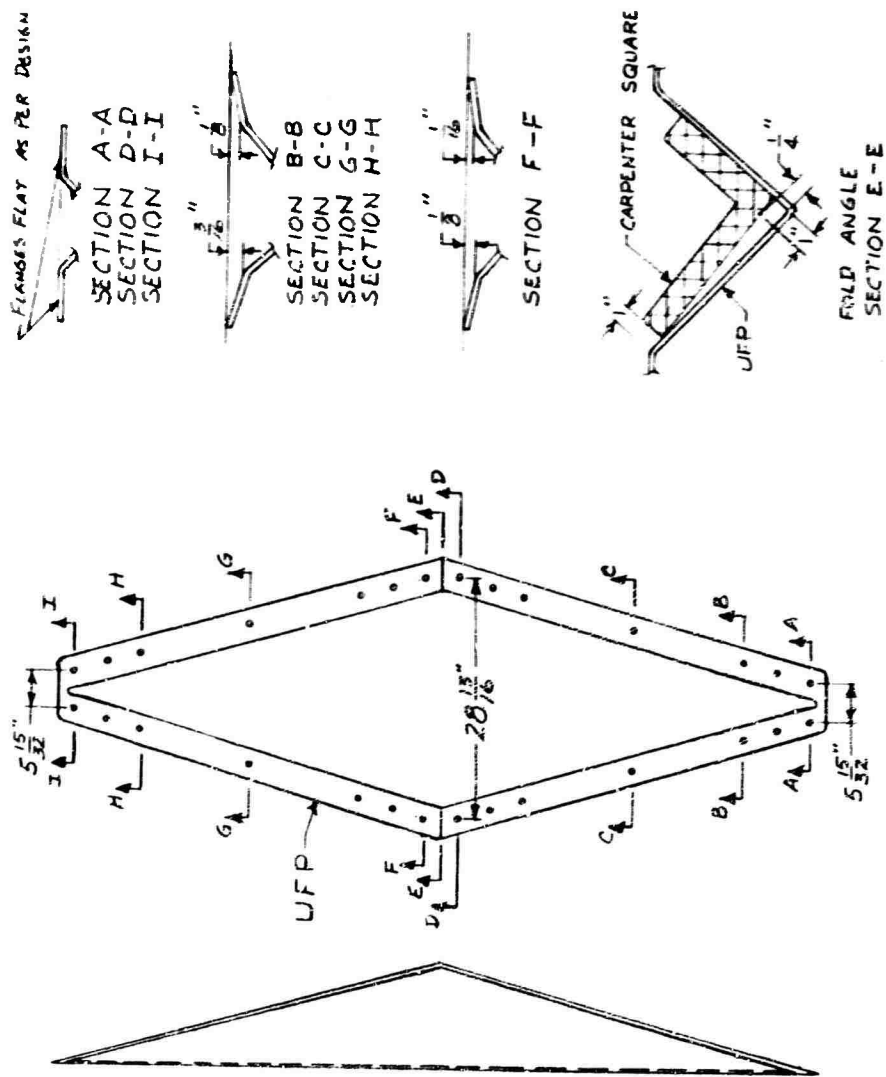

NOTE: Only dimensions other than design $\pm 1/32$ are shown.

Fig. 84. Manufacturing tolerance check - panel 1.

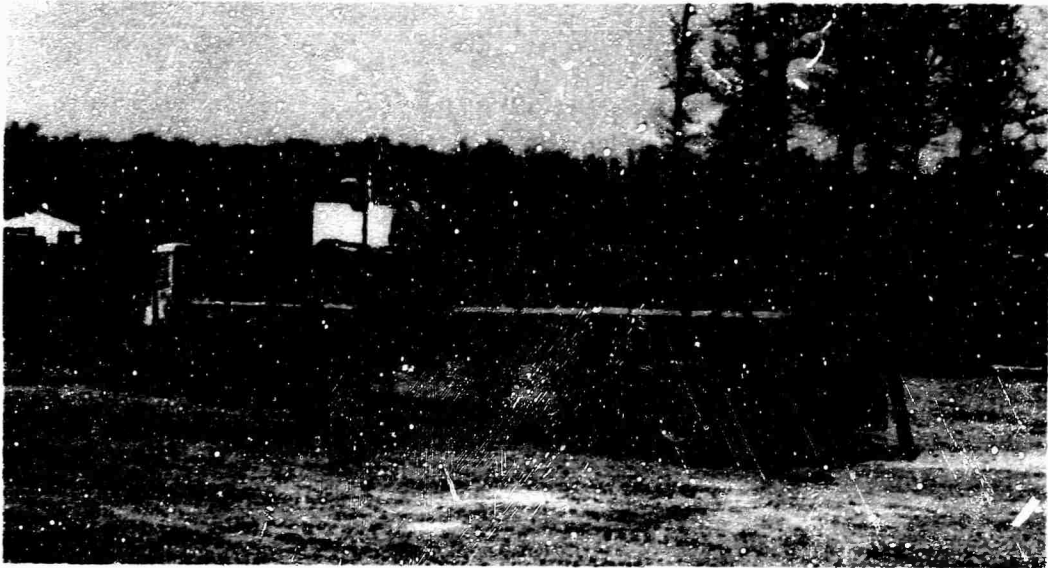

Fig. 86. Truckload of UFP components.

S3607

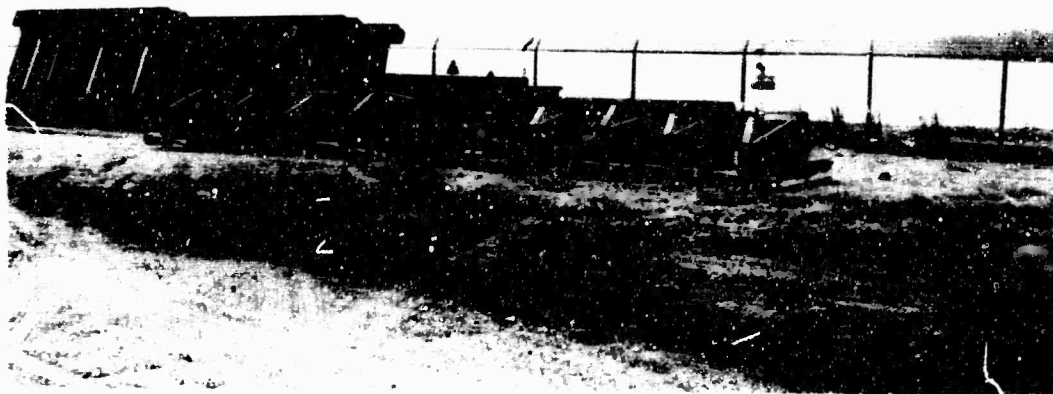

Fig. 87. Palletized UFP.

S3611

Weight instead of cubage will generally control the shipment size for the steel panels. The full panels were placed on 3-ft by 9-ft pallets.

e. **Insulation.** No attempt was made to provide or evaluate insulation of the UFP system because of limited time, personnel, and funds.

10. Related Evaluations.

a. **Transverse Stiffener Modification.** Because of the inadequate welding of the flanges at the obtuse angle of the panels and the existence of crack along the fold line at the acute angle of the panels, the inventor proposed to furnish the six-hole transverse stiffener as a method of reinforcing the weakened structural areas. The six-hole transverse stiffeners were furnished at no cost to USAMERDC under a contract modification. Both of the building configurations were complete when the six-hole transverse stiffeners were received. Therefore, the angle stiffeners were replaced on the flat-roof building only, to avoid interruption of the test program.

b. **End Walls.** At this time, an end-wall design does not exist for all configurations of the UFP structural system. A suggested approach has been submitted by the inventor of the UFP system, but the available time, personnel, and funds did not allow for exploration of this area. Various end-wall designs could be used since the test results indicated that the end walls need not be designed to be load-carrying. The type of end wall required may be determined by the intended use of the building.

c. **Penetration.** At present, there is no existing design for doors, windows, etc. for the UFP system although it appears that this should not present a technical barrier. Openings of various sizes or shapes can be made by eliminating or substituting panels. No effort was expended in this area because of the limited time, funds, and personnel.

d. **Nodal Connector.** The use of nodal connectors could be one method of system refinement which would increase the structural capability, decrease erection time, and improve achievement of watertightness. The nodal connector would be a one-piece structural member which would span the nodal point and envelop the area of the present 12-bolt locations at each node. This connector could be of such design that the 12 bolts would be replaced by two or four tension-type fasteners incorporated into the connector with the remainder of the 12 bolt locations being used by shearpins built into the nodal connector. From structural failures achieved during testing of the UFP system, the critical stresses occur at or near the nodes. The nodal connector would structurally reinforce this critical area. It is probable that, if the number of bolts required for panel connection is reduced, then erection time will also decrease. This would be achieved by incorporating the nodal connector into the UFP system. Since

water leakage was observed at nodal points only, this nodal connector could be an aid in achieving the desired watertightness required in a shelter.

e. **Other Test and Evaluation Effort.** The U. S. Navy, in conjunction with the U. S. Air Force, has erected a hardened aircraft shelter for test and evaluation. The UFP structure was covered with 12 to 18 in. of concrete and subjected to ballastic tests. These tests were conducted at the Hill Air Force Base test range near Salt Lake City, Utah. The UFP structure was evaluated in conjunction with Air Force shelters under their "Concrete Sky" program. An Air Force report is being prepared covering the tests.

IV. CONCLUSIONS

11. **Conclusions.** On the basis of the limited test and evaluation performed, it is concluded that:

a. Structural integrity can be maintained for various shapes and sizes of shelters within the limits of the building configurations tested. Structural testing of the two buildings showed no stresses in excess of accepted allowables.

b. Watertightness, as achieved by the designed sealant gasket and by the method of caulking as performed after erection of the flat-roof building, was not satisfactory.

c. A number of various building configurations can be constructed using the single UFP component structural system since the panels are reusable, interchangeable, and reversible.

d. No special foundation or foundation preparation is necessary in areas where the soil is capable of withstanding the weight of the building plus design loads. Where the ground is to be the foundation, only a smooth surface is required.

e. The UFP structural system appears to be readily adaptable to hardened shelter concepts for use by the military.

f. Additional test and evaluation is necessary to determine full military potential. A cost-effectiveness study should be included in the total evaluation.

APPENDIX

UNIVERSAL FOLDED PLATE (UFP) SHELL STRUCTURES

Plan of Test for FS/EDT

11 Mar 1969

1. **Purpose.** The purpose of this test is to determine the structural adequacy of the UFP system and to evaluate the UFP system to determine potential military use.

2. **Authority.** Authority for this test is contained in a directive:

To: USAMERDC, (SMEFB-CO), Subject: Investigation and Evaluation of Universal Plate (UFP) Structures, dated 5 August 1968, From: AMCRD-JG and in AMC Form 1006A for Project/Task 1J662708D550/07, Prefabricated Shell Building Systems, From: AMCRD-J, To: USAMERDC, (SMEFB-CB), dated 1 August 1968.

3. **Scope.**

a. This test will furnish a limited amount of information on which to base a determination of the structural adequacy of the UFP system. This information will be limited due to the availability of 10-gage steel UFP only and to the limited time, personnel, and funds available to conduct this test and evaluation.

b. This test consists of the erection, application of design load, and system evaluation based on the building configurations shown in Figs. 6 and 7. The building configuration shown in Fig. 6 will be constructed to a length of approximately 40 ft while that shown in Fig. 7 will be constructed to a length of approximately 25 ft. All of the UFP panels used in the construction of the test configurations will be 10-gage steel.

4. **Tests.**

a. **Equipment Required.** The equipment required to conduct this test is as follows:

- (1) Forklifts.
- (2) Cranes.
- (3) Portable generator.

- (4) Airboat motors with propellers.
- (5) Handtools.
- (6) Jacks (hydraulic and ratchet).
- (7) Lumber.
- (8) Wire rope.
- (9) Surveying transit.
- (10) SR-4 strain gages.
- (11) Strain gage readout equipment.
- (12) Air velocity meters.
- (13) Any other equipment necessary for performance of this test.

b. **Test Site.** The test site will be the open area at the ponton basin adjacent to Building 337. This site will be approximately level with an area of sufficient size to allow for full utilization of equipment used during erection and structural testing. It is intended that the site area be of a size to accommodate both of the building configurations shown in Figs. 6 and 7. The existing ground will serve as the building foundation.

c. **Erection.** The erection of the building configurations shown in Figs. 6 and 7 will be accomplished with the equipment listed in paragraph 4a. During building construction, the erection methods and techniques will be varied in an attempt to arrive at an optimum erection method along with the necessary erection aids.

d. **Test Loads.**

(1) Test loads applied will be the design live loads multiplied by the factor of safety. Maximum allowed loads which the structure will safely support will be applied if time and personnel permit. The design loads are:

- (a) Dead load \cong 10 psf.
- (b) Live load:

1. Snow load = 25 psf.
2. Wind load = 30 psf @ 30 ft height for wind = 80-100 mph.
3. Factor of safety = 1.25.

(2) **Snow Load.** Snow loads will be simulated by placing sandbags on the roof area. The sandbags will be placed in such a manner that the uniformly distributed load required is achieved. This load will be applied in increments until the test load is reached. Strain gage readings, deflections, and any other structure behavior will be recorded for each increment of load applied.

(3) **Wind Load.** Wind loads will be simulated by setting airboat motors with propellers in a pattern such that one wall of the building will be subjected to the wind as produced. This wind loading will be applied in increments until the test load is reached. Strain gage readings, deflections, and any other structure behavior will be recorded for each increment of load applied. Air velocity meters will be placed along the wall to allow for recording the wind pattern as applied. An alternate method using cables and dynamometers will be used to simulate wind loads if the above method is determined to be inadequate.

e. **Watertightness.** The watertightness (sealing capability) of the UFP system will be determined by directing a water spray onto the erected building configurations. It may also be necessary to assemble a few panels into an inverted arch configuration and to fill this with water to determine the watertightness. Any leakage will be recorded.

f. **Disassembly.** After completion of the tests of the erected building configurations, the erection procedures will be reversed. Both of the building configurations will be completely disassembled. All structural components will be inspected for evidence of distress or failure which was not evidenced during the load testing. Any discrepancy noted will be recorded.

g. If time and funds permit, straight and curved beams of varying length will be constructed. Static loads will be applied to these beams to determine structural capability and points of maximum stress. This information will be correlated with the results of the tests performed on the building configurations erected to provide additional information for prediction of the behavior of various other building configurations.

5. **Photography.** The erection of the building configurations and testing will be covered by still photography.

6. Evaluation. After completion of testing, all data recorded will be tabulated and evaluated to determine potential of the UFP structural system.

a. Structural Evaluation. This will involve evaluation of the items pertaining to the strength or load carrying capability of the UFP system based on the configurations tested. These items to be evaluated are:

- (1) Stresses.
- (2) Deflections.
- (3) Bearing reactions.
- (4) Watertightness.
- (5) Post tensioning requirements.
- (6) Reinforcing requirements.
- (7) Sidewall anchoring.

b. Other Consideration to be Evaluated.

- (1) Erection methods.
- (2) Erection times.
- (3) Erection aids.
- (4) End walls and closures.
- (5) Penetration.
- (6) Transportability (weights, cube, etc.).
- (7) Methods of insulation.
- (8) Any other items pertaining to military buildings.

7. Report. A report covering the results of the tests and evaluations will be prepared.

UNCLASSIFIED

Security Classification

DOCUMENT CONTROL DATA - R & D		
<i>(Security classification of title, body of abstract and indexing annotation must be entered when the overall report is classified)</i>		
1. ORIGINATING ACTIVITY (Corporate author) U. S. Army Mobility Equipment Research and Development Center Fort Belvoir, Virginia		2a. REPORT SECURITY CLASSIFICATION Unclassified
		2b. GROUP N/A
3. REPORT TITLE UNIVERSAL FOLDED PLATE (UFP) STRUCTURAL SYSTEM		
4. DESCRIPTIVE NOTES (Type of report and inclusive dates) Final Report 1969		
5. AUTHOR(S) (First name, middle initial, last name) Edward J. Schultze Lloyd E. Krivanek		
6. REPORT DATE January 1970	7a. TOTAL NO. OF PAGES 122	7b. NO. OF REFS
8a. CONTRACT OR GRANT NO. A. PROJECT NO. Task No. 1J662708D55007	9a. ORIGINATOR'S REPORT NUMBER(S) 1974	
9b. OTHER REPORT NO(S): (Any other numbers that may be assigned this report)		
10. DISTRIBUTION STATEMENT This document has been approved for public release and sale; its distribution is unlimited.		
11. SUPPLEMENTARY NOTES	12. SPONSORING MILITARY ACTIVITY USAMERDC Fort Belvoir, Virginia	
13. ABSTRACT This report covers the limited engineer design tests and evaluation of the Universal Folded Plate (UFP) Structural System. The UFP structural system is comprised of full-size, folded, diamond-shaped panels; longitudinal half panels; and transverse half panels which can be fastened together to construct shelters of various shapes and sizes. Two different structures were erected and structurally tested. One was an arch-type structure 52 ft wide, 49 ft long, and 36 ft high; the other was a flat-roof structure 54 ft wide, 25 ft long, and 15 ft high. On the basis of the limited test and evaluation performed, it is concluded that: a. Structural integrity can be maintained for various shapes and sizes of shelters within the limits of the building configurations tested. Structural testing of the two buildings showed no stresses in excess of accepted allowables. b. Watertightness, as achieved by the designed sealant gasket and by the method of caulking as performed after erection of the flat-roof building, was not satisfactory. c. A number of various building configurations can be constructed using the single UFP component structural system since the panels are reusable, interchangeable, and reversible. d. No special foundation or foundation preparation is necessary in areas where the soil is capable of withstanding the weight of the building plus design loads. Where the ground is to be the foundation, only a smooth surface is required. e. The UFP structural system appears to be readily adaptable to hardened shelter concepts for use by the military. f. Additional test and evaluation is necessary to determine full military potential. A cost-effectiveness study should be included in the total evaluation.		

DD FORM 1473
1 NOV 65

REPLACES DD FORM 1473, 1 JAN 64, WHICH IS OBSOLETE FOR ARMY USE.

UNCLASSIFIED
Security Classification

14. KEY WORDS	LINK A		LINK B		LINK C	
	ROLE	WT	ROLE	WT	ROLE	WT
Structure Shelter Prefabricated Shell building Building Interchangeable Reusable Transportable Military Field erection Bolt-connected Variable size of structure Variable structure configuration Folded plate						