

AD 702525

ARL-TR-70-1

MULTI-CHANNEL TRANSDERMAL STIMULATION OF THE BRAIN

José M. R. Delgado, M.D.
Yale University School of Medicine

February 1970

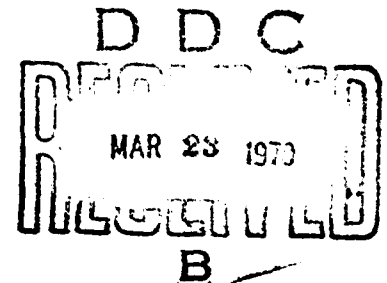

This document has been approved for public release and sale; its distribution is unlimited.

**6571st Aeromedical Research Laboratory
Aerospace Medical Division
Air Force Systems Command
Holloman Air Force Base, New Mexico**

Reproduced by the
CLEARINGHOUSE
for Federal Scientific & Technical
Information Springfield, Va. 22151

Animals used in this study were handled in accordance with the "Guide for Laboratory Animal Facilities and Care" prepared by the National Academy of Sciences - National Research Council and in accordance with the Secretary of Agriculture Standards in "Laboratory Animal Welfare!"

This report may be reproduced to satisfy needs of U.S. Government agencies. No other reproduction is authorized except with permission of the 6571st Aeromedical Research Laboratory, Holloman AFB, NM.

This report is made available for study with the understanding that proprietary interests in and relating thereto will not be impaired. In case of apparent conflict or any other questions between the Government's rights and those of others, notify the Judge Advocate, Air Force Systems Command, Andrews Air Force Base, Washington, D.C.

Do not return this copy. Retain or destroy.

| | | |
|--------------------|-------------|--------------------------|
| ACCESSION | | |
| POST | SECTION | <input type="checkbox"/> |
| NO | OFF SECTION | <input type="checkbox"/> |
| NO | SECTION | <input type="checkbox"/> |
| AVAILABILITY CODES | | |
| JUST. | AVAIL | OR OF SPECIAL |
| 1 | | |

MULTI-CHANNEL TRANSDERMAL STIMULATION OF THE BRAIN

**Jose M. R. Delgado, M.D.
Yale University School of Medicine**

**This document has been approved for public release and sale; its
distribution is unlimited.**

FOREWORD

This research was conducted by the Yale University School of Medicine under Contract No. F29600-67-C-0058 from 1 July 1967 to 31 December 1969. The contract was monitored by Captain Jan D. Wallace, Bio Effects Division, 6571st Aeromedical Research Laboratory under project 6892, Task 02.

The views expressed herein are those of the author and do not necessarily reflect the views of the U. S. Air Force or the Department of Defense.

This technical report has been reviewed and approved for publication.



ROBERT G. McIVER, Colonel, USAF, MC
Commander

ABSTRACT

A system has been developed for multichannel electrical stimulation of the brain through the intact skin. The stimulator which is implanted subcutaneously, has no batteries and may be used for the lifetime of the experimental subject. Power and information are provided by a small pack carried externally and activated by radio (100 MHz). A combination pulse width and frequency modulation technique is employed to encode the signal information. Three channels are available and in each, repetition rate, pulse durations, and intensity are remotely controlled, allowing the adjustment of parameters of brain stimulation in completely unrestricted subjects.

MULTI-CHANNEL TRANSDERMAL STIMULATION OF THE BRAIN

Precedents for biological transdermal stimulation may be found in the development of cardiac pacemakers (see bibliography in Glenn, 1964)¹ which stimulate the heart by using a subcutaneous coil implanted in the chest and activated by another coil placed over the skin. Stimulation of the heart is relatively simple because it requires single pulses delivered about 70 times per minute and the intensity is not critical, provided it reaches excitation threshold.

Stimulation of the brain is more complex and requires a control of electrical parameters including (a) shape of pulses, (b) pulse duration, (c) frequency (cycles per second), and (d) intensity². In addition, anatomical location of the electrodes is of decisive importance, and it is highly desirable to have access to several different cerebral areas in order to choose among functional possibilities.

Precedents for transdermal stimulation of the brain are found in Chaffee and Light³ who implanted a diode underneath the skin, and in Harris⁴ who used a subcutaneous coil activated by a very powerful

¹Glenn, W. W. L. (Ed.) Cardiac Pacemakers. Ann. N. Y. Acad. Sci., 111:Art. 3, 813-1122, 1964.

²Delgado, Jose M. R. Electrodes for extracellular recording and stimulation. Pp. 88-143 in: "Electrophysiological Methods," Vol. V, Part A: "Physical Techniques in Biological Research." N. L. Nastuk, (Ed.). New York: Academic Press, 1964.

³Chaffee, E., Leon and Richard V. Light. A method for the remote control of electrical stimulation of the nervous system. I. The history of electrical excitation. Yale J. Biol. Med., 7:83-128, 1935.

⁴Harris, G. W. The innervation and actions of the neurohypophysis; an investigation using the method of remote-control stimulation. Phil. Trans. B., 232:385-441, 1946-47.

external magnetic field. At that time, however, transistors and microelectronics were not yet available, and the methodology was rather elemental. Parameters of stimulation could not be properly controlled, and especially the intensity varied in an unpredictable way depending on the orientation of the receiving antenna, distance from the transmitter, physical configuration of the environment, and other factors. The new system described here is based on the implantation underneath the skin of a small instrument, without batteries, which is powered by transdermal reception of energy and which is able to stimulate three different areas of the brain with remote control of pulse duration, frequency, and intensity. Biological testing in monkeys has already proven the successful electronic and biological performance of the instrument. A description of its circuitry and electronic performance follows:

A. General Description

A block diagram (Fig. 1) indicates the major sections of the system and their interconnection. The control signals originate in the control circuit section (1) in the form of pulse trains of sub-carrier frequencies which amplitude modulate the VHF transmitter (2). The transmitter radiates bursts of high frequency signals containing the subcarrier information.

The modulated VHF signals are received and demodulated in the pack receiver (3). The subcarrier signal is then amplified and applied to the primary coil (4). By transformer action through the skin a voltage at the subcarrier frequency is induced in the subcutaneous coil. Depending on frequency, the signal is either used to charge a storage capacitor or to activate one of the three stimulation channels.

The design employs a pulse width modulation technique to transmit stimulation intensity information. The channel of stimulation is determined by a separate subcarrier frequency.

A harness was built for use with a chimpanzee, which carries the pack receiver, batteries and two coils. A switch is located in

the housing of the receiver, which permits the selection of one or the other coil for operation with an associated subcutaneous unit, permitting the selection of six channels of stimulation. A photograph of the harness is shown in Figure 2. The coils are molded in polyester resin which is reinforced with fiberglass cloth for protection and mounting purposes. The harness and housings for the batteries and receiver are constructed of polyethylene.

B. Circuit Description

1. Control Circuits

A picture of the control chassis is shown in Figure 3 and a block diagram of the circuitry in Figure 4. The circuit diagram is presented in Figure 5A; B; C.

The repetition rate of the stimulation signals is determined by the frequency of the astable multivibrator (a). This frequency is controlled by dual constant current transistors which discharge the cross coupling capacitors of the multivibrator at a rate set by the reference voltage from the repetition rate control (b).

The astable multivibrator triggers the monostable multivibrator (c). The ON-time of this multivibrator is controlled by a reference voltage from the intensity control (d) in conjunction with the constant current circuit which determines the discharge rate of the coupling capacitor. During the ON-time of this monostable multivibrator and AND-GATE (n) is enabled to pass the frequency signal of oscillator #1 (g) to OR-GATE (s) and from there to the driver (t). The signal from oscillator #1 provides the power for the subcutaneous part of the system. The duration of the signal determines the intensity of the stimulation pulse delivered to the electrodes as explained in paragraph 5.

At the end of the ON-time of monostable multivibrator (c) the following monostable circuit (e) is triggered by the trailing edge of circuit (b). As in the previous circuits the ON-time of this multivibrator is controlled by a voltage from the duration control (f). The output voltage of circuit (d) is connected to AND-gates (e; n and r). Depending on which of the channel ON-OFF

switches is in the ON position the signal from subcarrier oscillator #2 (k); #3 (m) or #4 (p) will be passed by one of the respective AND-gates or OR-gate (s) and thence to the driver (t). The duration of the ON-time of monostable multivibrator (d) equals the duration of the stimulus pulse from the implant and the particular subcarrier oscillator which is selected by one of the ON-OFF switches determines the channel of stimulation. The ON-OFF switches are interlocked so that only one can be ON at a time. This is required by the necessity to charge the storage capacitor in the implant before a stimulus pulse is delivered since the implant does not contain batteries which would limit its lifetime.

2. The VHF Transmitter

The circuit of the transmitter is shown in Figure 6. It consists of two transistors, a gating and an oscillator transistor. The gating transistor receives the subcarrier signals from the driver stage of the control circuits. It enables the oscillator circuit and turns it off at the rate of the subcarrier frequency. The VHF oscillator operates at a frequency of 100 MHz.

3. The Pack Receiver and Coil Driver

The circuit diagram of the receiver is shown in Figure 7. The VHF signal is demodulated in the first stage by transistor Q1. The demodulated signal is amplified in a two stage feed back amplifier with two tuned circuits in the output stage, which are stagger tuned to cover the band width from approximately 900 KHz to 2.1 MHz. The output of this pre-amplifier is coupled to a driver stage, Q4, for the output transistor Q5 which supplies power to the primary coupling coil to the implanted portion of this stimulation system.

4. The Coupling Coils

The primary coil is placed on the skin over the secondary coil which is located within the implanted part of the system. The primary coils are visible in Figure 2 as they are mounted on the harness. Figure 8 shows a picture of the side of the implant which faces the skin and therefore, the secondary coils are placed on this

side to obtain the closest proximity to the primary coil. A misalignment of one-half inch between primary and secondary coils is permissible without deterioration in performance. The larger of the two coils visible is used to supply the primary power for the implant and the smaller picks up the channel determining signals from the pack receiver.

5. The Subcutaneous Stimulator

The implanted portion of the stimulation system is assembled on two ceramic substrates which are placed back to back and encapsulated in a tissue-compatible Epoxy resin. The leads connecting the stimulator with the electrodes are extra flexible spirals covered with Sylastic. Experiments have shown that the encapsulation withstood the corrosive action of body fluids very well and have shown no signs of change or deterioration after being implanted for several months.

The first substrate carries the rectifying and impulse intensity circuitry along with the secondary coupling coils. A photograph of this substrate is shown in Figure 8 and the circuit diagram in Figure 10. The second substrate carries the gating and constant current circuitry. The photograph of Figure 9 shows this substrate and Figure 11 the circuit diagrams.

As already stated in the description of the control circuits in paragraph 1, the first pulse train to occur is used to supply power to the implanted circuitry. The signal induced into L1 by L5 is rectified by diode D1. Capacitor C1 forms a tank circuit with L1 tuned to 2 MHz, the frequency of the first signal. Storage capacitor C2 is charged through diode D3. Zener diode D2 limits the level of the DC voltage to approximately 35 to 40 volts. Capacitor C3 filters the rectified voltage. A reference voltage for the intensity network composed of C6, D5, R2 and Q1 is obtained from Zener diode D4. The diagram of Figure 12 shows the timing and wave shapes occurring at various parts of the circuit.

When a pulse train appears at L1 the leading edge of the rectified signal will, through capacitor C4, temporarily turn on transistor Q1 to remove any remaining charge from capacitor C6. As soon as Q1 is turned off, C6 begins to charge through resistor R2. Immediately after the end of the first pulse train the second pulse

train appears and depending on its frequency will be picked up by one of the tuned circuits formed by L3-C9 for channel 1; L4-C12 for channel 2 or L5-C15 for channel 3. Diodes D9; D12 or D16, respectively, will rectify this signal and after exceeding the break-down voltages of their associated zener diodes (D7; D11; D15) will turn on transistor Q2; Q5 or Q8, respectively. Either of these transistors performs two functions. It enables its corresponding constant current transistor (Q3; Q6 or Q9) and through the diode connected to its collector (D6; D10; D14) it clamps the voltage across zener diode D4 to the minus potential of the supply preventing further charging of capacitor C6. A discharge of C6 is prevented by diode D5. The bases of all three constant current transistors are connected to capacitor C6, consequently the voltage to which C6 is charged determines the current which will be passed by any of the three transistors. The voltage across capacitor C6, however, is dependent on the duration of the charging time and since the charging time is limited to the duration of the first pulse train, the intensity of the current pulse is determined by the length of the first signal.

To obtain bi-directional stimulation pulses a capacitor may be inserted in series with the output of the constant current transistors in one or more channels. A low impedance discharge path in each channel is provided by transistors Q4, Q7 and Q10. These transistors are turned on briefly by the trailing edge of the signals activating their respective channels through capacitors C8; C11 or C14, respectively.

C. Summary

An implantable stimulation system is described which enables the researcher to vary repetition rate, intensity and duration of stimulation pulses and select any one of three channels remotely. The implanted part of the system contains no batteries; power is derived from a pack carried externally by the subject. Control signals as well as power are coupled inductively to the subcutaneous unit. A combination pulse width and frequency modulation technique is employed to encode the signal information and transmit it via VHF (100 MHz) to the pack permitting unrestrained activity of the subject while stimulation

is in progress. Due to the lack of implanted batteries, the lifetime of the implant is unlimited.

A P P E N D I X

FIGURES 1 - 12

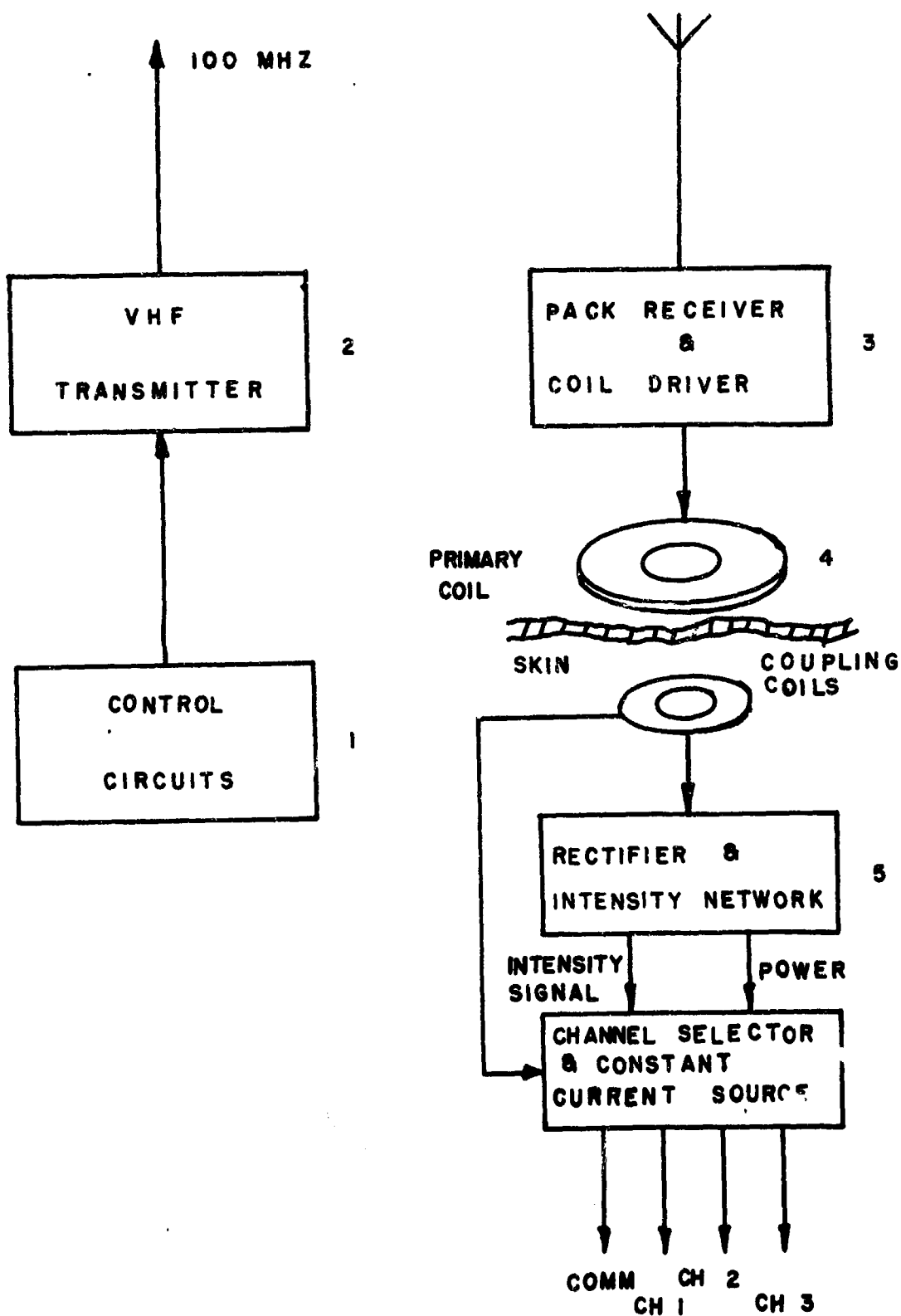

Figure 1. Block Diagram Showing the Major Sections for Transdermal Stimulation of the Brain.

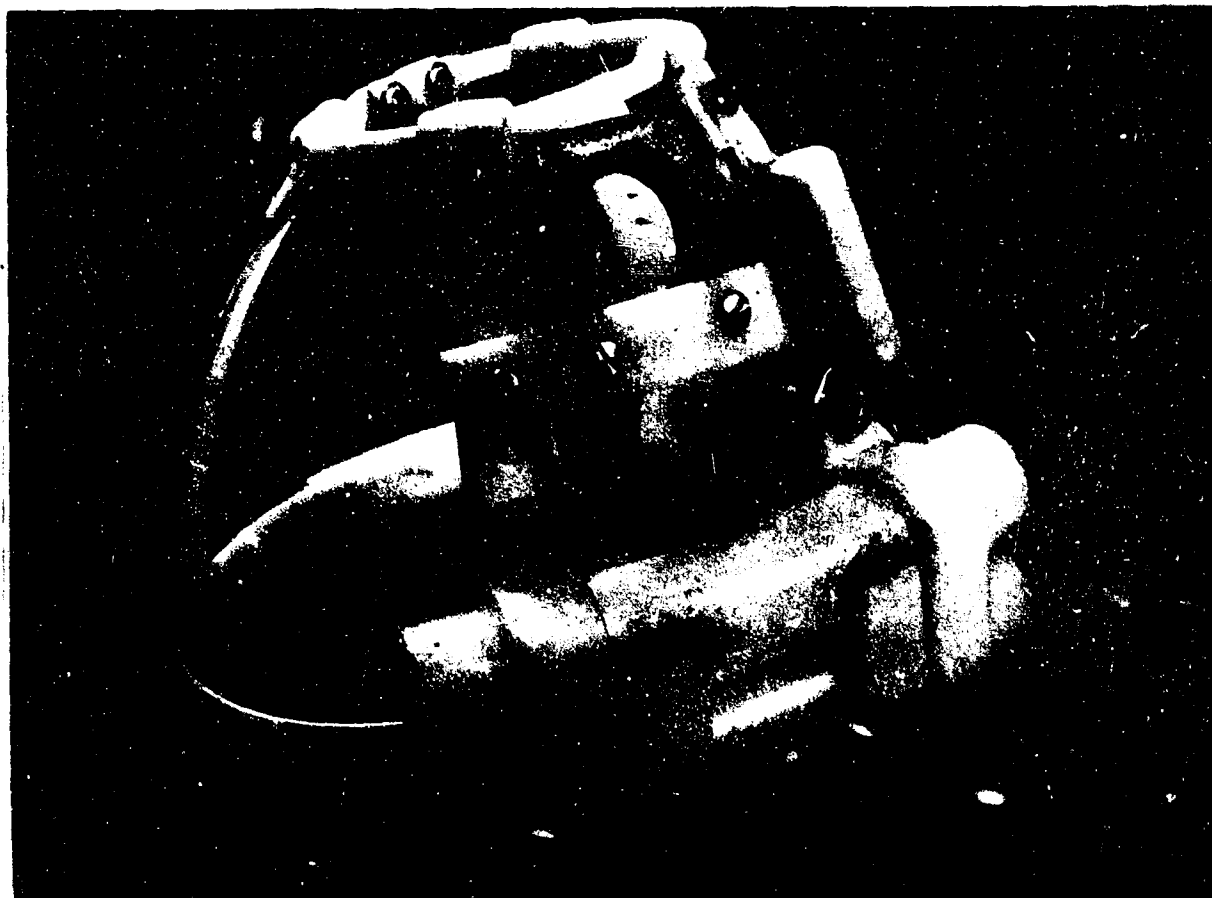

Figure 2. Harness to Attach the Pack Receiver to the Chimpanzee. (Two transdermal coils are visible in the center. The electronics for receiver and coil driver are protected by the small rectangular base shown at right. Batteries are housed in the two horizontal tubes. The batteries are large to provide long life (more than one month) without replacement).

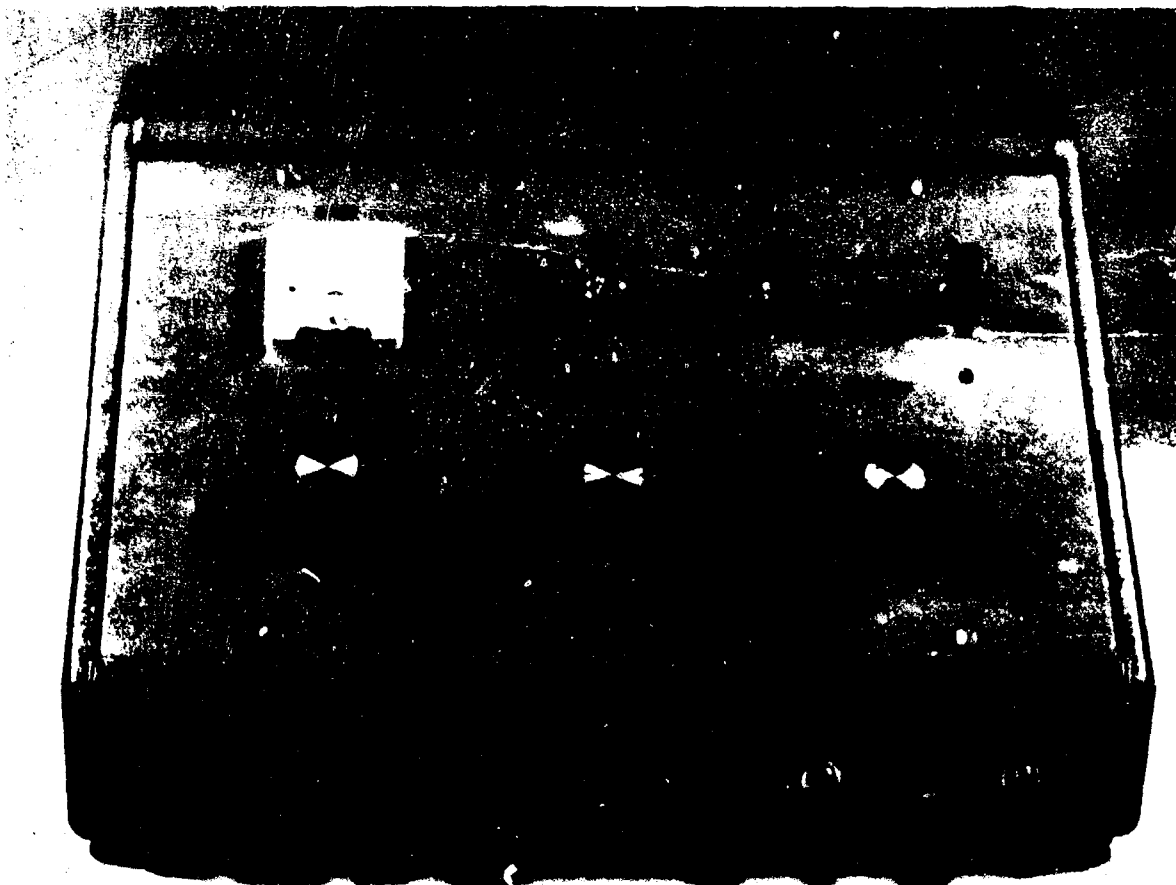

Figure 3. Control Consol Including R. F. Transmitter. (The instrument controls frequency, pulse duration and intensity in three different channels of stimulation).

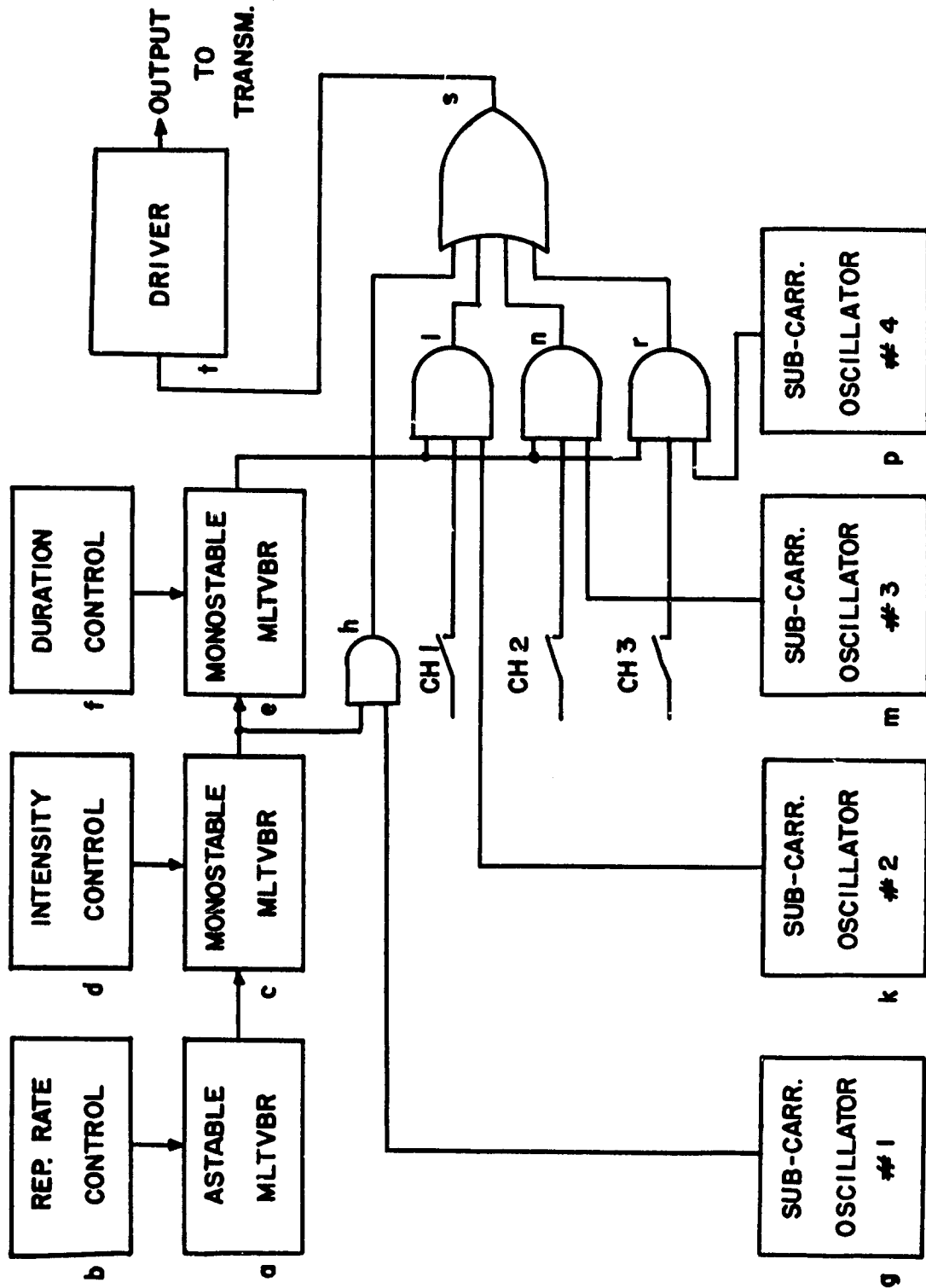

Figure 4. Block Diagram of the Control Console

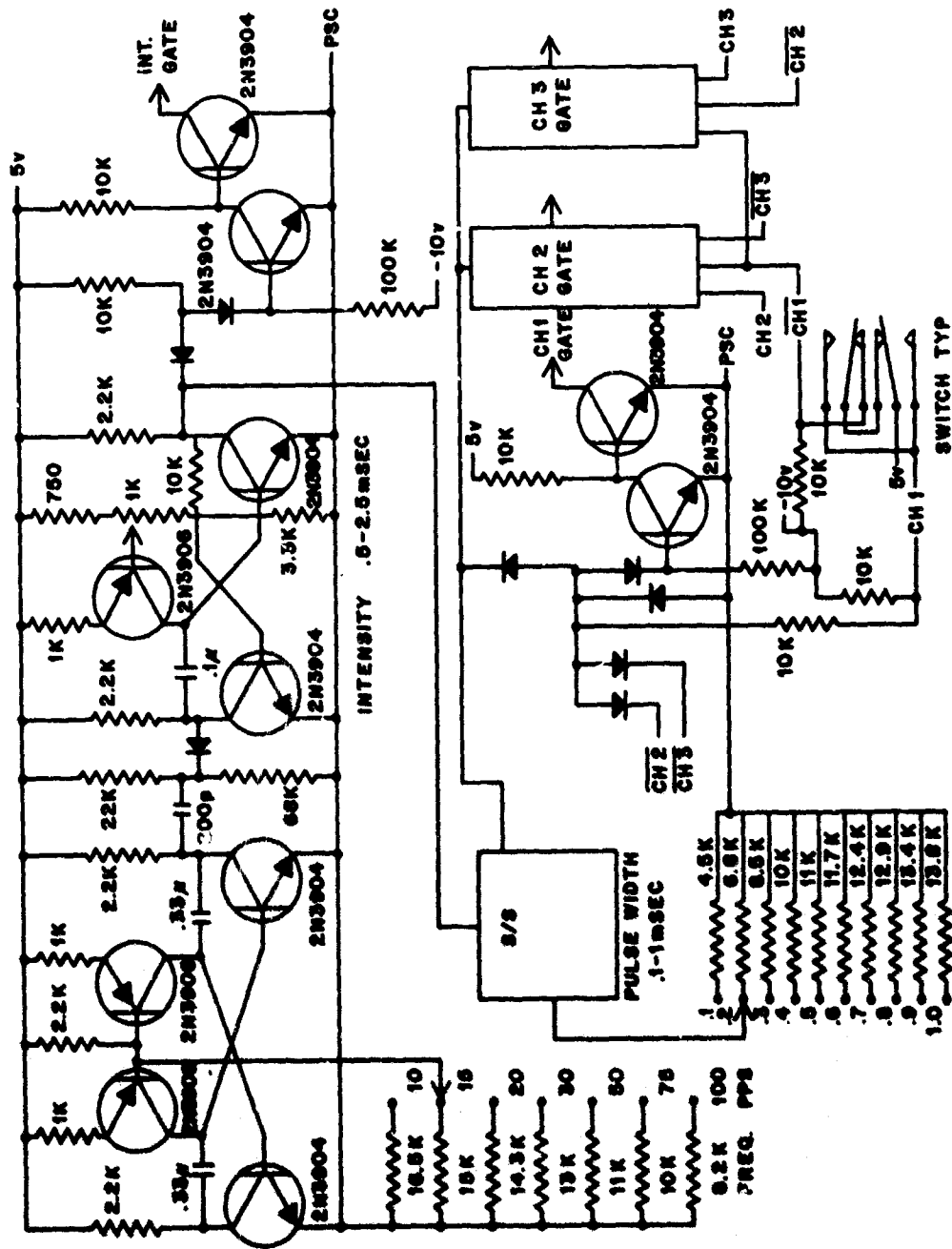

Figure 5A. Circuit Diagrams of the Control Console

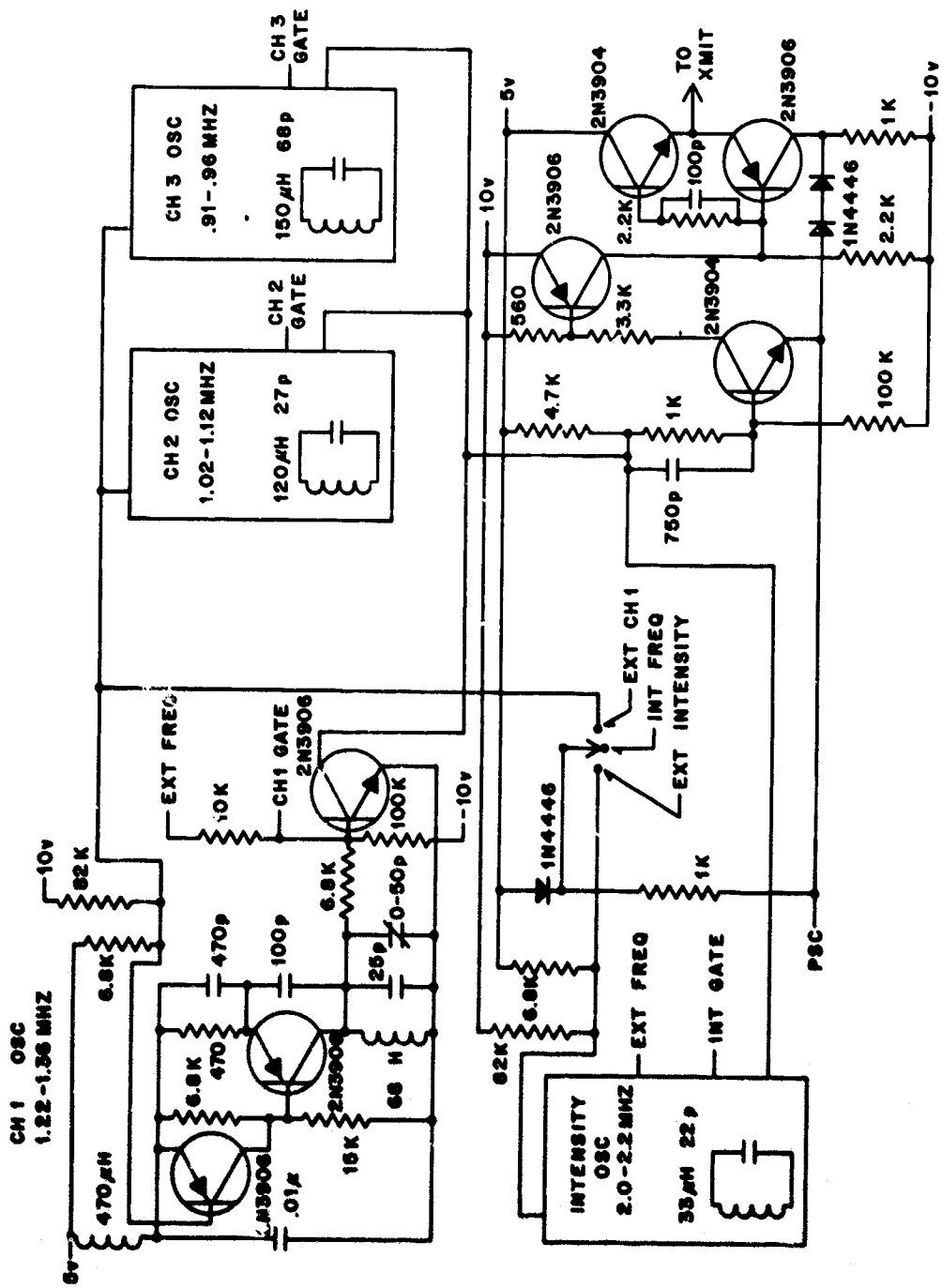
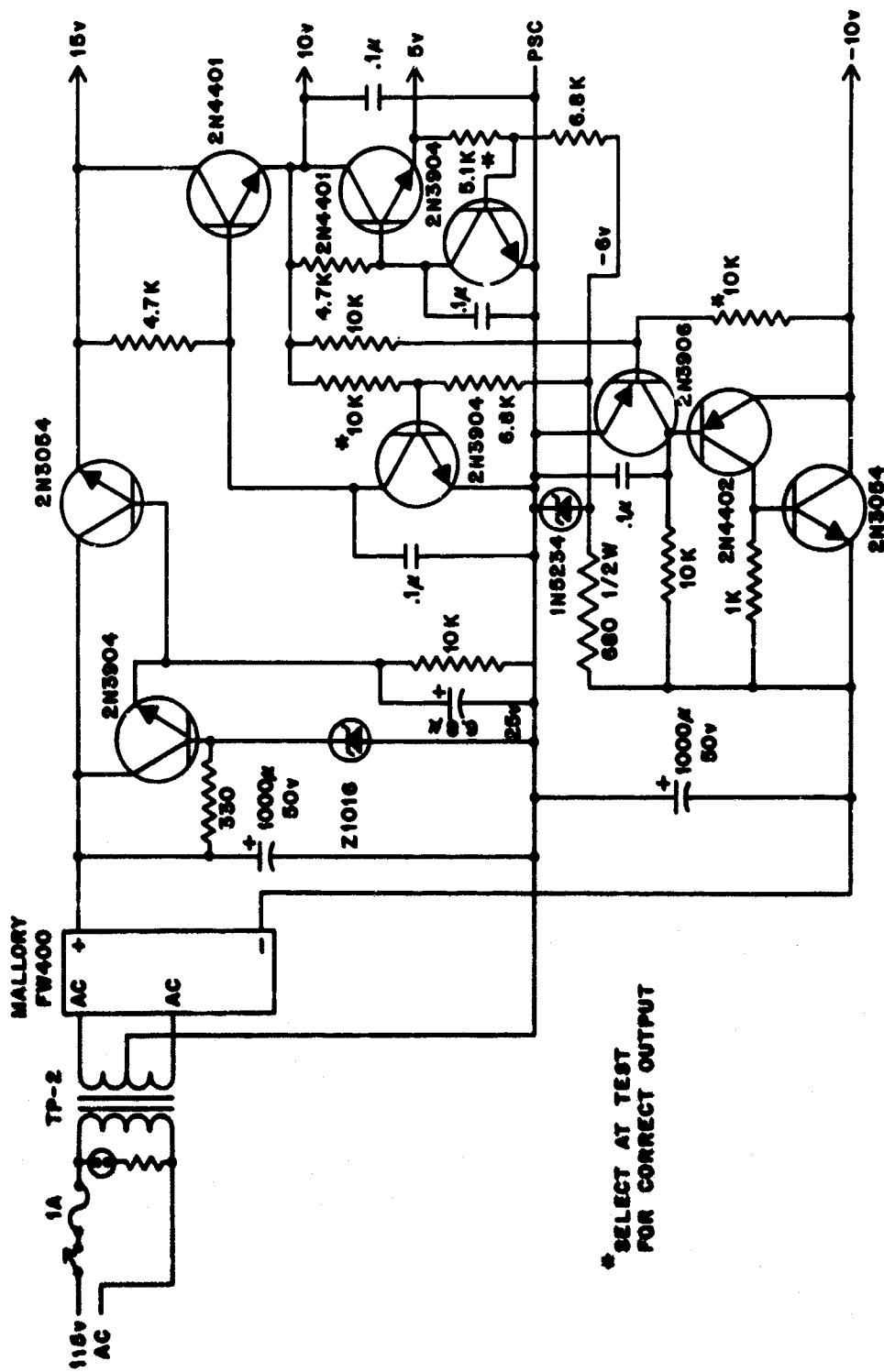

Figure 5B.--Continued



* SELECT AT TEST
FOR CORRECT OUTPUT

Figure 5C. -- Concluded.

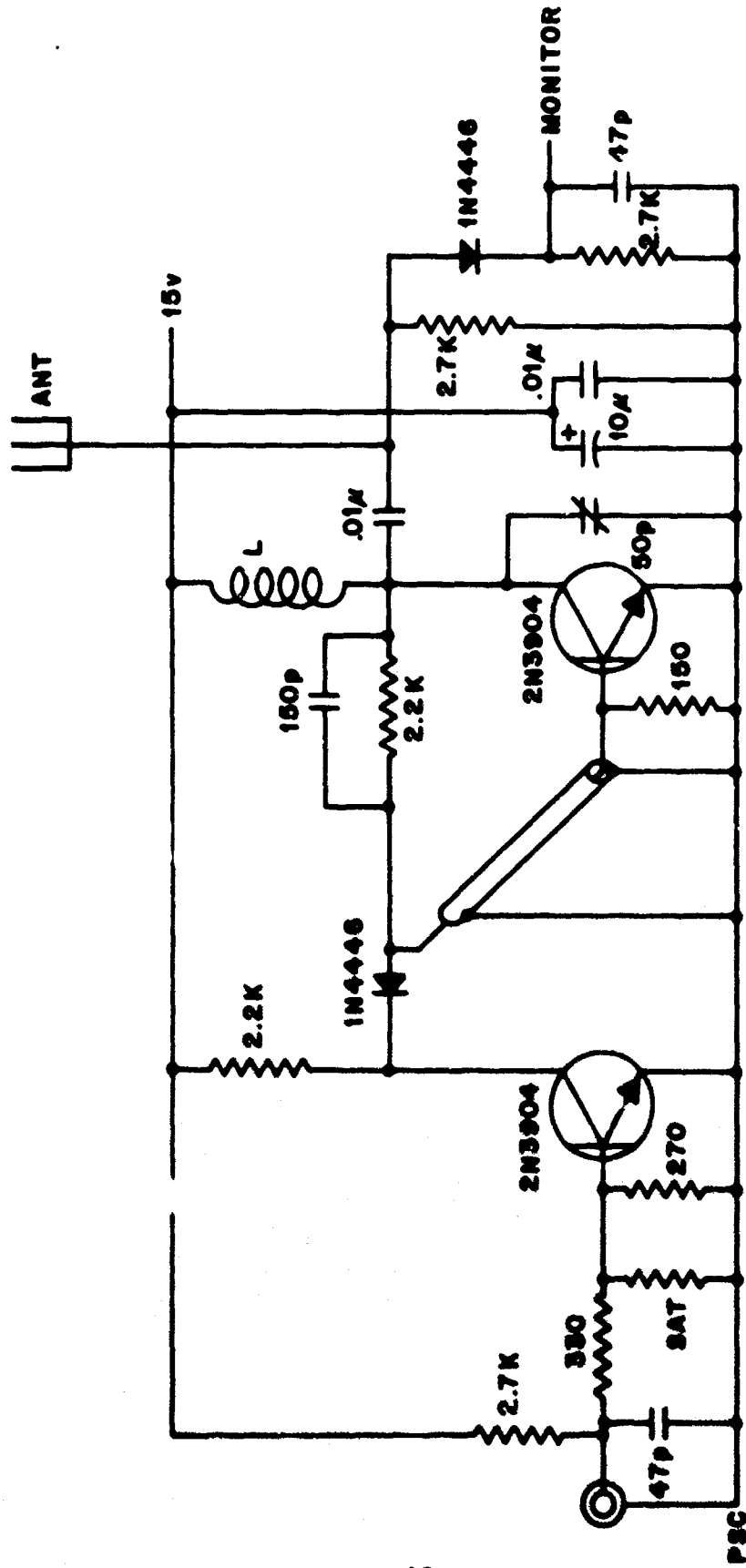

Figure 6. Circuit Diagram of the R. F. Transmitter

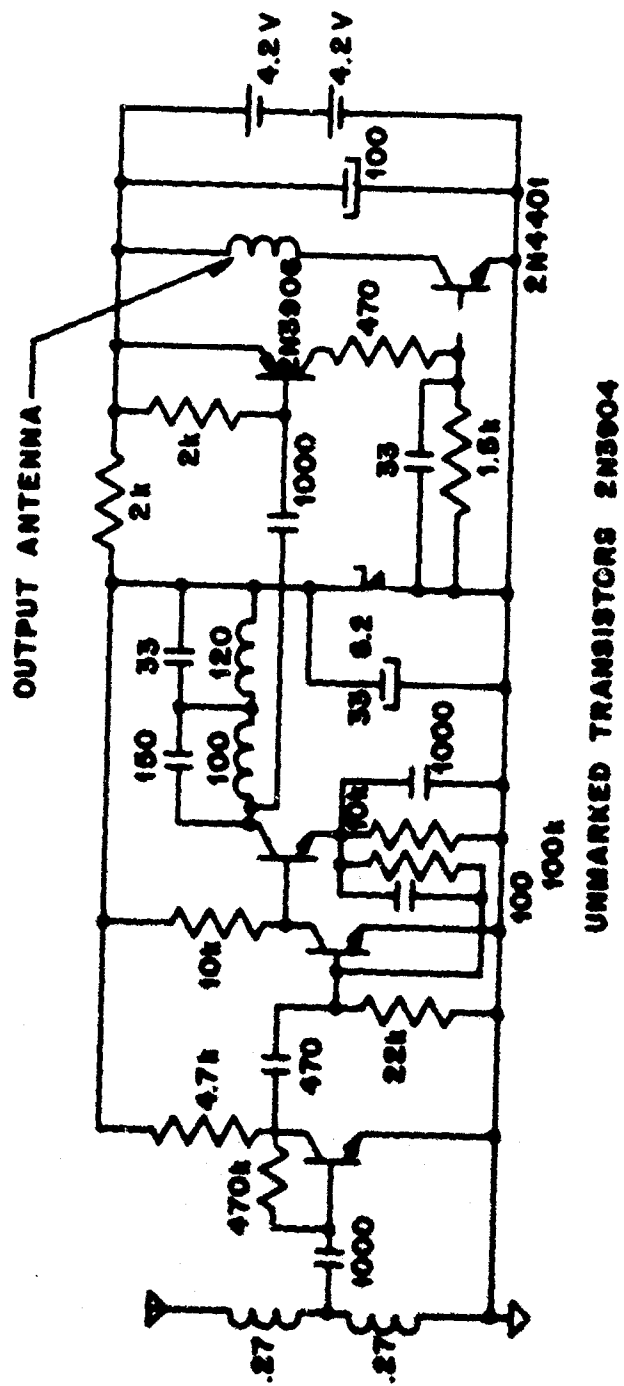

Figure 7. Circuit Diagram of the Receiver and Coil Driver.



Figure 8. Subcutaneous Stimulator Showing the Side Which Faces the Skin.

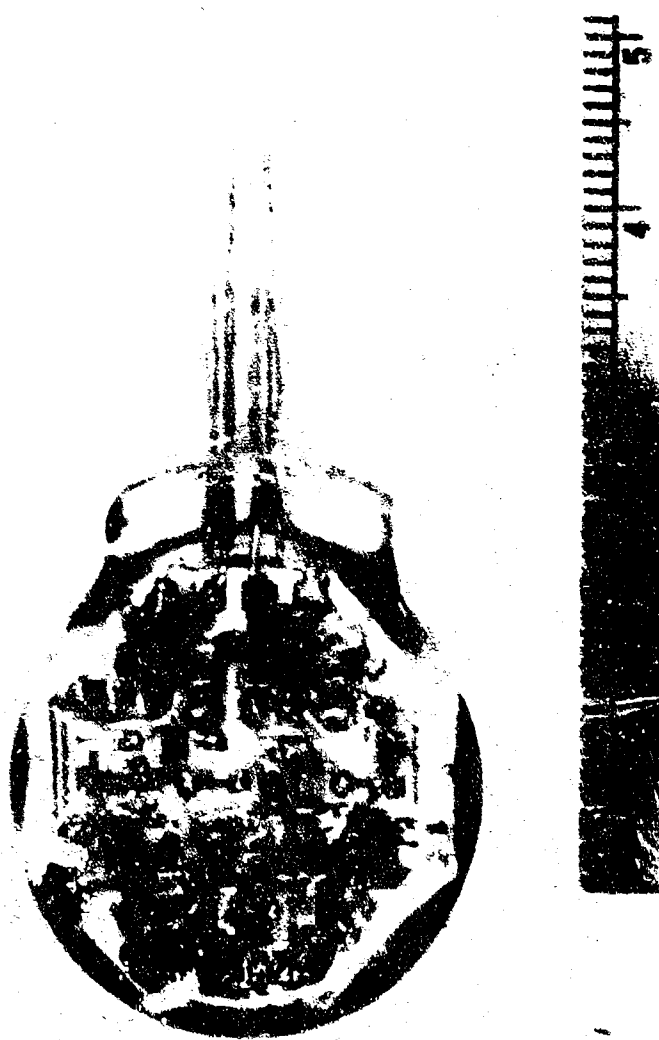

Figure 9. Subcutaneous Stimulator Showing the Reverse Side of Figure 8.
(Scale for Figures 8 and 9 is in millimeters).

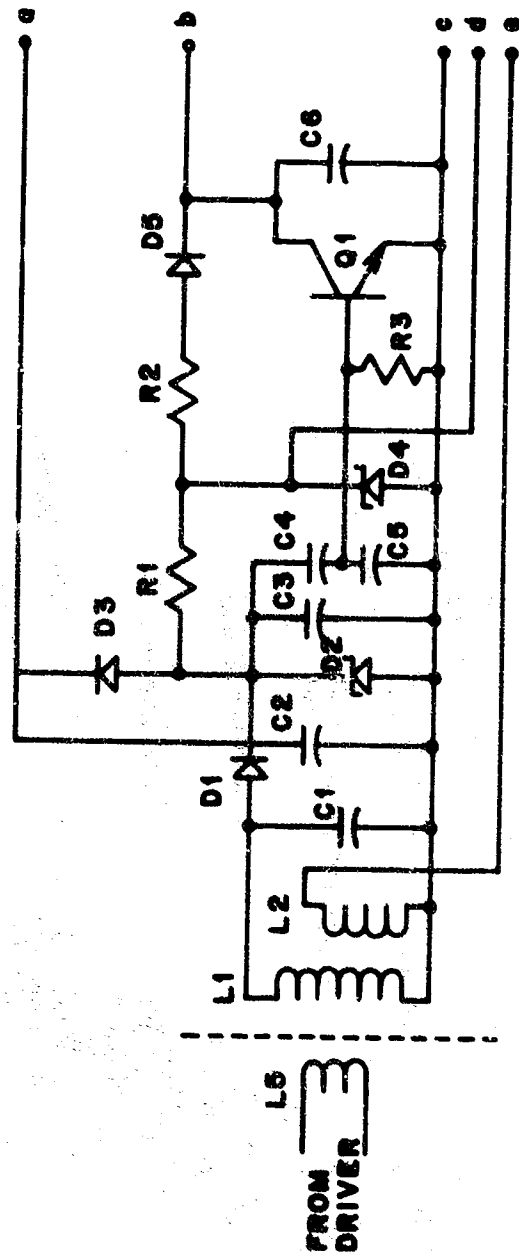

Figure 10. Circuit Diagram of the First Substrate of the Subcutaneous Stimulator.

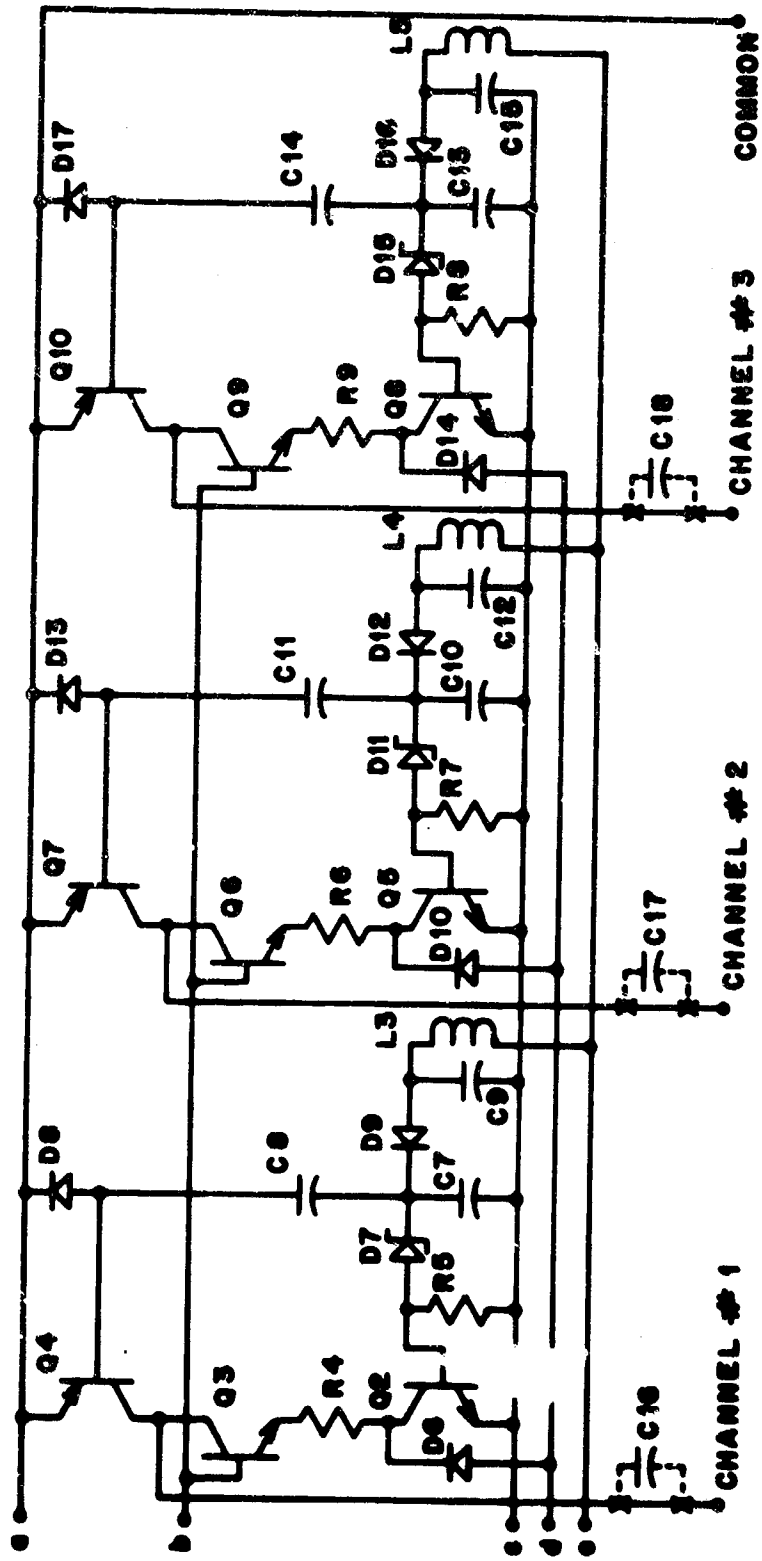

Figure 11. Circuit Diagram of the Second Substrate of the Subcutaneous Stimulator.

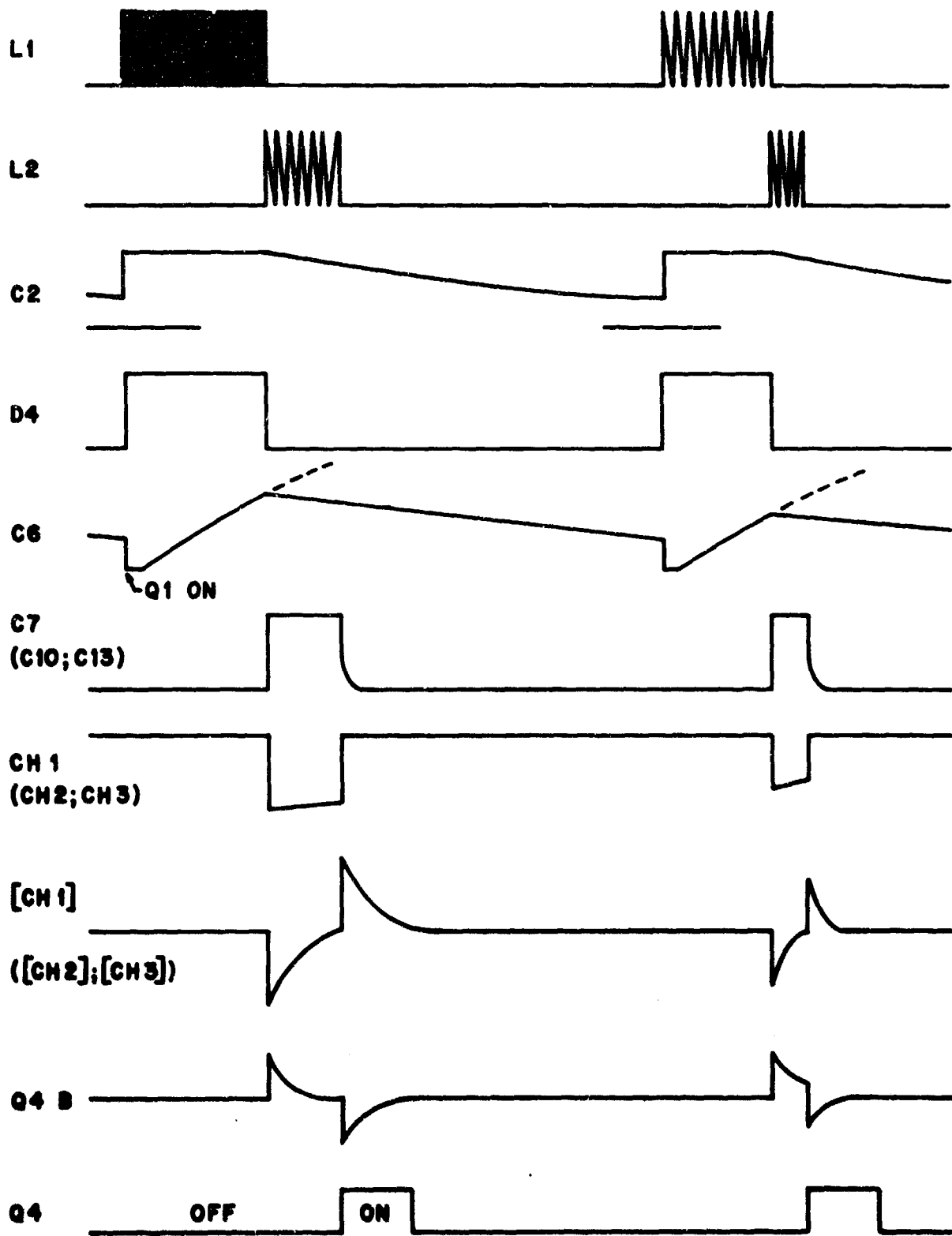

Figure 12. Waveform Diagram of Signals at Various Points in the Subcutaneous Stimulator.

Unclassified

Security Classification

| DOCUMENT CONTROL DATA - R & D | | |
|---|--|---|
| <i>(Security classification of title, body of abstract and indexing annotation must be entered when the overall report is classified)</i> | | |
| 1. ORIGINATING ACTIVITY (Corporate author) Yale University School of Medicine | | 2a. REPORT SECURITY CLASSIFICATION Unclassified |
| | | 2b. GROUP |
| 3. REPORT TITLE MULTI-CHANNEL TRANSDERMAL STIMULATION OF THE BRAIN | | |
| 4. DESCRIPTIVE NOTES (Type of report and inclusive dates) Final - 1 July 1967 - 31 December 1969 | | |
| 5. AUTHOR(S) (First name, middle initial, last name) José M.R. Delgado, M.D. | | |
| 6. REPORT DATE February 1970 | 7a. TOTAL NO. OF PAGES 24 | 7b. NO. OF REFS 4 |
| 8a. CONTRACT OR GRANT NO. F29600-67-C-9058 | 8b. ORIGINATOR'S REPORT NUMBER(S) ARL-TR-70-1 | |
| 8c. PROJECT NO. 6892 | 8d. OTHER REPORT NO(S) (Any other numbers that may be assigned this report) | |
| 10. DISTRIBUTION STATEMENT This document has been approved for public release and sale; its distribution is unlimited. | | |
| 11. SUPPLEMENTARY NOTES | 12. SPONSORING MILITARY ACTIVITY 6571st Aeromedical Research Laboratory Holloman AFB, NM 88330 | |
| 13. ABSTRACT A system has been developed for multichannel electrical stimulation of the brain through the intact skin. The stimulator which is implanted subcutaneously, has no batteries and may be used for the lifetime of the experimental subject. Power and information are provided by a small pack carried externally and activated by radio (100 MHz). A combination pulse width and frequency modulation technique is employed to encode the signal information. Three channels are available and in each, repetition rate, pulse durations, and intensity are remotely controlled, allowing the adjustment of parameters of brain stimulation in completely unrestricted subjects. | | |

DD FORM 1473
1 NOV 66

Unclassified

Security Classification

Unclassified

Security Classification

| 14. KEY WORDS | LINK A | | LINK B | | LINK C | |
|---|--------|----|--------|----|--------|----|
| | ROLE | WT | ROLE | WT | ROLE | WT |
| Brain stimulation Multichannel electrical stimulation Implanted stimulators Stimulation pulses Frequency modulation technique | | | | | | |

APPC-HOLLOWAY RFD, WASH

Unclassified

Security Classification