

AD691010

**FINAL TECHNICAL REPORT**  
**NORSAR (NORWEGIAN SEISMIC ARRAY)**  
**PHASE 1 (INSTALLATION)**

CONTRACT F 61052 - 68 - C - 0009

SPONSORED BY

ADVANCED RESEARCH PROJECT AGENCY

ARPA ORDER NO 800

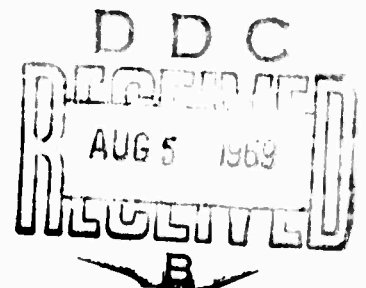

**FORSVARETS FORSKNING SINSTITUTT**

Norwegian Defence Research Establishment

Postboks 25 - Kjeller

Norge

This document has been approved for public  
release and sale; its distribution is unlimited

**BEST  
AVAILABLE COPY**

LEGAL NOTICE

When US Government drawings, specifications or other data are used for any purpose other than a definitely related government procurement operation, the government thereby incurs no responsibility nor any obligation whatsoever; and the fact that the government may have formulated, furnished, or in any way supplied the said drawings, specifications, or other data is not to be regarded by implication or otherwise as in any manner licensing the holder or any other person or conveying any rights or permission to manufacture, use, or sell any patented invention that may in any way be related thereto.

OTHER NOTICES

Do not return this copy. Retain or destroy.

ADDITIONAL FOR	
CFSTI	WHITE SECTION <input checked="" type="checkbox"/>
DDC	DUHF SECTION <input type="checkbox"/>
UPA NOUNCED	<input type="checkbox"/>
JUSTIFICATION	
BY	
DISTRIBUTION AVAILABILITY CODES	
DIST.	AVAIL. CODES OR SPECIAL
?	

CONTRACT No F61052-68-C-0009

21 October 1968

TECHNICAL REPORT

NORSAR (NORWEGIAN SEISMIC ARRAY)  
PHASE 1 (Installation)

NORWEGIAN DEFENCE  
RESEARCH ESTABLISHMENT  
N-2007 KJELLER - NORWAY  
INTERN RAPPORT S-37

ARPA Order No: 800

Program Code No: 7F10

Name of Contractor : Norwegian Defence Research Establishment,  
N-2007 Kjeller, Norway

Date of Contract : 23 August 1967

Amount of Contract : \$ 860 200, -

Contract No : F61052-68-C-0009

Designator : Project NORSAR

Contract Termination Date : 30 September 1968

Project Supervisor : F Lied, Director NDRE

Project Leader : Ø Brandtzæg, Captain, NDRE

Title of Contract : "Norwegian Seismic System, Phase I"

## FOREWORD

This research installation project is sponsored and supported by the Advanced Research Projects Agency of the Department of Defense. The Electronic Systems Division (AFSC) technical project officer for Contract No F61052-68-C-0009 is Major Nicholas A Orsini (ESUH). Contractual support was provided by the European Office of Aerospace Research, OAR. This report covers the period from May 1967 through January 1968.

We wish to acknowledge the very considerable support and assistance provided during the course of this project by the Nuclear Test Detection Office (ARPA), the Seismic Array Program Office (ESD), the Air Force Office of Scientific Research (OAR), the Lincoln Laboratory (MIT), the Education and Technical Services Division of the Philco-Ford Corporation and Geotech, a Teledyne Company.

This technical report has been reviewed and is approved.

WILLIAM R LAUTERBACH, Lt Col, USAF  
Chief, Seismic Array Program Office  
Development Engineering Division  
Directorate of Planning & Technology

CONTENTS

		Page
1	INTRODUCTION	5
1.1	Seismic detection of underground nuclear weapons tests	5
1.2	Project NORSAR, a LASA in Norway	5
2	PLANNING	7
2.1	Sites requirements	7
2.2	Preliminary siting	8
2.2.1	Subarray site	8
2.2.2	Site for the noise study array	10
2.2.3	Site for third LP station	12
2.3	Array patterns, detailed siting	12
2.3.1	Subarray pattern	12
2.3.2	Noise study array pattern	13
2.3.3	LP array pattern	15
2.4	Drilling and casing, requirements and domestic capacity	15
2.5	Well head vault	
2.6	Seismic signals transmission within sites	17
2.6.1	Trenching	17
2.6.2	Seismic signal cables	19
2.7	LP vault	20
2.8	Housing of the signal acquisition systems	21
2.8.1	Temporary housing of the DRCs	21
2.8.2	Central terminal vault	28
2.9	Power supplies	29
2.9.1	Power supply for the Øyer DRC	29
2.9.2	Power supplies for Falldalen and Borgseter DRCs	31
2.10	Telecommunications	31
2.10.1	Telecommunications for Øyer DRC	31
2.11	Instrumentation	32
2.11.1	Øyer SP subarray	32
2.11.2	LP array	35
2.11.3	Experimental noise study array	43
3	INSTALLATION	44
3.1	Subcontracting	44
3.1.1	Services	45
3.1.2	Materials	46
3.2	Drilling and casing of boreholes	47
3.2.1	General techniques	47
3.2.2	Progress of work	51
3.2.3	Special problems and experiences	51
3.3	Well head vaults installation	52
3.3.1	Production and delivery of vaults and vault electronic equipment	52
3.3.2	Installation of the vaults, retainer rings and covers (coolie hats)	52

	Page	
3.3.3	Installation of amplifier and junction boxes - signal cables connection	52
3.4	Trenching	53
3.4.1	General techniques	53
3.4.2	Progress of work	54
3.4.3	Special problems and experiences	54
3.5	Cable delivery, laying and splicing	55
3.5.1	General procedures and techniques	55
3.5.2	Progress of work	56
3.5.3	Special problems and experiences	56
3.6	LP and CT vaults	56
3.6.1	General techniques	56
3.6.2	Progress of work	58
3.7	Data recording centres	58
3.7.1	Øyer DRC	63
3.7.2	Falldalen DRC	67
3.7.3	Borgseter DRC	69
3.8	Instruments installation and check-out	69
3.8.1	Installation	69
3.8.2	Calibration and check-out of SP system at Øyer	71
3.8.3	Calibration and check-out of the LP systems	72
4	CONCLUDING REMARKS	73
4.1	Land acquisition problems	74
4.2	Siting of vaults and boreholes	74
4.3	Problems in connection with construction and technical installations	75
 APPENDICES		
A1	REPORTS AND EXCERPTS OF REPORTS ON SEISMOLOGY AND GEOLOGY	75
A2	CABLE SPECIFICATIONS AND TESTING	94
A3	SEISMOMETER AND WHV CIRCUITRY SPECI- FICATIONS AND WIRING DIAGRAMS	97
A4	DATA CONCERNING BOREHOLE DRILLING	109
A5	SOME DATA CONCERNING THE POWER SUPPLY AT ØYER	136



## NORSAR (NORWEGIAN SEISMIC ARRAY), PHASE 1 - INSTALLATION

### ABSTRACT

Project NORSAR (Norwegian Seismic Array) comprises planning, installation and operation of a large seismic array in the south-eastern part of Norway. When completed, the array will consist of a large number of short-period (SP, 1 Hz) and long-period (LP, 0.05 Hz) seismometers distributed in a certain pattern and centrally wire-connected to a Data Processing Centre, where detection and analysis of seismic events will take place.

As a first step, Phase 1 comprises installation of one SP sub-array containing some 20 seismometers, a rudimentary LP array consisting of 3 three-component sensors, and a small experimental noise study SP array with some 5 - 7 sensors. The instrument signals are analog/digital converted and recorded on magnetic tape at the sites.

Subsequent to a brief introductory history of project NORSAR, this report describes the planning and implementation stages and presents the technical data of Phase 1.

## 1 INTRODUCTION

### 1.1 Seismic detection of underground nuclear weapons tests

During previous years great efforts have been made in various quarters to lower the levels of detection and identification of underground nuclear weapons tests, the seismic signals from which compete with earthquake signals and noise from different origins. The purpose of this work is to assist in the formulation of a basis for an extension of the partial Test Ban Treaty of 1963, which does not include underground tests.

The main tendency during this period has been a shift from a system of many small and well dispersed seismic stations towards one consisting of a few large stations, each forming a local array of centrally connected seismometers. The latter system has definite advantages as to noise suppression and localization capabilities. This trend brought about the installation of the Large Aperture Seismic Array (LASA) in Montana, USA. When inaugurated in 1965 LASA consisted of 525 seismometers grouped in 21 subarrays of 25 sensors each, within a circle of diameter approximately 200 km.

### 1.2 Project NORSAR, a LASA in Norway

Operation of LASA has answered many questions and largely fulfilled expectations. It cannot tell unambiguously, however, how the large station concept works in a

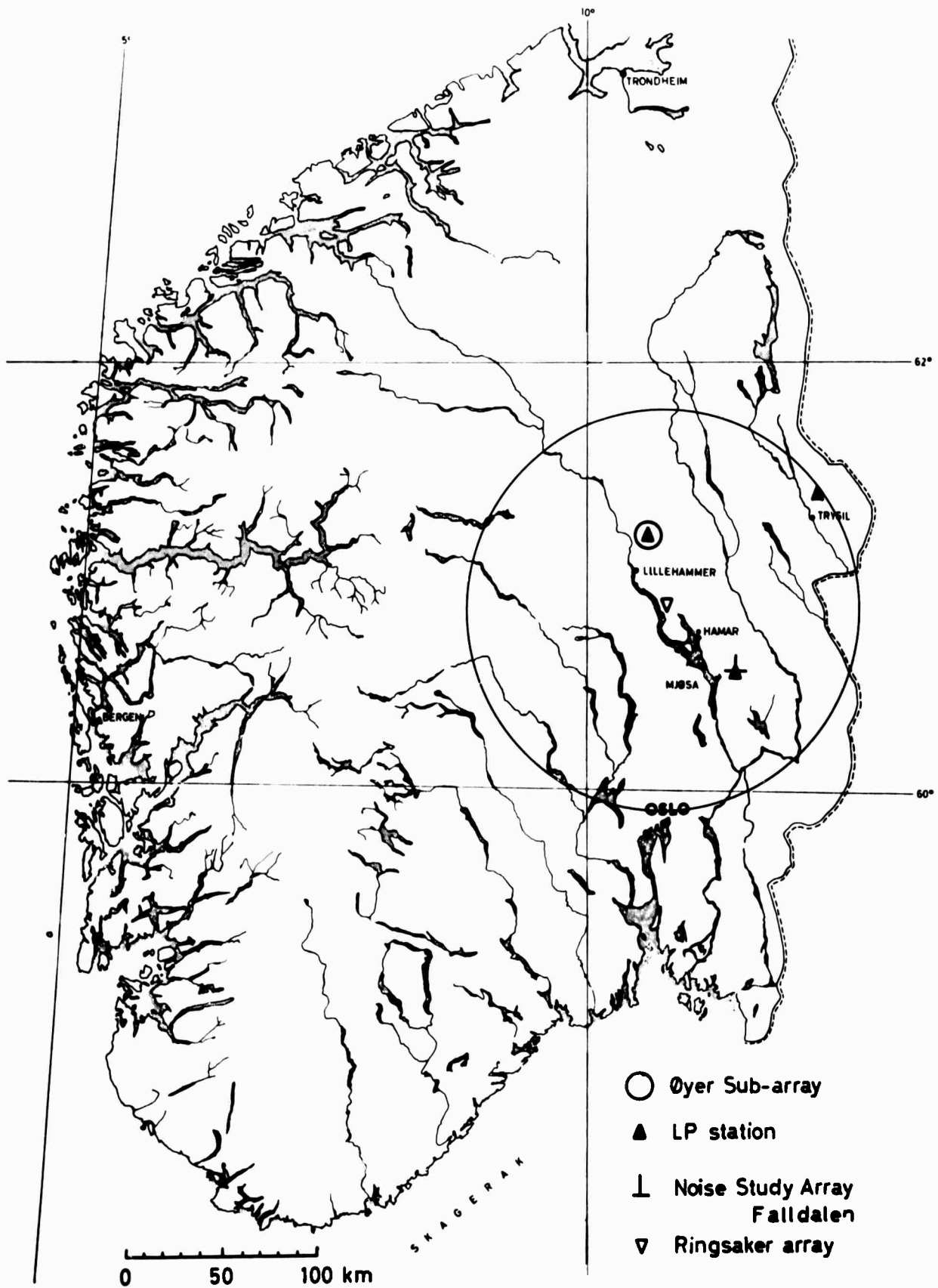

Figure 1.1 Southern Norway  
Circle indicates general area of interest.

widely different geographical and geological area. Furthermore, other stations are necessary when benefits of collaborating stations are to be investigated.

Installation and operation of a large seismic array in the south-eastern parts of Norway (Figure 1.1) was formally proposed in May 1967 by the Advanced Research Projects Agency (ARPA), which had also been responsible for project LASA.

For obvious reasons detailed plans for the array were not ready when the proposal was put forward, but one had in mind a system somewhat smaller than LASA with respect to physical size, but probably about equal in detection capability.

It was also suggested that the installation should be divided into two phases. Phase 1 would cover installation of one subarray of about 20 short period (SP-1 Hz) seismometers in boreholes, a rudimentary array consisting of three long period (LP-0.05 Hz), three-component seismometers, and a small experimental (noise study) Array (XA) with 5 - 7 SP seismometers. The analog signals from the seismometers would be converted and recorded digitally on magnetic tape. The SP seismometers would be placed in vertical holes drilled in bedrock, while the LP sensors would be put inside concrete vaults, the floors of which are cemented to bedrock. It was assumed that Phase 1 would be completed during 1967.

Phase 2 would cover the remainder of the large array, i.e. installation of 5 - 10 SP subarrays and an LP array with 20 three-component sensors, to be installed during 1968-69.

The Norwegian Government expressed positive interest in the proposed project and gave a qualified consent to Phase 1 in June 1967. It was agreed that the Norwegian Defence Research Establishment (NDRE) would be the Norwegian contractor, that the Electronic Systems Division (ESD), USAF, would act for ARPA as Technical Program Director and that the European Office of Aerospace Research (EOAR) would function as the US Contracting Agent, Lincoln Laboratory (LL) of the Massachusetts Institute of Technology (MIT) would serve as technical consultant together with personnel from Philco-Ford Corporation, an LL subcontractor.

## 2 PLANNING

It was evident from the very beginning - when the first contact was made in May - that time was very short if Phase 1 installations should have any chance of being completed by the end of 1967. All non-committal investigations and planning had to start immediately and continue while government-to-government agreement and contract negotiations were still under way. In fact, most of the preparatory work including planning down to some detail had been done when initial project funding opened the implementation stage in late August.

### 2.1 Sites requirements

Three sites were needed for Phase 1 installations, as defined in 1.2.

As first presented by ARPA, the primary one of many requirements for the subarray (SA) site was to have a circular area of 15 - 20 km diameter, free of cultural noise. In this area, 20 SP seismometers in rock boreholes would be evenly distributed and wire-connected to a Data Recording Center (DRC). This stipulation ruled out populated areas, in which man-generated seismic noise and land acquisition for boreholes and interconnecting cables would cause problems. It was considered important that the site could be fitted into the large array pattern to be realized in Phase 2.

The experimental array called for a much smaller area, defined by a cross-like pattern, with arm lengths of the order of 2 and 4 km, the distance between individual seismometers being 1 - 3 km. Except for housing and other means of general support, all equipment for the XA would be brought in by LL in order to have the array operational at the earliest possible date. To avoid seismic disturbances from installations at the subarray, and also to accumulate information on noise characteristics at another site within the general area (south-eastern Norway), the XA would most profitably be sited at some distance from SA. Otherwise the requirements were identical to those of the SA site.

The distance between LP sensors (three component) should at least be of the order of 25 km, preferably more. Since these interspaces between sensors precluded use of a common tape recorder for all LP sensors, each sensor would need its own recorder. For reasons of economy and convenience the natural thing to do would be to collocate two of the LP sites with the DRCs of SA and XA, so that the corresponding LP recorders shared housing with the SA and XA recorders. The third LP site would have its own housing.

It was anticipated that the time spent on land acquisition in private ownership areas would be prohibitive, hence it was decided to give strong preference to common land, either state-owned or owned by a local community.

## 2.2 Preliminary siting

Air photographs and maps covering topography, land ownership, population density and communications were used for a first selection of potential sites. This was followed by a brief inspection from the air and visits to the areas of interest. In addition to criteria already mentioned, the suitability of each area was also judged with respect to its geology (bedrock characteristics and depth of overburden), the existence of local noise sources of natural or artificial origin, and the conditions for connecting the DRCs to commercial power and to the telecommunication network of the Norwegian Telegraph Administration (NTA). As a result of studies along these lines, three sites were picked out for detailed investigations.

### 2.2.1 Subarray site

A mountain plateau some 25 km NNE of the small town of Lillehammer (Figure 1.1) and within the municipality of Øyer seemed in most respects to be a suitable place for the subarray. The plateau is comparatively even by Norwegian stan-



Figure 2.1 Øyer mountain plateau, typical terrain



Figure 2.2 Gudbrandsdalen valley, Øyer mountains to the right

dards (Figure 2.1), the major part of it being within the height range 900 - 1000 meters above sea level (masl). No ridges or valleys of significance cross the area; it is, however, bordered in the WSW by Gudbrandsdalen valley, a major valley with steep sides and a bottom level less than 200 masl (Figure 2.2), i.e. introducing a height difference of 700 - 800 m.

The area has no permanent population, but a small number of huts are situated on the outskirts and it serves as a recreation ground for campers, anglers and hunters for periods during summer and fall, and for skiers during winter and spring. Utilitarian use of the ground does not go beyond a little mountain farming (cattle grazing) during the summer, and occasional daily transportation of a few timber loads along roads peripheral to the area.

Geologically the area is characterized by eocambrian bedrock (Figure 2.3) covered by glacial moraine deposits to depths ranging from zero at a few outcrops to some ten meters at most, (see Appendix 1, excerpts of reports from geology consultants).

The major part of the area is above the timber-line and has a sparse vegetation of lichen, mosses and low bushes. There are a number of small lakes and brooks, none of which were considered unacceptable sources of seismic noise.

Much importance was attached to the fact that most of the plateau was within common land owned by the State.

Remoteness from the NTA telecommunication network and to commercial power supply constituted the major drawbacks.

#### 2.2.2 Site for the noise study array

On community-owned common land, and originally inspected as an alternative site for the subarray, the area surrounding Falldalen, a small valley about 12 km east of Tangen railway station by Lake Mjøsa (Figure 1.1), was picked as a seismically acceptable and otherwise very convenient place for the noise study array (XA). Roughly two hours by road from Oslo (LL & Philco HQ) and Kjeller (NDRE), this site offered relatively easy access, a valuable asset for an experimental installation demanding technical rearrangements at short notice.

This area differs considerably from the one at Øyer. It is a lowland (average 300 masl) and hilly area (Figure 2.4) covered with spruce forest. It is sparsely populated, but the forest is well utilized and thus introduces various activities connected with lumbering. However, it was not considered that these activities would be too noisy or otherwise interfere unduly with the operation of the array.

The bedrock is granite (Figure 2.3), mostly with a thin mould cover, but also with areas of marshland. It was assumed that the existence of a number of small lakes and brooks would not contribute excessively to the local noise level.

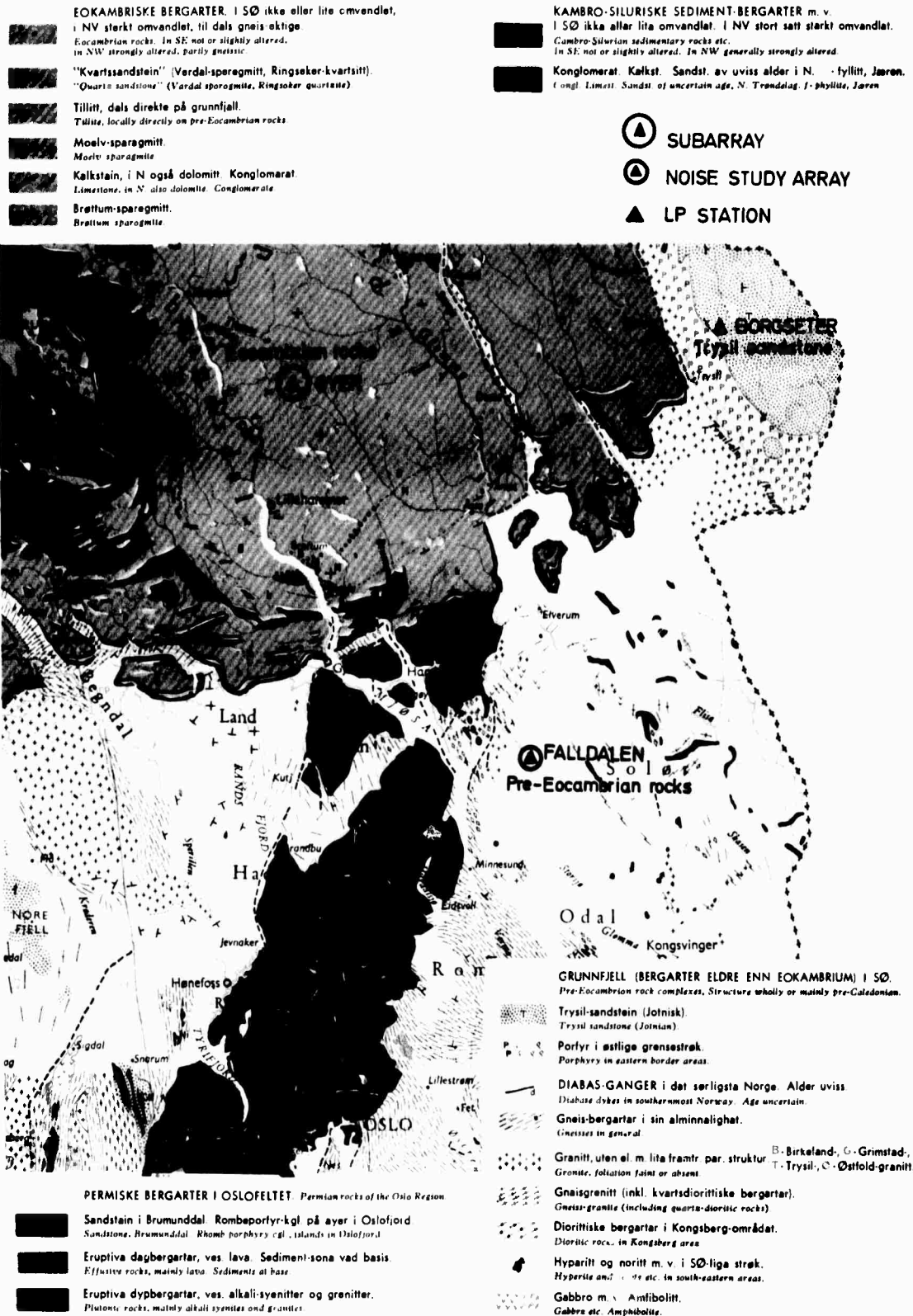

Figure 2.3 Bedrock geology, south-eastern Norway



Figure 2.4 Falldalen, typical terrain

#### 2.2.3 Site for third LP station

As a result of visits to several potential places within the general large array area, a site for the third LP-station was found near Borgseter, some 8 km NE of Trysil (Figure 1.1) and within the borders of state-owned land. Except for being less hilly and in general with a deeper overburden of glacial deposits, the area was in most respects similar to the Falldalen district.

### 2.3 Array patterns, detailed siting

#### 2.3.1 Subarray pattern

The final and accurate positioning of each SP seismometer was a multi-step procedure characterized by compromises between conflicting interests.

A minimum distance of about 3 km was stipulated between neighbouring seismometers. This figure was based on a preliminary analysis of noise correlation versus distance at an existing array at Ringsaker (Figure 1.1 and Appendix 1.1).

A maximum distance of about 4 km was primarily determined by limits set by the extent of the plateau and the borders of the common land area, but also economical considerations would probably have produced a similar value.

The pattern itself decides the directional response function of the seismic "antenna" constituted by the array. However, at the present state of knowledge there is no generally accepted optimum pattern of universal validity, at least not when taking



into account the uneven and partly unknown global distribution of noise and event sources. Therefore, when the directivity response of each potential pattern was determined by means of an LL computer program, the result was the elimination of evidently unsuitable patterns rather than a search for the best one.

Some regular patterns lend themselves better for efficient data processing. However, when tested on the map or in the field, practical obstacles in the form of lakes, brooks, marches, thick moraine deposits, difficult access etc will impose shifts away from regularity.

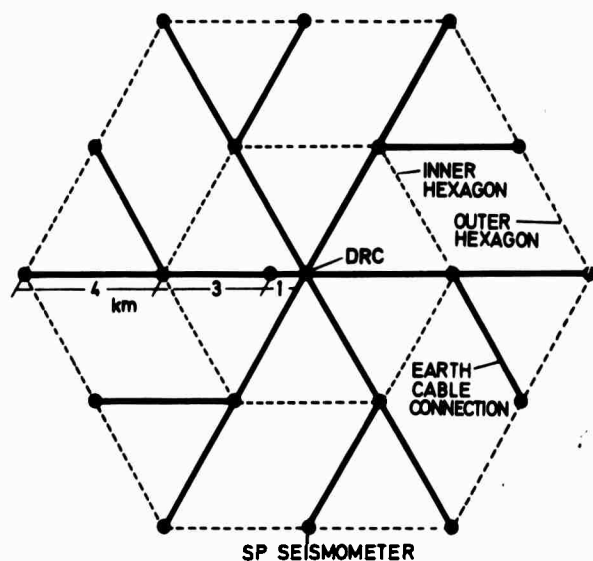

Figure 2.5 Basic hexagonal pattern, Øyer subarray

After having considered several possibilities, one settled for a basically hexagonal pattern for the Øyer subarray. This pattern consists of an inner hexagon containing 6 seismometers and, concentric to this, an outer hexagon having 12 seismometers, the unit distance between them being 4 km. Together with a centre seismometer and an extra seismometer (enabling local noise correlation study) approximately 1 km off-centre, the array would contain 20 seismometers (Figure 2.5).

Following map derived repositioning as described above, third approximation adjustments in the field

were based on geological estimates and also some seismic soundings (consultant's report, Appendix 2) to select points with acceptable depths to bedrock.

Discussions on optimum siting of the DRC suggested two alternatives. A DRC at the SSW rim of the array (Figure 2.6) would secure shorter power and telecommunication cable connections and easier access to the DRC from the valley, whereas the main benefit of a central DRC was economy in signal cable connections between individual SP seismometers and the DRC. Another argument in favour of placing the DRC centrally was the seismically more suitable site obtained for the adjoining LP installation. In a sum, the arguments for the latter proposition were found to be the most convincing. The subarray configuration is shown in Figure 2.6.

### 2.3.2 Noise study array pattern

Originally proposed as two single seismometers in boreholes, the noise study array eventually evolved into an L-shaped and finally a T-shaped pattern of five seismic points. Each point would have one shallow hole formed as a casing of length about 1.5 m, cemented to a hole blasted in rock. Two of the seismic points would in addition be fitted with a 60 m deep cased borehole.

The criteria for positioning of the individual seismic points were largely similar to

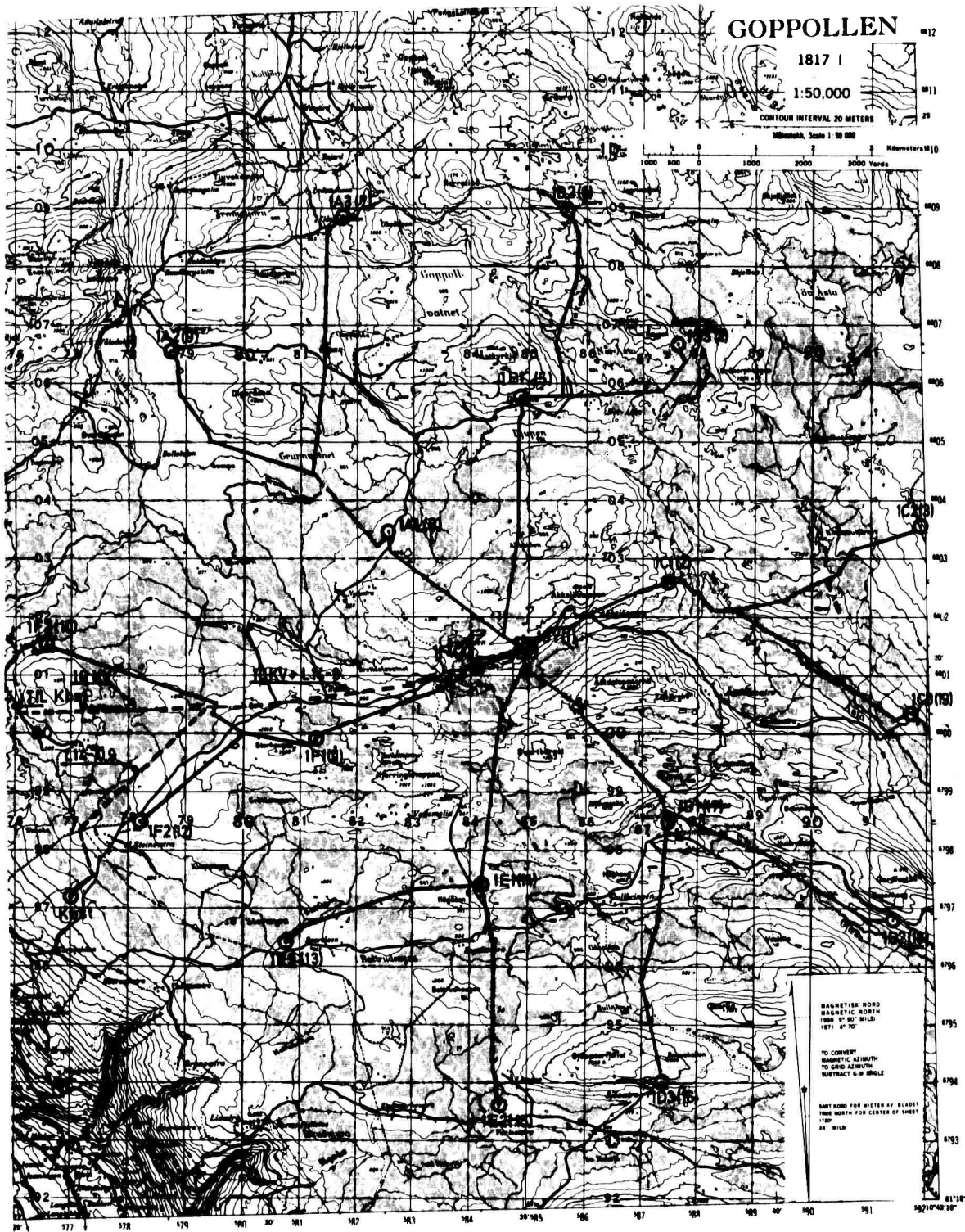

Figure 2.6 Over subarray configuration

those used at Øyer. However, the very tight time-schedule stipulated for the installation of the array made it necessary to give extra preference to sites having easy access. In the rather hilly and densely wooded area around Falldalen this was tantamount to choosing places quite close to roads or at least to cart tracks, to facilitate the tasks of bringing in construction equipment and laying surface cables between the seismic points and the DRC. Figure 2.7 shows the final configuration of the noise study array.

### 2.3.3 LP array pattern

The general pattern of the LP array was already established as a result of the preliminary siting discussed in 2.2. Together with the LP points largely determined by proximity to the SA and XA DRCs, the third point near Borgseter (2.2.3) constitutes a triangle with sides of nearly equal length of about 100 km.

### 2.4 Drilling and casing, requirements and domestic capacity

It was realized that drilling of the required number of holes (25 - 27) through overburden and into bedrock would be one of the bottlenecks in the drive to get Phase 1 installations ready before winter conditions would stop further work in the field. This applied primarily to the Øyer area, but also concerned the XA site.

It was decided that the depth in bedrock should be  $15 \pm 1$  m. This was a compromise taking into account the available drilling capacity, the increase in cost with depth and seismological considerations. It was also stipulated that the cylindrical 4.75 inch diameter SP seismometer should be protected by and rest on the bottom of a sealed steel casing. This called for a drilled hole of minimum diameter about 160 mm.

Due to a maximum allowable tilt of  $5^\circ$  from the vertical of an SP seismometer in operation, a maximum allowable deviation of  $3^\circ$  from the vertical was specified for the drilled hole at the depth corresponding to the seismometer position; i.e., the lowest 4 meters for the subarray holes and at all levels for deep holes in the noise study array. The safety margin of  $2^\circ$  would allow for inevitable small tilts; hole/casing and casing/seismometer.

A first brief survey among the major well-drilling firms in the Oslo area revealed that their capacity in terms of drilled meters per day in rock was limited and that only one of them had a little experience in drilling diameters of the order of 160 mm. None of them had earlier experience in full-length casing of boreholes.

However, after further interviews and inspection of an operating drill rig and workshops by an LL consultant (excerpts from consultant's report, Appendix 1.2), the largest of the drilling companies was accepted as a potential contractor for drilling and casing.

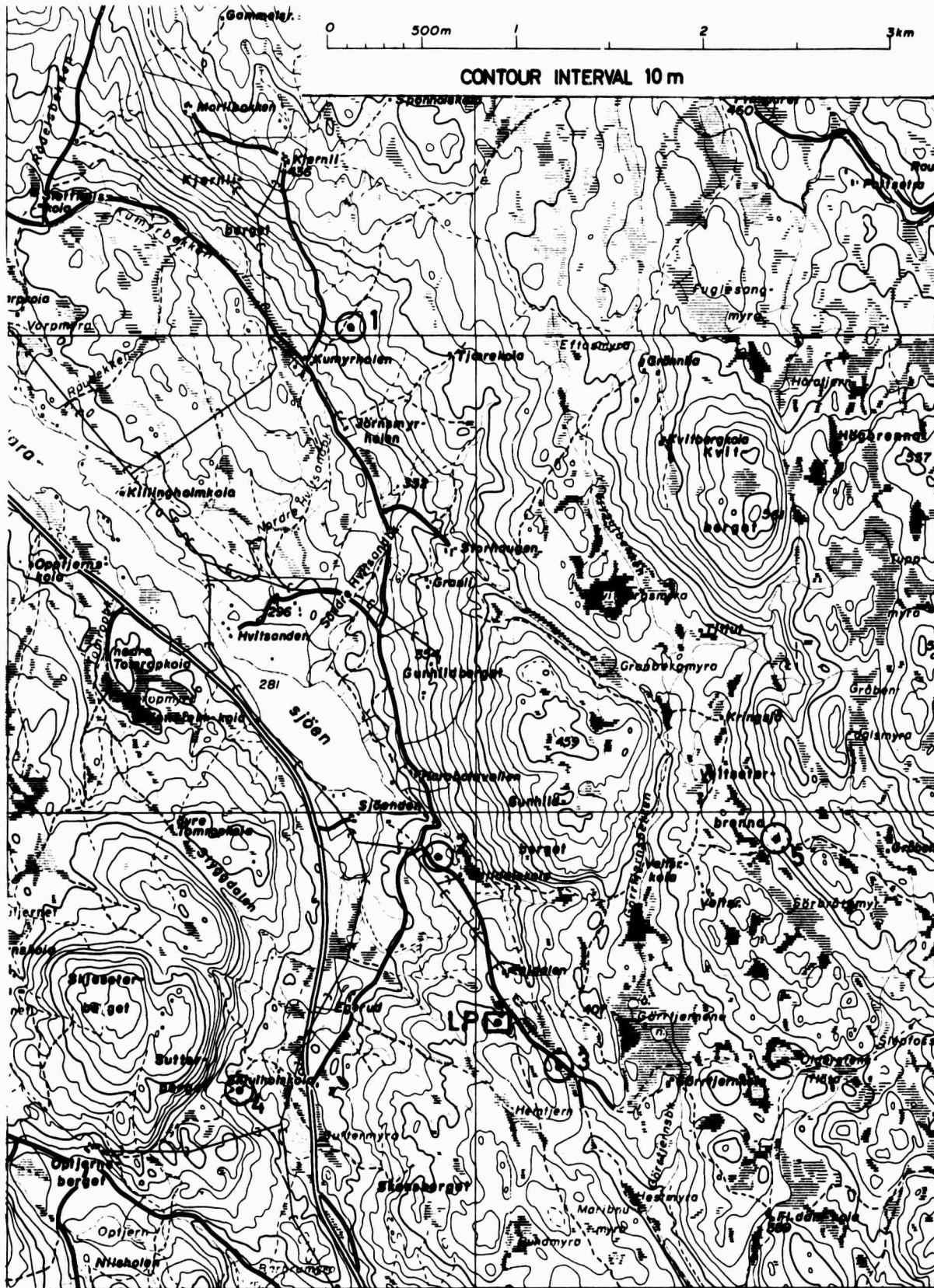

Figure 2.7 Noise study array configuration

## 2.5 Well head vault

As specified by Lincoln Laboratory, an oil drum container for seismometer/signal cable interfacing circuitry is placed on top of the borehole casing (Figure 2.8). This Well Head Vault (WHV) together with the casing tube and cable entrances forms a sealed unit to keep moisture away from the seismometer and the electronic equipment.

This equipment is placed in two boxes, the Amplifier Box (AB) and the Junction Box (JB). AB contains a parametric preamplifier and circuits for calibration purposes. JB has lightning protection gear and interconnecting circuitry for AB to cable connections and for by-passing power and signals to other seismometer WHVs.

It appeared from the LL/NDRE discussions that early delivery of the equipment would best be accomplished by a US/Norway job sharing, in which LL supplied the preamplifier and special long lead time components, while the remainder of the job was left to a Norwegian subcontractor. In addition to production of AB and JB, the job also comprised manufacture of the WHV, a retaining ring and a coolie hat shaped lid.

Since time did not allow selection of a subcontractor by competitive bidding, NDRE called on the company Noratom-Norcontrol A/S (N-N) to estimate the volume of work involved, produce a schedule securing delivery of the equipment in time, and offer a bid for the job.

## 2.6 Seismic signals transmission within sites

In discussions between representatives of ARPA, ESD and NDRE, it was decided that the signal connections between seismometers and the DRCs should be provided by ditched cables. There were several reasons for imposing this stipulation. The CTV - DRC distances would be short at all sites, of the order of 100 m. Pole line connections WHVs - DRC would not be acceptable in the open and treeless recreation area at Øyer. Such lines are also vulnerable to damage by weather (lightning, glaciation).

Laying of armoured cables on soil surface was also discussed as an alternative, but similar objections could be raised. Buried cables are in general better protected and would undoubtedly increase the reliability of the system as a whole.

The signal connections at the XA were excepted from the rule. These cables would be laid on soil surface in order to save time and also because of the interim character of the installation.

### 2.6.1 Trenching

Contact was established with Fjernkabelkontoret (The Long Distance Cable Office, LDCO) of the NTA, which is probably the Norwegian institution most experienced in

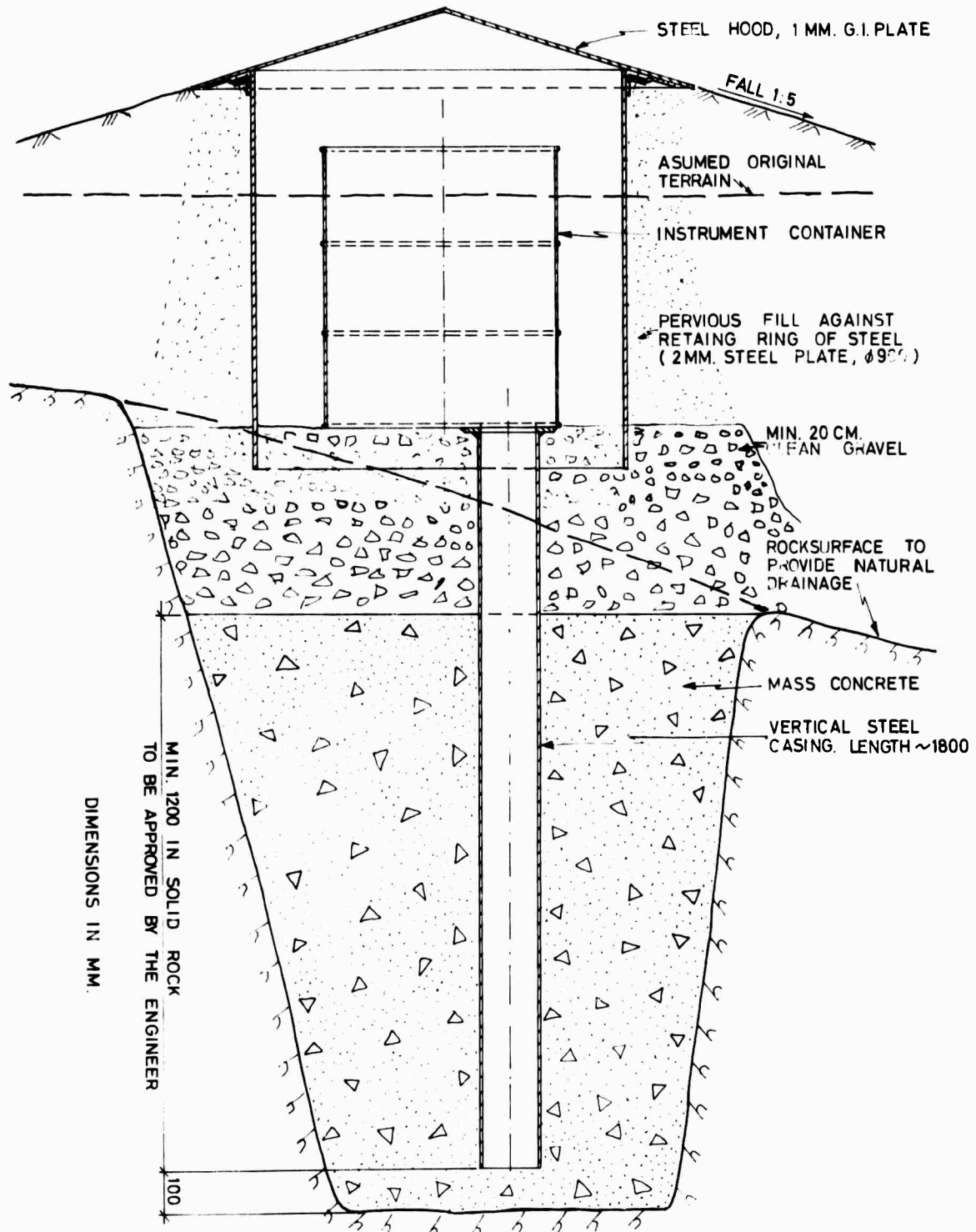

Figure 2.8 SP seismometer hole with casing and WHV (shallow hole, Falldalen)

trenching of communication cables through country like the Øyer plateau. LDCO strongly recommended a trench depth of 50 - 60 cm to avoid upheaval of the cable due to thawing of frozen earth in spring. LDCO would hesitate to accept the main trenching contract if this condition were not consented to.

### 2.6.2 Seismic signal cables

The basis for choice of cable was US Rural Electrification Association (REA) cable specification sheets used for the LASA installation, and also an LL/NDRE decision on number of pairs. Theoretically the basic requirement for a single WHV - DRC connection was:

- 1 pair for the seismometer signal
- 1 " " " calibration signal
- 1 " " " seis bypass relay
- 1 " " telephone connection
- 1 " " the DC power supply

This minimum number of pairs was insufficient for the following practical reasons. The hexagonal pattern of WHVs (Figure 2.5) called for a single cable connection DRC - inner hexagonal points, i.e. each of these cables should take care of three WHVs, and even four WHVs in the F leg. Three WHVs needs would treble the number of seismometer signal pairs, bringing the total number of pairs up to 7; 8 pairs for the innermost part of the F leg. Furthermore, the DC power drain at WHVs would also cause unacceptable voltage drops in one pair (19 AWG conductors) over the distances involved. This might be solved by putting in a special heavy conductor pair for power. However, using several pairs in parallel was considered a more flexible solution. It would then be necessary to use three or four pairs for power distribution. Adding a spare pair, the total number of pairs DRC - 1F4 would amount to 12.

It was decided to use a 12 pair cable throughout the array, even if this would introduce some redundant pairs in the connections inner-to-outer hexagon. When this decision was made there also existed a possibility that further WHVs might be put in outside hexagon 2.

An order for 100 km of 12-pair cable was placed at Standard Telefon- og Kabel-fabrik (Standard Telephone and Cable Company, STK, Oslo, Norway), after comparison with price bids and delivery times quoted by other sources.

The specifications for the cable, STK type A 12-0.91 EWBP - 52P, are given in Appendix 2.

This cable would also be used for the LPV - DRC connection at all sites. A six pair cable for the XA was brought in from the US by LL.

## 2.7 LP vault

As mentioned briefly in 1.2, it was nearly an absolute requirement that each LP seismometer installation should be contained in an underground vault. The economical penalty imposed by going underground is balanced by the increase in the signal-to-noise ratio.

Maximum seismic coupling to the ground is obtained by pouring the concrete for the vault floor directly onto the exposed bed-rock. Transmission of noise from the soil surface (wind, precipitation, animal- and man-made noise) down to the seismometers is attenuated by having the uppermost parts of the vault (roof, man-hole entrance) a few feet below soil surface. Entrance to the vault should be through a well-like structure placed above and coaxially to the manhole. To enhance the decoupling of surface noise this structure should not rest directly on top of the vault, but be separated from this by a layer of soil materials.

Other important parameters introducing seismic noise are rapid time variations in temperature and atmospheric pressure in the seismometers and their environment. The temperature stabilization obtained by going underground is considerable, and fluctuations in the atmospheric pressure are dampened by placing the seismometers inside airtight tanks and by sealing the vault itself.

The shelter-type vault design used in the LASA was ruled out for NORSAR, even though it proved to be very economical and time-saving in Montana. The major feature of this design was the use of a prefabricated, easily mountable and demountable inner mould, while the wall of the hole dug in the soil constituted the outer mould for the cement. To cut a regular hole with reasonable tolerances was possible in Montana, whereas Norwegian soil types do not lend themselves for this method of construction.

The task of designing a Long Period Vault (LPV) suitable for Norwegian conditions obviously called for local experience and was entrusted to Norconsult A/S (NC) in collaboration with US consultants responsible for specifications, and subject to approval by the Technical Project Officer (TPO).

The final design (Figure 2.9) is an almost cubical, reinforced concrete vault sized to allow sufficient space for personnel to install, adjust and maintain the technical equipment. The cylindrical steel tanks for the seismometers would have open bottom ends and be sealed by being moulded into the concrete floor. Details of the entrance include a wall ladder, a steel manhole with an airtight cover and a superstructure composed of a lid-covered shaft through the overburden.

The manhole cover and the steel tank lids are fitted with couplings for testing of airtightness.



## 2.8 Housing of the signal acquisition systems

As briefly mentioned in 1.2, it was stipulated that operation of the Phase 1 installations should be based on data-recording at the DRCs. The analog signals from the seismometers were to be sampled, analog/digital (a/d) converted and recorded on magnetic tape together with digital codes for recorders/site identification and time. A field crew would be required to give regular attendance to the recording equipment, the extent of this service being dependent upon data input rates (number of tape shifts per unit time) and the quantity and complexity of the array equipment in general.

The plans for operation of the Phase 2 installations (large array) assumed on-line data handling, i.e. the digital codes would be transmitted from the subarrays and LPV stations to a Data Processing Center (DPC) somewhere in south-eastern Norway, where real time event detection and subsequent event analysis would take place. The data terminals at the sites would essentially be unattended; only very infrequent visits for maintenance and fault corrections were anticipated.

Data-recording at the Phase 1 sites would cease when the DPC went into operation. As a consequence of this, only temporary housing would be needed to accommodate the recording equipment and give working space for the field personnel. At the Øyer subarray this temporary housing would also have to include living quarters for a permanent staff of two technicians from the field crew.

### 2.8.1 Temporary housing of the DRCs

Time shortage ruled out conventional methods for construction of the housing facilities. It was agreed that use of prefabricated building units was the way to solve the housing problem.

Among several producers of prefabricated units in Norway, it was generally accepted that Moelven Brug A/S, by far the largest and most experienced of them, was best equipped to meet the needs. Negotiations brought out that the company, by being somewhat out of its way, would be able to deliver units meeting the quantity and quality requirements within the narrow time limits stipulated.

#### Øyer DRC

Space and quality requirements for the Øyer DRC comprised the following:

- a) An instrument room dimensioned to accommodate and service the SP and LP recorders and other data handling equipment.
- b) A smaller room for office use with telephone and telex facilities.
- c) Space for storage of magnetic tapes, spare parts and tools in general.
- d) Living quarters for a stationary crew of two men, and emergency accommodation for occasional visitors.
- e) The house should be thermally insulated and have electric heaters dimensioned for severe winter conditions.

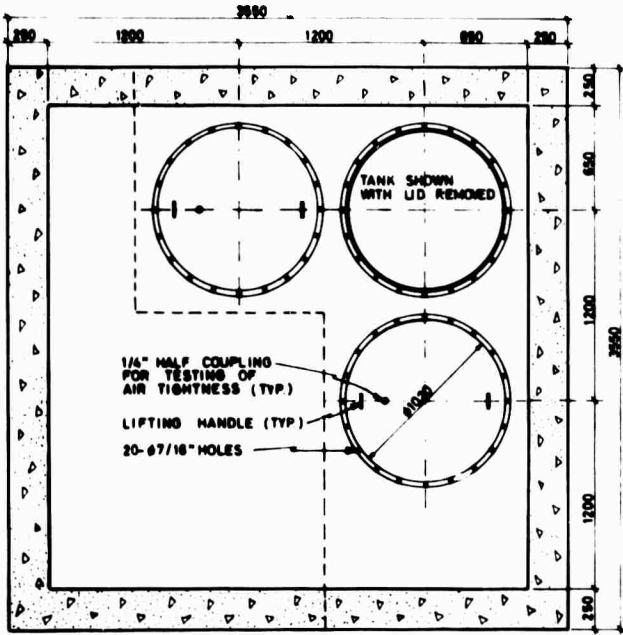

SECTION C-C

**NOTES**

- 1 ALL DIMENSIONS IN MM UNLESS WHERE OTHERWISE NOTED
- 2 CONCRETE, 8300 (MIN 28 DAYS TEST - CUBE STRENGTH 300 KP/CM<sup>2</sup>)
- 3 REINFORCEMENT, DEFORMED BARS, HIGH TENSILE STEEL, RS 40  
 FLOOR: 1 LAYER BOTH WAYS  $\phi 10$  c200  
 WALLS: 2 LAYERS VERT. & HOR  $\phi 12$  c300  
 ROOF: 1 LAYER BOTH WAYS  $\phi 12$  c200
- 4 STRUCTURAL STEEL ST 37.2
- 5 TIMBER COVER TO ENTRANCE SHAFT INSULATED WITH 6" FOAM PLAST

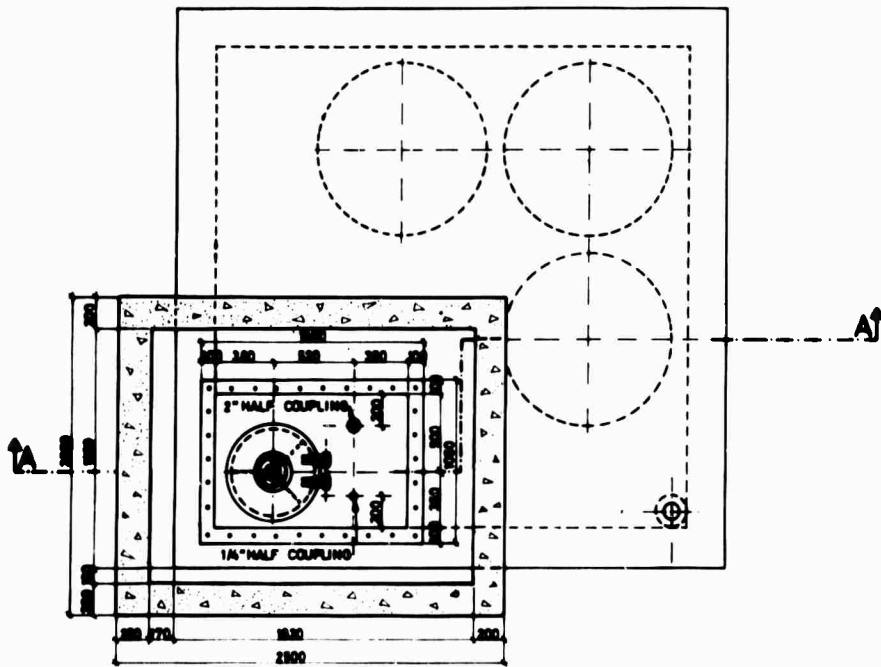

SECTION B-B

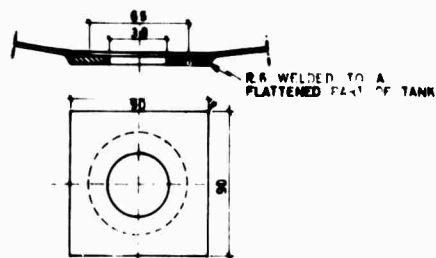
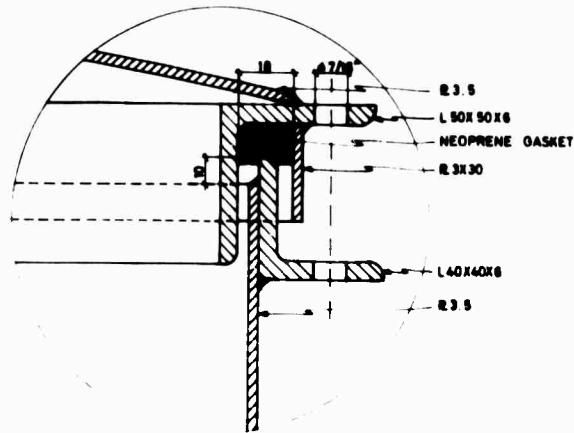
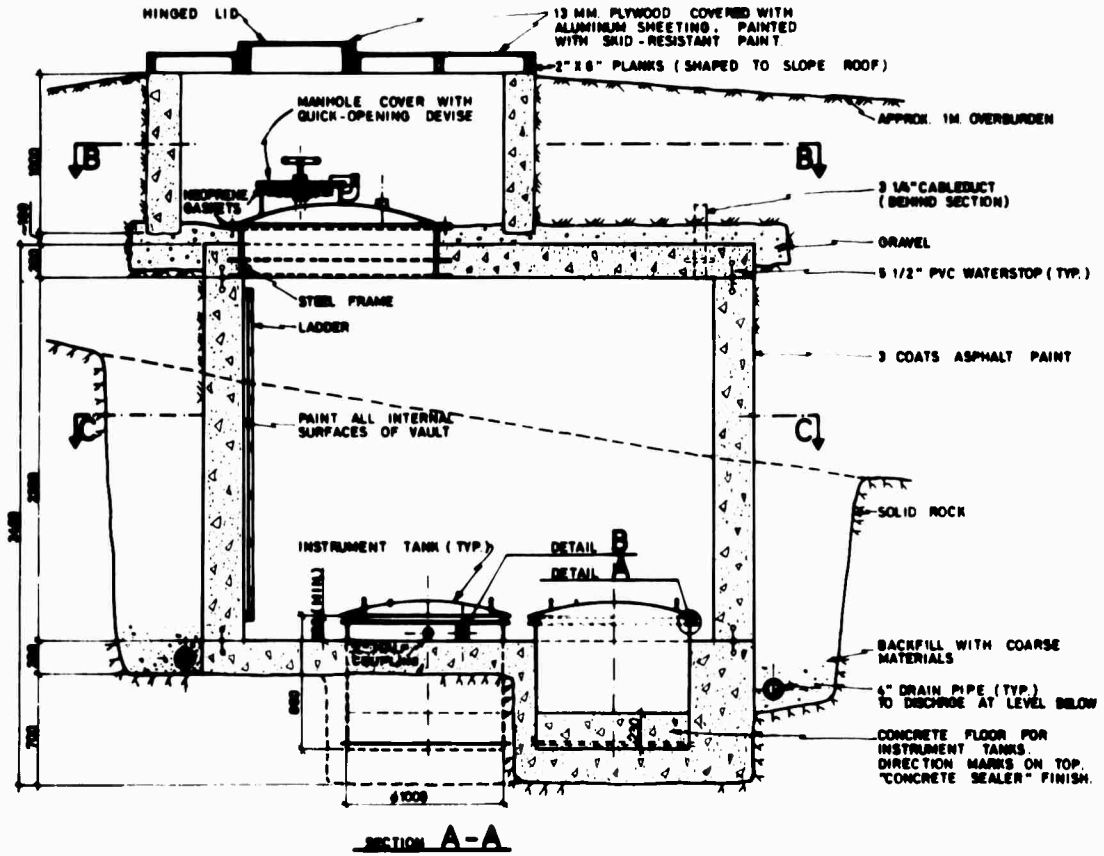

**NOTES**

- 1 ALL DIMENSIONS IN MM UNLESS WHERE OTHERWISE NOTED
- 2 CONCRETE 0.300 (MIN 28 DAYS TEST-CUBE STRENGTH 300 RP/CM<sup>2</sup>)
- 3 REINFORCEMENT: DEFORMED BARS, HIGH TENSILE STEEL RS 60  
 FLOOR 1 LAYER BOTH WAYS 610 c 200  
 WALLS 2 LAYERS VERT. & HOR 612 c 300  
 ROOF 1 LAYER BOTH WAYS 612 c 200
- 4 STRUCTURAL STEEL ST 37.2
- 5 TIMBER COVER TO ENTRANCE: SHAFT INSULATED WITH 6" FOAM PLAST

Figure 2.9 Long period vault

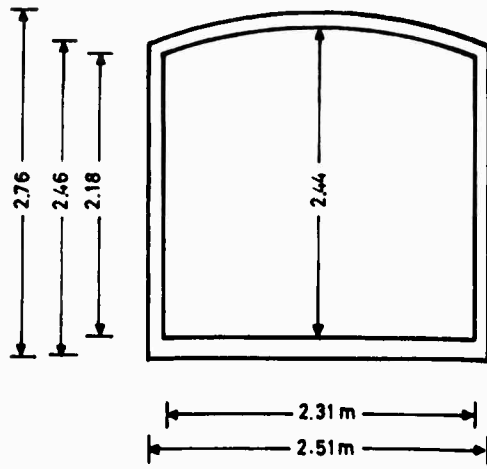

Section through Moelven unit

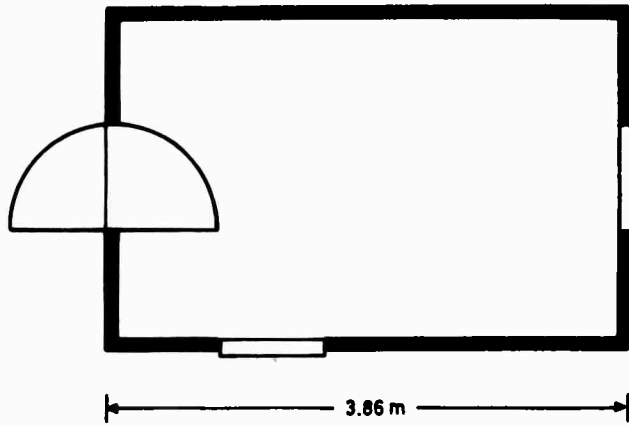

Type 39A

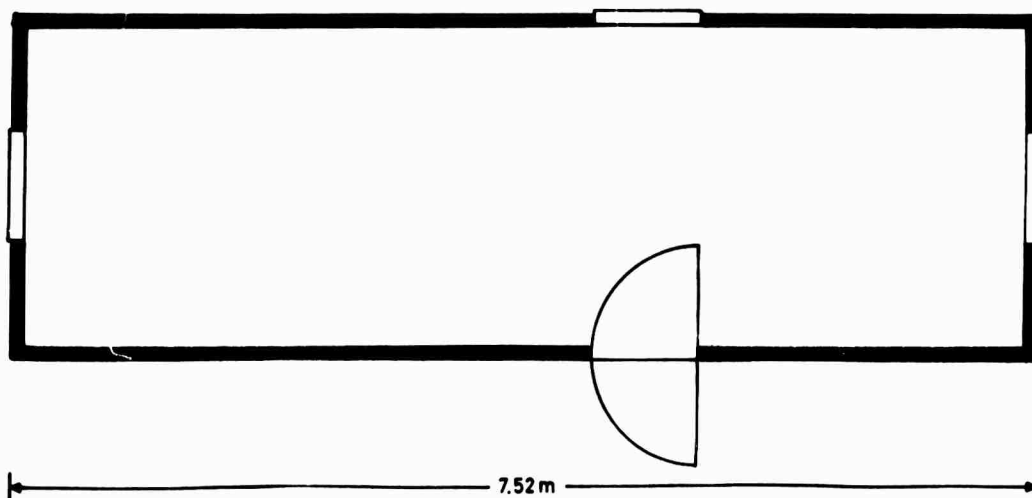

Type 75A

Figure 2.10 Prefabricated units from Moelven Brug A/S

Among the company's standard line of products, based on a few basic building units and a choice of unit combinations (Figure 2.10), a four- or five-unit combination seemed preferable. However, delivery time restrictions enforced choice of a three-section house (Figure 2.11) representing a minimum but still sufficient coverage of the needs.

The weight of the recording equipment exceeded the standard carrying capacity of the floor and the company agreed to put in extra beams to strengthen it. The company were also to produce a foundation plan and take care of transport from factory to site when this was called for.

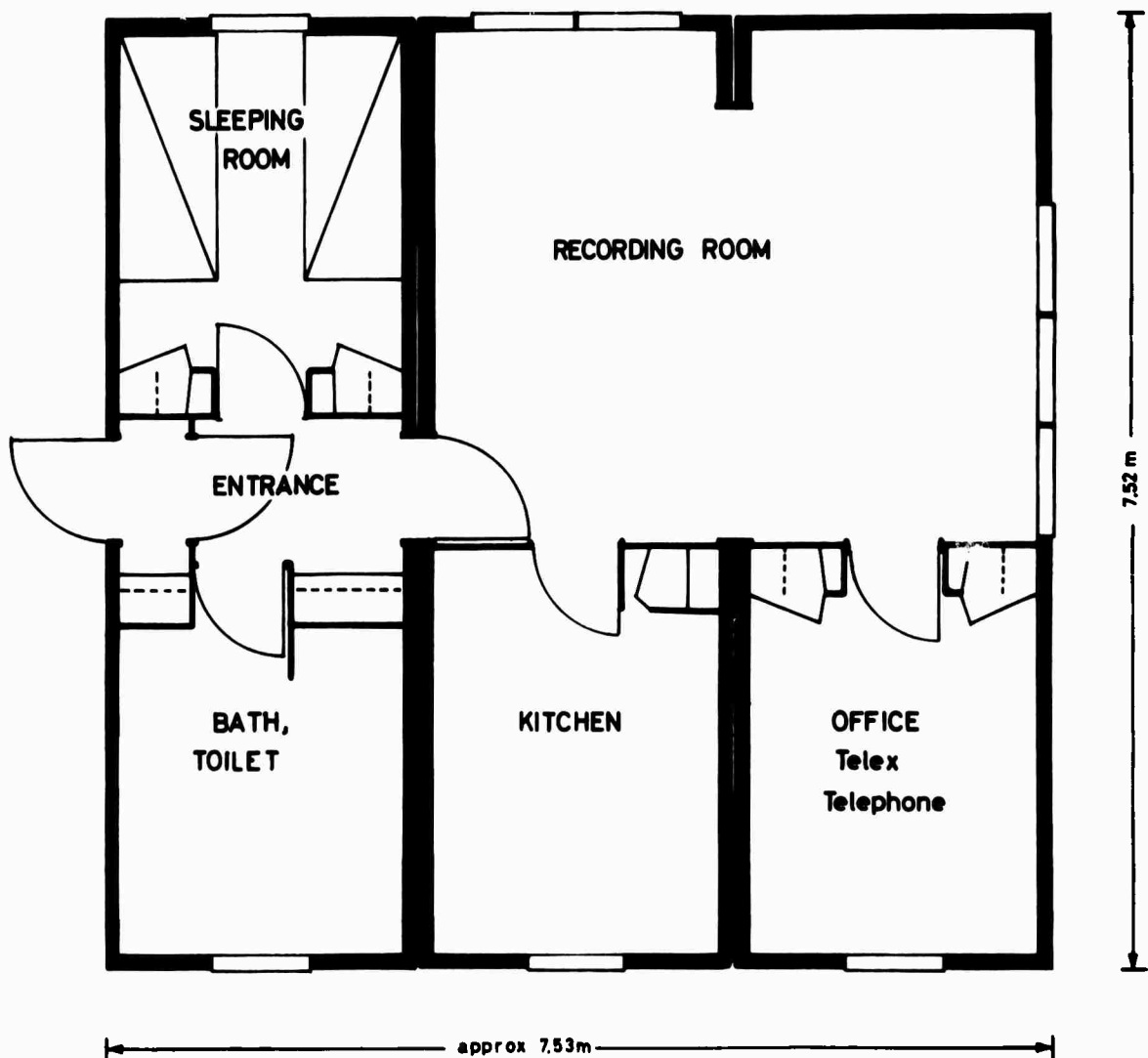
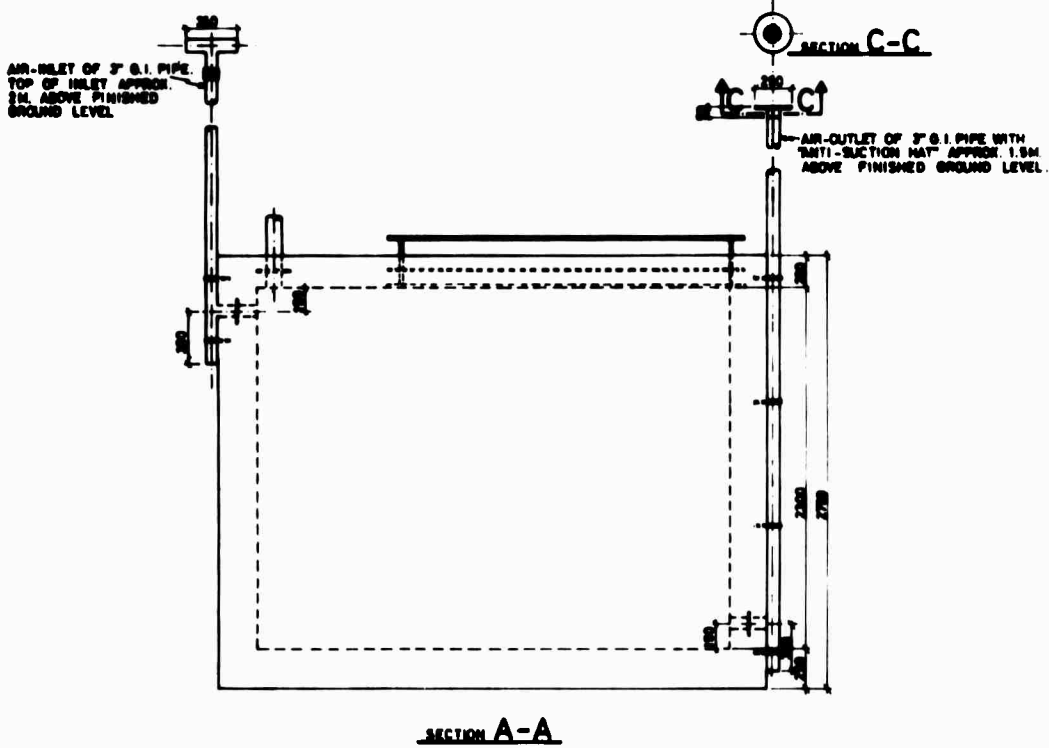
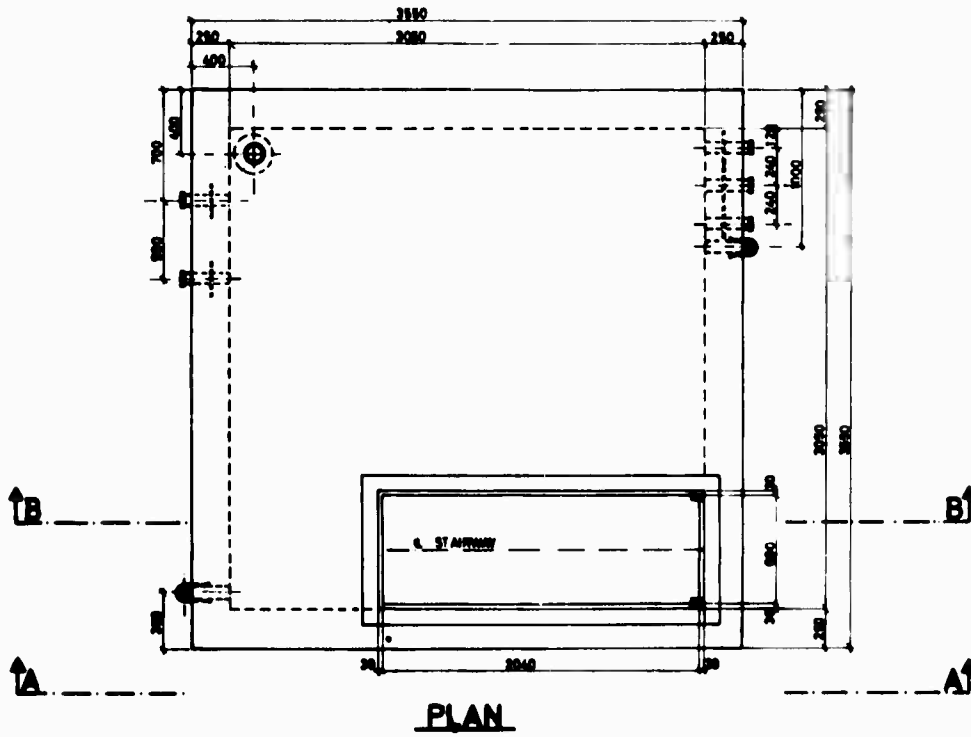

Figure 2.11 Three-section house for Øyer DRC

#### Falldalen and Borgseter DRCs

Operation and maintenance of the Falldalen and Borgseter DRCs would obviously not require personnel to stay at the sites round-the-clock. It was roughly estimated that a visit once or twice a day at Falldalen and about once a fortnight at Borgseter would suffice, and both sites would be accessible throughout the year. The



**NOTES**

1. ALL DIMENSIONS IN MM UNLESS OTHERWISE NOTED
2. CONCRETE 8300 (MIN 28 DAYS TEST-CUBE STRENGTH 30% YP/CM<sup>2</sup>).
3. REINFORCEMENT, DEFORMED BARS, HIGH TENSILE STEEL R5 40.
 

FLOOR	1 LAYER BOTH WAYS	ø10 c 200
WALLS	2 LAYERS VERT & HOR	ø12 c 300
ROOF	1 LAYER BOTH WAYS	ø12 c 200
4. STRUCTURAL STEEL ST 37.2

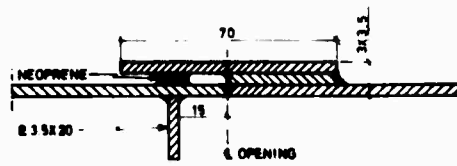
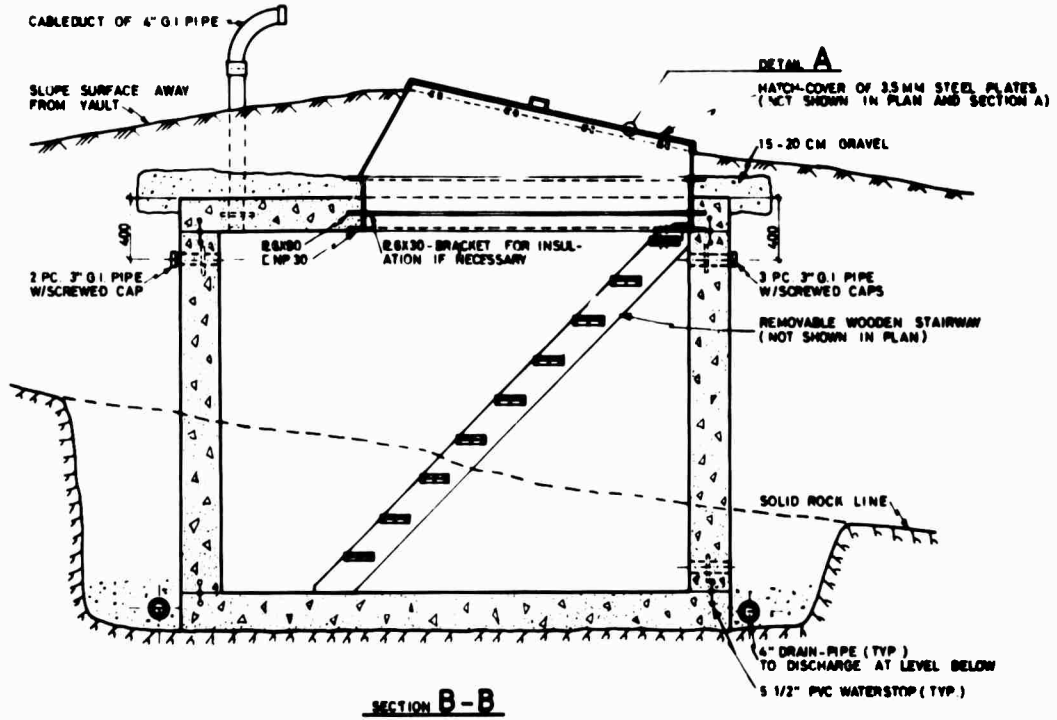

DETAIL A  
SEALING BETWEEN DOUBLE LIDS  
SCALE 1:1

**NOTES**

1. ALL DIMENSIONS IN MM UNLESS OTHERWISE NOTED.
2. CONCRETE: 300 (MIN 28 DAYS TEST-CUBE STRENGTH 300 MP/CM<sup>2</sup>).
3. REINFORCEMENT: DEFORMED BARS, HIGH TENSILE STEEL RS 40.  
 FLOOR: 1 LAYER BOTH WAYS  $\phi 10$  c 200  
 WALLS: 2 LAYERS VERT. & HOR.  $\phi 12$  c 300  
 ROOF: 1 LAYER BOTH WAYS  $\phi 12$  c 200
4. STRUCTURAL STEEL ST 37.2

Figure 2.12 Central terminal vault

two DRCs could therefore easily be attended to by a staff of one or two men stationed at a central place, not too far from Falldalen, e g at Hamar (Figure 1.1). Thus, the housing requirements at the two sites confined themselves to technical equipment accommodation and some extra space necessary for servicing, book-keeping, storage etc.

It was established that the largest of the Moelven basic units (Type 75A, Figure 2.10) would cover the Falldalen DRC needs, while the smallest unit (Type 39A, Figure 2.10) would do for the Borgseter DRC.

### 2.8.2 Central terminal vault

The plans for Phase 2 anticipated that the Øyer subarray should be incorporated in the large array pattern. Even if not needed for the Phase 1 operation, there were good reasons for installing the permanent terminal housing (2.8) for the data converting and transmitting equipment at this stage. It would be cheaper to do this when resources for the construction of the LPV and temporary house foundation were already present at the site. This also applied to trenching and cable-laying, which could easily be modified to take care of a future arrangement. Apart from pure economical reasons, it was also considered worth while to gather information on how a prototype terminal design would stand the winter season.

It was readily agreed that the terminal had to be placed underground. In the open, treeless recreation area at Øyer, a permanent structure above ground would catch the eye and probably not be easily tolerated. But also technical and security reasons pointed out this alternative. Compared to a hut above the ground, an underground vault would tend to give the electronic equipment much stabler environment in general and more constant temperature in particular. This and the better protection offered by the vault would both contribute to the system reliability.

The designing of the Central Terminal Vault (CTV) was done by NC in close cooperation with the LL/Philco consultants. The final design is shown in Figure 2.12. The vault is a watertight structure of reinforced concrete with main dimensions equal to those of the LPV. No seismological considerations had to be taken into account in this case; consequently the vault floor would not necessarily (even if drawn in the figure) have to rest on bedrock and no special entrance superstructure was needed for attenuation of surface noise. The entrance to the vault is by a steel hatch and a wooden stairway. Passive ventilation is provided by two vertical steel pipes, both fitted with a bottom well to catch condensed moisture.

As an arrangement preparatory to Phase 2 it was decided to run the signal cables from the WHVs and the LPV through the CTV on their route to the DRC. One would leave a loop of each cable inside the vault in order to have spare lengths ready when needed for the final termination within the CTV. It was also assumed that the cables between the CTV and the DRC should be laid on the soil surface. For this purpose the vault was fitted with an extra vertical cableduct through the vault roof.



## 2.9 Power supplies

In addition to electric power for the data recording equipment, power would be needed for heating and lighting at the DRCs, and at Øyer also for the household appliances.

### 2.9.1 Power supply for the Øyer DRC

It was estimated that the power consumption of the data handling equipment would be of the order of 3 - 5 kW, and that heating and household appliances might take another 8 - 10 kW.

Moksa Kraftanlegg (Moksa Power Company, MPC, Tretten) is the sole authorized supplier of commercial power in the area. In discussions with MPC it was brought out that a 220 V supply would not be feasible, as the minimum distance from the DRC to the 220 V grid was about 12 km. To bring in 10 - 15 kW at this distance with a reasonable voltage drop would give prohibitive copper costs.

A 10 kV branch line was available at the southern rim of the subarray area (Figure 2.6), but MPC pointed out that this line was unreliable and had breakdowns rather frequently, especially in the winter. MPC strongly advised against using it as a power source. In fact, MPC would not recommend tapping any of the existing branches of the 10 kV grid if high reliability and voltage stability were important. It would pay to put in an exclusive 10 kV line directly to the power station, even if the total distance would amount to about 15 km.

The high cost estimated for this connection made it necessary to consider use of diesel generators at the site as an alternative. One would have to put in two generator sets at 15 kW each, no 2 being a standby emergency unit to take over the load automatically in case of failure of no 1. Including extra housing for the generator sets and for fuel storage, the cost of power from this set-up was lower than for commercial power, but the saving was less than anticipated. From a seismological point of view there were doubts as to the wisdom of introducing a seismic noise source of this size in the vicinity of the LPV and the central WHV. A long and not well defined delivery time for the sets was another objection of importance.

In sum, the objections made this alternative less attractive, and it was decided to accept the original proposal in spite of the higher cost.

In accordance with the adopted policy (2.6), the 10 kV connection would go as trenched cable from the DRC to the timber-line at the western rim of the plateau (Vetlsetra) and as pole-line down the wooded hillside to Moksa Power Station. The power cable route would follow the same general direction from the DRC as the telecommunication cable and one of the seismic signals cables, hence the possibility of co-locating several cables in a common trench was discussed.

Co-location of power and telecommunication cables was found to be acceptable; however, the analog signals in the seismic cable would be more vulnerable to crosstalk noise. Therefore, a separate and exclusive trench for the seismic cable was stipulated (Figure 2.13).

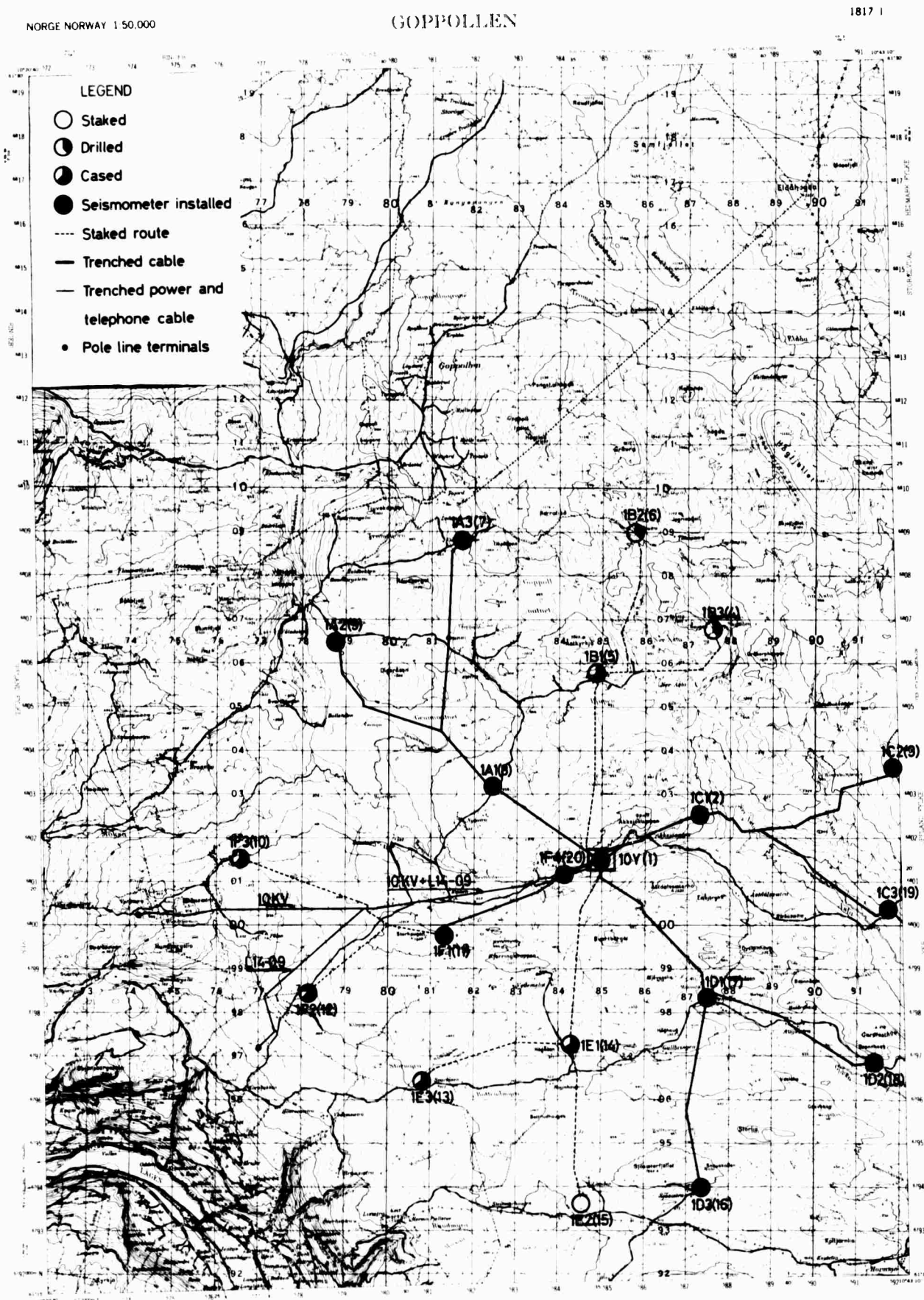

Figure 2.13 Subarray status by end of 1967 installation season

MPC was charged with the planning of the complete power installation except the trench Svartsetra - DRC. However, MPC's responsibility included purchase of power cable for that trench.

#### 2.9.2 Power supplies for Falldalen and Borgseter DRCs

At both places the data recording hut would be situated a few hundred meters from 220 V commercial power lines, and no excessive voltage drop would be encountered at any of the places. In answer to inquiries, the local power companies (Stange E-verk for Falldalen and Sagnfossen Kraftanlegg for Borgseter) stated that they were prepared to execute orders for power connections well within the time limits specified.

#### 2.10 Telecommunications

The telecommunication facilities in Norway are almost 100 per cent owned and operated by the State through Telegrafverket (The Norwegian Telegraph Administration, NTA) and its central managing authority, Telegrafstyret (The Norwegian Telegraph Administration Board). The country is divided into a number of districts, each headed by a District Office (DO). The districts are divided into a number of control areas, tied to local Telegraph Stations (TS), each headed by a Telegraph Station Manager (TSM). In the course of establishing telecommunication facilities for the NORSAR sites, negotiations were carried on with the NTA Board, the DO and the TSMs involved.

It was necessary to have telephones installed at all sites at the earliest possible date to coordinate vault construction, transport and installation of technical equipment and to perform the final check out. No problems arose concerning this at the Falldalen and Borgseter sites, as the distances from the DRCs to the nearest available connection points of the NTA network were moderate, in the order of one to two kilometers. Inquiries at the telegraph stations concerned, Hamar TS for Falldalen and Elverum TS for Borgseter, were answered positively: upon receipt of subscription orders both were ready to carry out the installation within reasonable time limits.

There was a finite possibility that the LP installations at the two sites would be incorporated in the Phase 2 system. The local branch lines of the NTA network would then have to be strengthened to manage the on-line data rate, about 600 baud from each LPV. It was agreed that a decision on this would have to wait for the final Phase 2 plans.

##### 2.10.1 Telecommunications for Øyer DRC

The efforts put into the telecommunication link at Øyer would far exceed those at the other sites. There were two main reasons for this: the need for a high capacity connection and the remoteness of the site.

Installation, check out and operation of the Phase 1 system only called for a telex facility in addition to the telephone, and would not by itself require a high capacity

link. However, a link with a much wider bandwidth would be needed to carry the moderately filtered subarray/LP information on-line to the DPC of Phase 2. Considering the high probability for later incorporation of the Øyer SA in the large array system, it became a matter of course to put in the necessary transmission capacity at this stage.

The total information output rate from the CTV was calculated to be nearly 2400 baud. This data rate would occupy four pairs of a standard telephone cable; the telephone and teleprinter would take another couple of pairs. Adding capacity for calibration and control signals from the DPC and some spare capacity for future needs, it seemed reasonable to specify a standard 14 pair telephone cable for the link.

The responsibility for planning the connection was shared between Fjernkabelkontoret (Long Distance Cables Office, LDCO) of the NTA Board and Lillehammer TS of the NTA. LDCO was charged with routing, trenching (major part common power/telecommunication trench, see 2.9.1) and cable-laying from the DRC to the trench termination point (Figure 2.13) at the western outskirts of the mountain plateau, while Lillehammer TS accepted responsibility for the remainder of the connection.

## 2.11 Instrumentation

Planning of the instrumentation was entirely done by LL, which was also responsible for the provision of all hardware except parts of the WHV equipment (2.5).

### 2.11.1 Øyer SP subarray

#### SP seismometers

All sensors to be used in the subarray were identical Hall-Sears HS-10-1 (ARPA) vertical seismometers (specifications in Appendix 3.1) transferred from LASA, Montana. This seismometer is a spring-mass, velocity type instrument with a natural frequency of 1 Hz to cover the 0.2 to 5.0 Hz band. In addition to the signal coil it is fitted with an extra driver coil to enable remote calibration from the DRC (or DPC).

The cylindrical seismometer has outer dimensions 121 mm (4.75 in.), height 286 mm (11.25 in.) and is fitted peripherally with an axially oriented steel rod so that the lower end of the seismometer in operation will rest 152 cm (5 ft) above the bottom of the hole casing. The instrument is sealed.

#### WHV circuitry

The amplifier box (2.5) of the WHV circuitry contains damping and equalizing network, a low noise parametric amplifier (Texas Instrument RA-5, specifications in Appendix 3.3) and a signal coil by-pass relay enabling independent calibration of the amplifier proper.

The junction box (2.5) provides flexible interconnecting boards (tapered pin blocks) for AB-to-cable connections and for bypassing power and signals to and from other WHVs in the same leg (Figure 2.5). Lightning protection gas tubes are inserted at all inputs to the AB. AB and JB circuitry diagrams are found in Appendix 3.4.

#### SP recording equipment

Figure 2.14 is a block diagram of the SP recording equipment at the DRC, Øyer. The system itself and most of the blocks in it are designed and manufactured by Astrodata. Blocks of other origin are mentioned in the text.

The incoming cables from the WHVs are terminated in a wall junction box within the DRC house. Lightning protection is provided for each of the incoming and outgoing lines. From the junction box, the data pass through individually adjustable dc-amplifiers which also serve as filters. The system is built for recording a maximum of 32 different data channels and contains 32 dc-amplifiers/filters.

Calibration signals may be fed simultaneously from the DRC to all seismometers from an external signal generator. Power is supplied to the field amplifiers from a power supply built into the system. A further power supply is used to operate the bypass relays placed in the WHVs.

A multiplexer samples all the dc-amplifier outputs 20 times a second and feeds the sampled signals through a dc-amplifier and a potentiometric amplifier into an analog-to-digital converter. This converts analog signals in the range of  $\pm 10$  V to 14-bit (13 bits + sign bit) words. From the ADC the words go through a data word register and a gate to buffer memory 1. In the data word register the words are extended to 18 bits by adding one parity bit and 3 extra sign bits. The words are split into three 6-bit characters before they are stored in the memory.

A time code generator gives information about the real time and date. The time data are contained in two 18-bit words which are fed every 2 seconds through the header data register and the gate to the buffer memory where they are stored in 6-bit characters. Two additional 18-bit words (header words), one representing the parity error status of the previous data record and the other containing information which can be selected from an external switch, are also stored in the header data register until the memory is addressed to accept them.

The buffer memory is a core memory manufactured by Ferroxcube Corporation of America. From this memory the data pass through a memory data register to either magnetic recorder 1 or 2 where they are recorded on digital magnetic tape. Since the tape recorder can record only seven bits at a time, each 18-bit word is recorded as three 7-bit characters (6 out of the 18 bits + 1 parity bit). The information is recorded on the tape as data records separated by a gap. Each data record contains 4 header words and 1280 data words, and requires 2 seconds recording time. The tape reels hold 2400 ft of magnetic tape which provides 2.6 hours of recording time. When one tape transport is recording data and the other is in the standby condition, the recording function is automatically switched to the standby transport when an end-of-tape tab is sensed by the recording transport. Consequently the system can re-

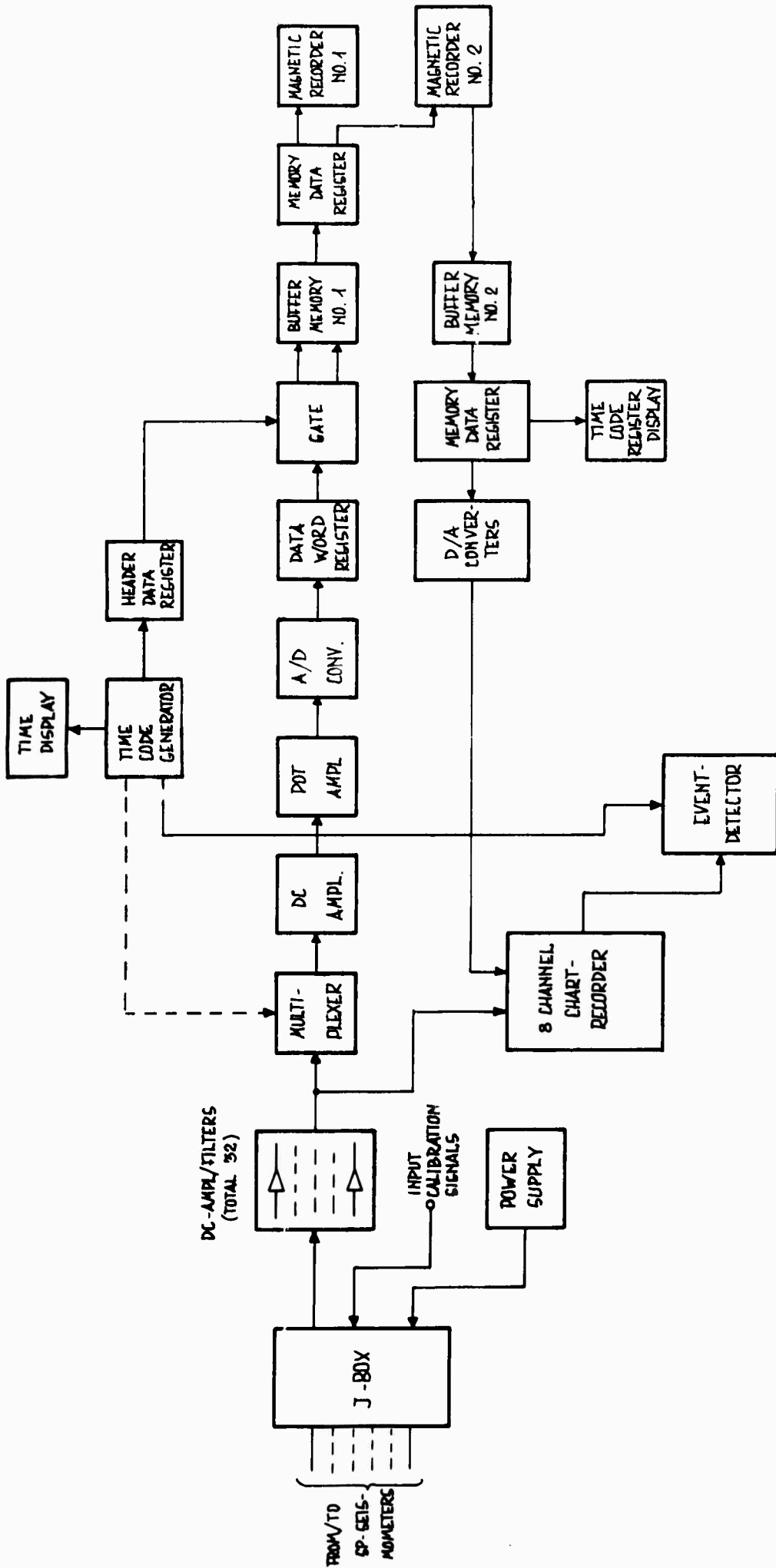

Figure 2.14 Block diagram of SP recording equipment (Astrodata) at Øver DRC

cord continuously for 5.2 hours without manual tape shift. The two tape stations are DATAMEC D2020 type.

The system also permits recording of data in analog form. This can be done on an 8-channel Sanborn chart recorder built into the system.

The data is then either fed directly from a chosen group of dc-amplifiers through a patching panel, or played back from tape transport 2 in the following way: Data from the chosen tape is loaded into buffer memory 2 where it is stored as 5-bit characters. One complete data record is loaded before the unloading starts. The memory input is synchronized with the tape speed, and the memory output is synchronized with the system clocks.

After unloading from this memory each character is stored in a memory data register where complete 18-bit words are formed. These words are then gated into a digital-to-analog converter (DAC) which has 32 input channels and 32 corresponding output channels with 32 different converters between them. The DAC only accepts 12-bit words, and therefore 12 bits are selected from each 18-bit word for application to the DAC. The converter converts each word into analog signals in the range  $\pm 10$  V. From the 32 outputs a group of 8 signals can be fed to the chart recorder. During playback time information is continually displayed on a time code register display.

The system finally contains a so-called event detector designed and built by Lincoln Laboratory. The detector derives its information from one of the data channels, and from the time code generator. It will detect events and record codes for time and strength of the events on teleprinter tape. Its principle of operation is to split the incoming data signal in four different frequency ranges. These four signals are then rectified and checked against an adjustable threshold. If all of them are higher than this threshold an event message is given after some seconds delay, and after checking that the four signals are increasing during this delay. The event detector threshold is adjusted to give approximately 4 event messages per day. (For further details on the recording equipment, refer to the appropriate manufacturers' manuals.)

The DART recording system, used at times for SP recording, will be described in the next section.

#### 2.11.2 LP array

##### LP seismometers and auxiliary equipment

Two instrument types are used in these three-axis installations, one Long Period Vertical Seismometer model 7505B for the vertical axis, and two Long Period Horizontal Seismometers model 8700D for the N-S, E-W axis (seismometer specifications in Appendix 3.2). Both types are velocity type instruments using a moving coil and a magnet to produce the signal. The natural frequency is adjustable and would be set at 0.05 Hz (20 seconds per cycle). When the cover of the rectangular container box is secured, the seismometer is sealed against water and against changes in the atmospheric pressure. Within a steel tank in the LPV the instrument is thus trebly protected against pressure changes.

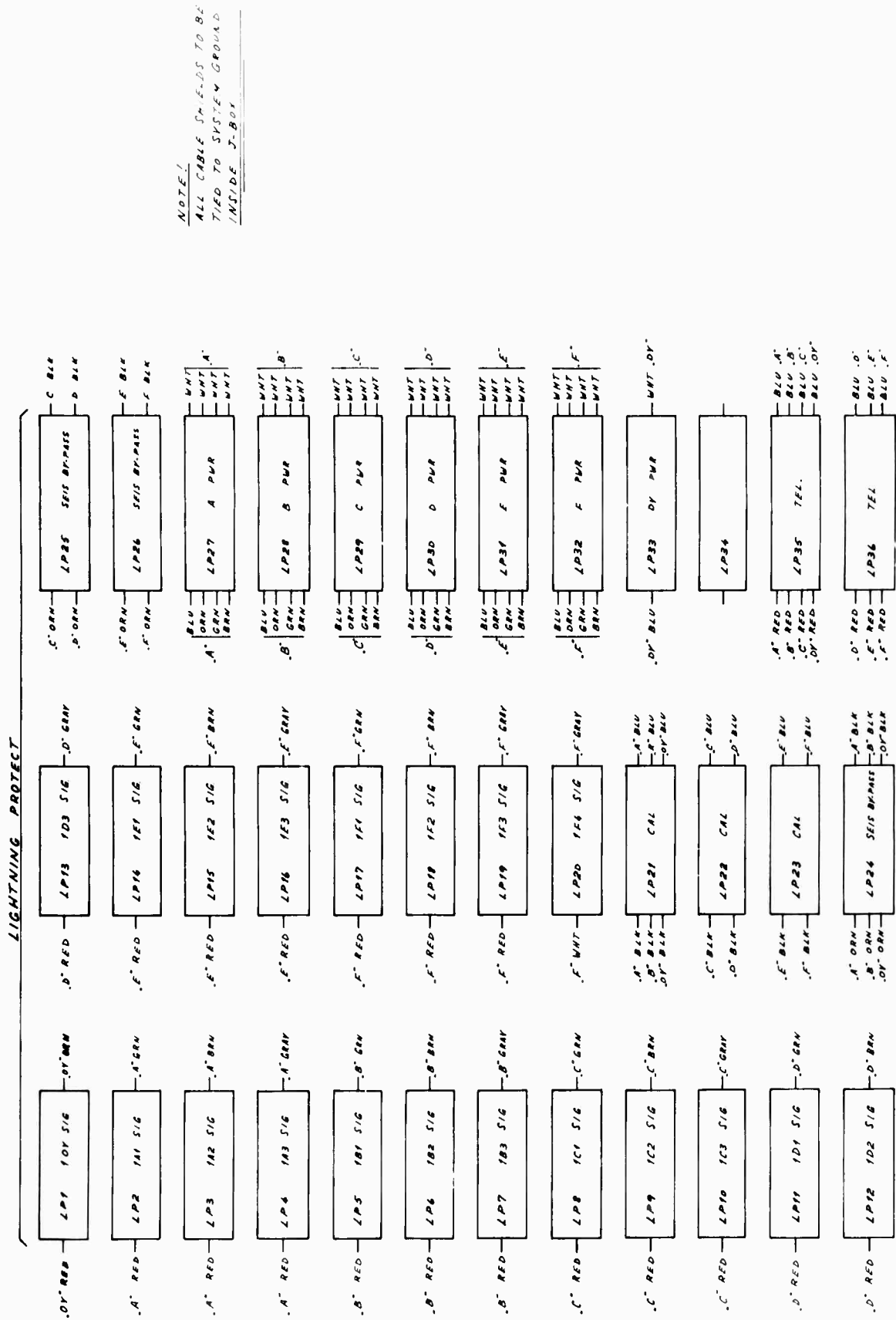

Figure 2.15 Termination of WHV cables in DRC wall junction box



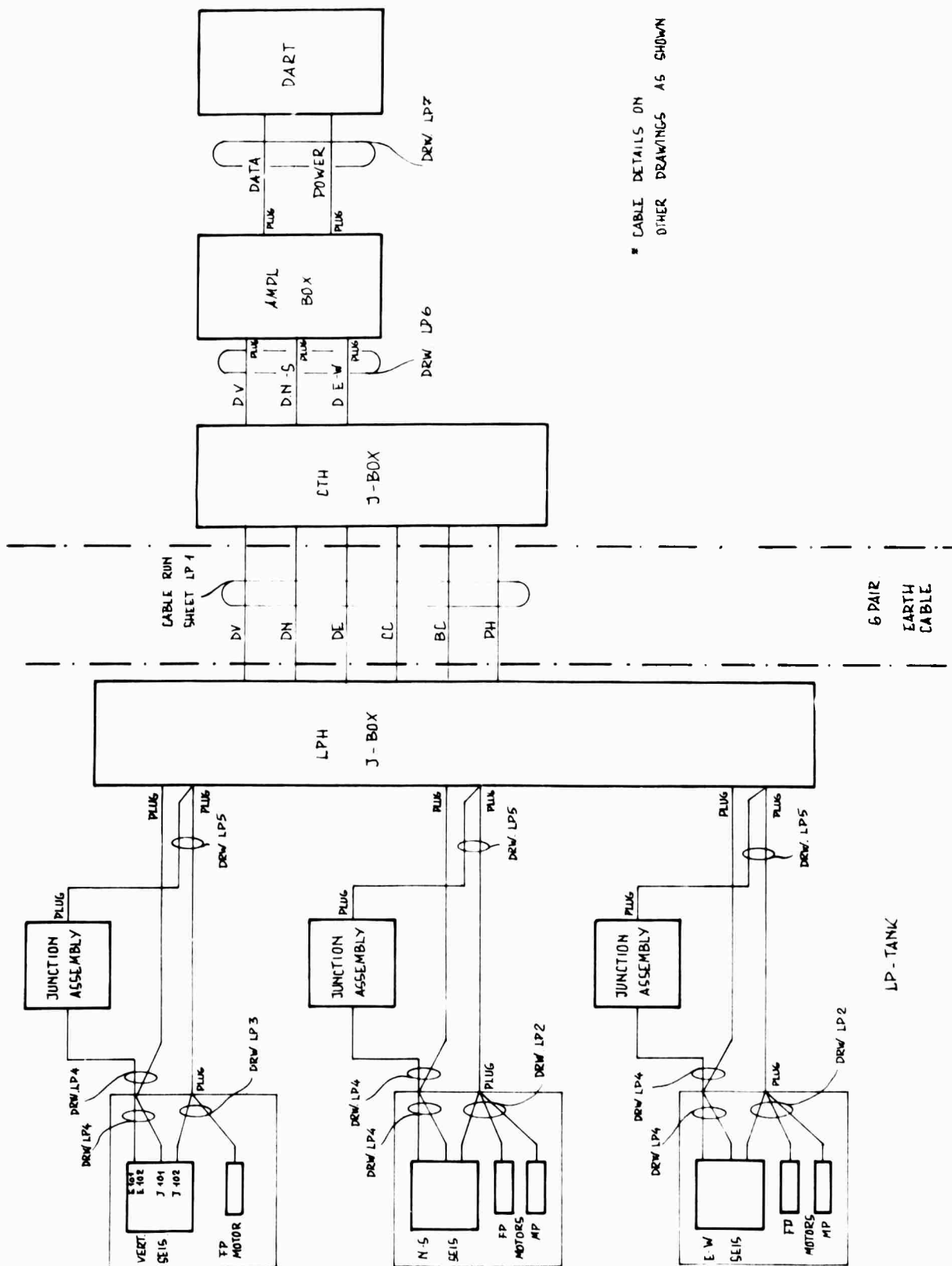

Figure 2.16 LP installation (equivalent at Øyer, Falldalen and Borgseter)

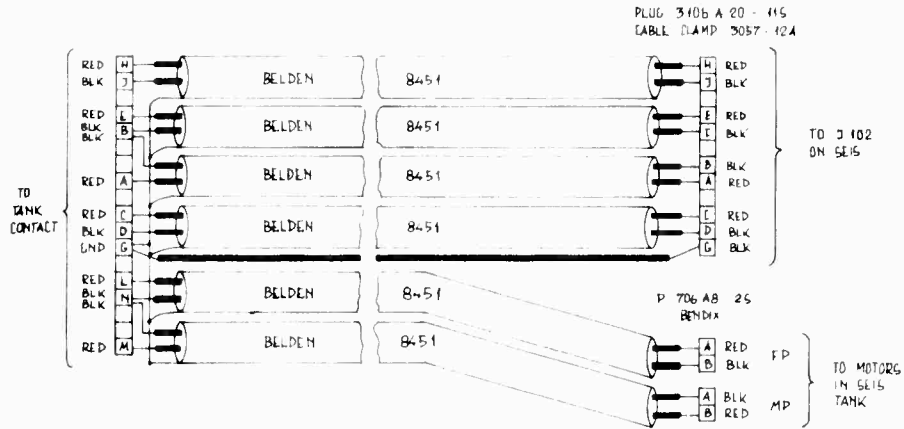

Figure 2.17 Internal LP tank connections, horizontal seismometer

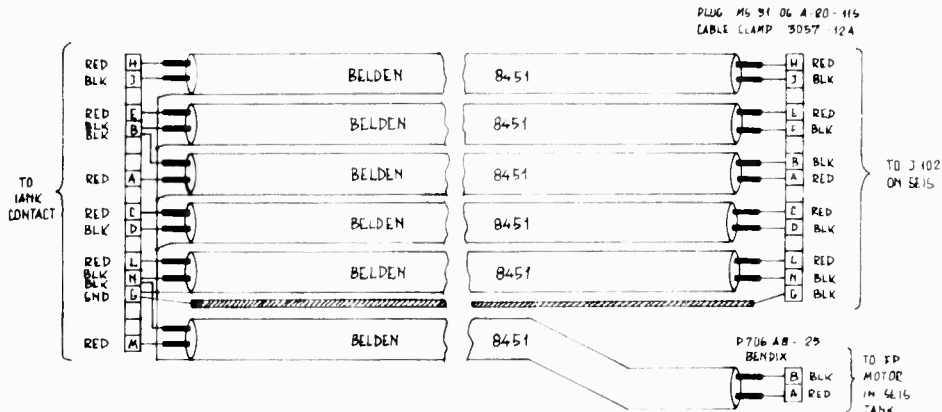

Figure 2.18 Internal LP tank connections, vertical seismometer

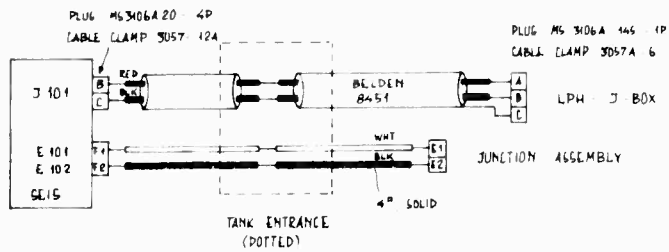

Figure 2.19 Data and damping cable, LPV installation

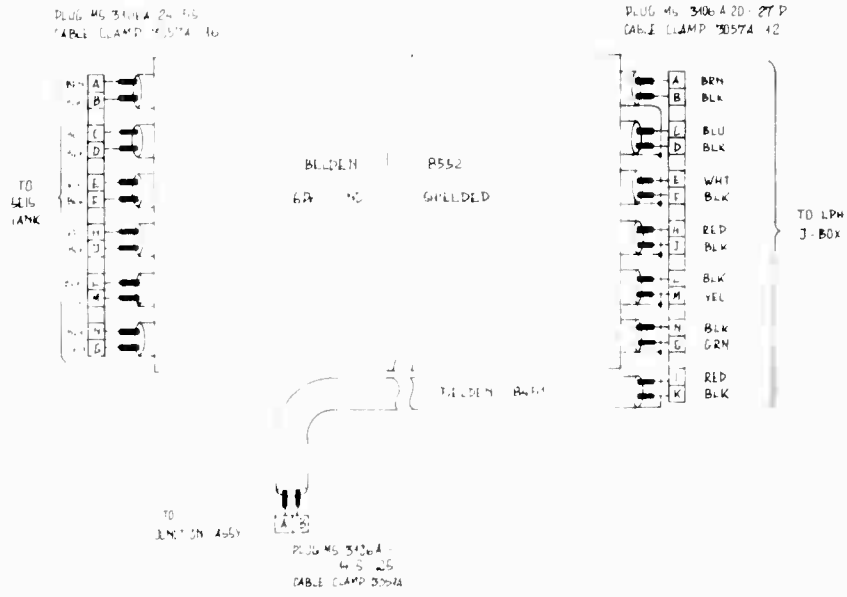

Figure 2.20 LPV cable connection

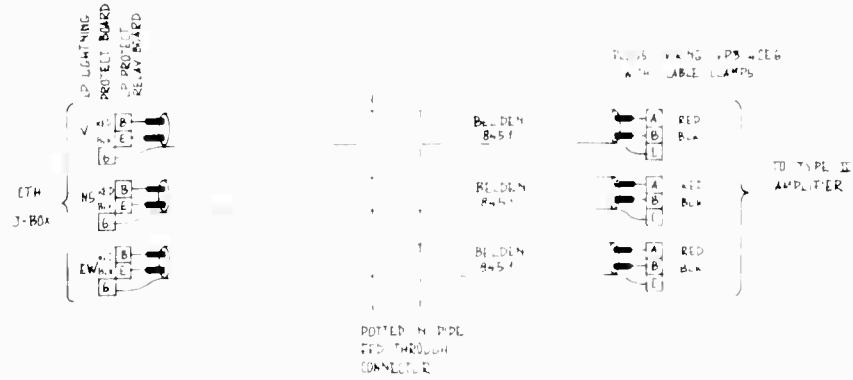

Figure 2.21 LP junction box to amplifier connection in DRC

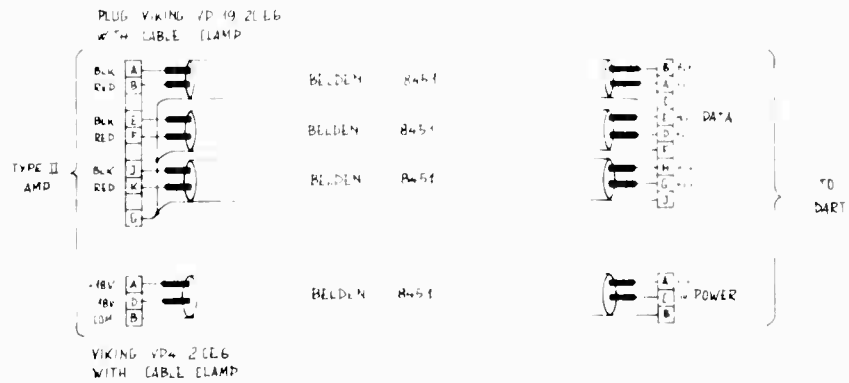

Figure 2.22 Data and power cable amplifier to LP recorder (DART) in DRC

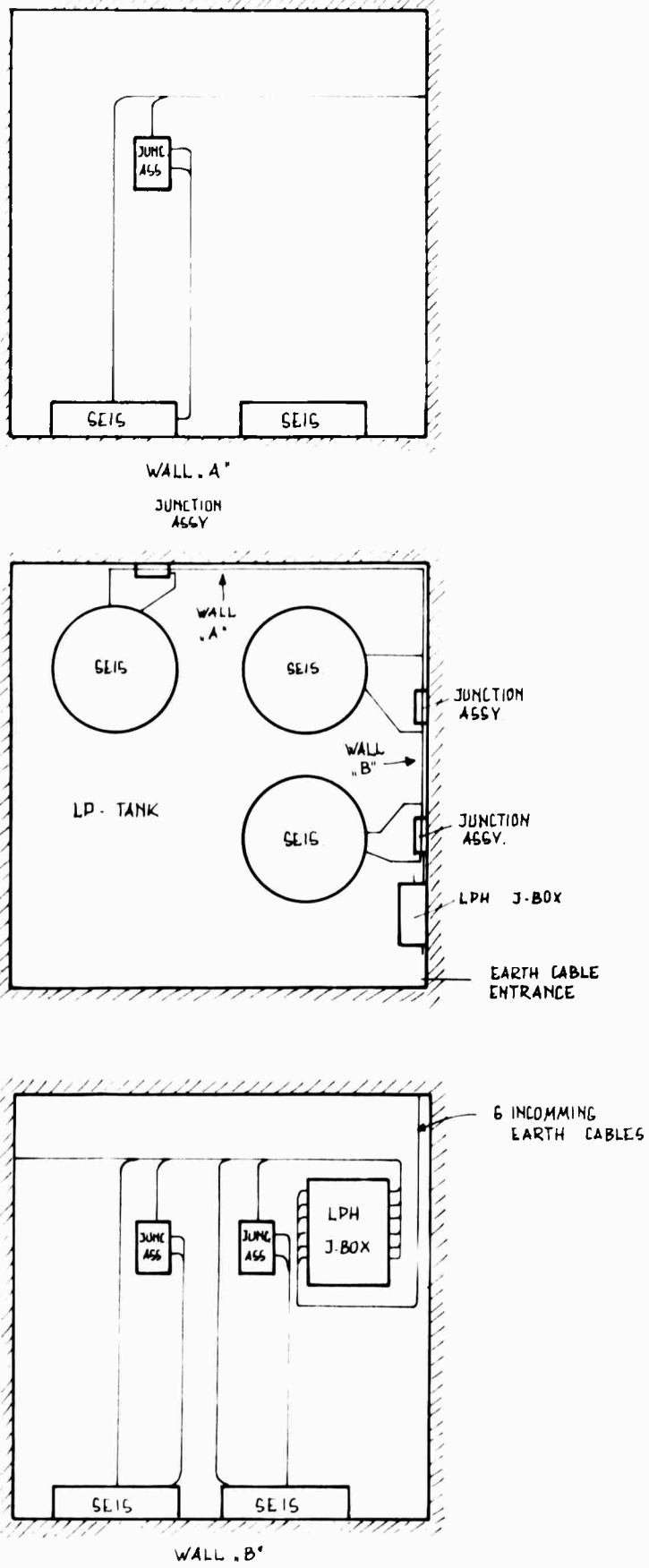

Figure 2. 23 Cable layout in LPV

Both instrument types have three coils, signal-, calibration- and damping-coil, and are also fitted with an electro-optical mass position monitor. The vertical transducer has an internal mass centering motor, while those of the horizontal ones are external. Finally the instruments are all fitted with an external free period adjustment motor.

#### LPV circuitry

Figure 2.16 shows the signal and power circuitry in the LPV (and also DRC). Details of the cable connections are found in Figures 2.17 - 2.22, and Figure 2.23 coarsely depicts the physical layout within the LPV.

#### LP recording equipment

Figure 2.24 presents a block diagram of the DART recording system used for LP recording at Øyer, Falldalen and Borgseter (and to some extent also for Øyer SP data). The DARTs are designed and built by LL, and are in principle similar to the Astro-data system described above. Facilities for direct or playback analog chart recording are not available.

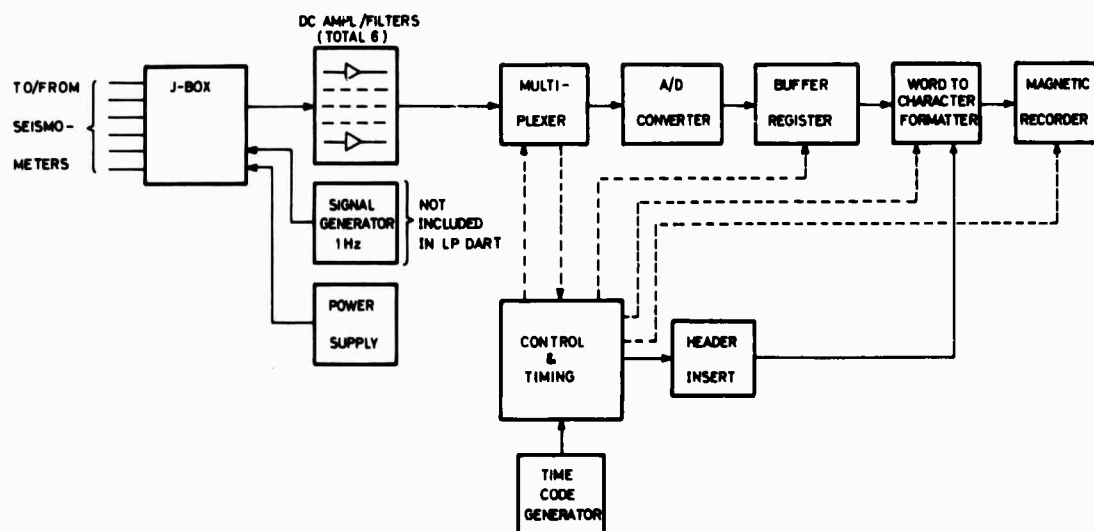

Figure 2.24 DART system for LP recording at Øyer, Falldalen and Borgseter

The incoming cables also in this case terminate in a wall junction box which contains lightning protection devices. From this box each of the data signals (maximum 6) passes through an amplifier/filter before it is sampled by a multiplexer. The sampling rate is 1 per second for the LP-DART (and 20 per second for the SP-DART). A Raytheon analog-to-digital converter converts the signals to 14-bit words which, after adding one parity bit and 3 extra sign bits, are loaded into a buffer register. After unloading from this, the 18-bit words are split into three 6-bit characters in a word-to-character-formatter and, after adding one parity bit, are recorded on digital magnetic tape. The tape transport is of the Kennedy Incremental type.

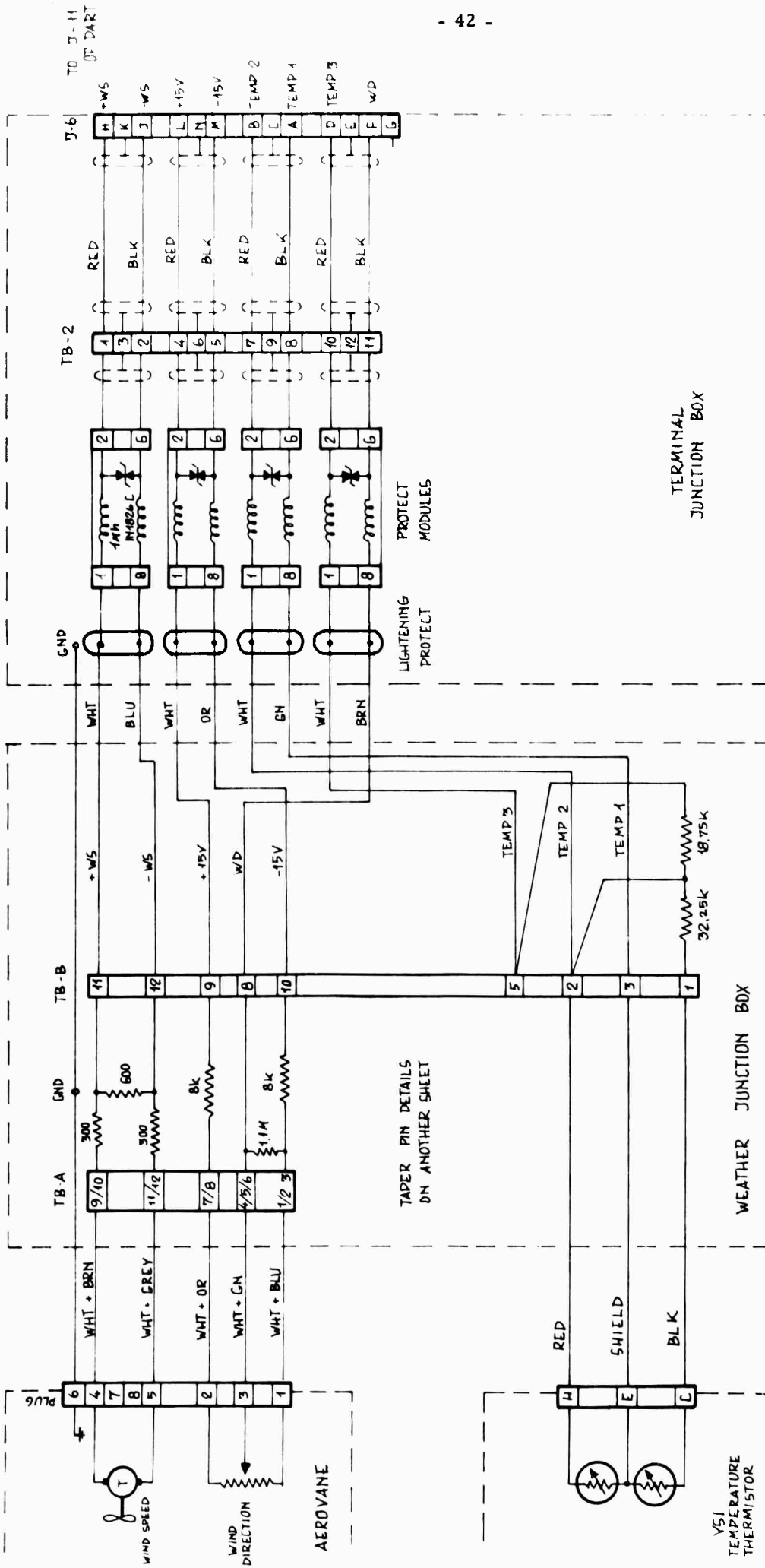

Figure 2.25 Automatic weather station at Fall dalen, wiring diagram

The DART system also contains a time code generator which serves as the system clock. The generator is of the Chronolog type, and time information is issued every 20 seconds for the SP-DART and every 10 minutes for the LP-DART and recorded on the tape. In addition the clock also controls the system as indicated by dotted lines on the block diagram. (For further details of DART system see DART manuals.)

2.11.3 Experimental noise study array

The limited depth (about 1.5 m) of the shallow holes at Falldalen would not allow use of steel "stilts" on the seismometers, otherwise they are identical to those used at Øyer subarray.

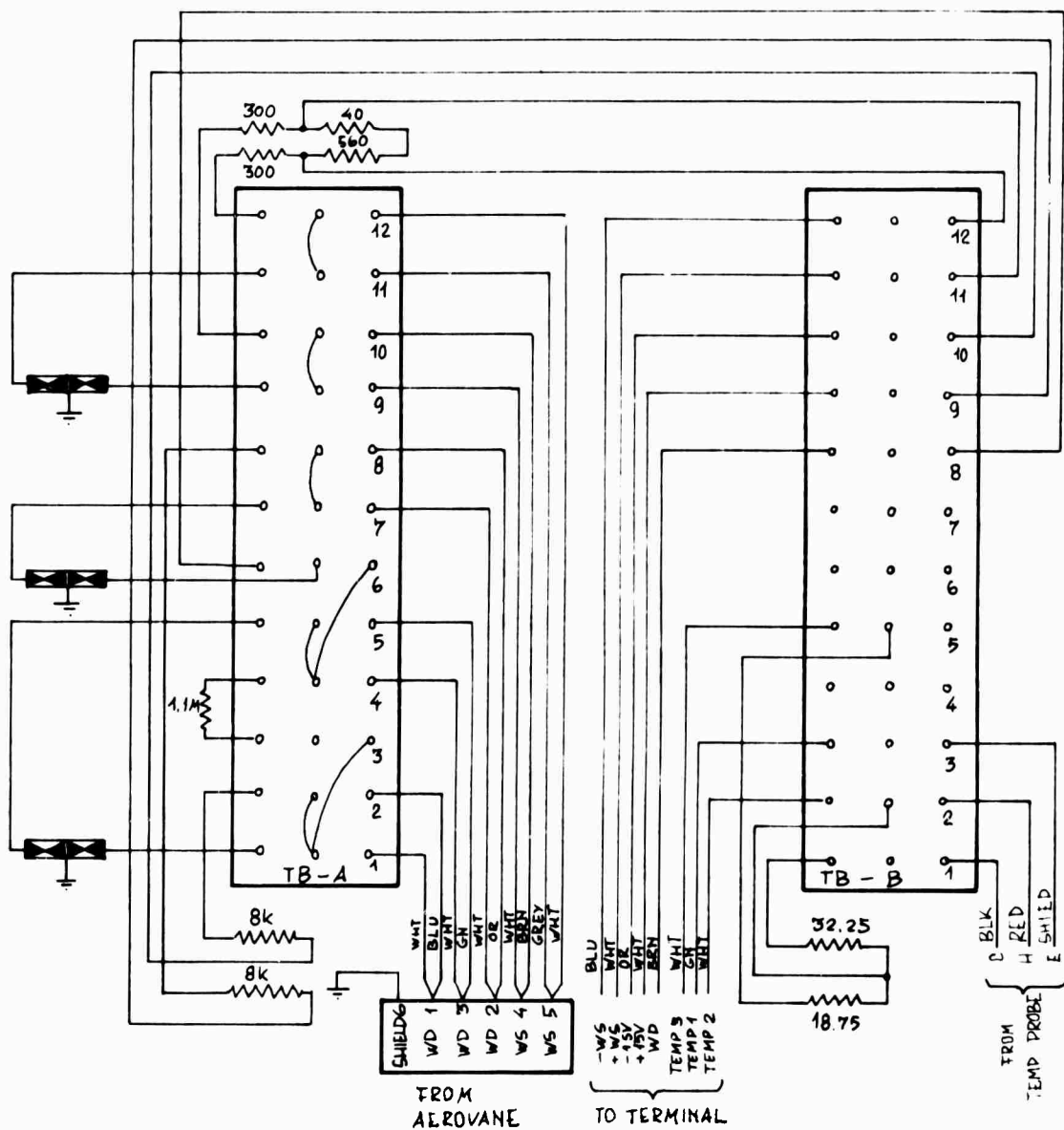

Figure 2.26 Automatic weather station at Falldalen, junction box wiring

The 60 m holes were put in to study the downward penetration of local surface noise as a function of depth. For this purpose LL were to bring in seismometers with special housings, but electrically equivalent to HS-10-1 (ARPA). The containers were equipped with radially directed, spring-loaded steel knobs which could be released from the surface and which would introduce a rigid positioning and good coupling to the casing at any depth.

A DART system would be used for the recordings. The running time for a standard 2400 ft tape reel would be dependent upon the number of channels (seismometers) used; on the average it would be of the order of 12 hours.

### 3 INSTALLATION

Full consent to implement Phase 1 of the NORSAR project was given by Norwegian authorities on 23 August. This released a series of actions prepared under the planning stage. Orders and subcontracts were first placed for services and materials considered to require the longest lead times or otherwise present the major potential delays in the time schedule for the installation.

It should be mentioned that the funding of the project was not complete by 23 August. The funding limit was \$ 250 000, - by this date and was extended by another \$250 000 on 14 September. This was reflected in delays in formal ordering of several important services.

The most urgent items concerned first of all the Øyer subarray and comprised the final siting of SP sensors and LPV locations (2.3), detailed trenching routes survey and staking, drilling and casing, trenching and signal cable delivery. As a whole, at this time most of the work and material items had delivery periods in conflict with the expressed target of a fully operational system before winter conditions put an effective stop to further installations. It was obvious that only a very late onset of the frost and snow period would make possible even near fulfilment of the target.

The following sections present a brief narrative of the installation phases, with emphasis on bringing out special problems encountered when installing a system of this type under Norwegian conditions.

#### 3.1 Subcontracting

A list is given below of firms (institutions) which were given main contracts or orders. The extent of the orders and the background for choice of the firms are briefly outlined. Concerning dates of orders mentioned in the following, it should be mentioned that the formally written orders often were preceded a couple of days by an oral one.



### 3.1.1 Services

- a) Firm: Norconsult A/S, Consultant Engineers, Høvik (Oslo).
- Contract items: Survey and siting of boreholes, LP and CT vaults and data recording centers. Control of drilling and casing, drilling reports. Design of LP and CT vaults, bid invitation and evaluation, construction control. Planning of data recording centres for signals connections, power, water and sewer. Coordination in the field. System check out.
- Basis of choice: NDRE experience and information.
- b) Institution: Fjernkabelkontoret, Telegrafstyret (Long Distance Office of the Norwegian Telegraph Administration Board), Oslo.
- Contract items: Routing and staking of approx 100 km of trenches, trenching and cable-laying, splicing, backfill, check of cable continuities.
- Basis of choice: NDRE information. Time for procurement of bids and bid evaluation not available.
- c) Firm: Norsk Dypbrønnsboring (Norwegian Deep Drilling Co), Sandvika (Oslo).
- Order content: Drilling and casing of 20 vertical boreholes at Øyer, each 15 meters in bedrock, and 2 deep holes at Falldalen, each 60 meters in bedrock. Installation of WHVs, retainer rings and covers at Øyer and for the two 60 m holes at Falldalen.
- Basis of choice: NDRE inquiries and price evaluations, recommendations from US consultant.
- d) Firm: Noratom - Norconsult A/S, Oslo.
- Order content: Design (modifications) and fabrication of 22 well head vaults including retaining rings and coolie hats, 25 amplifier and 25 junction boxes. Drawing of cable connection diagrams for WHVs and DRC. Installation of amplifier and junction boxes and installation of SP seismo meters.
- Basis of choice: NDRE experience and information. Time for competitive bidding not available.
- e) Institution: Moksa Kraftanlegg (Moksa Power Co), Tretten.
- Order content: Power supply, 220 V, 15 kW, to DRC Øyer.
- Basis of choice: MPC only authorized supplier in area (monopoly).
- f) Institution: Stange E verk (Stange Power Co), Stange.
- Order content: Power supply, 220 V, to DRC Falldalen.
- Basis of choice: Monopoly.
- g) Institution: Sagnfossen Kraftanlegg (Sagnfossen Power Co), Nybergsund.
- Order content: Power supply, 220 V, to DRC Borgseter.
- Basis of choice: Monopoly.

- h) Institution: Telegrafverket, Lillehammer stasjon (Lillehammer Telegraph Station of the Norwegian Telegraph Administration), Lillehammer.
- Order content: 14-pair telephone cable connection NTA network to DRC Øyer, telephone and telex installation and subscription.
- Basis of choice: Monopoly.
- i) Institution: Telegrafverket, Hamar stasjon (Hamar Telegraph Station of NTA), Hamar.
- Order content: Telephone installation and subscription.
- Basis of choice: Monopoly.
- j) Institution: Telegrafverket, Elverum stasjon (Elverum Telegraph Station of NTA), Elverum.
- Order content: Telephone installation and subscription.
- Basis of choice: Monopoly.
- k) Firm: Lars Grønvold Entreprenørforretning A/S (LG Construction Co), Lillehammer.
- Contract items: Construction of LP and CT vaults and DRC house foundation, Øyer.
- Basis of choice: NC inquiries and recommendation.
- l) Firm: Hagen og Godager Entreprenørforretning (H&G Construction Co), Stange
- Contract items: Construction of LP vault, erection of DRC house foundation, installation (mechanical) of shallow holes inclusive casing and WHVs at Fall-dalen.
- Basis of choice: NC inquiries and recommendation.
- m) Firm: Lauritz L Hanstad Entreprenørforretning (LLH Construction Co), Nybergsund.
- Contract items: Construction of LP vault, erection of DRC house.
- Basis of choice: NC inquiries and recommendation.

### 3.1.2 Materials

- a) Firm: Standard Telefon og Kabelfabrik A/S (Standard Telephone & Cable Company Ltd, an ITT affiliate), Oslo
- Order content: Delivery of 100 km 12-pair signal cables (specifications in Appendix 2).
- Basis of choice: Price and delivery time comparisons with two US suppliers.

- b) Firm: Moelven Brug A/S (Moelven Works), Moelv.
- Order content: Delivery of a three-section house for Øyer DRC, a unit 75A for Falldalen DRC, and a unit 39A for Borgseter DRC.
- Basis of choice: NDRE information. Prefabricated units imperative considering time schedule.

### 3.2 Drilling and casing of boreholes

#### 3.2.1 General techniques

Two drill types were used, a model Stenuick Record HS5 compressed air drill (Figure 3.1) for drilling in rock and a model Perfo 66 percussion drill (Figure 3.2) for penetration of overburden in cases where large depth to bedrock made it impossible to expose the rock surface by digging or scraping off the masses by a tractor back-hoe. Drilled holes in overburden were lined with an extra 200 mm (8 in.) OD tube casing to hold off the loose sediments while rock drilling was in progress. Rock hole diameter was nominally 160 mm; in practice the drill bit diameter was often somewhat less (say 158 mm) due to wear.

The casing steel tubes (140 mm OD, 132 mm ID) were delivered in lengths of max 10 m. Conical steel plugs (Figure 3.3) for sealing of casing bottom ends were manufactured and welded to the tube at the driller's workshop.



Figure 3.1 HS5 compressed air drill



Figure 3.2 Perfo 66 percussion drill

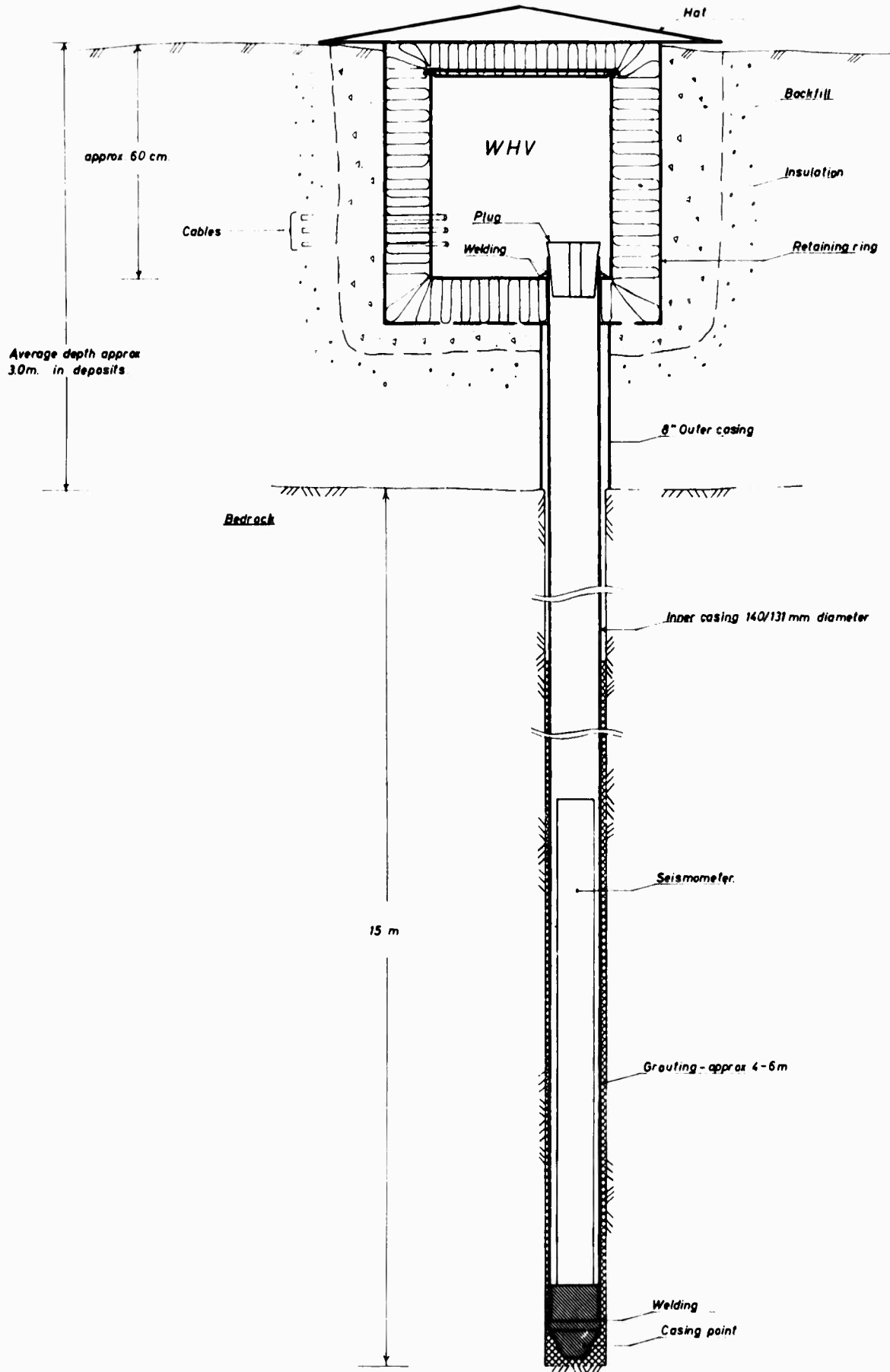

Figure 3.3 SP seismometer hole, complete with casing and WHV

Subsequent to the completion of drilling, removal of the drill rig and cleaning of the hole for mud, a provisional tube scaffolding was erected to enable positioning of the sealed bottom tube length over the hole.

Cementing to rock was specified for the lower 4 m of the casing (Figure 3.3). A batch of mortar (consistency of flowing concrete grout, specifications in Appendix 4.1) of volume equivalent to the void between hole walls and casing over the lower 4 m (some 30 - 40 liters) was filled into a cylindrical container fitted with a spring-activated ball valve, lowered into the hole and emptied at the bottom. This procedure was followed in order to suppress any ground water present.

After completion of the injection operation, the first casing length was lowered until approx 1 m of the upper end protruded from the hole and was then locked in this position. Another tube length was positioned coaxially on top of the first and welded to this. A pressure test was done to secure the sealing quality of the welding. (The bottom seals were pressure tested at the driller's workshop).

The final operation consisted in lowering of the casing until the seal cone rested on the bottom of the hole. The casing would then be locked in position until the mortar had solidified. Cutting of the protruding tube to the desired length completed the operations.

The techniques used for installation of the 60 m holes at Falldalen did not deviate principally from the ones above except for the cementing procedure (Figure 3.5).

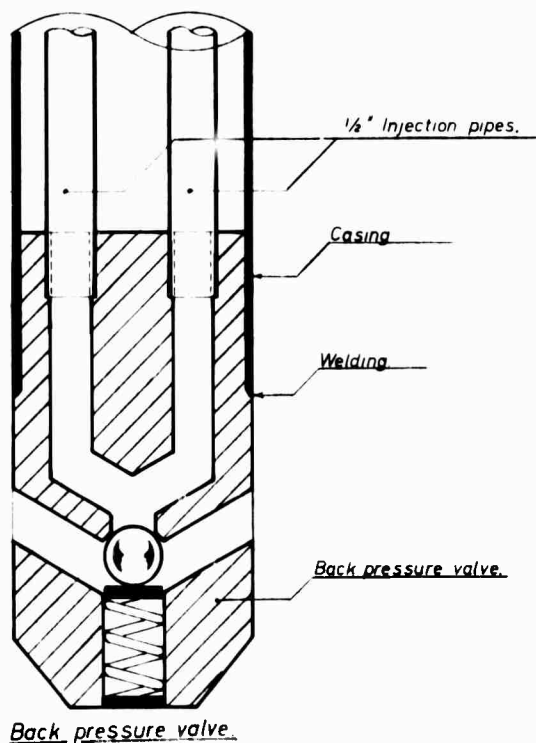

Complete cementing from bottom to surface was specified here; pre-filling of grout followed by tube intrusion would obviously be an impossibility both by reason of forces necessary and also because of the time factor involved (premature grout solidification).

In this case a special bottom casing seal cone (Figure 3.4) fitted with a penetrating conduit was used. A spring-loaded ball valve blocks this channel under normal conditions, but opens when the internal to external overpressure exceeds a certain limit. Two small-diameter tubes are connected to the cone channels and follow the interior of the casing in its full length.

Figure 3.4 Ball valve cone for cementing 60 m casings

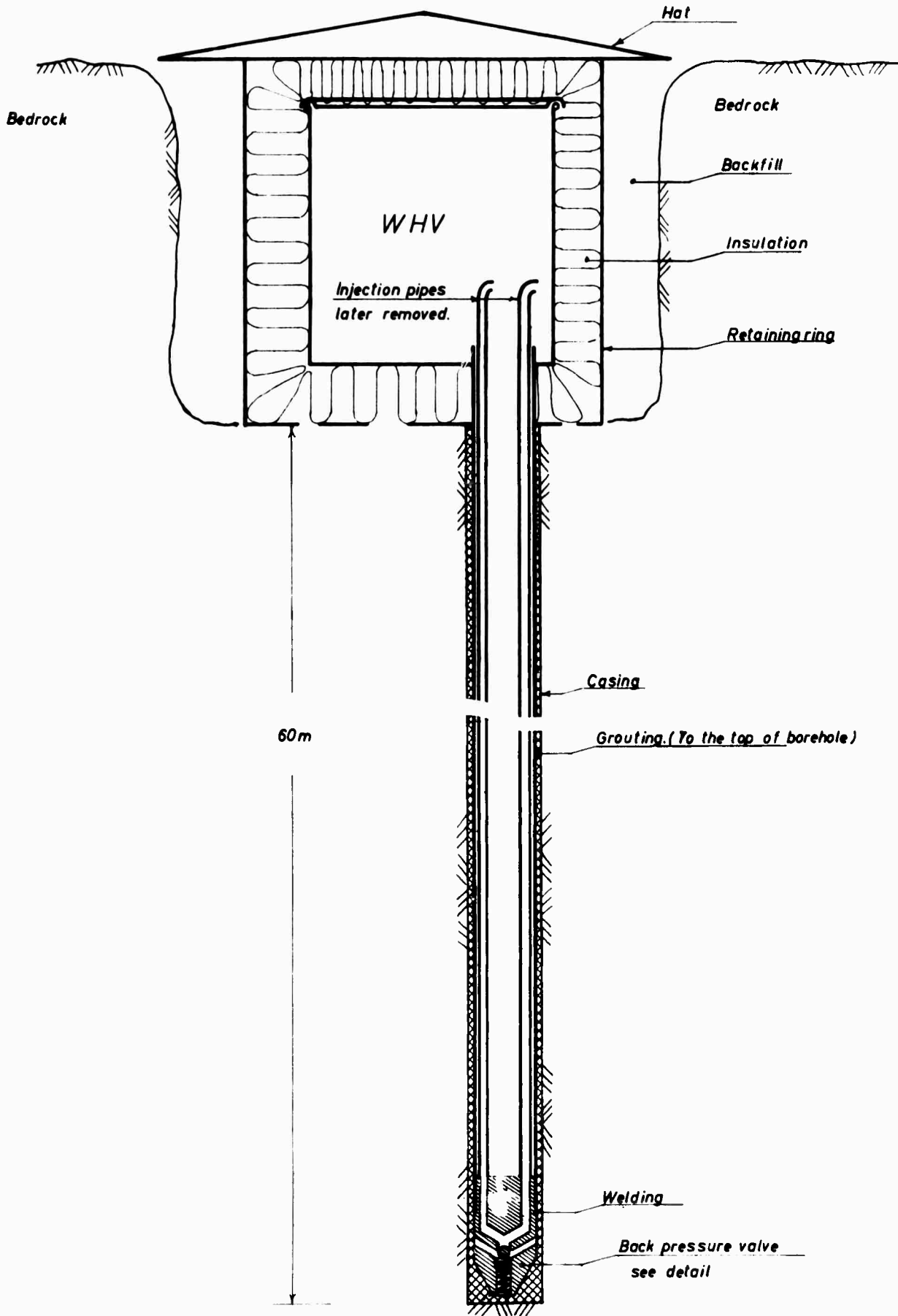

Figure 3.5 60 m SP seismometer hole, injection tubes not removed

The sequence of operations in this case starts by the lowering of the casing until the cone rests at the hole bottom. Next the U-formed inner tubes are filled with water and one of the tube ends is blocked. Grout is now forced down the other under pressure. The valve opens and the grout will eventually pass through it and into the space between the casing and the rock hole wall. The pressure is released when the grout rises above the rim at the surface. The valve locks and keeps the grout from re-entering the casing. The other transport tube is reopened and both of them are cleaned by a water stream. Finally both tubes are unscrewed from the seal cone and may be reused.

### 3.2.2 Progress of work

Drilling operations at Øyer started 13 September on hole 10Y (1) and soon after on the three holes of the A-leg, 1A1(8), 1A2(9) and 1A3(7), Figure 2.13. Already at an early stage the rate of progress in general and especially that of trenching strengthened the doubts as to the chances of completing the whole sub-array before winter. A priority list had to come into effect. The underlying principles for this were seismological and practical preferences, and it called for completion of as many full diameters (combination of two radially opposite legs) as possible. The diameter A-D was to be accomplished first, followed by C-F, the F-leg being a natural retreat route out of the area.

The drilling and casing proved not to be the most limiting part of the operations. When they were ordered to be stopped on 13 November, 17 of the 20 holes were completed, one hole (1E2(15)) was only partially drilled, while two others (1B2(6) and 1B3(4)) were not cased (Figure 2.13).

The drilling and casing operation could undoubtedly have been completed, but the status of the trenching operations gave no reason for continuation.

Drilling of the two 60 m holes at Falldalen started week 46 (13-18 November). The last of them was ready by 12 December.

### 3.2.3 Special problems and experiences

On an average the rate of progress was lower than expected and presupposed by the driller. He encountered conditions different and more difficult than expected and probably was not experienced for a rush job of this scale. The difficulties may be summed up as follows:

- a) Not enough transport equipment was brought in by the driller, and coordination of that available left something to be desired. The driller may have been under a delusion as to the extent of transport produced by the employer, and certainly underestimated the need for transport in general.
- b) The drilling operations had a slow start due to lack of drill bits. This should not be primarily blamed on the driller. Drill bits of the right size were obviously difficult to obtain at short notice, and a customs strike in Belgium added to the difficulties.
- c) At some of the holes the driller met problems that had to do with the consistency and depth of the overburden.

At hole 1A1(8) most of these problems were experienced. New attempts had to be made because of

- high ground water table and a flow that could not be overcome by pumping
- the layer of overburden was too thick
- boulders in the sediments interfered
- there were difficult faults in the rock, at one place there was a sand fault that led to collapse of the hole

Work at 1A1(8) started 17 September and the grouting was done by 31 October.

Appendix 4.4 contains the controller's drilling reports, a brief survey of statistics of the operations, and other data and drawings of relevance to the operations.

### 3.3 Well head vaults installations

#### 3.3.1 Production and delivery of vaults and vault electronic equipment

The equipment was ordered 5 September. Delivery dates were stipulated as 15 October for the drums with retainer ring and cover, and 15 November for the electronic boxes. Delays in the delivery of electronic components and mechanical details from the US led to changes in the progress time-table, but the final delivery dates were largely kept.

#### 3.3.2 Installation of the vaults, retainer rings and covers (coolie hats)

This job, initially assigned to the equipment manufacturer and already in the planning stage, was transferred to the driller, as this was obviously a more expedient arrangement. The vault may be looked upon as the upper part of the casing, the driller would furthermore have the welding and digging equipment at hand at the suitable moment.

No particular difficulties arose in connection with these installations. The progress of work was entirely subjected to the progress of the drilling and casing operations. The techniques used were conventional.

#### 3.3.3 Installation of amplifier and junction boxes - signal cables connection

The installations (carried out by the manufacturer) started 6 November at Øyer and were completed by 8 December (Figure 3.6)

The Falldalen installations were performed in the period 10 - 16 December.

The installations met no major difficulties beyond inconveniences produced by the weather (frost and snow). The rate of progress was tied to the casing operations.



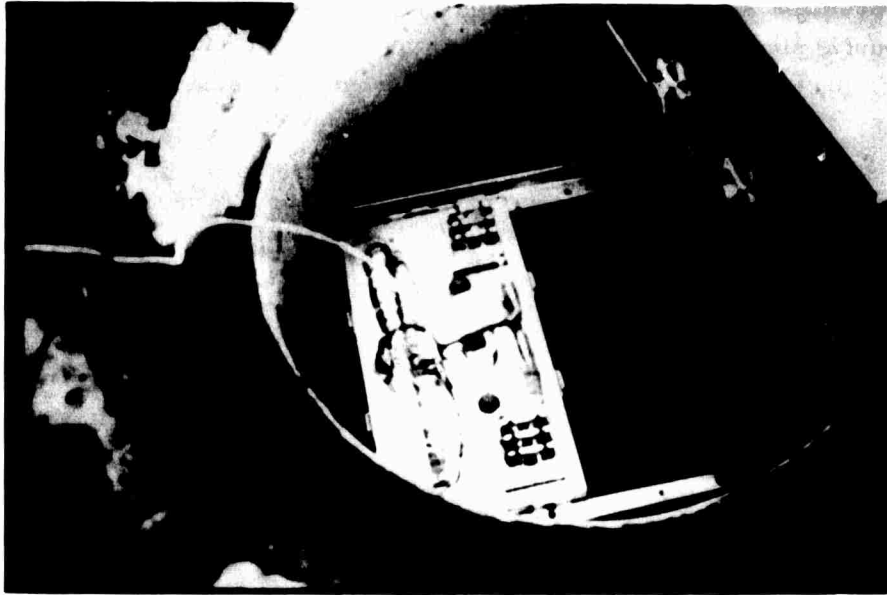

Figure 3.6 Installation of amplifier and junction boxes

### 3.4 Trenching

#### 3.4.1 General techniques

The techniques used were those adopted by the LDCO (NTA) from experience in trenching of coaxial cables in similar terrain. Most of them were conventional, tractor back-hoe digging in sediments (Figure 3.7), blasting of the trench through areas of exposed bedrock and hand digging where this was made necessary by the terrain.



Figure 3.7 Tractor back-hoe

A method of simultaneous trenching and cable-laying using a capstan pulled, sled-mounted plough was tried in marsh areas. This technique did not work satisfactorily. Bushes and lichen would collect in front of the sled and force it up from the soil. Large boulders in the soil had the same effect, and the method had to be abandoned and replaced by conventional excavation methods.

### 3.4.2 Progress of work

The ordering of routing and staking at Oyer was done 25 August, and the formal order for the trenching was placed 15 September, succeeding an oral message of intent by a couple of weeks.

Routing and staking of trenches started 4 - 5 September at Oyer and trenching began 11 - 12 September.

As of 1 November, the trenching and laying of the 14 pair communication cable and the power cable from DRCs to their respective pole line termination points (2.10.1, 2.9.1) had been completed as well as the seismic cable diameter A-D plus the stretch 10Y(1) - 1C1(2), Figure 2.6.

Stop order for the trenching and cable laying operations was given 15 November, as deterioration of the working conditions effectively prevented further progress. Legs A, D, C and stretch 10Y(1) - 1F4(20) - 1F1(11) were completed, tantamount to availability of 12 out of 20 SP seismic points (Figure 2.13).

### 3.4.3 Special problems and experiences

Not unexpectedly, trenching proved to be the crucial part of the whole installation and in the end became the one factor responsible for the overall status at the end of the 1967 working season.

It should be kept in mind that ordering was done so late that specific delivery dates could not be enjoined upon the trencher. It is doubtful whether any contractor would have accepted delivery guarantees under the circumstances of that time.

On 23 September, some 13 km of trenches had been dug. As no cable had been delivered, LDCO was at that moment reluctant to force the work for fear that cave-ins of the open trenches would make necessary extensive recleaning before cables could be laid.

The situation soon reversed, however, as SFK started deliveries and was able to increase the delivery rates considerably (3.5).

As conditions developed, the open trenches (Figure 3.8) seemed to stand well for long periods. This fact should to some extent be related to very favourable weather conditions during the fall months.

For some time the rate of progress was not considered satisfactory by NDRE. Conferences with LDCO resulted in an increased effort; and as of 16 October, four additional tractor diggers (3 on site earlier) were brought in.

The general impression was that LDCO was oriented to the usual practice of caution and thoroughness in installation of communication connections. This may well be the best approach when installing vital long distance links under conditions of limited funding. NDRE may perhaps be blamed for not being able to convey to LDCO strongly enough and early enough that economic considerations in this case would have to be subdued somewhat in relation to urgency.



Figure 3.8 Open trench

### 3.5 Cable delivery, laying and splicing

#### 3.5.1 General procedures and techniques

The choice of cable is discussed in 2.6.2, and the specifications (including testing specifications) are found in Appendix 2.1.

The cable-laying operations were conventional, using tractor-pulled cable drum trailers (Figure 3.9). A continuous row of impregnated wooden lists were laid along the bottom centre line of the joint comm/power trench to secure positive separation of the two cables.



Figure 3.9 Tractor-drawn cable trailer

During back-filling cable ends (with necessary overlap) were brought up to the surface and a bit of trench left open. The splicing method is described in Appendix 2.2.

### 3.5.2 Progress of work

100 km of seismic cable were formally ordered on 24 August, most of the preparations for the set up of the production line and subbordering of cable materials had then been done at the firm's own risk. The delivery time quoted for the first batch was some 6 - 7 weeks upon receipt of order, i.e. about week 41. The delivery schedule was (prior to 21 September) quoted as:

5 km of cable	week 40
5 " "	" 41
25 " "	" 42

On demand from NDRE this was per 21 September revised to:

15 km	week 40
10 "	" 41
25 "	" 43
25 "	" 44
25 "	" 44/45

Splicing of the cables started the last days of October, using one team. As this effort was obviously not sufficient, other groups were put to work at NDRE's request. This work was completed 22 November and did not delay the overall installation rate.

### 3.5.3 Special problems and experiences

STK deliveries proceeded smoothly and the firm at times went out of its way to comply with the wishes of NDRE.

The cable-laying met with no serious troubles except for a limited stretch of power cable. While stretching this a length of the cable exceeded the tensile strength, resulting in internal ruptures not discovered until continuity tests were performed (3.7.1b).

The signal cables were supposed to run through the CTV, leaving a loop of 6 m of each cable within the vault. As these coils would have left a minimum of space for the vault installations to come, the local supervisor decided to run the cables outside the vault, leaving the necessary surplus lengths close to the vault.

## 3.6 LP and CT vaults

### 3.6.1 General techniques

The methods of construction were conventional. The bedrock was exposed by backhoe excavation and the rock surface cleaned for loose stones and soil. An outer



Figure 3.10 Exposed bedrock, outer mould under erection

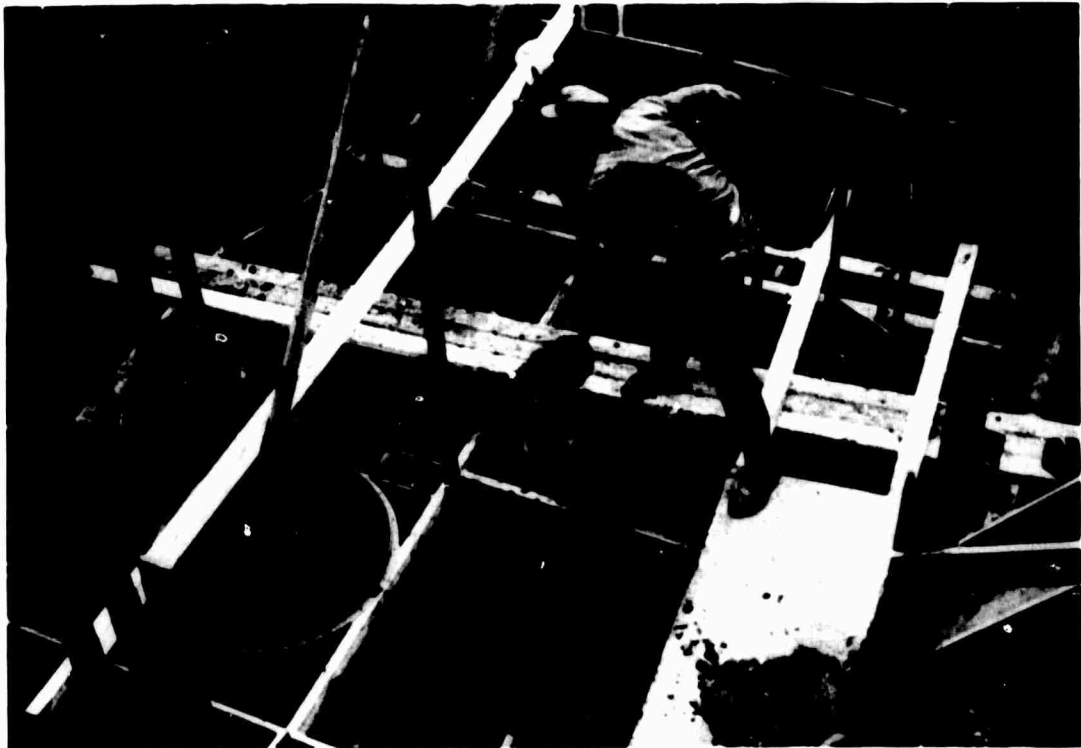

Figure 3.11 Pouring of concrete for I.P.V floor

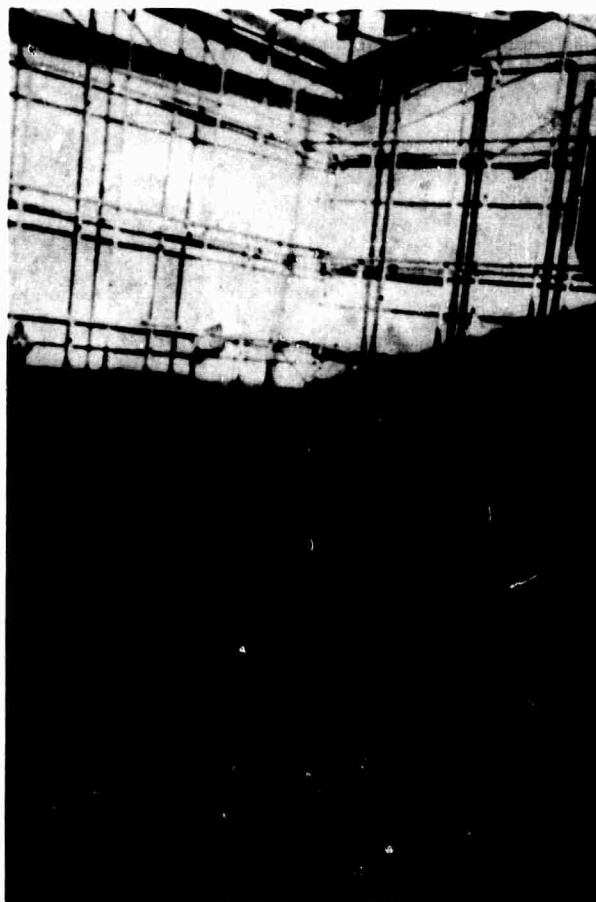

Figure 3.12 Reinforcing iron grid inside outer mould, floor hardened

wooden mould was erected (Figure 3.10) and concrete poured for the floor (Figure 3.11). The LPV and CTV procedures were identical except for the moulding of cylindrical seismometer tanks into the LPV floor.

When the floor had hardened, an inner mould was erected and concrete for the floor and ceiling could be poured in two steps (Figure 3.12). PVC water stops were fitted between floor/wall and wall/ceiling block separations.

Drainage was by means of coarse materials and drain pipes. The vaults were all placed in slopes giving easy floor level drainage.

### 3.6.2 Progress of work

LPV and CTV construction started weeks 39/40 at Oyer and Falldalen and week 41 at Borgseter. No technical difficulties arose. The rate of construction was satisfactory except for a delay at Borgseter due to formal objections by the local Building Council. The formalities were soon solved, and the construction was resumed 26.10 after a pause of about a week.

The LPVs at Oyer and Falldalen were completed by 1 November except for pressure testing and minor details inside the vaults. The CTV at Oyer and the LPV at Borgseter were finished early in December (Figures 3.13 and 3.14).

The general impression from building season 1967 is that construction of vaults of this type presents no problems for the contractors.

### 3.7 Data recording centres

Plats of the three centre areas are given in Figures 3.15, 3.16 and 3.17.



Figure 3.13 LPV before back-filling and erection of superstructure



Figure 3.14 CTV at Oyer, ventilation pipes not fitted

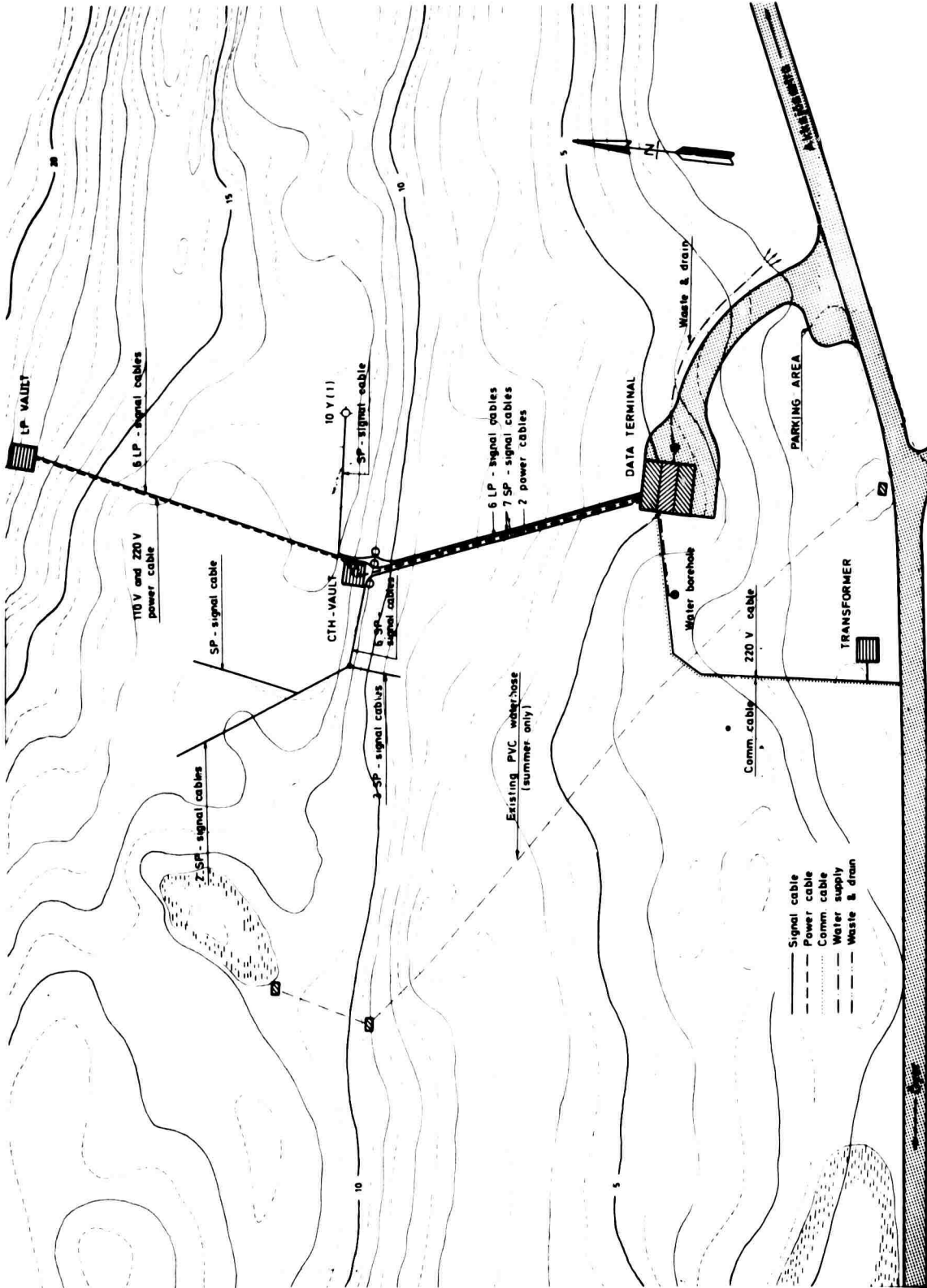

Figure 3.15 Øyer DRC area



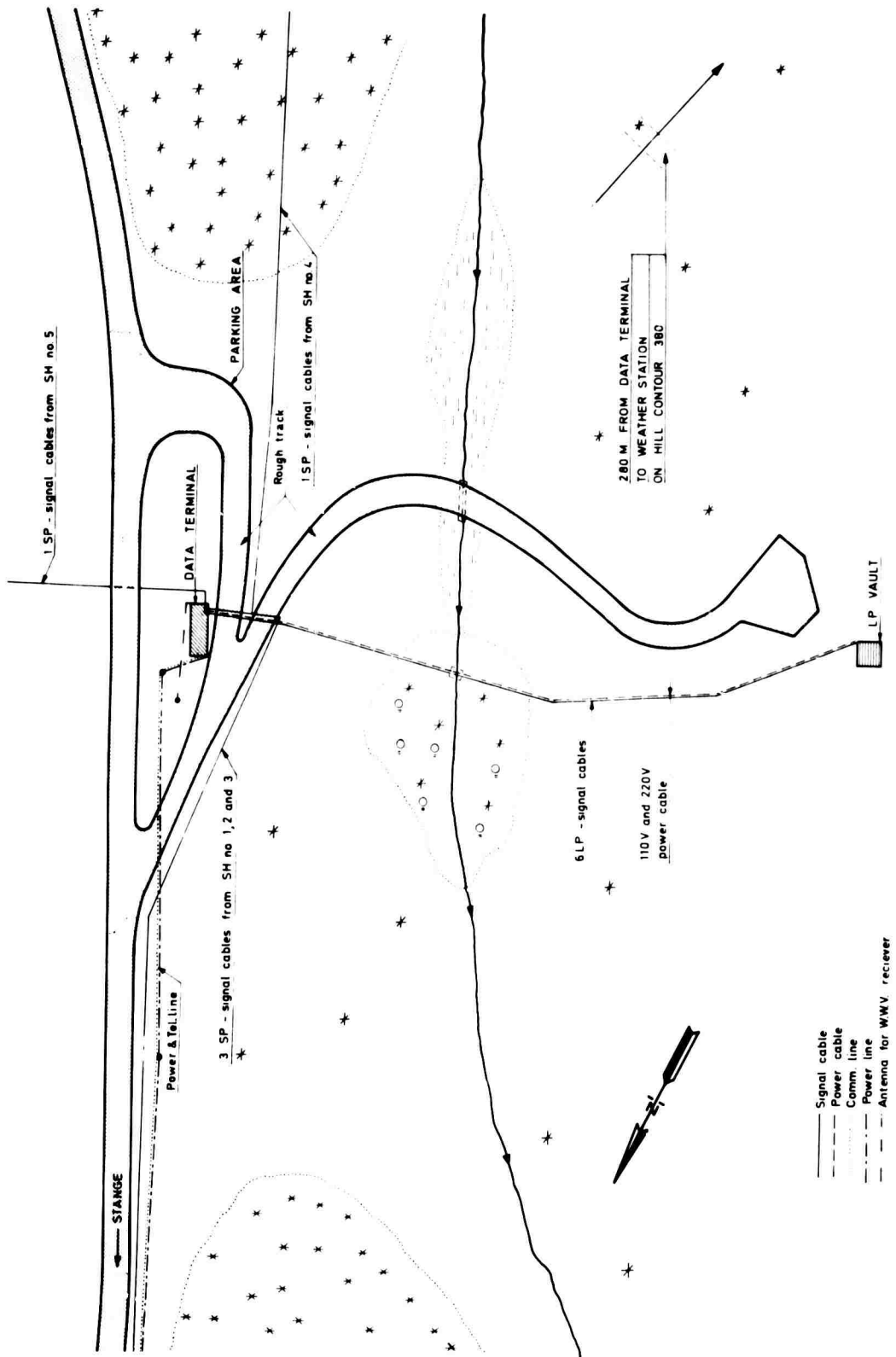

Figure 3.16 Falldalen DRC area

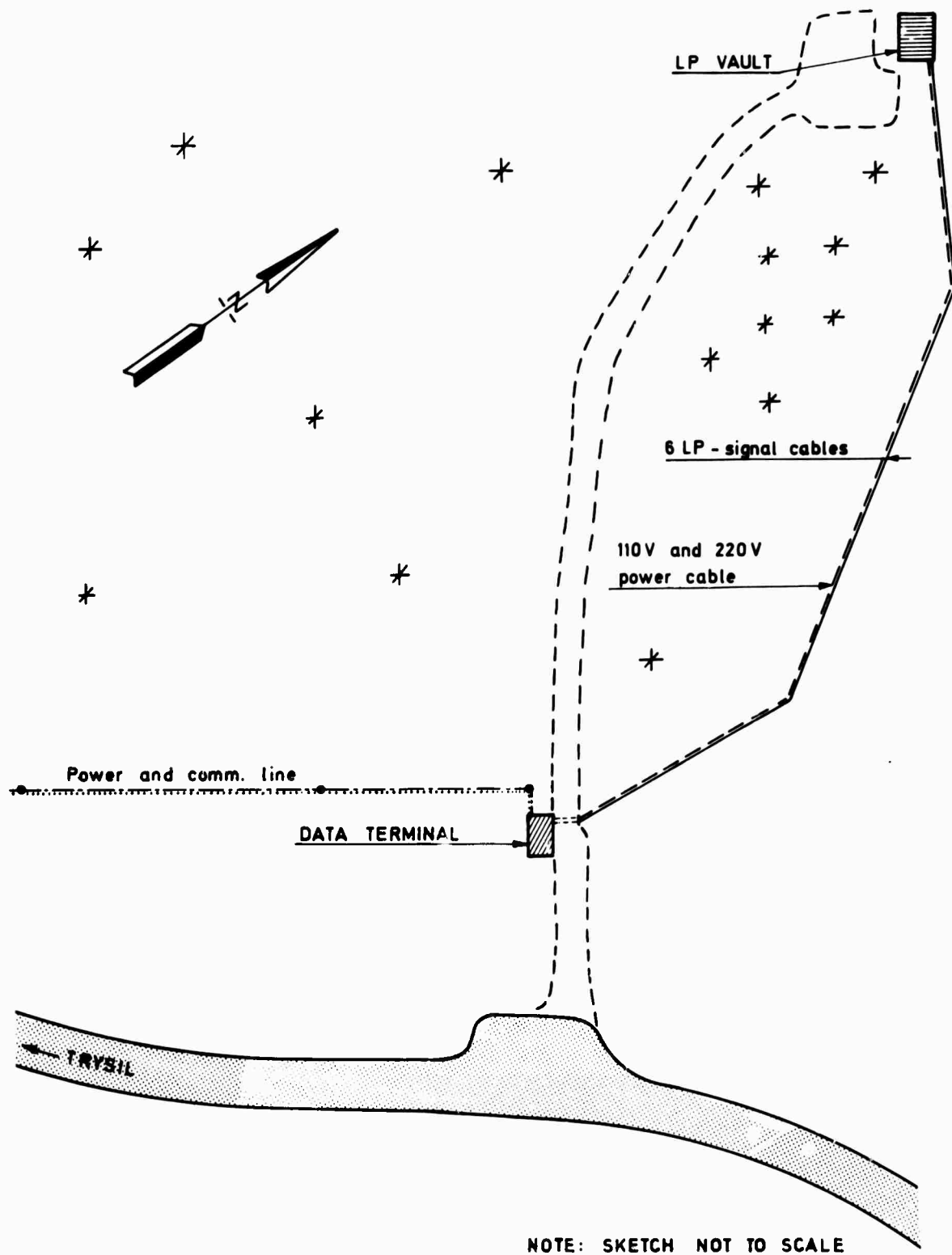

Figure 3.17 Borgsjeter DRC area

### 3.7.1 Oyer DRC

#### a) Temporary DRC building

The three section prefabricated house was formally ordered 11 September, and its erection on concrete foundation (Figure 3.18), water and waste water system inclusive, was completed by 1 November.



Figure 3.18 Erection of three-section Moelven house at Oyer  
(Refer to Figure 2.14)

#### b) Power installation Oyer - DRC wall

Planning in detail including staking of pole-line from Moksa Power Station to the pole line termination point at Vetsetra was ordered 29 August. The MPC superintendent also agreed to contact the affected land owners and obtain their permission and proposals for compensation, to make inquiries about the delivery terms for wires and poles, earth cable, 10 kV/220V transformer with hut to be placed at the DRC, termination and switching gear at the power station and other necessary equipment. When the order for the installation itself was given 15 September, most of the preparations were well in hand.

The work on the pole line started immediately and was accomplished at great pace (Figures 3.19 and 3.20). The completion of the whole link was hampered by delays in laying the cable (LDCO), the last length of which was laid week 43 (Figure 3.24).

The first test of the connection made 6 November disclosed internal breaks in earth cable due to faulty laying (3.5.3).

The weather conditions made fault finding and repairs difficult. It was revealed that the cable conductors had suffered several breaks over a length of 80 m, and had to be replaced by new cable.

On 11 November a second test showed that the link was now in working order. Parts of the link were provisional set-ups:

- The switching gear in the transformer hut (Figure 3.22, in 20 October) had not been delivered in time, thus the 10 kV leads had to be connected directly to the transformer.
- The delivery of the equipment for the termination cell in the power station was late, and the line had to be provisionally terminated in another non-exclusive cell.

Data concerning the power link are found in Appendix 5.



Figure 3.19 Power pole line in dense forest, wires not mounted



Figure 3.20 Power pole line, stretching of wires



Figure 3.21 Power cable splice

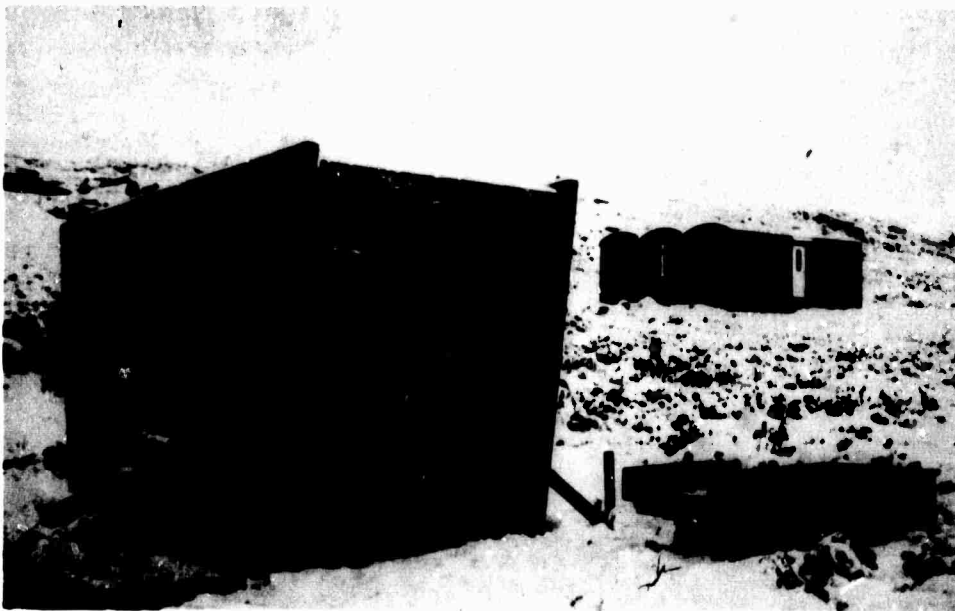

Figure 3.22 Transformer hut, Oyer

c) Power installations in DRC building

Figure 3.23 shows the mains power wiring diagram. The lighting and heating installations in the hut were part of the standardized prefabricated units and are not shown in detail.

In principle the installations are very simple, and no technical problems arose. The installations were completed by 1 December.

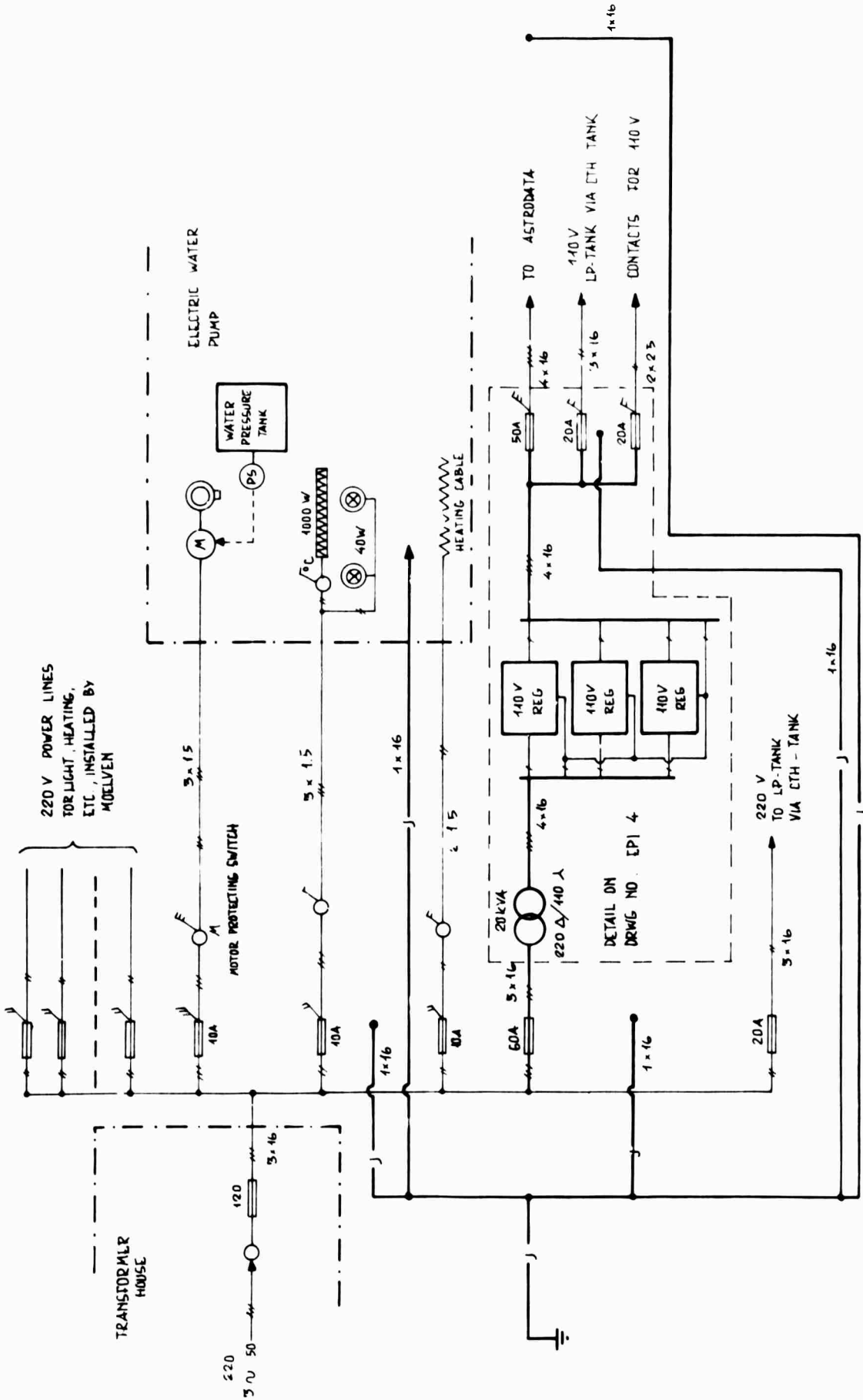

Figure 3.23 Mains power wiring diagram, Oyer DRC

d) Communication link

At a meeting 26 August in Lillehammer, the TS of NTA presented a plan for the connection from the Oyer telephone exchange to the earth cable termination point near Korsbakken (Figure 2.6). This stretch would be covered by a mixture of trenched cable (some 600 m), existing pole lines, reinforced pole lines and a couple of kilometers of new pole line. NDRE agreed to the plan and ordered the implementation.

The trenched communication cable (LDCO) was already down to the pole line on 1 November. By 1 December the whole telecommunication system was complete except for the telex at Oyer DRC. This had a very long delivery time and was not installed until 9 January 1968.

3.7.2 Falldalen DRC

A Moelven prefabricated unit type 75A was ordered 6 September and was erected on the site by 1 October (Figure 3.24).

Installation of telephone was ordered 15 September and was implemented week 40 (2 - 7 October).

Power (230 V, single phase) was ordered 6 September and brought to the DRC hut wall by 1 October. Installation within the hut was done week 41. Figure 3.25 shows the power wiring diagram for the hut.



Figure 3.24 DRC hut at Falldalen

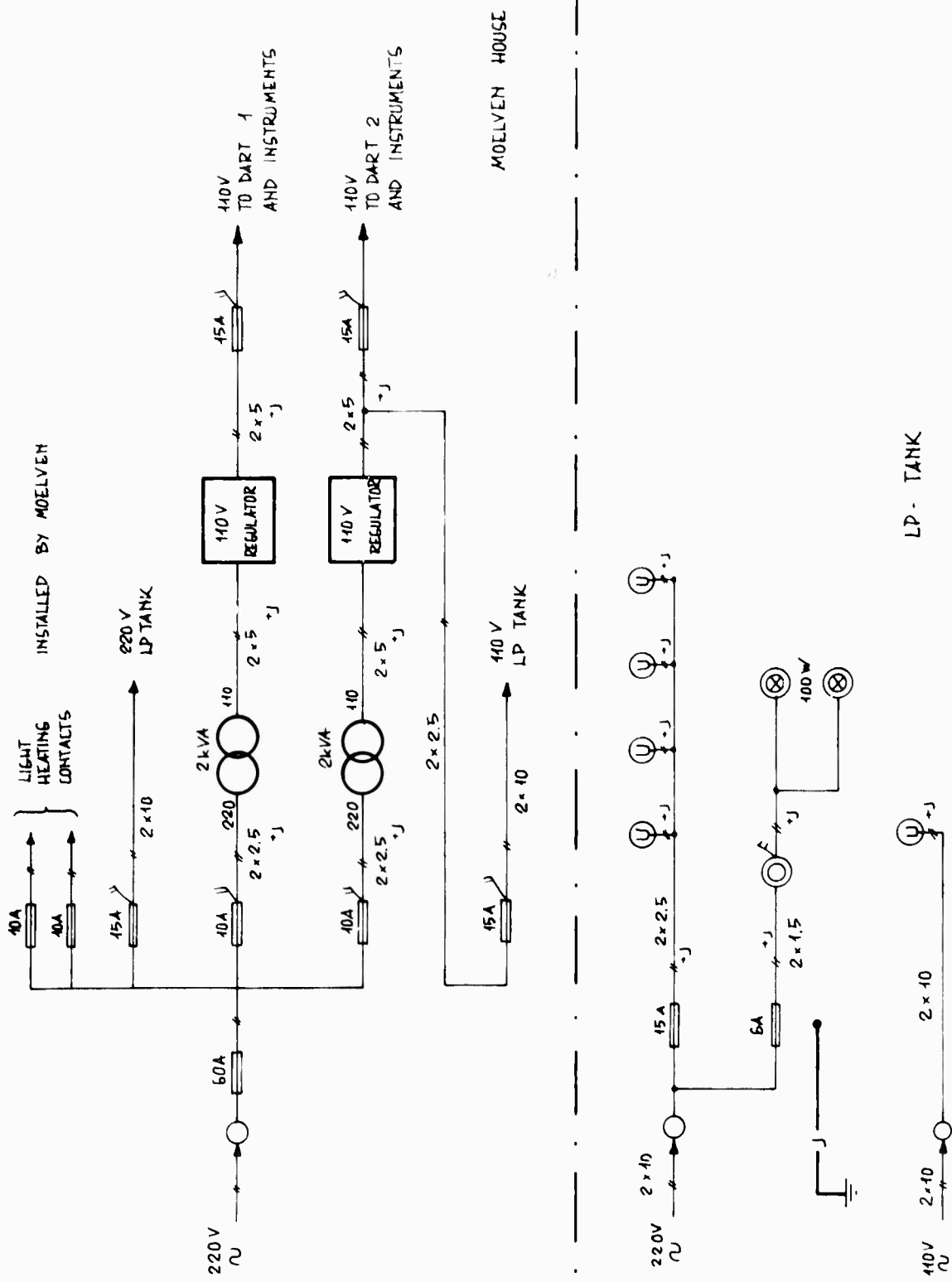

Figure 3.25 Mains power wiring diagram, Fallaldalen DRC



### 3.7.3 Borgseter DRC

A Moelven prefabricated unit type 39A was ordered 4 October and was up at the site 18 October (Figure 3.26).

Power (230 V, three phase) was ordered 28 September. The building stop imposed by the local Building Council also involved this installation. The work was resumed 26 October and the lines terminated at the hut wall 1 November. The hut installations were completed mid December. A wiring diagram is given in Figure 3.27.

Telephone was ordered 5 October and had been installed by 1 November.



Figure 3.26 DRC hut at Borgseter

### 3.8 Instruments installation and check-out

Time considerations made it imperative that installation of the technical equipment (seismometers, recorders, automatic weather station at Falldalen etc) be performed by the US consultants (E.L. Philco) or by Norwegian personnel (Noratom, Norconsult) under direct guidance from the consultants where circumstances allowed.

The Norwegian participation in the calibration and check-out phases was proportionally much higher after an initial period of familiarization with the calibration equipment and routines.

#### 3.8.1 Installation

##### a) Falldalen

Cables (6 pairs for surface interconnection), seismometers and Dart recorders arrived Oslo on 15 September, were through the customs and at the site by 30 Sep-

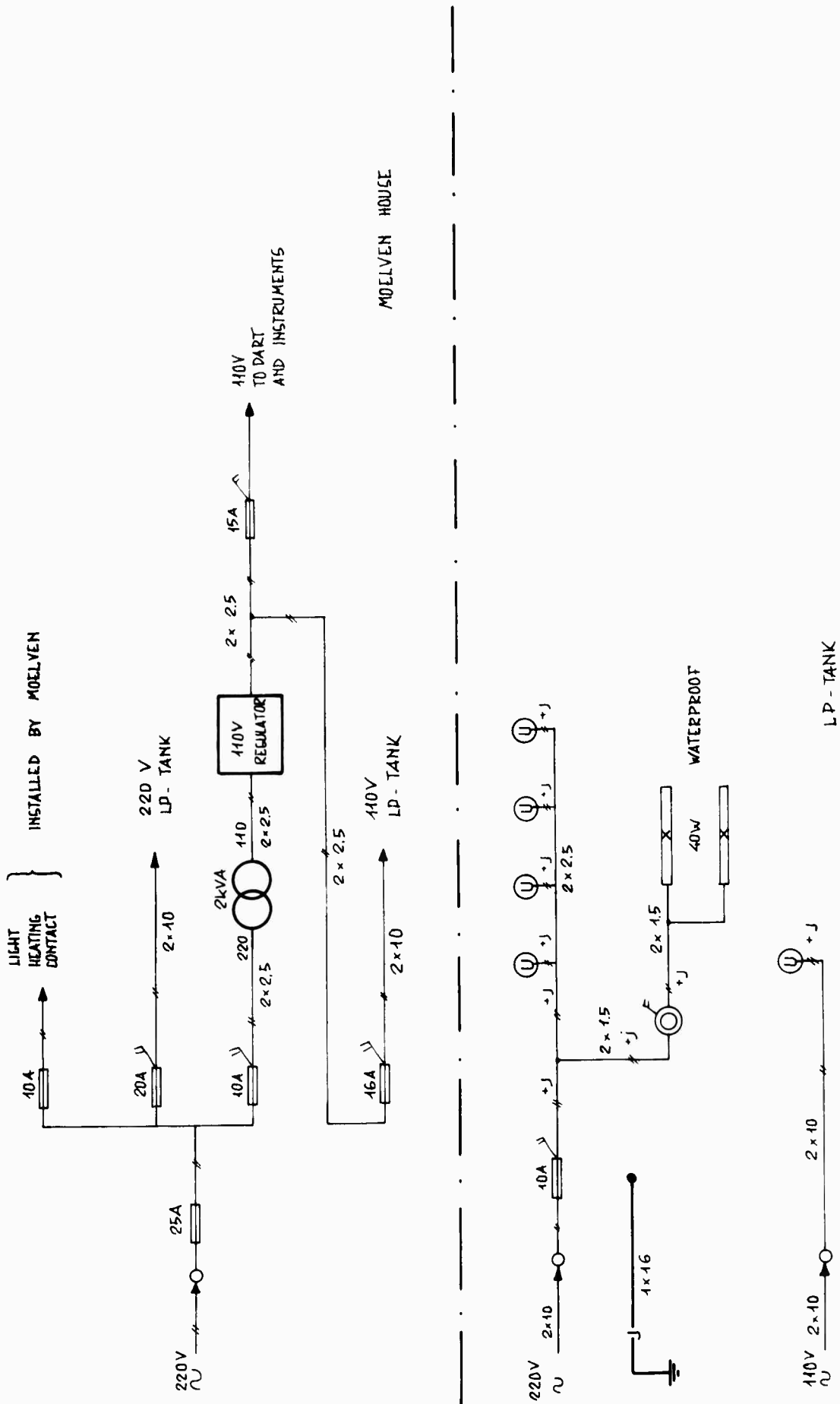

Figure 3.27 Mains power wiring diagram. Borgseter

tember. (In this period the principles of customs clearance and the standard routines were not finalized, causing some delays).

By 1 November the SP seismometers, surface seismometer cables and instrumentation for the four hole array had been installed and the recording equipment was in the process of being checked. The first tapes were in Bergen for correlation processing. Some analog processing was also done at the site.

By 1 December the (four hole) SP system was fully checked and in operation. The fifth shallow hole seismometer, surface cable connection hole-DRC, and check-out were complete 13 December. Installation and check-out of the seismometers for the two deep (60 m) holes were finished 18 December.

The LP seismometers were installed and the LP system was in the check-out phase by 1 December. The system was operational the first days of December.

b) Oyer

The installation of the SP seismometers started 8 November and was finished 22 November.

The recording equipment for the SP subarray arrived Oslo on 19 October. Inspection of the shipment disclosed that one of the large crates was partly damaged, evidently from a heavy blow which probably was due to a fall during transport. The contents of the crate, a main rack of the Astrodata system, was also mechanically distorted, but it was impossible to determine its operational state until check-out was performed at the DRC. This showed eventually that the twisting of the structure had only led to a very minor fault in the electronics hardware.

The equipment was transported to Oyer and placed in the hut the following week (43). The final connections and the overall check-out of the system had to wait until power and seismometers had been installed, i.e. the last part of November. The SP system was fully operational by 6 December.

Installations in the LPV started late in November and were completed 9 December. The delivery of the LP recording equipment (Dart) was overdue, thus the LP system was not operational until 4 January 1968.

c) Borgseter

The LP seismometers were installed and the tanks and vault pressure tests passed by 16 December. The delivery of the Dart recorder was much overdue. Installation and check-out of the system were completed 26 January 1968.

### 3.8.2 Calibration and check-out of SP system at Oyer

a) Procedures

The following check-outs were carried out:

- Check-out of the cable pairs between the DRC junction box and the WHV junction box. (The resistance of each pair was measured with the pairs opened and shortened at the field end).
- The resistances to earth of the different seismometer contacts were measured. These are to be in the order of megohms. The resistances to earth of the conductors of the incoming cables were also measured.
- After applying power from the DRC the voltage was adjusted in the DRC for correct value at the WHV.
- The voltage applied to the amplifier and the amplifier balance was checked and adjusted to correct value. (The amplifier gain was adjusted at an earlier stage).
- After having carried out these items successfully a calibration signal was applied from the DRC, and the signal coming back from the WHV was measured.
- The same was done when by-passing the seismometer, actuating a by-pass relay in the WHV.

In order to avoid influence from unchecked parts of the system power, calibration signals and bypass signals were only applied to the WHV under test, and to already checked vaults.

One tried to find out whether all the WHVs were in phase by jumping on the ground near the holes and checking whether the responses were equal with regard to phase. This method was very uncertain, and it was found that the only way to be sure was to wait until a real event was recorded and then compare the signals from the different WHVs.

b) Special problems and experiences

Much time was wasted because 3 seismometers and one signal amplifier had to be changed after their final installation.

It is considered that a simple go-no-go check of equipment before installation is worth while in order to avoid transportation and installation of faulty equipment.

When the field installation was finished a final check-out and calibration of the system was carried out by teams consisting of two engineers in the field and one at the DRC. This arrangement is also suggested for the Phase 2 installation.

3.8.3 Calibration and check-out of the LP-systems

a) Procedures

Calibration of the seismic system comprised two different aspects:

- The determination of sensitivity parameters, amplifier gains, dc offsets, frequency responses, free periods, mass positions, dampings and adjustment of these parameters to standardized values where practicable. This was done during the installation phase of the system for each component, and during re-conditioning of apparatus that had failed or shown anomalies.
- Test signals, interleaved in the normal data acquisition run of the system, were selectively looped through the system. They exercised the whole chain of apparatus from the sensors to the data evaluation centre, or parts of this chain. The purpose was partly to increase the credibility of the data and partly to facilitate maintenance work.

b) Problems and experiences

It is suggested that for Phase 2 a greater amount of prefabrication of cable harnesses be done in the workshop in order to save time at the site during installation and testing.

The time-consuming part of the check-out is the seismometer calibration. This work is done partly in the LPV and partly in the DRC which are located only about 100 m from each other.

Neither transportation nor weather conditions will therefore in this case play any important role for this work. It is estimated that one complete LP-installation check-out done by two engineers will on the average take about 4 - 5 days.

The methods of installations calibration should be reviewed with the purpose of:

- avoiding misleading information being accepted
- improving accuracy
- speeding up testing, particularly in the field
- simplifying test gear, reducing weight
- inclusion of an all-over method that checks that all previously taken data are consistent
- simplifying arithmetic work during testing

The presently used methods are characterized by not using null compensation. It is thought that if the weight lift were performed with a simultaneous break of compensating current, the compensation current could be found more accurately and more quickly.

The horizontal weight lift arrangement used in the LP seismometer is cumbersome and could be improved. A self-levelling optical system might possibly be used for checking the alignment of the strings.

A direct method for establishing the ratio between the calibrator coil and the data coil would be to feed the same signal (step or sinusoidal) with different amplitudes into the data coil and the calibration coil, and establish the ratio when the two currents have no effect on the movement.

When this ratio is established an amplifier may be inserted between data coil and calibration coil, letting the seismometer be the frequency determining element of the oscillator. By changing the amplification and observing the increased decay rate of oscillations the damping should be established.

The advantage of this method in determining damping is that it will be possible to determine the damping at the different dynamic levels. The present method only checks damping at the upper range levels; in fact, at amplitudes that are practically never obtained in reality.

If the present method of releasing the mass from an out-from-zero position is maintained, it is proposed to observe the damped free period  $T_D$  and the undamped free period  $T_0$ , rather than the amplitudes of successive excursions, and determine the relative damping from

$$D = (1 - (T_0/T_D)^2)^{1/2}$$

which will give approximately the same percentage accuracy in the damping factor as the percentage accuracy in determining the time.

The accuracy of the present method is determined by the accuracy of determining the amplitude of the second excursion, which is very small and easily blurred by noise. It is generally accepted that time measurements are more accurate than amplitude measurements, and in addition the first zero amplitude occurs earlier than the second maximum and is thus not contaminated by noise to the same extent.

The mass position indicator of the LP instruments is time-consuming to adjust. It has to be done in darkness since the photo-cells are sensitive to the ambient lighting in the vault. The results are not immediately seen but have to be reported by telephone from the DRC.

As this circuit is not affected by other adjustments it is proposed to adjust it on the work-bench behind a local screen with controlled voltages on the bridge circuit and provide setting possibilities that cover any variations in line voltage drop from the CT11 to the vault. The final checking after installation should then be easy except in particular cases when the lamp slot or photo-cell has been displaced. A simple method of securing the setting that has been obtained on the work-bench should be devised.

#### 4 CONCLUDING REMARKS

The various purposes served by installing a Phase 1 system as a separate and introductory step in the installation of the large array have been implied or explicitly mentioned earlier in this report:

- Installation of the Phase 1 facilities has provided experience which will be of value when decisions are to be made on the organization of land acquisition and siting as well as technical solutions and methods of construction for the larger Phase 2 installation.
- The operation of the Phase 1 system will bring forth data of importance for the layout of the Phase 2 large array. These data will to a certain degree be decisive for the overall geometrical configuration of the array and will undoubtedly also influence its technical appearance in many ways.

- The Oyer subarray will be incorporated in the large array pattern and be part of the long-term operational system.

This report covers the installation proper of the Phase 1 system; thus only the first of the above items is of relevance here. In the following is given a brief summing up of Phase 1 experiences. It will be noticed that the Phase 1 conditions in several respects were atypical or at least not easily commensurable with conditions anticipated for Phase 2.

#### 4.1 Land acquisition problems

The Defence Construction Services of the Norwegian DOD agreed to take care of the land acquisition for the project. Due to the very short time available, it was decided to restrict the choice of sites to ones within common land owned by the State or a community, anticipating that this would facilitate land acquisition.

This assumption held good in State-owned land (Oyer, Borgseter); no formalities were needed beyond simply to notify the proper authorities. This was the case also at Falldalen when permission had first been obtained from the managing board of the community common land.

Since such limitations obviously cannot be set for the subarray pattern of Phase 2, a much longer period and larger effort must be allowed for acquisition of privately owned land. However, common land should be preferred when there is room for choice.

#### 4.2 Siting of vaults and boreholes

A complete evaluation of the quality of the siting of vaults and seismometer holes would have to balance seismic benefits against costs of each vault/hole. This approach is clearly outside the present scope, which is directed towards practical consequences of the siting.

Judged by the relative smoothness of the vault construction and the drilling as such, the siting was as successful as could be expected. Deep layers of overburden presented drilling problems at some places. Rock outcrops or sites with easily determinable and shallow overburden should be preferred. If such a site is not available, the overburden should be thoroughly sounded to avoid the possibility of unsuccessful and expensive drilling/excavation operations.

The siting in the terrain was largely done by one man on foot, a sufficient effort for the rather limited Phase 1 task. The siting job for the Phase 2 array is larger by an order of magnitude and the need for larger teams is obvious. Use of helicopter is highly recommendable, not only to cut down the time required but also to get a better general view of the transport and trenching problems related to each site.

4.3 Problems in connection with construction and technical installations

These problems have been dealt with in detail earlier in the report, see Chapter 3.

The rapid deterioration of working efficiency with onset of winter conditions was an overruling but not unexpected fact. This concerned not only soil removal operations but hampered also the installation and checking of technical equipment.

It is important that time schedules for future installation periods should reflect this unpleasant fact, and that implementation should keep pace with the completion dates stipulated.

APPENDIX 1

REPORTS AND EXCERPTS FROM REPORTS ON SEISMOLOGY AND GEOLOGY

A1.1 Excerpts from a note dated 25 July 1967 from R Lerner and R Lacos, LL consultants on noise coherency and SP subarrays seismometer spacing

A 4 km spacing was originally chosen for the first Norway small array on the basis of Montana Coherency vs Distance Data. Typically, the coherency is changing slowly through 0.5 at 4 km range and  $f = 0.6$  cps; and, at 1 cps, the coherency is changing slowly through 0.4 at this range. Further data from Montana showed no difference in coherency between seismometers on the surface and those placed in deep holes.

Data from Lillehammer<sup>++</sup> so far indicate a different dependence of coherency on distance. The conclusions would seem to be that coherencies of less than 0.4 can be obtained at distances over 2 km and for frequencies of 0.6 Hz and up. Preliminary further data from Lillehammer taken on a very noisy day is not inconsistent with the above conclusions.

Perhaps Lillehammer is atypical, and perhaps coherency depends differently with depth at Lillehammer as compared with Montana. Further work with Lillehammer data is in progress. But until further experience shows otherwise, it seems that a 3 to 4 km spacing will be conservative in Norway, instead of 4 km being marginal as was originally thought.

On this basis, it appears to us that any array layout which contains about 20 instruments spaced in a convenient pattern 3 - 4 km apart will constitute a satisfactory small array for the noise study. Anticipating that the coherency may be in fact low enough to permit closer spacing in later subarrays, we urge that several of the instruments be placed at 2 km or 1 km spacing.

++ The Ringsaker array

A1.2 Excerpts from report by Mr John C Harlan, President of Drilled Shafts Inc, LL consultant on geology and drilling

At the request of Major D D Young, AFOSR and Mr William Best, SRPG, a visit was made to Oslo, Norway, to determine the capabilities of local water well drillers to drill approximately 20 holes some 160 mm in diameter and 60 meters in depth for a seismic array near Øyer, Norway.

.....

Personal interviews were made with the two larger water well drilling contractors and an on-site inspection was made in the proposed area of installation of the main array.

#### Geology

The area is located north of Lillehammer near the small town of Øyer, Norway, on a plateau some 1000 meters above sea level. The area has been subjected to a north to south movement glacier.

Outcrops of metamorphic rocks of Eocambrian age were observed. These rocks are generally sparagmite with areas of quartzitic sandstone, feldspars and isolated exposures of slate.

The area contains several shallow lakes while a considerable portion of the area is covered with marshland and peat bogs.

Glacial gravel was observed at the surface over the entire area, apparently varying in thickness from one to three meters. Large blocks were observed near the mountain peaks but not over the general area in large numbers as would normally be expected from glacial erosion. Peat moss covers the entire area and varies in thickness from three inches to as much as one foot. It appears that solid bedrock will be encountered at depths less than 20 feet if the locations are kept away from the lakes or peat bogs.

#### Drilling contractors

1) Selvik - This is apparently the largest of the drilling contractors in Norway having been organized in 1950. Approximately 400 wells are drilled per year with 5000 meters being drilled in Norway and 8000 meters being drilled in Sweden. We were advised that three rigs could be made available for this project.

The drilling units are small drills mounted on three wheels and transported as a trailer. One man normally operates the rig. The unit is apparently designed as a mining or blast hole rig and is manufactured by a Belgian corporation and designated



as the HS-5. The downhole hammer is also Belgian made, while the bits being used were manufactured in Sweden.

.....

We were also shown his office, warehouse, and storage yard where he had in stock some 700 feet of 125 mm diameter drill pipe which could be divided among the three rigs available for drilling the 160 to 175 mm holes.

.....

#### Casing and hole diameters

A standard casing of 131 mm (5.15 in.) inside diameter and 140 mm (5.50 in.) outside diameter is immediately available for use in the holes. Since the geophones that are planned to be used are 4.75 in OD, it is felt that this is the minimum diameter casing which could be safely used and still assure clearance for installation and removal of geophones.

If the depth of the holes is not greater than 30 to 40 meters, it is felt that a 160 mm standard bit would be adequate to give the required clearance for easy installation of the casing. However, should the depth requirements be greater than 40 to 50 meters it is felt that the hole diameters should be increased to 175 mm. It should be noted that 175 mm bits are larger than normally used and will require 30 to 60 days delivery time.

Considerations may be given to installation of the holes without casing other than the top two or three meters of unconsolidated material. It is felt that the rock below the surface casing would remain open with no caving occurring. This would greatly simplify the installation of the holes and certainly reduce the cost and construction time involved. It should be pointed out that the water table without a continuous casing would generally be five to fifteen feet below the ground surface.

#### Conclusions

- 1) It is felt that the drilling program as laid out is very little different from that the water well contractors have normally been using and they will experience little or no great difficulty in drilling the holes in the extremely hard formations.
- 2) Since the contractors normally only set a few feet of casing in their water wells, they were reluctant to estimate just what difficulties would be encountered in setting the casing. Therefore, it may be necessary to furnish portable electric welding machines, welders and possibly portable derricks to install the casing since it cannot be done with the drilling rigs.
- 3) It will apparently take one rig two weeks to drill a 160 mm hole 60 meters deep and set the casing (based on six shifts per week of eight hours each).
- 4) The recent contour map of the area (Sheet 1817-I) was found to be quite accurate in detail and may possibly be used in locating the actual locations of each station without a survey.

#### Recommendations

- 1) Negotiate separate contracts immediately with each of the two contractors to furnish all necessary drilling equipment, labor, tools, bits, transportation, etc,

to drill approximately half of the job with the understanding that either contractor could finish work not completed by the other. Negotiations should be on a footage basis but both contractors appear to be reputable enough that an hourly basis could be just as advantageous.

- 2) Schedule the noise level holes that are to be drilled north-east of Oslo first and start on them as soon as possible. Geologic maps and reports along with surface geology indicate that this will be a more difficult area than the Øyer area.
- 3) Determine as soon as possible the amount of casing to be cemented in order to plan the cementing procedures.
- 4) Determine if it is possible to set the geophones under water in an open hole.

A1.3 Excerpts from report dated 8 Sep 1967 by Norconsult geologist on survey and siting of boreholes for Øyer SP subarray (original in Norwegian, translation not official)

Attendants at survey: Mr Ronning, Philco-Ford  
" Christensen " "  
" Hatle, Norconsult A/S

Map reference: Gopollen 1817 I, 1967, Grid zone 32V  
Air photo ref: Øyer, series 3013, 1967, scale 1:15000

The boreholes are marked by wooden poles of length 2 m, numbered from 1 to 20.

Borehole 1            Map ref NP 849-015  
                         Photo " E15

Borehole 1 is situated approx 100 m N of the road between Brettdalen and Akksjøseter, on a mountain terrace running E-W. Bedrock is exposed several places and the area is treeless. Depressions in the terrain are sparsely covered with morainic material with heather-humus on top.

The upper layers of the bedrock consist of dark sparagmite with strike E-W and dip 30° N. Lower layers near the road contain a dark shale with strike and dip as above. The shale is less permeable than the sparagmite, and the ground water emerges along the strike direction at road level as shallow ponds which are drained towards W.

It is assumed that the ground water level at the borehole corresponds to the level of the ponds i.e. 6 - 7 meters below the borehole surface.

The firm ground and slightly hilly terrain should present no transport problems.

#### LP vault

Site for the LP vault was marked approx 50 m N of borehole 1. The site is on a slope of loose deposits with rock outcrops visible at the top of the slope. Bedrock foundation and easy drainage are both enabled by making a cut in the hillside adjusted to the vertical dimensions of the structure.

#### CT vault

A site for the CT vault was marked some 25 m W of borehole 1, also on a small slope with rock outcrops at the top. The above considerations regarding foundation and drainage apply also here.

#### Site for temporary recording house

A site for the house was staked on a small morainic ridge about half-way between borehole 1 and the road. The site is well drained in all directions and the depth to bedrock is probably small.

#### Water supply

Water for the house can probably be supplied from a pond some 150 m from the site. The difference in altitude is about 3 m.

It should be mentioned that an existing water supply for the mountain farms further downhill is by means of a plastic hose running from a well above the road (NW) and down to the road-fork near the house site. This should be kept in mind when digging cable trenches in the area.

#### Sewer

The sewer may conveniently be led under the road and down the hillside below.

Borehole 2A            Map ref NP 876-029  
                          Photo " D17

The borehole is staked W of and approx 150 m from the river Ner-Åsta. There are outcrops of rock which have been worn by the river into flat benches. The bedrock consists of light and dark sparagmite with some thin layers of dark shale. The strike is E-W with dip  $10^{\circ}$  to the north. There is a secondary cracking NNE, with steep dip.

Due to noise from the River Ner-Åsta and difficult transport conditions it was decided to look for another site for this seismic point.

Borehole 2B            Map ref NP 874-026  
                          Photo " D17

Borehole 2B is staked close to the trail from Akksjøseter, approx 400 m closer to the house at the descent to the valley by borehole 2A.

It is situated in an open field covered by grass and surrounded by small trees. Outcrops of rock cannot be traced in the vicinity, but loose boulders consist of dark sparagmite. Depth to bedrock is estimated to 10 m. A strip of bog running SE from the site down to the valley might facilitate digging of ditches

Transportation of the drill rig from Akksjøseter to the site will be difficult as the trail is rough and stony, but is feasible with powerful tractors.

It is recommended that borehole 2B be used because of more favourable transport and seismic noise conditions. Seismic soundings should be performed to find the optimum drilling point, i.e. the point having the least depth of overburden.

Borehole 3                    Map ref NP 919-036  
                                 Photo " D20

Borehole 3 is staked on a long mountain ridge running NNW. Outcrops of rock cannot be observed at the surface as the ridge is covered by morainic drifts consisting of gravel and flat boulders with a thin layer of heather humus. The terrain is diverse with scattered trees and open spaces.

The borehole is staked approx 10 m E of the trail from Bøsætra. Nearby there is a depression in the terrain approx 6-7 m deep which is most probably a sunken moraine. Approx 100 m E of the site and 10-12 m lower down there is a bog. The borehole was not staked in the depression itself because of the possibility of flooding. Depth to groundwater level will be about 10-12 m.

Transport conditions are good, the existing path from Bøsætra being firm and free from large boulders.

It is recommended that the depth of the overburden be checked by means of seismic soundings in order to find the best site for the borehole.

Borehole 4                    Map ref NP 876-066  
                                 Photo " C17

The map-derived site for borehole 4 turned out to be in the middle of a bog, and was immediately rejected due to impossible transport conditions and non-existence of rock outcrops.

The new site for borehole 4 is about 600 m closer to point 5, i.e. at the S-E end of Skyttilhaugen. The area has some forest and marshy tracts.

There are some outcrops and the rock is a dark sparagmite with numerous quartzitic veins oriented independent of the stratification. The strike of the rock is E-W and dip about 60° N. The rock forms horizontal benches and there are secondary cracks in NS and NW direction with steep dip.

About 7 m further south and 1 m lower, there is a marshy tract which indicates the ground water level in this area.

Transport conditions are very poor. Only a very primitive track leads to the site and this track has obstacles in the form of large boulders, passes through swampy bogs and crosses creeks on rudimentary bridges.

It is recommended that helicopters be used for transport of drill rigs to borehole 4.

Borehole 5                    Map ref NP 853-056  
                                 Photo " C15

Borehole 5 was staked on a small rock terrace about 100 m N of the cross-roads at Djupslia.

At the request of Mr Brown, LL, borehole 5 was moved about 500 m W along the road passing Djupslia. This was done in order to maintain a distance of 3 km between boreholes 4 and 5.

Borehole 5                      Map ref NP 848-058  
(corrected)                      Photo " C15

Borehole 5 is staked on a mountain terrace running E-W about 100 m N of the road passing Djupslia.

The area has rock outcrops, sparsely covered with quarternary deposits and forest and heather on the surface.

The rock consists of slaty, dark sparagmite with some sulphide minerals. The strike is EW, and dip about  $70^{\circ}$  N. Ground water level is probably below the bottom of a 15 m borehole.

Access is from a nearby road up a gentle slope in slightly hilly terrain and transport conditions are quite good.

Borehole 6                      Map ref NP 856-089  
    Photo " B16

Borehole 6 is staked at the top of a small mountain ridge about 200 m W of the chalet Tautra.

The site has rock outcrops with some quarternary deposits in the depressions of the terrain, and there are no trees.

The rock is sparagmite with some separate quartzitic veins. The strike is E-W and dip  $80^{\circ}$  N. Secondary cracks have strike NS with steep dip. There is also horizontal cracking in benches with dip about  $10^{\circ}$  S. The rock is cracked in a great cubic pattern, giving a massif appearance.

From the top of the mountain ridge to a small bog on the NW side, the difference in altitude is about 10 m. The ground water will probably be at this level in the borehole.

Access is via the chalet Tautra, along an undulating and winding track with steep inclines. Transport conditions are very difficult and it necessary to use very powerful tractors to force these steep slopes.

It is recommended that helicopter transportation to borehole 6 be considered.

Borehole 7                      Map ref NP 817-088  
    Photo " B12

Borehole 7 is staked near the top of a mountain ridge, about 400 m E of the chalet Flåtåmoslæen.

The site has outcrops of rock with some quarternary deposits in depressions in the terrain, and there are no trees.

The rock is dark sparagmite with numerous quartzitic veins and some pyrite. The strike is E-W and dip  $45^{\circ}$  N.

Ground water level is deep because the mountain ridge is drained in several directions and there is no reason to anticipate difficulties on this account.

Transport conditions are good. There is easy access from the road south of the borehole in slightly hilly terrain.

It is recommended that ground water in the borehole be tested for corrosivity against concrete and steel.

Borehole 8                    Map ref NP 825-033  
                                  Photo " D13

Borehole 8 is marked about 100 m on the W side of the road passing Nysetra, and about 1200 m NE of this chalet.

This site is on a typical till where the deposits consist of gravel and heather bog. The area has only a few trees with some heather humus around the bog areas. About 100 m W of the borehole and about 2 m lower down, there is a swampy bog. Groundwater level will probably be high in this hole.

Transport conditions to the borehole are very good, over a firm, even moraine.

It is recommended that seismic soundings be made in the area in order to find the best site for the borehole.

Borehole 9                    Map ref NP 788-064  
                                  Photo " C9

Borehole 9 is staked about 3 m W of the end of a minor road, S of Vargøymyra.

The site consists of dense brushwood of birch. The quarternary deposits consist of gravel and great boulders. Bedrock is to be found about 30 m S of this site on private property, G nr 90, b nr 2, belonging to Ola Kråbøl, Øyer.

The rock is light and dark sparagmite with some thin layers of dark shale. The strike is E-W and dip about 65° N.

Groundwater can be seen at the surface as a spring about 4 m lower than the borehole. It is therefore probable that the ground water will be high in the hole.

Depth to bedrock is probably small because there is exposed rock close by.

Transport conditions are good and it is possible to drive by car to the drilling site.

It is recommended that the ground water be tested for corrosivity.

Borehole 10                    Map ref NP 765-015  
                                  Photo " E8

Borehole 10 is staked about 100 m S of the chalet Sydda on a gentle incline.

The site has rock outcrops at several places and is covered by a thin layer of gravel and turf. There are no trees in the area.

The rock is a very slaty, dark sparagmite shale, with grains of pyrite and chalcopryrite. Strike is E-W and dip 40° N.

About 40 m below the borehole, there is a spring and well. The difference in altitude from the well to the top of the borehole is about 6 m. Ground water is therefore expected to be high in the borehole.

Transport conditions are good. It is possible to drive by car to the drilling site.

It is recommended that the ground water be tested for corrosivity.

Borehole 11            Map ref NP 813-998  
                         Photo " B12

Borehole 11 is marked off about 700 m E of Storhaugen on a rising at the S end of a bog.

The site has rock outcrops and is covered by a thin layer of gravel. There is heather humus in depressions in the terrain, and there are no trees in the area.

The rock is dark sparagmite with quartzitic veins. Strike is E-W and dip  $75^{\circ}$  N. There are secondary crackings with strike NS and steep dip, and horizontal cracking. The rock thus has the appearance of blocks.

Difference in altitude to the nearby bog is about 10 m. Ground water is therefore expected in the lower parts of the borehole.

Transport conditions are difficult because there is neither road nor track to the site. The most appropriate access route will be on the W and S side of the bog along Storhaugen. The ground here is firm but hilly.

Borehole 12            Map ref NP 782-985  
                         Photo " F7

Borehole 12 is sited on a small elevation in the terrain about 500 m NE of Steinsetra.

The site has no outcrops and the ground consists of moraine with gravel and large boulders. It is difficult to ascertain the depth to bedrock because there are no outcrops in the vicinity, but it is probably great since the mountain here inclines gently down to Gudbrandsdalen and great morainic deposits have been pushed in this direction.

There are boggy areas to the N and E, the difference in altitude from the top of the borehole being about 5 m. Ground water is expected to be high in the borehole.

Transport conditions from the road to the borehole are good. The distance is about 100 m in gentle, hilly terrain.

It is recommended that seismic soundings be performed before drilling begins.

Borehole 13            Map ref NP 808-963  
                         Photo " G9

Borehole 13 is staked at the S end of Stormyra, about 100 m from the road.

The site has no outcrops and the soil consists of moraine with sand, gravel and large stones. The moraine has dammed up Stormyra bog on the S side, and it is therefore likely that the moraine has low permeability. The difference in altitude from top of borehole to the bog is about 2 m, and it is probable that there will be ground water in the hole. The area has some scattered brushwood and heather humus in the higher parts.

With regard to quarternary deposits, the same conditions apply as for borehole 12, i e probably great depth to bedrock.

Transport conditions to the borehole are good, in gentle hilly, but firm terrain.

It is recommended that seismic soundings be performed before drilling commences.

Borehole 14            Map ref NP 843-974  
                         Photo " F12

Borehole 14 is staked on a long mountain ridge about 200 m E of the road passing Høgåsen. The site has exposed rock with some soil in depressions in the terrain. The rock consists of a hard, dark sparagmite with some biotite and pyrite. Strike is NW and dip  $70^{\circ}$  N. Secondary cracking runs NE with a steep dip.

The mountain ridge forms a natural dam for a bog on the N side with a marshy tract between the borehole and the road, down to a lower level in the S. The area has some widely scattered brushwood with peat and heather humus on the surface.

The ground water level is indicated by two dams NE of the borehole with a difference in altitude of about 2 m. The rock is however very massif, so there will not necessarily be ground water in the borehole.

Transport conditions are good except for the above-mentioned 20 m wide marshy tract.

It is recommended that the ground water be tested for corrosivity.

Borehole 15            Map ref NP 844-936  
                         Photo " H13

Borehole 15 is staked about 400 m on the N side of the road passing Veslesetra. The site is on a flat moraine mound with soil consisting of gravel and scattered boulders. The area has only a few scattered bushes and heather humus on the surface.

Depth to bedrock is uncertain because there are no outcrops in the immediate vicinity.

On the W side of the borehole there is a bog, the difference in altitude being about 15 m. Ground water is expected to be at this level, maybe somewhat higher.

Transport conditions are fairly good. Access is along an undulating trail and it is necessary to use a tractor.

It is recommended that seismic soundings be performed before drilling borehole 15.

Borehole 16            Map ref NP 873-941  
                         Photo " H11

Borehole 16 is staked about 150 m N of Sjøsetra in terraced terrain, the mountain ridges running E-W. There are no trees on the site. The surface is covered by heather humus and grass turf.

Outcrops can be seen at several places and the rock is dark sparagmite with some scattered grains of pyrite. Strike is E-W and dip  $70^{\circ}$  N. Secondary cracking is N-S with steep dip. There is also horizontal cracking, forming terraces.

At the borehole there is about 2 m of morainic drift.

In the same area there are several springs which emerge near the borehole. The ground water will undoubtedly be high in the borehole.



Access is from a nearby road and transport conditions are good. The terrain is mostly meadow with some scattered stones.

It is recommended that the water be tested for corrosivity.

Borehole 17            Map ref NP 875-984  
                         Photo " F15

Borehole 17 is staked about 200 m N of the chalet Brennlia on a long mountain ridge running E-W.

There are no trees and the surface is covered by a thin layer of morainic drift with heather humus on top. Depth of the moraine is estimated to be 1 m. E of the point there is exposed rock, a light sparagmite with quartzitic veins. Strike is E-W and dip  $60^{\circ}$  N. Secondary crackings run NW with steep dip, and horizontally forming terraces.

The site is drained in several directions, and it is assumed that the borehole will be dry. Water for the drilling may be problematic.

Transport conditions are very good since a car can be used to the borehole.

Borehole 18            Map ref NP 914-968  
                         Photo " G(F)20

Borehole 18 is staked about 40 m S of the road passing Brennhaug on a steep hill facing south, by the river Gjæsa.

The terrain consists of talus masses from the mountain above and quarternary morainic deposits with gravel and great boulders. The site is on the E side of a clearing where the rock is exposed at the edge of the woods. South of the point there is an E-W dislocation where the depth to bedrock may be great owing to the talus masses. A borehole at a point where bedrock is sure to be reached was preferred, even though the distance to the road above is short.

The rock is light sparagmite with strike E-W and dip  $80^{\circ}$  south. Secondary cracking is N-S and dip  $60^{\circ}$  W.

A few meters W of the point there is a spring, but on account of the intense cracking towards the valley, it is assumed that the hole will be nearly dry.

Transport conditions are fairly good, along an old steep trail.

Borehole 20            Map ref NP 841-011  
                         Photo " E14

Borehole 20 is marked off about 100 m E of the road through Brettdalen, located on a hill facing south.

There are no trees in the area and the ground consists of moraine with grass peat and heather humus on the surface.

Rock outcrop was not observed in the vicinity, but in the hills above Brettdal there are some E-W mountain ridges that have outcrops.

The depth of the soil is uncertain, but is assumed not to be too deep. About 100 m S of the point there was observed a side moraine and an esker.

Depth to ground water is assumed to be about 10 m, corresponding to the difference in altitude between the borehole and a nearby bog.

Transport conditions are good. It is possible to drive to the borehole by car.

It is recommended that seismic soundings be performed around borehole 20 in order to try to find a better site.

A1.4 Report dated 8 March 1968 from Norconsult A/S on seismic soundings at Oyer during the period 6 - 16 September 1967

Introduction

Norconsult A/S has been assigned by the NDRE, Kjeller, to evaluate the subsurface conditions in connection with the drilling of seismometer holes for the seismic station at Oyer, Lillehammer. As part of this work, seismic soundings of the loose deposits have been carried out at 8 different areas within the project site during the period of September 6-16, 1967. The purpose of the soundings has been to find the locations where the depth to bedrock is most shallow in order to reduce, or possibly eliminate drillings in the loose deposits. Where the depth to bedrock is less than 4 m, one counts on being able to replace the drillings with excavation to bedrock.

Program of measurements

The program of measurements comprises 8 different areas of measurement placed with 3 - 5 km in between. The layout is shown in Figure A1.1. In the terrain the areas are marked by baseplugs numbered Hole 2B, 3, 8, 12, 13, 15, 19 and 20.

Within each area two 105 m long profiles were measured with intersection above the primary selected point of drilling. The location of the profiles has otherwise been determined by proximity to roads, and peat bogs have been avoided as far as possible.

A plan of the profiles within the different areas is shown in Figure A1.2.

Measuring equipment, personnel, extent of measurements

The extent of the technical investigations is shown in the table below which gives time spent, measuring equipment, personnel, material used etc:

Period of measurements:	September 6 - 16, 1967
Personnel:	Ing Sundin and Ing Wedberg, A/S Seismiske Målinger and 3 assistants
Profiling:	Ing Kristiansen, Norconsult A/S
Method of investigation:	Seismic refraction
Apparatus applied:	Semab, 22 channels
Elevation basis:	Local elevation system in meters
Element of investigation:	Land

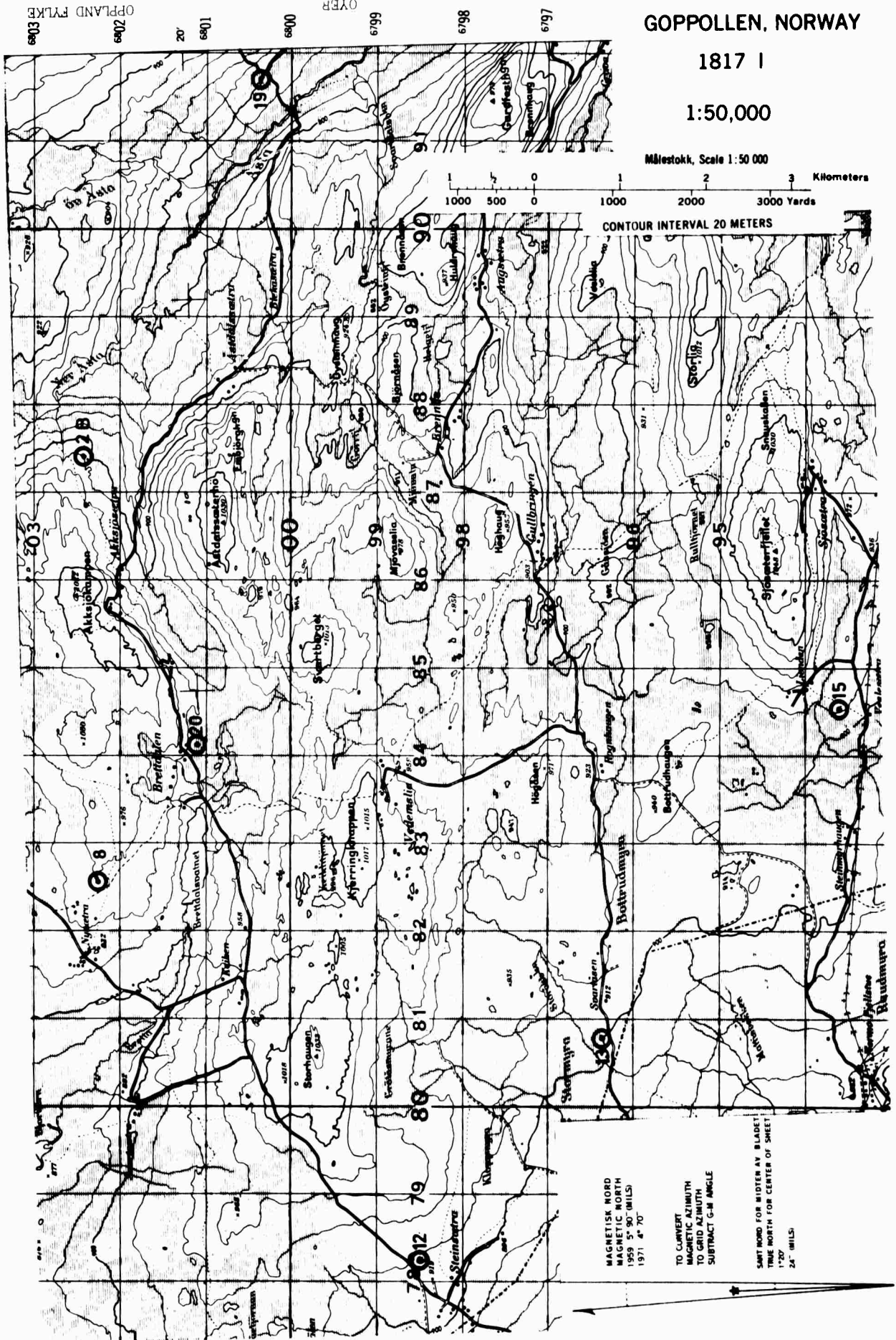

Figure A1.1 Sites where depth of overburden has been determined by seismic soundings

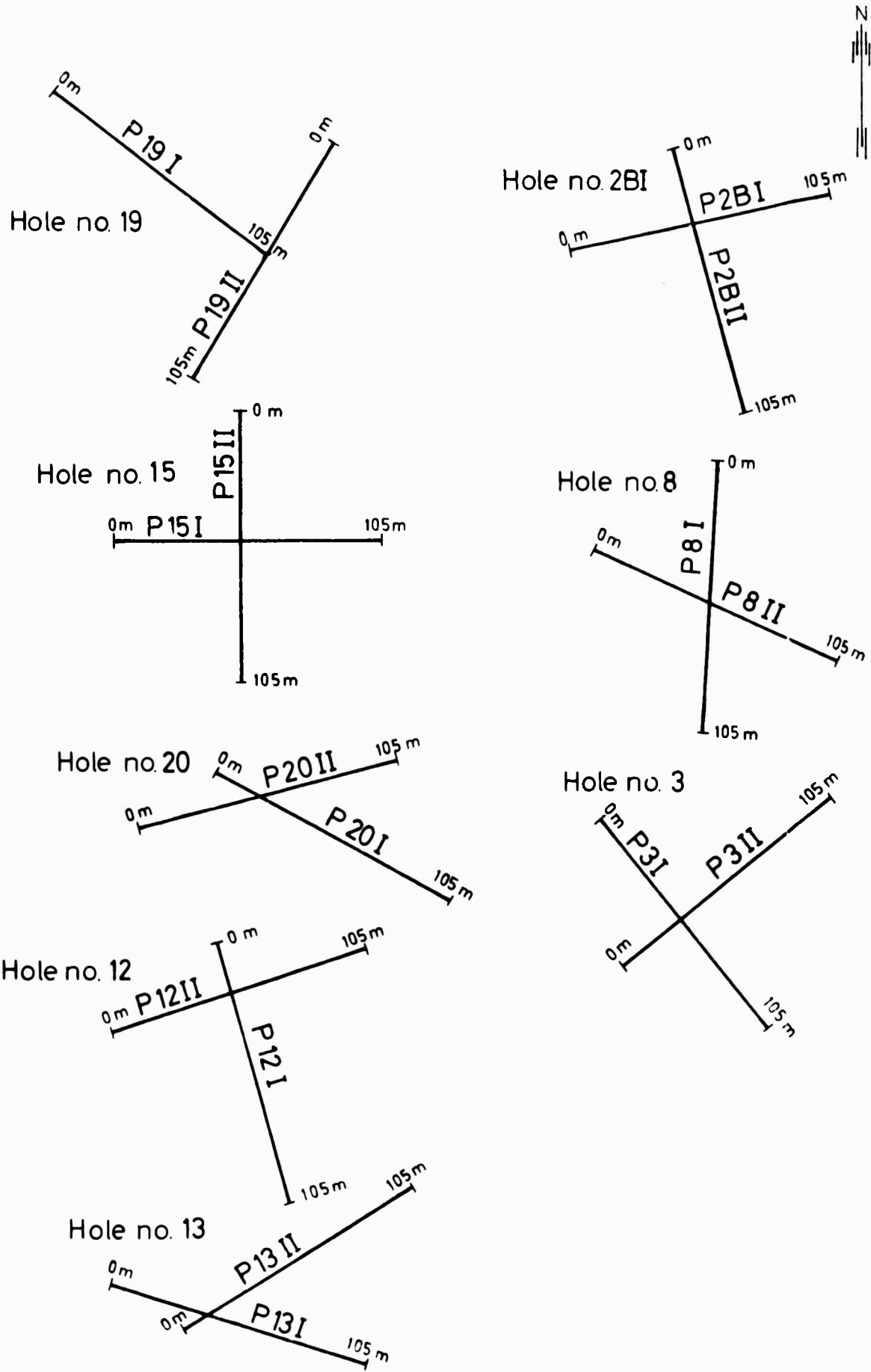

Figure A1.2 Orientation of seismic sounding profiles

Loose deposits:	Moraine
Local transportation:	Cars and tractors
Preliminary result:	Results given continuously
Time spent:	9 days
Journeys and preparations:	2 days
Field work:	7 days
Material used:	7.4 kg dynamite and 120 percussion caps
Number of profiles:	16
Total length of profiles:	1600 meters
Length of profiles with velocity measurements:	1600 meters
Number of initiation points:	80
Number of soundings	352
Median depth of loose deposits:	6.4 meters
Total depth measurement:	2609 meters

Results of measurements

The results of the measurements are given below:

<u>Profile No</u>	<u>Distance along the profile (meters)</u>	<u>Depth (meters)</u>	<u>Remarks</u>
Hole 2B I	2.5	6.0	Local elevation system
	27.5	3.5	
	52.5	4.5	
	77.7	5.0	
Hole 2B I	102.5	5.6	
Hole 2B II	2.5	4.1	I = 50/II = 30
	27.5	4.5	
	52.5	2.3	
	77.5	2.5	
	102.5	3.8	N - S
Hole 3 I	2.5	7.3	NW - SE
	27.5	6.9	
	52.5	4.6	
	77.5	5.2	
	102.5	6.2	
Hole 3 II	2.5	5.3	I = 50/II = 30
	27.5	4.1	
	52.5	7.0	
	77.5	8.5	
	102.5	6.9	SW - NE
Hole 8 I	2.5	4.5	N - S
	27.5	3.7	
	52.5	4.2	
	77.5	4.3	
	102.5	4.3	
Hole 8 II	2.5	4.1	I = 55/II = 50
	27.5	3.3	
	52.5	4.4	
	77.5	4.7	
	102.5	5.2	NW - SE
Hole 12 I	2.5	4.5	N - S
	27.5	4.5	
	52.5	5.5	
	77.5	2.8	
	102.5	2.5	

Profile No	Distance along the profile (meters)	Depth (meters)	Remarks
Hole 12 II	2.5	5.2	I = 20/II = 50
	27.5	4.6	
	52.5	4.7	W - E
	77.5	4.3	
	102.5	4.1	
Hole 13 I	2.5	3.1	NW - SE
	27.5	3.1	
	52.5	5.8	
	77.5	4.9	
	102.5	5.3	
Hole 13 II	2.5	4.0	I = 40/II = 10
	27.5	4.3	
	52.5	5.0	SW - NE
	77.5	5.0	
	102.5	4.8	
Hole 15 I	2.5	9.2	W - E
	27.5	10.2	
	52.5	7.7	
	77.5	8.1	
	102.5	7.7	
Hole 15 II	2.5	11.1	I = 50/II = 50
	27.5	11.0	
	52.5	8.3	N - S
	77.5	7.3	
	102.5	8.6	
Hole 19 I	2.5	9.0	NW - SE
	27.5	8.2	
	52.5	4.7	
	77.5	1.5	
	102.5	1.9	
Hole 19 II	2.5	9.0	I = 105/II = 50
	27.5	7.7	
	52.5	2.5	SW - NE
	77.5	4.1	
	102.5	3.3	
Hole 20 I	2.5	11.1	SW - NE
	27.5	9.6	
	52.5	8.3	
	77.5	8.7	
	102.5	9.8	
Hole 20 II	2.5	9.5	I = 20/II = 50
	27.5	8.4	
	52.5	10.7	NW - SE
	77.5	12.9	
	102.5	12.6	

The results of the soundings and profiles carried out that indicate the estimated depth to bedrock are shown as 16 profiles in Figures A1.3 and A1.4.

#### Conclusions

Most of the seismic sounding points indicate a shallow depth to bedrock. It has been possible to place the points such that only two drill holes (20 and 15) would have to penetrate more than 4 m of loose deposits.

The most shallow depth to bedrock within each area of measurement is obtained by placing the drillholes at the following locations:

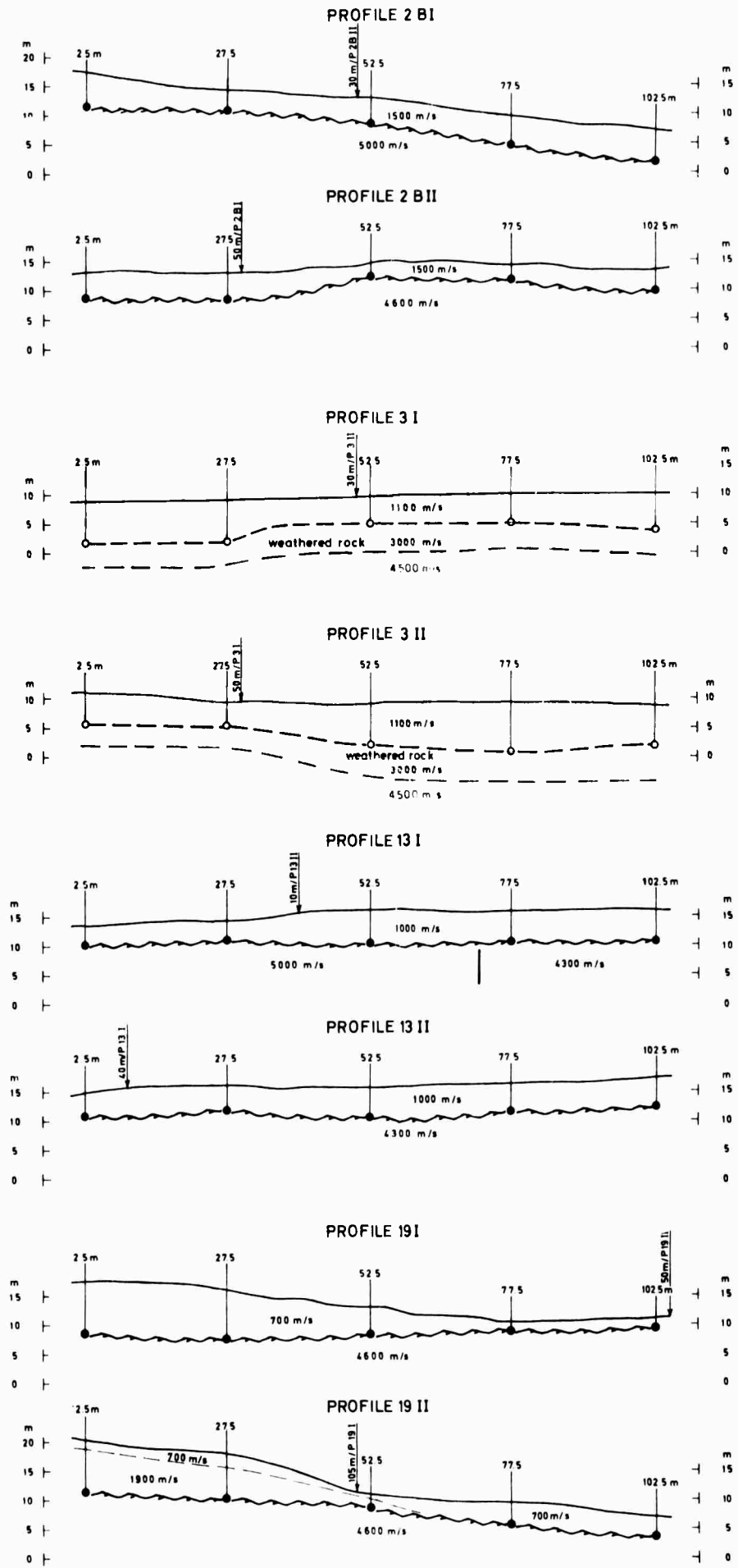

Figure A1.3 Measured profiles

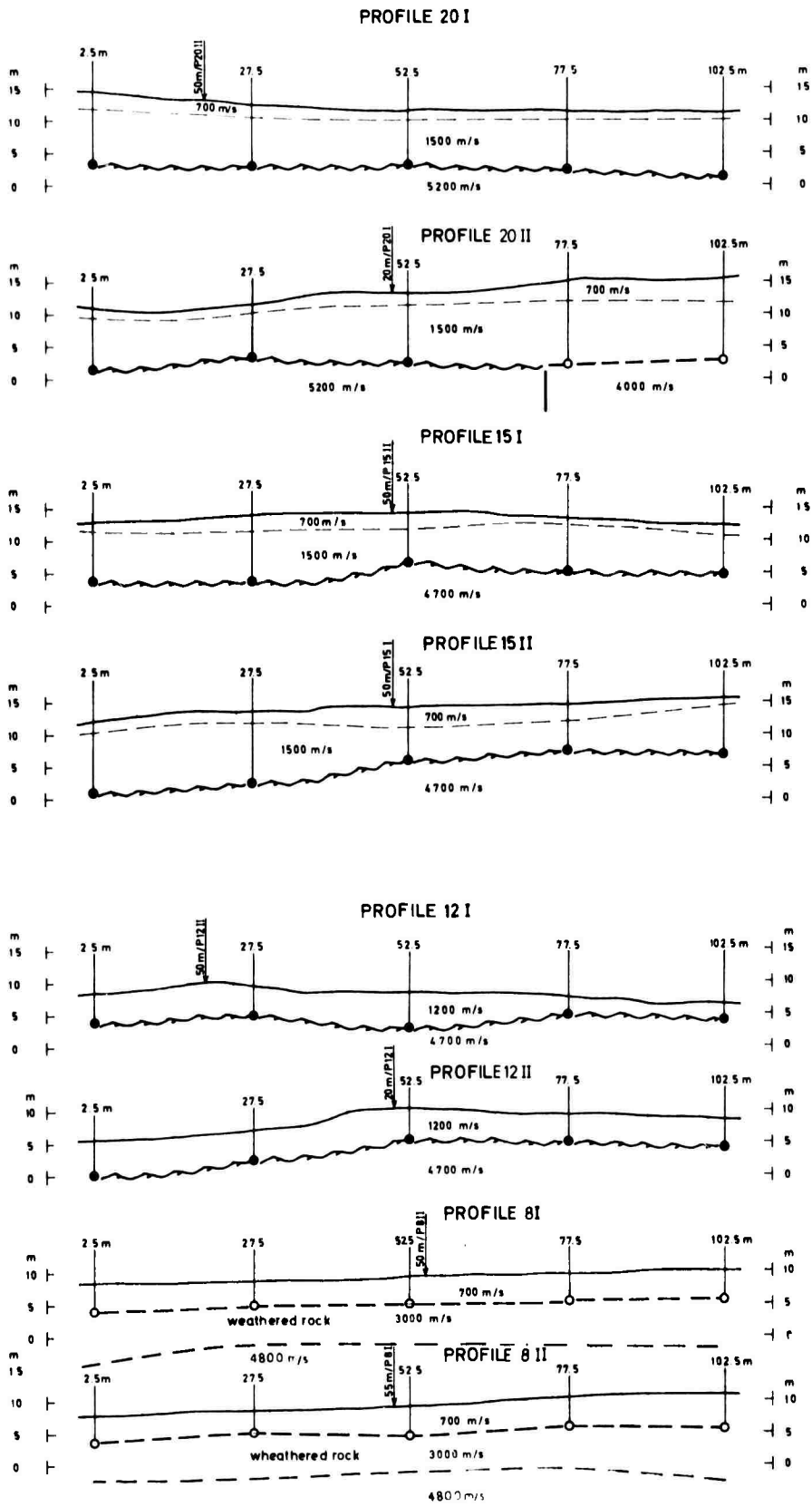

Figure A1.4 Measured profiles



Hole No	Least depth of loose deposit (meters)	Position
2B	2.3	27 m S of baseplug
3	4.1	2 " SW " "
8	3.3	23 " NW " "
12	2.5	82 " S " "
13	3.1	13 " NW " "
15	7.3	27 " S " "
19	1.5	25 " NW " "
20	8.3	32 " SE " "

A1.5 Coordinates of seismic points, NORSAR Phase 1

Seismic point	Sta-tus	Cartesian		UTM - system		Altitude in meters above sea level
		<sup>o</sup> N	<sup>o</sup> E	X	Y	
1OY (1)		61 <sup>o</sup> 20'13.4546"	10 <sup>o</sup> 35' 8.2385"	6801524.999	584847.858	974.54
1A1 (8)		61 <sup>o</sup> 21'17.2450"	10 <sup>o</sup> 32'36.2904"	6803444.364	582542.923	922.22
1A2 (9)		61 <sup>o</sup> 22'59.9818"	10 <sup>o</sup> 28'25.5383"	6806536.715	578746.490	904.95
1A3 (7)		61 <sup>o</sup> 24'13.9576"	10 <sup>o</sup> 31'50.6081"	6808895.390	581736.124	1004.63
1B1 (5)	nu					
1B2 (6)	nu	61 <sup>o</sup> 24'12.8450"	10 <sup>o</sup> 36'14.4468"	6808954.975	585649.818	1024.79
1B3 (4)	nu	61 <sup>o</sup> 22'57.8984"	10 <sup>o</sup> 38'22.9222"	6806683.760	587613.428	970.82
1C1 (2)		61 <sup>o</sup> 20'46.2759"	10 <sup>o</sup> 38' 4.0405"	6802604.810	587435.264	918.80
1C2 (3)		61 <sup>o</sup> 21'12.9977"	10 <sup>o</sup> 43' 4.9589"	6803546.275	591884.295	961.67
1C3 (19)		61 <sup>o</sup> 19'29.9726"	10 <sup>o</sup> 42'49.3073"	6800353.020	591735.483	799.45
1D1 (17)		61 <sup>o</sup> 18'32.0614"	10 <sup>o</sup> 38' 0.6381"	6798451.451	587488.536	931.81
1D2 (18)		61 <sup>o</sup> 17'38.2190"	10 <sup>o</sup> 42'20.3333"	6796884.583	591395.026	864.40
1D3 (16)		61 <sup>o</sup> 16' 9.3848"	10 <sup>o</sup> 37'45.4451"	6794031.946	587372.649	990.42
1E1 (14)	nu	61 <sup>o</sup> 18' 0.8621"	10 <sup>o</sup> 34'18.8549"	6797405.276	584212.669	929.51
1E2 (15)	nu					
1E3 (13)	nu					
1F1 (11)		61 <sup>o</sup> 19'24.1201"	10 <sup>o</sup> 31' 5.7732"	6799913.060	581279.788	989.98
1F2 (12)	nu					
1F3 (10)	nu					
1F4 (20)		61 <sup>o</sup> 20' 2.2700"	10 <sup>o</sup> 34'17.3629"	6801160.699	584100.071	928.35

Table A1.1 Oyer subarray coordinates  
(nu = not in use, incomplete hole or seismometer not installed, ref Figure 2.13).

Seismic point	Cartesian		UTM - system		Altitude in meters above sea level
	$^{\circ}$ N	$^{\circ}$ E	X	Y	
SH 1	60 $^{\circ}$ 38'18,1616"	11 $^{\circ}$ 28'13,3811"	6725207,163	635114,040	361,79
DH1	60 $^{\circ}$ 38'18,2460"	11 $^{\circ}$ 28'13,1265"			
SH 2	60 $^{\circ}$ 36'48,7306"	11 $^{\circ}$ 28'38,2305"	6722455,743	635595,715	329,92
DH 2	60 $^{\circ}$ 36'48,7338"	11 $^{\circ}$ 28'38,6270"	6722456,071	635601,738	330,15
SH 3	60 $^{\circ}$ 36'14,2174"	11 $^{\circ}$ 29'13,0297"	6721408,416	636165,031	374,50
SH 4	60 $^{\circ}$ 36'12,7661"	11 $^{\circ}$ 27'25,3085"	6721301,932	634528,920	301,74
SH 5	60 $^{\circ}$ 36'47,6803"	11 $^{\circ}$ 30'24,5923"			

Table A1.2 Falldalen SP noise study array coordinates  
(SH = shallow hole, DH = deep (60 m) hole)

Seismic point	Cartesian		UTM - system		Altitude in meters above sea level
	$^{\circ}$ N	$^{\circ}$ E	X	Y	
Øyer LPV	61 $^{\circ}$ 20'14,8863"	10 $^{\circ}$ 35' 7,5135"	6801569,030	584836,008	978,43
Falldalen LPV	60 $^{\circ}$ 36'23,0274"	11 $^{\circ}$ 28'50,9784"	6721668,190	635819,482	354,62
Borgseter LPV	61 $^{\circ}$ 25'24,7539"	12 $^{\circ}$ 22'58,2546"	6814808,079	680475,193	688,08

Table A1.3 Long period array coordinates

## APPENDIX 2

### CABLE SPECIFICATIONS AND TESTING

#### A2.1 Cable for transmission of analog signals (and power) WHVs - DRC, STK type A12 - 0.91 EWBP - 52P (Figure A2.1)

##### Specifications

Specifications are based on US REA specifications PE-23 of January 1963; small deviations from these are specified.

Number of pairs	12
Conductors	0.91 mm Cu (19 AWG)
Insulation	0.375 mm PE

Colour code	1 Wh Blue 2 Wh Or 3 Wh Green 4 Wh Br 5 Wh Grey 6 Red/Blue 7 Red Or 8 Red Green 9 Red Br 10 Red Grey 11 Black Blue 12 Black Or
Inner mantle	1.3 mm PE, black (REA: 50 mils = 1.27 mm)
Shield	0.2 mm single coated aluminium/PE laminate +1 mm <sup>2</sup> tinned, flat-rolled copper litz wire
Outer mantle	1 mm thick, black PE, laminated to shield (REA: 1.02 mm) Outer diameter 16.5 mm
Sheath	2 layers of galvanized band steel, 18 mm x 0.3 mm each
Corrosion protection	1.3 mm PVC, black
Outer diameter	20.5 mm

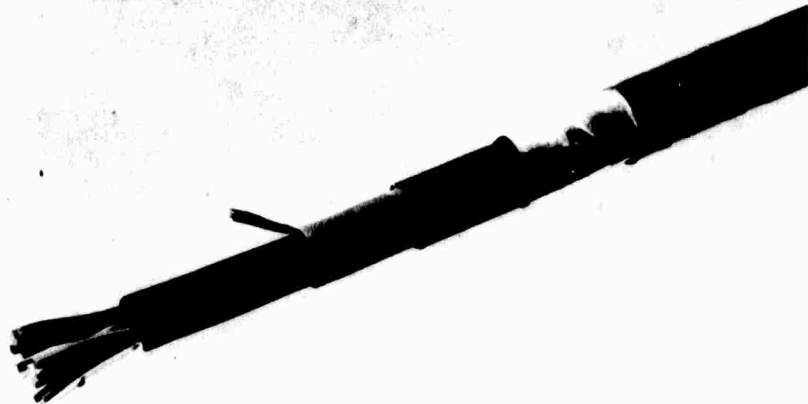

Figure A2.1 Signal cable

Testing

100% of delivered cable lengths have been subjected to the following tests:

High tension:

Conductor/conductor	4.5 kV DC for 3 seconds
Conductor/shield	20 kV DC " " "

Continuity and short circuits:

Shielding  
Pairs

Samples (50 - 70%) measurements:

Loop (pair) resistance	57.2 km at 20 <sup>o</sup> C
Unbalance	max mean 0.656 km
	max max 2.62 km
Insulation resistance	1600 megohm · km

Cross capacitance	min mean 47.3 nF/km max mean 56.0 nF/km
Pair/pair unbalance	max mean rms 40 pF/1000 ft max max 160 pF/1000 ft
Crosstalk at 150 kHz:	
Mean far-end crosstalk rms (a few measurements)	< 73 db/1000 ft
Pair/Shield unbalance	max mean 100 pF/1000 ft max max 500 pF/1000 ft
Air pressure test:	
Inner mantle	0.85 kp/cm <sup>2</sup>
Max pressure decay in 1 hr	0.07 kp/cm <sup>2</sup>

Splicing of signal cable

Figure A2.2 is a sketch depicting the splicing in principle.

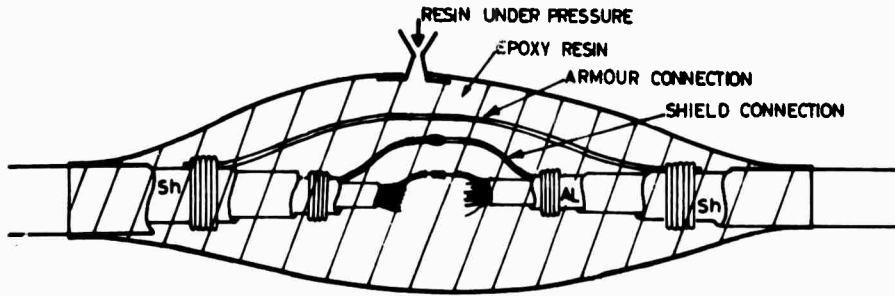

Figure A2.2 Signal cable splice  
Al - aluminium shield, Sh - sheath

A2.2 Communications cable, STK types

- L14-0.9 KABA - 37 D (earth cable)
- L14-0.9 KAWP - 37 D (overhead cable)

Specifications (NTA Specifications 14C)

	Earth	Overhead
No of pairs	14	14
Insulation	paper	paper
Shield	0.9 mm Al	1.1 mm Al
Inner mantle	1.5 mm PE	-
Sheath	20 x 0.5 band steel	7 x 1.4 mm galvanized support wire
Outer mantle (corrosion protection)	asphalt + jute	1.3 mm black PVC, cross section as figure 8
Cross capacitance	37 nF/km ± 5%	37 nF/km ± 5%
Side/side unbalance, max mean	40 pF/230 m	40 pF/230 m
max max	150 pF/230 m	150 pF/230 m

	Earth	Overhead
Side/earth,		
max mean	150 pF 230 m	150 pF/230 m
max max	600 pF 230 m	600 pF/230 m
Pair/pair,		
max	100 pF 230 m	100 pF/230 m

Testing (earth and overhead cable equivalent)

Insulation	10 000 megohm · km
High tension	
conductor/conductor	500 V DC
conductor/mantle	2000 V DC

### APPENDIX 3

#### SEISMOMETER AND WHV CIRCUITRY SPECIFICATIONS AND WIRING DIAGRAMS

##### A3.1 HS-10-1 (ARPA) SP seismometer specifications

Generator constant	846 V/m/sec at 3 c/s and 0.707 critical damping
Natural frequency	1.0 c/s $\pm 3\%$
DC resistance	50 000 ohms $\pm 5\%$ (coil centre tapped)
Moving mass	825 g $\pm 1.5\%$
Calibration coil	
Motor constant	0.0326 newtons/amp
Calibration coil	
Sensitivity	1 millimicron/microampere
Outer case test pressure	250 psi
Outer case dimensions	4.75 in. OD by 11.25 in. long

##### A3.2 LP seismometer specifications

###### Model 7505B LP vertical seismometer

DC power required	4.0 V DC, 150 mA 24 V DC, 350 mA 18 V DC, 1.5 mA
Weight	160 lbs (72.5 kg)
Dimensions	15.5 x 12 x 24 inches 393.7 x 304.8 x 609.6 mm
Natural period	10 to 30 sec, adjustable
Weight of inertial mass	10 kg $\pm 1\%$
Spring rate	10.3 lbs in. $\pm 3\%$
Critical damping resistance	90 times natural period, in ohms $\pm 3\%$
Transducer	
Type	Moving coil
Damping	Electromagnetic
Flux density in air gap	1950 $\pm 100$ gauss (max)

Coils

Data coil	
Number of coils	1
Terminal resistance	50 000 ohms $\pm 10\%$ at 25° C (77° F)
Turns	22 500
Wire size	No 47 AWG
Effective generator constant	750 V - s/m $\pm 2\%$
Calibration coil	
Number of coils	1
Terminal resistance	0.2 ohms $\pm 0.05$ ohms at 25° C (77° F)
Turns	1
Wire size	No 36 AWG
Effective motor constant	0.032 newtons/amp $\pm 0.0025$ newtons/amp
Damping coil	
Number of coils	1
Terminal resistance	580 $\pm 20$ ohms at 25° C (77° F)
Turns	3260
Wire size	No 36

Mass position monitor (mounted on seismometer)

Output	Zero to $\pm 1.5$ V DC, zero to $\pm 50$ $\mu$ A
Power required	18.0 V DC, 1.5 mA 4.0 V DC, 150 mA

Remote centering unit (mounted on seismometer)

Motor type	DC
Speed	60 rpm $\pm 10\%$
Power required	24 V DC, 100 mA

Remote centering device (external to seismometer)

Motor type	DC
Speed	60 rpm $\pm 10\%$
Power required	24 V DC, 350 mA

Environmental characteristics

Temperature	0° C to 60° C (32° F to 140° F) OPERATE -20° C to 60° C (-4° F to 140° F) STORAGE
Relative humidity	0 to 95% OPERATE
Altitude	15 000 ft OPERATE 50 000 ft STORAGE
Vibration	Zero (Operate) Will withstand all vibration encountered in normal shipping and maintenance (transit)
Shock	Will withstand all shocks encountered in normal shipping and maintenance

Model 8700D LP horizontal seismometer

DC power required	4.0 V DC, 150 mA 24 V DC, 350 mA 18 V DC, 1.5 mA
Weight	115 lbs (52.2 kg)
Dimensions	15.5 x 12 x 24 in. (394 x 305 x 610 mm)
Natural period	10 to 30 sec, adjustable
Weight of inertial mass	10 kg $\pm 1\%$
Transducer	
Type	Moving coil
Damping	Electromagnetic
Flux density in air gap	1950 $\pm 100$ gauss (max)

Coils

Data coil	
Number of coils	1
Terminal resistance	50 000 ohms $\pm$ 10% at 25° C (77° F)
Turns	22 500
Wire size	No 47 AWG
Effective generator constant	750 V - s/m $\pm$ 2%
Calibration coil	
Number of coils	1
Terminal resistance	0.2 ohms $\pm$ 0.5 ohms at 25° C (77° F)
Turns	1
Wire size	No 36 AWG
Effective motor constant	0.032 newtons/amp $\pm$ 0.0025 newtons/amp
Damping coil	
Number of coils	1
Terminal resistance	580 $\pm$ 10 ohms at 25° C (77° F)
Turns	3260
Wire size	No 36

Mass position monitor (mounted on seismometer)

Output	Zero to $\pm$ 50 $\mu$ A
Power required	18.0 V DC, 1.5 mA 4.0 V DC, 150 mA

Remote centering device (external to seismometer)

Motor type	DC
Speed	0.625 rpm $\pm$ 10%
Power required	24 V DC, 350 mA

A3.3 Type RA-5 amplifier specifications

Power

Voltage +18 V DC and -18 V DC

Current Dependent on number of boards used. A 3-channel basic system requires approximately 16 ma at +18 V DC. With the addition of three each 24 db/octave filters, three each 26 db/octave filters and six each differential output amplifiers, requirements are approximately 25 mA at +18 V DC and 5 ma at -18 V DC.

Signal channel

Input impedance Set by input attenuator if one is used. Without attenuator, will consist of a capacitive component of approximately 800  $\mu$ F in parallel with a resistive component of more than 1000 megohms.

Input noise voltage (equivalent) Less than 0.05  $\mu$ V rms over a frequency band from 0.8 to 10.0 cps.

Input type Differential and floating

Input voltage 30 mV-pp before clipping

Source requirements Resistive path of 50 megohms or less must appear across input terminals either by source or by resistor added at input terminals of data channel.

Frequency response	Without optional filtering, not more than 3 db down at 0.005 cps and 1200 cps
Preamplifier voltage gain	180 at detector output. Variable from 100 to 250
High-level output voltage gain	To customer's specifications
Offset output voltage	
Detector output	Adjustable, 6 V DC ( $\pm 2$ V DC)
Multilevel amplifier	Adjustable, normally set at 0 V
Differential amplifier	Adjustable, normally set at 0 V
Output signal level	
Detector output	Minimum of 8 V-pp before clipping
Multilevel amplifier	Minimum of 28 V-pp with $\pm 18$ V DC power source
Differential amplifier	Minimum of 56 V-pp differential $\pm 18$ V DC power source
Dynamic range	
Detector output	106 db with gain of 180
High-level amplifier output	100 db with overall single-ended gain of 1000
Output impedance	
Multilevel amplifier	Less than 5 ohms
Differential amplifier	5 ohms, each leg
Filter Response	All similarly specified 3 db points ( $\pm 1$ db) will track from channel to like channel
Crosstalk	At least 54 db down between channels
Environmental gain stability	
Temperature	Not more than 3 db variation from nominal over a temperature range from $-30^{\circ}$ C to $+50^{\circ}$ C
Power	Not more than 1 db variation from normal with change in positive supply from +15 V to +28 V or with negative supply change from -15 V to -28 V.
Detector DC offset variations related to temperature changes	Not more than $\pm 3$ V DC change with temperature change from $-30^{\circ}$ C to $+50^{\circ}$ C
Shock	Will withstand normal shipment by commercial carrier including air freight
Physical	
Size	7 in. x 5 in. x $13\frac{1}{2}$ in.
Weight	Dependent on number of boards. Basic system weighs approximately 45 oz

#### A3.4 AB and IB circuitry diagrams

Figures A3.1 through A3.8 give details of the WHV circuitry except for internal RA-5 amplifier.



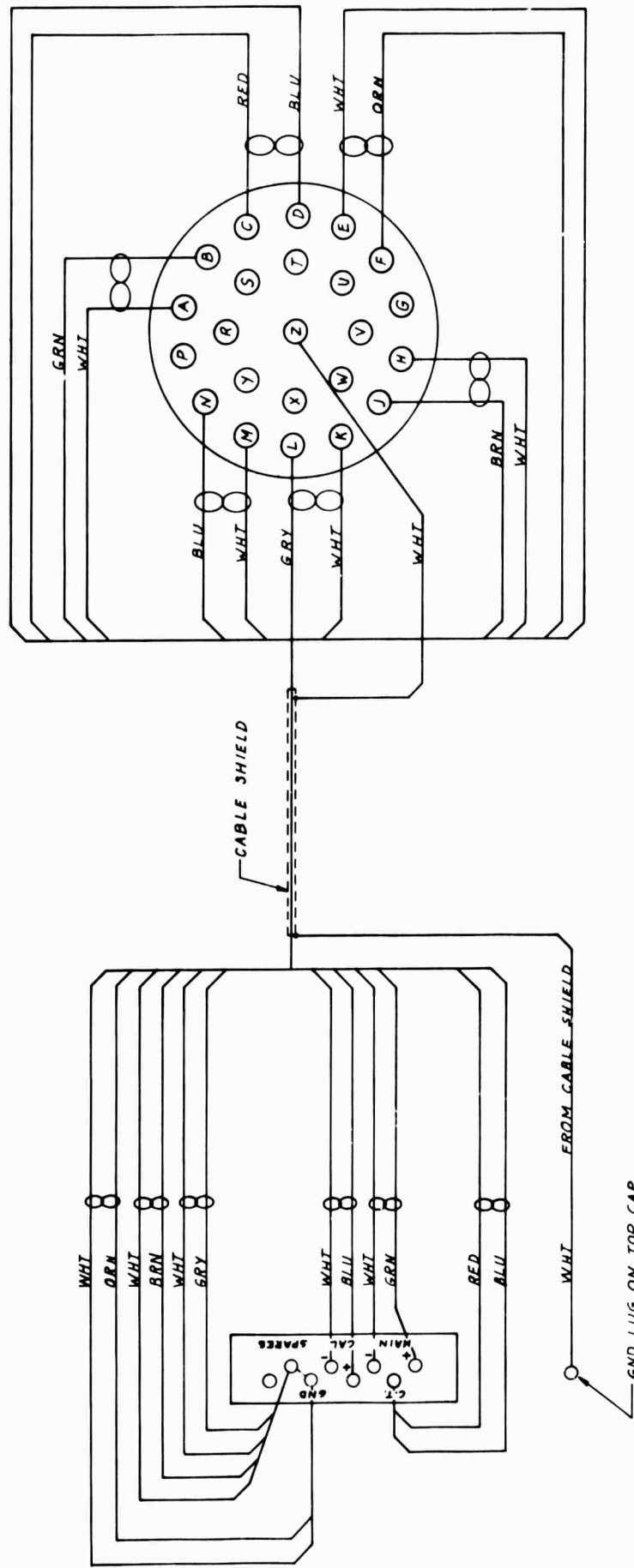

CANNON PLUG KPT06F16-23PW  
(MATES WITH J1(KPT07E16-235W) IN AMPL. BOX)

SEISMOMETER

Figure A3.1 SP seismometer to amplifier box connections

TO  
J. BOX

FROM  
SEISMOMETER

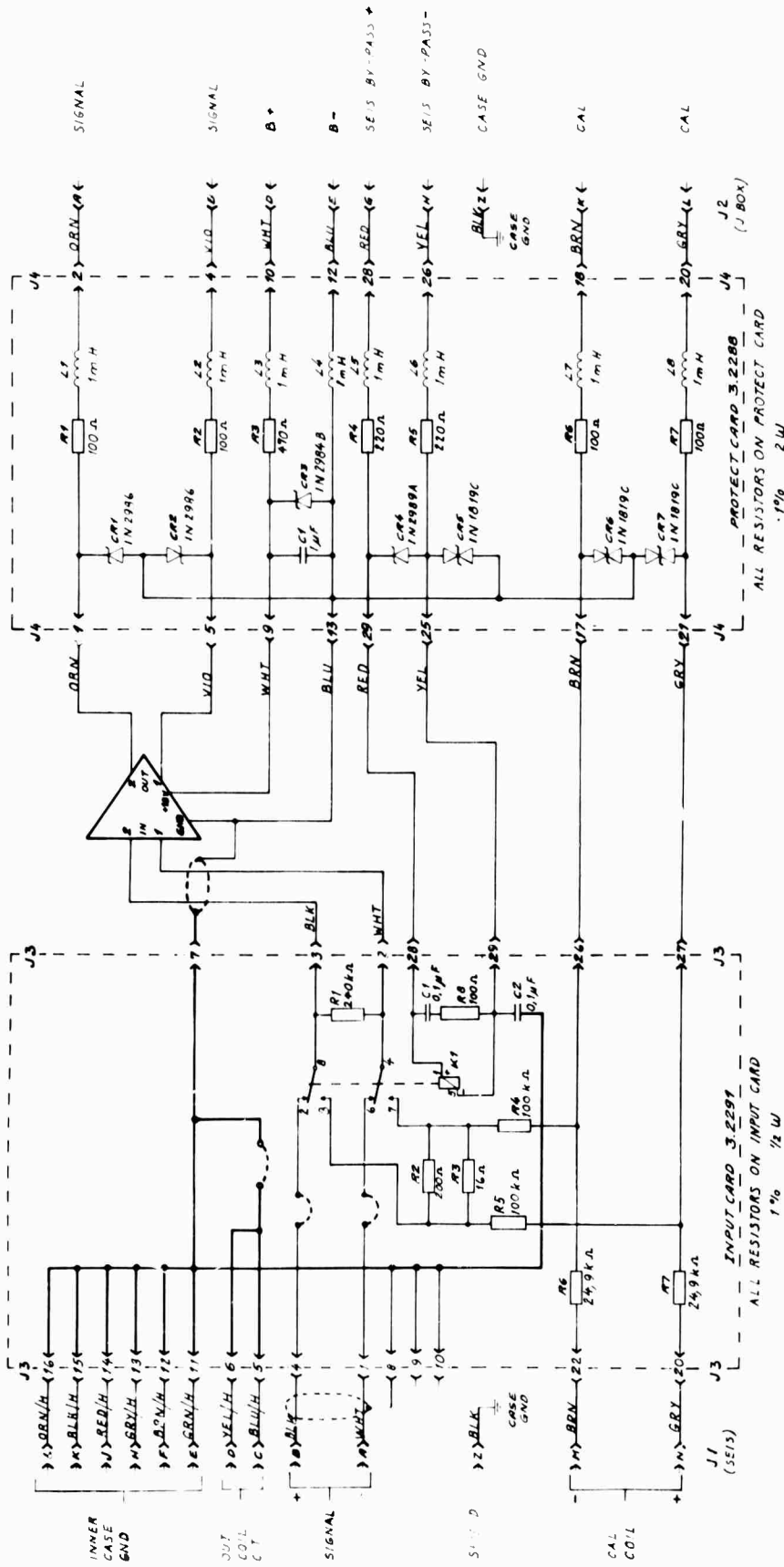

NOTE: SHIELDED WIRING TO BE YF-05-K 2x0.15mm<sup>2</sup> GRAY  
ALL OTHER WIRING TO BE SOFLEX TQ 0.15mm<sup>2</sup> (30x0.10)

Figure A3.2 Amplifier box, wiring diagram

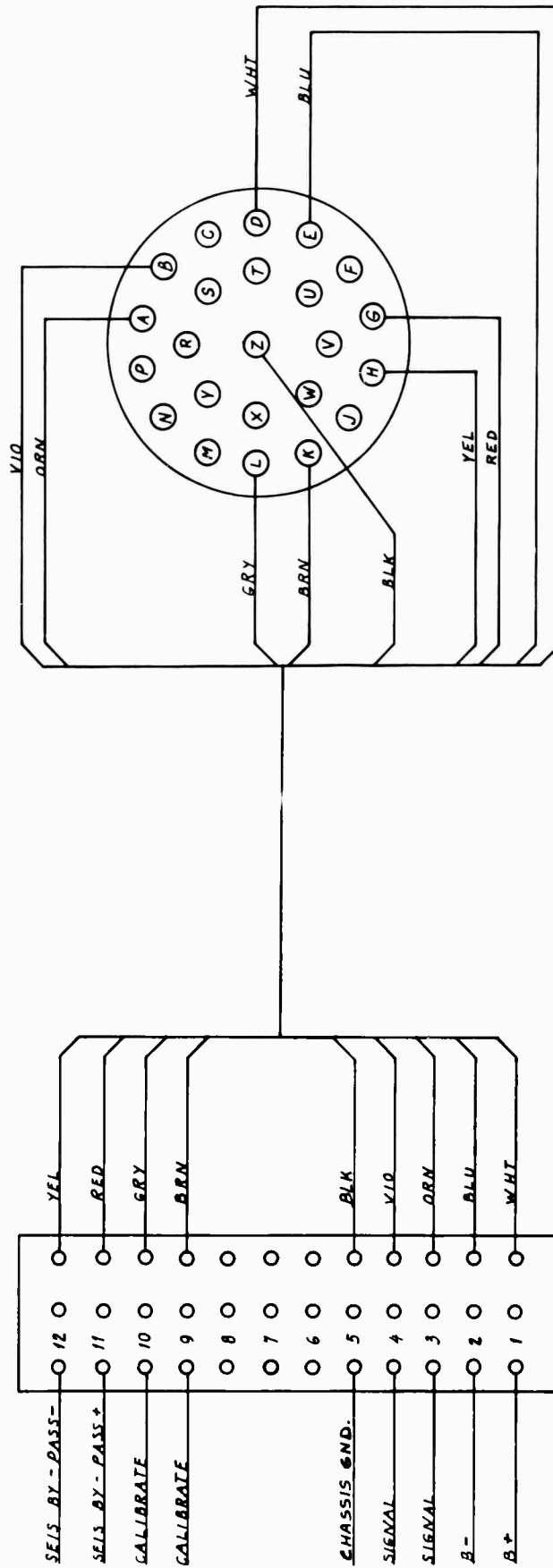

TAPER PIN BLOCK "E"  
( JUNCTION BOX )

CANNON PLUG KPT06F16 - 23P  
(MATES WITH J2(KPT07E16-23S) IN AMPL. BOX)

Figure A3.3 Amplifier box to junction box connections

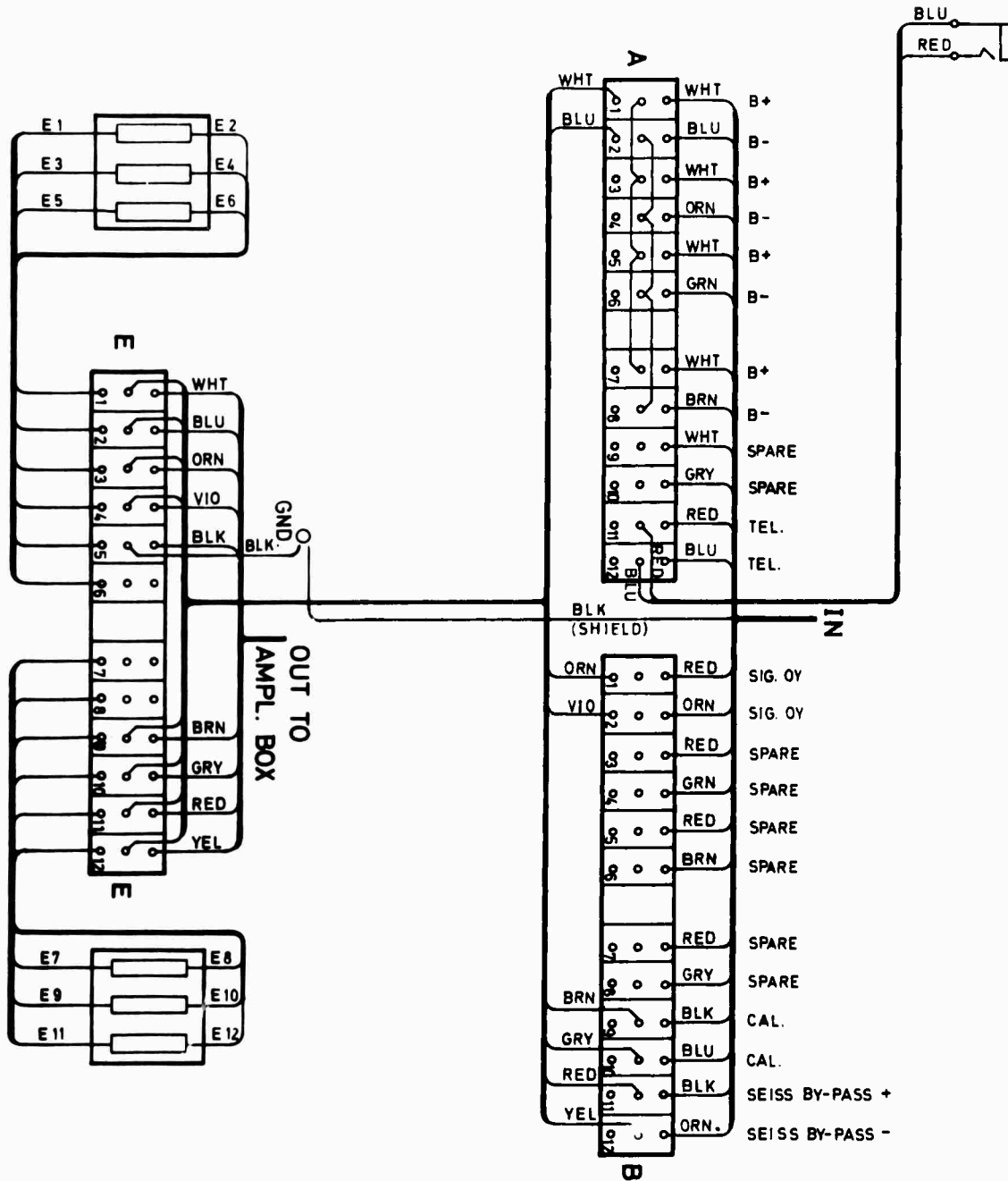

Figure A3.4 Junction box. wiring diagram; type 10Y(1)

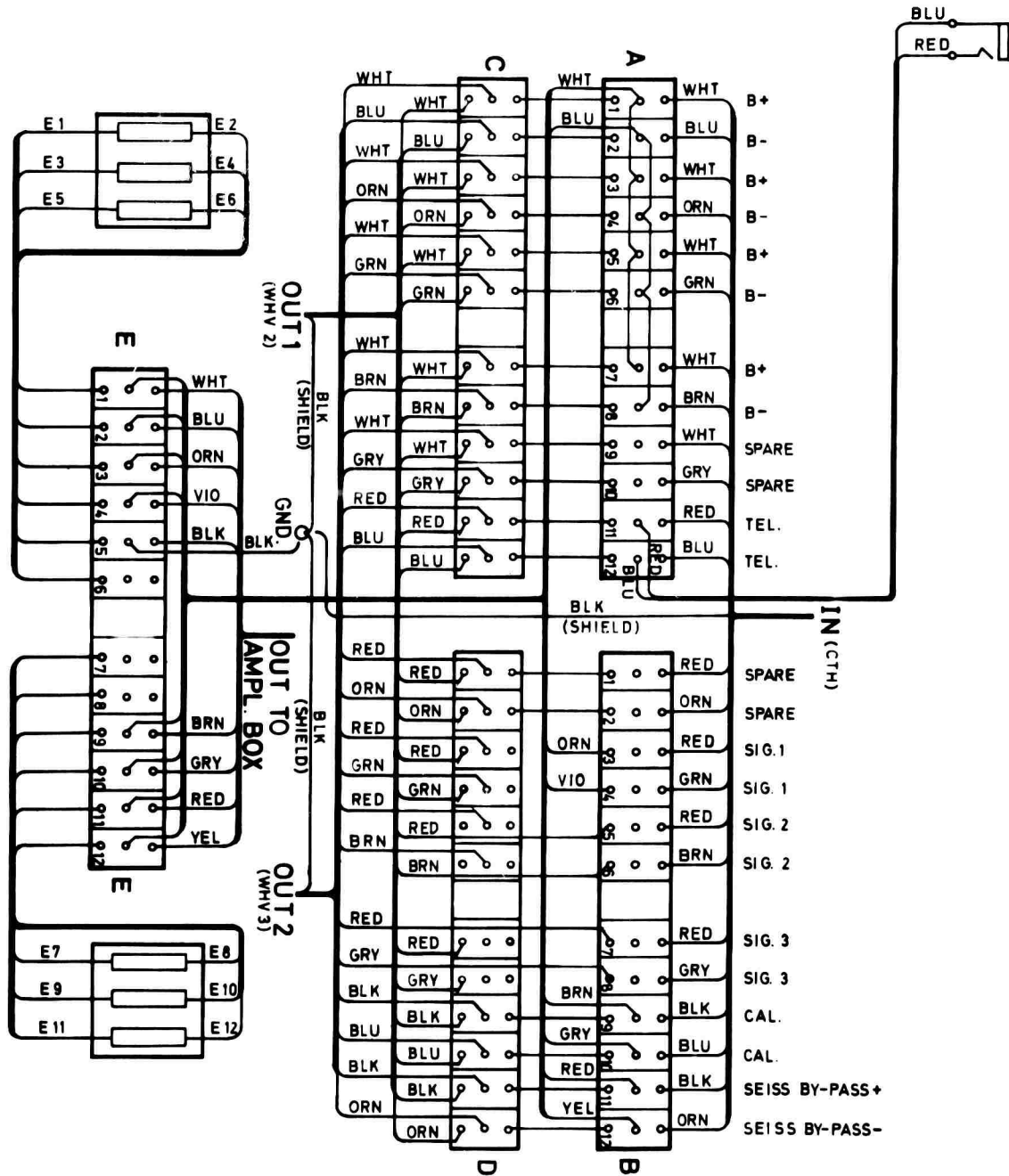

Figure A3.5 Junction box, wiring diagram: type branching point inner hexagon

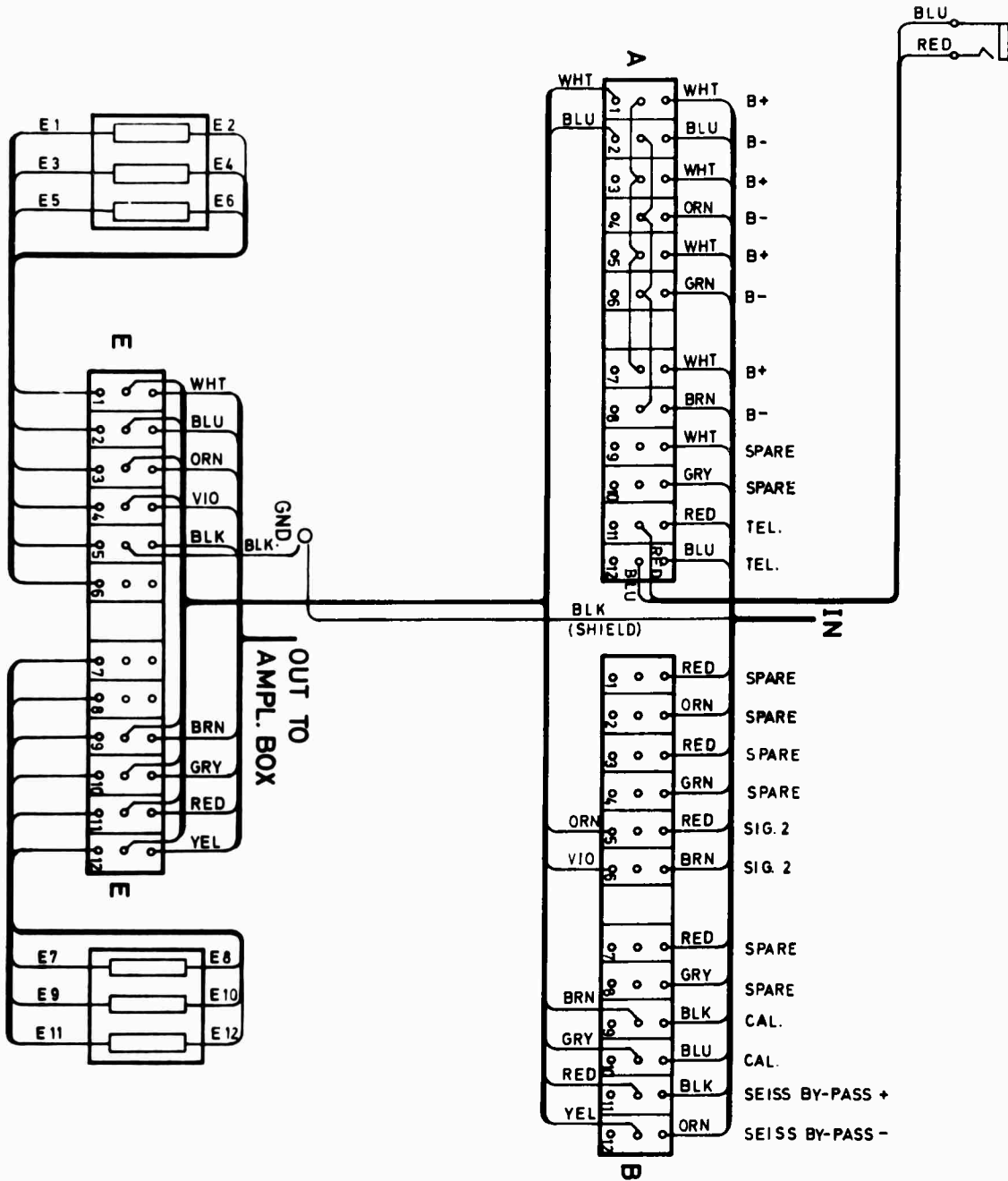

Figure A3.6 Junction box wiring diagram; type outer hexagon, left branch

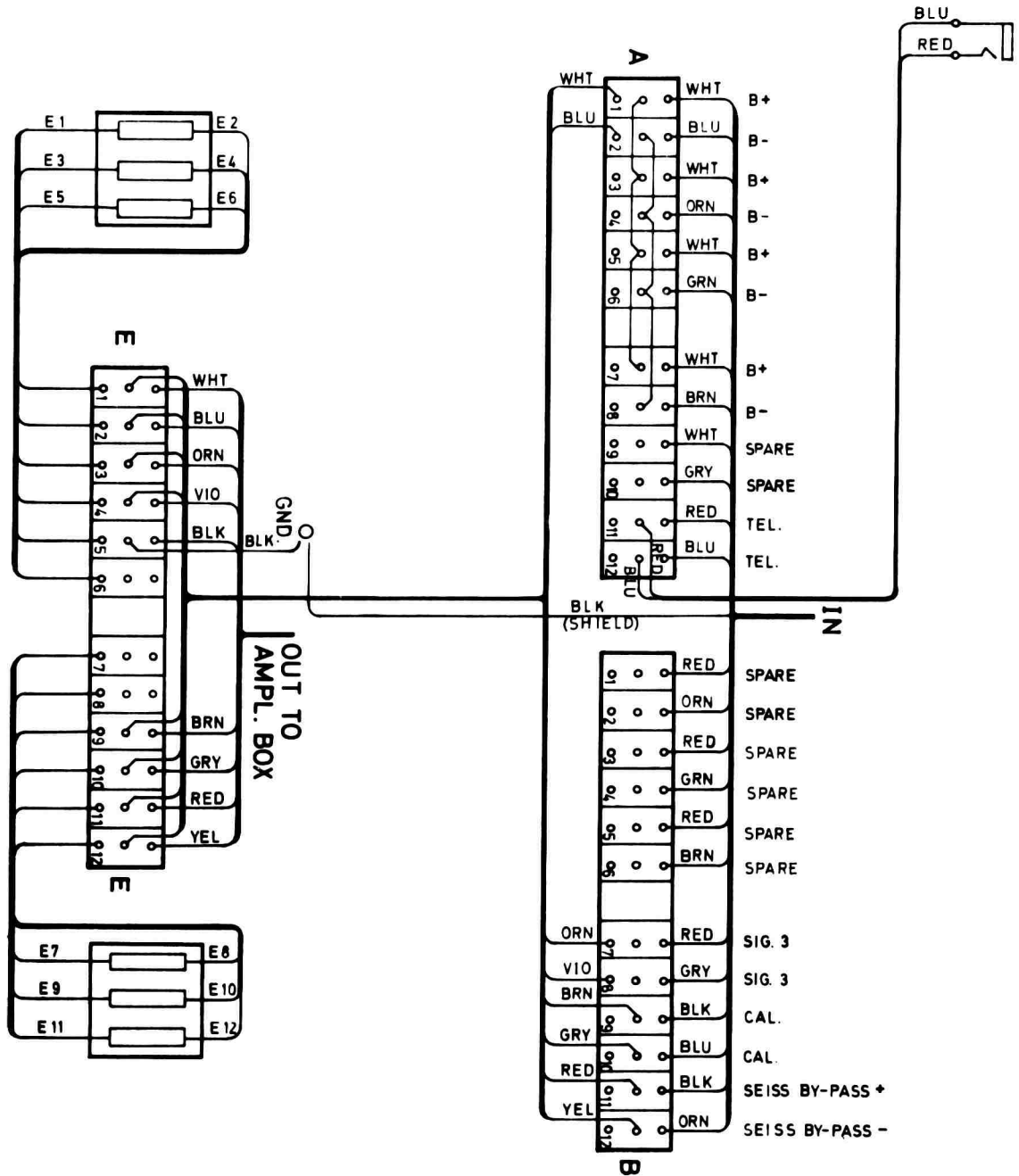

Figure A3.7 Junction box wiring diagram; type outer hexagon, right branch

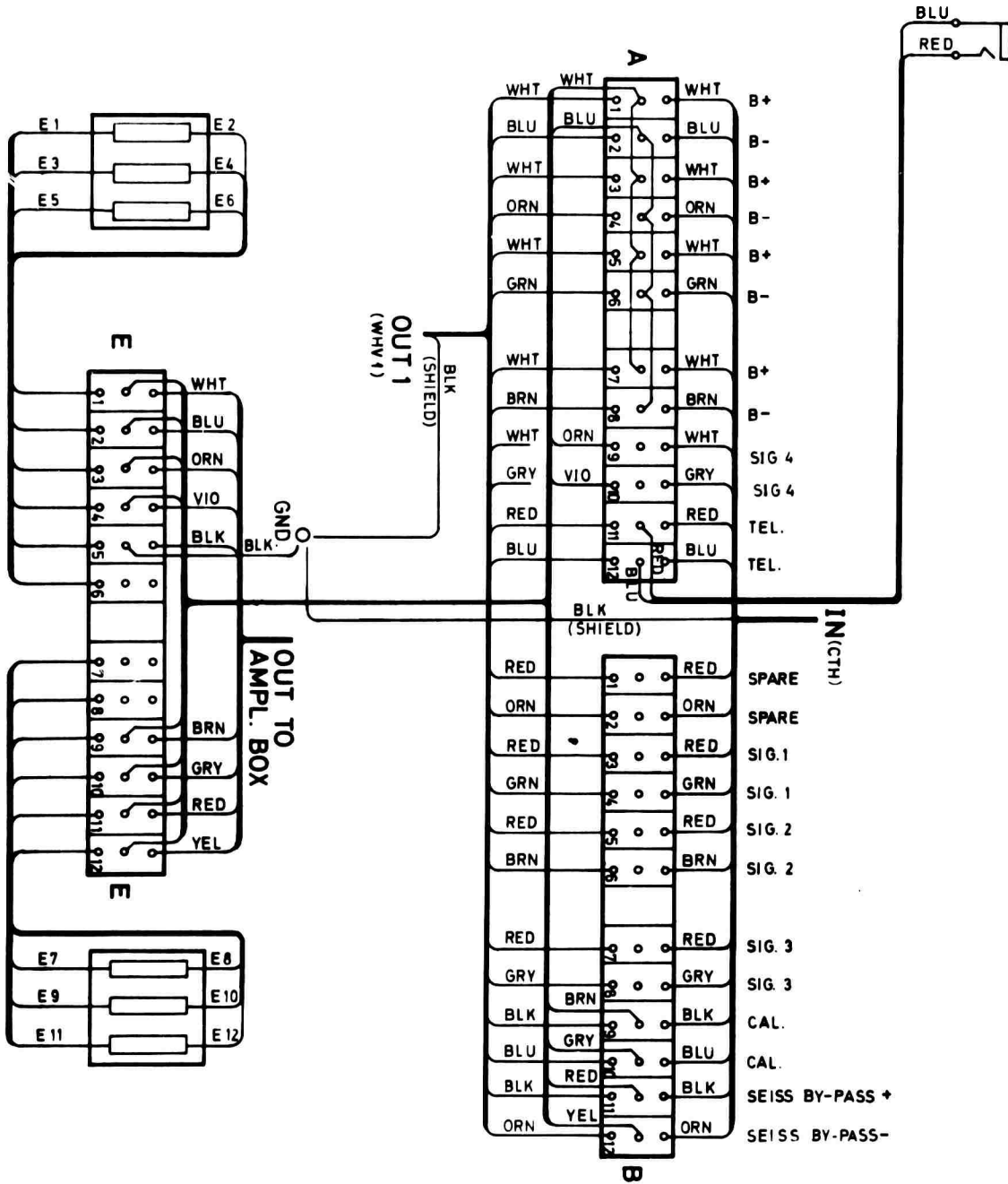

Figure A3. 8 Junction box wiring diagram: type 1F4(20)



APPENDIX 4

DATA CONCERNING BOREHOLE DRILLING

A4.1 Statistics, drilling and casing operations

Borehole number	Transport	Drilling		Casing	Overburden		Delays		Remarks
	Manh	Manh	Mach h	Manh	Digging Manh	Drilling Machh	Manh	Mach h	
1OY (1)	19		16.5	5	25		7	10	
1C1 (2)	43		19.0	4	18			22	
1C2 (3)	93.5		13.5	6	30			30.5	
1B3 (4)	23		7				38	58	
1B1 (5)	73		23.5	6	12		15	17.5	
1B2 (6)	9		6				70	43.5	
1A3 (7)	24		6	12	12		16	15.5	
1A1 (8)	116	42	42.5	70.5	39		49.5	125.5	Cave-in of hole
1A2 (9)	25.5		6.5	6	9			3	
1F3 (10)	71		11.5	10	15		6	36	
1F1 (11)	29		16	14.5	9			15	
1F2 (12)	51		10	12	9			21.5	
1E3 (13)	152.5		3.5	8	13			101	
1E1 (14)	70		12.5	17	15			20	
1E2 (15)	3						20	11.5	Not finished
1D3 (16)	34		15.5	15	25			9	
1D1 (17)	42		11	6	4.5		4	17.5	
1D2 (18)	33		25	5	17.5		8	18	
1C3 (19)	156	36	13	39	94		28.5	128.5	Snow difficulties
1F4 (20)	136		15.5	34	87	72.5	10	186.5	Very deep deposit
Totals	1203.5	78	274	270	434	72.5	272	890	

Table A4.1 Statistics, individual boreholes  
(Manh - man hours, Machh - machine hours)

Transport	Drilling	Casing	Overburden digging	Delays	
50 manh/hole	12.7 drillh/hole	7.9 manh/hole	13.4 manh/hole	10.3 manh/hole	27.4 machh/hole

Table A4.2 Average for 16 holes  
(Holes 1A1(8), 1E2(15), 1C3(19) and 1F4(20) are excluded from average)

A4.2 Drilling reports

Tables A4.3 through A4.27 are detailed reports covering all drilling and casing operations.

PROJECT: <i>Nannegren Seismic System Phase I</i> INSPECTOR: <i>Rugaas-Raaen</i> SITE: <i>By Miksjokampen</i> DRILLING MACHINE: <i>H.S. 5</i> DRILLING FOREMAN: <i>Selvik Jr.</i> DIAMETER: <i>158 mm until 12 m</i> <i>155 mm last 5 m</i> BOREHOLE NO: <i>10Y111</i>														
DATE	START/STOP TIME	ROCK DRILLING DEPTH - M	OVER-BURDEN DEPTH - M	DRILLING CASING DEPTH - M	GR W LEVEL DEPTH - M	INCLINATION ANGLE - M	ROUTING GROUTING (CM)	WELDING (M)	MOUNTING HOURS	BACKFILL HOURS	TRANSPORT FROM TO HOURS	DELAY HOURS	ROCK DESCRIPTION	REMARKS
19/9														
19/9		10										13		<i>4 waiting for tractor</i>
19/9		5	1.5	1.4	6.0	15.0	3/4	10.72					<i>Light sandstone</i>	<i>4 h mounting of drilling</i>
19/9												35		<i>35 h tractor-transport</i>
"												30	<i>(Penetration rate)</i>	<i>30 h tractor-excavating</i>
"													<i>No drilling problems</i>	<i>10 Machinehours</i>
21/9														
23/9												12 <sup>00</sup>		<i>Transport of pipes, 2m</i>
24/9	7:00									2	15 <sup>00</sup>	6		<i>Digging for head, 2m</i>
"	7:00								20					<i>2m (Mounting backfill, 1m plane leveling)</i>
"	7:00							5						
"														
"														
"														
"														
"														
"														
"														
"														
"														

Table A4.3 Drilling report hole 10Y(1)

PROJECT: Norwegian Seismic System Phase I															INSPECTOR: Rugaas-Raaen															Side 1														
SITE: By Nysætra															DRILLING MACHINE: Perfo 66 and HS 5															DRILLING FOREMAN: Selvik Jr.														
BOREHOLE NO: 1A1 (8)															DIAMETER: 158 mm																													
DATE	START TIME	STOP TIME	ROCK DRILLING DEPTH - M	OVER-BURDEN DRILLING DEPTH - M	GRW LEVEL INCLINATION ANGLE - M	WELDING (M)	ROUTING (M)	ROUTING (M)	HOUNTING HOURS	BACKFILE HOURS	TRANSPORT FROM TO HOURS	DELAY HOURS	ROCK DESCRIPTION	REMARKS																														
17/9											11:00 13:00	4		Transp from 10Y(1) to road, 2m																														
"											11:00 13:00		Dark sparagymite	2 Machine hours																														
19/9											7:00 8:00	2		Transp along road, 2m																														
"											8:00 9:00		Penetration rate 1.2 m/hour	Waiting for tractor, 2m																														
"											9:00 17:00	16	Low value because of water	Transp. from road to 1A1(8) 2m																														
"											7:00 17:00			10 Machine hours																														
24/9											7:00 12:00	10	6m deep fault	Digging another hole, 2m																														
"											7:00 12:00			5 Machine hours																														
"	15:30	16:00	05																																									
"	16:00	18:30	50	275	20																																							
24/9	8:00	18:30	85																																									
27/9	7:00	11:00	15																																									
														The hole collapsed immediately after the drilling. The collapse happened ca 6 m from the surface. Attempts were made to drill it out, but useless.																														
17/10											7:00 14:00	14		Transp of drilling equipment from 1E3(13) to 1A1(8), 2m																														
"											7:00 19:00			12 Machine hours																														
19/10											7:00 17:00	20		Transp of drilling equipment from 1E4(20) to 1A1(8), 2m																														
"											7:00 17:00			10 Machine hours																														
20/10											7:00 17:00	30		Attempt at drilling, 3m																														
											7:00 17:00			10 Machine hours																														
21/10											7:00 14:00	14		Waiting for tractor excavator, 2m																														
"											7:00 14:00			7 Machine hours																														

Table A4.4 Drilling report hole 1A1(8), page 1

PROJECT: Norwegian Seismic System Drilling Machine: Perfo bb and H.S.5															INSPECTOR: Raean		Side 2			
SITE: By Mysestra															DRILLING FOREMAN: Selvik Jr					
BOREHOLE NO: 1A1(8)																				
DATE	STOP TIME	ROCK DRILLING DEPTH-M	OVER-BURDEN DRILLING DEPTH-M	GR W LEVEL	INCLINATION	GRROUTING	WELDING	HOISTING	BACKFILL	TRANSPORT	DELAY	ROCK DESCRIPTION	REMARKS							
				DEPTH-M	ANGLE	DEPTH-M	M	HOURS	HOURS	FROM TO	HOURS									
22/6										7:00 14:00	7		Waiting for tractor excavator, 1m							
"										7:00 14:00			7 Machine hours							
23/6										7:00 18:30	11.5		Waiting for excavator, 1m							
"										7:00 13:00	6									
"										7:00 18:30			11.5 Machine hours							
24/6										7:00 17:30 21			Digging a ditch, 2 m							
"										7:00 17:30			10.5 Machine hours							
24/6										7:00 11:00 8			Digging and rigging, 2 m							
"	11:00 15:00	40	40							7:00 11:00		Dark sparagmite								
"										7:00 11:00			4 Machine hours							
"										15:00 17:30 9			Waiting time, 2 m							
"										15:00 17:30			4.5 Machine hours							
"										15:00 17:30 10			Transp of pipes from depot to 1A1(8), 20km							
25/6										7:00 18:00			11 Machine hours							
"										7:00 18:00 22			Transport, 2 m							
27/6										7:00 18:00			11 Machine hours							
"										7:00 18:00 22			Transport, 2 m							
29/6										7:00 17:00			10 Machine hours							
"										7:00 15:00 12			Attempt at drilling, 2 m							
"										15:00 17:00 16			Growing in hole, 4 m							
29/6	8:00 17:00	7.5	7.5																	

Table A4.5 Drilling report hole 1A1(8), page 2

PROJECT: Norwegian Seismic System Phase I															
SITE: By Nysætra				INSPECTOR: Raaen-Rugaas											
BOREHOLE NO: 1A1 (B)				DRILLING MACHINE: H S 5											
DIAMETER: 158 mm				DRILLING FOREMAN: Selvik											
SIDE 3															
DATE	START TIME	STOP TIME	ROCK DRILLING DEPTH (m)	OVER-BURDEN DEPTH (m)	DRILLING DEPTH (m)	GRW LEVEL DEPTH (m)	INCLINATION ANGLE (M)	GRDITING (m)	WELDING (m)	ACOUNTING HOURS	BATIFILL HOURS	TRANSPORT FROM TO HOURS	DELAY HOURS	ROCK DESCRIPTION	REMARKS
3/10	7 <sup>00</sup>	17 <sup>30</sup>	6	135				31							
3/10	7 <sup>00</sup>	17 <sup>30</sup>	24	159	10	09	145	16°	151	1043				Dark sandstone	
1/10												7 <sup>00</sup>	8 <sup>00</sup>	3	Transport, 3m
"												16 <sup>00</sup>	17 <sup>00</sup>	3	Transport in return, 3m
"												7 <sup>00</sup>	13 <sup>00</sup>	13	Mounting, grouting, 2m
"												8 <sup>00</sup>	16 <sup>00</sup>	205	Casing, 5m
3/10												7 <sup>00</sup>	15 <sup>00</sup>	13	Mounting, 2m
															Transp by tone 60Am

Table A4.6 Drilling report hole 1A1(B), page 3

DATE	START/STOP TIME	ROCK DRILLING DEPTH - m	OVER BURDEN DRILLING DEPTH - m	DIAMETER - m	BRIDGING	WELDING	BACKFILL	TRANSPORT	DELAY	ROCK DESCRIPTION	REMARKS
19/9								8:00	11:50		3h Tractor excavating
19/9								8:00	11:00	Dark sparagmite	2 m 3 Machine hours
20/9	11:30	150	14:30	0.8	2.80	20	32	14:5	17:55	Penetration rate 3.3 mm/m	Transp of grouting equipment by car, 35 km
30/9								7:00	10:00		Transp of pipes, 2 m, by car, 35 km
4/10								4:00	6:00		Transp of compressor, 35 km by car, 35 km
15/10	8:00	15				31 14	11.45				2 m
16/10	8:00	14						4:00	16:30		2 m returning with drilling equipment by car, 35 km

PROJECT: Norwegian Seismic System  
Phase I  
SITE: Byåsen

INSPECTOR: Rugeas - Raaven  
DRILLING FOREMAN: Selvik Jr

DRILLING MACHINE: HS 5  
DIAMETER: 158 mm until 10 m  
155 mm last 5 m

BOREHOLE No. 1A2 (9)

Table A4.7 Drilling report hole 1A2(9)

PROJECT: Norwegian Seismic System DRILLING MACHINE: HS 5 SITE: By Støren DIAMETER: 158 mm BOREHOLE NO: 1A3(7)														
INSPECTOR: Rugaas DRILLING FOREMAN: Selvik jr														
DATE	START/STOP TIME	ROCK DRILLING DEPTH, m	OVER-BURDEN DEPTH, m	DRILLING DEPTH, m	CASING DEPTH, m	INCLINATION ANGLE, °	ERODING RATE, m/hr	WELDING, m	MOUNTING, HOURS	BACKFILL, HOURS	TRANSPORT FROM TO, HOURS	DELAY, HOURS	ROCK DESCRIPTION	REMARKS
20/6											7 <sup>00</sup> 11 <sup>00</sup>	0		Waiting for tractor, 2 m
"											11 <sup>00</sup> 10 <sup>00</sup>	13		Transp of drilling equipm 2 m. 11 Machine hours
21/6											7 <sup>00</sup> 11 <sup>00</sup>	0	Dark sandstone	Waiting for tractor, 2 m
"											11 <sup>00</sup> 13 <sup>00</sup>	5		Transp of drilling equipm 2 m. 6.5 Machine hours
22/6	0 <sup>45</sup> 11 <sup>15</sup>	06		12	10			10.55					Penetration rate 26.4 mm/hr	
19/10											7 <sup>00</sup> 8 <sup>00</sup>	3		3 m
"											14 <sup>00</sup> 15 <sup>00</sup>	3		3 m
21/10											7 <sup>00</sup> 11 <sup>00</sup>	12		Mounting, 3 m
"											11 <sup>00</sup> 15 <sup>00</sup>	12		Plane levelling, 3 m
														Transport by lorry 99 + 88 km = 187 km

Table A4 8 Drilling report hole 1A3(7)

INSPECTOR: *Rugaas-Raaen*  
 DRILLING FOREMAN: *Selvik Jr*

PROJECT: *Norwegian Seismic System*  
 DRILLING MACHINE: *H S 5*  
 DIAMETER: *150 mm*

SITE: *By Dyopia*

BOREHOLE NO: *1B1(5)*

DATE	START STOP TIME	ROCK DRILLING DRILLED DEPTH M	CASING DEPTH M	OVER BURDEN DRILLING DRILLED DEPTH M	CASING DEPTH M	DRILLING DEPTH M	GR W LEVEL	INCLINATION ANGLE M	GROUTING (QTY)	WELDING M	HOISTING HOURS	BACKFILL HOURS	TRANSPORT FROM TO HOURS	DELAY HOURS	ROCK DESCRIPTION	REMARKS
1/11													7 <sup>00</sup> 17 <sup>00</sup>			10 Machine hours
"													7 <sup>00</sup> 17 <sup>30</sup>			Transp 3m
2/11	7 <sup>00</sup> 15 <sup>00</sup>	70											7 <sup>00</sup> 12 <sup>00</sup>			5 Machine hours
3/11													7 <sup>00</sup> 12 <sup>00</sup>			ABL Snow difficulties
"													7 <sup>00</sup> 12 <sup>00</sup>			ABL Snow difficulties
3/11	12 <sup>00</sup> 19 <sup>30</sup>	50	120													Transp by lorry from Aknesvatn to 1B1(5)
4/11	7 <sup>00</sup> 15 <sup>00</sup>	32	152 <sup>4</sup>	16	14	3.5	15.50	0.9°	3/ 1.40	10.32			15 <sup>00</sup> 17 <sup>30</sup>			Penetration rate 0.65 m/hr
"													15 <sup>00</sup> 17 <sup>30</sup>			Transport, 3 m
"													15 <sup>00</sup> 17 <sup>30</sup>			Low value because of machine defect
4/11													13 <sup>00</sup> 15 <sup>00</sup>	6		2.5 Machine hours
4/11													7 <sup>00</sup> 14 <sup>30</sup>	22.5		Lorry transport, 20km Lorry transp of pipes 3m, 3.1 km
8/11	7 <sup>00</sup> 13 <sup>00</sup>										6	12				Transp from road to 1B1(5)
9/11													4 <sup>00</sup> 17 <sup>30</sup>	7		3m
																Return transp. by lorry 3.2 km, 2 km

*9) The lowest 95 cm collapsed. Impossible to blow out. The depth of hole was measured to be 14.825 m*

Table A4.9 Drilling report hole 1B1(5)



PROJECT: <i>Norwegian Seismic System Phase I</i> DRILLING MACHINE: <i>H-S-5</i> INSPECTOR: <i>Rugaas</i> SITE: <i>Bytautra</i> DIAMETER: <i>150 mm</i> DRILLING FOREMAN: <i>Sevrik jr</i> BOREHOLE NO: <i>1B2(6)</i>															
DATE	START/STOP TIME	ROCK DRILLING DEPTH - M	OVER-BURDEN DEPTH - M	DRILLING CASING DEPTH - M	GROUTING ANGLE - M	GROUTING DEPTH - M	WELDING DEPTH - M	HOISTING HOURS	BACKFILL HOURS	TRANSPORT FROM TO HOURS	DELAY HOURS	ROCK DESCRIPTION	REMARKS		
2/10										7:00 10:00	9		Transp of compressor		
3/10										10:00 19:00	10	Dark speckle granite	35 Machine hours, 3m		
4/10										7:00 19:00	24		Waiting time for helicopter		
5/10										7:00 12:00	10	Penetration rate 30 %/hour			
9/10	8:00 17:00									12:00 19:00	10		Rep of drilling equipment		
9/10	9:00 15:00	150				0.85 / 35	0.3								

Table A4.10 Drilling report hole 1B2(6)

PROJECT: Norwegian Seismic System Phase I														INSPECTOR: Raden				
SITE: By Sjølystsestra														DRILLING FOREMAN: Semik J.				
BOREHOLE NO: 1B3(4)																		
DIAMETER: 158 mm																		
DRILLING MACHINE: H S 5																		
DATE	START/STOP TIME	ROCK DRILLING DEPTH (M)	CASING DEPTH (M)	OVER BURDEN DEPTH (M)	DRILLED DEPTH (M)	CASING DEPTH (M)	DEPTH (M)	GR W LEVEL	INCLINATION ANGLE (M)	BROUTING (M)	WELDING (M)	MOUNTING HOURS	BACKFILL HOURS	TRANSPORT FROM TO HOURS	DELAY HOURS	ROCK DESCRIPTION	REMARKS	
9/10														16:00	17:00	2		Making ready for heliport transp 2 m
"														16:00	17:00			1 Machinehour
14/10														7:00	12:00	15	Dark sparagmite	Making ready for heliport transp 3 m
"														12:00	14:00	6	Penetration rate 22 %	Helicopter transp 3 m
"														7:00	19:00			12 Machinehours
11/10														7:00	19:00	23		Transp + wait for heliport, 2 m
"														7:00	19:00			12 Machinehours
14/10														7:00	12:00	15		3 m repairing compressor because of rough heliport
"														7:00	12:00			5 Machinehours
"	12:00	17:00	125	125		05	126	17										
13/10	9:00	1:00	25	150														
"																		
14/10														12:00	19:00			7 Machinehours
17/10														7:00	19:00			12 Machinehours
														7:00	16:00			9 Machinehours

Table A4.11 Drilling report hole 1B3(4)

PROJECT: <i>Norwegian Seismic System Phase I</i>													
INSPECTOR: <i>Raen</i>													
DRILLING FOREMAN: <i>Selvik jr.</i>													
DRILLING MACHINE: <i>H.S. 5</i>													
DIAMETER: <i>158 mm</i>													
BORE-HOLE NO: <i>1C1 (2)</i>													
DATE	START/STOP TIME (FM)	ROCK DRILLING DEPTH (M)	OVER-BURDEN DRILLED (M)	DRILLING DEPTH (M)	CASING DEPTH (M)	GRW (LEVEL)	ANGLE (M)	WELDING (M)	MOUNTING (HOURS)	BACKFILL (HOURS)	TRANSPORT FROM TO (HOURS)	DELAY (HOURS)	REMARKS
10/10											7 <sup>00</sup> 19 <sup>00</sup>	23	Transport of drilling equipment from road to hole no 1C1(2), 2m
"											7 <sup>00</sup> 19 <sup>00</sup>		12 h Machinehours
11/10	12 <sup>00</sup> 19 <sup>00</sup>	5.0		3.0									Light sparagmite
13/10	7 <sup>00</sup> 16 <sup>00</sup>	10.5		13.5									Partial rep of drilling equipment
14/10	8 <sup>00</sup> 19 <sup>00</sup>	-		13.5									12 h. Rep of drilling equipment
15/10	9 <sup>00</sup> 13 <sup>00</sup>	1.5	1.45	13.92	1.25	0.4	4.5	18°			7 <sup>00</sup> 11 <sup>00</sup>	8	Transp for casing, 2 m
23 "													
24/10											7 <sup>00</sup> 10 <sup>00</sup>	12	Transp for casing, 4 m
"											10 <sup>00</sup> 11 <sup>00</sup>	4	Transport, 4 m
27/10	7 <sup>00</sup> 11 <sup>00</sup>							37	4	12			4 m (Mounting, backfill, 3m) plane leveling
"	11 <sup>00</sup> 13 <sup>00</sup>						14	6					

Table A4.12 Drilling report hole 1C1(2)

PROJECT		DRILLING MACHINE		INSPECTOR		DRILLING FOREMAN		REMARKS				
Norwegian Seismic System Phase I		H.S.5		Razen		Selvik Jr						
SITE: ca 2km east Hareidufjorden		DIAMETER: 158 mm										
BOREHOLE NO: IC2 (3)												
DATE	START/STOP TIME	ROCK DRILLING DEPTH - M	OVER-BURDEN DEPTH - M	DRILLING DEPTH - M	GRW LEVEL INCLINATION - M	GRROUTING - M	WELDING - M	MOUNTING HOURS	BACKFILL HOURS	TRANSPORT FROM TO HOURS	DELAY HOURS	REMARKS
21/10										7 <sup>00</sup> 18 <sup>00</sup> 33		Transp of drilling equipment 3m
"										7 <sup>00</sup> 18 <sup>00</sup>		11 Machinehours
22/10										8 <sup>00</sup> 17 <sup>00</sup> 18		Transp of drilling equipment 2m
"										7 <sup>00</sup> 17 <sup>00</sup>		10.5 Machinehours
"												2x10 km by truck
23/10										7 <sup>00</sup> 12 <sup>00</sup> 10		Transp of drilling equipment 2m
"										7 <sup>00</sup> 12 <sup>00</sup>		5 Machinehours
24/10										7 <sup>00</sup> 11 <sup>00</sup> 12		Transp of drilling equipment 3m
"										7 <sup>00</sup> 11 <sup>00</sup>		4 Machinehours
"	11 <sup>00</sup> 18 <sup>00</sup>	10.5		2.2	1.8					10 <sup>00</sup> 17 <sup>00</sup> 14		Transp of growing equipment 2m
"										11 <sup>00</sup> 17 <sup>00</sup> 6.5		Transp of growing equipment 1m
25/10	7 <sup>00</sup> 15 <sup>00</sup>	5.1		15.6	15.1	3 <sup>00</sup> 14	10.7					
26/10	7 <sup>00</sup> 10 <sup>00</sup>				12.3	15.0 0.9°		6				Mounting of head, 2m
27/10	7 <sup>00</sup> 17 <sup>00</sup>							30				Backfill plane levelling 3m Transport by lorry 1.8 km

Table A4.13 Drilling report hole IC2(3)

PROJECT: Norwegian Seismic System Drilling Machine: Perfo 66															INSPECTOR: Raaen-Rugaas		Side 1			
SITE: By Asta															DRILLING FOREMAN: Selvik					
BOREHOLE NO: 1C3(19)																				
DATE	START/STOP TIME	ROCK DRILLING		OVER BURDEN DRILLING		GR W LEVEL		INCLINATION		GROUTING		WELDING		MOUNTING HOURS	BACKFILL HOURS	TRANSPORT		DELAY HOURS	ROCK DESCRIPTION	REMARKS
		DRILLED M DEPTH - M	CASING M	DEPTH - M	CASING M	DEPTH - M	CASING M	ANGLE	M	QTY	M	FROM	TO							
23/6																7:00	8:00	22		Transp of drilling equipm, 2m
"																7:00	18:00			11 Machine hours
24/6																7:00	17:50	16	Dark Spargomite	Drilling, 2m
"																7:00	17:30			10.5 Machine hours
25/6																7:00	17:00	20	Penetration rate 2.5 m/hour	Drilling, 2m
"																7:00	17:00			10 Machine hours
24/6																7:00	17:00	20		Tractor excavating, 2m
"																7:20	17:00			10 Machine hours
27/6																7:00	17:00	20		Digging, 2m
"																7:00	17:00			10 Machine hours
3/6																7:00	16:00	18		Water pumping, 2m
1/6																7:00	17:00			10 Machine hours
"																7:00	17:00	40		Transp and digging, 4m
2/6																7:00	17:00			10 Machine hours
"																7:00	17:00	20		Digging and pumping, 2m
3/6																7:00	17:00			10 Machine hours
"																7:00	17:00	30		Casing, 3m
4/6																7:00	16:30		20.5	Waiting for tractor, 3m
"																7:00	16:30			9.5 Machine hours
5/6																8:00	15:00	21		Transport, 3m
"																8:00	15:00			7 Machine hours
6/6																7:00	17:00	21		Transport, 2m
"																7:00	17:30			10.5 Machine hours

Table A4.14 Drilling report hole 1C3(19), page 1

PROJECT: *Norwegian Seismic System*    DRILLING MACHINE: *Pertb 66*    INSPECTOR: *Rosen-Rugeas*    Side 2  
 SITE: *By Asta*    DIAMETER: *158 mm*    DRILLING FOREMAN: *Seivik*  
 BOREHOLE NO: *1C3(19)*

DATE	START/STOP TIME	ROCK DRILLING DEPTH M	OVER-BURDEN DRILLING DEPTH M	CASING DEPTH M	GR LEVEL INCLINATION ANGLE IN	BROUTING (DIP) IN	WELDING (DIP) IN	MOUNTING HOURS	BACKFILL HOURS	TRANSPORT FROM TO HOURS	DELAY HOURS	WORK DESCRIPTION	REMARKS
7/11	7:00-17:00	105			43	130 06°				13:00-16:00	7		Transp of pipes, 2m
8/11	7:00-10:00	50		1533			1042	9		14:00-17:00			Dark sparagmite Mounting, 3m
19/11						31				11:00-17:00	12		Transport, 2m Lorie 36 km
						40				7:00-17:00			10 Machine hours
15/11										11:00-17:00	10		Penetration rate 2.5 m/min
										14:00-17:00	6		Transport, 3m
										7:00-17:00			-----, 2m
										7:00-17:00			10 Machine hours
										11:00-14:00	6		Plane leveling, 2m
4/11										7:00-11:00	9		Transp by lorie 36km, 2m

Table A4.15 Drilling report hole 1C3(19), page 2

PROJECT: <i>Norwegian Seismic System Phase I</i> SITE: <i>By Bremila</i> BOREHOLE NO: <i>1D1 (17)</i>														
INSPECTOR: <i>Rugaas-Raaen</i> DRILLING FOREMAN: <i>Selvik</i>														
DRILLING MACHINE: <i>H S 5</i> DIAMETER: <i>158 mm</i>														
DATE	START/STOP TIME	ROCK DRILLING DEPTH - M	OVER-BURDEN DEPTH - M	DRILLED DEPTH - M	DRILLING DEPTH - M	GRW LEVEL	INCLINATION	GROUTING	WELDING	MOUNTING	BACKFILL	TRANSPORT	DELAY	REMARKS
							ANGLE	Q/M	M	HOURS	HOURS	FROM TO	HOURS	
29/6													4	Waiting time, 2m, 2h
"												9 <sup>00</sup> 20 <sup>00</sup>	21	Transp of drilling equipment 2m
"												7 <sup>00</sup> 19 <sup>00</sup>		12 Machine hours
29/6												7 <sup>00</sup> 12 <sup>15</sup>	10	Transp of drilling equipment 2m
"												7 <sup>00</sup> 12 <sup>30</sup>		55 Machine hours
27/6	13 <sup>00</sup> 18 <sup>45</sup>	50												
29/6	9 <sup>00</sup> 12 <sup>00</sup>	122	18	12	20	45°								
"	12 <sup>00</sup> 14 <sup>00</sup>													
1/10												11 <sup>00</sup> 13 <sup>00</sup>	6	Washing the hole
"	13 <sup>00</sup> 18 <sup>00</sup>							28	63%					Transp of grouting equipment 3m
2/10												7 <sup>00</sup> 9 <sup>00</sup>	5	2 m
22/10	8 <sup>30</sup> 10 <sup>00</sup>									3				2 m (Mounting, backfilling)
"	13 <sup>30</sup> 16 <sup>00</sup>									3	45			3 m (and plane leveling)
														Transport by lorry
														48 + 97 = 145 km

Table A4.16 Drilling report hole 1D1(17)

PROJECT: Norwegian Seismic System Phase I SITE: By Grava BUREHOLE: NO 102 (18)														INSPECTOR: Rugaas-Raaen DRILLING FOREMAN: Selvik JF			
DRILLING MACHINE: Perfo 66 DIAMETER: 158 mm																	
DATE	START TIME	STOP TIME	ROCK DRILLING DEPTH IN CASING	OVER BURDEN DEPTH IN DRILLED HOLE	DRILLING DEPTH IN CASING	DRILLING DEPTH IN CASING	DRILLING DEPTH IN CASING	DRILLING DEPTH IN CASING	DRILLING DEPTH IN CASING	DRILLING DEPTH IN CASING	DRILLING DEPTH IN CASING	DRILLING DEPTH IN CASING	DRILLING DEPTH IN CASING	DRILLING DEPTH IN CASING	REMARKS		
27/3															Transp of drilling equip ment. 2m		
"															Transp of drilling equip 5m		
28/3															Transp. of drilling equip 2m		
"															18 Machine hours		
27-28/3															Penetration 17.5 1.0 M/hour		
29/3	11:30	10:30	65	65													
30/3	11:00	17:30	30	95													
2/10	10:00	16:30	30	125													
3/10	13:00	18:00	25	150	4420	0.5	0.5	45°	10°								
2/10										3/10 10.59							
22/10	8:30	16:00												5	175		
															Mounting, backfilling and plane levelling. 3M		
															Transport by lorry 12.8 * 11.8 = 242 km		

Table A4.17 Drilling report hole 1D2(18)



PROJECT: <i>Norwegian Seismic System Phase I</i> DRILLING MACHINE: <i>H.S. 5</i> INSPECTOR: <i>Rugaas-Raaen</i>														
SITE: <i>By Sjøsetra</i> DIAMETER: <i>158 mm</i> DRILLING FOREMAN: <i>Selvik jr</i>														
BOREHOLE NO: <i>1D3 (16)</i>														
DATE	START TIME	STOP TIME	ROCK DRILLING DEPTH-M	OVER-BURDEN DRILLED-M	DRILLING DEPTH-M	CASING DEPTH-M	GRouting DEPTH-M	INCLINATION ANGLE-M	WELDING FT	MOUNTING HOURS	BACKFILL HOURS	TRANSPORT FROM TO HOURS	DELAY HOURS	REMARKS
29%												14 <sup>00</sup> 19 <sup>00</sup>	10	Transp of drilling equipment 2m
"												14 <sup>00</sup> 19 <sup>00</sup>		5 Machine hours
2%												7 <sup>00</sup> 11 <sup>00</sup>	8	Dark sparagomite Tractor transp 2m
"												7 <sup>00</sup> 11 <sup>00</sup>		4 Machine hours
5%	9 <sup>00</sup>	17 <sup>30</sup>	110											
1/10	10 <sup>00</sup>	17 <sup>00</sup>	40	150	1430	275	190	0.4	145°					Penetration rate 1/65 m/min
19/10												7 <sup>00</sup> 8 <sup>00</sup>	3	3 m
"												17 <sup>00</sup> 18 <sup>00</sup>	3	Travelling time
"	8 <sup>00</sup>	17 <sup>00</sup>							3/10.55			7 <sup>00</sup> 8 <sup>00</sup>	5	5m
19/10												16 <sup>00</sup> 17 <sup>00</sup>	5	Travelling time
"	8 <sup>00</sup>	16 <sup>00</sup>								15	25			Mounting, welding and especially digging and backfilling, 5m
														Lonic transport 2x/106 = 212 km

Table A4.18 Drilling report hole 1D3(16)

PROJECT: Norwegian Seismic System DRILLING MACHINE: *Perb 66*  
 SITE: *By Høyisen* DIAMETER: *150 mm*  
 BOREHOLE NO: *1E1 (14)*  
 INSPECTOR: *Rugaas*  
 DRILLING FOREMAN: *Selvik jr*

DATE	START/STOP TIME	ROCK DRILLING DEPTH - M	DYER-BURDEN DRILLED - M	DRILLING DEPTH - M	CASING DEPTH - M	DRILLING DEPTH - M	INCLINATION ANGLE - °	GROUTING QUANTITY - M³	WELDING METERS	LOADING HOURS	BACKFILL HOURS	TRANSPORT FROM TO HOURS	DELAY HOURS	ROCK DESCRIPTION	REMARKS
1/10												7 <sup>00</sup> 17 <sup>00</sup>	19	Dark sandstone	Transp of drilling equipment from 102 (10) to 1E1(14), 4 m
5/10												7 <sup>00</sup> 18 <sup>00</sup>	21	Penetration rate 2.5 m/hour	
7/10	9 <sup>00</sup> 6 <sup>00</sup>	50													
9/10	9 <sup>00</sup> 15 <sup>00</sup>	102	1.5			1.5	45°/75°								
1/10												7 <sup>00</sup> 17 <sup>00</sup>			9.5 Machine hours
5/10												7 <sup>00</sup> 18 <sup>00</sup>			10.5 Machine hours
27/10												10 <sup>00</sup> 17 <sup>00</sup>	28		Transp of pipes, 4 m
29/10								31				7 <sup>00</sup> 10 <sup>00</sup>	9		Grouting, 3 m
29/10								1.20				8 <sup>00</sup> 9 <sup>00</sup>	2		---, 2 m
.										6		9 <sup>00</sup> 12 <sup>00</sup>			Mounting, 2 m
30/10												12 <sup>00</sup> 13 <sup>00</sup>	2		Transport, 2 m
											15	7 <sup>00</sup> 12 <sup>00</sup>			Plane levelling, 3 m
															Lorrie transport 43.58-58-60 km

Table A4.19 Drilling report hole 1E1(14)

DATE	START TIME	STOP TIME	ROCK DRILLING SPILLED DEPTH-M	CASING-M	OVER-BURDEN DRILLED-DEPTH-M	DRILLING DEPTH-M	DRILLING CASPING-M	DEPTH-M	UPPER LEVEL DEPTH-M	INCLINATION - M	GROUTING ANGLE (M)	WELDING (M)	MOUNTING HOURS	BACKFILL HOURS	TRANSPORT FROM TO HOURS	DELAY HOURS	ROCK DESCRIPTION	REMARKS
9/11															15:30 17:00	3		Transport, 2 m
"															15:30 17:00			15 Machine hours
9/11															7:00 17:00			10
"															7:00 17:00	20		Waiting for tractor, 2 m

PROJECT: Norwegian Seismic System Phase I  
 SITE: By Vestesætra  
 BOREHOLE NO: 1E2 (15)

INSPECTOR: Kåren - Rygeas  
 DRILLING FOREMAN: Selvik

Order to stop 15/11-67

Table A4.20 Drilling report hole 1E2(15)

PROJECT: Norwegian Seismic System DRILLING MACHINE: Perfo 66													INSPECTOR: Raaen - Rugaas		Side /			
SITE: By Svartåsen													DRILLING FOREMAN: Selvik					
BOREHOLE NO: 1E3 (13)																		
DATE	START TIME	STOP TIME	ROCK DRILLING DEPTH - M	DRILLED DEPTH - M	CASING DEPTH - M	OVER-BURDEN DRILLED DEPTH - M	DRILLING DEPTH - M	CASING DEPTH - M	GRouting	WELDING	HOISTING	BACKFILL	TRANSPORT FROM TO	DELAY HOURS	ROCK DESCRIPTION	REMARKS		
8/10													13 <sup>30</sup> 15 <sup>30</sup>	4		Transp. from 1E1 (14) to road, 2 m		
"													13 <sup>30</sup> 15 <sup>30</sup>			2 Machine hours		
9/10													7 <sup>00</sup> 13 <sup>00</sup>	12		Transp. by car, 2 m, +3 km		
"													7 <sup>00</sup> 15 <sup>00</sup>			6 Machine hours		
9/10													4 <sup>30</sup> 18 <sup>30</sup>	10.5		Transp. from road to 1E3 (13), 3 m		
"													4 <sup>30</sup> 18 <sup>30</sup>			4 Machine hours		
9/10													7 <sup>00</sup> 17 <sup>00</sup>	20		Rearrangement of rig 2 m		
"																		
"													17 <sup>00</sup> 19 <sup>00</sup>	6		12 Machine hours		
"													7 <sup>00</sup> 19 <sup>00</sup>			12		
17/10													7 <sup>00</sup> 19 <sup>00</sup>			12		
18/10													7 <sup>00</sup> 19 <sup>00</sup>			12		
19/10													7 <sup>00</sup> 19 <sup>00</sup>			12		
20/10													7 <sup>00</sup> 19 <sup>00</sup>			12		
21/10													7 <sup>00</sup> 14 <sup>00</sup>			7		
22/10													7 <sup>00</sup> 14 <sup>00</sup>			7		
9/11													4 <sup>30</sup> 17 <sup>30</sup>	9		Digging and pumping, 3 m		
7/11													11 <sup>00</sup> 13 <sup>00</sup>	4		Transp. of pipes, 2 m		
8/11													7 <sup>00</sup> 17 <sup>00</sup>	30		Transp. of driving equipment, 3 m		
"													12 <sup>00</sup> 17 <sup>00</sup>	10		— 2 m		
"													7 <sup>00</sup> 17 <sup>00</sup>			10 Machine hours		
"																9/11 Lorry transp. 84 km		
9/11													7 <sup>00</sup> 16 <sup>00</sup>	30		Transport, 6 m		

Table A4. 21 Drilling report hole 1E3(13), page 1

PROJECT: Norwegian Seismic System Drilling Machine: Perfo 66														INSPECTOR: Raagen - Rugaas		Side 2					
SITE: By Svartåsen														DRILLING FOREMAN: Selvik							
BOREHOLE NO: 1E3 (13)																					
DATE	START/STOP TIME	ROCK DRILLING DEPTH IN CASING - M	OVER-BURDEN DRILLING DEPTH IN CASING - M	GR W LEVEL DEPTH - M	INCLINATION ANGLE IN °	GROUTING QTY	WELDING FT	MOUNTING HOURS	BACK-FILL HOURS	TRANSPORT FROM TO HOURS	DELAY HOURS	WORK DESCRIPTION	REMARKS								
9/11										7 <sup>00</sup> 12 <sup>00</sup>			5 Machine hours								
"	12 <sup>00</sup> 15 <sup>00</sup>	1560	1560	1477	11°	31						No Drilling problems									
13/11						+40															
14/11								8	4	11 <sup>00</sup> 16 <sup>00</sup> 20			Transport, 4 m								
"										13 <sup>00</sup> 17 <sup>00</sup>			Mounting backfilling 3m								
"										0 <sup>00</sup> 11 <sup>00</sup> 6			Transport by Arnie 32 kWh, 2 m								

Table A4.22 Drilling report hole 1E3(13), page 2

PROJECT: *Norwegian Seismic System Phase I*     DRILLING MACHINE: *H S 5*     INSPECTOR: *Raen*  
 SITE: *By Kerten*     DIAMETER: *150 mm*     DRILLING FOREMAN: *Selvik jr.*  
 BOREHOLE NO: *1F1(11)*

DATE	START/STOP TIME	ROCK DRILLING DEPTH IN CASING - m	OVER-BURDEN DRILLING DEPTH - m	DRILLED DEPTH - m	DRILLING DEPTH IN CASING - m	DRILLING DEPTH - m	GR W LEVEL	INCLINATION	BRIDGING	WELDING	HOISTING	BACKFILL	TRANSPORT	DELAY	WORK DESCRIPTION	REMARKS
												HOURS	FROM TO HOURS	HOURS		
17/10													6 <sup>00</sup> 19 <sup>00</sup>	6		Transp of chiling equip - med. 2 m
"													6 <sup>00</sup> 19 <sup>00</sup>			3 Machine hours
18/10													7 <sup>00</sup> 19 <sup>00</sup>	14	Mixed	Transp of chiling equip - med. 2 m
"													7 <sup>00</sup> 19 <sup>00</sup>			12 Machine hours
19/10	7 <sup>00</sup> 16 <sup>00</sup>	120	120													
20/10	7 <sup>00</sup> 14 <sup>00</sup>	315	1515	1420	08	10	33	45	12°							Penetration rate 15 m
21/10													10 <sup>00</sup> 15 <sup>00</sup>	9		Transp of greasing equipment 3 m
24/10													13 <sup>00</sup> 15 <sup>00</sup>	5		Rigging 2 m
25/10	7 <sup>00</sup> 14 <sup>00</sup>								31	1072						
"	14 <sup>00</sup> 17 <sup>00</sup>								24		9					3 m
27/10	7 <sup>00</sup> 10 <sup>00</sup>													9		3 m

Table A4.23 Drilling report hole 1F1(11)

PROJECT: Norwegian Seismic System DRILLING MACHINE: H.S 5  
 SITE: By Steinsætra DIAMETER: 150 mm  
 BOREHOLE NO: 1F2 (12)

INSPECTOR: Rugaas - Raalen  
 DRILLING FOREMAN: Selvik Jr.

DATE	START/STOP TIME	ROCK DRILLING		OVER-BURDEN DRILLING		GROUTING DEPTH - M	INCLINATION ANGLE - °	WELDING	MOUNTING HOURS	BACKFILL HOURS	TRANSPORT		DELAY HOURS	REMARKS
		DRILLED DEPTH - M	LOSS DEPTH - M	DRILLED DEPTH - M	LOSS DEPTH - M						FROM	TO		
2/10												7 <sup>00</sup> 15 <sup>00</sup>	6	Transp from 103 (16) to road, 2 m
"												7 <sup>00</sup> 18 <sup>00</sup>		11 Machine hours
"												15 <sup>00</sup> 18 <sup>00</sup>	6	Transp from road to 1F2 (12), 2 m
														Penetration rate: 3.0 %
24/10												7 <sup>00</sup> 17 <sup>30</sup>	21	Transp of drilling equip from 103 (16) to 1F2 (12), 2 m
"												13 <sup>00</sup> 17 <sup>00</sup>	8	
"												7 <sup>00</sup> 17 <sup>30</sup>		10.5 Machine hours
27/10	7 <sup>00</sup> 17 <sup>00</sup>	155	155	415	225	125	135	15.0 06°						
31/10								81 20	10.30	12		12 <sup>00</sup> 16 <sup>00</sup>		Grouting, 3 m
"										9		13 <sup>00</sup> 16 <sup>00</sup>		Plane leveling and mounting, 3 m
														Lorrie Transport 107 = 10 = 125 km

The equipment was now moved to 102 (16) because of convenience of helicopter transport

Table A4. 24 Drilling report hole 1F2(12)

PROJECT: Norwegian Seismic System Phase I														INSPECTOR: Ruggaas						
DRILLING MACHINE: HS 5														DRILLING FOREMAN: Selvik						
SITE: By Sjøda																				
BOREHOLE NO: 1F3(10)																				
DATE	START TIME	STOP TIME	ROCK DRILLING DEPTH - M	OVER-BURDEN DEPTH - M	DRILLING DEPTH - M	OVER-BURDEN DEPTH - M	DRILLING DEPTH - M	OVER-BURDEN DEPTH - M	DRILLING DEPTH - M	OVER-BURDEN DEPTH - M	DRILLING DEPTH - M	OVER-BURDEN DEPTH - M	DRILLING DEPTH - M	OVER-BURDEN DEPTH - M	WELDING M	MOUNTING HOURS	BACKFILL HOURS	TRANSPORT FROM TO HOURS	DELAY HOURS	REMARKS
28/10																		7 <sup>00</sup> 17 <sup>00</sup>		10 Machine hours
"																		7 <sup>00</sup> 10 <sup>00</sup>	6	Waiting for tractor, 2m
"																		10 <sup>00</sup> 13 <sup>00</sup>	6	Transport, 2m
29/10																		8 <sup>00</sup> 15 <sup>00</sup>		7 Machine hours
"																		13 <sup>00</sup> 15 <sup>00</sup>	4	Transport, 2m
"																		7 <sup>00</sup> 17 <sup>00</sup>	30	Dark storage site
30/10																		7 <sup>00</sup> 17 <sup>00</sup>		Transport and digging by hand, 3m
"																		7 <sup>00</sup> 17 <sup>00</sup>		10 Machine hours
31/10																		7 <sup>00</sup> 16 <sup>00</sup>		9
"																		7 <sup>00</sup> 16 <sup>00</sup>	27	Transp by lorry, 3m, 62km
"																				
"	16 <sup>00</sup>	17 <sup>00</sup>	05	05																
1/11	7 <sup>00</sup>	17 <sup>00</sup>	153	158	153.33	0.25	105	130	09	44.5	125							7 <sup>00</sup> 0 <sup>00</sup>	4	Transport, 4m
2/11																		8 <sup>00</sup> 13 <sup>00</sup>	5	Mounting of pipes
"															10.3	5	5	13 <sup>00</sup> 15 <sup>00</sup>		Mounting and plane levelling, 4m
"																		15 <sup>00</sup> 17 <sup>00</sup>	10	Transport in return by hand 6.5 km, 4m
"																				
"																				
"																				
"																				
"																				

Table A4.25 Drilling report hole 1F3(10)



PROJECT: <i>Norwegian Seismic System Phase I</i> INSPECTOR: <i>Rugaas-Raaen</i> Side / SITE: <i>By Brekkalen</i> DIAMETER: <i>158 mm</i> DRILLING FOREMAN: <i>Selvik Jr</i> BOREHOLE NO: <i>1F4 (20)</i>															
DATE	START/STOP TIME	ROCK DRILLING DRILLED DEPTH - m	CASING DEPTH - m	OVER-BURDEN DRILLED DEPTH - m	CASING DEPTH - m	GR W/LEVEL DEPTH - m	INCLINATION ANGLE °	GRROUTING GTT	WELDING m	MOUNTING HOURS	BACKFILL HOURS	TRANSPORT FROM TO HOURS	DELAY HOURS	ROCK DESCRIPTION	REMARKS
8/10												10 <sup>00</sup> 15 <sup>00</sup>			5 Machine hours
"												10 <sup>00</sup> 15 <sup>00</sup>	10		Transp, 2 m No Larve 15 mm
8/10												7 <sup>00</sup> 18 <sup>00</sup>			11 Machine hours
"												7 <sup>00</sup> 18 <sup>00</sup>	21		Transport, 2 m
8/10												7 <sup>00</sup> 18 <sup>00</sup>			10.5 Machine hours
"												7 <sup>00</sup> 18 <sup>00</sup>	21		Transport, 2 m
8/10												7 <sup>00</sup> 18 <sup>00</sup>			10.5 Machine hours
"	7 <sup>00</sup> 17 <sup>00</sup>														10.5 h over-burden drilling
8/10	7 <sup>00</sup> 17 <sup>00</sup>														10.5 Machine hours
"												7 <sup>00</sup> 17 <sup>00</sup>			10.5 h over-burden drilling
8/10	7 <sup>00</sup> 17 <sup>00</sup>											7 <sup>00</sup> 17 <sup>00</sup>			9.5 h Machine hours
"												7 <sup>00</sup> 17 <sup>00</sup>			9.5 h over-burden drilling
8/10	7 <sup>00</sup> 18 <sup>00</sup>											7 <sup>00</sup> 18 <sup>00</sup>			10.5 Machine hours
"												7 <sup>00</sup> 18 <sup>00</sup>			10.5 h over-burden drilling
8/10	7 <sup>00</sup> 18 <sup>00</sup>											7 <sup>00</sup> 18 <sup>00</sup>			10.5 Machine hours
"												7 <sup>00</sup> 18 <sup>00</sup>			10.5 h over-burden drilling
8/10	7 <sup>00</sup> 18 <sup>00</sup>											7 <sup>00</sup> 18 <sup>00</sup>			10.5 Machine hours
"												7 <sup>00</sup> 18 <sup>00</sup>			10.5 h over-burden drilling
8/10	7 <sup>00</sup> 18 <sup>00</sup>											7 <sup>00</sup> 18 <sup>00</sup>			10.5 Machine hours
"												7 <sup>00</sup> 18 <sup>00</sup>			10.5 h over-burden drilling
8/10	7 <sup>00</sup> 18 <sup>00</sup>											7 <sup>00</sup> 18 <sup>00</sup>			10.5 Machine hours
"												7 <sup>00</sup> 18 <sup>00</sup>	21		Dismounting, 2 m
8/10	10 <sup>00</sup> 19 <sup>00</sup>											7 <sup>00</sup> 18 <sup>00</sup>			9 Machine hours

Table A4.26 Drilling report hole 1F4(20), page 1

PROJECT: Norwegian Seismic System Drilling Machine: Porto 66		INSPECTOR: Rypaas-Raaen		side 2					
SITE: By Breittablen		DRILLING FOREMAN: Selvik jr							
BOREHOLE NO: 1F4 (20)		DIAMETER: 150mm							
DATE	START/STOP TIME	ROCK DRILLING DEPTH - M	OVER-BURDEN DRILLING DEPTH - M	GRouting (M)	WELDING (M)	HOISTING HOURS	BACKFILL HOURS	TRANSPORT TO/ FROM HOURS	REMARKS
4/6								10 <sup>00</sup> 17 <sup>00</sup>	Transfer of drilling equipment from (L1E) to road, 1 km
7/6	14 <sup>00</sup> 19 <sup>00</sup>							14 <sup>00</sup> 16 <sup>00</sup>	5 Machine hours
"								14 <sup>00</sup> 16 <sup>00</sup>	Transfer of drilling equipment along road, 1 km
"								16 <sup>00</sup> 19 <sup>00</sup>	Transfer of drilling equipment 2 m
4/6								7 <sup>00</sup> 17 <sup>00</sup>	Dark springsuit until 15m.
"								7 <sup>00</sup> 17 <sup>00</sup>	Attempt at chiling, 2 m
"								7 <sup>00</sup> 17 <sup>00</sup>	Further down hole springsuit
5/6								7 <sup>00</sup> 17 <sup>00</sup>	10 Machine hours
5/6								7 <sup>00</sup> 17 <sup>00</sup>	Waiting for tractor, 2 m
5/6								7 <sup>00</sup> 18 <sup>00</sup>	11 Machine hours
5/6								7 <sup>00</sup> 18 <sup>00</sup> 22	Transfer and digging, 2 m
5/6								7 <sup>00</sup> 18 <sup>00</sup>	11 Machine hours
5/6								7 <sup>00</sup> 18 <sup>00</sup> 22	Churn drilling continues, 2 m
5/6								7 <sup>00</sup> 18 <sup>00</sup>	11 Machine hours
5/6								7 <sup>00</sup> 18 <sup>00</sup> 22	Churn drilling continues, 2 m
5/6								7 <sup>00</sup> 18 <sup>00</sup>	11 Machine hours
5/6								7 <sup>00</sup> 11 <sup>00</sup> 16	Transfer of Porto from (L370) to (L320), 4 km
5/6								8 <sup>00</sup> 16 <sup>00</sup> 15	5 m
"								7 <sup>00</sup> 16 <sup>00</sup>	9 Machine hours
"								7 <sup>00</sup> 18 <sup>00</sup> 22	Leave transfer, 40 km
"								7 <sup>00</sup> 18 <sup>00</sup> 22	Drilling and grouting, 2 m
5/6	7 <sup>00</sup> 17 <sup>00</sup>	12.5							
5/6	7 <sup>00</sup> 12 <sup>00</sup>	3	15.5	14.04	9.2	9.2	0.4	50	12°
4/6								10.55	
7/6									
								17 <sup>00</sup> 15 <sup>00</sup> 6	Transfer of pipes and grout equipment, 2 m
									3 m
									Returning equipment, 3 m

Table A4.27 Drilling report hole 1F4(20), page 2

A4.3 Mortar-sand testing report

**NORCONSULT A.S.** Examination of Aggregate

CONSULTING ENGINEERS, ARCHITECTS & ECONOMISTS

Sarbuvollveien 13, Hovik  
 Postal address: P.O. Box 177 - HOVIK - Norway  
 Telephone: Oslo 53 00 00 - Telegrams: Norconsult Oslo

Customer:	NDRE, Kjeller	
Project:	Seismic Station, Øyer	
Aggregate:	Sand for mortar in drillholes	Quantity: 1 kg
Sample taken:	Project site	Date: Sept 22 1967

Humus test, color:	0 - 0.5	Remarks: Satisfactory
Mud volume %:	2.3	Remarks: " "
Specific weight:	2.66 kg/dm <sup>3</sup>	Remarks: Normal

Sieve analysis

Mesh width (mm)	0.15	0.30	0.60	1.20	2.40	4.80	9.60	19.0	38.0	FM
% retained	95.4	63.6	20.0	7.5	2.4	1.0	0	0	0	1.90

Remarks: Sand of satisfactory quality.

Oslo, Sept 28 1967

Figure A4.1 Consultants report on sand for cementing mortar casing

A4.4 Mortar specifications (original in Norwegian)

The composition of the mortar to be used for cementing the casing tubes in the boreholes at Øyer is as follows:

- Cement: a) Belgian sulphate-resistant cement.  
Agent: A/S Stormbull
- b) Danish sulphate-resistant cement corresponding to US cement type V.  
Agent: Norsk Portland Cementkontor A/S

Sand: Fine

Proportions: 1 part cement - 1.5 part sand

Consistency: Thin pouring - slump approx 15 cm

It is assumed that injection tubes down to the bottom of the holes will be used to displace ground water present.

A4.5 Control of welding and pressuretesting of casings in drillholes

Control in connection with the welding and pressuretesting of the casings in drill holes at the Seismic Station, Øyer:

- Forge scales to be removed from all welds.
- Welds and areas burned and scraped off to be covered by 2 coats of "Corroless" non-corrosive paint.
- Casings to be controlled with a template for possible welding grades.
- Casings to be covered by oil at the point of welding after the welding is finished.
- Casings to be pressure tested at  $6 \text{ kg/cm}^2$ , and the welds visually inspected (soap foam) for possible leakage before being placed in the drillholes.
- When in place, the casings to be checked for tightness with airpressure at  $6 \text{ kg/cm}^2$ , and control of stable pressure to be kept for 30 minutes.
- The position of the welds in the drillholes to be registered.

APPENDIX 5

SOME DATA CONCERNING THE POWER SUPPLY AT ØYER

The power connection consists of termination equipment at the Moksa power plant at Tretten, a high tension (10 kV) pole line from the plant to the timber-line near Vetlsetra, a 10 kV earth cable from there to the transformer hut, and finally a short 220 V earth cable connection to the DRC hut.

A5.1 Terminal at the power plant

The termination equipment comprises a power switch, two disconnecting switches and a cabinet with ampere-, volt-, kWh-meters and controls for the power switches. The switches are installed in two cells, one containing a disconnecting switch and transformers for measuring current and voltage, the other the power switch and the remaining disconnecting switch.

A5.2 Wires and cables

- a) The pole line uses steel-aluminium conductors, type SAHF No 16 (equivalent to 16 sq mm Cu), mounted on single wooden poles. Terminating poles and poles introducing angles on the line are double, so-called H-masts.
- b) High tension earth cable: Type NKBA, 11 kV, 3 x 10 sq mm Cu.
- c) Low tension earth cable: Type PFSP, 3 x 50 sq mm Cu.

A5.3 Transformer hut

The hut has three cells, containing respectively:

- a) A transformer, 10 kV  $\pm$  5%/230 V, 50 kVA
- b) High tension switches
- c) Low tension fuses and measuring equipment

The transformer hut is produced and delivered by Norsk Elektrisk & Brown Boveri, Oslo.

**DOCUMENT CONTROL DATA R&D**

(Security classification of title, body of abstract and indexing annotation must be entered when the overall report is classified)

1 ORIGINATING ACTIVITY (Corporate author) Norwegian Defence Research Establishment Kjeller, Norway		2a REPORT SECURITY CLASSIFICATION <b>UNCLASSIFIED</b>	
		2b GROUP	
3 REPORT TITLE NORSAR (Norwegian seismic array), Phase 1 (Installation)			
4 DESCRIPTIVE NOTES (Type of report and inclusive dates) Technical report, final			
5 AUTHOR(S) (Last name, first name, initial) None			
6 REPORT DATE October 1968	7a TOTAL NO OF PAGES 137	7b NO OF REFS 0	
8a CONTRACT OR GRANT NO F 61052-68-C-0009	9a ORIGINATOR'S REPORT NUMBER(S) IR-S-37		
b PROJECT NO	9b OTHER REPORT NO(S) (Any other numbers that may be assigned this report)		
c			
d			
10 AVAILABILITY/LIMITATION NOTICES Copies of this report may be obtained from DDC by qualified requesters			
11 SUPPLEMENTARY NOTES		12 SPONSORING MILITARY ACTIVITY Hq Electronic Systems Division, AFSC, USAF L G Hanscom Field, Bedford, Mass	
13 ABSTRACT This report concerns installation of Phase 1 of a large aperture seismic array (NORSAR) being built in south-eastern Norway. Phase 1 comprises a 12 short period (SP) seismometers subarray at Øyer near the town of Lillehammer, a 5 - 7 SP sensors experimental noise study array at Falldalen, E of Lake Mjøsa, and a rudimentary long period (LP) array consisting of 3 three-component LP sensors located at Øyer, Falldalen and Borgseter, the latter point situated about 20 km from the Swedish border.  The data handling system consists of 5 recording units, one each for the two SP arrays and the three LP installations. The units have a multiplexer for sampling of sensor analog signals, an analog/digital converter and a magnetic tape station for recording of digital codes for identification, time-of-day and sensor signals. Drilling and casing of some 20 boreholes in bedrock, trenching and laying of about 60 km of cables and building of four underground vaults were the main constructional tasks of the Phase 1 project.  Subsequent to a brief pre-history of NORSAR, Phase 1, the report describes the planning and implementation stages and presents the technical data of the project.			

UNCLASSIFIED

KEY WORDS

NORSAR - Norwegian Seismic Array  
Norway - Large Aperture Seismic Array  
Large Aperture Seismic Array  
Seismic Array  
Seismic Signals Recording  
Seismic Noise Study

UNCLASSIFIED