

AD 688079

MISCELLANEOUS PAPER S-69-15

**EVALUATION OF NUCLEAR METHODS OF
DETERMINING SURFACE IN SITU SOIL
WATER CONTENT AND DENSITY**

by

**T. B. Rosser III
S. L. Webster**



April 1969

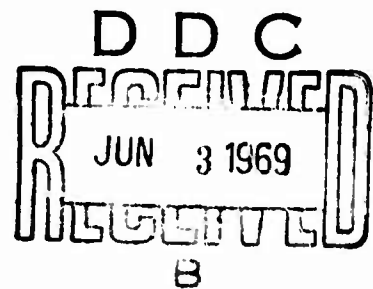

Sponsored by

**Office, Chief of Engineers
U. S. Army**

Conducted by

**U. S. Army Engineer Waterways Experiment Station
CORPS OF ENGINEERS
Vicksburg, Mississippi**

**THIS DOCUMENT HAS BEEN APPROVED FOR PUBLIC RELEASE
AND SALE; ITS DISTRIBUTION IS UNLIMITED**

Reproduced by the
CLEARINGHOUSE
for Federal Scientific & Technical
Information Springfield Va. 22151

Destroy this report when no longer needed. Do not return
it to the originator.

ACCESSION for	
CFSTI	WHITE SECTION <input checked="" type="checkbox"/>
DDC	DDFF SECTION <input checked="" type="checkbox"/>
UNANNOUNCED	<input type="checkbox"/>
JUSTIFICATION	
BY	
DISTRIBUTION/AVAILABILITY CODE	
DIST.	AVAIL. AND/OR

The findings in this report are not to be construed as an official
Department of the Army position unless so designated
by other authorized documents.

AD 688079

MISCELLANEOUS PAPER S-69-15

**EVALUATION OF NUCLEAR METHODS OF
DETERMINING SURFACE IN SITU SOIL
WATER CONTENT AND DENSITY**

by

**T. B. Rosser III
S. L. Webster**



April 1969

Sponsored by

**Office, Chief of Engineers
U. S. Army
Project No. 4A024401A891**

Conducted by

**U. S. Army Engineer Waterways Experiment Station
CORPS OF ENGINEERS
Vicksburg, Mississippi**

ARMY-MRC VICKSBURG, MISS.

**THIS DOCUMENT HAS BEEN APPROVED FOR PUBLIC RELEASE
AND SALE; ITS DISTRIBUTION IS UNLIMITED**

THE CONTENTS OF THIS REPORT ARE NOT TO
BE USED FOR ADVERTISING, PUBLICATION, OR
PROMOTIONAL PURPOSES. CITATION OF TRADE
NAMES DOES NOT CONSTITUTE AN OFFICIAL
ENDORSEMENT OR APPROVAL OF THE USE OF
SUCH COMMERCIAL PRODUCTS.

FOREWORD

The investigation reported herein was conducted by the Flexible Pavement Branch, Soils Division, U. S. Army Engineer Waterways Experiment Station (WES), under the sponsorship of the Advanced Technology Branch, Engineering Division, Military Construction, Office, Chief of Engineers. The work described was accomplished in accordance with "Permanent Construction Materials Research, FY 1967-68," under DA Project No. 4A024401A891. This report presents the results of an investigation conducted during the period November 1967-April 1968 to evaluate nuclear methods for determining surface in situ soil water contents and densities.

Engineers of the Soils Division, WES, who were actively engaged in the planning, testing, analyzing, and reporting phases of the investigation were Messrs. R. G. Ahlvin, A. H. Joseph, P. J. Vedros, Jr., S. L. Webster, and T. B. Rosser III. The work was conducted under the general supervision of Messrs. W. J. Turnbull and A. A. Maxwell, Chief and Assistant Chief, respectively, of the Soils Division. This report was prepared by Messrs. Rosser and Webster.

COL John R. Oswald, Jr., CE, and COL Levi A. Brown, CE, were Directors of the WES during the conduct of the investigation and the preparation of this report. Messrs. J. B. Tiffany and F. R. Brown were Technical Directors.

CONTENTS

	<u>Page</u>
FOREWORD	v
CONVERSION FACTORS, BRITISH TO METRIC UNITS OF MEASUREMENT	ix
SUMMARY	xi
INTRODUCTION, PURPOSE, AND SCOPE	1
Introduction	1
Purpose	1
Scope	1
THEORY OF USE OF NUCLEAR METHODS TO MEASURE SOIL DENSITY AND WATER CONTENT	1
Definitions of Pertinent Terms	1
Density Determination	2
Soil Water Content Measurements	2
DESCRIPTION OF EQUIPMENT AND TEST PROCEDURES	3
Equipment	3
General Laboratory Procedure	3
TEST DATA ANALYSIS	6
Density Determinations	6
Water Content Determinations	7
Radiation Dosage	7
DISCUSSION OF RESULTS	7
LITERATURE CITED	9
TABLES 1 and 2	
PLATES 1-16	
APPENDIX A: TEST PROCEDURE FOR DETERMINING SURFACE LAYER DENSITY AND WATER CONTENT OF SOIL BY NUCLEAR METHODS	A1

CONVERSION FACTORS, BRITISH TO METRIC UNITS OF MEASUREMENT

British units of measurement used in this report can be converted to metric units as follows:

<u>Multiply</u>	<u>By</u>	<u>To Obtain</u>
inches	2.54	centimeters
feet	0.3048	meters
cubic feet	0.0283168	cubic meters
pounds per cubic foot	16.0185	kilograms per cubic meter

SUMMARY

A laboratory investigation was conducted to evaluate the accuracy and reliability of measuring surface in situ soil water content and density by the backscatter and direct transmission nuclear methods. A single nuclear device and scaler were used in the laboratory tests. The nuclear device functioned as either a surface backscatter moisture and density meter or as a direct transmission density probe.

In order to determine the accuracy of the nuclear measurements, it was necessary to know the actual density and water content of the test soil. Boxes were fabricated to exact dimensions (2 ft by 2 ft by 9 in.), filled with uniformly compacted soil, and weighed, and the actual average soil density values were calculated.

Five soil types were selected for testing in order to approximate a full range of possible construction materials: heavy clay (CH), lean clay (CL), sand (SP), clayey gravelly sand (SP-SC), and a well-graded crushed limestone. Each of these soils was tested at eight different densities and water contents, resulting in a total of 40 samples. In order to obtain comparative results, soil densities of each sample were determined by two accepted conventional methods for determining density in the field, i.e. the sand-cone and water-balloon methods.

Test results indicated that in situ densities determined by the direct transmission nuclear method using the factory calibration curve furnished with the device were as accurate as the densities obtained by the sand-cone and water-balloon methods. The direct transmission nuclear method using a WES-developed calibration curve provided slightly more accurate density measurements than either the sand-cone or water-balloon method. Densities determined by the surface backscatter nuclear method using both the factory calibration curve and a WES-developed curve were not so accurate as densities obtained by the conventional methods.

Water contents were obtained by nuclear means and compared with actual water contents as determined from oven-dried samples from each box. Using a WES-developed calibration curve, water contents obtained by the nuclear method were sufficiently accurate for most quality control fieldwork (68 percent of the nuclear water contents were within ± 1.23 percent of the actual water contents, and 95 percent were within ± 2.46 percent). However, water contents obtained using the factory calibration curve could not be considered accurate enough for field use (68 percent of the nuclear water contents were within ± 3.81 percent of the actual water contents, and 95 percent were within ± 7.62 percent).

A test procedure for determining surface layer density and water content of soil by nuclear methods is presented in Appendix A.

BLANK PAGE

EVALUATION OF NUCLEAR METHODS OF DETERMINING SURFACE IN SITU SOIL WATER CONTENT AND DENSITY

INTRODUCTION, PURPOSE, AND SCOPE

Introduction

1. Considerable time is needed to determine in situ soil water content and density by present conventional methods. Therefore, in an attempt to expedite field tests and improve the methods of performing the tests, considerable research has been conducted since the early 1950's to develop methods and equipment for rapidly obtaining reliable moisture and density values.

Purpose

2. The purpose of the investigation reported herein was to evaluate the applicability of the nuclear moisture-density methods for field use by (a) determining the accuracy of the surface soil water contents and densities obtained through use of nuclear methods, and (b) comparing the results obtained by nuclear methods with those obtained by conventional methods.

Scope

3. This investigation was limited to a laboratory study using soil samples of known volume and weight, and, therefore, known average density. The laboratory study was necessary in order that nuclear method test densities could be compared with actual average densities rather than with conventional densities as would occur in a field study. Densities were obtained by conventional field methods for comparison with the nuclear densities.

4. Five types of locally available soil, selected to represent a wide range of construction material, were tested. These were heavy clay (CH), lean clay (CL), clayey gravelly sand (SP-SC), clean sand (SP), and well-graded crushed limestone. Classification data for each material are shown in plate 1. Each soil was tested at eight different density-moisture conditions.

THEORY OF USE OF NUCLEAR METHODS TO MEASURE SOIL DENSITY AND WATER CONTENT

Definitions of Pertinent Terms

5. For information and clarity, definitions of certain terms used in this report are given below:

Standard deviation. The square root of the mean of the squares of the individual deviations of the nuclear and/or conventional measurements from the actual measurements.

Average deviation. The average of the deviations of the nuclear and/or conventional measurements from the actual measurements.

Curie. Unit of quantity of radioactive material in which the number of disintegrations per second is 3.70×10^{10} .

Gamma radiation. Pure energy released in the natural decay of an unstable nucleus.

mev (million electron volts). Energy of radiation is expressed in units of electron volts (ev), which are small units of energy commonly used in nuclear physics. The ev is the energy (speed) that a unit-charged particle acquires when it falls through a potential of one volt; it is equivalent to

1.602×10^{-12} ergs, and $1 \text{ erg} = 2.78 \times 10^{-14}$ kwhr.

Nuclide. A species of atom characterized by the constitution of its nucleus, i.e., the number of protons and neutrons and energy content.

Optimum air gap. The air gap at which a maximum gauge reading is obtained.

Photon. A quantum of energy.

rad. A unit of absorbed dose of any type of radiation. One rad is the absorption of 100 ergs of energy per gram of absorber.

Radioactive nuclide. A nuclide whose atoms have unstable nuclei that attempt to reach a more stable (less energetic) state by releasing excess energy in the form of nuclear radiation.

rem (roentgen equivalent man). One rem is an absorbed dose of any ionizing radiation that will produce the same biological effect in man as the absorbed dose from exposure to one roentgen of X or gamma radiation.

rhm. Rads per hour at one meter.

Roentgen. Unit of exposure dose of X or gamma radiation.

Density Determination

6. The ability of a soil to absorb gamma radiation is directly proportional to the density of the soil. Gamma radiation is absorbed by three means, depending on the energy of the source: (a) photo electric effect (low gamma energies), (b) Compton effect (medium gamma energies), and (c) ionpair production (high gamma energies).

7. Instruments for measuring soil density are of two types: (a) the backscatter gauge, which measures gamma photons that have been scattered by Compton effect, and (b) the direct transmission gauge, which measures both gamma photons that are transmitted directly from the source without energy loss and those that have been scattered by Compton effect. With both types of gauges, the gamma counts are inversely proportional to density. Schematic diagrams of the backscatter and direct transmission gauges are illustrated in plate 2.

8. Backscatter-type nuclear density gauges are predicated on the use of the Compton effect absorption principle of medium-energy gamma photons. A definite relation exists between the number of gamma photons that are scattered back from a material and the density of the material. A special case of the backscatter nuclear density method is the air-gap backscatter method. Kühn¹ proposed that the introduction of a deliberate air gap between the nuclear instrument and the soil might reduce calibration errors caused by chemically different soils. The air gap at which a maximum reading divided by the reading at the surface of the material occurs is then computed for different densities to establish calibration curves. A schematic diagram of the air-gap method is presented in plate 2.

9. Previous studies^{2,4} have indicated that the volume of soil for which the density is determined by both the backscatter and direct transmission nuclear methods varies from approximately 0.05 to 0.1 cu ft,* depending on the density and water content of the material. The depth of density measurement varies from approximately 2 to 8 in. for the backscatter method, and extends to the depth of the source for the direct transmission method.

Soil Water Content Measurements

10. The nuclear measurement of soil water content is predicated on the principle that when a

* A table of factors for converting British units of measurement to metric units is presented on page ix.

high-energy neutron collides with a nucleus of an atom very much heavier than the neutron, little energy is lost by the neutron. However, when the neutron collides with a nucleus of similar mass, the neutron loses considerable energy and becomes a slow or low-energy neutron. The hydrogen nucleus, which has approximately the same mass as the neutron, is the most effective element in slowing fast neutrons. Therefore, the number of neutrons slowed down by transmission through soil is a function of the water content, since most hydrogen found in soil is in the form of soil moisture. The amount of water in a given soil mass can be determined by emitting fast neutrons into the soil and counting the number of slow neutrons that are scattered back. A schematic diagram of the backscatter moisture measurement technique is given in plate 2. Results of the studies referenced in paragraph 9 indicated that the volume of the soil in which the water content is measured varies from approximately 0.05 to 0.1 cu ft, depending on the density and water content of the soil. The depth measured varies from approximately 2 to 8 in.

DESCRIPTION OF EQUIPMENT AND TEST PROCEDURES

Equipment

11. *Nuclear instruments.* Many nuclear instruments for measuring soil water content and density are available from various manufacturers. These instruments consist of both separate and combined water content and density gauges. A proprietary instrument designated as Product A was selected for testing in this investigation. This instrument was chosen because it is a combination water content and density gauge utilizing both the direct transmission and backscatter techniques for density measurements, and therefore expedites test procedures by eliminating the need for multiple instruments. This instrument contains a double-encapsulated 3-millicurie source of radium-beryllium that emits both gamma photons and fast neutrons. The source is sealed in the density probe rod. Neutron and gamma shielding is provided inside the gauge so that the radiation level at the surface of the gauge at no point exceeds 50 millirads per hr. No license is required by the Atomic Energy Commission (AEC) for the possession of this source, as it is a naturally occurring radionuclide. However, the AEC has established standards for protection against radiation in Title 10, Part 20, Code of Federal Regulations,⁵ which provides, among other things, that (a) the maximum radiation dose per person be 3 rems per quarter, (b) the source be shielded as much as possible, (c) a maximum distance be maintained between a source and an operator at all times, (d) radiation film badges (dosimeters) be used by all personnel concerned to monitor accumulated dose, and (e) the sources be wipe-tested every six months.

12. *Conventional density equipment.* Conventional density equipment and test methods used are as described in ASTM D 2167-66 and D 1556-64, Density of Soil in Place by the Rubber-Balloon⁶ and Sand-Cone⁷ Methods (for rough surfaces), respectively.

General Laboratory Procedure

13. The laboratory testing procedure was planned to obtain uniformly compacted soil samples of known volume with various densities and water contents for testing. This was accomplished by constructing 2-ft by 2-ft by 9-in. boxes with a volume of exactly 3 cu ft. These dimensions were selected, based on the results of previous studies,^{2,4} to provide the minimum volume of soil necessary to represent an infinite mass to the nuclear gauges. Densities and water contents were varied to obtain a range from the approximate minimum practical density obtainable using a heavy clay with a small compaction effort to the approximate maximum obtainable density using a very well-graded crushed limestone placed at about optimum water content with a great compaction effort. Test soil was placed in the boxes and compacted

uniformly to produce 3-in.-deep layers. The surface of each layer of soil was scarified before the next layer was placed. A steel collar was placed at the tops of the boxes so that they could be slightly overfilled to aid in striking off the soil for the final surface. Care was taken in striking off the final surface to obtain as smooth a test surface as practical even with the more granular soils. The density of each sample was then determined by weighing the box containing the compacted soil and dividing by the volume. A general view of a box being filled and compacted is presented in fig. 1. A typical test setup showing a box containing compacted soil and the nuclear gauge and scaler with operator is shown in fig. 2.



Fig. 1. Sample preparation

14. At the beginning and end of each test day, nuclear density and water content standard counts were taken on the reference standard furnished with the nuclear gauge.

15. The surface backscatter nuclear density and water content tests were nondestructive and were performed with the probe of the nuclear gauge in the position shown in plate 3a. The direct transmission density test as illustrated in plate 3b, requires that a hole be driven into the soil sample with a hammer and steel rod for insertion of the probe. The probe can be inserted to any depth up to 12 in. A 6-in. depth was selected for test purposes, as this is considered representative of the average construction lifts that might be placed in the field.

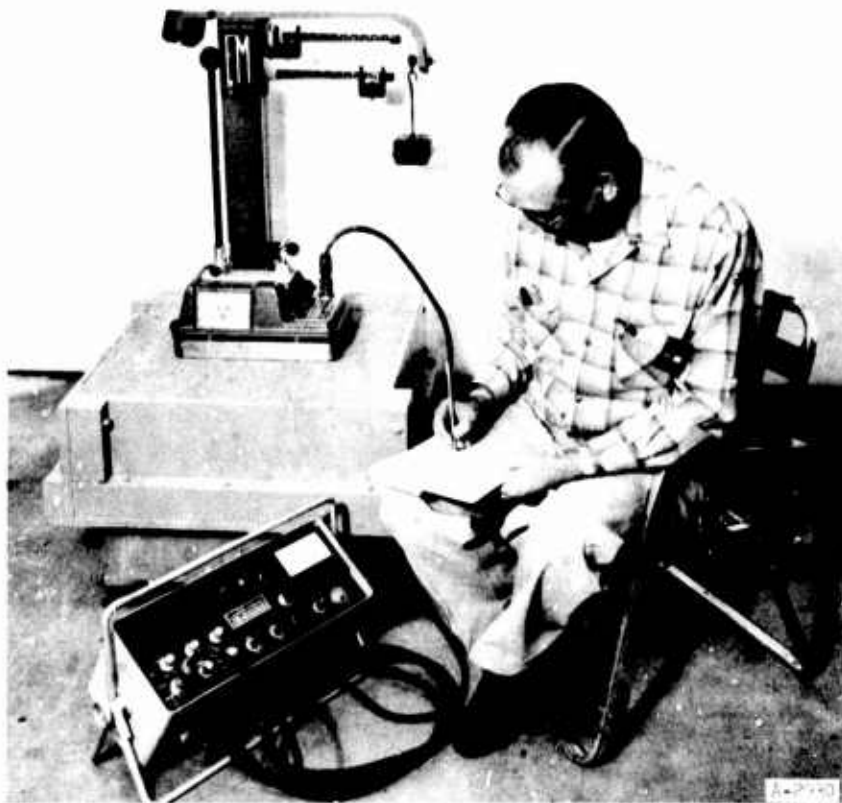

Fig. 2. Test setup with a nuclear gauge

16. An air-gap cradle with adjustable legs was constructed to hold the nuclear gauge for the air-gap backscatter readings. The optimum air gap was determined by taking a series of counts on each soil type in 1/4- to 1/2-in. increments from the surface count through a 2-1/2-in. air-gap count. The maximum point for each soil type curve varied slightly, but the approximate average of the five soils fell at 2 in. (plate 4).

17. The following nuclear tests were performed on each soil sample: surface water content, surface backscatter density, air-gap backscatter density, and direct transmission density (6-in. depth). Calibration curves furnished by the manufacturer were used to convert instrument readings to density or water content. Generally, these calibration curves were developed by the manufacturer from a few readings taken on cast materials of various densities and water contents. The calibration curves developed by the U. S. Army Engineer Waterways Experiment Station (WES) and presented herein were obtained using the line-of-best-visual-fit method on the plotted data obtained from nuclear readings on the 40 samples tested. Therefore, the WES curves were developed from more data and are probably more accurate. A simple linear regression was not used to develop the WES curves because the data indicated a curve was applicable rather than a straight line.

18. In order to obtain water contents in the usual form, i.e., weight of water divided by dry weight, it was necessary to know the wet density from which to subtract the weight of water to obtain the dry density. The nuclear water contents were calculated using wet densities as obtained from the direct transmission nuclear density test as would be the case in an actual field nuclear moisture content test.

19. In addition to the nuclear tests, two sand-cone and two water-balloon density tests were performed on each sample. The results of the sand-cone and the water-balloon tests were averaged, and the

average values were used as the conventional densities. Water contents of four soil samples were determined using conventional oven-dried procedures.

TEST DATA ANALYSIS

20. A summary of the test data is presented in table 1. In order to obtain meaningful coefficients for statistical comparison of test results, the standard deviation and the average deviation of each nuclear or conventional density determination from the actual box density were determined. The results of the statistical analysis are shown in table 2. Also, a plot of the density and water content test results versus actual is presented for each test method in plates 5-12 in order to show the range of variation from the actual for each method.

Density Determinations

21. *Direct transmission nuclear density.* The results of the direct transmission nuclear density test for each soil sample are presented in table 1. A plot of the nuclear count ratio (probe count divided by standard count) versus actual average soil density for each sample is shown in plate 13. The WES calibration curve was developed using the line of best visual fit. The standard deviation and average deviation of the test results for both the factory and the WES-developed calibration curves are as follows:

	Standard Deviation <u>pcf</u>	Average Deviation <u>pcf</u>
Factory curve	3.39	2.62
WES curve	2.94	2.48

The standard deviation of the direct transmission density test results using the factory curve was slightly less than those of densities determined by conventional means (sand cone, 3.53 pcf; water balloon, 3.49 pcf). The WES curve provided slightly more accurate results than the factory curve.

22. *Surface backscatter nuclear density.* The results of the surface backscatter nuclear density tests for each soil sample are listed in table 1. The standard deviation and average deviation of the test results for both the factory and the WES-developed curves are as follows:

	Standard Deviation <u>pcf</u>	Average Deviation <u>pcf</u>
Factory curve	4.10	3.49
WES curve	4.10	3.35

A plot of the nuclear count ratio (surface count divided by standard count) versus actual average soil density for each sample is shown in plate 14. The WES curve was developed using the line of best visual fit. Both the factory curve and the WES curve are very flat. Because of their flat geometry, a small variation in count ratio causes a relatively large variation in density. Also, previous studies²⁻⁴ have indicated that the accuracy of nuclear densities obtained by the surface backscatter method is greatly affected by soil surface roughness. Since great care was taken to obtain a smooth surface for testing on each sample, the 4.10-pcf standard deviation obtained for this method is considered lower than might be expected for actual fieldwork. Even so, this standard deviation (4.10 pcf) is greater than that obtained by conventional

methods. Therefore, it is felt that the surface backscatter density method should be used only when a relatively smooth soil surface can be obtained, and then only when approximate results are acceptable.

23. *Air-gap backscatter nuclear density.* The results of the air-gap backscatter density tests for each soil sample are listed in table 1. The air-gap count ratio (2-in. air-gap count divided by surface count) is plotted versus actual average soil density in plate 15. The air-gap calibration curve was developed using the line of best visual fit and is shown in plate 15. Air-gap densities were determined from this calibration curve and were compared with the actual average densities to obtain standard deviation. The standard deviation and average deviation obtained for the air-gap method were 3.93 and 3.29 pcf, respectively. Although the 3.93-pcf standard deviation for the air-gap method is slightly better than the 4.10-pcf standard deviation obtained for the surface backscatter method, it is greater than the deviation obtained by conventional methods. Therefore, it is felt that the air-gap method should be considered no more reliable than the surface backscatter method because density determinations using an air-gap count ratio (air-gap count divided by surface count) can be only as good as the surface count, which is subject to the inaccuracies mentioned before.

Water Content Determinations

24. The results of nuclear soil water content tests are presented in table 1. A plot of the nuclear count ratio (surface count divided by standard count) versus water content in pcf for each soil sample is shown in plate 16. Also shown in plate 16 are the factory calibration and the WES calibration curves, the latter being the line of best visual fit. The standard deviation and average deviation of the nuclear water contents (percent of water by dry weight) for both the factory and WES calibration curves are as follows:

	Standard Deviation %	Average Deviation %
Factory curve	3.81	3.21
WES curve	1.23	0.98

The WES-developed calibration curve proved considerably more accurate than the factory curve for water content measurements. The results obtained using the factory curve were not sufficiently accurate for anything other than work requiring approximate water contents. However, the WES-developed curve provided measurements sufficiently accurate for most field control use. Even though the factory calibration curve proved inaccurate, it is felt that the nuclear moisture gauge is adequate for field control use because a suitable curve could be developed in about two days.

Radiation Dosage

25. Examination of the film badges worn by individuals during the testing indicated that the maximum accumulated radiation dose of any individual during the three-month period was 0.016 rem.

DISCUSSION OF RESULTS

26. Based on the results of this and previous studies,²⁻⁴ the direct transmission nuclear density method using the factory calibration curve can provide surface in situ soil densities of an accuracy comparable to densities obtained by conventional methods (sand cone and water balloon). However, it should be pointed out that each gauge is more or less an individual and is subject to individual calibration due to the unique relation between the individual nuclear source, gauge, and scaler. Therefore, even though the

theory of direct transmission density determinations has been proven sound and the results accurate, density checks should be made on each new gauge with its factory calibration curve before complete acceptance of the gauge for quality control use. General procedures recommended for the optimum operation of nuclear moisture and density gauges are presented in Appendix A.

27. Densities obtained using the surface backscatter nuclear density method were not so accurate as those obtained by conventional methods. However, the surface backscatter nuclear density method could be useful in cases in which only approximate results from an expedient nondestructive test are required.

28. The surface backscatter nuclear water content method, using a locally developed calibration curve, can provide water content determinations within ± 1.5 percent of actual moisture content as determined from oven-dried samples, which should be sufficiently accurate for most field control work. The nuclear method of determining water content using the factory calibration curve proved considerably less accurate and indicated that the surface backscatter nuclear method using the factory calibration curve should be used only when approximate results are acceptable.

29. The degree of accuracy of the various nuclear methods presented herein was determined under closely controlled laboratory conditions. However, it is felt that comparable accuracies can be obtained in the field if the nuclear gauges are operated on a relatively smooth surface by experienced technicians.

30. The primary advantage of the nuclear methods is the speed with which density and water content determinations can be obtained as compared with conventional methods. An in situ density and water content determination can be made in approximately 15 min as compared with 24 hr required for conventional methods. In addition, the possibility of human error is minimized because the number of operations and calculations required to obtain field results by nuclear means is considerably less than with conventional methods.

31. The primary disadvantage of nuclear methods of determining field densities and water contents is the general lack of understanding of the methods, and, consequently, lack of confidence in the results. Another disadvantage is that individual calibration curves must be developed and evaluated for each instrument. Also, safety regulations and requirements are stringently enforced, especially in the Federal service, and for this reason field parties are sometimes reluctant to use nuclear equipment. Safety regulations are necessary and important, but common sense should be used in their enforcement to make them flexible enough to safeguard personnel while accomplishing the job efficiently.

32. The maximum radiation dosage per person allowed by the AEC is 3 rems per quarter. The maximum accumulated radiation dose obtained by any individual for the 3-month testing period during this study was 0.016 rem. Therefore, it is felt that the use of nuclear gauges will present no detrimental health effects provided normal safe operating procedures are followed.

LITERATURE CITED

1. Kuhn, S. H., "Effects of Type of Material on Nuclear Density Measurements," *Nuclear Measurements, 1963*, Highway Research Record No. 66, pp 1-14, 1965, National Academy of Sciences - National Research Council, Washington, D. C.
2. Womack, L. M., "A Study of Surface-Type Nuclear Instruments for Determining Soil Moisture and Density," Miscellaneous Paper No. 4-495, May 1962, U. S. Army Engineer Waterways Experiment Station, CE, Vicksburg, Miss.
3. California Division of Highways, "A Basic Study of the Nuclear Determination of Moisture and Density," Research Report No. 225928, Nov 1965, Materials and Research Department, Sacramento, Calif.
4. Weber, W. G., Jr., "Laboratory and Field Evaluation of Nuclear Surface Gages for Determining Soil Moisture and Density," *Nuclear Measurements, 1963*, Highway Research Record No. 66, pp 51-72, 1965, National Academy of Sciences - National Research Council, Washington, D. C.
5. Atomic Energy Commission, "Standards for Protection Against Radiation," *Code of Federal Regulations*, Title 10, Part 20, 9 Aug 1966, Government Printing Office, Washington, D. C.
6. American Society for Testing and Materials, "Standard Method of Test for Density of Soil in Place by the Rubber-Balloon Method," Designation: D 2167-66, *1968 Book of ASTM Standards*, Part 11, Mar 1968, Philadelphia, Pa., pp 634-637.
7. _____, "Standard Method of Test for Density of Soil in Place by the Sand-Cone Method," Designation: D 1556-64, *1968 Book of ASTM Standards*, Part 11, Mar 1968, Philadelphia, Pa., pp 463-467.

BLANK PAGE

Table 1
Summary of Test Data

Type Material	Average Box Density pcf*	Density as Determined by Nuclear Methods, pcf					Density as Determined by Conventional Methods, pcf**		Water Content %		
		Direct Transmission		Backscatter			Sand Cone	Water Balloon	Nuclear		Actual Oven- Dried
		Factory Curve	WES Curve	Factory Curve	WES Curve	Air-Gap Curve			Factory Curve	WES Curve	
Clay	89.2	90.8	89.2	89.0	90.0	91.5	92.8	94.3	23.7	23.0	26.4
	113.7	113.9	115.5	116.0	120.5	120.0	114.9	114.4	28.4	35.7	33.8
	99.0	100.6	101.5	100.0	102.5	104.0	89.6	89.5	25.6	26.7	26.8
	107.2	107.5	109.8	107.5	111.5	110.5	112.5	112.3	29.5	37.3	38.7
	107.8	107.0	108.8	106.5	109.0	109.5	107.9	107.0	30.0	37.9	40.0
	111.0	114.0	115.8	117.0	121.0	119.5	112.1	112.8	26.2	31.9	32.4
	104.0	107.0	108.8	109.0	112.5	110.5	107.1	106.0	30.2	37.9	36.4
	106.0	107.0	108.8	109.0	112.5	110.5	109.2	107.1	30.2	37.9	36.7
Lean clay	107.3	106.0	108.0	108.5	109.0	108.5	111.2	111.4	17.1	14.8	16.6
	122.8	123.0	124.5	121.5	127.0	125.0	126.3	125.2	17.9	17.9	19.3
	104.2	103.0	104.0	109.5	112.0	110.5	108.3	109.6	12.9	9.9	11.4
	108.2	107.5	110.0	107.5	109.0	110.5	111.4	108.6	17.2	19.4	18.1
	117.0	118.0	119.8	116.0	120.5	120.0	117.1	119.5	16.1	19.6	19.8
	117.5	116.5	117.5	116.0	121.0	120.0	117.3	116.9	14.4	15.6	14.5
	112.8	112.0	114.5	112.0	115.0	115.5	118.6	116.8	15.0	16.7	15.7
	100.7	100.5	101.0	97.5	99.0	100.0	101.1	102.7	14.8	11.9	12.7
Sand	100.8	97.5	97.6	95.0	96.0	99.5	101.6	101.8	6.2	2.6	4.6
	115.2	108.0	109.8	113.5	109.0	111.0	114.4	111.5	10.2	7.2	7.8
	105.7	101.5	103.2	98.5	101.0	104.0	109.5	105.8	8.9	5.4	5.4
	107.2	103.5	104.9	100.0	102.5	106.0	103.6	104.2	8.2	5.5	5.1
	108.0	102.5	104.2	101.0	103.5	107.0	107.8	105.8	9.1	6.8	7.0
	107.0	109.5	111.9	100.0	102.5	105.5	110.7	110.0	11.3	10.0	9.8
	112.7	105.0	107.2	106.0	107.0	109.5	109.9	110.0	11.4	8.2	8.9
	108.7	104.5	106.0	101.0	103.0	115.5	108.6	109.7	9.4	6.4	5.6
	Gravel	123.7	117.5	119.2	116.0	121.0	121.0	128.1	127.4	8.0	5.1
127.0		119.8	121.0	120.0	125.6	126.0	129.7	129.4	7.5	4.5	4.3
115.2		108.5	111.0	117.5	112.0	113.0	116.9	119.8	6.6	3.4	3.5
123.0		118.0	119.5	116.5	120.5	123.0	125.7	129.1	7.9	5.7	5.8
125.3		121.5	122.7	118.0	124.0	123.0	117.9	122.3	7.0	4.8	3.8
120.0		116.5	118.2	113.5	117.0	118.0	121.5	121.7	6.2	4.6	3.0
139.7		139.5	139.0	134.5	141.5	139.5	142.8	143.8	12.5	11.1	9.0
139.3		140.0	140.5	133.5	140.0	138.5	138.2	137.6	12.1	10.4	8.6
Limestone	135.3	136.5	136.0	128.3	134.5	129.0	137.8	139.1	9.3	7.1	6.2
	132.2	129.0	129.5	135.4	134.0	127.0	132.2	132.4	7.9	5.3	4.2
	127.3	129.5	130.5	123.0	129.0	124.0	132.6	130.0	6.1	3.0	2.7
	125.7	127.0	128.0	122.0	127.5	121.5	131.5	130.1	6.0	3.8	3.3
	127.3	129.5	129.3	123.0	129.0	124.0	127.3	129.8	4.7	2.4	2.5
	129.8	131.5	131.3	125.0	130.5	124.5	130.7	128.6	4.9	2.6	2.1
	130.5	132.0	131.8	125.0	130.5	124.5	132.2	131.1	4.6	2.2	2.0
	133.0	135.0	135.0	127.0	132.0	126.0	138.5	140.2	8.9	6.7	5.5

* Determined from volume of box and weight of compacted sample.

** Each value is an average of two determinations.

Table 2
Statistical Analysis of Test Results

	Deviation, pcf	
	<u>Standard*</u>	<u>Average**</u>
<u>Conventional Density Methods</u>		
Water balloon	3.49	2.85
Sand cone	3.53	2.76
<u>Nuclear Density Methods</u>		
Direct transmission		
Factory calibration curve	3.39	2.62
WES calibration curve	2.94	2.48
Backscatter		
Factory calibration curve	4.10	3.49
WES calibration curve	4.10	3.35
Air gap (WES curve)	3.93	3.29
<u>Water Content as Determined by Nuclear Method†</u>		
Factory calibration curve	3.81	3.21
WES calibration curve	1.23	0.98

* The square root of the means of the squares of the individual deviations of the nuclear and/or conventional measurements from the actual measurements.

** The average of the deviations from the actual measurements.

† Water content deviations are given in percent, not pcf.

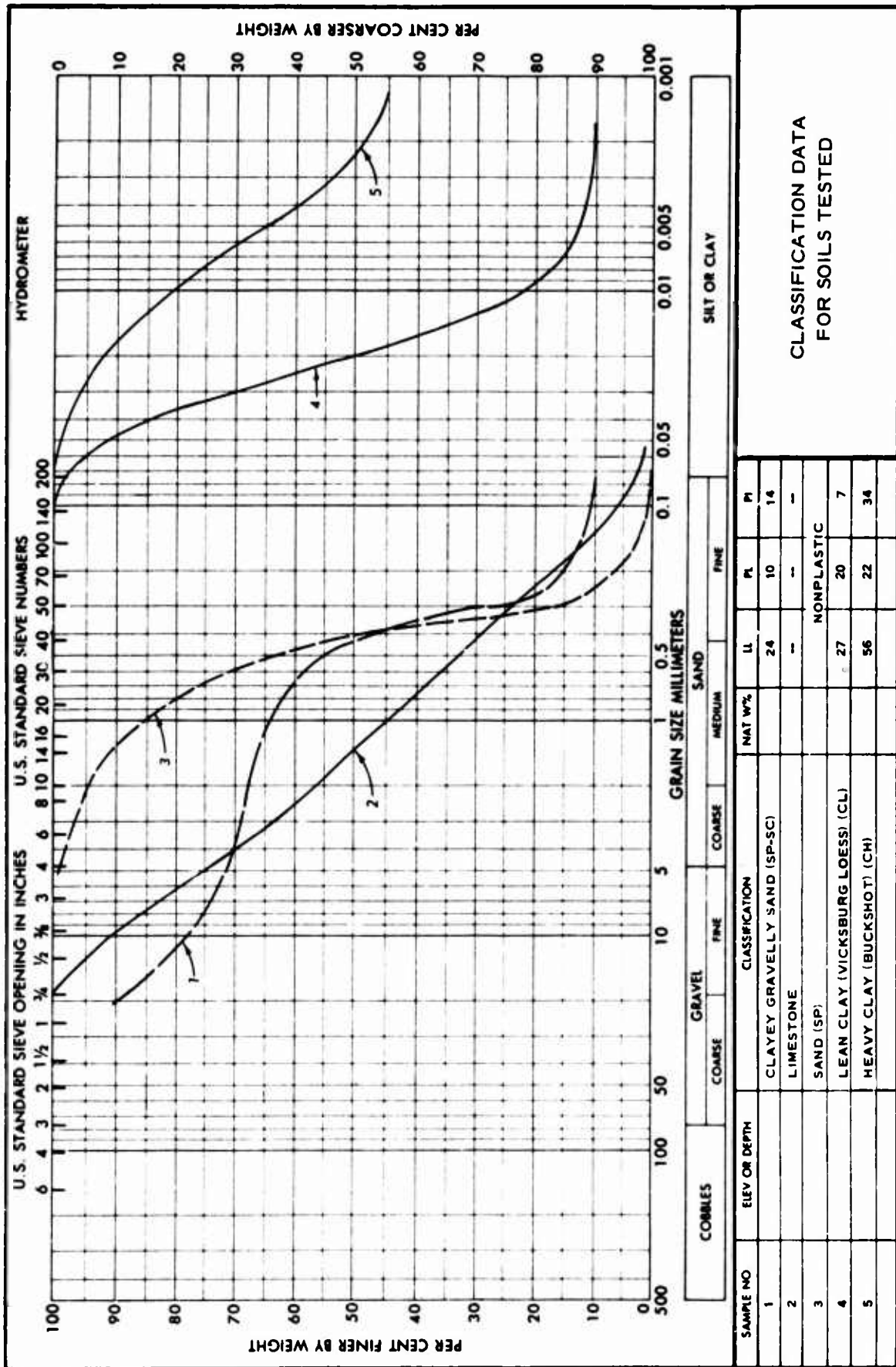

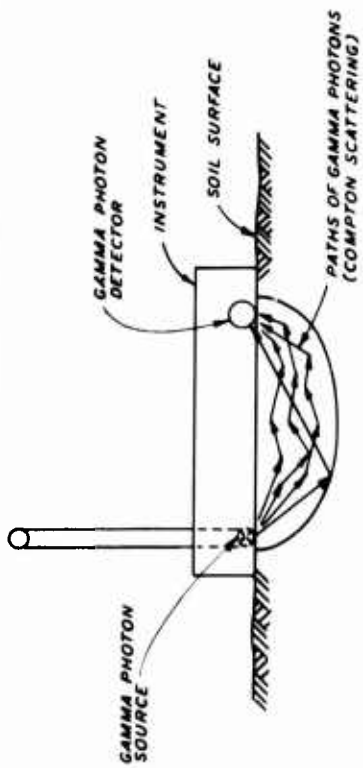

a. BACKSCATTER DENSITY MEASUREMENT

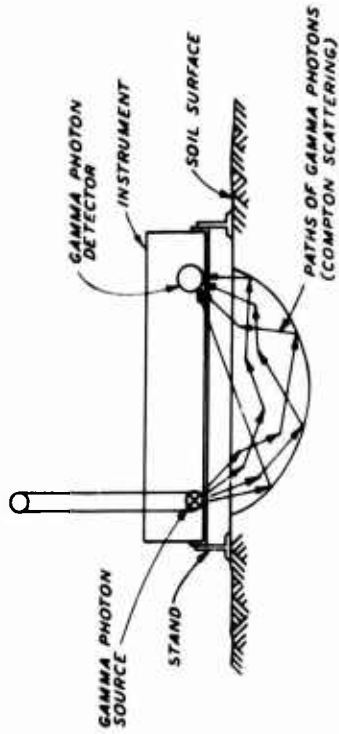

c. AIR-GAP DENSITY MEASUREMENT

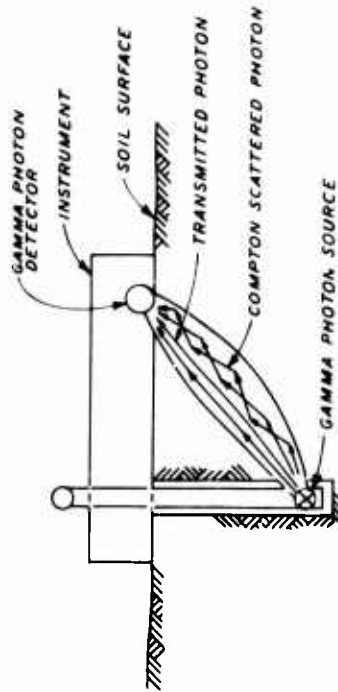

b. DIRECT TRANSMISSION DENSITY MEASUREMENT

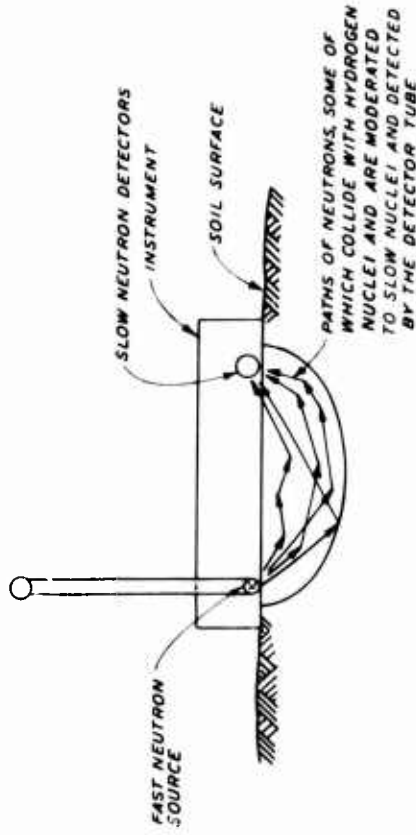

d. BACKSCATTER MOISTURE MEASUREMENT

SCHEMATIC DIAGRAMS OF DENSITY AND MOISTURE MEASUREMENTS

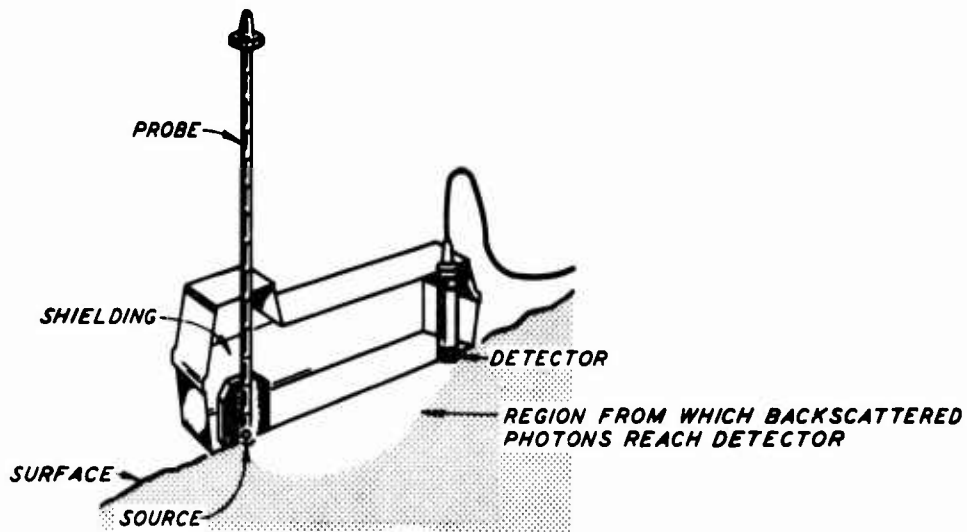

a. BACKSCATTER MOISTURE AND DENSITY METHOD

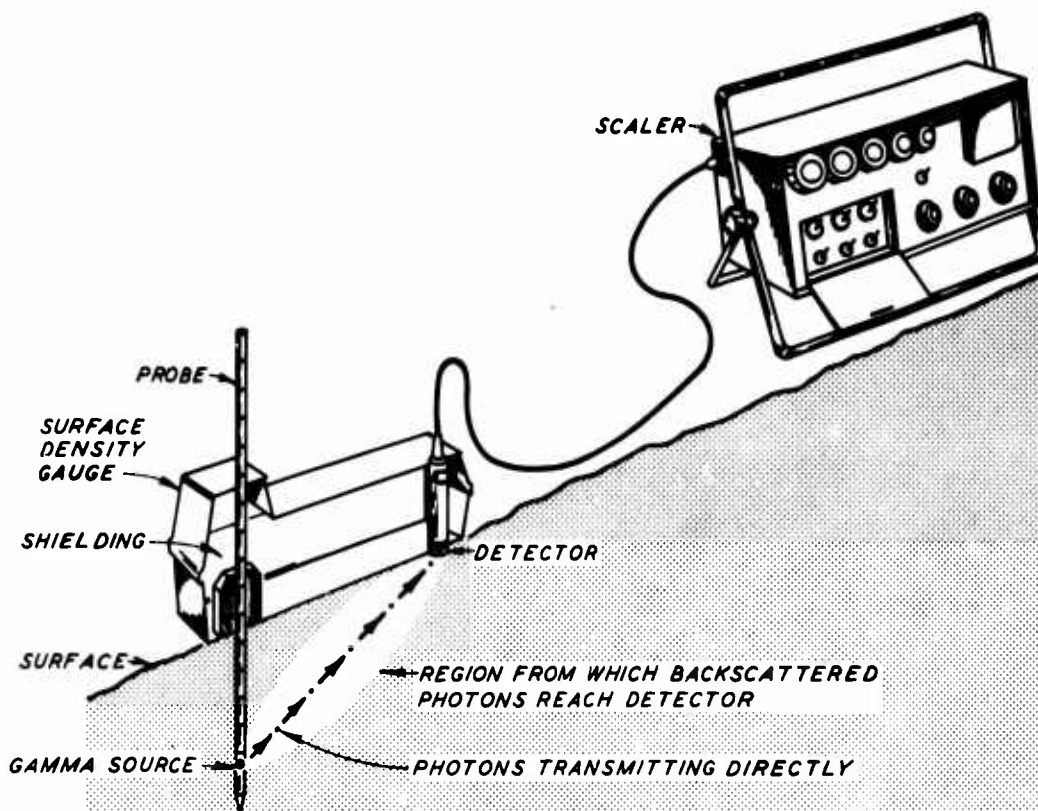

b. DIRECT TRANSMISSION DENSITY METHOD

MOISTURE AND DENSITY METHODS

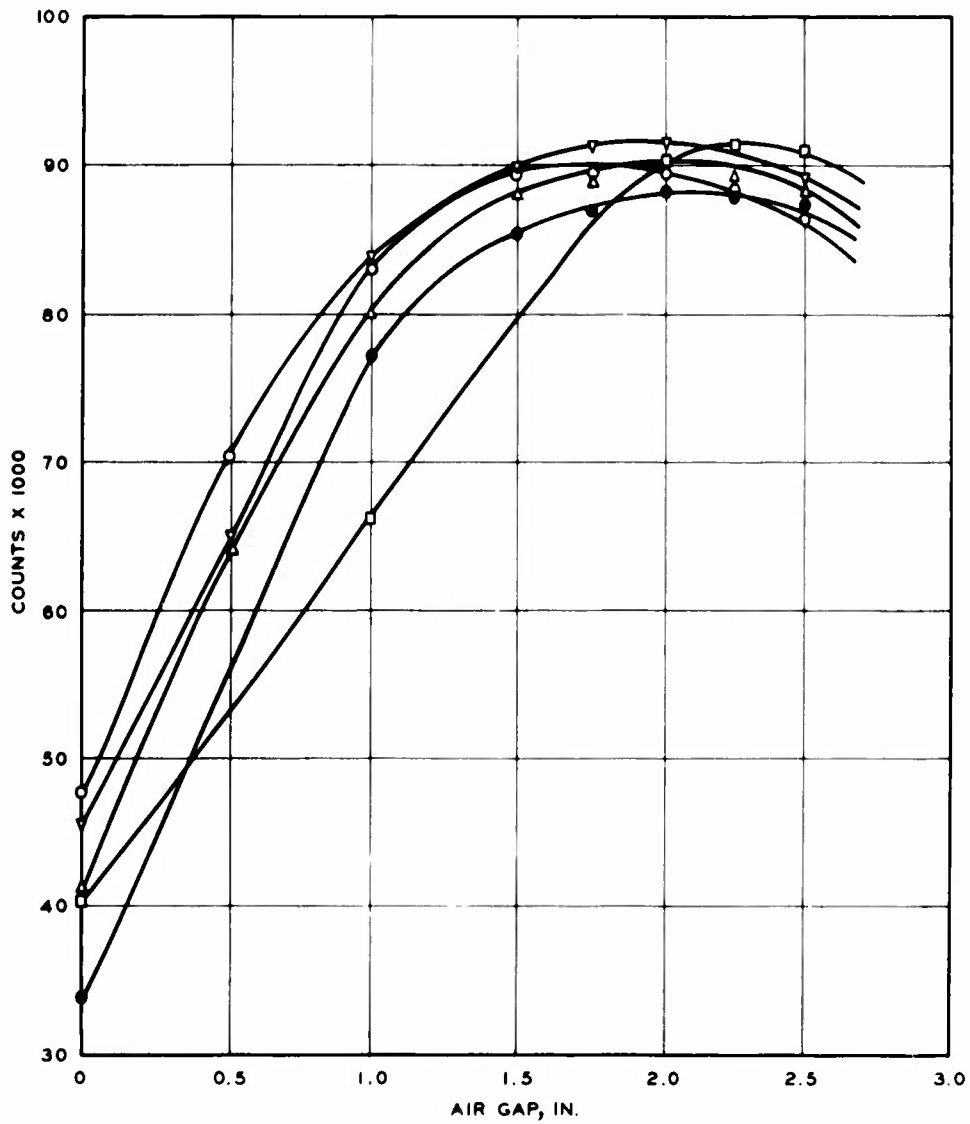

LEGEND

- CLAY (CL)
- Δ LEAN CLAY (CL)
- ▽ SAND (SP)
- CLAYEY GRAVELLY SAND (SP-SC)
- ◇ SAND (SP-SC)
- LIMESTONE

OPTIMUM AIR-GAP DETERMINATIONS

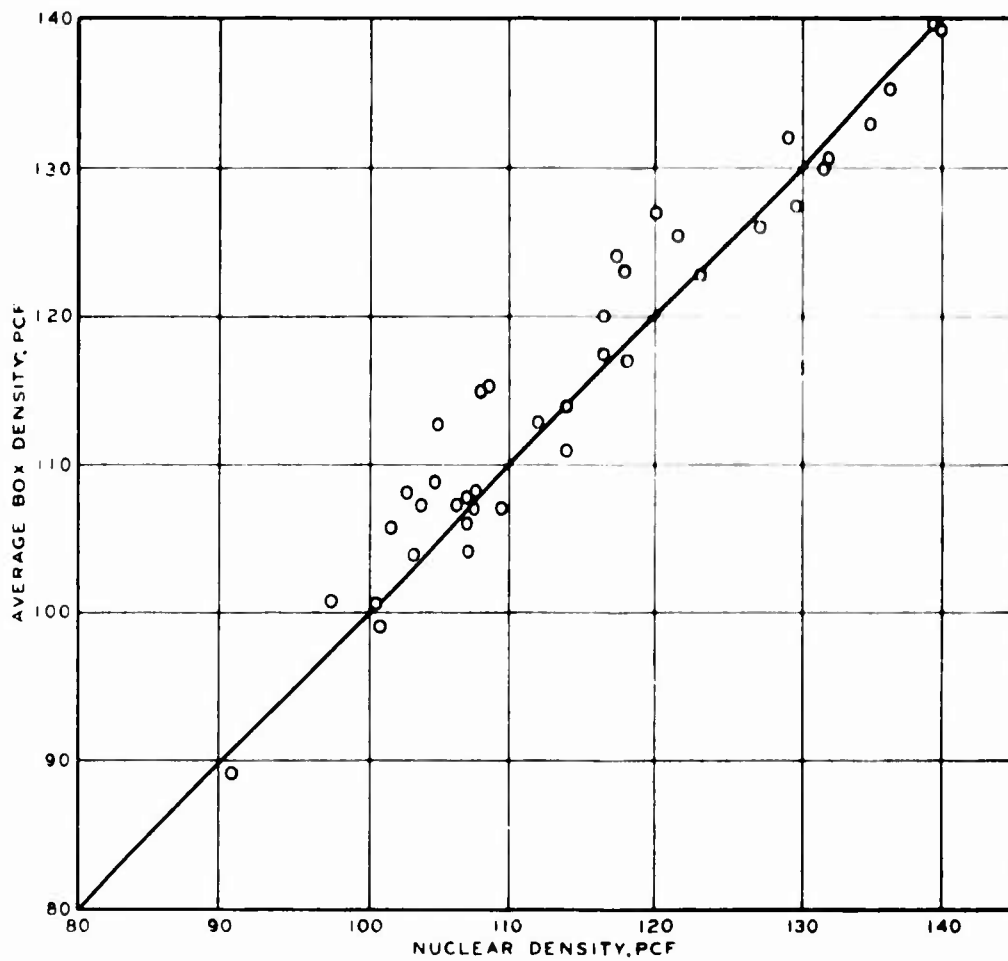

AVERAGE BOX DENSITY
 VS NUCLEAR DENSITY
 DIRECT TRANSMISSION METHOD
 FACTORY CURVE

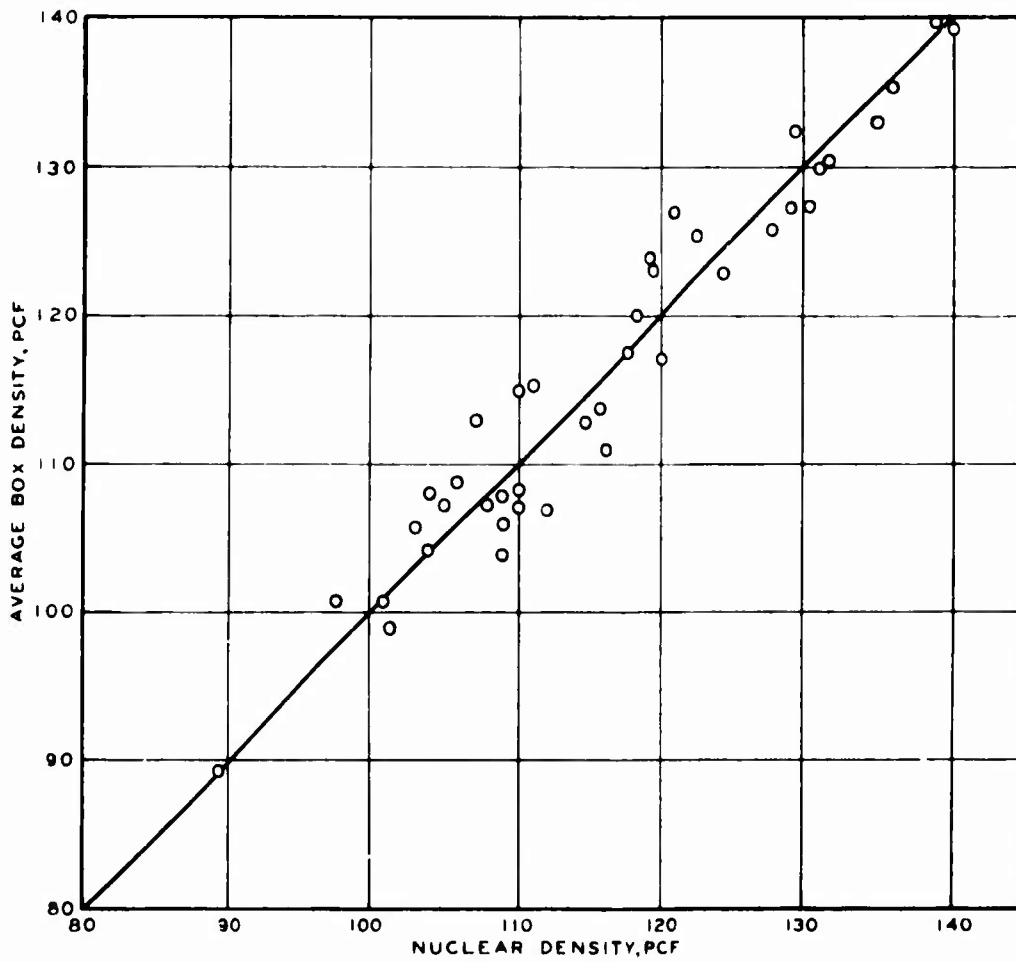

AVERAGE BOX DENSITY
 VS NUCLEAR DENSITY
 DIRECT TRANSMISSION METHOD
 WES CURVE

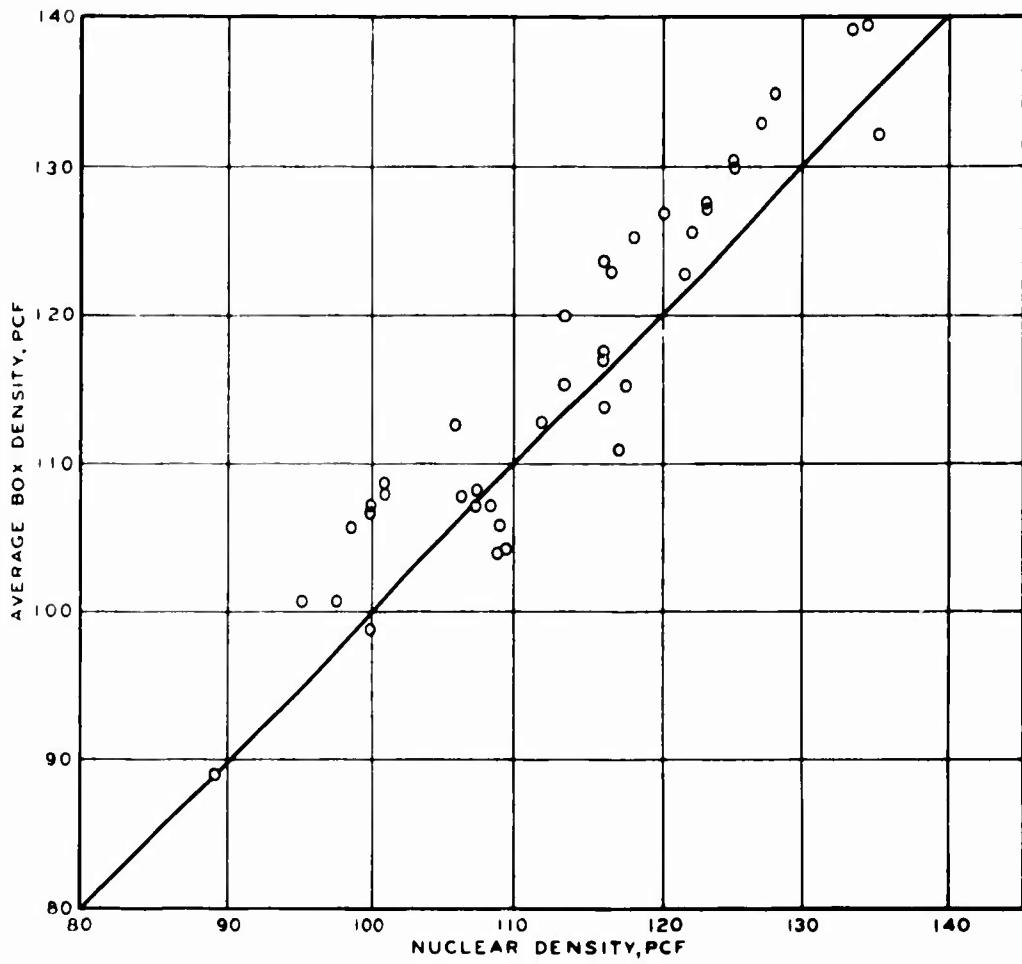

AVERAGE BOX DENSITY
VS NUCLEAR DENSITY
BACKSCATTER METHOD
FACTORY CURVE

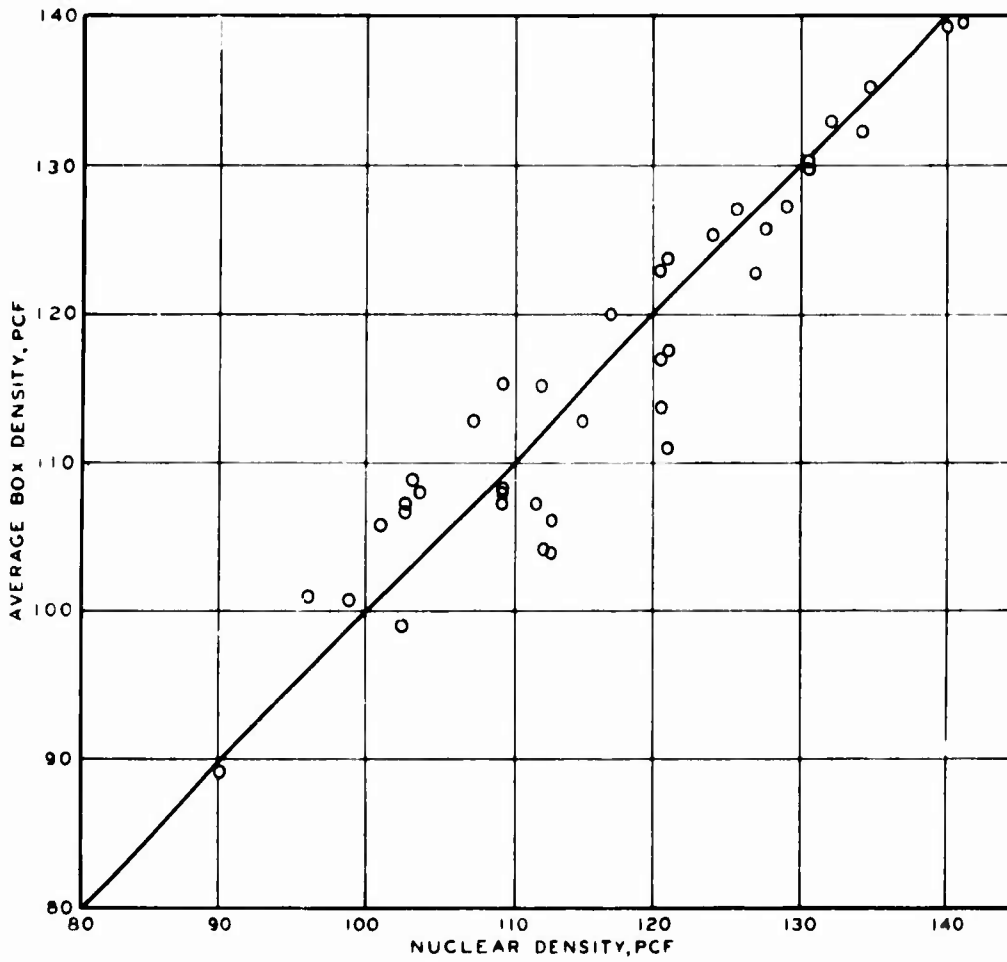

AVERAGE BOX DENSITY
VS NUCLEAR DENSITY
BACKSCATTER METHOD
WES CURVE

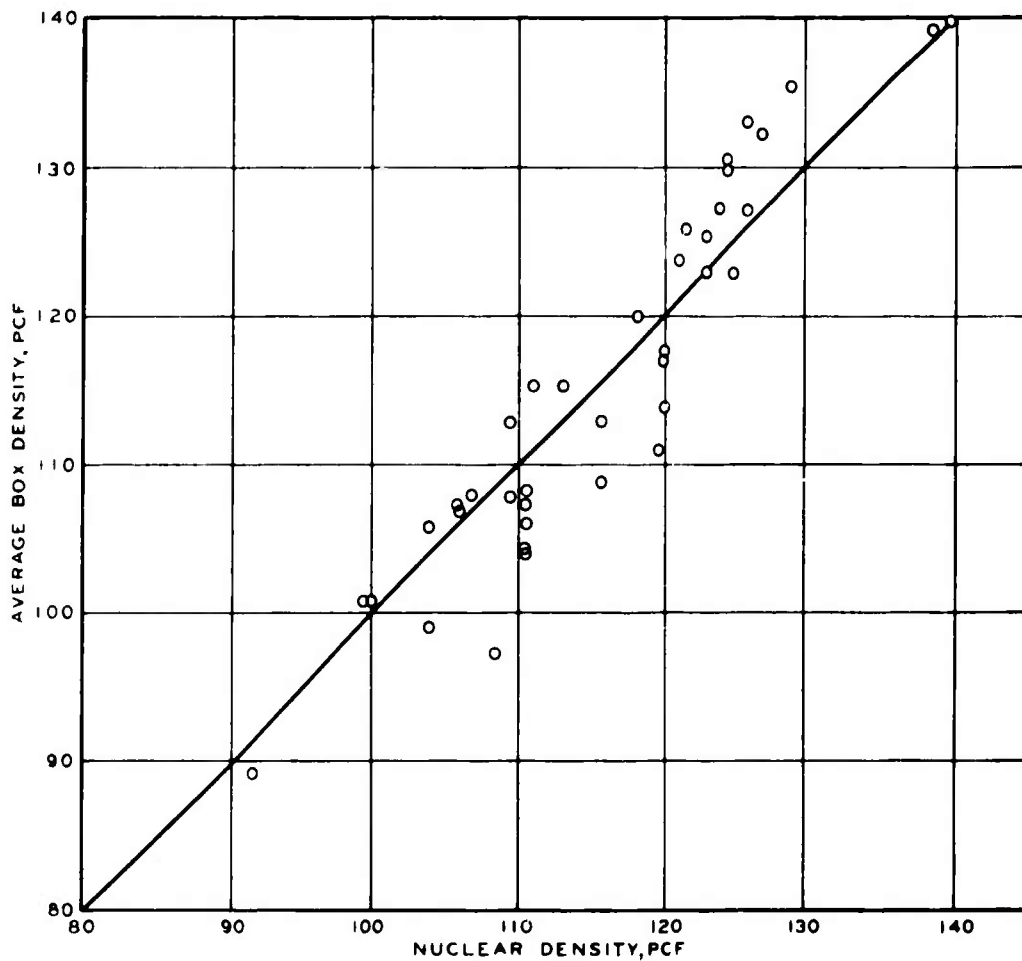

AVERAGE BOX DENSITY
VS NUCLEAR DENSITY
AIR-GAP BACKSCATTER METHOD
DEVELOPED CURVE

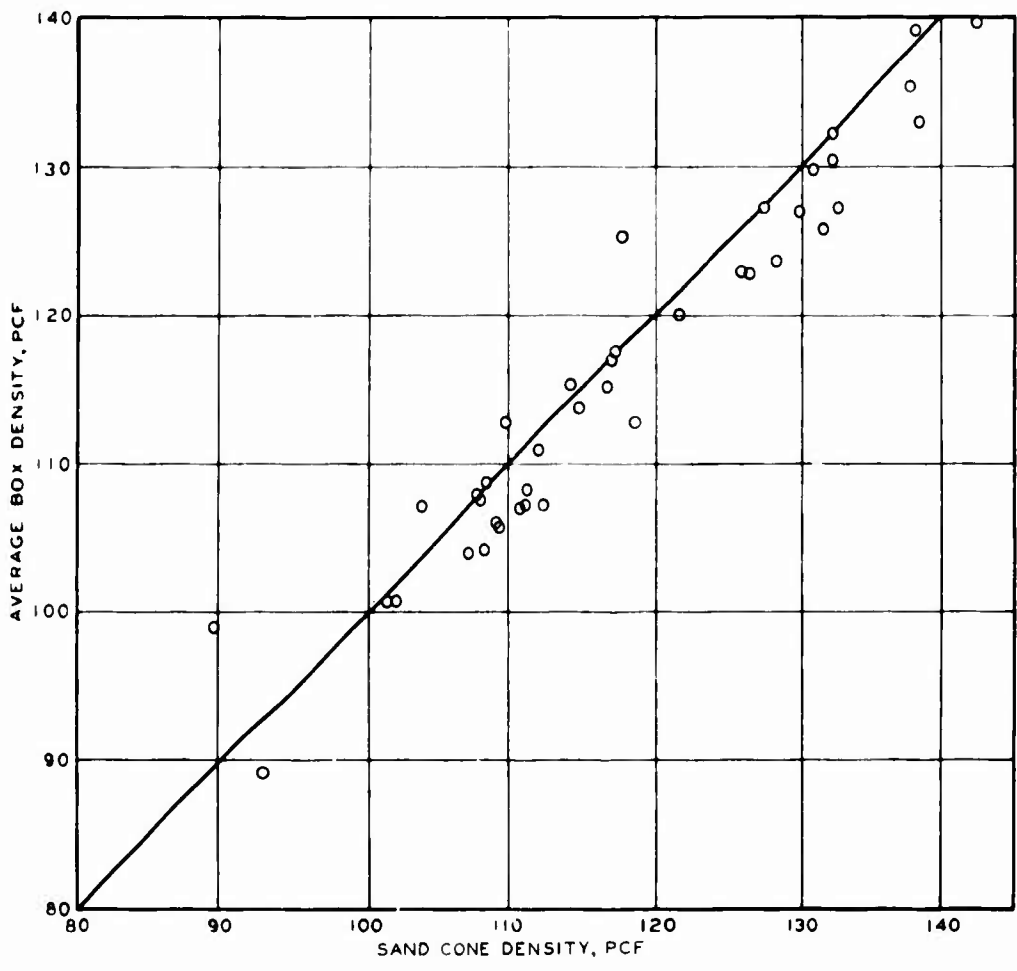

AVERAGE BOX DENSITY
VS SAND CONE DENSITY

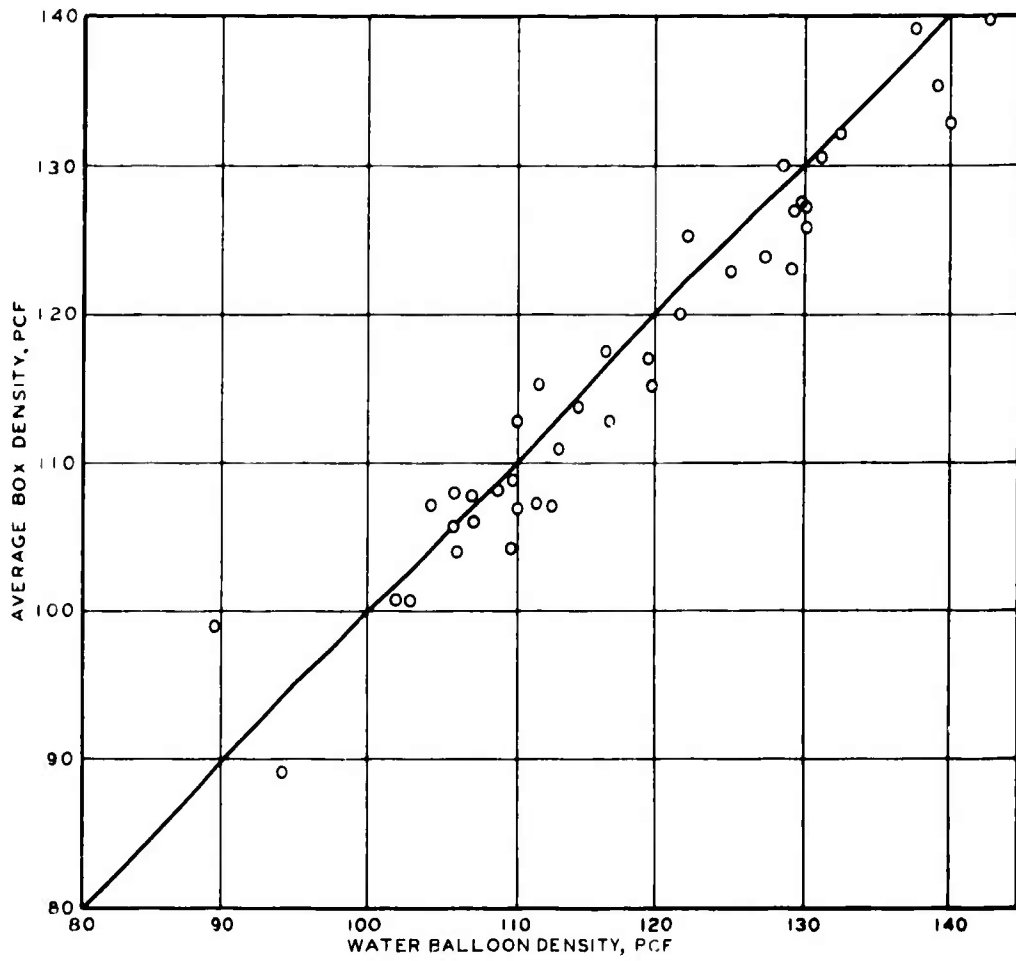

AVERAGE BOX DENSITY VS
WATER BALLOON DENSITY

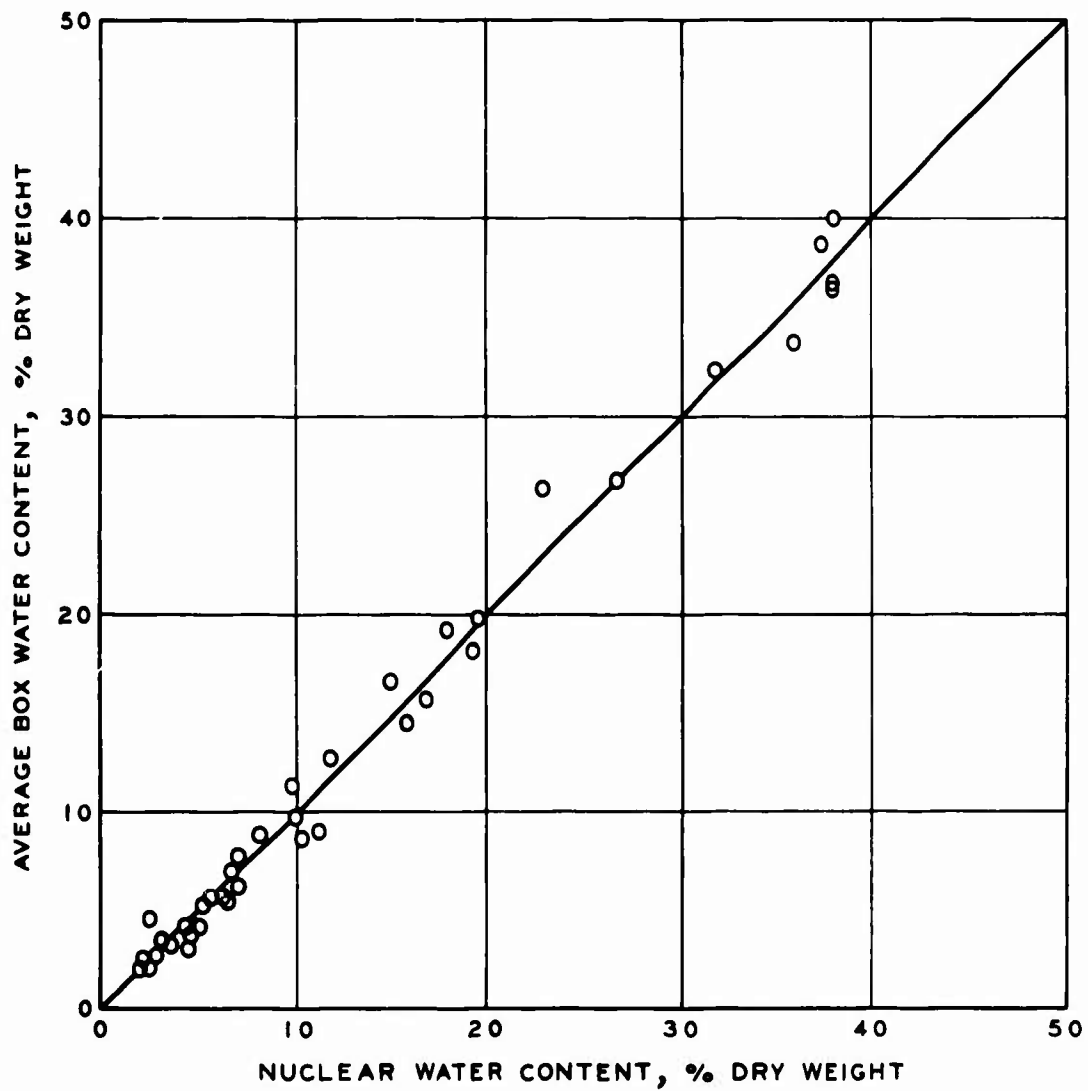

AVERAGE BOX
 WATER CONTENT
 VS NUCLEAR
 WATER CONTENT
 WES CURVE

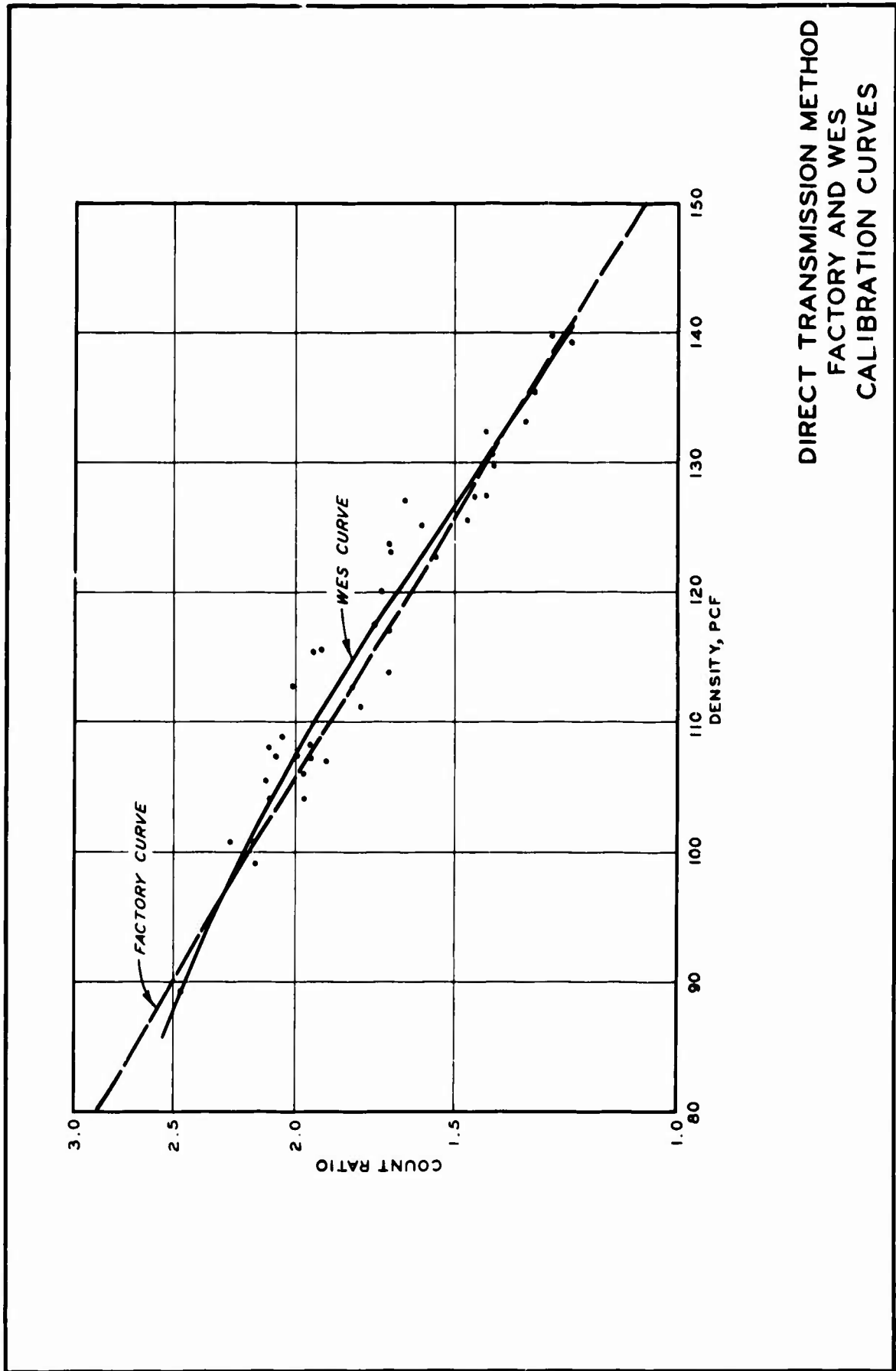

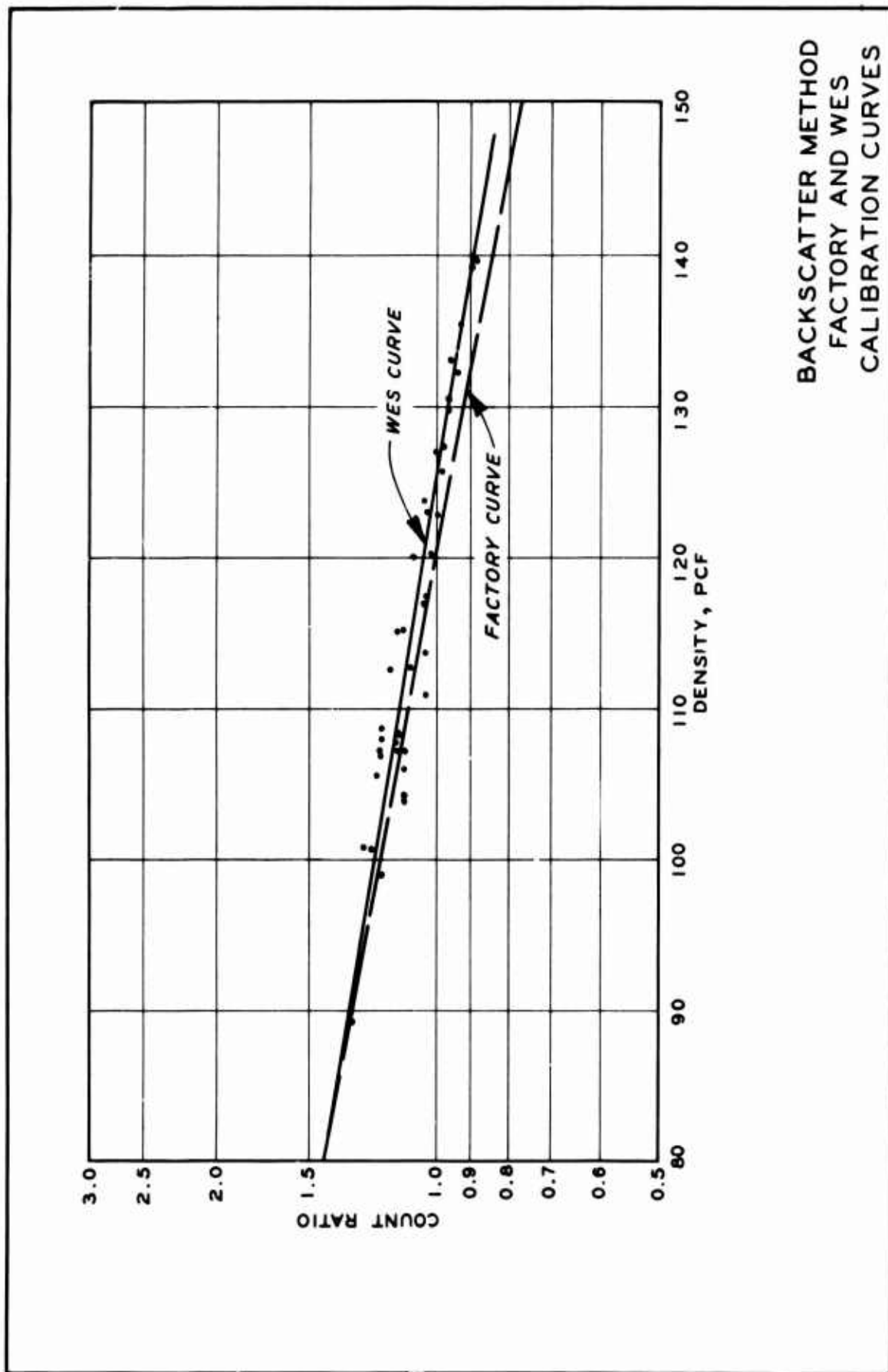

BACKSCATTER METHOD
FACTORY AND WES
CALIBRATION CURVES

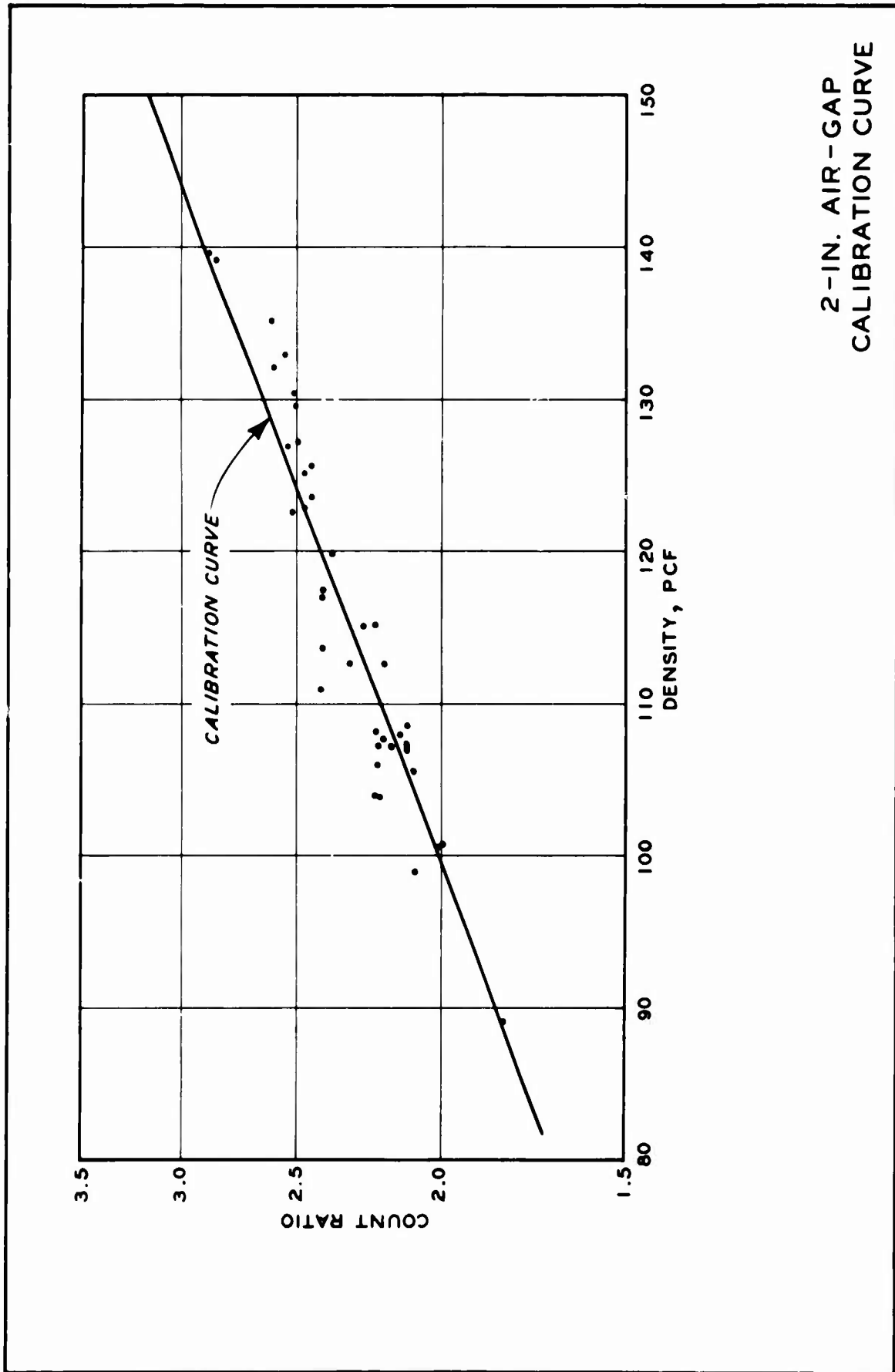

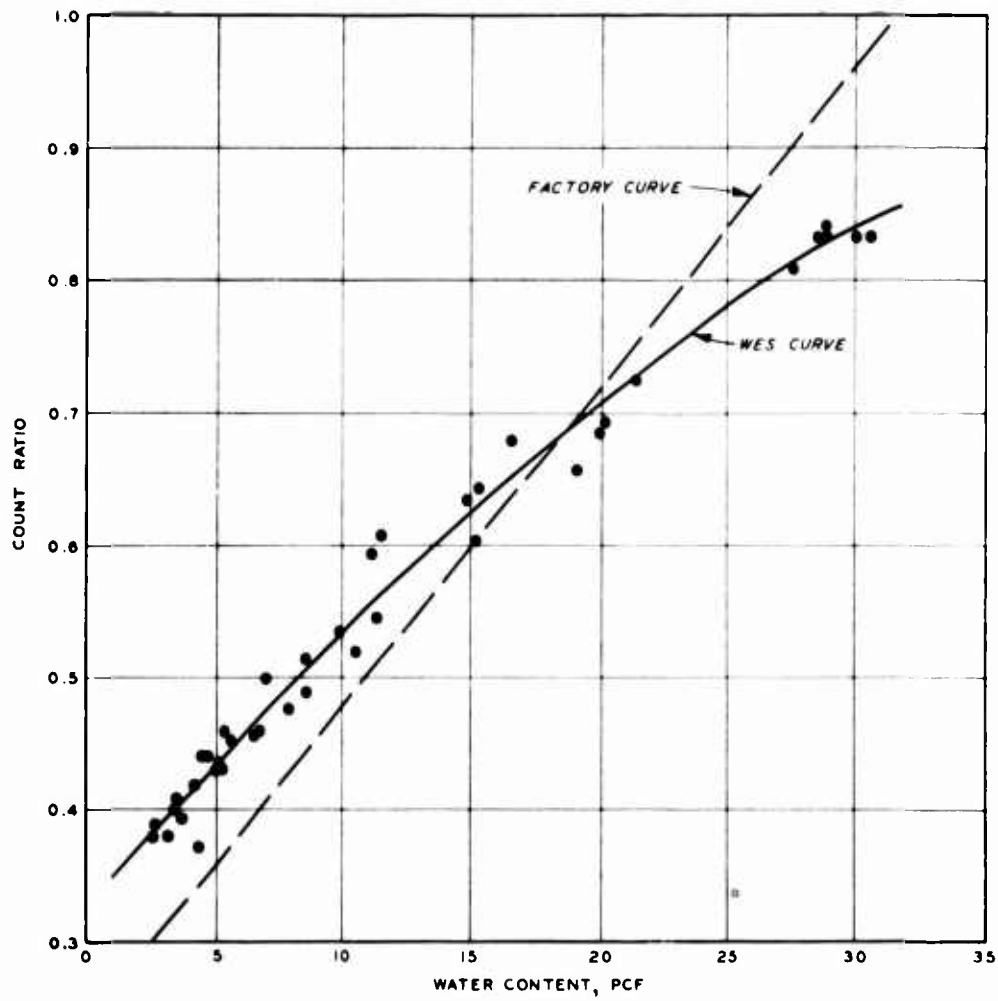

WATER CONTENT
CALIBRATION CURVES

APPENDIX A: TEST PROCEDURE FOR DETERMINING SURFACE LAYER DENSITY AND WATER CONTENT OF SOIL BY NUCLEAR METHODS

EQUIPMENT OPERATION

1. Refer to the instruction manuals supplied by the factory for proper operation of the nuclear equipment.

SAFETY REGULATIONS

2. Conform with the following safety regulations regarding radioactive sources while working with the nuclear equipment.
 - a. Wear film badges at all times.
 - b. Make sure the equipment is leak-tested regularly by qualified personnel.
 - c. Never touch or handle an exposed nuclear source.
 - d. Never remain near the nuclear source longer than necessary while performing soil tests.
 - e. Be sure that the nuclear source is properly shielded when not in use.
 - f. Store the equipment in a proper storage area.

STANDARDIZATION OF EQUIPMENT

3. Take standard counts as follows on the reference standard for water content and for density:
 - a. Set the gauge on the reference standard and position the source in the appropriate water content or density standard count position.
 - b. Set the scaler unit controls in the proper water content or density test positions.
 - c. Allow the equipment to warm up in accordance with the manufacturer's recommendation.
 - d. Take five 1-min readings on the reference standard for density and five 1-min readings for water content at the beginning and at the end of each test day.
 - e. If one reading of a set of five 1-min readings falls outside the limits set by equation A1 below, repeat the five readings. If the second attempt does not satisfy equation A1, the equipment should be checked for possible malfunctions or improper settings and the process repeated.

$$N_s = N_o \pm 2\sqrt{N_o} \quad (A1)$$

where

N_s = range of acceptable readings, counts per min.

N_o = average of a set of five 1-min readings, counts per min.

- f. The average value of the first set of density readings, taken at the beginning of the test day and satisfying equation A1, is the density standard count for the day.
- g. The average value of the first set of water content readings, taken at the beginning of the test day and satisfying equation A1, is the water content standard count for the day.
- h. The set of density and set of water content readings taken at the end of the test day serve as a check on the equipment operation. The averages of these sets of readings should agree with the standard counts obtained at the beginning of the test day if the equipment is operating properly.

TEST SURFACE

4. Prepare the soil surface for testing as follows:
 - a. Level a sufficient area to accommodate the gauge.
 - b. Remove all loose material.
 - c. Fill in any voids with native fines.
 - d. The maximum depressions should not exceed 1/8 in.

METHOD A, SURFACE BACKSCATTER

5. The following test procedure is applicable to water content and wet-density determinations:
 - a. Seat the gauge firmly on the soil surface.
 - b. Place the gauge source in the backscatter position.
 - c. Adjust the scaler unit controls for the appropriate water content or density test.
 - d. Remove all vertical projections within 6 in. of the gauge.
 - e. Check to ensure that no other radioactive sources that will affect the readings are near the gauge.
 - f. Allow the equipment to warm up as in standardization.
 - g. Take three 1-min readings.
 - h. Rotate the gauge either 90 or 180 deg, and take three more 1-min readings.*
 - i. Divide the average of the six (or three) readings by the proper standard count to obtain a count ratio. Determine the wet density or water content by use of the applicable calibration curve.

METHOD B, DIRECT TRANSMISSION

6. The following test procedure is applicable to wet-density determinations:
 - a. Make a hole perpendicular to the prepared soil surface by using a guide provided by the manufacturer.
 - b. Seat the gauge firmly on the soil surface and insert the probe so that the side of the probe facing the center of the gauge is in intimate contact with the side of the hole.
 - c. Adjust the scaler unit controls for density testing.
 - d. Check to ensure that no other radioactive sources that will affect the readings are near the gauge.
 - e. Allow the equipment to warm up as in standardization.
 - f. Take three 1-min readings.
 - g. Rotate the gauge 15 to 20 deg and take three more 1-min readings.*
 - h. Divide the average of the six (or three) readings by the density standard count to obtain a count ratio. Determine the wet density by use of the applicable calibration curve.

* Obtaining additional readings in the rotated position is optional. However, it increases the volume of soil sampled and gives a check on the uniformity of soil water content and density. Therefore, it is recommended if sufficient time is available.

METHOD C, AIR GAP

7. This method of testing is applicable to wet-density determinations.
- a. Complete steps 5a-5i of Method A for density.
 - b. Place the air-gap cradle over the test surface.
 - c. Gently position the gauge in the cradle and set the source in the backscatter position.
 - d. Repeat steps 5c-5i with the gauge in the cradle.
 - e. Determine the air-gap ratio by dividing the average counts per min obtained in 7d by the average counts per min obtained in 7a.
 - f. Determine the wet density by use of the applicable calibration curve.

RESULTS

8. The wet density as determined by the methods above is expressed in pounds per cubic foot and the water content as pounds of water per cubic foot of soil. Equations A2 and A3 below are used to obtain the dry density in pounds per cubic foot and moisture content in percent dry weight.

$$\gamma_{\text{dry}} = \gamma_{\text{wet}} - W \quad (\text{A2})$$

$$W\% = \frac{W}{\gamma_{\text{dry}}} \times 100\% \quad (\text{A3})$$

where

γ_{dry} = dry density, pcf

γ_{wet} = wet density, pcf

W = water content, pcf

W% = water content, percent dry weight

AD 688079

Unclassified

Security Classification

DOCUMENT CONTROL DATA - R & D		
(Security classification of title, body of abstract and indexing annotation must be entered when the overall report is classified)		
1. ORIGINATING ACTIVITY (Corporate author) U. S. Army Engineer Waterways Experiment Station Vicksburg, Mississippi	2a. REPORT SECURITY CLASSIFICATION Unclassified 2b. GROUP	
3. REPORT TITLE EVALUATION OF NUCLEAR METHODS OF DETERMINING SURFACE IN SITU SOIL WATER CONTENT AND DENSITY		
4. DESCRIPTIVE NOTES (Type of report and inclusive dates) Final report		
5. AUTHOR(S) (First name, middle initial, last name) Thomas B. Rosser III Steve L. Webster		
6. REPORT DATE April 1969	7a. TOTAL NO OF PAGES 36	7b. NO OF REFS 7
8a. CONTRACT OR GRANT NO. b. PROJECT NO. 4A024401A891 c. d.	9a. ORIGINATOR'S REPORT NUMBER(S) Miscellaneous Paper S-69-15 9b. OTHER REPORT NO(S) (Any other numbers that may be assigned this report)	
10. DISTRIBUTION STATEMENT This document has been approved for public release and sale; its distribution is unlimited.		
11. SUPPLEMENTARY NOTES	12. SPONSORING MILITARY ACTIVITY Office, Chief of Engineers, U. S. Army Washington, D. C.	
13. ABSTRACT Laboratory tests were conducted to evaluate the accuracy and reliability of measuring surface in situ soil water content and density by the backscatter and direct transmission nuclear methods using a single nuclear device and scaler. The nuclear device functioned as a surface backscatter moisture and density meter or as a direct transmission density probe. To determine the accuracy of the nuclear measurements, it was necessary to know the actual density and water content of the test soil. Boxes were fabricated to exact dimensions, filled with uniformly compacted soil, and weighed, and actual average soil density values were calculated. Five soil types were tested to approximate a full range of possible construction materials. Each soil type was tested at eight different densities and water contents. To obtain comparative results, soil densities of each sample were determined by two accepted conventional methods (sand-cone and water-balloon) for determining density in the field. Test results indicated that in situ densities determined by the direct transmission nuclear method using the factory calibration curve furnished with the device were as accurate as densities obtained by the sand-cone and water-balloon methods. The direct transmission nuclear method using a WES-developed calibration curve provided slightly more accurate density measurements than either conventional method. Densities determined by the surface backscatter nuclear method using both the factory calibration curve and a WES-developed curve were not so accurate as those obtained by the conventional methods. Water contents were obtained by nuclear means and compared with actual water contents determined from oven-dried samples. Using a WES-developed calibration curve, water contents obtained by the nuclear method were sufficiently accurate for most quality control fieldwork. Water contents obtained using the factory calibration curve were not accurate enough for field use. A test procedure for determining surface layer density and water content of soil by nuclear methods is presented in Appendix A.		

DD FORM 1473

REPLACES DD FORM 1473, 1 JAN 60, WHICH IS OBSOLETE FOR ARMY USE.

Unclassified

Security Classification

14 KEY WORDS	LINK A		LINK B		LINK C	
	ROLE	WT	ROLE	WT	ROLE	WT
Measuring instruments Nuclear methods Soil density Soil water content						