

AFOSR 69-1126TR

MARTIN BRAUN

PARTICLE MOTIONS IN A MAGNETIC FIELD

MARCH 1969



PARTICLE MOTIONS IN A MAGNETIC FIELD¹

by

Martin Braun*

Center for Dynamical Systems
Division of Applied Mathematics
Brown University
Providence, Rhode Island

¹This paper was submitted in partial fulfillment of the requirements for the degree of Doctor of Philosophy at New York University.

*This research was supported by the National Aeronautics and Space Administration under Grant No. NGL 40 002-015, and the Air Force Office of Scientific Research under Grant No. AF-AFOSR 693-67.

1. This document has been approved for public release and sale; its distribution is unlimited.

PARTICLE MOTIONS IN A MAGNETIC FIELD

Introduction

The motion of a charged particle in the earth's magnetic field has long been of interest to mathematicians and physicists in connection with the study of the polar aurora and cosmic rays. The mathematical formulation of this problem was given by Störmer as early as 1907; it is often referred to as Störmer's problem. Recently, this problem received renewed significance with the discovery of the Van Allen radiation belt. (see Dragt [6]). This is a region in space that consists of electrically charged particles, which are assumed to be trapped by the earth's magnetic field. Some of these particles were observed to have a lifetime of several years. The purpose of this paper is to rigorously establish the theory of almost periodic motions for the Störmer problem, exhibiting thereby the trapping of charged particles as observed in the Van Allen belt. An additional feature of the theory we shall develop is that it can easily be generalized to any rotationally symmetric "mirror field".

The trajectory of a particle in a magnetic field is generally very complicated and must be obtained by numerical integration of the differential equations of motion. In the special case of a uniform static magnetic field B , the trajectories can be obtained explicitly. As is well known, all particles gyrate in a helix

about the magnetic field lines (see Figure 1).

Figure 1. Particle motions in a constant magnetic field.

If m denotes the mass of the particle, q its charge, v_{\perp} the velocity perpendicular to the magnetic field, and B the magnitude of the magnetic field, then the quantities,

$$M = \frac{mv_{\perp}^2}{2B},$$

$$a = \frac{mv}{qB},$$

are constant along any orbit. M is called the magnetic moment of the particle, and " a " its radius of gyration.

Many mathematicians have concerned themselves with the motion of a charged particle in a slowly varying magnetic field. A slowly varying magnetic field is a field which varies slowly in space and

time - that is, slowly compared with the gyration radius and period. Essentially this means that in the course of one gyration about a magnetic field line, the particle sees an approximately constant field. In a slowly varying field the particle moves approximately in a circle whose center drifts slowly across the lines of force and moves rapidly along the lines. This is the so-called "guiding center" or "adiabatic" approximation. It was shown by Alfvén [1] that the magnetic moment is an adiabatic invariant in a slowly varying field; that is to say, it is constant to first order in the radius of gyration. This result is of extreme importance in plasma physics, where one is interested in confining charged particles in a bounded region. Suppose, for example, that the magnetic field is a convex function along the lines of force. A particle moving along a line of force will be "reflected" backwards at the point P_0 defined by

$$MB(P_0) = E$$

where E is the energy of the particle. Thus, to first order, the guiding center of a particle oscillates periodically along a line of force, between two "mirror" points. In this case it has been shown (Northrop [12]) that the quantity

$$J = \oint P_{\parallel} ds$$

is also an adiabatic invariant, where P_{\parallel} is the guiding center momentum parallel to the lines of force, and the integral is taken over a complete oscillation from one mirror point to the other and back again. J is usually referred to as the longitudinal adiabatic invariant.

However, for virtually every prospective device for the production of useful energy from controlled thermonuclear fission, it was seen that the requirement that the particle remain confined for periods of time encompassing many millions of gyrations could generally be met only if the magnetic moment were constant to a much higher order. In 1955, Hellwig [9] proved the constancy of the magnetic moment to second order in the radius of gyration, and in 1957, Kruskal [10] proved the constancy to all orders. Finally, Gardner [7] showed the constancy of the longitudinal adiabatic invariant to all orders. Moreover, Gardner presented a general method to obtain formal asymptotic expansions for all the adiabatic invariants. The main idea of this paper is to show that the phase space of a particle moving under the influence of the earth's magnetic field contains a region where series, analogous to the formal expansions of Gardner, are actually convergent expansions. This will be accomplished by using a theorem of J. Moser which guarantees the existence of almost periodic solutions of the differential equations of motion.[†] In this manner we will show that

[†]Gardner [8], in 1962, announced a result like ours for particle trajectories in a "mirror" field. To the author's knowledge, a proof of this result was never published by Gardner.

particles which are adiabatically trapped are, in fact, rigorously trapped for all time. This possibility was first pointed out by Arnold [2].

The author wishes to express his deepest gratitude to his thesis advisor, Professor Jürgen K. Moser, for his many helpful hints and suggestions and above all for his patience and understanding while this paper was being written.

1. The Störmer Problem

The earth's magnetic field is assumed here to be equivalent to the field produced by a magnetic dipole situated at the center of the earth. Such a field can be described in cylindrical coordinates ρ, z, ϕ by the equations

$$\begin{aligned}\vec{B} &= \text{curl } \vec{A} \\ \vec{A} &= \frac{M\rho}{r^3} \hat{\phi}\end{aligned}\tag{1.1}$$

$$B = |\vec{B}| = \frac{M}{r^3} (1 + 3 \sin^2 \lambda)^{1/2}$$

(see Figure 2), where M is the moment of the magnetic dipole, which points in the negative z direction, and $\hat{\phi}$ is a unit vector in the ϕ direction. The plane $\lambda = 0$ is the equatorial plane, and the magnetic lines of force are given by

Figure 2.

From the previous discussion one would intuitively expect that the particles with small energy will gyrate about the guiding field line with the (so-called cyclotron) frequency

$$\omega = \frac{qB}{m},$$

where q and m denote the charge and mass of the particle. Moreover, since the field B is a convex function along a line of force, we would expect that the particle, as it moves into regions of stronger field at higher latitudes, will be reflected back toward the equator by converging lines of force. To what extent this is

true will be discussed in the following sections.

To write the differential equations of motion for the Störmer problem, it is most convenient to employ a canonical formulation described by the Hamiltonian

$$H = \frac{1}{2m} [p_\rho^2 + p_z^2 + \left(\frac{p_\phi}{\rho} - qA\right)^2] \quad (1.3)$$

where

$$\begin{cases} p_\rho = m\dot{\rho} \\ p_z = m\dot{z} \\ p_\phi = m\rho^2\dot{\phi} + q\rho A. \end{cases}$$

Since H is independent of time, the energy

$$H = \frac{1}{2}mv^2 = E$$

is a constant of the motion. A second integral of the motion is obtained by noting that H is independent of the angle ϕ . Hence the canonical angular momentum

$$p_\phi = qm\Gamma, \quad (1.4)$$

where Γ is defined by this equation, is a constant of the motion. (The integration constant Γ has the dimensions of a reciprocal

length.) The three dimensional problem is now reduced to the simpler problem of finding the two-dimensional motion of a particle in the $\rho - z$ plane under the influence of the potential

$$V(\rho, z) = \frac{q^2 M^2}{2m} \left(\frac{\Gamma}{\rho} - \frac{\rho}{r^3} \right)^2. \quad (1.5)$$

Once $\rho(t)$ and $z(t)$ have been found, $\phi(t)$ is then determined by integrating the equation

$$\dot{\phi} = -H_{p_\phi}$$

which yields

$$\phi(t) = \phi(0) + \frac{1}{m} \int_0^t \left(\frac{qM\Gamma}{\rho^2} - \frac{qM}{r^3} \right) dt'. \quad (1.6)$$

The sign of Γ plays a crucial role in determining the general properties of trajectories. The radial derivative of V is given by

$$r \cdot \nabla V = \frac{-q^2 M^2}{m} \left(\frac{\Gamma}{\rho} - \frac{\rho}{r^3} \right) \left(\frac{\Gamma}{\rho} - \frac{2\rho}{r^3} \right), \quad (1.7)$$

which is strictly less than zero for Γ negative. A negative radial derivative for the potential corresponds to a repulsive

radial force, since $-r \cdot V$ is the component of the force in the radial direction. Hence all trajectories characterized by a negative Γ must extend to infinity and cannot be trapped. In addition the particle is restricted to lie in the region $V(\rho, z) \leq E$. This region is indicated in Figure 3.

Figure 3. The region $V \leq E$ for $\Gamma < 0$.

Note also that no orbits extend into the dipole ($r = 0$) for Γ negative.

The situation is very similar when $\Gamma = 0$. For ρ unequal to zero the radial derivative of V is again negative. However, $\rho \equiv 0$ is a solution of the equations of motion. Hence the trajectory

$$z(t) = \sqrt{2mE} t + z_0, \quad z_0 < 0$$

runs into the dipole from below the equator, and

$$z(t) = -\sqrt{2mE} t + z_0, \quad z_0 > 0$$

is a trajectory running into the dipole from above the equator. All orbits starting in the shaded region of Figure 4 must extend to infinity.

Figure 4. The region $V \leq E$ for $\Gamma = 0$.

For the study of bounded trajectories, therefore, we restrict ourselves to the case $\Gamma > 0$. It is convenient at this point to introduce the dimensionless variables

$$\left. \begin{aligned} z' &= \Gamma z \\ \rho' &= \Gamma \rho \\ \phi' &= \phi \\ t' &= \frac{\Gamma^3 qM}{m} t \end{aligned} \right\} \quad (1.8)$$

It is easily seen that the equations of motion for these dimensionless variables are derived from the new Hamiltonian

$$H = \frac{1}{2}(p_\rho^2 + p_z^2) + \frac{1}{2}\left(\frac{1}{\rho} - \frac{\rho}{r^3}\right)^2 \quad (1.9)$$

where we have omitted the primes for convenience. In this system of units the particle has the dimensionless velocity

$$w_0 = \frac{1}{4\gamma_1^2},$$

where

$$\gamma_1^4 = \frac{1}{16}\left(\frac{qM}{mv}\right)^2 \Gamma^4. \quad (1.9)'$$

The dimensionless constant γ_1 is that used by Störmer [14].

Note that the angular momentum Γ is now normalized to one.

The potential

$$V(\rho, z) = \frac{1}{2}\left(\frac{1}{\rho} - \frac{\rho}{r^3}\right)^2 \quad (1.10)$$

vanishes along the curve $r = \cos^2 \lambda$, and is positive elsewhere.

(The line of force $r = \cos^2 \lambda$ corresponds in our old coordinates to the line of force $r = \Gamma^{-1} \cos^2 \lambda$.) Since the Hamiltonian H of (1.9) is a constant of the motion, the particle is restricted to

lie in the region $0 \leq V \leq H$. This region assumes three different forms depending on whether H is less than, equal to, or greater than $1/32$.

Figure 5. Allowed region $V(\rho, z) \leq H$ for $H < \frac{1}{32}$.

Figure 6. Allowed region $V(\rho, z) > 1/32$.

Figure 7. Allowed region $V(\rho, z) \leq H$ for $H = \frac{1}{32}$.

From Figure 5 we see that any trajectory starting in the oval like region surrounding the curve $V = 0$ ($r = \cos^2 \lambda$), with initial energy less than $1/32$ can never leave this region for otherwise it would encounter larger values of V . The almost periodic motions we shall find will all lie in this oval like region, where the value of H will be very small. These solutions will gyrate about the line of force $r = \cos^2 \lambda$ and oscillate back and forth across the equator. Furthermore, we shall show that these motions can penetrate arbitrarily close to the dipole, a result which was somewhat unexpected.

One cannot expect to trap particles with $H > 1/32$, since the

region $V \leq H$ extends continuously to infinity. However, for just this reason these solutions are important. Namely, a trajectory cannot extend into the dipole from infinity unless $H > 1/32$. Such trajectories play a role in the theory of the polar aurora (Störmer [14]).

Unfortunately, there are no further known constants of the motion, so that the system of equations derived from the Hamiltonian (1.9) is as simple a system as one can achieve. In general, it has no known explicit solutions. The equations can, however, be solved in terms of elliptic functions for the special initial conditions

$$z = \dot{z} = 0$$

in which case the orbit is confined to the equatorial plane (since the magnetic field is perpendicular to the equatorial plane, and the force $q\vec{v} \times \vec{B}$ is perpendicular to B). The general properties of all equatorial orbits can be obtained by considering the integral curves

$$E = \frac{1}{2}[\dot{\rho}^2 + (\frac{1}{\rho} - \frac{1}{2})^2] \quad (1.11)$$

in the $\rho - \dot{\rho}$ plane (Figure 8). As is to be expected, the shape of the trajectory depends on whether E is less than, equal to, or greater than $1/32$.

Figure 8. Integrals curves in the $\rho - \beta$ plane for equatorial orbits.

For $E > 1/32$ all trajectories run off to infinity, and no periodic solutions exist. For $E = 1/32$, the circle $\rho \equiv 2$ is a periodic orbit (in the $x - y$ plane). Moreover, one trajectory spirals into this circle from within and one from without (Figure 9). For $E < 1/32$ there exist two distinct types of orbits. For $\rho_0 < \rho < 2$, the orbits are all periodic, and for $\rho > 2$, the orbits run off to infinity.

Figure 9. Orbits in the $x - y$ plane spiraling into a periodic orbit, for $E = 1/32$.

Störmer has done extensive work in calculating other families of periodic solutions [14]. A general method to obtain all these periodic motions was presented by De Vogelaere [4]. We shall obtain, as a corollary to our result on the existence of almost periodic solutions, infinitely many periodic solutions, which likewise will lie in the oval like region of Figure 5.

The behavior of the equatorial orbits for small excursions out of the equatorial plane may be examined by perturbation methods. Expanding V as a power series in z and applying Hamilton's equations, one obtains

$$z + \frac{(\rho-1)}{\rho^6} z = 0 + \mathcal{O}(z^3) \quad (1.12)$$

$$\ddot{p} + \frac{1}{\rho^5}(\rho-1)(2-\rho) = 0 + \mathcal{O}(z^2). \quad (1.13)$$

If the terms of second and higher order in z are neglected, the solutions to equation (1.13) are the equatorial orbits, and are therefore known periodic functions of time (for $\rho < 2$, $E < 1/32$). Equation (1.12) then becomes Hill's equation. Its solution can be written in the form

$$z = Ce^{\Omega t} \psi(t) + De^{-\Omega t} \psi(-t) \quad (1.14)$$

where C and D are arbitrary constants and $\psi(t)$ is periodic in time with the same period as $\rho(t)$. The constant Ω , the characteristic Poincaré exponent determines the stability of the orbit. It can be only real or purely imaginary. If Ω is real and $\neq 0$, the motion in the z -direction grows (within the approximation made) without bound. If Ω is purely imaginary the motion is bounded (for time intervals in which the neglected terms have negligible effect) and is therefore stable. The behavior of Ω as a function of γ_1 has been studied by De Vogelaere [5] who finds that all orbits are stable for $\gamma_1 > 1.3137$.

In Section 3, we shall show the existence of a family of two

dimensional invariant tori in the four dimensional phase space of a particle. Any trajectory starting between two such tori can never escape, and will remain trapped between these two tori forever. This is a much stronger result than De Vogelaere's. However, our result is only valid for values of γ_1 much greater than 1.3137.

2. Almost Periodic Motions, Moser's Theorem

(a) We will be concerned in this paper with Hamiltonian systems of two degrees of freedom, and, in particular, with proving the existence of quasi-periodic solutions for systems close to integrable ones.[†] To this end we turn now to the discussion of two geometrical theorems which will be basic for the following. These statements refer to area preserving mappings defined in an annulus in the plane. How the reduction of the differential equations to a mapping can be carried out we will see later on.

To describe an annulus in the plane we use polar coordinates $R = x^2 + y^2$ and the polar angle θ . The annulus is given by

$$1 \leq R \leq 2$$

and the area element by

[†] There is a theorem by Kolmogorov and Arnold [2] guaranteeing the continuation of quasi-periodic motions under small perturbations of the Hamiltonian. However, this theorem does not quite apply to our case since the second frequency ω_2 will be small. For this singular case we resort to Moser's theorem.

$$dx dy = \frac{1}{2} dR d\theta.$$

At first we consider a simple type of mapping which we shall call a "twist mapping" M_0 :

$$R_1 = R$$

$$\theta_1 = \theta + \gamma(R)$$

which clearly preserves the area element as well as concentric circles $R = \text{constant}$. Each of these circles is rotated by an angle $\gamma(R)$, which, in general, depends on the radius. It will be a basic assumption for the following that $\gamma(R)$ is not a constant, or, more precisely, that

$$\frac{d\gamma}{dR} \neq 0 \text{ in } 1 \leq R \leq 2. \quad (2.1)$$

The properties of this mapping are easily understood. Each circle $R = \text{constant}$ for which $\gamma/2\pi = p/q$ is rational consists of fixed points of M_0^q . Each circle for which γ and 2π are incommensurable is densely covered by the images of the iterates M_0^q ($q = 1, 2, \dots$) of any point on this circle.

Our main objective will be to discuss a mapping M which is close to the twist mapping M_0 . Therefore, we consider a mapping M_ϵ

$$\begin{aligned} R_1 &= R + \epsilon f(R, \theta, \epsilon) \\ \theta_1 &= \theta + \gamma(R) + \epsilon g(R, \theta, \epsilon) \end{aligned} \tag{2.2}$$

where f, g are assumed to have the period 2π in θ . This mapping is defined in the annulus $1 \leq R \leq 2$ but need not map this annulus into itself.

Theorem (Poincaré-Birkhoff). Let $\gamma'(R) \neq 0$ and let M_ϵ be area preserving for all ϵ in the sense that

$$\int_C R d\theta = \int_{MC} R d\theta^\dagger$$

for any closed curve C . Given any rational number p/q between $2\pi\gamma(1)$ and $2\pi\gamma(2)$ there exist $2q$ fixed points of M_ϵ^q satisfying

$$\begin{aligned} R_q &= R \\ \theta_q &= \theta + 2\pi p \end{aligned}$$

provided ϵ is sufficiently small.

This theorem is actually a very simple version of the celebrated

[†]For simplicity we write M in place of M_ϵ .

and much deeper fixed point theorem by Poincaré and Birkhoff in which no smallness assumption is required. The present theorem is a consequence of the implicit function theorem. One sees immediately that the q^{th} iterate of M has the form

$$R_q = R + \mathcal{O}(\epsilon)$$

$$\theta_q = \theta + q\gamma(R) + \mathcal{O}(\epsilon)$$

and -- by the implicit function theorem -- there is a unique $R = F(\theta, \epsilon)$ satisfying

$$\theta_q = \theta + 2\pi p$$

for sufficiently small ϵ . This solution $R = F(\theta, \epsilon)$ represents a starlike curve C which is mapped "radially" by M^q , since θ_q and θ differ by an integral multiple of 2π . Since the mapping M and hence M^q preserves the area $\int_C R d\theta$ it follows that C and the image curve $M^q C$ intersect in at least two points. These points are clearly the desired fixed points. If P is one fixed point, $MP, \dots, M^{q-1}P$ provide $q - 1$ further fixed points and the theorem is proven.

It is important to observe that we had a continuum of fixed points of M^q for $\epsilon = 0$ while for $\epsilon > 0$ we predict only a finite number of fixed points. In fact, it can be shown by examples that in general the curve of fixed points breaks up into a finite set

of fixed points.

Now we turn to the question of what happens under perturbation to those circles $R = \text{constant}$ for which $\gamma(R)/2\pi$ is irrational. This is the content of the following theorem which will not be proven here.

Theorem (Moser [11]). Let $\gamma'(R) \neq 0$ and let any curve C surrounding $R = 1$ and its image curve MC intersect each other. The functions f, g are assumed to be sufficiently often differentiable. Then, for sufficiently small ϵ there exists an invariant curve Γ surrounding $R = 1$. More precisely, given any number ω between $\gamma(1)$ and $\gamma(2)$ incommensurable with 2π , and satisfying the inequalities

$$\left| \frac{\omega}{2\pi} - \frac{p}{q} \right| \geq c|q|^{-5/2}$$

for all integers p, q , and some constant $c > 0$, there exists a differentiable closed curve

$$\begin{aligned} R &= F(\phi, \epsilon) \\ \theta &= \phi + G(\phi, \epsilon) \end{aligned} \tag{2.3}$$

with F, G of period 2π in ϕ , which is invariant under the mapping M_ϵ -- provided ϵ is sufficiently small. The image point of a point on the curve (2.3) is obtained by replacing

ϕ by $\phi + \omega$.

In actual fact this theorem provides not only one but infinitely many invariant curves. We observe that the intersection property for curves mentioned in the above theorems is certainly satisfied if the area $\int_C R d\theta$ is preserved. Namely, if C is any curve surrounding $R = 1$ so will the image curve surround $R = 1$. If the curves C and MC would not intersect each other one of them would lie inside the other and the areas $\int_C R d\theta$ and $\int_{MC} R d\theta$ could not agree.

For later applications we need an extension of the previous theorem: If the mapping (2.2) is replaced by

$$\left. \begin{aligned} R_1 &= R + \epsilon^\sigma f(R, \theta, \epsilon) \\ \theta_1 &= \theta + \alpha + \epsilon^\rho \gamma(R) + \epsilon^\sigma g(R, \theta, \epsilon) \end{aligned} \right\} \quad (2.4)$$

where $0 \leq \rho < \sigma$, then the conclusions of the previous theorems remain true. The essential point is that the perturbation term is small compared to the "twist" $\epsilon^\rho \gamma(R)$.

To apply Moser's theorem to prove the existence of invariant tori for a Hamiltonian system of two degrees of freedom, we first approximate the Hamiltonian H , (if possible) by an integrable Hamiltonian H_0 ; i.e. we write

$$H = H_0(R_1, R_2, \epsilon) + \epsilon^k H_1(R_1, \theta_1, R_2, \theta_2, \epsilon) \quad (2.5)$$

where $\omega_1 = \partial H_0 / \partial R_1$ is of order one, and the frequency ratio ω_2 / ω_1 varies over a region of order ϵ^k with $k < 1$ ($\omega_2 = \partial H_0 / \partial R_2$). On the energy surface $H = c$ we solve for

$$R_1 = \Phi(R_2, \theta_1, \theta_2). \quad (2.6)$$

Using θ_1 as independent variable instead of t and setting $R_2 = R$, $\theta_2 = \theta$, we find from Hamilton's equations that

$$\frac{dR}{d\theta_1} = \frac{-H_\theta}{H_{R_1}}; \quad \frac{d\theta}{d\theta_1} = \frac{H_R}{H_{R_1}}. \quad (2.7)$$

One verifies easily that on $H = c$ these equations take the form

$$\frac{dR}{d\theta_1} = \Phi_\theta; \quad \frac{d\theta}{d\theta_1} = -\Phi_R \quad (2.7)'$$

where Φ is defined in (2.6).

The system (2.7) is again Hamiltonian, of one degree of freedom, but non-autonomous. To eliminate the independent variable we follow the solutions from $\theta_1 = 0$ to the next intersection with $\theta_1 = 2\pi$. This defines a mapping which -- by Liouville's Theorem -- preserves the area $\int R d\theta$. This mapping will have the form

$$\begin{aligned} R(2\pi) &= R(0) + \mathcal{O}(\epsilon^k) \\ \theta(2\pi) &= \theta(0) + \alpha + \epsilon^k \gamma(R) + \mathcal{O}(\epsilon^k) \end{aligned} \quad (2.8)$$

with $\gamma'(R) \neq 0$. Note that the condition $\gamma'(R) \neq 0$ means that the frequency ratio ω_2/ω_1 varies on the energy surface $H = c$. The important point is that the frequency ratio varies over a region which is large compared to ϵ^l , i.e. the twist $\epsilon^k \gamma(R)$ is small compared to the neglected terms. Moser's Theorem guarantees infinitely many invariant curves of the mapping (2.8), for sufficiently small ϵ . Any curve invariant under this mapping generates an invariant torus if we take all solutions which issue forth from the invariant curve, and on these tori, the motion is quasi-periodic with two frequencies.

In this case a quasi-periodic motion will densely cover a two dimensional invariant torus in the four dimensional phase space of the particle. Any trajectory starting between two such tori must always remain between these two tori. (Warning: This is not true for $n > 2$.) This provides a powerful tool for proving the stability of periodic orbits. In the following section we shall show the existence of quasi-periodic motions in the earth's magnetic field which lie near the equator. All trajectories near the equator which are caught between two such tori must remain near the equator forever. This is the stability result for "near equatorial" orbits which we mentioned in the preceding section.

(b) We would now like to show how one goes about approximating H to higher and higher order by an integrable Hamiltonian. The method we shall present is known as the Lindstedt method [13].

For simplicity we shall restrict ourselves to systems with two degrees of freedom.

Consider a Hamiltonian H of the form

$$H_1 = \omega_1 x_1 + \omega_2 x_2 + \epsilon H_1(x_1, x_2, y_1, y_2) + \epsilon^2 H_2 + \dots \quad (2.9)$$

where x_i is conjugate to y_i and H has period 2π in y_1 and y_2 , i.e.

$$H(x, y_i + 2\pi) = H(x, y_i).$$

We would like to find new canonical variables x'_i, y'_i so that H will be independent of the angular variables y'_1, y'_2 through terms of order n . To this end we consider a generating function of the form

$$S = y_1 x'_1 + y_2 x'_2 + \epsilon S_1(x'_1, x'_2, y_1, y_2) + \epsilon^2 S_2 + \dots \quad (2.10)$$

with

$$x_i = \frac{\partial S}{\partial y_i}, \quad y'_i = \frac{\partial S}{\partial x'_i}. \quad (2.10)'$$

If we denote the Hamiltonian H expressed in terms of the primed variables by

$$\bar{H}(x', y') = \omega_1 x'_1 + \omega_2 x'_2 + \epsilon \bar{H}_1(x'_1, x'_2) + \epsilon^2 \bar{H}_2 + \dots \quad (2.11)$$

then from (2.10)

$$H(x'_1 + \epsilon \frac{\partial S_1}{\partial y_1} + \dots, x'_2 + \epsilon \frac{\partial S_1}{\partial y_2} + \dots, y_1, y_2) = \bar{H}. \quad (2.12)$$

Equating terms of order ϵ in (2.12) we see that

$$\omega_1 \frac{\partial S_1}{\partial y_1} + \omega_2 \frac{\partial S_1}{\partial y_2} = \bar{H}_1(x'_1, x'_2) - H_1(x'_1, x'_2, y_1, y_2). \quad (2.13)$$

In order for S_1 to be periodic in y_1 and y_2 we must require that the right hand side of (2.13) have mean value zero. Hence

$$\bar{H}_1(x'_1, x'_2) = \frac{1}{(2\pi)^2} \int_0^{2\pi} \int_0^{2\pi} H_1(x'_1, x'_2, y_1, y_2) dy_1 dy_2 \quad (2.14)$$

i.e. \bar{H}_1 is the mean value of H_1 . We still cannot solve for S_1 since a Fourier series expansion will contain the small divisors $j_1 \omega_1 + j_2 \omega_2$. We therefore require that the frequencies satisfy the infinitely many inequalities

$$|(j, \omega)| \geq \gamma |j|^{-\tau} \quad (2.15)$$

for all integers j_1, j_2 with $|j| = |j_1| + |j_2| > 0$, and with some constants γ and $\tau > 1$. If the right hand side of (2.13) has the Fourier expansion

$$\cdot \sum_{k \neq 0} a_k(x') e^{i(k,y)}$$

then S_1 is given by

$$S_1 = \sum_{k \neq 0} \frac{a_k(x')}{i(k,\omega)} e^{i(k,y)} .$$

To determine S_k we note that equating terms of order k in (2.12) yields

$$\omega_1 \frac{\partial S_k}{\partial y_1} + \omega_2 \frac{\partial S_k}{\partial y_2} = H_k + G_k - H_k \quad (2.16)$$

where G_k depends only on $S_i, H_i, 0 \leq i \leq k-1$. Thus H_k is determined by setting the mean value of the right hand side of (2.16) equal to zero, and then S_k is determined. To eliminate the y dependence of H through order n , we simply truncate the series for S after $\epsilon^n S_n$.

The above method may be extended to the case where the lowest order term H_0 of H is given by

$$H_0 = H_0(x_1, x_2).$$

We simply choose $x' = x^0$ so that

$$\omega_1 = \frac{\partial H_0(x^0)}{\partial x_1}$$

are rationally independent numbers satisfying (2.15), and then restrict the variables x' to a small neighborhood

$$|x' - x^0| = \mathcal{O}(\epsilon^{n+1}).$$

Finally, if the frequency ω_2 is zero to lowest order, we first eliminate the y_1 dependence of H through order n . Then, if we can find new variables so that \bar{H}_1 is also independent of y_2 , we may eliminate the y_2 dependence through order n .

3. Main Result. Existence of Quasi-Periodic Motions

(a) In this section we will prove the existence of quasi-periodic solutions of the Störmer problem. These motions will all lie in the oval like region of Figure 5 and will satisfy $H \ll 1/32$. Moreover, these motions may penetrate arbitrarily close to the dipole.

(b) Dipolar coordinates. Since our intuitive idea of the motion is a gyration about a line of force and an oscillation along the line of force, it is natural to introduce new "orthogonal" coordinates $a(\rho, z)$, $b(\rho, z)$ such that the curve $a(\rho, z) = \text{const.}$ defines a magnetic line of force. The magnetic field lines are given by the equation

$$a = \frac{r}{\cos \lambda}, \quad (a = \text{const.}). \quad (3.1)$$

From the equation

$$\frac{\partial a}{\partial \rho} \frac{\partial b}{\partial \rho} + \frac{\partial a}{\partial z} \frac{\partial b}{\partial z} = 0 \quad (3.2)$$

we find that

$$b(\rho, z) = \frac{\sin \lambda}{r^2}. \quad (3.3)$$

(Any function of b together with a provide an orthogonal coordinate system.) The new canonical variables may be obtained from the generating function

$$F(\rho, z, p_a, p_b) = a(\rho, z)p_a + b(\rho, z)p_b \quad (3.4)$$

by employing the standard relations

$$\left. \begin{aligned} a &= \frac{\partial F}{\partial p_a} = a(\rho, z); & p_\rho &= \frac{\partial F}{\partial \rho} = \frac{\partial a}{\partial \rho} p_a + \frac{\partial b}{\partial \rho} p_b \\ b &= \frac{\partial F}{\partial p_b} = b(\rho, z); & p_z &= \frac{\partial F}{\partial z} = \frac{\partial a}{\partial z} p_a + \frac{\partial b}{\partial z} p_b \end{aligned} \right\} \quad (3.5)$$

In terms of these new variables the Hamiltonian H of (1.9) takes the form

$$H(a, p_a, b, p_b) = \frac{1}{2} \left(\frac{p_a^2}{h_a^2} + \frac{p_b^2}{h_b^2} \right) + \frac{(a-1)^2}{2a \cos^6 \lambda} \quad (3.6)$$

where

$$h_a^2 = \frac{\cos^6 \lambda}{1+3\sin^2 \lambda}, \quad h_b^2 = \frac{a^6 \cos^{12} \lambda}{1+3\sin^2 \lambda}. \quad (3.7)$$

It is understood that $\sin \lambda$ and $\cos \lambda$ are to be expressed in terms of a and b .

We now wish to restrict ourselves to a region in phase space where the energy H will be small. This is to conform with our notion that in the course of one gyration about its guiding field line, the particle should see an approximately constant magnetic field. Thus we consider the change of variables

$$\begin{aligned} a - 1 &= \epsilon^2 \alpha & b &= \epsilon \beta \\ p_a &= \epsilon^2 p_\alpha & p_b &= \epsilon^3 p_\beta \end{aligned} \quad (3.8)$$

where ϵ is a small parameter. The condition $a - 1 = \epsilon^2 \alpha$ means that we require the particle to remain near the guiding field line $r = \cos^2 \lambda$. Our system will remain Hamiltonian if we take

$$H(\alpha, \beta, p_\alpha, p_\beta) = H/\epsilon^4. \quad (3.9)$$

Our next step is to try and approximate H by an integrable

Hamiltonian. To this end we first show that $\lambda(a,b)$ is an analytic function of a and b for b small. Squaring equation (3.1) and multiplying by (3.3) yields

$$a^2 b = \frac{\sin \lambda}{(1 - \sin^2 \lambda)^2}. \quad (3.10)$$

The derivative of the right hand side of equation (3.10) with respect to λ is one at $\lambda = 0$. Therefore, we are guaranteed that $\lambda(a,b)$ is an analytic function of $z = a^2 b$ for $|z|$ small.

Hence, we may write

$$\begin{aligned} \sin^2 \lambda &= \epsilon^2 \beta^2 + 4\epsilon^4 (\alpha\beta^2 - \beta^4) + G_1(\alpha, \beta, \epsilon) \\ \cos^{-6} \lambda &= 1 + 3\epsilon^2 \beta^2 + 6\epsilon^4 (2\alpha\beta^2 - \beta^4) + G_2(\alpha, \beta, \epsilon) \end{aligned} \quad (3.11)$$

where G_i can be written in the form $\epsilon^6 \bar{G}_i(\alpha, \beta, \epsilon)$ with \bar{G}_i analytic in the variables α, β, ϵ . These expansions are trivially derived from the relation

$$a^4 b^2 = \frac{\sin^2 \lambda}{(1 - \sin^2 \lambda)^4}. \quad (3.12)$$

The Hamiltonian (3.9) may now be written in the form

$$H = H_0 + H_2 + H_4 + H_6 \quad (3.13)$$

where

$$H_0 = \frac{\alpha^2 + p_\alpha^2}{2}$$

$$H_2 = \frac{\epsilon^2}{2} (6\beta^2 p_\alpha^2 - 4\alpha^3 + p_\beta^2 + 3\beta^2 \alpha^2)$$

$$H_4 = \frac{3\epsilon^4}{2} (24\alpha\beta^2 p_\alpha^2 - 3\beta^4 p_\alpha^2 - 2\alpha p_\beta^2 + 3\beta^2 p_\beta^2 + 2\alpha^4 - 2\alpha^2 \beta^4)$$

and

$$H_6 = \epsilon^6 \bar{H}_6(\alpha, \beta, p_\alpha, p_\beta, \epsilon)$$

with \bar{H}_6 analytic in all its variables.

We shall now show that $H_0 + H_2 + H_4$ can be transformed into an integrable Hamiltonian, modulo terms of order ϵ^6 . Firstly, define new coordinates R, θ via the formula

$$\alpha = \sqrt{2R} \sin\theta, \quad p_\alpha = \sqrt{2R} \cos\theta. \quad (3.14)$$

From their definition, R and θ are canonical coordinates. The magnetic moment M of the particle will be proportional to $\epsilon^4 R$ (to be shown in Section 4). Note also that $H_0 = R$, and R is constant to order ϵ^2 . Next, we employ Lindstedt's method to average out the θ dependence of H to order ϵ^6 , i.e. we define new variables $R', \theta', \beta', p_\beta'$ so that H is independent of θ'

through order ϵ^4 . The frequency ω_2 of (2.9) is zero, while $\omega_1 = 1$. In the notation of Section 2,

$$\bar{H}_2 = \frac{1}{2\pi} \int_0^{2\pi} H_2 d\theta = \frac{\epsilon^2}{2} [9R'(\beta')^2 + (p'_\beta)^2] \quad (3.15)$$

and

$$\bar{H}_4 = \frac{1}{2\pi} \int_0^{2\pi} [H_4 + \epsilon^2 \frac{\partial H_2}{\partial R} \frac{\partial S_2}{\partial \theta} + \epsilon^2 \frac{\partial H_2}{\partial p_\beta} \frac{\partial S_2}{\partial \beta} - \epsilon^2 \frac{\partial H_2}{\partial R} \frac{\partial S_2}{\partial p_\beta}] d\theta. \quad (3.16)$$

The generating function $S_2 = S_2(R', \theta, \beta, p'_\beta)$ is given by

$$S_2 = -\frac{1}{2} \left[\frac{3\beta^2 R'}{2} \sin 2\theta - 4(2R')^{3/2} \left(-\cos \theta + \frac{\cos^3 \theta}{3} \right) \right]. \quad (3.17)$$

Performing the integration in (3.16) we find that the Hamiltonian (3.13) may be written in the form

$$H = H_0 + H_2 + H_4 + H_6 \quad (3.18)$$

where

$$H_0 = R$$

$$H_2 = \frac{\epsilon^2}{2} (9R\beta^2 + p_\beta^2)$$

$$H_4 = \frac{\epsilon^4}{2} (9\beta^2 p_\beta^2 - 21R^2 - \frac{69R\beta^4}{4}).$$

(we have suppressed the primes for convenience), and $H_6 = O(\epsilon^6)$.

For fixed R the curves

$$9R\beta^2 + p_\beta^2 = \text{const.}$$

are ellipses in the β, p_β plane. These curves may be transformed into circles (with the same area) by the generating function

$$F(\theta, \beta, R_1, p'_\beta) = (9R_1)^{1/4} \beta p'_\beta + \theta R_1. \quad (3.19)$$

Setting

$$\beta' = \sqrt{2R_2} \sin \theta_2, \quad p'_\beta = \sqrt{2R_2} \cos \theta_2 \quad (3.20)$$

we see that H_2 is independent of θ_2 . Hence, we may employ the Lindstedt method to average out the θ_2 dependence of H to order ϵ^6 . In terms of new canonical variables which we again call $R_1, \theta_1, R_2, \theta_2$, the Hamiltonian H now assumes the form

$$H = R_1 + 3\epsilon^2 R_2 \sqrt{R_1} + \frac{\epsilon^4}{2} (-21R_1^2 + \frac{13R_2^2}{8}) + H_6 \quad (3.21)$$

where $H_6 = \epsilon^6 \bar{H}_6(R_1, R_2, \theta_1, \theta_2, \epsilon)$, with \bar{H}_6 analytic in all its variables. Thus, we have succeeded in approximating H by an

integrable Hamiltonian

$$F = H - H_6$$

to order ϵ^6 . We now apply Moser's Theorem to prove the continuation of quasi-periodic motions under the perturbation H_6 . As described in Section 2, we solve for $R_1 = \phi(R_2, \theta_1, \theta_2, \epsilon)$ on the energy surface $H = c$, and take θ_1 instead of t as independent variable. We then follow the solutions from $\theta_1 = 0$ to their next intersection with $\theta_1 = 2\pi$. This defines an area preserving mapping which we denote by M . Since

$$\frac{d\theta_2}{d\theta_1} = \frac{H_{R_2}}{H_{R_1}} = 3\epsilon^2 \sqrt{R_1} - \frac{23}{8} \epsilon^4 R_2 + \mathcal{O}(\epsilon^6) \quad (3.22)$$

and

$$R_1^{1/2} = c^{1/2} - \frac{3\epsilon^2 R_2}{2} + \mathcal{O}(\epsilon^4), \quad (3.22)'$$

the mapping M has the form, in the coordinates $R = R_2, \theta = \theta_2$,

$$\begin{aligned} \tilde{R} &= R(2\pi) = R + \epsilon^6 f(R, \theta, \epsilon) \\ M: \quad \tilde{\theta} &= \theta(2\pi) = \theta + 3\epsilon^2 c^{1/2} - \frac{59}{8} \epsilon^4 R + \epsilon^6 g(R, \theta, \epsilon) \end{aligned} \quad (3.23)$$

where $R = R(0)$, $\theta = \theta(0)$ and f, g are analytic in the variables R, θ, ϵ . This mapping is of the form (2.4) with $\rho = 4$, $\sigma = 6$, and

$$\gamma'(R) = -\frac{59}{8} \neq 0.$$

Hence, Mcser's Theorem applies.

Thus, we have established the existence of quasi-periodic motions with two frequencies for sufficiently small ϵ . Since we restricted b to be small, all these motions must lie near the equatorial plane. Moreover, these motions gyrate tightly about the guiding field line $r = \cos^2 \lambda$ (or $r = \Gamma^{-1} \cos^2 \lambda$ in our old coordinates). A typical motion is illustrated in Figure 10.

Figure 10. A quasi-periodic motion in the $\rho - z$ plane.

These orbits all cross the magnetic field line at an angle near 90° since the velocity of the particle parallel to the magnetic field is much smaller than the total velocity. This follows from the fact that $p_b = \epsilon^3 p_\beta$ is of third order small while $p_a = \epsilon^2 p_\alpha$ is only of second order.

(c) Quasi-periodic motions which penetrate arbitrarily close to the dipole.

Our goal now is to prove the existence of quasi-periodic motions which need not lie near the equatorial plane. To this end we consider, instead of (3.8) the change of coordinates

$$\begin{aligned} a - 1 &= \epsilon\alpha ; b = \epsilon\beta \\ p_a &= \epsilon p_\alpha ; p_b = \epsilon p_\beta \end{aligned} \tag{3.24}$$

where again ϵ denotes a small parameter. Let M and N be two fixed constants, with N very large. We then consider all variables to be complex, and restrict ourselves to the region T defined by

$$\begin{aligned} |\alpha| + |p_\alpha| + |p_\beta| &\leq M \\ |\operatorname{Re} b| &\leq N \\ |\operatorname{Im} b| &\leq \delta(M, N, \epsilon) \end{aligned} \tag{3.25}$$

where δ depends on M, N , and ϵ and will be chosen so that the Hamiltonian (3.6) is analytic in the variables a, b, p_a, p_b in the region T , for ϵ sufficiently small. To find the singularities of H in the complex 4-space we consider again the equation (3.10)

$$a^2 b = \frac{\sin \lambda}{(1 - \sin^2 \lambda)^2}.$$

With $z = a^2 b$ and $y = \sin \lambda(a, b)$, we observe that

$$\frac{dz}{dy} = \frac{1 + 3y^2}{(1 - y^2)^3}. \quad (3.26)$$

Hence the only singular points are $y = \pm 1$, $y = \pm \frac{1}{\sqrt{3}}$. It is

clear that for fixed M and N , δ may be chosen so that $\sin \lambda \neq \pm 1$ for $|\operatorname{Im} b| \leq \delta$, and ϵ sufficiently small. The points $y = \pm 1/\sqrt{3}$ correspond to the points

$$z = a^2 b = \pm i \frac{3\sqrt{3}}{16}.$$

Letting $a^2 = a_1 + ia_2$, $b = b_1 + ib_2$, we see that

$$a^2 b = a_1 b_1 - a_2 b_2 + i(a_1 b_2 + a_2 b_1). \quad (3.27)$$

For fixed N and N , we now restrict δ and ϵ still further so that

$$|a_1 b_2 + a_2 b_1| \leq \frac{3}{16}$$

thus excluding the points $z = \pm \frac{i3\sqrt{3}}{16}$. The new Hamiltonian

$$H(\alpha, p_\alpha, \beta, p_\beta, \epsilon) = \frac{1}{\epsilon} H(a, b, p_a, p_b) = \frac{1}{2} \left(\frac{p_\alpha^2}{h_a^2} + \frac{p_\beta^2}{h_b^2} \right) + \frac{\alpha^2}{2(1+\epsilon\alpha)^4 \cos^6 \lambda} \quad (3.28)$$

is now analytic in all variables in the region T . Note that although N is fixed, it may be chosen as large as desired. The points $(a = 1 + \epsilon\alpha, b = N)$ all lie very close to the dipole, and approach the dipole as $N \rightarrow \infty$.

(d) Our next task is to approximate the Hamiltonian by an integrable one. We cannot expand H in powers of $\epsilon\alpha$ and $\epsilon\beta$ as we did previously, since now $\beta \sim 1/\epsilon$. Instead we expand H in powers of $(a-1) = \epsilon\alpha$ only. Since $\sin \lambda$ and \cos^{-1} are analytic in T we may write

$$\begin{aligned} 1 + 3 \sin^2 \lambda &= K_1(b) + F_1(a, b) \\ \cos^{-6} \lambda &= C_1(b) + F_2(a, b) \end{aligned} \quad (3.29)$$

where $F_1(a,b) = \mathcal{O}((a-1))$. ($\mathcal{O}((a-1)^k)$ denotes an analytic function which vanishes, together with its first $k-1$ derivatives with respect to a , at $a=1$.) The Hamiltonian (3.28) may thus be written in the form

$$H = H_0 + H_1 \quad (3.30)$$

where

$$H_0 = \frac{c_1}{2}(K_1 p_\alpha^2 + \alpha^2) + \frac{K_1 c_1^2}{2} p_\beta^2 \quad (3.30)'$$

and $H_1 = \epsilon \bar{H}_1(\alpha, \epsilon\beta, p_\alpha, p_\beta, \epsilon)$, with \bar{H}_1 analytic in all its variables. The arguments of the functions c_1 and K_1 are $b = \epsilon\beta$.

(e) The next logical step is to transform the Hamiltonian H_0 into an integrable one, modulo terms of order ϵ . We start by finding new variables α', p'_α so that H_0 is a function of $(\alpha')^2 + (p'_\alpha)^2$ alone. These variables may be obtained from the generating function

$$F(\alpha, \beta, p'_\alpha, p'_\beta) = K_1^{-1/4} \alpha p'_\alpha + \frac{f p'_\beta}{\epsilon} \quad (3.31)$$

where the arguments of the functions K_1 and f are $\epsilon\beta$. It would suffice (for the purpose stated above) to take $f = \epsilon\beta$. However, a judicious choice of f will enable us to express H_0

explicitly, and thereby simplify most of the later calculations.

The new canonical variables $\alpha', p'_\alpha, \beta', p'_\beta$ are determined from the relations

$$p_\alpha = \frac{\partial F}{\partial \alpha} = K_1^{-1/4} p'_\alpha; \quad \beta' = \frac{\partial F}{\partial p'_\beta} = \frac{f}{\epsilon} \quad (3.32)$$

$$\alpha' = \frac{\partial F}{\partial p'_\alpha} = K_1^{-1/4} \alpha; \quad p_\beta = \frac{\partial F}{\partial \beta} = f^{(1)} p'_\beta - \frac{\epsilon}{4} K_1^{-1/4} K_1^{(1)} \alpha p'_\alpha$$

where $K_1^{(1)}$ and $f^{(1)}$ denote the derivatives of the functions K_1 and f with respect to $b = \epsilon\beta$.

A point in the $\rho - z$ plane is determined from the coordinates α', β' in the following manner: Given α' and β' , the point lies on the magnetic field line $r = a \cos^2 \lambda$, where

$$a = 1 + \epsilon \alpha' [1 + 3(\epsilon \beta')^2]^{1/4}. \quad (3.33)$$

The coordinate b on this magnetic field line is then found from the relation

$$f(b) = f(\epsilon \beta') = \epsilon \beta'. \quad (3.34)$$

We cannot solve (3.34) exactly for b . However, for the f we shall determine it will be seen that as $\epsilon \beta'$ increases (decreases) to $+1(-1)$, b increases (decreases) to $+\infty(-\infty)$; and that the

latitude λ , for $a = 1$, is precisely

$$\sin^{-1}(\epsilon\beta').$$

Thus, $\beta'(t)$ essentially describes the motion along a line of force, for the coordinate a near one. In terms of the primed variables the Hamiltonian (3.30) assumes the form

$$H = \frac{c_1\sqrt{K_1}}{2}[(\alpha')^2 + (p'_\alpha)^2 + c_1\sqrt{K_1}(f')^2(p'_\beta)^2] + H_1, \quad (3.35)$$

with $H_1 = \mathcal{O}(\epsilon)$.

(f) We shall now show that the Hamiltonian H_0 is an integrable Hamiltonian, i.e. we shall find new canonical coordinates R, θ, J, ϕ so that $H_0 = H_0(R, J)$. To this end we define canonical coordinates R, θ in place of α', p'_α by the relations

$$\alpha' = \sqrt{2R} \sin\theta, \quad p'_\alpha = \sqrt{2R} \cos\theta. \quad (3.36)$$

H_0 is now independent of θ . Hence the coordinate R , which we shall later show (see Section 4) is proportional to M/ϵ^2 , is a constant of the motion to lowest order in ϵ . To lowest order, $\dot{\theta}$ is given by the equation

$$\dot{\theta} = \omega_1 = c_1\sqrt{K_1}. \quad (3.37)$$

But the quantity on the right hand side of (3.37) is the magnitude of the magnetic field along the line of force $r = \cos^2 \lambda$ (see (1.1), (1.2) and (3.29)). Thus, we have confirmed our intuitive notion that to lowest order the particle gyrates about its guiding field line with the cyclotron frequency ω_1 .

It is convenient at this point to introduce a new time scale τ so that the frequency ω_1 becomes one, i.e. the particle gyrates about its guiding field line in the new time scale with constant frequency. This is easily accomplished by setting

$$\tau = \int \omega_1 dt. \quad (3.38)$$

Our trajectories are now the zero energy solutions of the Hamiltonian

$$F = \frac{1}{\omega_1} (H-h) = F_0 + F_1 \quad (3.39)$$

where h is the constant value of the Hamiltonian (3.35) and

$$F_0 = R + \frac{1}{2\omega_1} (\omega_1^2 (f')^2 (p'_\beta)^2 - 2h) \quad (3.39)'$$

$$F_1 = \frac{H_1}{\omega_1}.$$

Thus, to lowest order we have decoupled the motion in α', p'_α and in β', p'_β . This puts into evidence the integrability of the truncated system.

In this approximation the motion in the β', p'_β plane is described by the Hamiltonian

$$\phi = \frac{1}{2\omega_1} (f')^2 (p'_\beta)^2 - \frac{h}{\omega_1} \quad (3.40)$$

which we now calculate. For this purpose we observe that $\omega_1 = C_1 \sqrt{K_1}$ and f' all are expressed in terms of $f(b) = f(\epsilon\beta) = \epsilon\beta'$ if we define $f(b)$ by

$$b = \frac{f}{(1-f^2)^2}. \quad (3.41)$$

Therefore, ϕ can be expressed in explicit algebraic form. To show this write

$$\sin \lambda = f_1(b) + \mathcal{O}((a-1))$$

where we have $f_1 = f$ (see $a^2 b = \frac{\sin \lambda}{(1-\sin^2 \lambda)^2}$). Then compute

$$\omega_1 = \frac{\sqrt{1+3\gamma^2}}{(1-\gamma^2)^3} \text{ with } \gamma = \epsilon\beta'$$

and

$$f' = \frac{(1-f^2)^3}{1+3f^2} = \frac{(1-\gamma^2)^3}{1+3\gamma^2} = \frac{1}{\omega_1 \sqrt{1+3\gamma^2}}.$$

Hence

$$\phi = \frac{1}{2\omega_1} \left[\frac{(p'_\beta)^2}{1+3\gamma^2} - 2h \right] = \frac{(1-\gamma^2)^3}{2\sqrt{1+3\gamma^2}} \left[\frac{(p'_\beta)^2}{1+3\gamma^2} - 2h \right]. \quad (3.42)$$

The motion in the β', p'_β plane derived from the Hamiltonian F_0 is qualitatively determined by considering the level curves (see Figure 11)

$$c = \frac{-h(1-\gamma^2)^3}{(1+3\gamma^2)^{1/2}} + \frac{1}{2} \frac{(1-\gamma^2)^3}{(1+3\gamma^2)^{3/2}} (p'_\beta)^2 \quad (3.43)$$

in the β', p'_β plane. For $c > 0$ these curves are not closed and asymptotically approach the lines $\gamma = \pm 1$. The curves corresponding to $c = 0$ are hyperbolas defined by

$$\frac{1}{2}(p'_\beta)^2 - 3h\gamma^2 = h. \quad (3.44)$$

Figure 11. Level curves in the γ, p'_β plane of $\phi = \text{const.}$

For $c < 0$, the components of these curves in $|\gamma| < 1$ are all closed, and lie inside the domain bounded by $\gamma = \pm 1$ and the hyperbole, with the point s in Figure 11 determined from the equation

$$-\frac{h}{c} = \frac{(1+3s^2)^{1/2}}{(1-s^2)^{3/2}}. \quad (3.45)$$

The quasi-periodic orbits obtained previously correspond to small oscillations in the β', p'_β plane about the equilibrium corresponding to equatorial orbits. Since we are only considering the zero energy solutions of F , the constant c is essentially $-R$. Hence $\beta'(\tau)$ and $p'_\beta(\tau)$ will be periodic functions of τ if we neglect the term F_1 in (3.39). Thus we have justified our intuitive idea that the guiding center of a particle oscillates along a line of force between two mirror points. This motion is indicated schematically in Figure 12. To lowest order, the particle mirrors at a latitude $\lambda = \sin^{-1}s$ where

$$\frac{h}{R} = \frac{(1+3s^2)^{1/2}}{(1-s^2)^{3/2}}. \quad (3.46)$$

Figure 12. Schematic description of guiding center motion.

Thus, the smaller R , the closer the particle approaches the dipole. It is also clear from Figure 11 and the discussion concerning the coordinates α', β' that there exist orbits of the unperturbed system F_0 in the region $|b| \leq N$ which achieve $|b| > 3N/4$.

Finally, since the curves (3.43) are closed for $c < 0$, we may introduce the familiar action-angle variables J, ϕ in place of β', p'_β , where the action J is given by

$$J = \frac{4\sqrt{2}}{\epsilon} \int_0^{\pi} \left\{ h(1+3x^2) + \frac{c(1+3x^2)^{3/2}}{(1-x^2)^2} \right\}^{1/2} dx. \quad (3.47)$$

(J is simply the area of the closed curves (3.43) in the β', p'_β plane.) In terms of the variables R, θ, J, ϕ the Hamiltonian F_0 takes the form

$$F_0 = R + c(\epsilon J). \quad (3.48)$$

Thus, we have succeeded in showing that the Hamiltonian F_0 is integrable. The two frequencies of motion determined by F_0 are

$$\begin{aligned} \omega_1 &= \frac{\partial F_0}{\partial R} = 1 \\ \omega_2 &= \frac{\partial F_0}{\partial J} = \epsilon c' \end{aligned} \quad (3.49)$$

where c' denotes the derivative of c with respect to ϵJ . Incidentally, the fact that ω_2 is proportional to ϵ is in agreement with our notion that the particle oscillates slowly along a line of force, while gyrating rapidly about it. Note also that the action J , which is the longitudinal adiabatic invariant divided by ϵ^2 , is constant to lowest order.

We now apply Moser's Theorem to prove the existence of quasi-periodic motions for the full Hamiltonian

$$F = R + c(\epsilon J) + \epsilon F_1(R, \epsilon J, \theta, \phi, \epsilon) \quad (3.50)$$

where F_1 is analytic in all its variables. On the energy surface

$F = 0$ we solve for $R = \Phi(\epsilon J, \theta, \phi, \epsilon)$ and take θ instead of t as independent variable. We then follow the solutions from $\theta = 0$ to their next intersection with $\theta = 2\pi$. This defines a mapping M , which in the coordinates $r = \epsilon J, \phi$ is given by

$$\begin{aligned} r_1 &= r(2\pi) = r + \epsilon^2 f(r, \phi, \epsilon) \\ M: \quad \phi_1 &= \phi(2\pi) = \phi + \epsilon c'(r) + \epsilon^2 g(r, \phi, \epsilon) \end{aligned} \quad (3.51)$$

with f, g analytic in all its arguments. The intersection property of a curve with its image curve still holds, trivially. Hence, the above mapping M is of the form (2.4) with $\rho = 1, \sigma = 2$ and

$$\gamma(r) = c'(r). \quad (3.52)$$

To apply Moser's Theorem now, we need only verify the condition

$$\gamma'(r) = c''(r) \neq 0 \quad (3.53)$$

i.e. $\gamma(r)$ should be a monotonic function of r . Unfortunately, we cannot calculate $\gamma(r)$ explicitly and must be content with numerical calculations. Figure 13 below shows the graph of $\gamma(r)$ versus c . It is clear that $\gamma(r)$ has a single stationary point at $c = -.70$. At this point the non-degeneracy condition (3.53) is violated.

Figure 13. Graph of $\gamma(r)$ versus c .

Thus, with the exception of one point, Moser's Theorem guarantees the existence of quasi-periodic motions, close to the unperturbed motion defined by the Hamiltonian F_0 , for sufficiently small ϵ . Since some of the unperturbed motions achieved $|b| > 3N/4$, then for sufficiently small ϵ there will exist quasi-periodic motions for the full Hamiltonian which achieve $|b| > N/2$. By choosing N arbitrarily

large these quasi-periodic motions can penetrate arbitrarily close to the dipole. Of course, the larger we choose N , the smaller we must take ϵ , i.e. the tighter the particle gyrates about its guiding field line.

We now wish to schematically describe these quasi-periodic motions in coordinate space, rather than phase space. In the $\rho - z$ plane, the particle is confined to the oval like region in Figure 5, with V very small, and it rotates slowly around the z -axis in accordance with the equation

$$\phi(t) = \int \left(\frac{1}{\rho} - \frac{\rho}{r^3} \right) dt' + \text{const.} \quad (3.54)$$

It will be shown in the following section that the quantity p_b^2/h_b^2 in (3.6) is $v_{||}^2$, where $v_{||}$ is the velocity of the particle parallel to the magnetic field. To lowest order in ϵ we then have

$$\frac{v_{||}^2}{v_{\perp}^2} = -1 + \frac{h}{R} \frac{[1 - (\epsilon R')^2]^3}{[1 + 3(\epsilon R')^2]}. \quad (3.55)$$

For R small, the particle crosses the equatorial plane ($\beta' = 0$) at an angle near 90° . As $\epsilon R'$ increases to its maximum value s , the quantity $v_{||}^2/v_{\perp}^2$ decreases monotonically to zero. When the particle crosses the field line $r = \cos^2 \lambda$, $\dot{\lambda} = 0$, and hence the velocity vector lies in the meridian ($\rho - z$) plane. Thus, the

particle crosses the guiding field line in a sequence of angles which monotonically approach 90° . This situation is illustrated in Figure 14.

Figure 14.

As the particle moves back toward the equator, the crossing angles begin to decrease monotonically, until the particle is moving nearly parallel to the field at the equator. Note that as the particle moves into regions of high latitude, it begins to gyrate rapidly, since the cyclotron frequency becomes large.

(g) As a corollary to the above result on the existence of quasi-periodic motions, we are automatically guaranteed infinitely many

periodic solutions. We outline the proof briefly. Each quasi-periodic motion densely covers a two dimensional invariant torus in the four dimensional phase space of the particle. Moreover, this torus must lie on the energy surface $H = \text{const.}$ We now cut the torus with a surface of section S , and consider the mapping $P \rightarrow M(P)$ induced on S by the differential equations; i.e. $M(P)$ is the point where the trajectory beginning at P returns to S . From the form of the Hamiltonian F of (3.53), it is possible to introduce coordinates R, θ on S so that the mapping M has the form

$$M: \begin{aligned} R_1 &= R + \epsilon^2 f(R, \theta, \epsilon) \\ \theta_1 &= \theta + \epsilon \gamma(R) + \epsilon^2 g(r, \theta, \epsilon). \end{aligned}$$

A mapping M of this form is referred to as a "twist" mapping, and the Poincaré-Birkhoff fixed point theorem (Birkhoff [3]) guarantees the existence of at least two fixed points. Since each fixed point represents a periodic solution, we have established the existence of infinitely many periodic solutions to the Störmer problem (which also lie in the oval-like region 5, with H very small).

4. Quasi-Periodic Motions in a Rotationally Symmetric Magnetic "Mirror" Field.

(a) We consider now a rotationally symmetric magnetic field B , i.e. a field which is independent of the azimuthal angle ϕ .

The motion of a charged particle in such a field can be described by a Hamiltonian of the form

$$H(\rho, z, p_\rho, p_z) = \frac{1}{2}(p_\rho^2 + p_z^2) + \frac{1}{2}\left(\frac{\Gamma}{\rho} - A(\rho, z)\right)^2, \quad (4.1)$$

where we have normalized the mass and charge to be one, and Γ is the constant electromagnetic angular momentum of the particle. The magnetic field \vec{B} may be determined from the equation

$$\vec{B} = \nabla \times \vec{A} \quad (4.2)$$

with

$$\vec{A} = A(\rho, z)\hat{\phi}.$$

The components of \vec{B} in the ρ and z directions are then

$$\begin{aligned} B_\rho &= -\frac{\partial A}{\partial z} \\ B_z &= \frac{1}{\rho} \frac{\partial}{\partial \phi}(\rho A). \end{aligned} \quad (4.3)$$

We make the following assumptions on the magnetic field B :

- (i) The field strength is a convex function along a segment S of a magnetic field line l .

- (ii) The potential $A(\rho, z)$ is an analytic function of ρ and z in a neighborhood T of S .
- (iii) The magnetic field is unequal to zero on S .

Under the assumptions (i-iii) we shall prove the existence of quasi-periodic motions in T .

(b) The main step in our proof is to transform the Hamiltonian (4.1) into a Hamiltonian of the same form as (3.6). This is accomplished with the aid of the following Lemma.

Lemma: The magnetic lines of force are given by the equations

$$\rho A(\rho, z) = c = \text{const.} \quad (4.4)$$

Proof: The vector

$$\vec{n} = \left(\frac{c}{\rho^2} + \frac{\partial A}{\partial \rho} \right) \hat{\rho} + \frac{\partial A}{\partial z} \hat{z} \quad (4.5)$$

is perpendicular to the curve

$$A(\rho, z) - \frac{c}{\rho} = 0. \quad (4.6)$$

From (4.3) we may write

$$\vec{B} = - \frac{\partial A}{\partial z} \hat{\rho} + \frac{1}{\rho} \frac{\partial}{\partial \rho} (\rho A) \hat{z}. \quad (4.7)$$

Hence,

$$\vec{n} \cdot \vec{B} = \left(\frac{c}{\rho^2} + \frac{\partial A}{\partial \rho} \right) \left(-\frac{\partial A}{\partial z} \right) + \left(\frac{A}{\rho} + \frac{\partial A}{\partial \rho} \right) \frac{\partial A}{\partial z} = \left(\frac{c}{\rho^2} - \frac{A}{\rho} \right) \frac{\partial A}{\partial z}$$

which vanishes along the curve $A(\rho, z) = c$. Thus, $\vec{n} \cdot \vec{B} = 0$, and the curves (4.4) coincide with the magnetic field lines.

Since by (iii) the magnetic field does not vanish in a neighborhood of S , we may introduce orthogonal coordinates $a(\rho, z)$, $b(\rho, z)$ such that the curves $a(\rho, z) = \text{const.}$ define a magnetic line of force. By the preceding lemma we may take

$$a(\rho, z) = \rho A(\rho, z). \quad (4.8)$$

The coordinate $b(\rho, z)$ is then determined from the equation

$$\frac{\partial a}{\partial \rho} \frac{\partial b}{\partial \rho} + \frac{\partial a}{\partial z} \frac{\partial b}{\partial z} = 0. \quad (4.9)$$

To effect a canonical transformation we use the generating function

$$F(a, b, p_a, p_b) = a(\rho, z) p_a + b(\rho, z) p_b, \quad (4.10)$$

and the Hamiltonian (4.1) assumes the form

$$H(a, b, p_a, p_b) = \frac{1}{2} (h_a^2 p_a^2 + h_b^2 p_b^2) + \frac{1}{2} \frac{(\Gamma - a)^2}{\rho^2} \quad (4.11)$$

(6)

where

$$h_a^2 = \left(\frac{\partial a}{\partial \rho}\right)^2 + \left(\frac{\partial a}{\partial z}\right)^2 \quad (4.11)'$$

$$h_b^2 = \left(\frac{\partial b}{\partial \rho}\right)^2 + \left(\frac{\partial b}{\partial z}\right)^2$$

and the coordinates ρ, z are assumed to be expressed in terms of a and b . As mentioned in the previous section, the quantity $h_b^2 p_b^2$ is v_u^2 . To prove this, note that

$$\begin{aligned} v_u &= \frac{\vec{v} \cdot \vec{B}}{B} = \frac{(p_\rho \hat{\rho} + p_z \hat{z})}{B} \cdot \frac{1}{\rho} \left(-\frac{\partial a}{\partial z} \hat{\rho} + \frac{\partial a}{\partial \rho} \hat{z}\right) \\ &= \frac{\left(-\frac{\partial a}{\partial z} p_\rho + \frac{\partial a}{\partial \rho} p_z\right)}{\left[\left(\frac{\partial a}{\partial \rho}\right)^2 + \left(\frac{\partial a}{\partial z}\right)^2\right]^{1/2}} \end{aligned}$$

by virtue of (4.3) and (4.8). But

$$\frac{\partial a}{\partial z} p_z - \frac{\partial a}{\partial \rho} p_\rho = \left(\frac{\partial a}{\partial \rho} \frac{\partial b}{\partial z} - \frac{\partial a}{\partial z} \frac{\partial b}{\partial \rho}\right) p_b.$$

Hence

$$\begin{aligned} v_u^2 &= \frac{p_b^2}{\left(\frac{\partial a}{\partial \rho}\right)^2 + \left(\frac{\partial a}{\partial z}\right)^2} \left[\left(\frac{\partial a}{\partial \rho}\right)^2 \left(\frac{\partial b}{\partial z}\right)^2 + \left(\frac{\partial a}{\partial z}\right)^2 \left(\frac{\partial b}{\partial \rho}\right)^2 - \right. \\ &\quad \left. - 2 \frac{\partial a}{\partial \rho} \frac{\partial a}{\partial z} \frac{\partial b}{\partial \rho} \frac{\partial b}{\partial z} \right] \end{aligned}$$

$$\begin{aligned}
&= \frac{p_b^2}{\left(\frac{\partial a}{\partial \rho}\right)^2 + \left(\frac{\partial a}{\partial z}\right)^2} \left[\left(\frac{\partial a}{\partial \rho}\right)^2 \left(\frac{\partial \rho}{\partial t}\right)^2 + \left(\frac{\partial a}{\partial z}\right)^2 \left(\frac{\partial z}{\partial t}\right)^2 + \right. \\
&\qquad\qquad\qquad \left. + \left(\frac{\partial a}{\partial \rho}\right)^2 \left(\frac{\partial \rho}{\partial t}\right)^2 + \left(\frac{\partial a}{\partial z}\right)^2 \left(\frac{\partial z}{\partial t}\right)^2 \right] \\
&= \left[\left(\frac{\partial a}{\partial \rho}\right)^2 + \left(\frac{\partial a}{\partial z}\right)^2 \right] p_b^2 \\
&= h_b^2 p_b^2.
\end{aligned}$$

(c) The Hamiltonian (4.11) is now very similar to (3.6) and we proceed in the same manner as in Section 3. Our first step is to consider only those particles with angular momentum Γ for which the magnetic line of force

$$a(\rho, z) = \rho A(\rho, z) = \Gamma$$

coincides with the field line l . (Of course, if the magnetic field is convex along every field line, then no restrictions are placed on Γ .) As in the previous section we consider only those trajectories which stay near the guiding field line $a(\rho, z) = \Gamma$, and which have small energy. Thus, we take

$$a - \Gamma = \epsilon \alpha$$

$$p_a = \epsilon p_\alpha$$

$$b = \epsilon \beta$$

$$p_b = \epsilon p_\beta$$

with $|\alpha|$, $|p_\alpha|$, $|p_\beta|$ bounded and ϵ sufficiently small so that h_a^2 , h_b^2 , and ρ^2 are analytic functions of a and b . The new Hamiltonian has the form

$$H(\alpha, \beta, p_\alpha, p_\beta) = \frac{1}{\epsilon} H = \frac{1}{2} (h_a^2 p_\alpha^2 + h_b^2 p_\beta^2) + \frac{\alpha^2}{2\rho^2}. \quad (4.12)$$

To approximate H by an integrable Hamiltonian we write

$$\begin{aligned} h_a^2 &= a_1(b) + \mathcal{O}((a-1)) \\ h_b^2 &= b_1(b) + \mathcal{O}((a-1)) \\ \frac{1}{\rho^2} &= c_1(b) + \mathcal{O}((a-1)). \end{aligned} \quad (4.13)$$

The Hamiltonian (4.12) may then be written in the form

$$H = H_0 + H_1 \quad (4.14)$$

where

$$H_0 = \frac{a_1}{2} p_\alpha^2 + \frac{c_1}{a_1} \alpha^2 + \frac{b_1}{2} p_\beta^2 \quad (4.14)'$$

and $H_1 = \epsilon \bar{H}_1(\alpha, \epsilon\beta, p_\alpha, p_\beta, \epsilon)$, with \bar{H}_1 analytic in all its variables. The arguments of a_1, b_1 , and c_1 are $b = \epsilon\beta$.

Our next step is to introduce new variables α', p'_α in place of α, p_α so that H_c is a function of $(\alpha')^2 + (p'_\alpha)^2$ alone. This is accomplished by taking the generating function

$$F(\alpha, \beta, p'_\alpha, p'_\beta) = K_1 \alpha p'_\alpha + \beta p'_\beta$$

where $K_1 = c_1/a_1$. In terms of the new variables H_0 assumes the form

$$H_0 = \sqrt{a_1 c_1} \left[\frac{(\alpha')^2 + (p'_\alpha)^2}{2} \right] + \frac{b_1}{2} (p'_\beta)^2. \quad (4.15)$$

Setting $\alpha' = \sqrt{2R} \sin \theta$, $p'_\alpha = \sqrt{2R} \cos \theta$, we note that to first order in ϵ , R is constant and

$$\dot{\theta} - \omega_1 = \sqrt{a_1 c_1}. \quad (4.16)$$

The quantity $\epsilon^2 R$ is the magnetic moment M , and ω_1 is the cyclotron frequency B evaluated along the magnetic field line λ .

To prove this recall that

$$a_1 = \left(\frac{\partial a}{\partial \rho} \right)^2 + \left(\frac{\partial a}{\partial z} \right)^2 \Big|_{a=R}$$

$$c_1 = \frac{1}{\rho^2} \Big|_{a=R}.$$

Hence

$$\begin{aligned}\omega_1^2 &= a_1 c_1 = \frac{1}{\rho^2} \left(\frac{\partial a}{\partial \phi} \right)^2 + \frac{1}{\rho^2} \left(\frac{\partial a}{\partial z} \right)^2 \\ &= \left(\frac{\partial A}{\partial z} \right)^2 + \left(\frac{A}{\rho} + \frac{\partial A}{\partial \phi} \right)^2 \\ &= B^2.\end{aligned}$$

Since $\epsilon^2 b_1 p_\beta^2 = v_1^2$ to lowest order, it now follows immediately that

$$R = \frac{\epsilon^2 v_1^2}{2B}$$

to lowest order.

Again we change the time scale so that the frequency ω_1 becomes 1; our trajectories are then the zero energy solutions of the Hamiltonian

$$F = \frac{1}{\omega_1} (H - h) \quad (4.17)$$

where h is the constant value of the Hamiltonian H . The lowest order term F_0 of F is now given by

$$F_0 = R + \frac{b_1 (p_\beta')^2}{2} - \frac{h}{\omega_1}, \quad (4.18)$$

where the arguments of b_1 and ω_1 are $\epsilon\beta'$.

To determine the motion in the β', p'_β plane to lowest order, i.e. to determine the motion along the guiding field line l , we consider the level curves

$$\frac{b_1(p'_\beta)^2}{2\omega_1} - \frac{h}{\omega_1} = c \quad (4.19)$$

in the β', p'_β plane. Under the assumption that $\omega_1 = B$ is a convex function, these curves will be closed for

$$B_{\min} < -\frac{h}{c} \sim \frac{E}{M} < B_{\max} \quad (4.20)$$

where B_{\min} and B_{\max} are defined in Figure 15 below, and E is the energy of the particle. To show this simply write the curves (4.19) in the form

$$(p'_\beta)^2 = \frac{2}{b_1}(h + c\omega_1). \quad (4.19)'$$

Hence the motion along l will be periodic for c, h satisfying (4.20). The region outside (4.20) is usually referred to as the "loss cone" of the particle, since one cannot hope to trap particles in that region.

Figure 15.

Finally, we introduce action angle variables J, ϕ in place of β', p'_β (for c satisfying (4.20)). The Hamiltonian F now may be written in the form

$$F = R + c(\epsilon J) + \epsilon F_1(R, \epsilon J, \theta, \phi, \epsilon) \quad (4.21)$$

where F_1 is analytic in all its variables. This is exactly the situation we encountered for the dipole field. It remains to check the non-degeneracy condition

$$c''(r) \neq 0$$

with $r = \epsilon J$. This is something which must be checked for each magnetic field. Moser's Theorem will then guarantee quasi-periodic motions in the region $c''(r) \neq 0$. These motions densely cover two dimensional invariant tori in the four dimensional phase space of the particle. Moreover, any trajectory starting between two such tori can never escape. Hence all particles which are adiabatically trapped are, in fact, rigorously trapped for all time. Note also that the argument in the preceding section concerning the existence of infinitely many periodic solutions is carried over exactly to the more general case.

(d) To conclude this section, we would like to show the impossibility of trapping charged particles in a "planar" magnetic field, i.e. a field whose magnitude and direction do not depend on the coordinate z . A particle moving in such a field can be described by the Hamiltonian

$$H(x, y, z, p_x, p_y, p_z) = \frac{1}{2}[p_x^2 + p_y^2 + (p_z - A(x, y))^2]. \quad (4.23)$$

The quantity p_z is a constant of the motion since $\partial A / \partial z \equiv 0$. We may now apply our method to get quasi-periodic motions in the $x - y$ plane. The motion in the z -direction is then found by integrating the equation

$$\dot{z} = p_z - A(x(t), y(t)). \quad (4.24)$$

However, even if $x(t)$ and $y(t)$ are quasi-periodic functions, we cannot expect $z(t)$ to be quasi-periodic. In fact, the mean value of $A(x(t), y(t))$ need not be p_z , in which case the motion in the z -direction will definitely be unbounded.

BIBLIOGRAPHY

- [1] Alfvén, H., Cosmical Electrodynamics, (Clarendon Press, Oxford, 1950).
- [2] Arnold, V.I., Small divisor and stability problems in classical and celestial mechanics, *Uspekhi Mat. Nauk*, 18, No. 6 (114), pp. 85-191, 1963.
- [3] Birkhoff, G.D., Proof of Poincaré's geometric theorem, *Trans. Amer. Math. Society*, Vol. 14, pp. 14-22, January 1913.
- [4] De Vogelaere, R., On the structure of symmetric periodic solutions of conservative systems, with applications, *Contributions to the Theory of Nonlinear Oscillations*, Princeton University Press, pp. 53-84, 1958.
- [5] De Vogelaere, R., L'Equation de Hill et le problème de Störmer, *Can. J. Math.*, 2, 440, 1950.
- [6] Dragt, A.J. Trapped orbits in a magnetic dipole field, *Reviews of Geophysics*, 3, pp. 255-298, 1965.
- [7] Gardner, C.S., The adiabatic invariants of periodic classical systems, *Phys. Rev.* 115, pp. 791-794, 1959.
- [8] Gardner, C.S., On the containment for infinite times of particles in a mirror machine, A.E.C. Research and Development Report, NYO-10424, New York University, 1962.
- [9] Hellwig, G., "Über die Bewegung geladener Teilchen in schwach veränderlicher Magnetfeldern, *Zeits Naturforschung*, 10a, pp. 508-516, 1955.
- [10] Kruskal, M., *Rendiconti del Terzo Congresso Internazionale sui Fenomeni D'Ionezzazione nei Gas Tenuto a Venezia*, Società Italiana di Fisica, Milan, 1957.

BIBLIOGRAPHY (CONT'D.)

- [11] Moser, J., On invariant curves of area-preserving mappings of an annulus, Nachr. Akad. Wiss., Göttingen: Math. Phys. Kl. IIa, Nr. 1, pp. 1-20, 1962.
- [12] Northrop, T.G., (The Adiabatic Motion of Charged Particles,) Interscience, New York, 1963.
- [13] Poincaré, H., Methodes Nouvelle de la Mécanique Céleste, Vol. 2, Chap. 9, (Paris: Gauthier-Villars, 1893).
- [14] Stormer, C., The Polar Aurora, (Clarendon Press, Oxford, 1955).

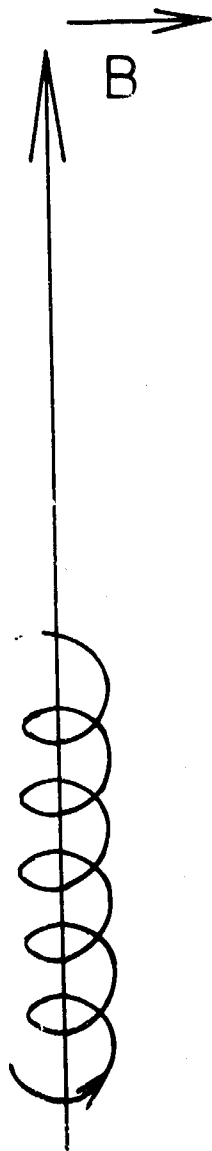

FIG. 1

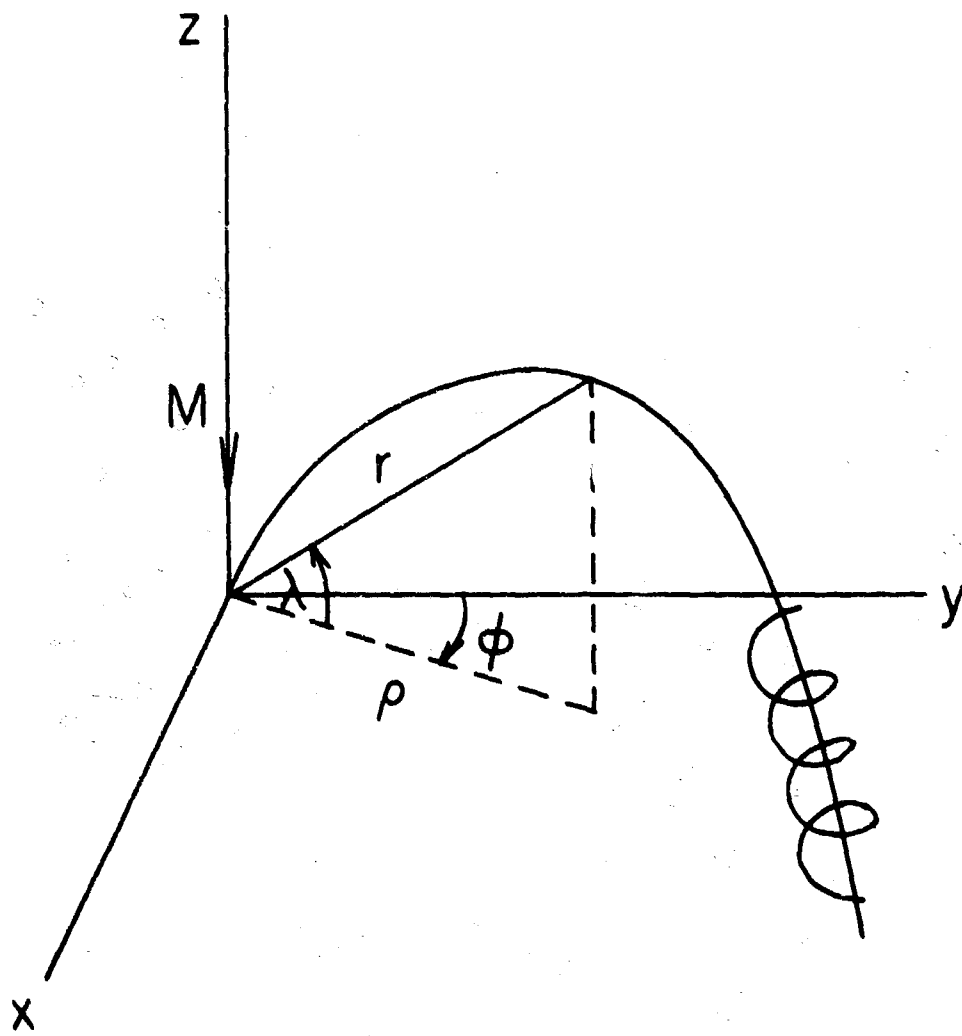

FIG. 2

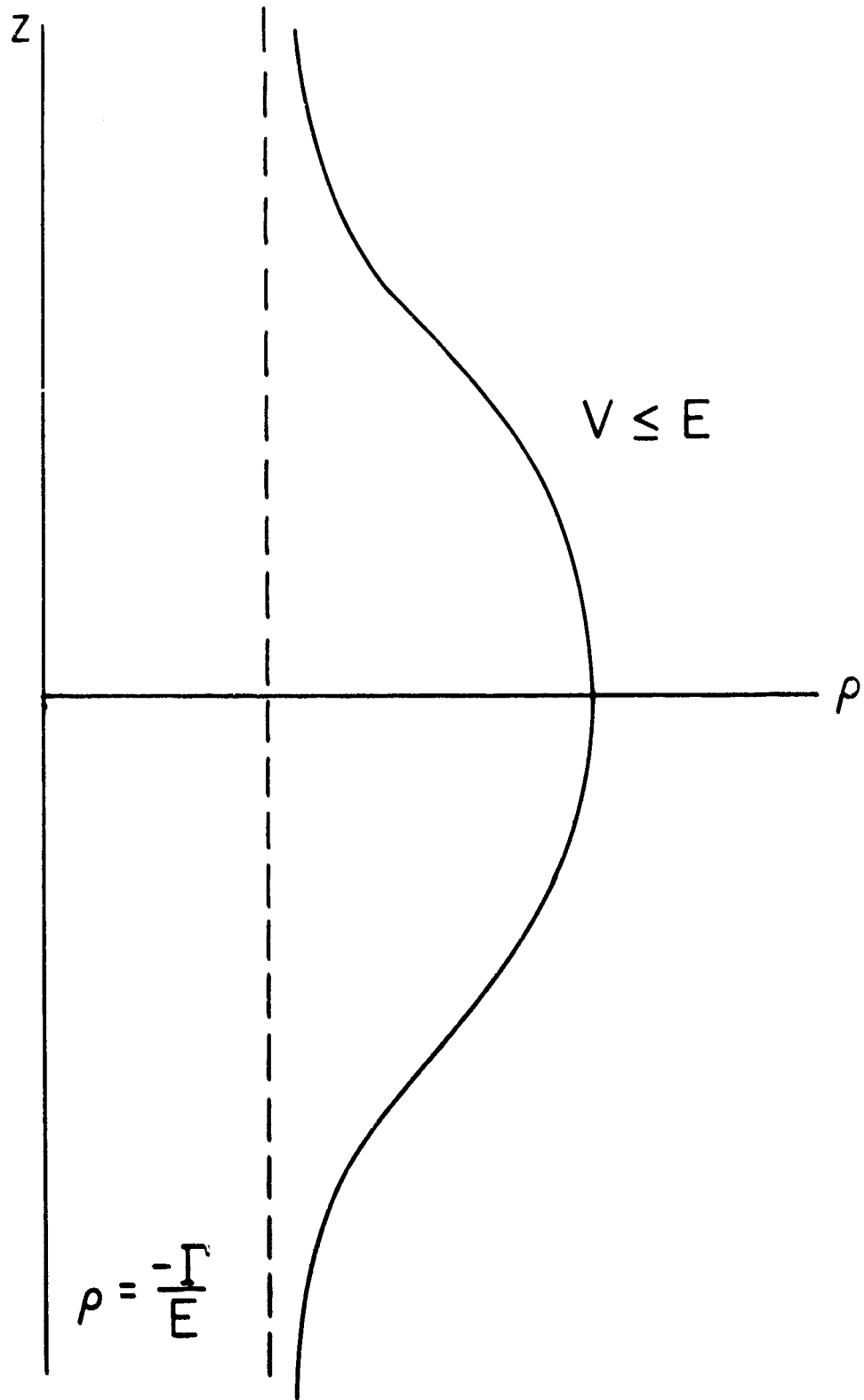

FIG. 3

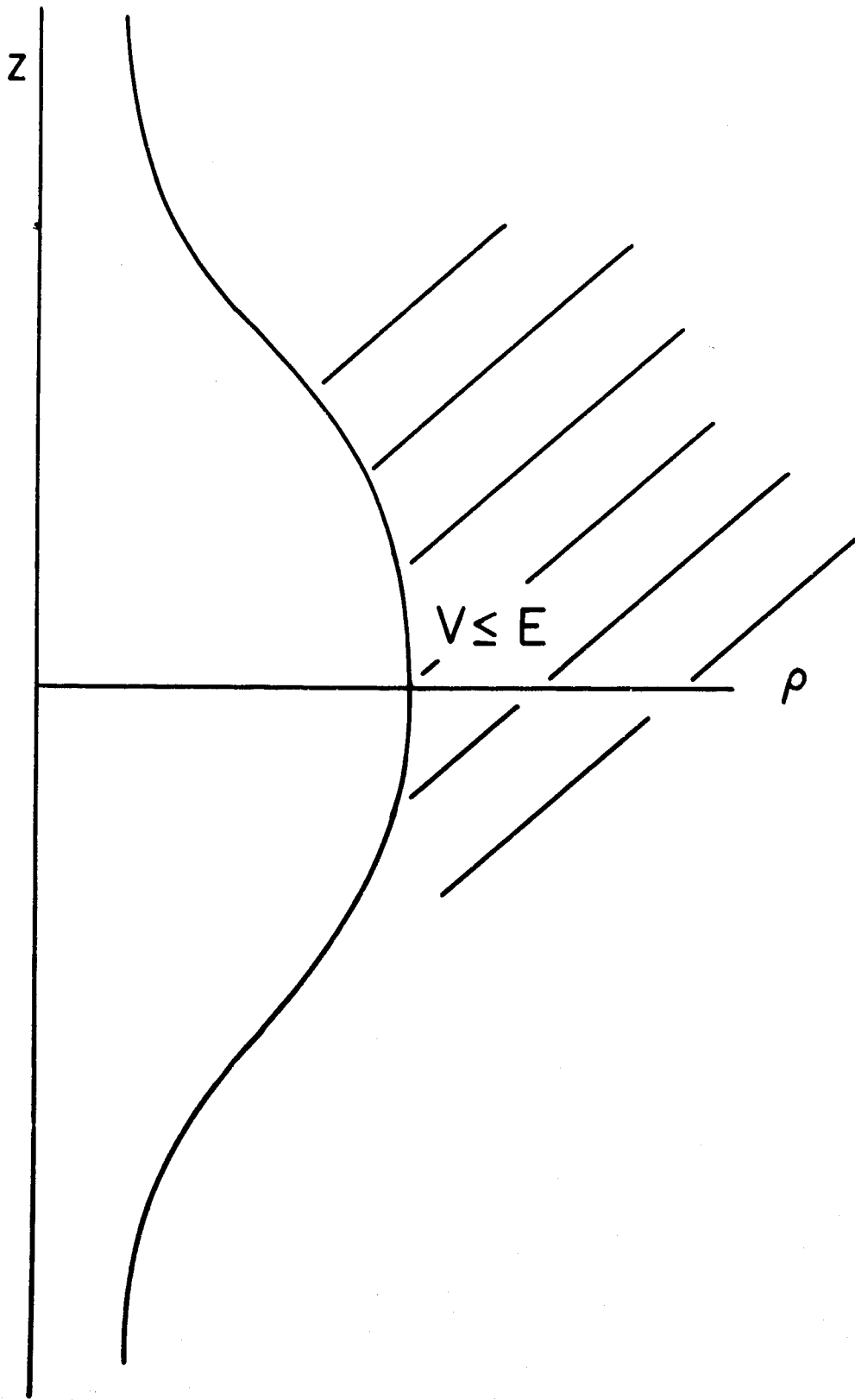

FIG. 4

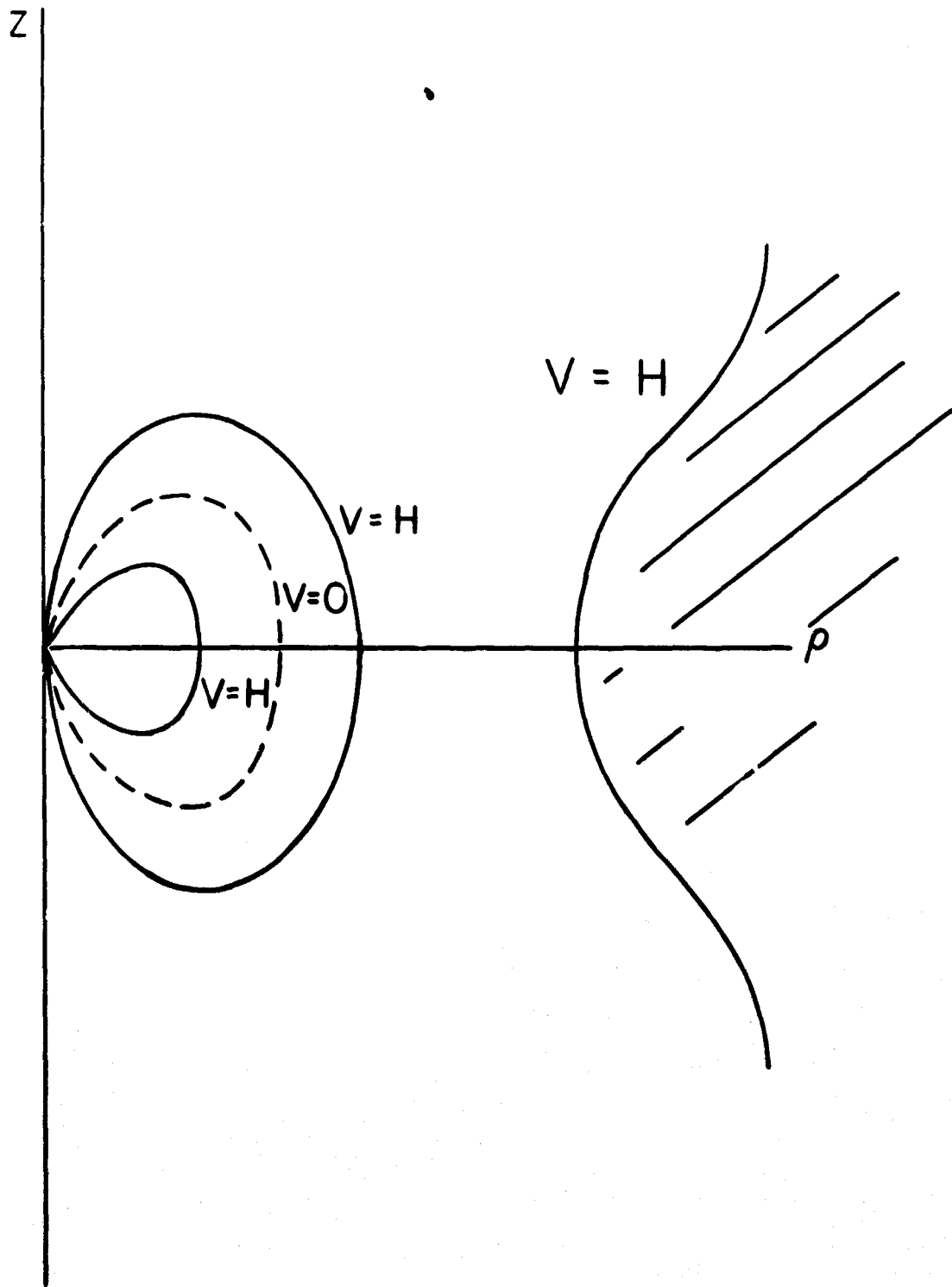

FIG 5

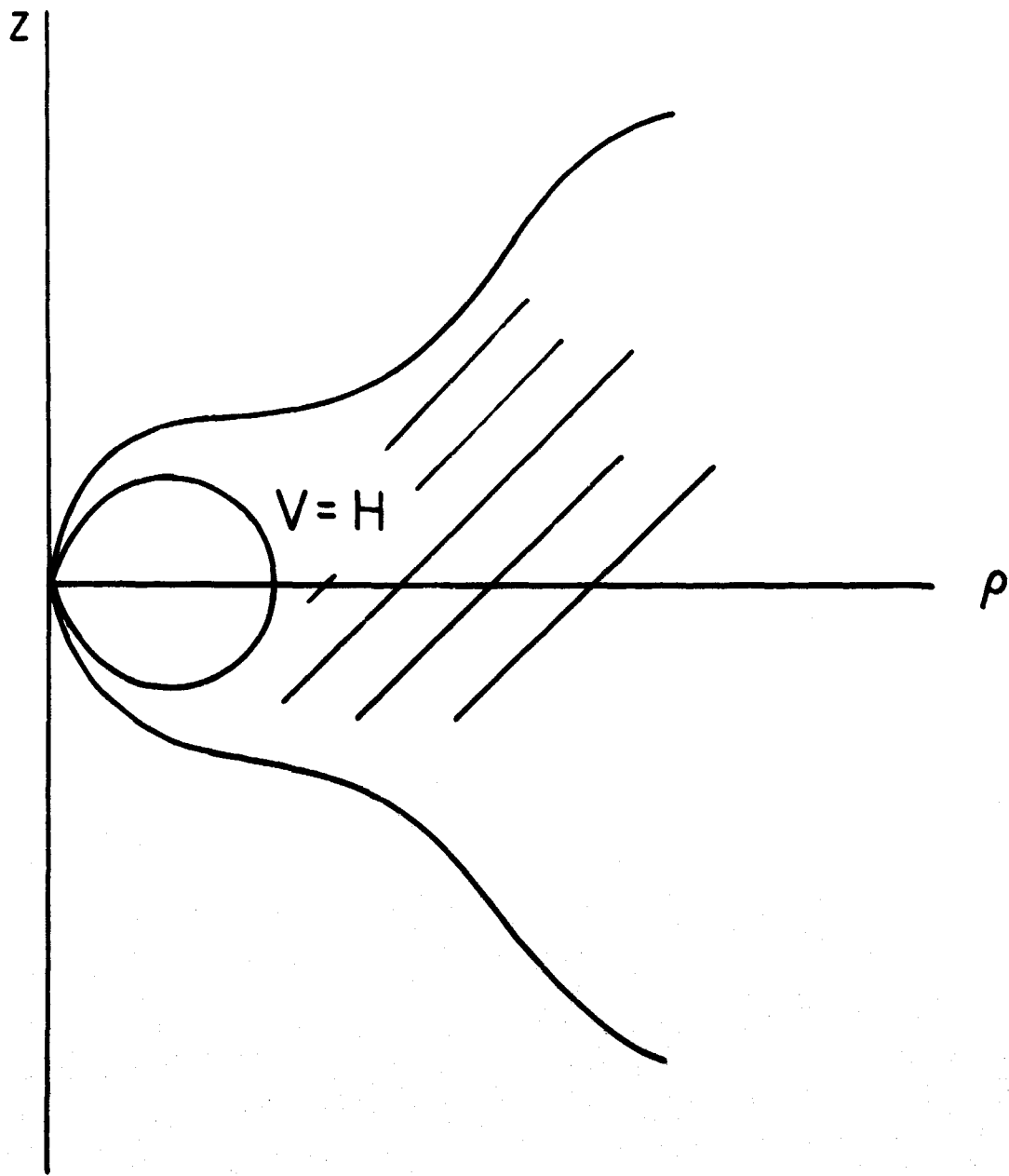

FIG. 6

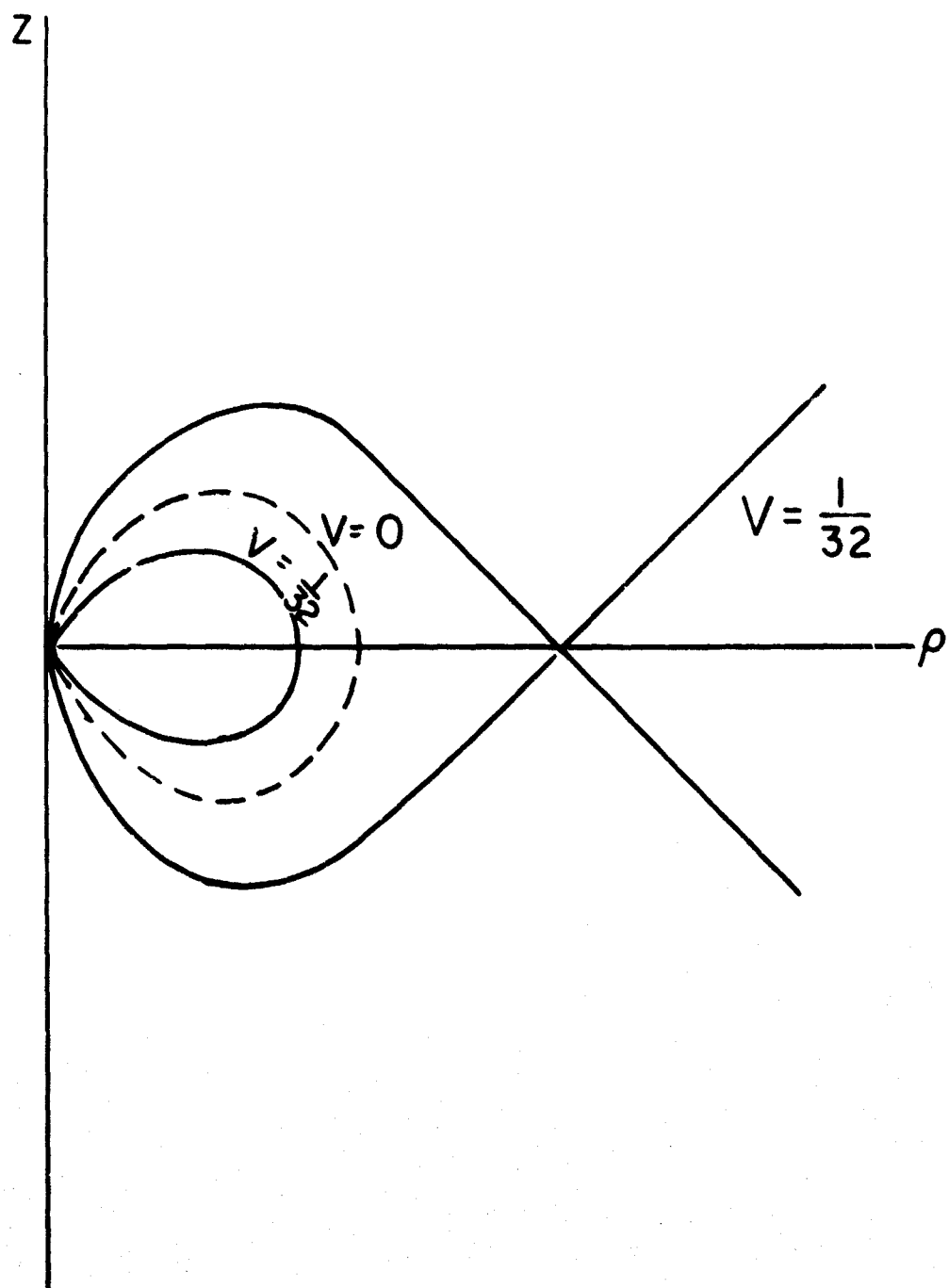

FIG. 7

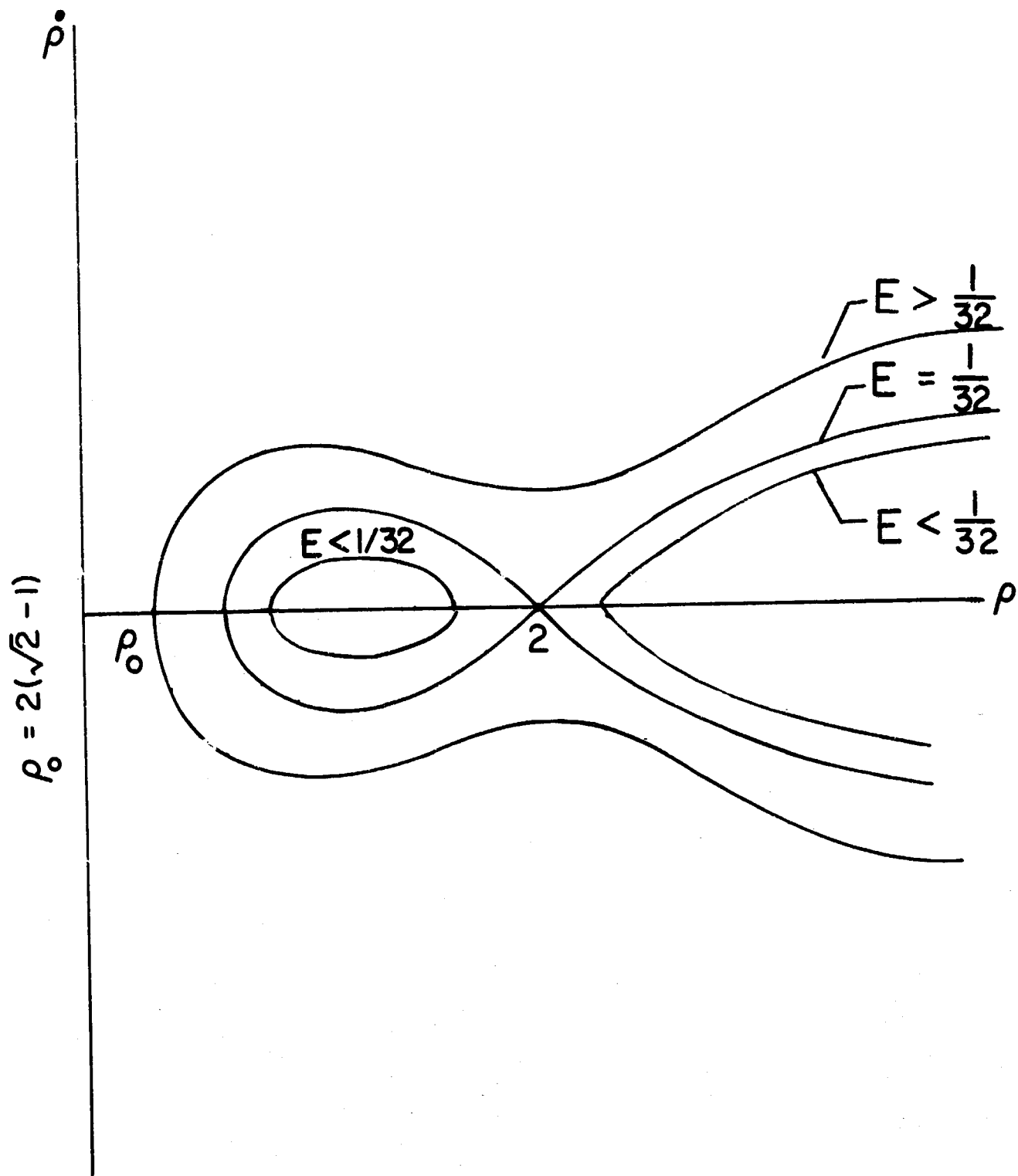

FIG. 8

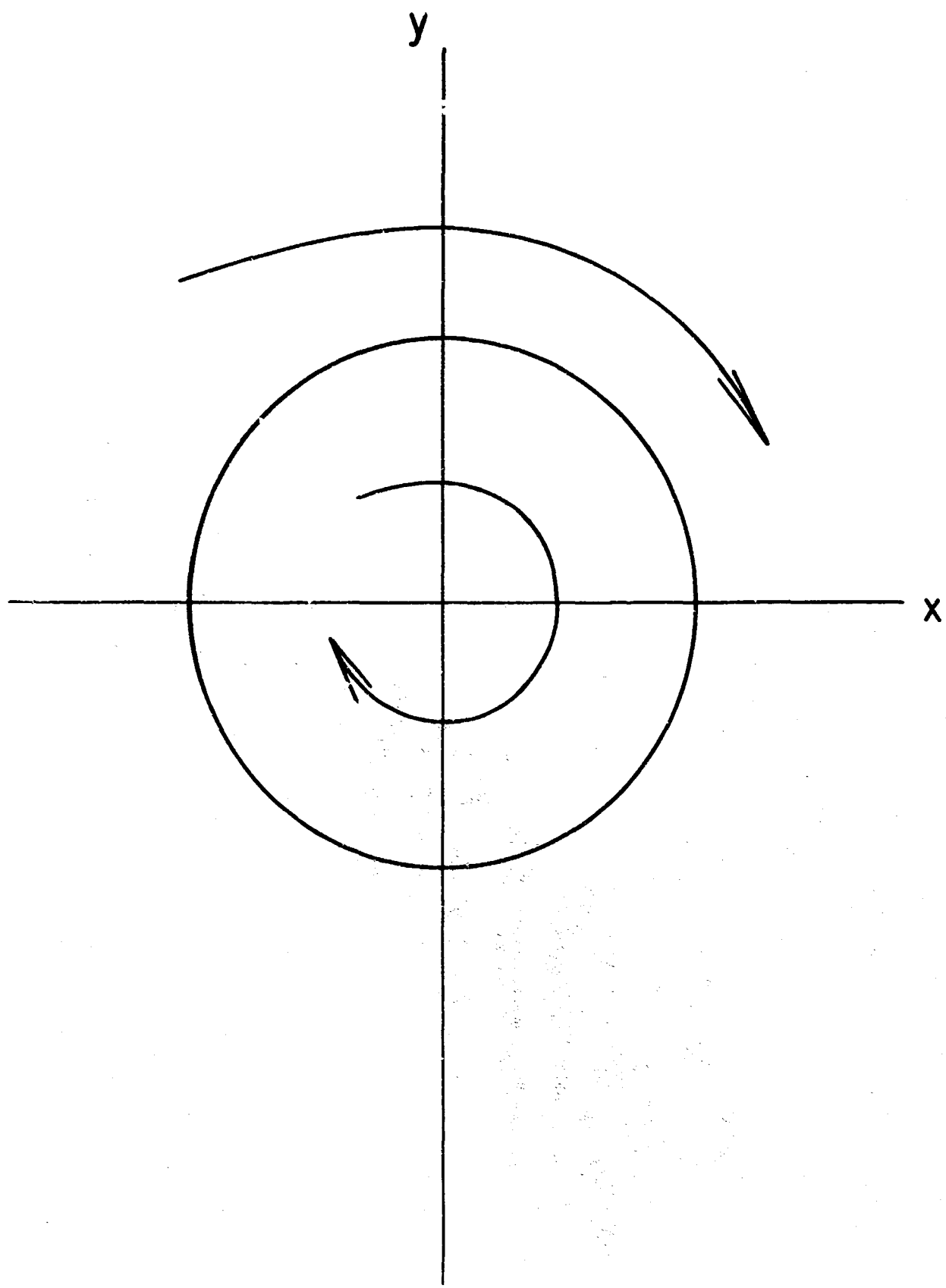

FIG. 9

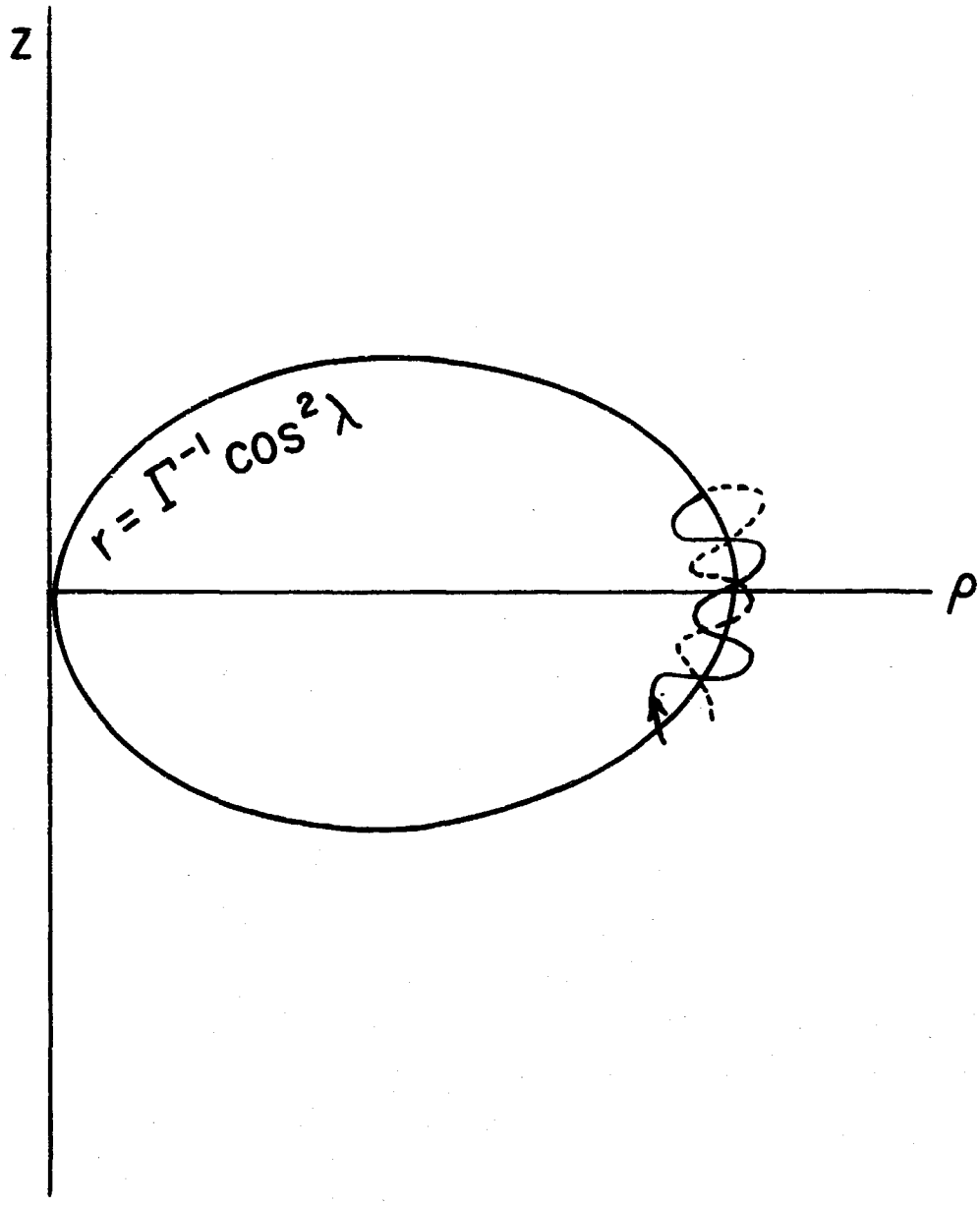

FIG 10

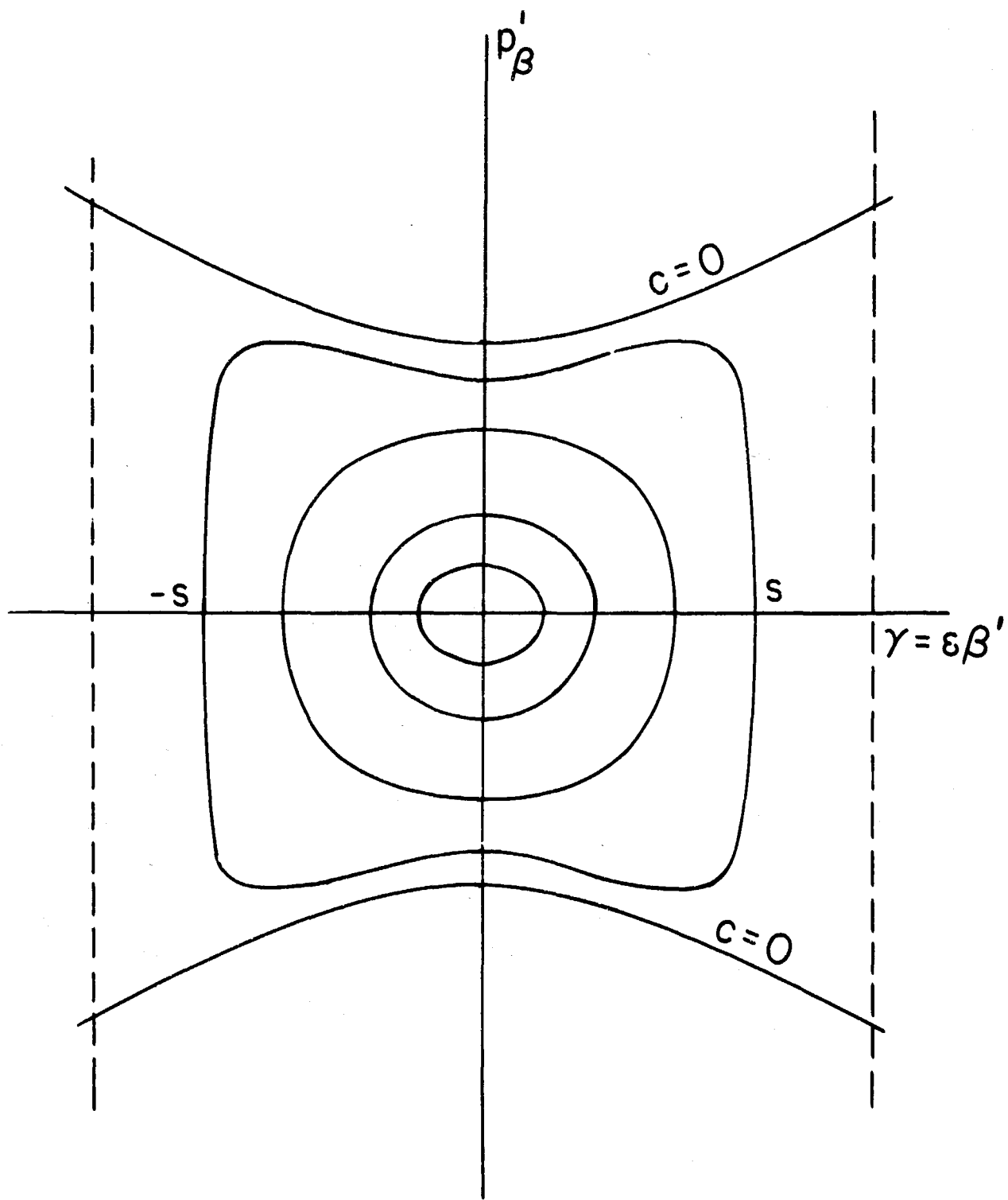

FIG. II

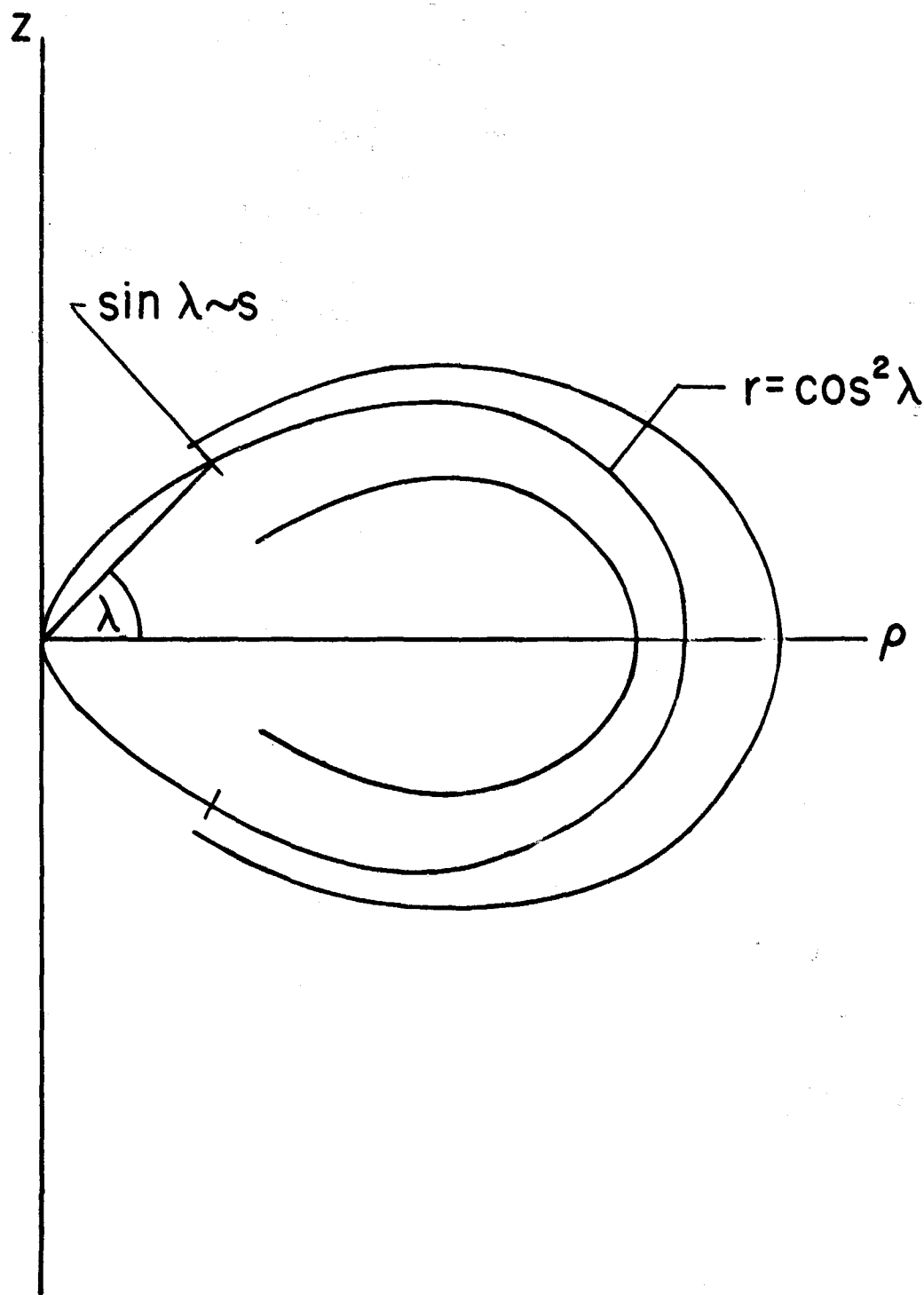

FIG. 12

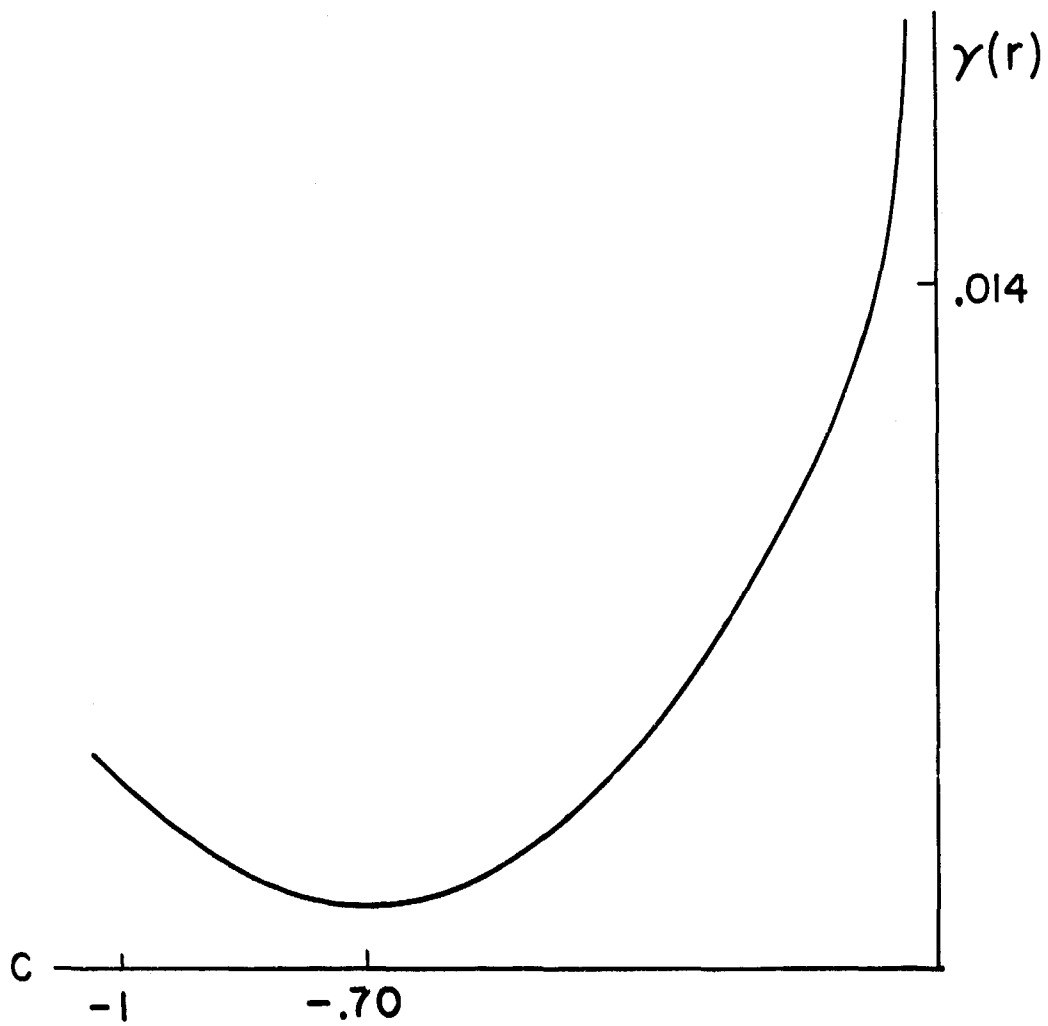

FIG. 13

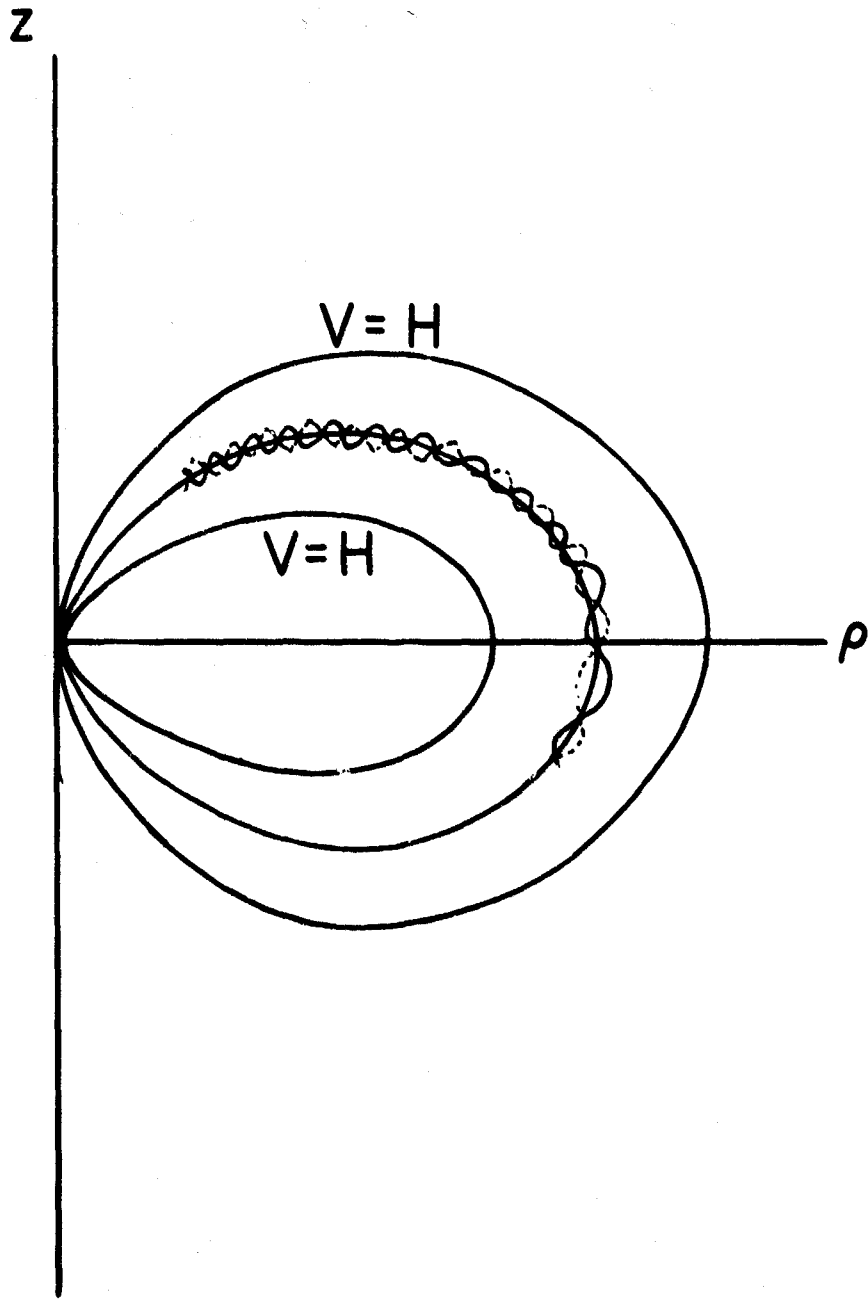

FIG 14

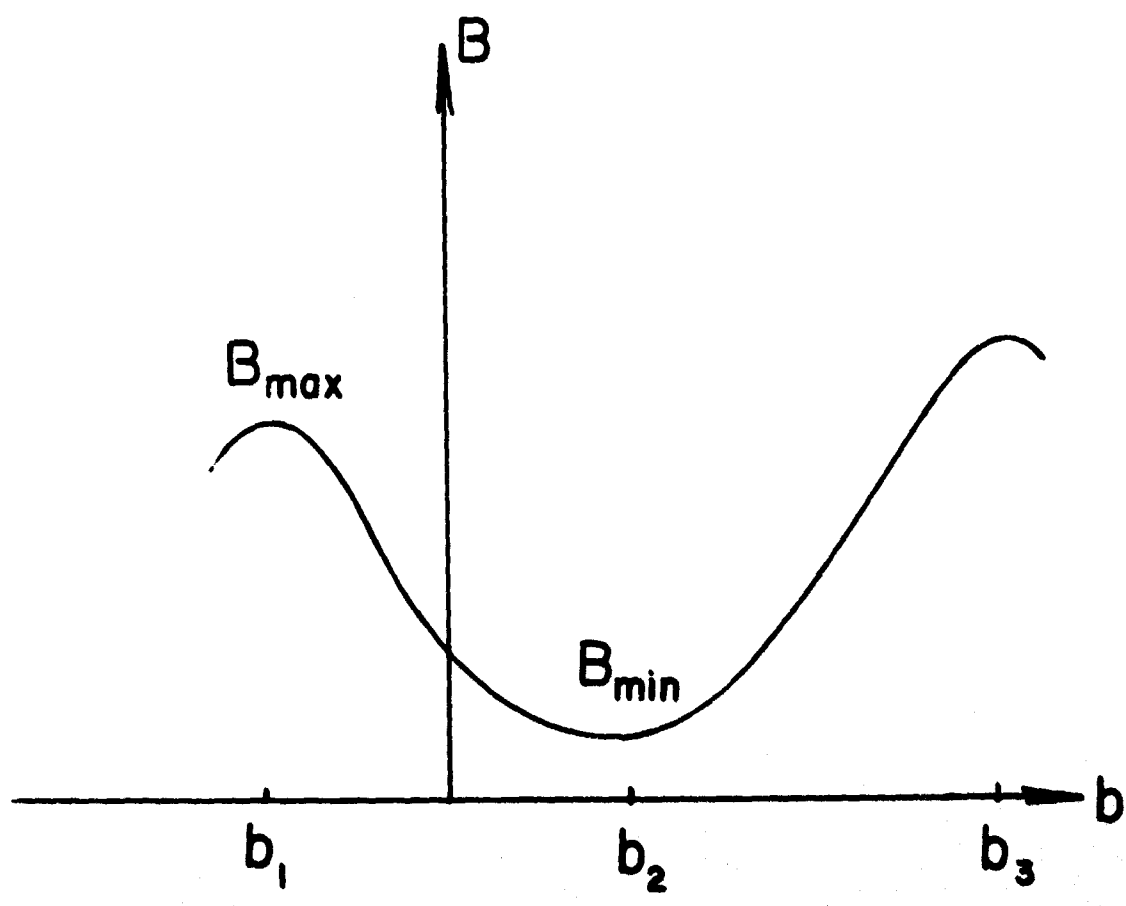

FIG. 13

DOCUMENT CONTROL DATA - R & D		
1. ORIGINATING ACTIVITY (Corporate author) Brown University Division of Applied Mathematics Providence, Rhode Island 02912		2a. REPORT SECURITY CLASSIFICATION UNCLASSIFIED 2b. GROUP
3. REPORT TITLE PARTICLE MOTIONS IN A MAGNETIC FIELD		
4. DESCRIPTIVE NOTES (Type of report and inclusive dates) Scientific Interim		
5. AUTHOR(S) (First name, middle initial, last name) Martin Braun		
6. REPORT DATE March 1969	7a. TOTAL NO. OF PAGES 84	7b. NO. OF REFS 14
8a. CONTRACT OR GRANT NO. AF-AFOSR 693-67	9a. ORIGINATOR'S REPORT NUMBER(S)	
b. PROJECT NO. 9749-01	9b. OTHER REPORT NO(S) (Any other numbers that may be assigned this report) AFOSR 69-1126TR	
c. 6144501F		
d. 681304		
10. DISTRIBUTION STATEMENT 1. This document has been approved for public release and sale; its distribution is unlimited.		
11. SUPPLEMENTARY NOTES TECH, OTHER	12. SPONSORING MILITARY ACTIVITY Air Force Office of Scientific Research (SRMA) 1400 Wilson Boulevard Arlington, Virginia 22209	
13. ABSTRACT This report is concerned with rigorously establishing the existence of quasi-periodic motions for a charged particle in a magnetic field. The following results are obtained: (i) The existence of quasi-periodic motions lying near the equatorial plane for a charged particle moving under the influence of the earth's magnetic field (considered here as a magnetic dipole). This proves the stability of the periodic "equatorial orbits" for small values of energy. (ii) The existence of quasi-periodic motions which need not lie near the equator, exhibiting thereby the trapping of particles as observed in the Van Allen radiation belt. Moreover, these motions may penetrate arbitrarily close to the dipole, a result which was somewhat unexpected. (iii) The existence of quasi-periodic motions in a rotationally symmetric magnetic "minor field".		

DD FORM 1473