

AD 686720

**RESEARCH
ANALYSIS
CORPORATION**

Cost Uncertainty Analysis



Reproduced by the
CLEARINGHOUSE
for Federal Scientific & Technical
Information Springfield Va. 22151

DISTRIBUTION STATEMENT
This document has been approved for public re-
lease and sale; its distribution is unlimited.

ECONOMICS AND COSTING DEPARTMENT
PAPER RAC-P-29
Published May 1967
Second Printing May 1968

DISTRIBUTION STATEMENT
This document has been approved for public re-
lease and sale; its distribution is unlimited.

Cost Uncertainty Analysis

by
Frank J. Husic



RESEARCH ANALYSIS CORPORATION

MCLEAN, VIRGINIA

FOREWORD

This paper was prepared for presentation at the Nineteenth National Meeting of the Joint Study Group on Military Resource Allocation Methodology, Washington, D.C., 9-12 May 1967.

CONTENTS

Foreword	iii
Abstract	2
Introduction	3
Cost Uncertainty in Decision Making	3
Value of Uncertainty Analysis	6
Description of Techniques	9
Derivation of Moments Technique--Monte Carlo Technique-- Symmetric-Approximation Technique	
Future Study	16
Comparison of Techniques--Sample Analysis for Large-Scale Cost Model--Development of "Best" Set(s) of Distributions	
Conclusion	18
References	19
Figures	
1. Distribution of Probabilities in Dice Throws	5
2. Inputs Matrix	7
3. Alternative Comparison--Case 1	7
4. Alternative Comparison--Case 2	8
5. Alternative Comparison--Case 3	8
6. Alternative Comparison--Case 4	9
7. Derivation of Moments Technique	10
8. Sample Set of Distributions	11
9. Format for Derivation of Moments Technique for Two-Equation Model	12
10. Example of Derivation of Moments Technique for Two-Equation Model	13
11. Monte Carlo Technique	15
12. Symmetric-Approximation Technique	17

Cost Uncertainty Analysis

ABSTRACT

An important aspect of cost research is the measurement of the uncertainty inherent in the projection of system cost. Approaches to this problem have in the past centered on intuition of the decision maker or on sensitivity analysis. Only recently have approaches utilizing such tools as statistical decision theory and probability theory been formulated. The study described here explores and evaluates three such techniques.

Each approach requires:

(a) Expression of input estimates as probability distributions reflecting uncertainty.

(b) Cost equations pertinent to the particular model.

Each approach generates:

(a) Frequency distributions for cost elements and aggregations.

(b) Statistical measures that illustrate the nature and magnitude of the system cost uncertainty.

The approaches evaluated are:

(a) Derivation of Moments Technique. This employs equations for deriving the moments and distributions for cost elements and aggregations.

(b) Monte Carlo Technique. This is a simulation routine to be used in conjunction with RAC's Individual System/Organization Cost model.

(c) Symmetric Approximation. This is a special case of the derivation of moments technique.

Finally the evaluation aims at two considerations:

(a) The value of such information on uncertainty to the Army decision maker and analyst.

(b) Comparison of the relative costs and advantages of each approach described above.

INTRODUCTION

The purpose of this paper is to describe ongoing research for improving and evaluating methodologies for quantifying uncertainty in cost analysis. This research was conducted under the sponsorship of the Director of Cost Analysis of the Office of the Comptroller of the Army. Approaches to the measurement of the uncertainty present in cost models have in the past centered at worst on the intuition of the decision maker and at best on sensitivity analysis. Only recently have approaches based on statistical-decision theory and probability theory been attempted. The purpose of the study is to explore and evaluate three such approaches. More specifically this research attempts to:

- (a) Determine the value of information on uncertainty to the Army decision maker and the analyst.
- (b) Compare relative costs and advantages of each approach studied.
- (c) Develop an operational technique for use by RAC and Army cost analysts.

The three approaches under evaluation are:

- (a) Derivation of Moments Technique. This employs equations for deriving moments of cost elements and aggregations and distribution parameters of aggregations.
- (b) Monte Carlo Technique. This is a simulation routine to be used in conjunction with RAC's Individual System/Organization Cost (ISOC) Model.^{1,2}
- (c) Symmetric Approximation. This is a special case of the derivation of moments technique.

COST UNCERTAINTY IN DECISION MAKING

The process of decision making and thus the fundamental task of the decision maker is to choose among alternative courses of action. Often such choice will involve a cost-benefit analysis of either a formal or informal nature. With a formal analysis as our context, let us examine what has been given the decision maker as costs.

The precise calculation of costs is not a difficult task. The availability of computers and cost models can reduce this to routine. The calculation itself is precise and can be done rapidly in minute detail.

The inputs to these precise calculations are, however, not precise; in fact they are often quite the opposite. The errors present in each input are passed on to various aggregations until one arrives at a total cost that somehow involves each individual error. Thus, cost inputs are combined in a computer model with a multiplicity of equations and hundreds of other inputs to

form a single estimate of total costs. This single estimate is presented to the decision maker with the implication that although it may not be perfect, it is certainly the best available estimate, without any statement as to likelihood of occurrence or range of other possible values.

But in the generation of this aggregate number, hundreds of imprecise numbers may have been used. This fact is not emphasized to the decision maker, nor does he have a basis to judge the precision of the numbers. Cost models as currently conceived and used, then, uniformly withhold from the decision maker some information that might be vital to his decision. We have neglected to tell him all we know about the subject of the accuracy of our estimates.

As an example, let us suppose that one of the cost elements is a missile airframe. The missile is not yet designed or built, so no production-cost data are available. A cost estimating relation (CER) could be used, for example, to estimate that the airframe cost for a new missile would be about \$32,000. The design group, however, warns that some added sophistication might make the CER predict on the low side, but that improvements in some manufacturing techniques promise lower costs. Some quick calculations show estimates as low as \$26,000 and as high as \$45,000. Each of these calculations is based on a set of assumptions concerning labor and overhead rates, material costs in the future, and design details not yet firm and subject to some uncertainty. Each factor is considered, and the analyst enters his final estimate as \$36,000.

For each of a multitude of other important inputs, similar decisions are made, and a single aggregate cost is obtained as the output of the cost model. This is somewhat analogous to describing the outcome of a dice throw by the most likely outcome, 7. It says nothing about the almost as likely 6's and 8's or of the extremes of 2 and 12 as shown by Fig. 1. Expanding this analogy to eight dice each with 100 sides, we begin to approach the variations possible in cost estimates for decision making.

Obviously we are not telling this hypothetical decision maker all we know or all he needs to know to make a rational decision when we report a single-cost estimate.

The dangers of the single-cost estimate have been recognized for years, and several strategies have been developed for augmenting the analysis or circumventing the difficulty. One is isolation of the differences between alternatives. Cost elements common to alternatives are estimated in a similar or identical manner so that only the uncertainties of the unique features of alternatives affect relative cost. Another is the use of sensitivity analysis. Sensitivity analysis computes the impact of errors in estimates and assumptions, identifying error sources important to the choice of alternatives. It can produce proof of insensitivity, or it can provide evidence that, within a relevant range of values, choice is or is not affected by estimation error.

Returning to the dice analogy of Fig. 1, this is like saying 7 is most likely, but the number could go as low as 2 or as high as 12. If the possibility of 2 or 12 affects choice, supplying that information tells the decision maker something he needs to make a choice. However, the fact that 2 or 12 are the least likely outcomes has not been given. In a similar manner, sensitivity analysis, using judgments about the relevant range, produces an array of numbers that include the analysts' beliefs concerning the limits of the variables

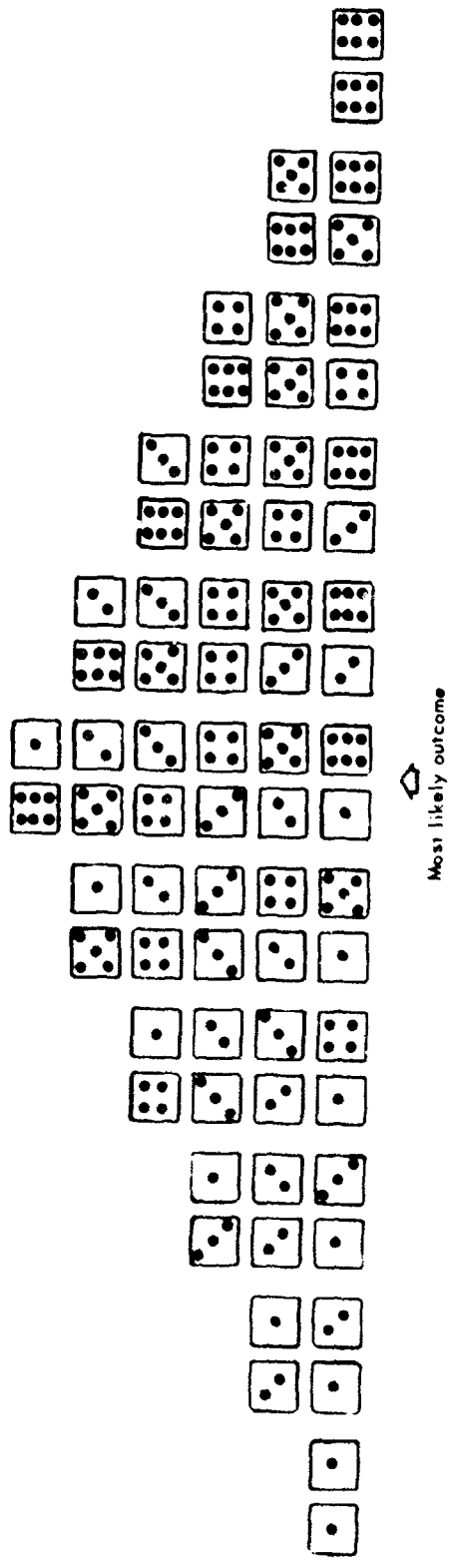

Fig. 1—Distribution of Probabilities in Dice Throws

but excludes any knowledge of relative probability. No probability statements are furnished, and the decision maker could be led to believe that all numbers in the array are equally likely.

The choice of a relevant range of values for sensitivity analysis is both difficult and critical to its usefulness. It also reveals a dilemma inherent in the application of sensitivity analysis. If the analyst has evidence that the value of one of the inputs is constrained within some upper and lower limits, then this same evidence may provide information on the relative likelihood of particular values. If he has only an intuitive belief about the range, this too may be accomplished by equally valid suppositions concerning probabilities of the values within the range.

In the previous example of the missile cost, if the reasoning that fixed the relevant range of costs at \$26,000 to \$45,000 could yield information on the probability of occurrence, then we could supply the missing information in a form useful to the decision. A possible statement might be that there is a 99 percent probability that the cost is less than \$44,000. Combined with the other elements of the cost model with similar statements, we might say that although the maximum cost produced by the sensitivity analysis is, say, \$800 million, there is a 99 percent probability that the cost will not exceed \$720 million. In the sensitivity analysis, if the \$800 million number exceeded slightly the cost of another alternative under similar sensitivity assumptions, the decision maker may have been furnished an unlikely cost set for consideration along with all other sensitivity sets, and this set may uniquely favor a different alternative. Knowing just a few simple probability statements, then, can preclude earnest consideration of cost estimates whose likelihood is very remote.

In short, although sensitivity analysis is a powerful tool for portraying the results of estimating error, it leads to pondering highly unlikely situations. The same reasoning that leads to a determination of relevant range for sensitivity analysis has the potential of providing key information in decision making. The importance of utilizing this information is, we believe, as great as that of providing cost analyses at all.

VALUE OF UNCERTAINTY ANALYSIS

Having considered the shortcomings of present approaches, let us consider what benefits can be expected for analyst and decision maker from use of probability information.

Principal value for the analyst seems to lie in the isolation of major sources of uncertainty in the model. We can construct for conceptual purposes the matrix shown in Fig. 2 illustrating the nature of inputs.

Without probability-distribution techniques the analyst was unable in the past to ascertain into which of the cells of the matrix an input item fell. Now applying probability techniques one can determine this kind of information and feed it back to the analyst. Particularly important are the isolation of X_{11} -type inputs, i.e., those possessing highest uncertainty and contribution to total cost. Presumably cost analysts would want to work on developing more accurate estimates of these items than, say, X_{n1} items where total contribution is lowest

despite high uncertainty. At any rate this information can tell the analyst more clearly than ever before to which inputs the total cost is most sensitive.

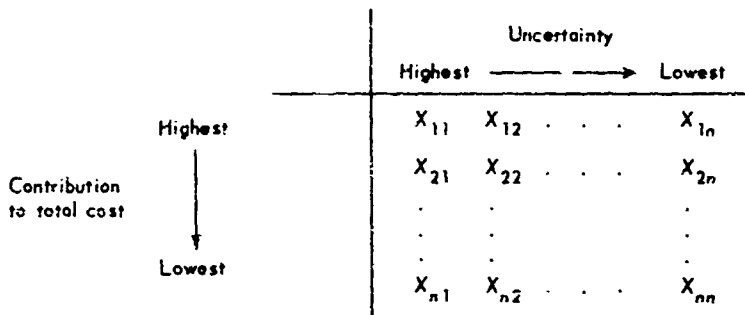

Fig. 2—Inputs Matrix

Potential value to the decision maker can best be described by some illustrations. In each illustration the frequency distributions for two alternatives are shown. The horizontal axis in each case represents the cost of the alternative and is increasing to the right. The vertical axis represents the likelihood of occurrence at each cost level. Each of these is a hypothetical case in which equal effectiveness or other benefits are assumed. The decision maker's problem is that of choosing the least-cost alternative. If only single-point cost estimates were provided, the decision maker would of course feel constrained to select the lower cost in each case. However, Fig. 3 demonstrates how information provided by probability estimation could modify his outlook.

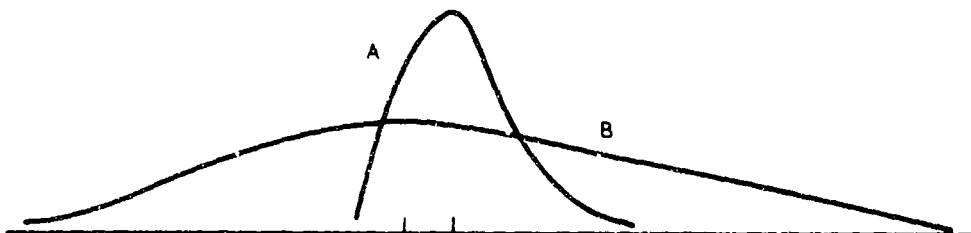

Fig. 3—Alternative Comparison—Case 1

Most likely value A > most likely value B
variance A < variance B

The peak of each curve is at the most likely, or modal, value, and that is, in our hypothetical cases, the only cost total that would be furnished a decision maker in the absence of uncertainty analysis. In this example, B is expected to be less expensive, but it has a larger variance so that higher costs are more likely than with A. Faced with this dilemma, the decision maker may decide to avoid extreme costs by choosing A or to gamble on the expected lower costs of B. We cannot prescribe for him, but by providing the probability distributions, we have made known to him a pitfall in selecting the "less expensive" alternative.

Figure 4 illustrates a clear-cut case. The largest possible cost of one alternative is less than the smallest possible cost of the other. Decision

makers furnished with this information are not likely to choose differently than if only point estimates were given. They are, however, furnished an assurance that no combination of likely errors of estimation would result in a reversal of relative costs. It should be noted that this cannot be done with sensitivity analysis. There might exist a combination of extreme values, each within a relevant range, in which the cost ranking is reversed, but sensitivity analysis would furnish no clue that it is a condition with negligible probability of occurrence.

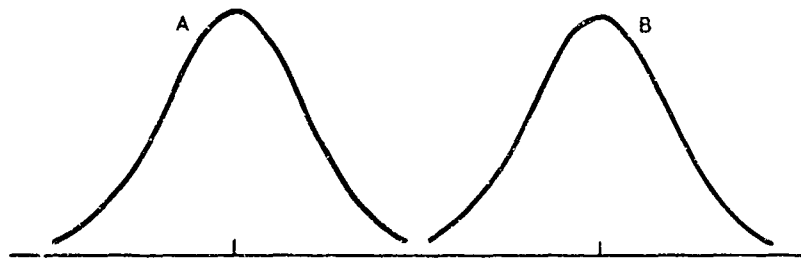

Fig. 4—Alternative Comparison—Case 2

Most likely value A < most likely value B
No overlap of distributions

In Fig. 5 a single-point estimate would furnish no basis for choice. With mean values essentially the same the decision maker must look elsewhere for differences. If the probability distributions are furnished, however, it is apparent that the costs cannot be regarded as equal. If they appear as shown here, we presume that A would be chosen, since it can be better accommodated in the budgeting and financial management system. The possibility of much lower than mean costs may have some value too, and as a result it becomes impossible to speculate on choice outside specific cases. The important thing is that information helpful in the decision process has been furnished that would not otherwise be available.

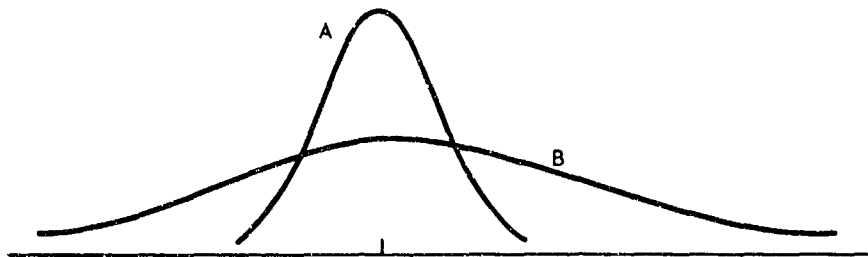

Fig. 5—Alternative Comparison—Case 3

Most likely value A = most likely value B
Variance A < variance B

The costs associated with two alternatives may or may not be significantly different. Fig. 6 illustrates two cost totals, each with the same variance. If variance is low, the situation is as in the second example; costs are

different and offer a basis for choice as conclusive as the magnitude of the difference might indicate. Larger variances diminish the importance of the most likely value cost difference. At some combination of "closeness" and high variance the cost difference may not be of significance in the selection of an alternative. In any case, quantification of the probabilities of the differences is a useful contribution to the decision maker's understanding.

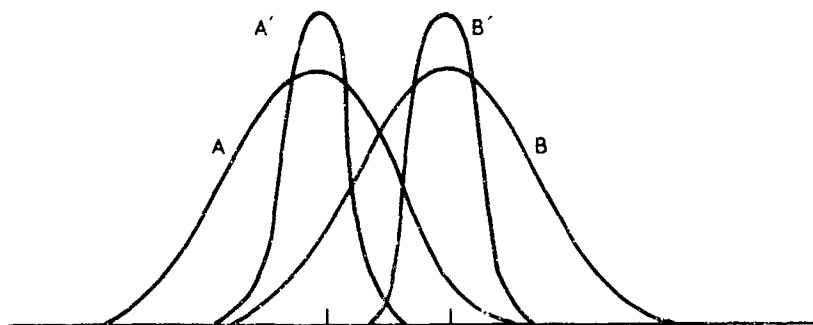

Fig. 6—Alternative Comparison—Case 4

Most likely value A < most likely value B
 Variance A' = variance B'; most likely value A' < most likely value B'
 Variance A' = variance B'; variance A' < variance A
 Variance B' < variance B

These four examples, it should be noted, differ only quantitatively. They are offered in these forms to illustrate the range of possibilities in which useful information may come from a knowledge of the probability distributions of total cost.

DESCRIPTION OF TECHNIQUES

Having looked at shortcomings of present approaches and possible benefits of providing probability information, let us now turn to a discussion of three techniques for providing such information.

Each technique utilizes a different method of producing the same kinds of information. Each assumes that cost distributions are approximated by beta distributions. This does not seem illogical. Beta distributions are unimodal, finite, and continuous. All of these seem to be characteristics of most cost items dealt with in Army models. Each technique further assumes independence of cost inputs. This could prove limiting in certain situations. A number of approaches to handling dependency can be applied. Among these are incorporation in the model of the functional relation between the variables, statement of the dependent variable in terms of auxiliary variables, and use of joint probability distributions. The problem of independence is not felt to be prohibitive although the systematic handling of input dependency is still an area for research. Finally the beta distribution can, as opposed to, for example, normal distributions, describe various conditions of skewness and peakedness, which is desirable in the context of cost analysis. In each section there is a discussion of (a) the general logic of each technique, (b) required inputs, and (c) characteristic outputs.

Finally for one of these techniques, the derivation of moments, an extremely simple model is presented both to illustrate the workings of this model and to give a better understanding of what this kind of technique can do.

Derivation of Moments Technique

The principles underlying this technique are (a) a distribution may be described by its first four statistical moments, and (b) these moments may be combined according to certain equations to give the moments and the distributions of various cost aggregations.

Figure 7 is a generalized flow diagram of the derivation of moments technique. We note that this routine has three major sections or phases. Phase I accepts user input describing cost items and converts this for each cost item to the first four statistical moments of the beta distribution determined by the input. These sets of moments become input to Phase II, along with a description of the relations between cost items in a particular model. Phase II combines moments according to these predetermined relations. The outputs of Phase II then are the first four moments of each combination or aggregation. Finally Phase III computes the parameters and produces plots of the beta distributions determined by the aggregate moments.

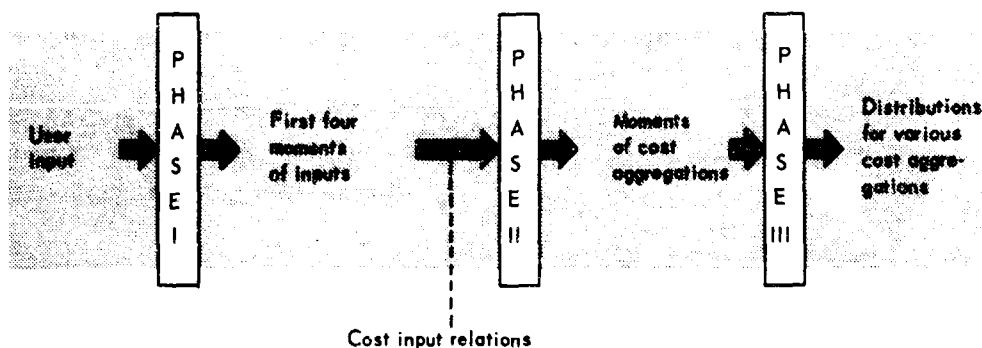

Fig. 7—Derivation of Moments Technique

This technique is an adaptation of an approach first formulated by Sobel of MITRE.³ However, several changes that were felt to be significant were made in the original program.

Perhaps the most important adaptation was the complete revision of Phase I of the program. The original routine required a user to input the following four parameters: X_P , most probable value; X_H , high value; X_L , low value; and CR , 80 percent central range (defined to be that range of the variable which contains 80 percent of the probability). The estimation of this latter parameter was felt to be extremely difficult and at best subject to great error. Efforts toward modifying this requirement led to the following new approach. It is in principle similar to that described by Dienemann.⁴ Instead of allowing the analyst to specify any beta distribution, a fixed set of distributions, each of which could be described qualitatively in terms of variance and skewness, was developed. Figure 8 illustrates the set of nine distributions with which tests are being run. In this scheme variances are listed as high,

medium, and low, and distributions are skewed right, symmetric, and skewed left. Thus the user specifies the type of distribution selected from the given set and any two of the following three parameters: most probable value, high value, and low value. Since the parameters of the distributions have been fixed, specification of three of the above parameters would overspecify the distribution and could produce distortions in the representations of the curve. Experience with analysts at RAC indicates that the analyst seems better able to pick a particular distribution from a fixed set than to estimate a number like the 80 percent central range. In addition the fixed-set approach allows for testing sensitivity of results to type of distribution selected. Thus the analyst may wish to see what happens to his cost figures if he assumes distributions are skewed right as opposed to symmetric. This fixed-set approach, then, is one of the major revisions to the original approach set forth by Sobel.

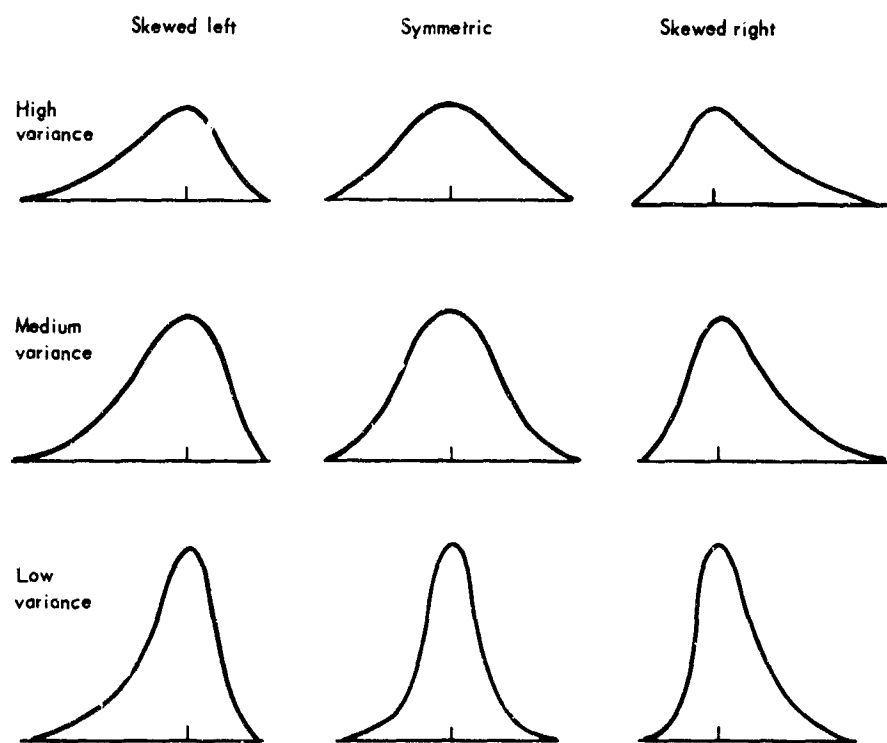

Fig. 8—Sample Set of Distributions

Several additions have been made to the original formulation. Previously only the parameters of the beta distribution were printed out by Phase III of the program. These consisted of the alpha and beta parameters along with the limits of a selected probability area such as upper and lower 10 percent tails. However, a routine has been added to plot the frequency distribution of different cost aggregations. This provides a graphic display of the possible cost spread along with the likelihood of different cost levels. This type of display is particularly effective in the comparison of alternatives. Finally, several

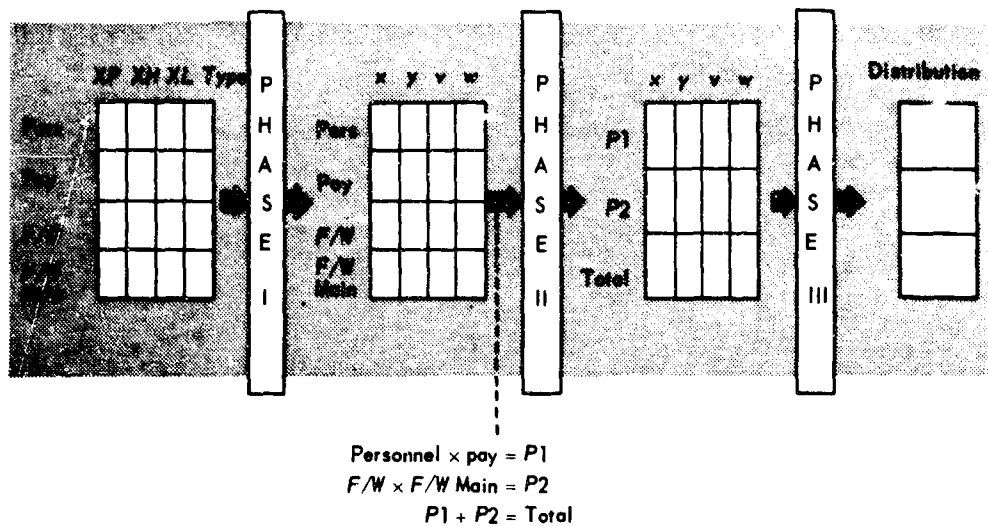

Fig. 9—Format for Derivation of Moments Technique for Two-Equation Model

additions of an operational nature, such as the automatic linking of phases of the program, have been made.

It might be helpful as a means of further illustrating this technique to trace its operation in the context of an extremely simple example. Figure 9 illustrates the flow diagram for a cost model consisting of the following two equations:

- (a) PERSONNEL (expressed in number of men) \times PAY (expressed in dollars per man)
- (b) FIXED-WING AIRCRAFT (expressed in number of planes) \times FIXED-WING MAINTENANCE (expressed in dollars per plane)

As inputs to Phase I the user specifies the most probable, high, and low values in addition to type of distribution. Phase I then outputs the first four moments of the beta distribution determined by each input set. Thus this model will output four sets of moments.

These four sets of moments now become input to Phase II. Along with these go the following three equations that make up our model:

$$P1 = \text{Personnel} \times \text{pay}$$

$$P2 = F/W \times F/W \text{ maintenance}$$

$$\text{Total cost} = P1 + P2$$

Phase II then outputs three sets of four moments. The first set represents the product of personnel and pay; the second, the product of fixed-wing craft and fixed-wing maintenance; and the third, the sum of these two products. These three sets now enter Phase III. The results of this phase will be the distributions determined by the three sets. They illustrate the cost spread implied in this model along with the relative frequency of each cost level. In addition, various parameters such as mean, variance, limits of probability areas, etc., can be readily obtained.

To further clarify operations of this technique, Fig. 10 illustrates the flow for the same two-equation model with sample Phase I input and Phase

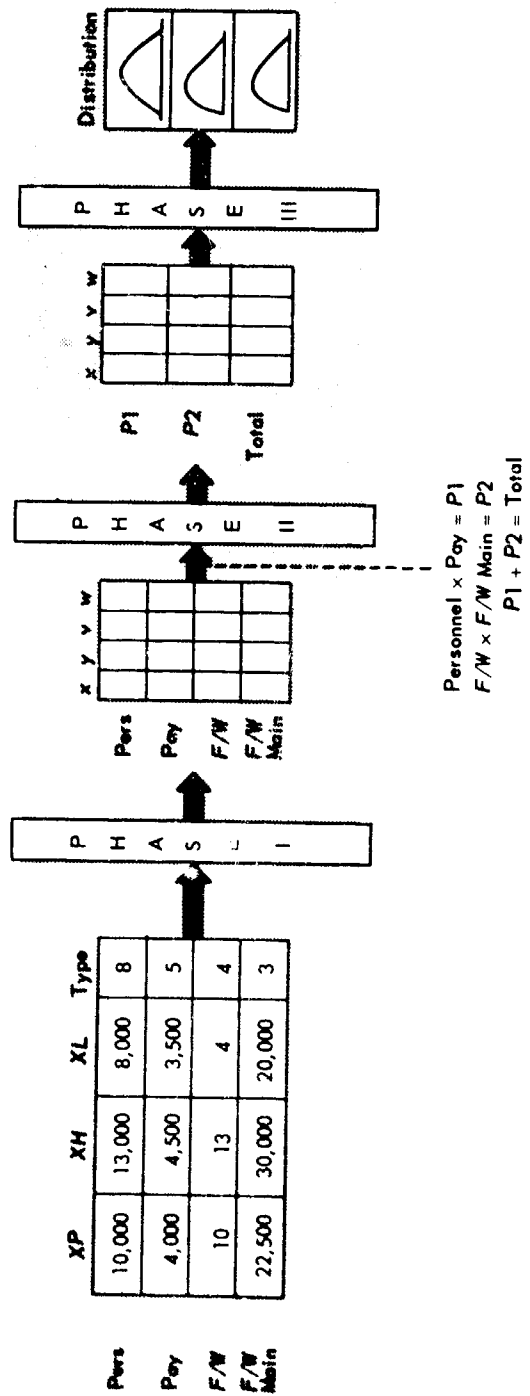

Fig. 10—Example of Derivation of Moments Technique for Two-Equation Model

III output. Thus for personnel, $XP = 10,000$ men, $XH = 13,000$ men, $XL = 8,000$ men, and type of distribution is 8. The selection of type 8 distribution from our list of nine implies a distribution of low variance with symmetry. Apparently the analyst here feels that a level of 10,000 men is fairly certain (indicated by picking low variance) and whatever deviation did occur would be likely to occur in either direction (indicated by picking symmetric distribution).

Outputs for Phases I and II are not shown since their addition would add no real understanding. Also only the frequency curves were shown as Phase III output because of space limitations. This simple example then illustrates the operation of the derivation of moments technique.

Monte Carlo Technique

Figure 11 is a general flow diagram of the Monte Carlo technique. This technique is quite similar to one formulated by Dienemann of the RAND Corporation.⁴ The principle underlying this technique is that if many iterations of the same cost model can be computed, while changing the value of the model's inputs in accordance with the given distributions on each iteration, the relative frequency of various cost levels can be computed, plotted, and statistically analyzed. The speed of the computer enables us to do this. Thus in this technique we construct, compute, and analyze a large number of iterations of the same cost model. These three functions provide a useful framework for examining the flow chart of Fig. 11.

The Monte Carlo subroutine functions as the constructor of the inputs to the iterations. It does this by selecting sets of values for the cost inputs. The subroutine accepts from the user the most probable, high, and low values along with a type of distribution for each cost input. These are the same parameters required by the derivation of moments technique. Based on the type of distribution and using a random number generator, the subroutine selects a value for each cost input. This set of values will be used for this particular iteration only. These values are next combined in the ISOC subroutine.

The ISOC subroutine is an adaptation of the ISOC computerized cost model formulated by RAC.^{5,2} It will accept (a) a different set of values selected by the Monte Carlo subroutine for each iteration and (b) the relations between the cost inputs. Since these relations hold for each iteration, they need only be input during the first iteration. With these inputs and relations the ISOC model will compute cost aggregations including total cost and store the results of the iterations for selected aggregations. Having stored this information the model will ask whether a sufficient number of iterations have been run. A number of methods for choosing this can be applied. If more iterations are required, control is sent back to the Monte Carlo subroutine for the generation of another set of values. If the required iterations have been executed, control passes to the final phase of the technique, the analysis subroutine.

The analysis subroutine (a) prepares a frequency distribution for each selected aggregation and (b) computes such statistical measures as mean and variance for the aggregations. The output of this subroutine thus closely resembles that of Phase III of the derivation of moments technique. In this approach, however, the distributions are not plotted from the parameters of a beta distribution but from the frequency of occurrence of various cost levels.

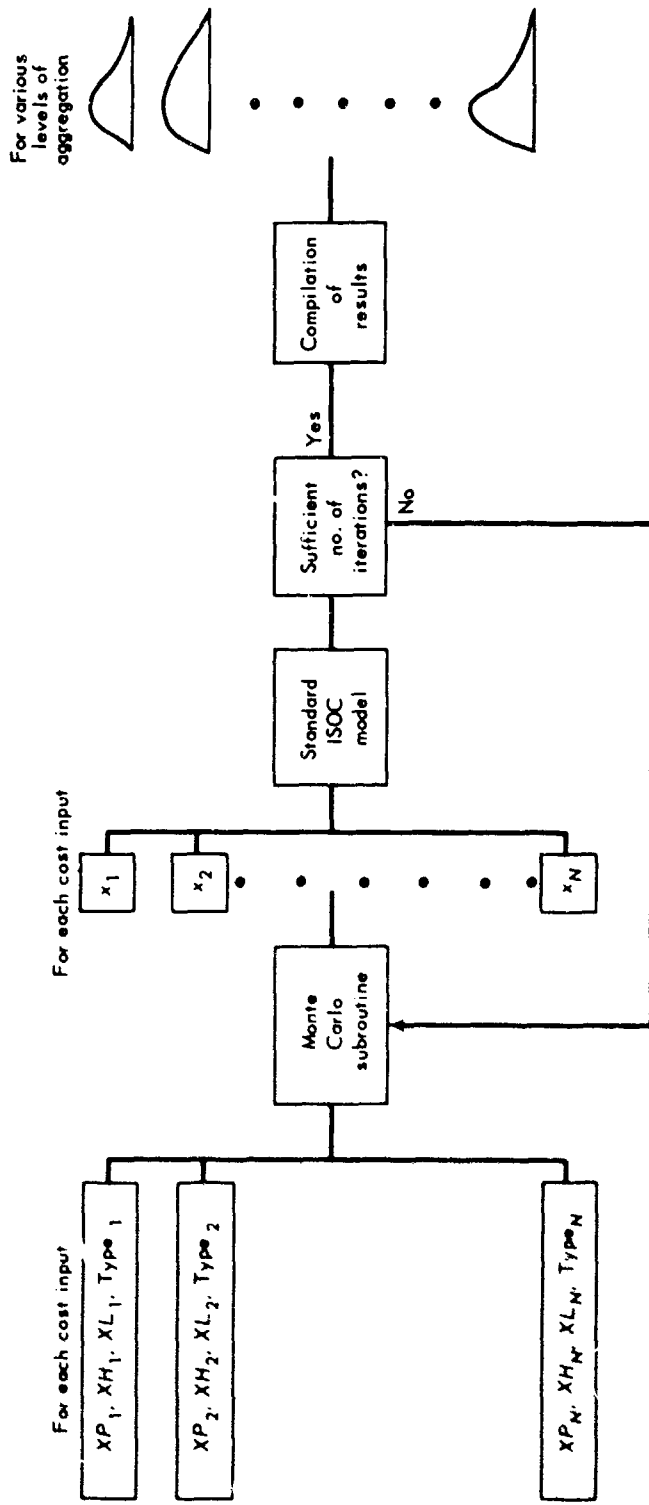

Fig. 11—Monte Carlo Technique

Symmetric-Approximation Technique

Figure 12 illustrates the symmetric-approximation technique. This method differs from the derivation of moments technique only in the calculation of cost-input moments. Since the remaining two phases are identical, we need only focus attention on Phase I of this technique. The heart of the technique lies in the four equations shown in Fig. 12. These are equations for approximating the moments of beta distributions. Note that the third and fourth moments are zero. This implies (a) the distribution is symmetric, and (b) the distribution has the same flatness as a normal curve. These equations were first formulated in the development of program evaluation and review techniques (PERT) when the time needed to complete a project was assumed to be beta-distributed. These equations do not require the user to input the type of distribution he feels characterizes a cost input. Thus the user inputs most probable, high, and low values only, and Phase I computes the first and second moments. These are then input along with cost input relations to Phase II—identical to Phase II of the derivation of moments technique. Once again moments of aggregations are outputs of Phase II and feed into a Phase III identical to that of the derivation of moments technique.

Several reasons prompted selection of the technique for evaluation. Such equations have been used to develop cost ranges for cost-effectiveness studies. The author also wished to find whether results were significantly affected by attempts to measure skewness and peakedness. Finally the author was interested in measuring at least qualitatively the validity or accuracy of these approximating equations.

FUTURE STUDY

As was mentioned at the start, this paper describes an ongoing study at RAC. This means that what has been presented here is not a final product. Rather, it represents a progress report designed to develop interest in these kinds of techniques and possibly to provide a basis for dialogue with others working in this field of uncertainty quantification. Also it extended the opportunity for the author to pull together the pieces of the study, to evaluate efforts to date, and to give direction to future research. The following are several areas that will be investigated in the future.

Comparison of Techniques

Consistent with objectives, first effort will go to a comparison of relative costs and advantages of each technique. Thus far comparison has been limited since one of the models is not yet completely operational. However, some conclusions that seem significant have been reached:

1. The Monte Carlo approach seems more flexible since one could allow distributions other than beta as inputs with minimal programming changes.
2. Monte Carlo also allows use of existing cost models in its total scheme whereas the other two currently accept the format of the derivation of moments technique only.

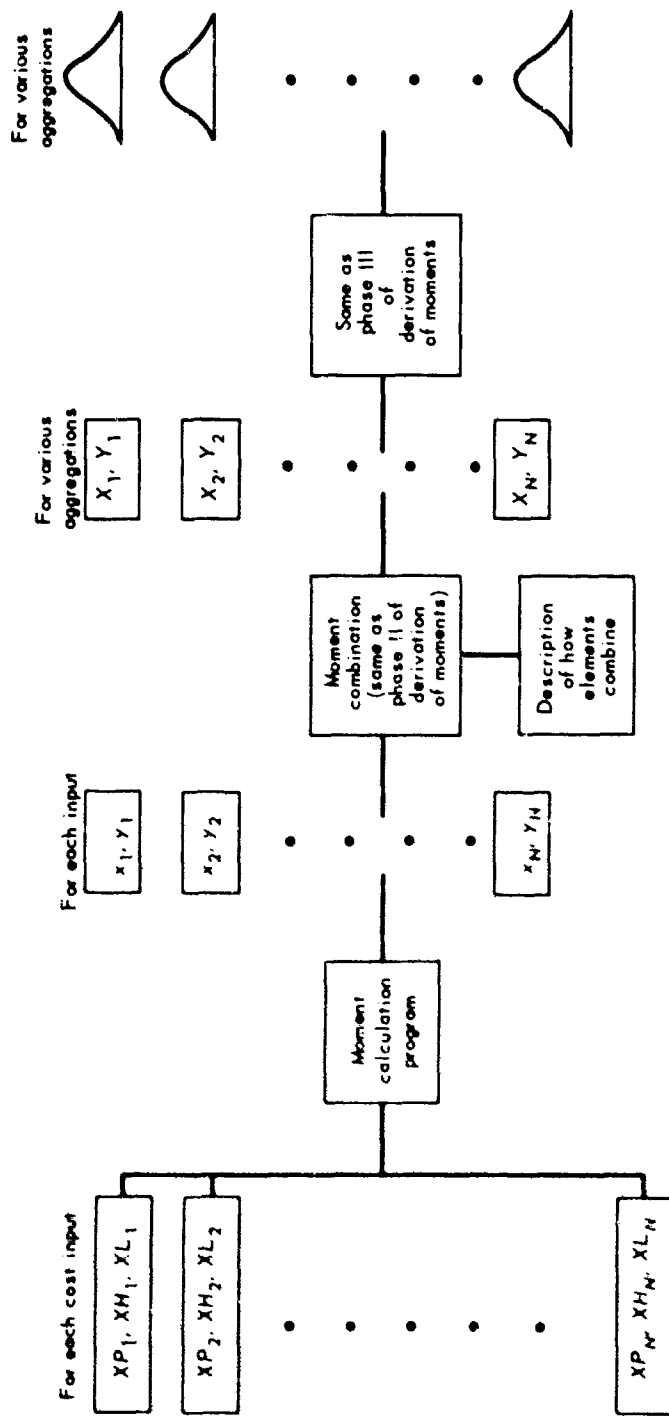

Fig. 12.—Symmetric-Approximation Techniq

$$x = \frac{XH + 4(XP) + XL}{6} \quad v = 0$$

$$y = \left(\frac{XL - XH}{6} \right)^2 \quad w = 0$$

3. Time required per iteration in the Monte Carlo technique could prove to be prohibitive for large-scale models. The other two seem quite reasonable in the consumption of computer time.

4. The symmetric approximation technique seems inadequate as it takes no account of any skewness. Analysts generally believe cost distributions to be skewed right. If this proves widespread, the error induced by this approximation will certainly prove more important than the simplification offered.

These statements are inconclusive and provide only the beginnings of a basis for evaluation. Once all techniques are operational, the evaluation of their relative merits and costs is the item of first priority for the future.

Sample Analysis for Large-Scale Cost Model

The approach to date has been operations rather than applications oriented. Thus the models developed were test cases containing considerably fewer equations than a typical Army application. Plans now are to apply the uncertainty techniques to a division cost model recently developed by the Cost Research Division of the Office of the Comptroller of the Army. In order to do this for the derivation of moments technique, plans are being formulated for a routine that will automatically link the ISOC format to that of the derivation of moments. This will give the derivation of moments technique the capability of processing existing cost models. This could be a determining factor in the final selection of techniques. At any rate a large-scale model consisting of 100 to 200 cost equations is the next target for application of these uncertainty analysis techniques.

Development of "Best" Set(s) of Distributions

The third area of study is a determination of the number and types of input distributions that would comprise a "best" set for use by analysts. It is, however, not clear that a single set could be chosen to handle all models in all cases. Perhaps instead a different set of distributions would be appropriate for different kinds of cost models. A paper⁵ now in process of publication introduces the concept of "families" of Army cost models. This paper proposes that the cost structure of each family such as aircraft systems models has certain standard characteristics even though individual models may vary in some details. The usefulness of such a framework for the definition of best sets will be studied. A final point pertaining to this selection is that criteria for choice do not seem obvious at all. At present we conceive of a method of testing these families of models with various distribution types, discussing results of these tests with other analysts, and perhaps coming to agreement on a set for different models. Thus at this point in time the area of definition of best sets of distributions seems an important though extremely difficult task.

CONCLUSION

Although much research remains to be done before these techniques can be properly evaluated and implemented, there is cause for optimism about their potential usefulness to both decision maker and analyst. Techniques such as these will not eliminate uncertainty from input data but can provide a powerful tool for decision making by measuring uncertainty in a way never before possible.

REFERENCES

1. John J. Surmeier, "An Individual System/Organization Cost Model," RAC-TP-183, Vol I, "Concept and Application," Research Analysis Corporation, 31 Aug 65.
2. Jodie T. Allen, "An Individual System/Organization Cost Model," RAC-TP-183, Vol II, "Computer Program Design and Operation," Research Analysis Corporation, 31 Aug 65.
3. S. A. Sobel, "A Computerized Technique To Express Uncertainty in Advanced System Cost Estimates," The MITRE Corporation, Sep 63.
4. Paul F. Dicnemann, "Estimating Cost Uncertainty Using Monte Carlo Techniques," The RAND Corporation, Jan 66.
5. A. D. Stament, "An Individual System/Organization Cost Model," RAC-TP-183, Vol IV, "Review of Selected Applications," Research Analysis Corporation, in preparation.