

AD 678173

What Industry Can Learn from R&D in  
Electronics and Electrical Maintenance Training

W. A. McClelland

NOV 26 1968

Mr. Baxter, Gentlemen, I'm grateful for the opportunity of being invited to speak to you today on this topic. It is a topic on which you, the audience, and I, the speaker, are both experts. We are, however, experts on different aspects of the problem of the training of electrical and electronics maintenance personnel. Each of us knows a great deal that the other does not know. As a psychologist, I am not at home on the engineering characteristics of hardware. I assume I wouldn't be here if you who are maintenance experts felt completely at home on the topic of how to teach people to become maintenance specialists.

This morning I hope to accomplish the following three things: (1) inform you of the kind of R&D we have accomplished for our major client, the US Army, in electrical and electronics maintenance training; (2) outline the approach we feel has been most effective in developing a systematic, generalized procedure for designing and testing training courses; and (3) suggesting, largely through subsequent discussion, how such work may be relevant to your own maintenance management operations.

By way of preface, let me say something about the organization which I represent, the Human Resources Research Office of The George Washington University. For the past 17 years HumRRO has been conducting training research for the Department of the Army, and more recently for the Post Office Department. Today, I'm only going to talk about one of the content areas in which we work, training research in electronics and electrical maintenance. (SLIDE 1) As a matter of interest, however, we are also doing research in the training of equipment operators, of new Army recruits, small unit training, training for leadership and command and control, language and area training, the technology of training, and finally, some basic research on the psychology of the learning process.

In order to give you a better feel for our maintenance training R&D, let me say a few words about the people and the equipment involved in Army maintenance. First, the soldier. As you know, the United States Army gets a fair portion of its input through selective service or the draft. Each soldier drafted is required to serve for two years. Because of the length of electronics maintenance training courses, however, relatively few draftees are eligible for such training. Some, however, do get technical training in mechanical maintenance - for example, the maintenance of tracked and wheeled vehicles.

Reproduced by the  
CLEARINGHOUSE  
for Federal Scientific & Technical  
Information Springfield Va. 22151

A paper presented to members of the Ford Motor Company's Master Maintenance Training Committee and other management personnel in maintenance operations at Dearborn, Michigan, on 25 June 1968.

This document has been approved  
for public release and sale; its  
distribution is unlimited.

The young man who enlists in the Army, however, serves a three-year tour of duty and is eligible for electronics maintenance training if he achieves an above-average score on a carefully developed classification test battery.

All men entering the Army must go through an eight-week period of basic combat training. Formal Army schooling follows successful completion of this instruction, and all of the electrical and electronics maintenance training courses on which HumRRO has done research have been given in formal Army school settings. The average student in this population has 11-plus years of formal schooling, is between 18 and 22 years of age, and has enlisted for a three-year tour of service. Many, but not all, have specifically asked for training in electronics. Career soldiers, those who are serving a second, third, or fourth period of enlistment, are definitely in the minority, for re-enlistment rates beyond the first tour rarely exceed 20% of any specific electronics maintenance career field.

Formal electronics maintenance training will range from 10 to 30 weeks in length depending on the nature of the equipment and the echelon of maintenance involved. Typically, the new graduate spends up to six months on the job, frequently as a member of a maintenance crew, before his commander rates him fully qualified as a repairman.

The jobs for which US Army maintenance men are trained tend to be specific and circumscribed. There are more than 80 different military occupational specialties involving electronics maintenance.

The US Army makes a distinction between direct support (or field) and organizational maintenance. Organizational maintenance generally involves overall maintenance of the system down to the level of the replaceable chassis. Some intra-chassis troubleshooting is authorized for the organizational maintenance man, but this generally is the task reserved for the direct support (or field) maintenance man who has available many more piece parts as well as special test equipment. In some instances the field maintenance man will be trained on a specific subsystem of a complex missile system, for example, the guidance package of a missile. Thus, he alone would not necessarily be responsible for repairing all chassis sent to his direct support unit by the organizational maintenance man.

Some repair, such as rebuilding chassis, has to be done at a rear echelon depot area. This work is often carried on by Department of Army civilian maintenance specialists rather than by enlisted personnel.

Upon completing an electronics maintenance course, the graduate is usually sent to an operational unit to perform the duties for which he was trained. The unit commander, however, has some latitude as to how he will use the man. The graduate may serve in a unit based in the continental United States or in any one of a variety of theatres in which US Army personnel are deployed. Some theatres conduct further formal training of the new graduate upon his arrival prior to assignment to an operational or direct support unit.

The kind of equipment for which formal electronics maintenance training is given covers a very broad range of size and complexity. A field radio repairman may be responsible for higher echelon maintenance of as many as 20 different radios. These vary from hand-held radios to those mounted in armored vehicles. But you, as engineers and maintenance experts, know more about the technical characteristics of radios and radars than I do. Other Army specialists may work on computers or missile guidance systems or carrier or microwave equipment or radars.

In its 17 years of existence, about 9% of the total HumRRO R&D effort has been in electronics maintenance training. In this work we have employed psychologists, engineers, an occasional physicist, and a goodly number of skilled electronics technicians. As with most of HumRRO's military training research, the subject matter expertise comes from specialists in the subject, while the scientist conceptualizes the problem, develops the research strategy, designs the study, and conducts and reports the study.

Let me now turn to the five major questions with which we have been concerned in the conduct of electronics and electrical training research.  
(SLIDE 2)

- (1) What does the man actually do on the job? What are the tasks he must perform, in what context, with what equipment and job aids? The research problem here is to develop techniques and procedures by which jobs can be accurately and efficiently described.
- (2) Assessment of proficiency, that is, how well can the graduate perform the task? How well does he perform after specified periods of experience on the job? The technical problem for the researcher is, of course, developing effective and efficient ways of assessing a man's capability to perform the job.
- (3) By what training methods and with what training media can the skills and knowledges required be most effectively taught? This is, of course, the main area of concern for most experimental psychologist - human learning.
- (4) What kinds of training aids, manuals, guides, and so forth, are most effective and in what form, in order to provide the essential technical support for the performance of electronics maintenance tasks?
- (5) How should the job be designed? What kinds of tasks should be grouped with what other kinds of tasks to make a military occupational specialty?

The major lesson we have learned in our studies of electronics maintenance training is the need for a systematic, generalized procedure for building and testing training courses. Systematic in order that all the many inter-

acting elements of a personnel and training subsystem are given appropriate consideration and weighting. Generalized so that the schema can be used in many very different kinds of Army courses, not just electronics training. Let me defer for later discussion details about the procedure we have evolved. I shall merely note now that there are seven steps in the procedure. They are: (SLIDE 3)

- (1) Determine performances required.
- (2) Derive training objectives from job performance requirements.
- (3) Base training content on training objectives.
- (4) Select appropriate training methods.
- (5) Administer training so as to minimize interference with learning and maximize learning principles.
- (6) Monitor the school-trained product.
- (7) Modify training as required.

At the risk of over-simplifying, let me summarize the essential nature of new thinking on electronics and electrical maintenance training by stating that the primary emphasis is placed on deriving content for training. Exactly how the content is to be taught follows more or less closely from the specific concept adopted. But there are some choices open to the course designer and instructor, for example, what instructional strategy to adopt, and how much of what goes into a book or manual and how much and what goes into the student's head.

The central theme of the most promising new concepts in electronics maintenance is to achieve better maintenance through improved structuring of the troubleshooting process. The concepts attempt to achieve better congruence of documentation (manuals, etc.), training and equipment. They imply modification of the personnel and training subsystem if people and money are to be effectively and efficiently utilized.

Does the foregoing imply existing training, current manuals and contemporary equipment design are inadequate - that people have not been doing their jobs well? Not at all. What is implied is this. To achieve better maintenance under current personnel and dollar constraints, we must take better advantage of those concepts and procedures known to be effective.

In the study of ten new electronics maintenance concepts, a HUMRRO team composed of Dr. E.L. Shriver, a research psychologist, Mr. Robert C. Trexler, an electronics engineer, and several technicians have found that all concepts seem to share a common view. This view holds that a better troubleshooting strategy together with the information needed to support it can be accomplished

by electronics experts using some type of equipment analysis. The strategy can be developed, in fact it must be developed, in advance of technician training. It can be presented to the technician via manuals, training or special display equipment. These concepts differ from the conventional approach in that they call for experts to make an equipment analysis for troubleshooting. This analysis is then transmitted to the repairman along with appropriate supporting data so that the repairman does not have to make analyses for himself, repeatedly, while he is troubleshooting. The concepts also imply bringing the equipment into congruence with the strategy. This involves test point identification and location, as well as configuration of parts into troubleshooting packages.

Having the analysis made once by experts results in reduced troubleshooting time. The experts must spend sizeable amounts of time making analyses of each circuit. It is easy to see how much of this adds to troubleshooting time when it is done over and over again by each man on the job - while the system is inoperative.

A phrase HumRRO has used both in electronics and in other training areas, functional context training or FCT, refers to one instructional strategy. Quite frankly, HumRRO researchers do not completely agree on all of the detailed procedures to be included under the functional context label. Most of us, however, do accept these features:

- (1) Establish a maintenance-oriented context.
- (2) Follow a whole-to-part sequence.
- (3) Present a graded series of job-related tasks.

First, a functional, maintenance-oriented context is clearly established for and prior to each block of instruction. At the beginning of a course, this can be accomplished by giving the student an orientation in the operation of the system (or equipments) he must learn to maintain. No theoretical material is presented except that which can be shown in performance terms to have applicability to the job which must be performed in the field.

Second, in teaching the equipment item, the various components are taken up in the same sequence in which they would be encountered by a maintenance man troubleshooting the equipment; that is, a whole-to-part sequence is followed.

Finally, the student is presented with a graded series of job-related tasks. Each task requires for successful performance that the trainee increase his knowledge of certain theoretical principles and/or that he acquire new skills. This is probably the most important feature of functional context training. By organizing the instruction around the progressive series of job-related tasks, several benefits can be obtained.

First, this organization greatly facilitates the successful implementation of the other two principles. If information is presented as it is required for the performance of some job-related task, the establishment of a meaningful maintenance-oriented context is assured. Also, organization of instruction around a progressive series of tasks usually means that each hardware item will be studied from the surface to the inside, not vice versa. Thus, the student encounters the various hardware parts in the sequence in which he will encounter them in troubleshooting.

A second advantage of this method of organizing the course is that it assures that the student is trained in the actual performance of job-related tasks. When instruction is organized on some other basis, there is a tendency to slight some of the job tasks and place perhaps too much emphasis on knowledge and skills which are thought to be necessary for job performance.

A third advantage of this approach to course organization is that the student is given a chance to apply each knowledge or skill soon after it is acquired. This helps the student to see that he is really learning to do a job, not just memorizing facts. And, it gives the instructor an opportunity to measure the student's ability to use the knowledges and skills he is acquiring.

I think you can see that functional context training is more than "hands-on training" and more than "whole-to-part training". Application of the FCT notion is still a matter of art, but where it has been used it has produced good results. And FCT has been used in such diverse subjects as mechanical, electrical and electronics training, radio code operator training, leadership training, college-level courses in statistics, and the training of medical corpsmen. Incidentally, FCT seems more effective with students of modest aptitude.

By now you have a better feel for the way in which HumRRO scientists feel training should be conducted in electrical and electronics maintenance. The next major question is "Does it work?" I'll attempt to answer this simply by saying that it does work in the contexts we have studied. Let me give you some evidence for this assertion. You can obtain more detailed information from HumRRO Technical Report 66-23, "A Description and Analytic Discussion of Ten New Concepts for Electronics Maintenance", by E.L. Shriver and R.C. Trexler, and from my own paper entitled "Psychological Research in Electronics Maintenance Training", copies of which are here in Ford offices.

In our most extensive series of studies which we have labeled task FORECAST, we have applied a technique for analyzing electronics systems conceptually so that a strict troubleshooting logic will hold throughout the system. This analysis, which we call cue-response, is made by expert maintenance personnel using the guidelines we have developed. It allows a block diagram approach to be effective for actual troubleshooting, for the cue serves as a straightforward and reliable indication of what troubleshooting procedure the repairman should follow. Some of our more important

findings in this effort are: (SLIDE 4)

- Effective job performance in three different studies. In one study proficiency was increased by 40%. In another graduates of a 12-week course performed as well as those in a 30-week traditional course.

(SLIDE 5) - Students trained on one subsystem of a fire control system were tested on another system on which they received very little training and yet performed quite well. This indicates FORECAST training can transfer across electronic systems.

- The study of electronics system mock-up equipment suggested that maintenance proficiency can be increased by the use of troubleshooting training devices if they are based on task analysis and are properly designed. Incorporation of such devices in training programs can reduce the requirements for more costly electronic equipment.
- FORECAST techniques can be successfully used to develop training content from the kinds of information available about new weapons systems before they are in production.
- Finally, we found that technicians can be taught to apply the FORECAST methods of equipment analysis. The materials they develop provide a basis for effective troubleshooting.

Several Army schools have adopted this technique for portions of their electronics training courses, particularly in the missile area. The US Navy adopted a two-week FORECAST-developed maintenance course for LORAN maintenance training with very satisfactory results. (SLIDE 6)

A somewhat different troubleshooting strategy was developed for training field carrier equipment repairmen. In Task JOBTRAIN the strategy selected was that of training electronics repairmen to recognize symptoms of mal-function much as a physician is trained to recognize the symptoms of illness. The physician does not base his diagnosis on the normal functioning of the human system, nor is he primarily concerned with the biological processes involved. He is, instead, skilled in noticing the distinctive and/or obscure symptoms that define the disease. It was necessary, of course, to develop job aids or manual materials which could be used to support the repair and troubleshooting activities of the electronics repairman.

Graduates of an experimental course were required to troubleshoot 18 mal-functions placed in various items of equipment during a six-day testing period. It appears that the combination of JOBTRAIN training and the job aids is as effective as conventional school training and conventional manuals. But the JOBTRAIN approach effects a 50% reduction in academic hours! (SLIDE 7)

A final illustrative HumRRO study, to which we gave the code name of MAINTRAIN, had the specific goal of developing an improved type of maintenance manual that would permit trained technicians to troubleshoot modern complex electronic systems faster and more accurately. We also specified the procedures for preparing such manuals. The experimental manual was prepared for use in troubleshooting a NIKE AJAX missile and its associated test equipment. Here's a sample page. (SLIDE 8) The manual was evaluated by means of a test in which trained technicians had to locate malfunctions in the equipment. Two groups of recent school graduates were required to locate 44 malfunctions in the system. 35 of the 44 items involved electronic malfunctions, and the remaining nine involved electrical malfunctions. (SLIDES 9 and 10)

The MAINTRAIN research has been subsequently elaborated, and a new task, Work Unit HAWKEYE, in which both the manual approach and functional context training techniques were applied. The data from our experimental tests support the value of the HAWKEYE approach, and it has been adapted for administration at the Air Defense School by Army personnel with very satisfactory results.

Perhaps a summary slide on the results obtained from studies of new concepts in electronics maintenance training would provide an overview of these findings. (SLIDE 11)

Obviously, HumRRO work in maintenance training has not answered all the questions which need answers. We still need research on ways to develop better instructional techniques and instructional aids. Still, if there are to be big advances in the efficiency with which electronics maintenance training is conducted, they are most likely to come through a study of the electronics maintenance system itself to include the structure of the organization in which maintenance must occur, the operational context in which maintenance must be done, the logistics support system and the personnel system designed to accomplish maintenance goals. We know more certainly than ever before that meaningful training must be considered in a larger context, as part of a larger system. One way to conceptualize this statement is depicted on this next slide. (SLIDE 12)

All of this leads up to the final and perhaps single most important question - "What is the relevance of this work to Ford Motor Company maintenance training?"

Clearly, I cannot give you an unambiguous answer to this question. Even if there was an answer, I just do not know enough about the Company's maintenance system to do more than offer suggestions in the form of "have you considered such and such?"

I have read through a number of documents which Mr. Baxter, Mr. Birdsall and Mr. Rauch provided me earlier this month and have found them both helpful and informative. Let me offer a few observations on what I understand from my reading.



First, it is obvious to me that the Master Maintenance Training Committee needs an organizational plan. A plan is needed for several reasons. Improvement of maintenance management requires detailed knowledge of company-wide training needs. You must know what the larger system requires of the plant engineering maintenance subsystems. Looking only at training needs, however, let me go back to one of my earlier points - what does the job require of the job incumbent - what knowledge, what skills, what attitudes and work habits? Need can be defined at many levels of generality. But if training is to be given to company employees there must have been a prior determination of its objectives in detailed performance terms, the determination being based on task analysis.

Training must be viewed in system terms, as I noted earlier (Slide 3). Once an effective and efficient training system is in being, be sure to provide for feedback from the job. Is the training meeting the job needs? In theory the Company appears to have provided for such feedback (Chapter 7 of the text for Course 3308, Managing Manufacturing and Assembly Plant Engineering).

There are probably several ways in which the training needs, once established, can be met. Trainee characteristics, available resources in training manpower and equipment, time available for training and so forth will have to be considered carefully when selecting a training strategy. Incidentally, there is a HumRRO publication available which discusses the topic of training systems more fully than I could possibly do this morning, HumRRO Technical Report 66-18, "The Design of Instructional Systems".

Obviously, you cannot generate all the detailed information on which to base training from your own resources. This is especially true for new equipment to be supplied to the Company by other manufacturers. We do know from our R&D activities, that it is possible to get such detailed information if the right questions are asked of suppliers. While a general statement of information needs can be written, it may well be necessary for company maintenance management to prepare additional detailed statements to supplement the general statement for individual items of equipment. The characteristics of employees and the interfaces of new with other equipment, for example, may vary from job to job. A close cooperative working arrangement between plant personnel and suppliers of new equipment can save a great amount of grief and money.

Take for example technical manuals. Perhaps the most important lesson HumRRO has learned with respect to the technical materials supplied by the Army is that all too frequently they are not written from the perspective of the man who must use them in performing maintenance. These materials are much more useful if prepared from the perspective of the maintenance man. All too frequently the engineers and technical writers do not adopt this perspective. HumRRO job aids and troubleshooting manuals are developed from this perspective, and much of the gain in proficiency that we have realized is because of this orientation. In summary, determine first what the man must do, then what he needs to know to do it and provide him with the job aids and manuals that he can use to do the task.

Although I did not study them as carefully as they deserve, the troubleshooting program for the radio-controlled crane seemed to me to be a first-class job from a teaching perspective. Our data indicate that similar self-instructional documents are superior to the more conventional manuals and troubleshooting aids. The reasons for this superiority lie in the fact that they were developed systematically with attention to the requirements for job-oriented content, simple display, organization of content according to a simple logic and verbal presentation in simple prose.

Let me summarize my observations very briefly. We have found that there is utility to the services of our R&D in electrical and electronic maintenance. I have some Army documents to substantiate this claim (USCONARC Utilization Pamphlets). We suspect this is largely due to a systematic way of developing training courses, and we also suspect the seven-step procedure I outlined has generality well beyond military training. Already civilian educational researchers and practitioners are using these same concepts in developing curricula in elementary and secondary education. I believe our philosophy of training technology is relevant to your own training needs and hope we can jointly pursue this belief in discussion.

Thank you. Are there any questions?

# HumRRO...

is responsible for conducting studies and research in training, needs for training devices, motivation, and leadership as mutually agreed upon by the Department of the Army and HumRRO.

Slide 1

## Five Research Questions

1. What does the man do on the job?
2. How well does he do it?
3. How can he be taught most effectively?
4. What job aids and manuals does he need?
5. How should the job be designed?

Slide 2

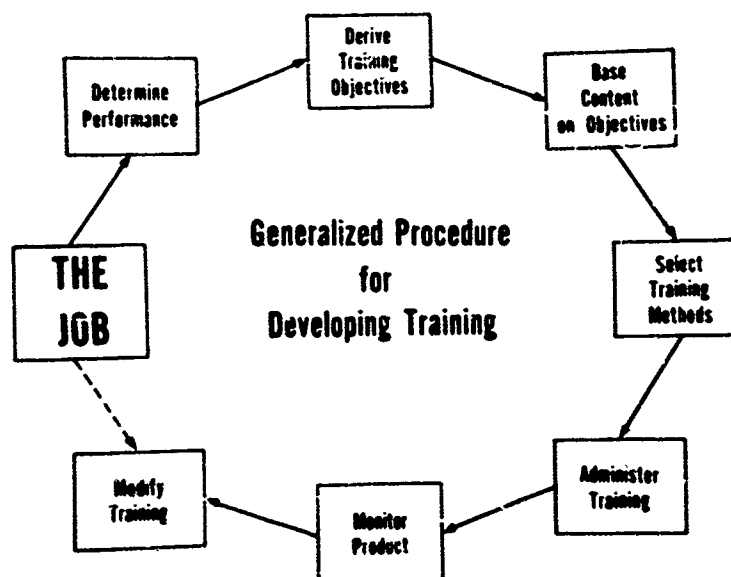

Slide 3

## FORECAST

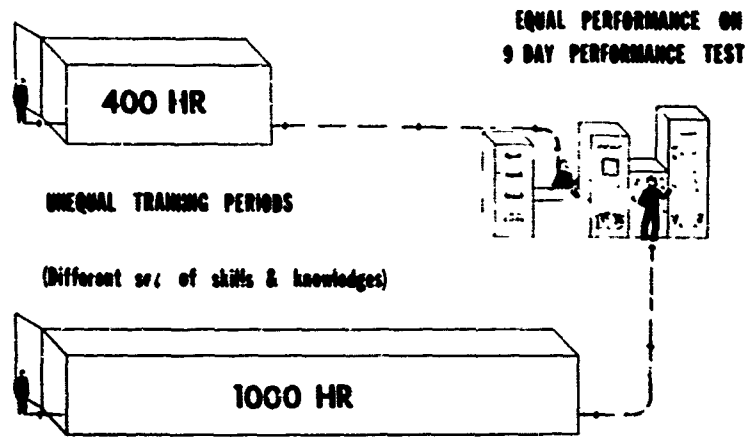

Slide 4

## FORECAST Results

1. Performance Proficiency Increased 40%
2. Training Time Reduced 50%
3. Training Transfers From One System to Another High
4. Medium Fidelity Training Devices Saving in use of real hardware
5. Training Program Forecasted and Students Trained Before Hardware Reaches Field

Slide 5

# LORAN Test: Covering Problems C, D, E, F, G, H, J, & K

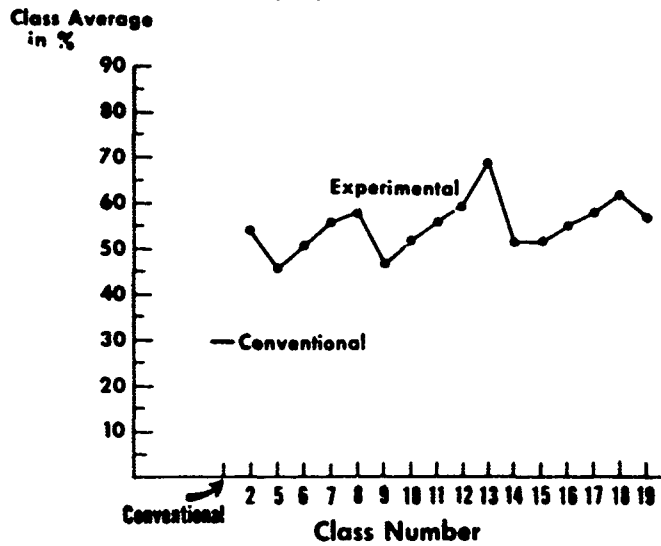

Slide 6

## NUMBER & PERCENT OF PROBLEMS SOLVED BY TRAINEES IN SCHOOL & JOBTRAIN CARRIER EQUIPMENT COURSES

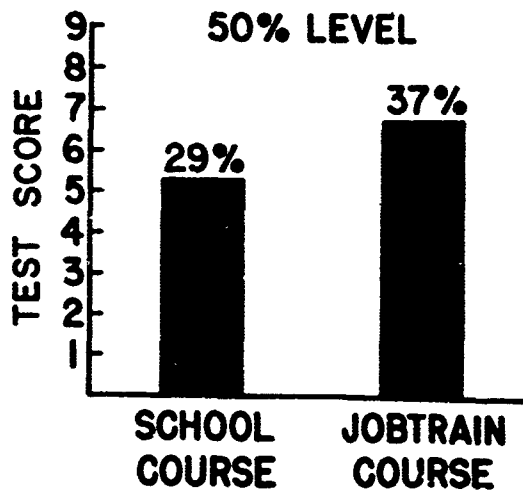

Slide 7

### Experimental Manual: Sample Written Instructions and Data-Flow Diagram

CONDITIONS	SYMPTOM	CHECK	INDICATION	CHECK	INDICATION	CHECK	INDICATION
48 RESPONSE ON VOLTAGE WAVE TS51 REC SVRS		PC1 VEAU TS11 W/ TEST 112 T/2S1 00-02 ATTN-08 ADJUST W/ 120 DUTY AND	IF POWER MOTOR does not read 0	TS11 W/ TEST 512 PC1 VEAU T/2S1 00-05 Adjust ATTN-08 Knob and REFLUX Knob for satellite Indication toward 0	IF POWER MOTOR reads between 0 and 2	TS11 OWN 512 CCSI NEAS Operate RIGHT W/ WELL 1 second and turn operate STAMP W/ *	Slow down around equal value and stop after 1/2 to 0/3 milliseconds
			IF POWER MOTOR reads 0	TS11 TRAND TEST PC1 VEAU T/2S1 missile code	IF POWER MOTOR does not read between 0 and 2	TS11 CODE 512 CCSI NEAS TAA OKKALDI → 2	

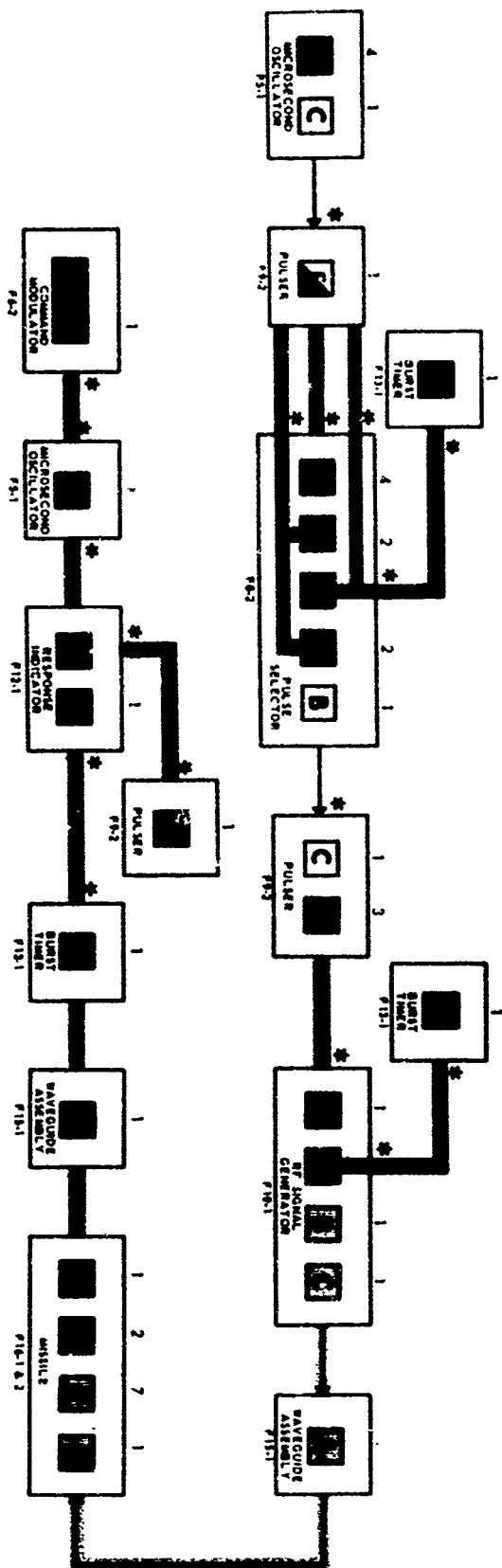

### Test Results-Electrical Malfunctions

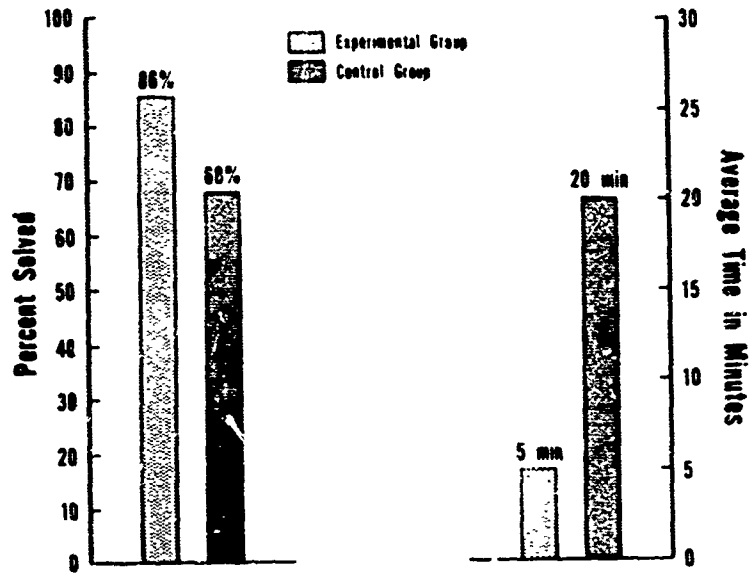

Slide 9

### Test Results-Electronic Malfunctions

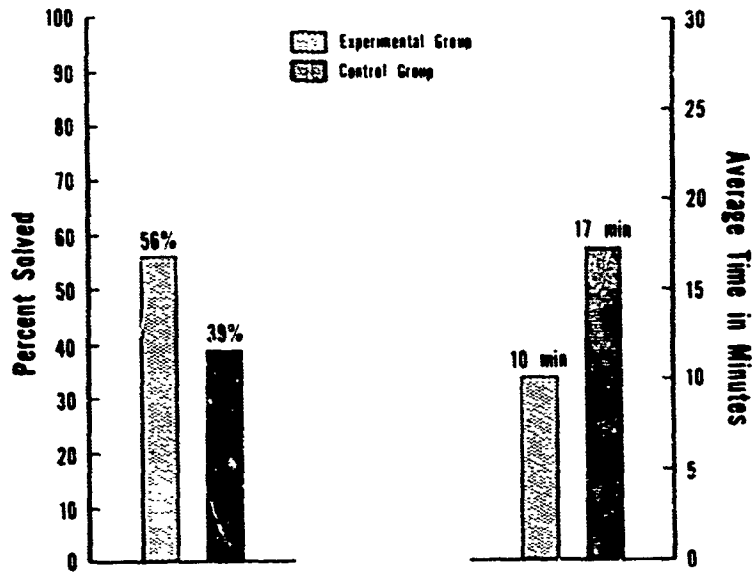

Slide 10

### Tests of Concepts With Military Subjects

Concept	Test Duration	Number of Malfunctions	Statistical Significance	Number of Subjects	Results
<b>FORECAST</b>					
I	9 days	120	No significant difference	37	Equal performance 60% less training time
II	2 days	30	.01	16	40% higher performance 50% less training time
III	NA	NA	NA	Continuing Course	Produced manuals, course, & training equipment before production equipment available
<b>LORAN</b>					
	1 day	0	00001	90 (Continuing Course)	200% higher performance Same time
<b>JOBTRAIN</b>					
	6 days	10	No significant difference	30	Equal performance 50% less training time
<b>MAINTRAIN</b>					
	1/2 day	31	.10	16	40% higher Same time
<b>SIMS</b>					
	1 day	3		42	36% higher Same time
<b>Modified A VIS</b>					
	3 days	45	.05	15	40% higher Same time

Slide 11

### TRAINING AS PART OF A LARGER SYSTEM

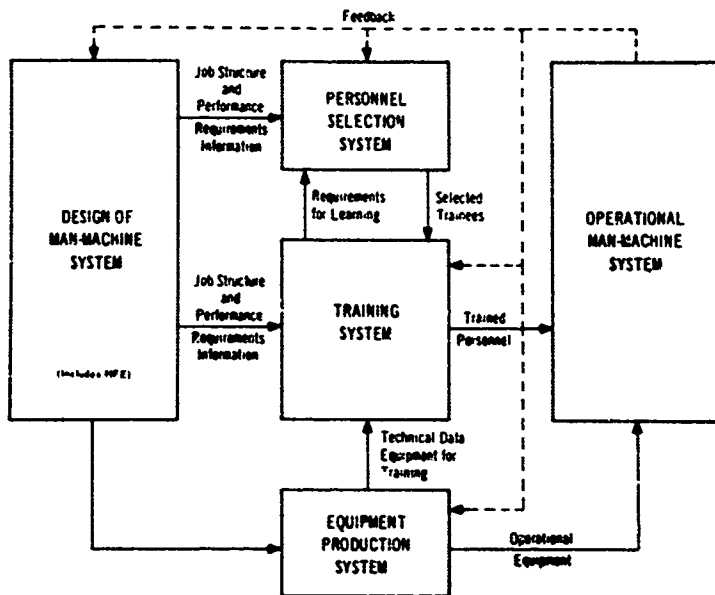

Slide 12