

TECHNICAL REPORT

89-19-CM

ADAD 677384

# A STUDY OF HOT-STRETCHING TRANSPARENT PLASTICS

by

Allen S. Powell, Russell W. Ehlers,  
and Stephen A. Orroth, Jr.

Lowell Technological Institute Research Foundation  
Lowell, Massachusetts

Contract No. DA19-129-AMC-844 (N)

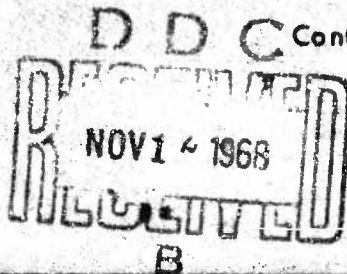

July 1968

UNITED STATES ARMY  
NATICK LABORATORIES  
Natick, Massachusetts 01760



Clothing & Organic Materials Laboratory  
C&OM-53

This document has been approved  
for public release and sales its  
distribution is unlimited

18

This document has been approved for public release and sale; its distribution is unlimited.

The findings in this report are not to be construed as an official Department of the Army position unless so designated by other authorized documents.

Citation of trade names in this report does not constitute an official indorsement or approval of the use of such items.

Destroy this report when no longer needed. Do not return it to the originator.

This document has been approved  
for public release and sale;  
its distribution is unlimited.

AD \_\_\_\_\_

TECHNICAL REPORT

69-19-CM

A STUDY OF HOT-STRETCHING TRANSPARENT PLASTICS

by

Allen S. Powell  
Russell W. Ehlers  
Stephen A. Orroth, Jr.

Lowell Technological Institute Research Foundation  
Lowell, Massachusetts

Contract No. DA 19-129-AMC-844(N)

July 1968

Project References:  
1P121401A150  
1C024401A329

Series: C&OM-53

Clothing and Organic Materials Laboratory  
U. S. ARMY NATICK LABORATORIES  
Natick, Massachusetts 01760

## FOREWORD

Hot-stretching of plastic films and sheets is known to improve strength properties. It is commercially applied to many films for packaging purposes. Biaxially stretched acrylic is the only commercial application for sheet. It is used in aircraft glazing where shatter-proofness and craze-resistance are required. In a study supported by these Laboratories about a decade ago, the ballistic limit of nylon film was found to be substantially increased by uniaxial hot-stretching and even more by biaxially stretching. With the renewed interest in transparent armor, hot-stretching offers the possibility of improving the ballistic penetration resistance of commercially available polymers.

The work performed by the Lowell Technological Institute Research Foundation, under the guidance of Dr. Allen Powell, was intended to determine the potential of hot-stretching in improving polymers for fragment and bullet-resistant armor. This report covers only hot-stretching and its effects on the physical properties of the polymers. The ballistic evaluation was conducted by the U. S. Army Natick Laboratories and its correlation with hot-stretching variables will be reported in a separate report.

The Project Officer for the U. S. Army Natick Laboratories was Anthony L. Alesi and the alternate Project Officer was Roy C. Laible.

## CONTENTS

	<u>Page</u>
List of Tables	vi
List of Figures	vii
Abstract	viii
1. Introduction	1
2. Literature Survey	2
a. Information from Suppliers	10
3. Uniaxial Stretching Trials	11
a. Equipment	11
b. Materials	13
c. Ranges of Test Parameters	13
d. Samples Prepared	14
(1) Polystyrene	14
(2) MIL-P-8184 Acrylic	15
(3) Polycarbonate	15
e. Results of Tests on Uniaxially Stretched Plastics	15
(1) Polystyrene	16
(2) MIL-P-8184 Acrylic	19
(3) Polycarbonate	19
f. Uniaxial Screening Trials	23
(1) Polypropylene	23
(2) Nylon 6	25
(3) Delrin	25
(4) Celcon	27
g. Physical Test Check Results on Commercial Biaxially Oriented MIL-P-8184 Acrylic	27
4. Biaxial Hot Stretching Equipment	29
a. Equipment Design	29
(1) Heating System	29
(2) Housing	34
(3) Stretching Rate Control	34
(4) Sample Clamping	36
(5) Birefringence Observation	36

CONTENTS (Cont'd)

	<u>Page</u>
b. Equipment Modification	36
(1) Temperature Control Improvements	36
(2) Mechanical Equipment Improvements	37
5. Biaxial Stretching Trials	38
a. Plastics Evaluated Extensively	39
(1) Hot-Stretching of Polystyrene	39
(a) Physical Test Results for Polystyrene	39
(b) Optical Test Results for Polystyrene	44
(c) Materials Delivered	44
(2) Hot-Stretching of Polycarbonate	46
(a) Physical Test Results for Polycarbonate	47
(b) Optical Test Results for Polycarbonate	51
(c) Materials Delivered	51
(3) Hot-Stretching MIL-P-8184 Acrylic	51
(a) Physical Test Results for MIL-P-8184 Acrylic	53
(b) Optical Test Results for MIL-P-8184 Acrylic	53
(c) Materials Delivered	57
(d) Effect of Hot-Stretching Variables on the Crack Propagation Test Results	57
b. Screening of Other Plastics	59
(1) Cross-linked Polyethylene	59
(2) Polypropylene	60
(3) Nylon 66 and 6	60
(4) Polysulfone	60
(5) Polyphenylene Oxide	61
(6) Plexiglas IA UVA	61
(7) Modified Acrylic XT500	63
6. Conclusions	64
7. Recommendations	65
8. Selected Bibliography	66

## LIST OF TABLES

		<u>Page</u>
I	The Investigation of Multiaxially and Biaxially Stretched Acrylic Plastic	3
II	Physical Properties of Uniaxially Stretched Polystyrene	17
III	Physical Properties of Uniaxially Stretched Acrylic	20
IV	Physical Properties of Uniaxially Hot-Stretched Polycarbonate	22
V	Physical Properties of Uniaxially Stretched Nylon 6	26
VI	Physical Properties of Biaxially Oriented Acrylic Sheet Supplied by U. S. Army Natick Laboratories	28
VII	Physical Properties of Biaxially Hot-Stretched Polystyrene	40
VIII	Optical Properties of Biaxially Hot-Stretched Polystyrene	45
IX	Physical Properties of Biaxially Hot-Stretched Polycarbonate	48
X	Optical Properties of Biaxially Hot-Stretched Polycarbonate	52
XI	Physical Properties of Biaxially Hot-Stretched MIL-P-8184 Acrylic	54
XII	Optical Properties of Biaxially Hot-Stretched MIL-P-8184 Acrylic	56
XIII	Stretching Conditions and Crack Propagation Test Results for Plexiglas IA UVA	62
XIV	Crack Propagation Test Results for Modified Acrylic XT500	63

## LIST OF FIGURES

		<u>Page</u>
1	Clamp Designs for Hot-Stretching Plastics	12
2	Distribution of Thicknesses on the Crack Propagation Samples	18
3	Distribution of Thicknesses on the Crack Propagation Samples	21
4	Distribution of Thicknesses on the Crack Propagation Samples	24
5	Biaxial Hot-Stretching Equipment	30
6	Frame for Plastic Stretching Device	31
7	Plastic Stretching Device	32
8	Heating System for Plastic Stretching Device	33
9	Hot-Stretching Unit	35
10	Effect of Hot-Stretching Variables on Crack Test Results	58



## ABSTRACT

The effect of hot-stretching parameters on the uniaxial and biaxial orientation, physical properties and optical properties of transparent plastics was investigated. Stretching parameters included draw temperature, rate of drawing, percent stretch and rate of quenching from drawing temperature. Plastics on which complete evaluation of physical and optical properties was made were polystyrene, polycarbonate and MIL-P-8184 polymethyl methacrylate. Limited screening evaluation of the hot-stretching behavior of cross-linked polyethylene, polypropylene, nylon 6, nylon 66, Delrin (R), Celcon (R), polyphenylene oxide, polysulfone, Plexiglas 1A (R) and XT500 modified acrylic was performed uniaxially and/or biaxially. Substantial amounts of biaxially stretched sheet 1/8-inch, 1/4-inch and 1/2-inch thick were supplied to the U. S. Army Natick Laboratories. Laminated panels of hot-stretched polystyrene, polycarbonate and MIL-P-8184 acrylic sheets were also submitted for ballistic resistance tests.

Acrylic materials were found to be more amenable to hot-stretching than other plastics. No clear correlation between stretching parameters and improved physical properties was found. A versatile hot-stretching unit and a process technology to apply it were developed.

## 1. Introduction

A study of the hot-stretching behavior of transparent plastics and the properties of materials prepared by hot-stretching was conducted. The basic purpose of the work done was the development of a transparent plastic with optimum ballistic resistance by suitable control of the hot-stretching parameters rate of stretch, percent stretch, rate of quenching and temperature of material during stretching. Both uniaxial and biaxial stretching were investigated.

The work program had six parts:

a. The effect of hot-stretching procedures on the ballistic resistance of laminated and bonded assemblies was to be determined. The four parameters just mentioned were to be studied for both uniaxially and biaxially stretched sheet materials.

b. The physical characteristics of the hot-stretched plastic sheets were to be determined. Shrinkage on heating, orientation release stress, crack propagation and toughness, impact strength, optical transmittance, haze, displacement of line of sight and distortion were to be tested for the three materials listed below.

c. Quantities of sheet material biaxially stretched to various thicknesses were to be prepared from MIL-P-8184 polymethyl methacrylate, polystyrene and polycarbonate. Ballistic test panels also were to be laminated from these three materials. These pieces of material were to be shipped to the U. S. Army Natick Laboratories.

d. Six or seven additional polymers were to be screened by biaxial stretching to identify promising materials for further work. These polymers were to be evaluated by crack propagation and toughness tests.

e. Samples of these additional polymers not consumed in testing were to be supplied to the U. S. Army Natick Laboratories along with any tested material which might be requested.

f. This final report with conclusions and recommendations was to be submitted to the U. S. Army Natick Laboratories.

Chronologically, the elements of work performed were a brief literature survey to determine those materials which had been hot-stretched, conditions used for stretching and results obtained, uniaxial stretching of plastics, design and fabrication of a hot-stretching unit, biaxial stretching of plastics for evaluation and delivery, testing of plastics and preparation of the final report.

The initial ideas on which the hot-stretching program was based were taken from the known behavior of acrylate polymers. The behavior of other polymers was found to differ markedly from the acrylates.

A very great experimental problem also arose because the hot-stretching equipment design was based on results from uniaxial stretching work. The stretching behavior under biaxial stresses has been found to be very much different from uniaxial stretching. This difference seems to arise from the reinforcement developed in the plastic sheet by the process of biaxial stretching. Forces several orders of magnitude greater than those in uniaxial stretching are required to stretch biaxially. As a result of this problem, a great amount of time and expense was needed to modify the hot-stretching unit during the period of contract performance.

It also became evident during uniaxial stretching experiments that the concepts of parametric variables and testing which had been based on work done with thin sheets of biaxially stretched polymethyl methacrylate would not be applicable to other plastic materials. In fact, the crack propagation, toughness "K" factor test seems to be unique to acrylic resin materials. The reason for this uniqueness is not immediately apparent. Tensile and elongation data were substituted for crack propagation tests in this project with the consent of the Project Officer.

As a result of findings, it seems that a broader approach with a more fundamental look at material properties and their variation as a result of hot-stretching should be used for development of improved ballistic resistance in hot-stretched plastics.

## 2. Literature Survey

A search was made for informative papers on hot-stretching of plastics after initiation of the contract.

Only a limited number of applicable references could be found. Information on conditions used and equipment design was often not given. Table I shows the information obtained. General conclusions from the reports examined are that most effort has been applied to acrylic plastics, that most plastics will have increased strength; in some cases, several-fold increases in impact resistance were found; degree of extension was usually 50 to 100 percent; and operating temperatures were closely controlled in the range giving rubbery behavior.

The published data also indicate that MIL-P-8184 acrylic cannot be stretched as much as 100 percent but that impact and ballistic resistance are greatly improved at 80 percent elongation. Acrylic

Table I

## THE INVESTIGATION OF MULTIAXIALLY AND BIAXIALLY STRETCHED ACRYLIC PLASTIC

Sample Acrylics MIL	Initial Sample Thick- ness (Inches)	Operating Temperature	$\Delta$ Time	Percent Stretch	Type of Clamping	Remarks
P-5425A	.375	135° ± 3°C	3'-6"	25,50,75,100	Vacuum Clamps, also hollow	When sheets stretch 100% x 50% and 100% x 100%, Impact Strength was greatest increase 4x.
	.500					
	.750	135° ± 3°C				
	1.000					
P-8184	.375	135° ± 3°C	3'-6"	25,50,75	Clamps Stuffed with Wet Rags	Impact Strength = 3x
	.500					
	.750	135° ± 3°C		Tore at 100		
	1.000					
P-6886A	.375	120° ± 3°C	3'-6"	50,75,100		Impact Strength = 6x
	.500					
	.750	120° ± 3°C				
	1.000					

After stretching, each sample was cooled with ice-chilled air for 10-15 minutes.

Preheating of each sample 3/4-1 hour or about 100 minutes per inch thickness.

Preheating time for each sample was longer than the actual stretching time.

The stretching equipment was preheated 40-45 minutes prior to stretching.

Stretching rate was 2-1/2 inches per minute.

Each sample was stretched different amounts in each direction.

Abrasion resistance in all samples decreased.

All samples were stretched to 1/4-inch thickness.

Table I (Cont'd)

BIAXIALLY STRETCHED ACRYLIC PLASTIC

<u>Sample</u>	<u>Sample Thickness (Inches)</u>	<u>Operating Temperature</u>	<u>Δ Time</u>	<u>Percent Stretch</u>	<u>Clamping</u>	<u>Remarks</u>
Gafite CO		166°C-170°C		45, 60, 80, 100	Vacuum clamps also hollow	Stretch rate 2.5 in/min. Impact Strength increased with increase in percent stretch.
Gafite CX0		166°C-170°C		45, 60, 80, 100	Clamps stuffed with wet rags	
MIL-P-8184	1/4" Final	135°C-145°C 154°C		80, 50, 70, 60		Stretch speed 2.5 to 13 in/min. best speed 7-11 in/min.
MIL-P-5425		135°C-145°C		80, 70, 90, 60		Stretched at 2.5 in/min. to 13 in/min.

No evidence found that stretching temperature, stretching rate had a significant effect on crack propagation resistance tests.

Gunfire resistance of 80 percent stretched MIL-P-5425 and MIL-P-8184 was greatly superior to that for unstretched materials.

Gafite = Polymethyl Alpha Chloroacrylate

Table I (Cont'd)

## BIAXIAL STRETCH-FORMING OF ACRYLICS

<u>Sample</u>	<u>Sample Thickness (Inches)</u>	<u>Operating Temperature</u>	<u>Rate of Δ ε Cooling</u>	<u>Percent Stretch</u>	<u>Clamping</u>	<u>Remarks</u>
Lucite Gen. Purpose HC-201	0.15	130°C		100-145	Vacuum Forming	Tensile strength increased 6% when sample stretched 150%; none for 100%
Lucite Δ Resistant of HC-202	0.15	160°C	NO DATA GIVEN	100-150	Vacuum Forming	Broke prematurely - no strength data given
Flexiglas I-A Gen. Purpose	0.15	130°C	NO DATA GIVEN	165-170	Vacuum Forming	Twelve percent increase in T.S. for samples stretched 165-170 percent
Flexiglas II Δ Resistant	0.15	160°C		100-150	Vacuum Forming	Same as for Plexiglas I-A, no increase in T.S. for stretches under 100 percent

Abrasion resistance in all stretched samples decreased.

Light transmission decreased slightly and hazing increased 15-55 percent.

Sample sizes and heating and cooling data not given.

Table I (Cont'd)

## EFFECTS OF MULTIAXIAL STRETCHING ON CRAZING

<u>Sample</u>	<u>Sample Thickness (Inches)</u>	<u>Operating Temperature</u>	<u>Δ Time</u>	<u>Percent Stretch</u>	<u>Type of Clamping</u>	<u>Remarks</u>
Lucite HC-222 MIL-P-5425A	1/4" 36"x48"	165°C	30 min.	50, 100, 150	Vacuum Clamping or	Multiaxial stretching used. Tensile strength slightly increased. Rapid cooling but no data given. Tensile strength slightly increased.
Plexiglas 55 or MIL-P-9184	1/4" 36"x24"	185°C 160°C-185°C	30 min. 15'-30'	45, 85, 45, 85	Vacuum Forming	Not possible to stretch this material more than 85% with equipment used. T. S. slightly increased.
Gafite Poly- methyl Alpha Chloroacrylate	1/3" 36"x60"	180°C	30 min.	50, 150		Significant increase in tensile strength.
Resin C	1/4" 36"x48"	180°C 180°C Bubble de- veloped when heated for 30 min.	15 min. 30 min.	50-100		Good improvement in tensile strength.

Multiaxial stretch decreased abrasion resistance. The amount of resistance decreases as degree of stretching increases. In unstretched specimens, heating and rapid cooling had no significant effect on tensile stretch. Annealing increased tensile strength in some specimens. Annealing increased tensile strength in all stretched specimens. Annealing did not affect surface abrasion resistance of stretched samples. The polymethyl alpha chloroacrylate samples showed the largest increase in tensile strength after stretching. The samples were heated to the forming temperature, placed over vacuum former and stretched in a circulating air oven.

Table I (Cont'd)

## EFFECTS OF BIAxIAL STRETCH-FORMING

<u>Sample</u>	<u>Sample Thickness (Inches)</u>	<u>Operating Temperature</u>	<u>Δ Time</u>	<u>Percent Stretch</u>	<u>Clamping</u>	<u>Remarks</u>
Lucite HC-201	0.12 - 0.15	130°C 120°C		60, 54	Vacuum-formed disks 10" diameter	Stretched uniaxially.
Lucite HC-202	0.12 - 0.15	140°C		57		
Plexiglas I-A	0.12 - 0.15	120°C		59		
Plexiglas II	0.12 - 0.15	140°C		50		

No heating or cooling data given. Tensile strength in all samples improved.



Table I (Cont'd)

STRETCHED ACRYLIC FOR HIGH SPEED AIRCRAFT

<u>Sample</u>	<u>Sample Thickness (Inches)</u>	<u>Operating Temperature</u>	<u>Δ Time</u>	<u>Percent Stretch</u>	<u>Clamping</u>	<u>Remarks</u>
MIL-P-5425A	1/2"	85°C 110°C		104	Kindelberger jaws and	NONE GIVEN
P-P184	1/2"	85°C 121°C		82-85	curved jaws	NONE
Polymethyl Alpha Chloroacrylate		Cool to decomposition temperature around 116°C				NONE

Heating and cooling data not given.  
Multiaxial also tried.

Close control of temperature and rate of draw were not maintained. The "Kindelberger jaw" clamps were not practical - they tore the samples.

Table I (Cont'd)

## ORIENTED THERMOPLASTIC SHEET AND FILM

Sample	Thick- ness (Inches)	Operating Temperature	$\Delta$ Time	Percent Stretch	Clamping	Remarks (T.S. = Tensile Strength)
Polyethylene	0.001 0.015			100-300	Jaw Clamps	Impact and tear strength lowered: 100% stretch doubled T.S., 200% stretch tripled T.S.
Polystyrene	0.001 0.015			10-20	Jaw Clamps	Biaxial stretching increased tensile strength 7-12%.
Styrene Acrylonitrile	0.001 0.015			40-60	Jaw Clamps	Tensile strength increase not given.
Acrylic	0.001 0.015			60-80	Jaw Clamps	T.S. increased 8-11%.
Polycarbonate	0.001 0.015			Up to 200	Jaw Clamps	T.S. doubled.
Polyethylene Terephthalate	0.001 0.015			35-110	Jaw Clamps	T.S. increased 17-24%.
Saran	0.001 0.015			20-120	Jaw Clamps	T.S. increased 8-20%.
PVC	0.001 0.015			200	Jaw Clamps	T.S. doubled.
Rubber Hydro- chloride Film	0.001 0.015			200-800	Jaw Clamps	T.S. increased 3-5%.

plastic tensile strength is not greatly increased by hot-stretching and therefore is not a useful test for optimizing the stretching process. Data for polyethylene, polycarbonate, and polymethyl alpha chloroacrylate, on the other hand, show significant tensile strength improvement by hot-stretching.

Equipment design was based on an upper temperature limit of 200°C, ability to vary stretching rates from about 0.01 to 20 inches per minute, and ability to control temperature to  $\pm 3^\circ\text{C}$  with very even distribution over the full sample area.

Selected bibliography is listed in Section 8. Information obtained from suppliers of plastic raw materials is given below.

a. Information from Suppliers

Contacts were also made with representatives of two suppliers of plastic raw materials. Information on behavior of materials and improvement of properties was discussed.

Work on a related project at Rohm and Haas, according to Pierson\*, showed that polymethyl methacrylate is very sensitive to notch effects at edges and tears on stretching, that heating and cooling of sheets one-inch thick are very slow and that cooling at stretching clamps may produce very high local stresses.

Pierson recommended preheating samples in an oven separate from the stretching unit and allowing 10 minutes heating time per tenth inch of sheet thickness. He also recommended sanding all samples along the edges parallel with the edge. He thought it might even be necessary to finish the clamping pin holes.

Rohm and Haas was able to stretch MIL-P-8184 acrylic up to a maximum of 65 percent at 12 inches per minute through evolution of technique and optimizing of clamp spacing and design.

According to Foster\*\*, Mobay Chemical Company supplies raw materials but does not fabricate sheets or blocks of polycarbonate. To his knowledge, there is no present source of optical quality sheet above three-eighths-inch thick.

\* Pierson, Orville. Personal Communication. Rohm and Haas, Philadelphia, Pa., April 11, 1967.

\*\* Foster, William E. Personal Communication. Mobay Chemical Company, Pittsburgh, Pa., June 27, 1967.

Foster said that polycarbonate sheet can be prepared by extrusion of compression molding and can be press-polished to optical quality.

In regard to the concern about imperfections and bubbles in sheet material, he offered these comments:

"Effect of water vapor at 160°C to 175°C under the conditions discussed should be negligible. Longer drying is recommended through storage in a low temperature dryer followed by 96 hours at 120°C just prior to stretching trials. Also, 160°C to 175°C is well above the flow point of polycarbonate and leads to yellowing. Ballistic testing has shown that lamination of thin layers will give better resistance than monolithic blocks."

### 3. Uniaxial Stretching Trials

It was initially felt that trials of uniaxial stretching would give much useful information for the design of hot-stretching fixtures for biaxial stretching trials. The results obtained have borne out this feeling and have been more useful than had been anticipated. The equipment, materials, techniques, and results of the uniaxial trials are shown below.

#### a. Equipment

A Tinius Olsen Universal Testing Machine and an Aminco Controlled Temperature Cabinet were used for the uniaxial stretching trials.

The Testing Machine provided controlled cross head speeds up to 20 inches per minute and had a maximum load capacity of 12,000 pounds. Stress-strain curves for stretching could be recorded.

The thermostatic cabinet had windows for observation of the specimen being stretched, ports to permit introduction of thermocouple or other instrumentation leads, and provision for both heating and cooling the samples.

A reflection polariscope with camera attachments for recording patterns of birefringence was set up using aluminum foil behind the sample as a reflector.

The initial design for holding samples during stretching was set up to simulate a design suitable for biaxial stretching trials. It consisted of a set of swinging arms pivoted on pins which passed through holes drilled in the plastic specimen on one end and on bolts through a metal channel at the other. This design is shown in Figure 1-A.

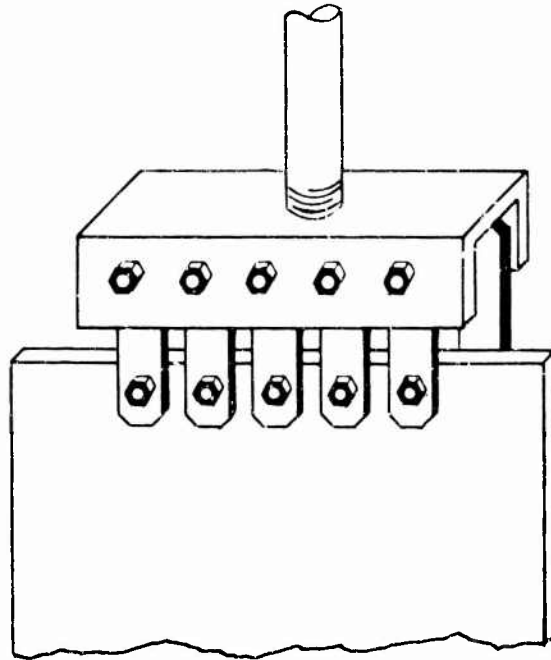

A CLAMPING DEVICE  
( INITIAL DESIGN )

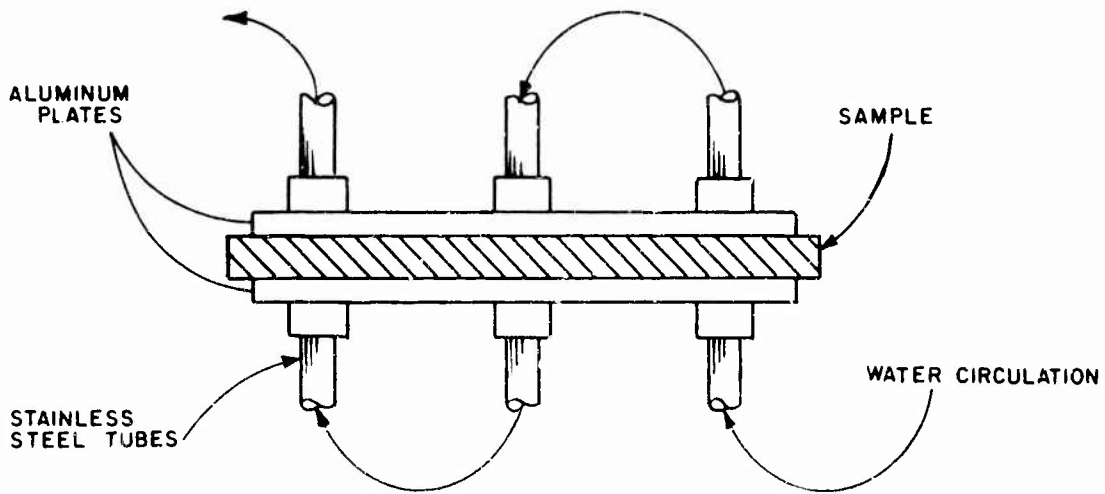

B CLAMP USED FOR UNIAXIAL TESTS

CLAMP DESIGNS FOR HOT-STRETCHING PLASTICS

FIGURE 1

It was found that considerable stretching occurred at the holes in the plastic when the clamp shown was tested. After several attempts at modification, it was found that replacement of the solid pins with stainless steel tubes through which water was circulated eliminated stretching and tear out of the holes in the plastic. While this scheme was used for biaxial stretching, the stress pattern near the holes through the uniaxial test specimens became unsymmetrical. To obtain the maximum useful test piece, the system shown in Figure 1-B was selected. Only three tubes on a six-inch span were required to cool the plastic and aluminum plates. A four-by-six-inch span in a six-by-six-inch test piece could be stretched evenly by this device.

#### b. Materials

Initial plans for uniaxial stretching were to use one-quarter-inch-thick pieces of plastic because it was thought that the modulus of the materials would be so high that thicker materials could not be stretched within the capacity of the Tinius Olsen Machine. Preliminary trials showed that the rubbery state of the three plastics chosen for test, polystyrene, polyacrylate and polycarbonate, had modulus values well within the capability of the Tinius Olsen, even for one-inch-thick pieces. In fact, tensile breaks have been experienced in many trials at 10 to 20 percent of machine capacity.

Trials of hot-stretching were, therefore, made on six-inch squares of all three plastics at both one-quarter-inch and one-inch thicknesses.

#### c. Ranges of Test Parameters

In the interest of conserving time and materials during biaxial testing, the uniaxial trials were designed to establish the range of parameters most likely to be satisfactory for biaxial work.

The temperature range for initial stretching was determined by selecting a lower temperature based on the glass transition of the material and an upper temperature at which the sample elongated under its own weight or lost so much strength in tension that it broke instead of extending.

It was found that the rate of stretching and degree of elongation were both material-dependent properties. While polystyrene and polycarbonate could be stretched 300 to 400 percent with proper control of stretch rate and temperature, MIL-P-8184 acrylic plastic could not be stretched more than 125 to 150 percent or at a rate greater than 1.0 inch per minute without breaking.

Cooling and heating equilibrium curves were determined by drilling appropriate wells in one-inch-thick plastic samples, inserting thermocouples and manually recording heating and cooling curves. It was found that about 90 minutes would be required to reach equilibrium throughout a one-inch thickness.

The results of these heating and cooling experiments showed that heat transfer rates would limit the rate at which thick plastic sheets could be brought to temperature equilibrium or quenched to room temperature during stretching experiments. Quenching rate is therefore effectively independent of experimental conditions in the work carried out on this project.

It was also found during the initial investigation that temperature gradients existed in the thermostatic cabinet which caused uneven stressing and elongation of plastic specimens. This temperature gradient problem was overcome by inserting and adjusting baffles in the cabinet.

The birefringence patterns in the transparent samples were observed with the reflection polariscope during the stretching process. Stress concentrations were found near the grips, but with polystyrene and MIL-P-8184 acrylic, only 3 to 4 sets of fringes could be observed during the initial part of stretching experiments. Because of the inhomogeneity developed in uniaxially stretched material, the decrease of intensity as fringes increased in number soon led to patterns too weak to detect by the reflection method. In the case of polycarbonate, the pattern consisted of many narrow fringes initially and stressing immediately caused this pattern to become too weak to detect.

Residual stresses in stretched samples after cooling could be observed by use of a 12- by 16-inch window transmission polariscope.

It was concluded from these experiments that a transmission system of high light intensity would be needed to observe birefringence phenomena during uniaxial stretching trials. As would have been predicted from theory, uniaxial stretching led to stress concentrations at grip holes and along the edges of samples where necking occurred.

#### d. Samples Prepared

The following samples were prepared for crack propagation tests:

##### (1) Polystyrene

One-quarter-inch-thick sheet was stretched at 105, 115, and 125°C. Rates of stretch tried were 1, 10, and 20 inches per

minute. Samples were elongated 75, 150, and 300 percent. They were cooled by opening the thermostat door with the circulating fan on, which reduced sample temperature at a rate of about 24°C per minute.

(2) MIL-P-8184 Acrylic

One-quarter-inch and one-inch-thick sheet was stretched at 130, 140, and 150°C. Rates of stretch tested were 0.5 and 1.0 inch per minute. Samples were elongated 75, 100, and 125 percent. Breaking of samples was experienced at 125 to 150 percent elongation and a load of about 1200 pounds for the one-inch-thick stock. The cooling rate used was the same as for polystyrene, that is, 24°C per minute.

(3) Polycarbonate

One-quarter-inch and one-inch-thick sheet was stretched at 160, 170, and 180°C. Rates of stretch tested varied from less than 0.2 to 1 inch per minute. Samples were elongated 75, 150, 225, 275, and 375 percent. Maximum elongation was achieved by stretching at minimum speed. At higher rates the sample would neck considerably and eventually break. The cooling rate used was the same as for the other two materials tried.

Preliminary results on uniaxially stretched polycarbonate led to a request by the U. S. Army Natick Laboratories for preparation of additional samples. A substantial amount of uniaxially stretched one-half-inch and one-inch-thick sheet was therefore processed. Twenty runs were made for this purpose and about 10 square feet of uniaxially oriented polycarbonate was submitted to NLABS.

e. Results of Tests on Uniaxially Stretched Plastics

It had been planned originally that only crack propagation and visual observation tests would be made on uniaxial trial products. For reasons explained below in greater detail, other testing proved desirable.

The crack propagation test procedure used was that of Military Specification MIL-P-25690A. Except as noted specifically, the sample dimensions were 1.75 ± 0.01 inches wide by 6.00 ± 0.01 inches long by the material thickness.

The problem of initiating cracks across the orientation of uniaxially stretched sheets makes this test impossible. At the request of NLABS, tensile and modulus of elasticity tests were substituted.



The uniaxial tests reported, therefore, are values obtained from samples with a drilled central hole and jeweler's saw cuts but not initiated cracks. Also, to obtain test data quickly, the outer ends of the samples were necked down to one-inch width to fit the available Tinius Olsen Test Machine jaws. Two-inch jaws were procured and used in all subsequent test work.

Sketches at full scale showing several sample thicknesses and indicating how they were necked are included with this report and discussed under the individual materials.

#### (1) Polystyrene

The one-quarter-inch-thick polystyrene purchased for this project was found to give a very uneven cockled surface when hot-stretched. Tests on one-inch-thick polystyrene, however, gave smooth, clear, transparent surfaces. Other sources of material might provide a more satisfactory one-quarter-inch sheet. Efforts to anneal or press the sheet on hand were unsuccessful with respect to improving its clarity after stretching.

The birefringence of the samples was examined during stretching and after cooling. As might be suspected from the cockled surface, stress and orientation gradients existed in the test specimens. Development of large areas of uniform structure was not found. During the stretching, only three spectral bands could be picked up by the reflection polariscope. Examination of cooled samples in a transmission polariscope showed many bands of spectra along and across the stretched plastic sheet.

Attempts to prepare crack propagation test samples from uniaxially stretched polystyrene were unsuccessful. Although cracks could be initiated along the direction of stretching, as called for in MIL-P-25690A, attempts to initiate transverse cracks either led to breakage of the knife used to start the crack, or when a crack was started, it turned at 90° and followed along the stretching direction. These phenomena are interpreted as indicating reinforcement by hot-stretching as predicted on theoretical grounds.

Data for tensile strength, modulus of elasticity and toughness factor determined as mentioned above were obtained. The results and the conditions of stretching are reported in Table II. The test procedures used were ASTM D638 for tensile and modulus and MIL-P-25690A for crack propagation.

Thickness distributions in the crack propagation samples and the cuts made to fit the Tinius Olsen test machine jaws available at the time of testing are shown in Figure 2.

Table II

## PHYSICAL PROPERTIES OF UNIAXIALLY STRETCHED POLYSTYRENE

°C Temp- erature	Elonga- tion inches	Rate of Elonga- tion in./min.	Sample Number	Ultimate Tensile Strength psi	Modulus of Elasticity		Crack Propagation Load at Break pounds	
					10 <sup>5</sup> psi	psi		
105	3	1	12C	7,890,	6,739,	7,818	4.9, 5.4, 5.6	--
		10	11C	7,680,	7,297,	8,294	4.5, 4.6, 5.0	--
	6	20	10C	8,270,	7,360,	7,304	4.6, 4.8, 4.9	--
		1	3C	9,705,	9,850,	9,600	5.0, 5.1, 5.3	--
		10	4C	--	--	--	--	816
	12	20	5C	9,851,	9,672,	9,870	4.6, 4.9, 4.8	--
			8C	10,526,	11,076,	11,020	4.6, 4.8, 4.6	--
10		6C	10,526,	11,127,	11,294	4.5, 4.9, 4.7	--	
20		7C	7,555,	11,094,	11,250	4.8, 5.1, 5.0	--	
115	3	1	21C	--	6,050,	6,379	--	--
		10	22C	6,518,	6,977,	6,240	--	--
	6	20	23C	6,889,	6,279,	5,922	--	--
		1	16C	7,343,	7,935,	7,862	4.6, 4.7, 4.9	--
		10	17C	--	--	--	--	615
	12	20	20C	8,542,	9,355,	9,283	4.8, 5.2, 5.0	--
			13C	9,600,	9,000,	10,000	5.1, 5.2, --	--
10		14C	11,020,	10,750,	10,909	4.1, 4.4, 4.2	--	
20		15C	11,000,	10,560,	9,795	4.4, 4.8, 4.5	--	
125	1	28C	7,130,	10,095,	9,966	4.9, 5.1, 5.1	--	
		29C	--	--	--	4.8, 4.9, 4.8	--	
	6	30C	3,428,	5,493,	7,130	--	--	
		26C	6,621,	7,384,	4,727	5.0, 5.3, 5.1	--	
		27C	--	--	--	--	Broke in jaws	
12	20	18C	6,476,	7,161,	7,200	4.6, 4.5, 4.8	--	
	1	19C	--	8,000,	7,024	--	--	
10	25C	8,470,	8,400,	8,000	--	--		
Unstretched Controls				4,698,	3,795	4.7, 5.0		
				3,237,	3,128	5.0, 4.8		

All tests made with sample pulled along direction of stretch.

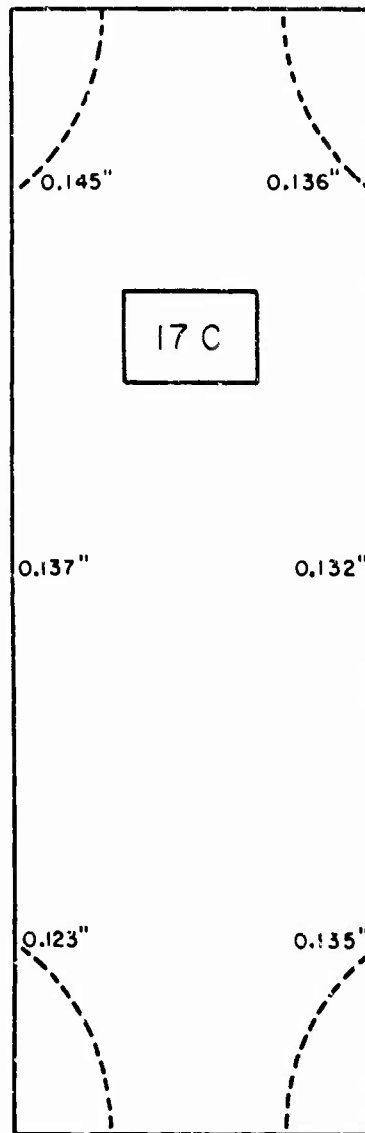
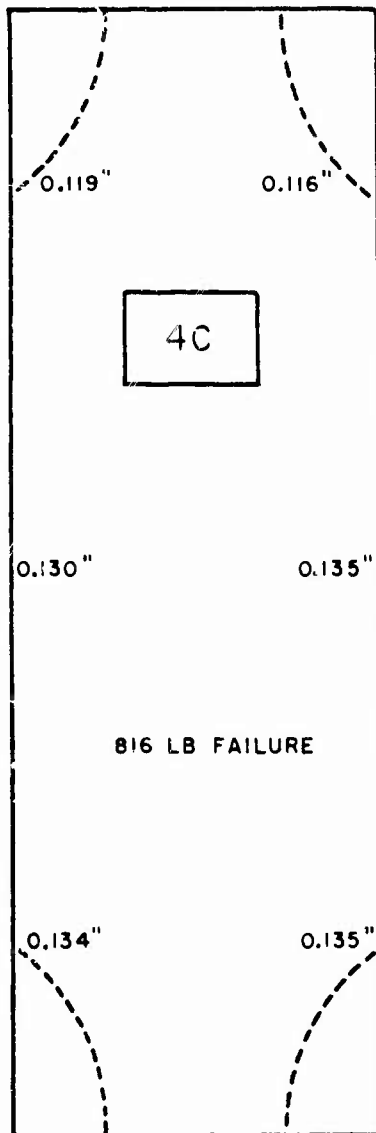

POLYSTYRENE

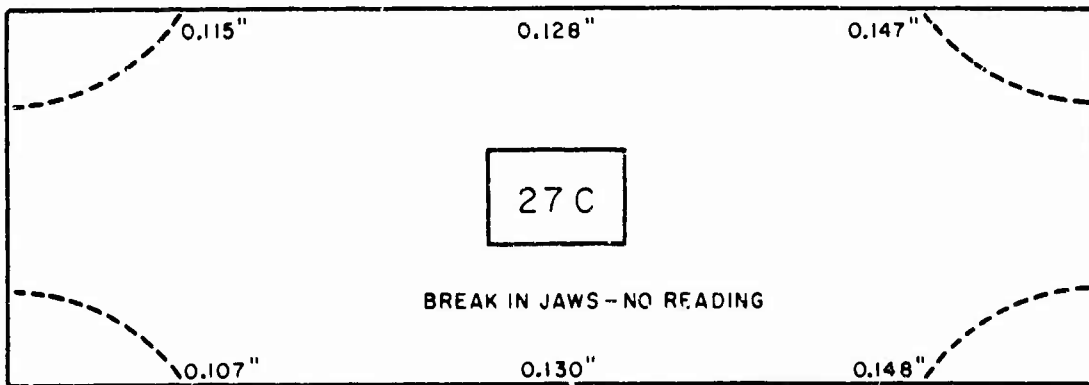

DISTRIBUTION OF THICKNESSES ON THE CRACK PROPAGATION SAMPLES

FIGURE 2

## (2) MIL-P-8184 Acrylic

Modified Acrylic sheet one-quarter-inch thick meeting specifications of MIL-P-8184 was prepared as six- by six-inch squares and stretched uniaxially. Data for tensile strength, modulus of elasticity and toughness factor were determined. The results of physical tests and the conditions of stretching are reported in Table III. The test procedures cited for polystyrene were used.

The one-quarter-inch-thick acrylic plastic was found to give clear transparent samples after stretching, although occasional striations were observed. Two tensile bars and one crack propagation specimen per trial were prepared.

Again it was found that cracks could not be led across the direction of stretching. Tests made used a central hole with transverse jeweler's saw cuts as defect. As in the case of the polystyrene samples, thicknesses of the acrylic pieces are shown in Figure 3.

The birefringence of the acrylic samples was found to be much more uniform than that observed with polystyrene. Wide bands and areas of uniform color can be seen between crossed Polaroid plates. The uniformity may be associated with the use of a casting process to fabricate acrylic sheet while polystyrene sheet is prepared by extrusion.

As a check on procedures, a one-half-inch-thick, biaxially-oriented, commercial acrylic sheet was obtained through the U. S. Army Natick Laboratories. This commercial product showed no color between crossed Polaroid plates until it was tilted at an angle. Under these conditions a uniform color showed. Presumably biaxial orientation gives cancellation of birefringence in a sample viewed normal to the plane of stretching.

## (3) Polycarbonate

One-quarter, one-half and one-inch-thick polycarbonate plastic sheets were stretched without difficulty. The optical quality of the stretched product seems to be comparable to the MIL-P-8184 acrylic. Physical test results for polycarbonate sheets are shown in Table IV. Contrary to initial assumptions, these tests show that the polycarbonate tensile strength is about equal along and across the direction of stretch.

It was found when attempts were made to propagate cracks in uniaxially stretched polycarbonate that the material was unusually tough. Neither transverse nor longitudinal cracks could be propagated. In either direction the blade of the cracking tool pushed into the plastic without causing a crack to form.

Table III

## PHYSICAL PROPERTIES OF UNIAXIALLY STRETCHED ACRYLIC

°C Temp- erature	Elonga- tion inches	Rate of Elonga- tion in/min.	Sample Number	Ultimate Tensile Strength psi	Modulus of Elasticity 10 <sup>5</sup> psi	Crack Propagation "K", lbs./in. <sup>3/2</sup>
130	3	0.5	26B	13,770, 13,710	4.57, --	2985
	4	1.0	6B	13,420, 13,280	4.78, 5.19	3431*
		0.5	18B	15,370, 14,620	3.75, 5.35	3503
	5	1.0	25B	--	--	(1100**)
		0.5	13B	14,010, 13,970	4.41, 4.29	*
	6	1.0	4B	14,820, 15,000	5.19, 5.19	3170*
140	3	0.5	20B	13,230, 13,230	4.51, 4.66	3319
	4	1.0	23B	13,000, 13,330	4.13, 4.72	2372
		0.5	19B	13,350, 13,330	4.23, 4.33	3465*
	5	1.0	21B	--	--	(1695**)
		0.5	27B	14,520, 14,320	4.97, 4.35	3209
	6	1.0	1B2	14,610, 14,530	4.97, 4.83	2850*
150	3	0.5	29B	13,240, 13,090	5.19, 5.19	3044
	4	1.0	34B	14,090, 13,800	4.69, 5.33	3699*
		0.5	28B	13,580, 13,590	4.76, 4.44	3522*
	5	1.0	32B	--	--	(2040**)
		0.5	31B	14,000, 14,000	4.76, 5.55	2945
	6	1.0	33B	14,630, 13,810	5.20, 5.48	4853*
Unstretched Controls				12,900, 12,200, 12,300	4.98, 4.49, 4.49, 4.40	1100 (668**)
				11,600, 12,000, 12,000, 12,900	4.49, 4.49, 4.49, 4.94	1128 (690**)
				12,000, 11,000, 12,300, 11,500	5.28, 5.80, 5.44	
				11,900	5.20, 5.26	

\* Imperfect crack

\*\* Pounds load at break, "K" not calculated

All tests made with sample pulled along direction of stretch.

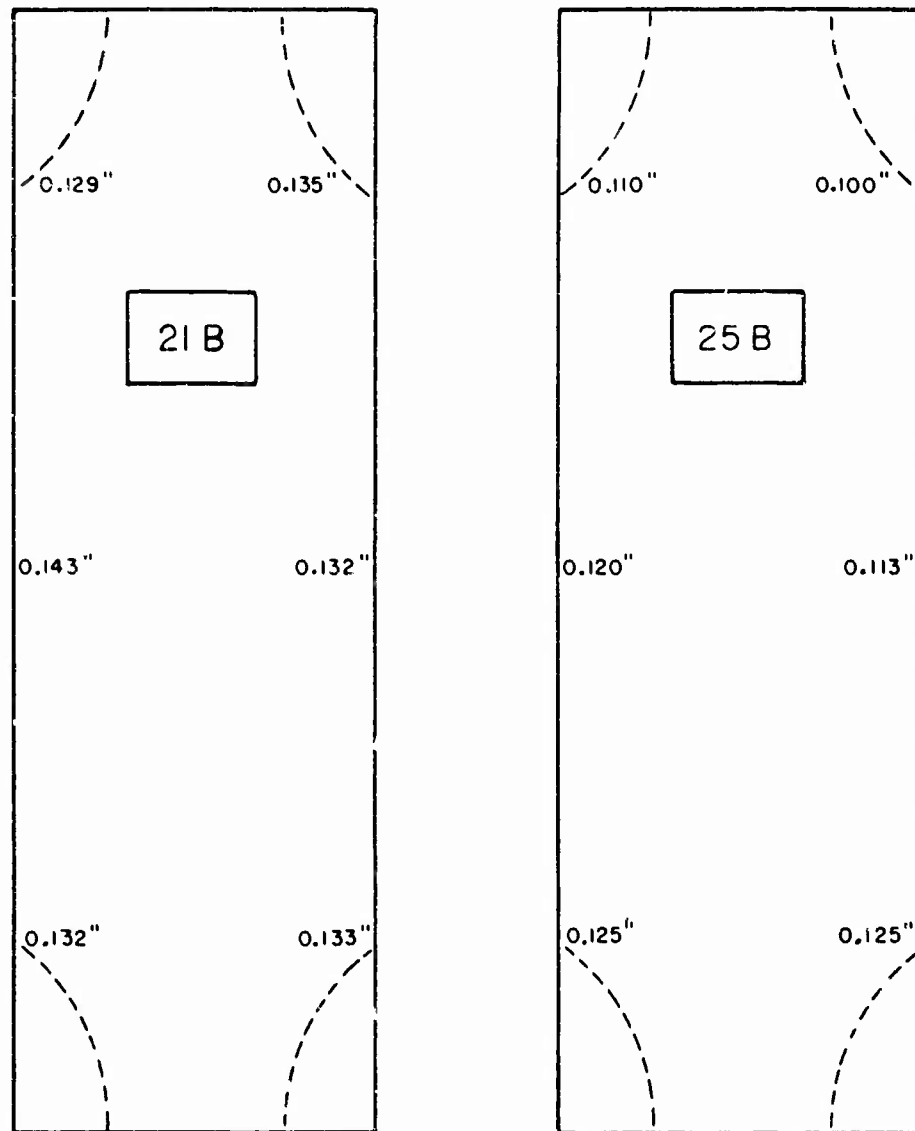

MODIFIED ACRYLIC

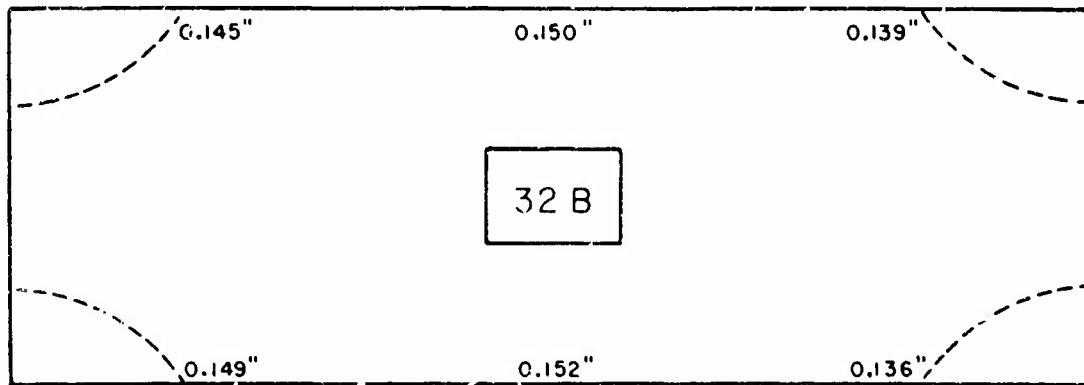

DISTRIBUTION OF THICKNESSES ON THE CRACK PROPAGATION SAMPLES

FIGURE 3

Table IV

## PHYSICAL PROPERTIES OF UNIAXIALLY HOT-STRETCHED POLYCARBONATE

°C Temp- erature	Elonga- tion percent	Rate of Elonga- tion in./min.	Sample Number	Ultimate Tensile Strength psi	Modulus of Elasticity 10 <sup>5</sup> psi	Crack Propagation Load at Break pounds
175	50	1	40 along stretch	7990, 9930 7380, 9700 10000, Avg9000	3.91, 3.83 2.98, 3.13 3.46, Avg3.46	
			40 across stretch	9260, 9630 9520, 9540 9750, 10850 9680, Avg9754	2.60, 2.78 2.59, 3.25 3.24, 2.64 3.27, Avg3.40	
175	50	1	38 along stretch	10000, 9840 10350, 10280 Avg10117	3.62, 3.64 3.81, 3.03 Avg3.02	
			38 across stretch	9980, 9530 9480, Avg9330	3.13, 3.09 3.54, Avg3.25	
Unstretched Controls						
160	100	1	5A	9065, 9267 8667, 9209 9000, Avg9042	3.37, 3.33 3.52, 3.66 3.73, Avg3.52	1975
170	100	1	6A			1500
180	100	1	4A			1610

All tests made with sample pulled along direction of stretch.

For comparative purposes, the load at break of crack propagation samples was determined in the manner used for polystyrene and polymethyl methacrylate and the values obtained are shown in Table IV. Test procedures ASTM D638 and MIL-P-25690A were again applied. The distribution of thicknesses in the crack propagation samples is shown in Figure 4.

The birefringence of the polycarbonate showed steep gradients in stress or orientation. In fact, the color bands were so narrow and numerous that observation during stretching was not possible with the light available.

#### f. Uniaxial Screening Trials

The equipment and procedures covered in Section 3e were used for uniaxial screening tests on a series of plastics which were being considered for later ballistic test panel preparation.

The samples obtained for screening were:

Polypropylene, 1/4-inch thick

Nylon, 1/4-inch thick (Nylon 6)

Delrin, 1/16- and 1/4-inch thick (acetal homopolymer)

Celcon, 1/8-inch thick (acetal copolymer)

Polyphenylene oxide, 3/8-inch thick

Polysulfone, 1/2-inch thick.

Uniaxial stretching trials made on the polypropylene, nylon, Delrin and Celcon are summarized below. The polyphenylene oxide and polysulfone samples were held for later screening by biaxial instead of uniaxial stretching.

##### (1) Polypropylene

Four polypropylene pieces one-quarter-inch thick and six inches by six inches square were stretched under varying conditions. The samples started to neck and stretching then propagated throughout the whole sample. Conditions used and results were:



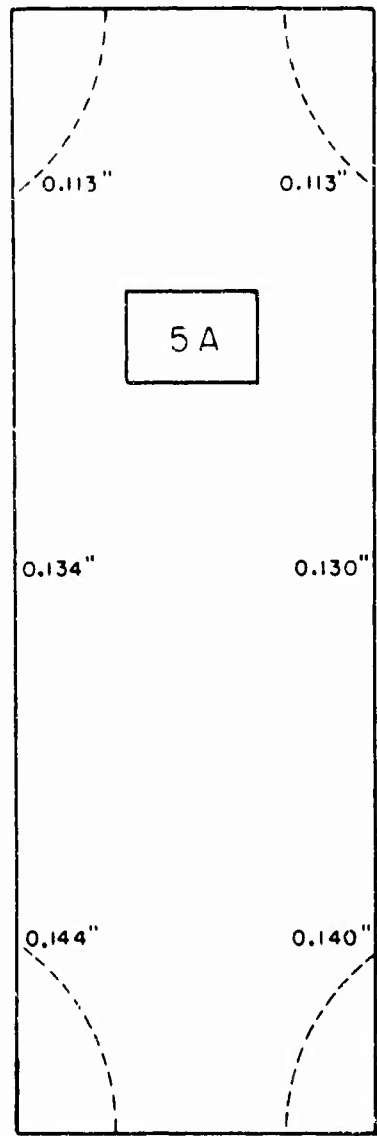
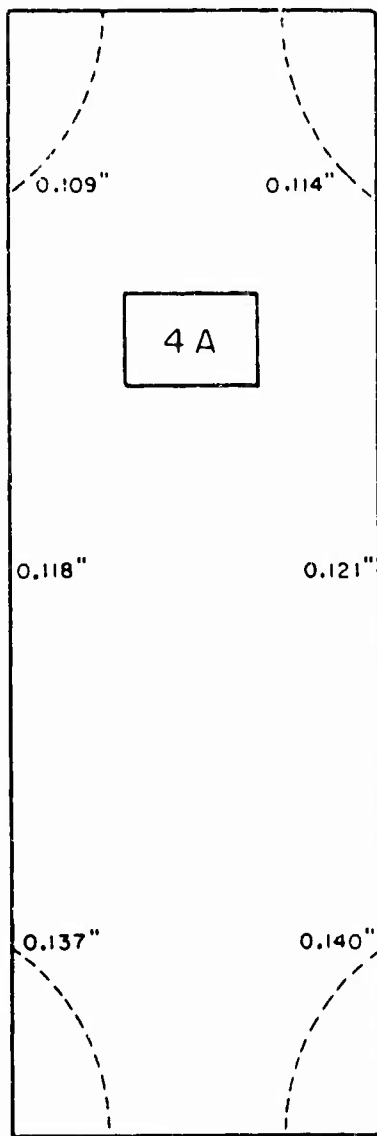

POLYCARBONATE

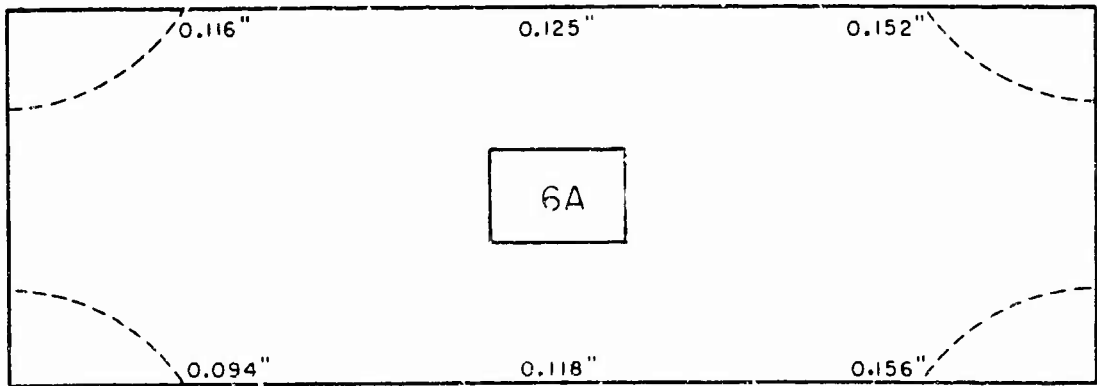

DISTRIBUTION OF THICKNESSES ON THE CRACK PROPAGATION SAMPLES

FIGURE 4

<u>Stretching Rate</u> <u>in./min.</u>	<u>Cooling Rate</u> <u>°C/min.</u>	<u>Stretching</u> <u>Temperature</u> <u>°C</u>	<u>Remarks</u>
0.5	--	130	Tore at pins
0.5	24	140	Stretched at holes
0.5	24	145	Became transparent
1	24	140	Became clear as above
10	24	140	Tore and broke at pins

No physical tests were made on these samples because of their nonuniformity and thickness gradient, even though this material was listed as standard polypropylene sheet.

(2) Nylon 6

Four pieces of nylon one-quarter-inch thick and six by six inches square were stretched at 180°C. It was found that the samples had to be stretched very slowly, about 0.1 inch per minute, until necking took place. Then they could be drawn at speeds up to two inches per minute.

At the temperature used, heat degradation was occurring; therefore, the samples were drawn as quickly as possible. It was found that much of the degradation of the surfaces could be eliminated by spraying with a silicone mold release agent. The samples were cooled at a rate of about 24°C per minute.

Physical test results are shown in Table V.

(3) Delrin

Three pieces of 1/16-inch (0.065") thick Delrin were stretched. At 170°C the sample broke at the pull pins. At 180°C the sample stretched with a very rough texture and split along the stretching direction. The sample had no tensile strength at 190°C, being almost molten.

In the two lower temperature trials, the rate of stretching was kept below the breaking load limit until the sample necked down and the load decreased. Samples could then be stretched as fast as two inches per minute. Samples were cooled after stretching at about 24°C per minute.

Table V

PHYSICAL PROPERTIES OF UNIAXIALLY STRETCHED NYLON 6

Tensile Strength, psi	Modulus of Elasticity, psi ( $\times 10^5$ )	
	<u>Unstretched</u>	<u>Stretched</u>
11,371	24,162	3.50
11,233	26,356	3.50
	25,714	6.57
	25,400	6.85

The source of this material was stock on hand at the Research Foundation. Exact origin is unknown but the sheet was determined to be Nylon 6.

All tests made with sample pulled along direction of stretch.

Three pieces of one-quarter-inch-thick Delrin were also stretched. At 170°C the sample again broke at the pins. By going to 175°C the sample stretched fairly well and gave a uniform satin texture. At 180°C the sample gave a very rough texture and tore in the middle while being stretched.

The rates of extension and cooling were controlled for the one-quarter-inch-thick Delrin in the same manner as for the 0.065 inch sheet. The specimens produced were unsuitable for any physical tests.

(4) Celcon

Four samples of Celcon plastic sheet one-eighth-inch thick were stretched.

At 135°C and one inch per minute extension, the sample broke at the pins. At the same extension rate and 140°C, the sample stretched well but tore longitudinally. Stretching at 145°C gave good extension and the sample changed from a white, opaque to a clear plastic. At 155°C the stretching also proceeded well but the sample did not become as clear as at 145°C. No physical tests were performed.

g. Physical Test Check Results on Commercial Biaxially Oriented MIL-P-8184 Acrylic

As a check on the procedures, techniques and results of this work, NLABS furnished pieces of commercial biaxially oriented MIL-P-8184 acrylic for testing. Tensile strength, modulus of elasticity and toughness factor values are shown in Table VI. The "K" values obtained in the tests were about three times those normally obtained for biaxially oriented acrylic sheet. An inspection of the original data showed that the technician who performed the crack propagation test made an error either in recording or measuring crack length.

A group of three sets of crack propagation test samples was therefore obtained from a supplier. The first set had been tested by the supplier who measured the "K" value as 3266 lbs./in.<sup>3/2</sup>. The second set was submitted with cracks initiated by the supplier. The average "K" obtained on these samples was 2661 lbs./in.<sup>3/2</sup>. The third set was supplied ready for crack initiation but the cracks were started in the laboratory. The average "K" obtained was 2593 lbs./in.<sup>3/2</sup>. It is believed this value is an excellent check of the 2661 lbs./in.<sup>3/2</sup> but both values are significantly lower than the 3266 lbs./in.<sup>3/2</sup> submitted by the supplier.

It is concluded that "K" values obtained in the tests will be about 20 percent below values of commercial laboratories because of some unknown factor in the technique of performing this test.

Table VI

PHYSICAL PROPERTIES OF BIAXIALLY ORIENTED  
ACRYLIC SHEET SUPPLIED BY U. S. ARMY  
NATICK LABORATORIES

Ultimate Tensile Strength psi	Modulus of Elasticity $10^5$ psi	Toughness Factor* lbs./in. <sup>3/2</sup>
12,919	4.88	9235
11,610	4.59	8487
12,281	4.69	6777
12,469	5.36	8406
12,190	4.76	--
12,189	4.72	6784

\* Original notebook shows error in recording or measuring crack lengths.

CRACK PROPAGATION TESTS ON SAMPLES  
FROM A COMMERCIAL SUPPLIER

Sample Identity SI 48732, Supplier's K = 3266 lbs./in.<sup>3/2</sup>

Toughness Factor Results (lbs./in.<sup>3/2</sup>)

<u>Crack initiated by supplier</u>	<u>Crack initiated by LTIRF</u>
3025	2636
2600	2579
2376	3117
<u>2644</u>	<u>2040</u>
2661 Avg	2593 Avg

#### 4. Biaxial Hot-Stretching Equipment

The original work plan for this project included the use of a Universal Testing Machine as the motive power for stretching 12- by 12-inch plastic samples bidirectionally. It was proposed to build an attachment to the machine to provide equal rates of stretching in both directions simultaneously.

It appeared after preliminary work had been done on the uniaxial stretching of virtually all of the plastics for the program that the force required to stretch a 6- by 6- by 1-inch slab would be only on the order of magnitude of 40 pounds, even at the lower temperatures used. Consequently, a revision of the test program was made and a simplified machine designed. The design objectives were to provide ranges of temperature, stretching rate, draw ratio and cooling which would be applicable to as many transparent plastics as possible.

##### a. Equipment Design

The basic elements of the hot-stretching equipment which has been designed are shown in Figures 5 through 8. A photographic view of the skeleton of the unit is shown in Figure 5. Figure 6 is a side view of the frame of the stretching equipment with dimensions indicating its size. The means of holding and stretching plastic specimens by winding of wire cables on three-inch-diameter drums are shown in Figure 7. The gas-fired, forced-circulation heating system is shown schematically in Figure 8, which also shows a side view of the sample with water-cooled pin grips attached.

The new machine employs a two-way stretch mechanism enclosed in a transparent housing. The temperature surrounding the plastic sample can be varied from room temperature to approximately 200°C.

Because it is necessary to provide an optically clear view of the sample during the stretching to allow the use of a polariscope to observe birefringence, a relatively simple heating system has been devised. This consists of two 30- by 30-inch heat-resistant plate glass side plates. These plates are separated by about six inches, the space between the plates holding the sample. Around the perimeter of the glass sandwich are slotted cover plates to restrain the heated air provided to warm the sample.

##### (1) Heating System

Heating of the stretching equipment is by direct gas firing, the gas being burned in three standard household burners housed in a transite box approximately 12 inches wide by 24 inches long by 14 inches high. The burner is provided with dampers on

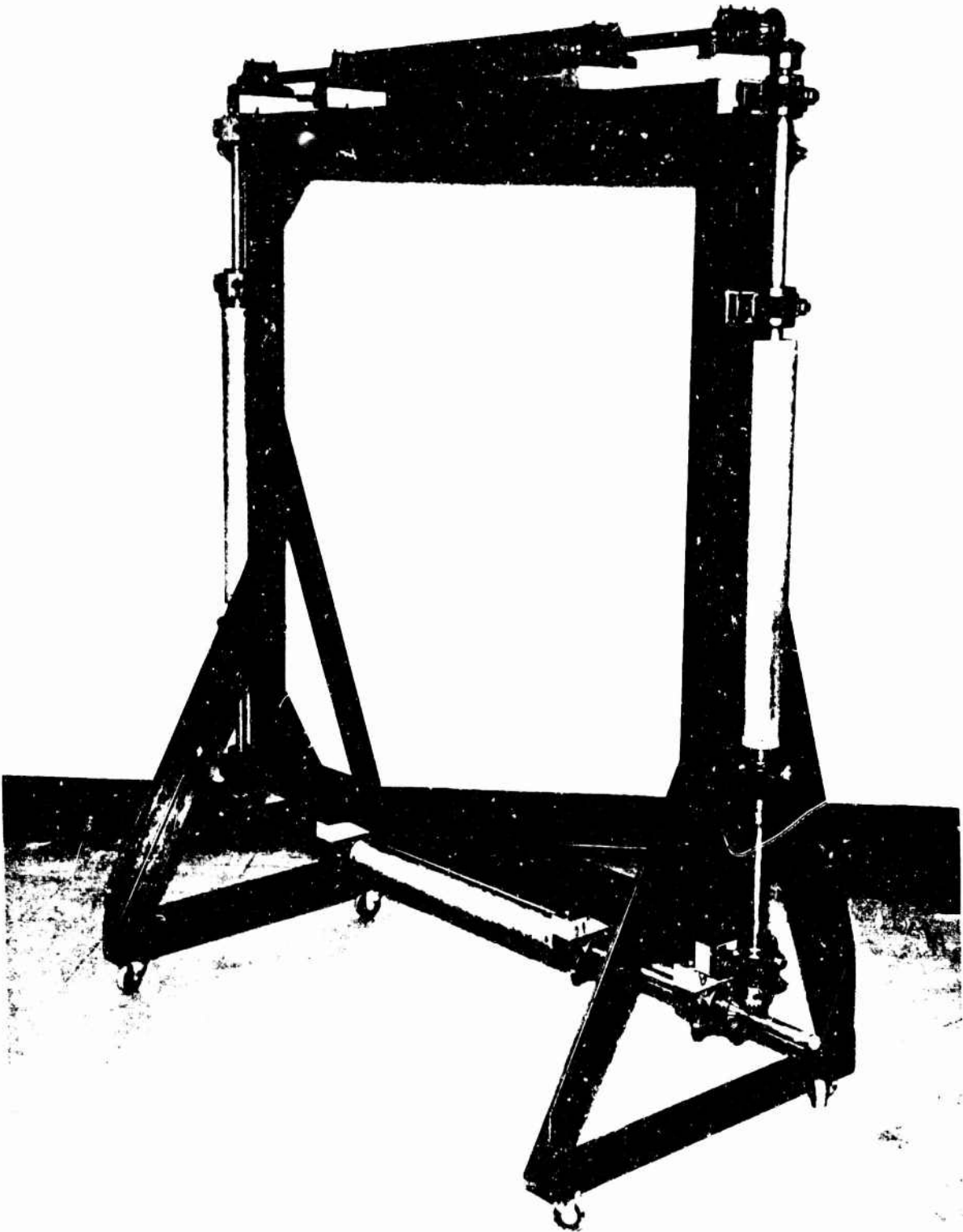

BIAXIAL HOT-STRETCHING EQUIPMENT

FIGURE 5

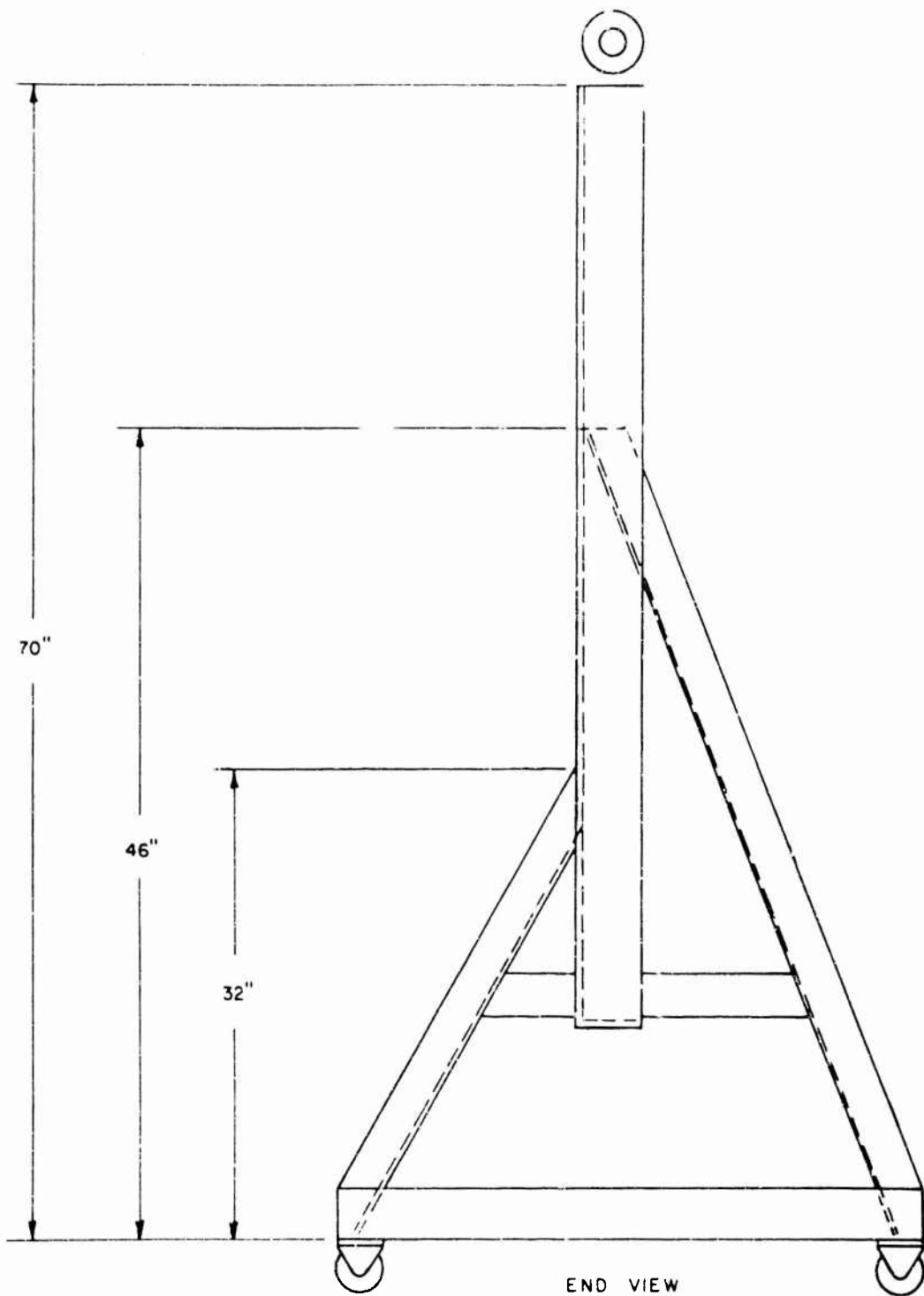

FRAME FOR PLASTIC STRETCHING DEVICE

FIGURE 6



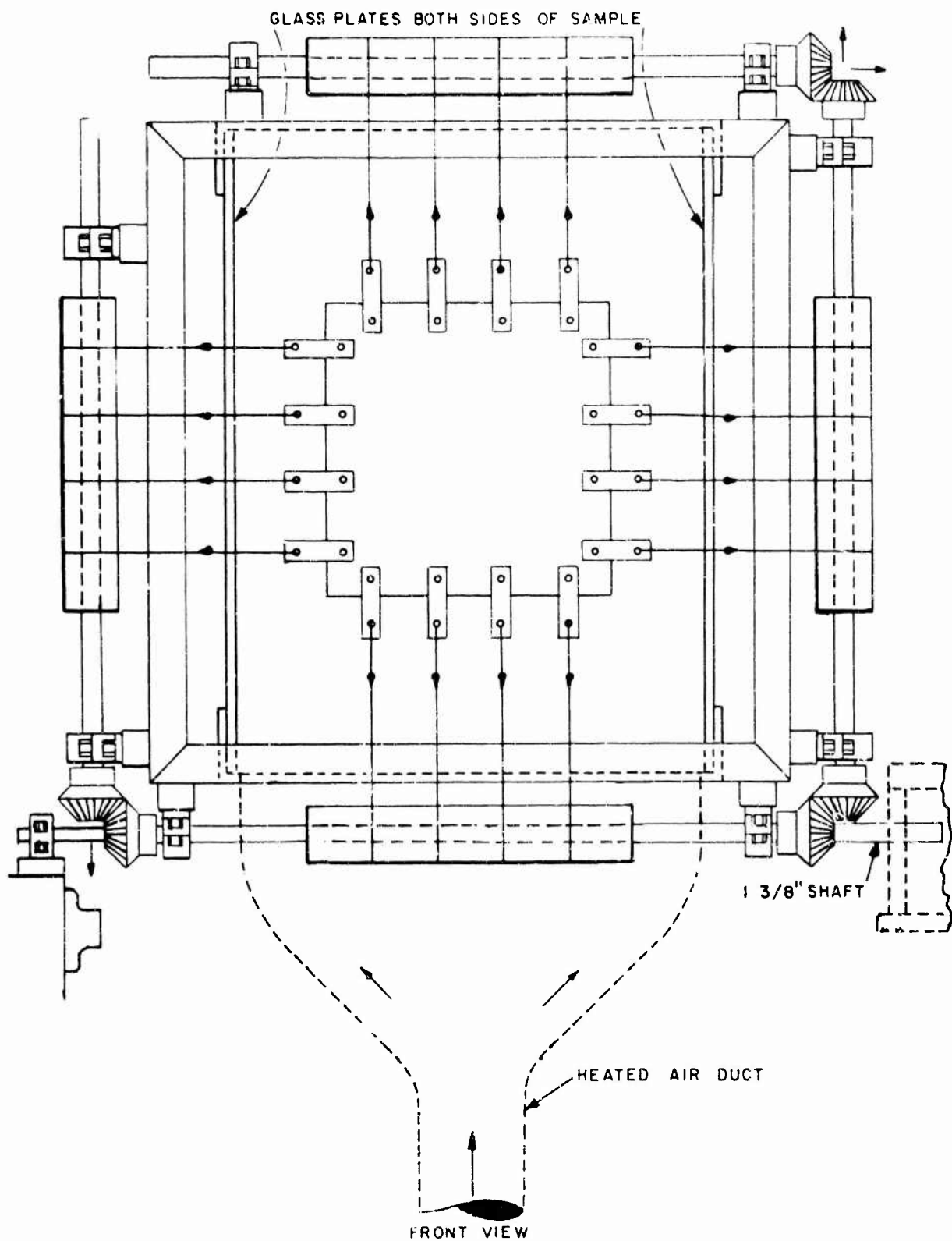

PLASTIC STRETCHING DEVICE

FIGURE 7

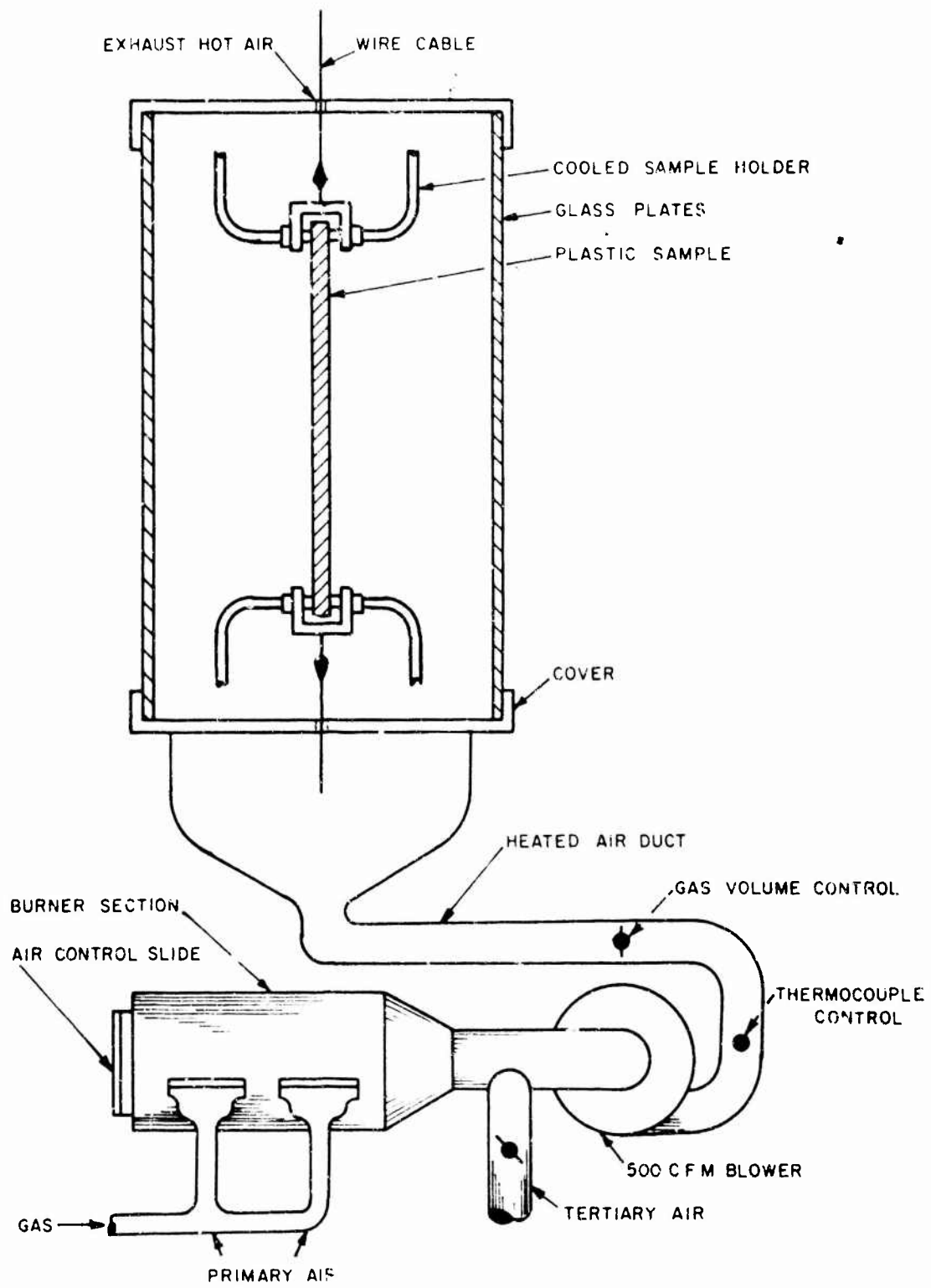

HEATING SYSTEM FOR PLASTIC STRETCHING DEVICE

FIGURE 8

both the inlet and outlet for air velocity control, as well as primary and secondary air vents and an observation hole to observe the character of the gas flame. Velocity is provided by a constant speed fan with a top capacity of about 500 cfm. The discharge of the oven, as shown in Figure 7, is through an enlarged opening approximately 4 inches by 14 inches directly into the stretching chamber.

Inside the stretching chamber are a number of air deflectors to spread the hot gases to both sides of the sample. Experience has shown that five adjustable baffles are necessary to control the gas flows and temperatures within necessary limits. Thermostatic controls are provided to modulate the air at any given level. Temperature regulation is within  $\pm 2^{\circ}\text{C}$  over the total sample surface. Heating can be continued during the stretching of the sample without interference.

One of the glass plates is hinged to allow easy access to the sample and provision is also made to provide cooling of the sample after stretching.

To speed up the heating, a bank of infrared heaters was used for some of the stretching and this reduced time for warm-up by about an hour.

## (2) Housing

Considerable work was done to provide a relatively gas-tight enclosure for the sample by means of sheet metal housing on all four sides of the enclosure, as shown in Figure 9. Holes were provided where necessary for the stretching wires and for the thermocouple connections. Provision was also made for traversing thermocouples to determine the temperature profiles at various points in the enclosure and at the face of the sample.

## (3) Stretching Rate Control

This device provides not only the requisite temperature range and control but more than adequate control of the rate of stretching.

The main drive was provided by a 1/4-hp variable speed drive with a 10:1 speed regulation, through a 600:1 speed reducer, and direct-connected with the bottom shaft, as shown in Figure 9. The drive is reversible to allow for relaxing of the sample during the cooling process, if this is necessary.

Rates of stretching can be varied from about 0.2 inch per minute to 1.7 inches per minute or more, a 10-fold variation in rate of elongation.

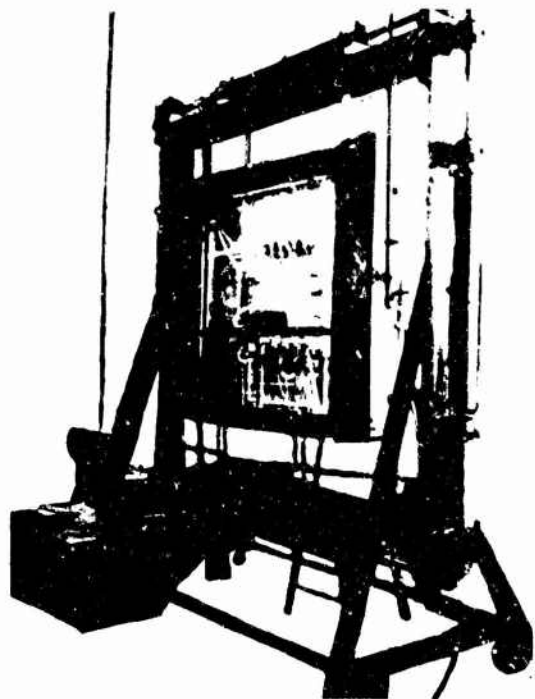

(a) GENERAL VIEW.

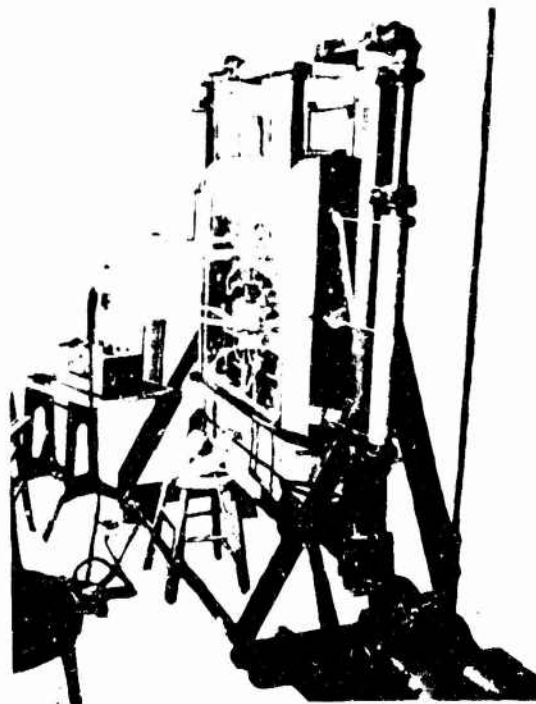

(b) VIEW SHOWING AUXILIARY INFRARED HEATER AND THERMOCOUPLES.

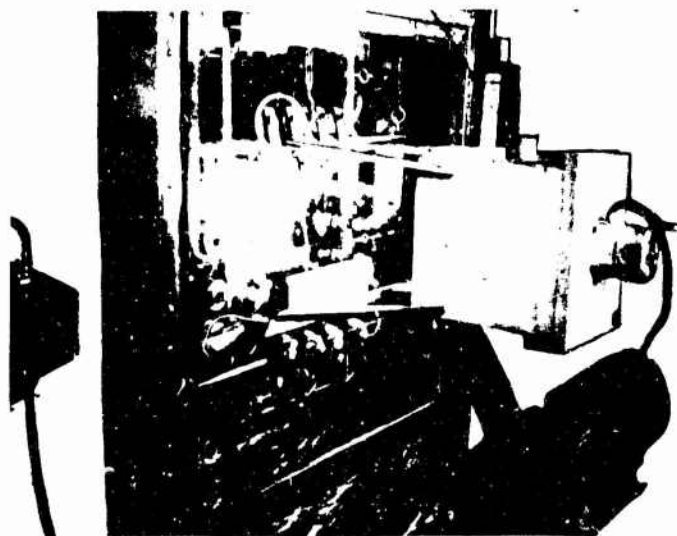

(c) CLOSE-UP SHOWING INFRARED HEATING OF CENTER OF SHEET TO BE STRETCHED.

HOT-STRETCHING UNIT

FIGURE 9

#### (4) Sample Clamping

The clamping mechanism developed through work on uni-directional stretching consists of a series of U-shaped arms with a metal tube through the arm and through the sample. This metal tube is water-cooled so that there is no distortion on the plastic sample, yet the holder is free to move in a lateral direction, thus eliminating undue stresses which would occur with a fixed clamp. From the experiments done so far, this appears to be a major improvement in two-way stretch devices.

Further, the clamps are connected to the driving cylinder (as indicated in Figures 7 and 8) by steel wire cables which likewise are free to move, thereby providing a stress-free clamp.

#### (5) Birefringence Observation

As mentioned previously, experience with the reflection polariscope during uniaxial tests led to the conclusion that a high intensity extended source of polarized light used in the transmission mode would be required to study birefringence effects during biaxial stretching. An available polarizer with an illuminated area of about 18 by 24 inches was therefore set up behind the stretching unit. Transmitted light birefringence patterns in the samples were observed by using the analyzer disc of the reflection polariscope.

#### b. Equipment Modification

Early work with the biaxial stretching unit led to a number of modifications. These changes were associated mainly with problems of temperature control and stretching force.

##### (1) Temperature Control Improvements

It became apparent from the first stretched samples prepared that temperature controls are more stringent than at first anticipated. Temperature control within 1°C over the entire sample is necessary to give a stretched material which is completely uniform.

In order to provide this kind of control, a good deal more work was done on the distribution and temperature of the air. Problems also existed in the hot-stretching unit with regard to uniformity of stretching in the two axes and with cooling of the pins used to pull the sheet.

It was found that some of the temperature problems arose from the thermocouples being corroded during use. Initially, iron-constantan wire in Teflon covering was selected. In the hot

combustion product atmosphere resulting from direct firing with natural gas, attack by water vapor on the wire occurred. The iron-constantan thermocouples were replaced by glass fabric covered copper-constantan.

The water flow through the pins used to pull samples was also found to influence temperature uniformity. Parallel flow paths to each side of the sheet with individual flow control were provided to reduce this problem.

## (2) Mechanical Equipment Improvements

The results of biaxial stretching trials showed that initial information on stretching behavior obtained from uniaxial tests was not really applicable when the samples were pulled simultaneously in two directions. Cross section reductions between the pins through the samples were far less than the reductions obtained through necking when samples were pulled uniaxially. Also, it seems probable that stress orientation reinforced sheets as they were being stretched.

Numerous gear failures on the hot-stretching machine were experienced during trials. The cause of the failures was traced to deflection of the shafts at the primary bevel gear set driving the unit. Because of misalignment and excessive stresses produced on the gear teeth, the original cast iron bevel gears had to be replaced by steel bevel gears.

The main shaft to the motor was increased in diameter and made of a tougher type of steel. An additional bearing to restrain deflection on the bottom shaft at the outboard end was also installed. These changes led to satisfactory operation of the stretching unit.

Uniformity of stretching on the four sides of the sheet being pulled was improved by rearranging the position of the stretching cables, by carefully aligning the cable attachments on the drums by shifting the spacing of the gripping holes in the sheets being stretched, and by restricting the sideways travel of the clamping pins in the sheet in some stretching trials.

The side motion restriction was obtained by threading a chain around the sheet and attaching it to the cables at the clamps in such a way that the clamps could not separate by a distance greater than their theoretical limit for the degree of stretching planned.

With these adjustments, the uniformity of the stretched sheets was excellent and productivity of the equipment was improved greatly.

## 5. Biaxial Stretching Trials

During the course of this project, extensive improvements were realized in techniques of hot-stretching as well as in equipment for stretching. Most of these improvements resulted from determination of the nature of critical variables and development of means to control these variables.

By far the most important variable is material temperature. It is essential to have uniform temperature throughout the plastic sheet to be stretched. The attainment of uniformity requires preheating of material outside the stretching unit, allowing sufficient time for heat transfer to the center of the sheet. The cooling grips must also be carefully adjusted to uniform temperature through control of the water flow through them. Finally, the temperature at all points on the surface of the sheet must be the same. Thermocouples in the air and in the sheet at each corner of the piece being stretched were provided to get the uniformity needed.

Even pull in four directions was attained by empirical adjustment of the grips so that the four corners and the centers of the four sides of the plastic sheet move at about the same rate during stretching.

The thickness of the finished sheet varies somewhat from center to edges but the procedures developed have greatly reduced this variability.

The results for the individual materials investigated will be discussed in detail in subsequent parts of this section of the final report. As generality, it can be said that the hot-stretching behavior and crack propagation phenomenon in acrylic plastics seem to be unique. While the screening work on other plastics was necessarily cursory, it supported results of complete investigations of polystyrene, polycarbonate and MIL-P-818 acrylic plastic sheets in highlighting the unusual behavior of the acrylic materials. The polystyrene and polycarbonate sheets produced were less satisfactory in appearance. Physical test results did show evidence of property improvement by biaxial hot-stretching although no definite pattern of improved properties showed.

It had initially been expected that observations of birefringence could be made during the hot-stretching process and would serve as a guide to optimization of orientation in the sheet being stretched. It was found, however, that, except for small areas near the grips where thermal and stress gradients could persist, the stress throughout the sheet being pulled equalized and a uniform birefringence color was present. Observation of birefringence was therefore discontinued and no further remarks on this procedure are made.

It is concluded that the hot-stretching procedure used produces equalized biaxial stress by self-compensation for applied strains.

#### a. Plastics Evaluated Extensively

Three plastics were investigated in detail for effects of temperature, rate of stretch and percent of stretch. It was found that as a matter of practicality, these variables were limited by the objectives of producing substantial amounts of material for submittal to the U. S. Army Natick Laboratories and by the narrow ranges of conditions in which successful stretching could be done. The three materials, polystyrene, polycarbonate and MIL-P-8184 acrylic, are discussed below.

##### (1) Hot-Stretching of Polystyrene

The polystyrene evaluated in this work was general purpose material obtained in 1/4-, 1/2- and 1-inch sheet thicknesses. A small amount of 1-inch sheet from another source proved to be a heat-resistant type with a different rubbery range than the initial material. It was therefore not used.

When the 1/4- and 1/2-inch sheets were stretched, it was found that a cockled surface was produced. It is believed that this surface structure resulted from the extrusion process used to produce the sheets. Cockling was not experienced with the one-inch stock.

It was found that stretching could be produced in the temperature range from 105° to 125°C. Draw ratios up to 200 percent were attainable, but above 100 percent the center of the sheet being stretched thinned to such an extent that the piece produced was not useful for testing. Draw rates from about 0.4 to 4 inches per minute were tried. As noted previously, heating and quenching rates were controlled by the heat transfer characteristics of polystyrene.

##### (a) Physical Test Results for Polystyrene

As the initial material tried, extensive testing was done on polystyrene. Tensile Strength (ASTM D638), Modulus of Elasticity (ASTM D638), Izod Impact (ASTM D256), Horizontal and Vertical Shrinkage at Elevated Temperature (ASTM D794), Crack Propagation K Value (MIL-P-25690A) and Orientation Stress Release (ASTM D1504) data were determined. Considerable scatter in data was obtained. In many cases, the specimens were far from ideal because of nonuniformity of the stock from which they had to be taken.

With these limitations in mind, some trends are shown by the testing. The results of the tests are shown in Table VII. There seems to be an increase in tensile, modulus and impact strength produced by stretching. Temperature of stretch does not



Table VII

## PHYSICAL PROPERTIES OF BIAXIALLY HOT-STRETCHED POLYSTYRENE

Sample Number	Nominal Stretch Temperature °C	Percent Stretch	Original Thickness inches	Rate of Stretch in/min.	Tensile Strength psi	Modulus of Elasticity 10 <sup>5</sup> psi	Izod Impact ft.lbs./in.notch	Shrinkage Test & Vertical	Shrinkage Test & Horizontal	Crack Propagation K value	Orientation Release Stress lbs/in. <sup>2</sup>
101	105	50	1/4	4	6150	4.96	1.07			4090	74.5
					6740	7.59	1.36			4330	76.5
					6260	5.71	1.21			2730	Avg75.5
					6150	5.00	1.11			3400	
					Avg6325	Avg5.80	1.14		4100		
							Avg1.17		Avg3730		
102	105	50	1/4	4	6520	3.12	0.88	42.8	27.9	4250	62.3
					6720	3.26	0.93	39.8	36.6	4130	84.2
					6930	4.53	0.95	48.9	30.1	Avg4190	49.4
					7000	5.79	1.08	Avg43.8	Avg31.5		73.2
					6670	4.20	1.01				Avg67.2
					Avg6768	Avg4.18	0.76				
							Avg0.93				
8	105	100	1	1	4216	4.40					
					2734	3.85	0.35				
					2330	4.26					
					6842	8.28					
					Avg4030	Avg5.19					
74	115	100	1/2	4	6290	4.75	0.79	20.4	18.7	3230	50.3
					4990	5.55	0.65	37.4	23.7	4240	49.7
					6330	4.41	0.67	28.8	27.9	2520	50.5
					5800	6.73	0.55	28.1	34.3	1890	60.9
					Avg5352	Avg5.36	0.60	29.6	28.1	Avg2970	69.4
							0.73	Avg28.8	Avg26.5		Avg56.1
							Avg0.67				

Table VII (Cont'd)

## PHYSICAL PROPERTIES OF BIAXIALLY HOT-STRETCHED POLYSTYRENE

Sample Number	Nominal Stretch Temperature °C	Percent Stretch	Original Thickness inches	Rate of Stretch in/min.	Tensile Strength psi	Modulus of Elasticity 10 <sup>5</sup> psi	Izod Impact ft.lbs./in.notch	Shrinkage % Vertical	Shrinkage % Horizontal	Crack Propagation K value	Orientation Release Stress lbs/in. <sup>2</sup>
75	115	100	1/2	4	8490	6.38	0.69	14.1	37.5	3860	60.6
					7220	4.75	0.46	43.7	38.1	3240	64.8
					6890	4.99	0.65	40.7	29.5	4080	55.8
					7770	6.07	0.75	43.7	43.7	3860	77.8
					Avg 7293	Avg 5.27	Avg 0.64	Avg 36.9	Avg 36.6	Avg 3760	Avg 67.3
76	115	100	1/2	4	6800	5.09	0.81	29.6	28.8	4020	48.4
					5740	7.96	0.58	18.7	35.4	1815	57.3
					7160	5.56	0.68	31.2	28.4	4010	53.4
					Avg 6566	Avg 6.20	0.91	34.3	32.2	3620	77.8
						Avg 0.75	Avg 28.8	Avg 30.9	Avg 3882	56.1	
										47.9	Avg 56.8
12	115	100	1/2	1.5	3704	4.41					
					5169	4.33					
					4875	4.59	0.43				
					5594	4.15					
					Avg 4787	Avg 4.39					
21	115	50	1	0.5	4740	4.51		18.8	14.0	2130	
					5040	4.55		21.8	14.0	1980	
					4660	4.88		23.3	29.7		
					4110	3.87	0.11				
					Avg 4638	Avg 4.45	Avg 21.3	Avg 19.2	Avg 2055		

Table VII (Cont'd)

## PHYSICAL PROPERTIES OF BIAXIALLY HOT-STRETCHED POLYSTYRENE

Sample Number	Nominal Stretch Temperature °C	Percent Stretch	Original Thickness inches	Rate of Stretch in/min.	Tensile Strength psi	Modulus of Elasticity 10 <sup>5</sup> psi	Izod Impact ft.lbs./in.notch	Shrinkage Test % Vertical	Shrinkage Test % Horizontal	Crack Propagation K value	Orientation Release Stress lbs/in. <sup>2</sup>
22	115	50	1	0.5	5660 6250 5120 Avg5676	6.22 5.98 6.00 Avg6.06	0.15	21.9 10.9 21.9 Avg18.2	12.5 23.5 23.5 Avg20.1	2010 1865 2520 Avg2165	
3	115	50	1	1			0.33	26.6 23.6 34.3 29.7 12.6 17.2 Avg25.0	53.7 42.2 24.9 25.0 36.0 45.2 Avg37.8	4090	
10	115	100	1	0.6	5634 5548 5475 6023 Avg5672	4.15 4.60 4.21 4.73 Avg4.42	0.17	31.2 17.2 9.2 Avg19.2	11.0 31.3 25.0 Avg22.4	2910	
9	115	100	1	1	3562 2575 2012 2956 2900 2672 Avg2779	6.57 3.97 4.44 5.00 4.70 Avg4.94					

Table VII (Cont'd)

## PHYSICAL PROPERTIES OF BIAXIALLY HOT-STRETCHED POLYSTYRENE

Sample Number	Nominal Stretch Temperature °C	Percent Stretch	Original Thickness inches	Rate of Stretch in/min.	Tensile Strength psi	Modulus of Elasticity 10 <sup>5</sup> psi	Izod Impact ft.lbs./in.notch	Shrinkage % Vertical	Shrinkage % Horizontal	Crack Propagation K value	Orientalion Release Stress lbs/in.?
25	115	100	1	2.2	3480 6070 6870 5860 Avg5570	4.62 5.26 9.74 1.49 Avg5.27	0.21	42.7 35.4	21.9 21.9	3600 3799	
60	115	100	1	3.6				Avg39.0	Avg21.9	Avg3699	
										4850 6640 6200 6230 Avg6030	
11	125	100	1	1	4497 5063 4724 5024 Avg4827	3.76 4.41 3.93 5.45 Avg4.38	0.64	15.6 15.6 14.0	9.4 7.7 29.7		
58	125	100	1	4?				Avg15.0	Avg12.2		4050 2100 Avg3075

seem to be an important variable. In the case of polystyrene, there is an indication that K values are higher at higher draw speeds. This latter result is difficult to account for on theoretical grounds. There is no clear evidence in the case of polystyrene that draw ratio is an important variable.

It was found that crack propagation in biaxially stretched polystyrene was more difficult than in MIL-P-8184 acrylic sheet. The polystyrene seems to be more brittle so that the crack initiated may go all the way across the specimen or the specimen may break during test at points other than the point of initiation.

#### (b) Optical Test Results for Polystyrene

As required by the work plan for the hot-stretching project, optical tests were also performed on polystyrene after hot-stretching for comparison with hot-stretched MIL-P-8184 acrylic samples. The optical tests performed were deflection of line of sight, frequency of deflection pattern, haze and luminous transmittance by spectrophotometry. The optical properties of the hot-stretched polystyrene are given in Table VIII.

Image displacement was determined by ASTM D637-50. Data tabulated include the maximum observed deflection in inches of the image of a cross on a bull's-eye target and parameters defined in D637-50 as Displacement Factor, Frequency of Image Movement and Pattern Distance. Displacement factor is the maximum movement (in inches) of the image of the cross divided by the distance (in feet) from the projector to the screen, multiplied by 1000. Frequency of image movement is described as either irregular or wavy, frequent or single shift. Pattern distance is the maximum distance (in integer multiples of 5 inches) from the screen at which the specimen can be held without producing a sharply defined pattern of its minor surface irregularities.

The haze and transmittance measurements were made according to ASTM D1003-52, procedure B. A General Electric Recording Spectrophotometer with source Illuminant C was used.

#### (c) Materials Delivered

In accordance with contract requirements, two batches of hot-stretched polystyrene were supplied to the Contract Officer. The materials were:

Approximately 19 ft.<sup>2</sup> of polystyrene about 1/2-inch thick biaxially stretched at 115°C.

Approximately 19 ft.<sup>2</sup> of polystyrene about 1/2-inch thick biaxially stretched at 125°C.



Approximately 16 ft.<sup>2</sup> of polystyrene about 1/4-inch thick biaxially stretched at about 125°C.

Approximately 2.5 ft.<sup>2</sup> of polystyrene about 1/4-inch thick biaxially stretched at 115°C.

Approximately 2.0 ft.<sup>2</sup> of polystyrene about 1/4-inch thick biaxially stretched at 105°C.

Approximately 21 ft.<sup>2</sup> of polystyrene about 1/8-inch thick biaxially stretched at 115°C.

Ballistic test panel laminates of the polystyrene were also prepared and delivered to the Contract Officer. Because of unevenness of surface, high spots on the samples had to be sanded prior to laminating. Some air pockets were visible but the finished laminates were generally satisfactory.

Ten 6- by 6- by 3-inch blocks of hot-stretched polystyrene and one unstretched polystyrene as control panel were delivered to the U. S. Army Natick Laboratories.

## (2) Hot-Stretching of Polycarbonate

Most of the polycarbonate evaluated in this program was "Zelux" (R) molded sheet 1/4-, 1/2- and 1-inch thick. The supplier identified it as being molded from "Lexan" (R) molding powder. Some 1/2-inch and 1-inch-thick sheet identified as "Lexan" (R) was also obtained from another source as were 1/4-, 1/2- and 1-inch-thick sheet identified as molded from Mobay resin. No apparent differences among sources was observed except that one supplier was unable to press-polish sheet material and its material was therefore used only during initial uniaxial screening.

The polycarbonate was found to be less satisfactory in some ways than the polystyrene. Moisture absorbed in the sheets led to many bubbles throughout the samples when they were heated rapidly to stretching temperature, that is 170°C and up. The sheets were also found to contain large numbers of surface flaws and inclusions. Fitting was very common.

Moisture was removed from the sheets by preheating below the stretching temperature range. Heating for two hours at 130°C was found superior to long heating at lower temperatures because less discoloration of the sheet occurred. Polycarbonate always darkened somewhat during stretching.

Even prolonged heating did not completely eliminate bubbles in stretched sheets. It may be that some degradation of the plastic occurred at the temperatures necessary for stretching. The possibility of moisture attack from the combustion product water in the

heating atmosphere was checked. Both General Electric and Mobay technical personnel stated that heating in combustion gases at the temperatures used would not degrade polycarbonate. The atmosphere also contained a high excess of air over the stoichiometric ratio and was well below the saturation concentration of water so that hydrolysis of the resin was highly unlikely.

It was found that stretching could be obtained only in the narrow range of 170°C to 180°C. A nominal temperature of 175°C was therefore used for the majority of stretching trials. Draw rates from about 1 to 4 inches per minute were tried.

The heat transfer properties of polycarbonate were similar to polystyrene so that only slow heating and quenching rates could be obtained.

Draw ratios from 30 percent to 100 percent were tried but it was found that the polycarbonate tended to neck and thin in local spots. Therefore, the samples produced at higher draw ratios were highly variable in thickness.

#### (a) Physical Test Results for Polycarbonate

All tests run on polystyrene were also run on polycarbonate with the exception of Crack Propagation K Value. The test methods used were those cited for polystyrene in paragraph 5a(1)(a). It was found that cracks could not be initiated in polycarbonate under the specified test conditions. Instead of cracking when a sharp blade was driven into the sheet, it distorted and flowed.

As in the case of polystyrene, the samples tested were far from ideal because of the surface and internal defects mentioned above and because of the nonuniform thickness of the stock from which samples had to be taken.

The results of the tests are presented in Table IX. As compared to tensile and modulus values for controls shown in Table IV, the hot-stretched sheet showed only small increase in ultimate tensile strength and small decreases in modulus of elasticity. The orientation release stress for the polycarbonate samples prepared, based on comparison of all values obtained, seemed to be lower than that of polystyrene and acrylic samples and shrinkage on heating was small. The average orientation release stress values were 52.0 psi for polycarbonate, 63.9 psi for polystyrene and 94.7 psi for MIL-P-818+ acrylic. The values for each material showed a very large range between maximum and minimum.

Because of the limited range of variables possible, definite trends in physical properties are not shown.



Table IX

PHYSICAL PROPERTIES OF BIAXIALLY HOT-STRETCHED POLYCARBONATE

Sample Number	Nominal Stretch Temperature °C	Percent Stretch	Original Thickness inches	Stretch Rate in/min.	Tensile Strength psi	Modulus of Elasticity 10 <sup>5</sup> psi	Izod Impact ft.lbs./in.notch	Shrinkage Test % Vertical	Shrinkage Test % Horizontal	Crack Propagation K value	Orientation Release Stress lbs/in. <sup>2</sup>
141	175	50	1/4	4	10150 10800 12430 9780 10480 10820 Avg 10740	3.29 2.55 2.61 2.40 2.29 2.96 Avg 2.68				*	
143	175	50	1/4	4	10400 9820 9820 9040 8070 Avg 9430	3.47 2.96 2.80 2.72 2.98 Avg 2.98	5.00 4.61 2.95 4.06 3.54 Avg 4.03			*	
151	175	50	1/4	4	9740 9620 9440 9830 7720 9400 Avg 9290	2.98 3.00 3.11 2.90 1.42 3.14 Avg 3.03		0.0 8.7 11.6 2.9 11.6 5.8 Avg 6.8	8.7 2.9 2.9 2.9 0.0 2.9 Avg 3.4	*	
153	175	50	1/4	4	9700 9400 9550 9490 9490 9560 9730 Avg 9560	2.68 2.80 2.74 3.25 2.96 3.29 3.52 Avg 3.03				*	74.0 80.2 86.9 81.0 57.8 Avg 76.0

\* Unable to initiate crack.

Table IX (Cont'd)

PHYSICAL PROPERTIES OF BIAXIALLY HOT-STRETCHED POLYCARBONATE

Sample Number	Nominal Stretch Temperature °C	Percent Stretch	Original Thickness inches	Rate of Stretch in/min.	Tensile Strength psi	Modulus of Elasticity 10 <sup>5</sup> psi	Izod Impact ft. lbs / in. notch	Shrinkage % Vertical	Shrinkage % Horizontal	Crack Propagation K value	Orientation Release Stress lbs/in
169	175	50	1/2	1	8640	2.70		0.0	11.6	#	
					8290	2.98		2.9	2.9		
					8350	2.67		2.9	8.7		
					8560	2.60		11.6	8.7		
					8400	2.45		0.0	11.6		
					Avg 8470	Avg 2.68		2.9	0		
								2.9	2.9		
								Avg 3.3	Avg 6.6		
179	175	40	1/2	1	18200	4.68		15.2	9.1	*	37.8
					9880	3.02		15.2	0.0		34.6
					11600	4.24		9.1	9.1		36.6
					10100	2.44		12.1	12.1		40.2
					10050	3.29					
					Avg 11926	Avg 3.53		Avg 12.9	Avg 7.6		Avg 36.1
180	175	60	1/2	1	8820	1.90		0.0	3.3	*	37.8
					9050	2.93		0.0	0.0		33.1
					8760	2.93		0.0	0.0		36.8
					9130	2.12		3.3	0.		39.9
					9080	2.11		0.0	3.3		40.8
					9180	1.27		3.3	0.0		
					Avg 9033	Avg 2.21		Avg 1.1	Avg 1.1		Avg 37.7
145	170	50	1/4	4			2.69			*	106.5
							3.00				63.0
							1.81				69.9
							3.21				64.1
							3.26				62.1
							Avg 2.79				33.9
											Avg 64.7

\* Unable to initiate crack.

Table IX (Cont'd)

PHYSICAL PROPERTIES OF BIAXIALLY HOT-STRETCHED POLYCARBONATE

Sample Number	Nominal Stretch Temperature °C	Percent Stretch	Original Thickness inches	Rate of Stretch in/min.	Tensile Strength psi	Modulus of Elasticity 10 <sup>5</sup> psi	Izod Impact ft.lbs./in.notch	Shrinkage Test & Vertical	Shrinkage Test & Horizontal	Crack Propagation K value	Orientation Release Stress lbs/in. <sup>2</sup>
264	180	40	1	1	8580	2.88	2.55			*	34.4
					9223	3.03	2.49				43.1
					9215	2.85	3.23				59.0
					9813	2.93	3.50				55.6
					Avg9208	Avg2.92	2.60				34.6
							Avg2.87				Avg45.3

\* Unable to initiate crack.

### (b) Optical Test Results for Polycarbonate

As might have been anticipated from previous remarks on flaws, defects, nonuniformity and discoloration, the optical tests on hot-stretched polycarbonate were not as good as those on MIL-P-8184 acrylic samples. The optical values are given in Table X. The same procedures cited for polystyrene in paragraph 5a(1)(b) were applied to the polycarbonate. Pattern distortion seemed to be comparable to polystyrene results of Table VIII but Total Luminous Transmittance and Percent Haze were not as good. It is probable that defects and discoloration could be overcome by development work on the molding formulations of this plastic.

### (c) Materials Delivered

In accordance with contract requirements, several shipments of hot-stretched polycarbonate were supplied to the Contract Officer. The materials were:

Approximately 23 ft<sup>2</sup> of polycarbonate about 1/8-inch thick after biaxial stretching.

Approximately 5 ft<sup>2</sup> of polycarbonate about 1/4-inch thick after biaxial stretching.

Approximately 17.5 ft<sup>2</sup> of polycarbonate about 1/2-inch thick after biaxial stretching.

All biaxial stretching trials were made at 175°C ± 5°C.

Ten 6- by 6- by 3-inch blocks of hot-stretched polycarbonate and one unstretched polycarbonate block as control were laminated from layers of about 1/2-inch thick sheet using polyvinyl butyral film as adhesive. These 11 ballistic test panel laminates were delivered to the Contract Officer. As in the case of polystyrene, high spots in the layers of plastic were removed by sanding, sawing or cutting in a lathe.

### (3) Hot-Stretching MIL-P-8184 Acrylic

The standard material chosen for hot-stretching trials was MIL-P-8184 acrylic which is commercially available in stretched form. Specification material sheets 1/4-, 1/2- and 1-inch thick were obtained. A sheet 3/4-inch thick was also purchased. No apparent differences between sources was observed in the trial runs.

Work with the MIL-P-8184 acrylic, Plexiglas 55, indicated very clearly its unique behavior compared with the other plastic materials used. It was found that a rubbery state developed which permitted stretching to uniform thickness over almost an entire 12- by 12-inch sample sheet. A temperature range of 155° to 180°C was used and draw ratios up to 60 percent of the original sheet width were attained without too much difficulty at all thicknesses.

Table X

## OPTICAL PROPERTIES OF BIAXIALLY HOT-STRETCHED POLYCARBONATE

Sample Number	Nominal Stretch Temperature °C	Percent Stretch	Original Thickness inches	Rate of Stretch in /min.	Maximum Deflection inches	Frequency of Image Movement	Pattern Distance	Displacement Factor								
141	175	50	1/4	4	4.5	Irregular	60	180								
143	175	50	1/4	4	1.5	Irregular	60	60								
154	175	50	1/4	4	3.0	Irregular	60	120								
180	175	58	1/2	1	5.0	Irregular	60	200								
<table border="1"> <thead> <tr> <th>Total Luminous Transmittance</th> <th>Percent Haze</th> </tr> </thead> <tbody> <tr> <td>0.869, 0.867</td> <td>2.7, 2.5</td> </tr> <tr> <td>0.837, 0.835</td> <td>2.9, 3.1</td> </tr> <tr> <td>0.872, 0.870</td> <td>2.9, 2.7</td> </tr> </tbody> </table>									Total Luminous Transmittance	Percent Haze	0.869, 0.867	2.7, 2.5	0.837, 0.835	2.9, 3.1	0.872, 0.870	2.9, 2.7
Total Luminous Transmittance	Percent Haze															
0.869, 0.867	2.7, 2.5															
0.837, 0.835	2.9, 3.1															
0.872, 0.870	2.9, 2.7															

The development of techniques was the most important factor in attaining success with the hot-stretching of Plexiglas 55. It was found that notch effects from the cut edges and gripping holes could be eliminated by fire-polishing them with a propane torch. Distortion and cracking at the grip holes was overcome by careful control of cooling water flow using separate feeds for each of the four sides of the sheet. Cooling water temperature was held at about 40°C.

Thermal equilibrium in the sheet was attained by holding it at the stretching temperature for at least 45 minutes before pulling. Under these conditions, the sheet softness could be easily detected by manual tension on the pull cables.

Very little problem with Plexiglas 55 was encountered from surface imperfections or internal defects. Moisture was no problem and only slight discoloration resulted from heating. As a generality, large, clear, uniform thickness pieces were obtainable under all conditions of stretching tried.

#### (a) Physical Test Results for MIL-P-8184 Acrylic

Complete testing was done on the acrylic sheets after hot-stretching. The acrylic samples were much the best of the three plastics evaluated completely. High values of most properties were obtained.

The results of the tests are shown in Table XI. The test methods used were those cited for polystyrene in paragraph 5a(1)(a). In comparison with unstretched material shown in Table III, it is evident that biaxial hot-stretching resulted in less significant improvements in tensile strength, modulus of elasticity and crack propagation K value than comparable uniaxial stretching. The K values are also considerably lower than those for commercially available hot-stretched MIL-P-8184 sheet as previously reported in Table VI. These unanticipated results led to a designed experiment in which temperature and rate of stretch were chosen as variables and high and low extremes were used to draw samples by a fixed percentage. This experiment is reported in detail in a subsequent section.

#### (b) Optical Test Results for MIL-P-8184 Acrylic

The optical test results for MIL-P-8184 acrylic sheet stretched in this program were consistent with the visual appearance of the sheets produced. The optical test procedures cited for polystyrene in paragraph 5a(1)(b) were also used for the acrylic sample testing. As presented in Table XII, pattern distortion was undetectable, total luminous transmittance was very high and percent haze was very low. It is believed that the transmittance value is reduced somewhat by slight yellowing because of the heating history

Table XI

PHYSICAL PROPERTIES OF BIAXIALLY HOT-STRETCHED MIL-P-8184 ACRYLIC

Sample Number	Nominal Stretch Temperature °C	Percent Stretch	Original Thickness inches	Rate of Stretch in/min.	Tensile Strength psi	Modulus of Elasticity 10 <sup>5</sup> psi	Izod Impact ft.lbs./in.notch	Shrinkage & Vertical	Shrinkage & Horizontal	Crack Propagation K value	Orientation Release Stress lbs/in. <sup>2</sup>
191	165	25	1/4	1						1544 1350 1140 1260 1100 Avg1279	
194	165	25	1/4	1							34.8 27.2 7.0 37.2 Avg26.6
193	165	30	1/4	1	12638 12000 12409 Avg12349						
192	165	38	1/4	1	12202 12527 12200 12200 12644 12539 Avg12385	5.19 5.41 4.87 5.00 5.10 4.85 Avg5.07	.35 .48 .36 .39 Avg.39				
208	170	50	1/4	1				16.0 24.3 30.0 21.4 19.0 Avg22.1	19.0 24.3 18.4 21.4 24.3 Avg21.4		

Table XI (Cont'd)

PHYSICAL PROPERTIES OF BIAXIALLY HOT-STRETCHED MIL-P-8184 ACRYLIC

Sample Number	Nominal Stretch Temperature °C	Percent Stretch	Original Thickness inches	Rate of Stretch in/min.	Tensile Strength psi	Modulus of Elasticity 10 <sup>5</sup> psi	Izod Impact ft.lbs./in.notch	Shrinkage Test & Ver-tical	Shrinkage Test & Hori-zontal	Crack Propagation K value	Orien-tation Release Stress lbs/in. <sup>2</sup>				
218	170	50	1/2	1	12300	4.00		27.2	27.2		137.5				
					11550	4.28	26.4	27.2	149.0						
					12300	4.26	Avg26.8		138.0						
					11650	3.84			127.0						
					11900	3.76			134.5						
					Avg12191	Avg3.97				Avg137.2					
219	170	50	1/2	1	8640	2.70				1422					
					8290	2.98			1870						
					8350	2.67			1382						
					8580	2.60			2096						
					8490	2.45			1474						
					Avg 8470	Avg2.68				1673					
										1875					
										Avg1965					
214	170	50	1/2	1			0.35	23.4	30.7	1540	169.8				
							0.36	29.8	27.2	1920	92.6				
							0.35	33.8	24.6	1415	98.3				
							0.30	Avg29.0		Avg27.5		Avg1625		Avg120.2	
							Avg0.34								
304	170	50	3/4	2-1/2	12421	7.66									
					12174	5.04									
					12002	4.77									
					12151	Avg5.82									
					12276										
					Avg12204										



Table XII

OPTICAL PROPERTIES OF BIAXIALLY HOT-STRETCHED MIL-P-8184 ACRYLIC

<u>Sample Number</u>	<u>Nominal Stretch Temper- ature °C</u>	<u>Percent Stretch</u>	<u>Orig- inal Thick- ness inches</u>	<u>Rate of Stretch in./min.</u>	<u>Maximum Deflec- tion inches</u>	<u>Frequency of Image Movement</u>	<u>Pattern Distance</u>	<u>Displace- ment Factor</u>																																				
202	170	50	1/4	1	0.0	Single shift	25	0																																				
207	170	50	1/4	1	0.0	Single shift	25	0																																				
<table border="0" style="width: 100%;"> <tr> <td style="text-align: right;"><u>Total Luminous Transmittance</u></td> <td colspan="2"></td> <td colspan="2"></td> <td colspan="2"></td> <td colspan="2"></td> </tr> <tr> <td></td> <td>165</td> <td>50</td> <td>1/4</td> <td>0.924,0.922</td> <td colspan="2"></td> <td colspan="2">Percent Haze</td> </tr> <tr> <td></td> <td>170</td> <td>50</td> <td>1/2</td> <td>0.914,0.915</td> <td colspan="2"></td> <td colspan="2">0.5,0.5</td> </tr> <tr> <td></td> <td></td> <td></td> <td></td> <td></td> <td colspan="2"></td> <td colspan="2">1.1,0.9</td> </tr> </table>									<u>Total Luminous Transmittance</u>										165	50	1/4	0.924,0.922			Percent Haze			170	50	1/2	0.914,0.915			0.5,0.5									1.1,0.9	
<u>Total Luminous Transmittance</u>																																												
	165	50	1/4	0.924,0.922			Percent Haze																																					
	170	50	1/2	0.914,0.915			0.5,0.5																																					
							1.1,0.9																																					

Procedures: ASTM D637-50 and D1003-52.

during the hot-stretching process. The haze is a result of slight surface imperfections which were caused by the necessary handling of materials during hot-stretching and preparation of test samples. Improved techniques could probably reduce these scratch and rub marks to a much lower number with consequent improvement in optical values.

(c) Materials Delivered

In accordance with contract requirements, several shipments of hot-stretched MIL-P-8184 acrylic sheet were supplied to the Contract Officer. The materials were:

Approximately 17.7 square feet of MIL-P-8184 acrylic about 1/8-inch thick after biaxial stretching at a nominal temperature of 165°C.

Approximately 5.0 square feet of MIL-P-8184 acrylic about 1/4-inch thick after biaxial stretching at a nominal temperature of 170°C.

Approximately 16 square feet of MIL-P-8184 acrylic about 1/2-inch thick after biaxial stretching at a nominal temperature of 160°C.

Ten 6- by 6- by 3-inch blocks of hot-stretched acrylic and one unstretched acrylic block as control were laminated from layers of about 3/8-inch to 1/2-inch thick sheet using polyvinyl butyral film as adhesive. Slight sanding to remove thick spots at points near grip holes was necessary on some pieces to obtain even stacking of sheets in the blocks. In general, the acrylic was the most satisfactory material in lamination as in other properties.

(d) Effect of Hot-Stretching Variables on the Crack Propagation Test Results

As stated earlier, a designed experiment was run to check on the influence of hot-stretching variables on the results of the crack propagation test. The conditions chosen were:

Temperature - Low T, 155°C; High T, 175°C.

Rate of Stretching - Low R, 0.25 in/min; High R, 2.5 in/min.

Draw Ratio - 37.5%.

Two sheets at 155°C and two at 175°C were stretched, one at each rate. Crack propagation samples were then prepared from the four sheets and tested. The results of the crack tests are shown schematically in Figure 10. In this figure, the individual and average K values for each sheet are keyed by sample number.

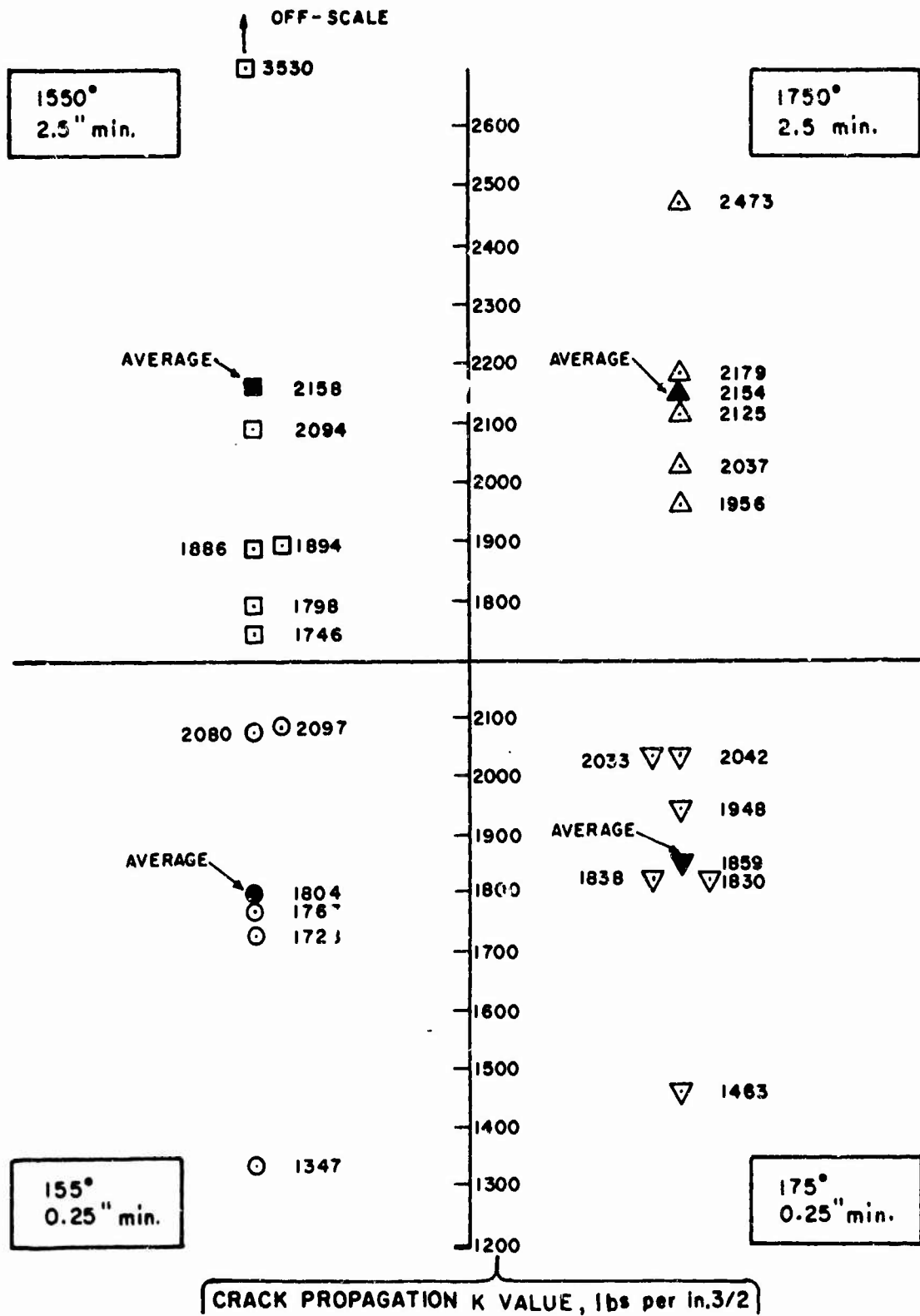

EFFECT OF HOT STRETCHING VARIABLES ON CRACK TEST RESULTS

FIGURE 10

The samples and conditions of stretching were:

<u>Sample Number</u>	<u>Nominal Temperature °C</u>	<u>Rate of Stretch in./min.</u>
308	155	0.25
313	155	2.50
312	175	0.25
311	175	2.50

All samples were quenched in the same manner.

As can be seen in Figure 10, temperature does not seem to be a variable which influences crack resistance strongly. On the other hand, an increase in the rate of stretching produces a substantial increase in the K value.

#### b. Screening of Other Plastics

In accordance with requirements of the program, seven additional plastics were screened for biaxial stretching behavior. The materials stretched were Plexiglas 1A, XT500 acrylic, polysulfone, polyphenylene oxide, nylon 6 and 66, cross-linked polyethylene and polypropylene. As a generality, none of these materials seemed promising except the acrylics Plexiglas 1A and XT500. There was some evidence that polyphenylene oxide might also be a potential candidate for further hot-stretching trials.

It should also be noted that most of the materials considered were not readily available in thicknesses of 1/4-inch or more. The sheet samples which were obtained were imperfect in surface and internal structure in many cases.

The practice of running a determination of heat distortion under dead weight load was adopted for exploratory testing of stretching behavior. A 1-kg weight was hung at the bottom of a 1/2 strip of plastic which was suspended in an air-circulating oven and observed at 10°C intervals.

Detailed discussion of the plastics screened is given in the subsequent parts of this section.

##### (1) Cross-linked Polyethylene

This material was obtained in 1/4-inch thickness. Stretching temperatures from 120° to 135°C were tried. It was found that the

sheet necked in a local area and subsequent stretching generated at the root of the necked area. As a result, patterns of very thin stretched plastic developed between islands of unstretched stock. Increased numbers of gripping holes and limited side motion of the grips by linking them with chains were tried without improvement.

It was concluded that cross-linked polyethylene was not a suitable candidate material for hot-stretching procedures.

No physical tests were performed on the sheets produced because of their nonuniformity.

One piece of the hot-stretched product was submitted to the Contract Officer for examination.

#### (2) Polypropylene

The polypropylene sheet tested was also 1/4-inch thick. The hot-stretching behavior of this material was very similar to that of polyethylene. The product was considered unsatisfactory for testing.

One piece of the hot-stretched product was submitted to the Contract Officer for examination.

#### (3) Nylon 66 and 6

Early work had been done with a sheet of material determined to be nylon 6. Because of the sharply defined, high flow temperature of this plastic, a sample of 1/4-inch-thick nylon 66 was obtained.

While the nylon 66 has a lower and less well-defined flow temperature, its hot-stretching performance was very similar to that of nylon 6. On heating the nylon began to degrade as shown by brown discoloration and distortion of the edges and corners of the sheet in the stretching unit. Attempts to overcome this degradation by preheating, coating with silicone mold release fluid and covering with mylar sheets were unsuccessful. The nylon stretched unevenly, shredded at the surface and tore at the exposed edges.

Two pieces of the hot-stretched nylon 66 were submitted to the Contract Officer for examination. No tests were performed on the biaxially stretched product.

#### (4) Polysulfone

A sample of Polysulfone (R) was obtained in 1/2-inch thickness. The preliminary dead weight test showed surprising instability of this plastic. At about 170°C it expanded into a foam structure and became very weak.

It was concluded that the polysulfone absorbed moisture as had been experienced with polycarbonate. Samples were therefore preheated at about 130°C before stretching. While foaming was reduced, it was not eliminated.

Two pieces were stretched at 215°C. At a draw ratio of 25 percent, the pieces began to tear inward from surface imperfections. There was evident deterioration and blowing in the sheets as well as tears at the edges and surfaces.

The two pieces were delivered to the Contract Officer. No testing was performed.

#### (5) Polyphenylene Oxide

Polyphenylene oxide sheet 3/8-inch thick was identified as Alphalux 400-PPO (R). The preliminary dead weight test showed rubbery flow at about 220°C. The sample which was originally a pale tan darkened considerably to a light brown during heating.

Two pieces of this plastic were stretched 33-1/3 percent at about 220°C. The pieces showed shredding and checking on the surfaces and edges as a result of imperfections in the original stock.

The stretched pieces were submitted to the Contract Officer. Because of the unsatisfactory nature of the surfaces, no testing was performed. The behavior of this material was, however, better than any other non-acrylic which had been screened.

#### (6) Plexiglas IA UVA

Sheet samples of Plexiglas IA UVA were clear, water-white and perfect in surface and internal structure. Preliminary testing showed a rubbery range from 120° to at least 140°C.

Two 1/4-inch and two 1/2-inch sheets were stretched under the conditions shown in Table XIII. One sample, #253, tore at the top grip holes during cooling. All the other samples gave pieces which looked better than any other material stretched in regard to color, uniformity, freedom from imperfections and stretching behavior.

Two pieces were cut into samples for crack propagation tests. The "K" factor values obtained are also shown in Table XIII. These values are lower than those found for commercially available hot-stretched Plexiglas 55. They are, however, comparable to values for Plexiglas 55 which were prepared under similar conditions.

The remaining two pieces of hot-stretched Plexiglas IA UVA were delivered to the Contract Officer for any further evaluation at the U. S. Army Natick Laboratories.

Table XIII  
 STRETCHING CONDITIONS AND CRACK PROPAGATION  
 TEST RESULTS FOR PLEXIGLAS IA UVA

<u>Sample Number</u>	<u>Original Thickness</u>	<u>Rate of Stretch</u>	<u>Stretching Temperature</u>	<u>Draw Ratio</u>
252	1/4	1"	138°C	75%
253	1/4"	3"	126°C	85%
254	1/2"	1"	130°C	40%
255	1/2"	1"	125°C	75%

Crack Propagation K Value, lbs./in.<sup>3/2</sup>

<u>Sample #253*</u>	<u>Sample #255</u>
1152	1867
893	2019
1484	1414
1005	<u>1860</u>
<u>1302</u>	Avg1790
Avg1207	

\* Sample cracked at grips on cooling.

(7) Modified Acrylic XT500

Several 10- by 10-inch pieces of modified acrylic XT500 sheet were hot-stretched. Both 1/8-inch and 1/4-inch-thick samples were used.

This plastic was rubbery in the range from 115° to 130°C. Two sheets 1/8-inch thick were stretched 80 percent at 130°C and one inch per minute. Three sheets 1/4-inch thick were stretched 40 percent at 115°C and one inch per minute. While the sheet became hazy when heated and stretched, it drew evenly at the lower temperature and gave a uniform product.

The two sheets drawn from 1/8-inch stock and two drawn from 1/4-inch stock were delivered to the Contract Officer. One piece of the product sheet from 1/4-inch initial thickness was tested for crack propagation. The "K" factor values were the highest for any material thus far examined, averaging 3719 lbs./in.<sup>3/2</sup> The individual test values are shown in Table XIV.

Table XIV  
CRACK PROPAGATION TEST RESULTS  
FOR MODIFIED ACRYLIC XT500

<u>"K" Value</u> <u>lbs./in.<sup>3/2</sup></u>
3554
3994
3318
<u>3368</u>
Avg3719



## 6. Conclusions

Although an extensive effort was applied to the study of the hot-stretching, the information gained was not as extensive as had been anticipated when the project started. The following conclusions are warranted from the work performed.

a. The process of biaxial orientation by hot-stretching gives obvious improvements in the physical properties of polystyrene and acrylic plastic sheets. Improvements in polycarbonate were much less noticeable under the conditions and processes used.

b. Most plastic sheets commercially available do not show good processing characteristics under the conditions used. Variable thicknesses, surfaces and visual appearances usually resulted from hot-stretching.

c. The crack propagation test does not seem to give a suitable correlation for predicting ballistic resistance and in fact seems to be somewhat unique to acrylic plastics as an indicator of biaxial strength improvement.

d. The correlation of physical property values measured with hot-stretching parameters is not clear. There is a suggestion from the data obtained that faster rates of stretching gave better properties than the slower rates.

e. No serious deficiency in optical properties other than discoloration due to heat history was apparent for any of the transparent plastics stretched.

f. A clearly evident difference between acrylic plastics and other materials was shown by the hot-stretching trials made. Acrylic sheets stretched with uniform thickness and maintained superior optical properties.

g. MIL-P-8184 and other acrylic plastic sheets were found to be much tenderer during stretching than the other plastics. Pieces drawn were highly notch sensitive and had no resistance to continuation of tear once a break initiated.

h. The difficulties experienced in this program suggest that another means of biaxial orientation, such as a pressing technique, might be more applicable to plastics other than MIL-P-8184 acrylic.

i. On the basis of the screening investigation performed, polyphenylene oxide sheet might be considered as a candidate material for further hot-stretching investigations.

j. In retrospect, concentration of present program effort on production of large amounts of sheet under uniform conditions consumed much time and material without much gain in information.

k. The equipment developed during this program is capable of biaxially stretching a large number of plastic sheet materials under a wide range of conditions. Suitable process technology has also been developed.

## 7. Recommendations

As a result of the work done on this program, a somewhat different insight into the process of biaxial orientation of plastics by hot-stretching has been obtained. At the start of the work, it was assumed that the knowledge and technology developed through work on acrylic plastic and thin films of other materials would apply to thick sheets and other plastics. These assumptions have proved erroneous.

At present, equipment, technology and excess materials are available for further development of improved plastic sheets. The following work is recommended as being appropriate for carrying forward research on the hot-stretching process. The recommendations are based on the assumption that biaxial orientation and ballistic resistance correlate and that ballistic resistance can be optimized for any given plastic.

a. The relationship between strength and ballistic resistance on the one hand and nature of the plastic sheet and its biaxial orientation on the other should be determined by an investigation more fundamental than the one reported here.

b. In future work, more emphasis is needed on characterization of material for the intended end use. Specifically, a better test than crack propagation is needed. A controlled impact penetration test suggests itself as more closely simulating test firings.

c. A better utilization of manpower and materials would result from greater emphasis on process techniques than on production of large amounts of hot-stretched materials. Again, a satisfactory screening test suited to the sample materials being produced and giving reasonable correlation with ballistic resistance should be available.

d. The equipment and materials available as a result of the present program should be used in future trials but an effort should also be made to conceive alternate equipment and methods which might produce better product sheets from non-acrylic plastics.

e. Several problems of hot-stretching programs became obvious during this work. Among them are those of unavailability of suitable commercial sheet materials, high material costs because of low yields of suitable product and inability to control quenching rate as an independent variable when thick sheet is stretched. It is recommended that future development work concentrate on lighter gauge sheet, 1/4-inch for example, until process technology is well developed.

f. In summary, two major recommendations are made: to develop a more definitive test method and to work toward a more fundamental understanding of ballistic resistance in plastics.

#### 8. Selected Bibliography

The listed publications on hot-stretched plastics are available and have been reviewed at Lowell Technological Institute Research Foundation.

Axilrod, B. M., M. A. Sherman, V. Cohen and I. Wolock, Effects of Biaxial Stretch-Forming, Modern Plastics, 30: 117, 184 (December 1952).

Batzdorff, A., J. J. Gouza and D. A. Hurst, The Investigation of Biaxially Stretched Acrylic Plastic, WADC Technical Report 54-619, AD 142087, Wright Air Development Center, Dayton, Ohio (November 1957).

Coddington, David M., Determination of the Acceptability of a Commercially Stretch-Formed Acrylic Aircraft Canopy, WADC Technical Report 56-491, AD 110619, Wright Air Development Center (December 1956).

Fortner, C. P. and P. Dalton, Oriented Thermoplastic Sheet and Film, Materials in Design Engineering, 50 (7): 94-99 (1959).

Gouza, J. J. and D. A. Hurst, The Investigation of Multiaxially Stretched Acrylic Plastic, WADC Technical Report 54-619, AD 93136, Part I, Wright Air Development Center (July 1955).

Hearn, Colonel John V., Chairman, Transparent Materials for Aircraft Enclosures, Transparent Materials Conference, AD 68326, Engineers Club, Dayton, Ohio (March 1955).

Kramer, Mary J., Methods of Measuring Birefringence of Aircraft Glazing Materials, NRL Report 4624, Naval Res. Laboratory, Washington, D. C. (October 12, 1955).

- Kramer, Mary J., The Use of the Conoscope for the Inspection of Hot-Stretched Aircraft Glazing Materials, NRL Report 4989, Naval Res. Laboratory, Washington, D C. (July 19, 1957).
- Murphy, J. L., Thermoforming Biaxially-Oriented Film and Sheet, Plastics Technology, 5 (10): 42-44 (1959).
- Peterlin, A., Structure of Drawn Polymers, AFML Technical Report 67-6, Air Force Materials Laboratory (December 1966).
- Ramasesham, S., Faraday Effect and Birefringence, Procs. Indian Academy of Science, 34 (A): 32-40 (1951).
- Stansbury, John G., Stretched Acrylic, Aeronautical, Engineering Review, 17 (1): 1-7 (January 1958).
- Wilde, A. F., J. J. Ricca and F. deS Lynch, Study of Dynamic Birefringence and Strain Produced in Transparent Polymers by Mechanical Impact, Technical Report 66-6-CM, AD 630913, U. S. Army Natick Laboratories, Natick, Mass. (February 1966).
- Wise, W. E. and E. Schiff, Progress Reports No. 1 and 2, Canopy Material Development, Convair, San Diego, Report No. 8706, AD 87698, 87699, (January 1955).
- Wittman, Robert E., Transparent Materials for Aircraft Enclosures, WADC-University of Dayton Conference, WADC Technical Report 57-421, AD 142041, Wright Air Development Center, Dayton, Ohio (October 1957).
- Wolock, I. and D. A. George, Effects of Multiaxial Stretching on Crazing and Other Properties of Transparent Plastics, SPE Journal, 12: 20-27 (February 1955).
- Wolock, I., B. M. Axilrod and M. A. Sherman, Biaxial Stretch-Forming of Acrylics, Modern Plastics, 31: 128, 204 (September 1953).
- Belgian Patent #625357 to E. I. duPont, Process for the Film Treatment of Thermoplastic Polymer Materials (1962).
- Belgian Patent #637744 to E. I. duPont, Process for the Treatment of Polyolefin Films (1963).

Unclassified

Security Classification

DOCUMENT CONTROL DATA - R & D		
<small>(Security classification of title, body of abstract and indexing annotation must be entered when the overall report is classified)</small>		
1. ORIGINATING ACTIVITY (Corporate author)		2a. REPORT SECURITY CLASSIFICATION
Lowell Technological Institute Research Foundation Lowell, Massachusetts		Unclassified
		2b. GROUP
3. REPORT TITLE		
A STUDY OF HOT-STRETCHING TRANSPARENT PLASTICS		
4. DESCRIPTIVE NOTES (Type of report and inclusive dates)		
Final Report - 30 April 1965		
5. AUTHOR(S) (First name, middle initial, last name)		
Allen S. Powell, Russell W. Ehlers and Stephen A. Orroth, Jr.		
6. REPORT DATE	7a. TOTAL NO. OF PAGES	7b. NO. OF REFS
July 1968	67	19
8a. CONTRACT OR GRANT NO.	8b. ORIGINATOR'S REPORT NUMBER(S)	
DA 19-129-AMC-844(N)		
a. PROJECT NO.	8c. OTHER REPORT NO(S) (Any other numbers that may be assigned this report)	
1P121401A150	69-19-CM: C&OM-53	
c. IC024401A329		
d.		
10. DISTRIBUTION STATEMENT		
This document has been approved for public release and sale; its distribution is unlimited.		
11. SUPPLEMENTARY NOTES	12. SPONSORING MILITARY ACTIVITY	
	U.S. Army Natick Laboratories Natick, Massachusetts 01760	
13. ABSTRACT		
<p>The effect of hot-stretching parameters on the uniaxial and biaxial orientation, physical properties and optical properties of transparent plastics was investigated. Stretching parameters included draw temperature, rate of drawing, percent stretch and rate of quenching from drawing temperature. Plastics on which complete evaluation of physical and optical properties was made were polystyrene, polycarbonate and MIL-P-8184 polymethyl methacrylate. Limited screening evaluation of the hot-stretching behavior of cross-linked polyethylene, polypropylene, nylon 6, nylon 66, Delrin (R), Celcon (R), polyphenylene oxide, polysulfone, Plexiglas 1A (R) and XT500 modified acrylic was performed uniaxially and/or biaxially. Substantial amounts of biaxially stretched sheet 1/8-inch, 1/4-inch and 1/2-inch thick were supplied to the U. S. Army Natick Laboratories. Laminated panels of hot-stretched polystyrene, polycarbonate and MIL-P-8184 acrylic sheets were also submitted for ballistic resistance tests.</p> <p>Acrylic materials were found to be more amenable to hot-stretching than other plastics. No clear correlation between stretching parameters and improved physical properties was found. A versatile hot-stretching unit and a process technology to apply it were developed.</p>		

DD FORM 1473

REPLACES DD FORM 1473, 1 JAN 54, WHICH IS OBSOLETE FOR ARMY USE.

Unclassified  
Security Classification

14 KEY WORDS	LINK A		LINK B		LINK C	
	ROLE	WT	ROLE	WT	ROLE	WT
Stretch forming	8		6			
Stretching	8		6			
Hot working	8		6			
Parameters			6			
Biaxial			0			
Uniaxial			0			
Orientation			7			
Physical properties			7			
Optical properties			7			
Plastics	9		9			
Transparent	9		0			