

AD 673432

DEVELOPING AREA TRANSPORTATION SYSTEM STUDY

SAI R-10062

PROGRAM FORMULATION

S. Lampert; W. C. Ramsay; and C. R. Walli

Sponsored By

ADVANCED RESEARCH PROJECTS AGENCY
PROJECT AGILE
DEPARTMENT OF DEFENSE
ARPA ORDER NO. 1027
DATED 24 MAY 1967

UNDER CONTRACT DAHC04-67-C-0063
U. S. ARMY RESEARCH OFFICE - DURHAM
DURHAM, NORTH CAROLINA

February 1968

SYSTEMS ASSOCIATES, INC.
110 WEST OCEAN BLVD.
LONG BEACH
CALIFORNIA

167
CLEARINGHOUSE
for Research Reports and Documents
National Science Foundation

**BEST
AVAILABLE COPY**

DEVELOPING AREA
TRANSPORTATION SYSTEM
STUDY

PROGRAM FORMULATION
FEBRUARY 1967

PREPARED BY:

S. LAMPERT
W. C. RAMSAY
C. R. WALLI

SPONSORED BY:

ADVANCED RESEARCH PROJECTS AGENCY
PROJECT AGILE
DEPARTMENT OF DEFENSE
ARPA ORDER NO. 1027
DATED 24 MAY 1967

UNDER CONTRACT DAHC04-67-C-0003
WITH U. S. ARMY RESEARCH OFFICE-DURHAM
DURHAM, NORTH CAROLINA

FOREWORD

This report was prepared by Systems Associates, Inc., 110 West Ocean Boulevard, Long Beach, California, for Advanced Research Projects Agency Project AGILE, ARPA Order 1027, under Contract DAHC04-67-C-0063, U. S. Army Research Office - Durham, Durham, North Carolina.

In addition to SAI personnel, Dr. S. Lampert, Dr. W. C. Ramsay and Dr. C. R. Walli, who performed this study, assistance and consultation were provided by Mr. John L. Thousand in vehicles and mobility and by personnel of Simthesis, Incorporated, in detailed FORTRAN programming used for NETSIM and SIMDATS.

The authors wish to acknowledge the able assistance and direction by Dr. A. Barber, who supervised this program for ARPA. They further acknowledge the cooperation of the Joint-Thai-U.S. Military Research and Development Center, Thailand, in particular, Lt. Colonel Peter Kostoff, program manager, Mobility, and Major Miles Farmer and Major Nori, who accompanied the SAI team during the field trip to Northeast Thailand.

ABSTRACT

The objective of this program is to develop the process for formulating the plan for a Developing Area Transportation System (DATS). This plan must account for those factors involving the security of a particular region and their interaction with those associated with its uniform socioeconomic growth.

The process described in this report is the initial phase of a four-phase program. It is concerned with the synthesis of a transportation system that may be used for determining the adaptability of various systems options involving socioeconomic and security factors as they relate to the developing area requirements.

A simulation program SIMDATS has been devised which represents the system under consideration. This simulation may be used in part or in total for validating a particular approach by simulating conditions in an actual region. Such "sub-simulation" programs were developed and used during this study of a representative region of Northeast Thailand. The typical data used in these simulations were obtained by the SAI team who visited the area during this study period.

This report is subdivided into three major parts which are:

- I Program Synopsis
- II Program Description
- III Appendices

TABLE OF CONTENTS

I. PROGRAM SYNOPSIS

INTRODUCTION	S-1
ROLE OF TRANSPORTATION SYSTEM IN A DEVELOPING AREA	S-1
STUDY APPROACH	S-1
SELECTION CRITERIA AND NETWORK EVALUATION	S-3
SIMULATION PROGRAMS	S-4
SITE SURVEY - REPRESENTATIVE CASE	S-6
FORMULATION OF PLAN	S-7

II. PROGRAM DESCRIPTION

INTRODUCTION	1
GENERAL DESCRIPTION	3
NETWORK	3
ROAD-VEHICLE SYSTEM	3
SYSTEM CRITERIA AND REQUIREMENTS	5
SYSTEM MODEL FORMULATION	7
APPROACH	7
KEY MODEL ELEMENTS	8
THE INCREMENTAL MODEL	9
THE SYSTEMS MODEL	10
SIMULATION PROGRAM SUMMARY	11
SYSTEM APPLICATIONS	14
SECURITY APPLICATIONS	14
SOCIOECONOMIC APPLICATIONS	16
SECURITY-SOCIOECONOMIC MODEL SYNTHESIS	20
CASE STUDY - NORTHEAST THAILAND	22
FIELD SURVEY - SAMPLE REGION	22
SPECIFIC CASES - CALCULATED SOLUTIONS	24
THE DATS PROGRAM PLAN	46
PHASE 1 - CONCEPTUAL STUDY	46
PHASE 2 - DEFINITION AND DESIGN	46
PHASE 3 - VERIFICATION-PILOT STUDY	50
PHASE 4 - TOTAL TRANSPORT PLAN	51

III. APPENDICES

A.	SIMDATS PRELIMINARY TRANSPORTATION SIMULATION PROGRAM	52
B.	TRANSPORTATION NETWORK CHARACTERIZATION	75
C.	THE SECURITY STATION PROBLEM	82
D.	ALLOCATION OF RESOURCES TO MINIMUM SUPPLY DEPOTS	85
E.	NETSIM COMPUTER PROGRAM DESCRIPTION	90
F.	NETSIM PROGRAM CAPABILITY	100
G.	THE DEVELOPMENT OF ECONOMIC CRITERIA	115
H.	THE ECON-ILP MODEL	119
I.	DOCUMENTATION OF THE ECON-ILP COMPUTER PROGRAM	122
J.	OFF-ROAD AND PRIMITIVE ROAD MOBILITY: ROAD/VEHICLE FACTORS	126
K.	VEHICLE-TERRAIN EXAMPLE: A VELOCITY FIELD ASSIGNMENT CRITERION	134
L.	NOMENCLATURE	137
M.	REFERENCES	139

LIST OF FIGURES

<u>Figure Number</u>		<u>Page</u>
S-1	INCREMENTAL MODEL DETERMINATION	S-2
S-2	TYPICAL FLOW ILLUSTRATING NETWORK SELECTION	S-3
S-3	ROAD IMPROVEMENTS ECONOMIC MODEL	S-5
S-4	SECURITY STATIONS - WET WEATHER	S-5
S-5	SECTOR OF NAKHON PHANOM	S-7
S-6	FLOW DIAGRAM FOR DATS PROGRAM PLAN	S-8
1	VEHICLE-ROAD COMPATIBILITY	4
2	TRANSPORTATION SYSTEM MODEL	8
3	INCREMENTAL MODEL	10
4	VEHICLE-NETWORK SUBSYSTEM MODEL	11
5	GENERAL FLOW DIAGRAM INITIALIZATION	12
6	GENERAL FLOW DIAGRAM: PERFORMANCE	13
7	TRANSPORTATION SYSTEM ELEMENTS AND SYNTHESIS	17
8	SECTOR OF NAKHON PHANOM SHOWING ROUTES TRAVELLED BY SAI STUDY TEAM	23
9	SAMPLE REGION: A SECTION OF NAKHON PHANOM PROVINCE IN NORTHEAST THAILAND	26
10	SECURITY STATIONS: JEEP TRANSPORT DRY WEATHER $T_R = 1.10$ HOURS	27
11	SECURITY STATIONS: JEEP TRANSPORT $T_R = .30; .40; .50, \text{ and } .60$ HOURS	28
12	REACTION TIME ACHIEVED VERSUS MONEY SPENT/YEAR ON STATIONS	29
13	FASTEST PATHS FOLLOWED IN MEETING THREATS	31
14	TIME TICKS: TRAVEL CONTOURS	31
15	SECURITY STATIONS (RESTRICTED CHOICE)	31
16	SECURITY STATIONS (VEHICLE EFFECTS) - WET WEATHER NETWORK	34

<u>Figure Number,</u>		<u>Page</u>
17	SECURITY STATIONS (ROAD CONSTRUCTION EFFECTS)	35
18	ROAD MODIFICATION AND REACTION TIME	35
19	MINIMUM REACTION TIME ACHIEVED VERSUS TOTAL COST/YEAR	36
20	HELICOPTER SECURITY STATIONS	37
21	PLANNER'S PRESECTION OF ROAD IMPROVEMENT POSSIBILITIES	38
22	RELATIVE ECONOMIC WEIGHTS	38
23	ROAD IMPROVEMENTS CHOSEN BY ECONOMIC MODEL (10, 000/YR BUDGET)	39
24	ROAD IMPROVEMENTS CHOSEN BY ECONOMIC MODEL [a. 20, 000/YR b. 30, 000/YR]	40
25	PERCENTAGE REDUCTION IN REGIONAL PRICE LEVEL	40
26	SECURITY STATIONS WITH ADDED SOCIOECONOMIC FACTOR: ROTE VEHICLE WET WEATHER	43
27	SECURITY STATIONS REQUIREMENT REDUCED BY ECONOMICS- ORIENTED ROAD CONSTRUCTION	44
28	COSTS OF STATIONING AND ROAD-LEVELLING	45

LIST OF TABLES

<u>Table Number</u>		
1	INCREMENTAL MODEL SAMPLE DESCRIPTOR SET	9
2	ROAD/VEHICLE NETWORK DATA EXAMPLES	23
3	ROAD COSTS	23
4	EXTRACTS FROM SCHEDULE AT ARD OFFICE NKP	24
5	ROAD SEGMENTS, CONDITIONS AND LENGTHS	30
6	AVERAGE TRAVEL SPEEDS ADOPTED FOR VEHICLES IN EXAMPLE	30
7	SECURITY STATION SOLUTIONS FOR VARIOUS REACTION TIMES (JEEP-DRY SEASON)	32
8	"WET SEASON SECURITY STATION SOLUTIONS	33
9	"REALISTIC" RESTRICTIONS ON SUPPLY POINTS	34
10	COST-EFFECTIVENESS OF REGION'S ROAD SEGMENTS	39
11	"SEGMENT FACTORS"	41

DEVELOPING AREA TRANSPORTATION
SYSTEMS STUDY

I. PROGRAM SYNOPSIS

BLANK PAGE

PROGRAM SYNOPSIS

INTRODUCTION

Transportation, which provides the means for the exchange of goods and services and for the mobility of the population within the constraints imposed by geography, climate, and financial resources, represents an essential ingredient to any developing economy and a salient factor for insuring its security. This study is concerned with the planning of transportation systems for developing areas, taking into account those factors involved with social-economic development and the security needs. It is postulated that a region demonstrating growth potential does not of itself possess the ability to "bootstrap" its economy. By studying the inherent characteristics of a region -- its resources, population distribution, and security environment -- figures of merit may be determined which identify its potential, relative importance, and value warranting a capital investment for its development within the larger national community. Once the figure of merit has been established, the next stage is concerned with the planning for its development.

Such a plan as it relates to transportation will include the collection and evaluation of data, the analysis of existing conditions, and the determination of requirements as they relate to the evaluation of the region and its projected economic and social growth. Inherent to and characteristic of such regions of interest is the requirement that the security be maintained at levels which do not inhibit or disrupt this growth. Therefore any formulation must incorporate factors that allow for the needs and eventualities associated with effective security and defense of the region.

While this phase of the study was restricted primarily to surface transport modes and to conditions involving specific regions, the rationale developed may be extended to encompass the more general problem including all modes of transportation and more complex inter-regional networks.

ROLE OF TRANSPORTATION IN A DEVELOPING AREA

The single most important element pacing regional development is the transportation system, since it interacts with almost every facet of regional planning and must be accounted for at every stage. For example, the location and growth of communities and industries is strongly affected by

the transportation network just as the cost of major projects becomes dependent upon good transportation facilities. The accessibility of educational institutions, medical centers, etc. are facilitated by their proximity to the network. Arterial links may provide the network around which the communication and irrigation systems can be developed. All these situations and options directly interface with the regional planning of transportation. Similarly, the security problem is directly influenced by the location and layout of the transportation network - since police patrol activity and movement of security forces are dependent upon such facilities for making their presence felt. As demonstrated in this report, the strategy used in locating and deploying security forces can be markedly influenced by their mobility and the nature of the transportation system.

The formulation of a transportation plan with sufficient flexibility to account for these diverse elements, and a rationale to be employed are described herein. While the evolution of a total plan for a developing area transportation system encompasses a number of detailed stages (conceptual, design, test and verification) this portion of the study, in effect, the conceptual phase is devoted to establishing an approach to be employed in the formulation. The identification of the principal stages and the analysis and evaluation methods are presented in subsequent sections of this report, while some of the more salient features of the study are summarized in this section.

STUDY APPROACH

The approach taken in this study may be thought of as consisting of three parts, a division which lends flexibility to the planning exercises. The first is concerned with the gross layout of the transportation network based on existing or projected requirements involving the regional growth. The second step is concerned with those elements involved with the mechanization, i. e., types of roads, vehicles and costs, of the network and the development of the mathematical models that would be employed. The third stage involves the synthesis of the preceding into a representative simulation model descriptive of the transportation system. Such a simulation model has been structured during this phase and is referred to as SIMDATS, (Simulation of Developing Area Transportation System).

Network Layout

This part involves the layout of the transportation network based upon various types of usage criteria (economic, political, and security). The network consists of nodes or locales described as supply-and-demand points between which it would be desirable to establish a network link. Initially each node is assigned a relative value of importance based upon factors involving population, proposed economic development, strategic location for security, political or prestige values, social-cultural, and religious importance. The importance of the nodes in turn provide a starting point for determining usage factors for the various links connecting the nodes. By rank ordering the roads in the region based upon their postulated usage, a priority system for those roads may be established. The network so constructed may be varied by changing the importance of the nodes which in turn influences the usage potential of the links in the system and changes the priority rating of the roads. In this manner network maps may be evolved predicated upon particular usage criteria as well as desired performance requirements. It remains therefore to determine a method for mechanizing these networks so that their effectiveness in meeting the needs ascribed can be determined.

Mechanization and Incremental Model

This part, which in effect may be conducted separately, relates to the establishment of models for evaluating the engineering complexities and for determining the cost vs. performance of the vehicle-road combinations that could be employed with the network. To this end it was found useful to employ an incremental model which may be

thought of as representative of segments or elemental building blocks which when pieced together establish the characteristics of the link between the principal nodes in the network. These incremental models represent the physical characteristics to be encountered along specific segments in the link. The length of the segment may be varied depending upon the extent that a given terrain or physical environment persists along a desired link. For example, if between two principal nodes of the network it is desirable to establish a link of a particular quality, the link is subdivided into segments characterizing the physical environments: hills, creeks, paddy-land, etc. Each condition exposes a different situation which may be simulated by the incremental model. Each incremental model in turn may be assigned costs for construction, improvement or maintenance and described in terms of the performance to be expected for different vehicles over these segments as a function of road or terrain condition.

The method for selection of a particular incremental model may be characterized as shown in Figure S-1 where the vehicle-road compatibility may be determined and the resulting system evaluated in terms of costs for construction, maintenance or improvements, along with the expected performance. In this way all admissible combinations may be examined.

This approach not only provides flexibility to the mathematical simulation where segments of road may be varied systematically but also lends itself readily to devising test and verification programs (vehicle-road interaction) associated with each typical segment. As actual data becomes available it may be directly inputted into the simulation program. These segments then are combined

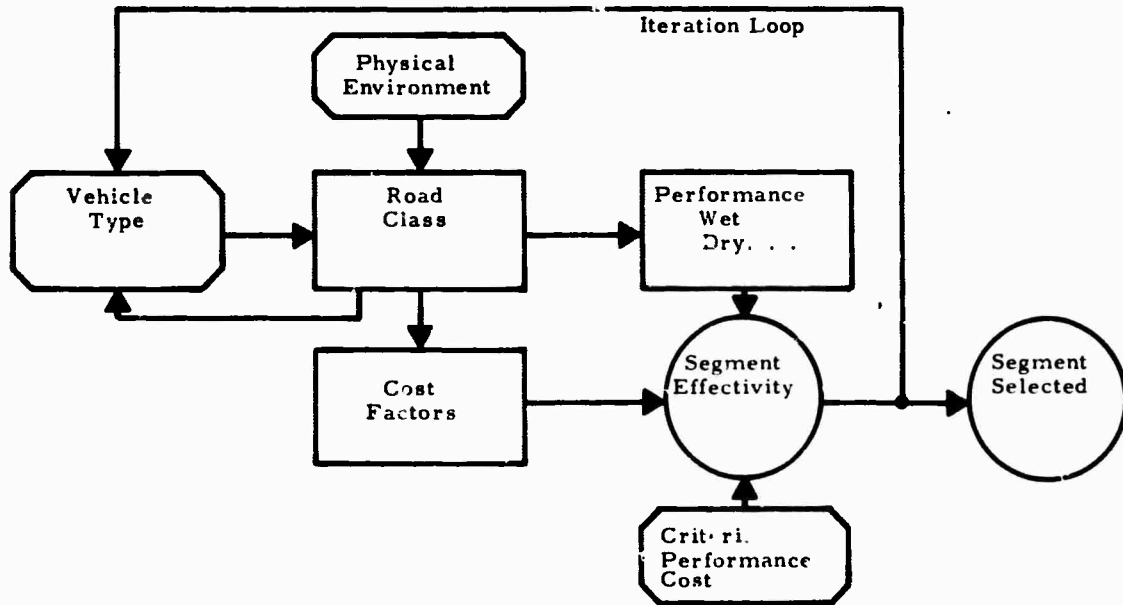

Figure S-1. Incremental Model Determination

to represent the network, wherein the integrated values determine vehicle performance and the total cost for each link in the network.

Synthesis

The final stage as implied is involved with the simulation of the total system so that the final model network may be varied, where for a given network the type and quality of the roads, or paths, constituting the links may be established along with the typical performance that could be expected for various classes of vehicles. As indicated previously, such a synthesis is represented by the SIMDATS Program which involves the total transportation system simulation. Certain "sub-simulations" NETSIM and ECON-ILP, were developed and used during this study to demonstrate the utility of the SIMDATS Program.

SELECTION CRITERIA AND NETWORK EVALUATION

The mathematical model devised to simulate the network described above can be used to help establish criteria or to evaluate requirements for roads based on social-economic-political or security needs.

In general the developing area's growth is shaped by its socio-economic need. Therefore it follows that an initial exercise involves the design of a network satisfying those needs (which may also exhibit political implications where the network is an indication of governmental presence and interest). While the economic-social-political factors do provide necessary criteria, and inputs to the transportation plan, they in themselves are insufficient and perhaps unrealistic when the security of the region is threatened by insurgency. Therefore provisions must be made in transportation planning to incorporate the existing and projected needs of the police and security forces. This implies that the social-economic-political requirements must be reconciled with those involving the insurance of security. Situations can occur in which security requirements tend to overshadow all other factors. If this is indeed the case, it will be desirable to plan the network so that long term economic benefits may be derived from these military/security developments. Whichever situation takes precedence it is possible, using the techniques developed here, to arrive at a compatible solution reconciling both types of criteria. An example of an approach that can be employed is demonstrated in the accompanying logic diagram. (Figure S-2) Here the system selected to satisfy specific socio-economic factors is constrained by security-imposed requirements. The following steps in this procedure are described for obtaining cost effective solutions:

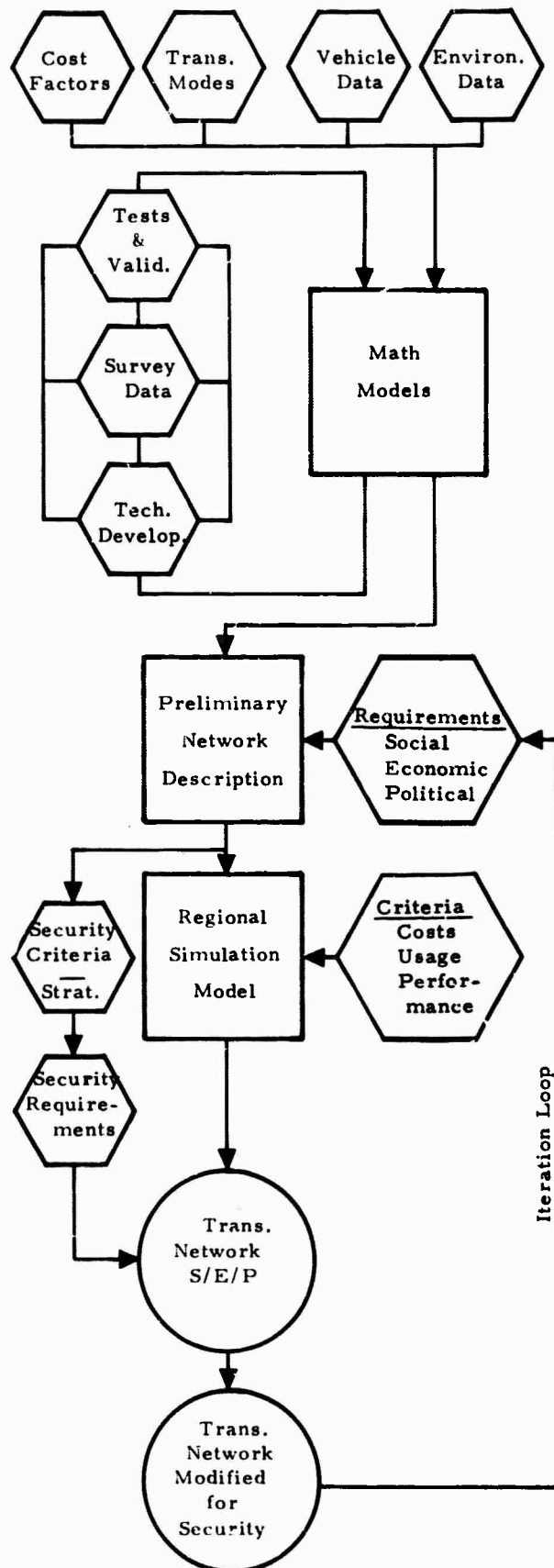

Figure S-2. Typical Flow Illustrating Network Selection Process

1. Identify a transportation network based upon social, economic, or political requirements.
2. Determine, on some priority basis, which roads and trails in the network should be constructed, improved, or maintained.
3. Determine the anticipated performance and costs associated with existing or projected links of network for varying weather conditions and vehicular configurations.
4. Establish a schedule for this system as a function of budgeted or allocated funds.
5. For the initial network and for a given mobility capability, determine whether an acceptable solution exists for force location and deployment which permits the force to effectively patrol and reach all the "important" points within the region in an "acceptable" reaction time. (This reaction time must be determined independently.)
6. If the force locations are fixed, determine the extent of their influence as a function of admissible reaction times.
7. Alter the network, as necessary to enhance security capability.
8. Perform an iteration with the amended road system to determine the effect upon the planned social/economic/political network.
9. This process may be repeated until the requirements of security and social economic needs are reconciled so that the system represents the best cost-effective solution.

SIMULATION PROGRAMS

Two subprograms were developed during the study to illustrate the capability provided by the comprehensive SIMDATS program, and were applied to several characteristic problems to demonstrate the program capability.

ECON-ILP Program

The economic simulation model ECON-ILP was employed to analyze those problems associated with road construction decisions. That is, given a limited budget for road construction in a region, which roads should be constructed or upgraded? To answer this question, one must

determine the anticipated flow rate over the proposed roads to determine which of the candidate roads demonstrates the greatest utility. Predicting this relative flow from empirical data would be difficult, even if the present usage of roads were known. In many cases of interest to the planner, even present usage is unknown. To circumvent this difficulty, the ECON-ILP program calculates an inferred road usage by making "simulated shipments". The number of simulated shipments on a road segment depends on two basic parameters, the cost-efficiency of transport along the segment and the economic demand at populated places along the road. Once the amount of goods shipped has been derived in this simulated manner, the road budget can be spent in such a manner as to maximize the goods shipments, or, equivalently, to minimize average transport costs or the consumer price level.

A sample result of such a calculation is shown in Figure S-3, where the roads recommended for improvement by the simulation model are shown. The simulation result shown is, of course, a model result: the required input data involving the economic demand at node points and the cost-efficiency of roads should be collected in a manner that allows for statistical testing in order to derive a reliable, real-world planning recommendation. The "economic demand" should be derived from reliable population, industrial, and agricultural statistics, while the road cost-efficiency determinations involve either pilot studies or accurate data on relative consumer prices.

With this caveat, however, the model results appear intuitively reasonable, and the ECON-ILP program does exhibit potential as an economic planning tool.

Additional problems which can be treated by means of SIMDATS techniques include the optimization of vehicle inventories, which again would require field tests; and the simulation, which involves the introduction of other capital items, such as irrigation systems and power plants.

The potential displayed by ECON-ILP, or a similar program is its use in a dynamic, "staging", type of calculation. That is, the introduction of new roads can be simulated, then the effects of those roads in changing the economy of the region can be introduced. The road construction (or vehicle change, or irrigation system construction) simulation can be reapplied using these new economic values.

NETSIM and Security Problems

The mathematic simulation model takes as inputs various road-vehicle-weather combinations and produces as outputs the minimum travel times between all points in the network, the routes followed on these paths, and solves the "stationing problem". The solution to

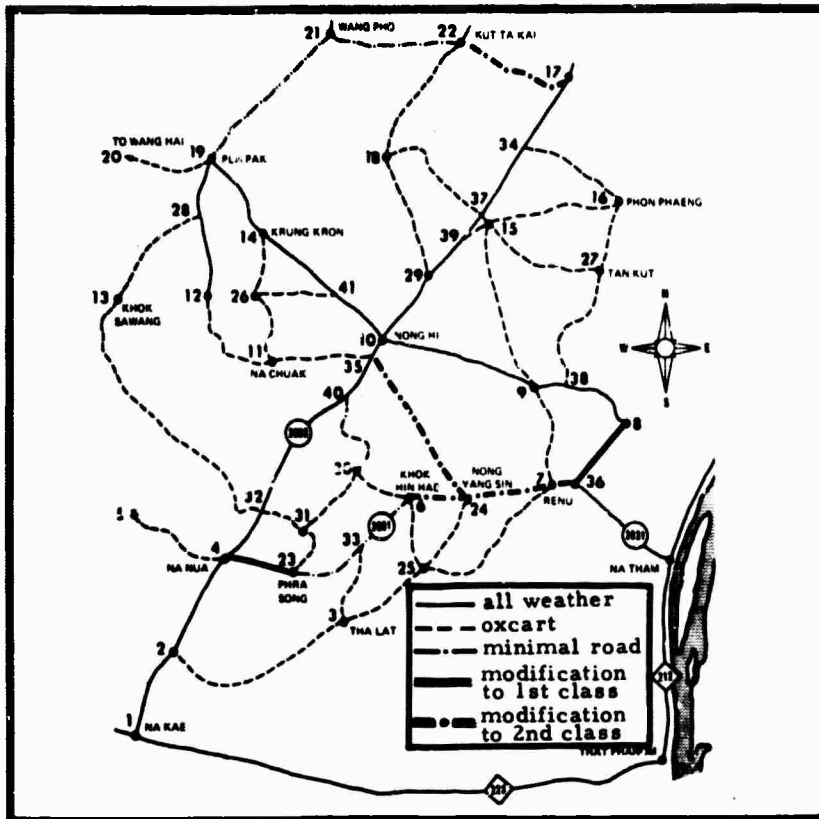

Figure S-3. Road improvements chosen by economic model as causing greatest reduction in regional consumer price level, if the road construction and maintenance budget is limited to \$20,000/year.

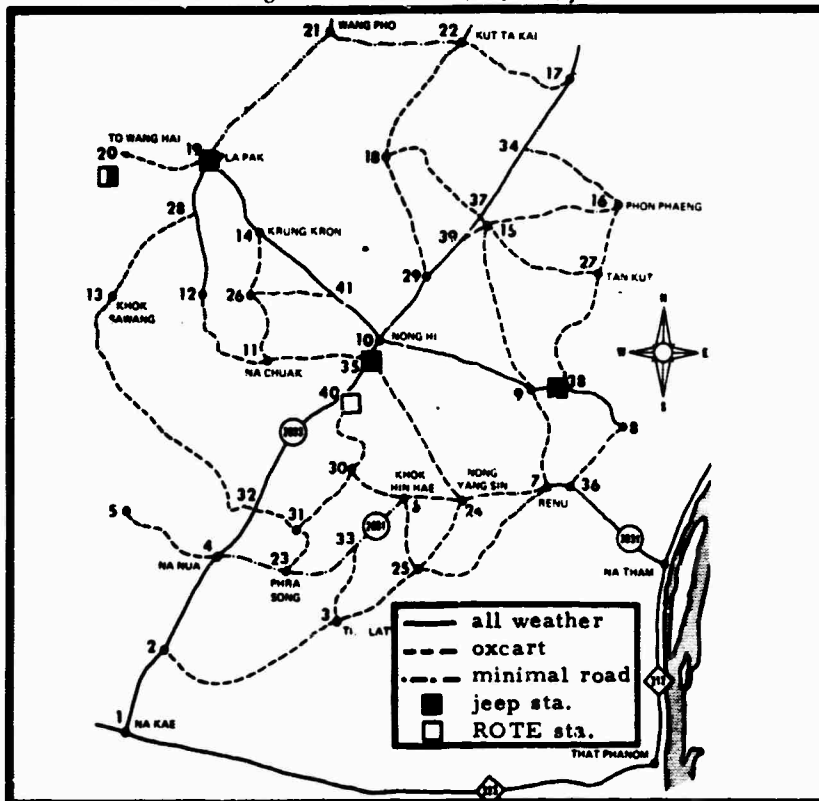

Figure S-4. Security stations required to cover area within 1.2 hour. Wet weather network, stations required for jeep travel versus those required for ROTE (special low-ground-pressure) vehicles.

this stationing problem gives the number and location of "supply" (security force) stations needed to get a security patrol unit to any set of designated points in the network within a specified "reaction time".

This reaction time can be varied, as can the road, vehicle and weather inputs, and resulting effects on the security station requirement analyzed. For example, the effect of substituting special low-ground-pressure (ROTE) vehicles for standard vehicles can be examined; Figure S-4 shows the result of a typical calculation of this kind. Other examples treated involve the effects of improving the network by road construction, and the effect of weather conditions, on stationing requirements. Other variables of the problem can be changed: the location of stations can be fixed beforehand, or the need for security forces can be taken to vary from point to point; examples of these cases are included in this report.

The allocation (stationing) solutions can be used for a great many other problems not explicitly treated in this study. Scheduling of patrols, planning of stratagems against ambushes, and, deployment of troops in tactical situations are problems which can be treated by SIMDATS methods or by simple adaptations of SIMDATS methods. Particular problems, such as ambush prevention or counter-ambush techniques, may require the introduction of probabilistic considerations into the present framework of the SIMDATS program. However, the crucial problems of identification of key parameters and the development of a central logical framework have been usefully treated, and the results achieved so far could form the basis for immediate, fruitful extensions into related problem areas.

Security - Socioeconomic Feedback

The simulation program, which can be used to treat economic and security problems separately as described above, can of course, be applied to the interaction of security and socioeconomic considerations. Examples are given in the report of the effects produced on the regional economy by roads built for police purposes. Quantitative (model) descriptions are made of the factors to be optimized in each case. That is, for security purposes, reaction time is to be made as fast as possible for as low a cost as possible; roads are built (in simulation) in an effort to achieve this optimization. Then the effect of those roads on the transport costs (or average consumer price level) of the region is calculated.

Conversely, the economic road-building model can be applied to recommend the most cost-effective construction or improvements to be carried out. These recommendations can be then examined as they relate to the security situation: the reductions in reaction time and decreases in

stationing costs can be calculated, as they are in an example in the report.

In general, one can use the comprehensive framework developed in the program, for the correlation of data and the solution to certain logical problems, to treat a large number of situations involving transportation and its effects on society.

SITE SURVEY-REPRESENTATIVE CASE

The simulation programs described contain an inherent flexibility for performing the analysis required for decision making relative to the transportation network. Various parts of the total simulation program SIMDATS may be employed to analyze the transportation requirements for special cases and conditions. In order to demonstrate the utility of this approach before progressing to the next stage in the development, involving more definitive and detailed data, the ECON-ILP and NETSIM programs were used to simulate conditions descriptive of a scenario concerned with a relatively underdeveloped region adjacent to, but having limited access to a main highway. To add realism to this situation, it was desirable to find a region that matched the scenario and to send observers to survey the existing conditions and to gather pertinent data for the simulation. In this way the problem could be evaluated for an actual situation.

The general area selected was in the province of Nakhon Phanom in northeast Thailand. The region is bounded on the north by Route 22, on the south by Route 223, on the west by the Changwat boundary, and extends to the Mekong River on the east. The particular region, shown in the accompanying map, Figure S-5, includes the environs of King Amphoe Pla Pak. This region was surveyed from the air as well as on the ground. These surveys were performed during the dry weather conditions for Northeast Thailand in December 1967. The vehicle employed over the road network was an MRDC radio jeep carrying four passengers. The road traversed (as indicated on the map) were rated as to average speed of jeep over the various links; such data are typical of those required for the simulation program. These routes consist of two-way laterite all-weather roads, dry season pioneer roads, and unpaved stretches of oxcart trails. In general, it was possible to traverse laterite roads at an average speed of 40 mph, while over sundry paddyland and jungle trails could be accomplished at 5 - 10 mph. Buses and trucks were observed traveling the two-way all-weather routes such as 22, 212, and 223 at speeds comparable with the jeep speed. An approach employed in this example was to rate the roads or paths for this "base point" dry weather condition and to ascertain the effectiveness of this road network for various security/police coverages which might employ jeeps to enhance their mobility. The results of the

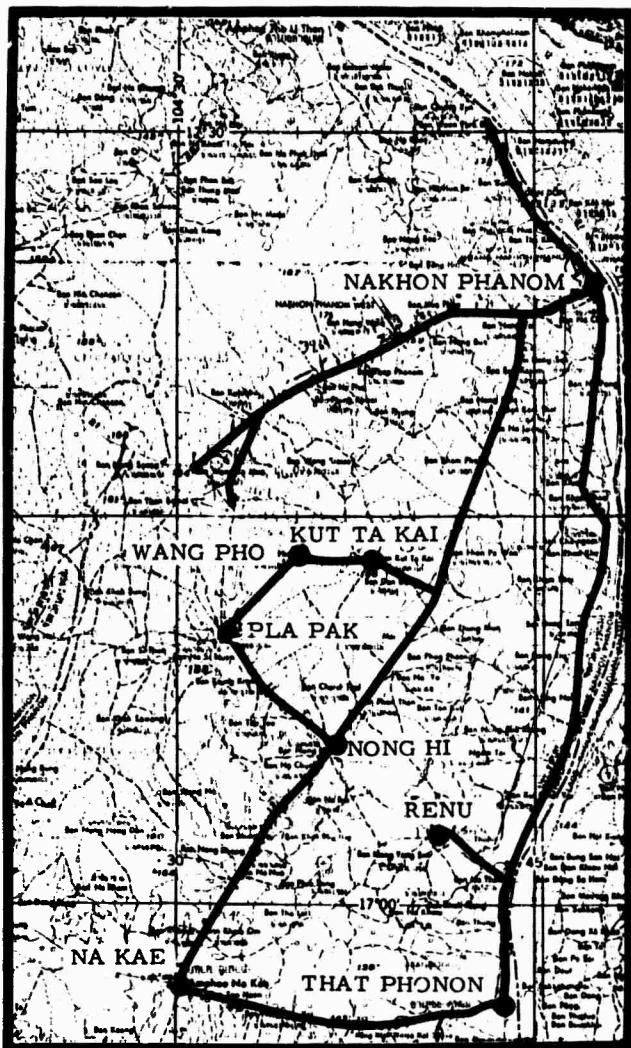

Figure S-5. Sector of Nakhon Phanom Showing Routes Travelled by SAI Study Team.

simulation program identified desirable points for force location. It is suggested that similar velocity maps* could be created by using other representative type vehicles, i. e., typical trucks, buses and motorcycles for the dry and wet weather situations. In lieu of wet weather data, the roads can be rated for these conditions by postulating a degradation in performance. The influence of weather on force effectiveness was reflected in an increase in the required number of force stations to obtain the same coverage as in the dry weather case. This result suggests a possible re-deployment strategy involving defense force for wet

* It is also possible to establish a related cost map which when overlaid could be used to determine relative "cost-effectiveness" data for various networks.

season as compared with dry season allocations. With more definitive data relating to vehicle capability over an existing or postulated network, the planner will be able to examine combinations of road-vehicle conditions and their effect upon force locations. Thus, for a given network and force mobility capability, the effective region of influence of the force for varying road and weather conditions can be established. Similarly, if a rapid deployment of an air (helicopter)-transportable force were required in a given region, the NETSIM program would establish the admissible drop areas and the types of vehicle that should be available at these zones so that the troops could be deployed within a prescribed time interval. Needless to say, a number of force deployment strategies could be exercised in conjunction with the NETSIM simulation program. The existing network could be altered to accommodate a given strategy and these alterations, as previously indicated, could be reconciled with the network postulated for social-economic goals.

FORMULATION OF PLAN

The complete plan for a transportation system involves several stages or phases. The process described in the foregoing discussion was concerned with what could be termed a conceptual phase wherein the rationale and analysis to be employed was developed. During this phase of the program requirements were identified. These include typical criteria associated with social-economic-political and security interactions, technological and engineering factors such as classes of vehicles and types of paths that would be involved in the network; the so-called interface relationships that exist between such elements and the final synthesis of a system that could be simulated to represent a transportation system.

Several examples based on actual conditions observed during site survey were simulated which indicated the utility of the approach. The next phase in such a formulation involves what may be referred to as a design definition phase, wherein a hypothetical transportation system will be designed subject to a number of anticipated requirements. This forms the basis for not only identifying the detailed plans and procedures that will be employed for the complete development plan; but also the identification of areas where research and technology advances could be employed to improve the system; the determination of validation tests that should be performed; and the extent to which additional data must be obtained synthesized and evaluated. Concurrently with this phase and extending into the final phase wherein the total transportation development plan is evolved, is the activity involving pilot programs aimed at tests and evaluation to verify the approaches and options derived during the design definition activity. As a consequence of the previous activity, the final

plan may be assembled which reflects all the requirements necessary to chose a particular system as it could apply to a particular region. This plan will contain all the details needed to arrive at a design for a given region subject to its particular requirements. This includes all those elements

involving the costs, scheduling, engineering complexities associated with the construction of a selected system.

These stages in the formulation of the plan are demonstrated in Figure 6. A more detailed account is contained in the section entitled DATS Program Plan.

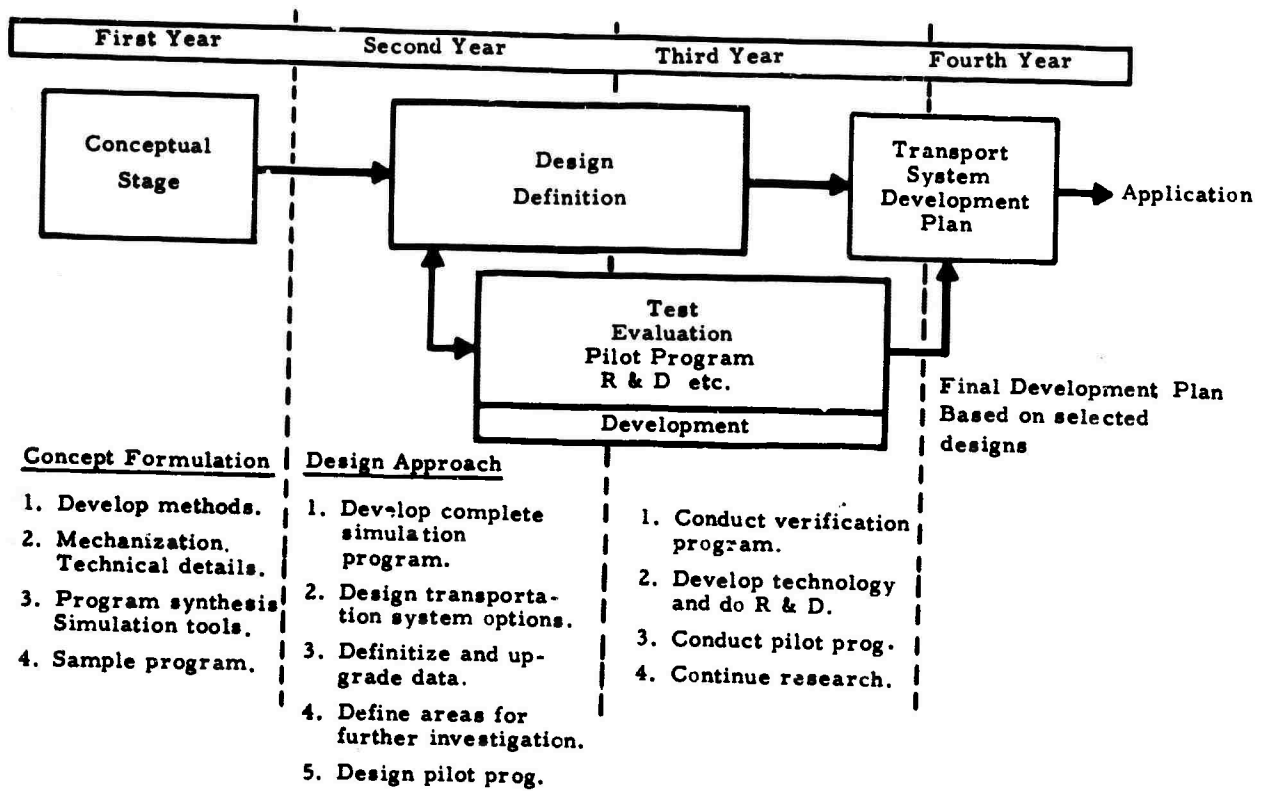

Figure S-6. Flow Diagram for DATS Program Plan

DEVELOPING AREA TRANSPORTATION
SYSTEMS STUDY

II. PROGRAM DESCRIPTION

BLANK PAGE

GENERAL DESCRIPTION

NETWORK

The principal elements of the transportation system are end points or nodes, descriptive of the locales between which a flow of resources is required, and paths which tie together or connect two nodal points. In general, there exist an infinite number of possible paths between any two nodes. For the paths to be useful to a transportation system, there must exist a vehicle, capable of following that path while carrying some payload. A transportation network consists of nodes with their interconnecting useful paths. The network then may be thought of as functionally dependent upon vehicle capability. Thus, an overall system could be described as the set of networks usable by each vehicle. It is convenient to classify transportation networks in terms of the principal mode of transfer between network nodes, such as air transportation networks, water transportation networks and land transportation networks. In any given area, such networks are interconnected at common nodes. In this approach, each network can be analyzed separately and the effects of the other network types are accounted for by suitable boundary conditions at the common nodes.

If each such network is examined in detail, it may be determined that the terrain (air, water, hard clay, etc.) in which the network is imbedded strongly affects the characteristics of a path. A network includes both natural, unimproved paths, constructed highways, roads, bridges, railroadways, sea walls, canals, etc., which can constitute alternate paths between nodes. The particular paths available for use by any vehicle are a function of the vehicle-path interaction. When the vehicle is manned, a more complicated man-vehicle-path functional relationship exists.

ROAD VEHICLE SYSTEM

Description

The paths of the network may include existing roads, trails, waterways, as previously stated. Each of the basic modes - air, water, or land - can be treated separately or in combination depending upon the specific conditions exhibited by the area or region under consideration. The admissible vehicles include all conveyances which can be suitably adapted for transporting cargo or passengers. Such vehicles may be further subdivided and categorized in terms of their ability to negotiate various terrains. In a given region, however, it is desirable to restrict the modes of transportation and vehicles to include only those which exhibit compatibility with the locale and environment which characterize the area under study.

While this phase of the study addresses itself primarily to surface transport modes, the rationale developed encompasses all modes of transportation. For example, the air does provide a medium of transport which appears the least constrained in terms of admissible paths, but presents a situation strongly influenced by termini and nodal point selection. The air paths and acceptable nodal positions (which may or may not coincide with surface nodal positions) in a sense are vehicle dependent because the air transport capability relies on the expected vehicle performance and flying conditions as well as on acceptable termini for landing areas and drop zones. The ensuing transport of resources to and from such terminals or nodal points tends to depend on the surface-oriented transportation wherein these points are inaccessible by air. Hence, the ensuing section is addressed to the road/vehicle combinations and selection criteria.

Criteria

A method for assessing the capability of a vehicle for a given road or path can be devised in which existing vehicles may be categorized in terms of their ability to negotiate a given road situation. This suggests, for a given region, vehicle characteristics that may be tested to determine performance under actual or simulated conditions.

A hierarchy of roads is postulated (as shown in Figure 1) where a category D road represents a particular minimum road class or prevailing conditions in a developing area or region. Progressive improvements of the road or network are indicated by categories C, B, and A, where A is the best quality road to be anticipated for the region. Each of these roads represents a cost associated with their construction and levels of maintenance involved.

Each succeeding step in improvement is indicative of increased usage (need), maintenance and cost. That is, as the area develops, the need for improved roads increases. It is evident that the vehicles which may be employed to negotiate given paths are dependent upon the road condition. Hence, vehicles which are either designed for or exhibit the qualifications needed for negotiating a particular class of roads can be rated in the same sense as the road or path.

Each road class is represented by an associated vehicle class. As successive improvements accrue, an increased number of vehicles and vehicle types become admissible candidates in the road-vehicle system. As the area develops, the road network itself may consist of a mix of roads and paths whose level, as stated, should be indicative of its increased usage. Those vehicles with the ability to traverse the least road in the network are capable of negotiating those roads which are in better condition than the one for which the vehicle was intended. However, it does not necessarily

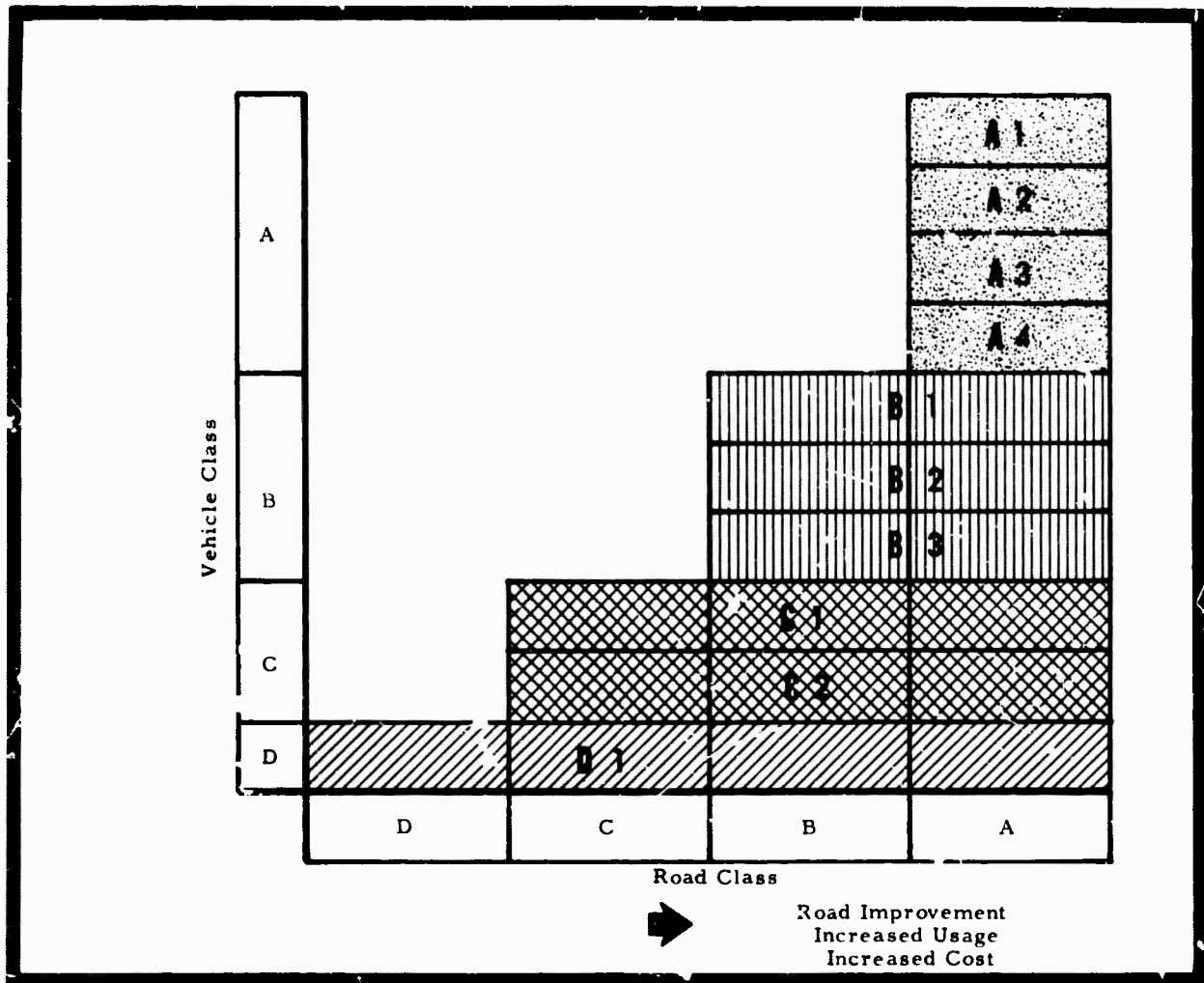

Figure 1. Vehicle-Road Compatibility

follow that vehicles designed for a given set of conditions would be employed on improved roads (e.g., tracked vehicles could damage many roads). Hence, each situation must be evaluated separately to determine which of the admissible vehicle types might be used on various roads of the transportation network. Time-dependent variations in vehicles, such as changing tires (i.e., Terra tires during wet season) should also be considered in this application and planning.

With network improvement, the mix of vehicles retained for the upgraded system could include vehicles of the subsequent subclasses, subject, of course, to specific constraints involving costs and system effectivity. The mix will depend upon the existent need for opening up new areas or for purposes of security where it may be required for a network with all classes of roads to move (off-road) over terrains involving conditions described by D. As stated, this plan will include not only placing values on nodes and usage values on roads, but also to establish a rating system for vehicles.

Data Requirements

To date no completely satisfactory method has been devised to describe the compatibility of a vehicle with the terrain. For present purposes, the standard method of relating VCI (vehicle cone index) to RCI (rating cone index) can be used to establish this vehicle and road compatibility (c.f. Appendices J and K). By establishing the VCI for each vehicle, it may be exercised over the existing network to determine its performance both on and off the road network.

For military purposes or for studying off-road operations in terms of opening new regions, a model can accept various vehicle/road inputs to determine admissible routes for each vehicle relative to a given nodal point on a map. To exercise this system, it is necessary to define the performance to be expected of each vehicle over some range of anticipated conditions. During the site survey by the SAI team, the actual performance of the MRDC radio jeep was recorded over the network of roads in and around the sub-county of Pla Pak in the Nakhon Phanom province and is described in later sections of this report. These road/vehicle capabilities then may be defined and suitably indexed and tabulated.

SYSTEM CRITERIA AND REQUIREMENTS

System Model Requirements

As discussed previously, a transportation system model should be capable of representing and predicting conditions and effects. An objective of the current program is to study the planning and use of transportation systems in developing areas and to determine those factors which allow for social and economic development while ensuring that the military and logistics requirements for security are adequately met. From this objective, the following questions can be derived which the model should be able to answer:

- (1) How well does the existing transportation system satisfy the security needs of the area in question?
- (2) What changes or improvements are required in the transportation vehicle-transportation network combination to improve that ability?
- (3) Which of the combinations will allow for the greatest social and economic development?
- (4) What is the most cost-effective combination which will satisfy the requirements?
- (5) What transportation network will best allow for the development of an undeveloped area?

Additional questions can be posed but the extent of knowledge of the pertinent factors will limit the model. Independent of the social and economic sub-models that can be developed, a prerequisite for answers to such questions is a good model of the transportation system itself.

The procedure followed in the development of a model should allow sufficient flexibility to permit updating whenever new knowledge of either elements or interrelationships is obtained. It should also be capable of answering less complex questions without actively engaging the entire model.

The first point mentioned above has further significance. That is, in developing a model representing a new man-machine system, or a new approach to the representation of an old system, it is often possible to construct detailed models of the dynamic behavior or portions of the system as was done here, but it may not be possible to represent analytically the decision-making processes or the specific criteria used to choose best solutions. Thus, an initial model may consist of: (1) specific subsystems which can provide outputs in response to inputs and (2) separate (from those subsystems) decision making, often done by introducing certain initial criteria.

Usage Factors and Criteria

Typical criteria may be developed which provide a basis for the maintenance, improvement or extension of a given vehicle/road system.

These criteria are related primarily to factors involving the existing and projected usage of the links between specified nodal points or locales. Physical environmental factors as well as costs introduce constraints which influence the type and level of road system or link that may be built and maintained.

Network usage is related to the interaction of the nodal or locale points with one another. That is, the economic as well as social stability of a region may require the maintenance of trade relationships between given sets of nodes. Moreover, there exist certain bonds between locales which are indirectly economic in nature but which contribute to network usage (i.e., religious-political-social). Hence, the nodal or locale characteristics require additional description so that in a cost-effectiveness sense, the value of links between various nodes may be properly ranked and identified. A typical set of criteria identified with the needs of the communities involved may be listed as follows:

Security (Military) Factors

- Link constitutes an element in the police-patrol activity.
- Link important to deployment and maintenance of personnel.

Social Factors

- Link constitutes an element between locales involving the health-education-welfare needs of the region.
- Link provides the basis for communication (postal service).
- Link important to religious and cultural life of region.

Political Factors

- Link provides basis for joining outlying district with governmental centers and agencies.

Economic Factors

- Link provides the basis for the transport of goods/supplies or personnel and for maintaining trade relations (industrial - commercial - marketing centers).
- Link instrumental in opening new areas for development.

The extent to which the requirements of a particular locale are dependent upon these various factors tends to establish the aforementioned usage parameter.

It is possible, therefore, to characterize a locale or nodal point within a region - as (a source or a sink) a producer or a receiver, or both, of resources and services identified under one of the previous categories.

The network provides the means by which these services may be disseminated within any region. The role and frequency at which these resources, services, or personnel may be required to be transferred is a function of the particular need or special situation. Limits on the possible usage rates can be arrived at by examining specific situations.

Where the existing or projected security needs pose requirements which tend to dominate the transport system, it is desirable to consider those options which allow for maximum usable residuals in the wake of such buildups. The road-vehicle system employed for security purposes should provide or fulfill a socioeconomic development requirement as well.

In this light, a rationale has been developed which provides for assigning priorities in a socioeconomic sense to each locality or node, that is, the network that connects localities or nodes would be assessed in terms of its usage for socioeconomic purposes (transfer of resources and people).

Security requirements would enter as factors involving reaction times and could influence the level of road, the kind of maintenance, and the types of vehicles to be employed, and their distribution at nodes involving security force stationing.

When security needs dictate greater mobility (i. e., faster travel times) than the postulated vehicle/road system could supply, then a vehicle change/road improvement plan would be established. This would make necessary a re-evaluation of socioeconomic priorities.

Security - Socioeconomic Requirements

Cost-Effectiveness

The transportation problems associated with developing areas involve the same goals as those of any region. They are: to improve the effectiveness of existing roads and vehicles and to plan future road-vehicle systems in the "best" way. These problems can be treated in a mathematical model by assigning a quantitative meaning to the word "best", which is often translated as "cost-effectiveness", something involving measurements in, for example, tons-miles per unit cost. The concept of minimizing costs for given results remains an important criterion in this program. The introduction of security requirements into the transportation scheme, however, does influence the conventional valuation (costs) scheme. These influences relate to practical rather than to the theoretical difficulties associated with the ability to assign relative values to the socioeconomic and security needs of locales (in network language, nodes). This relative valuation tends to be subjective. The re-

fore, it was useful to design the mathematical program so that the user could at his discretion assign the socioeconomic - military value ratios. The initial tradeoff and value rating problem may be simplified if the program is set up to handle the military and socioeconomic situations separately and then combine the two into a general solution. It should be emphasized that the final analysis must account for the interaction between these elements.

In practice, one or the other spheres of activity may involve such uniform values (note that the transportation system decisions, allocations, scheduling, and so on, are sensitive only to relative needs) that the solutions to general problems involve the mere addition of solutions to specific problems. A somewhat idealized example of this would be a case in which the probability of insurgency in an area is uniform (random outbreaks), and the general transportation solution can be derived by solving for all the socioeconomic needs and then allocating fixed amounts of military supplies and personnel to all locales.

Reaction Time

The tradeoff of security vs. socioeconomic needs as discussed up to now could be viewed as a costing problem, presenting no logically new feature. This may not hold completely for a second effect now to be considered: the introduction into the model of a "reaction time". This reaction time becomes important when the effective action of security forces is dependent upon their arrival at a specified locale within a given time relative to an outbreak of insurgency. It either is useful (arrives within a certain time) or useless (arrives late). This reaction time must be specified as an input by the user, or alternately, derived internally in the program from other inputs (geography, political information, etc.). Of course, the cost-effectiveness formula could be applied to this "time", but it is perhaps more useful to attach an infinite cost to "time" in this case, i. e., to make arrival within the reaction time an absolute requirement. Therefore, the reaction time is taken to define the useful network: only those roads or trails on which one can reach a possible locale within the given reaction time are counted as points of the network in the simulation model. This means that the "network" used in a given solution to the transportation problem depends not only on the physical paths available, but also on the net velocities of the vehicles (on vehicle plus road descriptors) and on the (user-chosen) reaction time.

SYSTEM MODEL FORMULATION

APPROACH

The general approach to the development of a conceptual model to represent the transportation system in any area has been sketched in the previous sections by the discussion of the important factors and interactions and by the requirements and criteria which were developed for the model. This approach can be characterized by the following principal features:

1. The society system model (consisting of social, economic, political, and security spheres) is to be considered as providing (a) those inputs or factors which govern the use and configuration of the vehicle-network subsystem, and (b) the criteria, strategy, and values used for evaluation.
2. The vehicle-network subsystem model is to be considered to consist of the vehicle-transportation network subsystem imbedded in the environment of the area in question, and to be able to (a) accept the inputs provided by the society system, and (b) to provide performance outputs to be evaluated against the established criteria. This subsystem forms a basis or framework for the consideration of a transportation network.

Society Subsystem Inputs and Requirements

As discussed in the preceding section, the society subsystem inputs can, generally speaking, be classified into a common pattern. Given a set of geographical locales, it is potentially possible to list, for each locale, the amount of (1) resources of a particular type (e.g., policemen, food, clothing, etc.) available; and (2) resources of the same type which are needed at that locale. In addition, it is again potentially possible to list the following response requirements for the region:

1. A priority rating of locales for fulfilling needs.
2. Allowable maximum times at each locale for fulfilling needs.
3. Allowable costs.

The society subsystem possesses or generates the strategy, criteria, and values which are used in the evaluation of the performance of a given transportation system. This evaluation leads to

requirements for the modification of (1) the response requirements (as listed above), (2) the resource locations or demands, or (3) the parameters of the vehicle-roadway combination.

In addition, several other aspects of the transportation-network subsystem are controlled by the society subsystem. The existing network configuration, the vehicles available (or potentially available) for use, the levels at which the vehicles and roadways are maintained, are determined by the society. Again, the strategy, criteria, and values of the society are used in this determination.

Physical Environment

The region's climate or weather may exert a modifying influence upon a particular resource availability and demand, as well as upon the vehicle-roadway. For example, some foods may be available only in certain seasons, required security activities may be reduced during the harvest season, etc. The physical environment may strongly affect the structure of the society, and does (obviously) strongly affect the vehicle-network system.

The Vehicle-Network Subsystem

The vehicle-network subsystem contains the vehicle, pathway, and locale elements and their interactions. The vehicles and pathways may form an air, water, or ground transportation network or any combination. Suppose the desire is to establish a model capable of representing each type of network. It is then clear that the characteristics of a land-road network and its compatible vehicles cover the characteristics of all the others. For example, land vehicles exist which are almost unconstrained by the path between two nodes, or by the node location, whereas, some vehicles can only be used on a restricted class of paths, or can only reach certain nodes. Thus, the full range of possibilities is included, and a transportation system capable of representing the surface transportation can, with suitable parameter values, represent the other networks as well. Finally, a composite model that includes each type would represent the total situation.

The inputs to this model and the constraints imposed on it have been outlined previously in the discussions of the physical environment and the society subsystem. The desired outputs of the

vehicle-network system model are performance figures, (e. g., usage, cost, or system deficiencies) for each use (or set of use functions), for a set of vehicles, and for a given roadway configuration. These performance figures are then evaluated in terms of the strategy, criteria, and values established by the society system; as a result, desirable modifications to either the vehicle-network system or to the input functions and requirements are determined.

Model Configuration

The conceptual model configuration resulting from this approach is given by the block diagram of Figure 2. The vehicle-network subsystem is emphasized by the use of heavier lines to indicate the approach characterizing the model. The society system may be represented by several different models which describe one or more of the individual aspects of the society. Each such model, however, would provide a set of inputs and the criteria for a common vehicle-network system. Thus, this system can be used as a basis or framework for the overall transportation system, serving simple and relatively complex society models

alike. Therefore, the initial structure of a model of a transportation system should emphasize the vehicle-network system portion. This procedure has been followed in the study described in this report.

KEY MODEL ELEMENTS

The man-vehicle-terrain-environment relationship is perhaps the most essential element to be defined and characterized in order to establish an adequate model of the vehicle-network system. Indeed, work directed toward defining this relationship has been underway for many years. Terrain has been classified into relatively distinct types, vehicle mobility characterizations have been established, analytical models for the man-vehicle-terrain system have been formulated, and extensive data have been collected on the performance of vehicles on many different types of paths and terrain under many climatic conditions. The transportation system model should utilize as much of this knowledge as possible.

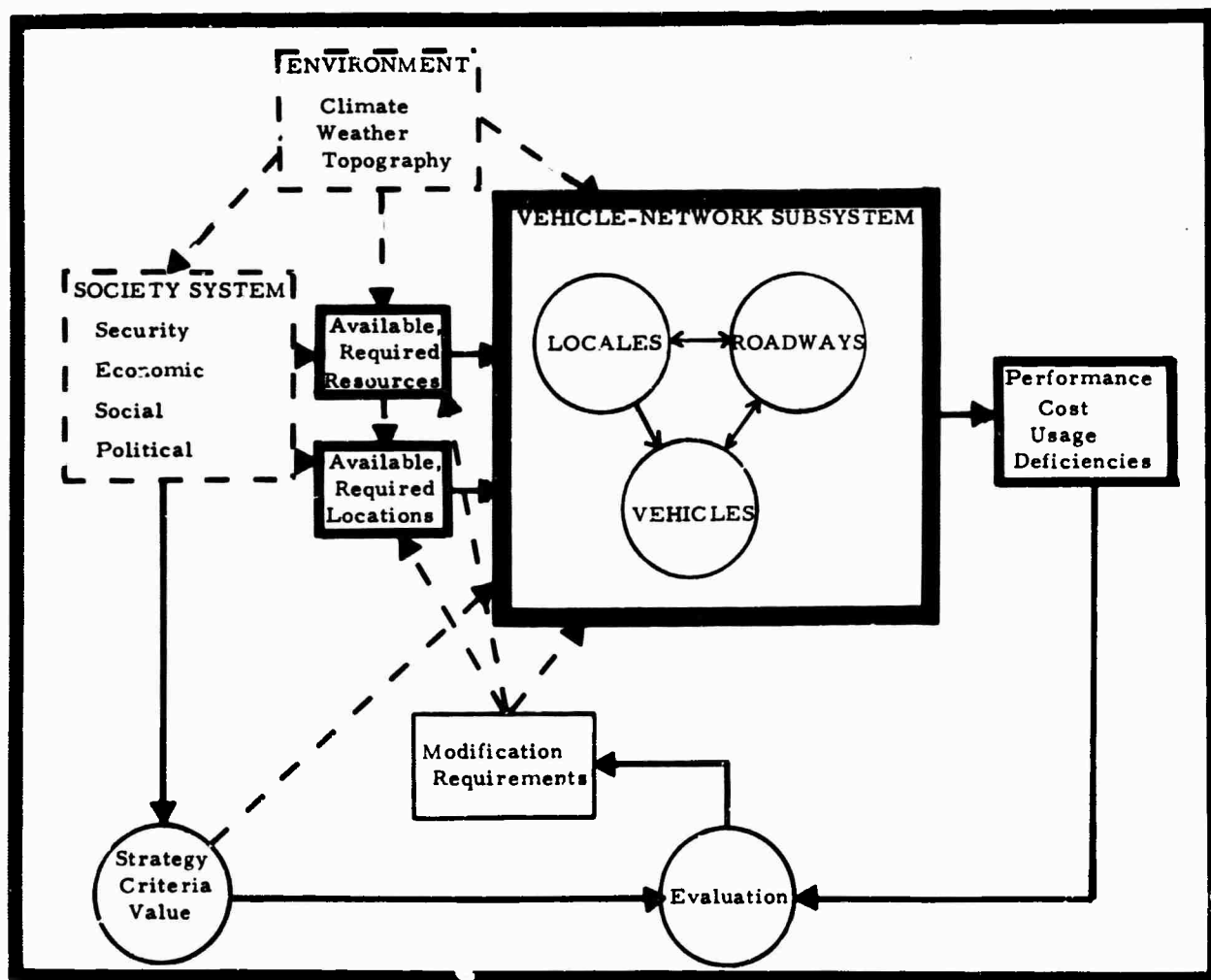

Figure 2. Transportation System Model.

Moreover, interested in relatively broad characterizations of the transportation system. For example, it would be extremely rare that the assessment of a transportation system would require detailed knowledge of the instantaneous vehicle acceleration. It is much more likely that, at most, knowledge is only required of the average vehicle transit time between two nodes as a function of vehicle payload, driver skill, vehicle maintenance level, path maintenance level, season, and time of day.

Thus, there is an apparent choice of representing the total functional interrelationship in a quantified format. Now, vehicles may be considered discrete quantities, and the other variables can be discretized by classifying any particular element as a member of one of a set of disjoint classes. For example, one might consider using several percentile ratings as suitable categories for drivers and passengers; typical climatic and weather categories might be dry season, wet season, heavy rain, windy, etc. Each of these can be particularized for each specific area and path within that area. Typical roadway categories could be concrete highways, dirt trails, swamps, bridges, and fields, i.e., any of the types of roadway or terrain which exist or which are likely to exist in the particular area. Roadway maintenance levels might be categorized as poor, average, or excellent.

Now suppose that the discretized performance level of a vehicle over all possible terrain and roadway types in dry weather is known. Then, if simple modifiers are known for each weather condition, class of driver, etc., the performance should be completely known under all conditions. The modifications required by different weather conditions could be either a fractional change in performance, or could be introduced by modifying the original road type into another road type.

These performance levels can be obtained from one or more of several sources: (1) directly from experimental data, (2) from vehicle-terrain models, such as developed by CAL, or (3) by extrapolation from known performance levels of known vehicles. Some performance levels will be subject to go-no-go situations. For example, if a vehicle is too wide for a trail, then it cannot pass; if a vehicle is too heavy for a bridge, a no-go is indicated; if a stream must be forded, vehicles with the ability to cross the water might be unable to climb the banks; and some drivers will be unable to cross a muddy field, while other drivers using the same vehicle will be able to cross. Since, in the normal situation, the man-vehicle combination is able to traverse the particular path, a test for constraints apart from the basic vehicle-terrain performance is indicated.

Vehicle maintenance and logistics requirements can be handled and categorized in a similar fashion. If the influences of terrain speed

operating time on the fuel consumption and maintenance cycle of the vehicle is known or can be sufficiently accurately estimated, then logistics and maintenance parameters can be established for each path in a network.

THE INCREMENTAL MODEL

The assessment of a vehicle's performance and capability on a transportation network can be accomplished by analyzing first the vehicle performance over segments and then combining the segments into the network. In order to obtain the performance on a segment, it is necessary to divide the links into segment with the terrain type, length, width, maximum grade, and load limit given for each segment. It is also necessary to have generated and tabulated separately the performance of that vehicle on each type of path segment.

These two processes are indicated in Figure 3, where a typical path between nodes A and B has been sketched. This path can be divided into several different types, and a sub-node is shown between each different type of terrain. The descriptor set is indicated by the letter d. Table 1 gives an example of a possible descriptor set for that segment. (See Appendices J and K.) The lower part of Figure 3 represents the process by which the basic vehicle performance is obtained.

Table 1. Incremental Model Sample Descriptor Set

Link	Terrain Type	Length	Width (meters)	Load Limit (tons)	Grade (%)
Aa ₁	12	5 km	3	-	0 ± 3
a ₁ a ₂	32	3 km	3	-	0 ± 5
a ₂ a ₃	61	3 m	-	-	0 ± 3
a ₃ a ₄	38	10 km	4	-	10 ± 20
a ₄ a ₅	17	20 m	6	16	0
a ₅ a ₆	10	10 km	5	-	5 ± 2

Vehicle performance is obtained on each segment of the link from A to B as modified (if at all) by the grade, season, and roadway maintenance level (if the width and load limit tests are passed). The overall performance is the composite of the individual link performances.

Discussion

Thus, the incremental model provides a framework for the utilization of known data and parametric relationships. This data base can readily be updated or modified as dictated by

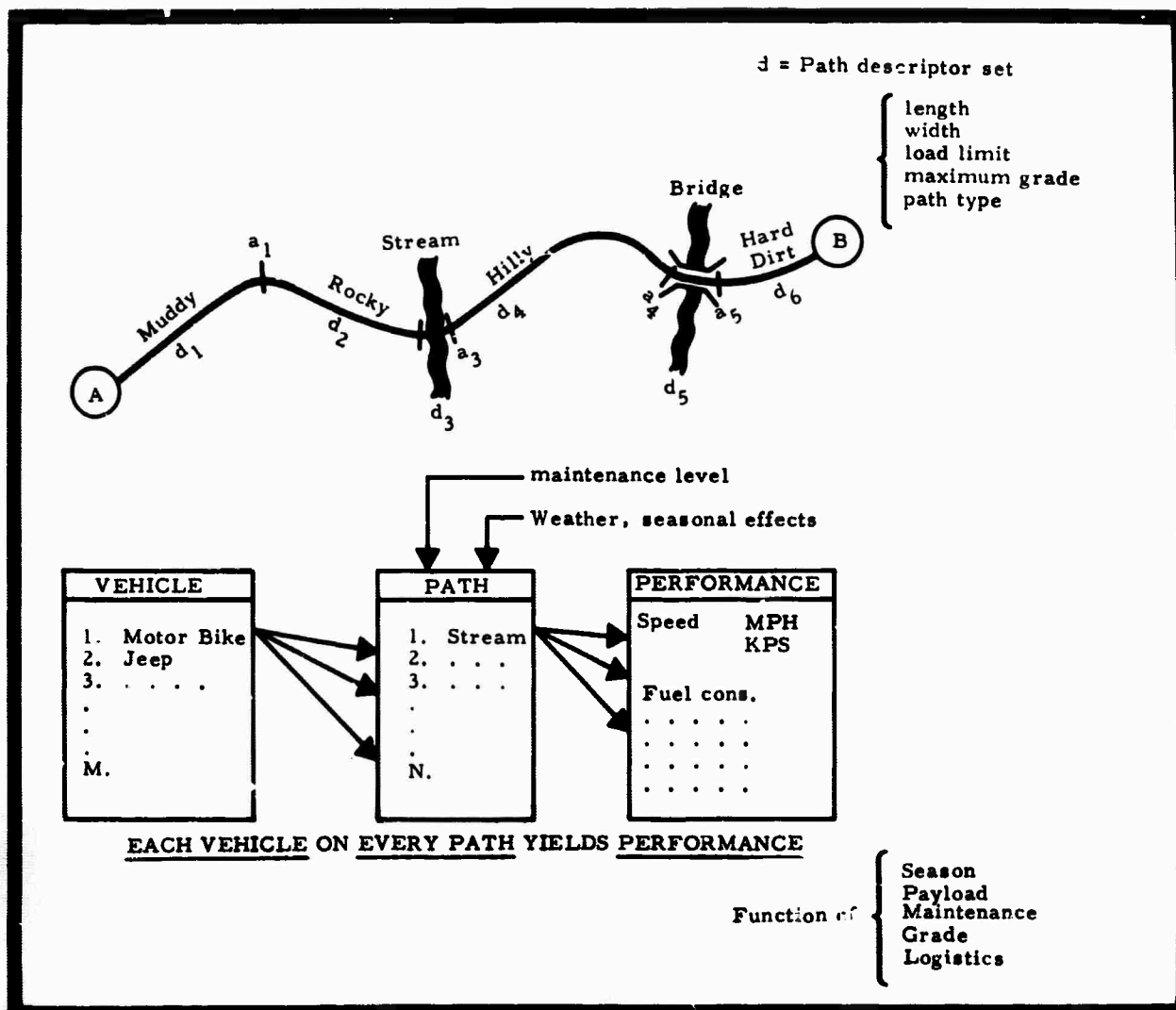

Figure 3. Incremental Model.

experience and increased experimental data. Furthermore, the incremental model can allow for the inclusion of convoy effects, washouts, and bypass choices with the addition of simple logic.

As implied above, the incremental model includes off-road as well as road networks simply by the selection of terrain type for each segment. In both cases, "time-ticks" can readily be computed along each segment and, therefore, along the entire link or network.

Whenever alternate segments or links are possible between nodes, the same procedure can be followed for each possibility and the vehicle performance evaluated in terms of primary and alternate paths.

Note that the incremental model can describe, with a suitable choice of parameters, any type of transportation and any vehicle.

THE SYSTEMS MODEL

Using the incremental model as the essential element and accounting for the interaction between different elements, a variety of transportation system models can be devised. Such models might be optimized for the generation of answers to selected questions that might be asked to meet specific objectives in the synthesis or analysis of transportation systems. Each of these models could serve for pencil and paper computation, but it is to be expected that a simulation program could be designed to perform those computations rapidly with fewer errors. Thus, the model should be configured so that it can easily be realized with a computer simulation.

The objective of this current study was to develop a description of a transportation system model capable of being used to answer a variety of questions which might be posed, as discussed earlier in this report. These questions can be

phrased in terms of resource availabilities at a set of nodes and resource demands at another set of nodes (not necessarily disjoint sets), and in terms of performance requirements (time, cost, etc.) placed upon the vehicle-network subsystem. Thus, it is natural to represent or model this subsystem in the form shown in Figure 4. The subsystem is shown as a set of matrices which, for each vehicle and season, describe the minimum time and minimum cost between every locale pair, together with their associated routes.

This model is built up sequentially as follows: (1) Select a pair of locales; (2) utilize the incremental model discussed previously to evaluate performance on every possible interconnecting path; (3) choose the path(s) providing the best performance; and (4) continue the process for all locale pairs. Then, the paths providing the best performance between any two locales are determined. (The best route may pass through intermediate locales.)

The inputs to this model may, typically, consist of the following:

1. Resource availability at each node.
2. Resource demand at each node.
3. Supply time requirements.
4. Supply cost requirements.

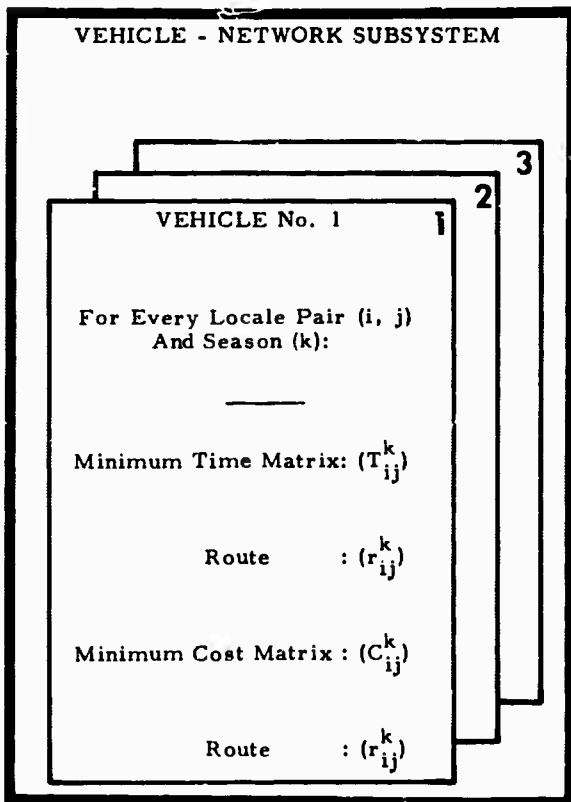

Figure 4. Vehicle-Network Subsystem Model

SIMULATION PROGRAM SUMMARY

The preliminary transportation simulation program formulated to represent the model that has been described in this section will be summarized herein, since the simulation program details are given in Appendix A.

The simulation program is summarized in Figures 5 and 6. Figure 5 summarizes the data initialization and the simulation of the incremental model, and Figure 6 summarizes the program for the determination of regional performance and the resources allocation subprogram.

A significant feature of the program is that both graphical and printed outputs are specified so that the abilities of the transportation system analyst can be fully utilized. Given a specific area to be analyzed, the basic characteristics of the area (existing transportation segments, etc.) can be stored in the computer and used to form a grid or background for subsequent data output plots. For example, time ticks can be plotted on a map indicating the effectiveness zones of each vehicle.

The entry points into the program of the social, economic, political, philosophic, and security factors are varied. The resource requirements at any node represent these factors. In determining optimal resource allocations, these factors influence the resource requirements and a generalized cost function. The philosophic factors are reflected in such items as the maintenance levels of both vehicles and roadways. A requirement for the development of an area is reflected in the resource demands and supplies at each node, as is the interaction with the other forms of transportation.

In summary, as described more fully in Appendices A to D and E, the basic simulation model consists of numerous subprograms for maximum flexibility. This flexibility should be invaluable in the application of the model to the analysis of all developing area transportation systems, since any requirements peculiar to a given area can readily be introduced into the simulation analysis.

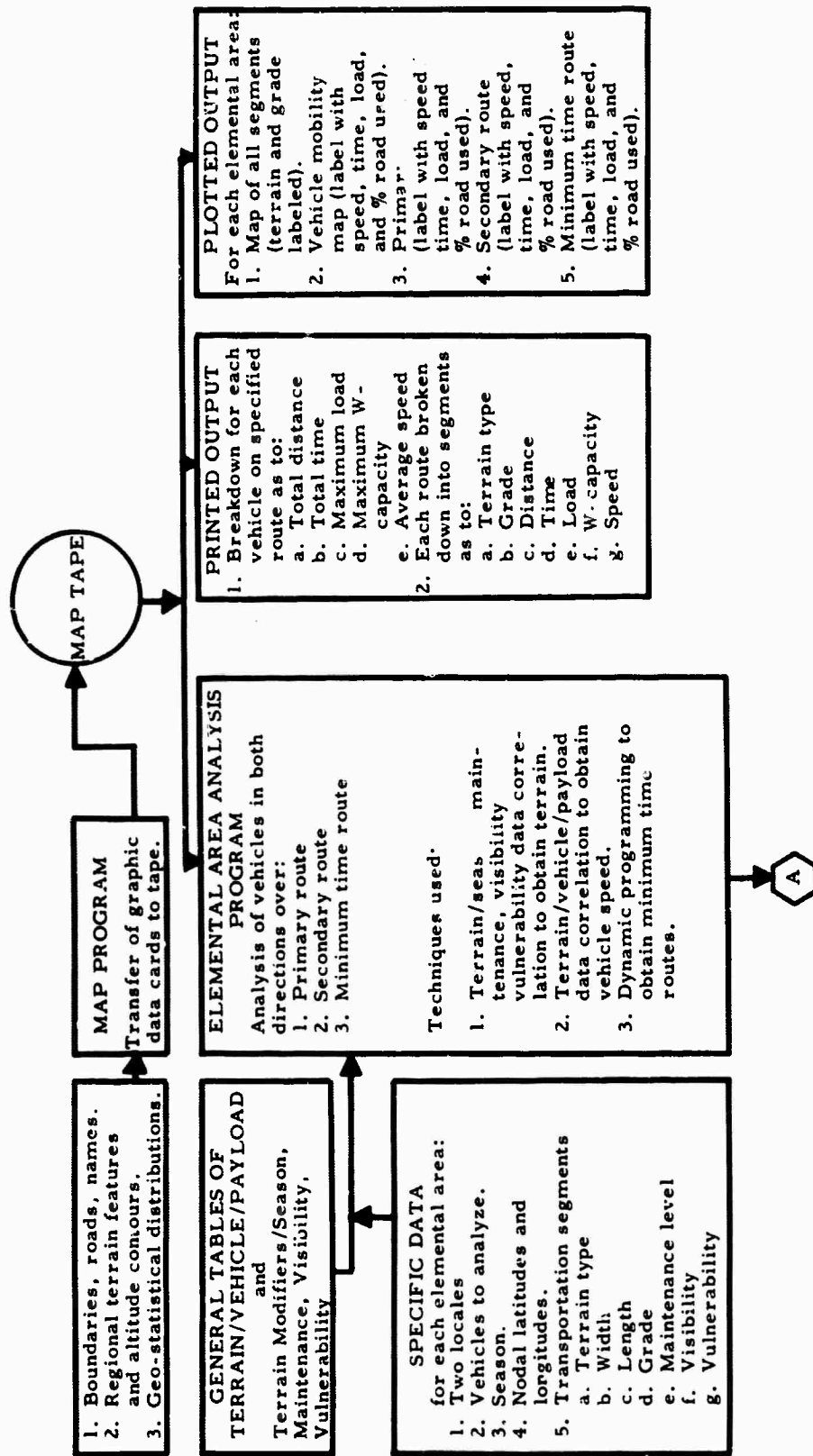

Figure 5. General Flow Diagram: Initialization

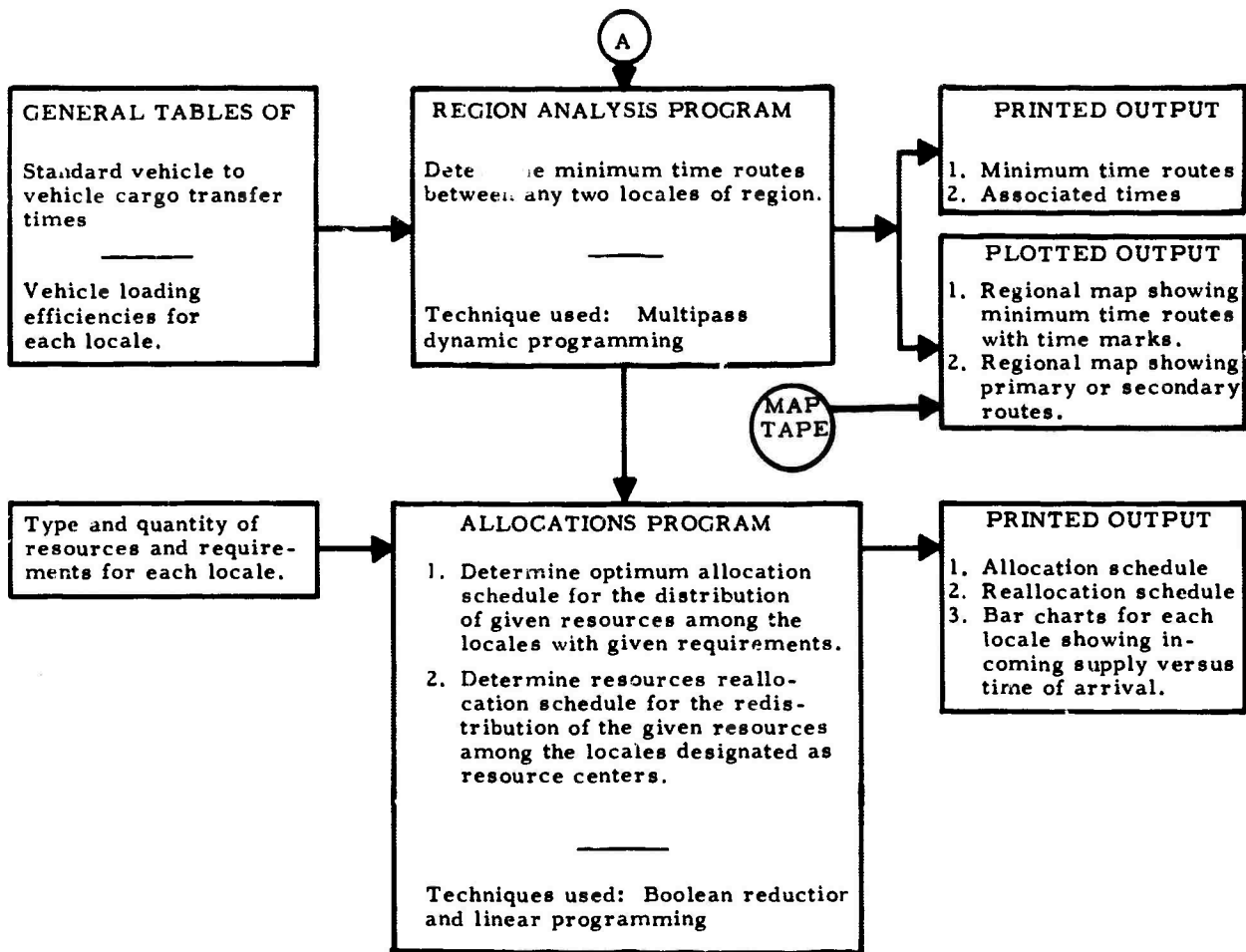

Figure 6. General Flow Diagram: Performance

SYSTEMS APPLICATIONS

SECURITY APPLICATIONS

Characteristic Cases

The SIMDATS program outputs generally provide the data base for answers to questions involving the placement of men and supplies in a developing area transportation network. These relate to the number and placement of units of men and materials at points in an area. Within this general framework, many specific problem areas can be treated; we give below some examples of such problems.

The applicability of the SIMDATS outputs or answers depends on the details of the inputs or questions (inputs) as well as on possible variations in the mathematical program itself (variations in logic). The ensuing discussion deals with how changes in inputs can produce various types of outputs.

In addition to individual input requirements, two types of input information are necessary in virtually all cases, given a physical road-vehicle network. These are:

- A. A reaction time, which defines the allowed (useful) network.
- B. A statement of needs, or requirements for supplying various points on the network.

It is not implied that the applications are confined to situations in which A and/or B are fixed numbers; indeed, many of the interesting cases are those in which A and/or B are systematically varied; nevertheless a definitive number is needed for A and B for each pass of the program. It should be remembered that the program is set up so that needs and reaction times can be derived from politico-geographic information and converted internally to input data using either a counterinsurgency model or a social need model depending on whether security or socioeconomic goals are being considered.

Some applications of the SIMDATS model to military (security) questions in a counterinsurgency context are then

1. Police Force Planning (Low-Level Insurgency Stage) When insurgency is at a low-level stage, a problem of interest may be the placement of police or gendarmerie men and equipment at

the least cost possible consistent with meeting insurgent outbreaks. It is probably of interest to consider this problem for various reaction times, and for various sizes of police units dispatched to the scene of the outbreak. The need model in this case would probably specify that only one outbreak at a time need be met.

2. Counterinsurgency or Army Force Planning (High-Level Insurgency Stage) The program would determine the size and placement of counterinsurgency forces to attain maximum cost effectiveness, in this it would be similar to application 1. However, during high-level insurgency, relatively many outbreaks per month will occur, and the turnaround time of the military forces will be so large that essentially many outbreaks at once would need to be countered.

3. Patrol Scheduling (All Levels of Insurgency) The sizes of patrols and the stationing of patrol personnel would be optimally determined.

The need inputs for the patrol problem would be related to those of the police force problem, but the reaction times would be, in comparison, long.

4. Drop Zones The program could determine the best location for drop zones: time-tick contours would be calculated by the computer and "reachability maps" would be automatically drawn. Inputs would be derived by the user's specifying of locations of interest on a terrain map.

5. Ambush Strategy Gaming and strategy exercises can be carried out using SIMDATS. As an example, we consider an ambush strategy. The presence of security forces, in practice, often provokes, rather than inhibits, the outbreak of insurgency; a typical manifestation of this problem is the ambushing of security forces by insurgents. It is plausible to assume that the insurgents are encouraged to attempt an ambush when they know the size of security garrisons; a naive optimal allocation solution may then not be desirable strategy for the counterinsurgent forces. The SIMDATS program, however, can

be used without special inputs to generate a group of near-optimal cost-effective solutions, and then this group can be used for strategic purposes. As an example, solutions in this group could be alternated in time, so that large garrisons in a random fashion, thus giving as little information as possible to the insurgents, while still keeping costs as low as possible. In effect, the program tells how to buy surprise at the cheapest price.

6. Deployment The use of rather complicated deployment patterns has been considered as an answer to the problem of identification and destruction of insurgent forces. Desired deployment patterns can be entered into the SIMDATS program, which treats them without difficulty as just a new addition to an existing network. The program can specify where the physical location of the pattern sub-nodes should be, given the desired pattern shape and required reaction times.
7. Construction of Roads (Security Orientation) Given the physical location and/or the strategic evaluation of present off-road points, the SIMDATS program can recommend where new roads should be built and what kind of roads they should be.
8. Selection of Military Vehicles The usable network in the SIMDATS model is a function of the reaction time (pre-scribed) and the parameters of the vehicles and roads. By comparing the cost of allocating security forces in these usable networks (different for every mix of vehicles and roads), the program user can see at a glance which vehicle would be most cost-effective for his purposes. All costs, including of course those of vehicle purchase and maintenance, are included in the answer.

Requirements in Insurgency Phases

The mathematical simulation model SIMDATS can be applied to optimize placement of security forces in counterinsurgency situations. The inputs to the program can be specified to correspond to projected location and frequency of insurgent incidents, the nature of roads and terrain, and the maximum allowable delay (reaction time) in meeting outbreaks of insurgency. The program outputs give the optimal allocation of forces for fixed inputs, and can be used to conduct strategy games and to plan new transportation links when the inputs are varied to correspond to new situations. In addition, input parameters can be varied to represent statistical or other uncertainties in the

available data, so that one can generate a group of outputs giving possible solutions to the problem which are consistent with basic uncertainties in information.

Some of the input parameters relating to insurgency frequency and location are considered here as they relate to low-, medium-, and high-level phases insurgency.

Low-Level Insurgency Phase

In the low-level phase, insurgents act as individuals and in very small groups. Counter-insurgency action would usually involve the dispatching of police forces to the scene of propaganda activities or harassment of local government officials. An appropriate task for the mathematical simulation model here is the allocation of police and gendarmerie stations in such a way that security forces can be sent to any point in the area within a given reaction time. A reaction time, say, somewhat less than 6 hours, would be required if the police are to apprehend the small groups of insurgents operating in this stage. The mathematical problem here is similar to that posed by a minimum-cost fire department program, in which station and firemen are placed in optimal (most cost-efficient) locations.

The parameters involved in making a detailed model calculation for, say, Northeast Thailand, would include the rates of men on foot and vehicles on roads over various terrains. The terrains and road conditions would require data from various surveys. Off-road and poor-road parameters can be derived from data such as the MRDC "Mudlark" and the Battelle Study (RACIC-TR-59) provides as well as from other pertinent field tests.

The considerations above are adequate if the insurgent incidents occur randomly; in general, however, the locations of incidents may cluster for political, economic or geographical reasons. Political factors may be assigned which involve the origin of the insurgent type as a "focal-points-of-insurgency" condition, and then by use of terrain-dependence data from other situations and experience the likely foci of insurgent activity may be found.

For example, since the flat lands are usually more densely populated than the others, the total number of incidents in flat country (ricelands, swamps) will be large, in the low-level phase, and more police should be stationed within reach of these areas. The importance of flat country surveillance may also influence the choice of vehicle or the priorities of road improvement; such decision can be arrived at by analyzing appropriate program outputs.

The dispatching of police forces is one aspect of the problem in the low-level phase of

insurgency; another is that of determining the location and strengths of regular patrols.

The simulation program handles this internally as a "steady state" case, in contrast to the "transient" dispatch case, but the input-output situation is no different: patrol requirements are fed in, and recommended force sizes and locations are read out.

Medium-Level Insurgency Phase

In the medium-level phase the insurgents commonly operate in small groups (less than, say, 15 men). Police action, as indicated for the low-level phase, will still be necessary, but in addition, troops in platoon (or perhaps company) strength may have to be sent to counter the insurgent threat. These larger bodies of men will inevitably require a somewhat larger turn-around time so that reaction times may have to be adjusted from the low-level values. Indeed, several reaction times may be involved, depending on the size of the insurgent force involved, and on whether major (ambush, atrocity, etc.) or minor (harassment, propaganda, etc.) incidents are involved.

The road-vehicle parameters are collected as in the low-level phase, and the probability of simultaneous incidents is likely to be still somewhat low, so that the "transient response" (Quick reaction to only one place at a time) is probably most apt here. The terrain-politics dependency again must take note that of various terrain types and the incidence of insurgency for each type. That is, the relative probability of incidents for this insurgency level can differ from those observed for the lower insurgency level. Relevant input parameters would have to be changed, accordingly, for this stage.

A new feature arising in the medium-level stage is that of ambushes. Ambushes may be provoked by the presence of police or soldiers, and so one must play a game with the program outputs - a possibility mentioned in the introduction - to determine the optimal location of forces. An example of a simple possible solution is that if an ambush is provoked because the insurgents know the strength of a police contingent at a given location, then a rotation of contingent strengths may discourage ambushes.

This rotation could be accomplished by using a variety of (ordinarily) near-optimal solutions to the allocation problem, switching from one solution to the other at random intervals.

High-Level Insurgency Phase

In the high-level insurgency phase, the level of incidents has grown to the point where a "steady state" (continuous counterinsurgency operations) solution is required. The distribution of forces by terrain would be similar to that in the medium-

level case; but the total number of incidents is high, and the size of insurgent force units may grow to company, or even battalion strength. Large counterinsurgent forces (acting now sometimes in battalion strength) will be necessary, and since the turnaround time for battalion-sized operations is large the flow of men back and forth may be quite steady. In addition to these new personnel requirements, the minor incidents go on as before, indicating the need for continued police and patrol type solutions in the new environment.

Vehicle and road parameters may be different in this stage corresponding to degeneration of roads in conditions of greater use, and the operation of larger forces off-road. Off-road operations can be treated as new network inputs, and best solutions could be obtained for the placement of troops or patrols so that they could reach the perimeter of some circle around a given point within a given time.

In this last connection, the concept of deployment can be handled in the form of a new sub-network input, so that the details of relatively large operations can be analyzed in terms of the terrain and of available men and vehicles.

SOCIOECONOMIC APPLICATIONS

Characteristic Cases

Although the current socioeconomic needs of a developing area can be determined, in principle, in practice data on the goods and services requiring transport between nodes of the network may be unavailable. Hence, for developing areas, representative situations must be postulated. In addition, wherever the existing network and vehicles need modification in order to satisfy newly defined situations, it becomes necessary to extrapolate current data (if they exist) in order to define the potential usage of the system. As a substitute for direct measurement of needs, a need criterion often employed is the actual usage, (e. g. ton-miles of cargo/year). Such usage measurements, although meager for developing areas, may be used as available to assist in the shaping of models and in the scaling of the relative needs of locales in the network. (Note, potential usage patterns may not necessarily duplicate the actual usage but serve as a guide for establishing transport requirements). It is desirable, though, to construct some reasonable need pattern from available social and economic statistics so that a basis for evaluation of transportation requirements can be made in quantitative terms.

In this vein a rationale for defining a transport system to meet the needs of a given region is delineated broadly in terms of requirements involving nodes-roads-modes (shown in Figure 7) and defined as follow

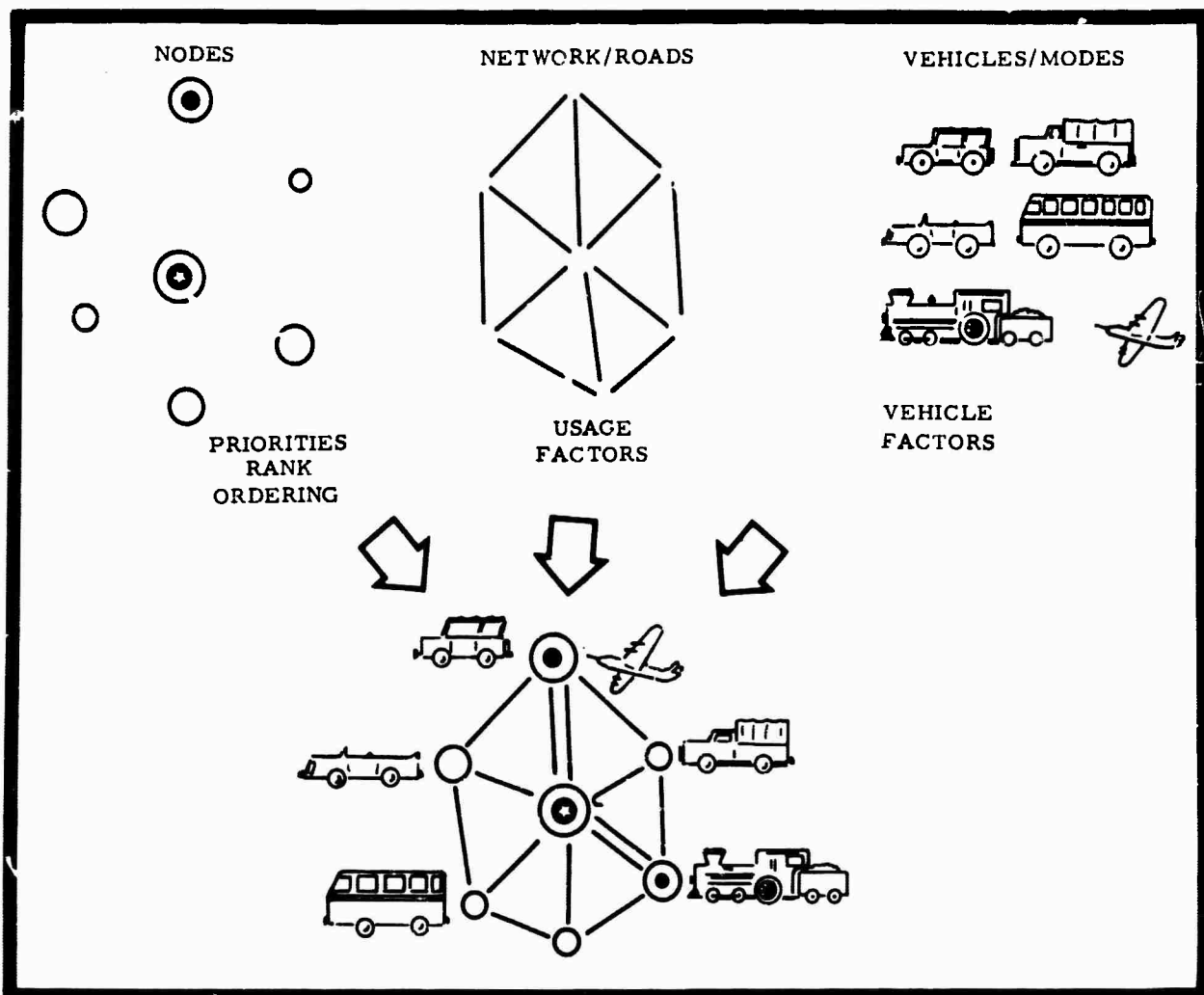

Figure 7. Transportation System Elements and Synthesis

1. Establish a rank ordering of nodes by assigning values to locales on the basis of their relative importance in terms of:
 - a. Population
 - b. Economic development (agriculture-industry, etc.)
 - c. Strategic location
 - d. Political status
 - e. Social cultural-religious values
 - f. Projected regional growth
 - g. Prestige factors.
2. A network is then devised which links the various nodal points wherein the anticipated usage is identified between nodal points of the region. The usage values assigned the links relate to the

characteristic interaction and dependency that exists between these nodes. Example - Rice Mill at "A" and agricultural center at "B". Rice must be transported to A at regular intervals and transferred back to B as primary food for population. The usage factor is related to ton-miles of cargo to be transferred between nodes. In a similar manner, a link, real or hypothetical, could be evaluated. The usage factor in general helps to define the relative importance of road to the region - in terms of category and rank ordering. Such a rank ordering identifies the priority by which such roads may be provided and the level at which they should be maintained.

3. This step involves the nature of the carriers, or vehicles. The selection of the vehicles will depend upon the rates, frequency and quantities of resources to be transported as well as on the type of

paths that it may be required to traverse within the region. While the vehicle road dependency does impose constraints, it is possible to identify classes of admissible vehicles and vehicle modes to fulfill the major requirements. In a developing region in general, the vehicle selection is directly geared to the road level and its projected utilization.

Economic Factors

Economic factors are divided arbitrarily below into production and distribution, utilities and communications. A few specific examples of these factors, based on northeastern Thailand communities, particularly in Changwat Nakhon Phanom, are described.

Production and Distribution. Examples of factors involving economic services in Changwat Nakhon Phanom are rice mills, kenaf (fiber) binders, salt wells, sawmills, sand and gravel workings, general stores, important market places, and so on. (In assigning quantitative values to such factors as rice mills and kenaf binders, we must take into account the seasonal variation of usage: a rice mill may be represented by one value during the November-January harvest season, and another during other times of the year.)

Utilities. In this category fall dams, electric power stations, water pumps, irrigation water supply tanks, and so on. We can use, for example, (kilometer)² of irrigated land supplied to give relative value to two dams, and "megawatts generated" to assign value to two different electric power stations.

Communications. Communications include post offices, printing plants, radio stations, telegraph offices, etc. If all forms of transportation are included in a given network, then all transport facilities are (implicitly) network variables, not considered in this section; but if, say, a road system only is considered, then airports, harbors, and railway stations must be considered here as representing node priorities or needs.

Social Factors

Social factors include the health and well being, religious and cultural values, and the education of the community.

Medicine. Trained personnel, such as physicians, dentists, nurses, pharmacists, health workers, midwives, etc., can be assigned values corresponding, for example, to the inferred number of visits made to or by the trained person per month per thousand people; or, lacking such data, the relative value of the training to the populace in a given locale can be assessed semi-intuitively.

A similar evaluation may be made for the need and utilization of facilities, such as hospitals and public health centers.

Education. Elementary, secondary, and vocational schools plus nursery schools and kindergartens can be assigned values in accord with some formula balancing size of school body against level of education. The determination of the parameters of the formula can be facilitated by the observed usage in countries where more data is available.

Religion. Priests, temples, and other appurtenances of religion can also be evaluated, keeping in mind that priests in small villages perform many quasi-medical (clinical-psychological) and quasi-economic (loan-counseling) services.

Recreation. Cinemas and other entertainment places can be counted on to require certain amounts of transport, thus forming a local need. Sites of major festivals precipitate a need for increased transportation during the celebrations. It should be noted that Central American experience shows that improvement in transportation contributes markedly to increased attendance at major festivals, while minor festivals may decline in popularity.

General Factors

Other salient factors which differ from those previously described are associated with the government and the population distribution -- these tend to overshadow and provide a general indicator and gross measurement of all socioeconomic factors.

Government. In northeast Thailand, government functions can be roughly taken into account by giving numerical values to changwat (provincial), amphoe (country) and tribon (district) capitals. That is, a town having relatively small economic value compared to another in the same amphoe may yet have to be assigned a relatively large priority in making up a transportation network.

Population. As mentioned above, the factors associated with population can provide a separate set of priorities, since, in a sense, it is a measure of all socioeconomic factors. Population size could provide an independent check on the assignment of economic values. That is, locales involving relatively large concentrations of population also exhibit a proportionately greater need. During the development of the ECON-ILP model, discussed in a later section, it was discovered that population figures may be the best kind of data to use, because of both their relatively greater availability and their unambiguous nature.

Modifications under Conditions of Insurgency

It is difficult enough to set values on both socioeconomic needs and security requirements when planning a model transportation system; the problem of the relative valuation of the areas is indeed complex. The SIMDATS program, as already mentioned, does allow the user to determine his own relative value ratios, as part of an effort to give the program the maximum flexibility. Nevertheless, it is interesting to consider the valuation problem as encountered in actual environments, both to aid the user who is interested in examining various relative valuations, and to provide the framework to a "shorthand guide" for the user who is relatively uninterested in rather exact transportation solutions. That is, the user should be able to, so to speak, press a button marked "Low-Level Insurgency", and get out a transportation solution which incorporates plausible value ratios between military and socioeconomic needs.

Considered here are peacetime or low-level insurgency, high-level insurgency, and de-escalation situations. The socioeconomic conditions corresponding to these security area categories are supposed to be those typical of a developing area (per capita income under \$50, say).

Peacetime or Low-Level Insurgency Conditions

It is probably realistic to treat these two conditions together, since the stresses of life in developing areas make readiness for insurgency a necessity even under what appears to be prevailing peaceful conditions. Furthermore, there may be little need, when designing a transportation network to give a tremendous security bias to such things as choices of routes. Such a simplifying situation will occur when a pattern of "random insurgency" is either present (in a low-level insurgency case), or posited (in a peacetime case); if insurgency is apt to happen anywhere, then one can go ahead and plan routes to satisfy socioeconomic needs, just adding in security tonnage requirement proportionally. Even in this (mathematically) easy case, however, what is true of routes may not be true of vehicles: security countermeasures may require special vehicles for off-road travel, for example. Considerations of total cost effectiveness may then indicate that less money should be spent on road repair (to compensate for the purchase of relatively expensive vehicles) than one would spend, ordinarily, from just socioeconomic considerations.

If a skewed (non-random) pattern of insurgency either exists, or is anticipated for the future, then one may have to be able to move a large number of police to points in province "A" but few or none to points in province "B", and the considerations above do not hold. One may wish to design a network solely for police purposes first, ignoring the socioeconomic factors entirely, and then, using that as a base, add in the socioeconomic

needs as a guide to further vehicle-network improvement. On the other hand, a simple compromise solution might be desirable, especially since socioeconomic deficiencies are presumably a causitive agent for political unrest. That is, military tonnage and socioeconomic tonnage could be treated on a par, and the overall transportation network designed to get the best of this compromise tonnage for the number of dollars spent.

High Level Insurgency

Under high-level insurgency conditions, the same considerations of insurgency pattern hold in principal; that is, more socioeconomic usefulness can be expected a priori from road improvements and vehicle changes made in many areas of the country rather than just in special locales. However, troop movements in this stage may be rather large, and the purchase of large or specialized, relatively costly vehicles may be of first priority. In addition the large volume of military traffic may require greatly improved roads. If greatly improved roads are required by an optimum civilian solution, then there is no value conflict; but other types of civilian solutions (good vehicles, poor roads; seasonal improvements for harvest only; etc.) would not then be acceptable. The transportation problem for random high level insurgency could then be looked upon as a basically pure "socioeconomic solution" (because of the equality of military and socioeconomic node priorities) in which the military requirements act as special constraints, instructing us to discard some out of the set of solutions produced.

When the insurgency is markedly non-random, the situation here is similar to that in the low-level case: one wants pure military solutions with socioeconomic needs added later, if money is available. Compromise solutions would presumably be less desirable because of the heightened danger to the whole social fabric of the insurgent threat.

De-escalation

In de-escalation, or the withdrawal of troops in going from a war or high-level insurgency condition to lower levels of military activity, the value of socioeconomic needs becomes large relative to the priorities. Indeed, a transportation system suitable for lower-level security activity is presumably already existent, or can be provided relatively cheaply. The pattern of the socioeconomic needs may be changed, however, by unfamiliar factors, so that the design of the network may differ sharply from the peacetime case. For example, military vehicles too expensive for civilian use may be left behind, or the level of road- and vehicle-maintenance capability may fall sharply. In addition, centers of civilian population dependent on military expenditures for economic viability may have been established, so that the needs of the transportation system might have to be determined not by such indicators as present population and economic activity, but by rather

complex projections into the future. The socio-economic system, in sum, may be inherently unstable, in contrast to the static tendencies usually present, and great care must be taken in devising transportation requirements.

SECURITY - SOCIOECONOMIC MODEL SYNTHESIS

The previous discussions of the program applications have implicitly contained the assumption that a composite evaluation of the performance of a given transportation system would be performed by

- (1) Evaluating the performance of the transportation system for each specific situation.
- (2) Developing the composite rating by a simple function including all situations.

For example, the usage (in, perhaps, ton-miles/year or trips/year of any transportation system route might be given simply by the sum of individual use factors for each situation, modified perhaps by appropriate constants to reflect relative importance.

However, it may sometimes be of interest to be able to perform an initial (rapid) system evaluation which does not require the separate consideration of each type of network use. In this case, it may be possible to construct composite functions to represent the total composite resource and total composite demand at any locale. Thus, it is of interest to assess the possibilities of whether the program, if necessary, can calculate such requirements by applying a somewhat less precise formula to politico-geographic information. (We do not discuss the vehicle-road parameters, here, but it may be noted that road-vehicle maintenance and fuel depot costs can be absorbed into locale needs.)

Military Inputs

Let the nodes (locales) on the network be labeled with the index

$$i = 1, 2, \dots, n_i$$

then we can write the military (security) needs M_i , measured, for example in tons/month, in terms of numbers representing such need factors as

- X_i , population in the region of node i ,
- Y_i , political origins or biases of insurgency near node i ,
- Z_i , terrain near node i ,

and so on, where the units used are arbitrary in each case. Then we need dimensioning coefficients

$$a_X, a_Y, \dots$$

which relate the different needs to tons/month, so that, finally, we have

$$M_i = a_X X_i + a_Y Y_i + a_Z Z_i + \dots$$

where the dots indicate that other factors have to be added, in general.

Note that the a_X , a_Y , etc. will depend on the "time" t , (level of insurgency)

$$a_X = a_X(t), \text{ etc.}$$

since the needs M_i change as time goes on; however, they involve a universal value choice, so that the a_X 's do not depend on i , the node point indicator. Naturally their "universality" only represents a convenient splitting-up of the functions of the a_X and the X_i . In addition, the essential linearity of the expression for M_i represents an assumption which is not essential to the program but which is simple and reasonable a priori.

As an example, if we believe that the Amphoe Muang Nakhon Phanom ($i=1$) is likely to have twice as many incidents at a given insurgency level as the Amphoe Mukdahan ($i=2$) then we have

$$\frac{Y_1}{Y_2} = 2.$$

Further, the terrain factors are both the same (flat),

$$\frac{Z_1}{Z_2} = 1,$$

and the population ratio (1963) is

$$\frac{X_1}{X_2} = \frac{79,401}{76,817}.$$

Then we can write the needs as,

A. M. Nakhon Phanom: ($i=1$)

$$M_1 = a_X (79,401) + a_Y (2) + a_Z (1) + \dots$$

A. Mukdahan ($i=2$)

$$M_2 = a_X (76,817) + a_Y (1) + a_Z (1) + \dots$$

where the problem of making reasonable determinations of the absolute values of the a_X , a_Y , etc. to get M_1 and M_2 in, say, tons/month, is not treated here. Note that this formulation, however, makes

necessary changes to the a_x, a_y, a_z, \dots relatively simple to carry out.

Socioeconomic Inputs

The socioeconomic needs can be treated similarly to the military situation, again using a formula which is adopted, lacking any other information, in order to try to organize the data in a way consistent without intuitive evaluations. An example would be

$$S_i = b_x x_i + b_y y_i + b_z z_i \dots$$

where the nodes are again labeled by $i = 1, \dots, n_i$. S_i is the total socioeconomic need (tons/month), the x, y, z represent needs (data) and the a_x, a_y, a_z are the coefficients converting data from various units into tons/month.

Here we could take the x_i to correspond to population, the y_i to the number of people employed in rice mills, say, and give z_i the value 1 for an administrative (amphoe) capital and the value 0 otherwise. This of course is only a partial list of the needs mentioned previously. Then (1963) data gives for two tambons in Amphoe Ban Phaeng (Changwat Nakhon Phanom), which we label

$i = 3$, A. Ban Phaeng (capital)

$i = 4$, Na Thom.

the following socioeconomic needs:

$$S_3 = b_x (6,878) + b_y (15) + b_z (1) + \dots$$

$$S_4 = b_x (4,523) + b_y (5) + b_z (0) + \dots$$

in tons/month, where again the b_x, b_y, b_z are not yet evaluated, but it is evident that a comparison of several trial S_i will aid in assigning them values.

Combined Systems Inputs

The values of S_i and M_i can then be combined in the form

$$T_i = AM_i + BS_i$$

where T_i is the total need, military plus socioeconomic, and A and B must be determined externally, but should have the same values for all i if the M_i and S_i are calculated correctly. The total resources available could be characterized in a similar fashion. The SIMDATS program would then provide the preliminary system evaluation sought.

CASE STUDY: NORTHEAST THAILAND

FIELD SURVEY - SAMPLE REGION

The approach described in this report involves the development of tools and techniques that are used in the formulation of a total systems plan. As alluded to in prior sections, one such element is the development of a total simulation program, SIMDATS. To demonstrate the validity of the approach, it was desirable to exercise certain elements of this diagram for a specific case. It was recognized that the data required in many cases was either non-existent or in a form not readily usable. Therefore, it was both useful and instructive to select a particular underdeveloped region and visit it to collect actual data, however limited, to inject a dimension of realism into the validation process. Furthermore, in order to develop the insight necessary for shaping future programs, only on-site observations would provide the opportunity to determine what types and forms of data were obtainable.

The sample region, so selected, should reside in an area that could reasonably be described as a developing area. In order to shape the scope of the simulation program it was decided that the region should be adjacent to a main artery to provide a network link for inter-regional transportation. This area should, in addition, represent a situation involving specific security requirements. The intent here was:

- (1) to study the existing transportation network, if it existed, and to describe it in terms usable in the simulation model;
- (2) to obtain representative data as inputs for the incremental model description, i. e., bridges, streams, terrain conditions; and
- (3) to gain insight into the local socio-economic and security environment.

The representative area selected was in the province of Nakhon Phanom in northeast Thailand. This region is shown in the accompanying map Fig. 8, and includes the area north of route 223 (all-weather, two-way, laterite road) and is located generally between the Changwat border on the west and the Mekong River on the east. It, in fact, involves parts of Amphoe Na Kae, Amphoe That Phanom, and King Amphoe Pla Pak. It will be observed later in this section that a region in the vicinity of Pla Pak and Nong Hi was used in the sample calculations. Some of the existing and "projected" elements in the network were simulated and the actual performance of the MRDC radio jeep, used for the ground survey, provided the basis for the velocity data used in those models.

The choice of this representative area was a convenient one since a recent survey in depth,

covering particularly the social, economic, and political spheres, of Changwat Nakhon Phanom has just been completed.* Thus, the data gathering survey was not required to be as extensive as it otherwise might have had to be. The data gathering in the areas described by the handbook could be limited to obtaining answers to questions which arose in the study of the handbook.

The data gathering survey in the area described took place in December, 1967, during the dry season in Thailand. The region between routes 22 in the north and 223 in the south was examined from the air. Road systems presently under construction were observed. The north-south road 2033 from Na Kae through Nong Hi and planned to reach route 22 was in various stages of construction under the aegis of the Highway Department. Several other arteries in and around Pla Pak were observed.

Subsequently, roads, cart tracks, and paths were driven over in several areas: a section north of Nakhon Phanom, a portion of a cart track from route 22 toward Pla Pak, and the selected representative region. The vehicle employed over the road network was an MRDC radio jeep carrying four passengers: Major Farmer and Major Nori of the joint Thai-U. S. Military Research and Development Center and Dr. Lampert and Dr. Walli of the SAI team.

The roads traversed (as indicated on the map of Figure 8) were rated as to average speed of the jeep over the various links. Such data are typical of those required for the simulation program. These routes consist of two-way laterite all-weather roads, dry season service roads (also known as pioneer roads), and unpaved stretches of ox-cart trails. In general, it was possible to traverse laterite roads at an average speed of forty miles per hour while sundry paddy land and jungle trails could be traveled at five to ten miles per hour. Buses and trucks were observed traveling the two-way principal all-weather routes in the area (22, 212, and 223) at speeds comparable to the jeep speed.

It was observed that the fine silt raised from the cart tracks and the laterite surfaced roads might pose problems in vehicular maintenance and operation. The radio jeep, for example, experienced degraded braking performance several times because of the silt and dust.

Representative examples (in summary form) of road/vehicle network data collected in the field survey are given in Table 2. Very few motor vehicles were observed during the field trip in the test area, as indicated in the table. Apparently, no motor vehicle garages or service stations were

*Provincial Handbook - Changwat Nakhon Phanom - Thailand, 6 vols., prepared by Philco-Ford Corporation.

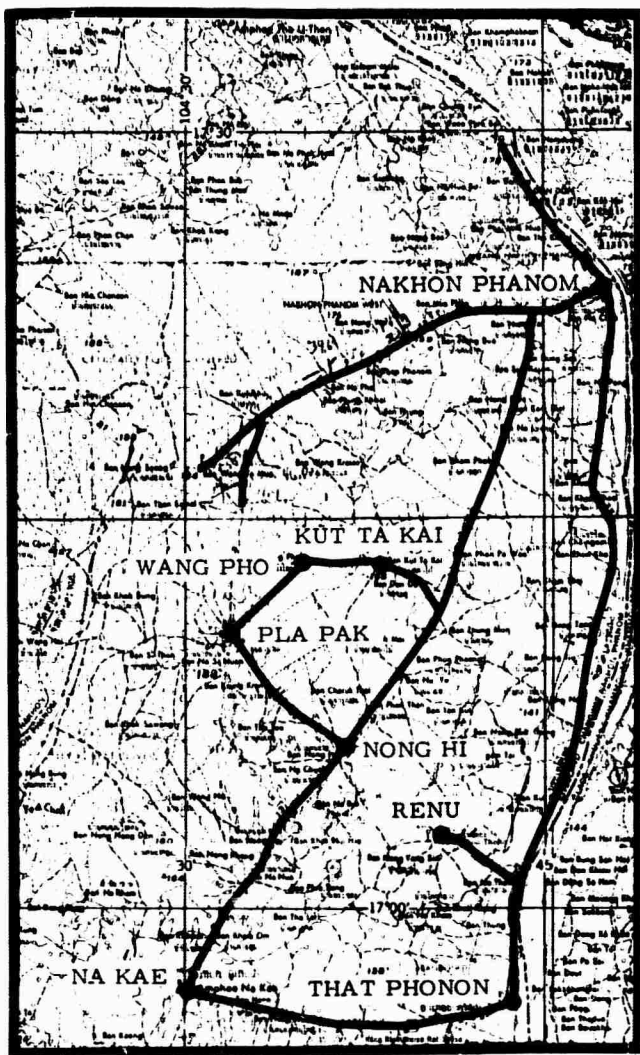

Figure 8. Sector of Nakhon Phanom Showing Routes Travelled by SAI Study Team.

Table 2. Road/Vehicle Network Data Examples

<u>ARD* ROAD: Nong Hi to Pla Pak</u>	
Time:	11:00 a.m.
Distance:	7.4 miles
Speeds:	30-40 mph
Bridges:	6
Vehicles on Road:	11 bicycles 2 oxcarts
<u>PIONEER ROAD: Pla Pak to Kut Ta Kai</u>	
Time:	1:00 p.m.
Distance:	8.9 miles
Speeds:	30-40 mph
Bridges:	2
Vehicles on Road:	several bicycles 4 oxcarts
<u>CART TRACK: Kut Ta Kai to Route 2033</u>	
Time:	1:30 p.m.
Distance:	3.6 miles
Speeds:	5-10 mph
Bridges:	2
Stream Bed:	1
Vehicles on Road:	4 bicycles
Miscellaneous:	Evidence of numerous mudholes; 4 large areas
<u>ALL-WEATHER ROAD: Nong Hi to Na Kae</u>	
Time:	2:30 p.m.
Distance:	14.6 miles
Speeds:	30-50 mph
Bridges:	10
Vehicles on Road:	1 minibus with hay 1 two-ton truck Numerous bicycles Several oxcarts

*Accelerated Rural Development

present anywhere in the area north of Na Kae. Bicycle repair shops appeared to constitute the only vehicle maintenance facilities in the area.

The speeds listed in the examples of Table 2 represent actual speed ranges used and could easily have been increased.

During the field survey, the ARD (Accelerated Rural Development) Highway Office in Nakhon Phanom was visited. Mr. Prichard, Chief Engineer of the ARD Nakhon Province office, provided data on highway programs and costs. Table 3 lists the construction and maintenance costs for roads in Nakhon Phanom Province.

Table 3. Road Costs

	Road Type	
	All-Weather	Service (Pioneer)
Construction Cost	130,000 B/KM	8,000 B/KM
Yearly Maintenance Cost	6,000 B/KM	-0-

(B = Baht; 20 Baht = One U.S. dollar)

The all-weather roads are designed to be 6M wide and have 0.2M of laterite surface over a prepared bed, while the service roads vary from 4 to 6M in width and have several inches of laterite surface.

Current planning data was obtained. For example, Table 4 lists the planned schedule of road segment construction. Not all of these projects are budgeted.

The priorities for these road segments were reported as established on the basis of

- security requirements
- population density
- economic considerations
- engineering

in that order. These determinations were made, apparently, by the central government offices in Bangkok.

The site survey revealed that those roads designated as all-weather were of laterite cap and in the dry season could be traversed by jeep or truck at speeds of 30 to 50 mph. Many of the oxcart trails, although rutted in many places, could be crossed by jeep at speeds varying from 10 to 15 mph. The "so-called" pioneer roads (if maintained) would be comparable to the all-weather roads in the dry season and could also be traversed by jeep or light truck at speeds up to 40 mph.

It would be important to determine the capability of the same vehicles during the wet season to establish some basis for comparison indicative of the vehicle-road compatibility. A series of field tests simulating varying road conditions of laterite in rainy season could provide data relative to the degradation of performance during

these periods. It is recommended that several types of vehicles (presently in use in the area) having several kinds of tires, ranging from conventional tires to Terra tires, be tested. The vehicle types tested should include heavy and light vehicles, including motor bikes. The effects of vehicles on roads under these conditions and the required or desired maintenance levels for the roads and vehicles could be determined. In addition, by using a specified region as a test area, such tests could provide opportunities for study of driver training under varying conditions.

SPECIFIC CASES: CALCULATED SOLUTIONS

The specific problem areas treated by parts of the SIMDATS simulation program were:

- (1) the security reaction time and stationing problem (NETSIM)
- (2) the economic road construction problem (ECON-ILP)

Because of the somewhat mathematical nature of the problem formulations, the quantitative details are relegated to appendices. Qualitative explanations which should be sufficient to explain the calculated data, however, are included in the appropriate parts of this section.

The appendices relating to the security problems are Appendices C, D, and E. Appendix C treats some aspects of the general formulation of the stationing problem and indicates how integer linear programming techniques could be applied. Appendix D describes the reaction time problem and the treatment of the stationing problem actually used for the calculations. Appendix E describes the corresponding computer program.

Table 4. Extracts from Schedule at ARD Office NKP
NKP Region Route Data (NKP, Na Kae, Pla Pak)

Route	Distance Km	Amphur	Villages	Population
Ban Nong Hoi Noi - Yod Chat	19	Na Kae	12	9,357
Huapoothon - Ban Dog Bung	6	Na Kae	5	2,085
Ban Nong Hoi Noi - Kane Nang	9	Na Kae	10	4,382
Ban Teppanom - Nong Din Daeng	25	NKP	17	8,446
Pla Pak - Kong Ee Nam	13	Pla Pak	12	5,359
Nakadow - Pla Pak - Nong Hee	5	Pla Pak	2	690
Qan Si Thon - Ban Na Mon	22	Pla Pak	7	4,184
Rasamaj - Don Daeng	10	NKP	11	5,768
Pla Pak - Kut Ta Kai	13	Pla Pak	5	4,516
Dong Luang - Soongplui	22	Na Kae	6	4,219
Bang Huang - Yod Chat	14	Na Kae	3	2,133
Kut Ta Kai - Ban Pon Tun	11	Pla Pak	5	4,534
Huapooton - Koksee	10	Na Kae	5	2,829
Donmuang - Pon Ngam	5	Na Kae	9	4,188

The economic problem is treated in the Appendices G, H, and I. The development of economic criteria is discussed in Appendix G, the mathematical formulation of the road building problem in Appendix H, and a brief description of the integer linear computer program is given in Appendix I.

Sample Study Region

A region in northeastern Thailand, consisting of sections of the amphoes of Na Kae and That Phanom and of the sub-amphoe Pla Pak was chosen for the SIMDATS sample calculations. A map of the region is shown in Figure 9; it displays a selected number of roads and villages as shown on the Army Map Service 1967 Series 1501, Sheets NE48-10 and NE48-14, Edition 1.

Not all roads and villages on the reference maps are shown in Figure 9; the major centers and principal roadways, however, are included as well as a representative sampling of smaller villages and minor links. The number of populated places shown for this example is thirty and the number of road segments is sixty-two. In the incremental road model followed, each node of the network, including junctions, must be specified: the 11 junction points not occupied by population centers are therefore also numbered on the figure, making the total number of nodes equal to forty-one.

The roads on the figure are divided into three classes:

- (1) First-class roads, shown in solid line. These correspond generally to graded laterite surfaces and are described as "all-weather".
- (2) Second-class roads, shown in dot-dash. These roads are taken to be almost equivalent to first-class roads in dry weather, but degrade in wet weather. For purposes of the model, they are taken to be equivalent to the proposed minimal roads, discussed in the Battelle Memorial Institute Report RACIC-TR-49.
- (3) Third-class roads, shown in dashes in the figure. These correspond to oxcart paths or ungraded trails or, in some cases, footpaths.

The road conditions shown are based on both Army Map Service data, aerial photographs, plus observations on site during field trips in northeast Thailand during the dry season. The accuracy of the sample network postulated is dependent upon knowledge of local conditions and vehicle capabilities. The versatility of this system allows for corrections to be included as they become available. The basic model was constructed in a manner that would allow for corrections and upgrading with minimum modification.

The network shown can now be used as a basis for the treatment of the transit times of various vehicles from one node to another and the cost effectiveness of transport within the

region. Times and costs for the original network can be compared to times and costs of network modifications involving road improvement and construction. A tradeoff of vehicle, road, and personnel costs can then be effected to assist in the planning and evaluation of any proposed network vehicle mix combination for either security purposes or for the achievement of specified economic, political, or social goals.

The next sub-sections present first some of the model results for security problem; then, some calculations of road effects on economic factors; and, finally, some effects of feedback between security and socioeconomic requirements.

Security Transportation Problems

Security problems in a region subjected to outbreaks of insurgency are many: the scheduling of patrols, the development of local counter-insurgency forces, the improvement of radio communications, the stationing of military or paramilitary groups in the region, and so on. The role of transportation and mobility in these problem areas is, of course, a crucial one, probably providing the most cost-beneficial possibility for improvement in security. In this section, the effect of mobility and network improvement on the military stationing (and, obliquely, patrol) problem is considered in the form of test case calculations typical of the general SIMDATS transportation simulation model.

One basic security-force stationing problem considered here can be expressed as the determination of the minimum forces required to police a region. Specifically, one might ask for the least number of security patrol stations, located at any points in the network, which are needed to get one security unit (perhaps four men and a vehicle) to any village or road junction in the region within a given time, the "reaction time." The answer naturally depends on this reaction time; it also depends on the type of vehicle used, the condition of the roads, and the season of the year. The program will select the optimal stationing points in the network, if desired. These points can, however, be restricted to certain possibilities by the program user; in addition, the need for security forces may vary within the network; this feature can also be treated in the program. For example, if insurgency outbreaks have historically tended to occur preferentially in some terrain types more than others, or in some types of politico-economic environments in preference to others, this data can be incorporated into the model.

The simulation model, then, can serve as a means of testing how a "reaction time" (response to outbreaks of insurgency) can be reduced by changing vehicle types or by improving roads or by adding security "supply stations". These changes and additions can be assigned appropriate costs and the tradeoff of these costs versus reaction time can be examined. The results of such examinations for the model region are given in this section. The figures illustrate some of the more salient cases, the complete calculated results are given in the tables. The details of the NETSIM computer programs, including sample program runs, are given

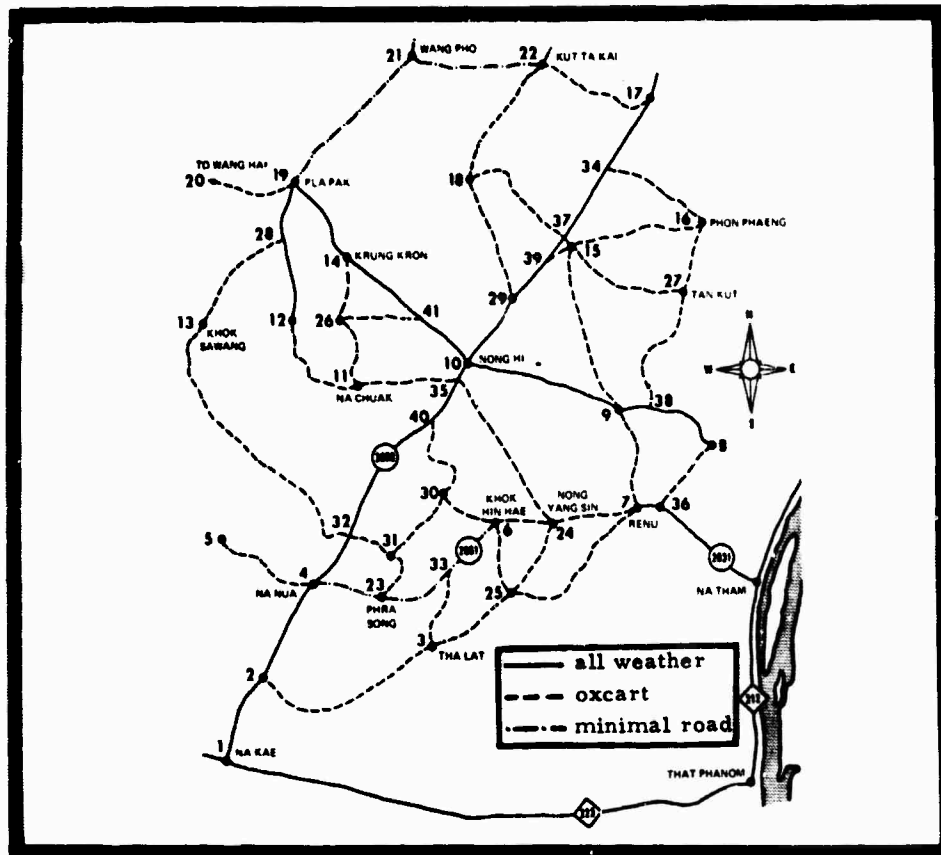

Figure 9. Sample Region: A Section of Nakhon Phanom Province in Northeast Thailand

elsewhere, in Appendices D, E, and F. Only the general idea of the program is needed to understand this section: transit times for given vehicle road conditions are inputs to the computer, which provides an output describing the minimum number of stations required to supply all villages and junctions within the reaction time T_R . As an example, refer to Figure 13, where the arrows indicate the routes from the supply stations to the "demand" points. The reaction time shown is $T_R = 0.50$ hour; so, for example, the arrows show that point 5 can be reached from point 33 in less than a half hour, as can point 13 from point 14 and point 27 from point 39. Some points can be reached from all three (most such overlaps are not shown, to avoid confusion), but four stations are necessary to reach all 41 points within one-half hour.

The sample region, as shown in the map figures, is characterized by 62 road segments of first, second, or third class condition. Table 5 gives the lengths and original condition of these segments.

The first sample case considered is that of jeep travel in dry weather over the original network; the average velocities adopted for vehicle-weather combinations are given in Table 6. These adopted speeds are very rough estimates and are only intended to be plausible values. The wet season values, in particular, require more definitive data; however, representative degradations were selected as an example: the value of

5 kilometers/hour for jeep travel over class 3 roads during the wet season is intended to represent some average of values between, say, 20 kph under locally favorable conditions and 0 kph when the path happens to be impassable. (The possibility of impassable conditions could be treated on a probabilistic basis, but such a treatment was not carried out in this model calculation.) It can be readily seen that the development of a real example, as opposed to the present realistic example, depends upon obtaining definitive data in field tests.

At any rate, given the lengths and velocities adopted in the tables, the sample region is displayed again in Figure 10, showing a "supply" (police) station at node 10 (Nong Hi). This station can cover the whole region (as explained above) in a reaction time of 1.10 hour (= 1 hour, 17 minutes) by jeep travel in dry weather.

Now one may consider the tradeoff between improved security response (reaction time) and the cost of establishing and maintaining security stations. Figure 11 a, b, c, d demonstrate the reaction time decreasing as the number of stations increases.

From Figure 11 a, it may be observed that the addition of one more station at the rather isolated point 20 (Wang Hai) can reduce the reaction time to 0.60 hour. In order to achieve a reaction time of 0.50 hour, Figure 11 b shows that 4 stations are necessary, at points 14, 20, 33 and 39. (These are not the only points at which the four stations

could be placed; indeed, one could restrict beforehand the location of allowed supply points to get specified solutions; this option will be considered below. For this sample analysis, it is only specified that four stations are necessary and that these four did represent possible choices.)

Progressing to shorter reaction times, it may be seen in Figures 11 c and 11 d that five stations are required for a reaction time of 0.40 hour and ten stations are required for a reaction time of 0.30 hour. Additional cases are included in Table 7.

Figure 11 indicates a general result of the simulation program, that is, the required number of stations increases rapidly for shorter reaction times. The situation in Figure 11 when translated into dollars, as shown in Figure 12, demonstrates the achievement of reaction time as a function of money spent for maintaining security stations. In this example, the cost of maintaining a station is set somewhat arbitrarily at \$5000 per year.

The considerations of Figures 11 and 12 should enable an analyst to pick out the most cost-beneficial disposition of security stations. If the solution chosen were, for example, the four-station solution of Figure 11 b, then Figure 13 shows how a threat would be met at any point in the network from those four stations. The station at point 20, in this model, is isolated, but the other three stations would use, preferably, the routes

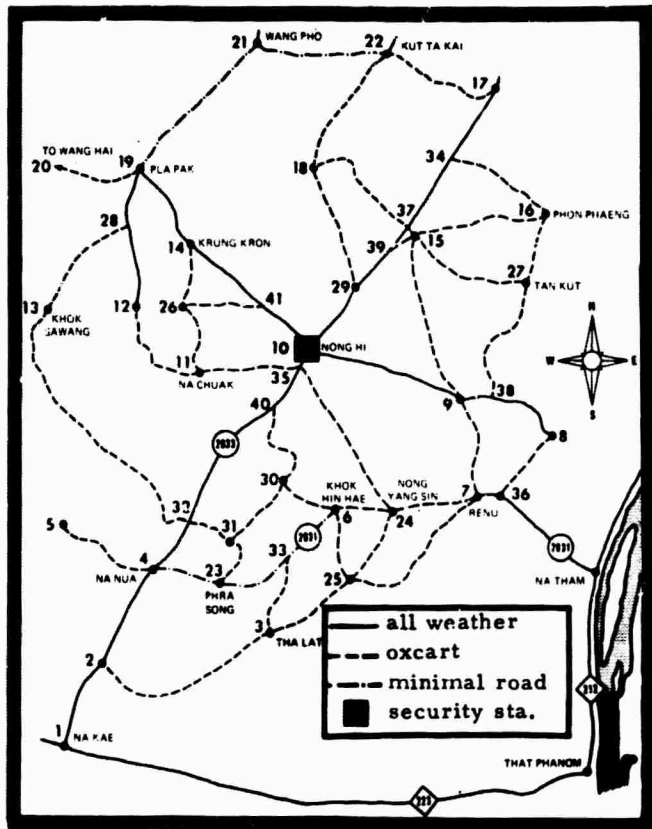

Figure 10. Security Stations: Jeep transport, dry weather, original network, reaction time $T_R = 1.10$ hour

Table 5. Road Segments, Conditions and Lengths

Road Segments (identified by endpoints)	Class (condition)	Length (Km)
1-2	1	4.0
1-36	1	39.9
2-3	3	8.8
2-4	1	4.0
3-25	3	3.7
3-33	3	3.1
4-5	3	4.9
4-23	2	2.7
4-32	1	2.8
6-24	3	2.3
6-25	3	3.1
6-30	3	3.6
6-33	2	3.8
7-9	3	4.8
7-24	3	3.8
7-25	3	7.5
7-36	1	1.0
8-36	3	3.7
8-38	1	4.4
9-10	1	7.5
9-15	3	7.5
9-38	1	1.3
10-29	1	3.1
10-35	1	1.2
10-41	1	3.0
11-12	3	5.0
11-26	3	3.7
11-55	3	4.6
12-28	1	3.8
13.28	3	5.6
13.32	3	13.0
14-19	1	4.8
14-26	3	2.7
14.41	1	4.2
15-16	3	6.2
15-27	3	6.0
15-39	3	1.0
16-27	3	3.1
16-34	3	5.0
17-22	3	8.0
17-34	1	3.8
18-22	3	6.3
18-29	3	5.6
18-37	3	5.6
19-20	3	13.0
19-21	2	8.1
19-28	1	2.5
21-22	2	4.8
23-31	3	2.7
23-33	2	3.2
24-25	3	4.4
24-35	3	8.1
26-41	3	3.6
27-38	3	6.0
29-39	1	2.5
30-31	3	4.0
30-40	3	5.0
31-32	3	2.5
32-40	1	7.5
34-37	1	3.7
35-40	1	1.5
37-39	1	1.2

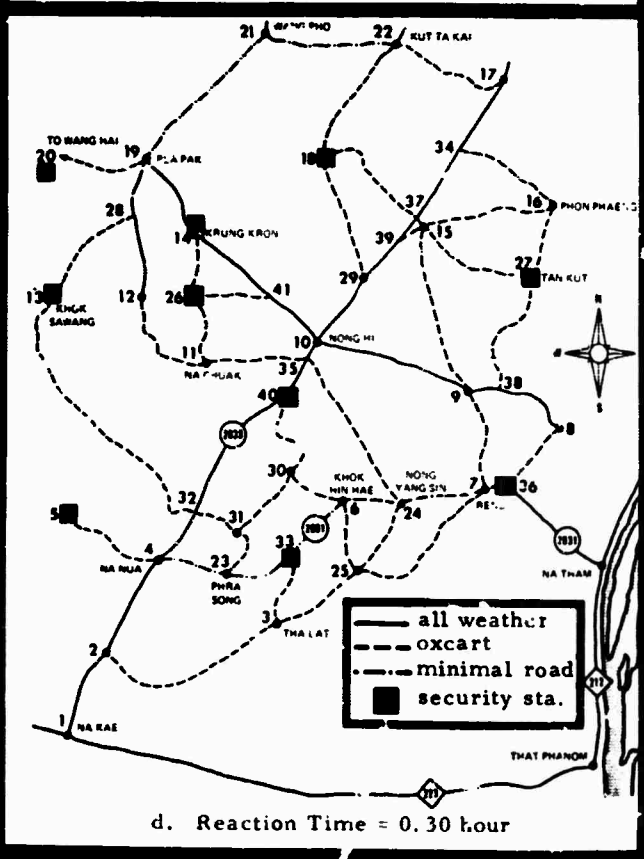
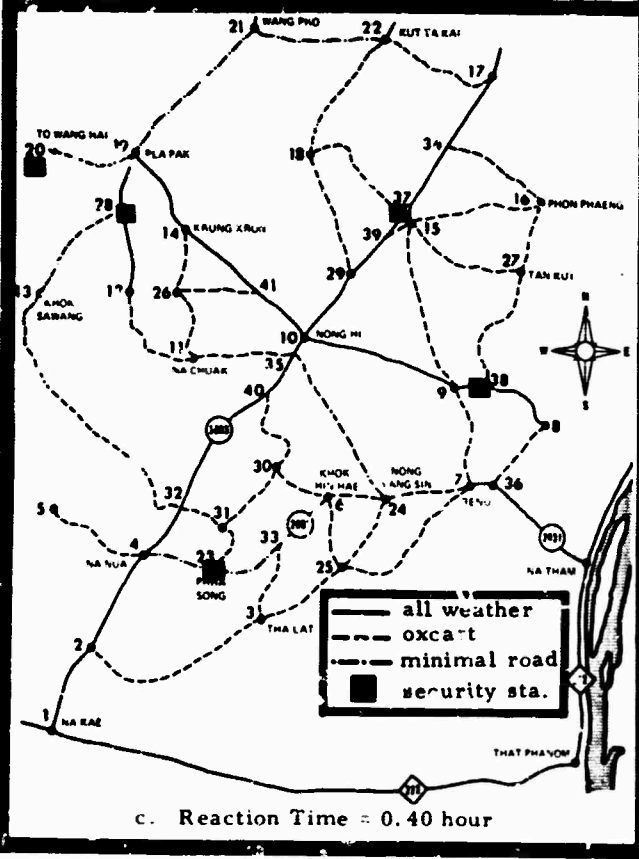
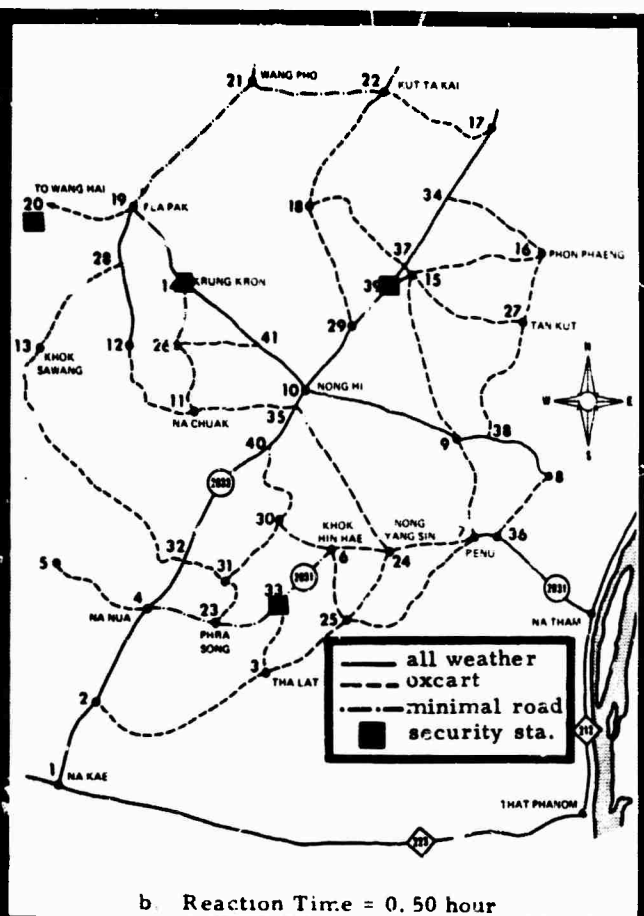
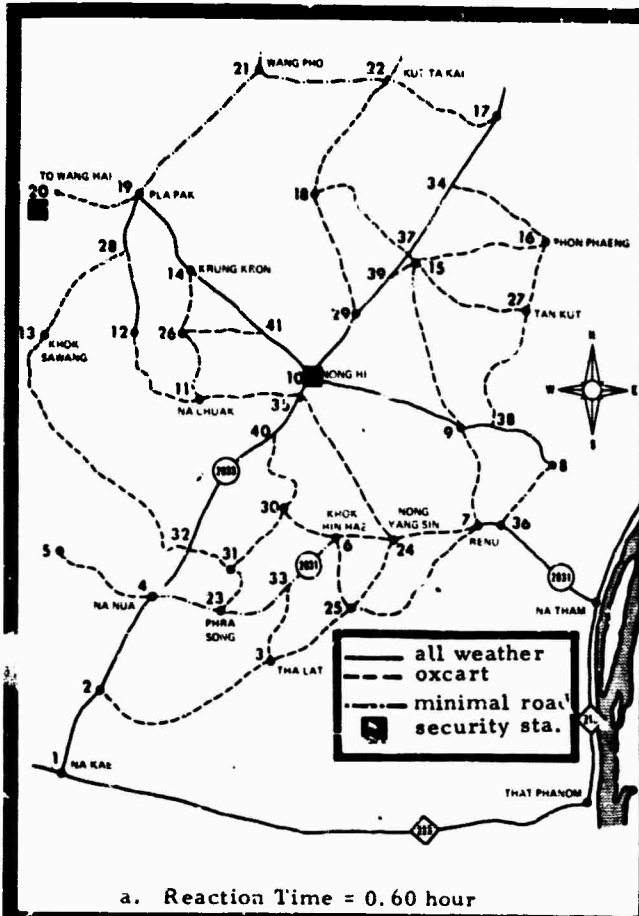

Figure 11. Security Stations: Jeep transport, dr, weather, original network

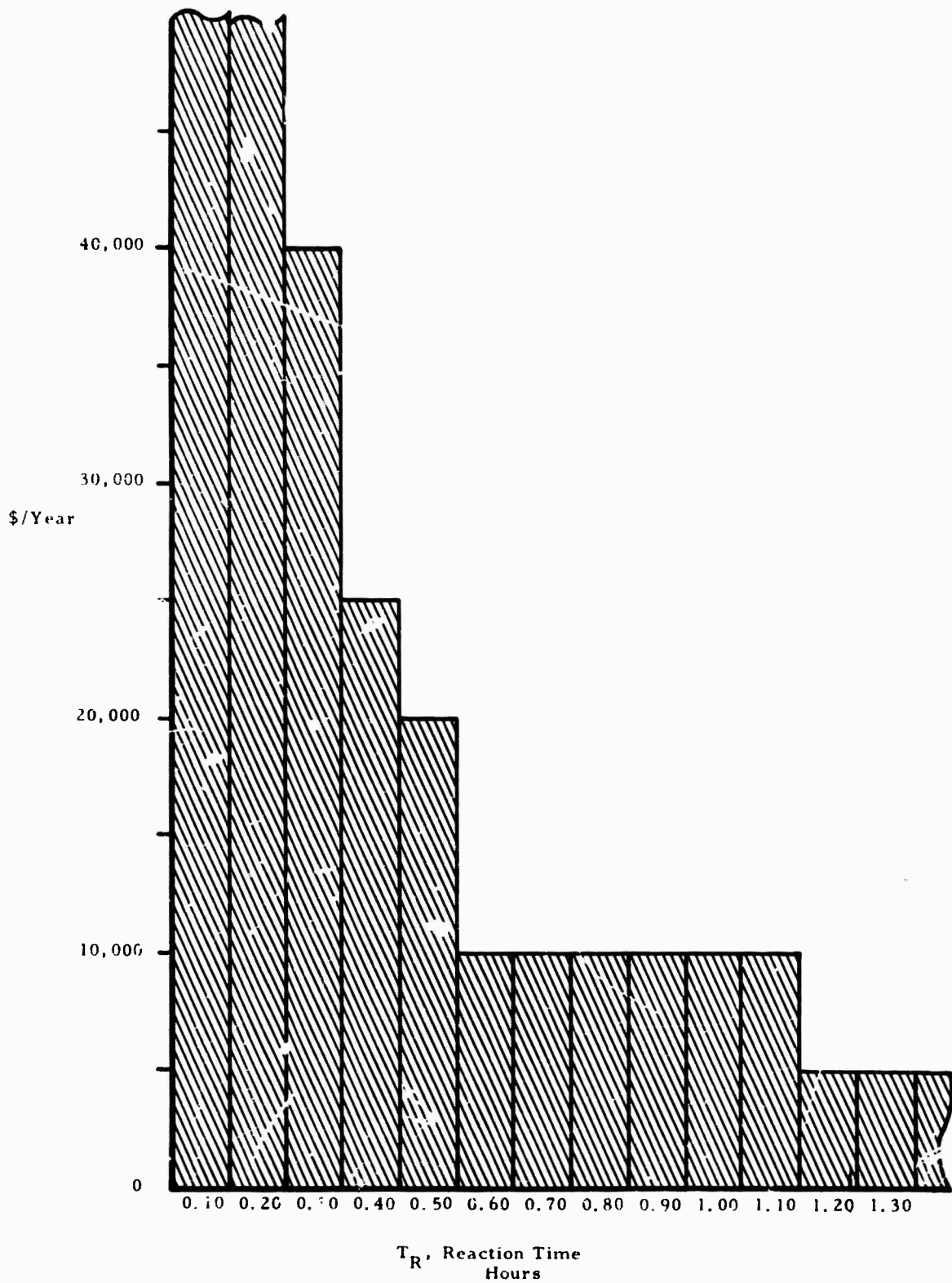

Figure 12. Reaction time achieved versus money spent/year on stations.

Table 6. Average travel speeds adopted for vehicles as functions of weather and road class. Speeds in kilometers/hour.

Vehicle Weather	Road Class		
	1	2	3
Jeep, dry	65	60	15
Jeep, wet	60	30	5
Rcte, dry	30	30	20
Rote, wet	28	20	10
Helicopter, clear	100	100	100

shown. For times greater than or equal to a half-hour, all points could be covered; for lesser times, coverage would be partial. This partial coverage can be shown in time ticks or constant travel time contours. These contours can be calculated by the SIMDATS program; an example is given in Figure 14.

If we restrict ourselves to the case of jeep dry weather travel, the effect of limited amounts of road modification or reaction time may not be too great, as shown in Table 7. As an example, the effects of changing the class 3 (oxcart) roads 8-36, 6-24, and 7-24 to class 1 (all-weather) were examined, with essentially negative results. Of course, further trial would disclose which road improvements could lead to reduced dry season reaction time for fixed station number. For the purposes of this model calculation, however, further exploration of this sort was restricted to the wet season case, described later in the section.

Before examining the wet season cases, it is instructive to consider the results given in Table 7 of restricting a priori the possible supply (or demand) nodes as shown in Figure 15 a, b. These possible supply nodes are restricted here to points 1, 3, 4, 5, 6, 7, 10, 14, 16, 19, 20, 21, 23, and 24, but all nodes have an associated demand, as before, of one security unit. The allowable nodes are shown in the figure as open circles. For $T_R = 0.50$ hour, the solution is the same as the unrestricted supply case in Figure 11 d. For $T_R = 0.50$ hour, the restriction makes a five-station solution (rather than four, as in Figure 11 b) necessary. For $T_R = 0.40$ hour, however, there is no solution. This restriction upon possible supply nodes demonstrates the effect that short reaction times impose on station location.

The case of restricted demand, also shown in Table 7, serves as an illustration of the situation in which insurgency is expected only at selected points of the area. Here, too, the road modifications essayed have a non-trivial effect in the reduction of reaction time, as shown by comparing Row 6 with Row 8 in the table.

In Table 8, the effects of vehicle changes and road modifications are examined for travel during the wet season. Some limited road modifications are examined for jeep travel and the effect of replacing jeeps by ROTE (Rolligon or Terra tire-equipped) vehicles. Figure 16 a, b, c compares the number of stations needed for jeep travel with the number needed for ROTE vehicle travel for two reaction times. The ROTE vehicles, as expected, reduce the reaction time in wet season for number of stations held fixed. As seen from the table, however, the maximum reduction in static reaction time (for a given reaction time) by replacing jeeps by ROTE vehicles is 50%, while it seems quite likely that the cost of operating a ROTE vehicle is more than twice that of operating a jeep. Therefore, if the model were to be taken seriously, the use of jeep stations would be the most cost-effective in the situation. It is, however, more than likely that the model parameters are weighted too much in favor of jeep travel. Therefore, one must again caution that the jeep-ROTE comparison should be taken as an example of the kind of conclusions that could be drawn if adequate data were taken in the field and incorporated into the simulation. Considerations should also be taken of the possibility of altering the jeep (e.g., Terra-tires) for wet weather operation. This, of course, suggests a requirement for specific field testing.

Another type of tradeoff is that of road construction expenditures versus station maintenance costs; this was discussed briefly in the dry season cases. Figure 17 illustrates one of the possibilities taken from Table 5: the modification of the segments 26-41, 15-39, and 15-16 to all-weather roads (class 1). These road modifications would enable the security forces to eliminate one station (shown by the empty square). The cost of constructing the road links shown (from the economic model discussion below and from the lengths given in Table 5) is over \$20,000/year (10.6 kilometers at an amortized cost of \$2,170/km/year), so that if the station cost is \$5,000/year, as postulated before, the road construction would not be justified for military purposes alone. Again, it must be said that these conclusions are realistic in form, but not real, because of the absence of adequate data.

The cross-dependences of the vehicle and road parameters, together with seasonal effects, has now been illustrated. As a final example, consider a perhaps more "realistic" case in which the supply points are restricted to certain main towns (because of political or economic factors); in this case, points 1, 4, 6, 7, 8, 10, 17, 19 and 22. It has been noted above that the isolated town 20 (Wang Hai) often requires a station of its own. It will probably be cheaper to build and maintain at least a second-class road or the segment 19-20 (13 kilometers at \$283/km/year) than to maintain a station there, so that one can assume that this route is always to be improved. One can also consider improving other routes to shorter military response time; the network changes considered here are the links 4-5, 8-36, 13-28, (19-20), 15-39, 15-27, 26-41 and 18-37. Wet season response is the most difficult to obtain, so only the wet season accessibility is considered. Then Table 9 shows the results for four cases:

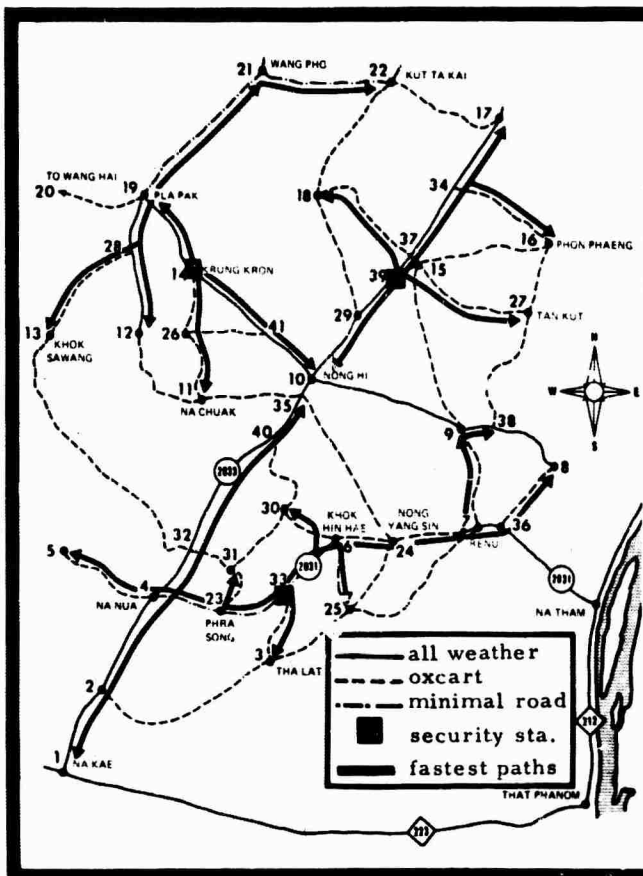

Figure 13. Fastest paths followed in meeting threats (situation of Figure 11 b).

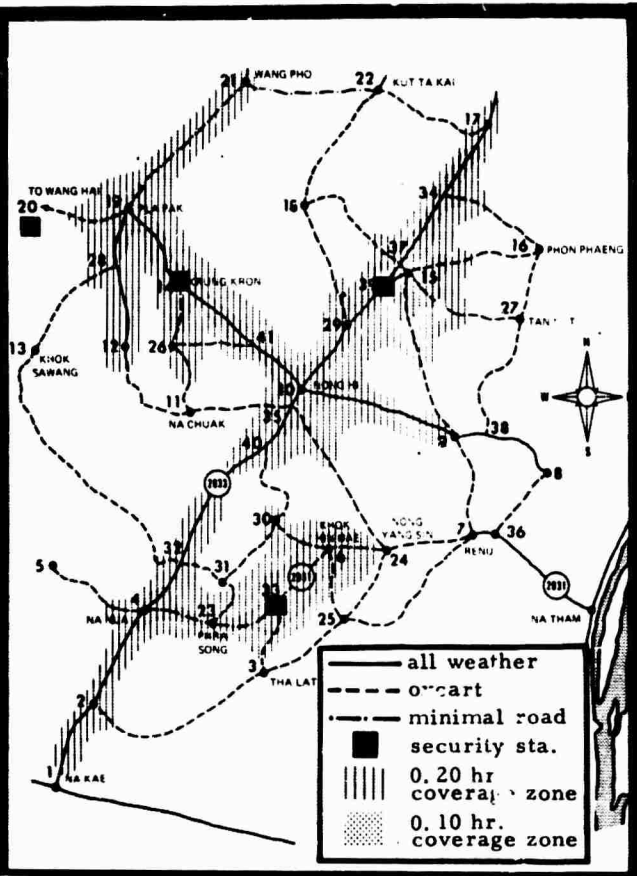

Figure 14. Time ticks: Travel contours (situation of Figure 11 b) in fractions of hours.

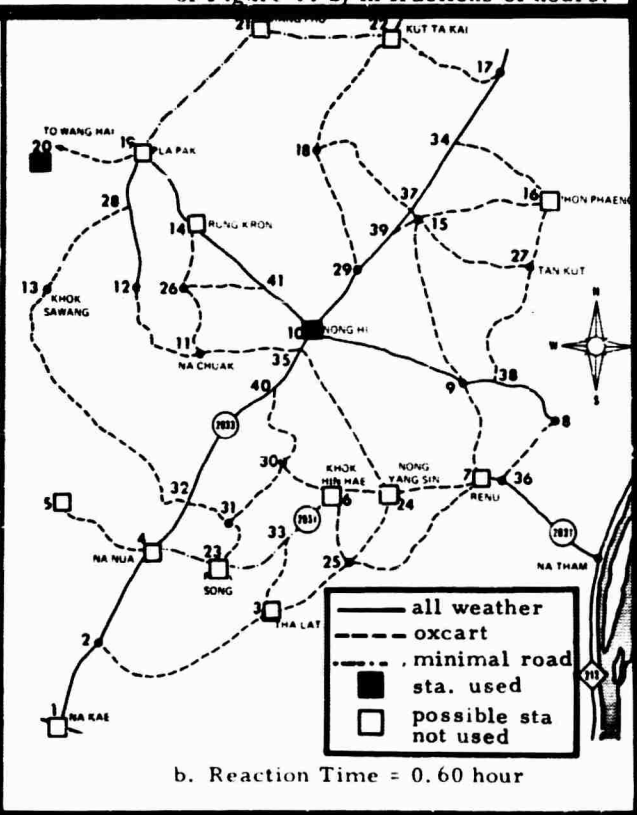
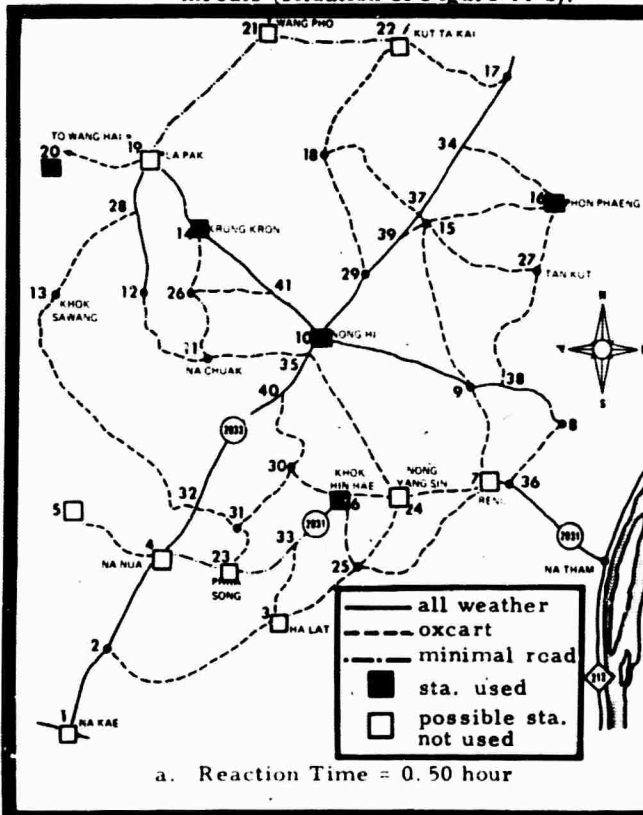

Figure 15. Security Stations (restricted choice). Stations restricted a priori, jeep travel. The open squares show allowable supply nodes; the filled show those actually used.

Table 7. Security station solutions for various reaction times, jeep travel in dry season as a function of supply and demand restrictions and of various road modifications. (Numbers in table refer to node identification figures on map-figures.)

Row No.	Supply-Demand Restrictions	Route Modification	Reaction Times (hours)						
			0.20	0.30	0.40	0.50	0.60	0.70	1.20
1	None	None	3, 5, 6, 11, 13, 14, 16, 18, 19, 20, 25, 27, 30, 32, 36, 38, 39	5, 13, 14, 18, 20, 26, 27, 33, 36, 40	20, 23, 28, 37, 38	14, 20, 33, 39	10, 20	20, 41	10
2	None	8-36 made Class 1	3, 5, 6, 11, 13, 14, 16, 18, 19, 20, 25, 27, 30, 32, 38, 39	5, 13, 18, 20, 26, 27, 28, 33, 35	20, 23, 27, 28	14, 20, 32, 38	10, 20	20, 41	
3	None	6-24, 7-24 made Class 1	3, 5, 6, 11, 13, 14, 16, 18, 19, 20, 25, 27, 28, 30, 32, 38, 39	5, 13, 14, 18, 20, 26, 27, 33, 40	20, 27, 28, 23, 37	14, 20, 32, 39	10, 20	10, 41	
4	None	8-36, 6-24, and 7-24 Made Class 1	3, 5, 11, 13, 14, 16, 18, 19, 20, 23, 25, 27, 29, 30, 38	5, 6, 13, 14, 18, 20, 26, 27, 40	20, 23, 27, 28, 37	14, 20, 32, 39	10, 20	10, 41	
5	Supply nodes restricted to 1, 3-7, 10, 14, 16, 19-24	None	No Solution	No Solution	No Solution	6, 10, 14, 16, 20	10, 20	14, 20	
6	Demand nodes restricted to 1, 3-7, 10, 14, 16, 19-24	None	3, 5, 16, 19, 20, 24, 32, 36	5, 20, 27, 28, 33, 36	20, 32, 36, 37, 41	10, 20, 40	20, 41	20, 41	
7	Supply and demand nodes restricted to 1, 3-7, 10, 14, 16, 19-24	None	3, 4, 5, 7, 16, 19, 20, 24	5, 16, 19, 20, 23, 24	10, 16, 20, 23, 24	6, 10, 20	10, 20	14, 20	
8	Demand nodes restricted to 1, 3-7, 10, 14, 16, 19-24	8-36, 6-24 and 7-24 made Class 1	3, 4, 5, 16, 19, 20, 38	5, 20, 27, 28, 33	20, 32, 37, 41, 40	10, 20, 40	20, 41	20, 41	

- (1) Jeep, only 19-20 modified to second class.
- (2) Jeep, all routes listed modified to first class.
- (3) ROTE vehicle, only 19-20 modified to second class.
- (4) ROTE vehicle, all routes modified to second class.

The jeep first class, ROTE second class option represents the logical tradeoff of cheap vehicle with expensive road and vice versa. As before (in Table 7), the restriction of possible supply points means that there exists an absolute minimum reaction time for each case; the first value shown in each row then belongs to the

minimum reaction time. Figure 18 a, b shows two of the resulting two-station solutions.

This set of comparable cases can be thought of as buying time with road construction or vehicle purchase dollars. In Figure 19, the minimum reaction times obtainable in the four cases are plotted against the amount of money spent for stationing plus road, construction costs. (The ROTE station was taken as costing \$12,500 per year, the jeep as \$5,000 per year, and the road costs calculated as described previously.)

For purposes of a time scale comparison, and to emphasize that the logic of the program is not confined to road transport, Figure 20 shows the case for helicopter supply to all nodes, helicopter stations restricted to points on all-weather roads.

Table 8. Wet season security station solutions for jeeps, original network and modified networks, and ROTE (Rolligon or Terra tire-equipped) vehicles.

Vehicle Type	Road Modification	Reaction Times (hours)														
		0.75	0.80	0.85	0.90	0.95	1.00	1.05	1.10	1.15	1.20	1.25	1.30	1.35	1.40	1.45
Jeep	None	2, 5, 6,	5, 6,	4, 5,	5, 13,	5, 13,	4, 13,	4, 13,	13, 18,	20, 27,	19,	19,	14,	20,	20,	20,
		12, 18,	13, 18,	13, 18,	18, 20,	18, 20,	18, 20,	18, 20,	20, 27,	28, 32,	20,	20,	19,	38,	41	41
		20, 26,	20, 26,	20, 26,	26, 27,	22, 27,	27, 40	27, 40	32	38	35,	38,	20,	41		
		27, 41	27, 36,	27, 33	32, 33	33, 40	41				38	41	41			
Jeep	Routes 7-9, 6-24, 7-24 modified to Class 1	5, 6,	5, 6,	5, 13,	5, 13,	5, 13,	5, 13,	5, 13,	5, 13,	13, 18,	20, 28,	19,	19,	14,	20,	20,
		13, 18,	13, 18,	18, 20,	18, 20,	18, 20,	18, 20,	18, 20,	20, 27,	28, 32,	20,	20,	19,	38,	41	41
		20, 26,	20, 26,	26, 27,	26, 27,	26, 27,	27, 35,	27, 35,	27, 40	32	38	35,	38,	20,	41	
		27, 41	27, 41	4, 33	36	36	36	36								
Jeep	Routes 15-27, 15-39 and 26-41 modified to class 1	2, 5, 6,	5, 6,	4, 5,	5, 13,	5, 13,	5, 13,	5, 13,	5, 13,	13, 18,	20, 28,	19,	19,	14,	20,	20,
		13, 18,	13, 18,	13, 18,	18, 20,	18, 20,	18, 20,	18, 20,	20, 32	32, 38	20,	20,	20,	41	41	41
		20, 26,	20, 26,	26, 32,	32, 33,	23, 33,	40	40	5, 40	35	41	41				
		39	36, 39	39, 41	41	41	41	41	or 5, 32	or 32, 40						
Rote	None	20, 23,	5, 19,	14, 20,	14, 20,	14, 20,	20, 33,	20, 32,	10, 20,	20,	19,	19,	40	41		
		28, 38,	26, 29,	23, 29	29, 33	33, 35	40, 41	41	32	40	40	40				
		39	36	36												

Table 9. "Realistic" restrictions on supply points. Jeep and ROTE vehicles, "little" (19-20) modification vs. "extensive" (4-5, 8-36, 13-28, 15-27, 15-39, 18-37, 19-20, 26-41) modifications. Wet season. Supply points needed listed by node number.

Case No.	Vehicle	Road Modifications	Reaction Time (Hours)													
			0.70	0.75	0.80	0.85	0.90	0.95	1.00	1.05	1.10	1.20	1.30	1.35	1.40	
1	Jeep	19-20 2nd Class	← None →						8	10	10					
							6	6	6	6	4	10			19	
2	Jeep	4-5, 8-36, 13-28 15-27, 15-39 18-37, 19-20 26-41 1st Class	← None →													19
3	ROTE	19-20 2nd Class	← None →		4	4	4	4	6	6	6	8	10		10	
					8	8	8	10	10	10	10	10				
					17	17	10	19	19	19	19					
					19	19	19	19								
4	ROTE	4-5, 8-36, 13-28 15-27, 15-38 18-37, 19-20 26-41 2nd Class	4	4	6	6	6	6	6	6	8	8	10		10	
			6	7	10	17	10	10	10	10	10	10				
			10	17	17	19	19	19	19	19						
			17	19	19											
			19													

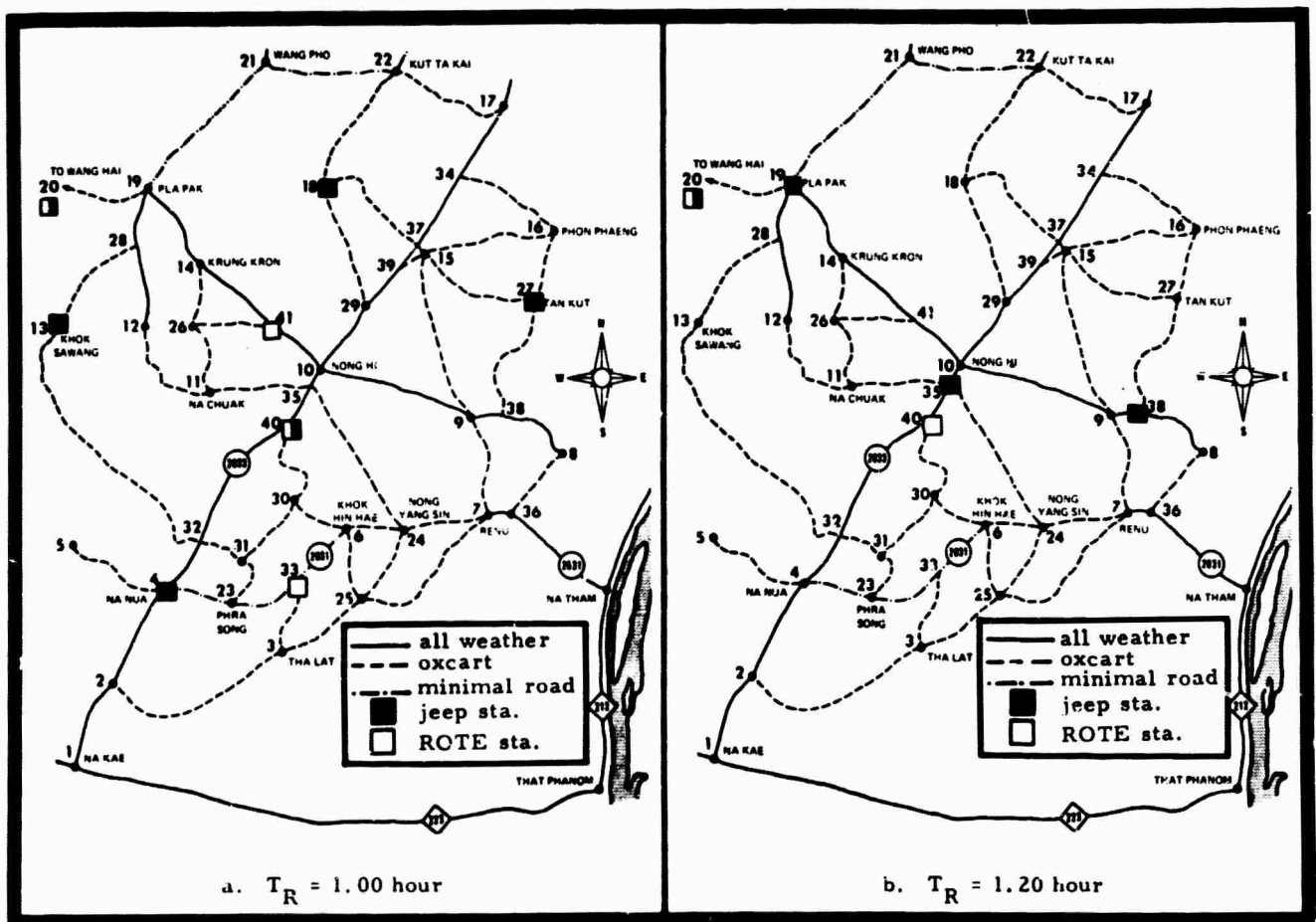

Figure 16. Security Stations (vehicle effects). Wet weather network, stations required for jeeps versus those required for ROTE vehicles.

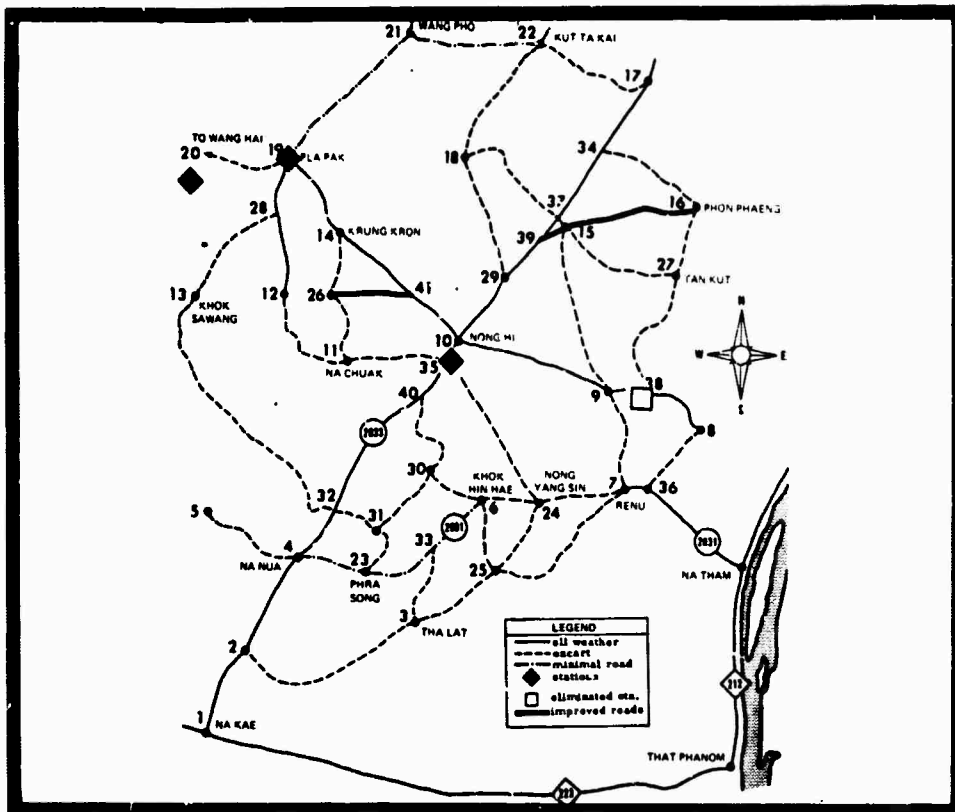

Figure 17. Security Stations (road construction effects). Jeep, wet weather travel, new all-weather (1st class) roads shown in heavy line, eliminated station by the empty square.
 $T_R = 1.20$ hour

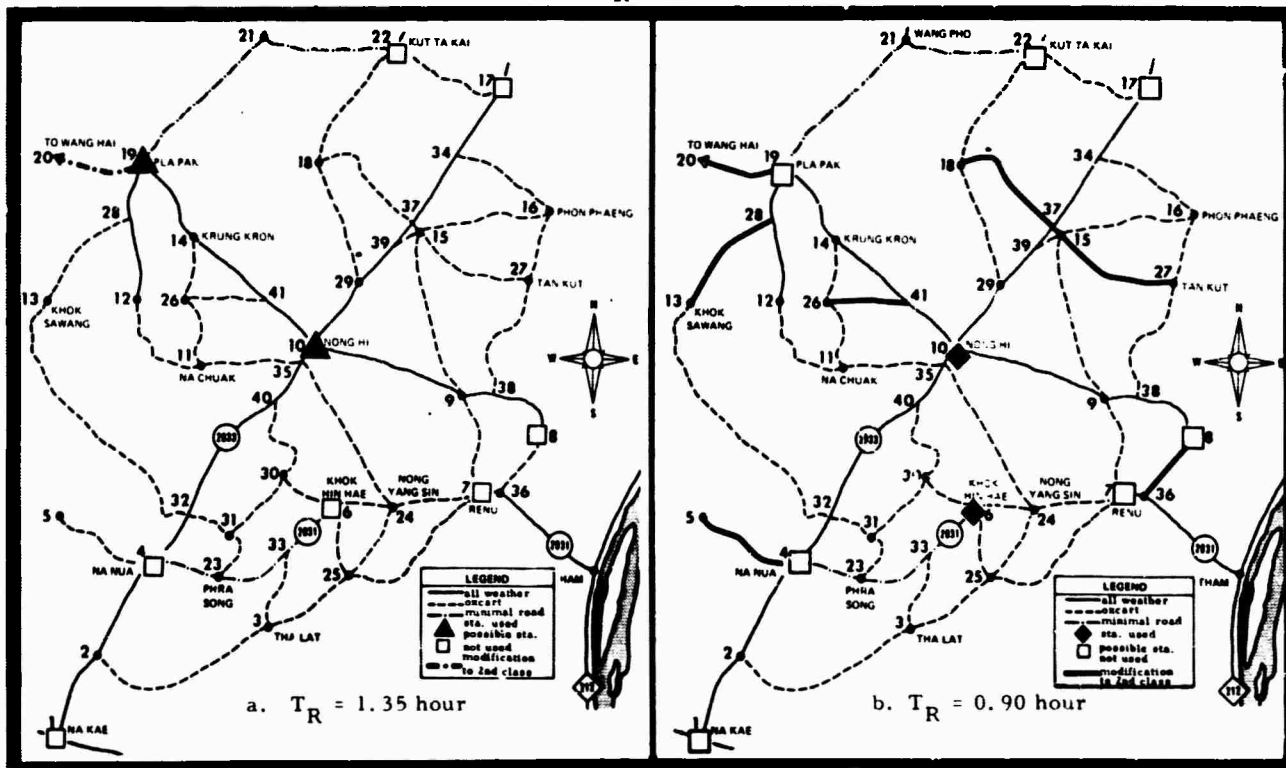

Figure 18. Road modification and reaction time. Jeep, wet-weather, two station solution for restricted stationing possibilities. Open squares show allowed supply points not needed.

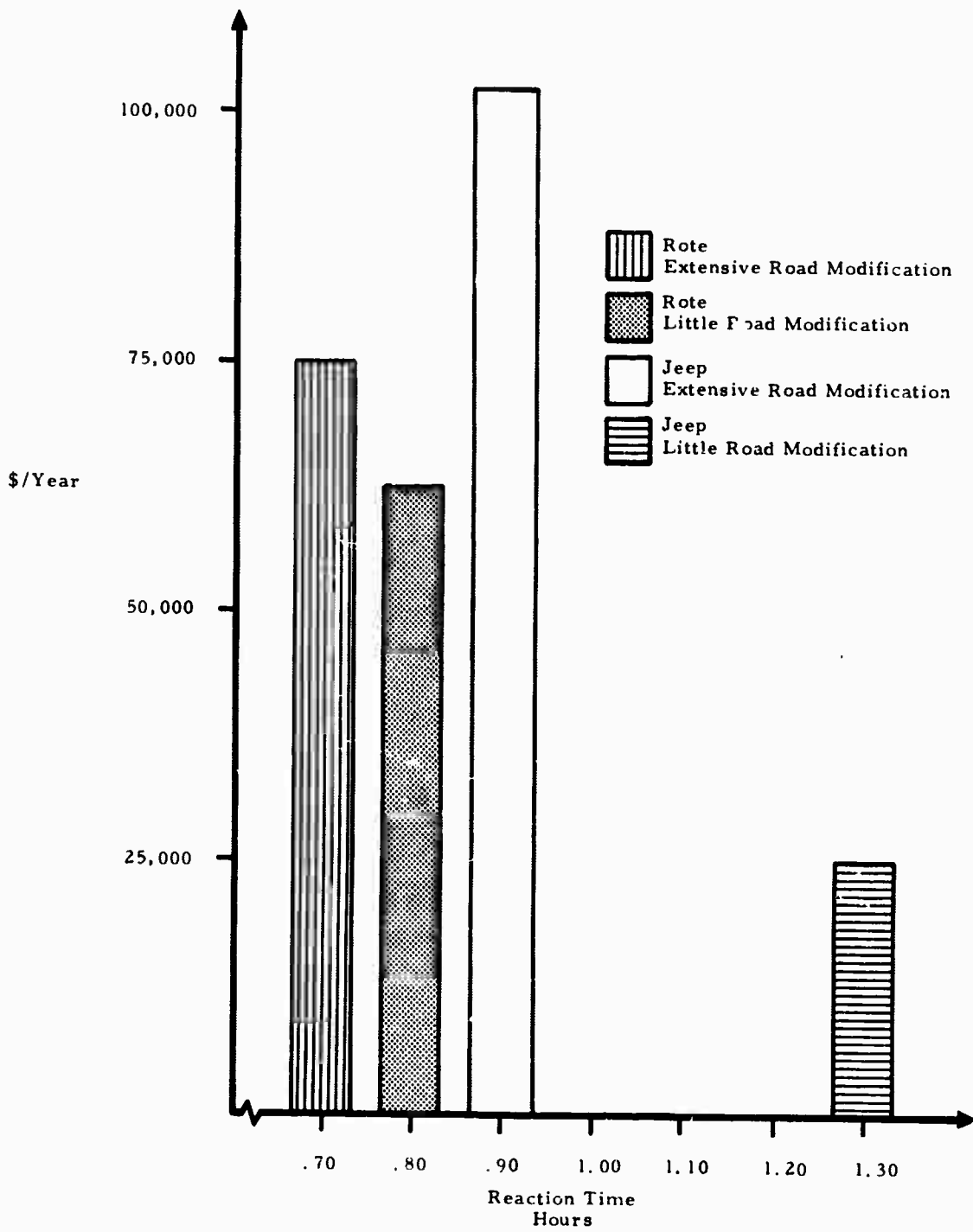

Figure 19. Minimum reaction time achieved versus total cost/year for four "realistic" options. (See Table 6.)

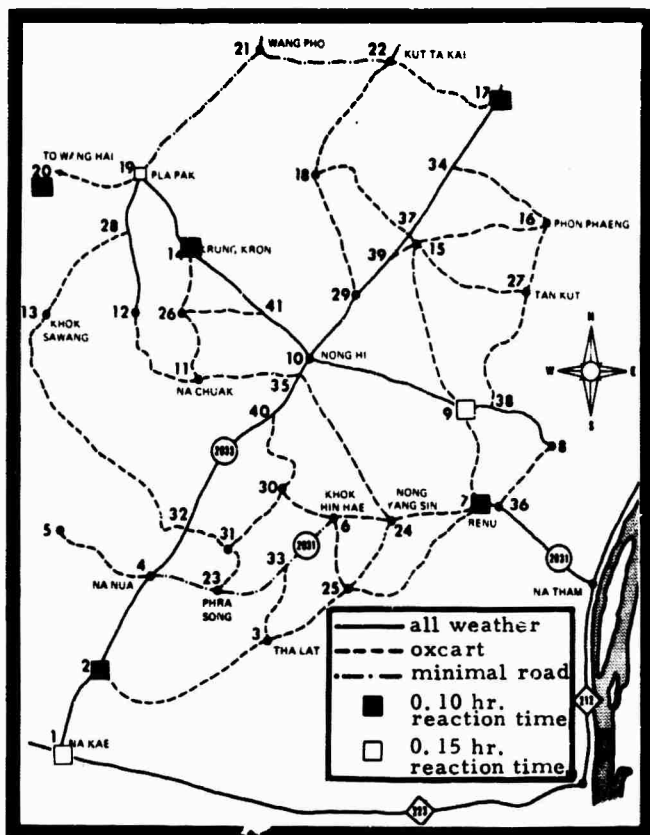

Figure 20. Helicopter Security. Stations for helicopter, restricted where possible to villages on all-weather road.

The Economic Problem

In this section, the problem of planning transportation improvements is considered in its relation to the economic betterment of the sample region. The planning decisions in a particular case may happen to be very easy to make: for example, in our region, the construction of a dam at the Lat (node 3) might make the link 2-3 an overwhelmingly desirable choice for upgrading. Similarly, the establishment of a new rice mill at node 18 might indicate that priority should be given to improvement of the link 18-29. Obviously, simple combinations of such situations can be treated by intuition.

When the situation becomes more complicated, however, the decisions become difficult. An example of how this type of complicated problem - that is, the problem of deciding between many economic needs at many places - can be solved has been worked out using the ECON-ILP subprogram of the SIMDATS simulation. The development of economic criteria for a complex region is discussed in Appendix G, the mathematical formulation of ECON-ILP in Appendix H, and the details of the ECON-ILP computer program in Appendix I. All that needs to be known to understand the present section is that the ECON-ILP model calculates an "inferred future usage" for the road segments in question. This "inferred future usage" is derived by making simulated shipments to all node points from a selected number of "entry ports" or supply nodes.

When actual usage measurements are available, they can be used instead of, or as a supplement to, the simulated usage figure; in this case, as in many real decision situations, no such usage measurements were available. Such measurements should be assigned a high priority in the development of a real-world simulation.

Once the road usage is established, the contribution to the price structure of the region made by each road can be derived. The goal of the calculation is then to reduce the average prices (or average transport costs) in the region, as much as possible. Obviously, in an ideal world the greatest price reduction can be achieved putting in first class roads between all links. In the actual world, there is usually not enough money available for complete improvement. The complete problem posed, then, is to improve roads so as to reduce the price level of the region as much as possible, when the amount of money available for road construction is limited.

It is straightforward, in principle, to enumerate all the possibilities for solutions to this problem and to pick out the best one; in practice, however, this may be impossible. For example, in the simple region shown, there are 30 segments of third class road which could be made into second class or first class links, and 5 segments of second class road which could be improved to first class links. This means that there are 6×10^{15} possible combinations (for arbitrary funds available) of road improvements possible, even for this small area. At the rate of a million computations a second, even a large present day computer would require 200 years to carry out the calculation! Fortunately, integer linear programming techniques provide a short-cut method of finding the exact answer in a finite time.

The solution of the problem for all road links, even so, would require a rather large expenditure of computer time; for the purposes of the model calculation, it was thought sufficient to consider improving only the ten links shown in Figure 21, five links of second class road which could be upgraded to first class, and five links of third class road which could be upgraded to second class or first class road - all together 15 different individual possibilities (about 8,000 combinations).

The data needed in the economic road building model are then of two kinds:

- (1) node data or "weights"
- (2) segment data or cost-effectiveness

The node data or weights are measures of the consumer demand at a given node relative to the other nodes, and consequently also a measure of the relative weight of a given node in the overall price structure of the region. These weights could, in principle, be assigned directly from the known actual demand for a given product at the node, or indirectly through the population and economic (agricultural, industrial, etc.) importance of the node. In fact, for this model calculation, even village-by-village population statistics were not available, so that only a rough estimate, using available tambon statistics and impressions from

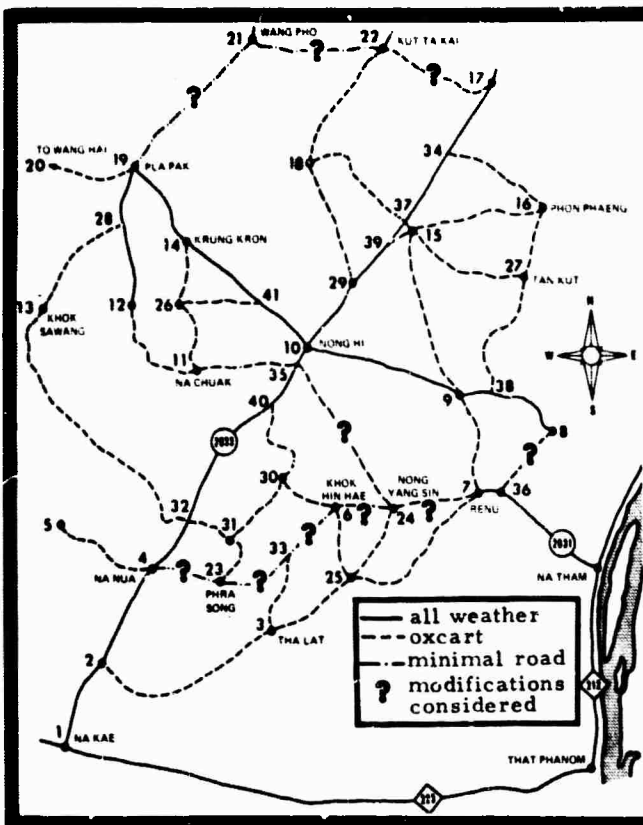

Figure 21. Planner's Preselection of Road Improvement Possibilities

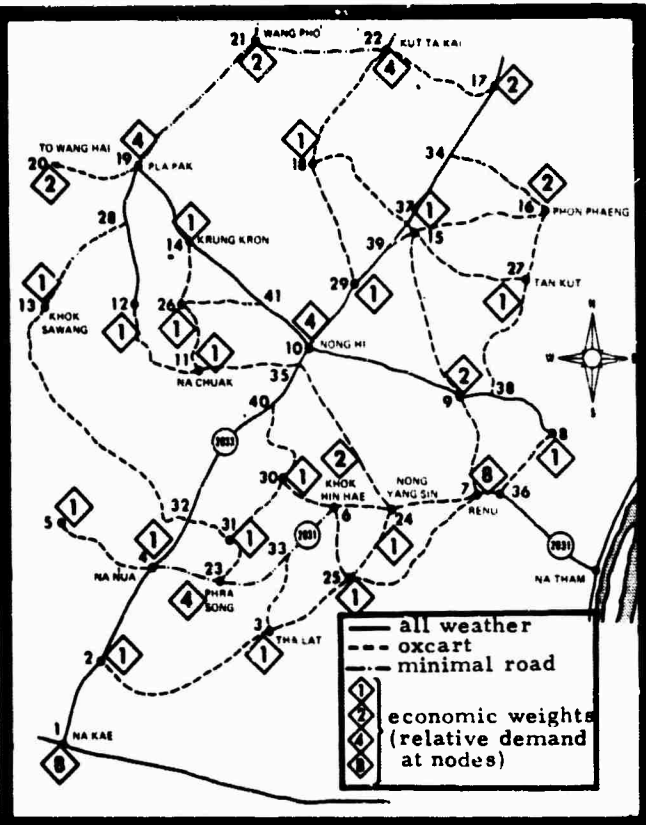

Figure 22. Relative Economic Weights. Model "weights" (measures of relative population, agricultural, and industrial importance, for subregions served by inhabited nodes, arbitrary units).

the DATS field trip, could be made for the nodes of the region. The adopted weights are shown in Figure 22; the units are arbitrary because only the relative price structure is needed (fortunately) for the making of road construction decisions. It should be noted that even under the best of circumstances, there would be some understandable uncertainty about these economic values or weights. For serious planning, it would be advisable to introduce probabilistic methods. One simple but effective way would be to introduce random Gaussian fluctuations about the adopted weight values. Preliminary investigations indicate that for networks of reasonably great size, these fluctuations would tend to smooth out collectively.

The segment data needed consists of the relative cost-effectiveness figures for each road segment. The basis for the cost-effectiveness calculation is given in Appendix H: the cost-effectiveness numbers used in deriving relative usage are given by the considerations there and the lengths given in Table 5. Table 10 lists the resulting values as used.

Table 11 gives the individual "segment" factors" described in the appendix; for the purposes of this discussion, these correspond to the simulated usage values. Table 12 gives the final coefficients of each road segment in the price level function and in the road construction

budget function; the price function is to be maximized while the road construction budget is kept under a maximum predetermined value.

The final results produced by the ECON-ILP routine are shown in Figures 23 and 24 a, b for various values of the budget.

The map figures show the expected feature that as the budget is increased, the number of improved segments tends to increase (note, since there are many construction options, this increase is only a tendency); a not-so-obvious feature can be seen by comparing Figure 24 a and Figure 24 b. While intuitively one might suppose that as the budget rises from \$20,000 to \$30,000, the additional money would be spent on improving, perhaps, link 7-24 from its second class condition in Figure 24 a to a first class condition, the program selects instead 23-33 as a new first class road in Figure 24 b. This result is correct and derives from the fact that the second class roads are very cost-effective (in terms of price change per construction dollar) to build. Consequently, even though 7-24 had rather weak node weights associated with it (weak compared to 23-33, to judge from the result of Figure 24 b), the construction money spent on it (in Figure 24 a) was very modest in comparison to the economic gain achieved. This kind of decision is of course the same kind made by a good human analyst: the program does not intend to do anything qualitatively different or better; the

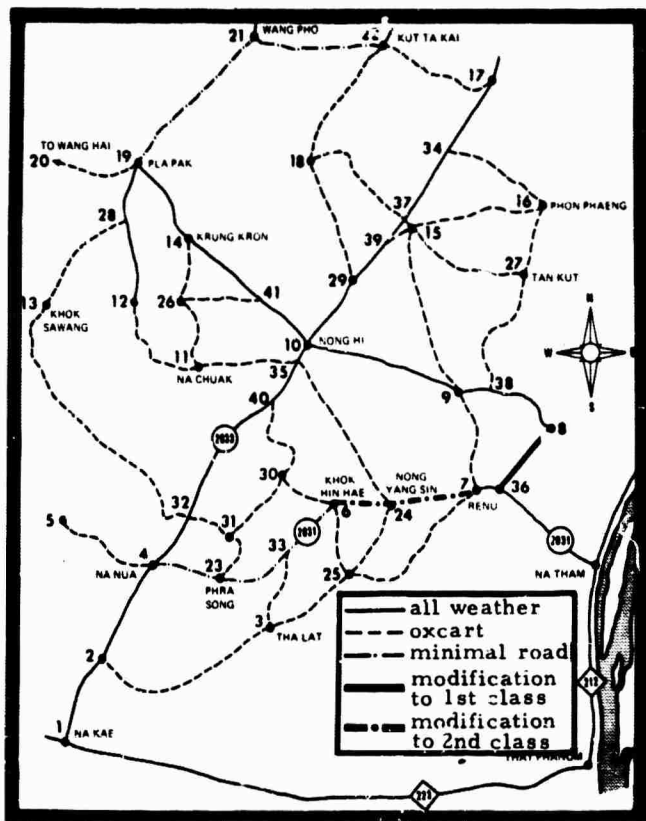

Figure 23. Road Improvements Chosen by Economic Model: Budget = \$10,000 per Year.

program only forms a practical way of correlating a decision problem involving a number of variables impossibly large for a human analyst to handle. Figure 25 shows the percentage price level change produced by the various road construction budgets. The price level is rather heavily dependent on the construction of the 8-36 segment in the model calculation because point 7 was taken as an entry port having very poor initial connections with the interior nodes; therefore the bar graph shows only small additional increases as long as 8-36 is modified to first-class.

The framework of the road construction model can also be adapted to special cases, such as the installation of a power plant or other important economic feature. That is, one could introduce a tradeoff between the value of the construction of a road to an isolated power plant and the value of the construction of a general multi-purpose road; mixed cases of this type can also be considered.

The economic road construction model does not treat the choice of vehicle inventory explicitly; the choice of vehicle enters only indirectly in that the model assumes there will be a tendency to use the most cost-effective vehicle possible on a given roadway. This assumption may be somewhat faulty in an economically limited environment; in compensation, however, one must realize that it is rather difficult to determine the cost-effectiveness of oxcarts as employed in a

Table 10. Cost-effectiveness (tons/\$) of region's road segments in units of the cost-effectiveness of one kilometer of oxcart trail (i. e., EC of 15-39, $l = 1$ km. is 1.00). Ratio of CE by classes taken as 1:2:3 = 24:4:1 (See Appendix H). When added together (by series capacitor law) for simulated shipments, these give relative probabilities of use of alternate routes.

Route	Cost Effectiveness	Route	Cost Effectiveness
1-2	6.00	14-26	0.370
2-3	0.114	14-41	5.72
2-4	6.00	15-16	0.161
3-25	0.330	15-27	0.167
3-33	0.345	15-39	1.00
4-5	0.204	16-27	0.345
4-23	1.48	16-34	0.200
4-32	8.57	17-22	0.125
6-24	0.435	17-34	6.32
6-25	0.345	18-22	0.159
6-30	0.322	18-29	0.178
6-33	1.05	18-37	0.178
7-9	0.208	19-20	0.0723
7-24	0.337	19-21	0.494
7-25	0.133	19-28	9.59
7-36	24.0	21-22	0.833
8-36	0.330	23-31	0.370
8-38	5.46	23-33	1.25
9-10	3.20	24-25	0.227
9-15	0.133	24-35	0.123
9-38	18.5	26-41	0.322
10-29	7.74	27-38	0.167
10-35	20.0	29-39	9.59
10-41	8.06	30-31	0.200
11-12	0.200	30-40	0.200
11-26	0.330	31-32	0.400
11-35	0.217	32-40	3.20
12-28	6.42	34-37	6.48
13-28	0.179	35-40	16.0
13-32	0.0769	37-39	20.0
14-19	5.00		

cash-poor economy. This question is, of course, worthy of further study; certainly, field investigations of actual markets would be useful.

The model as shown could be used in a staging or "dynamic" economic model. The need for a dynamic model comes about because, after the construction of an actual new road, the economy of points near the road would change. In our model, the "node weight" would be altered. These new "weights" would have to be inserted in the ECON-ILP program before new road-building decisions are made. The simulation would then involve one construction calculation with the initial economic conditions, the forecast of the new economic conditions, another construction simulation taking those new conditions into account, and so on. The calculation could be carried through many (simulated) years; the advantages for long-term planning are obvious.

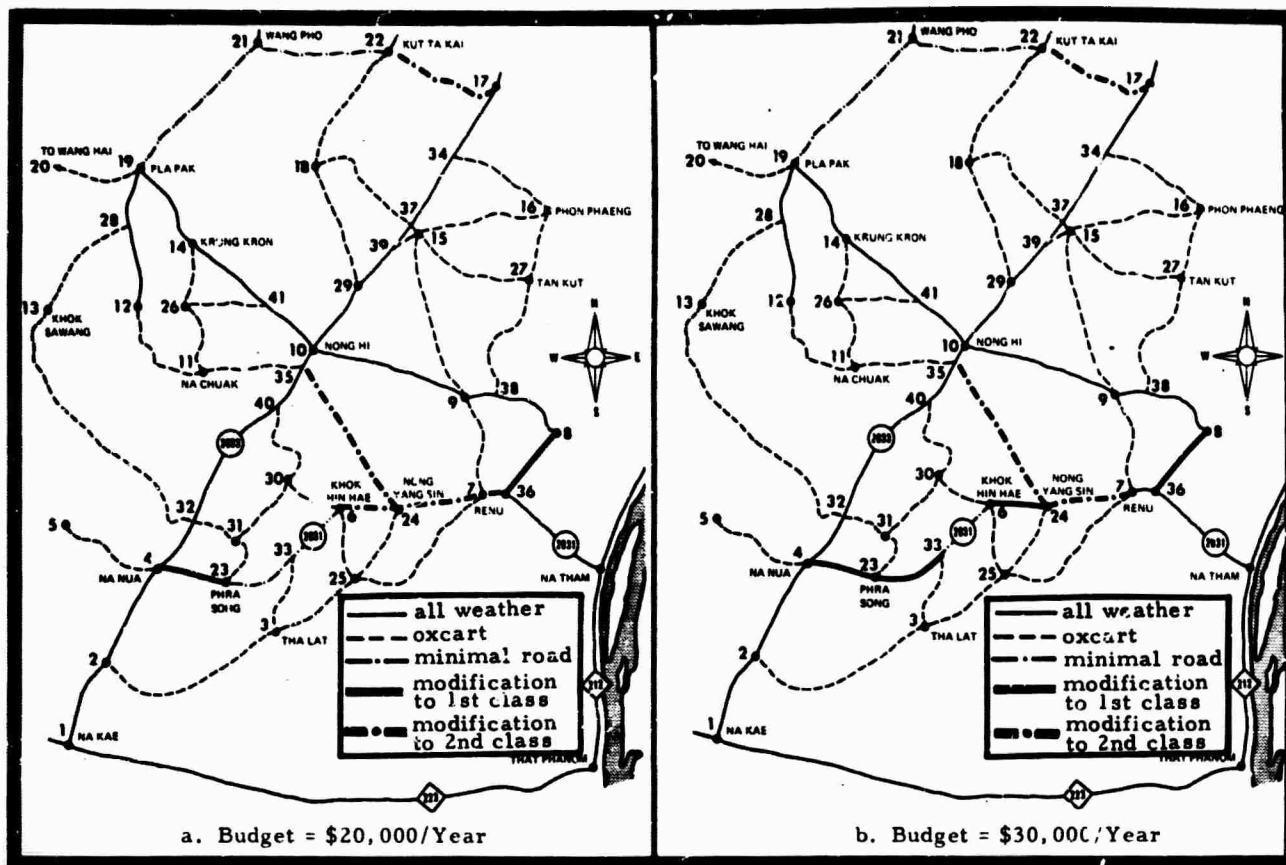

Figure 24. Road Improvements Chosen by Economic Model

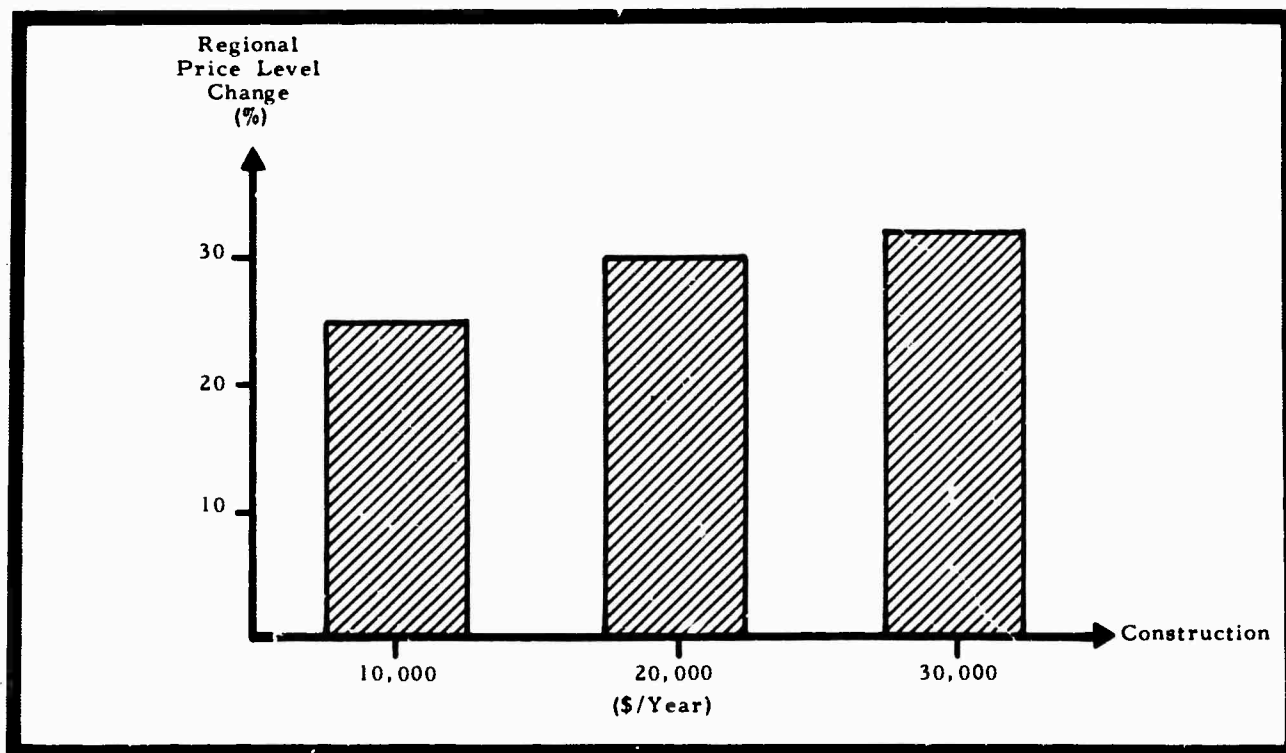

Figure 25. Percentage Reduction in Regional Price Level (average transport cost) produced by construction program for various budgets.

Table 11. "Segment Factors", given in terms of their coefficients for each "node weight". When each column is multiplied by the corresponding weights shown in the map (Figure 22, and the resulting columns of each row added together, the sum is the relative importance of the (row-numbered) road segment in determining the regional price level. N. E. Blank entries indicate negligible coefficients; node 28 is a junction, having zero weight.

Segment	Nodes														
	16	17	18	19	20	21	22	23	24	25	26	27	29	30	31
1-2	.363	.762	.273	.386	.353	.400	.380	.580	.361	.425	.379	.405	.283	.498	.650
2-3										.093					
2-4	.363	.762	.273	.386	.353	.400	.380	.580	.361	.332	.379	.405	.283	.498	.650
3-25										.228					
3-33															
4-5															
4-23								.937	.502	.615				.430	.661
4-32	.365	.762	.273	.386	.353	.400	.380	.357	.337	.283	.379	.405	.283	.448	.677
6-24								.063	.416					.084	
6-25									.086	.480					
6-30														.405	
6-33								.063	.502	.480				.321	
7-9															
7-24								.063	.327	.140				.084	
7-25										.152					
7-36	.417	.238	.246	.114	.286	.188	.199	.088	.264	.111	.211	.208	.067	.162	.261
8-36	.417	.238	.246	.114	.286	.188	.199	.088	.264	.111	.211	.208	.067	.162	.261
8-38	.323	.238	.246	.114	.286	.188	.199	.088	.264	.111	.211	.208	.067	.162	.261
9-10	.342	.238	.246	.114	.286	.188	.199	.088	.264	.111	.211	.248	.067	.162	.261
9-15															
9-38	.342	.238	.246	.114	.286	.188	.199	.088	.264	.111	.211	.248	.067	.162	.261
10-29	.417	1.00	.761		.361	.412	.475	.269	.248	.172	.410	.349	.350	.256	.538
10-35	.363	.762	.273		.353	.400	.380	.357	.312	.283	.379	.405	.283	.418	.799
10-41				1.00	1.00	1.00	.548				1.00				
11-12															
11-26															
11-35															
12-28															
13-28															
13-32															
14-19				1.00	1.00	1.00	.548								
14-26											.540				
14-41				1.00	1.00	1.00	.548				.540				
15-16	.325												.114		
15-27	.066												.284		
15-39	.391												.494		
16-27	.235												.366		
16-34	.440												.252		
17-22			.235				.299								
17-34	.314	1.00	.300	.500	.361	.412	.258	.269	.248	.172	.410	.397	.650	.256	.538
18-22			.148				.153								
18-29			.382												
18-37			.383				.153								
19-20				1.00											
19-21					1.00	.548									
19-28															
21-22							.548								
23-31														.109	.661
23-33								.063	.502	.480				.321	
24-25									.086	.140					
24-35									.171						
26-41											.460				
27-38												.264			
29-39	.517	1.00	.683	.500	.361	.412	.475	.269	.248	.172	.410	.349	.650	.256	.538
30-31														.227	
30-40														.368	
31-32														.118	.788
32-40	.363	.762	.273	.386	.353	.400	.380	.357	.337	.283	.379	.405	.283	.330	.799
34-57	.378	1.00	.400	.500	.361	.412	.258	.269	.248	.172	.410	.384	.650	.256	.538
35-40	.363	.762	.273	.386	.353	.400	.380	.357	.337	.283	.379	.405	.283	.418	.799
37-39	.378	1.00	.683	.500	.361	.412	.475	.269	.248	.172	.410	.384	.650	.256	.538

Table 11. (Cont'd)

Segment	Nodes														
	1	2	3	4	5	6	7	8	9	10	11	12	13	14	15
1-2	1.00	.146	.459	.736	.413	.415	.483	.386	.328	.523	.370	.390	.475	.418	.328
2-3			.158												
2-4	1.00	.854	.301	.736	.413	.415	.483	.386	.328	.523	.370	.390	.475	.418	.328
3-25															
3-33			.842												
4-5					1.00										
4-23			.702				.835								
4-32	1.00	.854		.264	.587	.138	.483	.386	.328	.523	.370	.390	.475	.418	.328
6-24			.140			.165									
6-25															
6-30															
6-33			.140			.835									
7-9								.086							
7-24			.140			.165									
7-25															
7-36	.222	.175	.151	.051	.220	.138	1.00	.144	.142	.134	.242	.130	.206	.112	.190
8-36	.222	.175	.151	.051	.220	.138	1.00	.144	.142	.134	.242	.130	.206	.112	.190
8-38	.222	.175	.151	.051	.220	.138	1.00	.856	.142	.134	.242	.130	.206	.112	.190
9-10	.222	.175	.151	.051	.220	.138	1.00	.856	.772	.134	.242	.130	.206	.112	.128
9-15															.062
9-38	.222	.175	.151	.051	.220	.138	1.00	.856	.142	.134	.242	.130	.206	.112	.190
10-29	.778	.679	.250	.213	.367	.282	.517	.470	.444	.343	.388	.480	.319	.470	.456
10-35	1.00	.854		.264	.587	.138	.483	.386	.328	.523	.467	.390	.315	.418	.328
10-41											.613	1.00	.840	1.00	
11-12											.325				
11-26											.183				
11-35											.387				
12-28											.325	1.00			
13-28													.840		
13-32													.160		
14-19											.325	1.00	.840		
14-26											.183				
14-41											.508	1.00	.840	1.00	
15-16															
15-27															
15-39															.938
16-27															
16-34															
17-22															
17-34	.778	.679	.250	.213	.367	.282	.517	.470	.444	.343	.388	.480	.319	.470	.482
18-22															
18-29															
18-37															
19-20															
19-21															
19-28											.325	1.00	.840		
21-22															
23-31															
23-33			.703			.835									
24-25															
24-35															
26-41											.105				
27-38															
29-39	.778	.679	.250	.213	.367	.282	.517	.470	.444	.343	.388	.480	.319	.470	.456
30-31															
30-40															
31-32															
32-40	1.00	.854		.264	.587	.138	.483	.386	.328	.523	.370	.390	.315	.418	.328
34-37	.778	.679	.250	.213	.367	.282	.517	.470	.444	.343	.388	.480	.319	.470	.482
35-40	1.00	.854		.264	.587	.138	.483	.386	.328	.523	.370	.390	.315	.418	.328
37-39	.778	.679	.250	.213	.367	.282	.517	.470	.444	.343	.388	.480	.319	.470	.482

Table 12. Road modification calculation parameters. Budget requirement (amortized cost, including maintenance) for road upgrading as shown. Predicted percentage change in consumer price levels in area. (N. B. Decision model depends only on ratios of values of these parameters.)

Route	Road Class Modification	Budget Requirement Modification Cost/Year	Predicted Price Level Change (%) Produced by Modification
4-23	2 → 1	\$ 5100	% 1.72
6-24	3 → 2	650	0.78
6-24	3 → 1	4990	0.99
6-33	2 → 1	7170	0.98
7-24	3 → 2	1075	1.33
7-24	3 → 1	8250	1.70
8-36	3 → 2	1045	18.3
8-36	3 → 1	8030	23.3
17-22	3 → 2	2260	3.15
17-22	3 → 1	17400	4.01
19-21	2 → 1	15300	2.59
21-22	2 → :	9060	0.80
23-33	2 → 1	6030	0.96
24-35	3 → 2	2290	0.27
24-35	3 → 1	17600	0.35

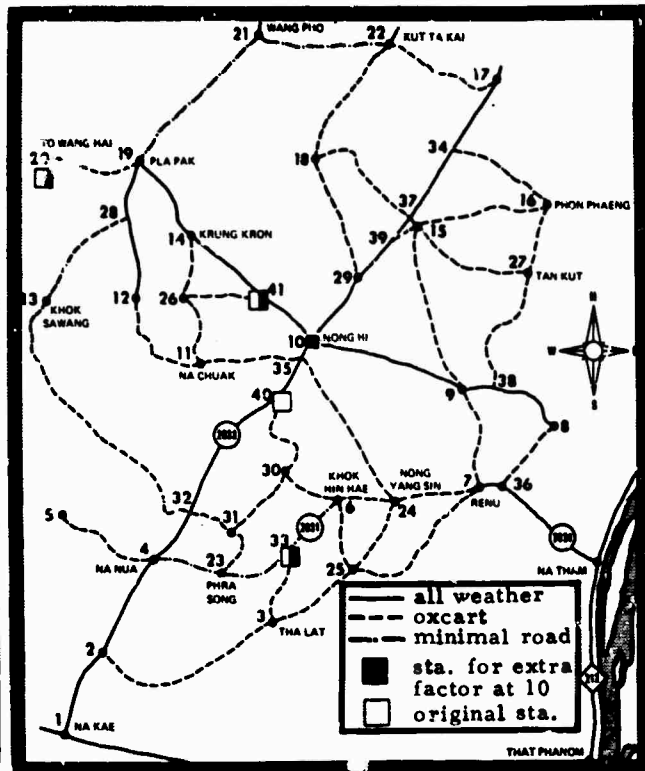

Figure 26. Security stations with added socioeconomic factor: ROTE vehicle travel, wet weather. $T_R = 1.00$ hour.

The Interaction between Security and Socio-economic Considerations

The effects of transportation system changes made for security reasons on the economic sector, and of those made for economic reasons on the security sector, are of prime concern to the planner. In a sense, the effect of economic changes on security requirements is already implicitly treated in the NETSIM reaction time and stationing program. That is, the possibility of restricting supply (security) stations to certain points of the network has already been considered (viz. Figures 15 and 18); the reason for such restrictions could well be of a social or economic nature, as suggested before. One can show this option explicitly by an example. Consider that a hospital has been established at node 10 (Nong Hi). The security problem might now require that this hospital must be protected by a security station at node 10. Where must the other stations be placed for given reaction times, vehicles and roads? The answer to this sample problem is shown in Figure 26 (for ROTE vehicles in wet weather). The solution with the hospital requirement has the same number of stations as the problem without (taken from Figure 16 a), but now one station is constrained to be at point 10. It is a feature of the program that solutions of this sort, where particular station locations can be specified without extra cost, can be found (if in fact such solutions do exist in the particular case).

As a somewhat more complicated interaction of security and economic needs, one can consider the solution to the ECON-ILP road building simulation program shown in Figure 23 (budget of \$10,000/year). The program in this case recommended modifications in routes 8-36, 6-24, and

7-24. Since these routes will have the greatest effect on the security problem in the southeast sector of the region, it is most illustrative to solve the security problem for that region alone (jeep, set weather), obtaining the solution shown in Figure 27a. (Samples of the actual computer runs for this case are given in Appendix). For reaction time, $T_R = 0.60$ hour, we obtain a five-station solution; for a reaction time, $T_R = 0.85$ hour, a two-station solution. Then one examines the same security problem, but now including the road modifications recommended by ECON-ILP. The result is shown in Figure 27 b: only four stations are needed for $T_R = 0.60$ hour and only one station for $T_R = 0.85$ hour. The tradeoff of total expense, security and economic, is shown for both reaction times, using the sample costs considered before, in Figure 28; the result indicate, the possibility that some of the economic development is "free".

The converse problem, that of the effect on the economy brought about by roads built for security reasons, can be illustrated by taking, for example, the situation shown in Figure 17, where the improvement of links 26-41, 15-39 and 15-27 has eliminated the need for one security station (node 38). The resultant predicted price level (or average transport cost) change given by the ECON-ILP parameters is 2.3%. This economic prediction would be useful to the road planner in comparing routes 15-27, 15-39, and 26-41 with other routes which were equivalent to them in usefulness as far as security is concerned; the economic model could then serve as a criterion for resolving ambiguous security judgments.

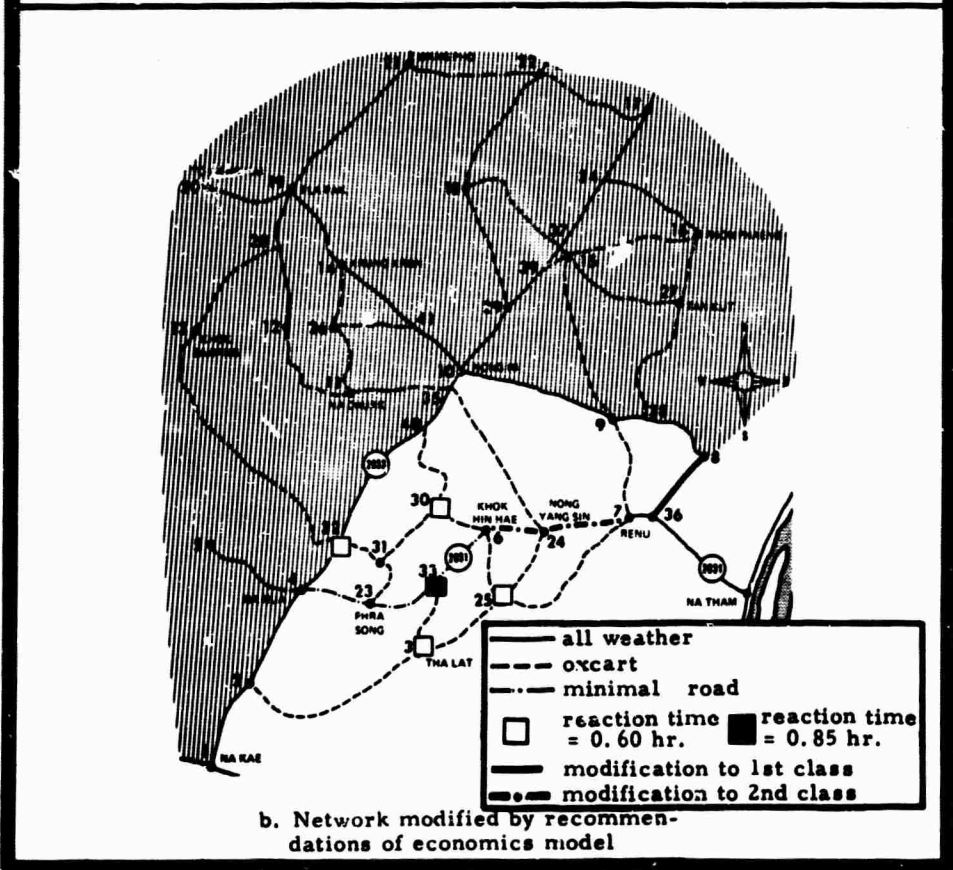
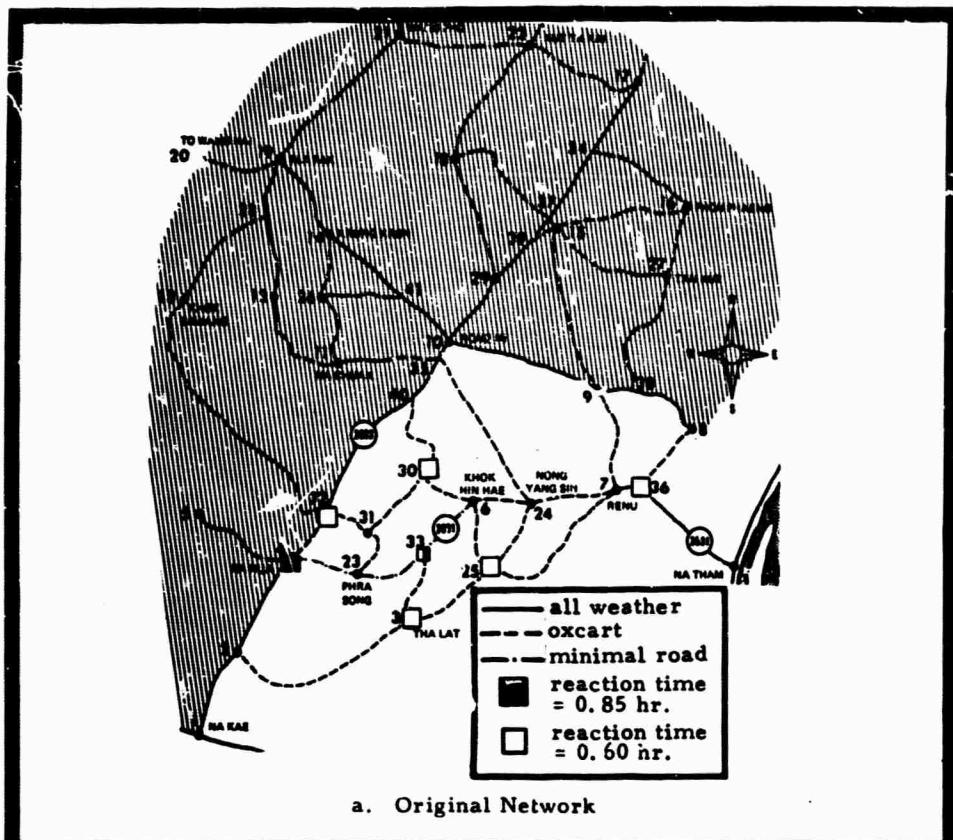

Figure 27. Security stations requirement reduced by economics-oriented road construction - jeep, wet-weather travel with security demand in southeast sector only.

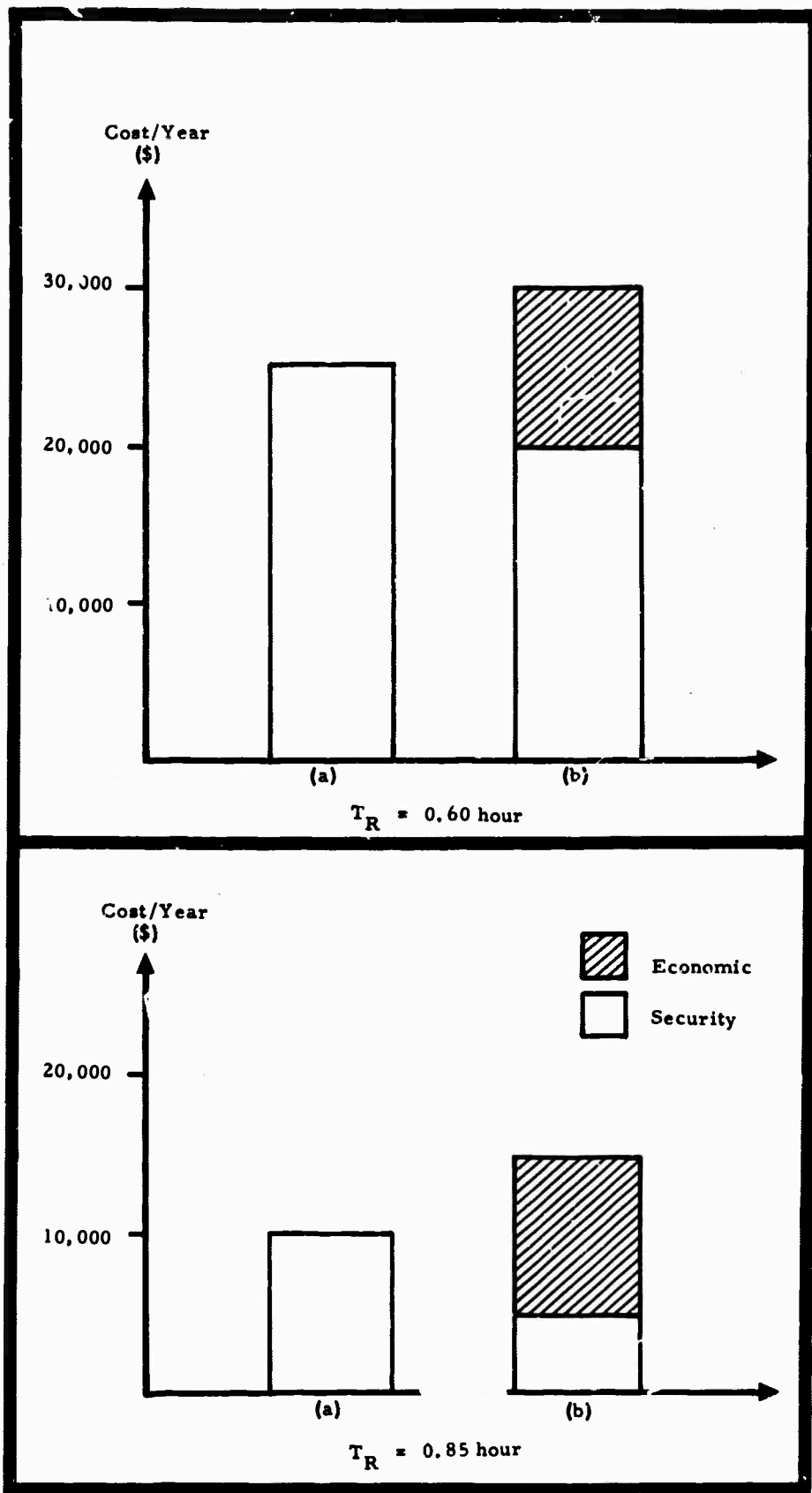

Figure 28. Costs of stationing and road-building for the cases of Figure 27.
 (a) original network
 (b) economics-oriented network modifications

THE DATS PROGRAM PLAN

The DATS program can be logically divided into four phases as shown in the block diagram (Figure S-6) in the summary section of this report.

- Phase 1: Conceptual Study
- Phase 2: Definition and Design
- Phase 3: Verification - Pilot Study
- Phase 4: Total Transport Plan

PHASE 1: CONCEPTUAL STUDY

The report on the study carried out under contract to ARPA-Agile describes the work of Phase 1. This phase developed methods for reducing quantities of data to manageable form by abstracting the critical elements of a transportation system. These critical elements were then organized into a framework for a general transportation simulation model ("SIMDATS"). This framework was subsequently tested by developing two specific simulation computer programs, the NETSIM model for treating a number of military problems, and the ECON-ILP program for simulating economic improvement through road construction.

PHASE 2: DEFINITION AND DESIGN

The program carried out in Phase 1 constructed a framework for the rational development of a systems-oriented transportation plan. Phase 2 should proceed to strengthen and fill in that framework to develop a complete structure for a simulation-aided systems analysis. That is, the study in the first phase aimed at separating out just the indispensable elements of a transportation system and then testing the formulation of these elements on several instructive examples of simulation-aided decision-making. The second phase, however, should be directed toward increasing the number of key elements treated so that real-world decisions can eventually be made; in addition, simulations should be developed for a wide range of possible planning decisions, and the general systems analysis expanded to provide firm guidelines for any future programs.

The fields of study in Phase 2 can be divided into two groups, means of transportation and needs for transportation.

Means

The means of transportation are usually considered under various conventional categories; in each category, one can treat various subsystems.

Categories

The role of transportation in developing areas has usually involved road transport; and, indeed, road transport was the major topic of interest in the Phase 1 study. Road transport, after all, in the form of foot or primitive vehicle movement, is the most common form of transportation in subsistence economies, and improvement of roads is perhaps the most direct way of aiding such regions to evolve economically. It must be considered, however, that water transport, if only by dugout canoe, constitutes a basic mode in many areas. In addition, the growth of counterinsurgency requirements in many regions has made necessary the introduction of air transport into regions where lack of capital and markets would make such introduction unlikely on a purely economic basis. Indeed to comment on the situation in Northeast Thailand, study reports made ten years ago recommended the abandonment, as uneconomic, of many airfields which then existed. Would such a recommendation be valid today, when security requirements for meeting outbreaks of insurgency have made air transport of vital importance?

It could be argued that "air transport" in this case might be primarily helicopter transport, this not invalidating the older planning conclusions; or it might be said that helicopter transport, while suited for military needs, is unsuited to the economic needs of the people of the area. The purpose of these comments is not to answer such questions, but merely to indicate that they exist, and that such questions must be treated and answers derived by the methods of systems analysis if the work of Phase 2 is to have any usefulness for planning.

In general, therefore, although road transportation may be the focal point of a developmental program, air transport may have to be considered, especially in areas where modern military procedures have been introduced. Furthermore, using Northeast Thailand again as an example, development in areas bordering the Mekong River will necessarily involve the role of water transport.

The building of railways is perhaps oddly enough, one of the most difficult to include in the analysis, if only because their high capital cost and dependence on large quantities of freight for economic operation may well make them an option not

available to the actual planner. The inclusion in the study of rail transport per se may well hinge on what political limits are envisaged as being placed on the planner. The inclusion of railways as an existing factor, however, cannot be neglected, as indicated by recent studies on the effect that existing railway stations have had on the economic consequences of the Pitsanulok-Bangkok highway in north-central Thailand. Indeed, the interaction of the termini of other categories of transportation (airports, railway stations, ports) may be a key element in any meaningful systems analysis of a road network in an emerging region.

Subsystems

If one considers the road network as the "system", then the roads, vehicles, and personnel who operate and maintain the vehicles can be considered "subsystems". Some of the areas of study connected with these subsystems are considered below.

Roads. One of the results of the Phase 1 work might be with some exaggeration, summarized as an assertion that roads, by themselves, are not very interesting objects. Transportation always involves the vehicle-road combination, so that from a systems point of view, the combination is the important factor. Nevertheless, in practice, a given road must allow for many kinds of vehicles, from men on foot to semi-trailers, so that there is some logic in considering the road itself as a viable subsystem. In Phase 1 calculations, this subsystem was calibrated with the overall system by examining the costs and times associated with the road for the most cost-effective vehicle (economic) or fastest vehicle (military).

The vagaries of differing travel times and transport costs on what are usually considered complete roads or routes were treated in the SIMDATS program by dividing the route into segments and assigning a constant, averaged time (or cost) to each segment. This procedure essentially amounts to an elaboration of the usual division of roads into "classes"; it should be noted, however, that a narrow bridge, for example, or a stretch of winding road constitutes a segment of its own, with its own "class" in the model used. In addition, this SIMDATS incremental model supposed that changing weather conditions changed the "class" of the road. This treatment was applied with what seems intuitively reasonable results to the particular problems solved, and it is recommended here that such a framework be retained for the Phase 2 work.

If the framework of the incremental model appears sound, however, the application of this model to real (as opposed to realistic) situations would demand a much more fine-grain treatment: in the examples considered, the number of dry season classes considered were only three. Certainly more elaboration is indicated.

The problem of off-road mobility could not be considered in depth in the Phase 1 study because of lack of reliable data. Useful experimental data on such mobility is, indeed, very limited; and if the need for this category of movement is adjudged great, a major effort in research and technology is needed in Phase 2.

The "minimal road" concept (described in the Battelle Memorial Institute Report RACIC-TR-59) appears, from the results of the Phase 1 study, to be worthy of further consideration. Phase 2 investigation into this program (spending relatively small sums on road construction and large sums on vehicles) might be carried out from the roadway point of view, with an eye to the use of new types of roadbed materials.

Somewhat related are concepts of vehicles which carry along their own roadbeds, in the form of detachable tracks or other devices. Certainly there is room for consideration of such technological innovations for use in developing areas.

Vehicles. The SIMDATS model provides a quite general framework for the handling of all types of vehicles, as they "interact" with roads to provide transport under all kinds of conditions. The work of Phase 2 should consist in gathering reliable data for as many different types of vehicles as are thought desirable to make possible the setting up of a large, multidimensional matrix of velocities and costs. The choice of roads will, of course, be dependent on the choice of vehicles; for example, the minimal road concept requires the consideration of ROTE (Rolligon bag or Terratire Equipped) vehicles. In addition, local custom or existing vehicle inventories may dictate that samplers or oxcarts be considered together with the usual mix of cars, busses, and trucks. As with roadbeds, technological progress may make possible the introduction of more-or-less exotic vehicles or vehicle modifications.

Maintenance. The study of costs of maintenance, both of roads and vehicles, would be an important task of Phase 2. The general structure, at least, of the road maintenance task is relatively patent: maintenance costs for roads in developed regions are fairly well-known, and the direction which data collection should take for developing areas is reasonably clear. Vehicle maintenance, however, is a rather more difficult problem. Auto parts must usually be brought from abroad and transported long distances to the maintenance location; the personnel used (as discussed in the next section) must be skilled; maintenance stations must be "correctly" placed in the presence of sometimes obscure economic constraints, and so on. The systems analysis of the problem seems to require the equivalent of some kind of research study or experimental program. Perhaps the pilot study of Phase 3 would be useful in this regard.

Personnel. All of the subsystems described above require some consideration of personnel. The road construction problem, for example, might typically require large numbers of untrained workers and small numbers of highly-trained personnel. The desirability of using these large numbers of workers might be well-established regions where the marginal product of labor is zero, hence the choice between either importing the highly skilled workers and equipment or setting up intensive local training needs evaluations. Similarly, the training of mechanics for vehicle maintenance would present complicated cost problems; it has been observed, for example, that trained personnel can be lost to maintenance careers if socioeconomic pressures interfere. Such questions require careful formulation in Phase 2, but probably only a pilot study can produce reliable conclusions.

The problem of driver ability (and stability) is of course a difficult one. The first link in the man-machine-road system is perhaps the most difficult to quantify. The importance of driver skill in system efficiency is, of course, critical in off-road mobility problems. For on-road operation, the driver factor, though least amenable to exact determination, can probably be safely confined within certain quantitative limits. Part of the task of Phase 2 would be to check this last supposition by investigation of commercial driver performance in, for example, a region of suitable size in Northern Mexico.

Needs

The transportation system exists to fill certain needs of population of the region; this section considers how those needs should be studied in Phase 2 of the DATS program. The needs can be divided into the three parts considered in Phase 1: security needs, socioeconomic needs, and security-socioeconomic interaction; in addition, a fourth part, called "socioeconomic feedback" is also considered, to deal with roughly the changes effected by the transportation system on the economy.

Every region needs some kind of security structure, if only the usual protection afforded by a system of police stations. In addition, the presence of acute social problems and concomitant insurgent movements have made the development of paramilitary security systems essential for the stability of many emerging regions. This conclusion, moreover, in the present state of economic distributive imbalance, is probably independent of political ideology or forms of power.

Model calculations in Phase 1 have shown how transport simulation can be used to solve a restricted (but, hopefully, important) class of security problems, that is, those involving allocations of security forces. It is rather straightforward to see that such techniques can be adapted

to problems of patrols, ambushes, alarm systems, and so on. One extension of the work especially needed in Phase 2 is a more exact determination of insurgent patterns (their dependence on geography, terrain, agricultural cycles, and so on) from studying the experience of countries such as Greece, Bolivia, and Vietnam, so that the location and timing of probable insurgent incidents can be incorporated into the simulation. Another recommended task for Phase 2 is the detailing of various likely tactical plans for meeting outbreaks of insurgency. Admittedly, this last is an area of great uncertainty; nevertheless it seems likely that, in addition to existing research studies, consultation with experienced military personnel might help in the development of reasonable tactical alternatives for the simulation.

Socioeconomic Needs

The expression "socioeconomic needs" is taken to represent all needs for transportation which are not principally concerned with security requirements; governmental centers, health organizations, educational institutions, as well as agriculture and industry figure in this category. The approach of the Phase 1 study has been to try to establish one overall socioeconomic "weight" for each node of the network and to evaluate transportation requirements as proportional to these "weights" (or priorities). This procedure may be held to constitute a severe abstraction from reality; yet it may be seen to be a reasonable mode of analysis, at least as far as a first-order approximation scheme is concerned. Certainly such a scheme can encompass special needs in special areas; and, since the basic SIMDATS format has the ability to handle seasonal changes, such problems as that of harvest-time agricultural needs can be easily included. Part of the task of Phase 2 would logically be the construction of a framework for handling these special cases.

One of the particular simulations worked out in Phase 1 computed recommended road improvements for given economic situations. The extension of this model to more realistic applications is suggested. Part of what is necessary to refine this model is implicit in the road-vehicle discussion: a better knowledge of road construction, and maintenance costs, and better data on the cost-effectiveness of certain vehicle-road combinations. Another part of the refinement of the model could involve the economic "weights" themselves. Certainly the balancing of, say, population density with industrial activity, the latter with rice production, and so on, to arrive at an economic weight which will describe relative traffic flows is a difficult process. It is not proposed here to derive a "magic formula" for such a complex feature. One can however, validate an empirical formula of this kind by making a statistical study of economic factor measurements versus traffic flow data, using some region where economic development is relatively uncomplicated, but where also statistical accuracy and completeness is probably of high

order, for example, say, the Canadian province of Manitoba.

The economic simulation, as developed, was designed particularly for situations where road usage was an unknown quantity; even if present road usage is known, however, future road usage patterns may differ greatly, especially for emerging regions. Nevertheless, the gathering of any statistical data available on road usage and a comparison of that usage with the "simulated usage" of the model would be a useful Phase 2 activity.

The role of decision-making in the economic transportation model need not, of course, be confined to choices of road construction, or even of decisions on the planning of road-vehicle combinations; the placement of maintenance facilities is also only a small part of the total economic task. For, if the goal of the system is to be economic expansion, the interaction of transportation improvement with other economic improvements must necessarily be considered. For example, the introduction of utility lines or irrigation ditches is often facilitated by combining those activities with road construction; separate planning in this case would certainly be very wasteful. Similarly the planning of a new hospital, say, might require the construction of a road to serve it; certainly, however, that road should also be planned so as to provide maximum benefits for areas along its route. One should note also the lamentable fact that the carrying out of agricultural improvement schemes (pest control, seed improvement, crop rotation) may raise the value of agricultural land in some areas so much that great sociopolitical and economic pressures are created against the use of land for roads. (Cases of reversion of road to rice paddy are certainly not unknown.)

A further task in Phase 2 might be a refinement of economic goals. The Phase 1 calculations took the economic goal to be reduction of transport costs with concomitant rise in per capita real income. The ECON-ILP formulation, however, recognized that the expenditure of wages in a zero-(real)-labor-cost economy must tend to increase local money prices. It was assumed there that, because of time lag in this inflationary process, the resulting increase in apparent consumer demand would result in stimulated production and imports of goods, thus raising real per capita income even more. Such assumptions could be studied, through statistical means, in the work of Phase 2.

It is also a question of interest whether or not the stimulation of exports from the region — a process which can be affected by choices of transport routes — is always beneficial to the local economy. The experience of Ghana, where a successful export trade in cocoa and minerals has been very beneficial to the rest of the economy, contrasts with that of Brazil, where the first successful steps toward self-sufficient growth appears

to have come from the deliberate discouragement of reliance on coffee exports, subject as coffee was to several fluctuations in world market prices, with resulting chaotic effects on the Brazilian economy. Complete answers to a problem such as this are undoubtedly too ambitious an expectation for Phase 2. Nevertheless, some bounds on such effects should be sought in thorough statistical analyses.

Interaction Between the Security and Socio-economic Areas

Phase 1 studies have examined the simulated effects of road construction for military purposes on the civilian economy, and of civilian road construction on military response times. In addition to improving this road construction model, a task of Phase 2 should be that of studying such topics as the double (civilian-military) use of vehicle inventories and the training of personnel for military purpose and the subsequent use of their talents for socioeconomic ends. Actually, however, the separation in the first place of security and socioeconomic into two separate categories would probably come to seem rather artificial if the work of Phase 2 is carried out in sufficient detail. The interaction of security needs with, say, agricultural needs would be on the same logical footing as the interaction of agriculture with industry. All of these categories could be identified by separate parameters, but the intertwining of needs would become an inescapable whole, a result to be expected in a "systems" analysis.

Socioeconomic Feedback

Properly speaking, "socioeconomic feedback" is not a separate category of study; such questions inevitably arise both in the security and economic fields as they have been considered before. It is worth emphasizing, however, that one of the greatest difficulties with long-range planning is the fact that the parts of an overall plan which have been carried out change the environment for which the plan was made in the first place. This environmental change is socioeconomic feedback; and one of the great virtues of the simulation approach is that one can simulate, for example, the construction of roads, then simulate the growth of new industries as a result of those roads, and then the road construction simulation can be applied again, to derive new planning recommendations based on the simulated new industries. This is not to say that accurate "staging" simulations of this kind are easy to handle; indeed, it should be one of the principal tasks of Phase 2 to create models sufficiently accurate to do this kind of analysis. It is probably true that data on this question are available, but that the difficulty of dealing with this feedback data without mathematical aids and high speed computers has discouraged use of this data by planners: such discouragement is no longer justified.

This feedback, of course, does not deal with just the development of new industries; indeed, "social" factors may be of paramount importance. As just one example, consider the effect of making remote roads in Northeast Thailand passable in the wet season. The whole fabric of peasant life there is probably dependent on a wet season - dry season oscillation of activities; the situation might be analogous to that in a farm community in North Dakota if winter were suddenly "turned off". Such examples must be legion, and the conclusion can be drawn that this part of Phase 2 might contain many unexpected features.

Timing

The time allotted to complete the work of Phase 2 should be about 15 months.

PHASE 3: VERIFICATION-PILOT STUDY

Phase 3 of the DATS program should be a pilot study to validate and correct the parameters derived in Phase 2. This validation should consist of actual operations in the field, in which various improvements in transportation are carried out to test the extent to which the results of these real-life improvements check with results predicted by the simulation model. Phase 3 should not begin until substantial progress has been made in Phase 2, since the detailed form of the pilot operations depends on the exact structure of the simulation models and planning framework setup during that phase. From the vantage point of the end of Phase 1, however, some kind of forecast can be made of likely pilot program operations. Some of the studies which might be carried out are:

Vehicle-Road Studies

Time Tests

Experiments on the actual travel times of various vehicles on various classes of roads would be needed to determine accurately the parameters of the incremental model.

Mobility Tests

If off-road mobility is judged to be an important consideration in the overall transportation plan, then tests similar to the "Mudlark" series in Thailand, but perhaps performed under somewhat different procedures would have to be carried out to test the operation of wheeled and tracked vehicles in various types of terrain.

Costs

The actual costs of conventional vehicle operations should be determined in order to gauge the economic consequences of changing various transportation parameters. This type of test

should be combined with the maintenance pilot study discussed below.

Minimal Road Studies

The "minimal road" concept - that of combining limited roadway clearing and grading operations with the use of special low-ground-pressure (ROTE) vehicles - would be a likely candidate for field testing, if the cost of such tests is not excessive. The true costs of operation of "minimal" systems must be studied carefully; in particular, possible maintenance problems must be considered.

Conventional Road Construction

From both the military and socioeconomic points of view, certainly the most straightforward, useful (but perhaps most expensive) kind of pilot study which could be carried out is the building of conventional roads in one area and the building of security efficiency and economic advancement in that area to that in a control area. Since the effects would undoubtedly be beneficial, the cost of such "tests" could be written off in part to surefire permanent economic improvement.

Traffic Tests

Conventional traffic counts would be one of the cheapest ways to gather useful field data. With care in selecting control regions, much information on economic road-building simulation parameters could be gained.

Maintenance Studies

Vehicle Maintenance

The cost of establishing and operating vehicle service repair stations in various localities could be studied, perhaps in connection with the personnel experiments mentioned below. A useful experiment would be to compare the operation of repair garages at model-determined locations on busy highways, with similar operations in large cities as related to strict cost-effectiveness plus general social feedback benefits.

Road Maintenance

The effects of road maintenance by very labor-intensive means compared to that by relatively capital-intensive means could be compared. Presumably, in under-employed economies, the labor intensive method is most efficient; the feedback effects of increased money wages into the economy, however, would be a matter of great interest for the refinement and validation of economic models.

Personnel and Training

Driver Studies

The effect of driver skill and social custom involving on and off-road mobility would be of interest; tests comparing relatively skilled and

unskilled vehicle operators would be a natural choice for study.

Repair and Maintenance Personnel

The problems of training personnel for skilled auto and road maintenance work could be treated by instituting special vocational programs to develop such skills. The graduates of such programs could be compared against other skilled personnel as far as their total social and economic effectiveness is concerned. The effect of cultural inhibiting factors could be considered.

General Socioeconomic Experiments

Other Capital Expenditures

The correlated introduction of economic projects, such as irrigation systems, with road construction could be compared for effect with the uncorrelated introduction of either alone.

Education and Propaganda

The effect of education on encouraging greater use of transport facilities could be tested, for example, by the use of propaganda to advocate travel from remote areas to large cities, perhaps including a scheme for a subsidized buses. Conversely, the role of roads in making possible attendance at literacy "clinics" or special agricultural education classes could be observed.

Other Tests

Only some sample possibilities have been mentioned for the planning of the pilot program. As mentioned above only after the work of the second phase is concluded can a full program for Phase 3 be planned. The role of the roads in health education and the building of roads to develop remote mineral resources, for example, has not been mentioned. From the point of view of Phase 1, however, one would tend to recommend for special attention vehicle speed tests (particularly those including seasonal effects) and the measurement of traffic flow on existing networks.

Timing

Phase 3 should begin about six months after the beginning of Phase 2 and last about two years. It is anticipated that close feedback between the two phases would continue until the end of Phase 2. Indeed, it might be considered desirable to continue some liaison effort in Phase 2 work until the end of Phase 3.

PHASE 4: TOTAL TRANSPORT PLAN

The results of the pilot study in Phase 3, applied to the systems framework of Phase 2, should yield the final values of simulation and systems parameters. Using these parameters, the complete Developing Area Transportation System plans could be drawn up. The DATS program would then be ready to proceed to carry out a large-scale planning operation for emerging areas; the data selection methods would be developed, and the simulation model constants would be determined. After the selection of a suitable region for development, data from the new region would be gathered and inputted, prospective plans would be tested on the simulation model and recommended optimal planning parameters would be read out. This procedure would, in effect, make available the results of study on previously examined regions to the planners of the new region, so that costly mistakes could be avoided.

Timing

Phase 4 should begin about two months before the conclusion of Phase 3 and last about eight months.

The total program, therefore, would require three years for completion.

**DEVELOPING AREA TRANSPORTATION
SYSTEMS STUDY**

III. APPENDICES

TABLE OF CONTENTS

APPENDICES

<u>Appendix</u>		Page
A.	SIMDATS PRELIMINARY TRANSPORTATION SIMULATION PROGRAM	
	Introduction	52
	Program Description	52
	Detailed Program Flow Charts	56
B.	TRANSPORTATION NETWORK CHARACTERIZATION	
	The Problem	75
	Determination of (T)	76
	Example	77
	Alternate Procedure	77
	Determination of Route	31
C.	THE SECURITY STATION PROBLEM	
	Basic Single-Need Problem	82
	Multiple-Need Problem	82
	Inclusion of Transport Costs	83
	The Integral Unit Problem	83
D.	ALLOCATION OF RESOURCES TO MINIMUM SUPPLY DEPOTS	
	Introduction	85
	Approach	85
	Example	86
	Computing Algorithms	88
E.	NETSIM COMPUTER PROGRAM DESCRIPTION	
	Introduction	90
	Program Summary	90
	NETSIM Executive Program Description	90
	Subroutine DYNAMIC Description	70
	Subroutine J STAR Description	90
	Subroutine TCHEV Description	95
F.	NETSIM PROGRAM CAPABILITY	
	Introduction	100
	Network Description	100
	Optimum Transit Times	101
	Optimum Routes	101
	Reachability	103
	Minimum Supply Node Solutions	105
	Discussion	114
G.	THE DEVELOPMENT OF ECONOMIC CRITERIA	
	Determination of Demand	115
	Optimization Goals	116

H.	THE ECØN-ILP MODEL	119
I.	DOCUMENTATION OF THE ECØN-ILP COMPUTER PROGRAM	
	General Description	122
	ILP-2 Program	122
	IL PUNCH Program	122
J.	OFF-ROAD AND PRIMITIVE ROAD MOBILITY: ROAD/VEHICLE FACTORS	
	Cone Index	126
	Vehicle Classification	127
	Trafficability Factors	128
	Soil Characteristics	128
	Terrain Features	133
K.	VEHICLE - TERRAIN EXAMPLE: A VELOCITY FIELD ASSIGNMENT CRITERION	134
L.	NOMENCLATURE	137
M.	REFERENCES	139

LIST OF ILLUSTRATIONS

APPENDICES

<u>Appendix</u>	<u>Figure Number</u>	<u>Title</u>	<u>Page</u>
A	1	SIMDATS Functional Flow	54
	2	Detailed Flow Diagram for MAP Subprogram	57-58
	3	General Flow Diagrams for Elemental Area Analysis Program	60
	4	Detailed Flow Diagram for Elemental Area Analysis Program	61-63
	5	Detailed Flow Diagram for Region Analysis Subprogram	64
	6	General Flow Diagram for Allocation Schedule Subprogram	65
	7	Detailed Flow Diagram for Allocation Schedule Subprogram	67-70
	8	Detailed Flow Chart for Segment Subroutine	72-73
	9	Detailed Flow Diagram for Dynamic Subroutine	74
B	1	4-Node Example	78
	2	Program Logic	79
	3	Simplified Program Logic	80
C	None		
D	1	7-Node Network Example	87
	2	Minimum Transit Time T	87
	3	Boolean \hat{T} matrices	87
E	1	NETSIM Program Summary	91
	2	Functional Diagram for Subroutine J STAR	92
	3	Typical Input Matrix	93
	4	Typical Output Matrix	94
	5	Functional Diagram for Subroutine DYNAMIC	95

<u>Appendix (cont)</u>	<u>Figure Number</u>	<u>Title</u>	<u>Page</u>	
E (cont)	6	Typical J STAR Printout	96	
	7	Functional Diagram for Subroutine TCHEV	97	
	8	Typical \hat{T} Printout	98	
	9	Typical Boolean Reduction Printouts	99	
	10	Typical Final Printout	99	
			100	
	F	1	Unsymmetrical 20-Node Network with Link Times	100
		2	Symmetrical 20-Node Network with Link Times	100
		3	Incremental Matrix (t)	101
		4	Optimum Matrix (T)	101
5		Matrix of Immediate Predecessor Nodes $J^*(I, K)$	102	
6		Optimum Routes from Node 10	103	
7		Optimum Routes Into Node 9	104	
8		Links Never Used on Optimum Routes	104	
9		Travel From Node 2	105	
10		\hat{T} Printout	106	
11		Sample Results for $T_R = 4$	107	
12		Solutions for $T_R = 4$	108	
13		Network Coverage by the [4] [18] Solution ($T_R = 4$)	108	
14		Network Coverage by the [4] [15] Solution ($T_R = 4$)	108	
15		Sample Results for $T_R = 3$	109	
16		Solutions for $T_R = 3$	110	
17		A Minimum Node Solution for $T_R = 3$	110	
18		Solutions for $T_R = 1$	110	
19		A Minimum Node Solution for $T_R = 1$	111	
20		The Unique Solution for $T_R = 2$	111	
21		Solutions for $T_R = 5$	112	
22		Triple Solutions for $T_R = 5$	113	
G	None			

<u>Appendix (cont)</u>	<u>Figure Number</u>	<u>Title</u>	<u>Page</u>
H	None		
I	1	ILP-2 Deck Setup	123
	2	IL PUNCH Deck Setup	123
	3	Sample Listings	125
J	None		
K	None		

LIST OF TABLES

APPENDICES

<u>Appendix</u>	<u>Table Number</u>	<u>Title</u>	<u>Page</u>
F	1	Number of Minimum Node Solutions	105
	2	Solutions to the 20-Node Symmetric Network	113
	3	Number of Nodes in the Minimum Node Solution	114
J	1	Examples of Vehicles and Characteristics	129-130
	2	Trafficability Characteristics of Soils in Wet Season	131
	3	Approximate Range of k-values for Soil Groups of the Casagrande Soils Classification as Used by Corps of Engineers, Department of the Army	132
K	1	V (11; a1cdef) km/hr., Narrow-All Terrain	135
	2	V (11; 32cdef), km/hr., Wide-Flat	136
	3	V (11; 22:def), km/hr., Wide-Hilly	136
	4	V (11; 12cdef), km/hr., Wide-Mountainous	136

APPENDIX A

SIMDATS

PRELIMINARY TRANSPORTATION SIMULATION PROGRAM

INTRODUCTION

The basic objective of the Developing Area Transportation Systems (DATS) study is to analyze the planning and use of the transportation system of a developing country in order to maintain and improve that country's social and economic development capability while ensuring that the military mobility and logistic requirements are adequately met. The transportation system model designed to represent the transportation network of a developing country has been formulated and discussed in the main body of this report. This appendix describes a preliminary digital computer simulation program capable of providing a systematic analysis of the behavior of the model, some of the mathematical techniques used, the inputs required, and the outputs generated. The program is intended to be representative rather than to be in a final form.

The program, hereafter referred to as the SIMDATS program, will be capable of analyzing several different aspects of the total problem. The program will provide a computer drawn map based on user inputs showing regional terrain features, boundaries, roads, names and geo-statistical distributions. With the specification of input data describing the physical terrain, vehicle characteristics and transportation segments, the SIMDATS program will be able to analyze vehicle performance between any two locales along the transportation system including determination of minimum time routes and vehicle mobility capabilities. The program will also be able to determine the minimum time routes between any or all of the locales listed for the region under analysis including the effects of transferring cargo between vehicles. Given a distribution of the type and quantity of resources and requirements among the locales in the region, the program will be capable of determining an allocation schedule for the distribution of the given resources among the locales with given requirements, and of reallocating the resources among the locales designated as resource centers. The logical block structure of the program is designed such that expansion of the program's capabilities can be accomplished in a straightforward and efficient manner.

The results of the SIMDATS program will provide an in-depth picture of the overall transportation capabilities of a given region with a specified mix of vehicles. The transportation system analyst will have at his disposal information describing the minimum time route structure for a given vehicle, the allocation schedule for distributing a given set of resources based on a user specified system of priorities, and a reallocation schedule for determining a redistribution of the resources available. The program will also provide vehicle mobility maps including travel time maps for given vehicles.

With this information an analysis of a developing area transportation system can be performed to determine the steps necessary to correct any weaknesses and deficiencies indicated by the output of the program.

PROGRAM DESCRIPTION

The computer simulation program described herein was designed to implement the transportation system model developed in the DATS study. In this simulation program, the total territorial area under consideration will be explicitly defined as the region, having three main functional subdivisions; locales, transportation routes, and transportation segments, regardless of any natural geographical or political divisions that may exist. In addition, a (possibly) nonfunctional subdivision termed an elemental area shall be introduced for descriptive purposes. A locale is any logical subdivision of the region that may be assigned a unique set of descriptive military and economic resources and requirements. An elemental area is any convenient, easily handled area containing two termini or nodes connected by a transportation route. The transportation route may be a road, waterway, or any combination of anything similar in nature. Its termini may logically be locales, or a locale itself may contain several transportation routes. The transportation route is described in terms of the types of vehicles that are capable of passing over it and in terms of the capabilities and limitations of the vehicles with respect to the terrain of the local elemental area, considering seasonal weather conditions.

The basic unit of the transportation model is the transportation segment, defined as any small, continuous path which may be described by a common set of physical terrain parameters. These segments are the building blocks of the transportation routes, and when correlated with the data associated with specific vehicles using the segment, yield the above-stated set of descriptors for the transportation route. The transportation segments may be combined in a variety of optional ways, allowing the resulting routes to take on an assortment of vehicle-path configurations.

In the hierarchy of the transportation model, the transportation segments are basic units, a given set making up the transportation route of a given elemental area. The transportation routes are, in turn logical elements of the total transportation network servicing the region and its various locales. It is expected that with this breakdown of locales and elemental areas (the elemental areas described in terms of their military and economic transportation requirements) an evaluation of how well each locale is serviced may be made. Indeed a comprehensive evaluation of the total regional transportation network may well be made.

The SIMDATS program itself is divided into four basic functional parts as follows:

1. Map generation
2. Elemental area analysis
3. Region analysis
4. Determination of allocation and reallocation schedules

The map generation routine provides computer drawn maps of the regions being analyzed showing any or all of the following information: terrain characteristics, transportation routes, locations of towns, cities, hamlets, etc., population distributions and geographic boundaries. These maps provide the background material which will enable the study of a transportation problem in its proper perspective.

The elemental area analysis subprogram determines the capabilities of specified vehicles over the route structure between two given locales. The analysis considers the two-way travel characteristics of specified vehicles over the primary, secondary and program determined minimum time routes. With these results vehicle mobility maps are obtained.

The region analysis subprogram extends the results of the elemental area analysis to the entire set or a subset of all the locales contained within the region being investigated. This analysis provides for the determination of the minimum time routes between all the locales of interest. Included in the analysis is the effect on travel time of transferring cargo between vehicles.

The allocation and reallocation schedule subprogram determines the optimum allocation schedule for the distribution of given resources among the locales with given requirements, and also determines the optimum resource reallocation schedule for the redistribution of the given resources among the locales designated as resource centers. A user input is used to specify the relative priorities among the locales with requirements. The subprogram also provides a chart showing the time history of arrival of the resources at the locales.

Program Physical Characteristics

The major physical characteristics of the SIMDATS computer program are described in the following paragraphs.

General Program Characteristics

The SIMDATS program will be coded in Fortran IV for use on CDC 6600 digital computers. The graphical output associated with the program will be provided by the JC4020 Electronic Plotter.

Input Organization

The SIMDATS program will use a method of data-card input which is designed to provide a high degree of flexibility, efficiency, and reliability. This method is a basic deck-reference run-case concept. This technique of inputting data allows the user to modify his data with very little additional effort while still maintaining a high level of accuracy. Briefly, the basic deck is composed of data which rarely change, the reference run

contains data which are fixed for a family of runs, and a case data which will change from run to run. The basic deck data may be modified by reference run and/or case data, and the reference run data may be modified by case data. Variable length tables providing for the input of multi-dependent data requiring interpolation will also be provided. This type of input is very useful in the handling of data such as vehicle speed characteristics for various grades for given terrain, vehicle and environmental conditions.

Program Organization

The program is divided into subprograms, which are a logical division of the problem areas to be analyzed, in terms of application to the computer. Within each of these subprograms, there exist several subroutines. Equations and/or logic, having a common purpose or function, are treated as a single subroutine. This structuring of the program into subprograms and subroutines provides many advantages, such as a high degree of flexibility, a reduction in programmer learning time, readily made modifications, and better control and option selection.

General Flow Diagram

Figure 1 presents the general flow diagram for the preliminary transportation simulation program, SIMDATS. Clearly seen are the four subprograms discussed earlier. Each of the subprograms is described by the input associated with it, the function it performs and the output generated. The input/output of each of the subprograms will be discussed first, and then Section 3 will explore in detail the methods and logic used in each of the subprograms.

Data Input Requirements and Output Capabilities

Map Subprogram

Possible inputs to the map subprogram are outlined below:

1. Latitudes and longitudes of the end points of straight line segments representing:
 - a. provincial and country boundaries
 - b. names of provinces, towns and hamlets
 - c. the various physically existing transportation routes of the region including waterways
 - d. the actual latitude and longitude grid lines for the region
2. Latitudes and longitudes of circles representing towns and hamlets and code numbers denoting the size of the circles.
3. Latitudes and longitudes of straight line segments representing:
 - a. the various physically existing terrains of the region
 - b. altitude contour lines
4. Latitudes and longitudes of straight line segments representing:

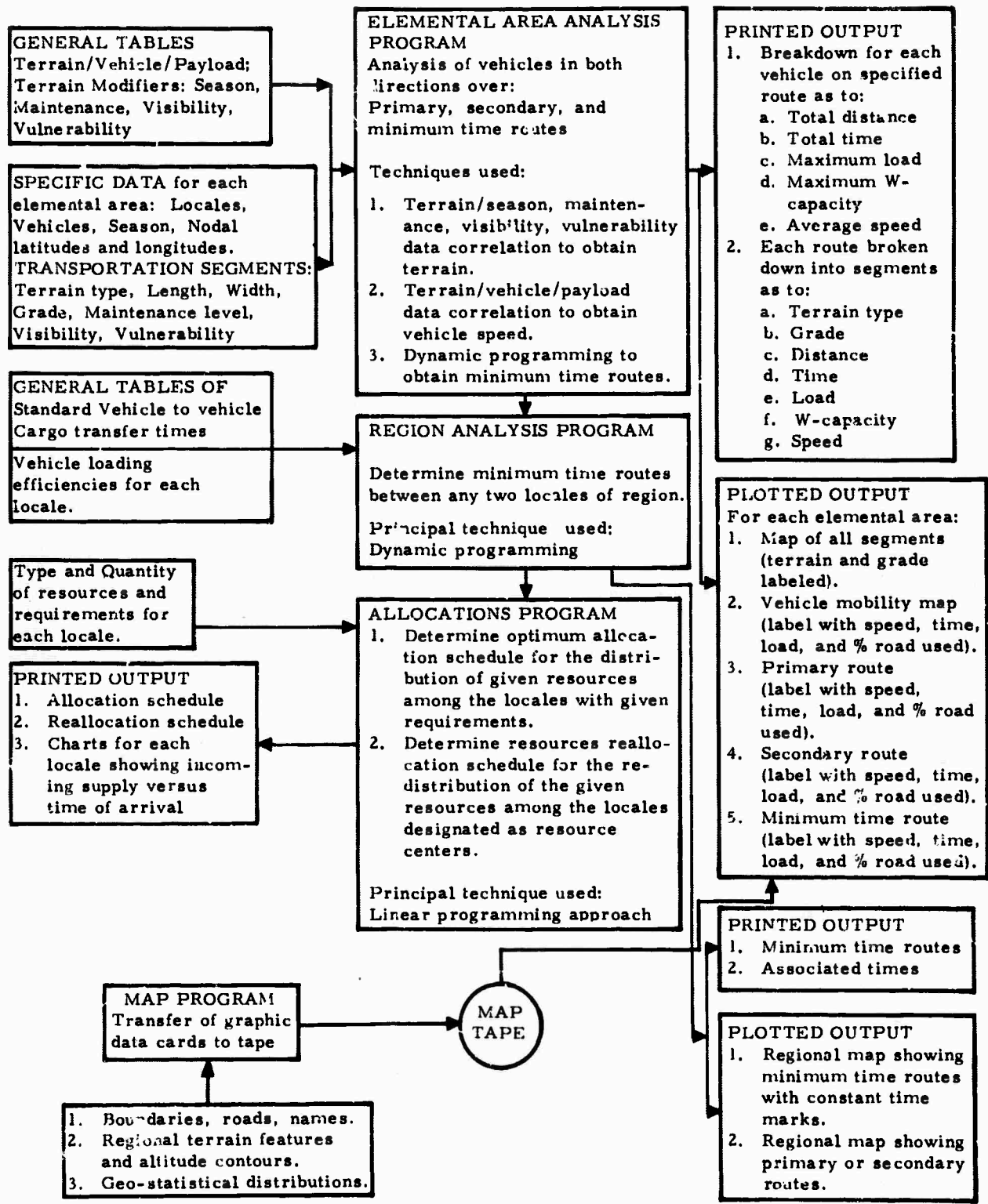

Figure 1. SIMDATS Functional Flow Diagram

- a. population density/distribution
- b. economic centers
- c. military security centers
- d. insurgency level/distribution

The above inputs will be obtained from geopolitical and geographical maps of the region. The Auto-control Model 3700 graphic digitizer will be used to reduce the map data to magnetic tape format. This automated procedure will also enable easy and rapid modifications, deletions and additions to the map data.

The basic output of the mapping capability will consist of computer drawn maps containing any combination of the above input data. These maps are expected to serve as a backdrop to the outputs from the elemental areas and region analyses.

Elemental Area Analysis Subprogram

The inputs to the elemental area analysis subprogram are given below:

1. All elemental areas will use the same general input tables of:
 - a. Vehicle speed versus grade and payload for each specific combination of vehicle and terrain type.
 - b. Terrain type modifiers versus road maintenance levels.
 - c. Terrain type modifiers versus season and weather.
 - d. Terrain type modifiers versus vulnerability of terrain.
 - e. Vehicle modifiers versus driver rating.
 - f. Vehicle type versus vehicle width and approach or departure angles.
2. Each elemental area will be described by the following inputs:
 - a. Variable length table of 1) elemental area number, 2) the two locale numbers contained in the elemental area, 3) option to analyze the given vehicles over the primary, the secondary, or the minimum time route - or any combination, 4) the season of the year, 5) codes for the vehicles to be analyzed in the elemental area (Any one "vehicle" may be given as a combination of up to three vehicles, i.e., a convoy), and 6) longitude and latitude map limits for the elemental area.
 - b. Variable length table of 1) all the node numbers in the elemental area, 2) their latitudes, and 3) their longitudes.
 - c. Variable length table of segment data consisting of the following: 1) segment number specified by two node numbers, 2) type of segment (primary, secondary, or alternate), 3) segment terrain type, 4) segment length (miles), 5) segment width (feet), 6) grade (degrees), 7) level of maintenance, 8) visibility, and 9) vulnerability.

The elemental area analysis subprogram will generate the following outputs for each vehicle specified and for both directions of travel between the two locales of the area. (A "route" is any combination of segments extending continuously from one locale to another.)

1. Printed output:

- a. Vehicle analyzed.
- b. Type of route chosen (primary, secondary, or minimum time route).
- c. Total distance over the route.
- d. Total travel time over the route.
- e. Average vehicle speed over the route.
- f. Maximum load capacity over the route (smallest of the maximum loads on each segment making up the route).
- g. Maximum percentage of road width used on the route (largest of the percentages of each segment width used by vehicle).
- h. The route used (the sequence of node numbers over the route) and the corresponding 1) terrain type, 2) grade, 3) distance, 4) travel time, 5) speed, 6) maximum load, and 7) percentage of segment width used for each segment between nodes.

2. Plotted output:

- a. Map of the elemental area showing all road segments with the primary, secondary, and alternate segments labeled and described by terrain type and grade.
- b. Vehicle mobility map of the area showing all segments usable by each vehicle, each segment being labeled with travel time and maximum load.
- c. Map of the area for each vehicle showing all segments, with either the primary, secondary, or minimum time segments darkened and labeled with travel time and maximum load.
- d. Any of a, b, or c above may have the map backdrop as described in the map subprogram.

Region Analysis Subprogram

The inputs to the region analysis subprogram are as follows:

1. List of numbers representing those locales to be included in the region analysis.
2. Matrix of known times between locales (either input or calculated in the Elemental Area Analysis).
3. Matrix of vehicles to be used between locales.

4. Matrix of known capacities between locales (either input or calculated in the Elemental Area Analysis).
5. Standard cargo transfer times for given vehicle/vehicle combinations.
6. Vehicle loading efficiencies for locales (a number to multiply Item 5 above).
7. Time values for marking time ticks around specified locales.

The outputs from the region analysis sub-program include:

1. Map with chosen (i. e., primary, minimum time, or secondary routes) transportation system.
2. Tree map (minimum time roads only).
3. Matrix of minimum times between locales.
4. Map with constant time ticks around specified locales.

Allocation Analysis Subprogram

The inputs to the allocation subprogram are:

1. Locale numbers, type and quantity of requirements and resources for each locale, and locale priorities.
2. Matrix of times between locales.

The outputs of the allocation subprogram are:

1. Allocation schedule for the distribution of given resources among the locales with given requirements.
2. Reallocation schedule for the redistribution of given resources among the locales designated as resource centers.
3. Bar chart showing supply versus time at each locale having specified requirements.

Computer Run Time and Program Size Estimates

It is estimated that to do a complete analysis of one-hundred elemental areas for a given vehicle including generation of maps, elemental and region analyses and determination of the allocation and reallocation schedules will require approximately five minutes of CDC 6600 computing time.

The code program will be capable of being loaded directly into a 32K storage memory. For the CDC 6600 computer this represents the minimum cost configuration.

DETAILED PROGRAM FLOW CHARTS

The four basic subprograms making up the preliminary transportation simulation computer program, SIMDATS, are described in this section together with two auxiliary subroutines. Each subprogram description consists of either two or three logical subsections depending on the complexity of the material. The first subsection defines the purpose, assumptions made, definitions of terms used, and any mathematical modeling used. The second subsection is a general flow chart of the subprogram and is presented whenever it is felt that the detailed flow chart cannot be easily followed. The third subsection is the detailed flow chart showing the step-by-step logic to be performed by the program.

Map Subprogram

This section outlines the procedures to be used to obtain the Basic Map data in digitized form on a magnetic tape.

Three basic steps are required in this process, namely,

1. Drawing of maps (manual).
2. Encoding (digitizing) of map data on to punch cards.
3. Card-to-tape procedure.
4. Graphing subprogram.

Step 1. Drawing of Maps

The geographic map of the entire territory is divided into rectangular regions using a square grid, defined by the requirements of the encoding procedures. Tentatively, a side of one such square is defined as ten seconds of arc.

Several types of such maps are visualized, e. g. maps with selected geographic features, maps of population distribution, maps of the distribution of economic resources, etc.

Due to standard digitizing procedures (see step 2), the digitizing areas should not exceed 44" x 60". Thus, for a given map scale, the territory may be mapped in several sections.

This step, i. e., map drawing, is necessary in order to comply with digitizing and plotting procedures and requirements. Map features which appear as continuous curved lines (railroads, boundaries, etc.) would be approximated by short

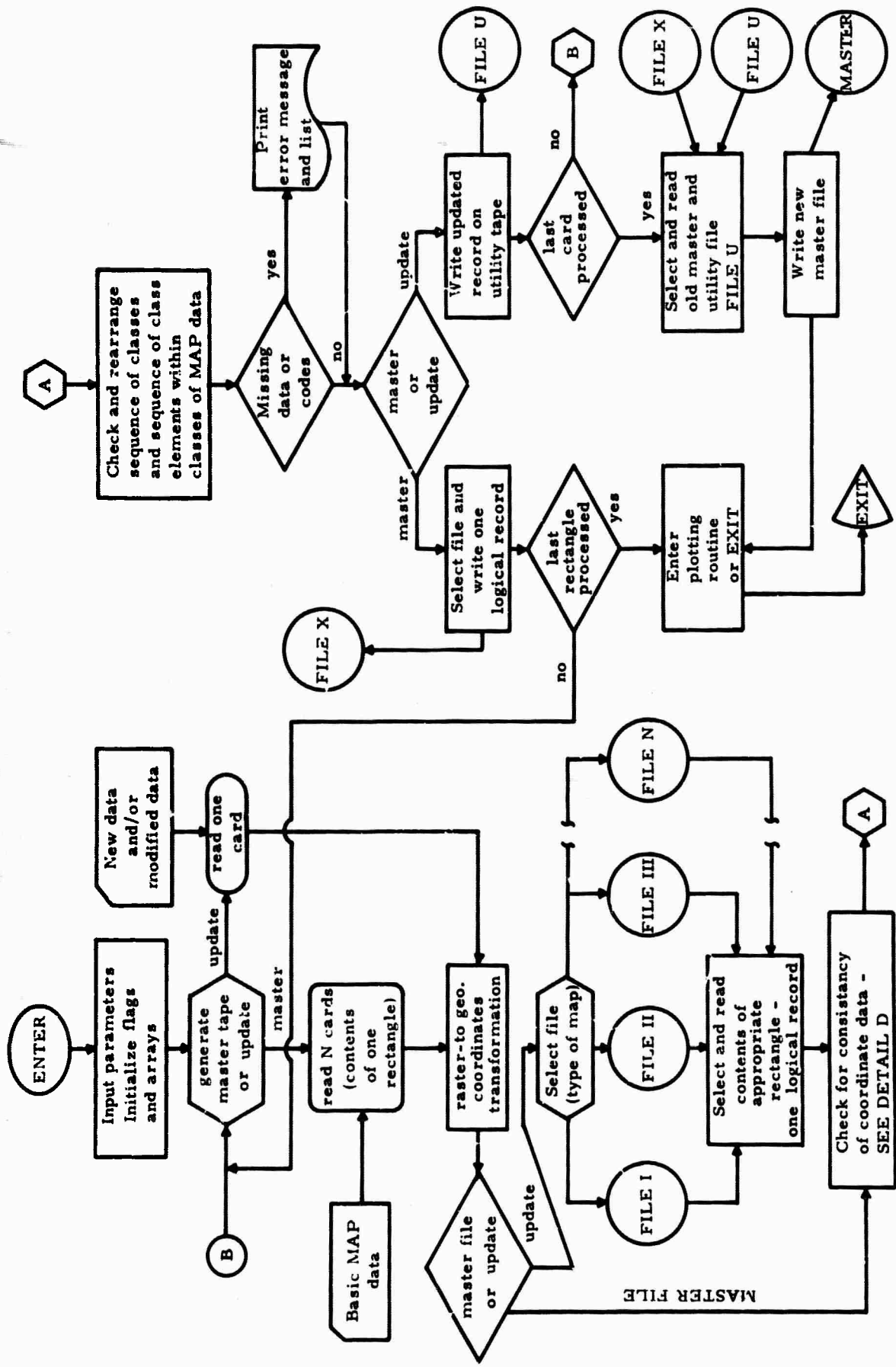

Figure 2. Detailed Flow Diagram For MAP Subprogram

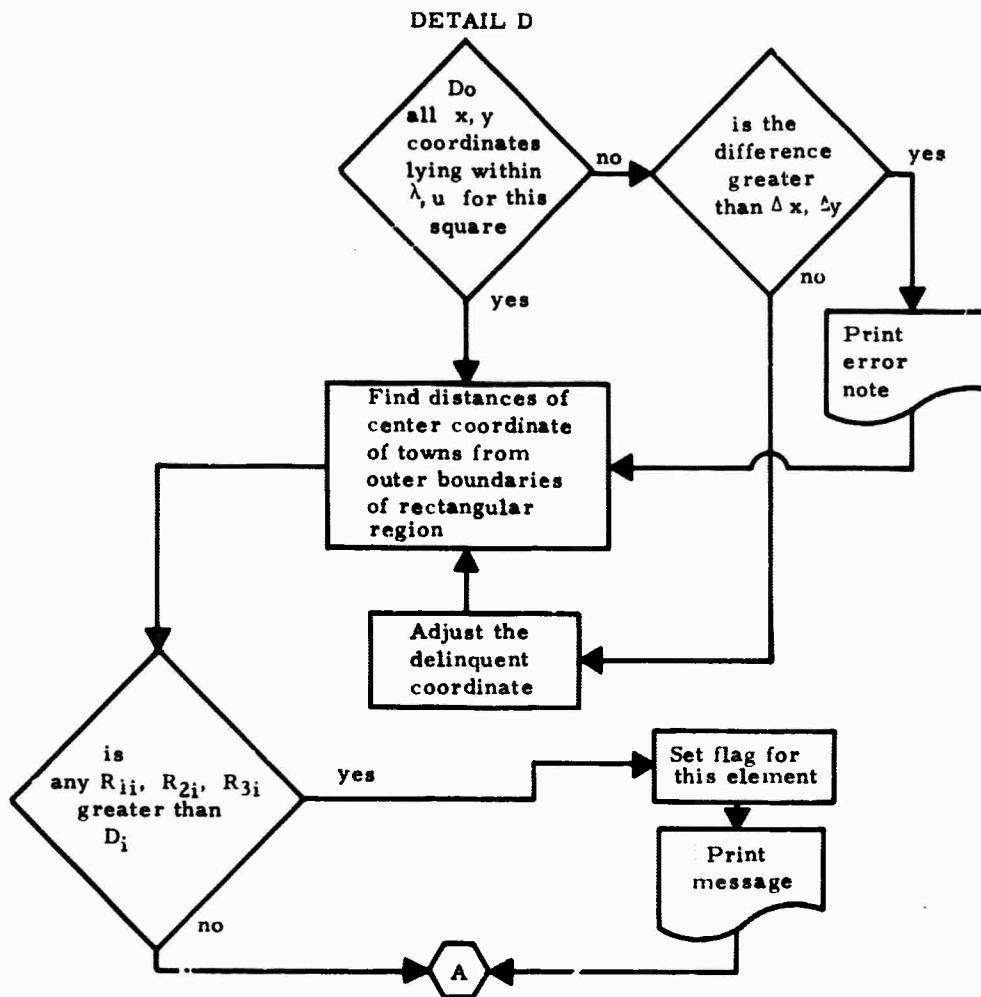

Figure 2. (Cont'd.)

straight lines segments and combinations of dotted, segmented, and solid lines.

Step 2. Digitizing the Map Data

The encoding device to be used for digitizing the map data is the Auto-trol coordinatograph Model 3929X-Y Recorder (part of the Model 3700 series). This instrument records the coordinates (raster) of any point on the map (measures to .001" on either axis). The Auto-trol scalers' output is coupled to a keypunch machine. Any computer format can be utilized by rewiring a special panel contained in the digitizer.

All the information contained within each rectangular region is digitized separately and thus forms one logical record. The records are in a strictly defined sequence for convenient retrieval.

Each class of map features is assigned a unique two-digit code; the code is included in the

basic input card format. The geographic coordinates of each map element of a given class are then encoded as a group with the assigned code number punched in a reserved field of the basic format.

The alphameric information, such as names of towns, rivers, elevation numbers, etc., cannot be keypunched concurrently with the encoding of the other data; thus a special procedure is devised. A class of map elements with alphameric information is sequenced uniquely within each rectangular region and the coordinate and ID code is encoded in that sequence. A listing of names or numbers is then produced in that same sequence for off-line keypunching.

Step 3. Card-to-Tape Procedures

A special subroutine handles the conversion of data from card to a magnetic tape. This tape then contains all the basic map data to be used for the plotting and analysis routines.

The card-to-tape subroutine converts all the raster coordinate data to geographic coordinates and arranges the data in proper logical records and files. This routine also has a master tape updating capability, that is to say, new or modified data may be input to the appropriate logical records.

The chart of card-to-tape procedure shows in some detail the logic flow of the subroutine.

Step 4. Graphing Subprogram

The graphing program would use the General Dynamics Electronics S-C 4020 peripheral system for the production of graphical output. This capability, combined with other features, such as high speed printer simulation and alphameric output production, makes the S-C 4020 system suitable for producing the several types of complete and labeled maps.

The graphic program reads the selected logical record from a Basic Map Data master input file and also writes the S-C 4020 control instructions on an output tape. The S-C 4020 system then reads this output tape and generates the graphical and alphameric output. As the tape is read, the desired map features (lines, points, labels and characters) are displayed on a special cathode ray tube. Film or sensitized paper is exposed to this display and the resulting maps, graphs and/or text are developed. Records and pictures can be obtained on 35 mm film.

The following additional feature may be considered at some future stage of the project development: for some data, which it is impossible or difficult to digitize, special slides are obtained from drawings. By superimposition of these slides with the computer generated data which itself is displayed on the cathode ray tube of S-C 4020, a combined picture may be obtained.

Elemental Area Analysis Subprogram

The function of this subprogram is to analyze the transportation capabilities of each elemental area of the region in terms of the physical characteristics of the transportation segments within the area, and in terms of the vehicles passing over the segments.

The program has the ability to analyze the primary, the secondary and the minimum time routes between locales, in both directions, for any vehicle or convoy of up to three vehicles. The primary and secondary routes are a combination of user specified segments, but the minimum time route is determined by analysis subroutine DYNAMIC. The actual mathematical analysis of each segment is performed by subroutine SEGMENT.

Definitions

- Elemental Area** - Any geographic area of the region containing two locales and a network of primary, secondary, and alternate routes between.
- Route** - Any continuous combination of primary, secondary, and alternate segments connecting the two locales of an elemental area.
- Locale** - One of the two termini of an elemental area, described as having a unique set of military and economic requirements and resources.
- Segment** - Any continuous portion of a route which can be described by a constant set of physical terrain parameters along the segment.

Region Analysis Subprogram

Given the travel times for given vehicles over any of the primary, the secondary, or the minimum time route between adjacent locales, the function of this subprogram is to dynamically determine the minimum travel routes between each pair of locales of the region.

Definitions

$[t_{IJ}]$ The (square) matrix of travel times between all locales, the diagonal of which is zero, and most elements of which are to be determined by the regional analysis.

$$i = 1, 2, \dots, I, j = 1, 2, \dots, J, I = J$$

OLOCAL The m^{th} offspring locale of the i^{th} locale,
(i, m) $m = 1, 2, \dots, 8$

$t_{L, O}$ The travel time along the route from locale (i) to offspring locale OLOCAL (i, 1) as determined by the elemental area program.

LOCALE The i^{th} locale of the set of I locales.
(i)

$[V_{IJ}]$ The matrix of best vehicles between all locales, the diagonal of which is zero, and most elements of which are missing since best vehicles are determined only between adjacent locales by the elemental area program.

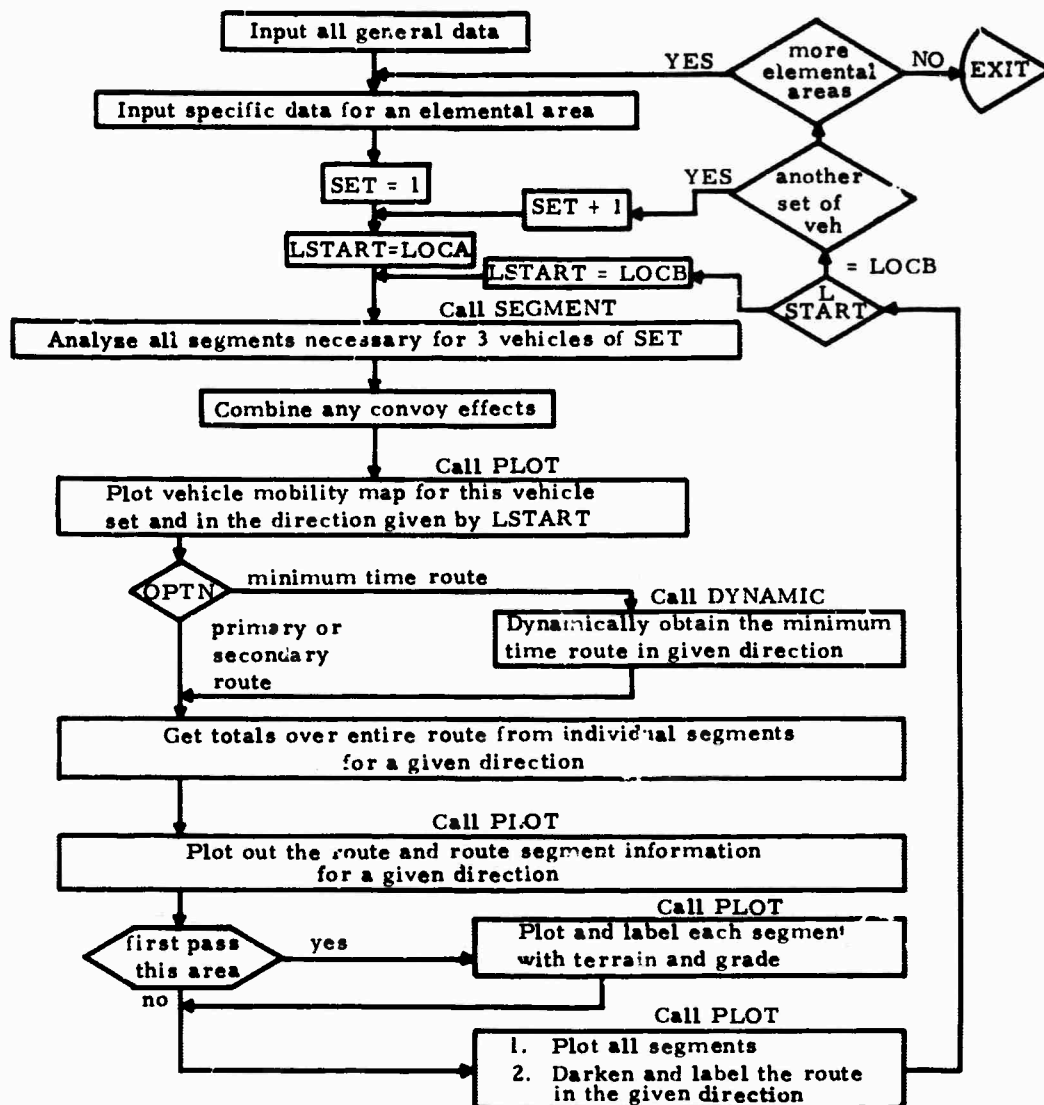

Figure 3. General Flow Diagram for Elemental Area Analysis Subprogram.

Assumptions

1. There is a possibility of asymmetric travel times between locales ($t_{ij} \neq t_{ji}$).
2. Each locale is allowed a maximum of 8 direct connections to other locales, although this is not an essential limitation. (It is introduced to simplify subroutine DYNAMIC.)
3. Locale numbers range over a single index from 1 to I.

Allocation Schedule Subprogram

Given a matrix of locales with given resources, needs, priorities, and transfer times between locales, this subprogram generates a schedule to either allocate the resources among

the locales with needs or to reallocate the resources among the centers of resource such that the needs of the locales are satisfied.

Definitions

- TYPE The type of resource and needs for which the analysis is to be performed.
- $[L_i]$ The list of all locales L_i with resources and needs $i = 1, 2, \dots, I$.
- $[T_{ij}]$ The matrix of minimum times such that T_{ij} is the minimum time from locale L_i to locale L_j .
- $i = 1, 2, \dots, I, j = 1, 2, \dots, J, I = J$.
- $[tmax_i]$ The list of maximum times such that $tmax_i$ is the maximum allowed time to supply locale L_i with all its needs N_i .

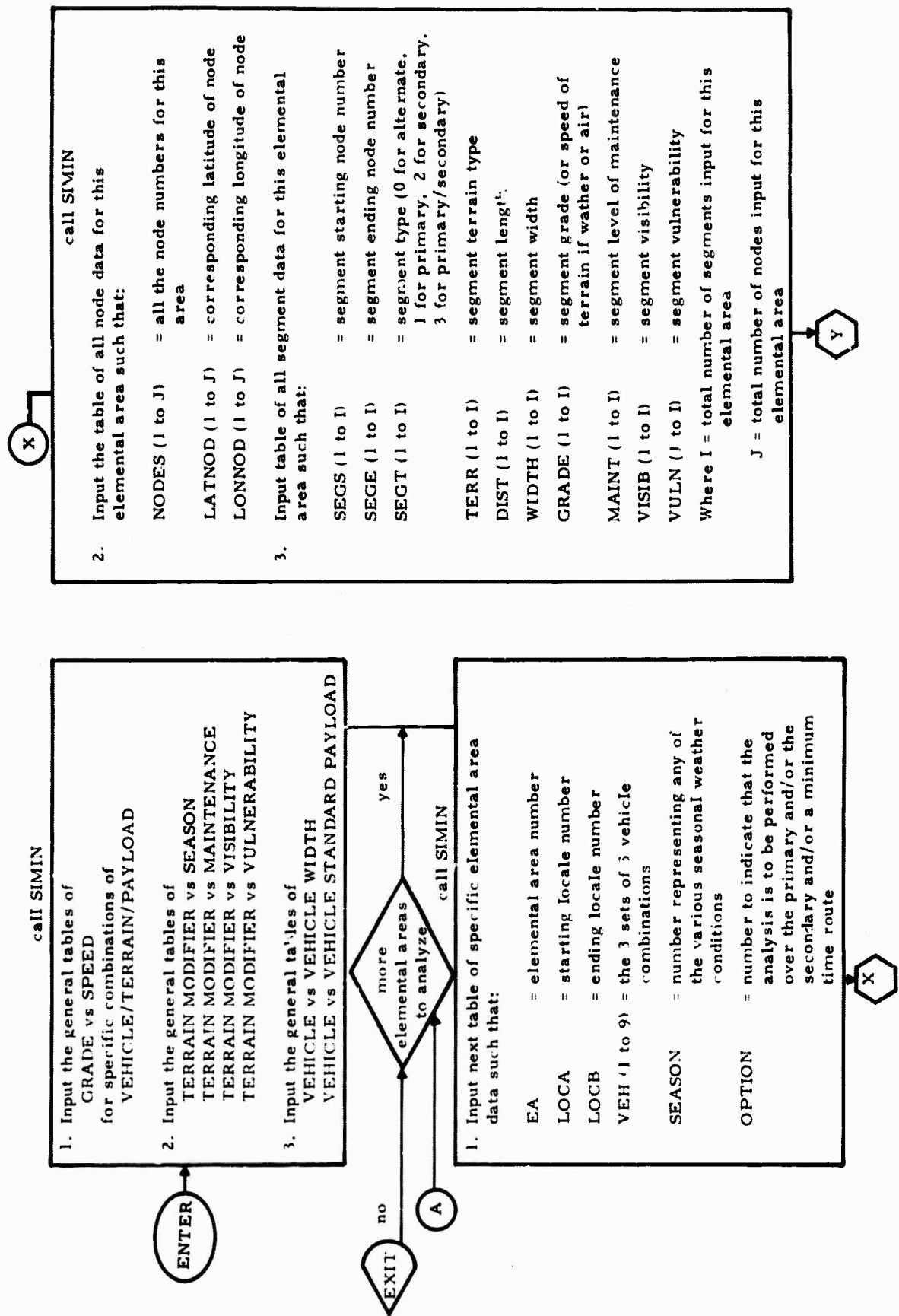
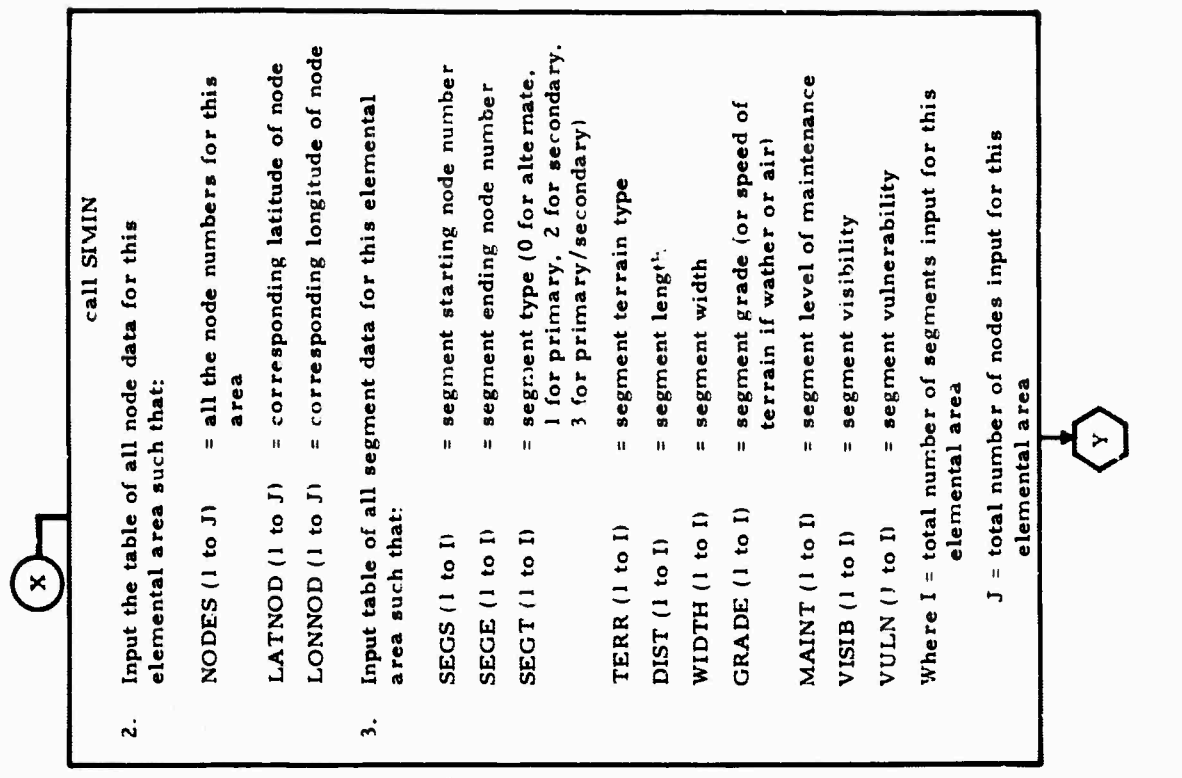

Figure 4. Detailed Flow Diagram for Elemental Area Analysis Subprogram



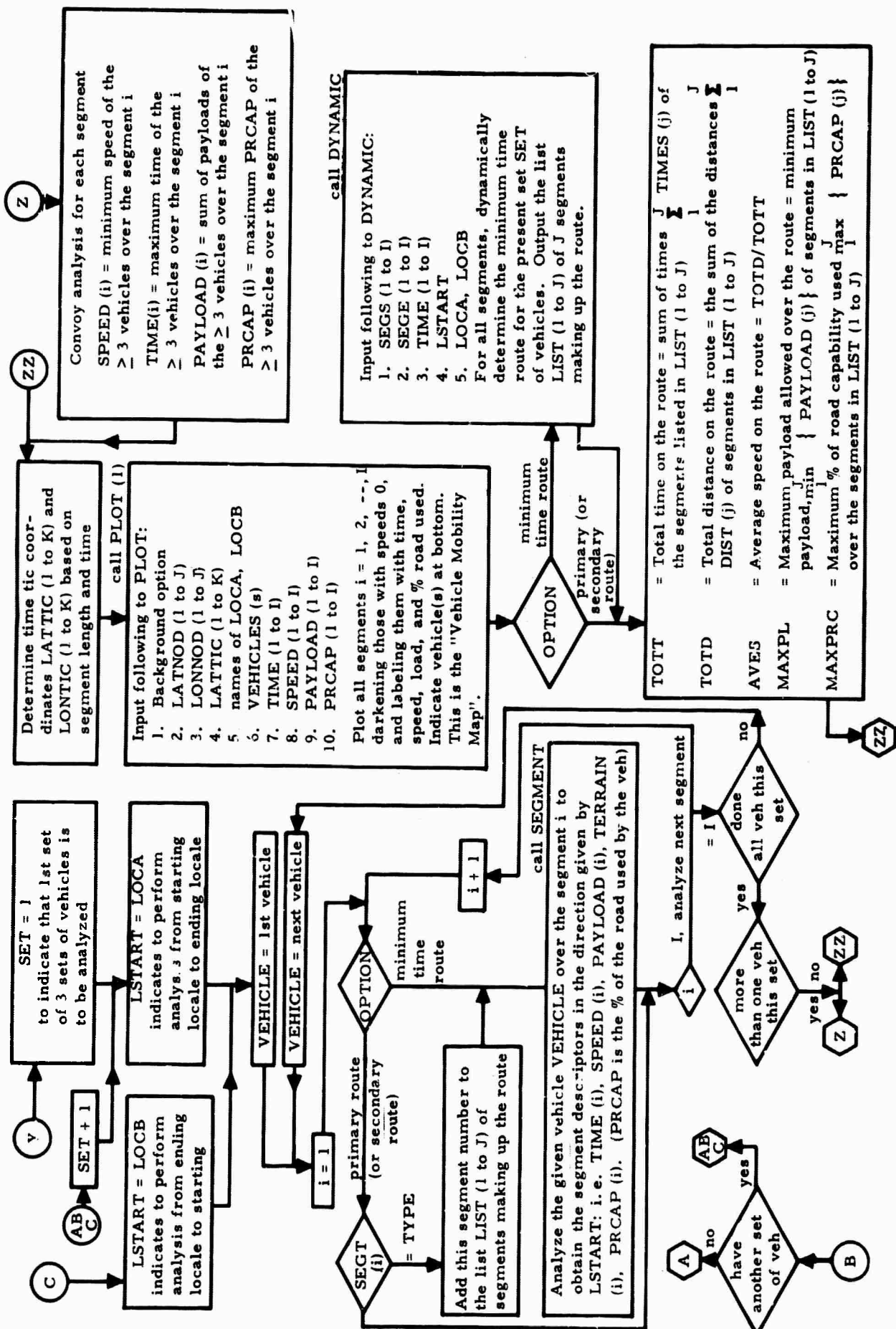

Figure 4. (Cont'd.)

PRINT OUT in the following format:

VEHICLE(s) TOTT TOTD AVES MAXPL MAXPRC Route

(Where the route has the following format)

TERR(1)	DIST(1)	WIDTH(1)	GRADE(1)	TIME(1)	SPEED(1)	PAYLOAD(1)	PRCAP(1)
(2)	(2)	(2)	(2)	(2)	(2)	(2)	(2)
.
(J)	(J)	(J)	(J)	(J)	(J)	(J)	(J)

Notes: (1) VEHICLE(s) are the ≤ 3 vehicles of the present set of vehicles SET

(2) By the series 1, 2, ---, J is meant only those of the series of segment information 1, 2, ---, I that are included in the presently analyzed route

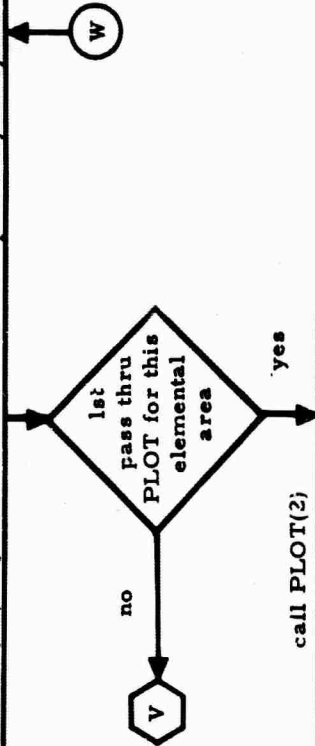

Input the following to PLOT:

1. Background option
2. TERR(1 to I)
3. GRADE(1 to I)
4. LATNOD (1 to I)
5. LONNOD(1 to I)
6. LOCA, LOCB
7. names of LOCA and LOCB

Plot all segments i = 1, 2, --, I and label each with terrain type and grade. Label the starting and ending locales by name and number.



call PLOT(3)

Input the following to PLOT:

1. Background option (a number to indicate what combination of the three types of map background is wanted, if any at all)
2. LATNOD (1 to I)
3. LONNOD (1 to I)
4. LOCA, LOCB
5. names of LOCA, LOCB
6. VEHICLE(s)
7. TOTT
8. TOTD
9. AVES
10. MAXPL
11. MAXPRC
12. TIME (1 to J)
13. SPEED (1 to J)
14. PAYLOAD (1 to J)
15. PRCAP (1 to J)
16. OPTION

Plot all segments of the area i = 1, 2, --, I darkening those belonging to the route just analyzed j = 1, 2, --, J (i.e. the primary, secondary, or the minimum time route)

Label those darkened with time, payload, and % road used.

Indicate VEHICLE(s), TOTT, TOTD, AVES, MAXPL, MAXPRC, and type of route at bottom of plot



Figure 4. (Cont'd.)

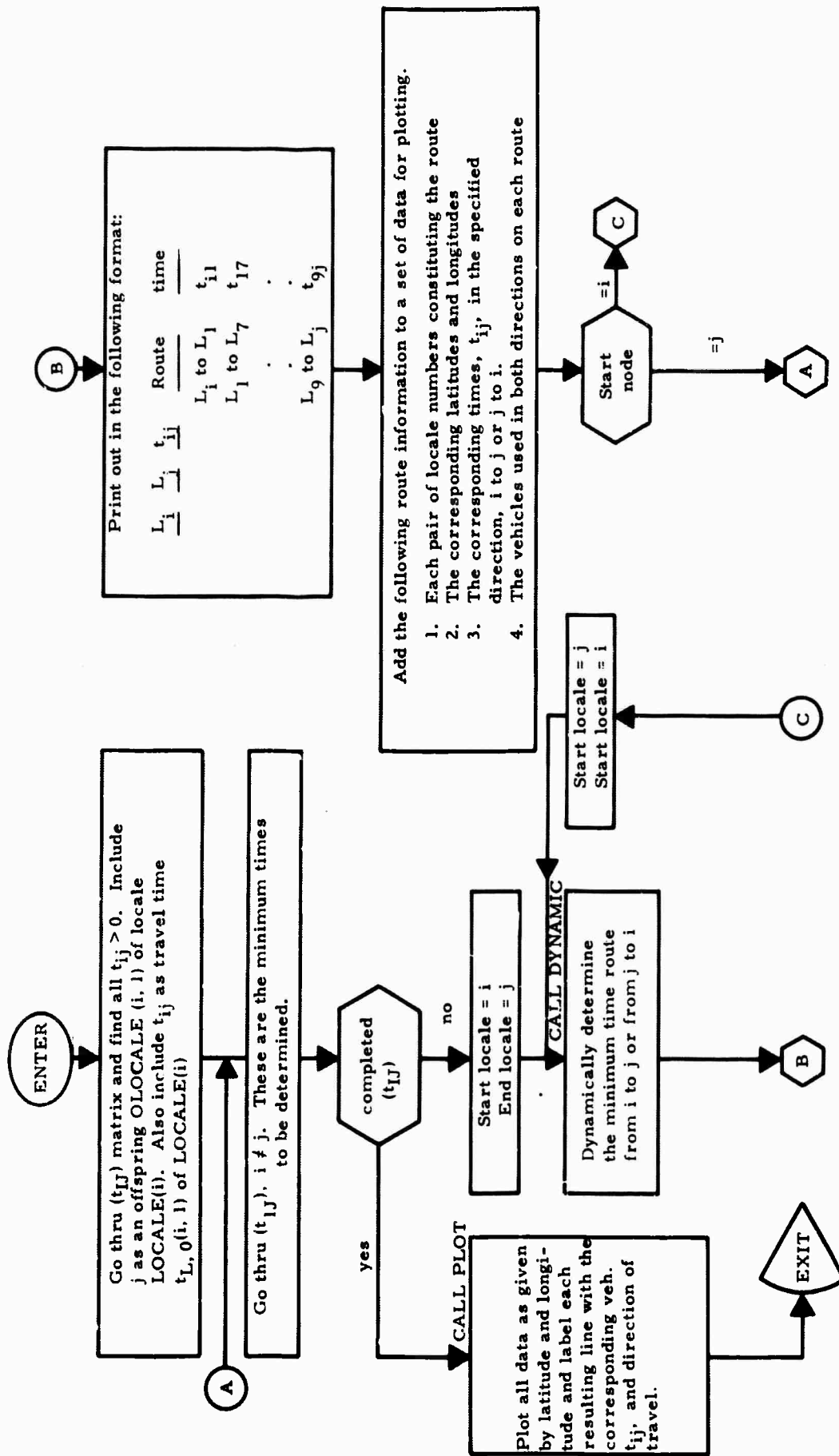

Figure 5. Detailed Flow Diagram for Region Analysis Subprogram

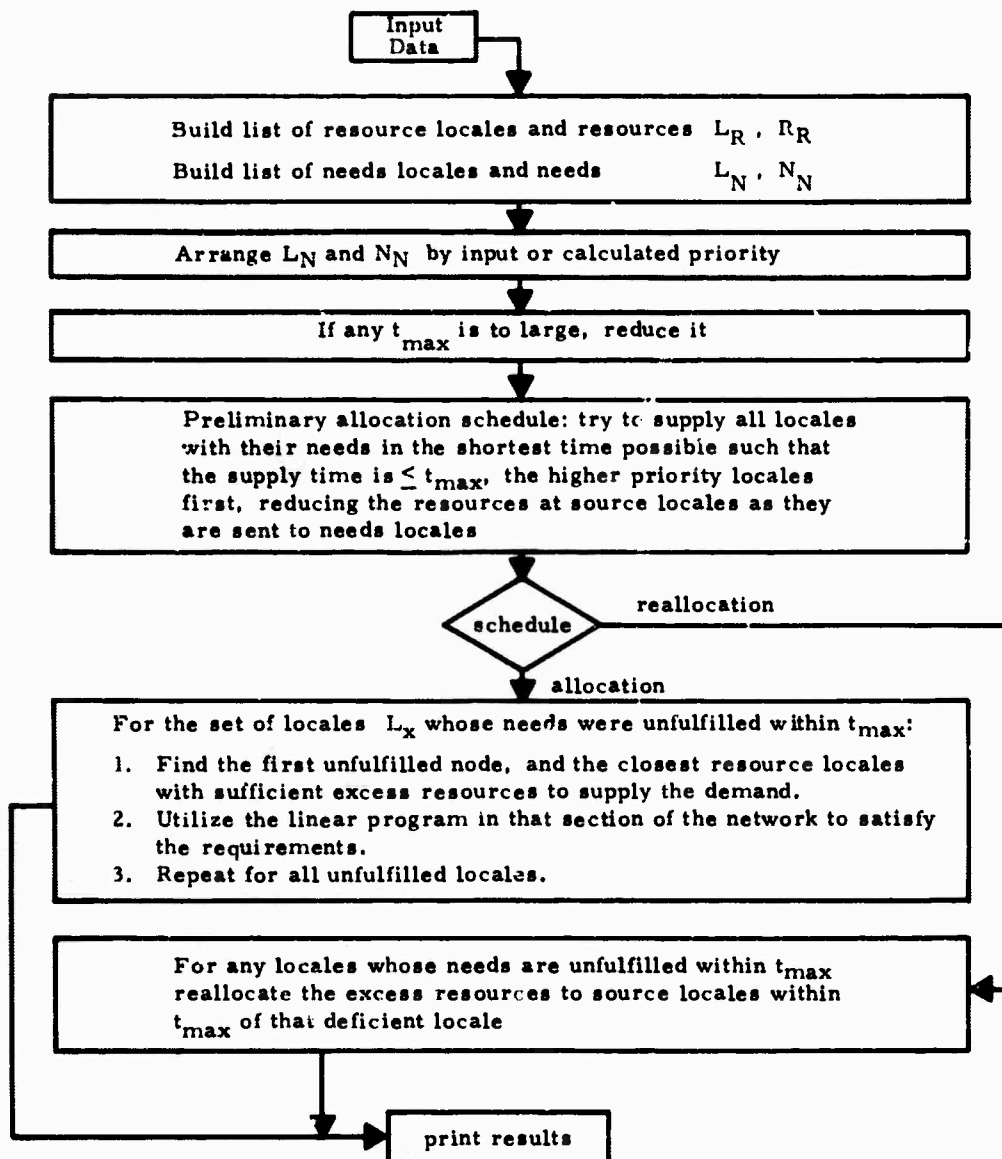

Figure 6. General Flow Diagram for Allocation Schedule Subprogram

$\{R_i\}$	The list of resources such that R_i is the quantity of resources of type TYPE at locale L_i .	$\{N_n\}$	The list of needs of type TYPE such that N_n is the quantity of need at locale L_n .
$\{TR_i\}$	The list of resource types such that TR_i is the type of resource at locale L_i .	$\{t_n\}$	The list of numbers such that t_n is an index of how close to t_{max_n} is the actual time to fulfill the needs of locale L_n .
$\{N_i\}$	The list of needs such that N_i is the quantity of needs of type TYPE at locale L_i .	$\{L_r\}$	The list of locales with resources of type TYPE such that L_r is the locale with quantity of resource R_r , $r = 1, 2, \dots, R$.
$\{TN_i\}$	The list of need types such that TN_i is the type of need at locale L_i .	$\{R_r\}$	The list of resources of type TYPE such that R_r is the quantity of resource at locale L_r .
$\{P_i\}$	The list of priorities such that p_i is the priority of locale L_i .	TBEST	The shortest possible time to satisfy the needs of a given locale.
$\{L_n\}$	The list of locales with need of type TYPE, listed in order of priority, such that L_n is the locale of priority n with the quantity of needs N_n . $n = 1, 2, \dots, N$.	$\{LL\}$	The logic of the program necessitates a data array, LL, of dimensions (R, N) which keeps track of the quantities of

resources, $LL(r, n)$, sent from locales L_r to locales L_n , $r = 1, 2 \dots N$;
 $n = 1, 2, \dots J$.

Program Logic

In the allocation schedule logic used, a system of the type described and depicted below might be employed. $R_1, R_2, \dots R_R$ represent the quantities of resource available, and $N_1, N_2, \dots N_N$ represent the quantities of needs listed in priority order, at given locales. If a transfer time is not shown between two locales, it indicates that the transfer time is greater than the maximum allowable transfer time required to the locale to be supplied.

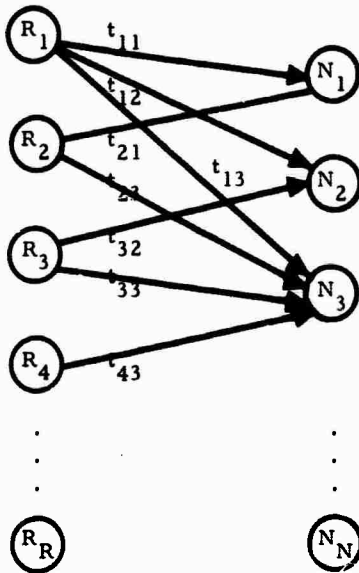

The allocation takes place according to the following scheme which assumes that a definite priority is established for supplying the need points.

1. The needs N_1 are first filled in as optimum a time as possible: e. g., say $t_{11} < t_{12}$ and $R_1 < N_1$. Then all of R_1 and part of R_2 goes to N_1 . R_1 is reduced to zero and R_2 is reduced to $R_2 + (R_1 - N_1) U(N_1 - R_1)$, where $U(y)$ is the unit step function at $y = 0$.
2. The needs $N_2, N_2, \dots N_N$ are then filled in that order and according to the logic above.
3. When completed, some needs may not have been filled due to over-optimizing the schedule of higher priority locales. If this is the case, then a straightforward application of standard linear programming techniques can be made to that portion of the network in which excess resources exist at some supply nodes and resource deficits exist at other nodes. This is permissible, since all transit times utilized in the

network are less than the specified maximum allowable.

In the reallocation scheduling the logic in 1 and 2 still applies. When completed some needs may not have been filled at certain locales, L_x . Since the total quantity of resources is \geq total quantity of needs, some locales, L_y , have excess resources. If this is so, then a simple minimum reallocation of these excess resources is made to a source locale, L_z , within reach of L_x , preferentially from the L_y closest to L_z .

Auxillary Subroutines

It has been found convenient to generate separately the two subroutines SEGMENT and DYNAMIC. SEGMENT is used only by the Elemental Area Analysis subprogram and the Region Analysis Subprogram.

SEGMENT Discussion

The function of SEGMENT is to determine a set of segment descriptors (terrain, speed, time, % road used and payload) given the type of vehicle passing over the segment and a certain set of vehicle and terrain modifiers.

Definitions

- TERRAIN** A term descriptive of the segment medium on which the vehicle travels, be it a road, trackless waste, etc.
- PAYLOAD** The weight carried by the vehicle over the segment.
- GRADE** The grade of the segment or if the terrain is water or air, the speed of the segment. (+ in direction of travel).
- PRCAP** The percentage of the available segment width that is used by the vehicle.

Mathematical Modeling. The most difficult and important segment descriptor is the speed of the vehicle over the segment. The model used to determine the speed is a data model and is strictly dependent on how well the user can describe the effects of environment on the terrain and how much he knows of the various vehicle/payload combinations over each type of terrain. The data is input in tables at this point.

If one knew the effect of season alone on a given terrain he could reclassify the terrain in that season and represent the difference by a number. This assumption is made in this program not only for the season, but also for the level of maintenance, the visibility on the terrain, and the vulnerability of the terrain. It is assumed the starting terrain number is chosen to describe the terrain in the environment such that any seasonal, maintenance, visibility, or vulnerability effects are

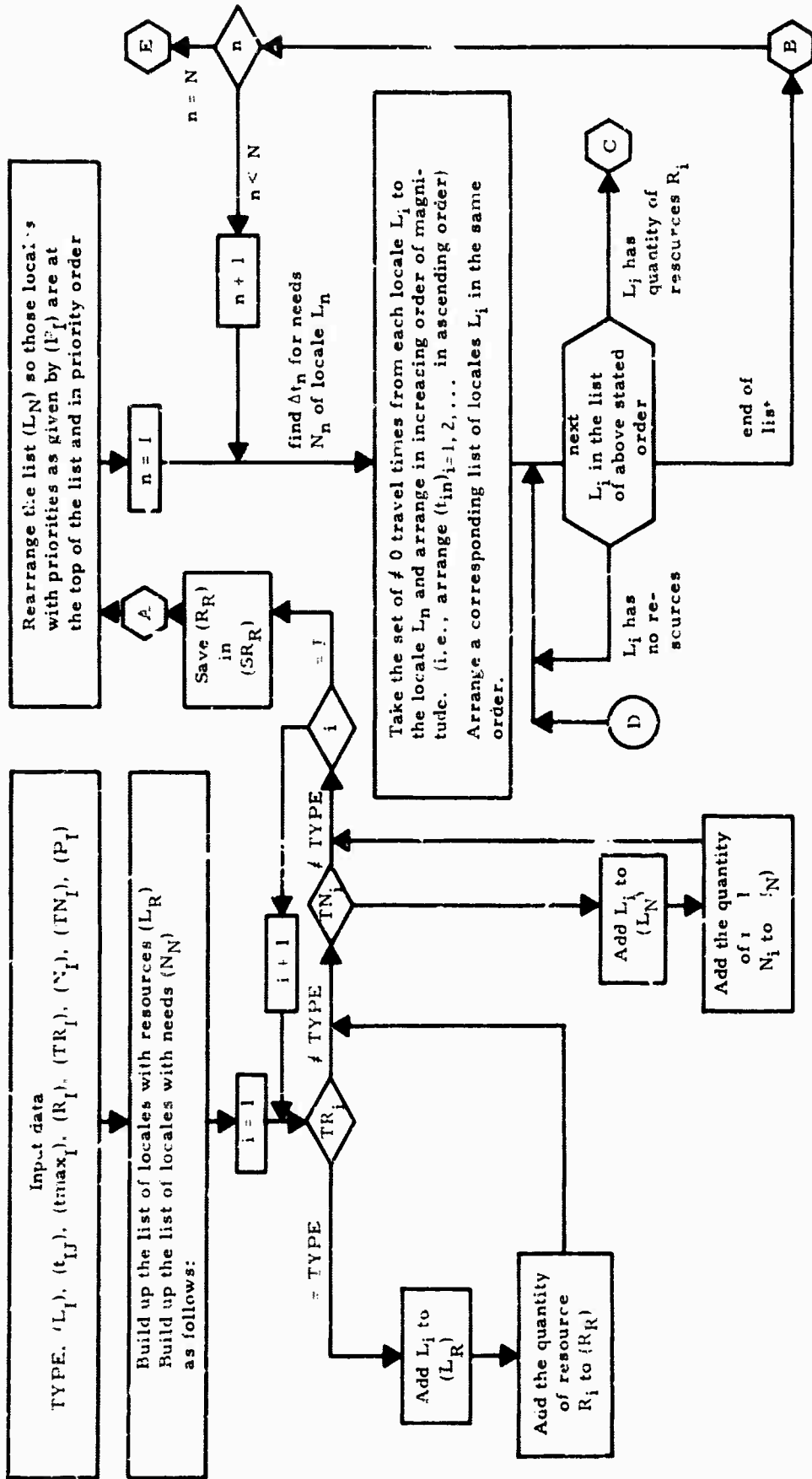

Figure 7. Detailed Flow Diagram For Allocation Schedule Subprogram

PRELIMINARY ALLOCATION

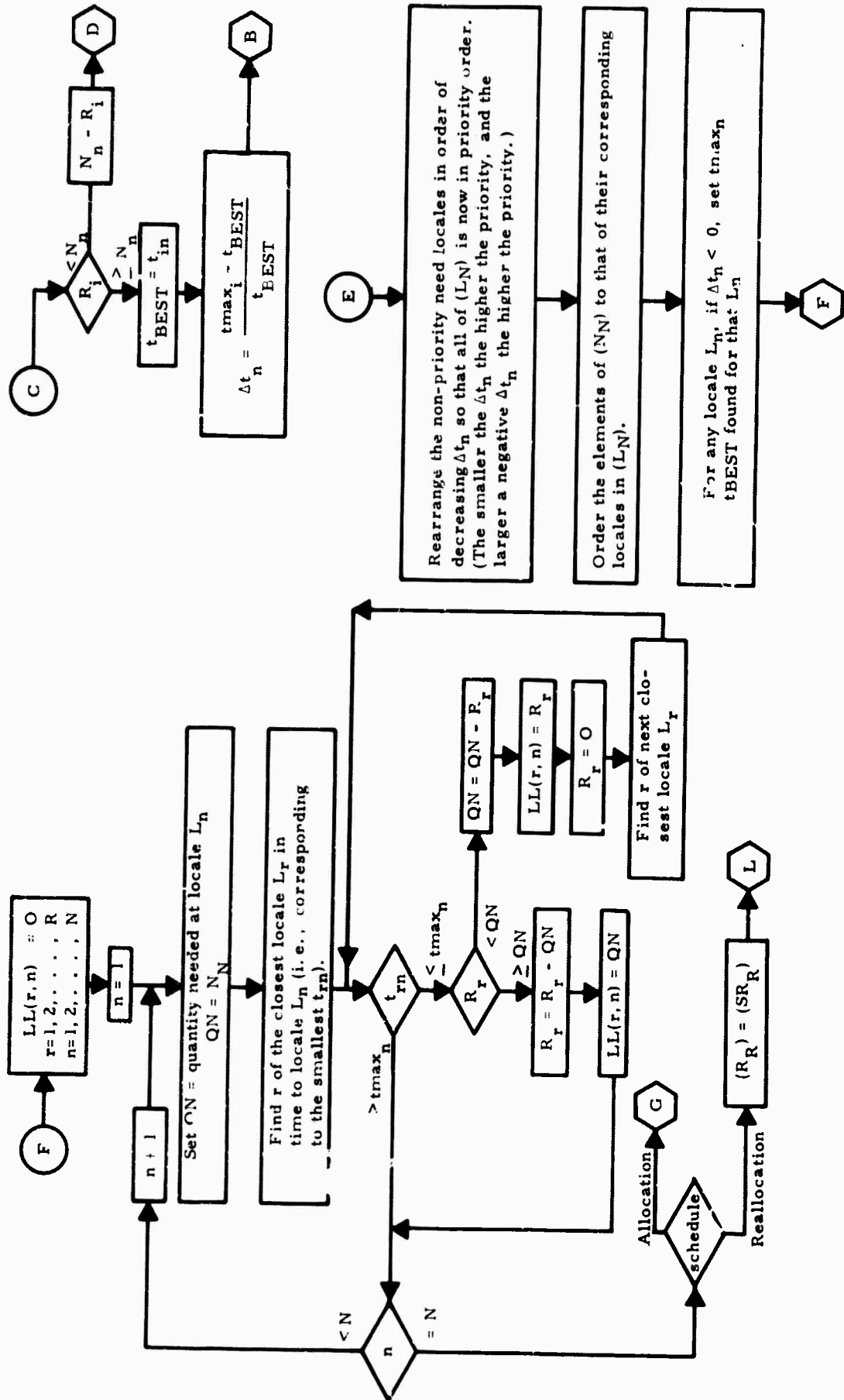

Figure 7. (Cont'd.)

ALLOCATION

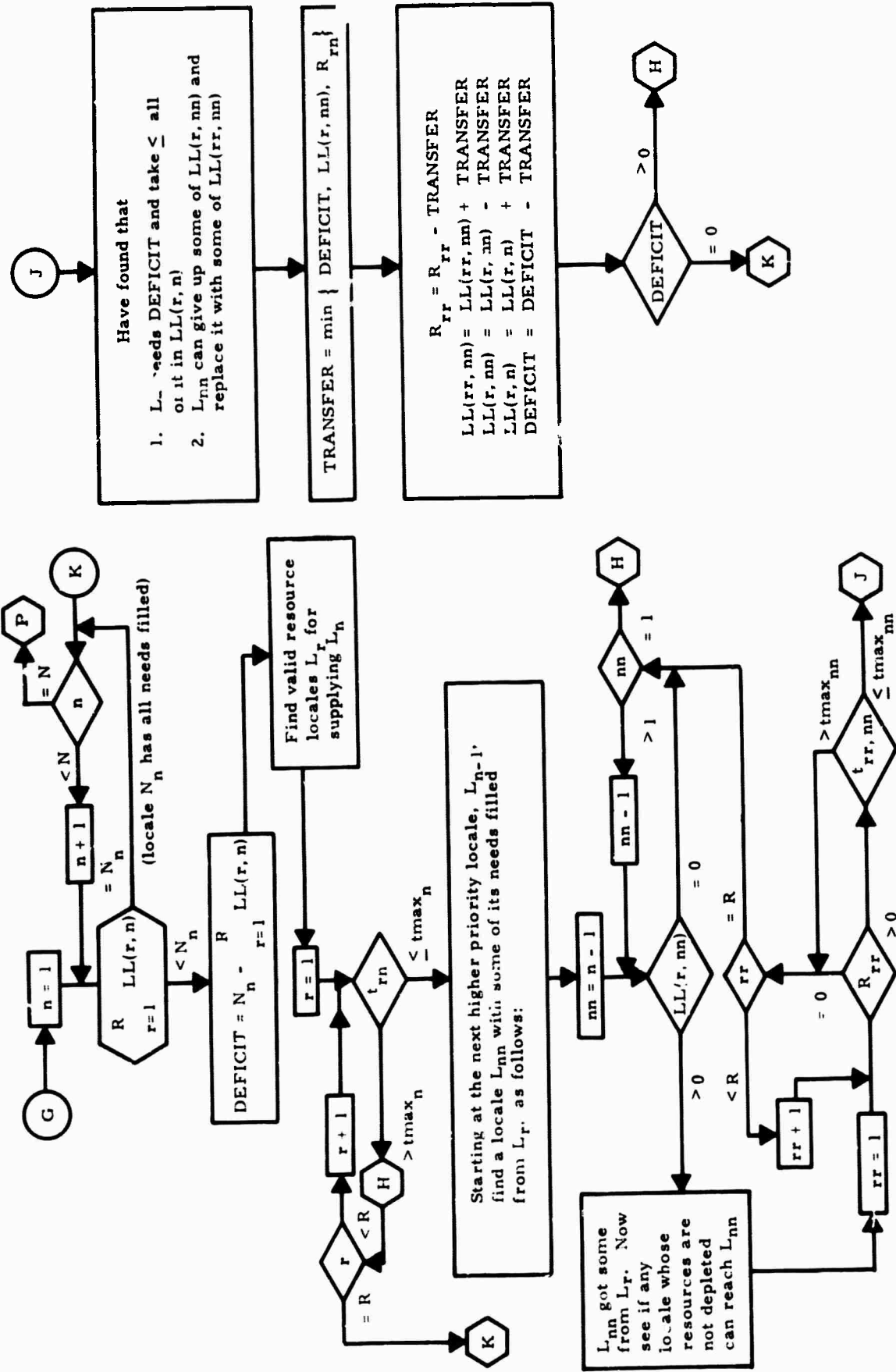

Figure 7. (Cont'd.)

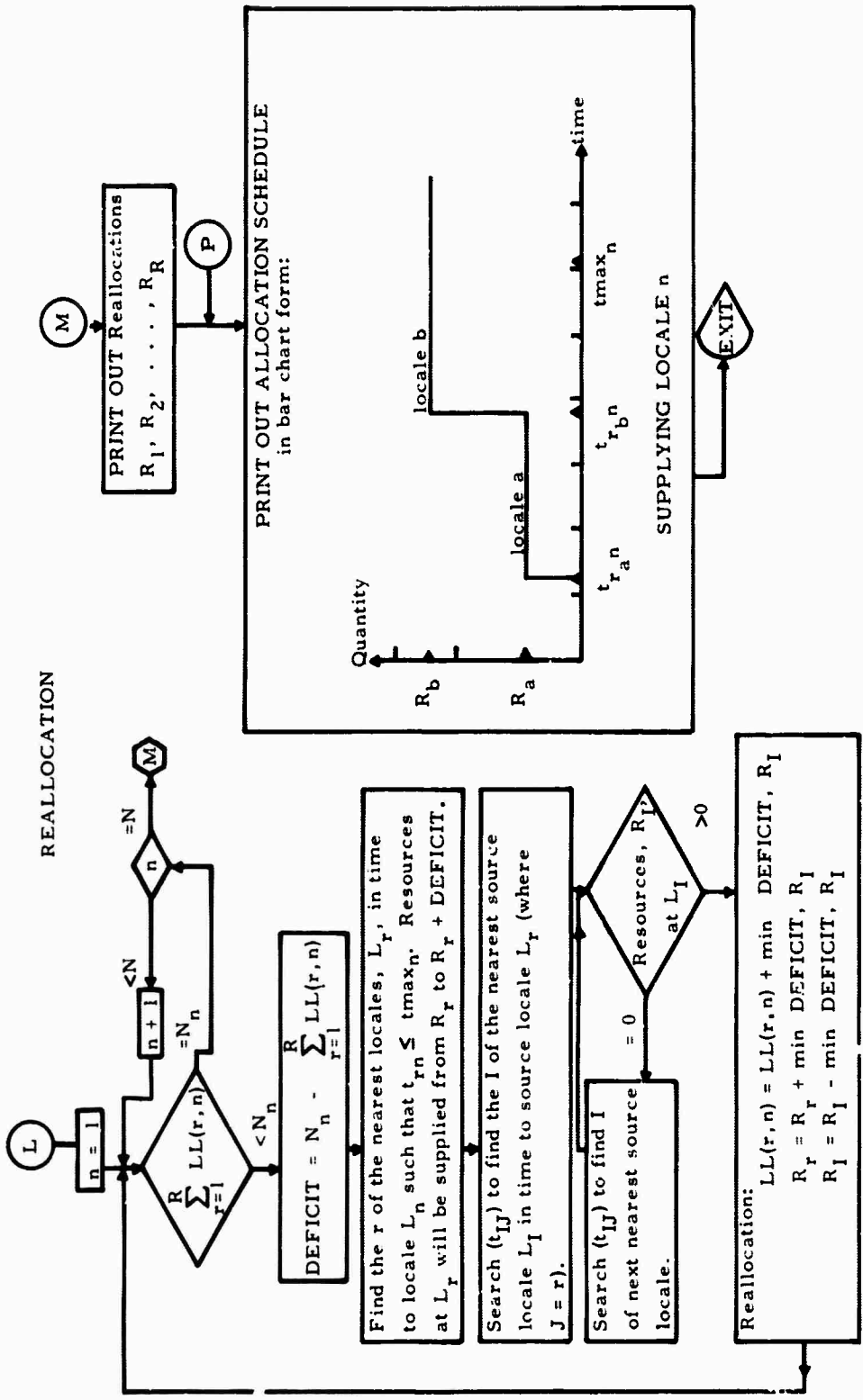

Figure 7. (Cont'd.)

negative. Thus, if the terrain were a dirt road and the season were dry, the maintenance excellent, the visibility unlimited, and the road invulnerable, the resulting terrain type should not be different from the starting terrain number. Secondly, there is tabular input data which correlates the vehicle speed and particular combinations of terrain/vehicle/payload for varying terrain grade.

Program Logic. The logic of the program operates as follows: a given terrain type is modified according to season, maintenance, visibility, and vulnerability. The standard payload for the vehicle is assumed and the non-known combination of terrain, vehicle, and payload identifies the grade/speed table to use. If the resulting speed is zero an attempt is made to find a table with the same vehicle and terrain, but with a payload that allows the vehicle to move. In this way the vehicle speed is determined. The other segment descriptors are then easily calculated since the segment length, width, etc. are known.

DYNAMIC Discussion

This subroutine dynamically determines the minimum time path through a network of interconnected nodes with known time connections, and known cargo loading times at the nodes.

Assumptions. The several assumptions which are made in the following approach are:

1. The possibility of asymmetric travel times between nodes (i. e., $t_{xy} \neq t_{yx}$) may be assumed.
2. Each vehicle arriving or leaving a node (locale) is assumed to carry the standard rated payload so that cargo transfer times at the nodes are a simple function of standard transfer times and the loading efficiencies at the nodes.
3. There will be no more than 8 segments touching any node for simplicity (which is not an essential limitation).

Definitions. The parameters used in the flow diagrams are:

NODE(k)	The node number of the k^{th} node, $k = 1, 2, \dots, K$ (may in reality be a node number or a locale number).
WAVEN(k)	The wave number of node k.
MTV(k)	The minimum time value calculated to arrive at node k measured from the starting node.
PNODE(k)	The parent node of the k^{th} node. The parent node lies along the minimum time route to node k.
ONODE (k, i)	The i^{th} offspring node of the k^{th} node, $i \leq 1, 2, \dots, 8$.
$t_{N, O} (k, i)$	The travel time along the segment from NODE (k) to offspring node ONODE (k, i).
CLE (k)	The cargo loading efficiency of the k^{th} node (filled in from load sheet data for region analysis-assumed zero for elemental area analysis).
STT (m, n)	The standard cargo-transfer time between vehicles m and n.
V (k, i)	The vehicle used along the segment from NODE (k) to offspring node ONODE (k, i).
MV	The number of the vehicle that arrived at NODE (k) over the minimum time route for that node.

Mathematical Modeling. The technique used to determine the minimum time path is that of dynamic programming which essentially eliminates the necessity of trying all possible paths, and from them choosing the best. Instead the best paths are determined to each node at the front of a "wave" spreading from the starting node. When the end node is reached, it is then necessary only to make a simple trace back to the start node.

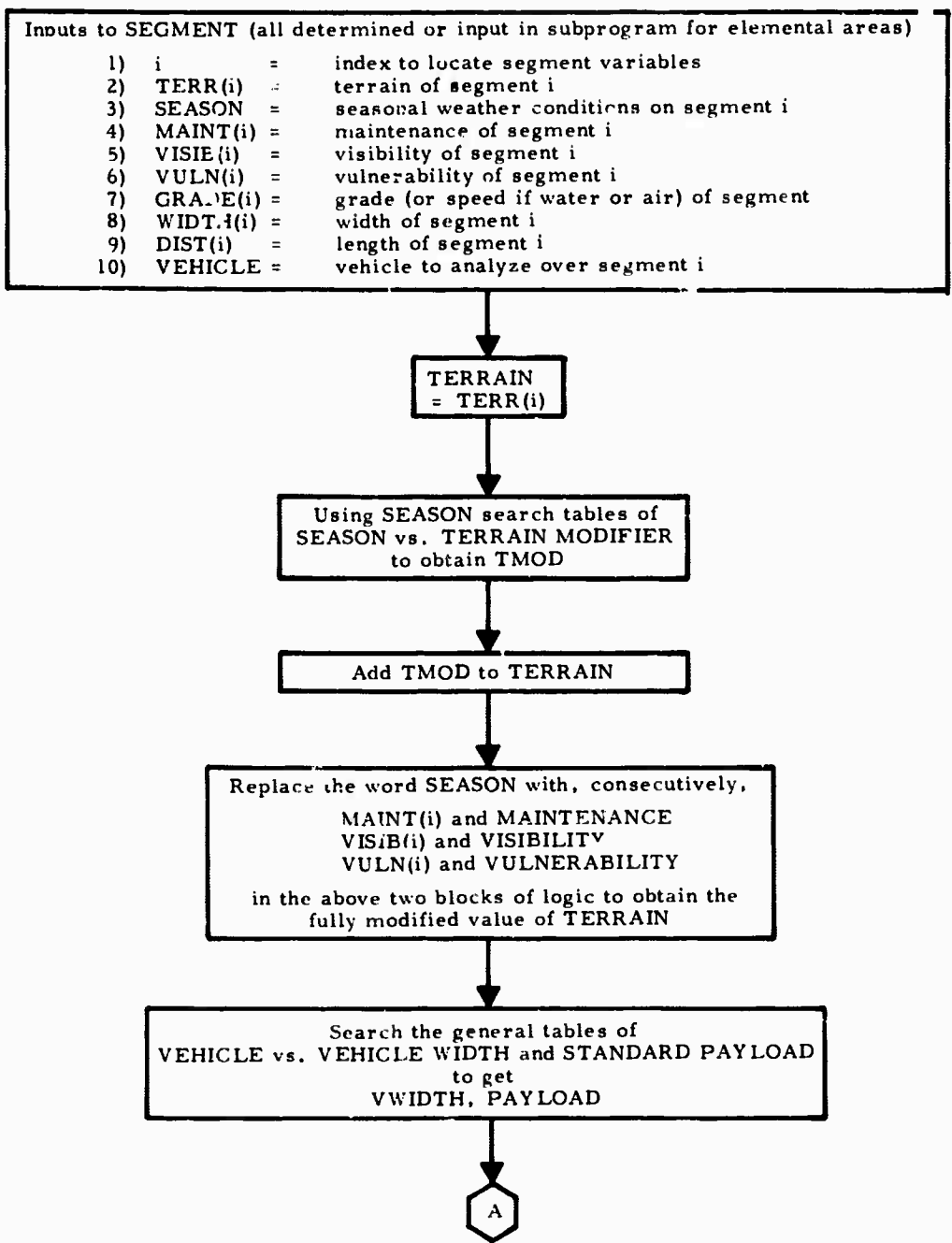

Figure 8. Detailed Flow Chart for Segment Subroutine

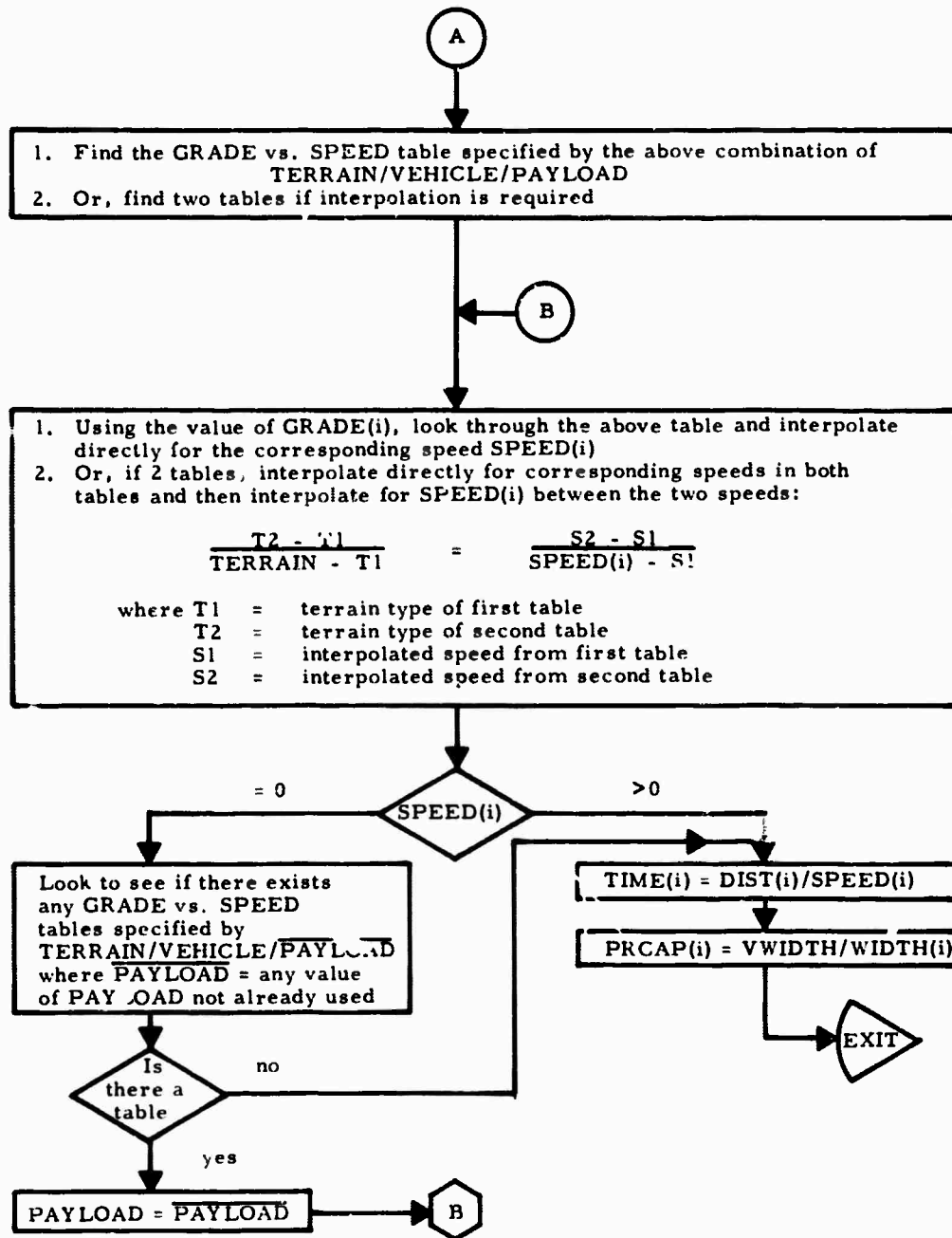

Figure 8. (Cont'd.)

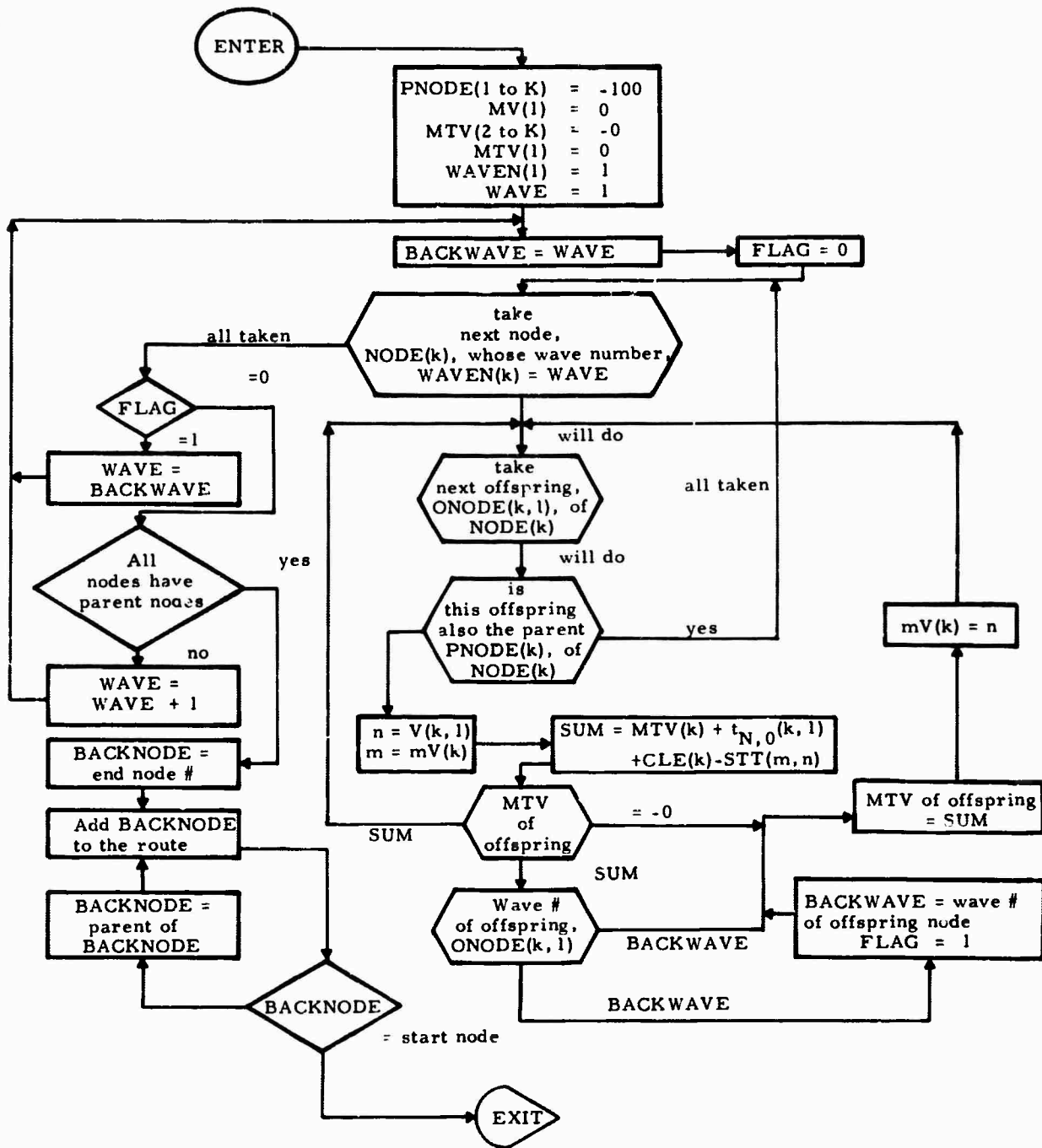

Figure 9. Detailed Flow Diagram for Dynamic Subroutine

A PENDING B

TRANSPORTATION NETWORK CHARACTERIZATION

This section is directed to the problem of determining, for a transportation network, the optimum paths through the network. The optimality may be, in general, expressed in such terms as: maximum cost, minimum time, maximum economic benefit, acceptable cost, etc. Without loss of generality, the following discussion is oriented toward the determination of the optimal minimum value of a selected set of network descriptors and the optimal route(s) yielding the optimal value.

THE PROBLEM

Definition 1

A transportation network will consist of a set of N nodes $\{x_i\}$ interconnected by elemental links t_{ij} between nodes x_j and x_i . The elemental link t_{ij} passes through no intermediate nodes

Definition 2

A transportation system network will consist of the same set of N nodes of the transportation network interconnected by the links t_{ij} , but with additional descriptors C_{ij}^k between nodes x_j and x_i where C_{ij}^k describes the generalized transit cost of vehicle k from node x_j to node x_i . In general, when routes include no intermediate nodes, it will not be possible for vehicle k to travel directly from every node x_j to all nodes x_i . The transit cost C_{ij}^k may be simply actual cost or transit time, or a more complicated expression including both, and social and political factors, etc.

Comment

Both of the above definitions are concerned with primary or basic links. Obviously, even with a minimal network connectivity, it should be possible to go from one node (via some set of nodes) to any specified node.

The links t_{ij} may be described, for some purposes, simply by Boolean functions (0 or 1) to indicate the absence or presence of an acceptable (according to some criteria set) link from node x_j to node x_i ; for other purposes, the link t_{ij} may carry descriptors such as length, width, load limits, terrain/road type, maintenance level, seasonal effects, etc. It is this latter description which is used in conjunction with the character-

istics of vehicle k in order to describe the elemental transit time t_{ij}^k of the transportation system network description.

Optimization

The problem is to minimize the cost function C_{ij}^k and to determine the route(s) yielding that minimum value. For simplicity in description, we will now assume that the cost function C_{ij}^k is given by the time t_{ij}^k .

The general problem could involve restrictions on the maximum flow rate on any link. However, in this present description of the problem (with only one active demand node) such restrictions are included in the elemental transit times. The flow rate restriction would come into play when the next order of complexity is introduced into the problem; that is, the problem of determining the optimal placement of resources to satisfy two or more simultaneous supply demands.

The shipping costs C_{ij}^k can be a complex function, depending upon the specific requirements of the problem. A composite function of time and economic factors could be developed and applied. If the transit time requirement were rigid, then the analysis could be performed first using t_{ij}^k as the elemental cost function, and this could be followed by the use of costs and other economic and political factors to select the best routes from whatever alternatives exist.

APPROACH

The minimum time, T_{ij} , required to go from node x_j to node x_i along any allowable path (usually via intermediate nodes) will first be determined, and then the route(s) which yield that minimum will be determined. This procedure will minimize the amount of computer memory which otherwise would have to be used (e.g., such as keeping track of the route during the optimization procedure). The procedures will allow an arbitrary number of elemental link times to be absent (infinite, or non-allowable), and to be symmetric or unsymmetric. The transit time across a node may have any value; the following derivations use the value zero. It is assumed that optimization over the vehicle set is to be performed using the minimum time (cost) matrices and routes determined for each vehicle; consequently the index k is suppressed in the following derivations.

DETERMINATION OF (T)

When there are N nodes with unsymmetrical transit times ($t_{ij} \neq t_{ji}$), $N^2 - N$ transit times T_{ij} must be evaluated. (When there is no dependence upon direction, this requirement is halved.) A direct approach would be to evaluate all of the possible paths between two nodes, selecting the minimum. An inordinate amount of computation is involved in this approach, as is easily demonstrated.

Consider N nodes in which it is potentially possible for any node to be connected to any other node. Then, selecting any two nodes there are $(N-2)!$ possible paths utilizing all remaining nodes (because the $N-2$ nodes may occur in any order); there are $(N-3)! \times \frac{(N-2)!}{(N-3)!}$ possible paths utilizing all but one intermediate node, etc. Finally, there may be one direct path between the nodes in question.

Using the binomial coefficients,

$$C_m^n = \frac{n!}{m!(n-m)!} \quad (1)$$

The number of possible paths is given by ($0! = 1$)

$$n_p = \sum_{j=0}^{N-2} C_j^{N-2} (j)! = (N-2)! \sum_{m=1}^{N-2} \frac{1}{(N-2-m)!} \quad (2)$$

and for large N ,

$$n_p \approx e(N-2)! \quad (3)$$

so that $eN!$ terms must be evaluated to determine T .

The number of arithmetic operations grows even more rapidly; the number of summation operations required for each term is equal to the number of intermediate nodes. Clearly, this simple approach is inefficient for any but the most simple cases.

A better approach is given by the utilization of the dynamic programming principles introduced by Bellman. Let the nodes be numbered from 1 to n , and let N be the set of all integers between 1 and n ,

$$N = \{1, 2, \dots, n\}. \quad (4)$$

Now, T_{ik} is the minimum transit time from node x_k to node x_i , considering all possible paths and intermediate nodes in the network. Clearly, this is expressed by (since $t_{ii} = 0$),

$$T_{ik} = (1 - \delta_k^i) \min_j \{t_{ij} + T_{jk}\}; i, j, k \in N \quad (5)$$

where δ_k^i is the usual Kronecker delta function.

Unfortunately, this expression involves the minimum transit times of all other nodes, and would be most difficult (if not impossible) to solve directly for the general problem being considered here. Let us therefore consider a sequential estimation process, which finds minima only over some subsets of the set of all possible paths. We first define the forward partial minimum time, \hat{t}_{jn} , to represent the minimum time from node x_n to node x_j when the routes are constrained to pass only through nodes with index greater than j . Then, it is clear,

$$\hat{t}_{jN} = \min \left\{ t_{jN}, \left(t_{j, j+1} + \hat{t}_{j+1, N} \right), \dots \right. \\ \left. \left(t_{j, N-1} + t_{N-1, N} \right) \right\} \quad (6)$$

is evaluated first for $j = N-1$, then for $j = N-2$, etc. down to j . It is evident that the $\{\hat{t}_{jN}\}$ represent only partial minima, in general, since the minimum time route from node x_N to x_j may, in fact, pass through a different sequence of nodes than those considered, or may pass through one of the nodes with index less than j . Equation (6) may be written more compactly as

$$\hat{t}_{ik} = \left(1 - \delta_k^i \right) \min_j \left\{ t_{ij} + \hat{t}_{jk} \right\}; j > i \quad (7)$$

which starts initially with $\hat{t}_{Nk} = t_{Nk}$, for $i = N, N-1, \dots, 1$.

Let us now define the reverse partial minimum time t_{ik}^* by

$$t_{ik}^* = \left(1 - \delta_k^i \right) \min_j \left\{ \hat{t}_{ik}, \left(t_{ij} + t_{jk}^* \right) \right\}; j < i \quad (8)$$

starting with $t_{ik}^* = \hat{t}_{jk}$, for $i = 1, 2, \dots, N$. This reverse process utilizes the previously obtained partial minimum \hat{t}_{ik} , and then considers additional routes through heretofore unconsidered nodes. When we get to $i = N$, not all routes have been considered, because each process (separately) was incomplete. We now use the \hat{t} procedure

again, starting with $\hat{t}_{Nk} = t_{Nk}^*$, in the form

$$\hat{t}_{ik} = (1 - \delta_k^i) \min_j \left\{ t_{ik}^*, \{t_{ij} + \hat{t}_{jk}\} \right\}, j > i \quad (9)$$

We now iterate with equations (8) and (9) until $\hat{t}_{ik} = t_{ik}^*$, when we have:

$$T_{ik} = \hat{t}_{ik} = t_{ik}^* \quad (10)$$

This may be easily proved, and can be stated as a theorem:

Theorem

If, for all i,

$$\hat{t}_{ik} = t_{ik}^* \quad (11)$$

then

$$T_{ik} = \hat{t}_{ik} = t_{ik}^* \quad (12)$$

Proofs

Two different proofs will be given. First, if (11) is to be true then (9) becomes

$$\begin{aligned} \hat{t}_{ik} &= (1 - \delta_k^i) \min_j \left\{ t_{ik}^*, \{t_{ij} + \hat{t}_{jk}\} \right\}; j > i \\ &= (1 - \delta_k^i) \min_j \{t_{ij} + \hat{t}_{jk}\}; j > i \end{aligned} \quad (13)$$

since \hat{t}_{ik} must be one of $\{t_{ij} + \hat{t}_{jk}\}$. Similarly, equation (8) becomes

$$t_{ik}^* = (1 - \delta_k^i) \min_j \{t_{ij} + t_{jk}^*\}; j < i \quad (14)$$

Proof A

Substitute for \hat{t}_{jk} in (13) from (11). We then have, combining (13) and (14), for all i and j,

$$t_{ik}^* = (1 - \delta_k^i) \min_j \{t_{ij} + t_{jk}^*\}, \quad (15)$$

since the equation is correct for i - j. But (15) is the same equation set as (5). Therefore

$t_{ik}^* = t_{ik} = T_{ik}$, since multiple solutions to (7) cannot exist.

Proof B

Suppose that, for some i, say $i = 1$, $\hat{t}_{1k} > T_{1k}$. (\hat{t}_{1k} cannot be less than the minimum, T_{1k} .) Now, the true minimum must be one of the terms $\{t_{1j} + T_{jk}\}$, say for $j = J$. Then we must also have $\hat{t}_{Jk} > T_{Jk}$, since $\hat{t}_{1k} = t_{1k}^*$. For $J = k$ this is clearly impossible, since $T_{kk} = t_{1k} = \hat{t}_{kk} = t_{kk}^* = 0$. Since J does not equal k , using the same argument, there must exist a J' such that $\hat{t}_{J'k} > T_{J'k}$. Again, if $J = k$, we have a contradiction, so there must exist a J'' such that $\hat{t}_{J''k} > T_{J''k}$, etc. Now, $j \in N$, which is a finite set. Thus, eventually we must arrive along the route at a node which connects directly with node k ; in this case, we have $j = k$ and we require $(t_{ik} + \hat{t}_{kk}) > (t_{ik} + T_{kk})$ which requires $\hat{t}_{kk} > T_{kk}$ or $0 > 0$ which is a contradiction. Thus the theorem is true.

There remains the question of whether the process will actually converge to the point where $\hat{t}_{ik} = t_{ik}^*$. Consider equation (9) at some step in the process. Clearly, (9) demands that $\hat{t}_{ik} \leq t_{ik}^*$. The next process, using (8), requires $t_{ik}^* \leq \hat{t}_{ik}$. Thus a bounded non-increasing sequence of values is established for every t_{ik}^* . The possibilities are finite in number, with the lower bound given by the actual minimum value T_{ik} . If equality does not exist after a given pass, then at least one t (or \hat{t}) must change in each next pass, or equality would then exist for all terms and the foregoing theorem applies. The process must therefore converge, but no estimate is readily derivable for the rate of convergence.

EXAMPLE

Suppose that we have a 4-node unsymmetrical transportation network given by:

$$(t) = \begin{bmatrix} 0 & t_{12} & t_{13} & t_{14} \\ t_{21} & 0 & t_{23} & t_{24} \\ t_{31} & t_{32} & 0 & t_{34} \\ t_{41} & t_{42} & t_{43} & 0 \end{bmatrix} \quad (16)$$

We wish to find the minimum transit time matrix

$$(T) = \begin{bmatrix} 0 & T_{12} & T_{13} & T_{14} \\ T_{21} & 0 & T_{23} & T_{24} \\ T_{31} & T_{32} & 0 & T_{34} \\ T_{41} & T_{42} & T_{43} & 0 \end{bmatrix} \quad (17)$$

As defined above, the forward partial minima \hat{t}_{ij} are given by the following scheme:

$$\left. \begin{aligned} \hat{t}_{34} &= t_{34} \\ \hat{t}_{24} &= \min \{t_{24}, t_{23} + \hat{t}_{34}\} \\ \hat{t}_{14} &= \min \{t_{14}, t_{12} + \hat{t}_{24}, t_{13} + \hat{t}_{34}\} \end{aligned} \right\} (18)$$

Then,

$$\left. \begin{aligned} t_{14}^* &= \hat{t}_{14} \\ t_{24}^* &= \min \{\hat{t}_{24}, t_{21} + t_{14}^*\} \\ t_{34}^* &= \min \{\hat{t}_{34}, t_{32} + t_{24}^*, t_{31} + t_{14}^*\} \end{aligned} \right\} (19)$$

thereby achieving the first estimate minimum transit time column vector (since T_{44} is, in this example, zero). After successive passes have found the minimum, this must be repeated for each column of the array. For example, the initial estimate for the third column is given by

$$\left. \begin{aligned} \hat{t}_{43} &= t_{43} \\ \hat{t}_{23} &= \min \{t_{23}, t_{24} + \hat{t}_{43}\} \\ \hat{t}_{13} &= \min \{t_{13}, t_{12} + \hat{t}_{23}, t_{14} + \hat{t}_{43}\} \\ t_{13}^* &= \hat{t}_{13} \\ t_{23}^* &= \min \{\hat{t}_{23}, t_{21} + t_{13}^*\} \\ t_{43}^* &= \min \{\hat{t}_{43}, t_{42} + t_{23}^*, t_{41} + t_{13}^*\} \end{aligned} \right\} (20)$$

Suppose that we now consider a numerical example. Then, if (as indicated in the figure below).

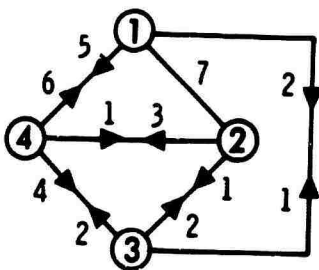

Figure 1. 4-Node Example

$$(t) = \begin{bmatrix} 0 & 7 & 1 & 6 \\ 7 & 0 & 1 & 1 \\ 2 & 1 & 0 & 4 \\ 5 & 3 & 2 & 0 \end{bmatrix} \quad (21)$$

we have

$$\left. \begin{aligned} \hat{t}_{34} &= 4 \\ \hat{t}_{24} &= \{1, 4 + 2\} = 1 \\ \hat{t}_{14} &= \{6, 7 + 1, 4 + 1\} = 5 \\ t_{14}^* &= 5 \\ t_{24}^* &= \{1, 5 + 7\} = 1 \\ t_{34}^* &= \{4, 1 + 1, 1 + 5\} = 2 \\ \hat{t}_{34} &= 2 \\ \hat{t}_{24} &= \{1, 2 + 2\} = 1 \\ \hat{t}_{14} &= \{5, 7 + 1, 1 + 2\} = 3 \\ t_{14}^* &= 3 = T_{14} \\ t_{24}^* &= 1 = T_{24} \\ t_{34}^* &= 2 = T_{34} \end{aligned} \right\} (22)$$

so that two complete passes were necessary.

The program logic is shown in figure 1, where the function F remains equal to 1 after one complete pass only if $t_{ik} = t_{ik}^*$.

ALTERNATE PROCEDURE

It is clear that the division of the computational procedure into separate t and t^* subroutines is artificial, and could be combined into a single procedure. Suppose we denote the m th estimate of the minimum time by $t^*(m)$. Then, combining (8) and (9) we have, for $i, j, k \in N$,

$$t_{ik}^*(m) = \min_j \left\{ t_{ik}^*(m-1), \left\{ t_{ij}^* + t_{jk}^*(m-1) \right\} \right\} \quad (23)$$

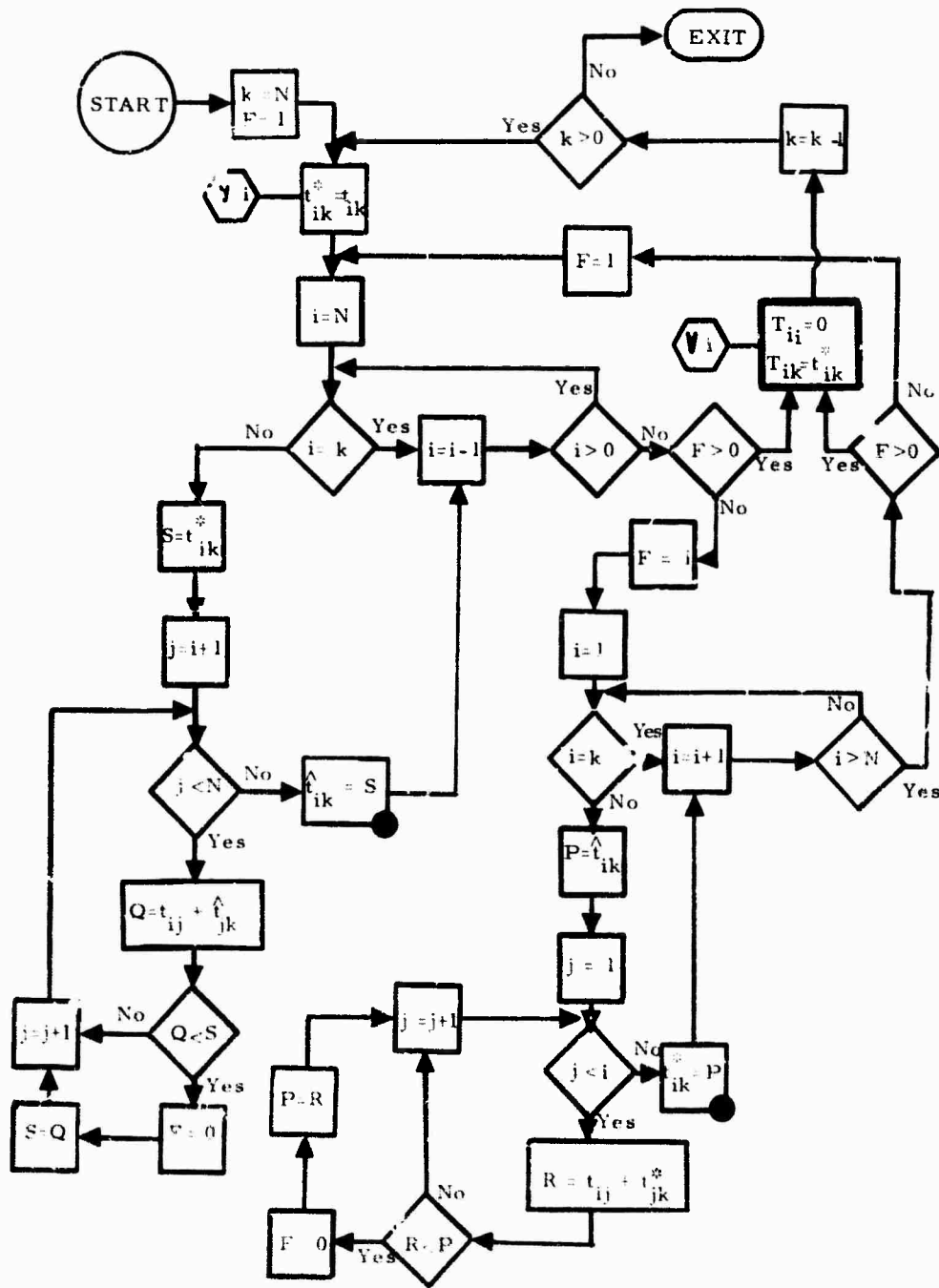

Figure 2. Program Logic

or in a more compact form (since $t_{ii} = 0$).

$$t_{ik}^{(m)} = \min_j \{ t_{ij} + t_{jk}^{(m-1)} \} \quad (24)$$

with the initial value

$$t_{ik}^{(1)} = t_{ik} \quad (25)$$

Clearly, the previous theorem applies, so that the process (24) is completed with

$$T_{ik} = t_{ik}^{(m+1)} = t_{ik}^{(m)}, \quad \forall i \quad (26)$$

Clearly also, the process (24) can utilize $t_{jk}^{(m)}$, instead of $t_{jk}^{(m-1)}$, whenever it has been evaluated. The simplified program logic of Figure 2 then results. Approximately the same number of

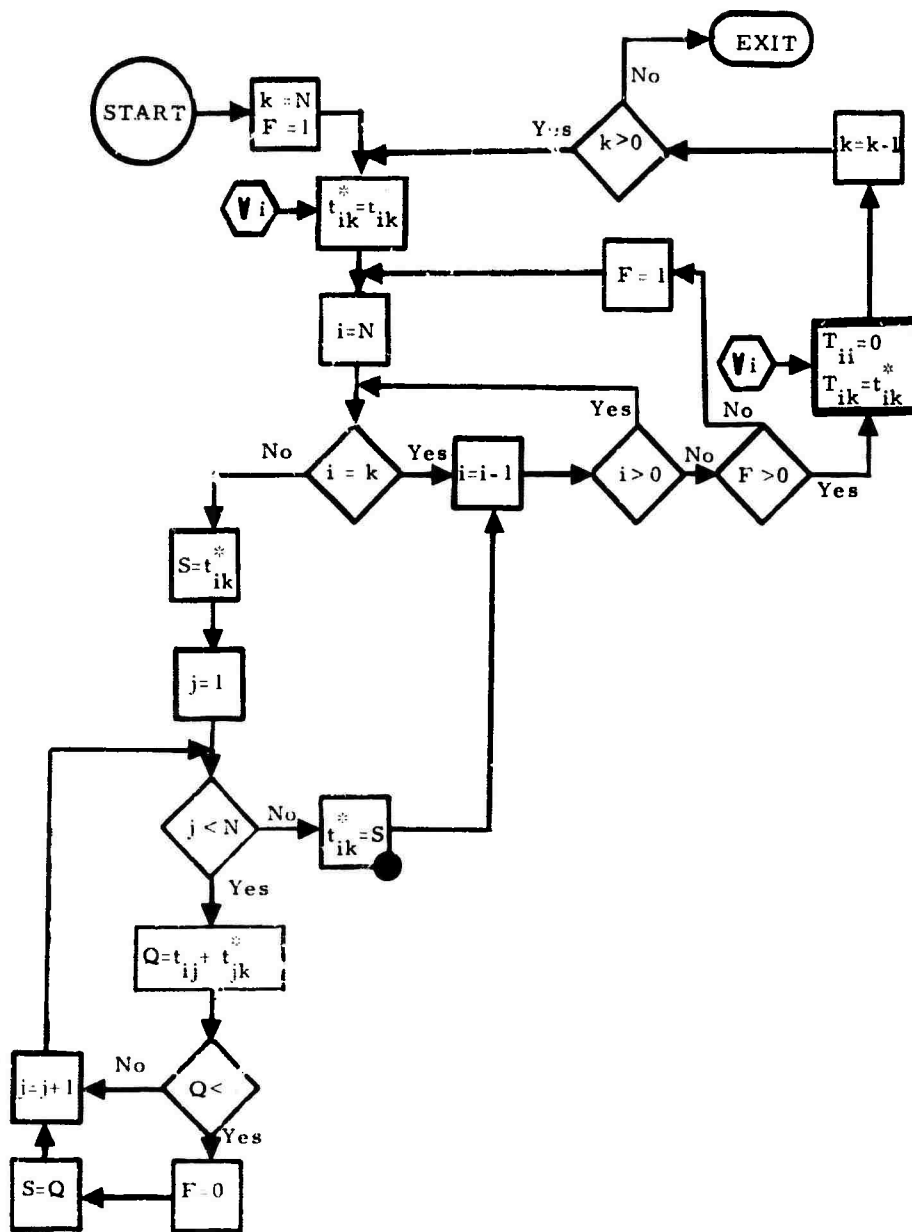

Figure 3. Simplified Program Logic

iterations will be involved as in the previous logic of Figure 1.

Comment

Whenever networks do not have an extremely high connectivity (i. e. nearly every node connected to another node), the number of computational steps can be reduced in the early steps of the process. We are interested in determining the minimum transit time between nodes, and have been implicitly assuming that impossible or impractical transit times in the elemental matrix (t) were represented by some large number, say t_M . Many of the comparisons in (24) will involve such

values; therefore the process might be speeded up by eliminating such comparisons. At any step in the process we can define a characteristic function

$$C_m(j) = 1 \text{ if } t_{jk}^{(m)} < t_M \quad (27)$$

$$= 0 \text{ otherwise}$$

and solve

$$t_{ik}^{(m)} = \min_i \left\{ t_{ik}^{(m-1)}, \left[t_{ij} + t_{jk}^{(m-1)} \right] C_{m-1}(j) \right\} \quad (26)$$

which requires fewer operations in the initial steps of the process. However, for the latter stages, an additional test has been introduced, adding to the total number of steps in the process. If the program is written in machine language, (28) could be utilized effectively; otherwise, (24) has probably the same order of running time as (28).

DETERMINATION OF ROUTE

Once the minimum time (cost) matrix T is determined, and independently of how it is determined, the determination of the route(s) corresponding to the minimum can be easily obtained. The set J_{ik}^* given by

$$J_{ik}^* = \left\{ j \in N \mid T_{ik} = (1 - \delta_j^i) \min_j \left[t_{ij} + T_{jk} \right] \right\} \quad (29)$$

contains only those values of j which yield the minimum, T_{ik} ; the nodes x_j , $j \in J_{ik}^*$, therefore immediately precede x_i on the minimum route from node x_k . This evaluation performed for all elements of the k^{th} column of the matrix will yield the number of the preceding node(s) on the minimum route to each element from node x_k .

In the example given previously, suppose that the minimum route from node x_4 to node x_1 is desired. We have (see equation 22).

$$\begin{aligned} 3 &= T_{14} = \min_j \left\{ t_{14}, t_{13} + T_{34}, t_{12} + T_{24} \right\} \\ &= \min \left\{ 6, 1 + 2, 7 + 1 \right\}; \quad J_{14}^* = \{3\} \\ 1 &= T_{24} = \min_j \left\{ t_{24}, t_{23} + T_{34}, t_{21} + T_{14} \right\} \\ &= \min \left\{ 1, 2 + 2, 7 + 3 \right\}; \quad J_{24}^* = \{4\} \\ 2 &= T_{34} = \min_j \left\{ t_{34}, t_{32} + T_{24}, t_{31} + T_{14} \right\} \\ &= \min \left\{ 4, 1 + 1, 2 + 3 \right\}; \quad J_{34}^* = \{2\} \end{aligned} \quad \left. \vphantom{\begin{aligned} 3 &= T_{14} \\ 1 &= T_{24} \\ 2 &= T_{34} \end{aligned}} \right\} (29)$$

So that, for routes starting from node x_4 , there exist only single element sets, J_{i4}^* . We have therefore found that the minimum route from x_4 to x_1 passes directly from x_3 to x_1 . The minimum route to x_3 from x_4 comes via x_2 , and goes directly from x_4 to x_2 . The route is thus 4, 2, 3, 1.

Data Handling

The manner in which this information is to be utilized will determine the form in which a computer program should retain or print out the data.

Map Printouts - Choose a node x_k . Then, for each node x_i , blacken the segment between x_i and each node x_j with $j \in J_{ik}^*$, and associating the minimum time T_{ij} with each segment.

Numerical Printout - Print the values $j \in J_{ik}^*$ for all i and k . It would also be possible to print each route, but the information would not be presented in a compact form. Also print the T_{ij} matrix.

Minimal Cost and Time Routes

Assuming that several minimum time routes exist, the route(s) with minimum cost may be selected by direct enumeration, or more generally, by application of the same program used previously to determine minimum time. In this latter case, suppose we wish to find the minimum cost routes from node x_k to all nodes x_i , knowing the sets J_{ik}^* for all i . Then, we establish a cost matrix C_{ij} for these links t_{ij} with $j \in J_{ik}^*$, filling in arbitrary large values for those links which do not have the property that $j \in J_{ik}^*$. We then use the foregoing minimizing procedure and the route specification procedure. Note that this process would have to be applied N times; once for each node as a source node (although some of the computations will be redundant.)

APPENDIX C

THE SECURITY STATION PROBLEM

The mathematical basis of the security station problem is a generalization of the usual transportation problem of operations research. The problem is conveniently treated in steps of increasing complexity.

$$y_{0i} \equiv \sum_{j=1}^{n_2} y_{LO_{ij}} \theta(t_R - t_{ij})$$

giving a total left-over (slack) variable for shipment to the i -th node. So we have finally

BASIC SINGLE-NEED PROBLEM

The simplest problem considered is that of supplying any point in the network with some units of "resources", where only one point need be supplied at any one time. Let the possible allocation points or supply node points be labeled by $j = 1, 2, \dots, n_2$. If Δy_{ij} is the unknown amount of resources slipped from j to i , and N_i is the total amount needed at each node, $i = 1, 2, \dots, n_1$, then

$$\sum_{j=1}^{n_2} \Delta y_{ij} \theta(t_R - t_{ij}) = N_i \quad (1)$$

is a set of n_1 equations describing the scheduling. Here $\theta(t_R - t_{ij})$ is a step function such that the transit time t_{ij} must be less than the reaction time t_R :

$$\theta(x) = 1, \quad x > 0$$

$$\theta(x) = 0, \quad x < 0.$$

We now express the Δy_{ij} in terms of the total allocation available at j ($= y_j$) and a left-over (not shipped) part ($= y_{LO_{ij}}$)

$$\Delta y_{ij} = y_j - y_{LO_{ij}}$$

Then we have

$$\sum_{j=1}^{n_2} y_j \theta(t_R - t_{ij}) - \sum_{j=1}^{n_2} y_{LO_{ij}} \theta(t_R - t_{ij}) = N_i \quad (2) \quad \text{where}$$

$$j = 1, 1, \dots, n_2$$

The details of the left-over shipments can be harmlessly suppressed:

$$\sum_{j=1}^{n_2} y_j \theta(t_R - t_{ij}) - y_{0i} = N_i \quad i=1, \dots, n_1 \quad (3)$$

which are n_1 equations in $n_1 + n_2$ variables, to be solved so that the total of the allocations is a minimum:

$$T = \sum_{j=1}^{n_2} y_j \quad (\text{to be minimized}) \quad (4)$$

This problem (equations 3 and 4) can be solved by the Simplex method, finding an obvious basic feasible solution (n variables zero, n non-zero) and then exchanging non-zero and zero-valued variables so that T is decreased the most possible at each step.

MULTIPLE-NEED PROBLEM

For only shipment to one need point at a time, equation 1 is sufficient. For shipments to any n_1 need points at a time, the total shipped must be restricted to be less than the allocation, or

$$\sum_{i=1}^{i_2} \theta_{ij} \Delta y_{ij} - y_j \leq 0 \quad (5)$$

and

$$i_j = 1, 2, \dots, n_i$$

$$i_2 > i_1, i_2 = 2, \dots, n_i$$

and the sum in equation (2) is restricted such that

$$\sum_{i=i_1}^{i=i_2} = n'_i$$

Equations (1) and (5) can now be solved, with T as given in Equation (4) to be maximized. The "left-over" supply variables can again be combined into a smaller number of slack variables, as before.

INCLUSION OF TRANSPORT COSTS

If transport costs are to be included, then the cost function is changed to

$$T = \sum_j y_j + \sum_{ij} c_{ij} \Delta y_{ij}, \quad (6)$$

where the c_{ij} are the transportation costs (here normalized to unit purchase costs) of transporting goods from j to i .

Equations (1) and (5) are still the required set of equations in terms of Δy_{ij} . Note that when transport costs is neglected, the shipment details Δy_{ij} can be lumped together and used as a slack variable; such is not possible here.

Now i_1 and i_2 can represent any indices, in general, depending on the "response" wanted. For the usual transportation case

$$i_1 = 1$$

$$i_2 = n_i$$

and it follows that

$$\sum_j y_j = \sum_i N_i$$

so that the inequality in (5) becomes an equality.

THE INTEGRAL UNIT PROBLEM

It is of interest to be able to require only whole number solutions to the stationing problem, so that, say, 1-2/3 men will not be sent to meet a security threat. This problem can be considered a special case of the minimum station problem, treated below.

The "Minimum Station" Problem

It may be more useful to minimize not just the total number of security units required, but rather the total cost of units plus a fixed cost for every station. The result, for very large stationing costs, is the same as a minimum station problem.

The fixed station-cost ("minimum stations") problem can be written down as follows:

$$\text{Minimize } T = \sum_j y_j + k \sum_j \delta_j$$

where δ_j is 0 or 1 depending on whether y_j is zero or non-zero, and k is the fixed costs per occupied stations, the y_j , as usual, are the allocations dollars. To use the Gomory method employed by the ILP-2 program, the y_j must be integers; otherwise other methods must be employed.

The constraint equations are

$$\sum_{ij} c_{ij} y_j \geq N_i \quad (7)$$

plus the conditions on the δ_i :

$$\delta_i + \epsilon_i = 1, \epsilon_i \geq 0 \quad (8)$$

restricting δ_i to be less than or equal to 1, and the further condition

$$y_i - P \delta_i \geq 0 \quad (9)$$

where P is any positive integer conveniently chosen to be a maximum "guess" for y_i . Condition (3) insures that

$$\delta_i = 0 \text{ whenever } y_i = 0.$$

The last conditions are

$$\delta_i = \text{integer} \quad (10)$$

so that δ_i can be only 0 or 1, and (to apply the Gomory method) we require

$$y_i = \text{integer} \quad (11)$$

Now one proceeds as outlined above to find δ_i and y_i such that T is a minimum.

For $\delta_i \equiv 0$, the problem reduces to the integral station situation mentioned above.

Special Treatments

For the most interesting class of cases, the stationing problem need not be solved by the relatively cumbersome linear programming methods given here. A simpler method for these cases is described in Appendix D.

APPENDIX D

ALLOCATION OF RESOURCES TO MINIMUM SUPPLY DEPOTS

INTRODUCTION

We wish to consider a special kind of resource allocation - the problem of determining the placement of resources such that they may be shipped to any using point within a specified time and within a specified cost. The optimality has several facets; we may wish also to minimize the shipping costs, and we desire the solutions requiring the minimum number of storage depots for the resources. The solutions which require a minimum number of storage depots may (because of fixed installation costs, maintenance costs, inventories, food, housing, political factors, etc.) be the most cost effective solutions.

Suppose that there is a demand for resources at node x_i given by q_i and that resource Q_i is to be stored at node x_j . Further, suppose that the demand of q_i at node x_i must be satisfied within a time t_R . The first order time-optimum resource allocation consists of locating Q_i at locations x_{j^*} , with the minimum $\sum Q_{j^*}$ which will satisfy the demand at any one x_i within the time t_R . Note that here only one node x_j must be supplied at any one time, but that the system must be capable of supplying all nodes x_i in this manner.

Higher order resource allocations require satisfaction of demands at several x_i simultaneously. Only the first order resource allocation problem will be considered in detail here, and will be based upon the time optimum problem. The extensions to more general cost functions are obvious.

APPROACH

Once the minimum time matrix T is determined, linear programming could be utilized to determine a solution to the minimum resources required and the location of those resources. Successive trials with different initial conditions might drive out additional solutions, but there does not appear to be any way, using linear programming, to ensure the generation of all solutions.

However, a novel approach has been developed which utilizes Boolean switching function theory and seems to possess merit and a definite usefulness for the solution of problems of this type. The approach can be summarized in the following steps. It is first assumed that all network nodes are allowable supply nodes and all nodes are demand nodes.

- (1) Determine, from the minimum transit time matrix (T_{ij}), the nodes which can supply demand node x_i within a specified reaction time. Repeat for all demand nodes x_i .

- (2) Express the supply-demand relationships in symbolic logic format. For example: Node 1 can be supplied by node 3 or by node 5 or by ..., etc.
- (3) Since each node is a demand node, all of the relationships of (2) above must be satisfied (must be true).
- (4) Determine all combinations of supply nodes which satisfy (3).

Mathematical Formulation

In more mathematical terms, we can summarize the process in the following fashion:

- (1) Start with the basic minimum transit time matrix (T_{ij}).
- (2) Define the Boolean switching function matrix \hat{T} by $\hat{T} = (\theta_{ij})$, with

$$\theta_{ij} = \mu(t_R, T_{ij}) \quad (1)$$

where

$$\mu(t_R, T_{ij}) = \begin{cases} 1 & \text{if } T_{ij} \leq t_R \\ 0 & \text{if } T_{ij} > t_R \end{cases} \quad (2)$$

is a selector function, and t_R is the required reaction time to node x_i . The matrix T describes the reachable nodes.

- (3) Define the Boolean variables y_i and b_i as follows:

$$y_i = \begin{cases} 1 & \text{if node } x_i \text{ is a depot} \\ 0 & \text{otherwise} \end{cases} \quad (3)$$

$$b_i = \begin{cases} 1 & \text{if node } x_i \text{ is a demand node} \\ 0 & \text{otherwise} \end{cases} \quad (4)$$

- (4) The problem is now transformed into the problem of solving the Boolean matrix equations (\sum is a Boolean logic sum; i.e., $\sum a_i = a_1 + a_2 + \dots$, where $+$ signifies the logic operator "or").

$$\sum_{j=1}^N \theta_{ij} y_j = b_i, \quad i=1, \dots, N \quad (5)$$

for those combinations of $y_i = 1$ which yield $b_1 = b_2 = \dots = b_N = 1$. That is, which depots must be activated in order to be able to supply all demand points? Note that all possible solutions to the problem will be selected; we can then subsequently select the minimum number of depots, or (upon evaluation of resources required) the solution requiring the minimum total resource.

(5) Now each of the N equations,

$$\sum_{j=1}^N \theta_{ij} y_j = b_i \quad (6)$$

must be satisfied (i.e., each $b_i = 1$) by a Boolean solution vector y_j . We thus can combine the equations to

$$\begin{pmatrix} \sum_{j=1}^N \theta_{1j} y_j \\ \sum_{j=1}^N \theta_{2j} y_j \\ \vdots \\ \sum_{j=1}^N \theta_{Nj} y_j \end{pmatrix} = \begin{pmatrix} b_1 \\ b_2 \\ \vdots \\ b_N \end{pmatrix} = \mathbf{F} = 1 \quad (7)$$

(6) We now simply convert the Boolean function F into its minimum sum of products form, and each of the logical products is a solution. (In switching theory nomenclature, we simply ask for the set of all prime implicants of F . Each prime implicant is a solution vector.)

EXAMPLE

The process is best illustrated by the consideration of an example. Consider the 7-node network shown below in Figure 1. The numbers on the links represent the elemental transit times t_{ij} . (e.g., $t_{47} = 6$.) The matrix T is developed by the method discussed in appendix B, and is indicated in Figure 2.

If there is no time restriction imposed, then clearly any node will satisfy the requirement of being able to supply all other nodes. Nodes x_2 , x_4 , and x_6 as supply nodes each have the property of requiring the minimum average time to supply all other nodes. The various Boolean matrices T for restricted reaction times t_{R_i} are indicated in Figure 3.

Basic Solutions

Consider the case in which $t_R = 2$ (the transit time is required to be less than or equal to 2). The fundamental logic equation is then

$$(y_1 + y_2 + y_6)(y_1 + y_2)(y_3 + y_5)(y_4 + y_5)(y_3 + y_4 + y_5)(y_1 + y_6 + y_7)(y_6 + y_7) = F \quad (8)$$

where the + sign is the logical "or". F immediately reduces to

$$F = (y_1 + y_2)(y_5 + y_3 + y_4)(y_6 + y_7) \quad (9)$$

by virtue of the switching logic identity,

$$(x + y)(x + z) = x + yz \quad (10)$$

Thus, the solutions are:

$$y_1 y_5 y_6 \quad y_1 y_3 y_4 y_6 \quad (11)$$

$$y_2 y_5 y_6 \quad y_2 y_3 y_4 y_6$$

$$y_1 y_5 y_7 \quad y_1 y_3 y_4 y_7$$

$$y_2 y_5 y_7 \quad y_2 y_3 y_4 y_7$$

For $t_R = 3$, we have (in reduced form)

$$(y_1 + y_2 + y_6)(y_3 + y_4 + y_5)(y_6 + y_7) \quad (12)$$

and the solutions are

$$y_6 y_3 \quad y_1 y_3 y_7 \quad y_2 y_3 y_7 \quad (13)$$

$$y_6 y_4 \quad y_1 y_4 y_7 \quad y_2 y_4 y_7$$

$$y_6 y_5 \quad y_1 y_5 y_7 \quad y_2 y_5 y_7$$

For $t_R = 4$, we have (in reduced form)

$$(y_1 + y_2 + y_4 + y_6)(y_3 + y_4 + y_5)(y_1 + y_5 + y_6 + y_7) = F \quad (14)$$

The solutions are:

$$y_1 \quad y_4 y_6 \quad y_5 y_2 \quad (15)$$

$$y_1 y_4 \quad y_4 y_7 \quad y_2 y_3 y_7$$

$$y_1 y_5 \quad y_6 y_3$$

$$y_4 y_5 \quad y_6 y_5$$

Multiple Solutions

The largest compatible solutions are $y_1 y_4 y_5$ and $y_4 y_5 y_6$, each of which has the property that every pair is also a solution. (In effect, this is the application of a merger diagram.) The clear implication of this latter possibility is that in this case, and only in this case, is it possible to divide up resources among three depots such that at least two will be able to supply any demand node. Thus, if q is demanded at each node, the minimum station number is two, requiring a total resource of $2q$. However, with one of these

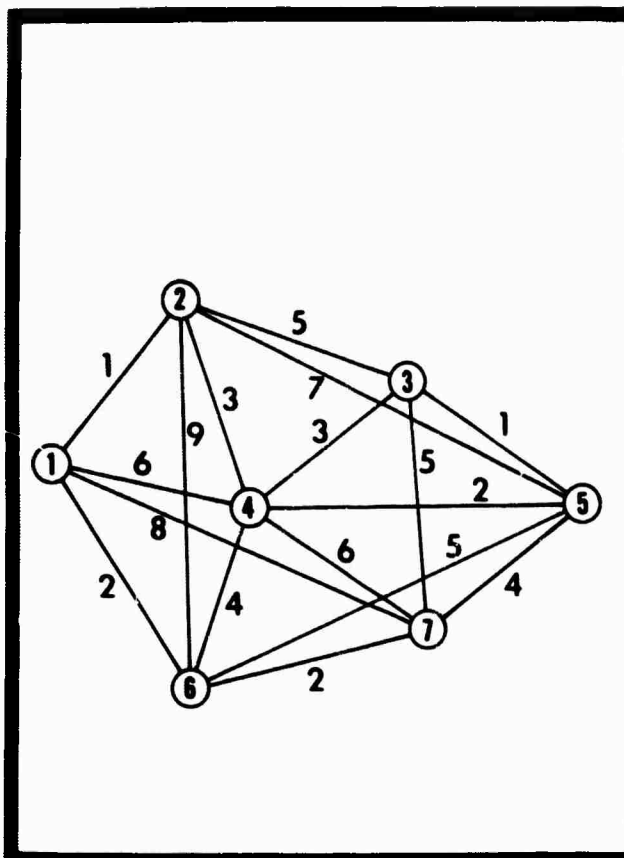

Figure 1. 7-Node Network Example

		Source Node						
		1	2	3	4	5	6	7
Demand Node	1	0	1	6	4	6	2	4
	2	1	0	5	3	5	3	5
	3	6	5	0	3	1	6	5
	4	4	3	3	0	2	4	6
	5	6	5	1	2	0	5	4
	6	2	3	6	4	5	0	2
	7	4	5	5	6	4	2	0

Figure 2. Minimum Transit Time T

		Source Node						
		1	2	3	4	5	6	7
Demand Node	1	1	1		1		1	1
	2	1	1	1	1	1	1	1
	3			1	1	1		1
	4	1	1	1	1	1	1	
	5			1	1	1	1	1
	6	1	1		1	1	1	1
	7	1	1	1		1	1	1

$$t_R = 5$$

		Source Node						
		1	2	3	4	5	6	7
Demand Node	1	1	1		1		1	1
	2	1	1		1		1	
	3			1	1	1		
	4	1	1	1	1	1	1	
	5			1	1	1		1
	6	1	1		1		1	1
	7	1				1	1	1

$$t_R = 4$$

		Source Node						
		1	2	3	4	5	6	7
Demand Node	1	1	1				1	
	2	1	1		1		1	
	3			1	1	1		
	4		1	1	1	1		
	5			1	1	1		
	6	1	1				1	1
	7						1	1

$$t_R = 3$$

		Source Node						
		1	2	3	4	5	6	7
Demand Node	1	1	1				1	
	2	1	1					
	3			1		1		
	4				1	1		
	5			1	1	1		
	6	1					1	1
	7						1	1

$$t_R = 2$$

Figure 3. Boolean \hat{T} Matrices

three station solutions, since it is assured that at least two depots will be able to supply every demand node, only $1/2 q$ is required at each depot, thereby demanding a total resource of $3 q/2$.

Thus, more generally, suppose that the minimum depot solution requires 2 depots. Then, letting M be a set of m nodes x_i such that every pair of nodes $x_i, x_j \in M, i \neq j$, comprise a 2-node solution to the problem, the minimum total resource required is $\frac{m}{m-1} q$.

Similarly, if (1) the minimum supply node solution is 3 nodes, and if (2) there exists a set M of m nodes $\{x_i\}$ such that every 3-tuple of nodes, $x_i, x_j, x_k \in M, i \neq j \neq k$, comprise solution to the problem, then the minimum total resource required is $\frac{m}{m-2} q$.

Consider, as an example, the proof of this relationship for $m=5$, with a 3-node minimum supply node solution. Suppose M consists of $\{x_1, x_2, x_3, x_4, x_5\}$. Consider one of the 3-node solutions, say x_1, x_2, x_3 . Then, in supplying at least one node x_i , two of the nodes must be unable to supply the node x_i . (Otherwise, the minimum node solution would be a two-node or a 1-node solution). For that node, x_i , both of the remaining nodes must be able to supply resources. (Otherwise, it would not be true that every 3-tuple constitutes a solution.) Thus, in supplying x_i , there are $3 = m-2$ active nodes, and the minimum total resource required there is $\frac{5}{3} q$. This must be true at all demand nodes x_i , and therefore the relationship is established for the network.

COMPUTING ALGORITHMS

We are interested in deriving computing algorithms which will implement the reduction process illustrated in the above example. It is therefore necessary to first consider a few concepts from switching theory.

A Boolean product term a subsumes another product term b if, and only if, a implies b (i.e., whenever a is true, b is true). In this case, $ab = a$, and b is said to cover a . For example, $a = xyz$ implies $b = xy$, and xy covers xyz . If both are present in a logical expression, $a + b$ can be reduced to b , since $a \subset b$. Using the same example, $xyz + xy = xy$. Now the usual dualism holds for Boolean sum terms. Let $a = (x+y)$ and $b = (x+y+z)$. Then a implies b , and $ab = a$, and ab can be reduced to a .

An efficient general process to find all of the solutions has not yet been found. However, it is relatively simple to construct a procedure capable of allowing one solution to be determined.

Approach

Observe first that not all equations are necessary. If one node is capable of being supplied by each one of a set of nodes, say A , and another node is capable of being supplied by a subset of A , then clearly the first node will automatically be able to be supplied whenever the second node is supplied. The first equation is

unnecessary, since it is implied by the second.

Once the subsumed equations have been eliminated, a reduced set of equations is left which contains all of the essential information content of the original set of equations. If we now examine this remaining equation set, it may be that there exists a node, say x_j , which can supply all of the nodes that can be supplied by another node, say x_k , and more. Then, if we are looking for only one solution, let us not consider any further node x_k , since x_j is at least as good a choice as x_k and might be better. Continuing in this fashion, a reduction in the set of supply nodes being considered is achieved.

The equations are next reexamined for subsuming relationships, then the possible supply node subsuming relationships are reexamined, etc., until the process is terminated when no further reductions are possible.

Nature of Solutions

The above process may arrive at a solution. If so, the solution is a minimum supply node solution by virtue of the process outlined above. (The proof of this relationship is somewhat complicated and has not been completed.) The reduced set may not have a unique solution evident. If so, pencil and paper methods may be used (as in the example considered previously) to find the minimum station solution.

Additional Solutions

Once one minimum node solution has been determined, it is a relatively simple matter, conceptually, to determine all of the minimum node solutions. If, for example, a three node solution is found, say $\{x_1, x_2, x_3\}$, and if a record has been kept of the supply node eliminations, then there is a semi-equivalence class of nodes for each of x_1, x_2 , and x_3 . A potential solution is a 3-node configuration in which one node is chosen from the x_1 - class, one node from the x_2 - class, and the third from the x_3 - class. The configuration is then tested to see if it satisfies the original problem.

Mathematical Formulation

Let us write the equation set as

$$f_i = \sum_{j=1}^N \theta_{ij} y_j$$

and

$$F = \prod_{i=1}^M f_i = \prod_{i=1}^M \sum_{j=1}^N \theta_{ij} y_j$$

where \sum and \prod are the logical sum and logical product symbols respectively. F must be solved for those combinations of $y_j = 1$ which make F true.

Clearly, if equation f_i implies equation f_j , then f_i may be eliminated. Let us treat f_i as a Boolean N -vector, and W as a Boolean $M \times 1$ vector with components ω_i defined by

$$\omega_i = \begin{cases} 1 & \text{iff } f_i \text{ is an active equation} \\ 0 & \text{otherwise} \end{cases}$$

Then we have the reduced function

$$F_1 = \prod_{i=1}^M (f_i)^{\omega_i}$$

where

$$\omega_i = \begin{cases} 0 & \text{iff } f_i f_j = f_j \text{ for some } j \\ 1 & \text{otherwise} \end{cases}$$

F_1 will consist of the product of $K \leq M$ factors as a result of this first reduction.

We now consider the supply nodes. Let Q be a Boolean N -vector with components q_j defined by

$$q_j = \begin{cases} 1 & \text{iff } y_j \text{ is an active supply node} \\ 0 & \text{otherwise} \end{cases}$$

and let S_j be the Boolean K -vector with components

$$s_j(i) = \omega_i \theta_{ij}$$

Then, clearly, if $S_j S_k = S_k$, supply node x_k may be ignored since node x_j can supply all of the nodes supplied by x_k and possibly more. Thus we have another reduced function

$$F_2 = \prod_{i=1}^M \left[\sum_{j=1}^N \theta_{ij} y_j q_j \right]^{\omega_i}$$

where

$$q_j = \begin{cases} 0 & \text{iff } q_j q_i = q_j \text{ for some } i \\ 1 & \text{otherwise} \end{cases}$$

The reduced set F_2 is now examined again for redundant factors f_i where

$$f_i = \sum_{j=1}^N \theta_{ij} y_j q_j$$

and a new vector W is determined. The process then continues until no further reduction is possible.

The resulting reduced set can be of several forms:

- (1) no solution: $q_j = 0$ all j
- (2) one solution: $q_j \neq 0$ for all j and if $q_j = 1$, only one node is supplied.
- (3) multiple solutions: Several $q_j = 1$ and can supply more than one node.

In cases (1) and (2) a single solution is determined. In case (3), a single solution may be obtained by pencil and paper procedures (similar to those used in the example).

Allowable Nodes

All nodes are allowable if initially the vectors W and Q are unit vectors (i.e., $\omega_i = 1$ and $q_j = 1$ for all i and j). Thus the allowable demand and supply nodes are simply established by the initial W and Q vectors.

$$\text{Allowable Demand Nodes} = \{x_i \mid \omega_i(0) = 1\}$$

$$\text{Allowable Supply Nodes} = \{x_j \mid q_j(0) = 1\}$$

APPENDIX F

NETSIM

COMPUTER PROGRAM DESCRIPTION

INTRODUCTION

The NETSIM program described in this appendix is one of the principal sub-programs required by the comprehensive SIMDATS simulation program described in Appendix A. The mathematical foundations for the subroutines described here have been described in Appendices B and D. The uses of the NETSIM program and the results obtained have been described earlier.

PROGRAM SUMMARY

The NETSIM simulation program consists of the executive NETSIM program and three called subprograms: DYNAMIC, JSTAR, and TCHEV. The specific function of this simulation program is to derive a number of significant transportation system network descriptors. Given a matrix of times (or, in general, costs) of links between connected nodes of a transportation network, the following parameters may be calculated:

(1) Subroutine DYNAMIC:

The matrix of minimum times (costs) from any node to any other node. There may be up to 100 nodes in the network with any degree of connectivity.

(2) Subroutine JSTAR:

- (a) The optimum route in terms of the JSTAR matrix giving those nodes on each minimum time (cost) route(s) which are just adjacent to the end node of the route(s).
- (b) A listing of network links never used on any optimum route.

(3) Subroutine TCHEV:

- (a) The \hat{t} matrix giving the possibility or impossibility of reaching each node from all other nodes within a given time (cost).
- (b) A minimum station solution for each specified minimum reaction time (cost) for each specified configuration of allowable "supply" and "demand" nodes.

The program operation is described in the following section, and then the executive routine and each subroutine are described in detail in separate sections. Each of these sections provides a set of

definitions of quantities used in the subprogram, a functional diagram, and a sample printout.

NETSIM EXECUTIVE PROGRAM DESCRIPTION

The function of the EXECUTIVE program is to read in all data cards, check input data for errors and terminate execution if error is found, store data in proper position in proper arrays, and call subroutines to operate on the data. Figure 1 gives an overall summary of the NETSIM program.

SUBROUTINE DYNAMIC DESCRIPTION

Given the matrix of connected node times (or costs) $[t_{ik}]$ in a network of N nodes, the matrix of minimum time $[T_{ik}]$ is calculated between all nodes using a multipass dynamic programming technique, as summarized in Figure 2.

Definitions

N The number of nodes in the network ($N \leq 100$).

$[t_{ik}]$ The input $N \times N$ matrix of times (or costs) between connected nodes. t_{ik} is the time from node k to i , and is set to a very large number if nodes k and i are not connected by a transportation link. (FORTRAN symbol is T1.)

$[\hat{t}_j]$ The forward $N \times 1$ partial minimum time matrix.

$[t_i^*]$ The reverse $N \times 1$ partial minimum time matrix.

$[T_{ik}]$ The output $N \times N$ matrix of minimum times between all nodes of the network. (FORTRAN symbol is T2.)

Output

Figures 3 and 4 are portions of typical printouts of this subroutine.

SUBROUTINE JSTAR DESCRIPTION

Given the time (cost) matrices $[t]$ and $[T]$ for a network of N nodes, the matrix of nodes $J = [J_{ik}^*]$ is determined. J_{ik}^* gives the node(s) which is (are) the immediate predecessor node(s) to node i on the minimum time (cost) route(s) from node k to node i . Those links which are

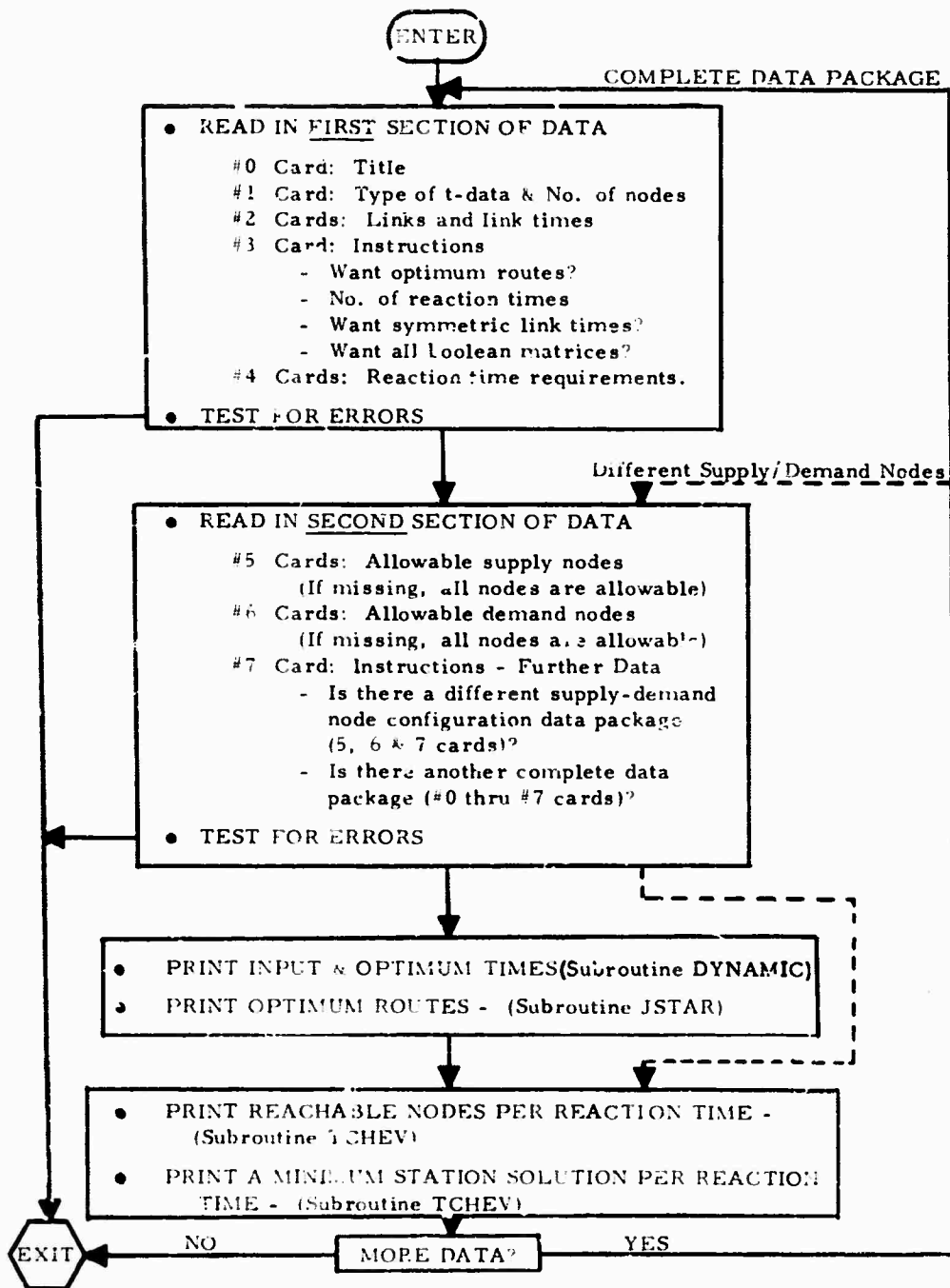

Figure 1. NETSIM Program Summary

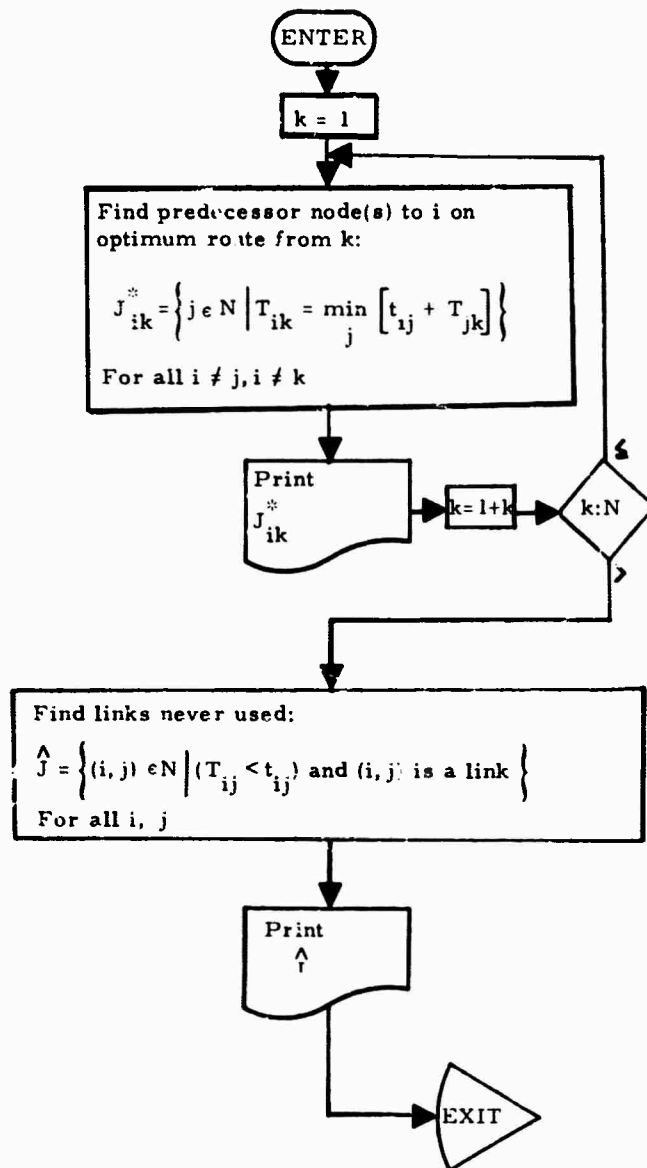

Figure 2. Functional Diagram for Subroutine JSTAR

PP JP WET 836AW697-24MINIUEM1,2,3,4,31,23,30,3,6,25,24,7,8,9,10

OPTIMUM MATRIX T2(1,J)

	J= 21	J= 22	J= 23	J= 24	J= 25	J= 26	J= 27	J= 28	J= 29	J= 30
1	82.12	98.12	22.35	53.32	107.75	95.02	169.61	59.19	40.20	117.65
2	75.44	91.94	15.97	45.84	101.07	88.34	162.93	52.51	33.52	110.97
3	150.45	166.45	72.70	42.47	74.10	163.35	230.35	127.52	108.53	146.80
4	88.76	84.76	8.99	39.36	94.39	81.66	156.25	45.83	26.84	104.29
5	166.76	182.76	106.99	137.44	192.39	179.66	254.25	143.84	124.84	202.29
6	97.20	113.20	23.30	7.67	62.10	110.16	155.55	74.27	55.28	72.00
7	70.83	92.83	43.67	12.70	82.47	89.73	135.18	53.90	34.91	92.37
8	68.99	84.99	51.51	20.54	90.31	81.89	127.34	46.06	27.07	100.21
9	59.68	75.68	43.07	30.05	99.82	72.38	122.17	36.55	17.56	109.72
10	47.08	63.08	30.67	42.45	112.22	59.98	134.57	24.15	5.16	104.51
11	137.81	153.81	120.76	136.58	208.16	74.10	228.68	106.34	99.27	194.60
12	37.61	53.61	61.16	72.54	142.71	66.51	165.06	6.34	35.65	135.00
13	143.27	159.27	166.82	178.60	248.37	172.17	270.72	112.67	141.31	240.66
14	35.10	51.10	42.65	54.47	124.20	48.00	146.55	12.17	17.14	116.49
15	76.41	92.41	60.00	71.78	141.55	89.31	120.00	53.48	24.17	133.84
16	164.57	180.57	148.16	159.34	229.71	177.47	62.10	141.64	112.33	222.00
17	70.90	86.90	54.49	66.27	136.04	83.80	154.49	47.97	18.66	128.33
18	142.00	126.00	147.83	159.81	229.38	177.14	251.73	141.31	112.00	221.67
19	27.10	43.10	50.65	62.43	132.20	56.00	154.55	4.17	25.14	124.49
20	287.10	303.10	310.65	322.43	392.20	316.00	414.55	264.17	285.14	384.49
21	0.00	16.00	77.75	89.53	159.30	83.10	181.65	31.27	52.24	151.59
22	16.00	0.00	93.75	105.53	175.30	99.10	197.65	47.27	68.24	167.59
23	77.75	93.75	0.00	30.97	85.40	90.65	165.24	54.82	35.83	95.30
24	84.53	105.53	30.97	0.00	64.77	102.43	147.88	47.61	47.61	79.67
25	159.30	175.30	85.40	69.77	102.43	172.20	217.65	136.37	117.38	134.10
26	83.10	99.10	90.65	102.43	172.20	0.00	194.55	60.17	65.14	164.49
27	181.65	197.65	165.24	147.88	217.65	194.55	0.00	158.72	29.31	128.66
28	31.27	47.27	54.82	66.60	136.37	60.17	158.72	0.00	109.67	0.00
29	52.24	68.24	35.83	47.61	117.38	65.14	139.73	29.31	0.00	109.67
30	151.59	167.59	95.30	74.67	134.10	164.49	227.55	128.66	109.67	80.00
31	114.14	130.14	54.00	84.97	139.40	127.09	201.68	91.26	72.27	80.00
32	84.04	90.04	13.66	44.83	99.06	76.34	151.58	41.16	22.17	108.96
33	88.35	104.35	10.60	20.37	74.80	101.25	168.25	65.42	46.43	84.70
34	84.57	80.57	48.16	59.34	124.71	77.47	148.16	12.33	12.33	122.00
35	44.04	65.04	28.66	44.46	114.06	61.94	136.58	7.17	7.17	102.50
36	75.16	91.16	45.34	44.37	84.14	88.06	133.51	52.23	33.24	94.04
37	58.41	74.41	42.00	53.78	123.55	71.31	142.00	35.48	6.17	115.84
38	81.65	77.65	45.24	27.88	97.65	74.55	120.00	38.72	19.73	107.55
39	56.41	72.41	40.00	51.78	121.55	69.31	140.00	33.48	4.17	113.84
40	51.59	67.59	26.16	46.96	111.56	64.49	139.08	28.66	9.67	100.00
41	42.08	54.08	35.67	47.45	117.22	54.98	139.57	10.15	10.15	109.51

Figure 4. Typical Output Matrix

never used on any optimum route are also determined. The functional procedure is outlined in Figure 5.

Definitions

N The number of nodes of the network (N ≤ 100).

t_{ik} The input matrix of times between adjacent nodes. (FORTRAN symbol is T1.)

T_{ik} The input matrix of minimum times between all nodes. (FORTRAN symbol is T2.)

j_{ik}^* The matrix of calculated immediate predecessor nodes of the minimum time routes.

Output

Figure 6 gives a portion of a typical printout from this subroutine.

SUBROUTINE TCHEV DESCRIPTION

Given the matrix of minimum times (costs) between all nodes of a region of N nodes and a set of reaction times (or allowable costs), to test the matrix, $\{\hat{t}\}$ is determined which indicates the possibility or impossibility of reading each node from all other nodes (and vice-versa) within the given reaction times. A minimum supply node solution is determined for each reaction time and for each specified configuration of allowable supply and demand

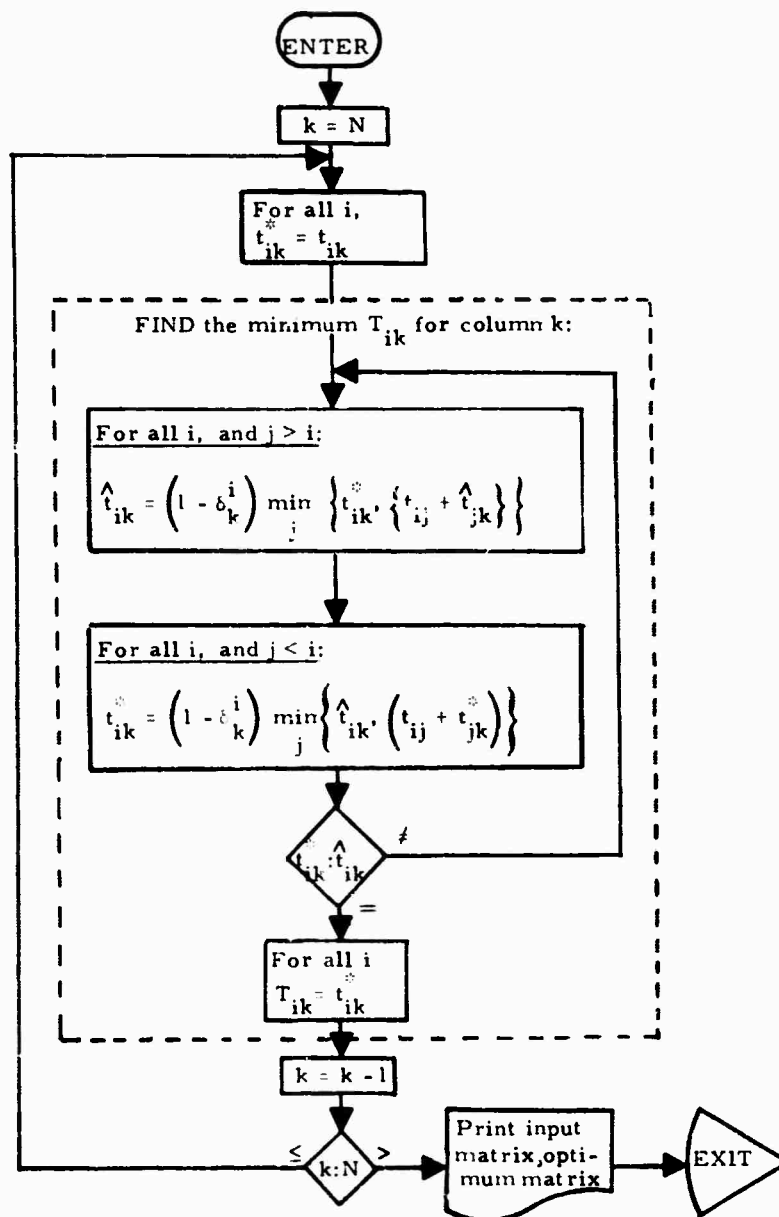

Figure 5. Functional Diagram for Subroutine DYNAMIC

PP JP WET 036AM007-24MINDEM102030312330303602502407080910

(1,JOOK) GIVES J AS AN IMMEDIATE PREDECESSOR NUDE TO NUDE I ON THE MINIMUM TIME ROUTE(S) FROM NUDE K

K = 37	20 40037	30 330037	40 320037	50 40037	60 240037	70 360037	80 380037	90 100037	100 290037
110 350037	120 280037	130 280037	140 410037	150 390037	160 340037	170 340037	180 370037	190 140037	200 190037
210 190037	220 210037	230 40037	240 70037	250 60037	260 140037	270 150037	280 190037	290 390037	300 400037
310 320037	320 400037	330 230037	340 370037	350 100037	360 80037	380 90037	390 370037	400 350037	410 100037

K = 38	20 40038	30 330038	40 320038	50 40038	60 240038	70 360038	80 380038	90 100038	100 290038
110 350038	120 280038	130 280038	140 410038	150 390038	160 340038	170 340038	180 290038	190 140038	200 190038
210 190038	220 210038	230 40038	240 70038	250 60038	260 140038	270 380038	280 190038	290 100038	300 60038
310 320038	320 400038	330 60038	340 370038	350 100038	360 80038	370 390038	390 290038	400 350038	410 100038

K = 39	20 40039	30 330039	40 320039	50 40039	60 240039	70 360039	80 380039	90 100039	100 290039
110 350039	120 280039	130 280039	140 410039	150 390039	160 340039	170 340039	180 370039	190 140039	200 190039
210 190039	220 210039	230 40039	240 70039	250 60039	260 140039	270 150039	280 190039	290 390039	300 400039
310 320039	320 400039	330 230039	340 370039	350 100039	360 80039	370 390039	380 90039	400 350039	410 100039

K = 40	20 40040	30 330040	40 320040	50 40040	60 330040	70 360040	80 380040	90 100040	100 350040
110 350040	120 280040	130 280040	140 410040	150 390040	160 340040	170 340040	180 290040	190 140040	200 190040
210 190040	220 210040	230 40040	240 70040	250 60040	260 140040	270 380040	280 190040	290 100040	300 400040
310 320040	320 400040	330 230040	340 370040	350 400040	360 80040	370 390040	380 90040	390 290040	400 350040

K = 41	20 40041	30 330041	40 320041	50 40041	60 240041	70 360041	80 380041	90 100041	100 410041
110 350041	120 280041	130 280041	140 410041	150 390041	160 340041	170 340041	180 290041	190 140041	200 190041
210 190041	220 210041	230 40041	240 70041	250 60041	260 140041	270 380041	280 190041	290 100041	300 400041
310 320041	320 400041	330 230041	340 370041	350 100041	360 80041	370 390041	380 90041	390 290041	400 350041

NETWORK LINKS NEVER USED

(3, 2) (9, 7) (15, 9) (22, 17) (25, 7) (25, 24) (32, 13) (35, 24) (36, 1) (41, 26)

Figure 6. Typical JSTAR Printout

nodes. The functional flow diagram is provided in Figure 7.

Definitions

- (\hat{c}_{ik}) The Boolean matrix of reachability.
- N The number of nodes in the region ($N \leq 100$).
- A' The complement of Boolean vector A ($A'A \equiv 0$)

MMAX The number of reaction times in t_R ($MMAX \leq 20$).

$[T_{ik}]$ The input $N \times N$ matrix of minimum times between all nodes. (FORTRAN symbol is T2.)

$[t_{Rm}]$ The input matrix of reaction times. (FORTRAN symbol is TR.)

Outputs

Figures 8, 9, and 10 are portions of typical outputs from this subroutine.

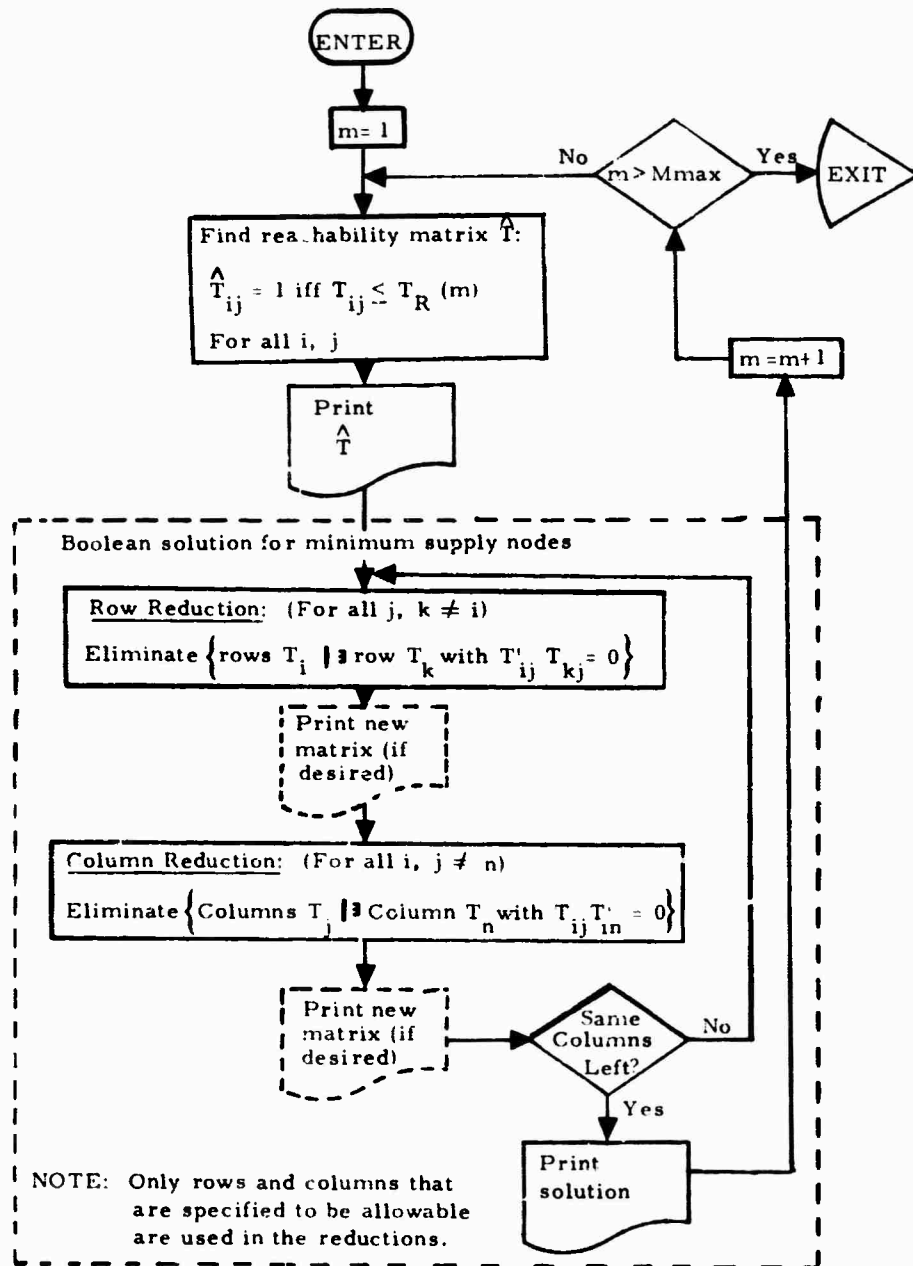

Figure 7. Functional Diagram for Subroutine TCHEV

PP JP WE(830AW.6,7-24MIN. DEM1.2.3.4.31.23.30.3.6.25.24.7.8.9.10

TCHEV(1,K), K TO 1, FOR TR= 75.00

K	1	2	3	4	5
1	1234567890	1234567890	1234567890	1234567890	1234567890

THE DEMAND NODES ARE

XX 1111011111 0000000000 0011100001 1000000000 0

THE SUPPLY NODES ARE

XX 1111111111 1111111111 1111111111 1111111111 1

1	1101011111	0101101010	0011000110	1111111111	1
2	1101011111	0101101010	0011000110	1111111111	1
3	0010010000	0000000000	0010100000	0010000000	0
4	1101011111	0101101010	1011000110	1111111111	1
5	0000100000	0000000000	0000000000	0000000000	0
6	1111011111	0001001010	0011100111	0111111111	1
7	1101011111	0101101010	0011000110	0111111111	1
8	1101011111	0101101010	1011000110	0111111111	1
9	1101011111	0101101010	1011010110	0111111111	1
10	1101011111	0101101010	1111010110	1111111111	1

11	0000000000	1000000000	0000010000	0000000000	0
12	1101001111	0101101010	1111010110	0111111111	1
13	0000000000	0010000000	0000000000	0000000000	0
14	1101011111	0101101010	1111010110	0111111111	1
15	1101001111	0101101010	0011000110	0111111111	1
16	0000000000	0000010000	0000010000	0000000000	0
17	1101011111	0101101010	1011000110	0111111111	1
18	0000000000	0000000100	0000000000	0000000000	0
19	1101011111	0101101010	1111010110	0111111111	1
20	0000000000	0000000001	0000000000	0000000000	0

21	0001000111	0101001010	1100000110	0101101111	1
22	0000000001	0101000010	1100000110	0000101011	1
23	1111011111	0101101010	0011000110	1111111111	1
24	1101011111	0101101010	0011100110	0111111111	1
25	0010010000	0000000000	0001100000	0010000000	0
26	0000000011	1101000010	0000010110	0000101111	1
27	0000000000	0000010000	0000001000	0000000000	0
28	1101011111	0101101010	1111010110	0111111111	1
29	1101011111	0101101010	1111010110	1111111111	1
30	0000010000	0000000000	0000000001	0000000000	0

31	1101000001	0000000000	0010000010	1110100001	1
32	1101011111	0101101010	1011000110	1111111111	1
33	1111011111	0101101010	0011100110	1111111111	1
34	1101011111	0101101010	1011000110	0111111111	1
35	1101011111	0101101010	1111010110	1111111111	1
36	1101011111	0101101010	0011000110	0111111111	1
37	1101011111	0101101010	1111010110	0111111111	1
38	1101011111	0101101010	1011010110	0111111111	1
39	1101011111	0101101010	1111010110	0111111111	1
40	1101011111	0101101010	1111010110	1111111111	1

41 1101011111 0101101010 1111010110 1111111111 1

Figure 8. Typical \hat{T} Printout

```

PP JP WEI 830AW,0,7-24MIN,DEM1,2,3,4,31,23,30,3,6,25,24,7,8,9,10

      BOOLEAN ROW AND COLUMN REDUCTIONS

      (I*J) DENOTES ROW I ELIMINATED BY ROW J
      (I**J) DENOTES COLUMN I ELIMINATED BY COLUMN J

( 2* 1)   ( 4* 1)   (10* 1)   (23* 1)   ( 6* 3)
( 1* 7)   ( 8* 7)   ( 9* 7)   (24* 7)   (
( 1** 2)  ( 2** 4)  ( 3** 6)  ( 4**10)  ( 5** 6)
( 7** 6)  ( 8** 6)  ( 9** 6)  (10**23) (11** 6)
(12** 6)  (13** 6)  (14** 6)  (15** 6) (16** 6)
(17** 6)  (18** 6)  (19** 6)  (20** 6) (21** 6)
(22** 6)  (23** 31) (24** 6)  (25** 6) (26** 6)
(27** 6)  (28** 6)  (29** 32) (30** 6) (31** 32)
(32** 3)  (34** 6)  (35** 33) (36** 6) (37** 6)
(38** 6)  (39** 6)  (40** 33) (41** 33) (
( 7* 3)   (23* 3)   ( 3* 30)   (

      NO FURTHER REDUCTION IS POSSIBLE

```

Figure 9. Typical Boolean Reduction Printouts.

```

PP JP WEI 830AW,0,7-24MIN,DEM1,2,3,4,31,23,30,3,6,25,24,7,8,9,10

      (LHEV(I,K), K TO 1, FOR TR= 75.00

      N
      1 2 3 4 5
      I 1234567890 1234567890 1234567890 1234567890 1234567890

      THIS IS THE FINAL REDUCED MATRIX

      THE DEMAND NODES ARE
      XX 1111011111 0000000000 0011100001 1000000000 0

      THE SUPPLY NODES ARE
      XX 1111111111 1111111111 1111111111 1111111111 1
      J0 0000010000 0000000000 0000000000 0000000000 0
      J1 0000000000 0000000000 0000000000 0010000000 0

```

(Principal solutions are nodes 6 and 33.)

Figure 10. Typical Final Printout

APPENDIX F

NETSIM PROGRAM CAPABILITY

INTRODUCTION

The NETSIM program performance was initially tested on 5- and 7-node hypothetical transportation networks for which computational checks on the computer solutions were readily obtained. The hypothetical transportation network was then changed to a 20-node network, and the application of the NETSIM program to this network is discussed in this appendix.

Objective

The test networks were chosen so that options in the program could be exercised which would not necessarily be utilized in a specific more realistic transportation network and to serve as development analysis examples. Such examples would readily indicate program capabilities and avenues of improvement in the simulation model, which could be effectively utilized in the more sophisticated overall SIMDATS program. Several program

modifications were introduced in the NETSIM program as a result (and are included in the description of the NETSIM program in Appendix E) and were utilized in the analysis of the 41-node region discussed in the report. The inclusion in the program of the listing of routes never used on any optimum path, and the generation of minimum supply node solutions are examples of the program modifications introduced as a result of the analysis of the 20-node hypothetical transportation network.

NETWORK DESCRIPTION

The 20-node hypothetical network was analyzed in two configurations, symmetric and unsymmetric. Figure 1 illustrates the unsymmetrical network and Figure 2 presents the symmetrical version. Link travel times are indicated by the

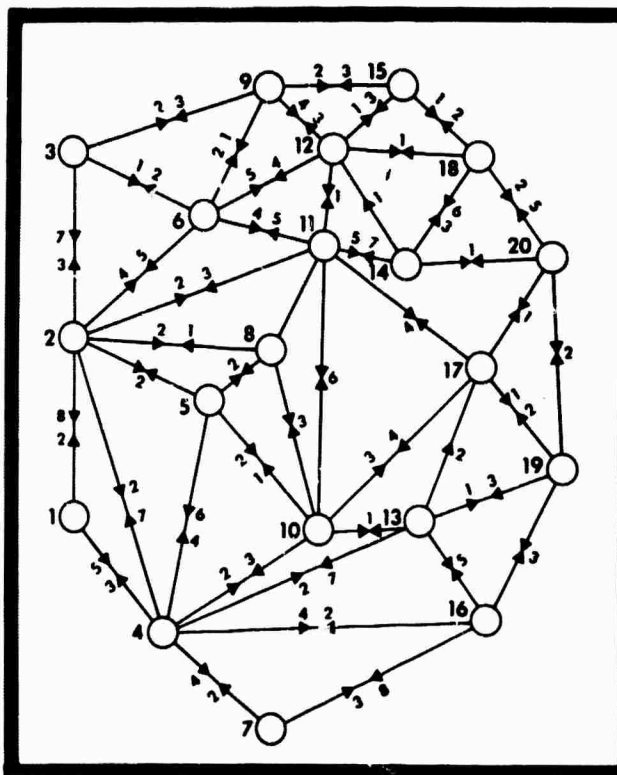

Figure 1. Unsymmetrical 20-Node Network With Link Times

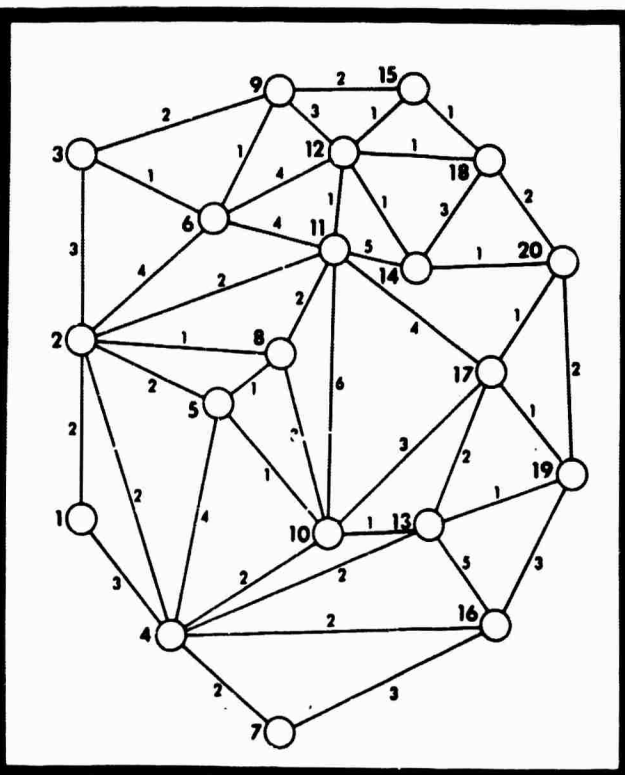

Figure 2. Symmetrical 20-Node Network With Link Times

number next to the link. It will be noted from Figure 1 that there are only two network links, 12-17 and 14-12, which permit only one-way travel; the remainder permit two-way travel, with most link times being dependent upon direction. In the symmetric case, link travel time is independent of direction, and was derived from the unsymmetric case by choosing the minimum link travel time for each link, which simulated selected link improvements. The link and link travel times were chosen arbitrarily. The use of travel time as a link descriptor is equivalent to the assumption that a segment analysis (as in the general SIMDATS program) has been performed for some vehicle.

The link travel times are more conveniently (for some purposes) described by the basic matrix (t), as shown in Figure 3, which describes the symmetric matrix. Transit times across each node are set to zero as shown by the t_{ij} entries to simplify the pencil and paper computations. Actual computer printouts are illustrated in Appendix E.

OPTIMUM TRANSIT TIMES

The minimum transit time matrix for the symmetric network is shown in Figure 4, which indicates that the maximum optimum time of travel within the network is 9 units. This matrix is the basic matrix determined in the NETSIM program and is used in the derivation of all other program outputs. This matrix, in the NETSIM program, is used in the determination of optimum routes, reaction time reachabilities and minimum supply node solutions. With the addition of simple subroutines, it could be used to determine the link(s) which should be improved so that no transit time within a particular subregion of the network would be greater than a desired reaction time. Such regions could be disjointed subregions, overlapping

subregions, or the total region, and a different desired reaction time could be specified for each subregion. All of these considerations apply, of course, to actual costs or to a generalized cost function as well as to time alone.

OPTIMUM ROUTES

The optimum routes followed in the symmetrical network are presented in condensed form in Figure 5. Figure 5 is a matrix, Jⁿ(l, K), presenting the number of the node(s) immediately preceding node l on the optimum route from node K. (See Appendix B for the mathematical description and Appendix E for a sample computer print-out.) The optimum route from any node is easily determined by successive evaluations of matrix entries. Consider, for example, the determination of the optimum route from node 15 to node 16. Figure 5 indicates that the immediate predecessor nodes to node 16 are 4 and 19. Now, 15-4 passes through 2, 15-2 passes through 11, 15-11 passes through 12 and 15-12 is used directly; 15-19 passes through 17 or 20, 15-17 passes through 20, 15-20 passes through 14 or 18, 15-14 passes through 12, and 15-18 is used directly. Thus, the optimum paths are:

- 15-12-11-2-4-16
- 15-12-14-20-19-16
- 15-18-20-17-19-16
- 15-18-20-19-16

The number of possible paths giving the same minimum time is caused, in this case, partly because integers were used for link times. However, it is typical of more general situations in which one asks not for routes giving the minimum time, but for routes along which the time is within

	Starting Node																			
	1	2	3	4	5	6	7	8	9	10	11	12	13	14	15	16	17	18	19	20
1	0	2	3																	
2		0	3	2	2	4		1			2									
3			0			1				2										
4				0	4		2				2			2						
5					0			1		1										
6						0			1		4	4								
7							0											3		
8								0		3	2									
9									0			3			2					
10										0	6		1						3	
11											0	1		5					4	
12												0		1	1				1	
13													0		5	2				1
14														0					3	1
15															0				1	
16																0			3	
17																	0		1	1
18																		0	2	
19																			0	2
20																				0

(The matrix is symmetric.)

Figure 3. Incremental Matrix (t)

	Starting Node																			
	1	2	3	4	5	6	7	8	9	10	11	12	13	14	15	16	17	18	19	20
1	0	2	5	3	4	6	5	3	7	5	4	5	5	6	6	5	7	6	6	7
2		0	3	2	2	4	4	1	5	3	2	3	4	4	4	4	6	4	5	5
3			0	5	5	1	7	4	2	6	5	5	7	6	4	7	8	5	8	7
4				0	3	6	2	3	7	2	4	5	2	6	6	2	4	6	3	5
5					0	6	5	1	7	1	3	4	2	5	5	5	4	5	3	5
6						0	8	5	1	7	4	4	8	5	3	8	7	4	8	6
7							0	5	9	4	6	7	4	8	8	3	6	8	5	7
8								0	6	2	2	3	3	4	4	5	5	4	4	5
9									0	3	4	3	8	4	2	9	6	3	7	5
10										0	4	5	1	5	6	4	3	6	2	4
11											0	1	5	2	2	6	4	2	5	3
12												0	5	1	1	7	3	1	4	2
13													0	4	6	4	2	5	1	3
14														0	2	6	2	2	3	1
15															0	8	4	1	5	3
16																0	4	7	3	5
17																	0	3	1	1
18																		0	4	2
19																			0	2
20																				0

(The matrix is symmetric.)

Figure 4. Optimum Matrix (T)

I	Starting Node																			
	1	2	3	4	5	6	7	8	9	10	11	12	13	14	15	16	17	18	19	20
1	-	2	2	4	2	2	4	2	2	2,4	2	2	4	2	2	4	4	2	4	2
2	1	-	3	4	5,8	3,6	4	8	3,6	5,8	11	11	4,5,8	11	11	4	4,5 8,11	11	4,5,8	11
3	2	2	-	2	2	6	2	2	6,9	2	2,6	6,9	2	6,9	2	6,9	2	6,9	2	6,9
4	1	2	2	-	10	2	7	2	2	10	2	2	13	2,13	2	16	13	2	13	13
5	2,8	2,8	2,8	10	-	2,8	10	8	2,8	10	8	8	10	8	8	10	10	8	10	10
6	2,3	2,3	3	2,3	2,3	-	2,3	2,3	9	2,3	11	9,12	2,3	9,12	9	2,3	9,12	9	9,12	9,12
7	4	4	4	4	4	4	-	4	4	4	4	4	4	4	4	16	4	4	4	4
8	2	2	2	2	5	2	2	-	2,11	5	11	11	5	11	11	2	5	11	5	11
9	3,6	3,6	3,6	3,6	3,6	3,6	3,6	3,6	3,12	3,12	12,15	12,15	12,15	12,15	15	3,6	12,15	15	12,15	12,15
10	4,5	5	5	4	5	5	4	5	5	-	5	5	13	13,17	5	4	13,17	5,13 17	13	13,17
11	2	2	2,6	2	8	6	2	8	12	8	-	12	8	12	12	2	12,17	12	12,17	12
12	11	11	6,9 15	11	11	6,9 15	11	11	9,15	11	11	-	14	14	15	11,14	14	18	14	14
13	4	4,10	4,10	4	10	4,10	4	10	17,19	10	10	17,19	-	17,19	17,19	4,19	17,19	17,19	19	17,19
14	12	12	12	12,20	12	12	12,20	12	12	20	12	12	20	-	12	20	20	12	20	20
15	12	12	9	12	12	9	12	12	9	12	12	12	12,18	12	-	12,18	12,18	18	12,18	12,18
16	4	4	4	4	4	4	7	4	4	4	4	4,19	4,19	19	4,19	-	19	19	19	19
17	13,19 13,19 20	10,11 13,19 20	20	13,19	10,13 19	20	13,19 19	10,13 19	20	10,13 19	11,20	20	13,19	20	20	19	-	20	19	20
18	12	12	15	12	12	15	12	12	15	12,20	12	12	20	12	15	20	20	-	20	20
19	13	13	13	13	13	17,20	13	13	17,20	13	17,20	17,20	13	17,20	17,20	16	17	17,20	-	17,20
20	14	14	14,18	17,19	17,19	14,18	17,19	14	14,18	17,19	14	14	17,19	14	14,18	17,19	17	18	17,19	-

Figure 5 . Matrix of Immediate Predecessor Nodes J*(I,K)

a fixed amount of the minimum time, or within some fraction of the minimum time. The NETSIM program requires only a minor addition to yield this capability.

Several different uses of this data might be made by the transportation system analyst. Figure 6 indicates the optimum routes from node 10 to all other nodes. Within each node symbol of Figure 6 is the time taken to get to that node from node 10 (taken from the optimum time matrix). In many cases, several possible paths are indicated. With the use of the general SIMDATS map subroutine, such plots could be made automatically.

Figure 7 indicates the optimum routes from each node into node 9, for both the symmetric and unsymmetric hypothetical networks. In this case, the numbers within each node represent the minimum time from that node to node 9. Again, this type of map could be printed automatically in the more comprehensive SIMDATS program.

The data represented by each such map can be utilized in total traffic pattern analysis (e.g., in social, political or economic analyses) or in more complex situations such as security applications involving interdiction, logistics, maintenance encirclement, etc. This capability would be part of the general SIMDATS program, although only minor modifications to the present NETSIM

computer program could provide useful capability in these areas.

The network links never used on any optimum path are presented in Figure 9 for both networks. Figure 8B indicates the directional non-use of several links, which would be valuable in the system analysis of a general situation, regarding, for example, the establishment of maintenance levels, road improvements, etc. Different results would be obtained for each cost function utilized, and could be compared to determine solutions providing maximum benefit.

The coverage from node 2 is shown in Figure 9, which indicates, in essence, the time marks along each route. Such a map indicates not only the coverage of nodes, but also the coverage along roads, and would be pertinent to security situations in which several different reaction or patrol strategies might be considered.

REACHABILITY

In some cases, it may be necessary to know only whether it is possible to reach, within a given reaction time (or cost), a particular node from some other node. Such data can be obtained simply by inspection of the optimum T matrix. For convenience however, the NETSIM program provides a

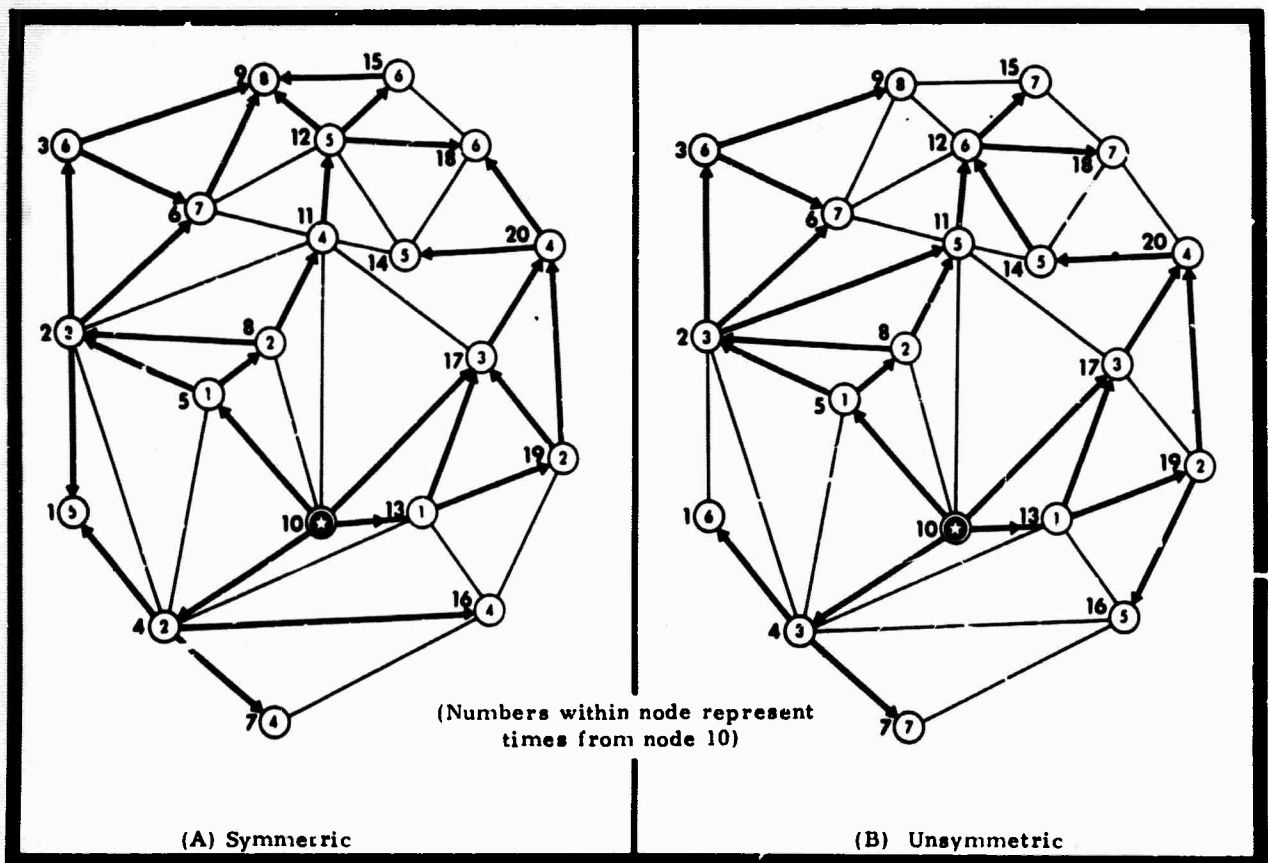

Figure 6. Optimum Routes From Node 10.

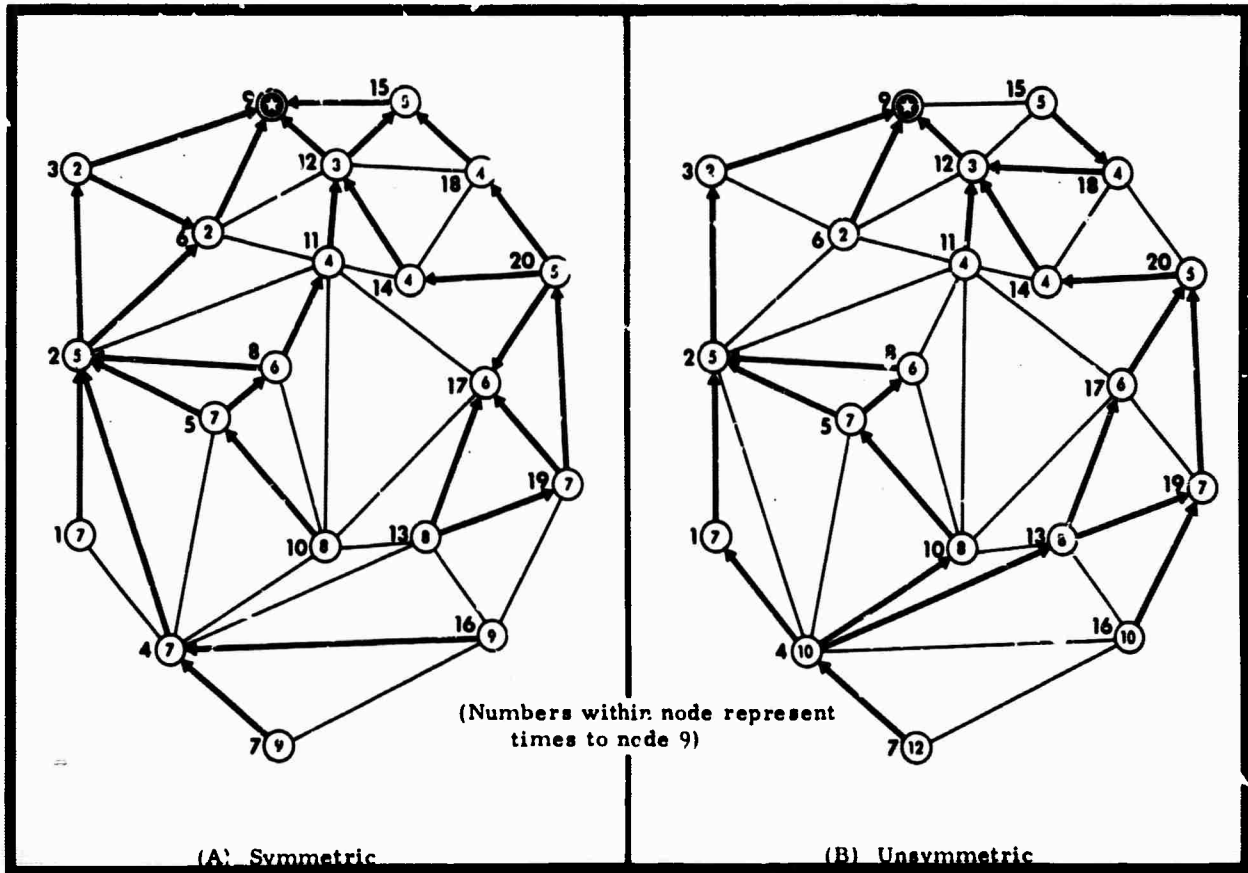

Figure 7. Optimum Routes Into Node 9.

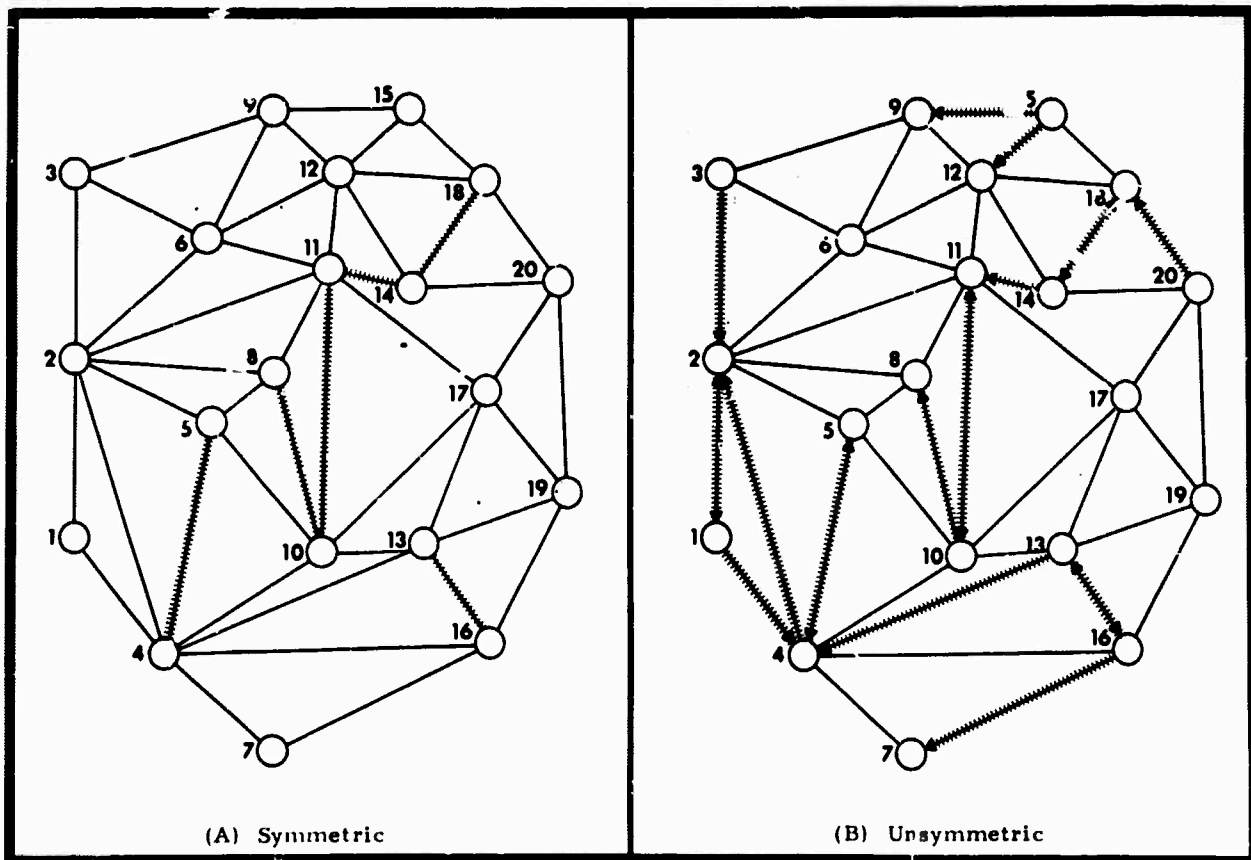

Figure 8. Links Never Used on Optimum Routes

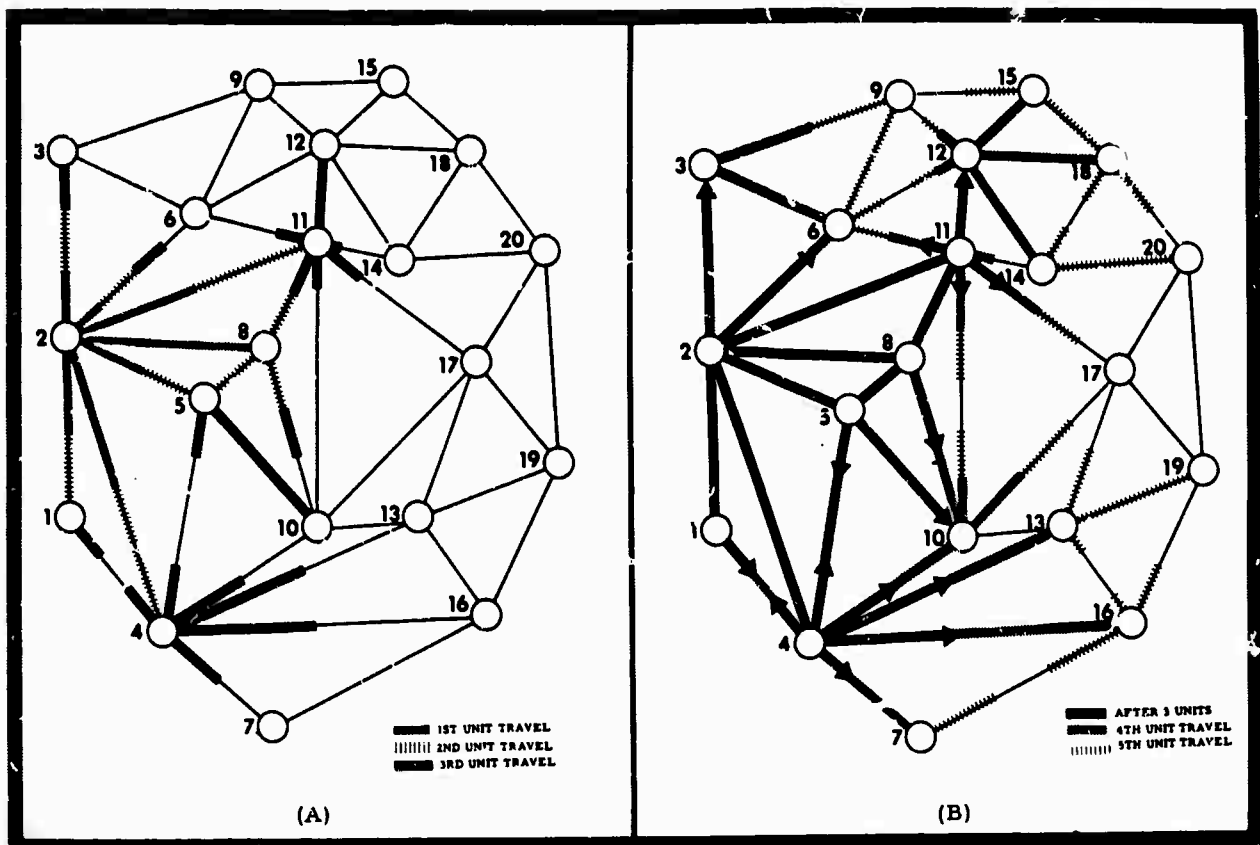

Figure 9. Travel From Node 2

condensed matrix, \hat{T} , printout, as shown in Figure 10, in which a "1" indicates that node I can be reached from node K within the specified reaction time. The 1 indicates that the assertion "node I can be reached from node K within reaction time T_R ", is true and 0 indicates that the assertion is false.

A listing of the allowable supply and demand nodes also appears in the printout of the \hat{T} matrices. (All nodes are allowable supply and demand nodes in Figure 10.) That information is used in the determination of minimum node solutions. In the present NETSIM program, uniform reaction times T_R have been specified for each node. This could easily be modified so that each demand node, or set of nodes, could have a different reaction time requirement.

MINIMUM SUPPLY NODE SOLUTIONS

In order to minimize installation and logistics costs, the number of supply nodes (e.g., police stations) should be minimized. The present NETSIM program provides a minimum station solution for each reaction time specified (or reduces the problem to one manageable by pencil and paper analysis, as discussed in Appendix D).

Table 1 lists the minimum number of supply nodes required for both the symmetric and unsymmetric hypothetical networks for seven different reaction times. It is assumed that only one node at a time must be supplied, that all nodes have a uniform demand, that all nodes are demand nodes, and that any node can be a supply node.

Table 1. Number of Minimum Node Solutions

T_R	Minimum Number of Supply Nodes	
	Symmetric Network	Unsymmetric Network
7	1	1
6	1	2
5	2	3
4	2	3
3	3	5
2	4	6
1	9	9

Symmetric Network

When all nodes are allowable supply and demand nodes, and uniform at each node, the 2-node solutions obtained for the symmetrical

```

BASIC 20x20 TEST CASE (SYM) 29 JAN 67
      ICHEV(I,K), K TO 1, FOR TR= 5.0
K      1      2      3
1 1234567890 1234567890 1234567890 123456789
      THE DEMAND NODES ARE
XX 1111111111 1111111111
      THE SUPPLY NODES ARE
XX 1111111111 1111111111
1 1111101101 1110010000
2 1111111111 1111110111
3 1111110110 1100100100
4 1111101101 1110011011
5 1111101101 1111111111
6 0110010110 1101100100
7 1101101101 0010010010
8 1111111101 1111111111
9 0110010010 1101100101
10 1101101101 1111011011
11 1111110111 1111101111
12 1111110111 1111101111
13 1101101101 1111011111
14 0100110111 1111101111
15 0110110110 1101101111
16 1101101101 0010011011
17 0001100101 1111111111
18 0110110110 1111101111
19 0101101101 1111111111
20 0101100111 1111111111

```

Figure 10. \hat{T} Printout

network with $T_R = 4$ are the configurations

$$\begin{bmatrix} 2 \\ 18 \end{bmatrix} \text{ or } \begin{bmatrix} 4 \\ 15 \end{bmatrix}$$

Each one of a pair of listed nodes must be a supply node. Figure 11 provides the computer printout for this case, showing the \hat{T} matrix, the Boolean row and column reductions (see Appendix D for the mathematical formulation), and the final solution listed above. Using the column eliminations, equivalence sets are defined by:

$$\{\hat{M}\} = \{K \mid \text{Column } K \text{ was eliminated by column } M, \text{ or } K = M\}$$

Thus, for $T_R = 4$, the equivalence sets are:

$$\begin{aligned} \{\hat{2}\} &= \{1, 2, 7\} \\ \{\hat{4}\} &= \{4, 5, 10, 13, 16\} \\ \{\hat{8}\} &= \{8\} \\ \{\hat{15}\} &= \{3, 6, 9, 11, 15\} \\ \{\hat{18}\} &= \{12, 14, 17, 18, 19, 20\} \end{aligned}$$

Candidate solutions are, therefore, of the form $\begin{bmatrix} I \\ J \end{bmatrix}$ where $I \in \hat{2}$ and $J \in \hat{18}$ or $I \in \hat{4}$ and $J \in \hat{15}$, to satisfy the format of the already determined solutions. Not all of these candidates for solutions actually yield solutions; the total solution is (where + is the symbol for "or")

$$\begin{bmatrix} 2 \\ 18 \end{bmatrix} \begin{bmatrix} 12 + 14 + 18 \end{bmatrix} + \begin{bmatrix} 4 \\ 15 \end{bmatrix}$$

Figure 12 presents a graphical display, in clock diagram form, of the total solution set for $T_R = 4$. A solid line between a pair of nodes indicates that that pair of nodes is a solution. Figures 13 and 14 indicate, in map form, two of the solutions, and the network coverage from each solution node.

This solution is the only one found, thus far, in which two disjoint sets of pair classes form solutions. (The equivalence sets can always be made disjoint. If $\begin{bmatrix} A \\ B \end{bmatrix}$ forms the principal solution, and if $y \in A$ and $y \in B$, then y is not part of the $\begin{bmatrix} A \\ B \end{bmatrix}$ solution set.)

Figure 15 provides the computer printout for $T_R = 3$. Here, the principal solution obtained by the computer is

$$\begin{bmatrix} 4 \\ 9 \\ 20 \end{bmatrix}$$

The equivalence classes are

$$\begin{aligned} \{\hat{4}\} &= \{4, 7, 16\} \\ \{\hat{9}\} &= \{1, 2, 3, 5, 6, 8, 9, 11, 15\} \\ \{\hat{20}\} &= \{10, 12, 13, 14, 17, 18, 19, 20\} \end{aligned}$$

and of these candidates, the solutions are

$$\begin{bmatrix} 4 \\ 3 + 6 + 9 \end{bmatrix} \begin{bmatrix} 12 + 14 + 18 + 20 \end{bmatrix}$$

Figure 16 presents this in clock chart form, and the network coverage of one of the solutions is indicated in Figure 17.

Figure 18 presents the solutions in clock diagram form and Figure 19 gives the network coverage provided by a typical solution for $T_R = 1$. Figure 20 gives the unique solution for $T_R = 2$. For $T_R = 5$, a great many solutions exist as shown by the clock diagram of Figure 21. In this case there exists a different phenomenon. Every three nodes used as a solution according to the clock diagram of Figure 22 have the property that at least two of them can supply every node. Using a 3-node solution (see Appendix D), if the restriction on minimum nodes were relaxed (retaining the one-at-a-time demand), the total resource required would be only 75% of that required by a 2-node solution. (If the demand is one unit, this can be supplied by at least

BASIC 20A20 TEST CASE (SYM) 29 JAN 68

(CHEV(I,K), K TO 1, FOR I= 4.00

K 1 2 3 4
 1234567890 1234567890 1234567890 1234567890 1234567890

THE DEMAND NODES ARE

1 1111111111 1111111111

THE SUPPLY NODES ARE

2 1111111111 1111111111

3 0110010110 0000100000

4 1101101101 1010011010

5 1101100101 1110001010

6 0110010010 1100100100

7 0101001001 0010010000

8 1111100101 1111100110

9 0010010010 1101100100

10 0101101101 1010011011

11 1101110111 1101101101

12 0100110110 1101101111

13 0101101101 0011011011

14 0100000110 1111101111

15 0110010110 1101101101

16 0101001001 0010011010

17 0001100001 1111111111

18 0100010110 1101101111

19 0001100101 0111011111

20 0000000001 1111101111

EQUIVALENCE SETS

{2, 1, 7}

{4, 5, 10, 13, 16}

{8}

{15, 3, 6, 9, 11}

{18, 12, 14, 17, 19, 20}

SOLUTIONS

$$[2][12 + 14 + 18] + [4][15]$$

BASIC 20A20 TEST CASE (SYM) 29 JAN 68

DOUBLEAN NUM AND COLUMN REDUCTIONS

((*J) DEMOTES ROW I ELIMINATED BY ROW J

((**J) DEMOTES COLUMN I ELIMINATED BY COLUMN J

(2* 1) (4* 1) (5* 1) (8* 1) (11* 1)

(15* 3) (10* 7) (13* 7) (16* 7) (12* 18)

(17* 20) (3* 6) (5* 4) (6* 9) (7* 2)

(4* 15) (10* 13) (12* 18) (14* 18) (1* 2)

(17* 18) (19* 18) (20* 18) (1* 4)

(14* 3) (18* 3) (6* 9) (20* 9) (1

(13* 4) (1* 7) (11* 15) (

(11* 15) (

NO FURTHER REDUCTION IS POSSIBLE

BASIC 20A20 TEST CASE (SYM) 29 JAN 68

(CHEV(I,K), K TO 1, FOR I= 4.00

K 1 2 3 4 5
 1234567890 1234567890 1234567890 1234567890 1234567890

THIS IS THE FINAL REDUCED MATRIX

THE DEMAND NODES ARE

1 1111111111 1111111111

THE SUPPLY NODES ARE

3 0100000100 0000100000

7 0101000000 0000000000

9 0000000000 0000100100

19 0001000100 0000000100

Figure 11. Sample Results for TR = 4

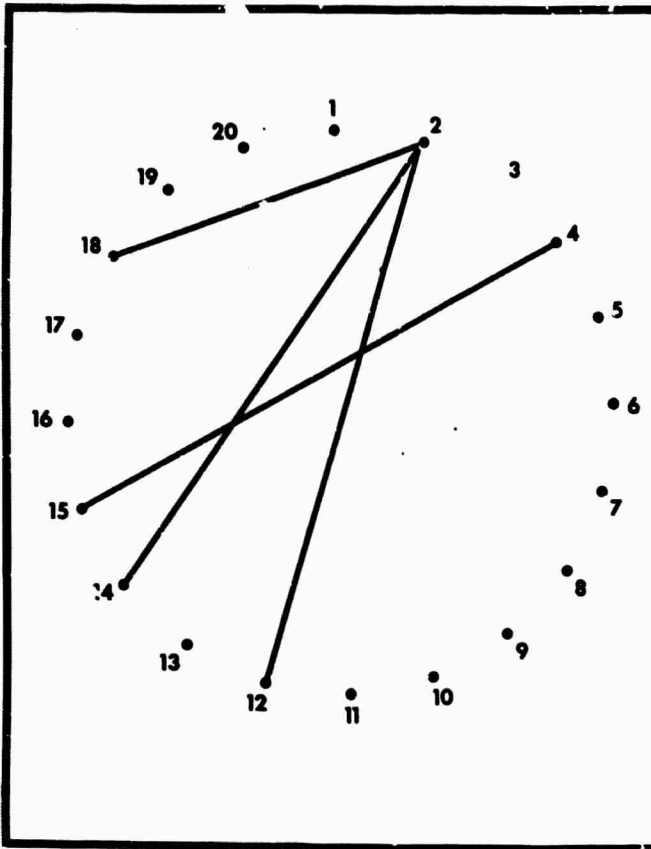

Figure 12. Solutions for $T_R = 4$.

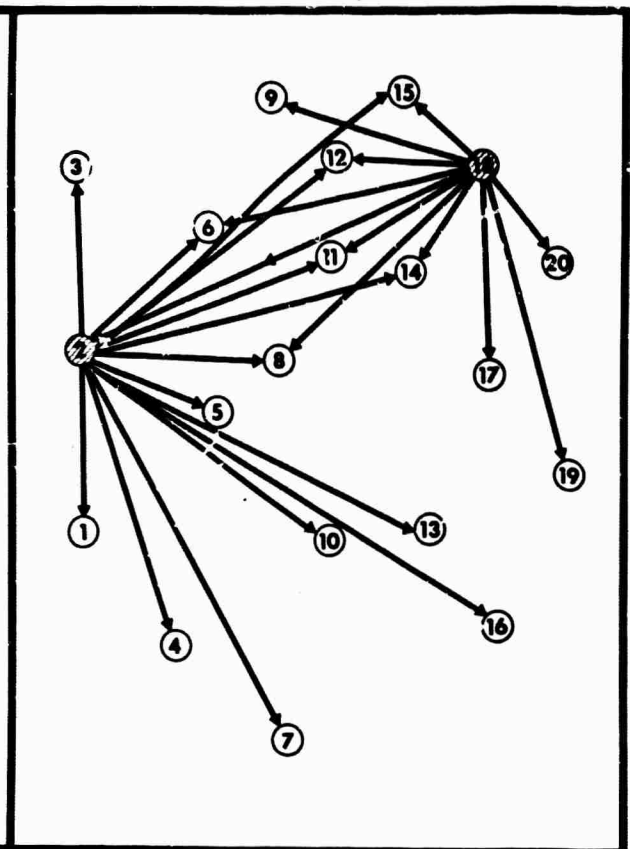

Figure 13. Network Coverage by the [2] [18] Solutions ($T_R = 4$)

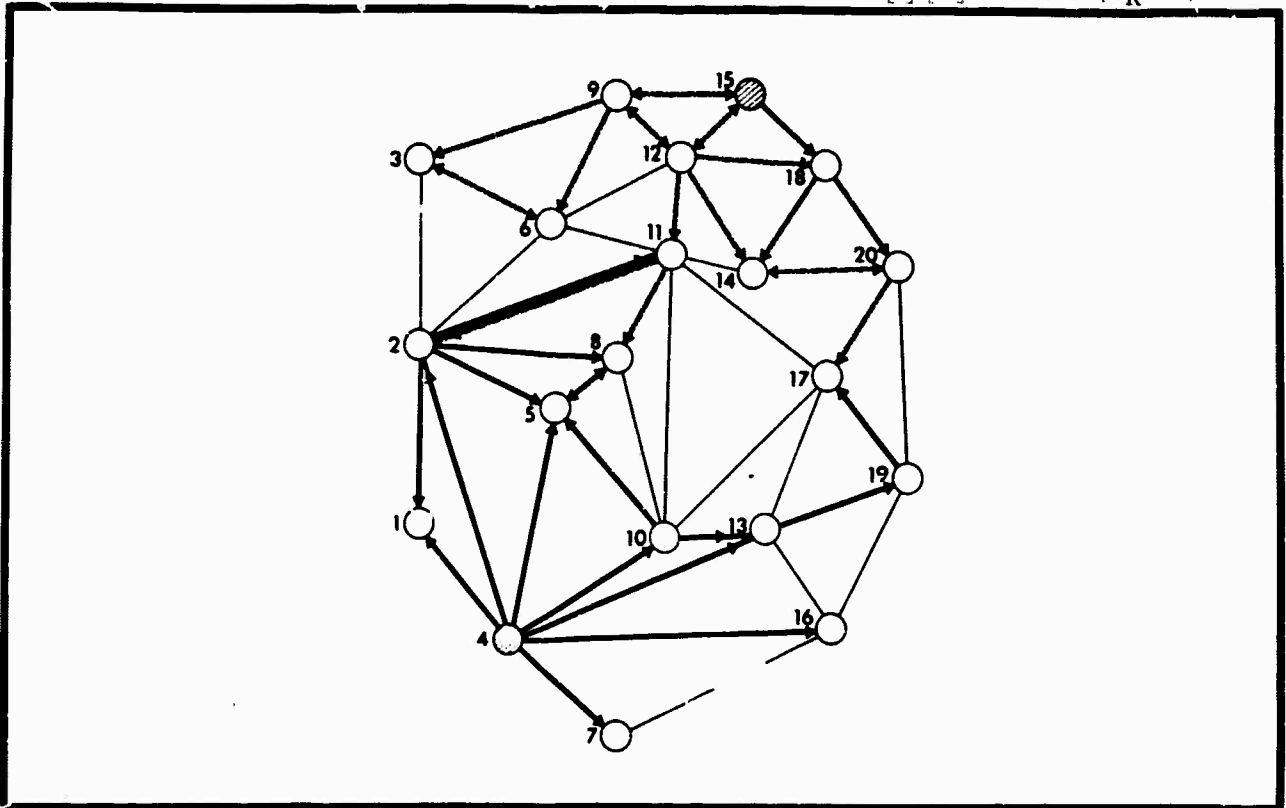

Figure 14. Network Coverage by the [4] [15] Solution ($T_R = 4$)

BASIC 20x20 TEST CASE (SYM) 29 JAN 68

ICHEV(I,N), K IO I, FOR IM= 3.00
 K 1234567890 1234567890 1234567890 1234567890 1234567890
 I 1

THE DEMAND NODES ARE

AA 1111111111 1111111111

THE SUPPLY NODES ARE

AA 1111111111 1111111111

1 110100100 000000000
 2 111100101 110000000
 3 011001010 000000000
 4 110110101 001001010
 5 010110010 101000010
 6 001001010 000100000
 7 000100100 000001000
 8 110110010 111000000
 9 001001010 010010010
 10 010110010 001000100
 11 010010010 110110010
 12 010000010 110110101
 13 000110010 001000101
 14 000000000 110110111
 15 000001000 110110010
 16 000100100 000001000
 17 000000000 011100111
 18 000000010 110110101
 19 000110001 001101101
 20 000000000 111110111

EQUIVALENCE SETS

{4, 7, 16}
 {9, 1, 2, 3, 5, 6, 8, 11, 15}
 {20, 10, 12, 13, 14, 17, 18, 19}

SOLUTIONS

[4]{3 + 6 + 9}[12 + 14 + 18 + 20]

BASIC 20x20 TEST CASE (SYM) 29 JAN 68

MOULERS MUM AND COLUMN REDUCTIONS

(10J) DEMOTES MUM I ELIMINATED BY ROW J

(100J) DEMOTES COLUMN I ELIMINATED BY COLUMN J

(20 1) (40 1) (80 1) (90 6) (100 7)
 (20* 14) (120 18) ((600 9) (700 4) (1000 13)
 (100 2) (300 6) (1400 20) (1600 4) (1800 20)
 (1200 14) (1300 19) (1500 6) (1800 6) (1900 7)
 (50 1) (100 1) (140 17) ((1700 19) (1900 20)
 (130 7) (190 7) (140 17) ((1700 19) (1900 20)
 (500 2) (800 2) (1100 2) (1700 19) (1900 20)
 (110 17) (1500 9) ((1700 19) (1900 20)
 (200 9) (1500 9) ((1700 19) (1900 20)
 (60 3) ((1700 19) (1900 20)

NO FURTHER REDUCTION IS POSSIBLE

BASIC 20x20 TEST CASE (SYM) 29 JAN 68

ICHEV(I,N), K IO I, FOR IM= 3.00

K 1234567890 1234567890 1234567890 1234567890 1234567890
 I 1

THIS IS THE FINAL REDUCED MATRIX

THE DEMAND NODES ARE

AA 1111111111 1111111111

THE SUPPLY NODES ARE

AA 1111111111 1111111111

3 000000010 000000000
 7 000000000 000000000
 17 000000000 000000000

Figure 15. Sample Results for R = 3

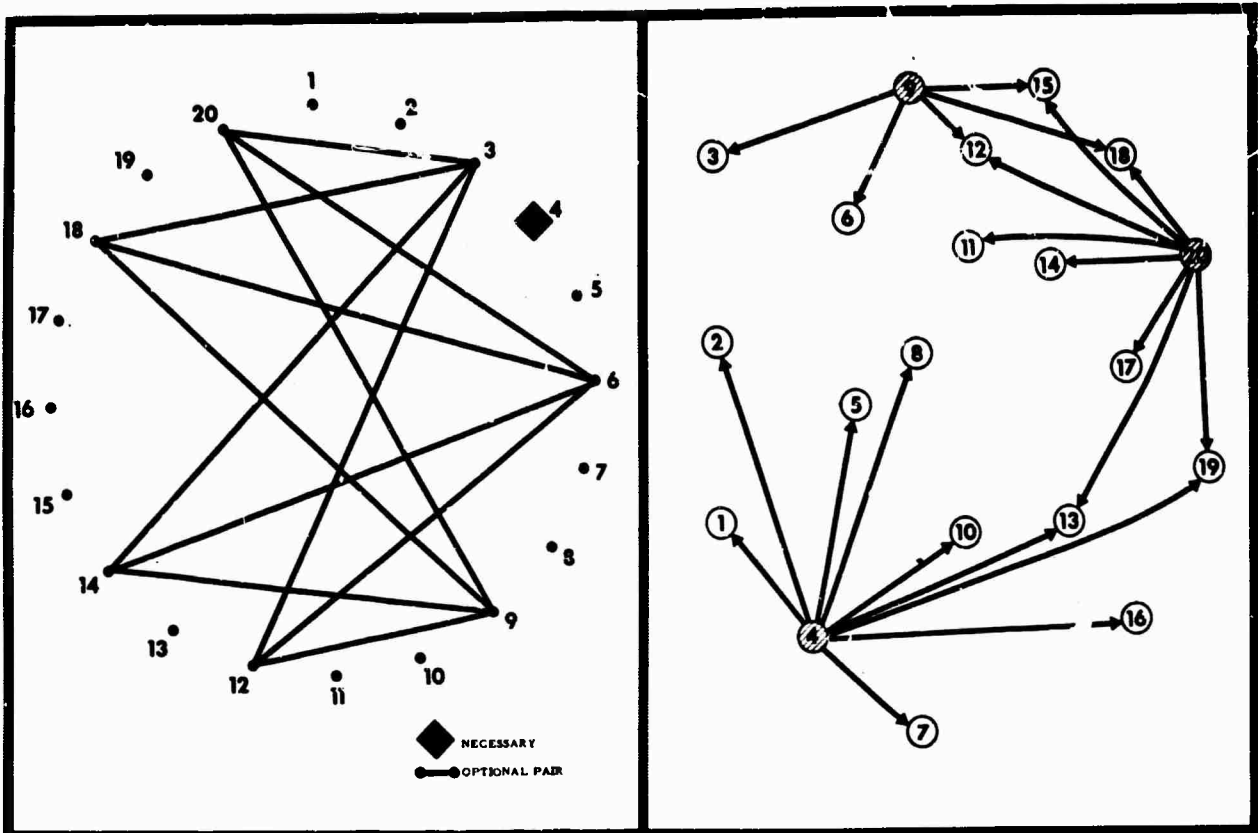

Figure 16. Solutions for $T_R = 3$

Figure 17. A Minimum Node Solution for $T_R = 3$

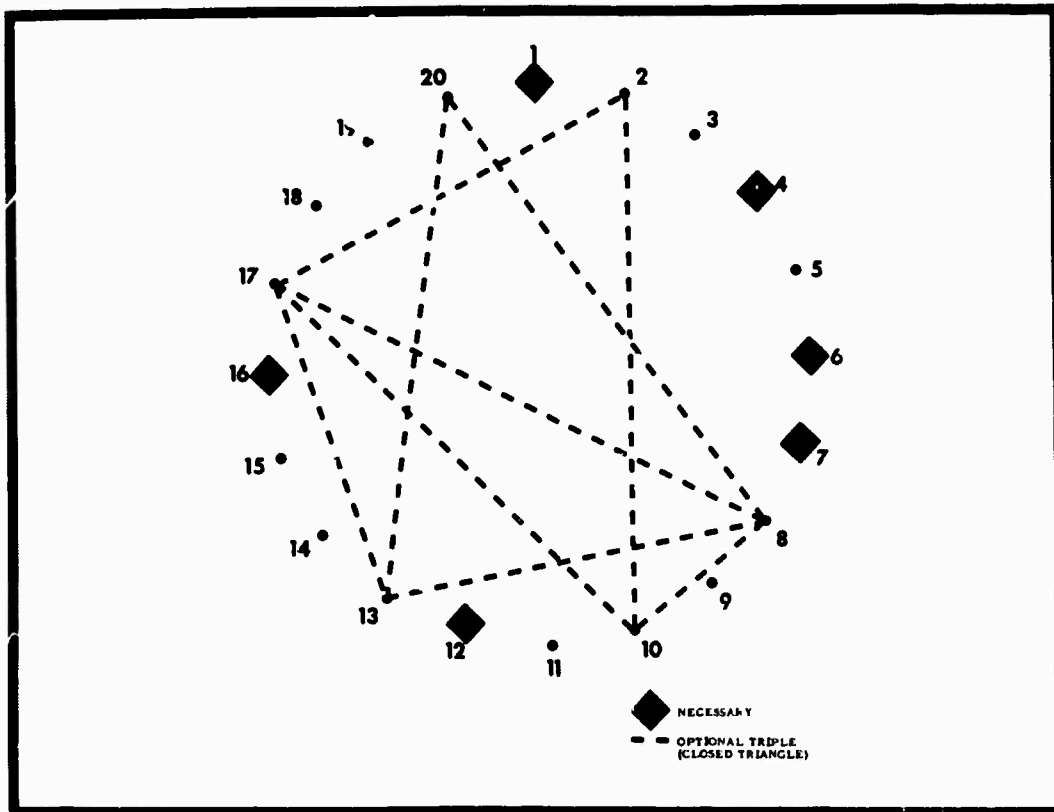

Figure 18. Solutions for $T_R = 1$

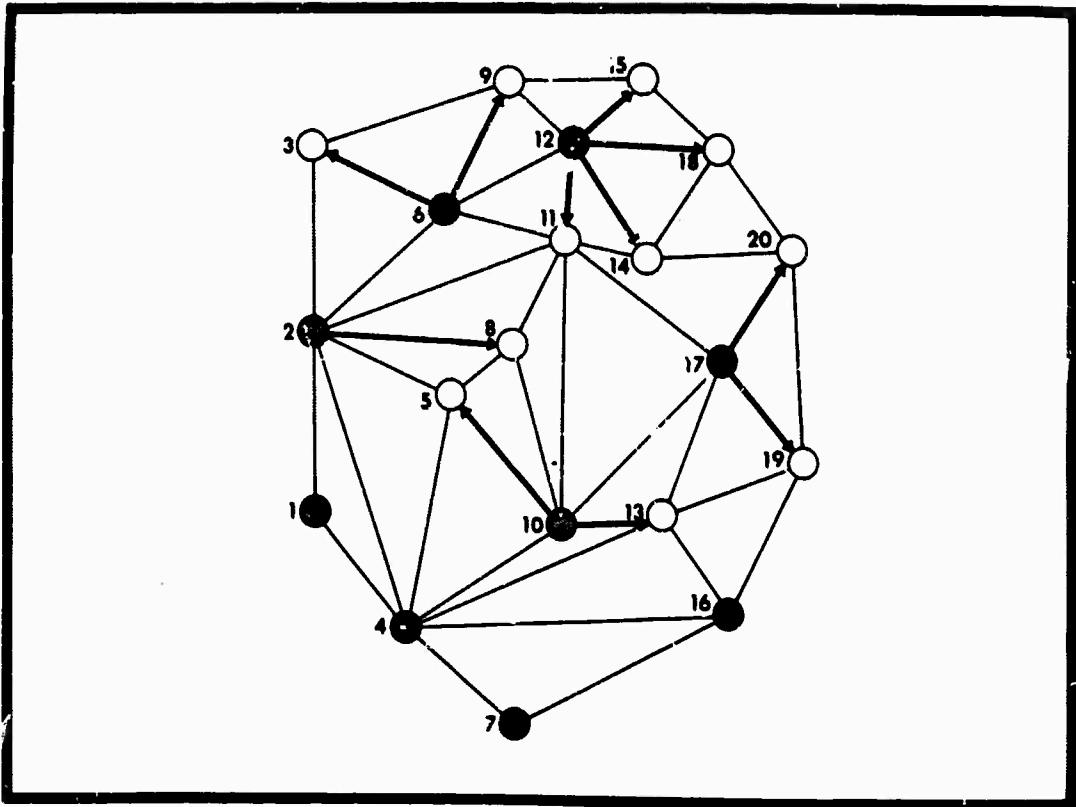

Figure 19. A Minimum Node Solution for $T_R = 1$.

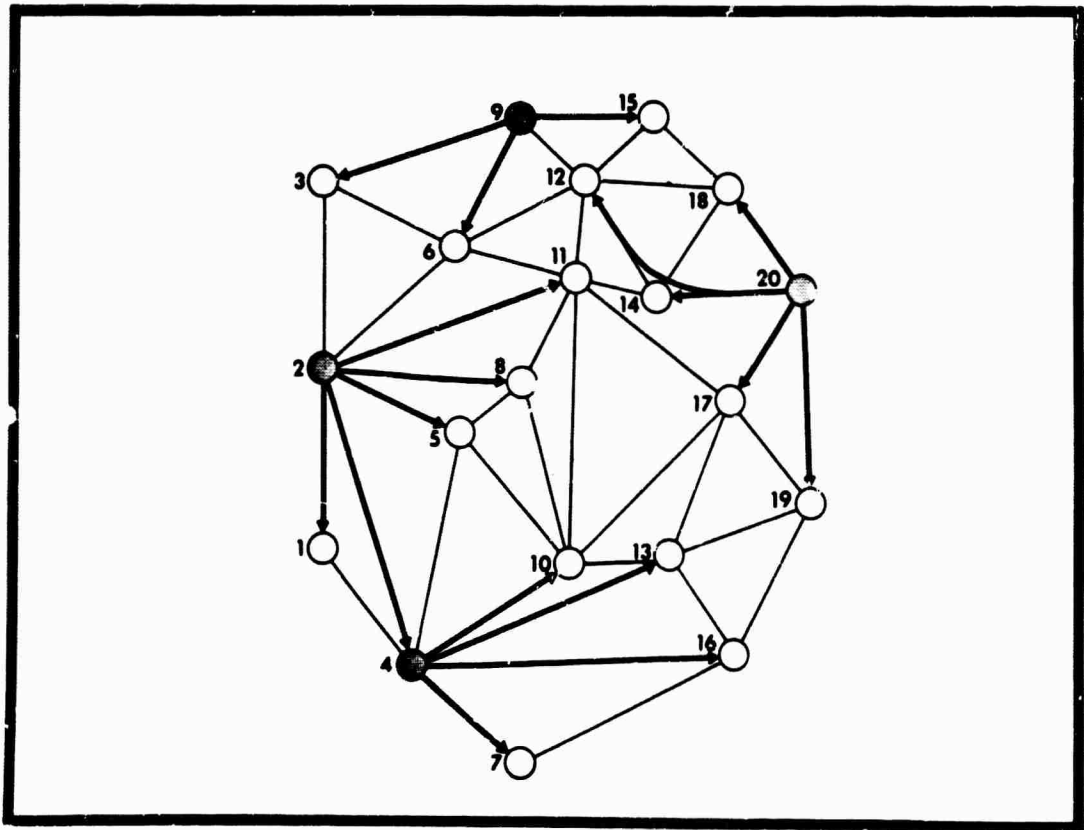

Figure 20. The Unique Solution for $T_R = 2$.

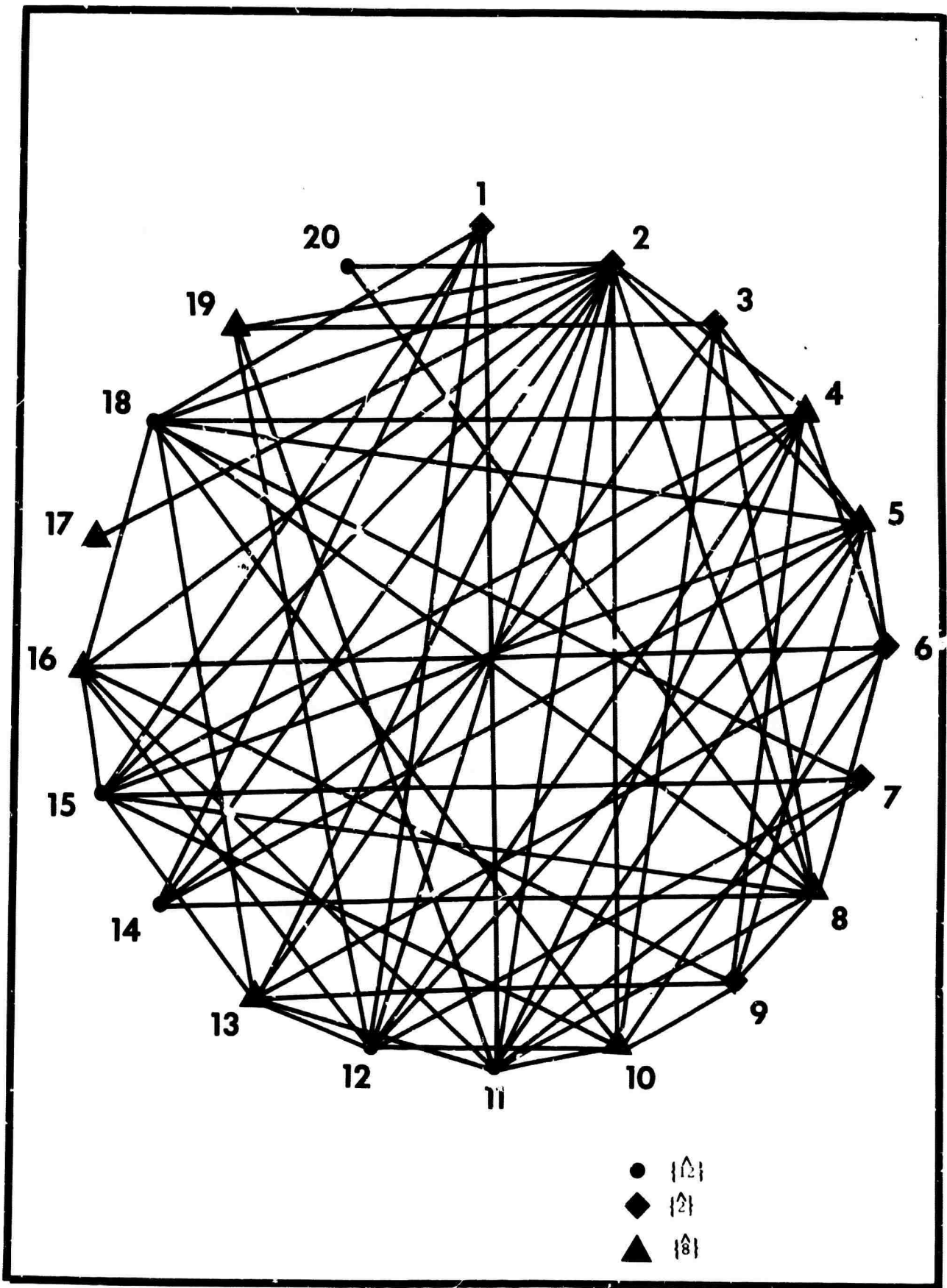

Figure 21. Solutions for $T_R = 5$.

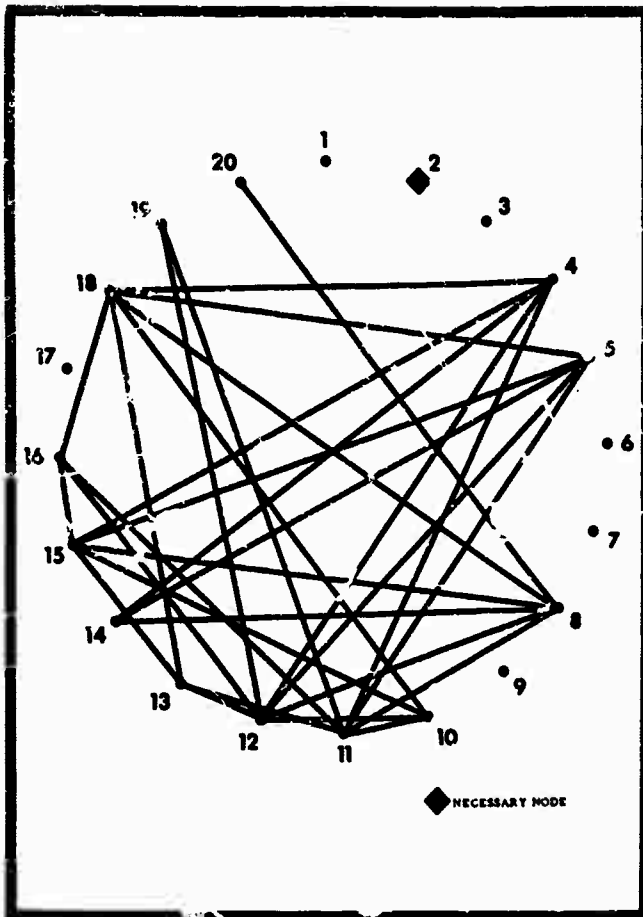

Figure 22. Triple Solutions for $T_R = 5$.

two supply nodes, so $3 \times 1/2 = 1-1/2$ units, rather than the 2 units required by a 2-node solution.)

The equivalence sets for these latter three cases are:

$$\underline{T_R = 1}$$

$$\{\hat{17}\} = \{14, 17, 20\}$$

$$\{\hat{6}\} = \{3, 6, 9\}$$

$$\{\hat{8}\} = \{2, 3\}$$

$$\{\hat{12}\} = \{11, 12, 15, 18\}$$

$$\{\hat{13}\} = \{5, 10, 13, 19\}$$

$$\underline{T_R = 2}$$

$$\{\hat{2}\} = \{1, 2, 8\}$$

$$\{\hat{4}\} = \{4, 7, 16\}$$

$$\{\hat{9}\} = \{3, 6, 9\}$$

$$\{\hat{20}\} = \{5, 10, 11, 12, 13, 14, 15, 17, 18, 19, 20\}$$

$$\underline{T_R = 5}$$

$$\{\hat{2}\} = \{1, 2, 3, 6, 7, 9\}$$

$$\{\hat{8}\} = \{4, 5, 8, 10, 13, 16, 17, 19\}$$

$$\{\hat{12}\} = \{11, 12, 14, 15, 18, 20\}$$

Nodes not listed form one-member sets.

The total solution set is listed in Table 2 for each reaction time. The total set of solutions, such as those listed in Table 2, can be utilized for many purposes. Some of the possible users are:

- (1) Fix a reaction time requirement; select the particular solutions from the solution set which best satisfy political, social, and economic criteria and requirements.
- (2) Choose a solution for one reaction time which will, with minimum modification, provide a solution for another reaction time. In terms of the 20-node example

Table 2. Solutions to the 20-Node Symmetric Network

$$\underline{T_R = 7 : 1 \text{ Station}}$$

$$1 + 2 + 4 + 5 + 8 + 11 + 12 + 20$$

$$\underline{T_R = 6 : 1 \text{ Station}}$$

$$2 + 8 + 11$$

$$\underline{T_R = 5 : 2 \text{ Stations}}$$

Almost every pair equivalent to:

$$[8][2 + 12] + [2][12]$$

$$\left([2] \left[[8][14 + 20] + [14][4 + 5] + [19][11 + 12] + [11 + 12 + 15 + 18][4 + 5 + 8 + 10 + 13 + 16] \right] \right)$$

$$\underline{T_R = 4 : 2 \text{ Stations}}$$

$$[4][15] + [2][12 + 14 + 18]$$

$$\underline{T_R = 3 : 3 \text{ Stations}}$$

$$[4][3 + 6 + 9][12 + 14 + 18 + 20]$$

$$\underline{T_R = 2 : 4 \text{ Stations}}$$

$$[2][4][9][20]$$

$$\underline{T_R = 1 : 9 \text{ Stations}}$$

$$[1][4][7][11][6][12] + [8][17][17 + 20] + [10][17][2 + 8]$$

above, suppose that a reaction time of 3 is sufficient, but that there is some likelihood that a reaction time of 2 might be required; choosing [4][9][20] as the solution for $T_R = 3$ will permit the system to satisfy the requirement for $T_R = 2$ with only the addition of a supply node at [2].

- (3) Choose a solution for one reaction time which will provide double coverage at a different reaction time. For example, if [2][12] is chosen as the solution for $T_R = 4$, then double coverage would be provided for $T_R = 7$.

Allowable Supply and Demand Nodes

More general requirements on the particular solutions for a developing area may be imposed by specifying (1) which nodes are required to be supply nodes, (2) which nodes are allowable supply nodes, and (3) which nodes are allowable demand nodes.

Table 3 provides a limited indication of the way in which solutions are affected by variations in allowable nodes. The entries in Table 3 provide the minimum number of supply nodes required for the 7 reaction times and for four different supply-demand node allowable configurations. Results for

both the symmetric and unsymmetric networks are listed. Note that no solution may exist for a given reaction time when the supply nodes are restricted and that restricting the number of demand nodes reduces the number of minimum nodes required.

If the set of allowable demand nodes remains fixed, then any solution obtained with supply node configuration S_1 is also a solution when the supply node configuration is S_2 whenever $S_1 \subset S_2$. For a fixed supply node configuration, any solution with demand node configuration D_1 is a solution for demand node configuration D_2 whenever $D_1 \supset D_2$.

DISCUSSION

This analysis of the 20-node hypothetical network was performed to present some of the alternatives available to a transportation systems analyst in the use of the current NETSIM program and to illustrate the choices which would be available from the general SIMDATS program. Automatic computer implementation of the analysis and the plotting by the computer of the maps, charts, and tables would, in most cases, be easily accomplished and would provide the systems analyst with a wide variety of tools.

Table 3. Number of Nodes in the Minimum Node Solution.

T_R	CONFIGURATION							
	SYMMETRIC NETWORK				UNSYMMETRIC NETWORK			
	S = 1 D = 1	S = A D = 1	S = 1 D = B	S = A D = B	S = 1 D = 1	S = A D = 1	S = 1 D = B	S = A D = B
1	9	No So- lution	4	5	9	No So- lution	6	No So- lution
2	4	5	3	4	6	No So- lution	4	5
3	3	3	3	3	5	6	3	4
4	2	2	2	2	3	3	2	3
5	2	2	1	1	3	3	2	2
6	1	1	1	1	2	2	1	2
7	1	1	1	1	1	1	1	1

S = Set of Supply Nodes

D = Set of Demand Nodes

1 = All Nodes are Allowable

A = {2, 4, 6, 7, 8, 10, 12, 16, 17}

B = {2, 3, 5, 6, 8, 9, 10, 11, 12, 13, 14, 15, 19}

APPENDIX G

THE DEVELOPMENT OF ECONOMIC CRITERIA

In trying to design a transportation network to satisfy the socioeconomic needs of developing nations, one encounters problems which are somewhat different from those met in more economically developed societies. The influence of those problems on two areas of interest in transportation systems are discussed here:

- 1) The determination of long-range demand (needs) at nodes of the network.
- 2) The selection of optimization goals for the entire system.

We touch slightly on some topics of economic theory to guide us in constructing the mathematical model, and we also give some crude algebraic examples of how models in these areas might be built. The mathematical expressions cover only specific questions; they may be omitted in following the general arguments.

DETERMINATION OF DEMAND

In developing areas, present-day demand for goods may be so small that the existing transportation system, no matter how poor it is, is quite adequate for satisfying actual producer-consumer needs. In addition, even if present needs are large enough to justify a better transportation network, the pattern of future needs would be greatly changed by the introduction of the transportation system itself. In either case, one needs a way of predicting future demands on the transportation system.

A demand model can be developed in which the infinitesimal increase in the demand for a commodity is proportional to the infinitesimal change of the inverse price per unit:

$$dt = \lambda(t) d\left(\frac{1}{p}\right) \quad (1)$$

where t is the demand in tons, p is the unit price (\$/ton) and $\lambda(t)$ (\$) is an empirical function of demand, designed to allow saturation effects to enter.

The unit price can be taken to be:

$$p = \frac{1}{x} \quad (2)$$

where x is the total cost-effectiveness of the product, including transportation costs. The solution to Eq. (1) for a "saturation function"

$$\lambda(t) = \lambda_0 e^{-\frac{t}{T}}$$

is then (T is a saturation parameter)

$$t = t_0 + \frac{\lambda_0}{T} \log \left\{ 1 + T(x-x_0) \right\} \quad (3)$$

which for small $T(x-x_0)$ reduces to

$$t \cong t_0 + \lambda_0(x-x_0) \quad (3')$$

where the zero subscript indicates initial values. The intention here is to show how the result in Eq. (3') might be changed by a different definition of p in Eq. (2) and then, conversely, how a somewhat more sophisticated economic analysis might tend to re-instate Eq. (3') as a reasonable model after all.

First, let us try the alternate model for p :

$$\text{Let } p = p_f + \frac{1}{x} \quad (4)$$

where p_f is a constant, limiting unit price, and now x is to represent only the cost-effectiveness inherent in transportation. The reasoning here is that, for example, the initial cost of a chevrolet in Ban Lao, Thailand may represent very large transport costs ($\frac{1}{x_0} \gg p_f$), but installing a superhighway to Ban Lao cannot bring the cost below the "F. O. B. Detroit" figure, or

$$p_{\text{Max}} = p_f$$

If now we insert Eq. (4) into Eq. (1), for $\lambda(t) \cong \lambda_0$ (negligible a priori saturation) we get

$$t = t_0 + \frac{\lambda_0}{p_f} \left\{ (p_f x_0 + 1)^{-1} - (p_f x + 1)^{-1} \right\} \quad (5)$$

which reduces to (3') only when $p_f x \ll 1$. Note that Eq. (5) produces a saturation effect "naturally", so that it might be a realistic alternative to Eq. (3').

Now we consider the role of economic considerations other than price; that there are such considerations should be evident from the fact that the improvement (increase of cost-effectiveness) of the transportation system in itself increases income and, therefore, demand. That is, the building of a road involves the creation (or importation) of "social capital". Now capital produces income, or in economic terms

$$\Delta Y = \left(\frac{K}{O}\right)^{-1} \Delta I \quad (6)$$

where ΔY is the change in income, ΔI is the change in capital, or investment, and K/O is the Capital/output ratio. This ratio, for transportation in underdeveloped areas, is typically of the order of 4:1¹. Of course, the ratio may not be constant, since the initial pumping of income into a locale where a road is being built as well as the effect on encouraging the investment of private capital in the region must be determined. Nonetheless, the effect shown in Eq. (6) is undoubtedly real and important.

In our terms, we can try assuming that the amount of money invested in a road proportional to the achieved cost-effectiveness, this assumption gives us at least a start on formulating a theory. Then

$$\Delta I \sim \Delta x, \quad (7)$$

and since increases in income are, in cases where saving is low, also increases in demand², we have

$$\Delta Y \sim \Delta t \quad (8)$$

and we get, combining Eqs. (6), (7) and (8) infinitesimally,

$$dt_c = c dx \quad (9)$$

where c is a proportionality constant (to be determined empirically) and we have written " dt_c " to show that this is the demand produced by capital expenditures.

One can now argue that even if Eq. (5) is a better model for price demand than Eq. (3'), that the demand dt_c given in (9) will dominate (or at least modify) the total demand $dt_b + dt_c$ (where dt_b is our "price demand") in such a way that the total demand

$$dt = dt_\lambda + dt_c$$

becomes

$$dt \approx b dx \quad (10)$$

where b is an empirical constant which includes both price and capital effects.

It is not argued that Eq. (10) includes all effects: indeed, as the society develops, the "constant" $(K/O)^{-1} < 1$ in Eq. (6) is replaced in the Keynesian theory by³

$$\Delta Y = k \Delta Y \quad (11)$$

where $k > 1$, and represents the "multiplying" effect of investments; such multiplication effects, however, can probably be neglected for the low-labor-cost situation of developing areas⁴. At any rate, it would seem that Eq. (10) is a plausible theoretical framework for the semi-empirical determination of demand in the absence of solid data on the subject.

With this in mind, we can write the SIM-DATS steady-state transportation equations as

$$\sum_{ij} \theta_{ij} \Delta y_{ij} = \sum_{ij} b_{ij} x_{ij} \quad (12)$$

$$\sum_{ij} \theta_{ij} \Delta y_{ij} - y_j = 0 \quad (13)$$

where the b_{ij} are the generalizations of the b in Eq. (10), that is,

$$t_i = \sum_j b_{ij} x_{ij} \quad (14)$$

is to be the total demand at node i in terms of the cost effectiveness of transportation in shipping from j to i , x_{ij} . Equations (12) and (13) are now to be used as constraints in optimizing some cost function, where the Δy_{ij} , y_j and the x_{ij} are all independent variables. That is, we wish to solve for both the required shipments, allocations, and the desired condition of the network segments, given some optimization goal. The goal to be chosen is the subject of the next section.

OPTIMIZATION GOALS

We consider possible behavior of the SIM-DATS equations for two possible goals: maximization of total cost-effectiveness, or maximization of total demand. The possibility of a non-cost-effective goal arises because of the peculiarities of the underdeveloped-area situation, as discussed below in sections (B) and (C).

A. Cost-Effectiveness

The most straightforward choice of an optimization goal is cost-effectiveness, or the movement of the maximum number of tons/\$. Equivalently we can minimize the total \$/ton, or, where the transportation cost is

$$C_T = \sum_{ij} c_{ij} \Delta y_{ij}, \quad (15)$$

c_{ij} the unit cost matrix, we can write, since

$$c_{ij} = 1/x_{ij} \quad (16)$$

that

$$C_T = \sum_{ij} \frac{\Delta y_{ij}}{x_{ij}} \quad (17)$$

and that the total demand T , is

$$T = \sum_i t_i = \sum_{ij} b_{ij} x_{ij} \quad (18)$$

Or equivalently, from Eq. (12)

$$T = \sum_{ij} \theta_{ij} \Delta y_{ij} \quad (18')$$

and

$$Q_T = \sum_{ij} \frac{\Delta y_{ij}}{x_{ij}} / \sum_{ij} b_{ij} x_{ij} \quad (19)$$

Now it is possible, in principle, to maximize Eq. (19); the actual calculation might be quite difficult. Moreover, for the actual sample cases worked in the ECON-LLP program, only the goals treated in the next sections were used.

B. Maximization of Demand

In the usual economic conditions in developed countries, the choice of cost-effectiveness as an optimization goal is obviously reasonable: "the most for the money" is evidently a rational short term goal. Even in economically developed countries, however, the feedback effect of any changes made in a particular system may be important in the long term. In underdeveloped areas, long-term goals are likely to be of the most interest, and minor efficiencies achieved in the

short run may be of little concern. In mathematical terms, the long-term goals may involve nonlinear effects; in economic terms, "pump priming" may be the process of interest.

The choice of optimization criteria in such an environment could be rather wide. As an example, we select the "maximization of demand". Our motivation for choosing demand lies in the observed nonlinearity of the process known as the "taking-off" into industrialization (or rather into "development" of all kinds, since the affluence of a well-developed economy may depend rather heavily on a great efficiency in agriculture⁶). Now the criteria for this taking off may be somewhat difficult to determine, but at least a certain level of income (demand) seems to be a prerequisite⁷. We therefore suppose that a possible goal for a transportation system is to increase demand as much as possible, so that the country involved can reach the take-off-into-growth point.

As a constraint on this total demand which we wish to maximize, we imagine that a fixed amount of foreign capital is invested in improving the given road (or rail, or air) network. Let us suppose that the amount spent on each road segment is proportional to some power N of the total cost effectiveness of the segment. Then we have, where K is the total amount of money available for spending, the inequality constraint

when

$$K \geq \sum_{ij} z_{ij} \quad (20)$$

$$z_{ij} = A_{ij} (x_{ij}^N - x_{ij}(0)^N) \quad (21)$$

The choice of this nonlinear dependence here may also affect demand in a non-linear way; however, for simplicity, let us assume that the demand is given by Eq. (3') or Eq. (14), so that we have as our objective function the total demand

$$T = \sum_i t_i = \sum_{ij} b_{ij} x_{ij} \quad (22)$$

to be maximized.

Equations (20) and (21) and (22) could be treated in principle by the Lagrange multiplier method, as adapted to inequalities. In practice, unless $N = 1$, the problem may be intractable; if $N = 1$, the problem may be treated by linear programming methods.

Another difficulty arises in using Eq. (22) in the present initial formulation: the incremental model introduces nonlinearities into the cost-effectiveness expressions x_{ij} . That is, the cost-effectiveness for two segments of road in series is

not the sum of the cost-effectiveness of each segment separately (the "resistor law"), but is the reciprocal of the sum of the reciprocals (the "capacitor law").

To evade this difficulty, Eq. (22) was replaced by a related but different form as described in section C below.

C. Consumer Price Level (Average Transport Cost) Minimization

The connection between consumer prices and cost-efficiency was discussed in section I of this appendix, as was the relation between consumer prices and transport cost. The arguments in section I indicate that the typically high costs of transport systems in emerging nations may make transport cost approximately equal to consumer prices. Within the crudity of this model, then, the terms "consumer price level" and "average transport cost" will be used interchangeably.

Now we can use the fact that the transport cost is just the reciprocal of the cost-efficiency of the route used to adapt Eq. (22) above to the incremental model. That is, the transport costs, in contrast to the cost efficiencies, of two segments added together, is just the simple sum of the costs of the two segments considered separately. Therefore, one might consider the expressions:

$$P = \sum_{ij} A_{ij} p_{ij} \quad (23)$$

and the corresponding incremental sum

$$\Delta P = \sum_{ij} A_{ij} \Delta p_{ij} \quad (24)$$

where the p_{ij} are the transport costs ("prices") associated with each road, A_{ij} is some "segment factor", and P is the total price level, the deltas indicating increments. A possible mathematical expression of an economic goal is now to require that P be minimized (be made more negative) by changing the p_{ij} which are connected to the x_{ij} and $x_{ij}(0)$ of Eq. (21) as in Eq. (2).

This model was, in fact, chosen for the ECON-ILP calculation. A fuller explanation of how A_{ij} was calculated, how "N" in Eq. (21) was determined and so on, is given in Appendix H.

Footnotes

(References are to articles in The Economics of Underdevelopment, Agarwala and Singh, ed., Oxford Univ. Press, New York, 1963).

1. Chenery, Hollis B., "The Role of Industrialization in Development Program", p. 457, Table.
2. Rao, V. K. R. V., "Investment Income and the Multiplier in an Underdeveloped Economy", p. 206.
3. Rao, op. cit., p. 205.
4. Rao, op. cit., p. 208.
5. Rostow, W. W., "The Take-Off into Self-Sustained Growth", pp. 154-186.
6. Clark, Colin, "Population Growth and Living Standards", pp. 36 ff.
7. Rostow, op. cit., pp. 164 ff.

APPENDIX H

THE ECON-ILP MODEL

The ECON-ILP model calculation consists of the minimization of a price-level function (Eq. (24) of Appendix G) under the construction money constraint (Eqs. (20) and (21), Appendix G).

First, consideration is given to the determination of the connection between cost-effectiveness and road construction expenditure, together with the allowed "quantum" values associated with road construction. Then the derivation of the "averaging factor" A_{ij} is considered, and the complete price function determined. The final section gives the explicit form of the equations solved by the ILP-2 program.

1. Road Construction and Cost-Effectiveness

We wish to determine the values of the parameters in the equation (see Appendix G Eq. (21))

$$z_{ij} = a_{ij} (x_{ij}^N - x_{ij}^0) N_{ij} \quad (1)$$

that is, N and a_{ij} , and also to relate the variables z_{ij} and x_{ij} to measurable quantities.

The meaning of the equation above is that the "improvement expenditures" z_{ij} increase the cost-effectiveness of the segment ij by an amount $x_{ij} - x_{ij}^0$. The improvement expenditures z_{ij} can be of a quite general nature, but as a particular example (in order to find a typical a_{ij} and N) let us take z_{ij} to represent the cost of construction (amortized per year) for a unit length of road, c_C times the length of the road, l_{ij} . I. e.,

$$z_{ij} = c_C l_{ij} \quad (2)$$

where the c_C has yet to be specified as a function of the type of construction employed.

The cost-effectiveness x_{ij} can be expressed in terms of the total tons of a commodity shipped from j to i , Δy_{ij} , and the money spent on transportation by shippers, m_{ij} . That is,

$$x_{ij} = \Delta y_{ij} / m_{ij} \quad (3)$$

Δy_{ij} is of course related to the total demand:

$$d_i = \sum \Delta y_{ij}$$

Now the money spent on transportation can be divided into road costs and vehicle costs:

$$m_{ij} = m_{R_{ij}} + m_{V_{ij}} \quad (4)$$

And, if the shippers (or alternately, buyers) pay a proportion q_C and q_M of the construction and

maintenance per km. (c_C and c_M) then

$$m_{R_{ij}} = (q_C c_C + q_M c_M) l_{ij} \quad (5)$$

where again c_M and the q 's must still be specified. Similarly for the vehicle costs:

$$m_{V_{ij}} = (q_P c_P + q_O c_O) N_{V_{ij}} \quad (6)$$

where the q 's again represent the fraction of the costs paid by shippers, c_P is the (amortized) purchase cost of a vehicle per year and c_O is the operating cost, (gasoline, oil, tires and repairs) per year. In general, c_O depends on mileage; we take, for simplicity, some average number of miles/year as a basis for costing. The symbol $N_{V_{ij}}$ indicates the number of vehicles purchased and maintained (here taken to be the same) for use on ij .

For purposes of deriving a value for a_{ij} without knowledge of future usage, we should like to get representative values of x_{ij} independent of Δy_{ij} values. Since $m_{R_{ij}}$ does not depend on tonnage (road costs are $m_{R_{ij}}$ only weakly dependent on shipments if surface capacity is not overstrained), we let $q_C = q_M = 0$ (no construction and maintenance costs paid by shippers) and have

$$x_{ij} = \Delta y_{ij} / m_{V_{ij}} \quad (7)$$

Now take $q_P = q_O = 1$ (all vehicle costs paid by shippers) and for the number of vehicles needed on the segment ij ,

$$N_{V_{ij}} = \Delta y_{ij} / a_t N_T \quad (8)$$

where a_t is the capacity of the vehicle in tons and N_T is the number of trips/year for each vehicle. Then, to get the number of trips, we have

$$N_T = a_l / l_{ij} \quad (9)$$

where a_l is the number of kilometers traveled/year. Combining Eqs. (9), (8) and (6) and inserting into Eq. (7), remembering $q_P = q_O = 1$, we get

$$x_{ij} = a_t a_l / l_{ij} (c_P + c_O) \quad (10)$$

which can be used, together with Eq. (2) to derive the empirical parameters in Eq. (1). Using the calculations given in the Battelle report RACITR-59, we take first the values given for minimal road construction and conventional all-weather-road construction (from their page 30),

$$c_C = \begin{matrix} \$0.283 \times 10^3 / \text{yr.} \cdot \text{km.}, \text{ minimal} \\ \$2.17 \times 10^3 / \text{yr.} \cdot \text{km.}, \text{ conventional} \end{matrix}$$

Then we write down the equation combining Eqs. (10), (2) and (1) as

$$c_C = (a_{ij}^{\ell-N-1}) (a_t a_\ell / (c_P + c_O)), N \quad (11)$$

(where $x_{ij}(0)$ has been taken approximately equal to zero). Values for the parameters on the right-hand side are now inserted: a vehicle which can operate efficiently on a minimal road (a "Marsh Skeeter") are compared to a conventional truck operating on the conventional road. From Table 4 in the RACIC report, we have

$$\begin{aligned} a_t &= 0.893 \text{ metric tons/vehicle,} \\ &\quad \text{"Marsh Skeeter"} \\ &= 4.46 \text{ metric tons/vehicle, ruck} \\ a_\ell &= 4.68 \times 10^4 \text{ km./yr., "Marsh} \\ &\quad \text{Skeeter"} \\ &= 7.48 \times 10^4 \text{ km./yr., truck} \end{aligned}$$

and

$$\begin{aligned} c_P + c_O &= \$5.93 \times 10^3 / \text{yr., "Marsh Skeeter"} \\ &= \$5.50 \times 10^3 / \text{yr., truck} \end{aligned}$$

Now solving Eq. (11) for the unknown empirical parameters, we get

$$N \approx 1 \quad (12)$$

and the distance $l =$ independent quantity $a_{ij}^{\ell-N-1}$ is

$$a_{ij}^{\ell-N-1} a_{ij}^{\ell-N-2} = 36 \text{ (\$/ton)} \quad (13)$$

The values in Eqs. (12) and (13) can now be used in Eq. (1). One must now, however, consider possible restrictions on the projected expenditures z_{ij} ("quantum effects").

In general, z_{ij} cannot be just any value: the road costs are restricted by the limited number of kinds of roads which can be constructed and by the fact that only complete road segments should be constructed. The expenditures of money are therefore quantized. First, for construction actually carried out,

$$z_{ij} = c_C l_{ij} \quad (14)$$

where l_{ij} is the length of the segment and c_C is the construction cost in dollars/kilometer. We want to express this last cost in terms of integral multiples of a basic road cost, or

$$c_C = c_{CBR} \Delta q_{ij} \quad (15)$$

in which c_{CBR} is a basic road cost/kilometer and where the dependence of potential road cost on ij is now explicitly shown. Furthermore,

$$\Delta q_{ij} = \text{integer}$$

We also want to restrict q_{ij} to only certain integers; as an example, let us restrict it to two only. These two values can be derived from the values given for c_C above; fitting those numbers to an integral formula, we can derive

$$\Delta q_{ij} = 0, 3, 23$$

and

$$c_{CBR} = (283/3 = 94.3 \text{ (\$/km.)})$$

The first value of Δq_{ij} corresponds to no road improvement, the second to minimal road construction, and the third to all-weather road construction. We must still take into account, however, the fact that some roads in the system are already improved. To do this, we can modify Eq. (15) by taking into account the initial road condition. We label the initial condition by the new input $q_{ij}(0)$, which can be conveniently taken to be 1, 4, and 24, for the initial road being subminimal (trail, ox cart track, etc.), minimal and all-weather, respectively.

Then we get

$$c'_C = c_{CBR} (q_{ij} - q_{ij}(0)) \equiv c_{CBR} \Delta q_{ij} \quad (16)$$

and then, from Eq. (2),

$$z_{ij} = c_{CBR} \Delta q_{ij} l_{ij} \quad (17)$$

for use in (see Appendix G, Eq. (20)), the final money constraint

$$K \geq \sum z_{ij} \quad (18)$$

2. The Price Function

To evaluate the price function, one needs, first of all, to determine the value of the "segment factor", A_{ij} . This quantity is to be chosen so that the expression (see Appendix Eq. (24)

$$\Delta P = \sum_{ij} A_{ij} \Delta p_{ij} \quad (19)$$

gives the average change in regional prices caused by changing the price (or transport cost) Δp_{ij} along any road segment denoted by the indices i, j . It is plausible that A_{ij} should be proportional to the transport usage along any road segment; the ECON-ILP program calculates this usage by making simulated shipments from certain "entry ports" (supply stations) in the network to all populated nodes in the region.

The technique employed in this simulation can be correctly, but awkwardly, characterized by expressing A_{ij} as

$$A_{ij} = \sum_r \sum_{k_i, k_j} B(k_i, k_j, r, i, j) \quad (20)$$

where the sums are, in general, over all nodes k_i and k_j and which contain the segment i, j . The imposing-looking matrix B is some averaging factor, still to be specified.

If we take the k_i to be the demand nodes and the k_j to be the supply nodes, then it is possible that a reasonable choice of B is

$$B(k_i, k_j, r, i, j) = f_{k_i k_j} \cdot W_{k_i} \cdot M_{k_j} \quad (21)$$

where W_{k_i} is an economic weighting factor associated with the demand node, and M_{k_j} is a similar factor associated with the supply node. The factor

$$f_{k_i k_j} = x_{k_i k_j}(0) / \left(\sum_r \sum_{k_j} x_{k_i k_j}(0) \right) \quad (22)$$

is chosen so that each route from k_i to k_j is weighted with the ratio of its own cost-effectiveness to the (original) cost-effectiveness of all other routes.

Given Equations (21) and (22), the sum in Equation (2) can be carried out, and A_{ij} determined. The values used in the sample calculation are given in the figures and tables in the Case Study section: W_{k_i} is given in Figure 22; M_{k_j} is taken as unity (equally important supply points); the $x_{k_i k_j}(0)$ adopted, in Table 10; and the resulting A_{ij} in Table 11.

Unfortunately, the mathematical formulation somewhat obscures the simplicity of what is actually done. Consider a network of three points, 1, 2, and 3. One simulates a shipment from 1 to 3 directly, and then one from 1 to 3 by way of 2. If the cost-effectiveness of the direct route is three times that of the indirect route, its "f" value is 3/4, while the indirect route has an "f" value of 1/4. If the "W" value of point 3 is 8, the "B" value of segment 1 = 3 is 3/4 x 8 = 6, while the "B" value of segments 1-2 and 2-3 is 1/4 x 8 = 2.

When shipments from 1 to 2 are also considered, the "f" values and "W" values will be different, producing a new "B" value. This new "B" value is added to the old "B" value to produce an "A" value.

At any rate, once the A_{ij} values are determined, the values from Equation (1), using Equation (13) and Equation (17) can be written

$$x_{ij} - x_{ij}(0) = a'_{ij} l_{ij}^{-1} c_{CBR} \Delta q_{ij} \quad (23)$$

and

$$-\Delta p_{ij} = x_{ij}^{-1} - x_{ij}^{-1}(0) \quad (24)$$

Therefore, one can express Equation (16) in terms of q_{ij} and $q_{ij}(0)$:

$$\Delta P = -C \sum A_{ij} l_{ij} \left(q_{ij}^{-1}(0) - q_{ij}^{-1} \right) \quad (25)$$

where the constants have been lumped together and q_{ij} is allowed to have the values of 1, 4, and 24, as outlined above. (Since the problem is now whole-number, the non-linearity in q_{ij} is harmless.)

3. The ILP Program

The system of equations (25) and (17-1) can be now solved as an integer linear programming problem. The explicit formulation is

$$\Delta P = -\sum_{ij} F_{ij} u_{ij} + G_{ij} w_{ij} \quad (25')$$

and

$$K \geq \sum H_{ij} u_{ij} + I_{ij} w_{ij} \quad (18')$$

where u_{ij} and w_{ij} are to be taken on only the values 0 and 1, and the F_{ij} , G_{ij} , H_{ij} , and I_{ij} matrices are the combinations necessary to make Equation (25) and (25'), (18) and (18') agree. The H_{ij} and I_{ij} values used in the sample problem are given in the budget column of Table 12; the F_{ij} and G_{ij} are shown, divided by P , the original price level, and multiplied by 100, as a percentage price level change in the same table.

In addition, we have the feasibility constraints

1. If $q_{ij}(0) = 24$, $u_{ij} = w_{ij} \equiv 0$ or no improvement possible.
2. If $q_{ij}(0) = 4$, $w_{ij} \equiv 0$ or only one type of upgrading possible. (26)
3. If $q_{ij}(0) = 1$, $u_{ij} \geq w_{ij}$ or "no construction steps may be skipped."

The set of equations (25'), (18') and (26) are now to be solved. The computer program is described in Appendix I.

APPENDIX I

DOCUMENTATION OF THE ECON-ILP COMPUTER PROGRAM

In this appendix, we describe how the maximization of price change program was carried out on the computer. The sections of this appendix are

1. General Description of ECON-ILP
2. ILP-2
 - A. Deck Setup
 - B. User's Manual
3. ILPUNCH
 - A. Deck Setup
 - B. Data Format
 - C. Sample Listing

1. General Description

The simulated shipments calculation, necessary for deriving the "segment factors" in the price function, was not developed explicitly for the electronic computer. The route-tracing necessary in the calculation appeared to require more expenditure of programming and running time than could be justified for the small sample calculations undertaken. The calculations were therefore carried out by hand; the tediousness of the computations were somewhat lightened by the recognition that the primitive neural system had some advantages over more expensive devices, particularly in skills such as map reading and route recognition.

Once the price-objective function and the construction cost constraints are determined as described in Appendix H, the problem can be solved by integer linear programming techniques. The integer linear program used was ILP-2, a proprietary program of Control Data Corporation, for use on their 3600 computer. This program is described in section 2. Because every member of the rectangular matrix of linear equations must be specified by one labeled card in the ILP-2 program, while most of the elements in our case are zero, it was convenient to develop a short program to punch the data cards for ILP-2. This short program, ILPUNCH, need only be supplied with non-zero matrix elements; it is described in Section 3.

2. ILP-2 Program

The ILP-2 program is a proprietary program of Control Data Corporation for use on their 3600 computer, designed to solve optimization of whole number problems. Since no Fortran listing is available, only the binary deck itself and the user's manual, described below, could be included in this report.

A. Deck Setup

The setup of control cards as used for the 3600 machine at the CDC Los Angeles facility is shown in Figure 1.

B. User's Manual

The ILP-2 program is available only in binary deck form from CDC; their user's manual, available from CDC, is therefore indispensable.

Note that the control card setup described above supersedes the deck setup given in the manual, at least for the CDC Los Angeles facility. Note also that the data deck setup given in the manual, from the "ROW ID" card through the last matrix card, is produced as the output of the ILPUNCH program described below.

Note also that the "CONTROLS" card is really a data card, despite its name; for its use, see the user's manual.

C. Card Deck

A binary ILP-2 program, plus control cards, is available from CDC.

3. ILPUNCH Program

This program punches data cards for the ILP-2.

A. Deck Setup

The setup of control cards as used for the 6600 computer of the Control Data Corporation in Los Angeles is shown in Figure 2.

B. Data Format

The format for the data to be entered in the ILPUNCH program is as follows:

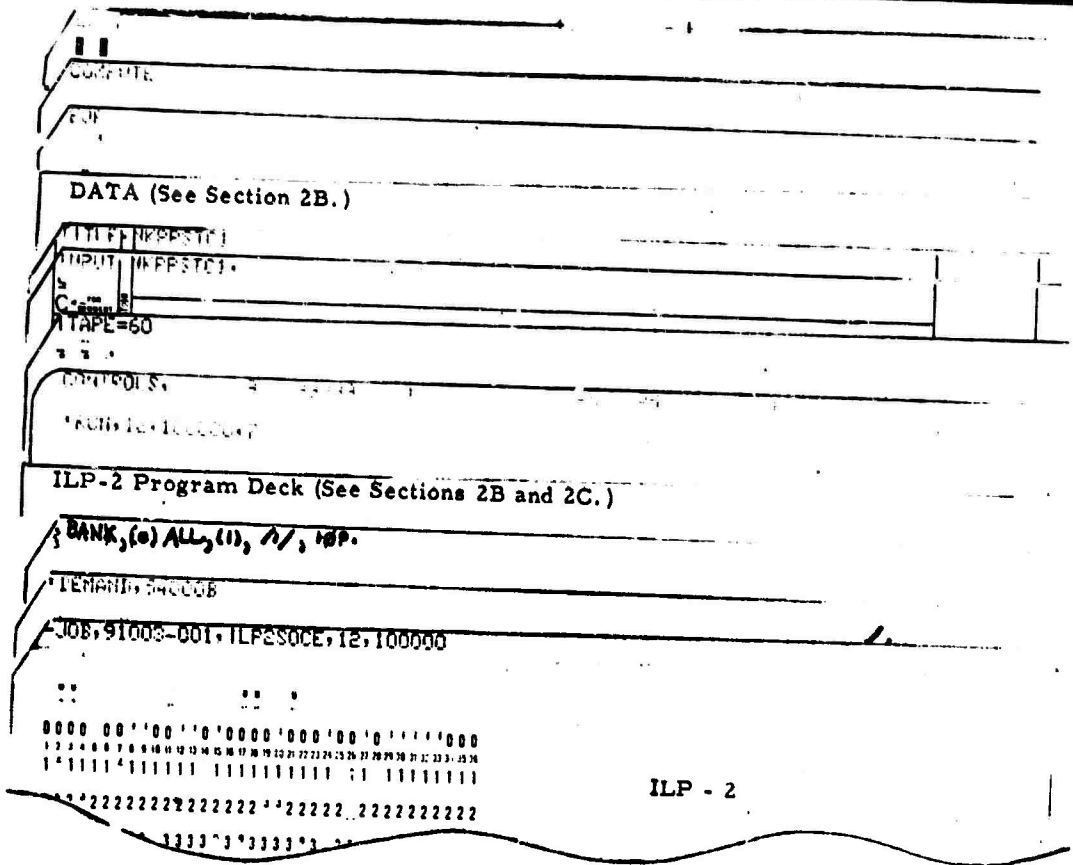

Figure 1. ILP-2 Deck Setup

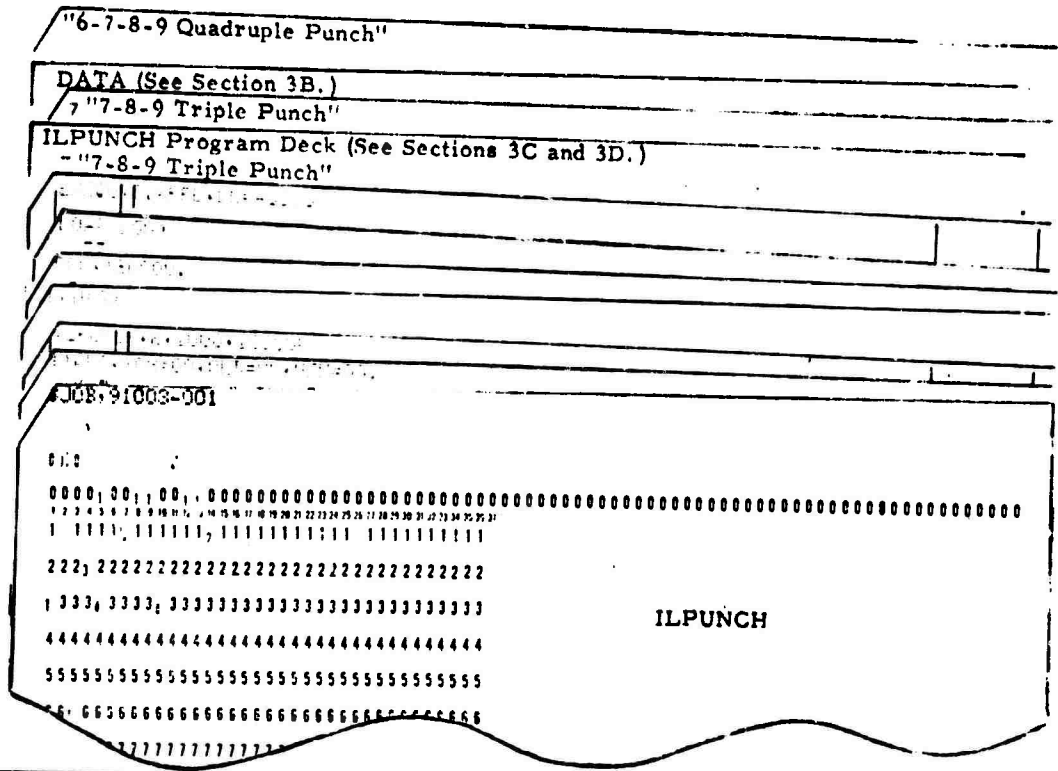

Figure 2. ILPUNCH Deck Setup

First card: Format (X, 19, 2I10).

The number of equation rows, NI, is to be entered in the I9 field, and the number of columns in the first I10 field. If the problem is maximization problem, enter 1 in the last I10 field; if it is a minimization problem, enter -1 in that field.

Second card(s): Format (X, I4, 13I).

The indices of "abnormal rows" should be entered in the I fields, numbered consecutively. There must be a zero (or blank) last entry field to signal end of these cards. "Abnormal rows" are equations involving upper bounds on variables in a minimization problem, or lower bounds in a maximization problem; this category can therefore be eliminated if desired by a change of sign, but the blank-field "signal" must still be entered.

Third card(s): Format (4 (2I3, I9)).

These cards input all non-zero matrix elements to the problem. The first I3 field is the row index, the second the column index, and the I9 field is the matrix element value. The objective function row is labeled 0 (zero), the constant values in the constraint equations (the "right hand sides") are labeled as column C (zero), the other elements labeled as desired.

The end of these cards and the end of the data are signaled by a punch 999 in the first I3 field after the last matrix entry; replace 999 by 888, if another data set is to be read.

C. Sample Listing

A listing of the ILPUNCH program is given in Figure 3.

GRAPHIC NOT REPRODUCIBLE

```

PROGRAM ILPUNCH (INPUT,PUNCH,TAPE60=INPUT)
C SIMULTS INTEGER LINEAR PROGRAM PUNCH DATA CARDS SUBPROGRAM
C YCLEPT ILPUNCH. SIGNAL MAXYES = 1 FOR MAX, -1 FOR MIN. N(I) ARE
C ABNORMAL ROWS. LESS FOR MIN. GREATER FOR MAX. NI,NJ=MAX INDICES
C M(I,NJ) IS MATRIX. ZERO IN IS CONSTANT. COLUMN ZERO IN IS
C COST FUNCTION COEFFICIENTS.
DIMENSION IN(4),JN(4),MX(4),CONST(100),LZMIN(100),MATRIX(100,100)
A ICSG(100),N(14)
12 HEAD INPUT TAPE 60,1000,NI,NJ,MAXYES
1000 FORMAT(X,19,2I10)
DO 1 I=1,NI
  LCONST(I)=0
DO 2 J=1,NJ
  LZMIN(J)=0
  MATRIX(I,J)=0
2 CONTINUE
1 CONTINUE
DO 3 I=1,NI
  ICSG(I)=MAXYES
3 CONTINUE
50 HEAD INPUT TAPE 60,1200,N(1),N(2),N(3),N(4),N(5),N(6),N(7),N(8),
  N(9),N(10),N(11),N(12),N(13),N(14)
1200 FORMAT(X,14,13I5)
DO 30 M=1,14
  I=N(M)
  IF(I.EQ.0) GO TO 3
  ICSG(I)=-ICSG(I)
30 CONTINUE
  GO TO 50
3 HEAD INPUT TAPE 60,2000,IN(1),JN(1),MX(1),IN(2),JN(2),MX(2),IN(3),
  JN(3),MX(3),IN(4),JN(4),MX(4)
2000 FORMAT(4,2I3,19)
DO 4 K=1,4
  I=IN(K)
  J=JN(K)
  IF(I.EQ.999) GO TO 5
  IF(I.EQ.999) GO TO 6
  IF(I.EQ.0) GO TO 7
  IF(J.EQ.0) GO TO 8
  MATRIX(I,J)=MX(K)
  GO TO 4
5 I=DATA=1
  GO TO 20
6 I=DATA=0
  GO TO 20
7 LZMIN(J)=MX(K)
  GO TO 4
8 LCONST(I)=MX(K)
  GO TO 3
20 CONTINUE
PUNCH 3000
3000 FORMAT(4NH0W 10)
IF(MAXYES.EQ.1) GO TO 55
PUNCH 4000
4000 FORMAT(1AM *ZMIN)
GO TO 55

```

```

55 PUNCH 4001
4001 FORMAT(16M *ZMIN)
56 CONTINUE
DO 9 I=1,NI
  IF(ICSG(I).EQ.1) GO TO 65
  PUNCH 5000,I
5000 FORMAT(15M *ROW,I3)
  GO TO 60
65 PUNCH 5001,I
5001 FORMAT(15M *ROW,I3)
56 CONTINUE
9 CONTINUE
PUNCH 6000
6000 FORMAT(6MMATRIX)
PUNCH 7000,(I,LCONST(I),I=1,NI)
7000 FORMAT(15M *HWS *ROW,I3,I12)
DO 11 J=1,NJ
  PUNCH 8000,J,LZMIN(J)
8000 FORMAT(7M *Y,I5,6HZMIN ,I12)
PUNCH 9000,(J,I,MATRIX(I,J),I=1,NI)
9000 FORMAT(7M *Y,I5,3HROW,I3,I12)
11 CONTINUE
IF(I=DATA.EQ.1) GO TO 12
CALL EXIT
END

```



Figure 3. Sample Listings

APPENDIX J

OFF-ROAD AND PRIMITIVE-ROAD MOBILITY: ROAD/VEHICLE FACTORS

It is required that intelligence and reconnaissance personnel have the means for determining the capacity of various types of terrain to support specific vehicles. The ability of terrain to support repeat passes of vehicles is referred to as soil trafficability. Trafficability predictions can be made from a study of the topography, the types of soils, and the weather data. Soils most difficult to traverse are generally fine grain soils and those sands that contain enough fine grain soils to make them behave like fine grain soils when wet. Coarse grain soils on the other hand generally provide good support for repeated traffic. Means are currently available for measuring trafficability by tests of the soil both with a cone penetrometer and a soil sampler and remolding equipment. Also it is reasonable to predict mobility of both flat and sloping terrains and to plot trafficability data on maps or aerial photographs.

To do this it is necessary to have a knowledge of topography, soil types and weather conditions in the area of interest. To provide a complete picture it is also necessary to consider natural or man made obstacles such as forests or ditches and to give consideration to vehicle characteristics or the ability of a vehicle to operate under off-road conditions. This report is limited to discussions in temperate climates or in climates where the soil is not frozen at the time of passage of traffic.

CONE INDEX

The cone index is the measure of shearing resistance of soil obtained with an instrument called a cone penetrometer. The numerical value is actually the load which the soil will resist as measured in pounds per square inches. The characteristics of soil changes as a function of repeated traffic. This change is referred to as remolding. Remolding may have a beneficial, a neutral, or a detrimental effect resulting in a change of soil strength. This change in the soil strength as a ratio to its original strength is referred to as a remolding index. The rating cone index of the soil is the measured cone index multiplied by the remolding index. This value expresses the soil strength rating of the point subjected to sustained traffic. For example, if a soil has a cone index of 120 and the remolding index of 0.60 at its critical layer, its strength may be expected to fall by the value of 120×0.60 or to a value of 72 under traffic. Accordingly,

such a soil is not trafficable for vehicles with a vehicle cone index greater than 72.

The vehicle cone index is a numerical value assigned to a given vehicle that indicates the minimum soil strength in terms of rating cone index required for from 40 to 50 passes of the vehicle.

The operation of vehicles in wet fine grain soil sometimes can be hampered seriously by stickiness. Under extreme conditions, sticky soil can accumulate in the running gear of a vehicle to the point where travel and steering is difficult. This is usually associated with soils of low bearing capacity. The presence of water or a layer of soft fluid mud overlaying a firm layer of soil can produce a slippery surface which can make the steering of vehicles very difficult and can immobilize rubber-tired vehicles. This condition can be experienced even with soils of high bearing capacity.

Weather changes will produce very marked changes in the ability of a soil to support traffic. During rainy periods when moisture is added to fine grain soils the resultant is increased slipperiness and stickiness and decreased strength. Dry periods have opposite effects. Loose sands on the other hand actually improve in trafficability through an increase in cohesion as a result of moisture added in rainy periods. When dry, they return to the loose, less trafficable state. Trafficability characteristics measured on a given data cannot be applied later unless full allowance is made for the changes in soil strength caused by weather. In many cases this must be a judgement factor.

In those cases in which reconnaissance teams can enter an area to make measurements, data can be obtained to permit determination of the number and type of vehicles that can cross the area, the loads they can carry or tow and the slopes they can climb. Measurements are only valid for the time of the measurements and short periods thereafter provided no rain occurs.

The range of cone indexes where most vehicles can travel is between 30 and 200. Only the most mobile of military vehicles such as the M29 Weasel, the M76 Otter and certain Canadian snow vehicles can travel on soils with a cone index as low as 30, and only a few special vehicle-require cone indexes over 200. It is possible to gather data for trafficability and to class large

areas as above or below the critical range without extensive testing.

When the RCI, rating cone index, for a given area is equal to or higher than the vehicle cone index of the using vehicle, sufficient strength will be available in the soil to withstand the passage of from 40 to 50 of this vehicle or vehicles with smaller vehicle cone indexes, operating at slow speeds in the same ruts. It will also permit stopping and resumption of movement. A larger number of vehicles can be moved through the area if space is available parallel to the track to permit spreading of traffic. The strength will also be sufficient to permit a vehicle to enter the area, stop, back out of the ruts while turning and retreat from the area.

It is difficult to establish strength criteria for a one pass operation. Most soils are not homogeneous and they vary over a greater range than the strength represented by the difference between a soil condition which will not permit one pass and a condition which will permit only one pass. A rating cone index equal to 75% of the vehicle cone index usually will be adequate to permit one or two straight line passes of the vehicle.

The ability of 50 given vehicles to travel in straight line formation over a level area is assured if the rating cone index of the area is greater than the vehicle cone index. There is danger of immobilization before 50 vehicles have passed if the rating cone index is below the vehicle cone index. Immobilization will occur early if the rating cone index is well below the vehicle cone index. Free water on the surface or the presence of low strength material with a firmer material immediately below indicates danger of immobilization of wheeled vehicles because of slipperiness.

A vehicle towing a load must overcome not only its own rolling resistance but that of the towed vehicle as well. Since additional shear strength is required to produce the necessary thrust, a tow load applied to a vehicle increases the cone index requirements. Performance curves for towed vehicles on level terrain are available wherein rating cone index is correlated with required towing force as a percentage of vehicle gross weight for various types and weights of vehicles. Given the vehicle and the rating cone index the force required to tow the vehicle on level terrain can be determined.

Performance curves are also available wherein the rating cone index is related to the maximum towing force that the vehicle can apply on level terrain as a percentage of its gross weight and to the maximum slope the vehicle can negotiate with no tow load. If the rating cone index is expressed as the value over and above that required for operation on level ground without a tow load, all vehicles can be grouped into three types: A, wheeled vehicles; B, track vehicles, with grousers less than $1\frac{1}{2}$ inches long; and C, track

vehicles with grousers more than $1\frac{1}{2}$ inches long. The cone index over and above that required for operation on level ground is equal to the rating cone index minus the vehicle cone index. Given the vehicle and the required towing force, the necessary rating cone index can be determined. Also given the vehicle and the rating cone index the maximum slope negotiable can be determined.

The maximum slope a vehicle towing another can negotiate can be determined from the formula $T_1 - T_2$ divided by W_1 plus W_2 where T_1 is the maximum tractive power available to the towing vehicle (in pounds), T_2 is the towing force (in pounds) required on level ground and W_1 and W_2 are the weights (in pounds) of the towing and towed vehicles. The above mentioned method can be used for determining the value of T_1 and T_2 for non-slippery surfaces.

VEHICLE CLASSIFICATION

Vehicles can generally be divided into four classes: A, self-propelled track vehicles; B, self-propelled wheeled vehicle; C, towed track vehicles; and D, towed wheeled vehicles. In addition there can be a sub-heading of each of the above types for amphibious vehicles. Vehicles can also be divided into seven arbitrary categories according to cone index requirements. The range of cone index for each category and an indication of the type of vehicle which falls under each category follows: Category 1, cone index range 20 to 29; This category includes vehicles such as the M-29 Weasel, the M 76 Otter, and the Canadian Snowmobile.

Category 2, cone index range 30 to 49; This category includes high speed tractors with comparatively wide tracks and low contact pressures.

Category 3, snow index range 50 to 59; This category includes tractors with average contact pressures, tanks with comparatively low contact pressures and some trailed vehicles with very low contact pressures.

Category 4, cone index range 60 to 69; This category includes most medium tanks, tractors with high contact pressure and all-wheel-drive trucks and trailed vehicles with low contact pressures.

Category 5, cone index range 70 through 79; This includes most all-wheel-drive trucks, a great number of trailed vehicles and heavy tanks.

Category 6, cone index range 80 to 89; This includes a great number of all-wheel-drive and rear-wheel-drive trucks and trailed vehicles intended primarily for highway use.

Category 7, cone index range 100 or greater; This includes rear-wheel-drive vehicles and others that are generally not expected to operate off roads,

especially in wet soils. Some examples of vehicles are given in Table 1.

The mobility index is a number obtained by applying certain characteristics of the vehicle to empirical equations which have been developed. The mobility index has been correlated with the minimum cone index requirements for a range of military vehicles of all classes. For conventional type vehicles the equations can be used to compute the mobility index.

TRAFFICABILITY FACTORS

A method has been developed for mapping measured trafficability factors. Since vehicle cone indexes vary widely it is desirable to present the basic terrain data in such form that direct comparison with vehicle cone indexes can be made. The four basic factors in describing soil trafficability are; soil type, rating cone index, slope, and slipperiness. As an overlay on a map, the soil type may be shown by a letter symbol, the cone index by a single value, slope by a number indicating grade in percent, and slipperiness by a letter. Stickiness effects are not generally serious enough to include on maps. By looking at a map so designated it can be determined the type of vehicle suitable for operation through that area under the given conditions. If the maps indicate marginal conditions for the vehicles available some improvement in vehicle mobility can be obtained such as by fitting tire chains on trucks for movement through these terrains. Other data such as vegetation, drainage, and cultural features and the topography must be considered in conjunction with soil trafficability.

Soil trafficability analysis can sometimes be made in advance of a proposed operation without contact with the area. An estimate of trafficability can be made if something is known of the general weather conditions, soils and topography of the area. Information about weather and climate usually is available even for remote areas from meteorological records, climatology textbooks or interrogation of prisoners. When feasible, air weather service should be contacted for weather and climate data. Soils and topography data may be obtained from topographic maps, soil maps, geologic maps, aerial photographs, or interrogation. The accuracy of an estimate will depend upon the type, quantity and accuracy of the data available. It also will depend largely upon the ability of the analyst to interpret these data, especially if soil types must be deduced from geologic maps or aerial photographs.

Two general conditions of weather as it applies to soil trafficability estimates must be considered. These conditions are the dry period and the wet period. A dry period is defined as a time when climatic vegetal factors combine to

produce soil moistures that are generally low. A wet period is one in which the combination of pertinent factors serves to produce soil moistures that are generally high. During a dry period soils will be passable unless they are low lying and poorly drained or wet by underground springs or there is a high water table for any other reason. During this period one fine grain soil, or sand with grains poorly drained, has little advantage over another as far as strength is concerned. Sand in a dry state is less trafficable than in a wetter condition, with exception of quick sands. In general, dry sands are of a poorer trafficability than a dry fine grain soil and sands with fines poorly drained.

Moisture added to a soil causes changes in its strength. Different soils are effected differently by moisture. During a wet period, soils, with the exception of clean sands and gravels, should be suspected of poor trafficability.

SOIL CHARACTERISTICS

Soils may be divided into four general groups from the standpoint of their trafficability during a wet period and rated in the following decreasing order: A, B, C, and D. The soils within each group are listed in approximate order of trafficability. The letter symbols are the same as employed in the Unified Soil Classification System. Group A: This includes soils well graded (GW); poorly graded gravels (GP); well graded sands (SW); and poorly graded sands (SP). Group B: Inorganic clays of high plasticity, fat clays (CH). Group C: Clayey gravels (GC); clayey sands (SC), and CL soils (gravelly clays, sandy clays, inorganic clays of low to medium plasticity, lean clays, and silty clays).

Group D: Silty gravels (GM), silty sands (SM), ML and CL-ML soils (inorganic silts and very fine sands, rock flour, silty or clayey fine sands or clayey silts with slight plasticity), H soils (inorganic silts, micaceous, or diatomaceous fine sandy or silty soils and elastic silts), OL soils (organic silts and organic silty clay of low plasticity), and OH soils (organic clays of medium to high plasticity and organic silts).

Peat, muck, swamp soils and so on are practically always impassable for all except light amphibious type vehicles.

Table 2 shows for the four soil groups above the soils included in each estimate of cone index, remolding index, rating cone index, and slipperiness and stickiness effects and general comments on trafficability for the wet season.

Table 1. Examples of Vehicles and Characteristics.

Nomenclature	VCI	Purpose	Weight (Pounds)		Maximum Allowable Speed (MPH)	Cruising Range (Miles)	Fuel Capacity and Type (Gal)	Water Crossing Capability (Inches)		Air Transportability	
			Net	Payload (Highway)				W/Kit	W/O Kit	Phase	Type
1/4-ton M38A1	50	Utility	2,665	1,200	55	280	17 gas	70	37.5	1	C-130A
1/4-ton M151B1		Utility	2,273	1,200	60	300	17.7 gas	60	21	1	C-130A
1/4-ton M170		Ambulance	2,963	1,200	not governed	300	20 gas	70	15	1	C-130A
3/4-ton M143	60	Ambulance	7,150	1,400	55	225	25 gas	84	42	1	C-130A
3/4-ton M37B1	60	Cargo Truck	5,700	2,000	55	225	24 gas	84	42	1	C-130A
1/2-ton M274	32	Carrier, Lt. Weapons	795	1,000	25	107.5	8 gas	N/A	18	1	C-130A
2-1/2-ton M135	62	Cargo Truck	12,330	10,000	58	350	56 gas	78	30	1	C-130A
2-1/2-ton M34	64	Cargo Truck	11,775	10,350	58	350	50 gas	72	30	1	C-130A
2-1/2-ton M35	69	Cargo Truck	12,405	10,350	58	300	50 gas	72	30	1	C-130A
2-1/2-ton M36		Cargo Truck	14,230	10,000	58	300	50 gas	72	30	1	C-130A
2-1/2-ton M211	68	Cargo Truck	13,170	10,000	55	300	56 gas	78	30	1	C-130A
2-1/2-ton M49C	48	Tanker gas with segregator kit	13,955	3,000 (1,200 gal.)	58	350	50 gas	72	40	1	C-130A
2-1/2-ton M217		Fuel servicer w/ segregator kit	14,805	6,000 (1,200 gal.)	55	300	56 gas	80	30	1	C-130A
2-1/2-ton M50		Tanker, water	15,038	8,500 (1,000 gal.)	58	350	50 gas	72	40	1	C-130A
2-1/2-ton M222		Tanker, water	14,100	8,500 (1,000 gal.)	55	300	56 gas	80	30	1	C-130A
2-1/2-ton M221		Truck tractor	11,695	12,000	55	300	56 gas	72	30	1	C-130A
2-1/2-ton M275		Truck tractor	11,179	12,000	58	350	50 gas	72	30	1	C-130A
2-1/2-ton M		Shop van	15,231	5,350	35-50	350	50 gas	72	30	111	C-124A
2-1/2-ton M220		Shop van	15,085	7,500	55	300	56 gas	80	30	111	C-124A
2-1/2-ton M108		Wrecker, crane	19,785	3,850	67	350	50 gas	72	40	1	C-130A
2-1/2-ton M60		Wrecker, light	23,960	3,500	60	300	50 gas	72	40	1	C-130A
2-1/2-ton M35A1		Cargo Truck	13,443	10,000	58	350	50 gas diesel or kerosene	N/A	30	1	C-130A
2-1/2-ton M135		Searchlight set	12,330	6,695	58	350	56 gas	73	30	1	C-130A
		Expandable bulky equip.	20,609	5,000	58	300	50 gas	72	40	111	C-133A
5-ton M41	70	Cargo Truck	19,119	15,000	59	280	78 gas	78	30	1	C-130A
5-ton M54		Cargo Truck	19,580	20,350	52.6	214	78 gas	78	30	1	C-130A
5-ton M55		Cargo Truck	24,064	20,000	52.6	214	78 gas	78	30	1	C-130A
5-ton M52		Truck tractor	18,813	25,000	52	300	78 gas	78	30	111	C-124A
5-ton M246		Tractor wrecker	32,830 w/winch	16,000	52	229	78 gas	78	30	111	C-124A
5-ton M62	68	Wrecker	33,675	12,000	52.6	214	78 gas	78	30	111	C-124A
5-ton M543		Wrecker	34,440	12,000	52.6	217	78 gas	78	30	111	C-124A
10-ton M125		Cargo Truck	30,000	30,000	42	330	166 gas	73	30	111	C-124A

Table 1. (Cont'd)

Wheeled Vehicles										
10-ton M123		32,250	35,000	42	300	166 gas	78	30	111	C-124A
M250	Tractor Gunlifting truck, Hv.	35,910	45,330	30	165	140 gas	N/A	60	111	C-133A
M)	Gunlifting truck, Hv.	37,950	51,675	30	165	140 gas	N/A	60	111	C-133A
1/2-Ton M274 mule XM523-E2 HET	Lt. Weapons Carrier Hv. Equip Transporter	800 36,500 31,800	1,000 110,000	25 30	100 ---	---- Diesel	-- 80	18 40	1 111	CV-2 C-133A

Armored Personnel, Cargo and Equipment Carriers											
M59	41	Armored Per- sonnel Carrier	39,504	3,096	32	120	136.5 gas	Amphib	N/A	111	C-133A
M106		Armored Mor- tar Carrier	22,510	3,220	40	200	80 gas	Amphib	N/A	1	C-130A
M113	47	Armored Per- sonnel Carrier	20,310	3,860	40	200	80 gas	Amphib	N/A	1	C-130A
M116E1		Cargo carrier	7,880	3,000	40	200-300	65 gas	Amphib	N/A	1	C-130A
M577		Command Post	19,600	4,300	40	200	160 gas	Amphib	N/A	111	C-124A

Some Developmental Surface Vehicles											
1-1/4-ton Gamma Goat	34	Cargo Transport	3,900	2,900	53	Unk	Unk. Die.	Amphib		1	C-130A
2-1/2-ton XM410	33	Cargo truck	9,000	5,000	55	Unk	Unk. Die.	Floatable		1	C-130A
5-ton XM656		Cargo truck	15,415	10,400	50	350	gas, diesel kerocene	Amphib	30	111	C-130A
8-ton Goer. XM520E1	72	Cargo Truck	20,190	16,400	30	400	80 diesel	Amphib		111	C-133A
8-ton Goer. XM559		tank. (2500 gal)	Unk.	Unk.	31	400	80 diesel	Amphib		111	C-133A
10-ton Goer. XM553		Wrecker	39,725	8,500	30	400	80 diesel	Amphib		111	C-133A
20-ton Goer. XM554		Wrecker	57,140	8,800	32.5	300	160 diesel	Amphib		111	C-133A
16-ton Goer. XM437E1	79	Cargo Truck	39,60	32,000	31	300	170 diesel	Amphib		111	C-133A
16-ton Goer. XM438E2	80	Tanker. Fuel	38,670	32,000	31	300	170 diesel	Amphib		111	C-133A
M113E2		Armed Person- nel Carrier	19,755	2,260	40	300	Unk. Die.	Amphib		1	C-130A
XM518	44	Cargo Tractor	12,080	11,920	40	300	Unk. Die.	Amphib		Unk.	Unk.
XM491		Ammo/Cargo	32,000	32,000	35	500	320 diesel	Unk.	42	111	C-124A
Univ. Engr. Tracked Armed		Excavation	28,000	16,200	32	Unk.	97 diesel	Amphib		1	C-130A
XM571	27	Pers. Carrier	4,870	2,400	30	Unk.	Unk. gas	Amphib		1	CV-2B
XM546		Guid. Msl. Equip Carrier Mauler	Unk.	Unk.	Unk.	Unk.	Unk. gas	Amphib		1	C-130A
XM1548 Mod		Guided Msl. Equip. Carrier	Unk.	Unk.	Unk.	Unk.	Unk. gas	Amphib		1	C-130A

Table 2. Trafficability Characteristics of Soils in Wet Season

Group	Soils	Unified Soil Classification System					Probable Remolding Index Range	Probable Rating Cone Index Range	Slipperiness Effects	Stickiness Effects	Remarks
		Soils	Probable Cone Index Range	Probable Remolding Index Range	Probable Rating Cone Index Range	Slipperiness Effects					
A	Coarse-grained cohesionless and gravels	GW, GP, SW, SP	80-300	1	80-300	1	80-300	None to Slight	None	Will support continuous wheeled traffic with low pressure tires. Moist sands good, dry sands fair.	
B	Inorganic clays of high plasticity, fat clays	CH	55-165	0.75 to 1.35	55-165	0.75 to 1.35	65-140	Slight to Severe	Slight to Severe	Will usually support more than 50 cycles of wheeled vehicles. Traction may be difficult at times.	
C	Clayey gravels, gravel-sand-clay mixtures, clayey sands, sand-clay mixtures, gravelley clays, sandy clays, inorganic clays of low to medium plasticity, lean clays, silty clays	GC, SC, CI	85-175	0.45 to 0.75	85-175	0.45 to 0.75	45-125	Slight to Severe	Slight to Moderate	Will usually support limited traffic of wheeled vehicles. Traction will be difficult in most cases.	
D	Silty gravels, gravel-sand-silt mixtures, silty sands, sand-silt mixtures, inorganic silts and very fine sands, rock flour, silty or clayey fine sands or clayey silts with slight plasticity, inorganic silts, micaceous or diatomaceous fine sandy or silty soils, elastic silts, organic silts and organic silty clays of low plasticity, organic clays of medium to high plasticity.	GM, SM, ML and CL-ML, MH, OL, OH	85-180	0.25 to 0.85	85-180	0.25 to 0.85	25-120	Slight to Moderate	Slight	Will usually not support more than a single pass. Traction will be difficult in most cases.	

From "Soil Classification", Technical Memo 3-240, 11th Supplement, Waterways Experiment Station, August 1954

Table 3. Approximate Range of k-values for Soil Groups of the Casagrande Soils Classification as Used by Corps of Engineers, Department of the Army

Major divisions	Soil groups and typical description	Subgrade group symbols	Approximate range of k-values for each soil group
Gravel and gravelly soils	Well-graded gravel and gravel-sand mixtures. Little or no fines.	GW	500-700 or greater
	Well-graded gravel-sand-clay mixtures. Excellent binder.	GC	400-700 or greater
	Poorly graded gravel and gravel-sand mixtures. Little or no fines.	GP	300-500
	Gravel with fines, very silty gravel, clayey gravel, poorly graded gravel-sand-clay mixtures.	GF	250-500
Sands and sandy soils	Well-graded sands and gravelly sands. Little or no fines.	SW	250-575
	Well-graded sand-clay mixtures. Excellent binder.	SC	250-575
	Poorly graded sands. Little or no fines.	SP	200-325
	Sand with fines, very silty sands, clayey sands, poorly graded sand-clay mixtures.	SF	175-325
Fine-grained soils having low to medium compressibility	Silts (inorganic) and very fine sands, no, rock flour, silty or clayey fine sands with slight plasticity.	ML	150-300
	Clays (inorganic) of low to medium plasticity, sandy clays, silty clays, lean clays.	CL	125-225
	Organic silts and organic silt-clays of low plasticity.	OL	100-175
Fine-grained soils having high compressibility	Micaceous or diatomaceous fine sandy and silty soils, elastic silts.	MH	50-175
	Clays (inorganic) of high plasticity, fat clays.	CH	50-150
	Organic clays of medium to high plasticity.	OH	50-125

LEGEND for group symbols

G - gravel
 S - sand
 M - no, very fine sand, silt, rock flour
 C - clay
 F - fines, material smaller than 0.1-mm. diameter

O - organic
 W - well-graded
 P - poorly graded
 L - low to medium compressibility
 H - high compressibility

From "Concrete Pavement Design", Portland Cement Association, 1951

TERRAIN FEATURES

The effects of slopes on soil requirements for vehicle performance can be shown in quantitative units when measurements of cone index can be made, but in estimates of trafficability only general statements concerning slopes are feasible. Slopes require better soil conditions for vehicle support than do similar level terrain. Slopes of about 45% on fine grain soils and sands with fines poorly drained and about 30% on sands (at very low tire pressures) are the greatest that should be attempted in dry seasons, and 30% slopes are the maximum that should be tried in the wet season. Ridges will generally be more trafficable than adjacent valleys. Downhill travel is easier than up hill travel.

Maps which delineate surface soils according to their Unified Soil Classification can be used readily to make estimates of trafficability. Maps of this type are scarce and the more common types of soil maps are those employing an agricultural system of soil classification. These agricultural maps must first be translated into engineering terms before a soil trafficability estimate can be made. No exact method exists for doing this but analysts familiar with the two systems of classification can usually make good comparisons. The term loam used extensively in agricultural systems usually includes soil in the classes CL and ML.

Soils are formed by the action of five factors: Parent material, climate, age, topography and vegetation. Given a geologic map for parent

material and age data and the general knowledge of the other three factors, trained analysts can estimate the soil types most likely to occur in the area.

The full utilization of aerial photographs in estimating trafficability is presently being studied. Air photos are a good source of topographic information. Estimates of elevation and slopes can be made from stereo-pairs. Accurate elevation and slopes can be obtained by trained operators using mechanical devices such as multiplex equipment. Aerial photographs also are an excellent means of identifying such obstacles as rivers, forests, escarpments, embankments and so on.

In the present stage of development the techniques for identifying soils from air photos are so complex that only well trained technicians can employ them to their fullest extent. However, certain general facts can be used to advantage by personnel with a minimum of training. For instance orchards generally are planted in well drained soils, vertical cuts are usually evidence of deep loessial, silty soils; tile drains in agricultural areas indicate the presence of poorly drained soils, probably silt and clays. On a given photograph, light color tones generally signify a higher elevation, sandier soils, and lower moisture content than do dark color tones. The same color tone may not signify the same conditions throughout the same photo and may have entirely different significance on two separate photographs. Natural tones are apt to be obscured and modified by tones created by vegetation, both natural and cultivated, by plowed fields and by shadows of clouds.

APPENDIX K

VEHICLE - TERRAIN EXAMPLE:

A VELOCITY FIELD ASSIGNMENT CRITERION

The transit time associated with any link in a transportation network can be given by:

$$t_i = \int_{l_i} \frac{dl}{V_i(l)}$$

where l_i is the physical length of the link in kilometers, and V_i is the velocity of a given vehicle over the link. To a first approximation, we can consider only a discrete set of velocities, and then

$$t_i = \sum_j \frac{l_{ij}}{V_{ij}}$$

where the V_{ij} are the various velocities for different segments of the link.

We give here an example of the quantitative values one could assign to velocities corresponding to various vehicle and road descriptors. For instance, we can introduce the notation

$$V_{ij} = V(\alpha\beta; a b c d e f)$$

where the Greek letters indicate vehicle characteristics and the Latin letters road characteristics; the number of variables selected is, of course, somewhat arbitrary. We take the values as follows:

- $\alpha = 1$, automotive
- $\alpha = 2$, water transport
- $\alpha = 3$, air
- $\alpha = 4$, foot

We consider examples of each in turn.

1. **Automotive:** $\alpha = 1$, i.e., $V = V(1\beta; a b c d e f)$ is to be taken as an integer designating the type of vehicle; specifically it should give some indication of the vehicle's mobility rank, e.g., its vehicle cone index.

The possible values of a, b, c, d, e, and f are taken to correspond to road data as follows:

- a: terrain
 - a = 1, mountainous
 - a = 2, hilly
 - a = 3, flat or rolling

- b: road width
 - b = 1, narrow
 - b = 2, wide
- c: surface type
 - c = 1, natural (dirt)
 - c = 2, metalled (gravel, laterite, etc.)
 - c = 3, waterproof (concrete, asphalt)
- d: maintenance (condition)
 - d = 1, poor
 - d = 2, fair
 - d = 3, good
- e: moisture and atmospheric factors
 - e = 1, thick mud
 - e = 2, occasional mud
 - e = 3, heavy dust (or hard rain - poor visibility)
 - e = 4, light dust
- f: time of day
 - f = 1, night
 - f = 2, day

If we take $\beta = 1$ to correspond to a 2-1/2 ton truck, we can get values for the matrix $V(11; a b c d e f)$ from studies on traffic tests in Thailand. Tables 1-4 shows the values in kilometers/hour for the measured average speeds (multiplied by 0.8 to compensate for the lack of convoy integrity in the tests). (Note that no appreciable day-night difference is noted, and that heavy mud speeds are only inferred.)

For general road use, at least one more column (e-value) is needed:

- e = 0, impassable

To convert the 2-1/2 ton truck figures to other vehicles (for given road conditions), the following simple criterion may be used as a first approximation for the two critical categories:

- e = 0, impassable and
- e = 1, heavy mud (but passable)

If the vehicle cone index is greater than the rating cone index of the road,

$$VCI > RCI$$

then

$$e = 0$$

On the other hand, if

$$VCI < RC!$$

then

$$e = 1$$

For off-road conditions, we need the additional surface type

$$c = 0, \text{ off-road}$$

Data on off-road mobility (not shown in the tables) can be used to differentiate $e = 0$ conditions from $e = 1$ conditions, just as in the $c = 1$ (dirt road) example.

To further convert the 2-1/2 ton table to other vehicles, one needs roughly just the condition

$$V(1\beta; a b c d e f) = \text{Min}\{V(11; a b c d e f), V_{\text{Max}}(1\beta; a b c d e f)\}$$

where the maximum velocity of the vehicle " β " is indicated.

2. Water Transport: $\alpha = 2$. $V = V(2\beta; a b c d e f)$

Here the variable β can be used to describe the speed of the boat in still waters and the variable a , for example, can be defined to be the speed of the stream; b could be the direction of travel (upstream or downstream); c could indicate stream size; e could indicate moisture conditions (as before), and so on. For example, for descending the Mekong in September, we might assign

- $a = 6$, stream speed 6 Km/hr.
- $b = 2$, downstream
- $c = 3$, large
- $e = 1$, rainy, flooded

and if $\beta = 2$ corresponds to a sampan (still-water velocity 7 Km/hr.), we would have $V(22; 6 2 3 d 1 f) = 6 + 7 = 13$ Km/hr.

while for

$$b = 1, \text{ upstream}$$

$$V(22; 8 1 3 d 1 f) = -6 + 7 = 1 \text{ Km/hr.}$$

Other matrix elements can be assigned similarly.

3. Air: $\alpha = 3$. $V = V(3\beta; a b c d e f)$

Examples are

$$\beta = 1, \text{ helicopter,}$$

where, with the usual values of e and f ($e \sim$ weather, $f \sim$ time-of-day), we might have:

$e \setminus f$	1	2	$V(3 1; a b c d e f)$
1	0	0	
2	0	0	Km/hr.
3	160	160	
4	160	160	

where the effects of bad weather are shown, while for

$$\beta = 2, \text{ airplane,}$$

the effects of operating from a commercial unlighted airport would give the following pattern:

$e \setminus f$	1	2	
1	0	0	
2	0	0	$V(32; a b c d e f)$
3	0	650	
4	0	650	

where the impossibility of night and/or bad-weather operation is displayed.

Of course, actual velocities will be immensely more complicated in their dependence on the various descriptors; the tables above are only intended to be illustrative of methods of treating first-order effects.

4. Foot: $\alpha = 4$. $V = V(4\beta; a b c d e f)$

The final stage of a transport problem may involve pedestrian movement. This possibility can be included by letting $a b c d e f$ have their $\alpha = 1$ meanings. Then we might have matrices such as

$a \setminus c$	0	1	2	3	
1	1	2	2	4	
2	2	3	4	4	$V(4\beta; a b c d e f)$
3	3	4	5	5	Km/hr.
3	3	4	5	5	

where the effects of terrain (a) and road surface (c) are displayed.

Table 1. $V(11; a 1 c d e f)$, km/hr.

Narrow - All Terrains.					
Condition (d) vs. Moisture (e)					
	(Heavy) Mud	(Light) Mud	(Heavy) Mud	(Light) Mud	
$d \setminus e$	1	2	3	4	
(poor) 1	10	10	12	12	$c=1$ (dirt)
(fair) 2	10	12	15	-	
(good) 3	10	12	15	15	
$d \setminus e$	1	2	3	4	
1	10	12	15	17	$c=2$ 20 (metalled)
2	10	12	15	20	
3	10	12	15	20	
$d \setminus e$	1	2	3	4	
1	20	20	20	20	$c=3$ 25 (water-proof)
2	25	25	25	25	
3	25	25	25	25	

Table 2. V(11; 3 2 c d e f), km/hr.

Table 3. V (11; 2 2 c d e f), km/hr.

Wide - Flat. Condition (d) vs. Moisture (e)*					Wide-Hilly. Condition (d) vs. Moisture (e)*						
d\^e	1	10	10	12	12	d\^e	1	10	10	12	12
	2	10	15	15	19		2	10	15	15	19
	3	10	19	15	24		3	10	19	15	24
d\^e	1	10	14	15	17	d\^e	1	10	14	15	17
	2	10	26	15	33		2	10	23	15	29
	3	10	29	15	36		3	10	23	15	29
d\^e	1	20	20	20	20	d\^e	1	20	20	20	20
	2	37	37	37	37		2	29	29	29	29
	3	48	48	48	48		3	29	29	29	29

Table 4. V (11; 1 2 c d e f), km/hr.

Wide-Mountainous. Condition (d) vs. Moisture (e)*					
d\^e	1	10	10	12	12
	2	10	15	15	19
	3	10	19	15	24
d\^e	1	10	14	15	17
	2	10	19	15	24
	3	10	19	15	24
d\^e	1	20	20	20	20
	2	24	24	24	24
	3	24	24	24	24

*See Table 1 for meaning of indices.

APPENDIX L

NOMENCLATURE

<u>Allocation Schedule</u>	A shipping schedule of resources from a given set of specified locales to another set of specified locales
<u>Alternate Segment</u>	Any segment of the transportation link not along the primary route.
<u>Elemental Area</u>	Any two locales with an interconnecting transportation system.
<u>Loading Efficiency</u>	Efficiency factor representing the capability of a locale to transfer cargo between two vehicles.
<u>Locale</u>	Any logical subdivision of the region which may be assigned a unique set of military, economic, and cultural resources and requirements. Possible locales are nodes, hamlets, cities or larger areas containing one or more hamlets or cities. Geographically represented as a point, when the system is simulated.
<u>Minimum Time Route</u>	The transportation route between two locales which a given vehicle can traverse in minimum time.
<u>Network</u>	Combination of locales and transportation systems.
<u>Node</u>	A particular geographical location served by a transportation system.
<u>Path</u>	A trajectory or route between two nodes.
<u>P-Capacity</u>	Maximum road capacity of a vehicle over a transportation link determined by the segment characteristics.
<u>Primary Route</u>	Main transportation route between two locales. This route may pass through intermediate locales.
<u>Primary Segment</u>	Any segment of the main transportation route.
<u>Region</u>	Total territorial area under consideration.
<u>Resources Reallocation</u>	A redistribution of resources among those locales designated as centers of resource.
<u>Segment</u>	Any continuous portion of a path having a uniform terrain classification and which has nodes only at its end points.
<u>Specified Route</u>	A transportation route between two locales consisting of user specified segments.
<u>Terrain Type</u>	Code number specifying physical features of a segment.
<u>Time Marks</u>	Marks representing distances along each segment from a given locale that a specified vehicle can reach in a given time.
<u>Transfer Times</u>	Average time required to transfer cargo between two specified vehicles.
<u>Transportation Network</u>	A set of nodes with their interconnecting usable paths.

APPENDIX L

NOMENCLATURE
(cont)

<u>Transportation Route</u>	Any combination of segments connecting two locales.
<u>Tree</u>	Collection of minimum time routes.
<u>Vehicle Mobility Map</u>	Map showing all segments of a transportation system traversible by a specified vehicle.
<u>Vehicle Factor</u>	Number representing the probability of a vehicle successfully traversing the segment.
<u>W-Capacity</u>	Ratio of vehicle width to segment width.

APPENDIX M

REFERENCES

- Agarwala, A. N. and Singh, S. P. ed., The Economics of Underdevelopment, Oxford University Press, New York, 1963.
- Bartee, T. C., Lebow, I. L., and Reed, I. S., Theory and Design of Digital Machines, McGraw-Hill Book Company, Inc., New York, 1962.
- Bellman, R., Dynamic Programming, Princeton University Press, Princeton, N. Y., 1957.
- Carr, C. R. and Howe, C. W., Quantitative Decision Procedures in Management and Economics, McGraw-Hill, New York, 1964.
- Control Data Corporation, "User's Manual for Integer Linear Programming ILP-2", (Data Centers Division, Applications Program # 15), Minneapolis, 1965.
- Cornell Aeronautical Laboratory, Inc., "Survey and Program Definition for Off-Road Mobility Research", (Technical Report CAL No. VJ-2330-G-1), Cornell University, Buffalo, New York, March 1967.
- Cornell Aeronautical Lab., Inc. "Off-Road Mobility Research", (Technical Report CA No. VJ-2330-G-1), Cornell University, Buffalo, N. Y. September 1967.
- De Long, M. M. and Goss, D. N., "A Feasibility Study of a Remote Area Land Transportation Concept", RACIC-TR-59, Battelle Memorial Institute, Columbus, Ohio, 1967.
- Hall, Anthony T., "'Mudlark': Tests of the FV 432 Stalwart, M113 $\frac{1}{2}$, M551 and FV 437 in Thailand," Joint Thai - U. S. Military Research and Development Center, Bangkok, Thailand, 1967.
- McCluskey, E. J., Jr., Introduction to the Theory of Switching Circuits, McGraw-Hill Book Company, Inc., 1965.
- Philco-Ford Corporation, Provincial Handbook Changwat Nakhon Phanom, Thailand, (Techrep Division), 1967.
- Transportation Consultants, Inc., "A Comprehensive Evaluation of Thailand's Transportation System Requirements", Washington, 1959.

DOCUMENT CONTROL DATA - R & D

(Security classification of title, body of abstract and indexing annotation must be entered when the overall report is classified)

1. ORIGINATING ACTIVITY (Corporate author) Systems Associates Inc. Long Beach, Calif	2a. REPORT SECURITY CLASSIFICATION
	2b. GROUP

3. REPORT TITLE
Developing Area Transportation Study
Program Formulation

4. DESCRIPTIVE NOTES (Type of report and inclusive dates)
Conceptual Phase May 1967 - February 10 1968

5. AUTHOR(S) (First name, middle initial, last name)
Seymour Lampert William Ramsey Charles Walli

6. REPORT DATE February 1968	7a. TOTAL NO. OF PAGES 139	7b. NO. OF REFS 15
---------------------------------	-------------------------------	-----------------------

8a. CONTRACT OR GRANT NO. D.A.H C04-67-C-0063 b. PROJECT NO. ARPA Order No. 1027 dated 24 May 1967 c. d.	9a. ORIGINATOR'S REPORT NUMBER(S) SAI - R 10062
	9b. OTHER REPORT NO(S) (Any other numbers that may be assigned this report)

10. DISTRIBUTION STATEMENT

11. SUPPLEMENTARY NOTES Monitoring Agency U. S. Army Research Office, Durham	12. SPONSORING MILITARY ACTIVITY ARPA Project AGILE
--	--

13. ABSTRACT

The objective of this program is to develop the process for formulating the plan for a Developing Area Transportation System (DATS). This plan must account for those factors involving the security of a particular region and their interaction with those associated with its uniform socioeconomic growth.

The process described in this report is the initial phase of a four-phase program. It is concerned with the synthesis of a transportation system that may be used for determining the adaptability of various systems options involving socioeconomic and security factors as they relate to the developing area requirements.

A simulation program SIMDATS has been devised which represents the system under consideration. This simulation may be used in part or in total for validating a particular approach by simulating conditions in an actual region. Such "sub-simulation" programs were developed and used during this study of a representative region of Northeast Thailand. The typical data used in these simulations were obtained by the SAI team who visited the area during this study period.

This report is subdivided into three major parts which are:

- I Program Synopsis
- II Program Description
- III Appendices

14. KEY WORDS	LINK A		LINK B		LINK C	
	ROLE	WT	ROLE	WT	ROLE	WT
<p>TRANSPORTATION DEVELOPING AREA STUDY THAILAND CASE STUDY MATHEMATICAL MODELS ECONOMIC MODELS FORCE ALLOCATION VEHICLE/ROAD INTERATION COMPUTER PROGRAMS</p>						