

AEDC-TR-68-100
AD 669562

cy 1

**ARCHIVE COPY
DO NOT LOAN**



**DESIGN AND DEVELOPMENT
OF A SERVOCONTROLLED GAS INBLEED SYSTEM
FOR A HIGH VACUUM CALIBRATION CHAMBER**

Albert J. Mathews and Fred M. Shofner

ARO, Inc.

May 1968

This document has been approved for public release
and sale; its distribution is unlimited.

**AEROSPACE ENVIRONMENTAL FACILITY
ARNOLD ENGINEERING DEVELOPMENT CENTER
AIR FORCE SYSTEMS COMMAND
ARNOLD AIR FORCE STATION, TENNESSEE**

AEDC TECHNICAL LIBRARY



5 0720 00031 7323

PROPERTY OF U. S. AIR FORCE
AEDC LIBRARY
AF 40(600)1200

NOTICES

When U. S. Government drawings specifications, or other data are used for any purpose other than a definitely related Government procurement operation, the Government thereby incurs no responsibility nor any obligation whatsoever, and the fact that the Government may have formulated, furnished, or in any way supplied the said drawings, specifications, or other data, is not to be regarded by implication or otherwise, or in any manner licensing the holder or any other person or corporation, or conveying any rights or permission to manufacture, use, or sell any patented invention that may in any way be related thereto.

Qualified users may obtain copies of this report from the Defense Documentation Center.

References to named commercial products in this report are not to be considered in any sense as an endorsement of the product by the United States Air Force or the Government.

DESIGN AND DEVELOPMENT
OF A SERVOCONTROLLED GAS INBLEED SYSTEM
FOR A HIGH VACUUM CALIBRATION CHAMBER

Albert J. Mathews and Fred M. Shofner*
ARO, Inc.

This document has been approved for public release
and sale; its distribution is unlimited.

*F. M. Shofner is a consultant to ARO, Inc., and a professor of electrical engineering at the University of Tennessee Space Institute, Tullahoma, Tennessee.

FOREWORD

The work reported herein was done at the request of Headquarters, Arnold Engineering Development Center (AEDC), Air Force Systems Command (AFSC), under Program Element 6540215F, Project 4344, Task 434421.

The results of research reported herein were obtained by ARO, Inc. (a subsidiary of Sverdrup & Parcel and Associates, Inc.), contract operator of AEDC, AFSC, Arnold Air Force Station, Tennessee, under Contract AF40(600)-1200. The work was conducted under ARO Project No. SW5806, and the activities directly associated with the work extended from March 1 to September 1, 1967. The manuscript was submitted for publication on March 22, 1968.

This technical report has been reviewed and is approved.

J. G. Clark
Major, CF
Research Division
Directorate of Plans
and Technology

Edward R. Feicht
Colonel, USAF
Director of Plans
and Technology

ABSTRACT

A servocontrolled gas inbleed system for a dynamic, calibrated conductance type of vacuum calibration system was designed and fabricated. The servocontrolled gas inbleed system automatically regulates the flow of gas into the test region of the calibration system by maintaining a constant pressure on the upstream side of a molecular leak. Constant pressure on the molecular leak is established and maintained by a shunt control technique in which a gas inlet valve and a gas pumpout valve are operated in parallel. An analog computer was used to aid in the design of the system. The transient and steady-state response of the servocontrolled gas inbleed system is predicted by the computer. Good agreement was obtained between the analog computer data and the experimental performance data obtained from the gas inbleed system. The gas inbleed system can control the flow rate in the range from 10^{-5} torr-liters/sec to 10^{-3} torr-liters/sec. Other flow rates are obtainable by changing system components; however, the same design procedure is applicable.

CONTENTS

	<u>Page</u>
ABSTRACT	iii
NOMENCLATURE	vii
I. INTRODUCTION	1
II. DESIGN APPROACH	1
III. DESCRIPTION OF THE VACUUM CALIBRATION SYSTEM	2
IV. DESCRIPTION OF THE SERVOCONTROLLED GAS INBLEED SYSTEM	5
V. ANALYSIS AND EVALUATION OF THE SERVO- CONTROLLED GAS INBLEED SYSTEM USING NON- LINEAR ANALOG COMPUTER TECHNIQUES	6
VI. EXPERIMENTAL RESULTS	6
VII. CONCLUSIONS	8
REFERENCES	8

APPENDIXES

I. ILLUSTRATIONS

Figure

1. Vacuum Calibration System Schematic	11
2. Vacuum Calibration System Flow Diagram	12
3. Mechanical Schematic for the Servocontrolled Gas Inbleed System	13
4. Valve Conductance versus Gas Inlet Valve Shaft Angle	14
5. Valve Conductance versus Gas Pumpout Valve Shaft Angle	15
6. Servocontrolled Gas Inbleed System Flow Diagram	16
7. Error Signal (V_E) versus Gas Pumpout Amplifier Input Signal (V_{Phil})	17
8. Error Signal (V_E) versus Gas Inlet Amplifier Input Signal (V_{Phil})	18

<u>Figure</u>	<u>Page</u>
9. Gas Pumpout Amplifier Input Signal (V_{Phil}) versus Gas Pumpout Servomotor Control Voltage (V_{SM}).	19
10. Gas Inlet Amplifier Input Signal (V_{Phil}) versus Gas Inlet Servomotor Control Voltage (V_{SM})	20
11. Analog Computer Flow Diagram	21
12. Transient Response for a Forepressure Set Equal to 1×10^{-2} torr	22
13. Transient Response for a Forepressure Set Equal to 3.33×10^{-2} torr	23
14. Transient Response for a Forepressure Set Equal to 1.0×10^{-1} torr	24
15. Transient Response for a Forepressure Set Equal to 3.3×10^{-1} torr	25
16. Transient Response for a Forepressure Set Equal to 1.0 torr	26
17. Transient Response for a Forepressure Set Equal to 1.0 torr	27
II. SAMPLE CALCULATION FOR THE NUMERICAL VALUES OF C_3	28
III. SAMPLE CALCULATION FOR THE NUMERICAL VALUES OF C_4	29
IV. TABLES	
I. EXPERIMENTAL DATA USED TO CALCULATE C_3	30
II. EXPERIMENTAL DATA USED TO CALCULATE C_4	31

NOMENCLATURE

C	Equivalent capacitance for volume between molecular leak, gas inlet valve, gas pumpout valve, and differential pressure meter
C_1	Molecular leak conductance
C_2	Circular orifice conductance
C_3	Gas inlet valve conductance
C_4	Gas pumpout valve conductance
CCW	Counterclockwise
CW	Clockwise
K_{mi}	Gas inlet servomotor gain constant
K_{mo}	Gas pumpout servomotor gain constant
n'	Moles of gas
P_2	Vacuum chamber test region pressure
P_3	Diffusion pump pressure
P_{EB}	Molecular leak forepressure
P_r	Differential pressure meter reference pressure
P_α	Alphatron pressure
Q	Gas flow rate into volume V
ΔQ	Net flow rate
Q_1	Gas flow rate through molecular leak C_1
Q_2	Gas flow rate through calibrated orifice C_2
Q_3	Gas flow rate through gas pumpout valve
Q_4	Gas flow rate through gas inlet valve
R_o	Universal gas constant
T	Temperature of gas
T_1	Servomotor time constant
T_2	Servomotor time constant
T_3	Servomotor time constant
V	Volume between V_2 , differential pressure meter, C_1 , and V_1

V_1	Gas inlet valve
V_2	Gas pumpout valve
V_E	Error signal, numerical difference between the reference signal and the differential pressure meter signal
V_{EB}	Differential pressure meter signal, equivalent to the actual test region pressure
V_{Phil}	Gas pumpout amplifier and gas inlet amplifier signal, . limit switches not activated
V_R	Reference signal, equivalent to desired test region pressure
V_{SM}	Gas inlet servomotor control voltage
θ_{in}	Gas inlet valve shaft angle
θ_{out}	Gas pumpout valve shaft angle

SECTION I INTRODUCTION

Space simulation and testing require accurate measurement of total and partial pressures below 10^{-4} torr. Ionization gages and mass spectrometers are commonly used and are basically gas density measuring devices whose sensitivities vary with the type of gas. Vacuum measurement with these instruments is a complicated process involving calibration of instrument response to absolute pressure and a careful application of this calibration in measurement of unknown pressures.

To establish working standard pressures for the calibration of total and partial pressure instruments below 10^{-4} torr, a dynamic, calibrated conductance type of vacuum calibration system was designed and fabricated at the Arnold Engineering Development Center Aerospace Environmental Facility (AEF) (Ref. 1).

Working standard partial pressures have been established with an accuracy of ± 5 percent throughout the range from 10^{-8} to 10^{-4} torr. A standard pressure was established by introducing nitrogen (N_2) gas through a porous leak into a test region which is exhausted through an orifice in a thin diaphragm. The accuracy with which the pressure in the test region can be established is dependent on establishing a constant, known flow rate through the porous leak.

The purpose of this study was to design and develop a servocontrolled gas inbleed system to maintain constant flow rates into the test region of the calibration system. The design approach is generally applicable to other gas inbleed control systems.

SECTION II DESIGN APPROACH

After the study of other servotechniques, a shunt controller was developed by Shofner for use in the study of large signal transient response in dc-pumped helium-neon plasma lasers (Ref. 2). Although this was an electronic circuit involving a tetrode shunt tube in parallel with a laser to shunt current away from the laser, the same principle of operation can be applied to a gas inbleed system. The gas inbleed valve can be shunted by a gas pumpout valve to shunt gas away from the inbleed valve. Consequently, the overshoot transient response of the flow system is greatly reduced and contamination problems of the gas inbleed system are eliminated by purging the system through the gas pumpout valve.

The conventional approach to the design of servocontrolled systems is to use linear network analysis to determine system stability and optimization. Techniques for the analysis of linear systems include Routh's stability criteria and root-locus stability criteria (Ref. 3). To apply these techniques to nonlinear systems, operating points are chosen, and linear approximations are made around these points. These techniques can then be utilized to determine stability and optimization. However, a linear analysis of nonlinear systems is only an approximation. A better approach than linear approximations is a nonlinear analysis made on an analog computer. The insertion of the characteristics of various nonlinear elements such as control valves and amplifiers is readily made on an analog computer. The transient and steady-state response of each element in the servoloop, as well as their combined effect, can be recorded. In addition, the computer can show the results in "real time" or in "fast time." A feature of the "fast time" selector is the ability to speed up the computer so that the steady-state response for an extended period of time can be represented during a short period.

SECTION III DESCRIPTION OF THE VACUUM CALIBRATION SYSTEM

Figure 1 (Appendix I) shows the major components of the calibration system. To maintain a constant test region pressure, P_2 , the forepressure P_{EB} must be held constant. Any drift in the forepressure is corrected by means of the servocontrolled valves V_1 and V_2 . Opening valve V_1 , a needle valve, enables an increase in the foreline pressure, whereas opening valve V_2 , a coarse valve, enables a decrease in the foreline pressure. A needle valve was chosen for the gas inlet valve so that a very fine control over the increase in forepressure could be obtained. A coarse valve was chosen for the pumpout valve so that purging of the system could be accomplished in a minimum amount of time, and the overpressure transient response would be short. The capacitance manometer provides a control signal for the gas inbleed servosystem. The reference pressure, P_r , of this instrument is held constant at 2×10^{-3} torr by means of a mechanical pump. The range of the instrument is from 0.01 to 30.0 torr.

The flow diagram for the test region portion of the vacuum calibration system is shown in Fig. 2. Gas is introduced into the test region through a molecular leak of conductance C_1 and is pumped from the test region through a circular orifice of conductance C_2 . The test region pressure, P_2 , is calculated by equating the flow through the leak to the

flow through the circular orifice at equilibrium. At constant temperature, this leads to the following relationship

$$C_1(P_{EB} - P_2) = C_2(P_2 - P_3) \quad (1)$$

By choosing a molecular leak with a small value of conductance, P_2 can be made much smaller than P_{EB} . Similarly, P_3 can be made much smaller than P_2 by using a diffusion pumping speed much larger than the orifice conductance. The above equation can then be reduced to (Ref. 1)

$$P_2 = \frac{C_1}{C_2} P_{EB} \quad (2)$$

For the vacuum system used in this work, the conductances for N_2 were

$$C_1 = 6.85 \times 10^{-3} \text{ liters/sec}$$

$$C_2 = 6.00 \times 10^1 \text{ liters/sec}$$

$$\text{Diffusion Pumping} = 6 \times 10^3 \text{ liters/sec}$$

$$P_{EB} \text{ varies from } 10^{-2} \text{ to } 1.0 \text{ torr}$$

With these values the calibrated pressure, P_2 , in the test region can be set between the limits of 1.14×10^{-6} to 1.14×10^{-4} torr.

The flow diagram for the servocontrolled portion of the vacuum calibration system is shown in Fig. 3. The flow as a function of time can be calculated from the equation of state for an ideal gas.

$$PV = n' R_0 T \quad (3)$$

where n' is the number of moles in volume V at temperature T ; R_0 is a universal gas constant. Taking the total time derivative gives

$$P \frac{dV}{dt} + V \frac{dP}{dt} = \frac{dn'}{dt} R_0 T = Q \quad (4)$$

Since

$$\frac{dV}{dt} = 0 \quad (5)$$

$$Q = V \frac{dP}{dt} \quad (6)$$

The net flow in the forepressure line is given by

$$\Delta Q = Q_4 - Q_1 - Q_3 \quad (7)$$

where

$$Q_1 = C_3 (P_a - P_{EB})$$

$$Q_2 = C_1 P_{EB}$$

$$Q_3 = C_4 P_{EB}$$

The forepressure, P_{EB} , as a function of time can then be written

$$\frac{dP_{EB}}{dt} = \frac{1}{V} \left[C_3 (P_a - P_{EB}) - C_1 P_{EB} - C_4 P_{EB} \right] \quad (8)$$

where V is the volume between V_2 , the capacitance manometer, C_1 , and V_1 in Fig. 3. This volume was determined to be 1.235 liters. The pressure P_a , on the upstream side of valve V_1 is measured with an Alpatron[®] gage and maintained constant by means of the vacuum regulator. The forepressure, P_{EB} , is measured with the capacitance manometer and provides the control signal for the servosystem. The molecular leak conductance, C_1 , remains constant and was determined to be 6.85×10^{-3} liters/sec by a procedure given in Ref. 1. The conductance C_3 of the gas inlet valve as a function of valve shaft angle, θ_{in} , and Alpatron pressure, P_a , is given in Fig. 4. The curves were obtained by closing the gas pumpout valve, $C_4 = 0$, and letting the system reach steady state for various valve shaft angles. The conductance C_3 was then calculated (see Appendix II) directly from Eq. (8). Figure 4 shows that the conductance of the inlet valve as a function of shaft angle is nonlinear. The fact that the conductance of the inlet valve is a nonlinear function of Alpatron pressure indicates that the valve is operating in the transition flow region. Molecular flow equations were used throughout this study, and the appropriate curve for a particular Alpatron pressure was used. Molecular flow equations assume the conductance terms to be independent of pressure. By operating along a single Alpatron pressure curve, this requirement is satisfied.

The conductance C_4 of the gas pumpout valve as a function of valve shaft angle, θ_{out} , and forepressure is given in Fig. 5. The downstream pressure of the gas pumpout valve, 2×10^{-3} torr, is negligible when compared to the upstream forepressure. These curves were obtained by presetting the inlet valve to give a nominal forepressure. The gas pumpout valve was then opened, and the system was allowed to reach steady state for various valve shaft angles. The conductance C_4 was then calculated (see Appendix III) directly from Eq. (8). The above comments that were made about the curves shown in Fig. 4 are also applicable to Fig. 5.

The fact that the conductance of the pumpout valve is a function of the foreline pressure indicates that the valve is operating in the transition flow region. To use molecular flow equations, the appropriate curve for a particular foreline pressure must be used so that the conductance terms in the equations are independent of pressure.

SECTION IV DESCRIPTION OF THE SERVOCONTROLLED GAS INBLEED SYSTEM

The servocontrolled gas inbleed system is shown schematically in Fig. 6. A reference signal, equivalent to the desired test region pressure, is compared to the differential pressure meter signal which is proportional to the actual test region pressure. The resulting dc error signal is amplified and chopped. This error signal is applied to the gas pumpout power amplifier and the gas inlet power amplifier, respectively. The resulting signal from each power amplifier is applied to the gas pumpout servomotor and gas inlet servomotor, respectively. The gas inlet servomotor then drives the gas inlet valve, V_1 , open or closed depending on the polarity of the error signal. Likewise, the gas pumpout servomotor drives the gas pumpout valve, V_2 , open or closed depending on the polarity of the error signal. The phase shift of the servomotors is such that the rotation of the gas inlet and gas pumpout valves is opposite for a given error signal polarity. Full close and full open limit switches were installed on the valves to keep them from mechanically binding when they reach the end of their travel. This was accomplished by substituting 1.37 v for V_E and opposite in polarity to V_E when the full open and full closed limit switches were activated by stops on the valve shafts.

Figures 7 and 8 show the characteristics of the dc amplifier as an integral part of the servosystem. As indicated, the rotation of the valve shafts is opposite for a particular error signal polarity. Also, a dead zone exists whereby the error signal must exceed +1 mv before the valves will start to open or close. As indicated by the graphs, a dc level exists; that is, for zero error signal, -0.3 v were obtained at the input to the power amplifiers.

Figures 9 and 10 show the characteristics of the gas pumpout and gas inlet power amplifiers, respectively. Dead zone and motor shaft rotation is indicated in the graphs. To eliminate the possibility of the valves oscillating against each other, the gain of the inlet valve was set lower than the pumpout valve. Thus, for a certain error voltage, the

inlet valve rotates at a lower speed and comes to rest before the gas pumpout valve.

SECTION V ANALYSIS AND EVALUATION OF THE SERVOCONTROLLED GAS INBLEED SYSTEM USING NONLINEAR ANALOG COMPUTER TECHNIQUES

The analog computer flow diagram for the servocontrolled gas inbleed system is shown in Fig. 11. The reference signal, V_R , which is equivalent to the desired test region pressure, is compared to the differential pressure meter signal, V_{EB} , which is equivalent to the actual forepressure. The error signal, V_E , which is equivalent to the error pressure, is amplified by a dc amplifier — depicted by the first two blocks. If neither of the limit switches on the gas pumpout valve and on the gas inlet valve is activated, the error signal proceeds to both the gas pumpout and gas inlet power amplifiers. If one or both of the valves are near the full open or full close position, the appropriate limit switch will be activated according to valve shaft position to apply a constant error signal of 1.37 v to keep the valve from binding open or closed. The error signal is applied to the servomotor transfer functions. The resulting valve shaft angle positions are applied to the conductance function generators to give conductance values as a function of valve shaft angle. The particular operating curve of the gas pumpout conductance function generator is chosen according to the forepressure range; the operating curve of the gas inlet conductance function generator is chosen according to the Alphasatron pressure. The instantaneous value of the gas pumpout conductance C_4 , and the gas inlet conductance C_3 , is substituted into the differential equation, which describes the vacuum portion of the gas inbleed system (see Eq. (8)). The forepressure line volume V , the molecular leak conductance C_1 , and the Alphasatron pressure P_α are constants. The computer solves for the resulting forepressure P_{EB} and plots it as a function of time.

SECTION VI EXPERIMENTAL RESULTS

Figures 12 through 17 show the analog computer solutions for various operating conditions. The experimental data obtained from the physical system are plotted in the same graph so that a direct comparison between analog computer and experimental data can be made. The forepressure, error signal, gas inlet valve shaft position, and gas pumpout valve shaft

position are plotted as functions of time in each graph. Full close on each valve is represented by zero shaft degrees. The gas inlet valve is full open at 4590 deg; the gas pumpout valve is full open at 1710 deg.

Figure 12 shows the transient and steady-state response of the system for an Alphasatron pressure of 3.1 torr and a voltage step of +10 mv at the reference input. The capacitance manometer output at a steady-state forepressure of 1×10^{-2} torr is +10 mv when the manometer range is set at 30×10^{-3} torr full scale. The response time of the physical system is better than that predicted by the analog computer. The pumpout valve oscillation which occurred in the computer solution is not understood. The experimental and computer data show the system to be stable for at least 150 sec. Since experimental data were not obtained beyond 150 sec, the oscillation cannot be verified or denied by experimental data. The computer data show the system to be stable for at least 450 sec. It is believed, however, that the system is capable of holding a steady forepressure of 1×10^{-2} torr indefinitely.

Figure 13 shows the transient and steady-state response of the system for an Alphasatron pressure of 3.1 torr, a voltage step input of +10 mv, and a capacitance manometer range of 1×10^{-1} torr full scale. These settings establish a steady-state forepressure of 3.3×10^{-2} torr. The data obtained in Fig. 13 are similar to the data obtained in Fig. 12. The oscillation of the pumpout valve is verified by experimental data. Even so, the system is capable of holding a steady forepressure of 3.3×10^{-2} torr.

Figure 14 shows the transient and steady-state response of the system for an Alphasatron pressure of 25.0 torr, a voltage step input of +10 mv, and a capacitance manometer range of 0.30 torr full scale. The same characteristics that were made evident by Figs. 12 and 13 are shown in Fig. 14. Again the system is capable of holding a steady forepressure of 1×10^{-1} torr for the above conditions.

Figure 15 shows the system to be stable for an Alphasatron pressure of 28.0 torr, a voltage step input of +10 mv, and a capacitance manometer range of 1.0 torr full scale; however, oscillation of the pumpout valve is of such magnitude as to keep the error signal from reaching zero and the forepressure from stabilizing. The pressure snubber effect of the molecular leak C_1 (see Fig. 2) was sufficient to keep the test region pressure constant; thus a constant test region pressure of 3.7×10^{-5} torr, which is equivalent to a forepressure of 3.3×10^{-1} torr, can be obtained.

Figures 16 and 17 show the system to be stable and capable of holding a steady forepressure of 1.0 torr for an Alphasatron pressure of 29.5 and 82.0 torr, respectively. The effect of the upstream pressure of the inlet valve on system response is evident from Figs. 16 and 17. The greater the Alphasatron pressure, the faster the system responds, as would be expected.

To summarize, Figs. 12 through 17 show that the gas inbleed system is capable of holding a constant pressure in the test region between the limits of 1.14×10^{-6} torr to 1.14×10^{-4} torr.

SECTION VII CONCLUSIONS

The feasibility of a shunt servocontrolled gas inbleed system for a high vacuum calibration chamber has been demonstrated. By shunting the gas inlet valve with a gas pumpout valve, the overshoot and time response of the inbleed system can be improved over using only a gas inbleed valve. The many advantages of using an analog computer for a nonlinear system analysis were demonstrated during the design and evaluation of the system.

REFERENCES

1. Sherrell, F. G. and Mathews, A. J. "A High Vacuum Calibration System." AEDC-TDR-64-275 (AD454480), January 1965.
2. Shofner, F. and Pierce, J. F. "Pulse Generator for Studying Transients in Plasma Lasers." Review of Scientific Instruments, Vol. 38, August 1967, pp. 1173-1175.
3. Savant, C. J., Jr. Basic Feedback Control Systems Design. McGraw-Hill Book Company, Inc., New York, 1958.

APPENDIXES

- I. ILLUSTRATIONS**
- II. SAMPLE CALCULATION FOR THE NUMERICAL VALUES OF C_3**
- III. SAMPLE CALCULATION FOR THE NUMERICAL VALUES OF C_4**
- IV. TABLES**

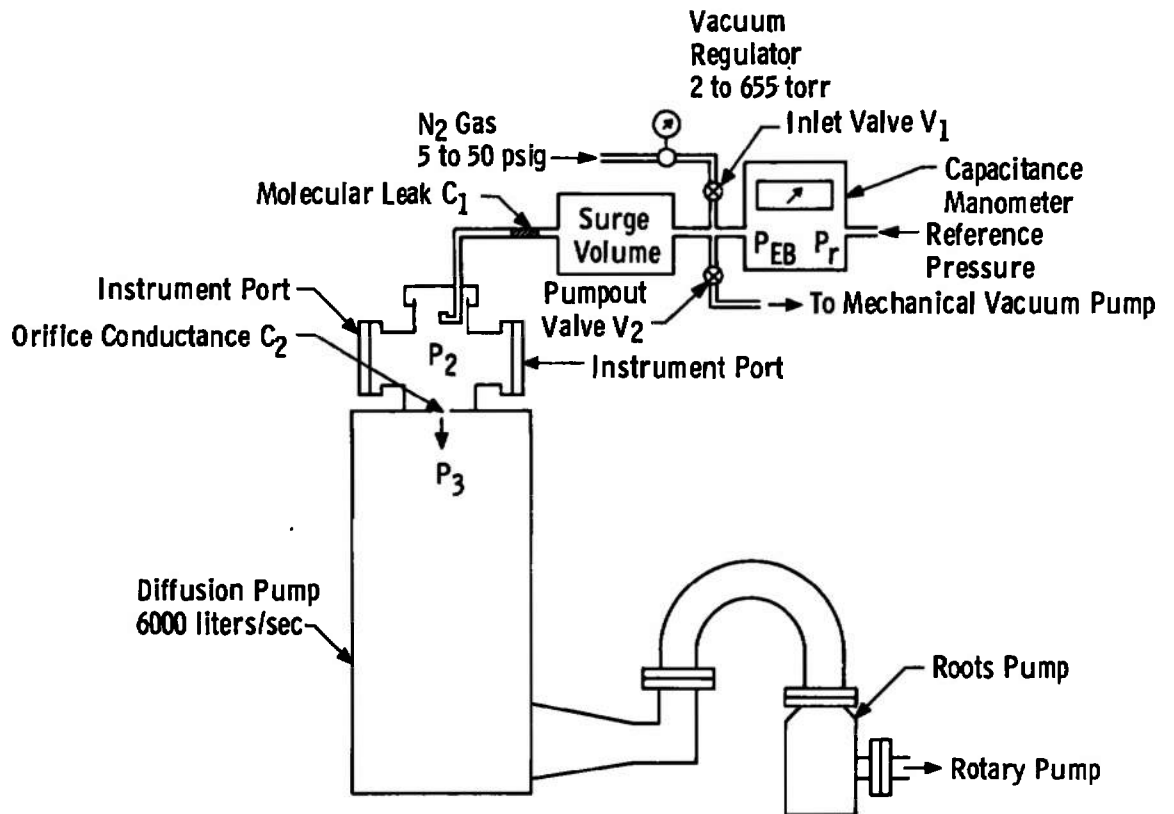

Fig. 1 Vacuum Calibration System Schematic

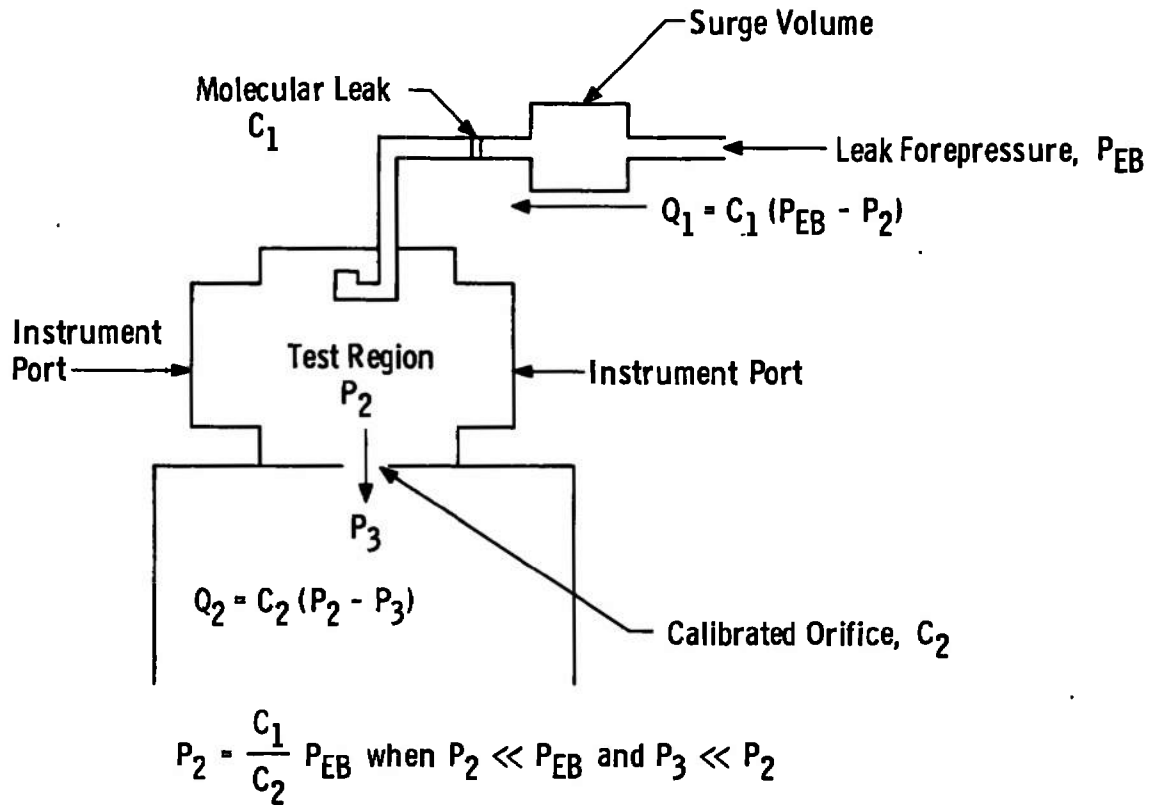

Fig. 2 Vacuum Calibration System Flow Diagram

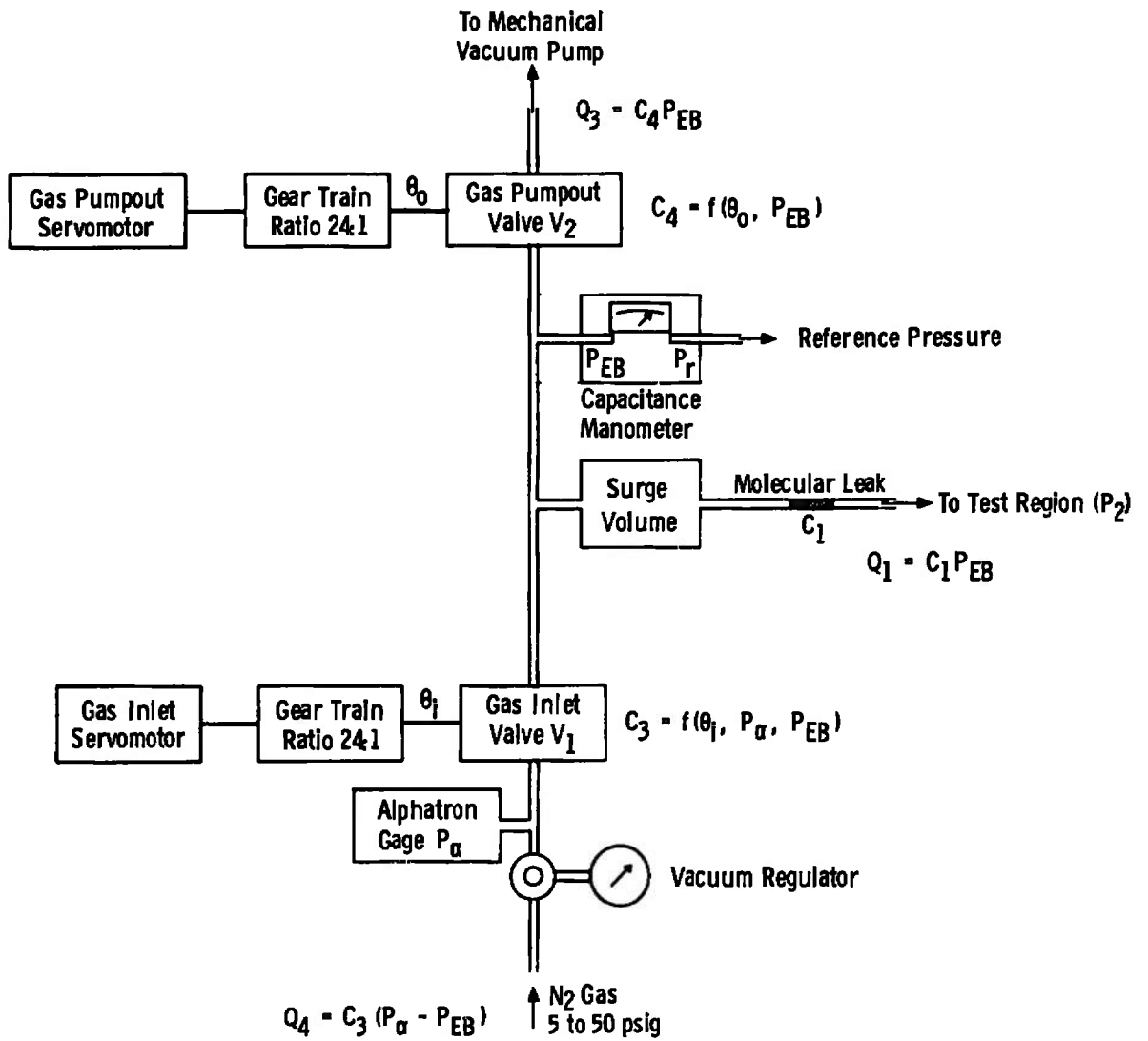

Fig. 3 Mechanical Schematic for the Servocontrolled Gas Inbleed System

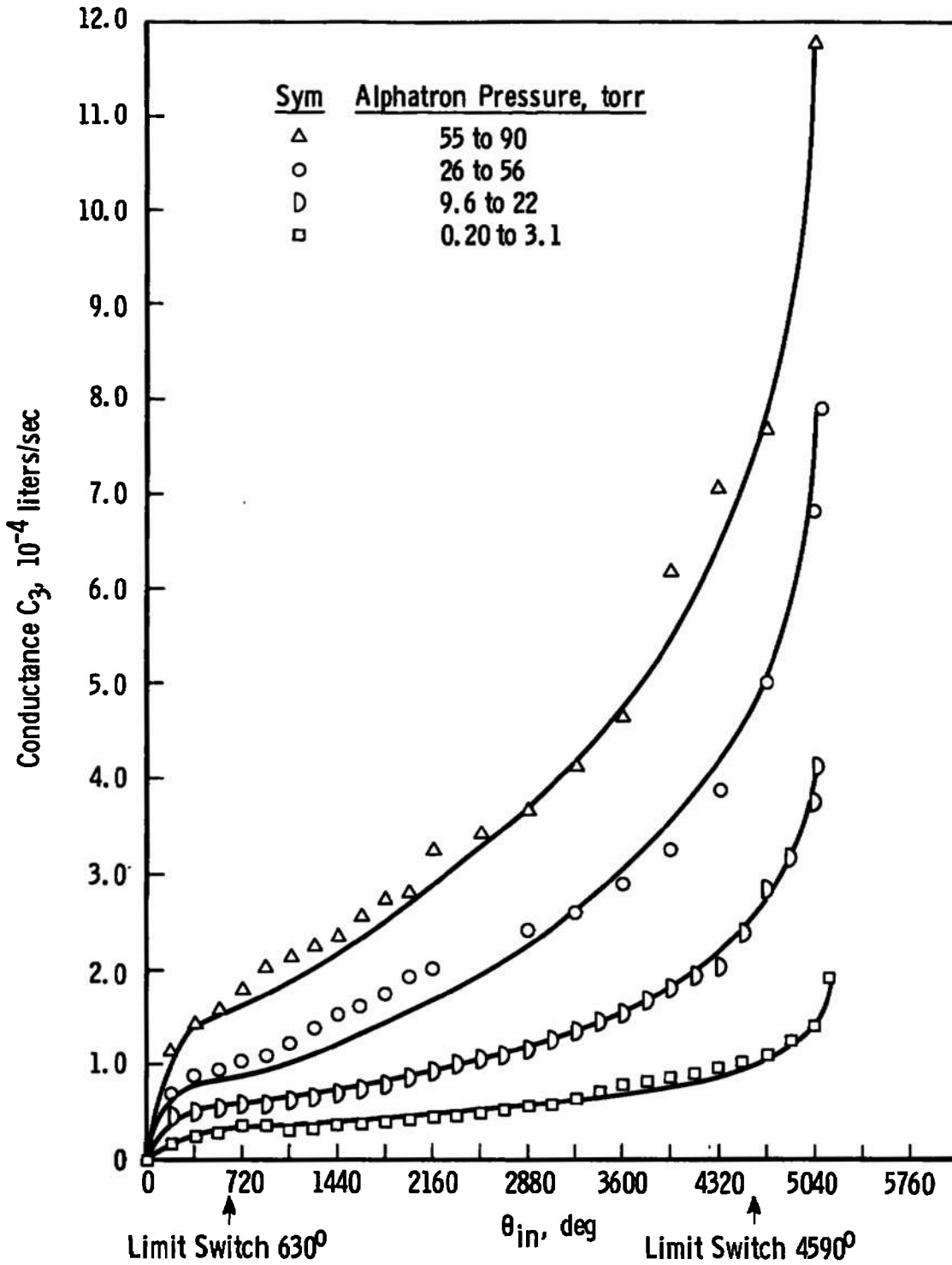

Fig. 4 Valve Conductance versus Gas Inlet Valve Shaft Angle

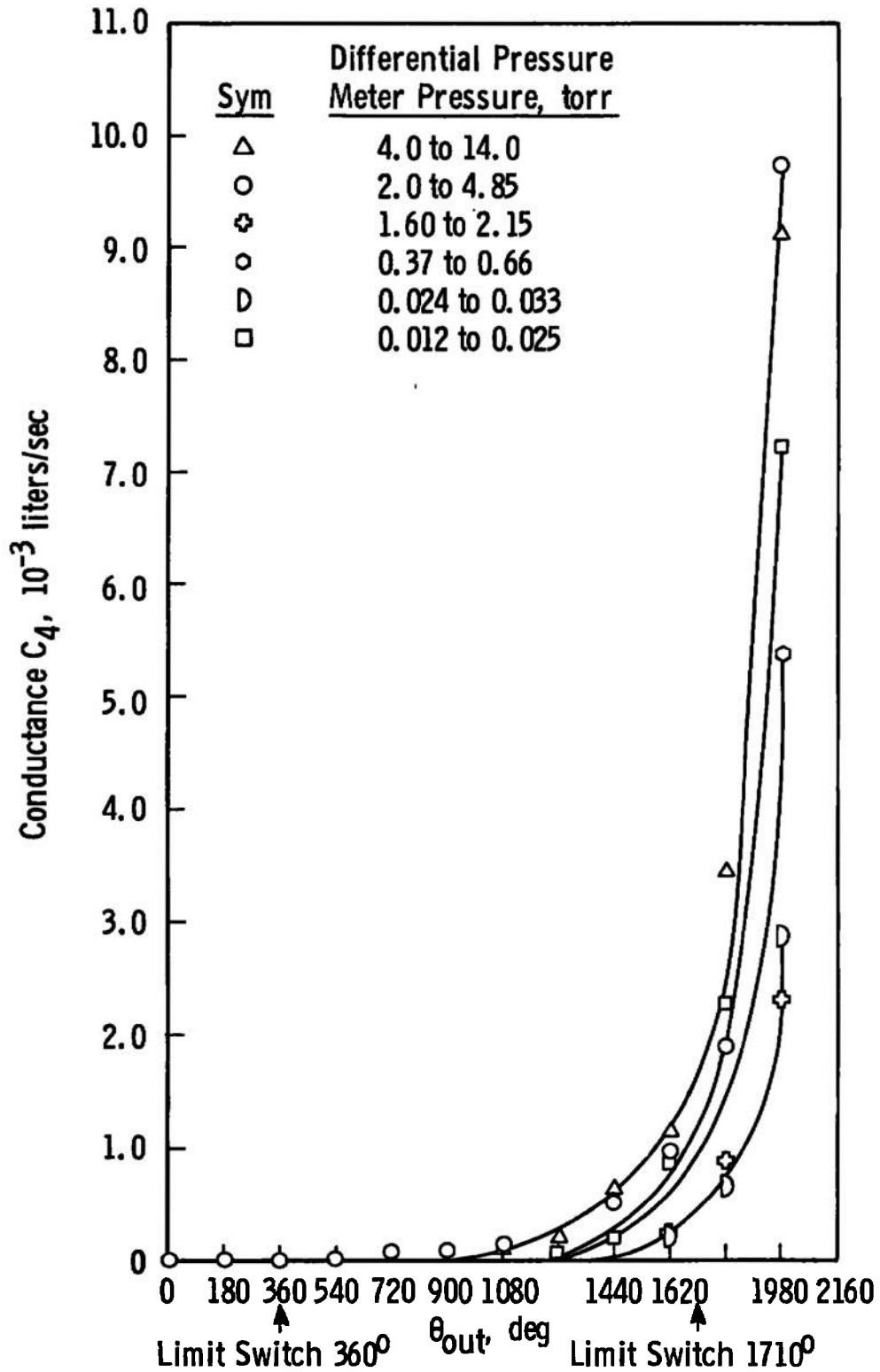

Fig. 5 Valve Conductance versus Gas Pumpout Valve Shaft Angle

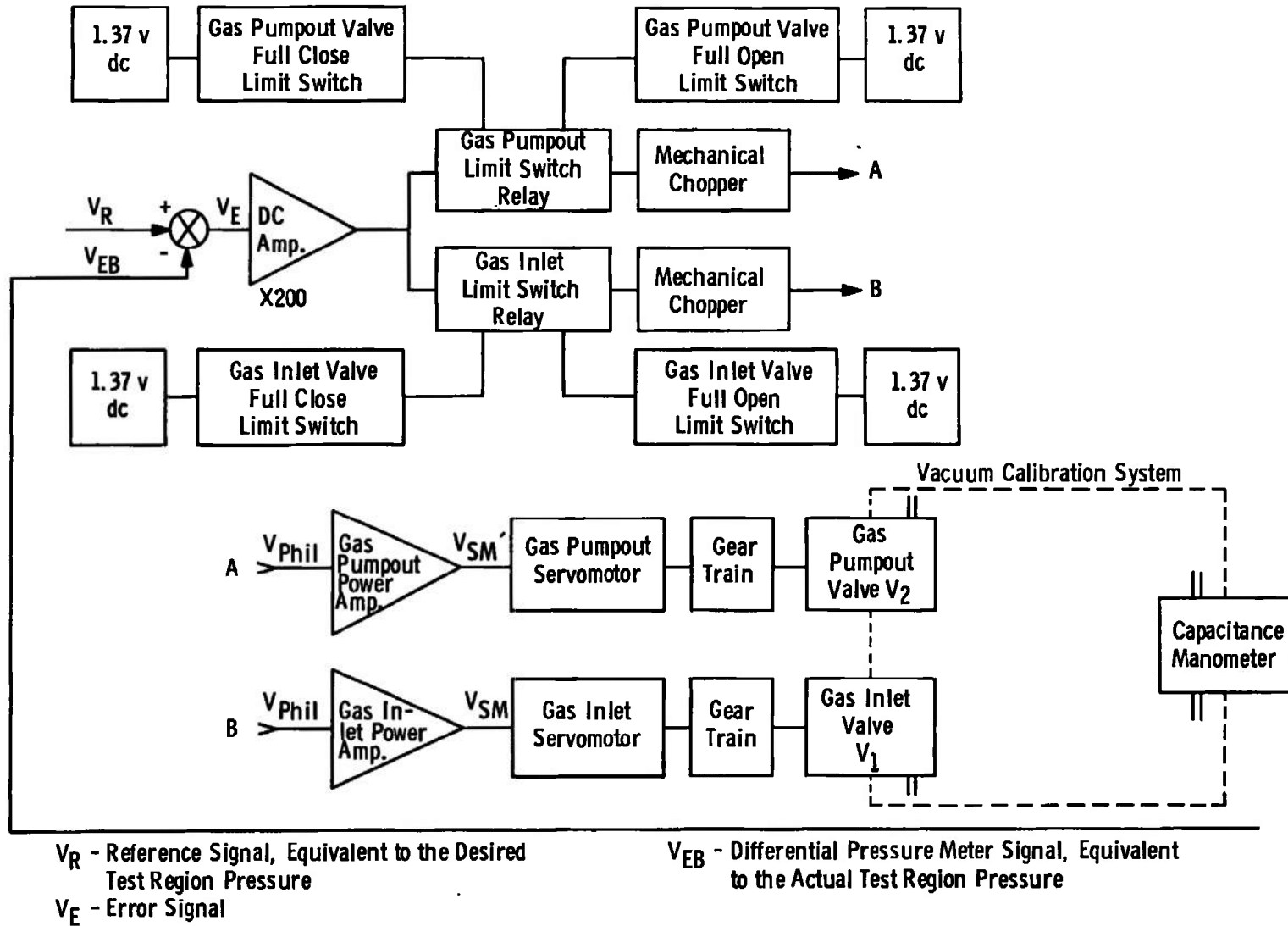

Fig. 6 Servocontrolled Gas Inbleed System Flaw Diagram

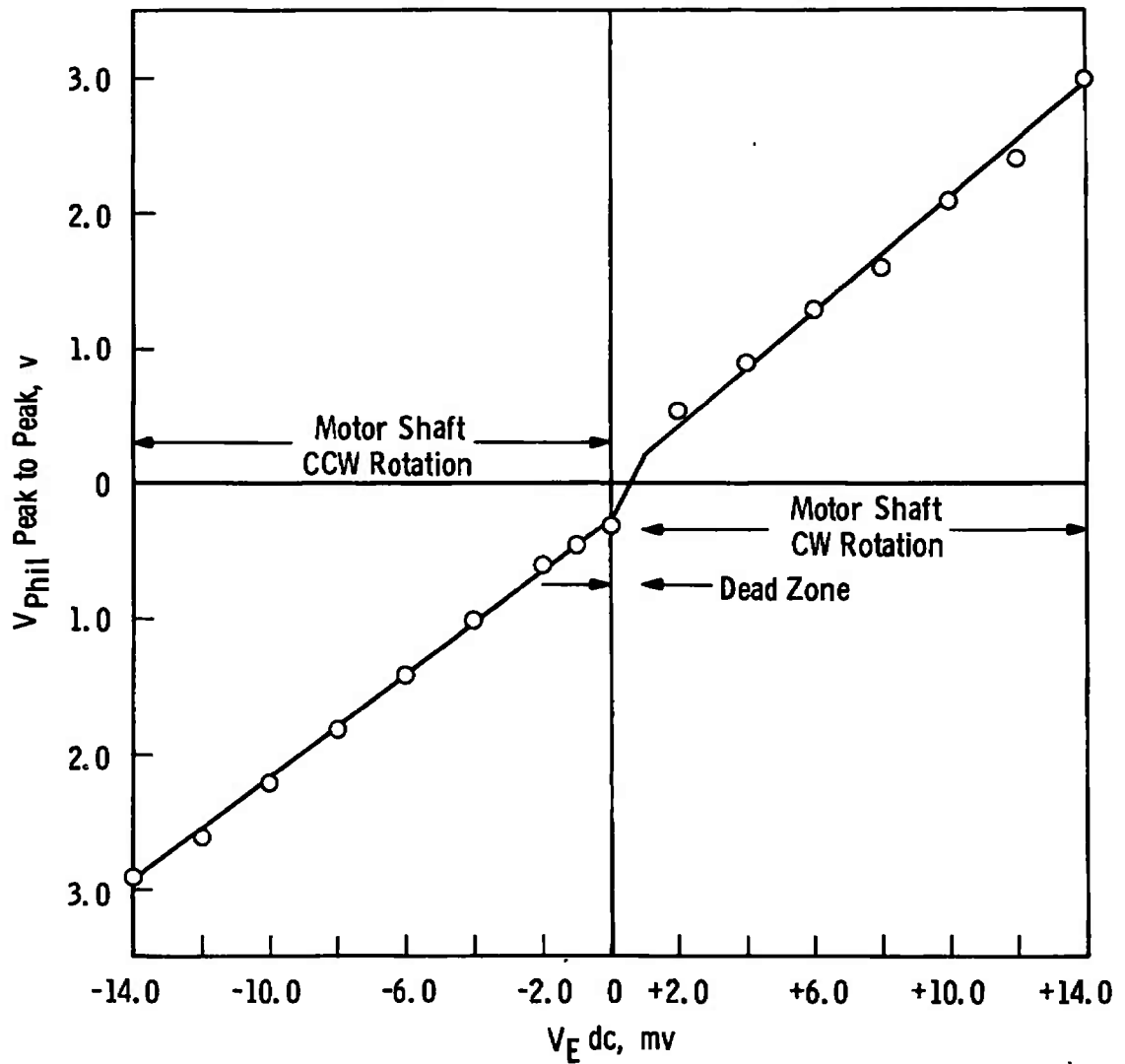

Fig. 7 Error Signal (V_E) versus Gas Pumpout Amplifier Input Signal (V_{ϕ})

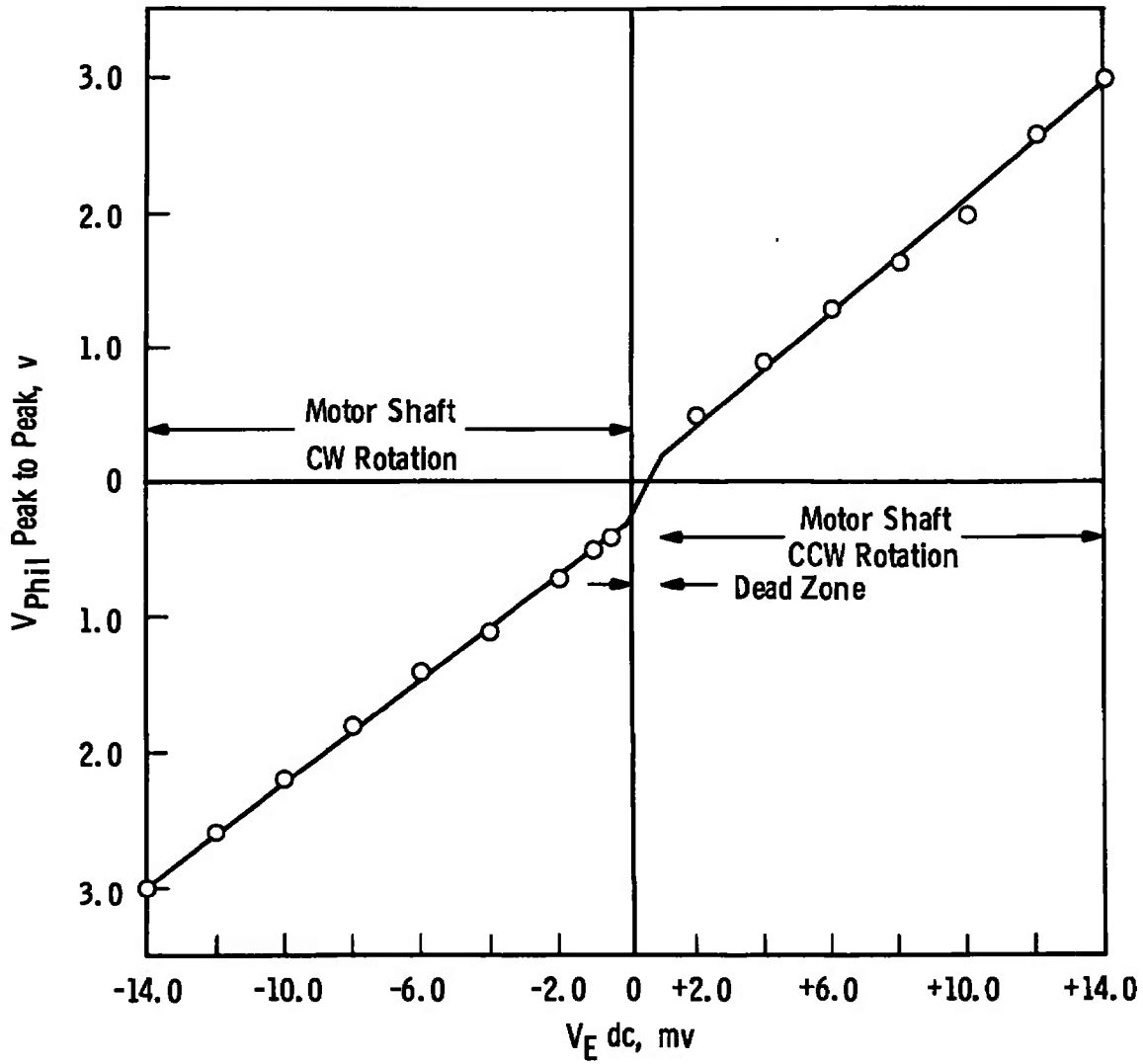

Fig. 8 Error Signal (V_E) versus Gas Inlet Amplifier Input Signal (V_{Phil})

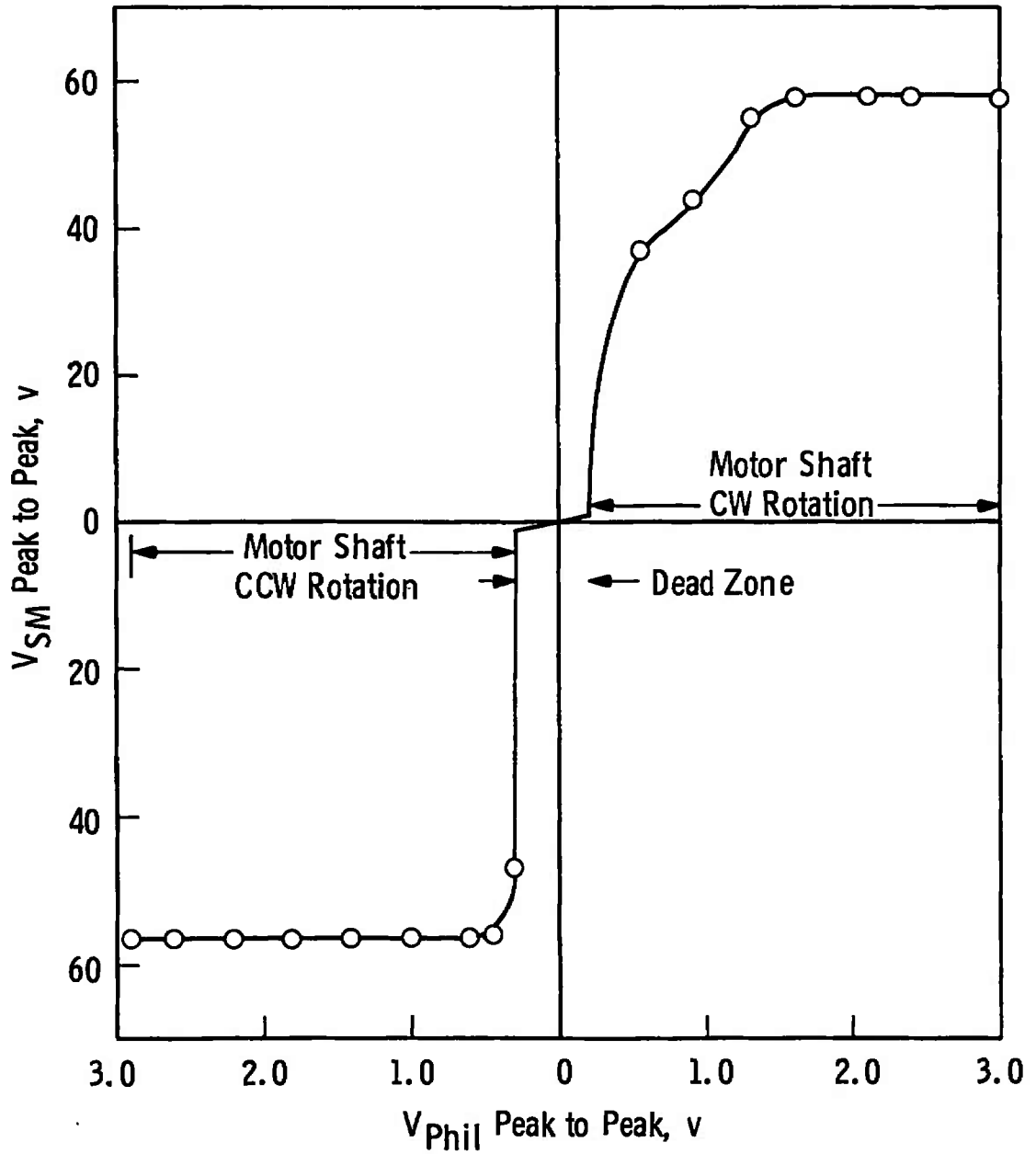

Fig. 9 Gas Pumpout Amplifier Input Signal (V_{phil}) versus Gas Pumpout Servomotor Control Voltage (V_{SM})

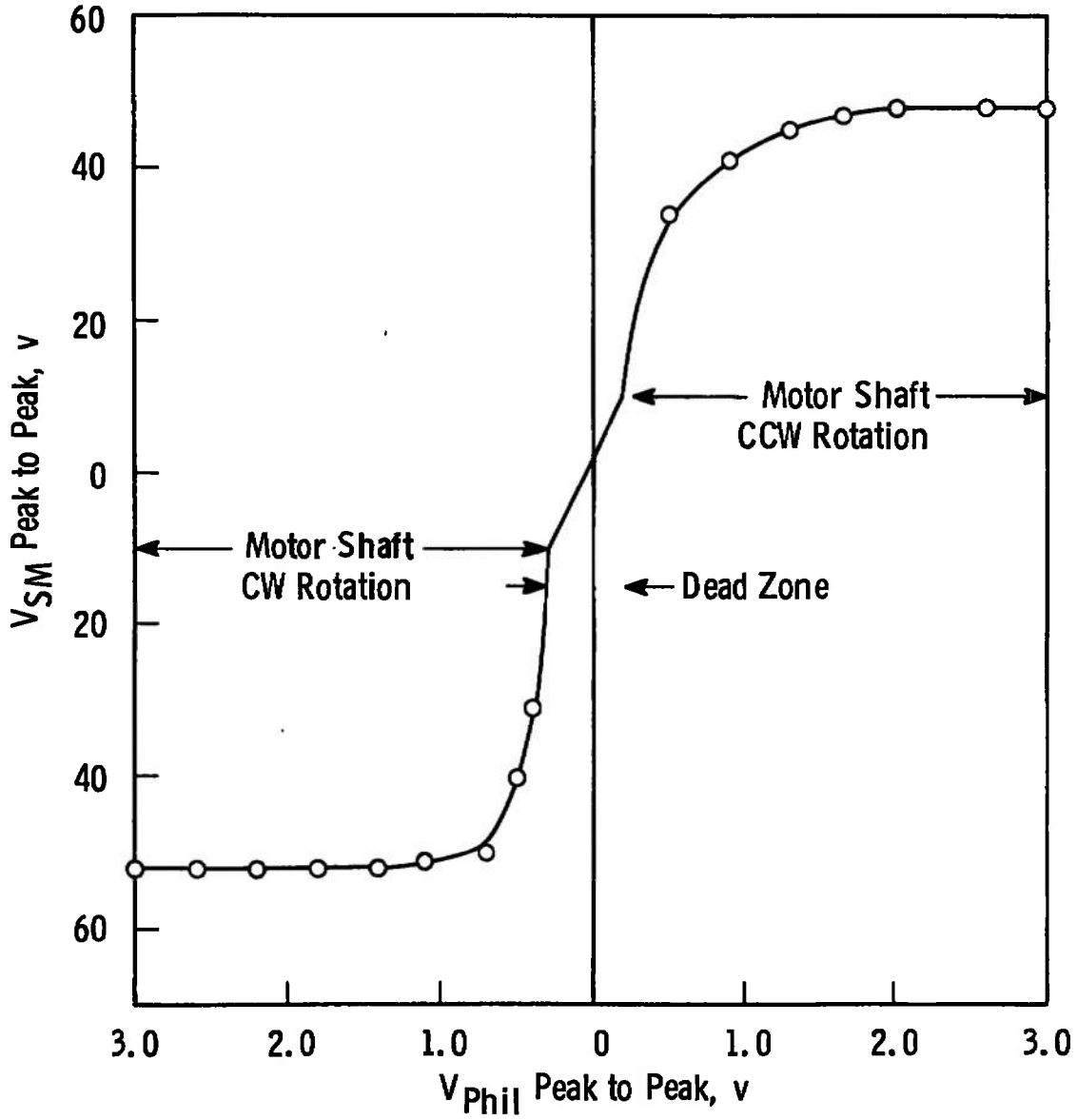

Fig. 10 Gas Inlet Amplifier Input Signal (V_{Phil}) versus Gas Inlet Servomotor Control Voltage (V_{SM})

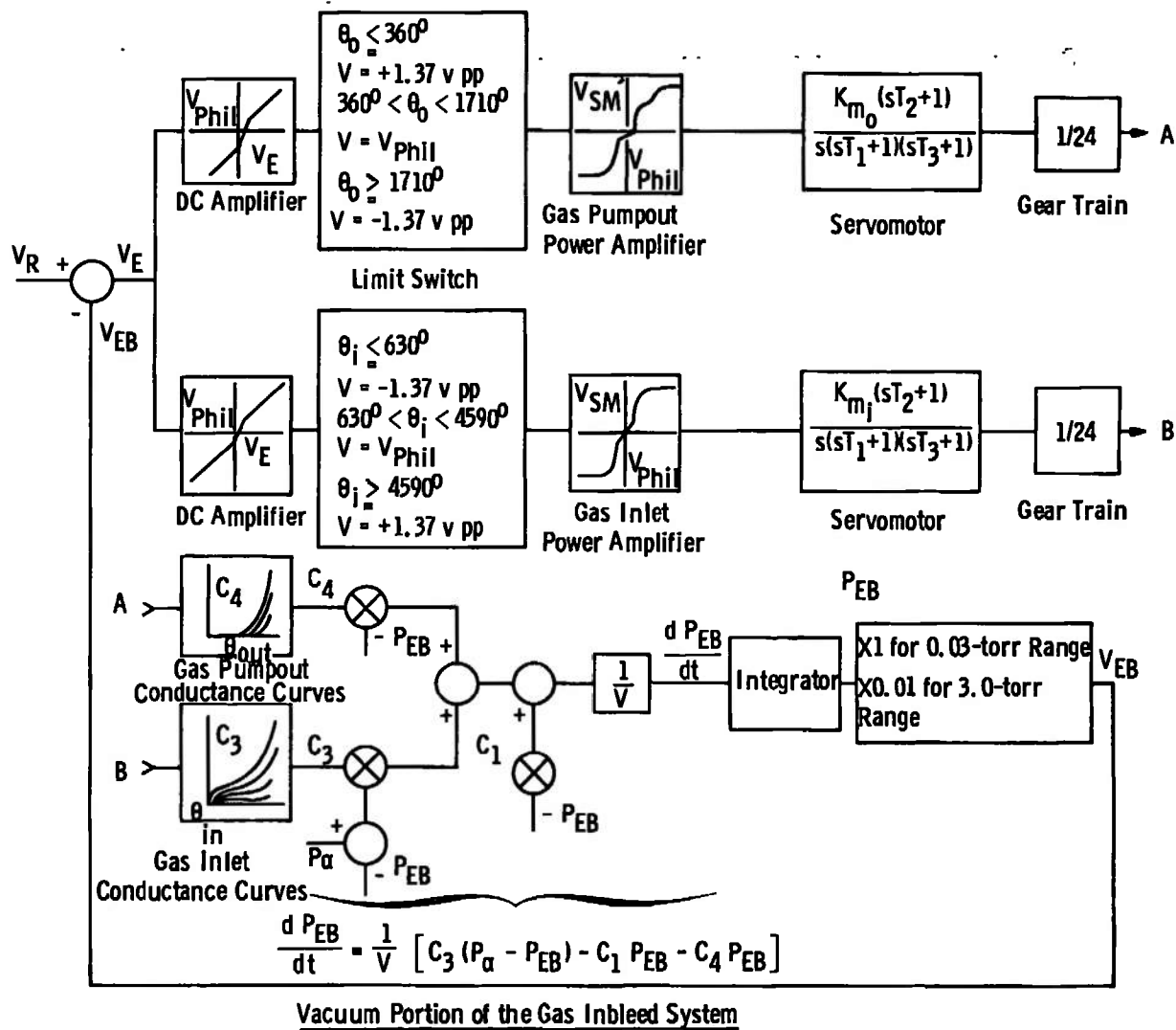

Fig. 11 Analog Computer Flow Diagram

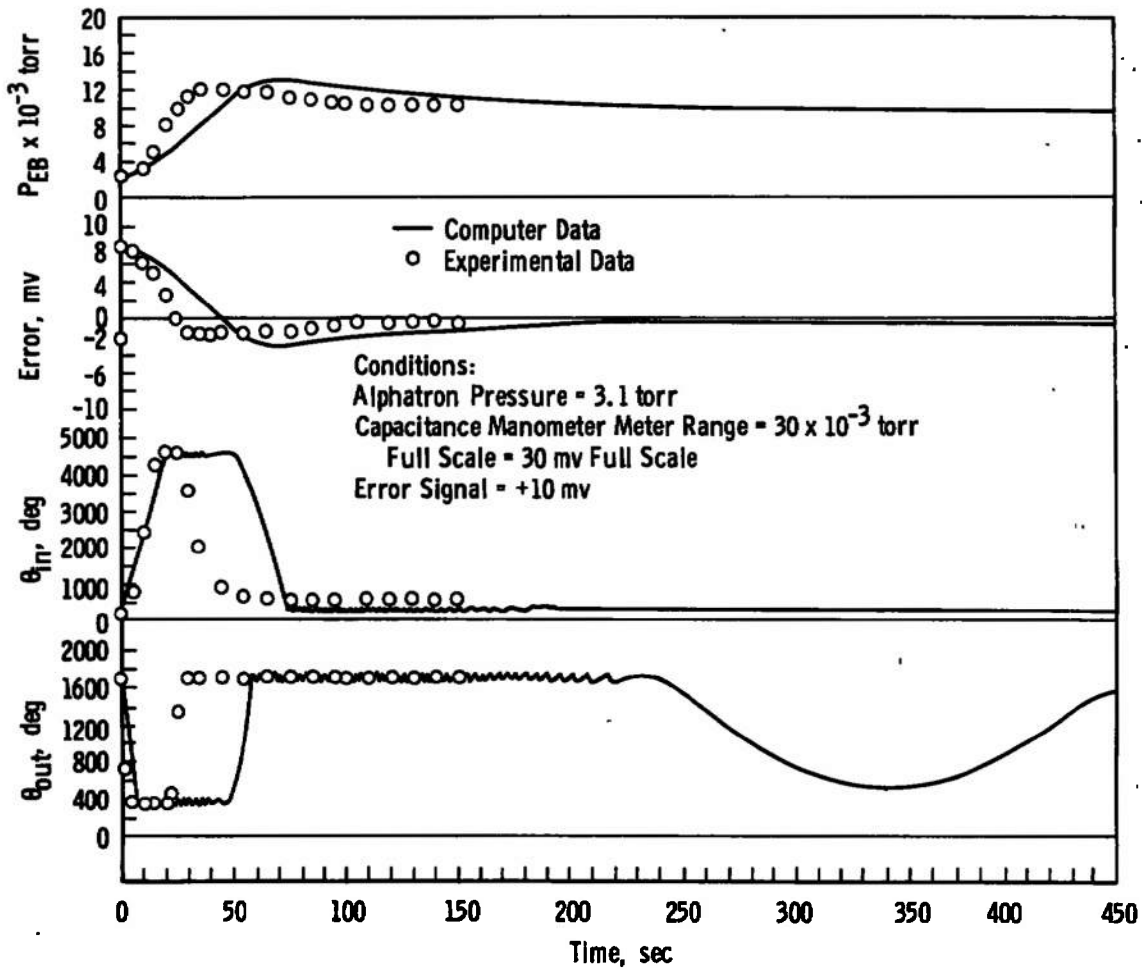

Fig. 12 Transient Response for a Forepressure Set Equal to 1×10^{-2} torr

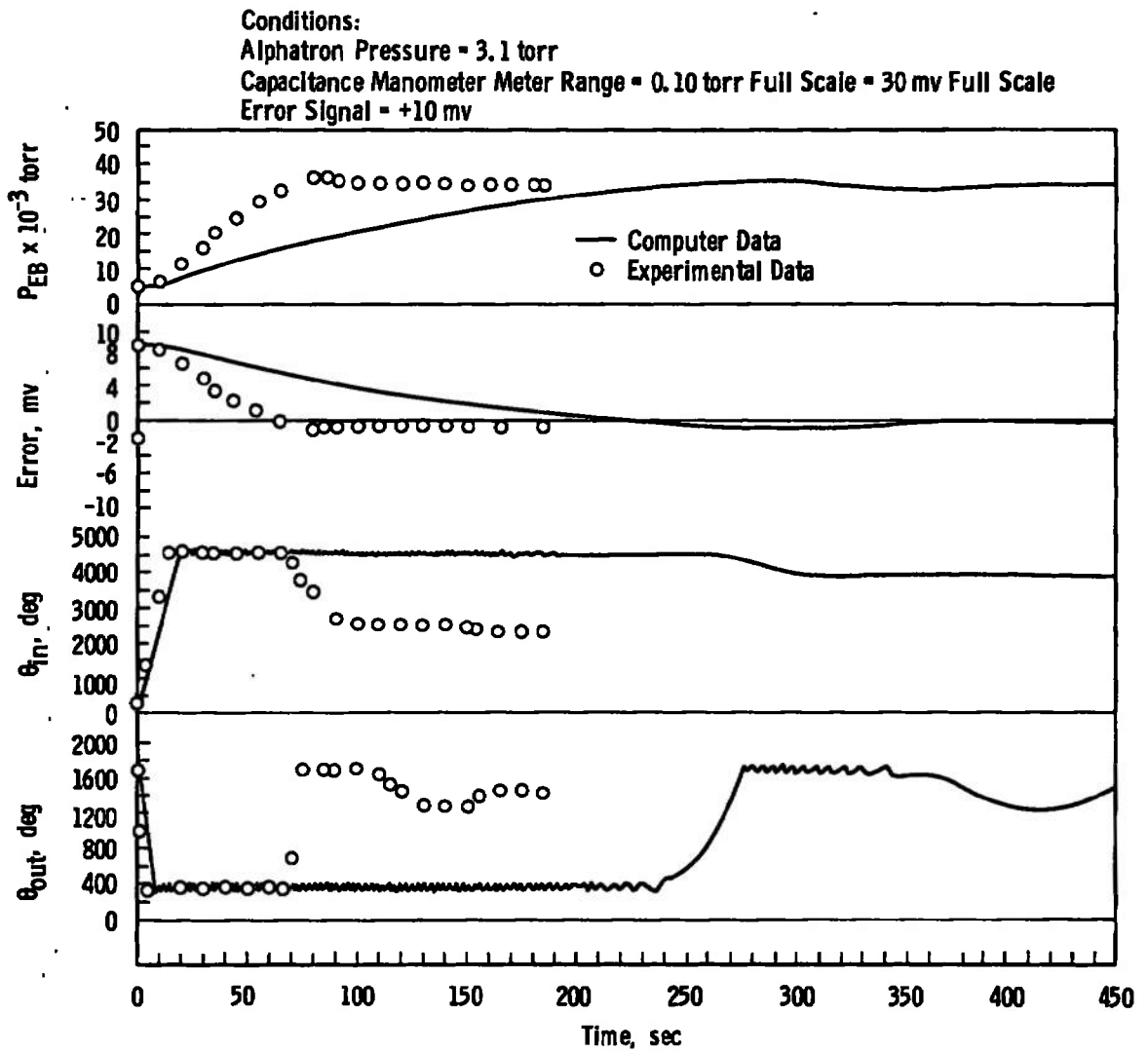

Fig. 13 Transient Response for a Forepressure Set Equal to 3.33×10^{-2} torr

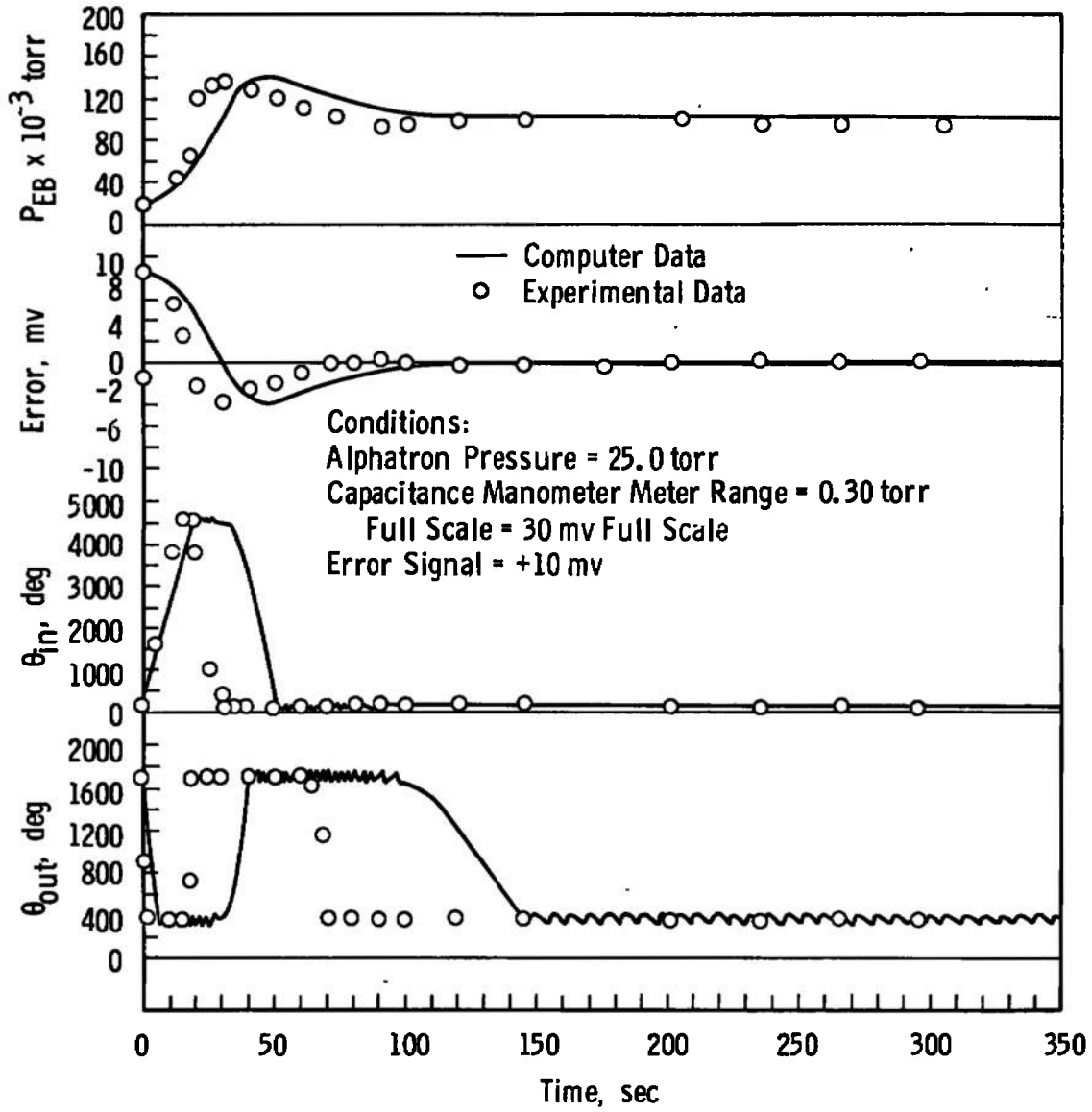

Fig. 14 Transient Response for a Forepressure Set Equal to 1.0×10^{-1} torr

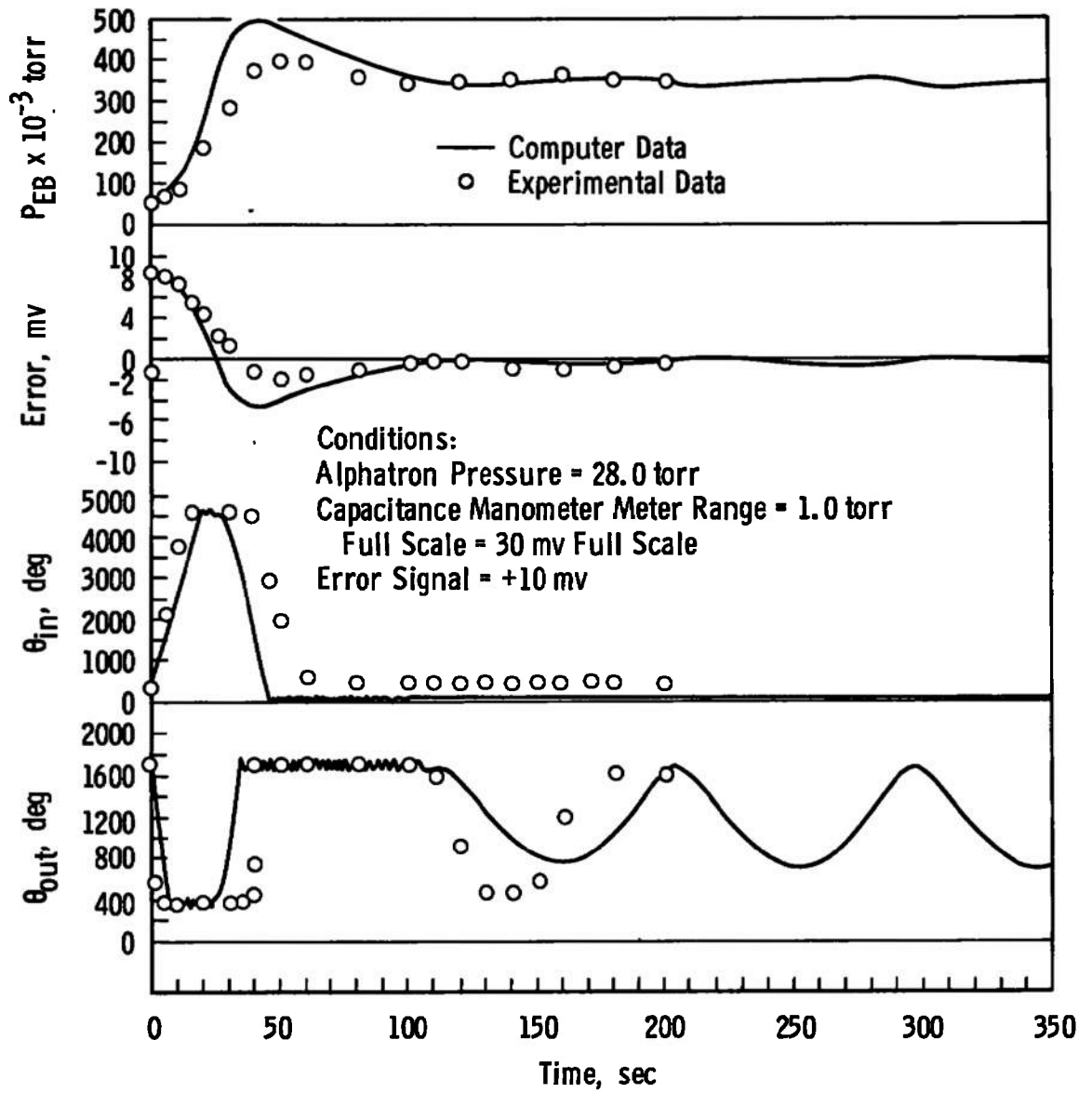

Fig. 15 Transient Response for a Forepressure Set Equal to 3.3×10^{-1} torr

Conditions:
 Alphasatron Pressure = 29.5 torr
 Capacitance Manometer Meter Range = 3.0 torr
 Full Scale = 30 mv Full Scale
 Error Signal = +10 mv

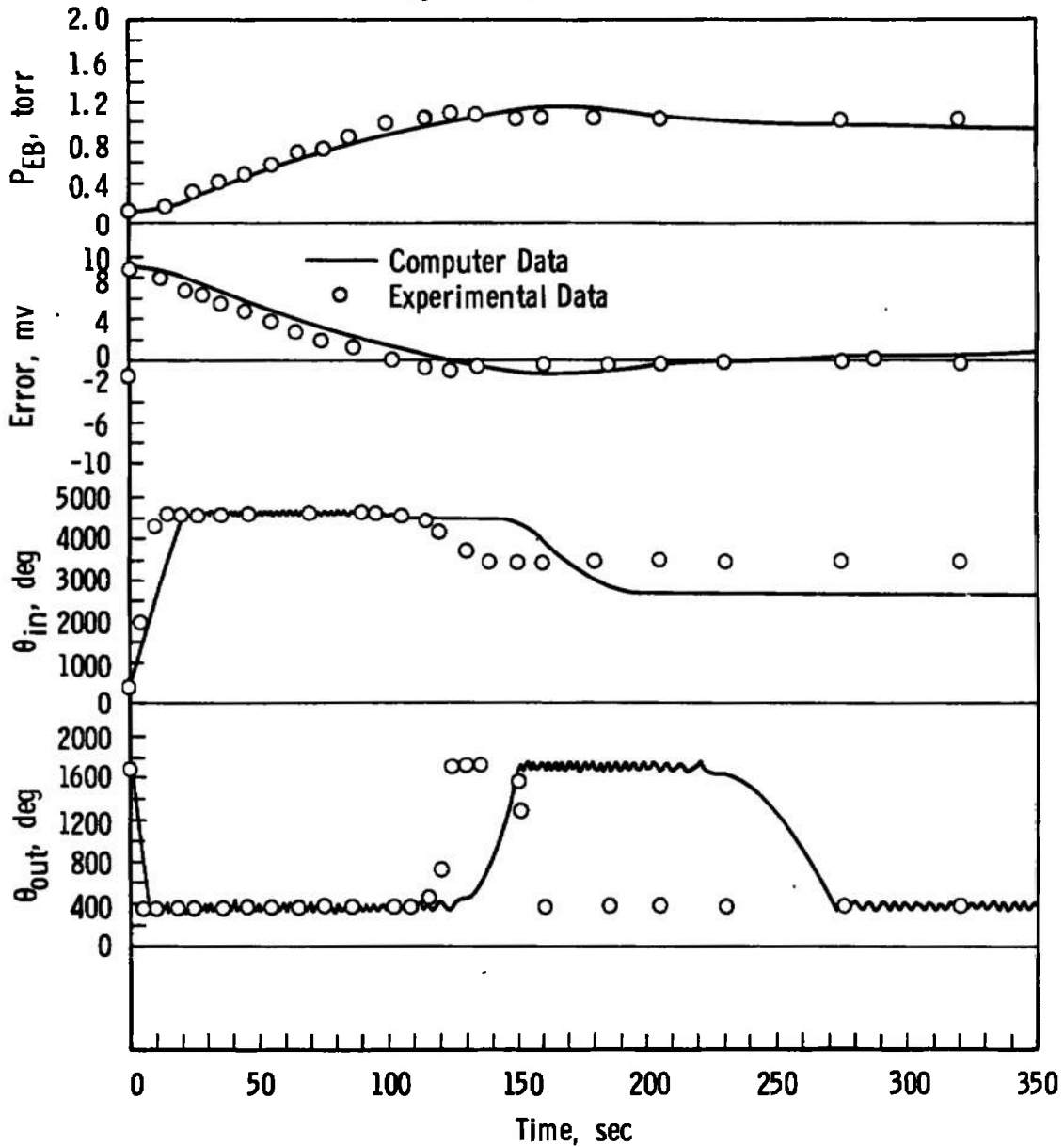

Fig. 16 Transient Response for a Forepressure Set Equal to 1.0 torr

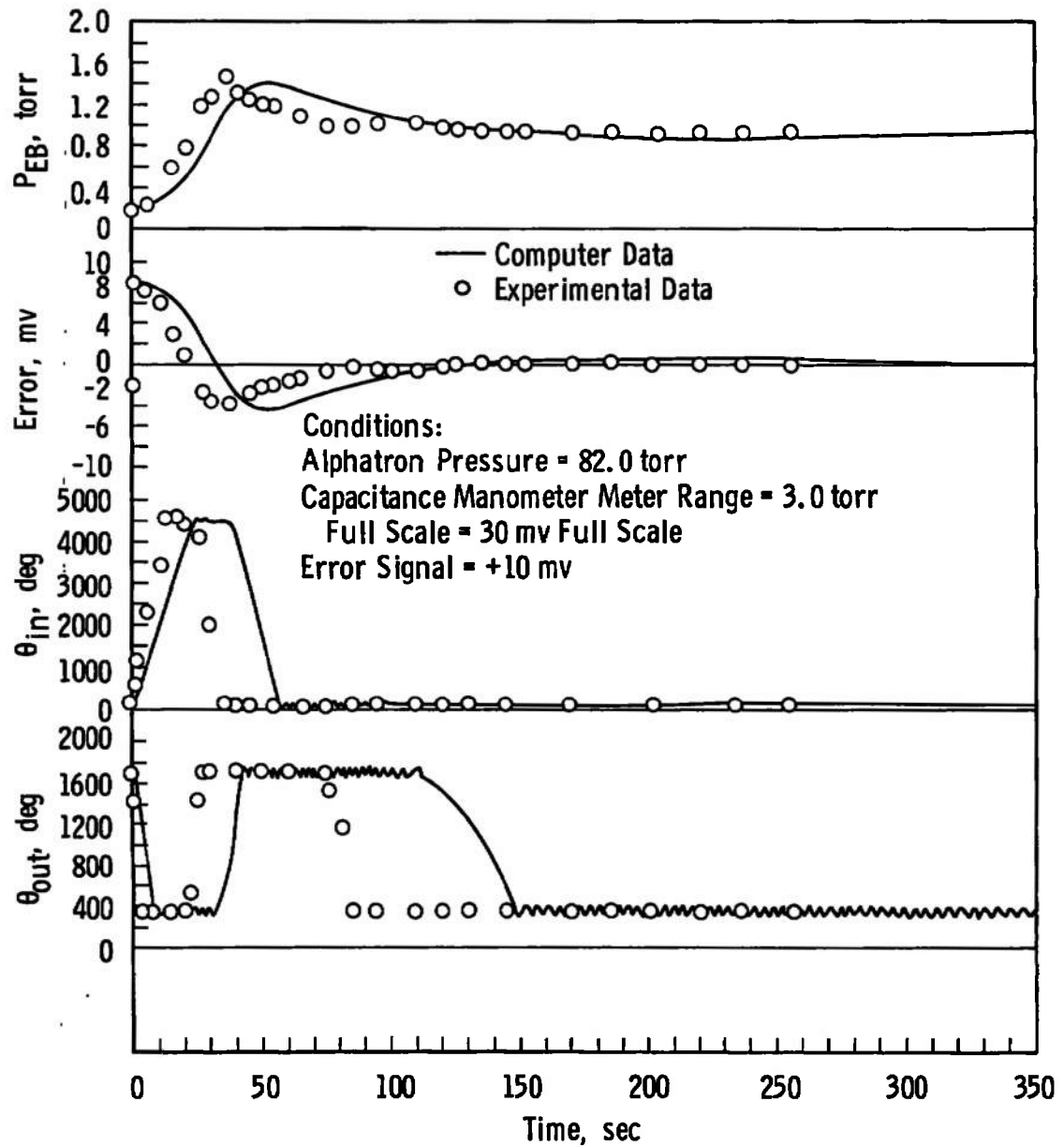

Fig. 17 Transient Response for a Forepressure Set Equal to 1.0 torr

APPENDIX II
SAMPLE CALCULATION FOR THE NUMERICAL VALUES OF C_3

The conductance C_3 of the gas inlet valve as a function of valve shaft angle, θ_{in} , and the Alphasatron pressure, P_a , is given in Fig. 4. The curves were obtained by closing the gas pumpout valve, $C_4 = 0$, and letting the system reach steady state for various valve shaft angles. The conductance C_3 was then calculated from Eq. (8) which is given below.

$$\frac{dP_{EB}}{dT} = \frac{1}{V} [C_3(P_a - P_{EB}) - C_1 P_{EB} - C_4 P_{EB}] \quad (9)$$

Applying the above conditions, Eq. (8) can be reduced to

$$C_3(P_a - P_{EB}) - C_1 P_{EB} = 0 \quad (10)$$

$$C_3 = \frac{C_1 P_{EB}}{P_a - P_{EB}} \quad (11)$$

$C_1 = 6.85 \times 10^{-3}$ liters/sec. The experimental data used to calculate C_3 are given in Table I (Appendix IV).

APPENDIX III
SAMPLE CALCULATION FOR THE NUMERICAL VALUES OF C_4

The conductance C_4 of the gas pumpout valve as a function of valve shaft angle, θ_{out} , and forepressure, P_{EB} , is given in Fig. 5. The pressure downstream of the gas pumpout valve, 2×10^3 torr, is negligible compared to the upstream pressure, that is, the forepressure. These curves were obtained by presetting the inlet valve to give a nominal forepressure. The gas pumpout valve was then opened and the system was allowed to reach steady state for various valve shaft angles. The conductance C_4 was then calculated directly from Eq. (8) which is given below.

$$\frac{dP_{EB}}{dT} = \frac{1}{V} \left[C_3(P_a - P_{EB}) - C_1 P_{EB} - C_4 P_{EB} \right] \quad (12)$$

Applying the above conditions, Eq. (8) can be reduced to

$$C_3(P - P_{EB}) - C_1 P_{EB} - C_4 P_{EB} = 0 \quad (13)$$

$$C_4 = \frac{C_3(P_a - P_{EB}) - C_1 P_{EB}}{P_{EB}} \quad (14)$$

$C_1 = 6.85 \times 10^{-3}$ liters/sec. The experimental data used to calculate C_4 are given in Table II (Appendix IV).

TABLE I
EXPERIMENTAL DATA USED TO CALCULATE C₃

Gas Pumpout Valve	Gas Inlet Valve Stem Position, deg	P _{EB} , torr	P _α , torr	C ₃ , liters/sec
Closed ↓	Closed, 0	0	32	0
	180	0.38	32	6.91 x 10 ⁻⁵
	360	0.40	32	8.68
	540	0.44	33	9.31
	720	0.49	33	1.03 x 10 ⁻⁴
	900	0.53	34	1.08
	1080	0.59	34	1.21
	1260	0.68	34	1.39
	1440	0.74	34	1.52
	1620	0.78	34	1.61
	1800	0.84	34	1.74
	1980	0.93	34	1.93
	2160	0.97	34	2.01
	2520	1.05	34	2.18
	2880	1.13	33	2.42
	3240	1.20	33	2.59
	3600	1.30	32	2.90
	3960	1.45	32	3.26
	4320	1.65	31	3.86
	4680	2.00	29.5	4.99
5040	2.45	27.0	6.83	
5085	2.70	26.0	7.93	

TABLE II
EXPERIMENTAL DATA USED TO CALCULATE C_4

Gas Pumpout Valve, deg	Gas Inlet Valve Stem Position, deg CCW	P_{EB} , torr	P_a , torr	C_3 , liters/sec	C_4 , liters/sec
Closed	1800	14.0	105.0	1.05×10^{-3}	0
180	1800	14.0	105.0	1.05	0
360	1800	14.0	105.0	1.05	0
540	1800	14.0	105.0	1.05	0
720	1800	14.0	105.0	1.05	0
900	1800	14.0	105.0	1.05	0
1080	1800	13.8	105.0	1.05	1.01×10^{-4}
1260	1800	13.6	105.0	1.05	1.98
1440	1800	12.8	105.0	1.05	6.41
1620	1800	12.0	105.0	1.05	1.14×10^{-3}
1800	1800	9.3	105.0	1.05	3.46
1980	1800	6.0	105.0	1.05	9.13
2025	1800	4.0	105.0	1.05	1.71×10^{-2}

DOCUMENT CONTROL DATA - R & D

(Security classification of title, body of abstract and indexing annotation must be entered when the overall report is classified)

1. ORIGINATING ACTIVITY (Corporate author) Arnold Engineering Development Center ARO, Inc., Operating Contractor, Arnold AF Station, Tennessee		2a. REPORT SECURITY CLASSIFICATION UNCLASSIFIED	
		2b. GROUP N/A	
3. REPORT TITLE DESIGN AND DEVELOPMENT OF A SERVOCONTROLLED GAS INBLEED SYSTEM FOR A HIGH VACUUM CALIBRATION CHAMBER			
4. DESCRIPTIVE NOTES (Type of report and inclusive dates) March 1 to September 1, 1967 - Final Report			
5. AUTHOR(S) (First name, middle initial, last name) Albert J. Mathews and Fred M. Shofner, ARO, Inc.			
6. REPORT DATE May 1968	7a. TOTAL NO. OF PAGES 38	7b. NO. OF REFS 3	
8a. CONTRACT OR GRANT NO. AF40(600)-1200		9a. ORIGINATOR'S REPORT NUMBER(S) AEDC-TR-68-100	
b. Program Element 6540215F			
c. Project 4344		9b. OTHER REPORT NO(S) (Any other numbers that may be assigned this report) N/A	
d. Task 434421			
10. DISTRIBUTION STATEMENT This document has been approved for public release and sale; its distribution is unlimited.			
11. SUPPLEMENTARY NOTES Available in DDC.		12. SPONSORING MILITARY ACTIVITY Arnold Engineering Development Center (AETS), Air Force Systems Command, Arnold AF Station, Tennessee	
13. ABSTRACT A servocontrolled gas inbleed system for a dynamic, calibrated conductance type of vacuum calibration system was designed and fabricated. The servocontrolled gas inbleed system automatically regulates the flow of gas into the test region of the calibration system by maintaining a constant pressure on the upstream side of a molecular leak. Constant pressure on the molecular leak is established and maintained by a shunt control technique in which a gas inlet valve and a gas pumpout valve are operated in parallel. An analog computer was used to aid in the design of the system. The transient and steady-state response of the servocontrolled gas inbleed system is predicted by the computer. Good agreement was obtained between the analog computer data and the experimental performance data obtained from the gas inbleed system. The gas inbleed system can control the flow rate in the range from 10^{-5} torr-liters/sec to 10^{-3} torr-liters/sec. Other flow rates are obtainable by changing system components; however, the same design procedure is applicable.			

14. KEY WORDS	LINK A		LINK B		LINK C	
	ROLE	WT	ROLE	WT	ROLE	WT
<u>gas inbleed systems</u> <u>servocontrolled systems</u> transient response steady-state response vacuum calibration systems automatic flow regulation <u>shunt control technique</u>						
3. Gases -- Flow ^{regulation} control						
4. Flow -- Regulation						
6. Vacuum calibration systems						
1-2						