

ESD TR-67-361
ESTI file copy

ESD-TR-67-361

ESD ACCESSION LIST

ESTI Call No. 1 AL 58528

Copy No. 1 of 4 MTR-409 cys.

ESD RECORD COPY

RETURN TO
SCIENTIFIC & TECHNICAL INFORMATION DIVISION
(ENR) BUILDING 1211

INTRA-STATION DATA TRANSMISSION ENGINEERING

SEPTEMBER 1967

O. Cardinale

W. J. Ciesluk, Jr.

ESSI

1 of 2

Prepared for
DEPUTY FOR SURVEILLANCE AND CONTROL SYSTEMS
AEROSPACE INSTRUMENTATION PROGRAM OFFICE
ELECTRONIC SYSTEMS DIVISION
AIR FORCE SYSTEMS COMMAND
UNITED STATES AIR FORCE
L. G. Hanscom Field, Bedford, Massachusetts



This document has been approved for public release and sale; its distribution is unlimited.

Project 705B
Prepared by
THE MITRE CORPORATION
Bedford, Massachusetts
Contract AF19(628)-5165

ADU 662002

When US Government drawings, specifications, or other data are used for any purpose other than a definitely related government procurement operation, the government thereby incurs no responsibility nor any obligation whatsoever, and the fact that the government may have formulated, furnished, or in any way supplied the said drawings, specifications, or other data is not to be regarded by implication or otherwise, as in any manner licensing the holder or any other person or corporation, or conveying any rights or permission to manufacture, use, or sell any patented invention that may in any way be related thereto.

Do not return this copy. Retain or destroy.

NRD INTRA-STATION DATA TRANSMISSION ENGINEERING

SEPTEMBER 1967

O. Cardinale

W. J. Ciesluk, Jr.

Prepared for
DEPUTY FOR SURVEILLANCE AND CONTROL SYSTEMS
AEROSPACE INSTRUMENTATION PROGRAM OFFICE
ELECTRONIC SYSTEMS DIVISION
AIR FORCE SYSTEMS COMMAND
UNITED STATES AIR FORCE
L. G. Hanscom Field, Bedford, Massachusetts



This document has been approved for public release and sale; its distribution is unlimited.

Project 705B
Prepared by
THE MITRE CORPORATION
Bedford, Massachusetts
Contract AF19(628)-5165

FOREWORD

This report was prepared by the Range Communications Planning Technology Subdepartment of The MITRE Corporation, Bedford, Massachusetts, under Contract AF 19(628)-5165. The work was directed by the Development Engineering Division under the Aerospace Instrumentation Program Office, Air Force Electronics Systems Division, Laurence G. Hanscom Field, Bedford, Massachusetts. Captain J. J. Centofanti served as the Air Force Project Monitor for this program, identifiable as ESD (ESSI) Project 5932, Range Digital Data Transmission Improvement.

REVIEW AND APPROVAL

Publication of this technical report does not constitute Air Force approval of the report's findings or conclusions. It is published only for the exchange and stimulation of ideas.

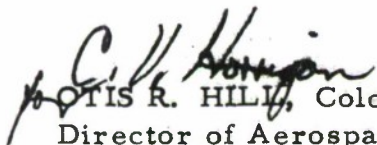
OTIS R. HILL, Colonel, USAF
Director of Aerospace Instrumentation
Program Office

ABSTRACT

Methods for transferring digital data between remote subscribers and Range Communications Control Centers within NRD sites are reviewed and baseband data transmission techniques for this purpose are examined in detail. First, the factors which influence baseband data transmission in existing NRD intra-site cable pairs are discussed. Next, a test program, which was designed to measure the transmission characteristics and the error rate performance of some simple baseband data techniques over these cable pairs, is described and the results are presented, analyzed, and interpreted. Finally, the elements which require special consideration in the design of efficient, cost effective baseband systems for intra-station data transmission are stressed and some implementation suggestions are presented.

TABLE OF CONTENTS

		<u>Page</u>
LIST OF ILLUSTRATIONS		vi
LIST OF TABLES		vii
SECTION I	INTRODUCTION	1
	Background	1
	Intra-Station Data Transmission Considerations	1
	Distribution of Circuits	2
	Environmental Conditions	2
	Available Techniques for Data Transfer	6
	Cost Considerations	7
SECTION II	BASEBAND DATA TRANSMISSION CONSIDERATIONS	9
	Ideal Baseband Data Transmission	9
	Transmission Impairments	10
	Noise, Crosstalk, and RFI	11
	Mismatch	13
	Timing/Synchronization Errors	13
SECTION III	MEASUREMENTS PROGRAM	14
	Description of the Tests	14
	Description of the Test Results	22
	Signal Transmission Characteristics	24
	Error Rate Performance	31
SECTION IV	ANALYSIS AND INTERPRETATION OF RESULTS	34
	Present NRD Multi-pair Circuits	34
	Expected Performance	34
	Simulation Tests for Multi-pair Circuits	35
SECTION V	SYSTEMS APPLICATIONS CONSIDERATIONS	44
	Possible Configurations	44
	Matching	44
	Synchronization	44
	Noise Rejection	47
	Cost Effectiveness Considerations	49
SECTION VI	SUMMARY	54
SECTION VII	CONCLUSIONS	55
REFERENCES		57

LIST OF ILLUSTRATIONS

<u>Figure</u>		<u>Page</u>
1	Estimated Distribution of Intra-Site Data Link Lengths on the Eastern Test Range	3
2	Estimated Distribution of Intra-Site Data Link Lengths on the Western Test Range	4
3	Typical Intra-Site Data Link Configuration	5
4	Implementation of Common Mode Rejection	12
5	Measurements Program Test Console	16
6	Carrier Modulation Test Configuration (Configuration A)	18
7	Polar NRZ Test Configuration (Configuration B)	19
8	Bipolar NRZ Test Configuration (Configuration C)	20
9	Modem Keying Test Configuration (Configuration D)	21
10	Polar NRZ Signal Transmitted at 2400 Bits/Second over a $\frac{1}{2}$ Mile 22 AWG Non-Loaded Line	25
11	Polar NRZ Signal Transmitted at 2400 Bits/Second over a 1 Mile 22 AWG Non-Loaded Line	25
12	Polar NRZ Signal Transmitted at 2400 Bits/Second over a 1 Mile 22 AWG Non-Loaded Line - Expanded Time Scale	26
13	Polar NRZ Signal Transmitted at 2400 Bits/Second over a 2 Mile 22 AWG Non-Loaded Line	26
14	Polar NRZ Signal Transmitted at 2400 Bits/Second over a 3 Mile 22 AWG Non-Loaded Line	27
15	Polar NRZ Signal Transmitted at 2400 Bits/Second over a 5 Mile 19 AWG Non-Loaded Line	27
16	Polar NRZ Signal Transmitted at 2400 Bits/Second over a 7 Mile 16 PSVL Wideband Video Line	28
17	Bipolar NRZ Signal Transmitted at 2400 Bits/ Second over a $\frac{1}{2}$ Mile 22 AWG Non-Loaded Line	28
18	Bipolar NRZ Signal Transmitted at 2400 Bits/ Second over a 1 Mile 22 AWG Non-Loaded Line	29
19	Bipolar NRZ Signal Transmitted at 2400 Bits/ Second over a 1 Mile 22 AWG Non-Loaded Line - Expanded Time Scale	29
20	Bipolar NRZ Signal Transmitted at 2400 Bits/ Second over a 5 Mile 19 AWG Non-Loaded Line	30
21	Polar NRZ Signal Transmitted at 2400 Bits/ Second over a Simulated 2500 Foot 22 AWG Non-Loaded Line	37
22	Polar NRZ Signal Transmitted at 4800 Bits/ Second over a Simulated 2500 Foot 22 AWG Non-Loaded Line	37

LIST OF ILLUSTRATIONS (CONT)

<u>Figure</u>		<u>Page</u>
23	Polar NRZ Signal Transmitted at 2400 Bits/ Second over a Simulated 5250 Foot 22 AWG Non-Loaded Line	38
24	Polar NRZ Signal Transmitted at 4800 Bits/ Second over a Simulated 5250 Foot 22 AWG Non-Loaded Line	38
25	Polar NRZ Signal Transmitted at 2400 Bits/ Second over a Simulated 10,500 Foot 22 AWG Non-Loaded Line	39
26	Polar NRZ Signal Transmitted at 4800 Bits/ Second over a Simulated 10,500 Foot 22 AWG Non-Loaded Line	39
27	Polar NRZ Signal Transmitted at 2400 Bits/ Second over a Simulated 15,750 Foot 22 AWG Non-Loaded Line	40
28	Polar NRZ Signal Transmitted at 4800 Bits/ Second over a Simulated 15,750 Foot 22 AWG Non-Loaded Line	40
29	Polar NRZ Signal Transmitted at 2400 Bits/ Second over a Simulated 21,000 Foot 22 AWG Non-Loaded Line	41
30	Polar NRZ Signal Transmitted at 4800 Bits/ Second over a Simulated 21,000 Foot 22 AWG Non-Loaded Line	41
31	Polar NRZ Signal Transmitted at 2400 Bits/ Second over a Simulated 26,500 Foot 22 AWG Non-Loaded Line	42
32	Polar NRZ Signal Transmitted at 4800 Bits/ Second over a Simulated 26,500 Foot 22 AWG Non-Loaded Line	42
33	Polar NRZ Signal Transmitted at 300 Bits/ Second over a Simulated 26,500 Foot 22 AWG Non-Loaded Line	43
34	Polar NRZ Signal Transmitted at 300 Bits/ Second over a Simulated 26,500 Foot 22 AWG Non-Loaded Line - 12 Consecutive Marks	43
35	Preferred Intra-Site Baseband Data Communi- cations System Configuration	45
36	Alternate Intra-Site Baseband Data Communi- cations System Configuration	46
37	Common Mode Rejection Test Configuration	48
38	Intra-Site Data Transmission Cost Analysis	51

LIST OF TABLES

<u>Table Number</u>		<u>Page</u>
I	Maximum Theoretical Transmission Range for Polar NRZ Data Over NRD Intra-Site Lines Without Repeaters	10
II	Typical Parameters of 22 AWG, 19 AWG Non- Loaded and 16 PSVL Cables	23
III	Summary of Error Rate Performance Test Results	32

SECTION I

INTRODUCTION

Background

Centralizing the location of long haul data transmission circuit modems into Range Communication Control Centers has been adopted as a standard policy for the Eastern and Western Test Ranges by the National Range Division of the Air Force Systems Command. In the past, these modems have been located at individual subscriber stations as needed. The result of this has been operation of dedicated transmission type facilities which are not operationally efficient unless on the average there is a high time-utilization factor for these facilities. The new Range Data Transmission System operational policy is to establish maximum use of common user facilities for the system.

The advantages of common user transmission facilities are more efficient utilization of data transmission facilities, as well as flexibility of operation, and ease of maintenance. However, a consequence of this policy is the need to transfer data from the subscriber terminals to the station Communication Control Center. If the same class of modems are required to transfer this data over these tail segment links (i.e. subscriber terminal to communication center links) then the original concept of common user operation has been seriously compromised. Thus this policy of common user operation is dependent on methods of data transfer over these tail segment links that provides performance which is compatible with the overall link performance requirements and has an implementation which is much less complex and an order of magnitude less costly than the present modems. This paper addresses itself to the problem of available methods for achieving this goal, and an engineering description of the problems involved.

Intra-Station Data Transmission Considerations

There are two general methods available to transfer digital data over intra-station or tail segment links. These are the following:

- 1) Baseband data transmission
- 2) Carrier data transmission

Baseband data transmission is defined as the transfer of digital data over various types of wire pairs used on the Eastern and Western Test Ranges which include #19 AWG, #22 AWG (both in individual or multipair type cable) and shielded video pair cable such as 16 PSVL. These types are extensively used by NRD-DTS facilities. Where required, regenerative repeaters may be used in this implementation; however, no carrier type data regeneration is permissible (by definition).

Carrier data transmission requires the use of modem devices to achieve data transmission and regeneration. An important constraint on this type of transmission (and baseband as well) is the requirement that tail segments data transmission performance shall not be significantly degraded relative to the main long haul circuit link performance level (i.e. shall be at least an order of magnitude less).

Distribution of Circuits

The approximate cumulative distribution of tail segment links for the Eastern Test Range is shown in Figure 1.* This shows the relative distribution (in percent) of the various wire pair lengths located at each of the range stations. Note that approximately 90% of these links are less than three miles in length. (Cable length is used here rather than line of sight distances.) The cumulative (approximate) distribution of tail segment links for the Western Test Range is shown in Figure 2.* In this case there is a larger distribution of the longer paths. This is due primarily to the rugged terrain and geographic spread of sites on the WTR. In the following sections of this report, these distributions will be used for cost effectiveness analysis purposes to establish the relative utilization levels for baseband vs. carrier data transmission.

Environmental Conditions

Existing cable plant facilities are examined for both the WTR and ETR. Figure 3 shows the typical implementation of wire intra-site data links. The cables are generally direct burial types which minimizes external interference problems.

*Based on sampling of typical intra-station link lengths at Cape Kennedy and Vandenberg Air Force Base.

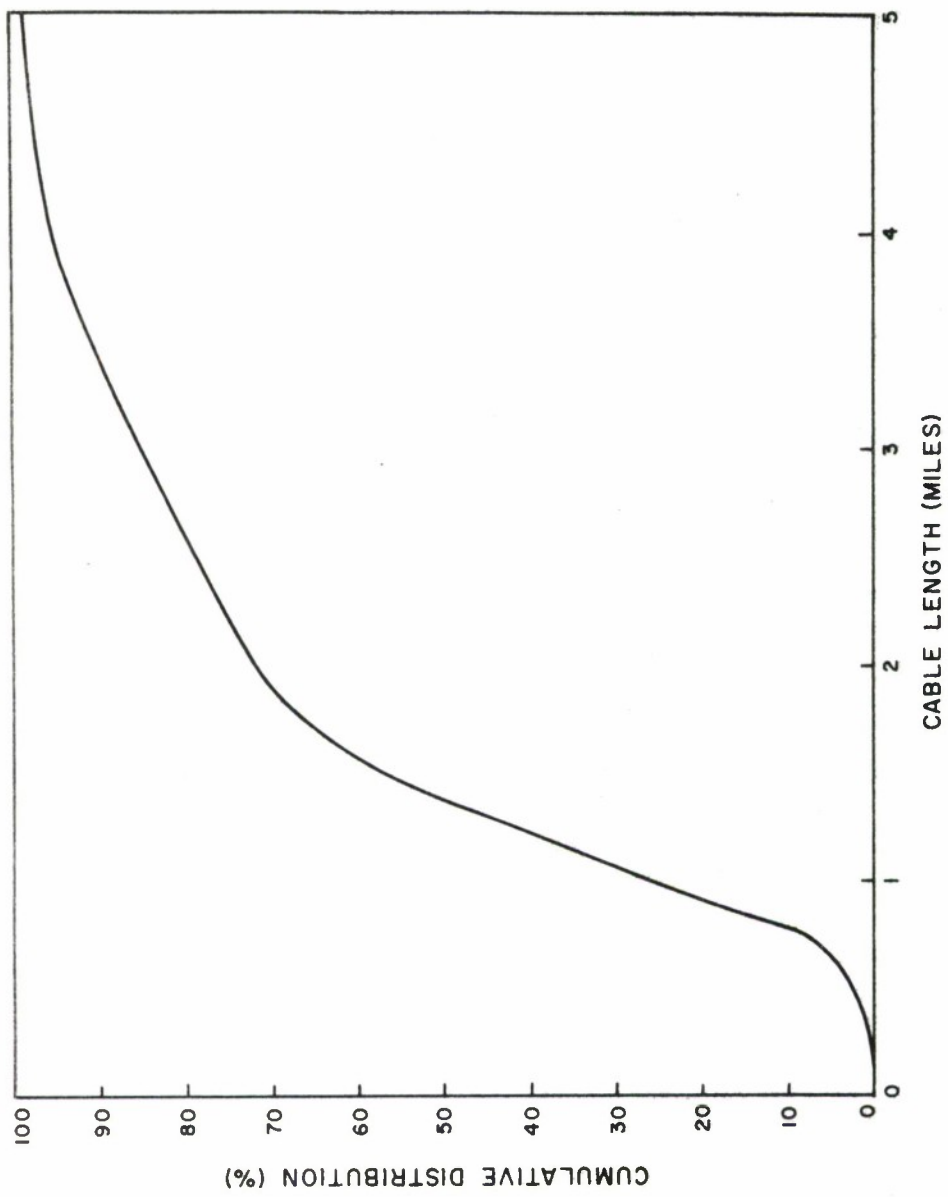

Figure 1 ESTIMATED DISTRIBUTION OF INTRA-SITE DATA LINK LENGTHS ON THE EASTERN TEST RANGE

IA-21,636

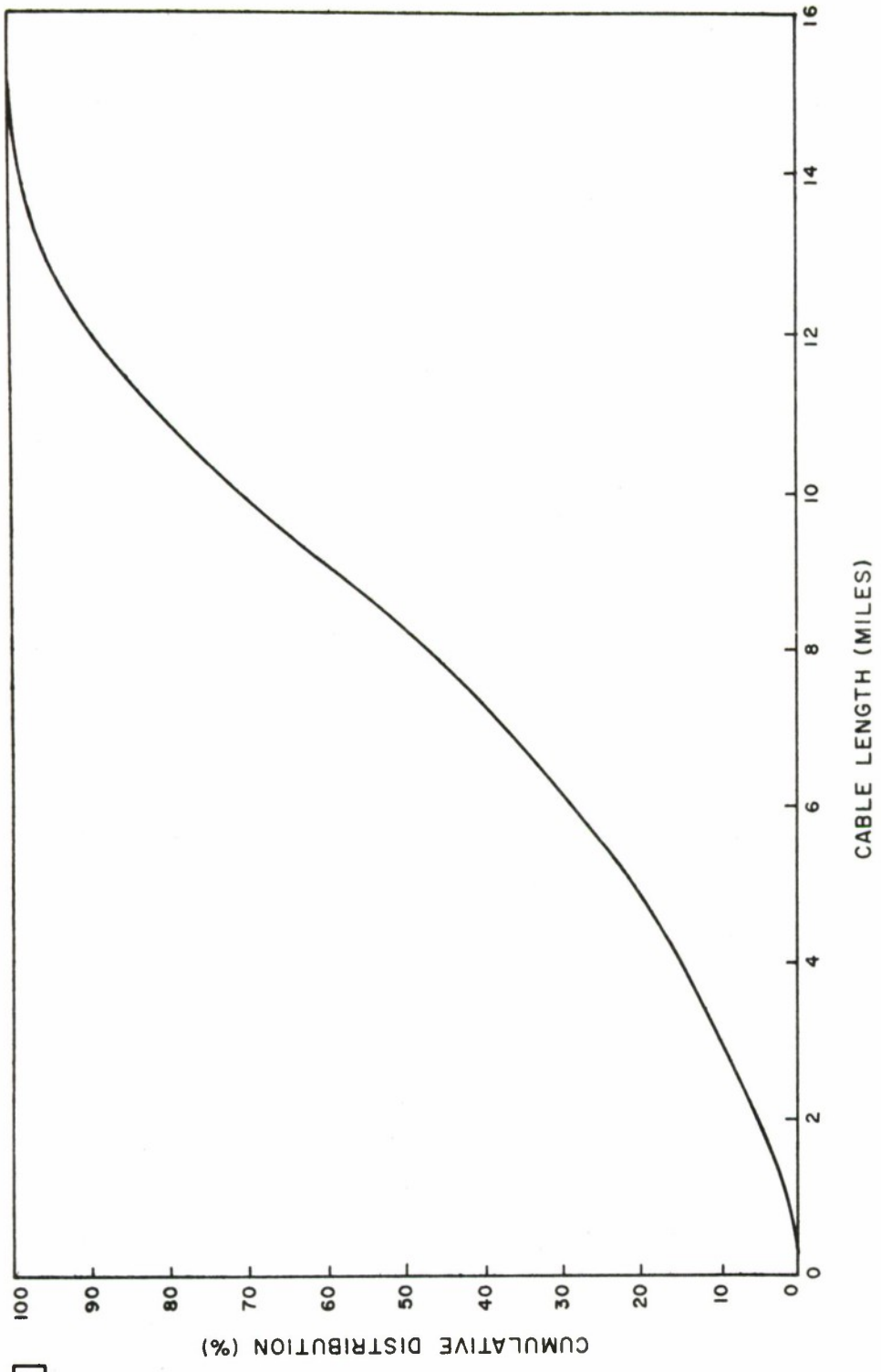

Figure 2 ESTIMATED DISTRIBUTION OF INTRA-SITE DATA LINK LENGTHS ON THE WESTERN TEST RANGE

IA-21,637

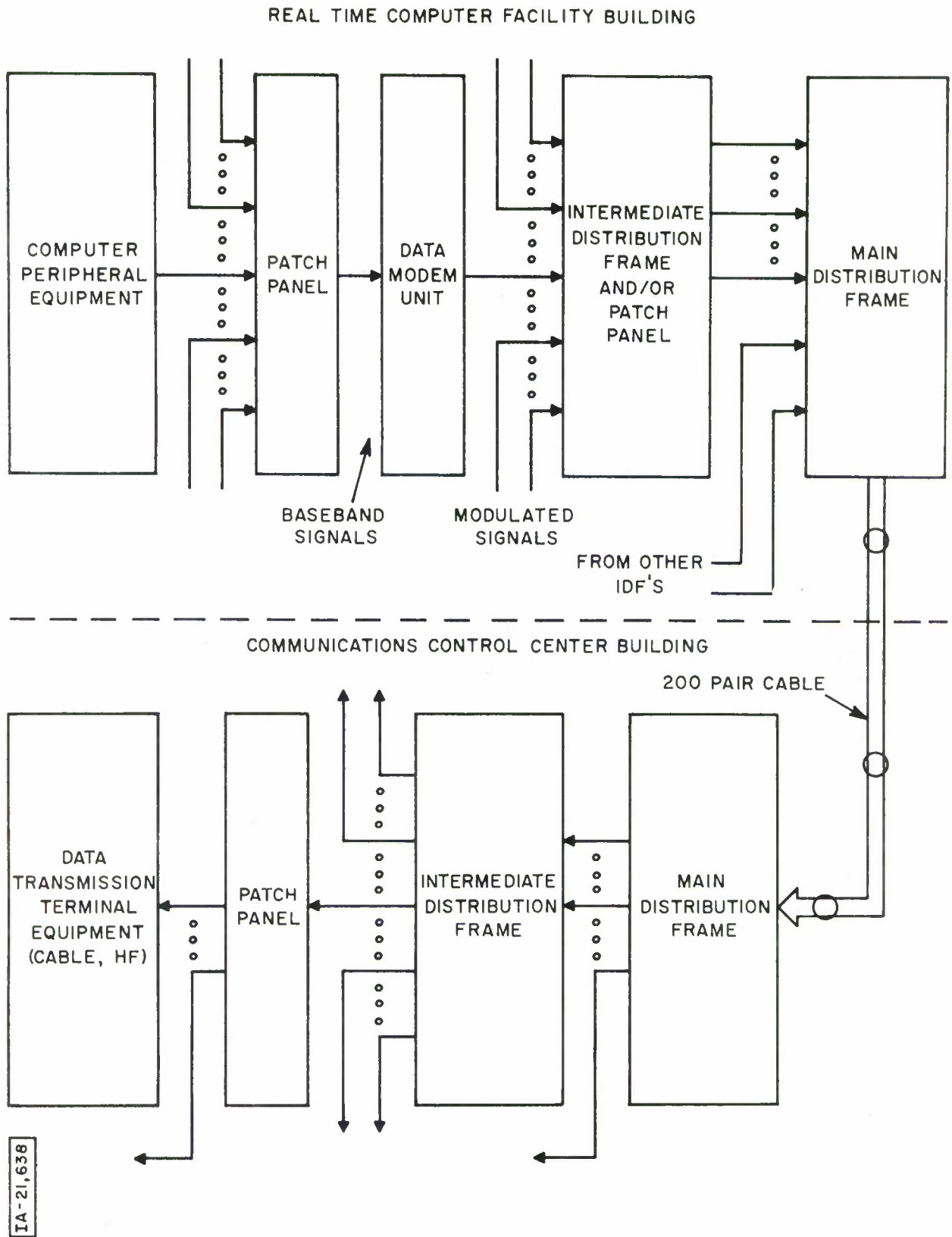

Figure 3 TYPICAL INTRA-STATION DATA LINK CONFIGURATION

However, there are several locations where this is not practical so that overhead cable distribution is used. One example of this situation is Ascension Island, where the soil is predominantly volcanic. Unfortunately, a high level RFI problem also exists on the island; there is a multi-megawatt BBC broadcast station and several high power radars in operation. Any system which uses these cables, whether it is carrier or baseband, must contend with this environment.

Near end and far end crosstalk is another environmental factor to be considered. Teletype, voice and other analogue data signals are generally found to be sharing the same common multipair cable link with baseband data. Teletype data signal levels can be as much as 60 ma current pulses, whereas voice and analog data signals are limited to peak levels of less than +4 dbm. (See Reference 1)

Available Techniques for Data Transfer

It was stated in the previous section of this paper that there are two basic implementations available, i.e. carrier, and baseband data transmission. For the latter implementation the following subclasses are considered here:

- 1) #22 AWG wire pairs
- 2) #19 AWG wire pairs
- 3) #16 PSVL/PEVL shielded video pairs

In addition, there are the following variations for each of these implementations:

- 1) Existing cable plant, without modifications.
- 2) Existing cable plant, using repeaters.
- 3) New cable plant with resistive terminations.
- 4) New cable plant with signal repeaters.

- 5) New cable plant with matched termination for line characteristic impedance Z_0 (as a function of frequency).
- 6) New cable plant with repeaters and matched terminations.

Each of these implementations will provide increasing improved performance in the same order as they are given below.

Insofar as carrier techniques are concerned, there are two basic approaches to be taken. The common approach is to use wireline modem data transmission. Another approach that can be used is the carrier channel deriving equipment method. Here, the baseband signals for several subscriber sources may be multiplexed (frequency) onto a single wire pair to the communication center. This latter approach would only be used for the cases where a large number of data subscriber sources were in the same location and were all routed to the Communication Control Center, otherwise such an approach is not considered to be economical. Further consideration will not be given to this implementation here.

Cost Considerations

Before any particular implementation for tail segment data transmission can be considered, it is necessary to review the relative costs involved as well as the performance gained. The following data* is given as a guide:

- 1) #22 AWG \$1.10/ft. - 200 pair cable
- 2) #22 AWG \$0.26/ft. - 26 pair cable
- 3) #19 AWG \$2.00/ft. - 200 pair cable
- 4) #19 AWG \$0.35/ft. - 26 pair cable
- 5) #16 PEVL \$0.217/ft. - single shield video pair

* Based on GEEIA sources.

6) Modem A - \$10,000 (Initial cost only)

7) Modem B - \$ 6,000 (Initial cost only)

The estimated costs for implementing tail segment links will be analyzed in Section V of this report, (after the various implementations have been described and analyzed). The overall problem then is to develop a rationale for tail segment data link implementations which are based on overall transmission link requirements, and are cost effective. No single implementation will be proposed to meet all needs; rather a class of implementations will be developed to meet these tail segment transmission requirements as needed.

SECTION II

BASEBAND DATA TRANSMISSION CONSIDERATIONS

Presently, the data subscribers on the ETR are connected by multipair telephone cable consisting of 200 unshielded wire pairs (#19 AWG or #22 AWG) per cable and 12 individually shielded (16 PSVL) video pairs. Splices for multi-access to these cables and other installation practices which cause mismatch are common. The standard data rates used by the subscribers are 300, 600, 1200 and 2400 bits/second. The military standards (MIL-STD-188B) require that this data source supply polar NRZ at ± 0.6 volts and that the data receiver be capable of operating reliably with an input signal whose center sampled amplitude* is greater than ± 0.5 volt. The present investigation was initiated to determine the suitability of existing intra-site cable plant for baseband data transmission without the use of repeaters or equalizers.

Ideal Baseband Data Transmission

First some theoretical calculations were made to determine the bounds on transmission range over the available types of cable for the standard data rates, and interface constraints. The transmission range bound was selected as the length of matched cable over which a ± 6 volt polar NRZ signal would be received with a center sampled peak amplitude of 0.5 volt.

The non-inductive, leakage free transmission line model is a good representation of 22 AWG and 19 AWG nonloaded pairs. The pulse response of a matched line of this type was first solved by Lord Kelvin to determine the practicability of a transoceanic cable and is solved in Goldman² using transformation calculus. The response of this cable to a unit pulse of width T at a distance x from the sending is

$$e(x,t) = \operatorname{erfc} \sqrt{\frac{x^2}{4t} RC} \quad U(t) - \operatorname{erfc} \sqrt{\frac{x^2}{4(t-T)} RC} \quad U(t-T)$$

* Signal amplitude at middle of input bit period.

and the pulse rise time t_r is approximately equal to $\sqrt{RC}/4$ where "R" and "C" are the resistance and capacitance per unit length. This model was used to compute the transmission range bound for both 22 and 19 AWG non-loaded lines using handbook parameters.³ The results are presented in Table I for both 2400 and 4800 bits/second.

The 16 PSVL video cable is a specially designed cable in which an attempt has been made to obtain an ideal transmission characteristic over a large frequency band. It is not easily represented by a transmission line model, but pulse attenuation of this line can be approximated by the attenuation at the fundamental frequency of the pulse train. Since the cable was designed for a video bandwidth of 4 MHz, the attenuation rather than rise time should be limiting factor for data rates up to 4800 bps. Using these approximations, the transmission range bound on the video cable was computed to be 25 miles at 2400 bps, using tabulated characteristics of the 16 PSVL cable.⁴ The results are also presented in Table I for both 2400 and 4800 bits/ second.

TABLE I

Maximum Theoretical Transmission Range for Polar NRZ
Data over NRD Intra-site Lines without Repeaters

Data Rate	Types of Line		
	22 AWG	19 AWG	16 PSVL
2400 B/S	11 Miles	18 Miles	25 Miles
4800 B/S	8 Miles	13 Miles	20 Miles

Transmission Impairments

There are several conditions which exist in actual multi-conductor pair circuits which may prevent the realization of reliable transmission over cable lengths listed in Table I. However, with careful engineering, the effects of these can be decreased substantially. These impairments are discussed below.

Noise, Crosstalk and RFI

These additive effects can hinder baseband data transmission if they are present with substantial power to cause incorrect recognition of the bits. The signal constraints imposed above were selected so that adequate protection against thermal noise would exist so that it will be negligible for this application. In addition, impulse noise should be negligible because of the presence of minimum switching in the network before detection.

However, crosstalk and interference from other external sources (eg RFI) could be significant especially in the unshielded multiconductor pairs where no attempt is made to segregate the high level teletype sources from the low level data sources.

Two types of crosstalk can be differentiated in multiconductor cables, namely near end and far end. The near end crosstalk effect occurs when a multi-pair cable is used for two way transmission in which several input and output signal inputs cause interference in adjacent low level signal output lines. The near end crosstalk levels obviously are independent of the line length.

On the other hand, far end crosstalk levels are due to cumulative capacitive coupling to adjacent pairs along the length of the line and therefore these levels increase with line length. For the short lines (less than one mile) used for intra-range transmission, near end effects will most likely be the predominant crosstalk interference.

Crosstalk and other external source induced noise can be reduced substantially by using a common mode rejection line configuration as shown in Figure 4. In this configuration, voltage from an external source is equally induced in each line and flow in opposite phase at the load end canceling each other. The degree of rejection obtained is a function of the degree of electrical balance achieved. At the lower frequency bands rejection of 60 db or more are easily obtained. If additional protection is required, individually shielded pairs can be used in addition to common mode rejection.

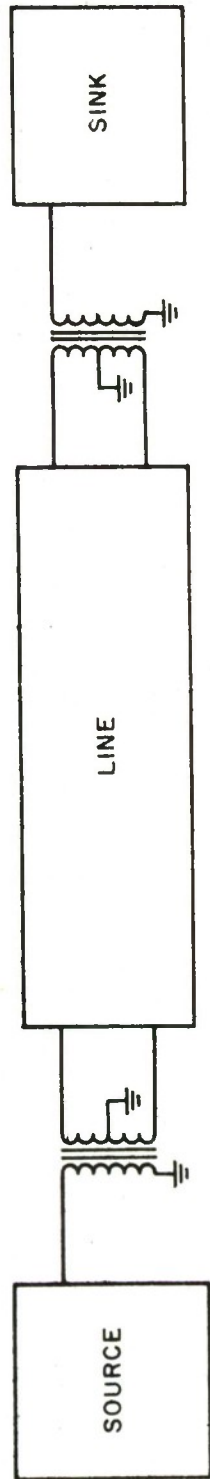

Figure 4. AN IMPLEMENTATION OF COMMON MODE REJECTION

Mismatch

As already pointed out, splices for multi-access to the NRD multi-pair cables and other installation practices which cause mismatch are common occurrences. These conditions can produce loading conditions which increase the attenuation and/or decrease the bandwidth of the multi-pair circuits. In addition, radiation from the vicinity of the line ends due to mismatch can cause crosstalk into the other pairs. For short links, these mismatches can be tolerated with no significant degradation of performance. However, to achieve baseband data transmission over extended cable lengths, some degree of matching is required. Matching of the existing cable plant may be difficult, but new links can be constructed with clean pairs and good matching.

Timing/Synchronization Errors

The baseband data transmission system must be synchronous to be integrated into the present NRD data system. This means that the data clock must be derived from the data or more desirably must be transmitted from a clock source. In either case timing errors can be introduced which will reduce the signal margin against interference in the line. These effects are not easily evaluated theoretically, but can be checked experimentally to be sure that the system performs reliably.

SECTION III

MEASUREMENTS PROGRAM

As a preliminary investigation of the NRD intra-site baseband data transmission, a measurement program was designed to measure the channel transmission characteristics of some existing ETR intra-station cable pairs and the error rate performance of some simple baseband data transmission techniques over these pairs. In this program the signal levels were restricted to +4 dbm (≈ 2.5 volts) as suggested by telephone practice to prevent interference with operational traffic in the same cable system. In addition, no attempt to decrease the degree of mismatch was made, but balanced circuits were used to decrease the effects of crosstalk and RFI.

The three signaling techniques selected for comparison were carrier modulation, baseband polar NRZ (present interface signal) and a bipolar NRZ technique.

The wireline modem which was used in this test was the AN/GSC-20. It is a four level time differential PSK system which uses 4 phase shift keyed tones to achieve data transmission rates up to 2400 b/s. The tones are spaced 600 Hz apart beginning at 900 Hz and ending at 2700 Hz. Each tone channel is keyed at 300 symbols per second (2 bits/symbol) resulting in a transmitted symbol duration of 3 1/3 milliseconds.

The bipolar NRZ technique has been included since it should be less susceptible to teletype cross-talk than the polar NRZ (because of the relative separation of this signal spectrum from TTY signal spectrum). The bipolar signal is essentially an ON-OFF signal in which the polarity of alternate ON signals is reversed. The signal generated in such a manner has a power spectrum with peaks at a frequency equal to one half the signaling rate and with zeros at DC and at a frequency equal to the signaling rate. Thus, the spectrum peak of the bipolar NRZ signal is not coincident with the peak of the teletype spectrum and should be more immune to crosstalk than the polar NRZ signal.

Description of the Tests

The proposed test program was detailed in MITRE WP-941⁽¹⁾. In this program, the relative performance of the three data transmission techniques just discussed was to be measured at a data rate of 2400 b/sec over multi-conductor cable wireline channels of various lengths in a typical operational environment. These three techniques were to

be operated simultaneously over three parallel channels in the same cable and the errors occurring in each were to be automatically detected and recorded. In addition, the measurable transmission characteristics such as pulse rise time, sag, and attenuation were to be observed. The test configuration is shown in Figure 5.

The channel lengths which were proposed in the tests were approximately 1/2, 1 and 5 miles. The channels were formed as loops such that each channel originated at the MDF (Main Distribution Frame) of the Cape Kennedy Communications Control Center (XY Bldg.) looped through the MDF of the remote data subscriber and terminated with the nominal characteristic impedance of the line back at the MDF of the Communications Control Center. Channels with high crosstalk levels were to be chosen.

Each test was to be run for the same 8 hour period of each day to minimize the effects of crosstalk level variations from test to test. In addition, the signal to crosstalk level in each channel was to be made equal.

Since the measured crosstalk levels on the intra-site cables used for these tests were found to be insignificant when connected in the balanced mode during normal and heavy operational traffic periods, some of the original test constraints were relaxed, namely:

- 1) Each test did not have to be conducted during the same 8 hour period of each day.
- 2) The signal levels to each channel were made equal.
- 3) The three techniques no longer needed to be tested simultaneously and the time for each test could be reduced to less than 8 hours.

At the same time, the following additions were made to the original test plan:

- 1) Tests were conducted at 2 and 3 miles since sufficient bandwidth was not available on the 5 mile path.
- 2) The polar NRZ signal was transmitted over various lengths of line in tandem with the modem terminal.

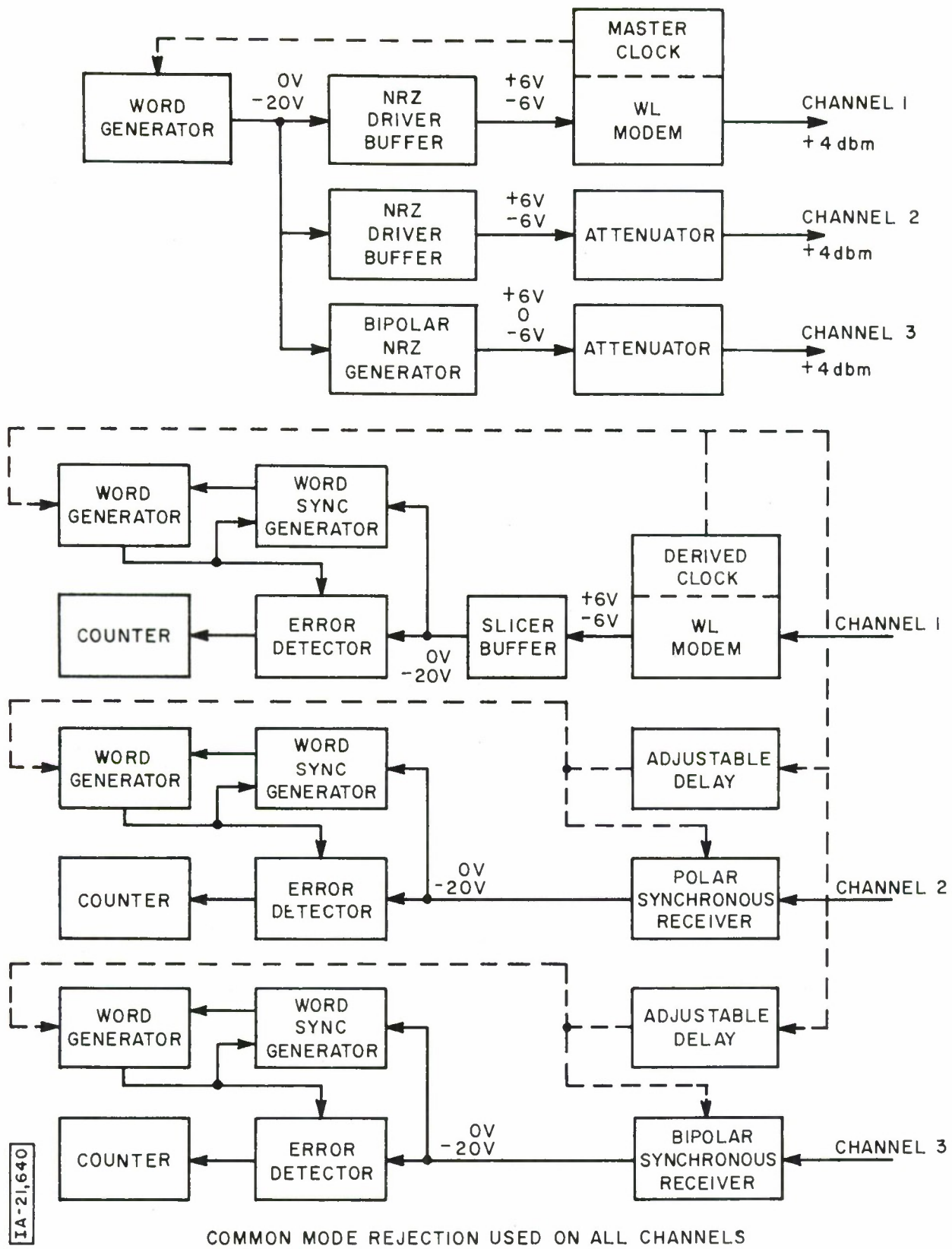

Figure 5. MEASUREMENTS PROGRAM TEST CONSOLE

- 3) A thirty-six consecutive mark test word was used to measure pulse sag and interpolate operation at the slower data rates.
- 4) Tests were made using 16 PSVL video pairs over a total path length of 7 miles.

Based on these considerations, the tests were conducted using four distinct configurations which are described in detail below and illustrated in Figures 6 through 9.

- 1) Carrier Modulation Test Configuration (Configuration A)

The transmitter output (line side) of the AN/GSC-20 modem was connected to a multiconductor pair which was looped back and connected to the receiver input (line side) of the same modem.

- 2) Polar NRZ Test Configuration (Configuration B)

This configuration is identical to configuration A except that the modem transmitter and receiver are replaced by those used for the polar NRZ baseband transmission tests. The polar NRZ receiver uses an integrate and dump detection device (simple RC filter). The unbalanced test set transmitter (word generator) output and receiver input were made compatible with the balanced line configuration by using audio transformers. The appropriate synchronization and error correction counting equipment is also interconnected.

- 3) Bipolar NRZ Test Configuration (Configuration C)

This configuration is identical to configuration A except that the modem transmitter and receiver are replaced by those used for the bipolar NRZ baseband transmission tests. The bipolar NRZ receiver also uses an integrate and dump detection device. The original test configuration allowed these three configurations to be operated in parallel.

- 4) Modem Keying Test Configuration (Configuration D)

The polar NRZ transmitter output is connected to a multiconductor pair which was looped back and connected to the modulator input of the AN/GSC-20 modem. In addition, the modem transmitter and receiver are connected back to back or through a short length ($\frac{1}{2}$ mile) or multi-conductor cable. The unbalanced to balanced and balanced to unbalanced conversions are made with audio transformers.

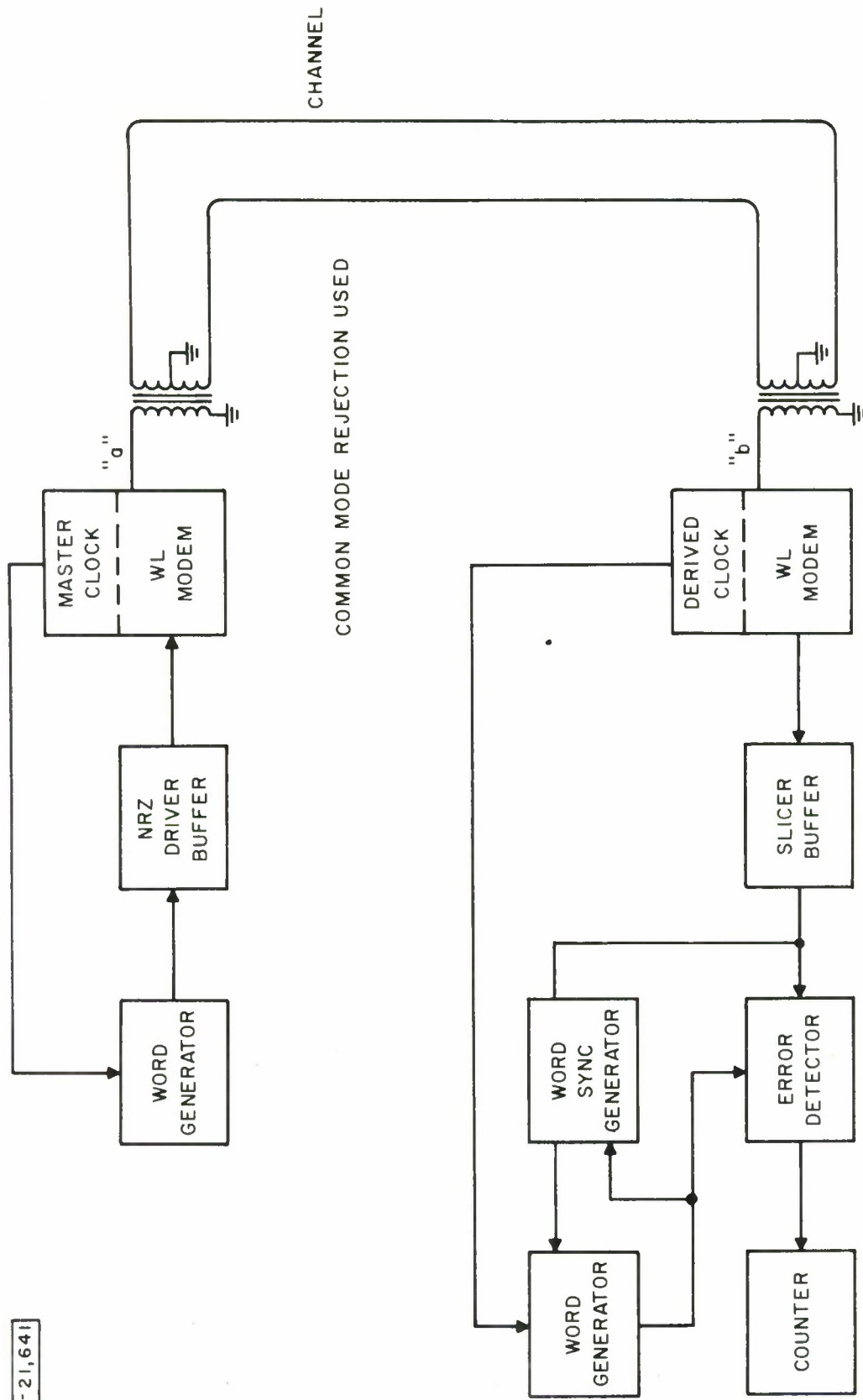

Figure 6. CARRIER MODULATION TEST CONFIGURATION (CONFIGURATION A)

IA-21,642

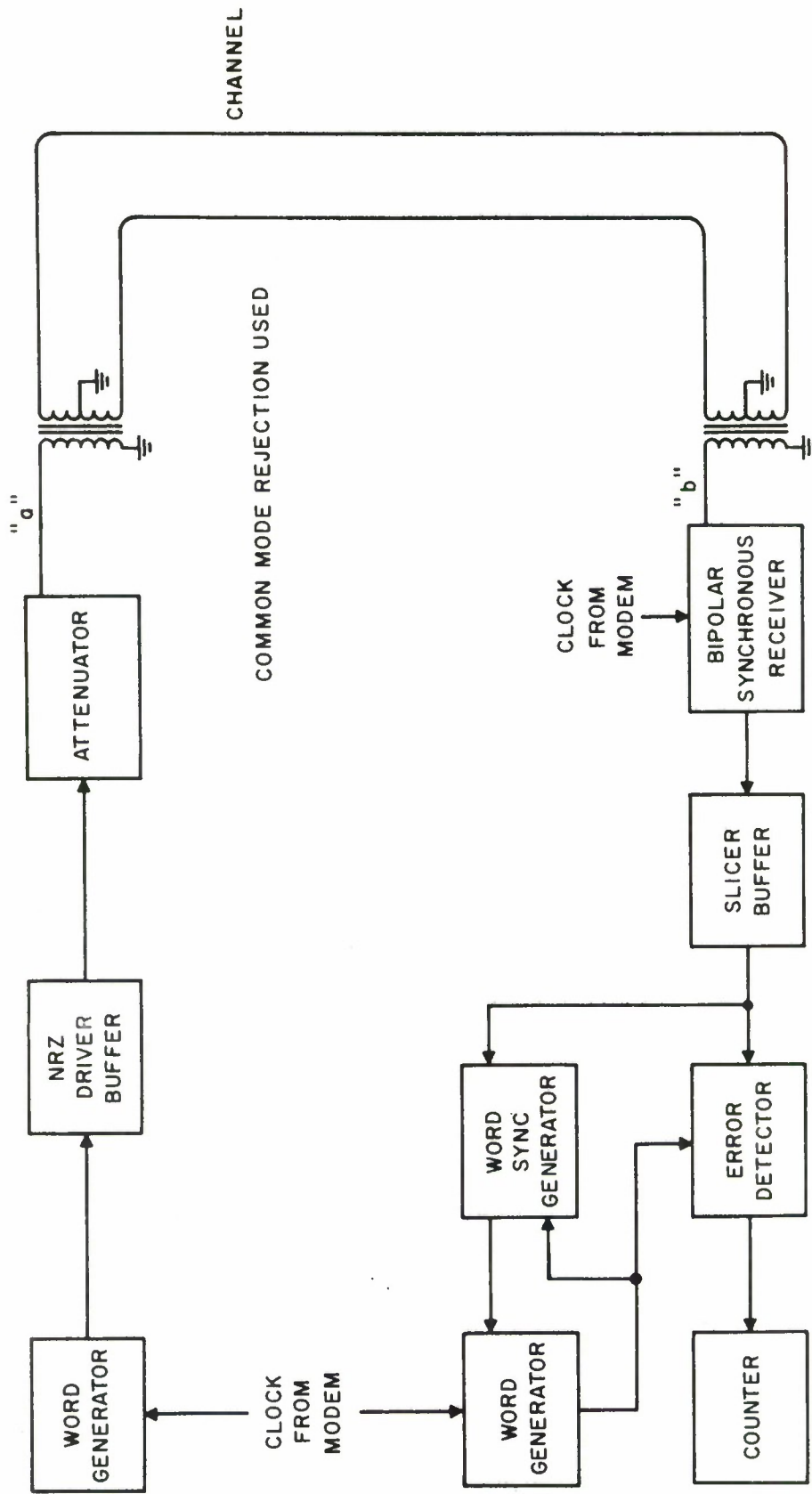

Figure 7. POLAR NRZ TEST CONFIGURATION (CONFIGURATION B)

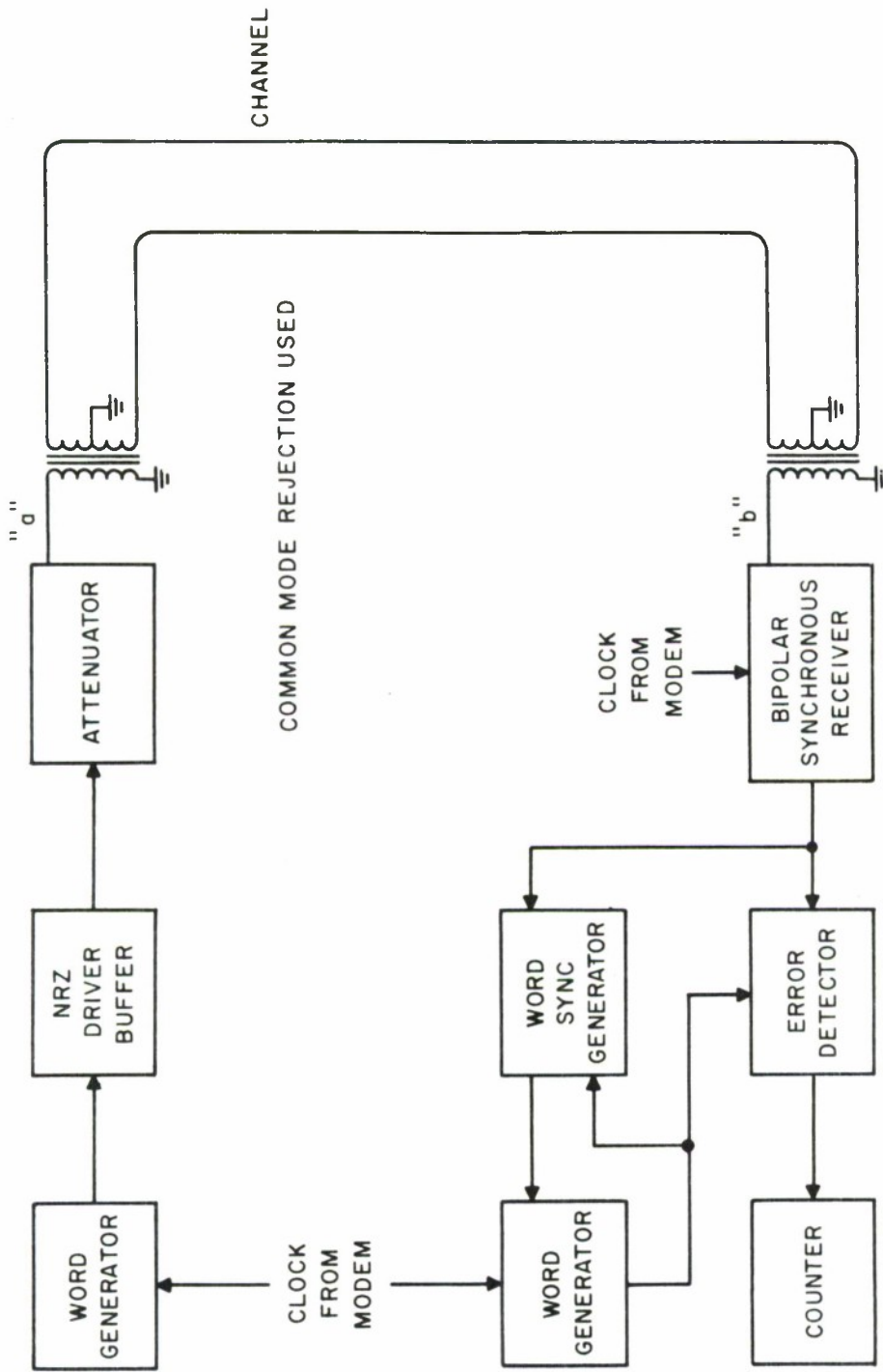

Figure 8. BIPOLAR NRZ TEST CONFIGURATION (CONFIGURATION C)

IA-21,644

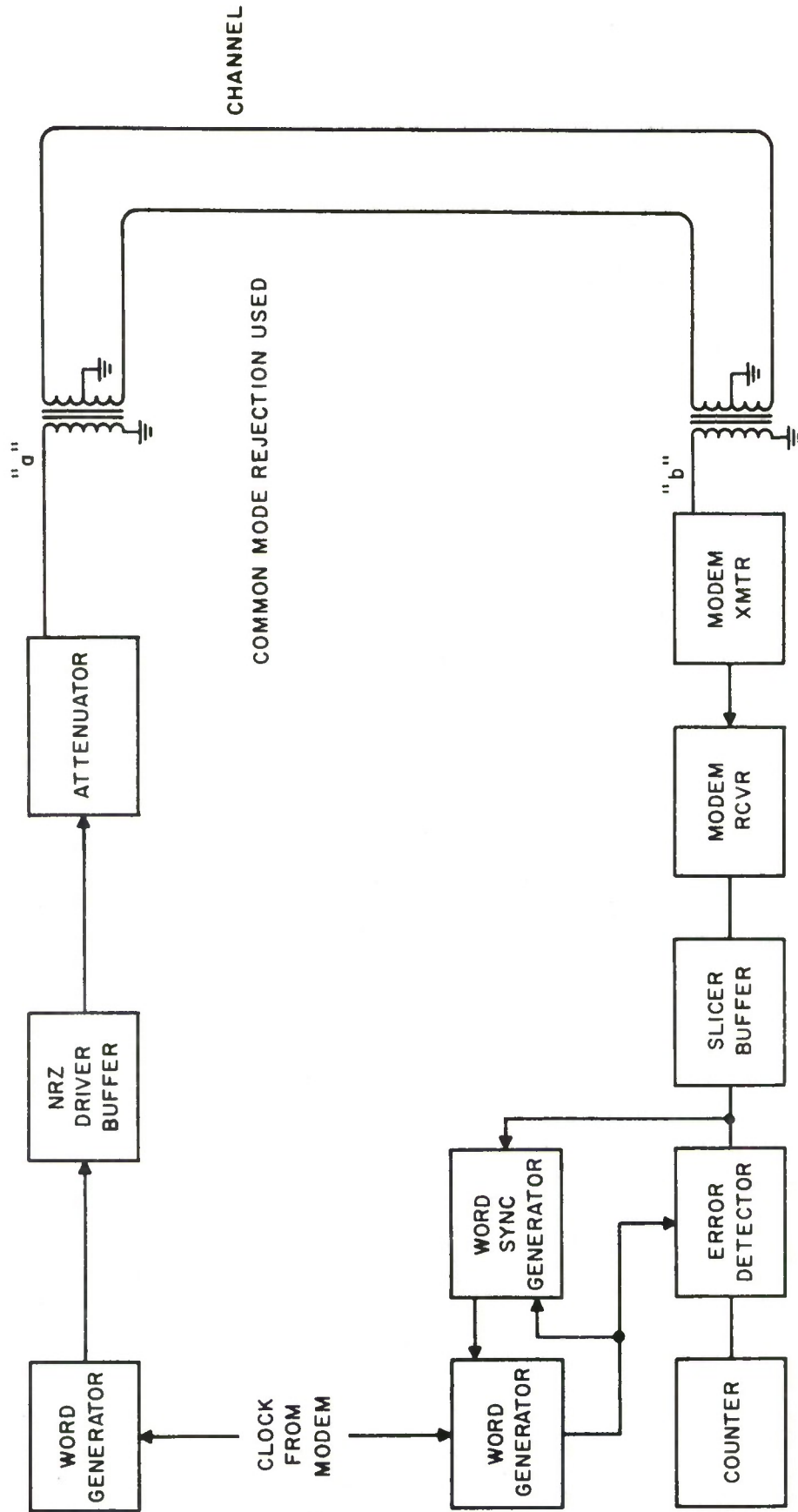

Figure 9. MODEM KEYING TEST CONFIGURATION (CONFIGURATION D)

The channels which were used in the above configurations were of 3 cable types and they are designated by the following letter code:

Type F - 22 AWG Twisted Pair

Type G - Wideband Video Pair (16 PSVL)

Type H - 19 AWG Twisted Pair

Typical parameters for these lines are given in Table II.

Two test code words were used in the tests. They were both 52 bits long including a 16 bit synchronization word. They are also designated by a letter code and their formats are diagrammed below.

Code Word X

This code word consisted of 36 pseudorandom bits and a 16 bit synchronization word. This word was used to simulate a typical message word structure. The word format was:

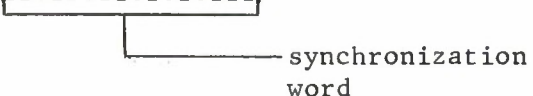
00111100001111111111111000011110000111101001101010111,

Code Word Y

This code word consisted of 36 consecutive spaces and a 16 bit synchronization word. This word was used to test the d.c. characteristics of the wire line channels under test. The word format was:

0001101001101010111,

Description of Test Results

Both oscilloscope photographs and sketches were taken to illustrate the signal transmission characteristics of the various wire line pairs under test. In addition, bit error rate measurements were also taken for the various configurations, lines, and word formats explained above. The detailed results were as follows:

TABLE II

Typical Parameters of 22 AWG, 19 AWG Non-Loaded, and 16 PSVL Cables

Type of Cable	R (ohms/mile)	G (mho/mile)	L (h/mile)	C (μ f/mile)	characteristic impedance (ohms)	attenuation (db/mile)
22 AWG	166	2.1	0.001	0.083	416-j 399	1.80
19 AWG	84	1	0.001	0.06	345-j 319	1.06
16 PSVL	44	8.3	0.0012	0.52	282-j 236	0.675

Values for $f = 1$ KHz

Signal Transmission Characteristics

The group of oscilloscope photographs and sketches (Figures 3.6 - 3.16) illustrate the signal transmission characteristics of typical CKAFS lines. The upper trace shows the input signal to the primary of the input transformer (point "a" in Figures 6 through 9) and the bottom trace show the output signal from the secondary of the output transformer (point "b" in Figures 6 through 9).

In all cases, the signal level to the primary of the transformer was +4 dbm and the data rate was 2400 bits/second.* The attenuation on the 22 AWG lines was about 1 db/mile up to 3 miles in length and the rise time of the received pulse varied from about 25% for a $\frac{1}{2}$ mile line to about 200% of the signaling interval for a 3 mile line. The rise time of the received pulse was greater than 200% over the 19 AWG line but the test word is very distinguishable.** The attenuation and rise time of the received pulse over the 7 miles of PSVL video pair was 1.5 db and 125% of signaling interval respectively.

Measurements of pulse sag were performed using a 1 mile 22 AWG line and a test word with 36 consecutive spaces followed by a 16 bit synchronization word. Over the 1 mile line, 10% sag was experienced in the 36 consecutive spaces. This corresponds to 15 milliseconds which is equivalent to

36 bits @ 2400 b/s

18 bits @ 1200 b/s

9 bits @ 600 b/s

4.5 bits @ 300 b/s

The significant pulse sag visible in the following oscilloscope photographs (Figures 10 - 20) and sketches was mostly caused by a pulse amplifier with a poor DC response used in the test configuration.

* Some voltage unbalance existed on the polar and bipolar signals. However, the effects of this unbalance (if significant at all) would make the results slightly pessimistic.

** The 52 bit sequence can be visually recognized in the oscillograms

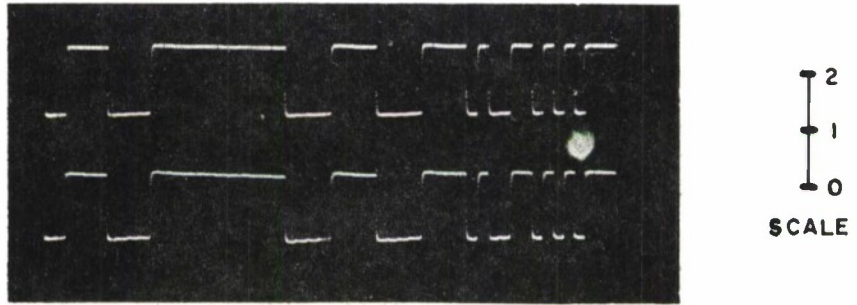

FIGURE 10. - POLAR NRZ SIGNAL TRANSMITTED AT 2400 BITS/SECOND OVER A 1/2 MILE 22AWG NON-LOADED LINE (VERTICAL SCALE - 2 VOLTS/DIVISION, HORIZONTAL SCALE - 2 MILLISECONDS/DIVISION)

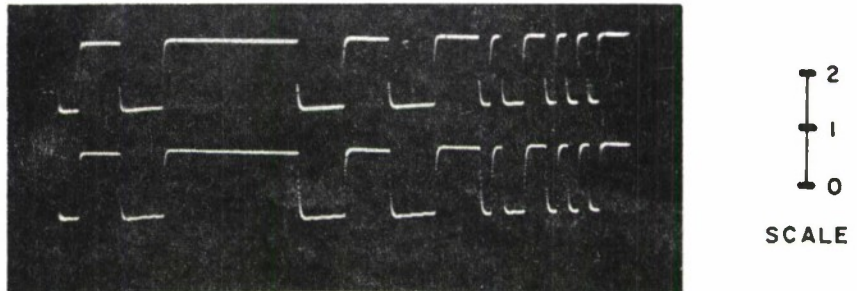

FIGURE 11. - POLAR NRZ SIGNAL TRANSMITTED AT 2400 BITS/SECOND OVER A 1 MILE 22AWG NON-LOADED LINE (VERTICAL SCALE - 2 VOLTS/DIVISION, HORIZONTAL SCALE - 2 MILLISECONDS/DIVISION)

IA-21,649

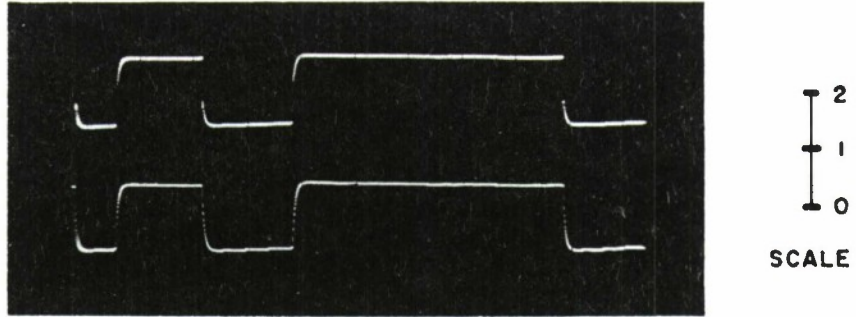

FIGURE 12. - POLAR NRZ SIGNAL TRANSMITTED AT 2400 BITS/SECOND OVER A 1 MILE 22AWG NON-LOADED LINE-EXPANDED TIME SCALE
(VERTICAL SCALE - 2 VOLTS/DIVISION, HORIZONTAL SCALE - 1 MILLISECOND/DIVISION)

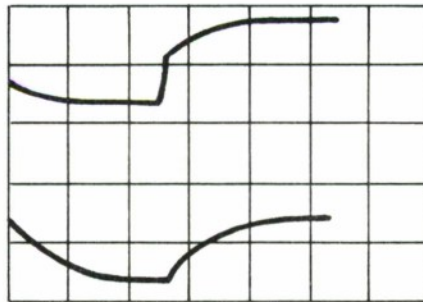

FIGURE 13. - POLAR NRZ SIGNAL TRANSMITTED AT 2400 BITS/SECOND OVER A 2 MILE 22AWG NON-LOADED LINE
(VERTICAL SCALE - 2 VOLTS/DIVISION, HORIZONTAL SCALE - 200 MICROSECONDS/DIVISION)

1A-21,651

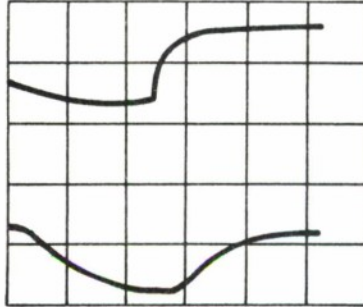

FIGURE 14. - POLAR NRZ SIGNAL TRANSMITTED AT 2400 BITS/SECOND OVER A 3 MILE 22AWG NON-LOADED LINE
(VERTICAL SCALE - 2 VOLTS/DIVISION, HORIZONTAL SCALE - 200 MICROSECONDS/DIVISION)

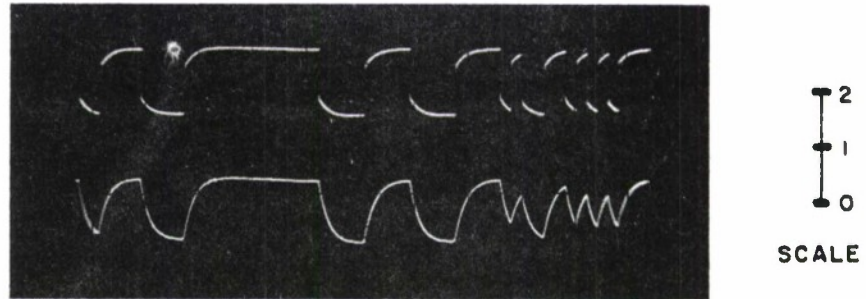

FIGURE 15. - POLAR NRZ SIGNAL TRANSMITTED AT 2400 BITS/SECOND OVER A 5 MILE 19AWG NON-LOADED LINE
(VERTICAL SCALE - 2 VOLTS/DIVISION, HORIZONTAL SCALE - 2 MILLISECONDS/DIVISION)

1A-21,652

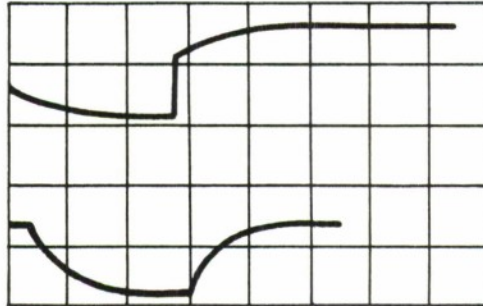

FIGURE 16. - POLAR NRZ SIGNAL TRANSMITTED AT 2400 BITS/SECOND OVER A 7 MILE 16 PSVL WIDEBAND VIDEO LINE (VERTICAL SCALE - 2 VOLTS/DIVISION, HORIZONTAL SCALE - 200 MICROSECONDS/DIVISION)

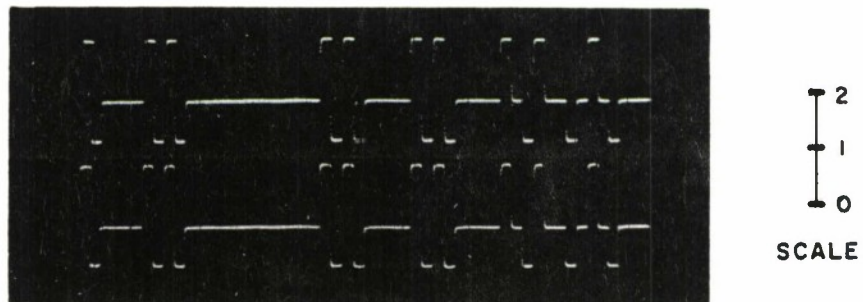

FIGURE 17. - BIPOLAR NRZ SIGNAL TRANSMITTED AT 2400 BITS/SECOND OVER A 1/2 MILE 22AWG NON-LOADED LINE (VERTICAL SCALE - 2 VOLTS/DIVISION, HORIZONTAL SCALE - 2 MILLISECONDS/DIVISION)

IA-21, 654

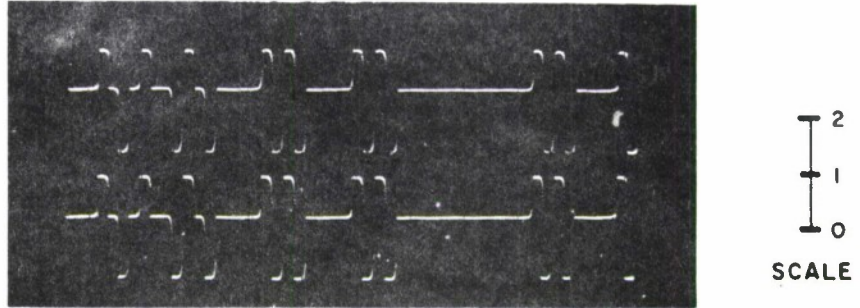

FIGURE 18. - BIPOLAR NRZ SIGNAL TRANSMITTED AT 2400 BITS/SECOND OVER A 1 MILE 22AWG NON-LOADED LINE (VERTICAL SCALE - 2 VOLTS/DIVISION, HORIZONTAL SCALE - 2 MILLISECONDS/DIVISION)

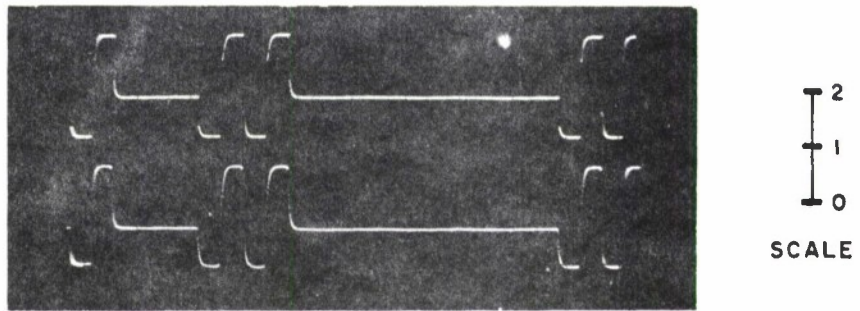

FIGURE 19. - BIPOLAR NRZ SIGNAL TRANSMITTED AT 2400 BITS/SECOND OVER A 1 MILE 22AWG NON-LOADED LINE - EXPANDED TIME SCALE (VERTICAL SCALE - 2 VOLTS/DIVISION, HORIZONTAL SCALE - 1 MILLISECOND/DIVISION)

IA-21,650

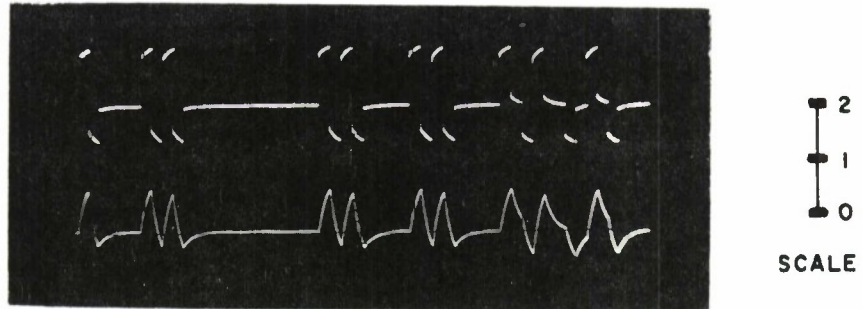

FIGURE 20. - BIPOLAR NRZ SIGNAL TRANSMITTED AT 2400 BITS/SECOND OVER A 5 MILE 19AWG NON-LOADED LINE (VERTICAL SCALE - 2 VOLTS/DIVISION, HORIZONTAL SCALE - 2 MILLISECONDS/DIVISION)

IA-21,653

Error Rate Performance

The results of the intra-site baseband data transmission error rate tests are summarized briefly in Table III. A detailed description of the test results is given below. Each test in Table III is identified by a three letter code entered in the column labeled "Mode". The first letter designates the test configuration, the second designates the type of transmission line used as the channel, and the last indicates the test word format.

In all tests, the crosstalk levels measured with a balanced instrument were less than -85 dbm. In addition, the transmitted polar and bipolar signal levels were +4 dbm except where indicated while the transmit modem signal level was always +3.5 dbm. All tests were conducted at 2400 bits/second. Errors were introduced before and after each test to confirm the correct operation of the error counting subsystem.

a) Test 1 through 3

Tests 1 through 3 were conducted simultaneously over ≈ 1 mile (5300 feet) 22 AWG lines for eight hours ($\approx 10^8$ bits). The original test console which combined configurations A, B, and C was used. Neither the polar, bipolar, nor modem systems made any errors using the pseudo random 52 bit word.

b) Tests 4 through 6

Test 4 through 6 were also conducted simultaneously over $\approx \frac{1}{2}$ mile (2900 feet) 22 AWG lines for eight hours. Again the original test console was used. Neither the polar, bipolar, or modem systems made any errors using the 52 bit pseudo random.

c) Test 7

In test 7, the polar NRZ technique was operated over a ≈ 3 mile (17,400 feet) line for 5 hours ($\approx 5 \times 10^7$ bits). Only configuration B of the test console was connected for this test. The system made no errors using the 52 bit pseudo random test word. This same test was also attempted over a 5 mile 19 AWG line but the system would not synchronize.

d) Tests 8 and 9

Test 8 and 9 were conducted sequentially for 15 minutes each ($\approx 2.5 \times 10^6$ bits) by connecting the test console as configuration D and using the 52 bit pseudo-random test word. In test 8, the polar signal was transmitted to the modem modulator through a ≈ 3 mile (17,400 feet) 22 AWG line. The modem itself was operated back to back through a $\approx \frac{1}{2}$ mile (2900 feet) 22 AWG line.

TABLE III

SUMMARY OF ERROR RATE PERFORMANCE TEST RESULTS

<u>TEST</u>	<u>MODE</u>	<u>TRANSMITTED POWER</u>	<u>PATH LENGTHS</u>	<u>TOTAL BITS</u>	<u>TOTAL BIT ERRORS</u>
1	AFX	+3.5 dbm	1 mile	10^8	0
2	BFX	+4 dbm	1 mile	10^8	0
3	CFX	+4 dbm	1 mile	10^8	0
4	AFX	+3.5 dbm	$\frac{1}{2}$ mile	10^8	0
5	BFX	+4 dbm	$\frac{1}{2}$ mile	10^8	0
6	CFX	+4 dbm	$\frac{1}{2}$ mile	10^8	0
7	BFX	+4 dbm	3 miles	5×10^7	0
8	DFX	+4 dbm	3 miles	2.5×10^7	22
9	DFX	+4 dbm	1 mile	2.5×10^7	0
10	DGX	+4 dbm	7 miles	2×10^7	0
11	DFX	+4 dbm	2 miles	2×10^7	0
12	DFX	+4 dbm	3 miles	2.5×10^7	7
13	DFX	+6 dbm	3 miles	5×10^6	0
14	AFY	+4 dbm	1 mile	10^7	0
15	BFY	+4 dbm	1 mile	10^7	0
16	CFY	+4 dbm	1 mile	10^7	0
17	BGX	+4 dbm	7 miles	10^7	0
18	CGX	+4 dbm	7 miles	2.5×10^6	0

Test Configurations:

- A Modem Transmitter-Channel-Modem Receiver
- B Polar NRZ Transmitter-Channel-Polar NRZ Receiver
- C Bipolar NRZ Transmitter-Channel-Bipolar NRZ Receiver
- D Polar NRZ Transmitter-Channel-Modem Modulator

Channel Designations:

- F 22 AWG Twisted Pair
- G Wideband Video Pair (16 AWG PSVL)
- H 19 AWG Twisted Pair

Test Word Formats:

- X 52 Bit Sequence
(36 Pseudorandom Bits plus 16 Bit Synchronization Word)
- Y 52 Bit Sequence
(36 Spaces plus 16 Bit Synchronization Word)

The polar system made no errors while the modem system made 22 errors. In test 9, the polar signal was transmitted to the modem modulator through a ≈ 1 mile (5800 feet) 22 AWG line while the modem again was operated back to back through a $\approx \frac{1}{2}$ mile (2900 feet) 22 AWG line. Neither system made any errors during this test.

e) Test 10

This test was also performed by connecting the test console as configuration D and using the 52 bit pseudo random test word. The polar signal was transmitted to the modem modulator through a 7 mile (16 PSVL) video pair. The modem was operated back to back through a $\approx \frac{1}{2}$ mile (2900 feet) 22 AWG line as previously. Neither system made any errors in 2 hours ($\approx 2 \times 10^7$ bits).

f) Test 11

This test was identical to test 10 except that the polar signal was transmitted to the modem modulator through a ≈ 2 mile (11,600 feet) 22 AWG line. Neither system made any errors in the 2 hours.

g) Tests 12 and 13

These tests were performed within the test console operated in configuration D for 15 minutes ($\approx 2.5 \times 10^6$ bits) with the 52 bit pseudo-random test word. In both, the polar signal was transmitted to the modem modulator through a ≈ 3 mile (17,400 feet) 22 AWG line. The modem was operated the same as in the other tests using configuration D. In test 12, the polar signal level was +4 dbm. The polar system made no errors and the modem system made 7 errors. In test 13, the polar signal level was increased to +6 dbm. This time neither system made any errors.

h) Tests 14, 15, and 16

These tests were performed simultaneously over ≈ 1 mile (5800 feet) 22 AWG lines for 1 hour ($\approx 1 \times 10^7$ bits). The test console was operated as configuration A, B, and C in parallel. The 52 bit test word consisted of 36 consecutive spaces followed by the synchronization word. Neither system made any errors.

i) Tests 17 and 18

These tests were performed sequentially over 7 mile (16 PSVL) lines using the 52 bit pseudo random test word. Test 17 was performed using configuration B. No errors were recorded during the 1 hour test. Test 18 was performed using the configuration C. Again no errors were recorded during the 1 hour test.

SECTION IV

ANALYSIS AND INTERPRETATION OF RESULTS

Present NRD Multi-pair Circuits

From the test results presented in Section III, the use of baseband signaling techniques for intra-station data transmission appears feasible. The crosstalk levels experienced on balanced NRD multipair cables during normal and heavy traffic conditions were insignificant (≈ -87 dbm). The peak attenuation on the 2400 bits/second polar signal was about 1 db/mile on the 22 AWG lines and slightly less for the 19 AWG lines. The attenuation experienced by the 2400 b/s polar signal on the 16 PSVL video line was about 0.2 db/mile.

The pulse rise time and decay time on the 22 AWG lines varied from about 25% of the pulse interval at 2400 b/s over $\frac{1}{2}$ mile lines to about 100% of the pulse interval over 3 mile lines. A 5 mile 19 AWG line exhibited rise and decay time considerably longer than one bit interval at 2400 bit/sec but the test word was still distinguishable. The rise and decay times of 19 AWG lines are somewhat shorter than the identical lengths of 22 AWG. The video lines as expected exhibited good rise time characteristics. The rise time of 100% of the signaling interval was experienced over 7 mile video lines.

Tests revealed that the d.c. sag caused by the lines was negligible at the data rates being considered (300, 600, 1200, 2400 bits/second). As mentioned previously, the d.c. sag noticeable in the figures was caused by a poor performance pulse amplifier in the test console.

Expected Performance

Based on the error rate performance tests, the following performance can be expected in the present NRD multipair environment.

- 1) Subscribers up to at least 3 miles away can reliably key the AN/GSC-20 (or AN/USC-12) modem directly through present #19 and #22 AWG pairs with a +4 dbm (+2.5 volts) polar NRZ signal.

- 2) Subscribers up to at least 7 miles away can reliably key the AN/GSC-20 (or AN/USC-12) modem directly through present video 16 PSVL pairs with a 4 dbm (± 2.5 volts) polar NRZ signal.

Simulation Tests for Multi-pair Circuits

Although the direct keying performance obtained on the NRD multi-pair circuits was encouraging, it was far short of theoretical expectations. The probable reason for this is the current NRD practice of splicing stubs into existing circuits. These stubs can produce loading conditions which can increase the attenuation and/or decrease bandwidths of the multi-pair circuits. To determine the performance which could be expected on clean intra-site lines, simulated 22 AWG lines were used with the test console in the laboratory under the same conditions used for the field tests.

The parameters of the simulated lines were measured and were found to check closely with tabulated parameters for 22 AWG lines. The laboratory tests with these simulated lines were performed with configuration D. The following group of oscilloscope photographs (Figures 21 through 34) illustrate the signal transmission characteristics of these artificial lines. The upper trace shows the input signal to the primary of the input transformer (point "a" in Figure 9) and the bottom trace shows the output signal from the secondary of the output transformer (point "b" in Figure 9).

The considerable attenuation evident in these oscilloscope photographs was due primarily to transformer loading. The attenuation was slightly less than that observed for the same length circuits.

The bandwidths of the simulated line was somewhat better than those observed at CKAFS. The simulated 26,500 foot, 22 AWG line passed the 2400 bit/second polar signal with a 100% rise and decay time. A 4800 bit/second polar signal suffered some attenuation due to insufficient bandwidths, but the test word was distinguishable.

A bit error performance test was performed over the simulated 26,500 foot 22 AWG line using configuration D of the test console. The polar system and the modem made no errors in a 2 hour period ($\approx 2 \times 10^7$ bits).

The test results for simulated multi-pair circuits indicate that with clean lines, the following can be achieved with 22 AWG and 19 AWG circuits.

- 1) Subscribers up to 5 miles away can reliably key (error free) the AN/GSC-20 modem directly through clean unmatched 22 AWG (or 19 AWG) lines using a 2400 bits/second polar NRZ signal, at +4 dbm signal transmit level.
- 2) A polar NRZ signal can be recovered reliably (error free) after being transmitted over a 5 mile 22 AWG (or 19 AWG) clean unmatched cable.

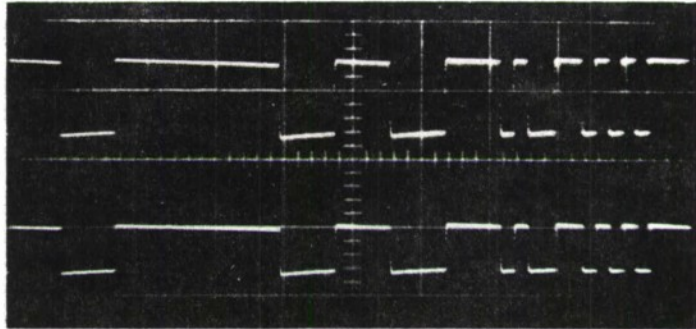

FIGURE 21. - POLAR NRZ SIGNAL TRANSMITTED AT 2400 BITS/SECOND OVER A SIMULATED 2500 FOOT 22AWG NON-LOADED LINE
(VERTICAL SCALE - 2 VOLTS/DIVISION, HORIZONTAL SCALE - 2 MILLISECONDS/DIVISION)

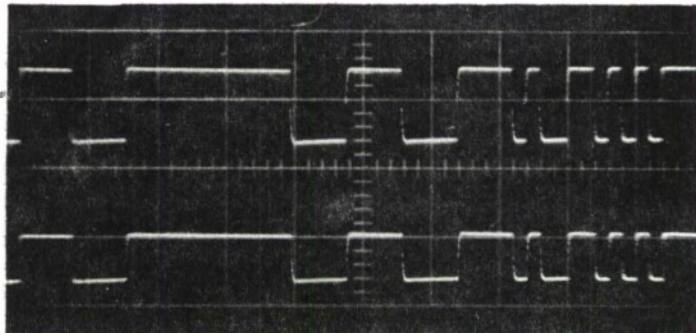

FIGURE 22. - POLAR NRZ SIGNAL TRANSMITTED AT 4800 BITS/SECOND OVER A SIMULATED 2500 FOOT 22AWG NON-LOADED LINE
(VERTICAL SCALE - 2 VOLTS/DIVISION, HORIZONTAL SCALE - 1 MILLISECOND/DIVISION)

IA-21,661

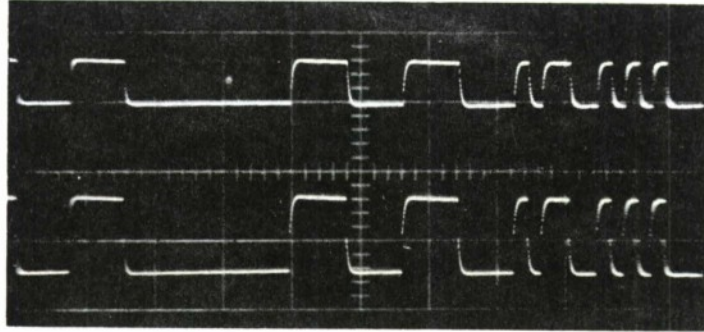

FIGURE 23. - POLAR NRZ SIGNAL TRANSMITTED AT 2400 BITS/SECOND OVER A SIMULATED 5250 FOOT 22AWG NON-LOADED LINE
(VERTICAL SCALE - 2 VOLTS/DIVISION, HORIZONTAL SCALE - 2 MILLISECONDS/DIVISION)

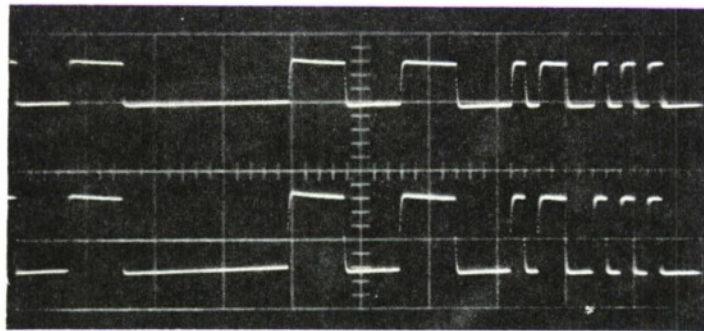

FIGURE 24. - POLAR NRZ SIGNAL TRANSMITTED AT 4800 BITS/SECOND OVER A SIMULATED 5250 FOOT 22AWG NON-LOADED LINE
(VERTICAL SCALE - 2 VOLTS/DIVISION, HORIZONTAL SCALE - 1 MILLISECOND/DIVISION)

1A-21,656

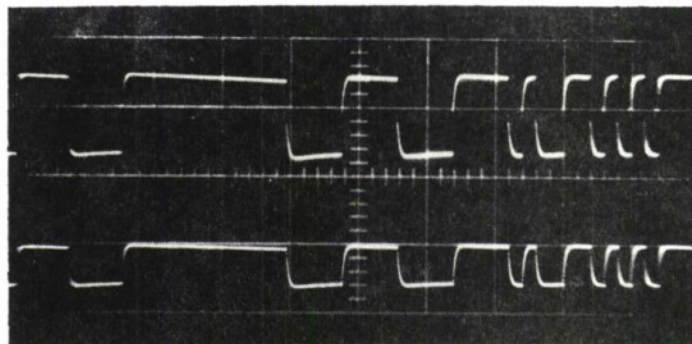

FIGURE 25. - POLAR NRZ SIGNAL TRANSMITTED AT 2400 BITS/SECOND OVER A SIMULATED 10,500 FOOT 22AWG NON-LOADED LINE
(VERTICAL SCALE - 2 VOLTS/DIVISION, HORIZONTAL SCALE - 2 MILLISECONDS/SECOND)

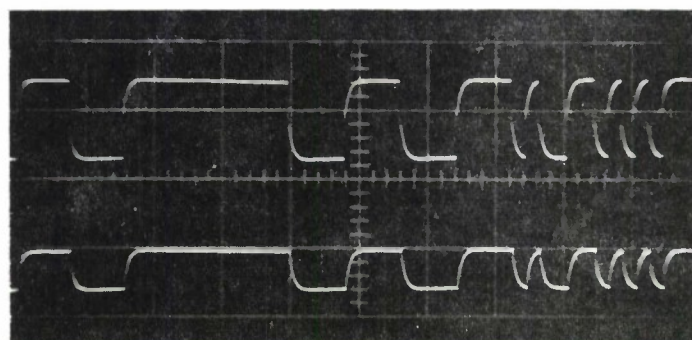

FIGURE 26. - POLAR NRZ SIGNAL TRANSMITTED AT 4800 BITS/SECOND OVER A SIMULATED 10,500 FOOT 22AWG NON-LOADED LINE
(VERTICAL SCALE - 2 VOLTS/DIVISION, HORIZONTAL SCALE - 1 MILLISECOND/SECOND)

IA-21,658

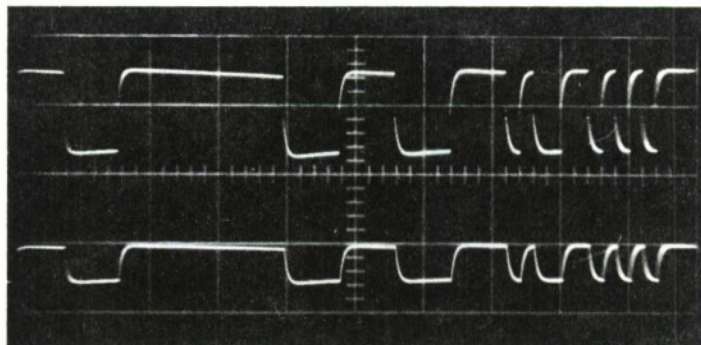

FIGURE 27. - POLAR NRZ SIGNAL TRANSMITTED AT 2400 BITS/SECOND OVER A SIMULATED 15,750 FOOT 22AWG NON-LOADED LINE
(VERTICAL SCALE - 2 VOLTS/DIVISION, HORIZONTAL SCALE - 2 MILLISECONDS/DIVISION)

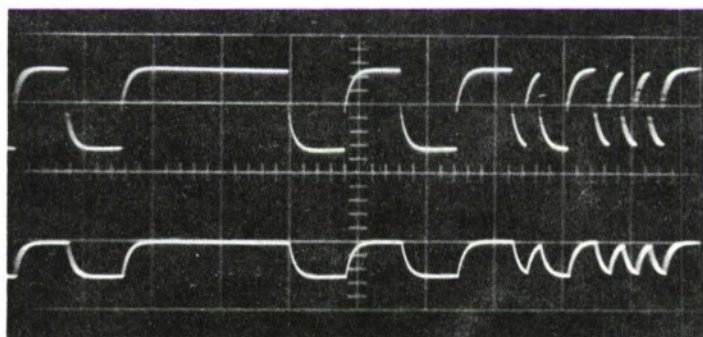

FIGURE 28. - POLAR NRZ SIGNAL TRANSMITTED AT 4800 BITS/SECOND OVER A SIMULATED 15,750 FOOT 22AWG NON-LOADED LINE
(VERTICAL SCALE - 2 VOLTS/DIVISION, HORIZONTAL SCALE - 1 MILLISECOND/DIVISION)

IA-21,655

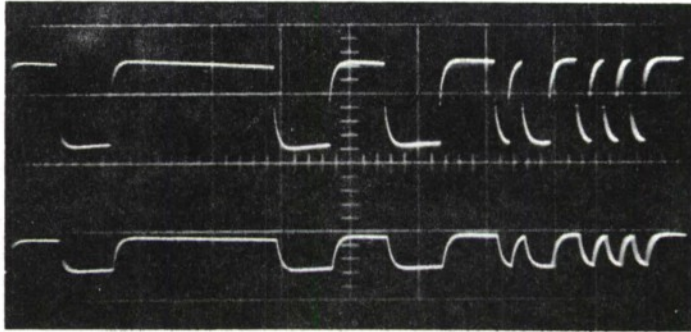

FIGURE 29. - POLAR NRZ SIGNAL TRANSMITTED AT 2400 BITS/
SECOND OVER A SIMULATED 21,000 FOOT 22AWG NON-LOADED
LINE
(VERTICAL SCALE - 2 VOLTS/DIVISION, HORIZONTAL SCALE -
2 MILLISECONDS/DIVISION)

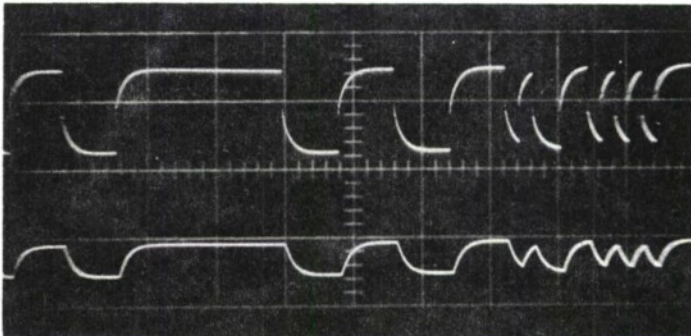

FIGURE 30. - POLAR NRZ SIGNAL TRANSMITTED AT 4800 BITS/
SECOND OVER A SIMULATED 21,000 FOOT 22AWG NON-LOADED
LINE
(VERTICAL SCALE - 2 VOLTS/DIVISION, HORIZONTAL SCALE -
1 MILLISECOND/DIVISION)

1A-21,659

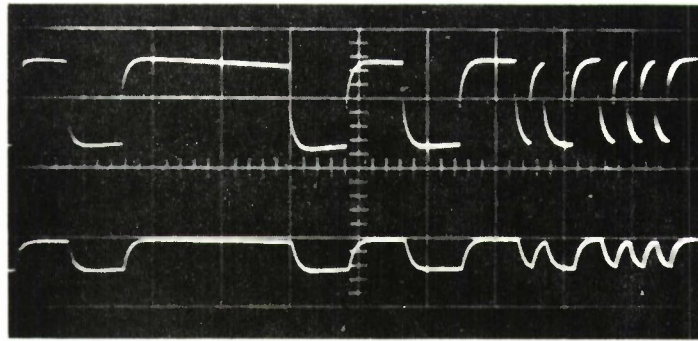

FIGURE 31. - POLAR NRZ SIGNAL TRANSMITTED AT 2400 BITS/SECOND OVER A SIMULATED 26,500 FOOT 22AWG NON-LOADED LINE
(VERTICAL SCALE - 2 VOLTS/DIVISION, HORIZONTAL SCALE - 2 MILLISECONDS/DIVISION)

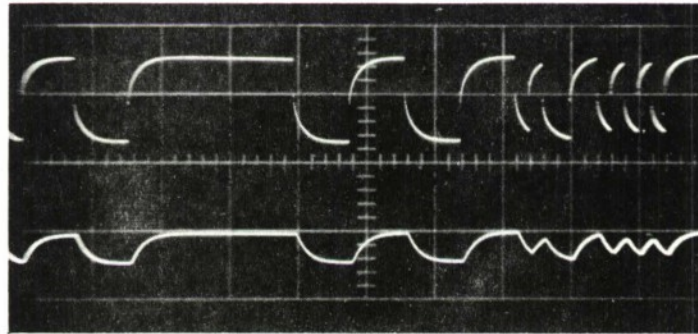

FIGURE 32. - POLAR NRZ SIGNAL TRANSMITTED AT 4800 BITS/SECOND OVER A SIMULATED 26,500 FOOT 22AWG NON-LOADED LINE
(VERTICAL SCALE - 2 VOLTS/DIVISION, HORIZONTAL SCALE - 1 MILLISECOND/DIVISION)

IA-21,660

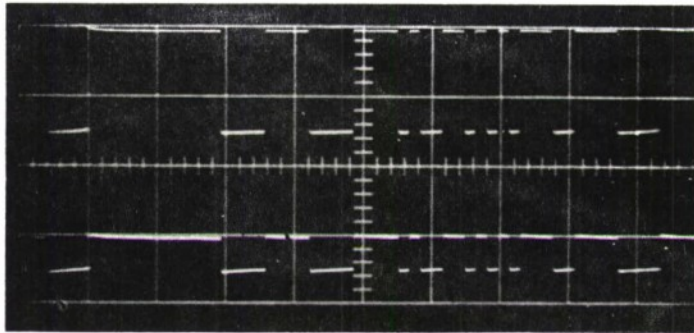

FIGURE 33. - POLAR NRZ SIGNAL TRANSMITTED AT 300 BITS/SECOND OVER A SIMULATED 26,500 FOOT 22AWG NON-LOADED LINE
(VERTICAL SCALE - 2 VOLTS/DIVISION, HORIZONTAL SCALE - 20 MILLISECONDS/DIVISION)

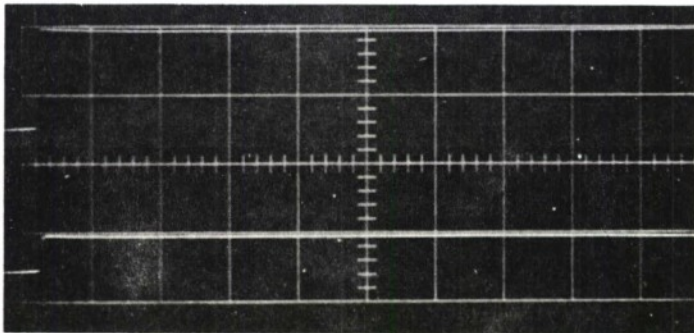

FIGURE 34. - POLAR NRZ SIGNAL TRANSMITTED AT 300 BITS/SECOND OVER A SIMULATED 26,500 FOOT 22AWG NON-LOADED LINE - 12 CONSECUTIVE MARKS
(VERTICAL SCALE - 2 VOLTS/DIVISION, HORIZONTAL SCALE - 100 MILLISECONDS/DIVISION)

1A-21,657

SECTION V

SYSTEM APPLICATIONS CONSIDERATIONS

Possible Configurations

By utilizing polar NRZ keying at baseband over NRD intra-site links, the basic communications system between two data subscribers can be envisioned in 2 configurations as shown in Figures 35 and 36. In the first configuration which is preferred, the data source transmits polar NRZ over a wire pair to the local site transmit modem modulator. The data source is timed from the modem clock which is transmitted back to the data source over another wire pair and shaped. The modem transmits the analog data over a communications medium to the receiver modem of another site. The modulated output and derived clock of the receive modem are both transmitted over separate wire pairs to the data sink where the data is regenerated to interface with sink logic.

The second or the alternate configuration differs from the first only in the fact that the data clock is located at the data source. Now it must be transmitted to the transmit modem for clocking purposes. To maximize the distance of the tail end segment direct keying the following areas should be given careful engineering considerations in the system design.

Matching

The results of present and simulated NRD link tests indicated that mismatches can substantially decrease the useful range of baseband transmission over wire pairs. For instance, substantial improvement over the existing NRD lines was obtained with an identically terminated line simulator. It is believed that with more sophisticated yet inexpensive matching networks, the transmission distance can be increased substantially over that already obtained without careful matching.

Synchronization

In both configurations envisioned for the tail segment links, the timing must also be transmitted over wire pairs. In the modem modulator and most likely in the data sink, the clock is

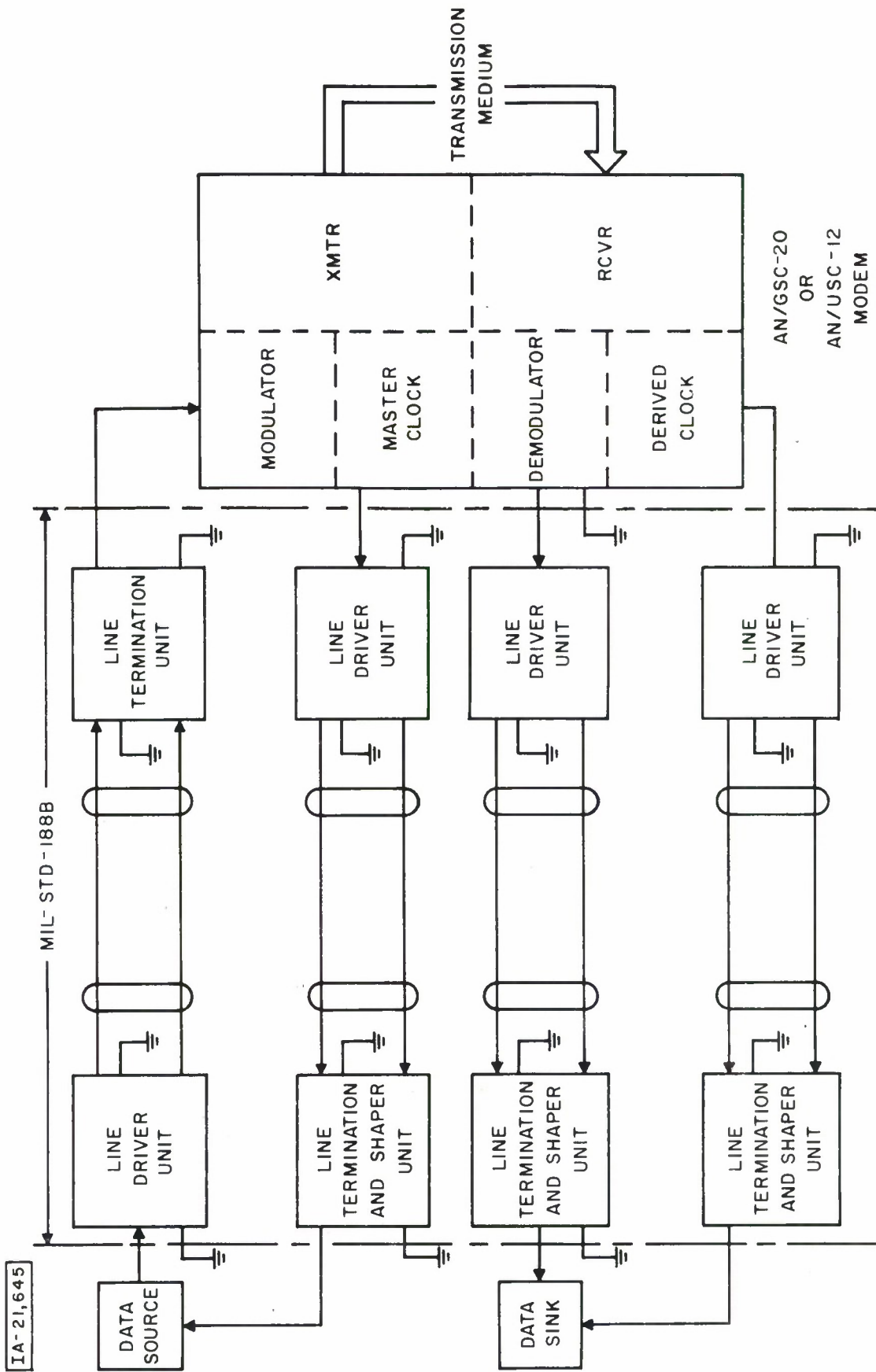

Figure 35 PREFERRED INTRA-SITE BASEBAND DATA COMMUNICATIONS SYSTEM CONFIGURATION

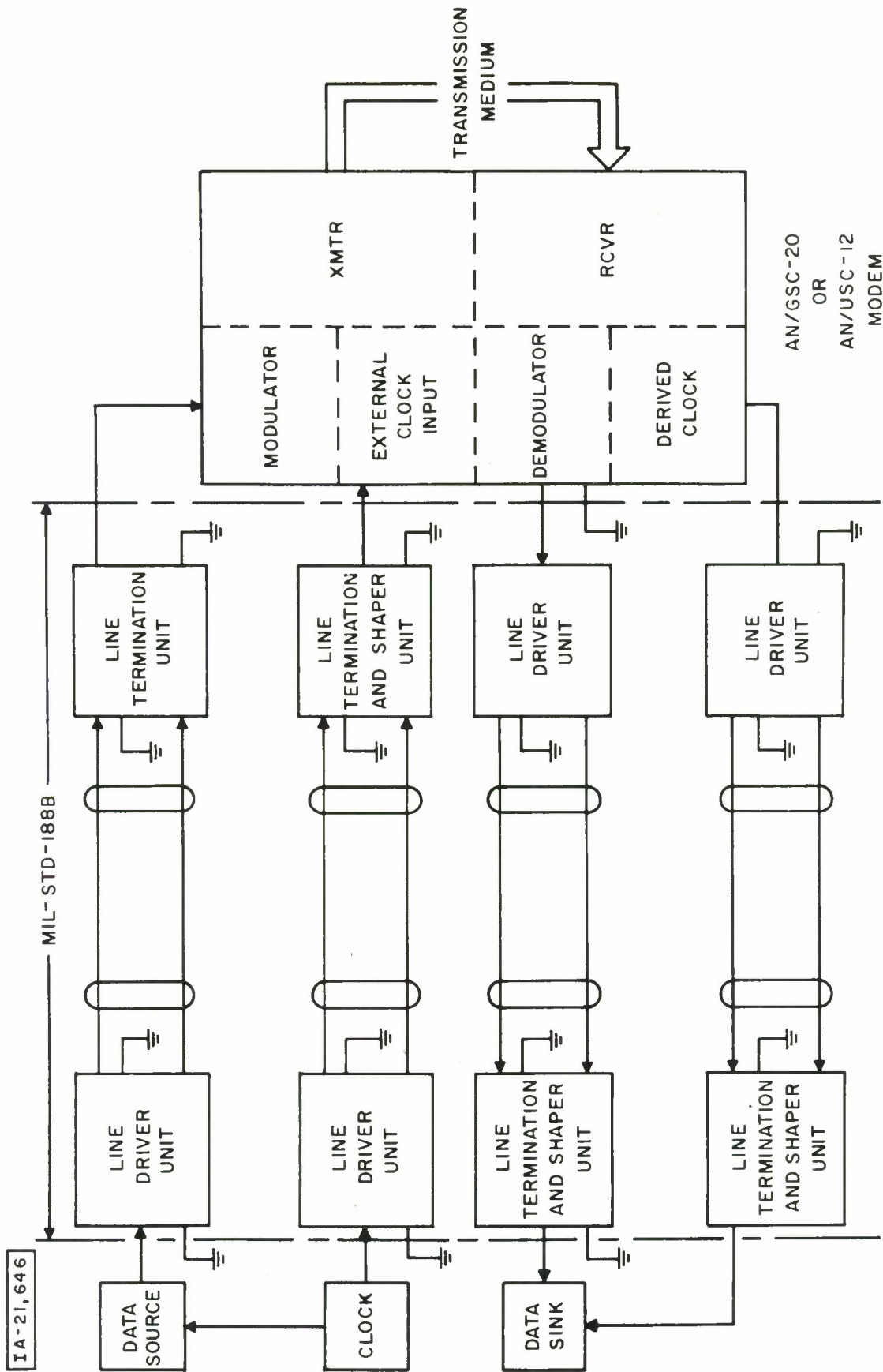

Figure 36. ALTERNATE INTRA-SITE BASEBAND DATA COMMUNICATIONS SYSTEM CONFIGURATION

used to sample the pulse centers of the data. A good clock can be obtained by transmitting a sine wave to the appropriate receiver and reshaping it.

Noise Rejection

The predominant noise present in the tail end links will be induced noise from external sources. An effective technique available to combat this type noise is the common mode rejection line configuration already described previously in Section II.

In all the tests, the unbalanced to balanced and balanced to unbalanced transformations were made with United Transformer Corp., model A-20 audio coupling transformers. The electrical balance obtained with these devices was determined by laboratory measurements using the configuration shown in Figure 5.3. The noise generator inserted between points 4 and 3 simulate induced interference and noise potential difference due to unequal ground potentials between the different cable plant terminations at a site.

The following interference signals were injected into the test configuration:

- a) 1 kHz sine wave
- b) Thermal noise with 20 kHz bandwidth*
- c) Thermal noise with 500 kHz bandwidth*

and the following rejection measurements were obtained:

- a) Rejection of 66 db against 1 kHz sine wave
- b) Rejection of 44 db against thermal noise (20 kHz)
- c) Rejection of 25 db against thermal noise (500 kHz)

This common mode rejection performance should be adequate for most tail segment applications. In an extremely noisy environment, more protection than supplied by common mode rejection can be obtained by using individually shielded wire pairs in addition

* General Radio Model 1390A noise generator was used.

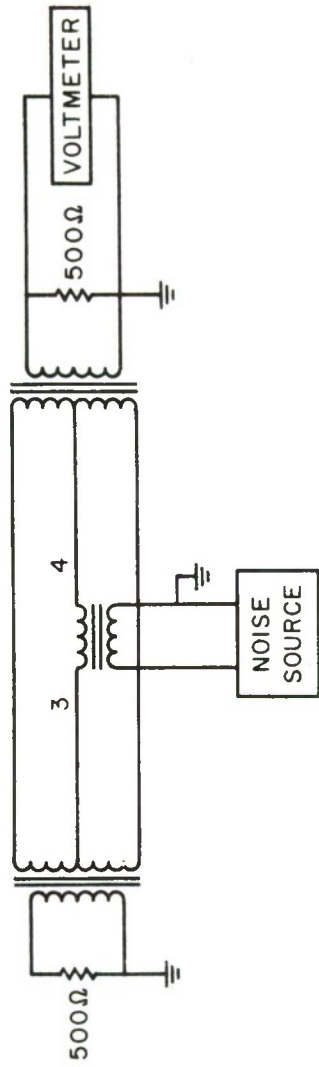

Figure 37. COMMON MODE REJECTION TEST CONFIGURATION

to common mode rejection. When the interfering signal is an RF carrier with modulation rates within the desired signal bandwidth, additional filtering using low pass/high rejection type line filters may be required.

Cost Effectiveness Considerations

Given the following methods of implementing tail segment data transmission links, let us now examine the rationale to be used in selecting a particular implementation. First, it is assumed that a given performance level is defined in terms of the maximum permissible bit error rate, and corresponding data transmission rate. The distance in cable length between the end terminals is then specified, in terms of the size and type cable available for the link. In addition, specific factors influencing performance such as induced levels of noise which are in excess of nominal values associated with these links must be identified.

The problem now is select that implementation which satisfies the performance requirements for the given link which will result in the least net total cost. The net total cost is emphasized, because this includes such factors as equipment support costs as well as initial procurement costs involved. Support costs include installation, spares maintenance, personnel support required for the equipment and other such costs in the same class.

The following implementations are considered here for comparison and cost analysis:*

- 1) Existing cable plant w/o regenerative repeaters.
- 2) Existing cable plant with regenerative repeaters.
- 3) New cable plant using Resistive Termination.
- 4) New cable plant using Matched Network Termination.
- 5) New cable plant using Matched Network Terminations and Regenerative Repeaters.

* Cost figures are given in Section I of this report.

The existing cable plant without repeaters involves no cost. With the existing cable plant plus repeaters, approximately \$250 per repeater, plus an initial cost of \$800 for the terminal power equipment needed to power the repeaters, is given.* The application of matched termination to existing links is generally not applicable unless it can be ascertained that the existing cable plant is uniform (i.e. is composed of the same type cable pair throughout the link) without spurs or other mismatching practices. When new cable plant is to be installed, there are two basic alternatives; resistive termination or matched network termination. For resistive termination, the approximation is made that the characteristic impedance of the cable is resistive over the whole frequency range of interest. In the case of matched termination, an approximation is made to match the actual characteristic impedance of the cable pair over the frequency range of interest.

The last configuration consists of the combination of matched terminations and regenerative repeaters. This implementation will permit baseband data transmission over considerably longer distances than the other implementations mentioned above. In fact distances of more than 40 miles may be achieved with #19 AWG and one repeater. The criteria for spacing the regenerative repeaters has been selected as that point in the transmission line where the signal level has been reduced to $\frac{1}{2}$ volt peak. (The line input voltage level cannot exceed 6 volts peak.)

A graphic comparison of relative costs for different tail segment data transmission links is shown in Figure 38. It is assumed that existing cable plant is obtained at no cost since it is already installed. Tests indicate that a distance of up to 3 miles for 2400 bps polar data transmission using #22 AWG cable pairs and approximately 5 miles for 2400 bps NRZ data transmission, using #19 AWG cable pairs can be obtained with existing installed cable facilities. If extension of the range of transmission over existing cable pairs is required then regenerative repeaters can be installed along the transmission path with the costs as indicated by the steps in Figure 38.

The question arises as to when new cable plant is recommended. The answer to this question is quite simple: use new cable only when the existing cable plant (installed) is not available. There is an initial installation cost for new cable which is not reflected in the curves given in Figure 38. The reason for this is simply that the costs of this will 'wash out' regardless of the implementation used, since it is the differential costs that are

* See page 53.

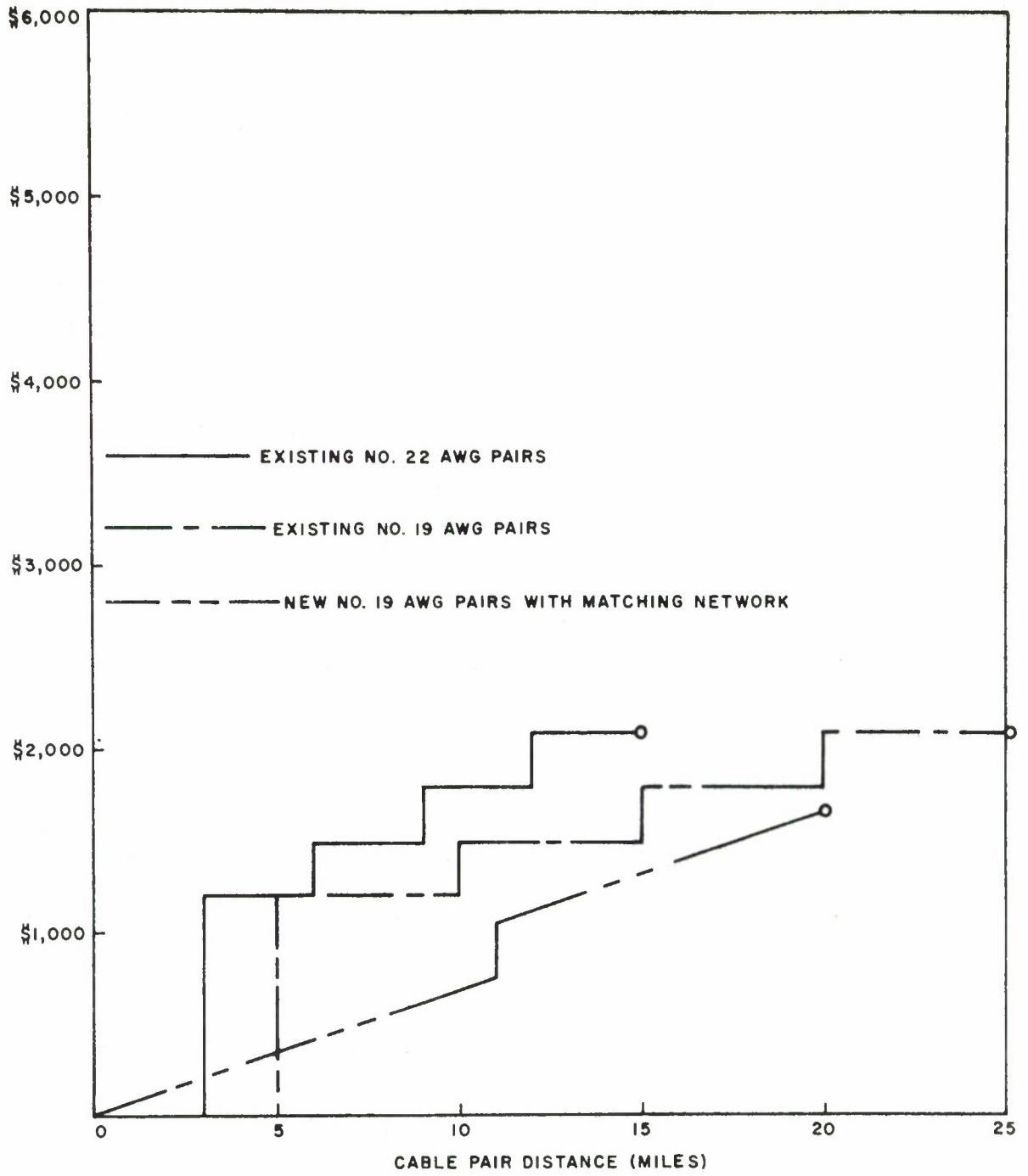

IA-21,648

Figure 38. INTRA - SITE DATA TRANSMISSION COST ANALYSIS

of concern here between the various tail segment implementations. In other words, if new cable is required, it will be needed regardless of whether modems or baseband regeneration, or matching networks are used.

What remains then are the following implementations to be compared:

- 1) Comparison of existing cable plant with regenerative repeaters vs. the use of modems with existing cable plant.
- 2) Comparison of new cable plant installed with matching networks (and repeater where required) vs. the use of modems with this new cable plant.

When the use of the modem implementation is examined, it becomes quite apparent that for distances less than 25 miles (in terms of cable length) the costs are significantly higher than that of the regenerative repeater or matching network implementations. Where the distance for tail segment transmission is greater than approximately 25 miles, the modem may be required because signal to noise effects and timing jitter with cascaded regenerative repeaters may become significant. Wherever possible, the existing #19 AWG cable pairs with regenerative repeaters installed, should be used instead of the existing #22 AWG cable pairs with repeaters. Where existing #16 PSVL cable is already installed and available, it should be used for cable distances up to approximately 20 miles (without regenerative repeaters), however, where such cable is not readily available the initial costs of purchasing and installing this type cable are such that it is not cost effective unless advantage is taken of the wide transmission bandwidth of the cable. This would be done by using multiple link data transmission in a frequency multiplex configuration. Now the cost per 2400 bps data link will be significantly reduced. (This cable has an effective bandwidth of over 2.5 Megahertz.)

The results may be summarized in the following tabulation, relating implementation method, distance and transmission medium.

<u>Existing Cable Plant</u>	<u>Maximum Distance w/o Repeaters</u>	<u>Maximum Distance with Repeaters (4 Repeaters)*</u>
#22 AWG	3 Miles	15 Miles
#19 AWG	5 Miles	25 Miles
#16 PSVL	20 Miles	- - - - -
<u>New Cable Plant</u>		
#22 AWG	5 Miles Resistive Term)	25 Miles
#19 AWG	11 Miles (Resistive Term)	55 Miles
#19 AWG	18 Miles (Matched Term)	- - - - -

* Repeater Costs per unit = \$250 plus common (power supply cost = \$800 based on industry estimates for standard commercial practice type components. (Power supply drives up to 4 repeaters.)

SECTION VI

SUMMARY

The NRD has established an operational range policy whereby all modems for intra-range and inter-range data transmission shall be located at the Range stations' Range Communications Control Center. The purpose of this policy is to assure more efficient utilization of transmission facilities on a common user basis rather than on a dedicated circuit basis. In order to implement this policy it is necessary to develop some method of transferring data between the subscriber terminals and the Range Communications Control Center. There are two general methods available to do this, namely baseband data transmission or carrier data transmission. In this report, the baseband data transmission techniques are considered in detail, since carrier techniques are inherently more complex and costly to implement, and baseband data transmission appears to be quite feasible for considerable distances.

The analysis begins with a review of transmission theory over wireline facilities, which indicates that baseband polar data transmission over distances of 11, 18, and 25 miles are achievable for #22 AWG, #19 AWG and #16 PSVL wire pairs respectively. These distances are based on the following constraints:

- 1) An input signal level of 6 volts peak (In accordance with MIL-STD-188B).
- 2) An acceptable signal level of $\frac{1}{2}$ volt peak (In accordance with MIL-STD-188B).
- 3) Impedance matching at the cable terminations over the significant frequency range of the signal (i.e. 2400 bits per second data rate).

Field tests were performed which indicated the following results for installed cable plant facilities on the Eastern Test Range.

- 1) Maximum transmission distance of 3 miles for #22 AWG.
- 2) Maximum transmission distance of 5 miles for #19 AWG.
- 3) Maximum transmission distance of ≈ 7 miles for #16 PSVL.

SECTION VII

CONCLUSIONS

With the present NRD intra-site multi-conductor pairs, the tail segment links as envisioned in Figure 5.1 and 5.2 will operate reliably with a +4 dbm polar NRZ signal transmitted over types of lines of the following lengths

22AWG	≤ 3 miles
19AWG	≤ 5 miles
16PSVL	at least 7 miles

without the use of repeaters or elaborate matching networks. All that is required is 2 inexpensive digital recovery circuits at the data sink which may be part of the data buffer capable of converting $\pm \frac{1}{2}$ volts to the ± 6 volts levels of the data logic.

If longer tail segment links are desired, baseband repeaters can be used with 22 or 19 AWG gauge lines. Cost estimates from industry indicate that baseband repeater techniques will be far cheaper than modems up to at least 25 miles on these pairs.

For links which require the installation of new pairs, clean 19 AWG lines should be installed paying specific attention to the matching. With careful matching, ranges close to theoretical (18 miles for 19 AWG nonloaded pairs) should be achieved with the proposed system configurations. With carefully engineered matched lines baseband repeater techniques will be cheaper than modems up to at least 60 miles. The appropriate matching networks which would be designed for the 19 AWG pairs should be relatively inexpensive passive networks and should be investigated further.

The cost of 16 PSVL video cable is such that it is cost competitive with a modem (over cheaper cable) up to 10 miles after which it becomes more expensive. Thus the use of 16 PSVL cable for this application is only recommended when previously installed pairs are not being utilized for video applications.

The constraints on the field tests were as follows:

- 1) Line input signal levels were restricted +4 dbm (i.e. \approx 2.5 volts peak) to prevent possible crosstalk problems with other users.
- 2) These facilities contained several splices, and changes in gauge as well as spurs.
- 3) Because the actual characteristic impedance was significantly different from the nominal value, only resistive terminations were used.
- 4) The received signal was used to drive the input of a pair of modems (AN/GSC-20) in a back to back configuration for a period of eight hours with no error recorded for a continuous period of 8 hours.

Laboratory tests were performed to measure the common mode interference rejection performance of the test set used for these tests. It was found that a minimum rejection of 66 db was achieved for a 1 kHz common mode interference signal, a minimum rejection of 44 db was observed for a white noise interference of 20 kHz bandwidth, and a rejection of 25 db for a white noise interference of 500 kHz bandwidth. It was further demonstrated that differences in ground potential between end terminals of the cable transmission system will appear as common mode interference and would be rejected accordingly.

When transmission distances greater than that available with existing cable plant facilities is needed, the use of line powered regenerative repeaters is recommended over the use of carrier equipments such as modems, etc, from the point of view of economy and operational efficiency. Such devices can easily extend the range of baseband data transmission by a factor of 4 or more at a nominal cost, and with a performance level that is at least equal to that of carrier equipments. Such devices have been used in the past and are available from the industry.

REFERENCES

1. O. Cardinale, and W. J. Ciesluk, Preliminary Investigation of NRD Intra-Station Data Transmission, MITRE WP-941, Contract AF 19(628)-5165, Bedford, Mass., 13 December 1966.
2. S. Goldman, Transformation Calculus and Electrical Transients, Prentice Hall, Inc., Copyright 1949, pp 307-311.
3. International Telephone and Telegraph Corp., Reference Data for Radio Engineers, Fourth Edition, Copyright 1956, pp 816-825.
4. American Telephone and Telegraph Company, Type A2A Video Transmission System Line Facilities, Bell System Practices, Copyright 1957.

Reference 1 has not been reviewed by the Directorate of Security, Department of Defense, and is not for public release.

DOCUMENT CONTROL DATA - R & D

(Security classification of title, body of abstract and indexing annotation must be entered when the overall report is classified)

<p>1. ORIGINATING ACTIVITY (Corporate author) The MITRE Corporation Bedford, Massachusetts</p>	<p>2a. REPORT SECURITY CLASSIFICATION Unclassified</p> <p>2b. GROUP</p>
--	---

3. REPORT TITLE
NRD Intra-Station Data Transmission Engineering

4. DESCRIPTIVE NOTES (Type of report and inclusive dates)
N/A

5. AUTHOR(S) (First name, middle initial, last name)
CARDINALE, Otto
CIESLUK, Walter J., Jr.

<p>6. REPORT DATE SEPTEMBER 1967</p>	<p>7a. TOTAL NO. OF PAGES 68</p>	<p>7b. NO. OF REFS 4</p>
--	--	--------------------------------------

<p>8a. CONTRACT OR GRANT NO. AF 19(628)-5165</p> <p>b. PROJECT NO. 705B</p> <p>c.</p> <p>d.</p>	<p>9a. ORIGINATOR'S REPORT NUMBER(S) ESD-TR-67-361</p> <p>9b. OTHER REPORT NO(S) (Any other numbers that may be assigned this report) MTR-409</p>
---	---

10. DISTRIBUTION STATEMENT
This document has been approved for public release and sale; its distribution is unlimited.

<p>11. SUPPLEMENTARY NOTES</p>	<p>12. SPONSORING MILITARY ACTIVITY Deputy for Surveillance and Control Sys., Aerospace Instrumentation Program Office, Elec. Sys. Division, L. G. Hanscom Field, Bedford, Mass.</p>
--------------------------------	---

13. ABSTRACT

Methods for transferring digital data between remote subscribers and Range Communications Control Centers within NRD sites are reviewed and baseband data transmission techniques for this purpose are examined in detail. First, the factors which influence baseband data transmission in existing NRD intra-site cable pairs are discussed. Next, a test program, which was designed to measure the transmission characteristics and the error rate performance of some simple baseband data techniques over these cable pairs, is described and the results are presented, analyzed, and interpreted. Finally, the elements which require special consideration in the design of efficient, cost effective baseband systems for intra-station data transmission are stressed and some implementation suggestions are presented.

14

KEY WORDS

LINK A

LINK B

LINK C

ROLE

WT

ROLE

WT

ROLE

WT

Range Communication Control Centers
Baseband Data Transmission
Digital Data Transmission
Subscribers