

NOLTR 67-121

AD 661225

HIGH PRESSURE CHAMBER DESIGN

1 August 1967

NOV 16 1967

NOL

UNITED STATES NAVAL ORDNANCE LABORATORY, WHITE OAK, MARYLAND

NOLTR 67-121

Distribution of this document is unlimited.

Reproduced by the  
CLEARINGHOUSE  
for Federal Scientific & Technical  
Information, Springfield, Va. 22151

25

NOLTR 67-121

**HIGH PRESSURE CHAMBER DESIGN**

Prepared by:

V. C. D. Dawson and A. E. Seigel

**ABSTRACT:** The pressure containment capability of a monobloc cylindrical chamber that remains elastic is limited by the mechanical strength of the chamber material to values of about 100,000 pounds per square inch. Higher pressures can be contained by using a shrink-fit construction or autofrettage and these techniques provide approximately twice the pressure containment capability that can be obtained with the monobloc construction. This report describes and analyzes a segmented chamber that greatly extends the high pressure capability of a cylindrical chamber in the elastic range.

Published: 1 August 1967

**U. S. NAVAL ORDINANCE LABORATORY  
WHITE OAK, MARYLAND**

UNCLASSIFIED

NOLTR 67-121

1 August 1967

**HIGH PRESSURE CHAMBER DESIGN**

This report is the result of a need to provide high strength chambers for use in hypervelocity launchers. The calculations presented indicate the large advantages that can be gained by using a segmented construction for a high pressure cylindrical chamber.

**E. F. SCHREITER**  
Captain, USN  
Commander

*R. Kenneth Lobb*

**R. KENNETH LOBB**  
By direction

CONTENTS

	Page
LIST OF SYMBOLS. . . . .	iv
INTRODUCTION . . . . .	1
TECHNICAL DISCUSSION . . . . .	1
ANALYSIS OF SEGMENTED CHAMBER. . . . .	8
SUMMARY OF CALCULATIONS. . . . .	12
LIMITATIONS TO THE SEGMENTED CHAMBER DESIGN. . . . .	13
REFERENCES . . . . .	16
APPENDIX A . . . . .	A-1

ILLUSTRATIONS

Figure	Title	Page
1	p/Y <sub>0</sub> vs Wall Ratio . . . . .	5
2	Bridgman High Pressure Test Apparatus. . . . .	6
3	Poulter Design for High Pressure Chamber . . . . .	7
4	p/Y <sub>0</sub> vs Wall Ratio (Segmented Chamber Non-autofrettaged Jacket). . . . .	10
5	p/Y <sub>0</sub> vs Wall Ratio (Segmented Chamber Auto- frettaged Jacket). . . . .	10
6	Summary Plot p/Y <sub>0</sub> vs Wall Ratio. . . . .	13
7	Design of High Pressure Chamber. . . . .	15

LIST OF SYMBOLS

$p$	pressure (psi)
$p_1$	pressure applied at bore (psi)
$Y_0$	yield strength (psi)
$d_0$	outside diameter of chamber
$d_1$	bore diameter of chamber
$d_s$	outside diameter of segments
$w_0$	$d_0/d_1$
$w_s$	$d_s/d_1$
$n$	ratio of diameter to which plastic flow has progressed to bore diameter during autofrettage of a cylinder

INTRODUCTION

The pressure capability of relatively large size (one of internal diameter greater than one inch) cylindrical vessels has been limited to values of about two hundred thousand pounds per square inch. Where pressures higher than these have been obtained, either very small sized vessels were involved or the pressures were transient. Numerous investigators have conceived of chambers which were capable of containing pressures as high as 500,000 psi, but, in general, these are of elaborate design, do not lend themselves for use in large sizes, and are not adaptable to many important applications.

The purpose of this report is to describe a cylindrical segmented high pressure chamber, which appears to be practical in large size, and which theoretically appears to have pressure capabilities as high as one million psi.

TECHNICAL DISCUSSION

A cylindrical monobloc vessel is limited in its elastic pressure containment capability by two basic facts.

a. The strength of the material, from which the vessel is constructed, is limited, and

b. The cylindrical geometry is such that high nonuniform stresses of both tension (hoop or tangential stress) and compression (radial stress) are induced at the bore by internal pressurization. The combined stress condition causes yielding at the bore.

These facts are illustrated by the equation (for example, see ref. 1 or 2) that relates the yield pressure to the yield strength of the material and the wall ratio of the cylinder:

$$P_{\text{yield}} = \frac{Y_0(w-1)^2}{\sqrt{3} w^2} \quad (1)$$

where  $P_{\text{yield}}$  is the internal pressure which would just initiate yielding at the inner bore of the cylinder. Thus, a monobloc cylinder with an infinite wall ratio,  $w$ , would only have an elastic pressure capability of  $Y_0/\sqrt{3} = 0.577 Y_0$ . Since the yield strengths of high strength steels, at least in large

sections, are limited to about 200,000 psi, the maximum pressure that can be maintained without yielding is approximately 115,000 psi.

An examination of the stress distribution in a cylinder just as it reaches the yield condition indicates that even though the bore stresses are high, the stresses progressively decrease through the wall and at the outer surface reach relatively low values. Furthermore, the application of an external pressure to a cylinder will induce a negative (i.e., compressive) hoop stress at the bore. This negative hoop stress can reach quite high values for comparatively low pressures externally applied. This suggests that the chamber should be constructed of two or more concentric cylinders in which the outer cylinder (jacket) is shrunk onto the inner cylinder (liner). This is a conventional technique that is used to increase the elastic operating pressure range of a vessel. The shrink-fit generates an interference pressure between the liner and jacket which creates negative hoop stresses (compression) at the bore of the liner and positive hoop stresses (tension) at the bore of the jacket. When internal pressure is subsequently applied to the bore of the liner, it does not create a positive hoop stress until a pressure high enough to overcome the negative hoop stress of the shrink-fit construction is reached. Even though the jacket in this situation initially has a positive hoop stress, the nonuniformity of the stress caused by the internal pressure is such that, under proper design conditions, the combined stress at the bore of the jacket will remain below the yield condition.

The shrink-fit construction does have limitations. The major one is that there is a limit to the negative stress that can be induced in the bore of the liner; namely, when the stress condition at the bore of the liner reaches the yield point in compression. Thus the maximum attainable elastic pressure capability for a shrink-fit construction is twice the value given by equation (1). This maximum value can only be realized by using a large number of concentric cylinders shrunk together, or by using a smaller number of cylinders, each having a large wall ratio.

The principle of the shrink-fit is to create initially compressive hoop stresses at the bore of the cylinder. Such compressive hoop stresses can also be created by utilizing the process of "autofrettage" during chamber manufacture. In this process the cylinder is subjected to a sufficiently high value of internal pressure to cause yielding through all, or part, of the cylinder wall. After the pressure is released, there exist residual stresses in the cylinder wall. The inner bore is left

with a residual compressive hoop stress. Hence, because of this stress, the autofrettaged cylinder is, as was the case for the shrink-fit, capable of operating elastically at a higher internal pressure.

Equation (1) gives the pressure at which yielding commences in a cylinder. However, due to the nonuniformity of the stresses, pressures greater than the yield pressure are required to cause yielding to continue through the wall of the tube. In fact, there is a unique relationship (ref. 1) between the internal pressure and the diameter to which yielding has progressed.

$$p = \frac{2Y}{\sqrt{3}} \left( \frac{w^2 - n^2}{2w^2} + \ln n \right) \quad (2)$$

Yielding will have occurred throughout the wall when  $n = w$  so that

$$p_b = \frac{2Y}{\sqrt{3}} \ln w \quad (3)$$

where  $p_b$  is the pressure required to yield the cylinder through the entire wall. Equations (2) and (3) are derived on the assumption that the chamber material has a perfectly elastic-perfectly plastic stress-strain curve. Equation (3) is usually used to estimate the burst pressure of a monobloc cylinder. The actual burst pressure would be somewhat higher due to work hardening effects in actual materials.

If a monobloc cylinder is pressurized during manufacture (i.e., autofrettaged) to values greater than that given by equation (1) but no more than that given by equation (3), upon pressure release, it will be found that residual compressive stresses exist at the bore so that a situation similar to that of the shrink-fit construction occurs. Again, however, there are limitations. If the residual stresses become high enough, yielding in compression will occur at the bore. This is called reverse yielding (ref. 3). If it is desired to have an elastic pressure capability, the autofrettage pressure must be limited to values just below the pressure that will cause reverse yielding. For wall ratios less than 2.22, a cylinder can be pressurized to the value given by equation (3) without having reverse yielding occur when the pressure is released. For wall ratios greater than 2.22 the autofrettage pressure is limited to twice the value given by equation (1) if reverse yielding is to be prevented. Within these



limits then the autofrettage pressure represents the operating pressure capability of a cylinder. A summary for the situations discussed previously, of the calculated maximum internal pressures that may be used in a cylinder which is operating elastically, is given below:

Elastic Operation

Monobloc-non-autofrettaged

$$P_{\max} = \frac{Y (w^2 - 1)}{\sqrt{3} w^2} \quad (1)$$

Monobloc-autofrettaged

$$P_{\max} = \frac{2Y \ln w}{\sqrt{3}} \quad w \leq 2.22 \quad (1a)$$

$$P_{\max} = \frac{2Y (w^2 - 1)}{\sqrt{3} w^2} \quad w \geq 2.22 \quad (1b)$$

Shrink-fit

$$P_{\max} = \frac{2Y (w^2 - 1)}{\sqrt{3} w^2} \quad (3)$$

If elastic operation is not required and reverse yielding can be tolerated, then the maximum pressure capability for all wall ratios is given by equation (3). Figure 1 shows graphically the results that have been presented thus far. Here the internal pressure divided by the yield strength of the material ( $p/Y_0$ ) is plotted as a function of the wall ratio.

Much of the work in high pressure technology has been done by P. W. Bridgman (ref. 4). A schematic of his high pressure apparatus for tensile testing of materials under hydrostatic pressure up to 450,000 psi is shown in figure 2. The pressure chamber is 0.5 inch in bore diameter and of the order of 4 inches long. The exterior of the pressure vessel is given a conical shape and is surrounded by heavy supporting rings with the same angle as the cone. The cylinder is mounted, as shown, between two opposed hydraulic presses. Internal pressure is produced by

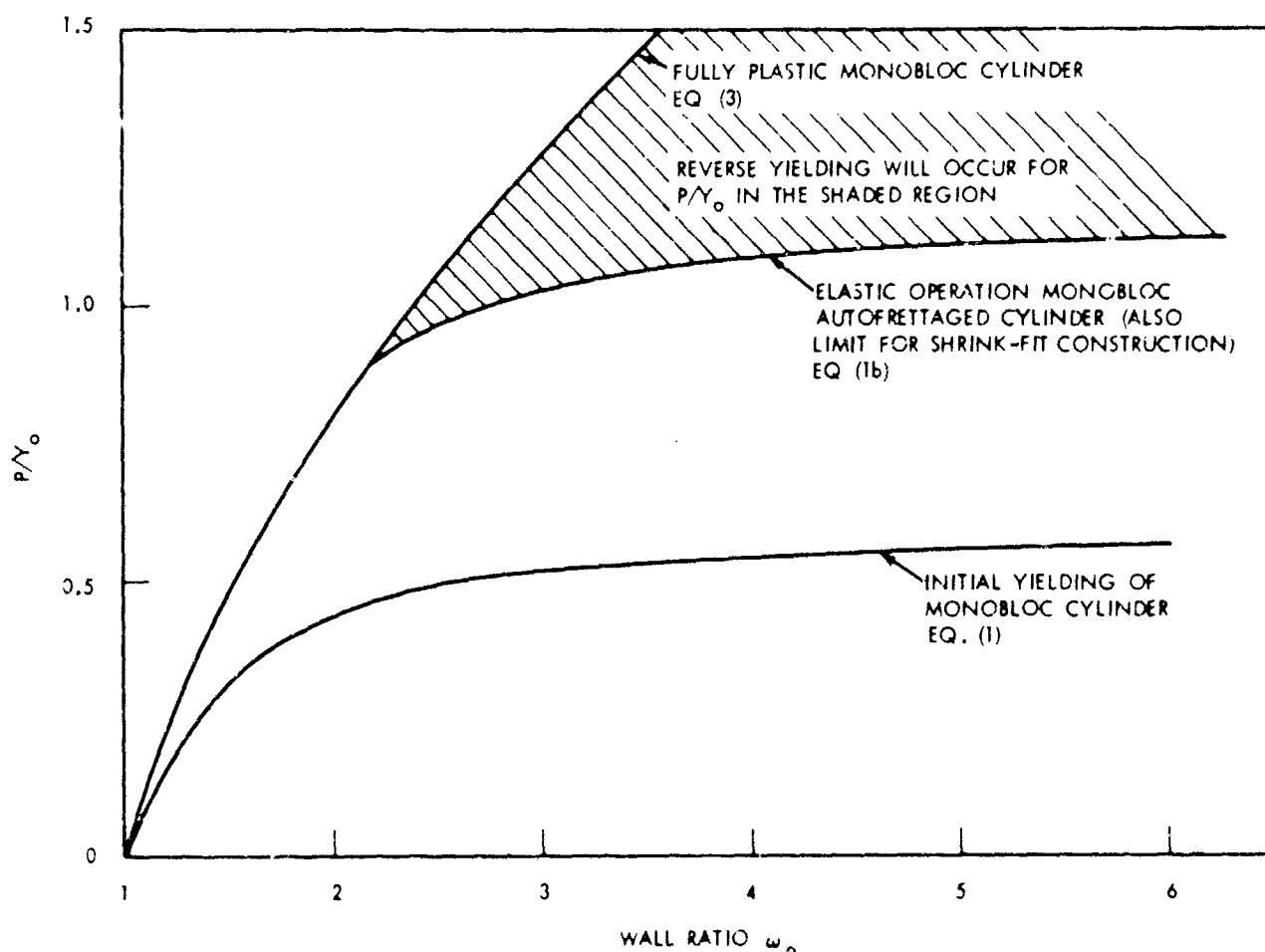

Fig. 1.  $p/Y_0$  vs Wall Ratio

the upper press, with a piston 3.5 inches in diameter which pushes a suitably packed piston of Carboloy of 0.5-inch diameter into the bore of the chamber. The lower press, with a piston 6 inches in diameter, simultaneously with the production of internal pressure, pushes the entire pressure vessel into the supporting rings, thus generating, by the action of the cone, an external pressure on the vessel which increases proportionally with the increase of internal pressure. The two presses may be coupled together so as to exert pressures automatically in the correct ratio.

Reference (5) describes various vessel designs which have been developed to increase the restricted pressure range available

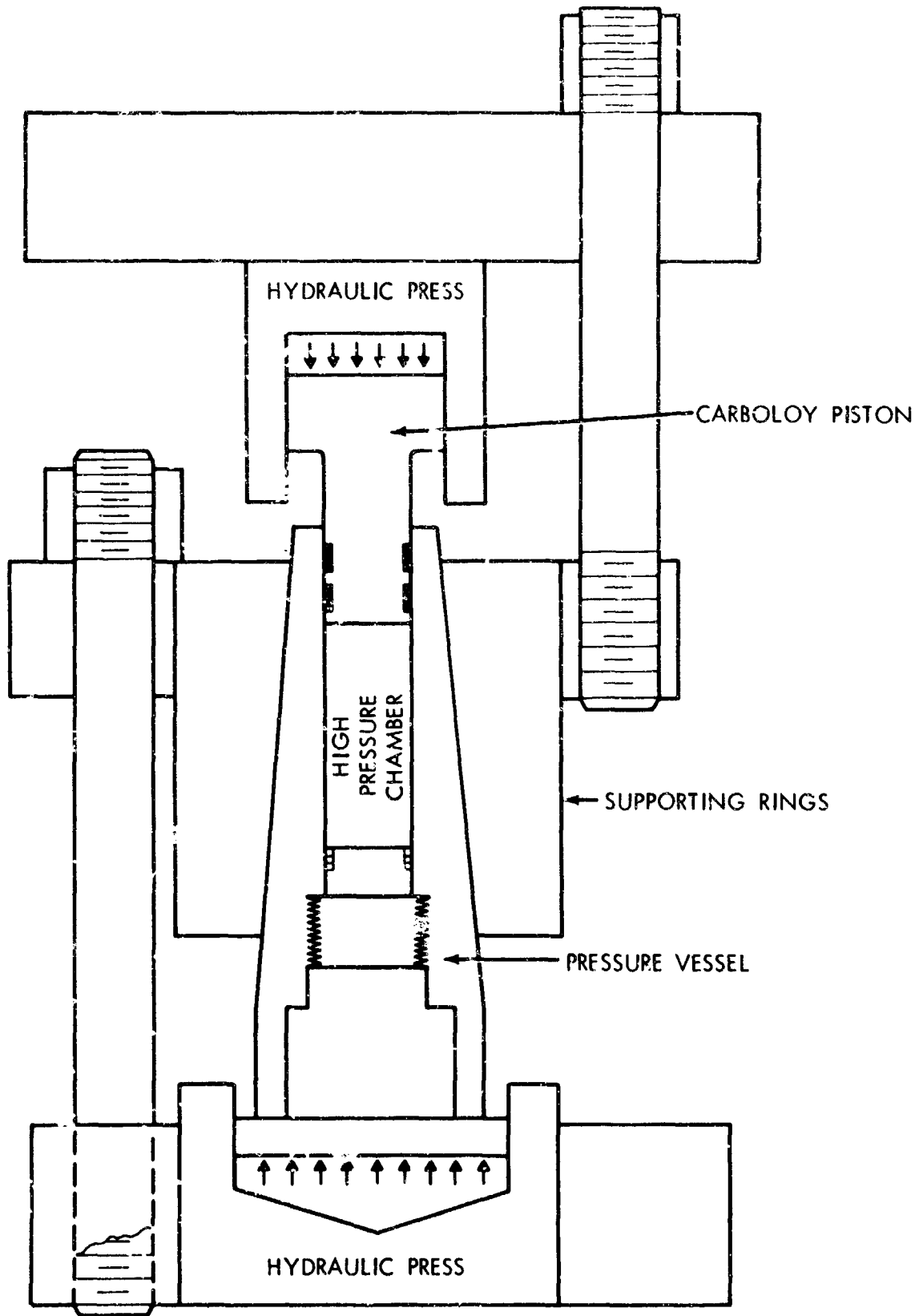

FIG. 2 BRIDGMAN HIGH PRESSURE TEST APPARATUS

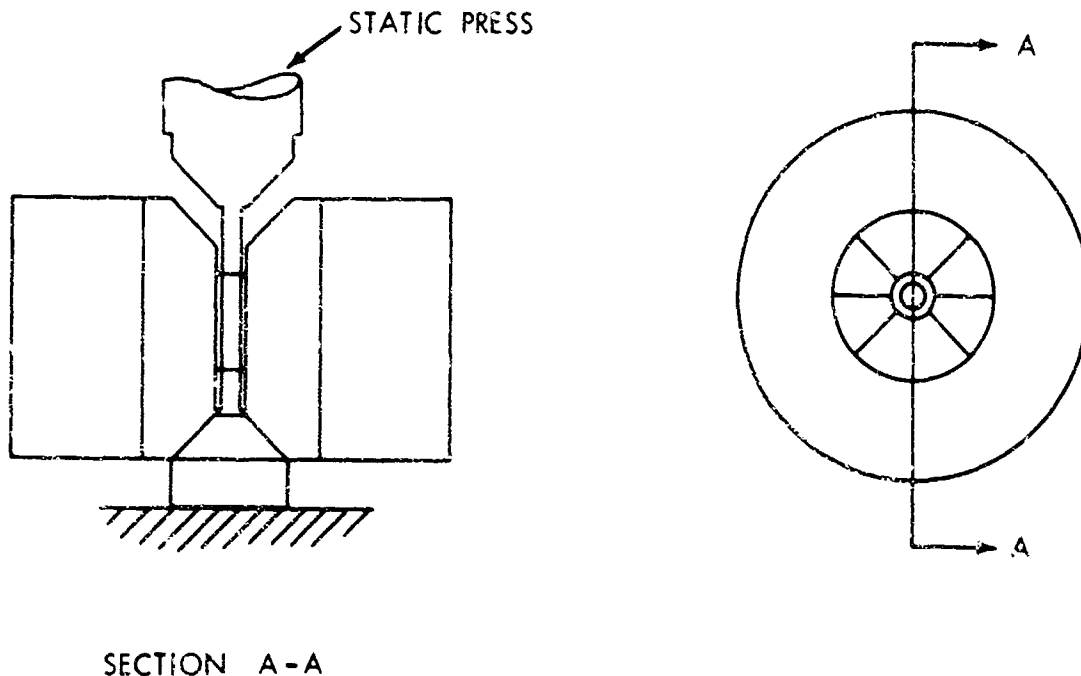
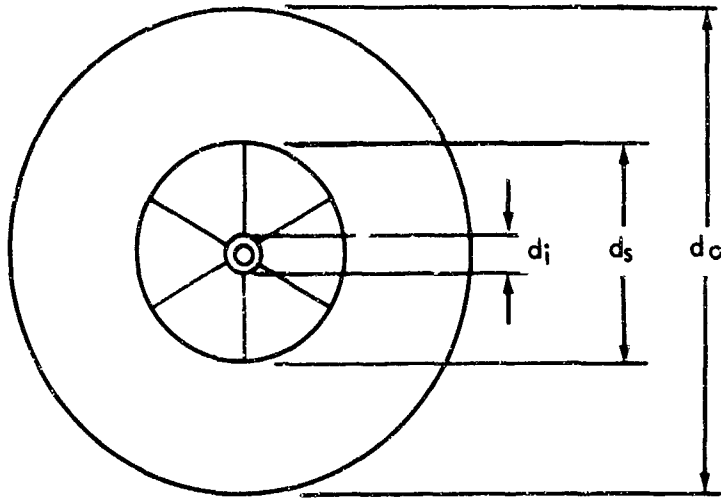

FIG. 3 POULTER DESIGN FOR HIGH PRESSURE CHAMBER

to investigators. Poulter (ref. 6) describes a chamber similar to that shown in figure 3. It consists of a thin inner elastic liner which in itself is not strong enough to carry even a small portion of the bursting forces generated by internal pressure. The bursting forces in this device are contained by a segmented ring which, in turn, is supported by an integral shell. The stresses in the outer shell are lower than they would be in an integral shell construction immediately surrounding the sealing liner. If the segmented pieces are made of a material that can withstand high compressive stress on its inner surfaces, then the chamber can handle substantially higher internal pressures than the conventional cylinder.

This report analyzes the chamber originally suggested by Poulter and indicates the optimum wall ratios for the various components. In addition, it is shown that for wall ratios  $> 3.5$  the segmented chamber with an autofrettaged outer jacket is stronger than the maximum pressure capability of a monobloc cylinder as given by equation (3).



$$\omega_s = \frac{d_s}{d_i}$$

$$\omega_o = \frac{d_o}{d_i}$$

$$\frac{d_o}{d_s} = \frac{\omega_o}{\omega_s}$$

ELASTIC INNER LINER WITH NEGLIGIBLE WALL RATIO

### ANALYSIS OF SEGMENTED CHAMBER

#### Case 1. Non-autofrettaged Jacket

When internal pressure,  $p_1$ , is applied, a pressure,  $p$ , is developed between the segments and jacket

$$p_1 d_i = p d_s$$

$$p = p_1 \frac{d_i}{d_s} = \frac{p_1}{\omega_s} \quad (4)$$

This pressure must be contained by the jacket which begins to yield when

$$p = \frac{Y [(d_o/d_s)^2 - 1]}{\sqrt{3} (d_o/d_s)^2}$$

Hence

$$p_1 = \frac{Y (\omega_o^2 - \omega_s^2) \omega_s}{\sqrt{3} \omega_o^2} \quad (5)$$

For a given value of  $w_0$  the jacket and segments should have certain dimensions to provide maximum pressure capability. These dimensions can be determined by differentiating equation (5) with respect to  $w_s$  and setting the result equal to zero.

$$\frac{dp_1}{dw_s} = \frac{Y_0}{\sqrt{3} w_0^2} [(w_0^2 - w_s^2) + (w_s - 2w_s)] = 0$$

$$w_0^2 - 3w_s^2 = 0$$

$$w_s = \frac{w_0}{\sqrt{3}} \quad (6)$$

With this value of  $w_s$  substituted into equation (5) the maximum internal pressure that can be contained by the vessel is obtained.

$$\begin{aligned} p_{1\max} &= \frac{Y_0}{\sqrt{3}} \left( \frac{w_0^2 - \frac{w_0^2}{3}}{w_0^2} \right) \frac{w_0}{\sqrt{3}} \\ &= \frac{2}{9} w_0 Y_0 \\ &= .222 w_0 Y_0 \quad (7) \end{aligned}$$

A plot of this result is shown in figure 4. Comparison with figure 1 shows the chamber is considerably stronger, in large wall ratios, than the monobloc non-autofrettaged or autofrettaged cylinder. At values of  $w_0$  less than the  $\sqrt{3}$  the use of the segmented cylinder is less strong than the monobloc construction.

#### Case 2. Autofrettaged Jacket

The preceding analysis was based upon the use of a jacket which is non-autofrettaged. Substantially higher pressure can be contained if the jacket is autofrettaged.

If the jacket wall ratio is less than 2.22 the maximum autofrettage pressure is, as given earlier,

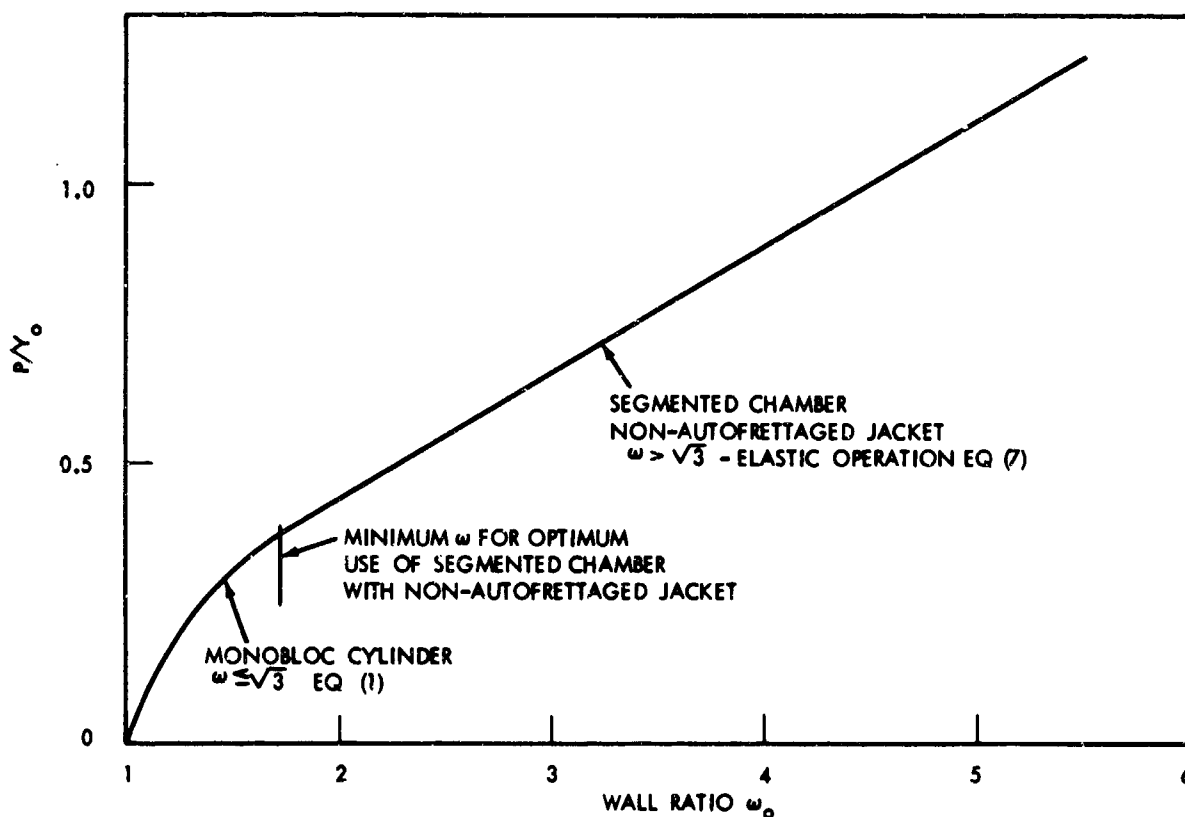

Fig. 4.  $p/Y_0$  vs Wall Ratio (Segmented Chamber Non-autofrettaged Jacket)

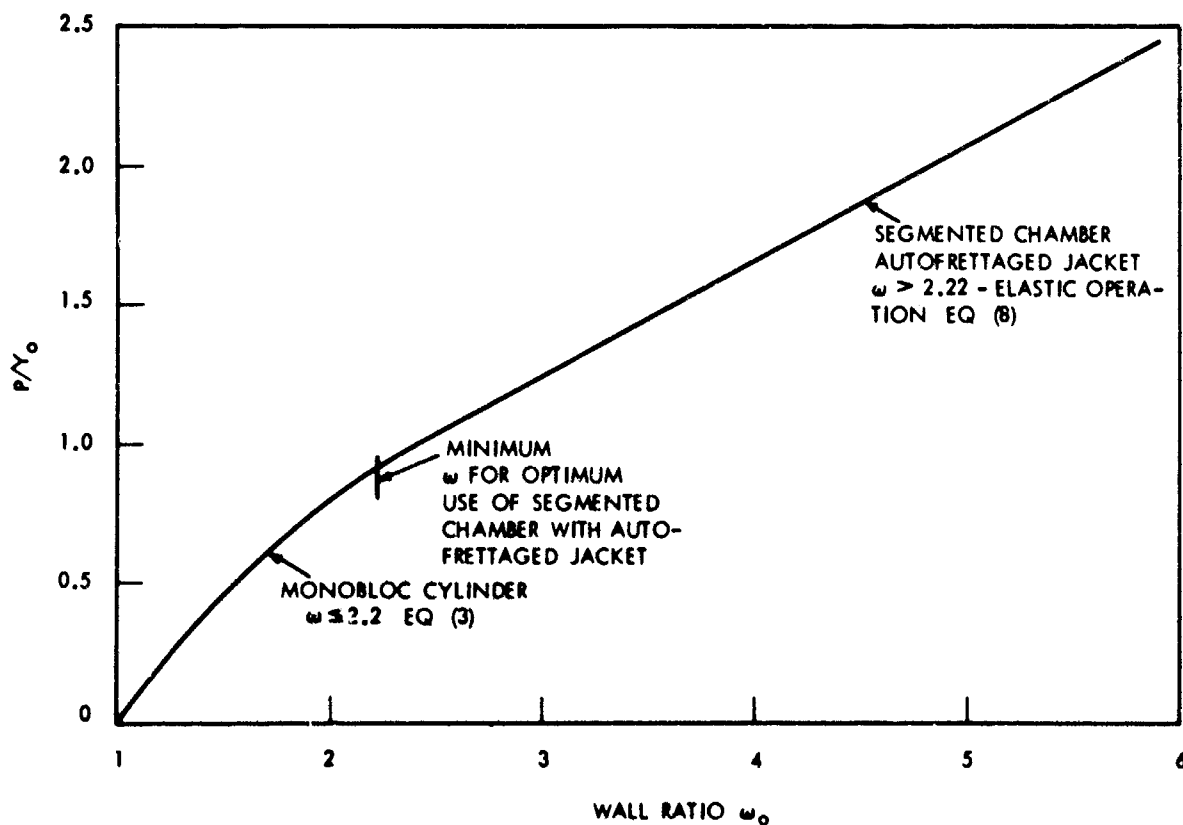

Fig. 5.  $p/Y_0$  vs Wall Ratio (Segmented Chamber Autofrettaged Jacket)

$$p = \frac{2}{\sqrt{3}} Y_0 \ln w \quad w \leq 2.22$$

For a wall ratio greater than 2.22 the maximum autofrettage pressure for elastic operation is

$$p = \frac{2Y_0(w^2-1)}{\sqrt{3} w^2} \quad w \geq 2.22$$

When an autofrettaged jacket is used with the segmented chamber construction, the optimum jacket wall ratio is 2.22.

$$\frac{d}{d_s} = \frac{w}{w_s} = 2.22$$

To autofrettage a cylinder with this wall ratio requires a pressure

$$p = 0.92 Y_0$$

Since

$$p = \frac{p_1}{w_s} = 0.92 Y_0$$

The internal pressure capability is

$$p_1 = 0.92 Y_0 w_s$$

$$= \frac{0.92 Y_0 w}{2.22}$$

$$\frac{p_1}{Y_0} = 0.415 w_0 \quad (8)$$

A plot of this equation is shown in figure 5. As can be seen, the elastic pressure capability of a segmented chamber with an



autofrettaged jacket is higher than that of any of the other systems considered and, in fact, exceeds the burst strength of a monobloc cylinder for wall ratios greater than about 3.5.

SUMMARY OF CALCULATIONS

Monobloc Cylinder

a. Elastic-non-autofrettaged

$$p/Y_0 = \frac{w^2 - 1}{\sqrt{3} w_0} \quad (1)$$

b. Elastic-autofrettaged

$$p/Y_0 = \frac{2}{\sqrt{3}} \ln w_0 \quad w_0 \leq 2.22 \quad (1a)$$

$$p/Y_0 = \frac{2(w^2 - 1)}{\sqrt{3} w_0} \quad w_0 \geq 2.22 \quad (1b)$$

c. Plastic-reverse yielding (burst strength)

$$p/Y_0 = \frac{2}{\sqrt{3}} \ln w_0 \quad w \geq 2.22 \quad (3)$$

Segmented Cylinder

a. Elastic-non-autofrettaged jacket

$$p/Y_0 = .222 w_0 \quad w_0 \geq \sqrt{3} \quad (7)$$

b. Elastic-autofrettaged jacket

$$p/Y_0 = .415 w_0 \quad w_0 \geq 2.22 \quad (8)$$

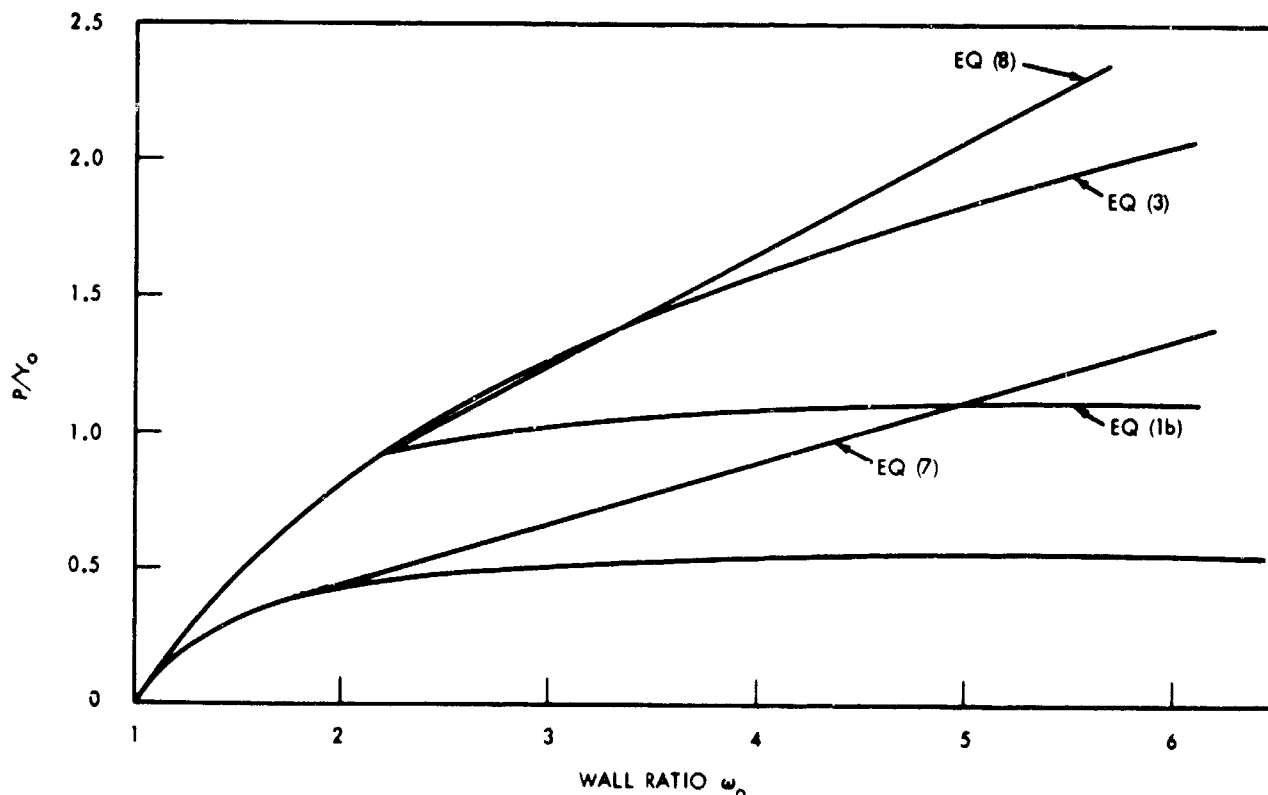

Fig. 6. Summary Plot  $p/Y_0$  vs Wall Ratio

Figure 6 shows a graphical summary of these equations. See Appendix A for a discussion of the nonelastic operation of a segmented chamber.

#### LIMITATIONS TO THE SEGMENTED CHAMBER DESIGN

In order to obtain super-pressures with the segmented chamber, it is necessary to use segments having very high compressive strengths or to maintain a compressive pre-load in the segments during the application of internal pressure. The latter approach appears limited by the same limitations that are encountered in the shrink-fit construction. Thus, the success of high pressure containment ultimately appears to rest on the use of high compressive strength segments. Several materials suggest themselves, e.g., Carboloy, the traditional material used in high pressure technology, and glass. Bridgman achieved compression strengths of  $1.5 \times 10^6$  psi in Carboloy and the compressive strengths of glass are estimated to be greater than  $10^6$  psi (ref. 4).

NOLTR 67-121

Within the compressive limits of the segments, it is theoretically possible to construct chambers of relatively large size capable of extremely high pressures. Figure 7 shows such a chamber which, it is anticipated, will contain  $10^6$  psi elastically. This design utilizes a moderate shrink-fit between the outer jacket and segmented pieces to provide some precompression of the segments. Development work is currently being conducted at the Naval Ordnance Laboratory on a chamber of these dimensions. A complete analysis of the strains developed in this chamber during pressure application for various pre-load conditions is being made. Based on the ideas discussed above, this chamber has been designed to withstand  $10^6$  psi internal pressure. It is thought that it may be scaled to larger dimensions practically and economically.

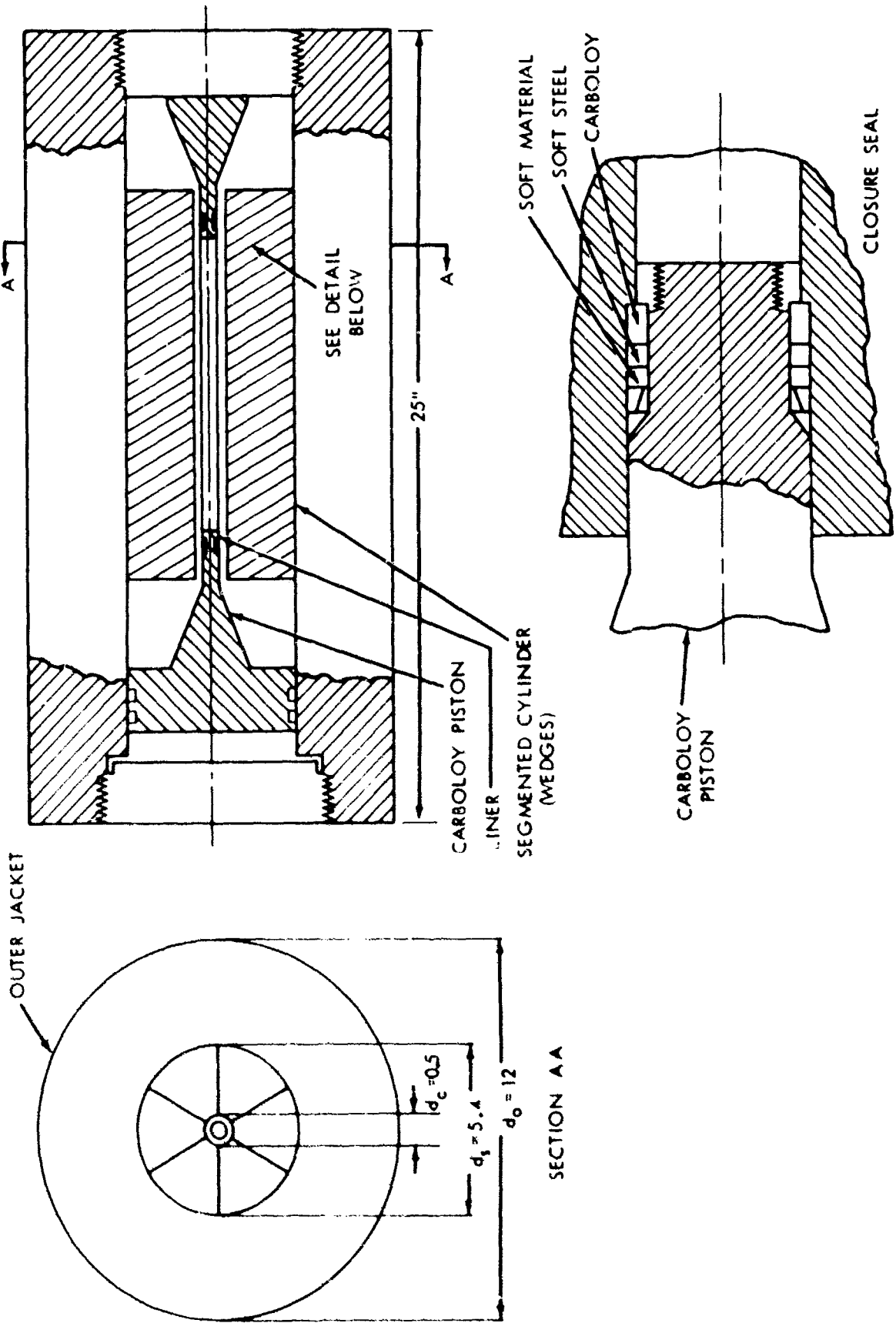

FIG. 7 DESIGN OF HIGH PRESSURE CHAMBER

REFERENCES

1. "Elastic and Plastic Stress Equations for Hollow Cylinders and Spheres Subjected to Internal and External Pressure," V. C. D. Dawson, NAVORD 6786, Feb 1960
2. Engineering Design, Joseph H. Faupel, John Wiley and Sons, New York, 1964
3. "Reverse Yielding of Fully Autofrettaged Tube of Large Wall Ratio," V. C. D. Dawson and A. E. Seigel, NOLTR 63-123, Aug 1963
4. Large Plastic Flow and Fracture, P. W. Bridgman, McGraw Hill Book Co. Inc., 1st edition, 1952
5. "High Pressure Technology," Mechanical Engineering, Dec 1965 p 14
6. Patent No. 2,554,499, T. C. Poulter, 29 May 1951

APPENDIX A

If elastic operation of the cylinder is not required, then it should be possible to use a jacket which undergoes reverse yielding. The optimum diameter ratio for this case is established as follows:

The equation that governs the performance of the jacket is equation (3)

$$p/Y_0 = \frac{2}{\sqrt{3}} \ln \frac{d}{d_s} = \frac{2}{\sqrt{3}} \ln \frac{u}{u_s} \quad (3)$$

Since

$$p = \frac{p_1}{u_s} \quad (4)$$

$$\frac{p_1}{Y_0} = \frac{2}{\sqrt{3}} u_s \ln \frac{u}{u_s} \quad (9)$$

$$\frac{dp_1}{du_s} = \frac{2}{\sqrt{3}} \left[ \ln \frac{u}{u_s} - \frac{u}{u_s} \right] = 0$$

$$\ln \frac{u}{u_s} = 1$$

or

$$\frac{u}{u_s} = e$$

Substituting this back into (9) gives

$$\frac{p_1}{Y_0} = \frac{2}{\sqrt{3}} \frac{w}{e} \ln \frac{w(e)}{w_0}$$

$$= \frac{2}{\sqrt{3}} \frac{w}{e}$$

$$= 0.424 w_0$$

The gain in going to a nonelastic reverse yielded jacket is extremely small. When one considers the pressure requirements to autofrettage during manufacture, it would seem far more desirable to always design for elastic operation (equation (8)) where the autofrettage pressure for the jacket is

$$p = 0.92 Y_0.$$

**UNCLASSIFIED**

Security Classification

**DOCUMENT CONTROL DATA - R & D**

*Security classification of title, body of abstract and indexing annotation must be entered when the overall report is classified*

1. ORIGINATING ACTIVITY (Corporate author) <b>U. S. Naval Ordnance Laboratory White Oak, Silver Spring, Maryland</b>		2a. REPORT SECURITY CLASSIFICATION <b>Unclassified</b>	
		2b. GROUP	
3. REPORT TITLE <b>HIGH PRESSURE CHAMBER DESIGN</b>			
4. DESCRIPTIVE NOTES (Type of report and inclusive dates)			
5. AUTHOR(S) (First name, middle initial, last name) <b>Victor C. D. Dawson Arnold E. Seigel</b>			
6. REPORT DATE <b>1 August 1967</b>		7a. TOTAL NO. OF PAGES <b>22</b>	7b. NO. OF REFS <b>6</b>
8a. CONTRACT OR GRANT NO.		9a. ORIGINATOR'S REPORT NUMBER(S) <b>NOLTR 67-121</b>	
b. PROJECT NO.		9b. OTHER REPORT NO(S) (Any other numbers that may be assigned this report)	
c.			
d.			
10. DISTRIBUTION STATEMENT <b>Distribution of this document is unlimited</b>			
11. SUPPLEMENTARY NOTES		12. SPONSORING MILITARY ACTIVITY	
13. ABSTRACT <p>The pressure containment capability of a monobloc cylindrical chamber that remains elastic is limited by the mechanical strength of the chamber material to values of about 100,000 pounds per square inch. Higher pressures can be contained by using a shrink-fit construction or autofrettage and these techniques provide approximately twice the pressure containment capability that can be obtained with the monobloc construction. This report describes and analyzes a segmented chamber that greatly extends the high pressure capability of a cylindrical chamber in the elastic range.</p>			



**UNCLASSIFIED**

Security Classification

14. KEY WORDS	LINK A		LINK B		LINK C	
	ROLE	WT	ROLE	WT	ROLE	WT
High pressure Autofrettage Cylinder Segmented cylinder						

**UNCLASSIFIED**

Security Classification