

ADVANCED RESEARCH PROJECTS AGENCY

Contract ABRA 50-587

Contract Report No. ARPA-12

THE DIRECT SYNTHESIS OF
ORGANOGERMANIUM TRIHALIDES

October 1957

By
S. Vasiliou and E. G. Rochow

DDC
NOV 16 1957
RESEARCH DIVISION

AD 661202



DIVISION OF ENGINEERING AND APPLIED PHYSICS
HARVARD UNIVERSITY - CAMBRIDGE, MASSACHUSETTS

THE DIRECT SYNTHESIS OF ORGANOCERMANIUM TRIHALIDES

by

E. Vassiliou and E. G. Rochow

Technical Report No. ARPA-32 Contract ARPA SD-88

Reproduction in whole or in part is permitted by the U. S. Government. Distribution of this document is unlimited.

September 1967

Submitted to:

Advanced Research Projects Agency

The Department of Defense

Division of Engineering and Applied Physics

Harvard University

Cambridge, Massachusetts

THE DIRECT SYNTHESIS OF ORGANOGERMANIUM TRIHALIDES

ABSTRACT

n-Alkyl chlorides above propyl chloride react with germanium in the presence of copper as catalyst at 375-425°C to yield n- and i-alkylgermanium trihalides. The by-products of this reaction are the corresponding n- and i-alkenes. Chlorocyclohexane shows a rather poor yield. Phenyl germanium trichloride can be prepared by the action of germanium tetrachloride and phenyl chloride on germanium under similar conditions.

THE DIRECT SYNTHESIS OF ORGANOGERMANIUM TRIHALIDES

E. Vassiliou* and E. G. Rochow

Mallinckrodt Laboratory, Department of Chemistry,
Harvard University, Cambridge, Massachusetts

The direct synthesis of organogermanium compounds has mostly been employed for the preparation of the lower dialkyl and diaryl germanium dihalides¹, with only a few exceptions²⁻⁴. Other methods have been used for the preparation of the organogermanium trihalides⁵, including dealkylation reactions^{6,7}, cleavage reactions with halogen⁸, hydrogermylation reactions⁹⁻¹¹, and conversion reactions¹²⁻¹⁴. Most of these methods yield⁵ mixtures, and the products require careful purification.

The observation that organogermanium trihalides can be prepared by the direct reaction of alkyl halides with germanium metal in the presence of catalysts is not new². However, the poor yield of propyl germanium trichloride prepared by Rochow, Ditschenko and West² employing this method in 1951 was discouraging, and no further attention had been given to this technique since then.

In the present work, a series of experiments showed that heavier n-chloroalkanes give yields in the region of 50% (see Table 1). With butyl- and amyl- chlorides the product of reaction was contaminated only with starting material, and no by-product was found. With hexyl- to decyl- chlorides relatively large amounts of by-products were condensed, the boiling points of which were much lower than those of the starting materials. All by-products were soluble in an equal volume of concentrated sulfuric

* Present address: E.I. du Pont de Nemours & Company, Development Department, Wilmington, Delaware.

TABLE 1

ORGANOGERMANIUM TRIHALIDES PREPARED AND RELATED BY-PRODUCTS

Compound Prepared	RCl reacted (gr.)	RGeCl ₃ produced (gr.)	Chlorine Analysis		Yield (%)	C _n H _n produced (gr.)	Yield
			found	Calc.			
C ₄ H ₉ GeCl ₃	94	29	44.8	45.0	38	--	--
C ₅ H ₁₁ GeCl ₃	35.5	17.4	42.1	42.5	63	--	--
C ₆ H ₁₃ GeCl ₃	41.8	16.1	39.9	40.2	47	7.7	40
C ₇ H ₁₅ GeCl ₃	36.5	13	37.9	38.3	52	16.8	95
C ₈ H ₁₇ GeCl ₃	35.6	11.4	36.9	36.4	48	17	95
C ₉ H ₁₉ GeCl ₃	34.8	12.5	34.1	34.7	53	17.5	97
C ₁₀ H ₂₁ GeCl ₃	32.2	11.1	32.8	33.2	57	17	100
C ₆ H ₁₁ GeCl ₃	56	5.9	39.9	40.5	14	34.8	134*

*See text

acid, and also after being dissolved in absolute alcohol could react immediately with a 1% solution of potassium permanganate. This behavior indicated¹⁵ the presence of at least one double bond. The probable configuration of the by-product therefore would be either $RCH=CH_2$ or $R'CH=CHCH_3$, or a mixture of both. Since the strong infrared bands of all by-products were almost identical and lying between $900-1000\text{ cm}^{-1}$ and $2800-3100\text{ cm}^{-1}$, those two regions were studied. For the configuration $RCH=CH_2$ one would expect¹⁶ one band at $905-915\text{ cm}^{-1}$ (CH_2 out-of-plane deformation), one band at $985-995\text{ cm}^{-1}$ (CH out-of-plane deformation), and bands in the region of 3000 cm^{-1} due to CH stretching. Regarding the $R'CH=CHCH_3$ configuration, the expected bands should be at $960-970\text{ cm}^{-1}$ (CH out-of-plane deformation) for the trans form, near 690 cm^{-1} (CH out-of-plane deformation) for the cis form, and in the region of 3000 cm^{-1} (CH stretching) for both. The bands observed (figures 1 and 2 for the case of heptenes; the spectra of the other members of this series are not given here since they are almost identical) are:

- 1) One couple located at 910 and 995 cm^{-1} (the one lying at 910 being considerably stronger than that at 995), assigned to 1-heptene,
- 2) One single band at 965 cm^{-1} assigned to the trans form of 2-heptene, and
- 3) A number of bands lying between 2800 and 3100 cm^{-1} , assigned to both.

A comparison of the spectra with the corresponding A.P.I. curves verified the above. The following A.P.I. curves were employed for comparison:

- 1) 1-hexene (API 472), 2-hexene (API 727, 1057 for cis, API 620 for trans),
- 2) 1-heptene (API 473), 2-heptene (API 713 for 60% cis, 40% trans, API 714 for 90% trans, 10% cis),
- 3) 1-octene (API 474), 2-octene (API 31 for cis - trans),

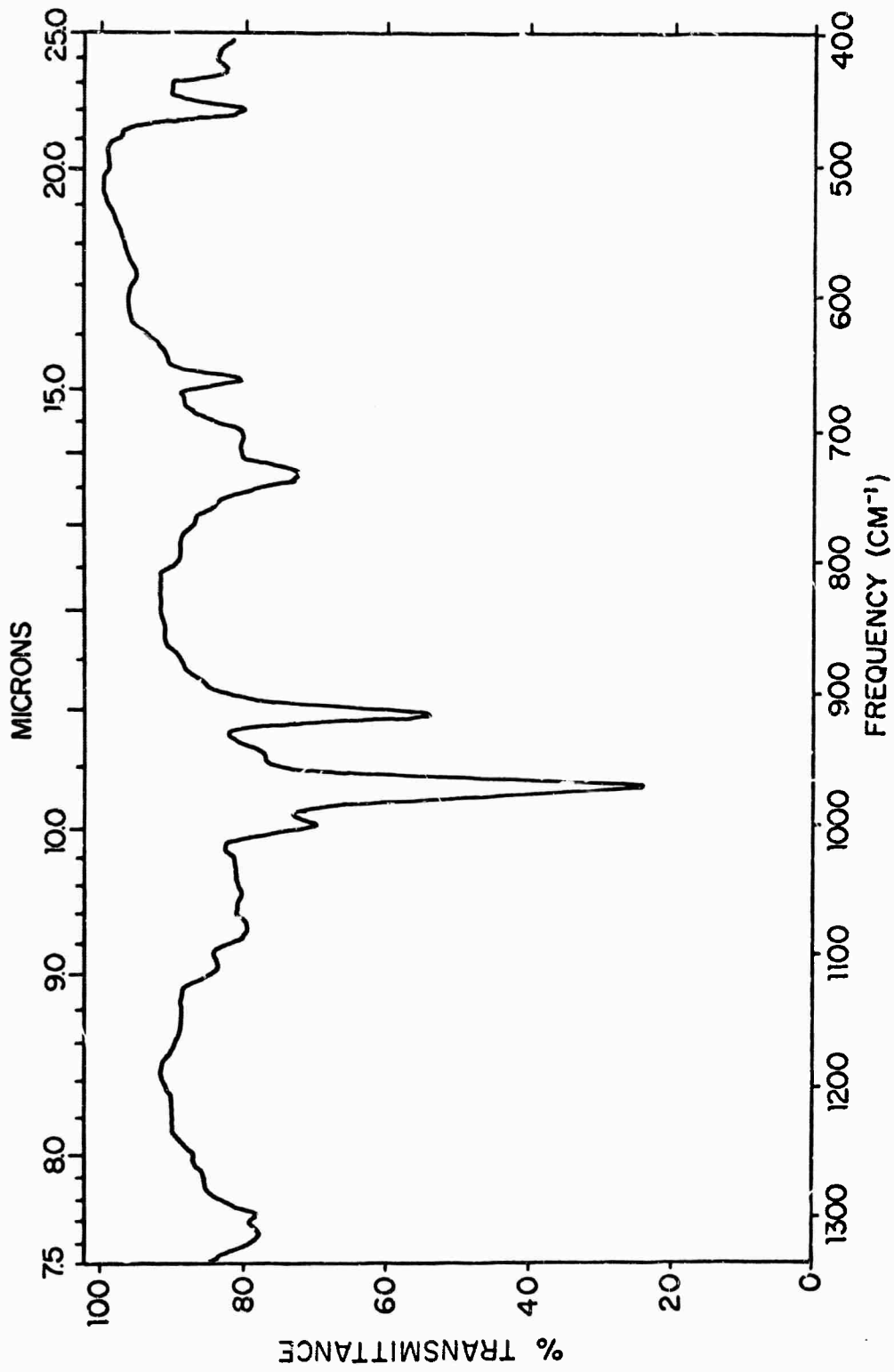

FIG. 1 MIXTURE OF 1-HEPTENE AND 2-HEPTENE (BY-PRODUCT)

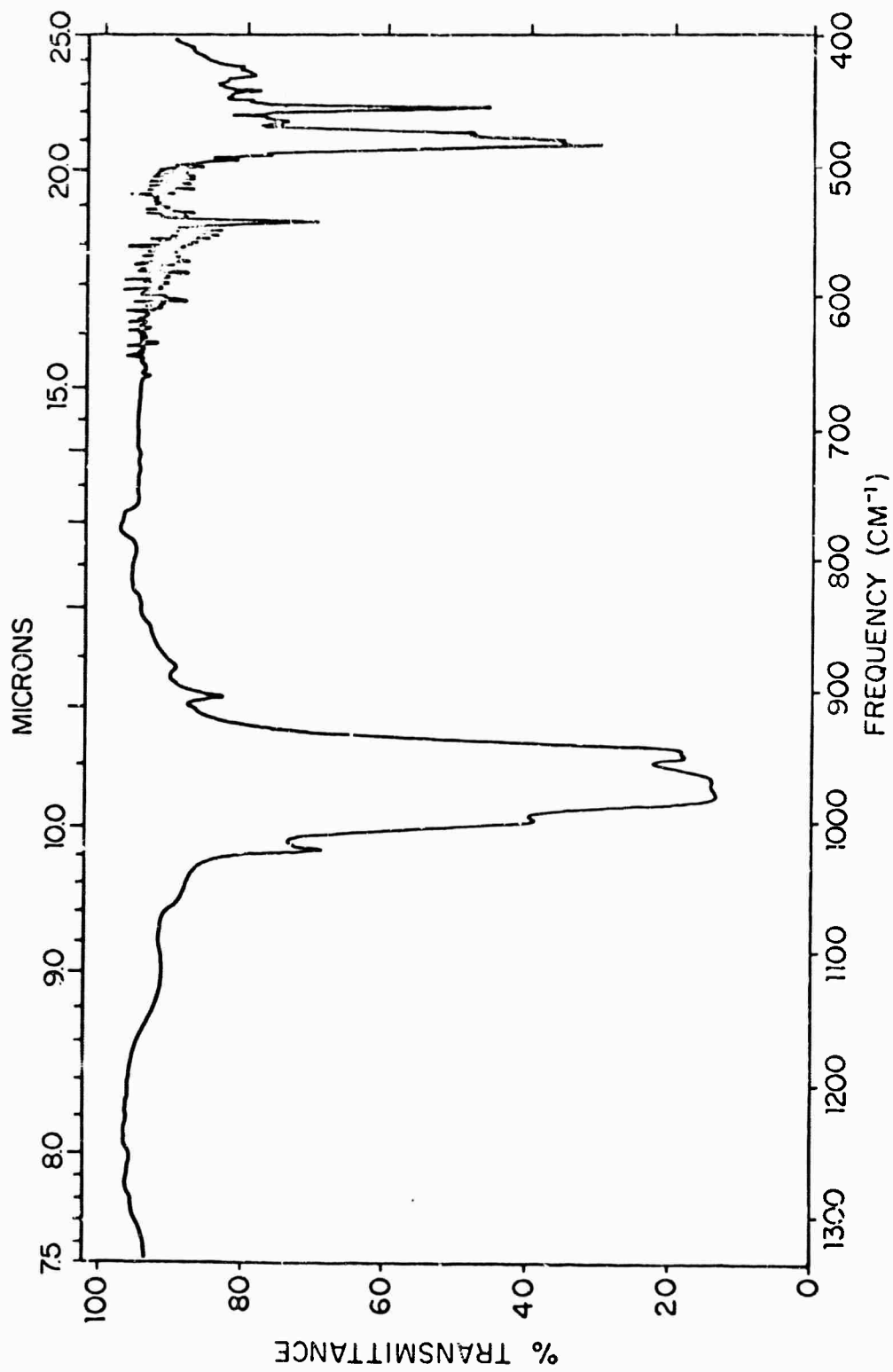

FIG. 2 MIXTURE OF 1-HEPTENE AND 2-HEPTENE (BY-PRODUCT)

- 4) 1-nomene (API 1067), and
- 5) 1-decene (API 1070)

Therefore, it can be concluded that both 1- and 2- alkenes are produced during the course of the direct synthesis of the heavier alkyl trichlorogermanes. It can also be understood now why in the case of butyl- and amyl- chlorides no by-product was observed. This is because the butenes boil below 0°C and the pentenes around or just above room temperature.

Vapor-phase chromatography experiments showed that in this series of compounds (butyl-to decyl) approximately one third of the starting material does not react. It also showed that no other by-products are formed, apart from the corresponding alkenes.

Regarding the compounds $C_n H_{2n+1} GeCl_3$ (n= 4 to 10), the VPC column employed (see experimental part) could separate completely the iso- from the normal compound when n= 4 or 5, but as n increases, the separation ability declines to the point that when n= 10 no separation occurred. In those cases when separation takes place, the ratio iso:normal is 1:3 to 1:4, approximately. This separation also occurred in the case of the two hexenes, showing a ratio of 1:1.

By partial distillation in vacuum the n- and i- alkyl trichlorogermanes could not be separated from each other, but mixtures of different proportions were obtained. Analysis for the chlorine content of the different fractions yielded identical results.

Nuclear magnetic resonance spectra could not give additional information about the mixtures, since even in the simplest case (of butyl

trichlorogermane) the multiplets were overlapping.

The infrared spectra of the mixtures consisting of normal and iso-alkyl trichlorogermanes are given in figures 3-9.

The overall reaction, therefore, takes place according to the scheme:

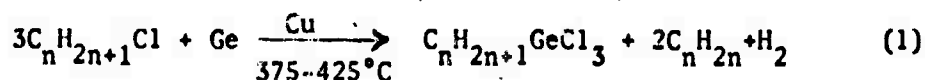

The mechanism of formation of the alkene and iso-germane could be explained by the formation of an intermediate secondary free radical at the position of the second carbon atom. The appearance of some $GeCl_2$ at both ends of the reaction tube, as well as in some other experiments which will be discussed later, indicates that an additional reaction can take place, too:

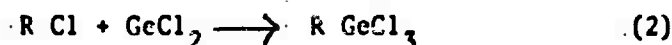

The formation of germanium dichloride could take place through chlorination of germanium by the chlorohydrocarbon. This reaction seems to be very similar to that of the preparation¹⁷⁻¹⁸ of germanium chloroform, which most probably takes place in two steps (see for example ref. 19):

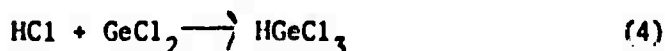
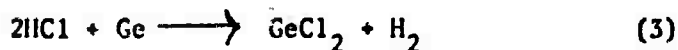

In order to calculate the yields of the germanes and the by-products, reaction (1) was assumed to take place. The amount of the unreacted alkyl chloride was also taken into account. If this had not been taken into account, however, the yields of the germanes would be approximately 2/3 of those shown in Table 1.

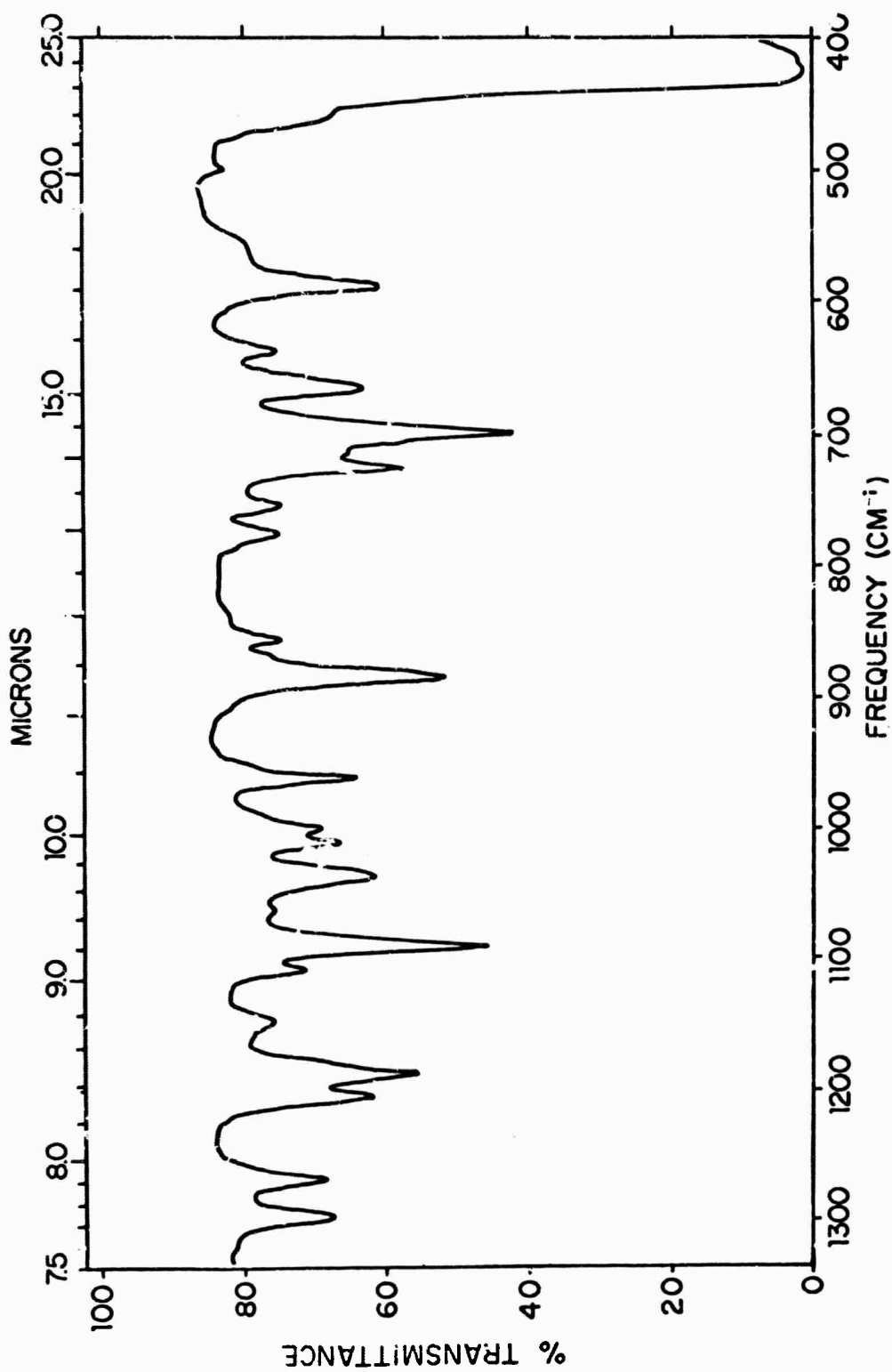

FIG. 3 MIXTURE OF n- AND i-BUTYL TRICHLORGERMANES

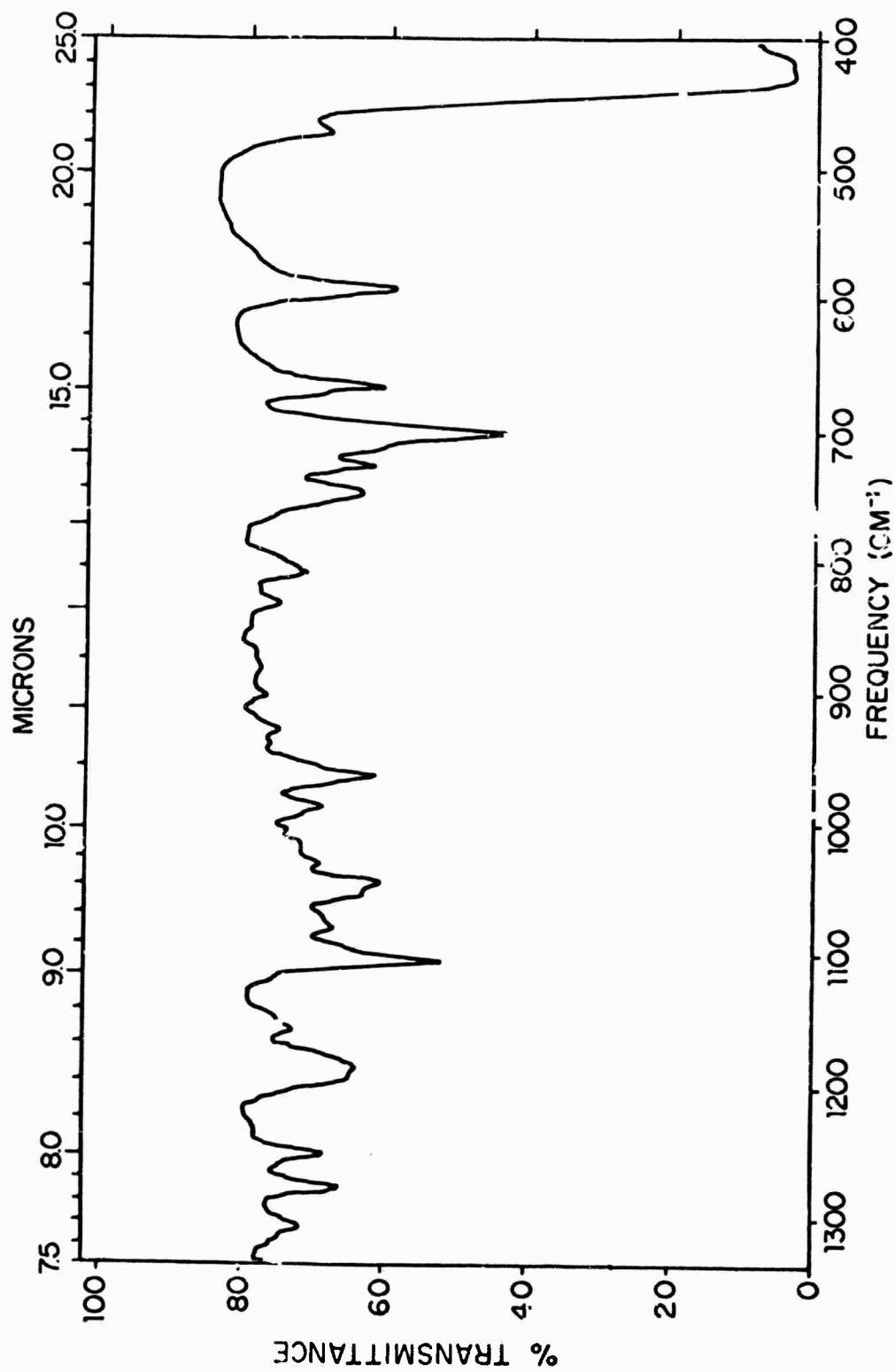

FIG. 4 MIXTURE OF n-AND i-AMYL TRICHLORGERMANES

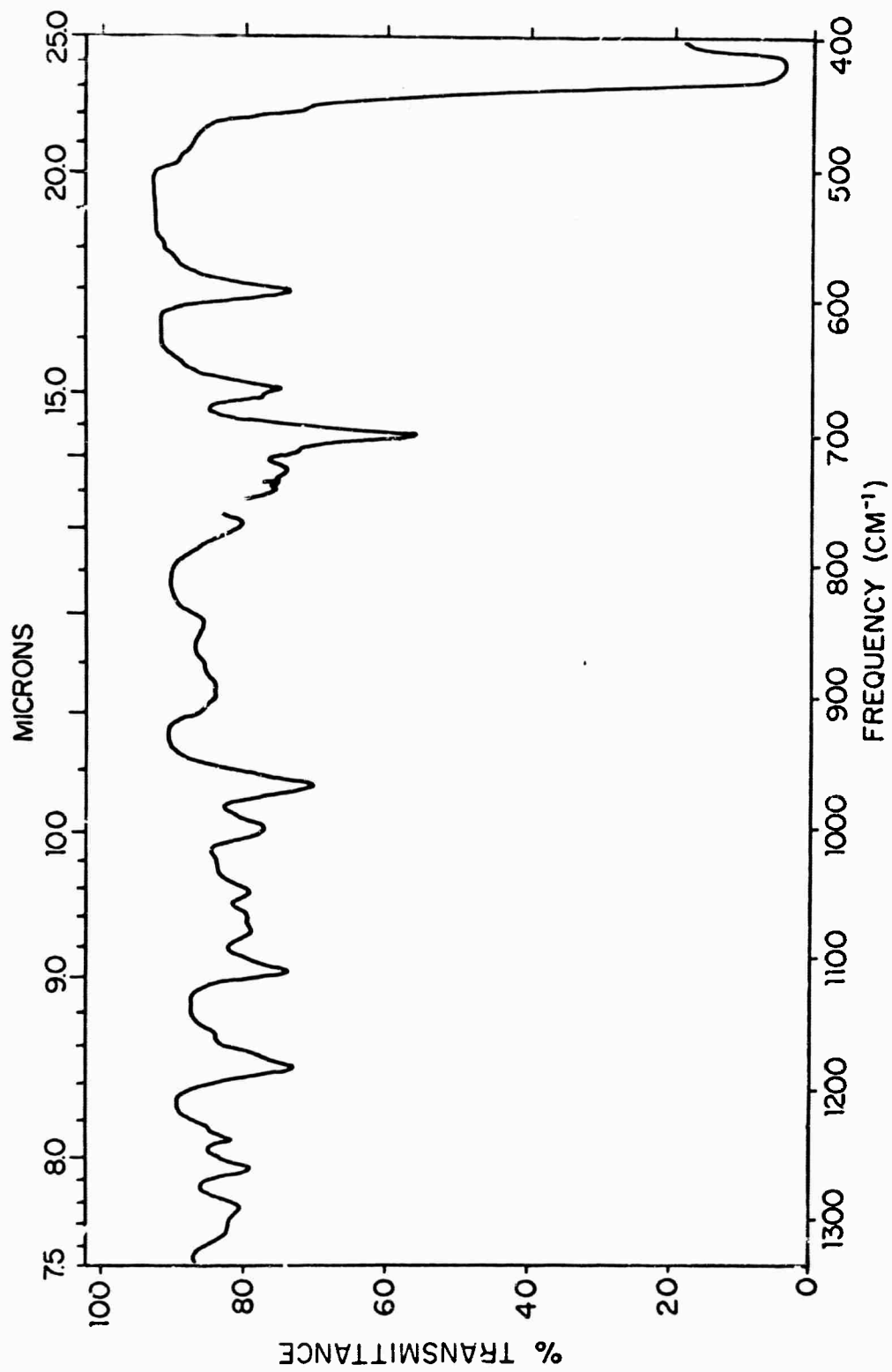

FIG. 5 MIXTURE OF n-AND i-HEXYL TRICHLOROETHERMANES

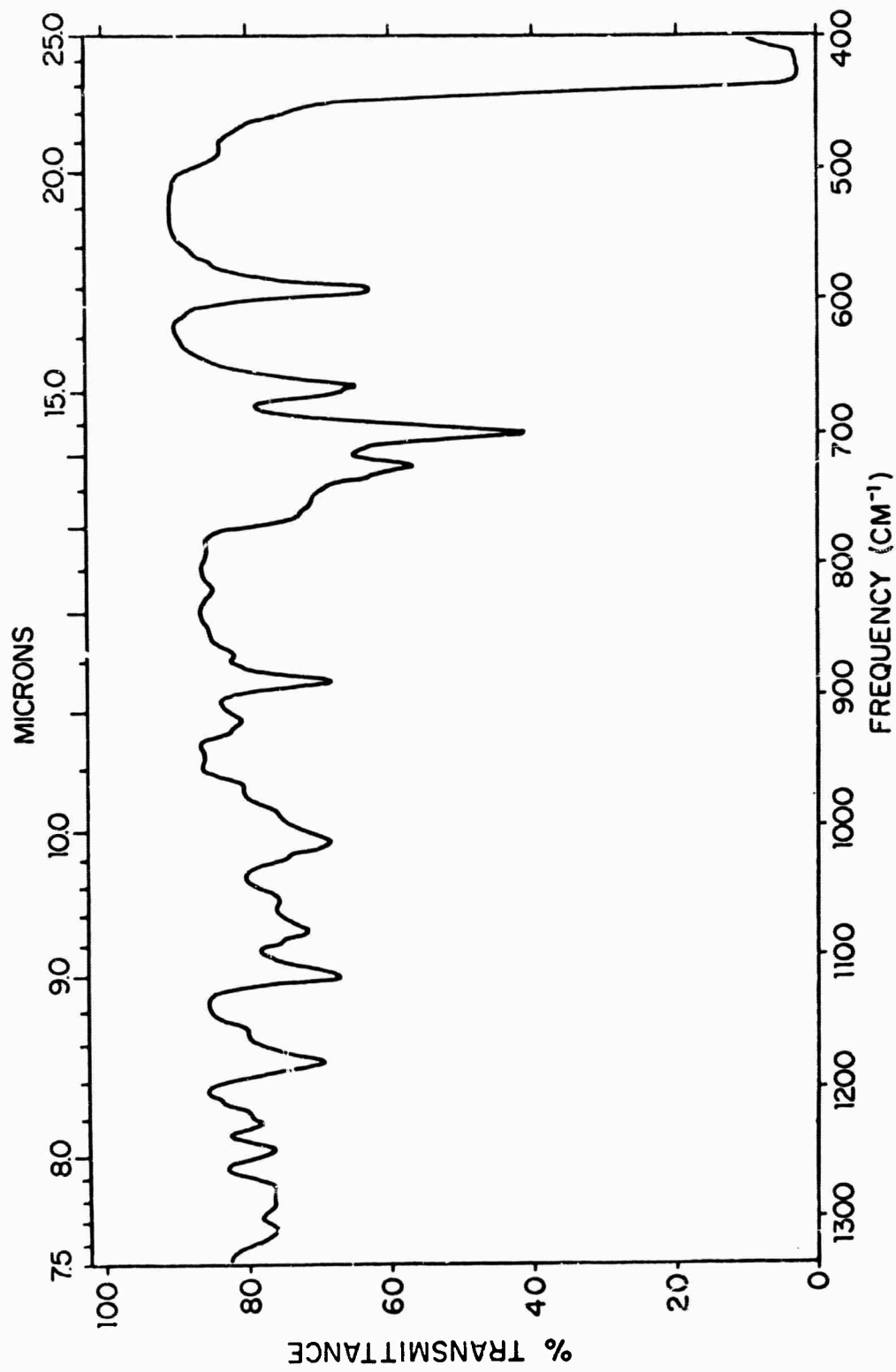

FIG. 6. MIXTURE OF n- AND i-HEPTYL TRICHLORGERMANES

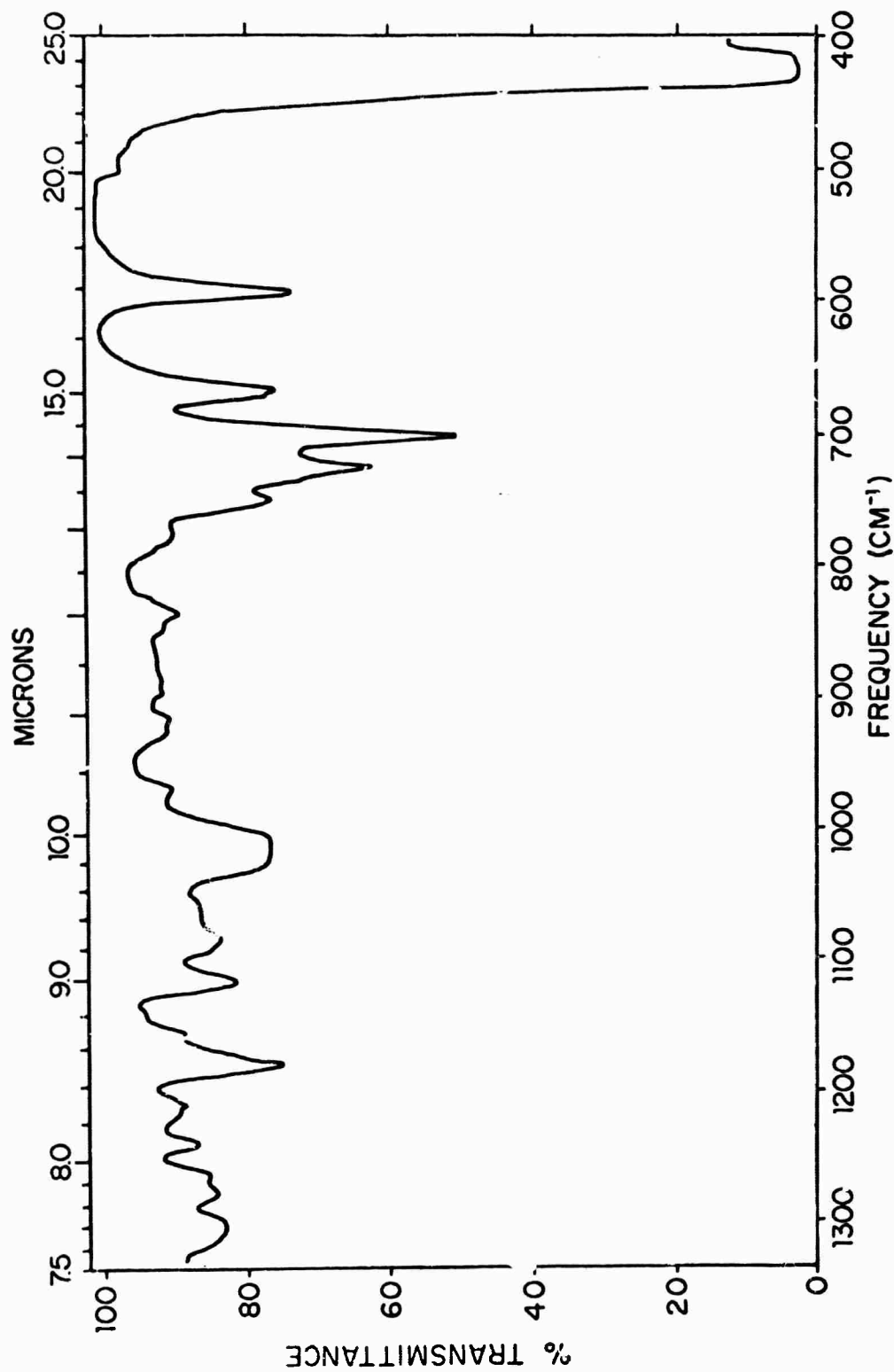

FIG. 7 MIXTURE OF *n*-AND *i*-OCTYL TRICHLOROGERMANES

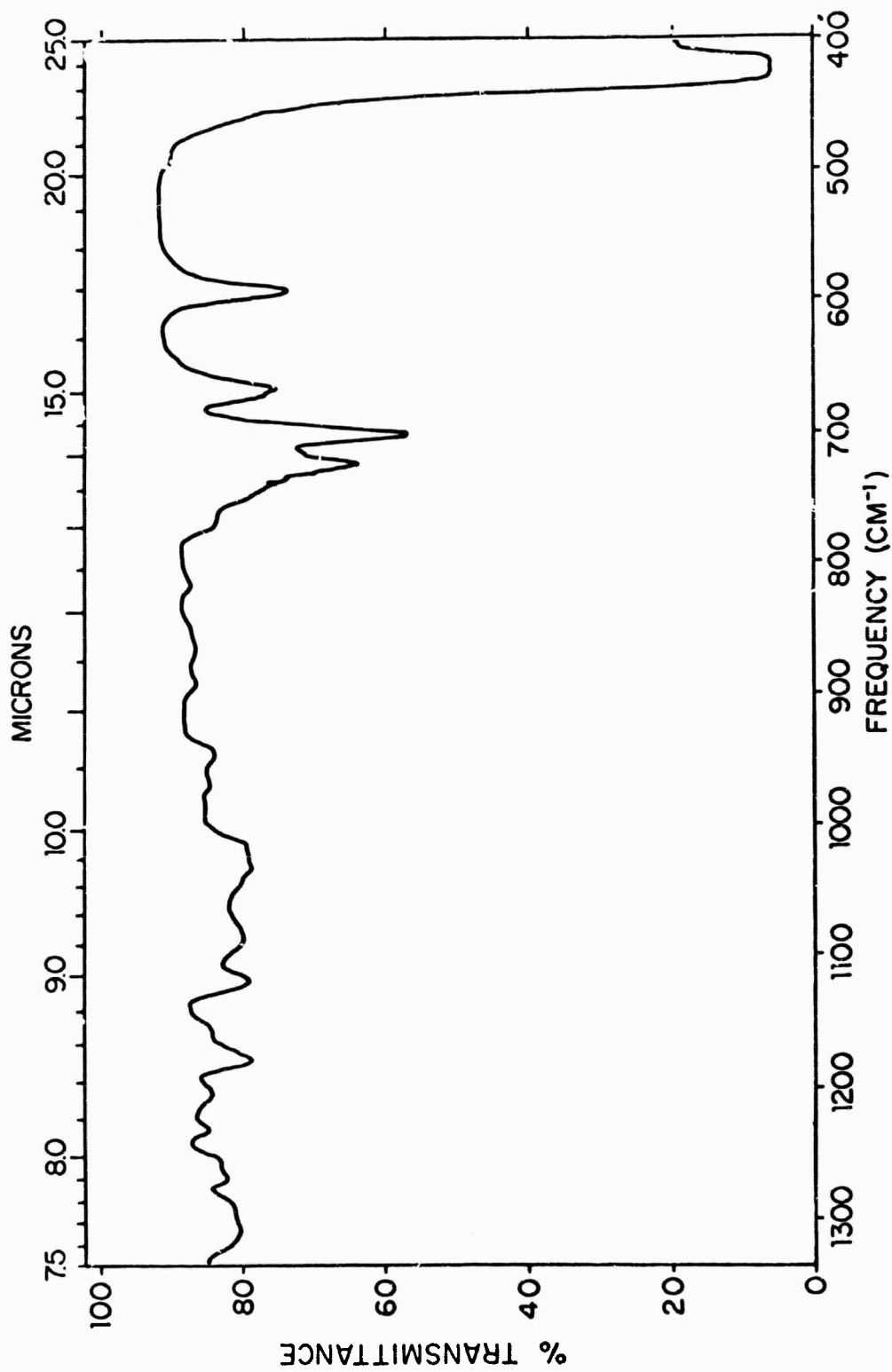

FIG. 8 MIXTURE OF n-AND i- NONYLTRICHLORGERMANES

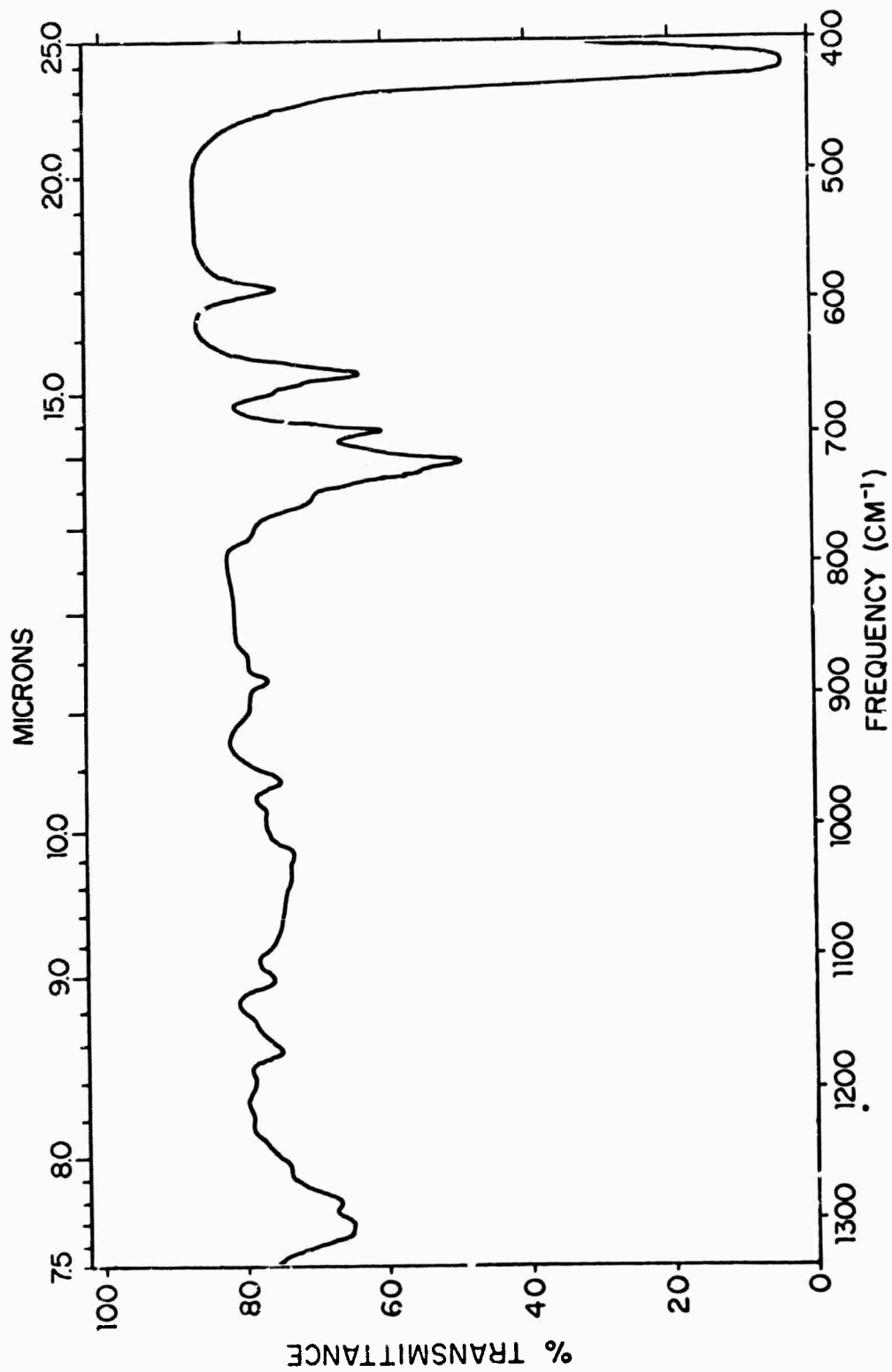
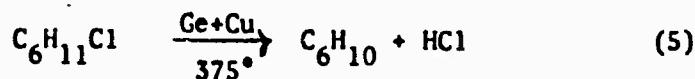

FIG. 9 MIXTURE OF *n*-AND *i*-DECYLTRICHLOROETHANES

It can be seen that the alkyl trichlorogermanes are produced with a yield of approximately 50%, and that the corresponding alkenes appear in almost the theoretical yield.

Cyclochlorohexane gives a much smaller yield of germane than the linear aliphatic chlorides, and the part that does not combine with germanium loses HCl and almost quantitatively becomes cyclohexene. If the amount of that part of cyclochlorohexane that reacted with germanium is taken into account, the yield of the reaction



is 96%. The yield of 134% stated in table 1 means that the part of cyclochlorohexane which does not react with germanium reacts further according to equation (5).

The cyclohexene was recognized as such by the comparison of its infrared spectrum with the spectrum of pure cyclohexene. Additionally, the VPC shows only one compound, the boiling point of which is 82-83°C.

In this case the cyclohexyltrichlorogermane which is produced is a pure compound, since any secondary free radicals that could be formed during the reaction are equivalent. The same, of course, is valid for the by-product, cyclohexene. The i.r. spectrum of the cyclohexyltrichlorogermane is shown in figure 10.

Phenyl trichlorogermane was produced by employing a different technique. Since silver is considered a better catalyst than copper for the direct synthesis of aryl chlorogermanes, the reaction tube was filled up with a mixture of germanium and silver powders suspended on glass wool. The temperature was kept constant at 450°C. Fifty cc of a mixture of GeCl_4 and $\text{C}_6\text{H}_5\text{Cl}$ reacted according to the left part of the equation

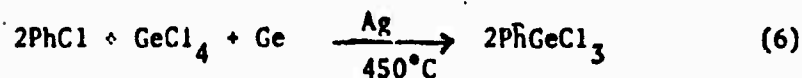

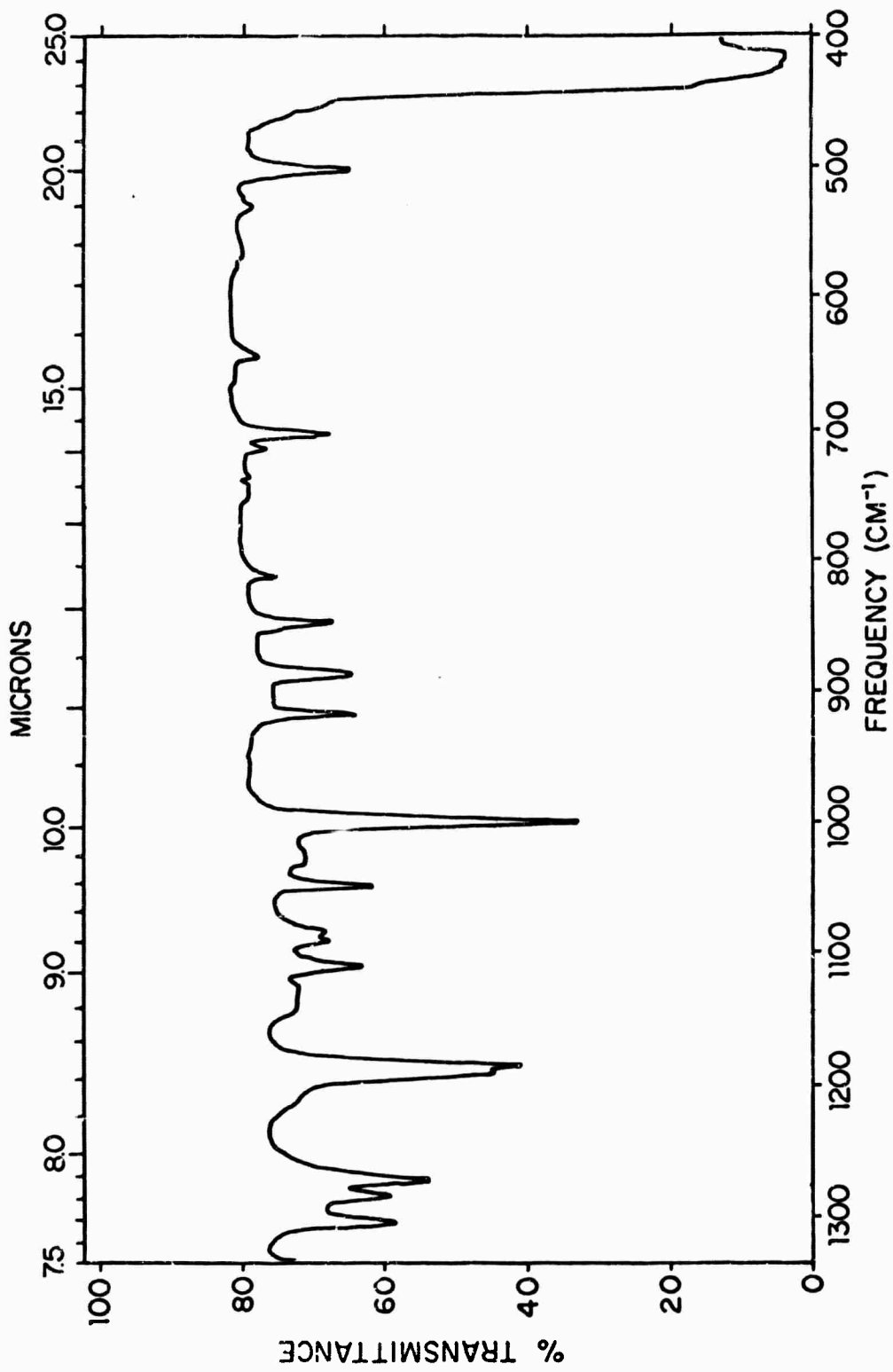

FIG. 10 CYCLOHEXYL TRICHLOROGERMANE

when allowed to pass through the tube steadily over a period of 20 hours.

The products of reaction were GeCl_2 , PhGeCl_3 , and unreacted PhCl and GeCl_4 . Vapor-phase chromatography showed no by-products. The i.r. spectrum of this mixture is shown in figure 11. The broad band at $\sim 880 \text{ cm}^{-1}$ is most probably due to hydrolysis products.

EXPERIMENTAL

Apparatus

The apparatus for the direct synthesis of organogermanium trihalides consisted of a reaction tube 2 cm in diameter and 50 cm long filled with a mixture of germanium powder and the proper catalyst. For each hydrocarbon halide a new tube containing fresh germanium and catalyst was used. For the aliphatic series the catalyst was copper powder which had previously been reduced under hydrogen at 350°C . The mixture (10 g germanium and 10 g copper) was suspended on glass wool, and occupied a length of the tube equal to 20 cm. The tube was mounted in a horizontal furnace and the temperature was measured by means of a Chromel-Alumel thermocouple protected by a pyrex tube of small diameter which was permanently fixed in the reaction tube so that the junction of the thermocouple corresponded to the middle of the furnace. Since the length of the furnace was twice of the active part of the reaction tube, the temperature drop toward the two ends of the reaction region was not excessive. Any heat loss was reduced by some glass wool in the reaction tube at both ends of the furnace.

The liquid reagent was injected directly into the tube by means of 50 cc hypodermic syringe provided with a long needle and mounted on a special screw-drive mechanism so that it could automatically deliver its

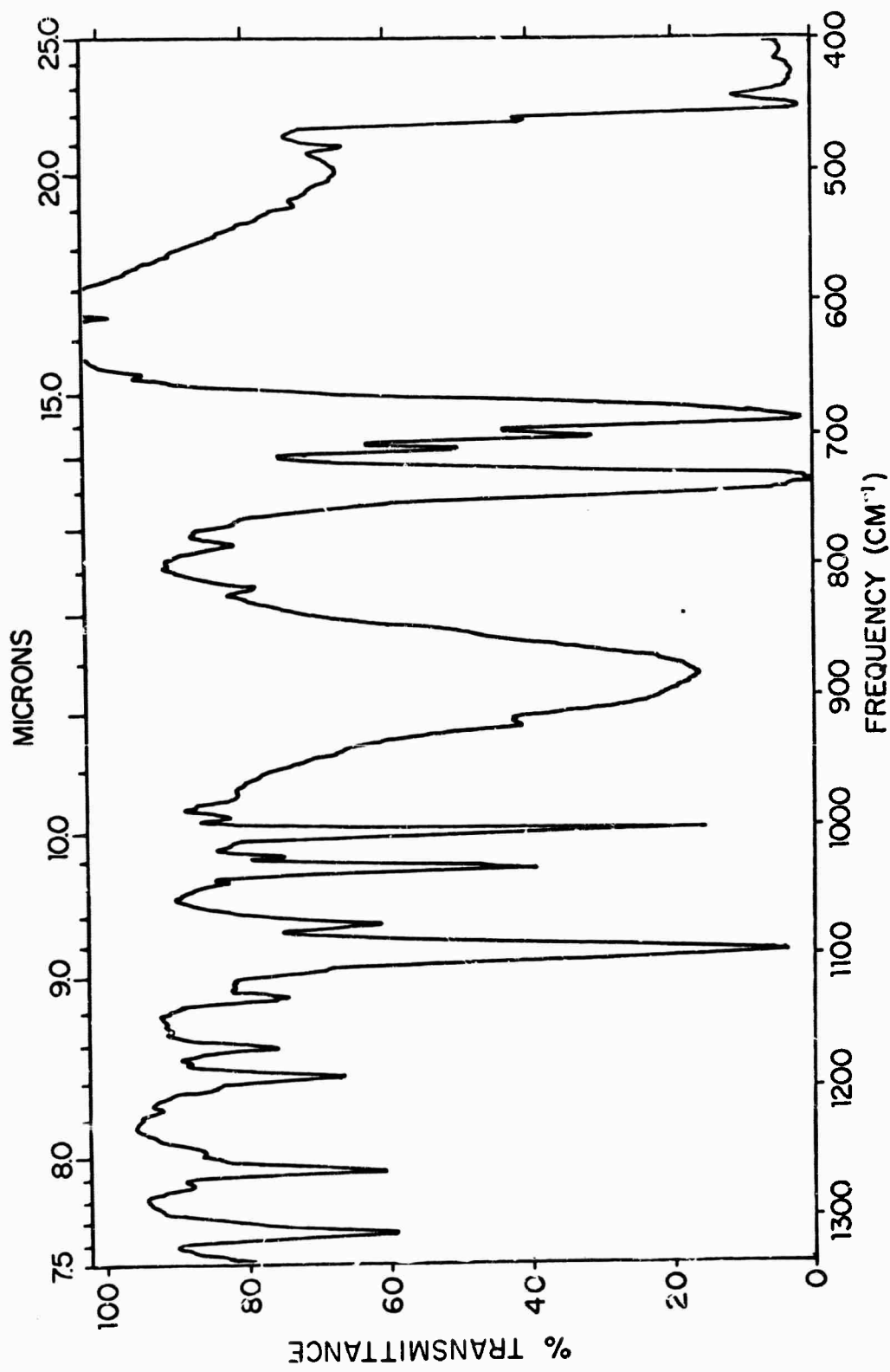

FIG. 11 PHENYL TRICHLORGERMANE (PROBABLY PARTIALLY HYDROLYZED)

contents in 20 hours. Other systems of reagent feeding, such as that of evaporation, were found to be much less efficient, since the flow rate could not easily be controlled.

The products of reaction were condensed at the other end of the tube in a 250 ml flask through a water-cooled condenser. The flask was provided with an outlet leading to a T-shaped junction through which dry nitrogen was passed toward a trap containing mineral oil. This arrangement allowed the presence of an inert atmosphere without interfering with the flow rate of the reagent or the pressure of the system, which remained at the atmospheric level. The apparatus is schematically represented in figure 12.

Procedure

After the high-temperature reactions, the condensates initially were distilled under atmospheric pressure. The residues then were redistilled in vacuum. The different fractions could be recognized by a combination of techniques such as infrared spectroscopy, vapor-phase chromatography, chemical analysis, etc.

Reagents

The following reagents were used:

- (a) Germanium powder (kindly provided by the Eagle-Picher Company through the Germanium Research Committee).
- (b) Copper powder (Fisher, electrolytically purified) which was reduced by hydrogen.
- (c) Silver powder (Fisher, cat. No. S-167).
- (d) Hydrocarbon halides RCl (Eastman Organic Chemicals), where R is

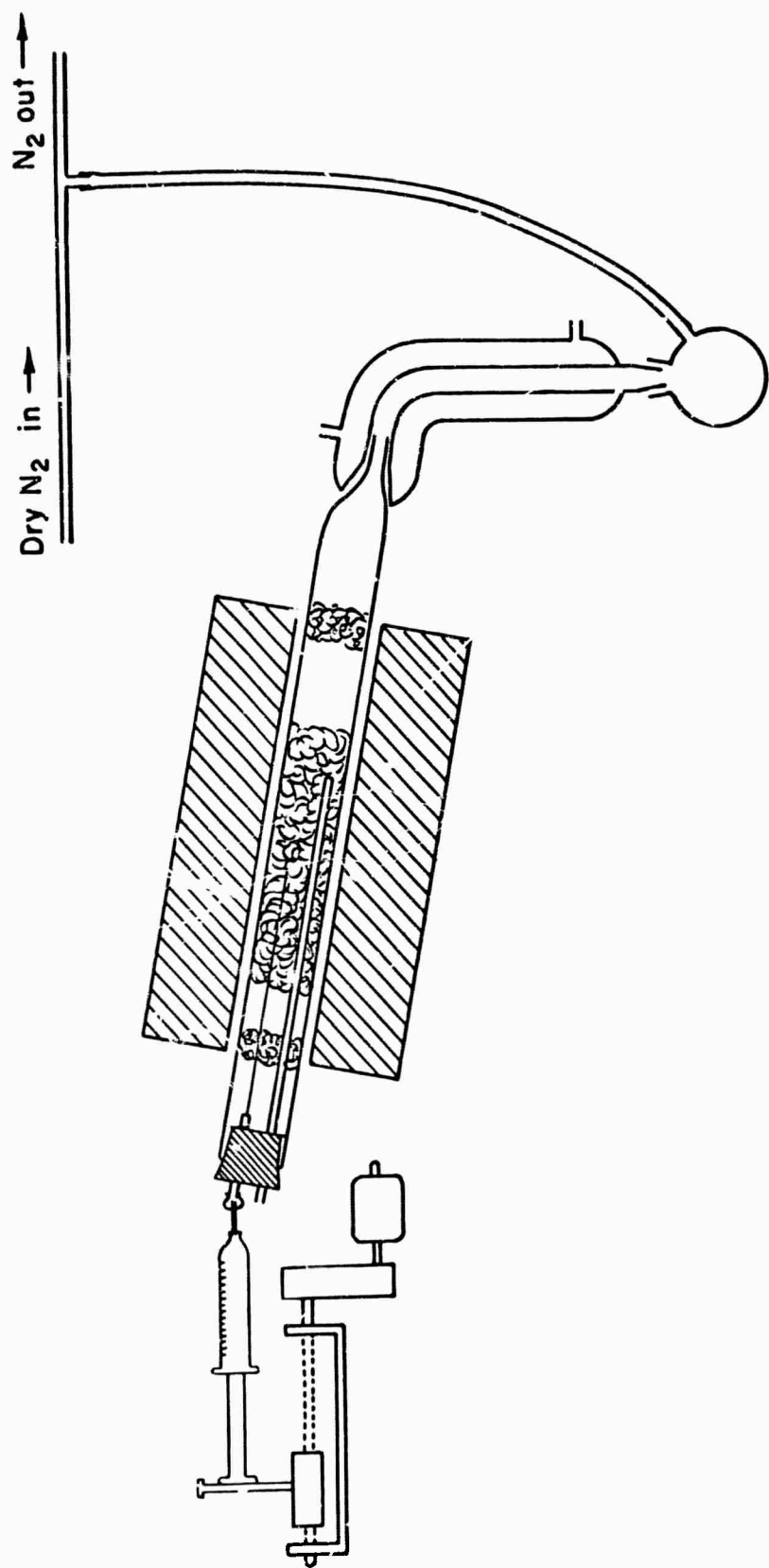

FIGURE 12

butyl-, amyl-, hexyl-, cyclohexyl-, phenyl-, heptyl-, octyl-, nonyl-, and decyl-.

(e) GeCl_4 , which was prepared by chlorination of germanium powder. Residual chlorine was removed²⁰ with Hg_2Cl_2 , and residual HCl was removed with anhydrous sodium carbonate. The germanium tetrachloride was then distilled under atmospheric pressure.

Analysis

A few methods were tried for the quantitative determination of hydrolysable chlorine in the product of reaction. The most effective, accurate, and fast method was found to be the following:

Approximately 0.3 g. of organometallic compound was weighed accurately and dissolved in 50 cc of absolute alcohol. (It was found that compounds containing alkyls heavier than the hexyl- group required 100-150 cc of alcohol.) Then an excess of ca. 2N silver nitrate solution was added drop-wise under continuous stirring. The precipitate was filtered, washed with absolute alcohol, dried at 120°C for 2 hours, and then weighed as AgCl .

The method was tested by determining the chlorine content of diphenyldichlorogermane (Alfa Inorganics, Inc.). The experimental values were 0.1 to 0.2% lower than the calculated values, due probably to hydrolysis during standing, even in a well-closed container.

Infrared Spectra

The infrared spectra of the products and the by-products were taken in the region $400\text{-}4000\text{ cm}^{-1}$ by means of a Perkin-Elmer model 337 spectrometer. A liquid film of the compound was used between KBr windows.

Vapor-Phase Chromatography

An F.S.M. model 609 flame ionization detector was used for the VPC measurements. The column was an 8 ft. 5% silicone gum GE-XE-60 on 60-80 S. 609.

Nuclear Magnetic Resonance

The N.M.R. spectra of some of the compounds were taken using a Varian A-60 N.M.R. spectrometer.

Acknowledgement

The authors are grateful to the U.S. Advanced Research Projects Agency for financial support of this work through contract SD-88 with Harvard University.

REFERENCES

1. Rochow, E.G., J. Am. Chem. Soc. 69, 1729-31 (1947).
2. Rochow, E.G., Didtschenko, R., and West, R.C., Jr., J. Am. Chem. Soc. 73, 5486-7 (1951).
3. Flood, E.A., J. Am. Chem. Soc. 54, 1663 (1932).
4. Lesbre, M., Mazerolles, P., and Manuel, G., Compt. Rend. 257, 2303-6 (1963).
5. Dab, M., Organometallic Compounds, Springer-Verlag, N.Y., 1967 Vol. II, pp. 83-87.
6. Kerk, G.J.M. van der, Rijkens, F., and Janssen, M.J., Rec. Trav. Chem. 81, 764-74 (1962).
7. Rijkens, F., and van der Kerk, G.J.M., Rec. Trav. Chim. 83, 723-32 (1964).
8. Lesbre, M., and Saige J., Compt. Rend. 252, 1976-8 (1961).
9. Riemschneider, R., Menge, K., and Klang, P., Z. Naturforsch. 11b, 115-16 (1956).
10. Organic Insertion Reactions of Group IV Elements, by E.Y. Lukevits and M.G. Voronkov, Consultants Bureau, N.Y., 1966; Mironov, V.F. et al., Izv. Akad. Nauk SSSR, Khim. Nauki 1962, 460-5.
11. Mironov, V.F., Gar, T.K., and Leiters, L.A., Izv. Akad. Nauk SSSR, Khim. Nauki 1962, 1387-92.
12. Seyferth, D., J. Org. Chem. 22, 1252-3 (1957).
13. Anderson, H.H., J. Am. Chem. Soc. 82, 3016-18 (1960).
14. Mironov, V.F., Dzhurinskaya, N.G., and Petrov, A.D., Izv. Akad. Nauk SSSR, Khim. Nauki 1962, 460-5.
15. Smith, F.J., and Jones, E., A Scheme of Qualitative Organic Analysis, Blackie & Son Ltd., London, 1949, pp. 89-90.
16. Bellamy, L.J., The Infra-red Spectra of Complex Molecules, Methuen & Co. Ltd., 1964, p. 34.
17. Winkler, C., J. Prakt. Chem. 142 (N.S. 34), 222 (1886).
18. Winkler, C., J. Prakt. Chem. 144 (N.S. 36), 188 (1887).
19. Dennis, L.M., Orndorff, W.R., and Tabern, D.L., J. Am. Chem. Soc. 30, 1049-54 (1926).
20. Laubengayer, A.W., and Tabern, D.L., J. Phys. Chem. 30, 1047-8 (1926).

DOCUMENT CONTROL - ATA - R & D

(Security classification of title, body of abstract and indexing annotation must be entered when the overall report is classified)

1. ORIGINATING ACTIVITY (Corporate author) Mallinckrodt Laboratory, Dept. of Chemistry Harvard University Cambridge, Massachusetts		2a. REPORT SECURITY CLASSIFICATION Unclassified	
		2b. GROUP	
3. REPORT TITLE THE DIRECT SYNTHESIS OF ORGANOGermanium TRIHALIDES			
4. DESCRIPTIVE NOTES (Type of report and, inclusive dates) Interim technical report			
5. AUTHOR(S) (First name, middle initial, last name) E. Vassiliou and E. G. Rochow			
6. REPORT DATE September 1967		7a. TOTAL NO. OF PAGES 28	7b. NO. OF REFS 20
8a. CONTRACT OR GRANT NO. ARPA SD-88		9a. ORIGINATOR'S REPORT NUMBER(S) Technical Report No. ARPA 32	
b. PROJECT NO		9b. OTHER REPORT NO(S) (Any other numbers that may be assigned this report)	
c.			
d.			
10. DISTRIBUTION STATEMENT Reproduction in whole or in part is permitted by the U. S. Government. Distribution of this document is unlimited.			
11. SUPPLEMENTARY NOTES		12. SPONSORING MILITARY ACTIVITY	
13. ABSTRACT n-alkyl chlorides above propyl chloride react with germanium in the presence of copper as catalyst at 375-425°C to yield n- and i-alkylgermanium trihalides. The by-products of this reaction are the corresponding n- and i-alkenes. Chlorocyclohexane shows a rather poor yield. Phenyl germanium trichloride can be prepared by the action of germanium tetrachloride and phenyl chloride on germanium under similar conditions.			

14

KEY WORDS

LINK A

LINK B

LINK C

ROLE

WT

ROLE

WT

ROLE

WT

Organogermanium trihalides
n-alkenes
i-alkenes
Direct synthesis