

AD657990

REPORT NUMBER 159

JUNE 1965

FINAL DESIGN WEIGHT REPORT



LIFT FAN FLIGHT RESEARCH AIRCRAFT PROGRAM

CONTRACT NUMBER DA44-177-TC-715

GENERAL  ELECTRIC

Reproduced by the
CLEARINGHOUSE
for Federal Scientific & Technical
Information Springfield Va. 22151

Report Number 159

Final Design Weight Report

XV-5A Lift Fan
Flight Research Aircraft Program
Contract DA 44-177-TC-715

June 1965

ADVANCED ENGINE AND TECHNOLOGY DEPARTMENT
GENERAL ELECTRIC COMPANY
CINCINNATI, OHIO 45215

This document has been approved
for public release and sale; its
distribution is unlimited.

DDC
RECEIVED
SEP 15 1967
B

18 JUN 1965

TABLE OF CONTENTS

		<u>PAGE</u>
1.0	INTRODUCTION	1
2.0	WEIGHT AND BALANCE	3
2.1	WEIGHT AND CENTER OF GRAVITY SUMMARY	5
2.2	GROUP WEIGHT STATEMENT	7
2.3	DETAIL WEIGHT STATEMENT	19
2.4	ACTUAL WEIGHT AND CENTER OF GRAVITY	93
2.5	WEIGHT EMPTY - WEIGHT AND BALANCE SUMMARY	99
2.6	WEIGHT EMPTY - WEIGHT AND BALANCE DETAILS	103
2.7	INSTRUMENTATION	125
2.8	MOMENT CHANGE - LANDING GEAR EXTENDED	129
2.9	FUEL CENTER OF GRAVITY GRAPHS	135
2.10	GROSS WEIGHT BALANCE CALCULATIONS	141
2.11	GROSS WEIGHT CENTER OF GRAVITY GRAPH	149
2.12	DETERMINATION OF UNUSABLE FUEL	153
3.0	SUPPLEMENTARY DATA	157
4.0	MOMENT OF INERTIA	169
4.1	GROSS WEIGHT MOMENT OF INERTIA	169
4.2	FUSELAGE MOMENT OF INERTIA	173
4.3	WING MOMENT OF INERTIA	179
4.4	HORIZONTAL TAIL MOMENT OF INERTIA	189
4.5	VERTICAL TAIL MOMENT OF INERTIA	195
4.6	INSTRUMENTATION MOMENT OF INERTIA	199

1.0 INTRODUCTION

This is the actual weights report for the U.S. Army XV-5A Lift Fan Flight Research Aircraft. The report is submitted as supplementary information for Contract No. DA44-177-TC-715 and is representative of both aircraft Serial Numbers 62-4505 and 62-4506.

The XV-5A was designed to evaluate the flight characteristics of the lift fan propulsion system and to demonstrate capability of the system with a high subsonic aircraft. The aircraft has an aspect ratio 3.4 mid-wing and provides side-by-side seating for pilot and observer. The total propulsion system consists of the General Electric X353-5B propulsion unit made up of two J-85-5 turbojet engines, two wing fans, and two exhaust gas flow diverter valves. The General Electric X376 pitch fan is installed at the nose of the aircraft. The general arrangement and three-view of the aircraft are shown in Figures 1 and 2.

The report contains weight and balance data in summary and in detail. The summary data is given for several fuel and flight test instrumentation combinations considered compatible with the Flight Test Program. Performance requirements were written for endurance missions of 20 to 45 minutes and therefore weights data are given for the aircraft with fuel to perform these missions with flight test instrumentation included. The design gross weight of the aircraft is 9200 lbs., and therefore data is given for this weight.

The Weight Empty given herein includes only those items required by Aircraft Specification. It does not, for instance, include the auxiliary fuel tank nor instrumentation or other temporary items installed for initial flight test purposes only.

Horizontal distances used in this report are measured from fuselage station zero. Vertical distances are measured from a theoretical plane 100 inches below the fuselage horizontal reference plane.

XV-5A GENERAL ARRANGEMENT

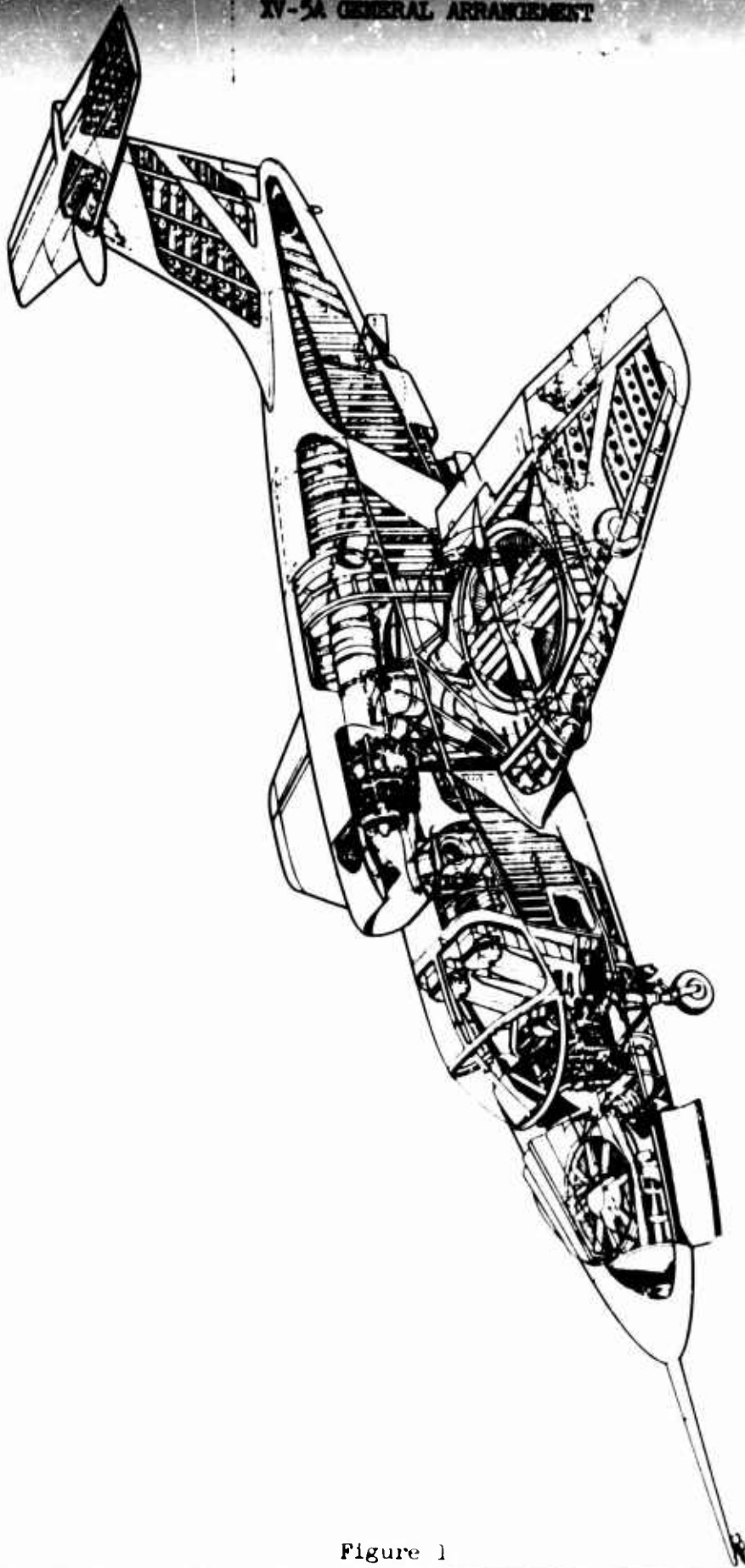
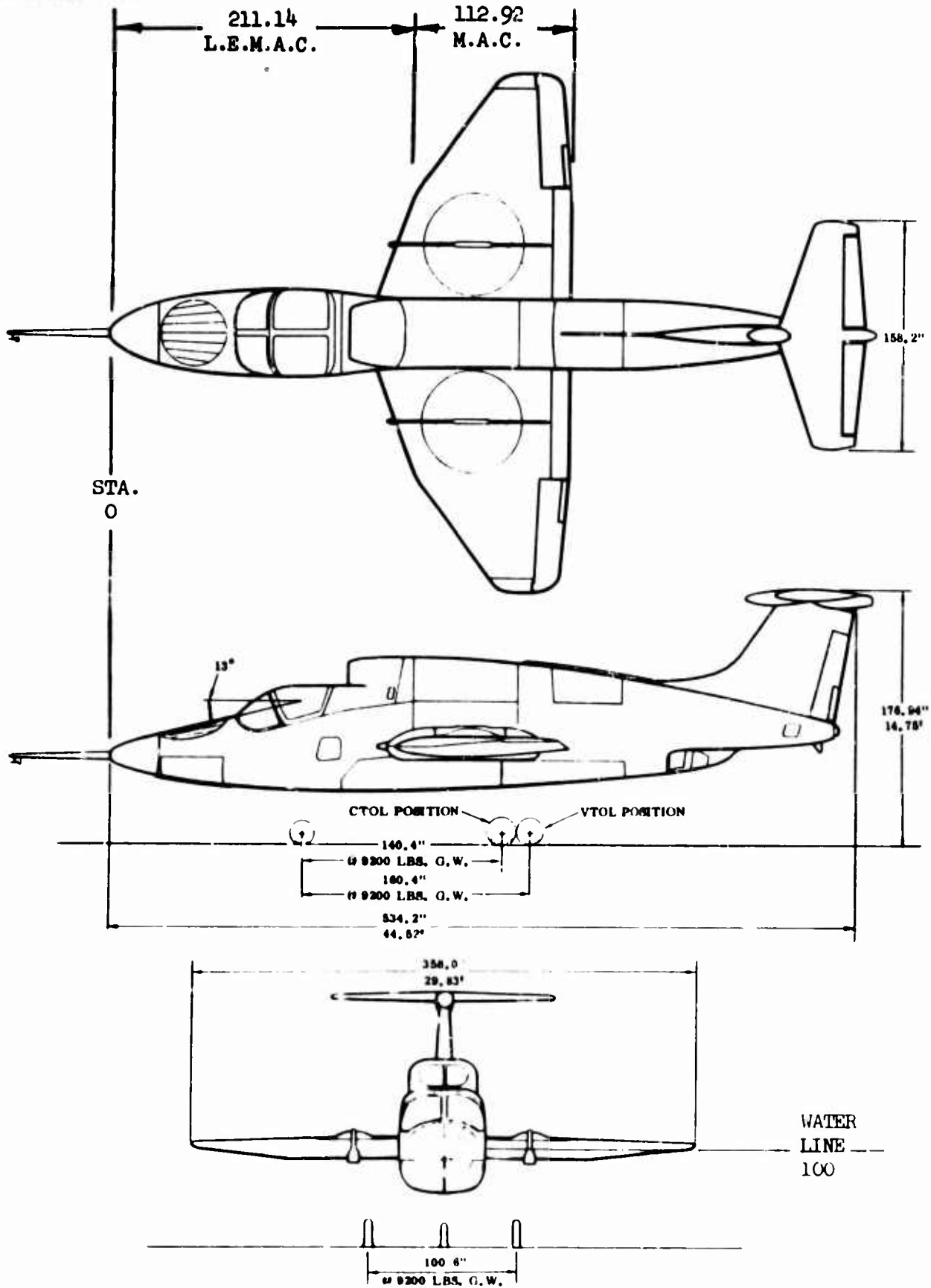

Figure 1

2.0 WEIGHT AND BALANCE

2.1 Weight and Center of Gravity Summary

XV-5A THREE VIEW



Figure

SUMMARY - WEIGHT AND CENTER OF GRAVITY

CONFIGURATION	WEIGHT	HORIZONTAL		VERTICAL		% MAC
		ARM	MOMENT	ARM	MOMENT	
WEIGHT EMPTY - Gear Up	8063	248.4	2002587	113	911119	33.0
*GROSS WEIGHT CONDITIONS						
20 Minute Mission	9972	240.7	2397591	111	1113255	26.2
45 Minute Mission	10873	241.6	2624332	112	1223417	27.0
Design Gross Weight - 9200 Lbs.	9200	240.8	2213102	111	1030401	26.3
Design Gross Weight - 9200 Lbs. (Less Instrumentation)	9200	245.0	2251346	111	1032896	30.0
Full Fuel - Incl. Aux. Tank	12095	244.2	2951725	113	1383611	29.3
Extended Range (Less Instrumentation)	12500	246.0	3073429	111	1403248	30.9

*Note: All conditions include 515 lbs. of standard instrumentation equipment unless otherwise noted.

All conditions are with the landing gear retracted.

Forward Center of Gravity Limit - Sta. 240, 25.56% MAC

Aft Center of Gravity Limit - Sta. 246, 30.87% MAC

2.2 Group Weight Statement

U.S. ARMY
XV-5A

LIFT-FAN FLIGHT RESEARCH AIRCRAFT

GROUP WEIGHT STATEMENT

- ACTUAL
- CROSS OUT THOSE NOT APPLICABLE -

CONTRACT DA44-177-TC-715

AIRPLANE-GOVERNMENT NUMBER 62-4505 and 62-4506

AIRPLANE-CONTRACTOR NUMBER

MANUFACTURED BY RYAN AERONAUTICAL COMPANY

ENGINE

MAIN

AUXILIARY

MANUFACTURED BY

GENERAL ELECTRIC

GENERAL ELECTRIC

MODEL

J85-GE-5B

X353-5B

NUMBER

2

2

PROPELLER

MAIN

AUXILIARY

MANUFACTURED BY

MODEL

NUMBER

AN 9103-D-TAI
NAME
DATE

GROUP WEIGHT STATEMENT
WEIGHT EMPTY

PAGE 11
MODEL XV-5A
REPORT 64B148

1	WING GROUP					1059.27
2	CENTER SECTION-BASIC STRUCTURE					423.12
3	INTERMEDIATE PANEL-BASIC STRUCTURE					
4	OUTER PANEL-BASIC STRUCTURE - INCL TIPS	4.12	LBS			144.08
5						
6	SECONDARY STRUCTURE - INCL WING FOLD MECH		LBS			353.84
7	AILERONS - INCL BALANCE WEIGHT		LBS			51.69
8	FLAPS-TRAILING EDGE					75.54
9	-LEADING EDGE					
10	SLATS					
11	SPOILERS					
12	SPEEDBRAKES					
13						
14						
15	TAIL GROUP					267.07
16	STABILIZER-BASIC STRUCTURE					103.76
17	FINS-BASIC STRUCTURE-INCL DORSAL	3.15	LBS			81.91
18	SECONDARY STRUCTURE-STABILIZER & INS (5.00 Vert. & 3.87 Horiz.)					8.87
19	ELEVATOR - INCL BALANCE WEIGHT	17.56	LBS			40.10
20	RUDDERS - INCL BALANCE WEIGHT	12.21	LBS			32.43
21						
22						
23	BODY GROUP					1340.69
24	FUSELAGE OR HULL-BASIC STRUCTURE					798.91
25	BOOMS-BASIC STRUCTURE					
26	SECONDARY STRUCTURE-FUSELAGE OR HULL					157.65
27	-BOOMS					
28	-SPEEDBRAKES					
29	-DOORS, PANELS & MISC					384.13
30						
31	LIGHTING GEAR GROUP-LAND - TYPE					481.85
32	LOCATION		*ROLLING	STRUCT	CONTROLS	
33			ASSEMBLY			
34	MAIN	80.98	258.23	60.35		399.56
35	NOSE	20.17	55.31	6.81		82.29
36						
37						
38						
39	LIGHTING GEAR GROUP-WATER					
40	LOCATION		FLOATS	STRUTS	CONTROLS	
41						
42						
43						
44						
45	SURFACE CONTROLS GROUP					440.20
46	COCKPIT CONTROLS					24.45
47	AUTOMATIC STABILIZATION SYSTEM					40.72
48	SYSTEM CONTROLS - INCL POWER & FEEL CONT				LBS	137.15
49	VERTICAL TAKE-OFF CONTROLS					237.88
50	ENGINE SECTION OR NACELLE GROUP					44.55
51	INBOARD					
52	CENTER					44.55
53	OUTBOARD					
54	DOORS, PANELS & MISC					
55						
56	PAGE TOTAL					3633.63
57						

* WHEELS, BRAKES, TIRES, TUBES AND AIR

AN 9103-D-TAB
NAME
DATE

GROUP WEIGHT STATEMENT
WEIGHT EMPTY

PAGE 13
MODEL
REPORT 64B148

	LIFT	PITCH		
1 PROPULSION GROUP				3676.34
2	X FAN	FAN XX	MAIN	
3 ENGINE INSTALLATION	1773.80	116.42		935.90
4 AFTERBURNERS-IF FURN SEPARATELY				
5 ACCESSORY GEAR BOXES & DRIVES				28.24
6 SUPERCHARGER FOR TURBO TYPES				
7 AIR INDUCTION SYSTEM	131.94	136.39		63.01
8 EXHAUST SYSTEM		84.37		220.47
9 COOLING SYSTEM				10.30
10 LUBRICATING SYSTEM				
11 TANKS				
12 COOLING INSTALLATION				
13 DUCTS, PLUMBING, ETC				
14 FUEL SYSTEM				
15 TANKS-PROTECTED				
16 -UNPROTECTED				53.42
17 PLUMBING, ETC				70.97
18 WATER INJECTION SYSTEM				
19 ENGINE CONTROLS				42.90
20 STARTING SYSTEM				8.21
21 PROPELLER INSTALLATION				
22				
23 SUB TOTAL-PROPULSION	1905.74	337.18		1433.42
24 AUXILIARY POWER PLANT GROUP				
25 INSTRUMENTS & NAVIGATIONAL EQUIPMENT GROUP				73.08
26 HYDRAULIC & PNEUMATIC GROUP				115.43
27				
28				
29 ELECTRICAL GROUP				195.57
30 AC SYSTEM				5.82
31 DC SYSTEM				189.75
32 ELECTRONICS GROUP				39.64
33 EQUIPMENT				38.02
34 INSTALLATION				1.62
35				
36 ARMAMENT GROUP - INCL GUNFIRE PROTECTION			LOS	
37 FURNISHINGS & EQUIPMENT GROUP				212.95
38 ACCOMMODATIONS FOR PERSONNEL				166.52
39 MISCELLANEOUS EQUIPMENT				12.06
40 FURNISHINGS				
41 EMERGENCY EQUIPMENT				34.37
42				
43 AIR CONDITIONING & ANTI-ICING EQUIPMENT GROUP				34.27
44 AIR CONDITIONING				33.15
45 ANTI-ICING				1.12
46				
47 PHOTOGRAPHIC GROUP				
48 AUXILIARY GEAR GROUP				27.39
49 HANDLING GEAR				.66
50 ARRESTING GEAR				26.73
51 CATAPULTING GEAR				
52 ATO GEAR				
53				
54 MANUFACTURING VARIATION				
55 UNACCOUNTABLE				64.70
56 PAGE TOTAL				
57 TOTAL-WEIGHT EMPTY - PG 2-3				8063.00

AN 9103-D-TAB
 NAME
 DATE

GROUP WEIGHT STATEMENT
 USEFUL LOAD & GROSS WEIGHT

PAGE 15
 MODEL XV-5A
 REPORT 64B148

LOAD CONDITION		20 MIN. MISSION	45 MIN. MISSION	FULL FUEL	EXTENDED RANGE
2					
3	SCREW - NO. (1)	200	200	200	200
4	PASSENGERS - NO.				
5	FUEL				
6	CRUISEABLE	26	26	36	49
7	INTERNAL	1132	2033	2430	2430
8	INTERNAL - AUXILIARY			780	780
9	INTERNAL - EXT. RANGE				787
10	EXTERNAL				
11					
12	BOMB BAY				
13					
14	BOYL				
15	TRAPPED	3	3	3	3
16	ENGINE	12	12	12	12
17					
18	FUEL TANKS-LOCATION				
19	WATER INJECT. FLUID			35	155
20					
21	BAGGAGE				
22	CARGO				
23					
24	ARMAMENT				
25	GUNS-LOCATION FIX/FLEX QUANTITY CALIBER				
26					
27					
28					
29					
30					
31					
32	AMMUNITION				
33					
34					
35					
36					
37					
38					
39	INSTALLATIONS-BOMB, TORPEDO, ROCKET, ETC				
40	BOMB OR TORPEDO RACKS				
41					
42	AUXILIARY OXYGEN	19	19	19	19
43	EMERGENCY ESCAPE AXE	2	2	2	2
44					
45					
46	EQUIPMENT				
47	PYROTECHNICS				
48	PHOTOGRAPHIC				
49					
50	OXYGEN				
51					
52	MISCELLANEOUS				
53	INSTRUMENTATION	515	515	515	
54					
55	USEFUL LOAD	1909	2810	4032	4437
56	WEIGHT EMPTY	8063	8063	8063	8063
57	GROSS WEIGHTS - PG 2-4	9972	10873	12095	12500

*IF NOT SPECIFIED AS WEIGHT EMPTY

AN 9103-D-TAB
NAME
DATE

GROUP WEIGHT STATEMENT
DIMENSIONAL & STRUCTURAL DATA

PAGE 17
MODEL
REPORT 64B148

1	LENGTH-OVERALL-FT	50.48 (Incl. Nose Boom)			HEIGHT-OVERALL STATIC-FT	14.75	
2		MAIN	AUX	BOOMS	FUS	X	NACELLES
3		FLOATS	FLOATS		OR HULL	INBOARD	CENTER OUTBOARD
4	LENGTH-MAX-FT				42.92		
5	DEPTH-MAX-FT				7.66		
6	WIDTH-MAX-FT				5.00		
7	WETTED AREA-SQ FT (1216 TOTAL AIRPLANE)				627.00		
8	*FLOAT/HULL DISPL MAX LBS						
9	FUSELAGE VOLUME-CU FT	PRESSURIZED	NONE		TOTAL	735.0	
10					WING	H TAIL	V TAIL
11	GROSS AREA-SQ FT (HORIZ.STAB.=40.86, VERT.STAB.=44.60)				260.32	52.86	51.00
12	WEIGHT/GROSS AREA-#/SQ FT				4.07	2.37	1.94
13	SPAN-FT				29.83	13.18	7.75 Approx.
14	ELEVATORS					12.00	
15	RUDDER						6.40
16	SWEEPBACK-AT 25% CHORD LINE-DEGREES				15.0&28.3	13.70	30.00
17	-AT % CHORD LINE-DEGREES						
18	**THEORETICAL ROOT CHORD -LENGTH-INCHES				145.00	65.64	103.92
19	-MAX THICKNESS-INCHES				15.30	7.88	17.15
20	***CHORD AT PLANFORM BREAK-LENGTH-INCHES				109.00		
21	-MAX THICKNESS-INCHES				14.38		
22	***THEORETICAL TIP CHORD -LENGTH-INCHES				43.00	30.60	54.00
23	-MAX THICKNESS-INCHES				5.16	3.67	7.02
24	DORSAL AREA, INCL IN FUS - HULL - V TAIL-AREA-SQ FT						2.40
25	TAIL LENGTH-25% M.A.C. WING TO 25% M.A.C. H TAIL-FT				22.30		
26	AREA-SQ FT/AIRPLANE FLAPS L.E. T.E.				25.37		
27	LATERAL CONTROLS SLATS				SPOILERS	AILERONS	20.11
28	SPEED BRAKES WING				FUE/HULL		
29							
30							
31	LIGHTING GEAR			LOCATION		MAIN	NOSE
32	LENGTH-OLEO EXT-C.L. AXLE TO C.L. TRUNNION-INCHES					65.00	38.35
33	OLEO TRAVEL-FULL EXT TO COLLAPSED-INCHES					9.20	8.0
34	FLOAT OR SKI STRUT LENGTH-INCHES						
35	ARRESTING HOOK LENGTH-C.L. HOOK TRUNNION TO C.L. HOOK POINT-INCHES						
36	HYDRAULIC SYSTEM CAPACITY-GALS			4.5			
37	FUEL & LUB SYST		NUMBER	***GALS		NUMBER	***GALS
38		LOCATION	TANKS	PROTECTED		TANKS	UNPROTECTED
39	FUEL-INTERNAL	WING					
40		FUS/HULL				494	
41	-EXTERNAL						
42	-BOMB BAY						
43							
44	OIL						
45							
46	STRUCTURAL DATA-CONDITION			WING		STRESS	ULT L.P.
47				FUEL-LBS		GROSS WT	
48	FLIGHT					9200	6.0
49	LANDING					9200	6.0
50	MAX GROSS WT WITH ZERO WING FUEL					9200	6.0
51	CATAPULTING						
52	MINIMUM FLYING WEIGHT					7693	6.0
53	LIMIT AIRPLANE LANDING SINKING SPEED-FT/SEC					9200	10.0
54	WING LIFT ASSUMED FOR LANDING DESIGN CONDITION-GW						
55	STALL SPEED-LANDING CONFIGURATION-POWER OFF-KNOTS						
56	PRESSURIZED CABIN-ULT DESIGN PRESSURE DIFFERENTIAL-FLIGHT P.S.I.						NONE
57	AIRFRAME WEIGHT-AS DEFINED IN AN-W-11 -LBS						

* LBS OF SEA WATER @ 64 LBS/CU FT
**PARALLEL TO & AT CENTERLINE AIRPL

*** PARALLEL TO CENTERLINE AIRPL
****TOTAL USABLE CAPACITY

RYAN

REPORT NO. 64B148	WEIGHT AND BALANCE REPORT XV-5A	PAGE 19
----------------------	------------------------------------	---------

2.3 Detail Weight Statement

AN 9102-D-TAB
NAME
DATE

PAGE 21
MODEL
REPORT 64B148

U.S. ARMY
XV-5A

LIFT-FAN FLIGHT RESEARCH AIRCRAFT

DETAIL WEIGHT STATEMENT

- ACTUAL

-CROSS OUT THOSE NOT APPLICABLE-

CONTRACT DA44-177-TC-715

AIRPLANE-GOVERNMENT NUMBER 62-4505 & 62-4506

AIRPLANE-CONTRACTOR NUMBER

MANUFACTURED BY RYAN AERONAUTICAL COMPANY

ENGINE

MAIN

LIFT-FAN

MANUFACTURED BY

GENERAL ELECTRIC

GENERAL ELECTRIC

MODEL

J85-GE-5B

X353-5B

NUMBER

2

2

PROPELLER

MAIN

AUXILIARY

MANUFACTURED BY

MODEL

NUMBER

AN 9102-D-TAB
NAME
DATE

WING GROUP
BASIC STRUCTURE

PAGE 23
MODEL
REPORT 64B148

				CENTER SECTION	INTERM PANEL	OUTER PANEL
1						
2						
3						
4	UPPER-FRONT SPAR CAP					
5	-INTERMEDIATE SPAR CAP					
6	-REAR SPAR CAP					
7	-AUXILIARY SPAR CAP					
8	-INTERSPAR COVER			17.29		56.04
9	-SPANWISE STIFFENERS					
10	-JOINTS, SPLICES & FAST.			8.81		
11	-BRACKETS-SKIN-SUPPORTED			5.18		
12						
13						
14	LOWER-FRONT SPAR CAP					
15	-INTERMEDIATE SPAR CAP					
16	-REAR SPAR CAP					
17	-AUXILIARY SPAR CAP					
18	-INTERSPAR COVER			25.07		
19	-SPANWISE STIFFENERS					
20	-JOINTS, SPLICES & FAST.			4.44		
21	BRACKETS-SKIN SUPPORTING			6.90		
22	FRONT SPAR			94.34		14.79
23	REAR SPAR			88.50		13.55
24	SPAR WEB & STIFF.-FRONT					
25	-INTERMEDIATE					
26	-REAR					
27	-AUXILIARY					
28	-JOINTS, SPLICES & FAST.					
29	DOUBLERS-SKIN					3.90
30						
31	INTERSPAR-RIBS			4.42		29.82
32	-BULKHEADS			23.09		
33	-CHORDWISE STIFFENERS					
34	-JOINTS, SPLICES & FAST.			5.83		1.77
35	FAN RING			25.95		
36	LEADING EDGE-COVER			36.00		10.80
37	-STIFFENERS					
38	-RIBS			22.09		3.48
39	-AUXILIARY SPARS					
40	-JOINTS, SPLICES & FAST.			5.28		1.20
41						
42						
43	TRAILING EDGE-COVER			16.95		3.48
44	-STIFFENERS					
45	-RIBS			3.75		1.27
46	-AUXILIARY SPARS			1.58		
47	-JOINTS, SPLICES & FAST.			1.32		.21
48	-STRIPS					.72
49						
50	TIPS					4.11
51	.					
52	FIREWALL-STRUCTURAL					
53	ATTACH FTGS.-WING TO FUS.			26.33		
54						
55	COLUMN TOTALS			423.12		144.00
56	TOTAL-BASIC STRUCTURE					267.00
57						

AN 9102-D-TAB
 NAME
 DATE

WING GROUP
 SECONDARY STRUCTURE
 DOORS, PANELS AND MISCELLANEOUS

PAGE 25
 MODEL
 REPORT 61-148

1	** *	X	XX	OPERATING MECHANISM				X
2	LO P AREA	STRUCT	MECH &	POWER	ACTUATOR	LOCK	EMERG	
3	SQ FT		CONTROLS	TRANS		MECH		
4								
5	SWING FOLD							
6								
7								
8	DOORS & FRAMES							
9	-LANDING							
10								
11	-BOMB							
12								
13								
14	-GUN							
15								
16	-AMMUNITION							
17								
18	-ROCKET							
19								
20	-LIFE RAFT							
21								
22	-ESCAPE							
23								
24	-ACCESS	15.88						
25								
26	-FAN C.S.-H-56.5	126.56	27.16	17.47	68.41	19.97		
27								
28	PANELS-NON STRUCTURAL							
29								
30	SEAL - FAN	16.30						
31								
32	SEAL - TE TO FLAP	1.64						
33								
34	INSULATION - EXTERNAL	29.59						
35								
36								
37								
38								
39								
40								
41								
42								
43								
44								
45								
46								
47								
48								
49	WALKWAYS, STEPS & GRIPS							
50								
51	FAIRING AND FILLEYS	30.86						
52								
53	EXTERIOR FINISH							
54								
55	COLUMN TOTALS	220.83	27.16	17.47	68.41	19.97		
56	TOTAL-SECONDARY STRUCTURE						353.84	
57								

* TYPE OF POWER- H-HYD, E-ELEC, P-PNEU, POWER TRANSMISSION FROM MAIN DISTRIBUTION POINT TO ACTUATING UNIT
 ** INDICATE LOCATION OF MAJOR DOORS- CS, OP, IP, ETC

AN 9102-D-TAB
NAME
DATE

WING GROUP
CONTROL SURFACES

PAGE 27
MODEL
REPORT 64B148

	X	AILERONS	XX	T.O.E. FLAPS	XX	L.O.E. FLAPS	X
		INBOARD	OUTBOARD	INBOARD	OUTBOARD	INBOARD	OUTBOARD
1							
2							
3							
4							
5	SPARS		5.60		8.95		
6							
7	STRINGERS				1.48		
8							
9	RIBS		8.81		14.00		
10							
11							
12	COVER AND STIFFENERS		9.77		34.35		
13							
14							
15	T.O.E. STRIPS		.42		1.80		
16							
17	FABRIC AND DOPE						
18							
19	TIPS		1.80				
20							
21	TABS - STRUCTURE		8.11				
22	TABS - BALANCE WEIGHTS		5.00				
23							
24							
25	TORQUE TUBES						
26							
27							
28							
29	BALANCE WEIGHTS & SUPPORTS						
30							
31	AERODYNAMIC SEALS		1.66				
32							
33							
34	CONTROL HORNS						
35	ACTUATOR ATTACH STRUCT.				2.48		
36							
37	ACCESS DOORS-NON STRUCT		.69				
38							
39	HINGES AND PINS		1.38		7.23		
40	EXTERIOR FINISH						
41	TOTALS-SURFACE						
42							
43	CONTROL SURFACE SUPPORTS						
44	HINGES		14.12		4.85		
45	BRACKETS		4.33		1.40		
46	TRACKS						
47	CARRIAGES						
48							
49							
50							
51							
52							
53							
54	TOTALS-SUPPORTS						
55	COLUMN TOTALS		61.69		76.54		
56	PAGE TOTAL						138.23
57	TOTAL WING GROUP						1059.27

AN 9102-D-TAB
 NAME
 DATE

TAIL GROUP
 BASIC STRUCTURE

PAGE 29
 MODEL
 REPORT 648148

	X STABILIZER XX		FINS		DORSAL
	CENTER	OUTER	CENTER	OUTER	
1					
2					
3					
4	UPPER-FRONT SPAR CAP				
5	-INTERMEDIATE SPAR CAP				
6	-REAR SPAR CAP				
7	-AUXILIARY SPAR CAP				
8	20.64		25.76		1.54
9	-INTERSPAR COVER				
10	-SPANWISE STIFFENERS				
11	-JOINTS, SPLICES & FAST.				
12	FRAMES				
13					.88
14	LOWER-FRONT SPAR CAP				
15	-INTERMEDIATE SPAR CAP				
16	-REAR SPAR CAP				
17	-AUXILIARY SPAR CAP				
18	-INTERSPAR COVER				
19	-SPANWISE STIFFENERS				
20	-JOINTS, SPLICES & FAST.				
21	2.73		4.65		
22	8.43		10.23		
23	3.44		3.01		
24	SPAR WEB & STIFF.-FRONT				
25	-INTERMEDIATE				
26	-REAR				
27	-AUXILIARY				
28	-JOINTS, SPLICES & FAST.				
29					
30					
31	15.10		20.71		
32	-BULKHEADS				
33	-CHORDWISE STIFFENERS				
34	2.15				
35	-JOINTS, SPLICES & FAST.				
36	6.24		4.67		
37	-STIFFENERS				
38	2.48		2.99		
39	-RIBS				
40	-AUXILIARY SPARS				
41	-JOINTS, SPLICES & FAST.				
42					
43	TRAILING EDGE-COVER				
44	.05		.68		
45	.66		.28		
46	-STIFFENERS				
47	-RIBS				
48	-AUXILIARY SPARS				
49	-JOINTS, SPLICES & FAST.				
50	35.90		2.77		
51	4.26				
52	.29		.42		
53	1.39		2.59		
54	FAIRING				
55	TIPS				
56	ACTUATOR FITTING				
57	MISCELLANEOUS				
58	PIVOT FITTING				
59	EXTERIOR FINISH				
60	103.76		78.76		.10
61	COLUMN TOTALS				
62	TOTAL-BASIC STRUCTURE				
63					3.15
64					185.67
65					

AN 9102-D-TAB
 NAME
 DATE

TAIL GROUP
 SECONDARY STRUCTURE
 DOORS, PANELS AND MISCELLANEOUS

PAGE 31
 MODEL
 REPORT 64B148

1	** *	X	XX	OPERATING MECHANISM				X
2	LO P AREA	STRUCT	MECH &	POWER	ACTUATOR	LOCK	EMERG	
3	SQ FT		CONTROLS	TRANS		MECH		
4								
5	DOORS & FRAMES							
6	-LANDING							
7								
8								
9								
10	-ACCESS							
11	-VERTICAL	2.60						
12								
13								
14								
15								
16								
17								
18								
19								
20								
21								
22								
23								
24								
25								
26								
27								
28	PANELS-NON STRUCTURAL							
29								
30								
31								
32	AERO SEAL ATTACH - HORIZ.	.91						
33	AERO SEAL ATTACH - VERT.	.41						
34								
35								
36								
37								
38								
39								
40								
41								
42								
43								
44								
45								
46								
47								
48								
49	WALKWAYS, STEPS & GRIPS							
50	FAIRING AND FILLETS							
51								
52								
53	EXTERIOR FINISH - HORIZ.	2.96						
54	" " - VERT.	1.99						
55	COLUMN TOTALS	8.87						
56	TOTAL-SECONDARY STRUCTURE							8.87
57								

* TYPE OF POWER- H-HYD, E-ELEC, P-PNEU, POWER TRANSMISSION FROM MAIN DISTRIBUTION POINT TO ACTUATING UNIT
 ** INDICATE LOCATION OF MAJOR DOORS- CS, OP, IP, ETC

AM 9102-D-TAG
NAME
DATE

TAIL GROUP
CONTROL SURFACES

PAGE 33
MODEL REPORT 64B148

	X	XX	RUDDERS		
			ELEVATION	CENTER	OUTER
1					
2					
3					
4 SPARS			2.14	4.55	
5					
6					
7					
8 RIBS			2.44	1.85	
9 RIB ATTACH ANGLES				.11	
10					
11					
12 COVER AND STIFFENERS			8.70	4.02	
13					
14					
15 STRENGTH STRIPS			.60	.24	
16					
17 FABRIC AND DOPE					
18					
19					
20					
21 TABS				1.88	
22					
23					
24					
25 TORQUE TUBES			3.15	3.48	
26					
27					
28					
29 BALANCE WEIGHTS & SUPPORTS			17.56	12.21	
30					
31 AERODYNAMIC SEALS			1.23	.84	
32					
33					
34 CONTROL HORNS					
35					
36					
37 ACCESS DOORS-NON STRUCT			.38	.53	
38					
39 HINGES AND PINS			1.78	.96	
40 EXTERIOR FINISH					
41					
42 TOTALS-SURFACE					
43					
44 CONTROL SURFACE SUPPORTS					
45 HINGES			2.12	.69	
46 BRACKETS				.77	
47				.32	
48					
49					
50					
51					
52					
53					
54 TOTALS-SUPPORTS					
55 COLUMN TOTALS			40.10	32.43	
56 PAGE TOTAL					72.53
57 TOTAL-TAIL GROUP - PG 6-8					267.07

AN 9102-D-TAB
NAME
DATE

BODY GROUP
BASIC STRUCTURE

PAGE 35
MODEL
REPORT 64B148

1	X	FUSELAGE OR HULL	XX BOOMS
2			
3		STATION	
4		*BULKHEADS & FRAMES	
5		FRONT HINGE FRAME	3.92
6		REAR HINGE FRAME	12.40
7			
8		FRAME - STA. 91	12.49
9		BULKHEAD - STA. 214	47.13
10		CANTED BULKHEAD - STA. 146	27.76
11		BULKHEAD - STA. 165.2	14.46
12		FRAME - ENGINE SUPT. 214	13.63
13		BULKHEAD - M.L.G. DRAG STRUT	20.25
14			
15		BULKHEAD - M.L.G. STA. 287	20.06
16		BULKHEAD - WING SPAR - 296	39.49
17			
18			
19			
20		BULKHEAD - STAB FRONT SPAR	5.12
21		- STAB CTR SPAR	6.30
22		- STAB REAR SPAR	3.44
23		TRUSS STRUCTURE	114.03
24		MINOR FRAMES	98.64
25		JOINTS, SPLICES, FASTENERS	19.51
26		OVERTURN STRUCTURE	
27		VERTICAL STIFFENERS	2.55
28		COVER-UPPER BETWEEN LONGN	25.33
29		-SIDE BETWEEN LONGERONS	50.31
30		-LOWER BETWEEN LONGERONS	21.43
31		HORIZONTAL STIFFENERS	4.51
32		COVER LONGL STIFF.-UPPER	
33		-SIDE	6.99
34		-LOWER	
35		WING L.E. ATTACH FTGS.	.78
36		DRAG ANGLE - FUS. TO FIN	4.99
37		LONGERONS-UPPER	36.55
38		LONGERONS-LOWER	40.43
39		LONGERON - UPPER EXTERNAL	8.04
40		HORIZ. SHEAR WEBS	65.05
41		LONGITUDINAL PARTITIONS	
42			
43		FLOORING AND SUPPORTS	21.21
44		NOSE WHEEL WELL	12.89
45		MAIN GEAR DOOR SUPPORT	21.18
46			
47		FIREWALL-STRUCTURAL	
48		PITCH FAN MOUNT STRUCTURE	15.63
49		KEELSONS	1.32
50		KEEL	
51		MISCELLANEOUS	1.09
52		CHINE AND SPRAY STRIPS	
53		STEP ASSEMBLY	
54		STAIRWAYS-STRUCTURAL	
55		COLUMN TOTALS	798.91
56		TOTAL-BASIC STRUCTURE	798.91
57			

* LIST ALL MAIN & WATERTIGHT BULKHEADS & FRAMES INDIVIDUALLY. MINOR FRAMES MAY BE COMBINED.

AN 9102-D-TAB
NAME
DATE

BODY GROUP
SECONDARY STRUCTURE

PAGE 37
MODEL
REPORT 64B148

	X	FUSELAGE OR HULL	XX	XX	X
1					
2				BOOMS	SPEED
3					BRAKES
4		ENCLOSURE-EXCL TURKEY ENC			
5		CANOPY	63.13		
6		CANOPY-OPERATING MECH			
7		-RAILS			
8*		-CYLINDERS & PLUMBING			
9		-FLUID			
10		-HINGE STRUCTURE	4.25		
11		-LATCH STRUCTURE	.78		
12					
13		GUNNER-TAIL			
14					
15		BOMBARDIER			
16		SIGHTING BLISTERS			
17					
18		WINDSHLD-EXCL BULLET PROT	53.94		
19					
20		WINDOWS, PORTS-INCL FRAMES			
21					
22		HEAT SHIELDING - INTERNAL	8.85		
23					
24					
25					
26					
27					
28		FLOORING AND SUPPORTS			
29					
30					
31		STAIRWAYS & LADDERS-FIXED			
32					
33		JACK PAD PROVISIONS	1.07		
34		STERNPOST AND FITTINGS			
35		NOSE BUMPER-HULL			
36		RUBBING STRIPS			
37					
38		NOSE CONE	14.85		
39					
40		TAIL CONE	9.16		
41		TAIL BUMPER	1.62		
42					
43		SPEED BRAKES-STRUCTURE			
44		-SUPPORTS			
45					
46					
47					
48					
49					
50					
51					
52					
53					
54					
55		COLUMN TOTALS	157.65		
56		PAGE TOTAL			157.65
57					

* FROM MAIN DISTRIBUTION POINT TO ACTUATING UNIT.

AN 9102-D-TAB
 NAME
 DATE

BODY GROUP
 SECONDARY STRUCTURE
 DOORS, PANELS AND MISCELLANEOUS

PAGE 39
 MODEL
 REPORT 64B148

1	** *	X	XX	OPERATING MECHANISM				
				LO P AREA	STRUCT	MECH & POWER	ACTUATOR	LOCK
2				MECH & POWER	ACTUATOR	LOCK	EMERG	
3				CONTROLS	TRANS	MECH		
4								
5	DOORS & FRAMES							
6	-LANDING - NOSE F-H-	5.66	7.31	4.00				
7	-LANDING - MAIN F-H-	28.1	66.40	5.89	3.71	35.85		
8								
9								
10	-BOMB							
11								
12								
13	-GUN							
14								
15	-AMMUNITION							
16								
17	-ROCKET							
18								
19	-LIFE RAFT							
20								
21	-ESCAPE							
22								
23								
24	-WATERTIGHT							
25								
26	-COMPARTMENT							
27								
28	-ENTRANCE							
29								
30								
31	-ACCESS		29.97					
32	-ACCESS - STA. 100 to 133		7.36					
33	-SPIN CHUTE		2.31					
34	ACCESS - ELECT.COMPT.		7.02					
35	-ENGINE							
36								
37	-CAMERA							
38								
39	PANELS-NON STRUCTURAL							
40	-ENGINE ACCESS		47.54					
41	-SIDE 114 to 287		36.30					
42	-LOWER 165 to 276		52.88					
43								
44	-M.L.G. WHEEL WELL		3.39					
45	-COVER MECH. MIXER		2.11					
46	-SEAL FUS. TO CANOE		2.65					
47	-CLOSURE - PLTCH FAN		2.81					
48								
49	WALKWAYS, STEPS & GRIPS							
50	FAIRING - TAILPIPE EXIT		19.88					
51	FAIRING AND FILLETS							
52	EXTERIOR FINISH		5.59					
53	EXHAUST DEFLECTOR PLATE		1.70					
54	INSULATION - EXTERNAL		28.40					
55	COLUMN TOTALS		354.68	9.89	3.71	35.85		
56	PAGE TOTAL						384.13	
57	TOTAL-BODY GROUP - PG 9-11							1340.69

- * TYPE OF POWER- H-HYD, E-ELEC, P-PNEU, POWER TRANSMISSION FROM MAIN DISTRIBUTION POINT TO ACTUATING UNIT
- ** INDICATE LOCATION OF MAJOR DOORS- B-BOOM, F-FUSELAGE, H-HULL.
- ∅ MECHANICAL LINKAGE TO GEAR

AN 9102-D-TAB
NAME
DATE

ALIGNING GEAR GROUP

PAGE 41
MODEL
REPORT 64B148

1TYPE	MAIN	NOSE			
2					
3					
4					
5					
6	QUANTITY				
6	WHEELS	28.90		9.22	
7	TIRES	23.70		10.95	
8	TUBES				
9	AIR				
10	BRAKES	28.38			
11					
12					
13	ANTI-SKID DEVICE				
14					
15	FLOATS-BULKHEADS				
16	-FRAMES				
17	-COVER				
18	-COVER STIFF.-LONG				
19	-KEELSONS				
20	-KEEL				
21	-LONGITUDINAL PARTITIONS				
22	-CHINE, SPRAY STRIP				
23	-STEP ASSEMBLY				
24	-POST ASSEMBLY				
25	-NOSE BUMPER				
26	INSPECTION DOORS				
27	WALKWAYS				
28	EXTERIOR FINISH				
29	SKIDS OR BUMPERS				
30	SKIS				
31					
32	TOTALS-RUNNING GEAR	(80.98)		(20.17)	
33	SHOCK STRUT-OIL-DAMPER			44.23	
34	STRUTS-DRAG	30.83		7.14	
35	-SIDE	10.10			
36	-VEE BRACE	15.09			
37	PYLON				
38	SHOCK STRUT-STRUT	79.14			
39	-STRUT OIL	3.40			
40	-FORK				
41	-AXLE				
42	-TORQUE ARMS	5.00			
43	-TRUNNIONS				
44	SHIMMY DAMPER OR SNUBBER				
45	TWO POSITION LINKAGE	29.43			
46	FITTINGS-MAIN ATTACH-WING				
47	-TAIL				
48	-BODY	45.58		3.94	
49	-NACELLE				
50					
51	FAIRING				
52	GROUND FEELER PROBE	.02			
53	INSULATION	31.23			
54	PINS, BOLTS, NUTS, ETC	1.15			
55	COLUMN TOTALS	339.21		75.48	
56	PAGE TOTAL				414.69
57					

TIRE SIZE: MAIN 20 x 4.4 NOSE: 18 x 4.4
 BRK ENERGY FT#/1000/AIRPL 2,800 NORMAL 3,900 RTO
 BRAKE TYPE : SINGLE DISK

AN 9102-D-TAB
NAME
DATE

ALIGHTING GEAR GROUP
CONTROLS
MAIN GEAR

PAGE 43
MODEL REPORT 64B148

1	LOCATION	X		XX		TWO
2			BRAKE	EMERG		POSITION-
3		RETRACT	OPER	EXTEN	RETRACT	EXTEN
4						ING CON-
5						TROLS
6	MECHANICAL OPERATING MECH					
7	CONTROLS		2.40			
8	ACTUATORS					
9						
10						
11						
12	ELECTRICAL OPERATING MECH					
13	CONTROLS	1.04				
14*	CIRCUITRY	4.13		.24		1.13
15	OPERATING MOTORS					
16	MECHANISM					
17						
18						
19						
20	HYDRAULIC OPERATING MECH					
21	CONTROLS					
22*	PLUMBING	3.97	6.84			.48
23	SELECTOR VALVES	1.36				1.34
24	SEQUENCE VALVES	.68				
25	ACCUMULATORS					
26	ACTUATORS	7.06				7.40
27	MECHANISM					
28*	FLUID	.04	.24			.08
29						
30						
31	PNEUMATIC OPERATING MECH					
32	CONTROLS			1.65		
33*	PLUMBING			3.50		
34	PUMPS					
35	BOYLES-AIR					
36	ACTUATORS					
37	MECHANISM					
38	UNLATCH OPER. MECH.					
39	ACTUATOR	.97				
40	MECHANISM AND PLUMBING	8.83				
41	LOCKING MECHANISM					
42	BRACES					
43	LINKS					
44	PARKING BRAKE CONTROL					
45	POSITION INDICATING MECH	5.10				
46						
47						
48	SUPTS, GUIDES, ETC-WING					
49	-TAIL					
50	-BODY	.17	1.50	.00		.1
51	-NACELLE					
52						
53						
54						
55	COLUMN TOTALS	10.13	10.78	3.84		10.58
56	PAGE TOTAL					60.5
57						

* FROM MAIN DISTRIBUTION POINT TO ACTUATING UNIT.

AN 9102-D-TAB
 NAME
 DATE

ALIGHTING GEAR GROUP
 CONTROLS
 CONTD
 NOSE GEAR

PAGE 45
 MODEL
 REPORT 64B148

LOCATION	X	BRAKE	EMERG	XX	EMERG
	STEERING	OPER	EXTEN	RETRACT	EXTEN
2					
3					
4					
5					
6	MECHANICAL OPERATING MECH				
7	CONTROLS				
8	ACTUATORS				
9					
10					
11					
12	ELECTRICAL OPERATING MECH				
13	CONTROLS				
14*		.77	.26		
15	OPERATING MOTORS				
16	MECHANISM				
17					
18					
19					
20	HYDRAULIC OPERATING MECH				
21	CONTROLS				
22*		2.81			
23	PUMPS				
24	RESERVOIRS				
25	ACCUMULATORS				
26		2.18			
27	MECHANISM				
28*		.10			
29					
30					
31	PNEUMATIC OPERATING MECH				
32	CONTROLS				
33*			.28		
34	PUMPS				
35	BOTTLES-AIR				
36	ACTUATORS				
37	MECHANISM				
38					
39					
40					
41	LOCKING MECHANISM				
42	BRACES				
43	LINKS				
44	PARKING BRAKE CONTROL				
45*		.52			
46					
47					
48	SUPTS, GUIDES, ETC-WING				
49	-TAIL				
50		.09			
51	-NACELLE				
52					
53					
54					
55	COLUMN TOTALS				
56	PAGE TOTAL				
57	TOTAL-ALIGHTING GEAR GROUP - PG 12-14				

* FROM MAIN DISTRIBUTION POINT TO ACTUATING UNIT.

AN 9102-D-TAB
 NAME
 DATE

SURFACE CONTROLS GROUP
 COCKPIT AND AUTOPILOT

PAGE 47
 MODEL
 REPORT 64B148

				COCKPIT CONTROLS	AUTO- PILOT
1					
2					
3					
4	CONTROL COLUMN OR STICK				
5	-PILOT			3.67	
6	-ASSISTANT PILOT				
7	-CONNECTING MEMBERS			6.79	
8	-SUPPORTS				
9					
10					
11					
12					
13	RUDDER PEDALS & BRK TREAD				
14	-PILOT			6.44	
15	-ASSISTANT PILOT				
16	-CONNECTING MEMBERS				
17	-SUPPORTS			.57	
18	-ADJUSTING MECHANISM			1.35	
19	LIFT STICK			5.25	
20	LIFT STICK MECHANISM			.38	
21					
22					
23	INTEGRAL PARKING LOCK				
24	CONTROL STICK				
25	RUDDER PEDALS				
26	SURFACES				
27					
28					
29					
30					
31					
32					
33	AUTOPILOT-TYPE-				
34	CONTROLLER				
35	TRANSMITTER				
36	SERVO AMPLIFIER				
37	SERVO MOTORS				
38	GYROS				
39					
40	AUTO STABILIZATION SYSTEM				
41	CONTROLLER				
42	ELECTRICAL CIRCUITRY				
43					
44					
45					
46	SUPPORTS AND BRACKETS				
47					
48*	PLUMBING				
49*	FLUID				
50*	ELEC PANELS & CIRCUITRY				
51	PULLEYS, SPROCKETS, ETC				
52					
53					
54					
55	COLUMN TOTALS			24.45	40.72
56	TOTAL-COCKPIT CONTROLS & AUTOPILOT				65.17
57					

* FROM MAIN DISTRIBUTION POINT TO ACTUATING UNIT.

AN 9102-D-TAB
 NAME
 DATE

SURFACE CONTROLS GROUP
 SYSTEM CONTROLS

PAGE 49
 MODEL
 REPORT 64B148

CONVENTIONAL

	AILERON	ELEVATOR	RUDDER	T.C.E. FLAPS	HORIZONTAL SPEED STABILIZER	BRAKES
1						
2						
3						
4						
5	MECHANICAL OPERATING MECH	18.88	5.25	3.42		
6	CONTROLS		7.61	6.74		
7	TENSION REGULATORS		4.20	4.12		
8	ACTUATORS					
9	TRIM CONTROLS					
10						
11	ELECTRICAL OPERATING MECH					
12	**TYPE					
13	CONTROLS					
14*	CIRCUITRY	.40		.75	2.81	6.21
15	OPERATING MOTORS				11.72	
16	MECHANISM					
17	TRIM CONTROLS	1.58		1.57		1.75
18						
19	HYDRAULIC OPERATING MECH					
20	**TYPE	"B"				"P"
21	CONTROLS					
22*	PLUMBING	5.37				14.89
23	PUMPS					
24	RESERVOIRS					
25	ACCUMULATORS					
26	ACTUATORS	6.30				14.47
27	MECHANISM					
28	TRIM CONTROLS					
29*	FLUID	.39				1.63
30						
31	PNEUMATIC OPERATING MECH					
32	**TYPE					
33	CONTROLS					
34*	PLUMBING					
35	PUMPS					
36	BOTTLES-AIR					
37	ACTUATORS					
38	MECHANISM					
39	TRIM CONTROLS					
40						
41	ARTIFICIAL FEEL					
42	BUNGE					
43	BOB WEIGHT					
44	AILERON DROOP SYSTEM					
45	MECHANICAL COMPONENTS	3.47				
46	ELECTRICAL ACTUATOR	1.00				
47	CIRCUITRY	.32				
48	SUPPORTS, GUIDES, ETC-WING	2.73				
49	-TAIL					.40
50	-BODY	.73	4.07	2.94	1.17	.12
51	-NACELLE					
52						
53						
54						
55	COLUMN TOTALS	41.31	21.13	19.54	15.70	39.47
56	PAGE TOTAL					137.15
57						

* FROM MAIN DISTRIBUTION POINT TO ACTUATING UNIT.
 ** TYPE- ADD P-POWERED OR B-BOOST.

AN 9102-D-TAB
 NAME
 DATE

SURFACE CONTROLS GROUP
 SYSTEM CONTROLS
 CONTD
 VTOL

PAGE 51
 MODEL
 REPORT 04B148

	PITCH	YAW	ROLL	LIFT	COMMON	
1						
2						
3						
4						
5	MECHANICAL OPERATING MECH	13.41	1.26	.40	13.38	34.54
6	CONTROLS					
7	TENSION REGULATORS					
8	ACTUATORS					
9	TRIM CONTROLS					
10						
11	ELECTRICAL OPERATING MECH					
12	**TYPE					
13	CONTROLS	3.70				
14	* CIRCUITRY	.63	.32	.26	.58	8.20
15	OPERATING MOTORS				2.71	
16	MECHANISM					
17	TRIM CONTROLS	.81	.97	.86		
18	CIRCUITRY-INTERLOCK					14.68
19	HYDRAULIC OPERATING MECH					
20	**TYPE					
21	CONTROLS					
22	* PLUMBING	5.91			8.36	
23	PUMPS					
24	RESERVOIRS					
25	ACCUMULATORS					
26	ACTUATORS	9.60			53.56	
27	MECHANISM					
28	TRIM CONTROLS					
29	* FLUID	.81			.87	
30						
31	PNEUMATIC OPERATING MECH					
32	**TYPE					
33	CONTROLS					
34	* PLUMBING					
35	PUMPS					
36	BOTTLES-AIR					
37	ACTUATORS					
38	MECHANISM					
39	TRIM CONTROLS					
40						
41	ARTIFICIAL FEEL					
42	BUNGEE					
43	BOB WEIGHT					
44	ELECTRICAL MIXER					27.00
45						
46						
47						
48	SUPPORTS, GUIDES, ETC-WING				21.00	
49	-TAIL					
50	-BODY	3.37			.66	
51	-NACELLE					
52						
53						
54						
55	COLUMN TOTALS	25.24	2.55	2.06	210.60	344.12
56	PAGE TOTAL					440.00
57	TOTAL-SURFACE CONTROLS GROUP - PG 15-17					440.00

* FROM MAIN DISTRIBUTION POINT TO ACTUATING UNIT.

** TYPE - ADD 2-POWERED OR 2-UNPOWERED

AN 9102-D-TAB
 NAME
 DATE

ENGINE SECTION
 OR
 NACELLE GROUP

PAGE 23
 MODEL
 REPORT 64B148

					INBOARD	CENTER	OUTBOARD
1							
2							
3							
4	ENGINE MOUNT					14.34	
5							
6	SUPPORT BAY						
7	VIBRATION ABSORBERS						
8							
9							
10	NACELLE STRUCTURE						
11	BULKHEADS AND FRAMES						
12	COVER AND STIFFENERS						
13	FITTINGS						
14	LONGERONS						
15	ATTACHING ANGLES, ETC						
16							
17							
18							
19	PYLON AND STRUTS						
20							
21							
22							
23*	FIREWALL					30.21	
24							
25	FIRE PROTECTION SHROUDS						
26							
27	COWLING						
28	ENGINE COWL						
29							
30							
31							
32							
33							
34							
35	BAFFLES						
36	ACCESSORY COWL OR SKIRT						
37	COWL FLAPS						
38	COWL FLAP CONT & MECH						
39							
40							
41							
42							
43							
44							
45	FAYRING-NAC TO WING-PYLON						
46	STEPS AND GRIPS						
47	WORKING PLATFORMS-BUILT IN						
48	INTERNAL WALKWAYS						
49							
50							
51	INSTALLATION HARDWARE						
52							
53							
54							
55	COLUMN TOTALS					44.55	
56	PAGE TOTAL						44.55
57							

* IF IN NACELLE OR NON STRUCTURAL IN WING OR BODY

AN 9102-D-TAB
 NAME
 DATE

PROPULSION GROUP
 MAIN
 GAS GENERATOR

PAGE 55
 MODEL
 REPORT 64P148

	ENGINE INSTL	GEAR BOX & DRIVES	SUPER- CHARGER	AIR INDUCT.	EXHAUST SYSTEM	COOLING SYSTEM
1						
2						
3						
4	ENGINE INSTALLATION					
5	ENGINE & DIVERTER VALVE	935.90				
6	AFTERBURNER					
7	ENGINE AND AFTERBURNER					
8	REDUCTION GEAR BOX					
9	EXTENSION DRIVE SHAFT					
10						
11	ACCESS. GEAR BOX & DRIVES	19.60				
12	DRIVE SHAFT	8.64				
13	SUPERCHARGER-FOR TURBOS					
14	LUBRICATING SYSTEM					
15	SUPPORTS					
16	CONTROLS					
17	PIPING-EXH TO SUPCHGR					
18						
19	AIR INDUCTION SYSTEM					
20	INTERCOOLERS & SUPPORTS					
21	AIR DUCTS AND SHROUDING					
22	INTAKE DOORS & CONTROLS					
23	AIR FILTERS					
24	SCREENS AND CONTROLS					
25	COMPRESSOR BLEED DUCT					
26						
27						
28	EXHAUST SYSTEM					
29	EXHAUST STACKS					
30	EXHAUST COLLECTORS					
31	COLLECTOR OR ENG SHROUD					
32	TAILPIPE					
33	TAILPIPE SHROUD & INSUL					
34	TAIL CONE					
35	SILENCING DEVICES					
36	SUPPORTS, BRACKETS, ETC					
37	THRUST SPOILER DOORS					
38	THRUST SPOILER LINKAGE					
39	COOLING SYSTEM					
40	RADIATOR AND SUPPORTS					
41	SHUTTERS, SCOOPS, DUCTS					
42	EXPANSION TANK & SUPTS					
43	LIQ IN SYSTEM- GAL					
44	PIPING, VENTS, CLAMPS, ETC					
45	EJECTOR					
46						
47	FANS					
48	CONTRAVANES					
49	FAN DRIVES					
50	CONTROLS & OPER MECH					
51						
52						
53						
54						
55	COLUMN TOTALS	935.90	18.24	63.08	220.47	10.50
56	PAGE TOTAL					1257.92
57						

* AS INSTALLED WEIGHT

AN 9102-D-TAB
 NAME
 DATE

PROPULSION GROUP
 MAIN
 LIFT FAN

PAGE 57
 MODEL
 REPORT 64B148

	ENGINE INSTL	GEAR BOX & DRIVES	SUPER- CHARGER	AIR INDUCT.	EXHAUST SYSTEM	COOLING SYSTEM
1						
2						
3						
4	ENGINE INSTALLATION					
5*	FAN X353-5B (2)	1765.74				
6	AFTERBURNER					
7*	ENGINE AND AFTERBURNER					
8	REDUCTION GEAR BOX					
9	EXTENSION DRIVE SHAFT					
10	FAN MOUNTS	8.06				
11	ACCESS, GEAR BOX & DRIVES					
12						
13	SUPERCHARGER-FOR TURBOS					
14	LUBRICATING SYSTEM					
15	SUPPORTS					
16	CONTROLS					
17	PIPING-EXH TO SUPCHGR					
18						
19	AIR INDUCTION SYSTEM					
20	INTERCOOLERS & SUPPORTS					
21	AIR DUCTS AND SHROUDING			100.28		
22	INTAKE DOORS & CONTROLS					
23	AIR FILTERS					
24	SCREENS AND CONTROLS					
25	INSULATION			16.63		
26	DUCT SUPPORTS			15.03		
27						
28	EXHAUST SYSTEM					
29	EXHAUST STACKS					
30	EXHAUST COLLECTORS					
31	COLLECTOR OR ENG SHROUD					
32	TAILPIPE					
33	TAILPIPE SHROUD & INSUL					
34	TAIL CONE					
35	SILENCING DEVICES					
36	SUPPORTS, BRACKETS, ETC					
37						
38						
39	COOLING SYSTEM					
40	RADIATOR AND SUPPORTS					
41	SHUTTERS, SCOOPS, DUCTS					
42	EXPANSION TANK & SUPTS					
43	LIG IN SYSTEM- GAL					
44	PIPING, VENTS, CLAMPS, ETC					
45	EJECTOR					
46						
47	FANS					
48	CONTRAVANES					
49	FAN DRIVES					
50	CONTROLS & OPER MECH					
51						
52						
53						
54						
55	COLUMN TOTALS	1773.80		131.94		
56	PAGE TOTAL					1905.74
57						

* AS INSTALLED WEIGHT

AN 9102-D-TAB
NAME
DATE

PROPULSION GROUP
AUXILIARY

PAGE 09
MODEL
REPORT 64B148

PITCH FAN

	ENGINE IN STL	GEAR BOX & DRIVES	SUPER- CHARGER	AIR INDUCT.	EXHAUST SYSTEM	COOLING SYSTEM
1						
2						
3						
4	ENGINE INSTALLATION					
5*	FAN - X376 (1)	114.15				
6	AFTERBURNER					
7*	ENGINE AND AFTERBURNER					
8	REDUCTION GEAR BOX					
9	EXTENSION DRIVE SHAFT					
10	FAN SUPPORTS	2.27				
11	ACCESS, GEAR BOX & DRIVES					
12						
13	SUPERCHARGER-FOR TURBOS					
14	LUBRICATING SYSTEM					
15	SUPPORTS					
16	CONTROLS					
17	PIPING-EXH TO SUPCHGR					
18						
19	AIR INDUCTION SYSTEM					
20	INTERCOOLERS & SUPPORTS					
21	AIR DUCTS AND SHROUding					
22	INTAKE LOUVRES			61.54		
** 23	AIR FILTERS			18.59		
24	SCREENS AND CONTROLS					
25	DUCT SHROUding			39.12		
26	DUCT SUPPORTS			5.74		
27	BELLMOUTH			20.40		
28	EXHAUST SYSTEM					
29	EXHAUST STACKS					
30	EXHAUST COLLECTORS					
31	COLLECTOR OR ENG SHROUD					
32	TAILPIPE					
33	TAILPIPE SHROUD & INSUL					
34	TAIL CONE					
35	SILENCING DEVICES					
36	SUPPORTS, BRACKETS, ETC					
** 37	PITCH THRUST REVERSER				75.57	
** 38	THRUST REVERSER LINKAGE				8.80	
39	COOLING SYSTEM					
40	RADIATOR AND SUPPORTS					
41	SHUTTERS, SCOOPS, DUCTS					
42	EXPANSION TANK & SUPTS					
43	LIQ IN SYSTEM- GAL					
44	PIPING, VENTS, CLAMPS, ETC					
45						
46						
47	FANS					
48	CONTRAVANES					
49	FAN DRIVES					
50	CONTROLS & OPER MECH					
51						
52						
53						
54						
55	COLUMN TOTALS	116.42		136.39	84.37	
56	PAGE TOTAL					337.18
57						

* AS INSTALLED WEIGHT

** FOR ACTUATING MECHANISM & CONTROLS SEE
PAGE 17 "VTOL CONTROLS"

AN 9102-D-TAB
 NAME
 DATE

PROPULSION GROUP
 LUBRICATING AND FUEL SYSTEMS

PAGE 61
 MODEL
 REPORT 64B148

1	2	3	4	X AUXILIARY XX		MAIN X		
				LUBRI- CATING	FUEL	LUBRI- CATING	FUEL	
5	6	7	8					
	TYPE	LOC	QTY	VOL-EA GAL				
9	TANKS							
6	BLADDER - FWD.FUS.		1	246			18.88	
7	METAL - AFT FUS.		1	128			34.54	
8								
9								
10								
11	AUXILIARY TANK - AFT FUS.							
12	METAL-	AFT FUS.	1	120				
13	NOT INCL. IN WT. EMPTY							
14								
15								
16								
17								
18								
19								
20	INTEG TANK SEALS & SEALANT							
21	BACKING BOARD							8.85
22	TANK SUPPORTS AND PADDING							2.19
23	TANK BAY SEALING							2.80
24								
25	TANK RELEASE AND CONTROLS							
26	OIL COOLING INSTALLATION							
27*	COOLERS AND SUPPORTS							
28	DUCTS AND SHUTTERS							
29	AUTO OIL TEMP VALVE							
30	SHUTTER CONTROLS							
31								
32	FUEL VAPOR RECOVERY							
33								
34	OIL DILUTION SYSTEM							
35								
36	VAPOR INERTION-CYL & SUPT							
37	-GENERATOR							
38	-CONTROLS							
39	PUMP INSTALLATION QTY							
40	ENGINE DRIVEN							
41	BOOSTER							14.22
42	HAND-INCL CONTROLS							
43	TRANSFER							
44	FUEL VALVE POSITION IND.							.20
45								
46	FILLING SYSTEM-GROUND							4.33
47	-IN FLIGHT							
48	ENGINE DRAIN SYSTEM							10.10
49	DISTRIBUTION SYSTEM							20.59
50	TRANSFER SYSTEM							
51	VENT SYSTEM							5.85
52	PRESSURIZATION SYSTEM							
53	DUMP SYSTEM							
54	WARNING SYST. - LOW PRESSURE							1.84
55	COLUMN TOTALS							2.19
56	PAGE TOTAL							122.20
57								124.39

* OIL COOLER-QTY • SIZE •

AN 9102-D-TAB
 NAME
 DATE

PROPULSION GROUP
 MAIN

PAGE 03
 MODEL
 REPORT 04B148

	WATER INJECT.	ENGINE CONTROLS	STARTING SYSTEM	PROP INSTR	
1					
2					
3					
4	WATER INJECTION SYSTEM				
5*	TANKS				
6	PUMPS				
7	METERING UNIT				
8	VALVES AND PLUMBING				
9	CONTROLS				
10					
11					
12	ENGINE CONTROLS				
13		.68			
14		19.74			
15		13.91			
16***	SUPERCHARGER				
17	AFTERBURNER				
18		8.57			
19					
20	STARTING SYSTEM - AIR IMPINGEMENT			8.21	
21	POWER UNIT-TYPE				
22	STARTER-TYPE				
23	STARTER CONTROLS				
24	CRANK AND EXTENSION				
25	PRIMER AND PIPING				
26	MESHING SOLENOID				
27	CIRCUITRY				
28					
29					
30					
31					
32	PROPELLER INSTL-DIA				
33	PROPELLER-QTY				
34	CUFFS				
35	SPINNER				
36	CONTROLS-TYPE	GFAE			
37	SPEED				
38	PITCH				
39	FEATHER				
40	REVERSE				
41					
42					
43					
44					
45					
46					
47**	OIL	GAL			
48**	TANK AND PLUMBING				
49					
50					
51					
52					
53					
54					
55	COLUMN TOTALS			42.90 8.21	
56	PAGE TOTAL				51.11
57	TOTAL PROPULSION GROUP				3617.65

* WATER TANKS-QTY , GAL PER TANK
 ** WHEN SEPARATE OIL SYSTEM IS USED.
 ***SUPERCHARGER INTEGRAL WITH ENGINE.

AN 9102-D-TAB
 NAME
 DATE

INSTRUMENT AND NAVIGATIONAL
 EQUIPMENT GROUP
 INSTRUMENTS

PAGE 65
 MODEL 64B148
 REPORT

1					X INSTRMT
2	FUNCTIONAL GROUPS			TRANSM	POWER
3	AND ITEMS	QTY	INDIC	& AMPL	INSTL
4	ACCELEROMETER		.00		
5	MACHMETER		1.05		.39
6	ALTIMETER		1.31		
7	ATTITUDE		2.86		.21
8	AIR SPEED - LOW SPEED		.00		
9					
10					
11	TURN AND BANK		1.20		.11
12	FLAP-THRUST SPOIL. POSITION		.57	.10	1.04
13	STANDBY COMPASS		.7		.21
14	LANDING GEAR POSITION		.32		1.43
15	FUEL QUANTITY		1.82	3.71	2.38
16	FUEL FLOW		1.40	4.90	3.14
17	OIL PRESSURE - DUAL		.63	2.70	3.74
18	ENGINE TACHOMETER (2)		.98		1.08
19	LANDING GEAR WARNING		.05		
20	HYDRAULIC PRESSURE		.87	3.00	1.19
21	PILOT SYSTEM				9.82
22	CLOCK		.43		
23	ALPHA METER - ANGLE ATTACK		.63		
24	ANGLE OF YAW		.63		
25	VECTOR ANGLE		.26		
26	EXHAUST TEMP - DUAL		1.25		2.38
27	VERTICAL SPEED		1.46		
28					
29	RUD., AIL., HORIZ. STAB. POS.		1.11		3.02
30	LOUVER POSITION		1.11		.16
31					
32					
33					
34					
35					
36					
37					
38					
39	MASTER CAUTION IND.		.13		
40	MASTER CAUTION PNL.		1.41		1.36
41					
42					
43					
44					
45					
46					
47					
48					
49					
50	CONSOLE VIBRATOR				.90
51					
52					
53	ATTACHING PARTS				.58
54	SWITCHES, ETC.				.71
55	COLUMN TOTALS		24.16	16.47	34.45
56	TOTAL-INSTRUMENTS				73.08
57					

LIST ITEMS BY FUNCTIONAL GROUPS- FLIGHT, ENGINE & MISC. LIST SUB-GROUPS BY CREW STATION. ADD SUPPLEMENTAL PAGE 26A IF NECESSARY.

AN 9102-D-TAB
 NAME
 DATE

* HYDRAULIC AND PNEUMATIC GROUP

PAGE 67
 MODEL
 REPORT 64B148

1	2	3	X HYDRAULIC		XX PNEUMATIC	
			UTILITY	EMERG	UTILITY	EMERG
4	PUMPS, COMPRESSORS MODEL					
5	PUMPS - ENGINE DRIVEN (2)		14.32			
6						
7						
8	OIL COOLERS (2)		6.10			
9						
10						
11						
12	REMOTE PUMP DRIVES					
13		QTY CAP. EA				
14	RESERVOIRS	2 272 IN ²	14.30			
15						
16	AIR BOTTLES					***
17						
18						
19	ACCUMULATORS		7.43			
20	ACCUMULATOR CHARGE FIG.		.80			
21	FILTERS		6.64			
22	PRESSURE REGULATORS					
23	PRESSURE SWITCH		.74			
24	VALVES					
25	CHECK		.16			
26						
27	RELIEF		2.92			
28	CONTROL		.15			
29						
30	CONTROLS					
31	TEMPERATURE INDICATION		.94			
32	LOW PRESS. WARNING		.38			
33	QUICK DISCONNECTS		1.04			
34						
35	PLUMBING		25.39			1.96
36						
37						
38	FLUID IN SYSTEM		25.62			
39	TYPE MIL-O-5606					
40	CAPACITY 3.66 GAL					
41						
42	SUPPORTS-WING					
43	-TAIL					
44	-BODY		6.54			
45	-NACELLE					
46	FURNISHES POWER FOR **					
47						
48	SEE FOLLOWING PAGE					
49						
50						
51						
52						
53						
54						
55	COLUMN TOTALS		113.47			1.96
56	PAGE TOTAL					115.43
57	TOTAL-HYDRAULIC AND PNEUMATIC GROUP					115.43

SYSTEM PRESSURE PSI 3000

* INCLUDES SYSTEM FROM SOURCES OF POWER TO MAIN DISTRIBUTION POINTS.

** LIST ITEMS AND INDICATE H-HYDRAULIC, P-PNEUMATIC

*** SEE NEXT PAGE

HYDRAULIC SYSTEM FURNISHES POWER FOR:

Wing Fan Doors
Main Landing Gear Doors
" " " Retraction
" " " Uplatch
" " " Brakes
" " " Two Positioning
Nose " " Retraction
Aileron
Horizontal Stabilizer
VTOL Pitch, Roll and Yaw Control
VTOL Lift Controls
Diverter Valve
Thrust Spoiler

PNEUMATIC SYSTEM SUPPLIES POWER FOR:

Main Landing Gear Emergency Extension
Nose Landing Gear Emergency Extension
Wing Fan Overspeed Control

*** Upper portion of main landing gear struts contain 210 cu. in. of dry nitrogen at 3000 psig for pneumatic system supply.

AN 9102-D-TAB
 NAME
 DATE

**** ELECTRICAL GROUP
 A.C. SYSTEM**

PAGE
 MODEL
 REPORT 64-B1-8

		POWER SUPPLY	POWER CONVER	DISTR & CONT	LIGHTS- SIGNALS	EQUIP. SUPPORTS
1						
2						
3						
4	POWER SUPPLY* KVA VOLT QTY					
5	GENERATORS					
6						
7						
8						
9						
10	REMOT ⁿ GENERATOR DRIVES					
11						
12						
13						
14	POWER CONVERSION QTY					
15	CONVERTER AC-DC					
16	TRANSFORMER		.81			
17	RECTIFIER					
18	MOTOR-GENERATOR					
19	PHASE ADAPTER					
20	FREQUENCY CONVERTER					
21						
22						
23						
24	POWER DISTRIBUTION & CONT					
25	GENERATOR CONTROL BOXES					
26	CUTOUTS, VOLT REGULATORS					
27	AMMETERS AND VOLTMETERS					
28	SWITCHES, RHEO & PANELS					
29	CIRCUIT BREAKERS & FUSES					
30	JUNCT, FUSE & DIST BOXES					
31	RECEPT & CONNECTOR PLUGS					
32	RELAYS			2.28		
33	WIRING			.86		
34	CONDUIT			.76		
35						
36	LIGHTS AND SIGNAL DEVICES					
37	LIGHTS-INTERIOR					
38	-EXTERIOR - WIRING ONLY				1.11	
39	-LANDING-INCL MECH					
40						
41	SIGNAL DEVICES-LIGHTS					
42	-HORNS					
43	-BELLS					
44						
45	EQUIPMENT SUPPORTS-WING					
46	-TAIL					
47	-BODY					
48	-NACELLE					
49	FURNISHES POWER FOR					
50	SEE FOLLOWING PAGE					
51						
52						
53						
54						
55	COLUMN TOTALS		.81	4.90	1.11	
56	TOTAL- AC SYSTEM					6.81
57						

* DRIVEN BY- 5

** INCLUDES SYSTEM FROM SOURCE OF POWER TO MAIN DISTRIBUTION POINTS.

RYAN

REPORT NO.
64B148

WEIGHT AND BALANCE REPORT
XV-5A

PAGE 73

A.C. SYSTEM FURNISHES POWER FOR:

Engine Ignition
Amplifier-Start./Augment
3 Axis Rate Gyro
Indicator-Fuel Quantity
Xmtr-Hyd Press.
Ind-Hyd Press.
Xmtr-Eng Oil Press.
Ind-Eng Oil Press.
Ind-Attitude

Valve-Engine Anti-Ice
Xmtr-Fuel Flow
Indicator-Fuel Flow
Flight Instrumentation

AN 9102-D-TAB
 NAME
 DATE

** ELECTRICAL GROUP
 D.C. SYSTEM

PAGE
 MODEL
 REPORT

		POWER SUPPLY	POWER CONVER	DISTR & CONT	LIGHTS- SIGNALS	EQUIP. SUPPORTS
1						
2						
3						
4	POWER SUPPLY* VOLT AMP QTY					
5	GENERATORS 265 2	74.00				
6						
7						
8						
9						
10	REMOTE GENERATOR DRIVES					
11	BATTERY--AN	18.00				
12	BATTERY CONTAINER, SUPTS	.90				
13						
14	POWER CONVERSION QTY					
15	INVERTER DC-AC 250VA		2.00			2.00
16	MOTOR-GENERATOR					
17						
18						
19						
20						
21						
22						
23						
24	POWER DISTRIBUTION & CONT					
25	GENERATOR CONTROL BOXES			13.24		
26	CUTOUPS, VOLT, REGULATORS					
27	AMMETERS AND VOLTMETERS			1.06		
28	SWITCHES, RHEO & PANELS			.27		
29	CIRCUIT BREAKERS & FUSES			10.06		
30	JUNCT, FUSE & DIST BOXES			2.23		2.00
31	RECEPT & CONNECTOR PLUGS			1.84		
32	RELAYS			7.11		
33	WIRING		4.38	23.47		
34	CONDUIT			1.87		
35	BONDING INST'L.			.48		
36	LIGHTS AND SIGNAL DEVICES					
37	LIGHTS-INTERIOR					
38	-EXTERIOR					
39	-LANDING-INCL MECH					
40						
41	SIGNAL DEVICES-LIGHTS					
42	-HORNS					
43	-BELLS					
44						
45	EQUIPMENT SUPPORTS-WING					1.08
46	-TAIL					
47	-BODY					2.50
48	-NACELLE					
49	FURNISHES POWER FOR					
50	SEE FOLLOWING PAGE					
51						
52						
53						
54						
55	COLUMN TOTALS	92.96	28.44	61.63		0.70
56	TOTAL DC SYSTEM					189.70
57	TOTAL ELECTRICAL GROUP - PG 29-30					190.40

* DRIVEN BY- 5 . 6 . 7 . 8 . 9
 ** INCLUDES SYSTEM FROM SOURCE OF POWER TO MAIN DISTRIBUTION POINTS.

RYAN

REPORT NO.
C-81-8

WEIGHT AND BALANCE REPORT
XV-5A

PAGE 77

D.C. SYSTEM FURNISHES POWER FOR:

FLIGHT CONTROLS

Sol Valve-Wing Fan Doors
 Sol Valve-Diverter
 Sol Valve-Stab/Fan Speed
 Sol Valve-Stab/High Speed
 Sol Valve-Stab/Trim
 Sol Valve-Spoilers
 Sol Valve-Low Airspeed Ind.
 Actr-Aileron Trim
 Actr-Rudder Trim
 Actr-VTOL Roll Trim
 Actr-VTOL Yaw Trim
 Actr-VTOL Pitch Trim
 Actr-Thrust Vector
 Actr-Wing Fan Door Latch
 Actr-Pitch Fan Inlet Lever
 Actr-Aileron Droop
 Actr-Wing Flaps
 Relay-Wing Flaps Control
 Controller-Stab/Aug System
 Flight Control Electrical Mixer

INSTRUMENT

Fan Speed Ind. and Limiting Control
 Sol Valve-Throttle Cutback
 Ind-Vector Angle
 Ind-Flap/Spoiler
 Ind-VTOL Trim
 Ind-CTOL Trim
 Ind-Landing Gear Position

FLIGHT INSTRUMENT

Ind-Turn and Slip
 Test Instrumentation (F.T.)

LANDING GEAR

Sol Valve-Nose Gear
 Sol Valve-Main Gear
 Sol Valve-Main Gear Door
 Sol Valve-Main Gear Mode

POWER

Inverter
 Relay-Battery
 Relay-Emer. Bus.
 Relay-Nonessential Bus
 Relay-Gen. Monitor

FUEL AND OIL

Sol Valve-Fuel Booster Pump
 Motor Valve-Fwd. Fuel Tank
 Motor Valve-Aft Fuel Tank
 Motor Valve-Fuel Cross-over

RADIO

Transmitting
 Receiving

DC CONTROL FOR AC POWER

Relay-Inverter On/Off

WARNING

Fire Detect and Structure O'heat
 Fans Frame and Bearing O'heat
 Annunciator Panel
 Sig.Gen.-Audible Warning
 Lamp-Condition (MS25331)
 Diverted (Fan Mode)
 Fan Doors Locked
 Fan Doors Unlocked
 Stab.Aug.-Pri.
 Stab.Aug.-Stby.
 Landing Gear STOL
 Pwr. Bus Monitors

AN 9102-D-TAB
 NAME
 DATE

ELECTRONICS GROUP

PAGE 79
 MODEL
 REPORT 042146

1	EQUIPMENT COMPONENTS AND 2 PART NUMBERS OR IDENT 3 LIST BY FUNCTIONAL GROUPS	X EQUIPMENT XX X		
		QFAE	CPE	INSL
4				
5	UHF TRANSCEIVER ARC/5LX			
6	TRANSCEIVER RT-702		30.30	.94
7				
8	ANTENNA AT 256A		1.54	.08
9	CABLING		3.16	
10	CONTROL UNIT C3984		3.00	
11				
12				
13				
14				
15				
16				
17				
18				
19				
20				
21				
22				
23				
24				
25				
26				
27				
28				
29				
30				
31				
32				
33				
34				
35				
36				
37				
38				
39				
40				
41				
42				
43				
44				
45				
46				
47	ELECTRONIC INSTALLATION			
48	TABLES			
49	RACKS, SHELVES & SUPPORTS			
50	LOCKERS			
51				
52				
53				
54				
55	COLUMN TOTALS			
56	PAGE TOTAL			
57	TOTAL-ELECTRONIC GROUP			

* LIST COMPONENTS- INCL RADOMES, MTS, ANT, SWITCHES, RELAYS, FILTERS, ETC FROM MAIN DISTRIBUTION POINT TO UNIT OPERATED, BY FUNCTIONAL GROUPS-E.G. COM, VHF, SEARCH, NAV, INTERCOMM, ETC. ADD SUPPLEMENTAL PG 31A IF NEC.

AN 9102-D-TAB
 NAME
 DATE

FURNISHINGS AND EQUIPMENT GROUP
 ACCOMODATIONS FOR PERSONNEL

PAGE 81
 MODEL
 REPORT 64B148

1	X CREW SEATS AND PASSENGER CHAIRS **		XX MISC X
2		ASST	ACCOM
3	PILOT	PILOT	& OXYGEN
4	SEATS AND CHAIRS		
5	CUSHION		
6	SEAT	148.80	
7	SAFETY BELT		
8	HARNES & INERTIA REEL		
9	ADJUSTING MECHANISM		
10	CATAPULT OR EJECT, MECH		
11	TRACKS AND SUPPORTS	17.72	
12	HEADREST		
13			
14			
15			
16			
17	MISC ACCOMODATIONS		
18	BUNKS AND SUPPORTS		
19			
20	LITTER SUPPORTS		
21	KNEELING PADS		
22	PARACHUTE STOWAGE PROV		
23	TOILET AND RELIEF TUBES		
24	WASH BASINS & SHOWERS		
25	WATER TANKS & PIPING		
26	DRINKING WATER PROV		
27	LOCKERS-FOOD		
28	LOCKERS-PERSONAL EFFECTS		
29			
30			
31			
32			
33	GALLEY STOVES, HOTPLATES		
34	REFRIGERATOR		
35			
36			
37			
38	ANTI-G SUIT PROVISIONS		
39			
40	OXYGEN INSTALLATION - INCLUDED WITH EJECTION SEAT		
41*	BOTTLES	TYPE SIZE QTY	
42			
43			
44			
45			
46	CONVERTER		
47*	REGULATORS		
48	SUPTS-BOTTLES, REGULATORS		
49	PLUMBING, ETC		
50			
51			
52			
53			
54			
55	COLUMN TOTALS	166.52	
56	TOTAL-PERSONNEL ACCOMODATIONS		166.52
57			

* OXYGEN BOTTLE INCLUDING CHARGE, IF NOT SPECIFIED AS USEFUL LOAD OR SPECIAL EQUIPMENT

** ADD ADDITIONAL PAGE 34A IF NECESSARY.

AN 9102-D-TAB
 NAME
 DATE

FURNISHINGS AND EQUIPMENT GROUP
 MISC EQUIPMENT AND FURNISHINGS

PAGE
 MODEL
 REPORT 64B148

						MISC	
						EQUIP	FURN
1							
2							
3							
4	MISCELLANEOUS EQUIPMENT						
5*	PORT, PLATFORMS, LADDERS						
9	BALANCE COMPUTER & SUPT						
6							
7	DATA CASES OR HOLDERS						
8	MANUALS-FLIGHT & MAINT						
10							
11							
12	TOOL LOCKERS						
13							
14	WINDSHIELD WIPER, WASHER						
15	REL MECH-TARGET & TOW						
16							
17	BILGE SYSTEM						
18	STALL WARNING DEVICES						
19	REAR VIEW MIRROR						
20							
21	AUXILIARY FLOORING						
22	INSTRUMENT BOARDS					4.91	
23	CONSOLES					5.61	
24	CONTROL STANDS						
25	INST. PANEL SUPPORTS					1.54	
26*	CARGO HANDLING EQUIPMENT						
27	RAMPS						
28	HOISTS AND BOOMS						
29	MONORAILS						
30	MONORAIL MOTORS						
31	TIE DOWN FITTINGS						
32							
33							
34							
35	PYROTECHNIC INSTALLATION						
36	SIGNAL PISTOL HOLDER						
37	AMMO HOLDER-CAP.-						
38	PARA FLARE						
39	-CONTAINER-CAP.-						
40	-RACKS -CAP.-						
41	-RELEASE MECHANISM						
42	SMOKE CANDLE-HANDLE						
43							
44	FLOATLIGHT RACK & REL						
45	CAP.-						
46	FURNISHINGS						
47	FLOOR COVERING, RUGS ETC						
48	SOUNDPROOFING & INSUL						
49	TRIM						
50	CURTAINS AND SCREENS						
51	CRASH PADDING						
52	PARTITIONS-NON STRUCT						
53							
54							
55	COLUMN TOTALS					12.06	
56	TOTAL-MISCELLANEOUS EQUIPMENT AND FURNISHINGS						12.06
57							

* IF NOT SPECIFIED AS SPECIAL EQUIPMENT

AN 9102-D-TAB
 NAME
 DATE

FURNISHINGS AND EQUIPMENT
 EMERGENCY EQUIPMENT

PAGE 85
 MODEL
 REPORT 64B1.48

1	X FIRE PREVENTION & DETECTION SYSTEMS				XX OTHER	
2	ENGINE	BAGGAGE	FUEL	OTHER	EMERG	
3	COMPT	COMPT	COMPT		EQUIP	
4	FIRE PREVENT AND DETECTION					
5	BOTTLES	TYPE	SIZE	QTY		
6	BOTTLES			2	12.44	
7						
8						
9						
10						
11						
12	PORTABLE					
13						
14						
15						
16	CONTROLS				3.17	
17	PLUMBING				4.93	
18	BOTTLE SUPTS-FIXED EXT				.20	
19						
20						
21	BOTTLE SUPTS-PORT. EXT					
22						
23						
24	FIRE DETECTION SYSTEM					
25	STRUCTURAL OVERHEAT WARNING				4.27	
26	FIRE RESISTANT PAINT					
27	FIRE CURTAINS					
28						
29	OTHER EMERGENCY EQUIPMENT					
30	FIRST AID KITS & SUPTS					
31	FLASHLIGHTS-QTY					
32						
33	STOWAGE-EMERG FOOD, WATER					
34						
35*	LIFE RAFTS	TYPE	QTY			
36						
37						
38						
39	LIFE RAFT SUPPORTS					
40						
41	DITCHING STATION EQUIP					
42						
43						
44						
45						
46						
47						
48						
49						
50						
51						
52						
53						
54						
55	COLUMN TOTALS				30.10	4.27
56	TOTAL-EMERGENCY EQUIPMENT					34.37
57	TOTAL-FURNISHINGS & EQUIPMENT GROUP - PG 34-36					212.95

* IF NOT SPECIFIED AS USEFUL LOAD OR SPECIAL EQUIPMENT.

AN 9102-D-TAB
 NAME
 DATE

AIR CONDITIONING AND ANTI-ICING
 EQUIPMENT GROUP
 AIR CONDITIONING

PAGE 87
 MODEL
 REPORT 64B148

			PRESS.	VENTIL	HEATING	COOLING
			SYSTEM	SYSTEM	SYSTEM	SYSTEM
1						
2						
3						
4	HEAT EXCHANGERS-QTY					
5						
6	HEATERS-BTU EA QTY					
7						
8						
9						
10						
11	HEATING FLUID- GAL					
12						
13	COMPRESSORS OR SUPCHGRS					
14						
15	MOTORS					
16	TURBINES					
17	FANS					13.53
18						
19						
20	TANKS					
21	WATER SEPARATOR					
22	REGULATOR					
23						
24						
25	SCOOPS					
26	DUCTING					14.42
27	SHROUDS					
28						
29	PLENUM CHAMBER					4.99
30	PLUMBING					
31						
32						
33	BOMB BAY HEATING					
34						
35						
36						
37						
38						
39	CONTROLS					
40	-MANUAL					
41						
42	-ELECTRICAL					
43						
44	-HYDRAULIC					
45						
46	-PNEUMATIC					
47						
48	SUPPORTS & BRACKETS-WING					
49	-TAIL					
50	-BODY					
51	-NACELLE					
52						
53						
54	PRESSURIZATION SEALING					
55	COLUMN TOTALS					33.15
56	TOTAL-AIR CONDITIONING					33.15
57						

* IF NOT SPECIFIED AS SPECIAL EQUIPMENT.

AN 9102-D-TAB
 NAME
 DATE

AIR CONDITIONING AND ANTI-ICING
 EQUIPMENT GROUP
 ANTI-ICING

PAGE 89
 MODEL XV-5A
 REPORT 64B148

1									
2									
3				WING	TAIL	AIR INDUCT.	ENGINE	CANOPY & WINDSHLD	FUEL SYSTEM
4	*HEATERS	BTU	EA	QTY					
5									
6									
7									
8									
9									
10									
11	*HEAT EXCHANGERS								
12									
13									
14									
15	DUCTING								
16	SHROUDING								
17									
18									
19	*BOOTS								
20									
21	*ATTACHING STRIPS								
22									
23	OIL SEPARATORS								
24									
25	AIR PUMPS								
26									
27	AIR LINES AND HOSES								
28									
29	TANKS								
30									
31	*FLUID-			GAL					
32									
33									
34									
35	PLUMBING								
36									
37									
38	DISTRIBUTOR								
39	-VALVE								
40	-CONTROLS								
41									
42	CONTROLS								
43	-MANUAL								
44	-ELECTRICAL								
45	-HYDRAULIC								
46	-PNEUMATIC								
47									
48	**CIRCUITRY						1.12		
49	SUPPORTS AND BRACKETS-WING								
50	-TAIL								
51	-BODY								
52	-NACELLE								
53									
54									
55	COLUMN TOTALS						1.12		
56	TOTAL-ANTI-ICING								1.12
57	TOTAL-AIR CONDITIONING AND ANTI-ICING GROUP - PG 37-38								34.27

* IF NOT SPECIFIED AS SPECIAL EQUIPMENT
 ** FROM MAIN DISTRIBUTION POINT TO ACTUATING UNIT.

AN 9102-D-TAB
 NAME
 DATE

AUXILIARY GEAR GROUP

PAGE 21
 MODEL
 REPORT 04B148

	HANDLING	ARREST	CATAPULT	ATO
1				
2				
3				
4	HANDLING GEAR			
5	ANCHOR			
6	ANCHOR LINE			
7	PENDANT & CLAMP FITTING			
8	LIZARD			
9	SHEAVES			
10	WINCH-COMLETE			
11	WINCH CRANK			
12	ANCHOR RIG OR DAVIT			
13	WINCH ENGINE OR MOTOR			
14				
15*	HOISTING SLING			
16	WING HANDLING LINES			
17	WATER RUDDER			
18	FITTINGS			
19	-RECOVERY HOOK			
20	-BEACH GEAR ATTACHMENT			
21	-TIEDOWN			
22	-JACKING	.49		
23	-TOWING			
24	-MOORING & SNUBBING			
25	-ANCHORAGE			
26	-LEVELING	.17		
27	-HOISTING			
28				
29	ARRESTING OR DECELER GEAR			
30	TRAILING HOOK			
31	HOOK POINT-TYPE			
32	EXTENSION GEAR			
33	RETRIEVING GEAR			
34	BUMPER			
35	SHOCK ABSORBER			
36	ATTACHMENT FITTINGS			
37	BARRIER CRASH FITTINGS			
38				
39	DECELERATION-PARACHUTE		13.60	
40	-CONTAINER & FITTINGS		5.37	
41	-CONTROLS		7.76	
42				
43	CATAPULTING GEAR			
44	CATAPULT FITTINGS			
45	CATAPULT HOOKS			
46	HOLD BACK FITTINGS			
47				
48	ASSISTED TAKE OFF			
49	HOOKS			
50	CONTROLS-FIRING			
51	-BOTTLE RELEASE			
52				
53	BOTTLE STOWAGE PROV			
54	QTY BOTTLES-			
55	COLUMN TOTALS	.66	26.73	
56	PAGE TOTAL			27.39
57	TOTAL-AUXILIARY GEAR GROUP			27.39

* IF NOT SPECIFIED AS SPECIAL EQUIPMENT.

RYAN

REPORT NO.
64B148

WEIGHT AND BALANCE REPORT
XV-5A

PAGE 93

2.4 Actual Weight and Center of Gravity

AN-92-49-A

Load Condition EMPTY

Prepared by M. Senio

Date 1 December 1964

Page 95

Model XV-5A

Report No. 64B148

AIRCRAFT ACTUAL WEIGHT AND HORIZONTAL BALANCE

Contract No. DA44-177-TC-715, Gov't. No. 62-4506, Fact. No. 2, Art. No. 2

SCALE POSITION	SCALE NO.	SCALE READING (Lbs.)	TARE	SCALE ERROR	SYMBOL	NET WEIGHT
Left Main Wheel		3260	12			3248
Right Main Wheel		3320	10			3310
Nose Wheel		2140	12			2128
TOTAL WEIGHT		8720	34			8686

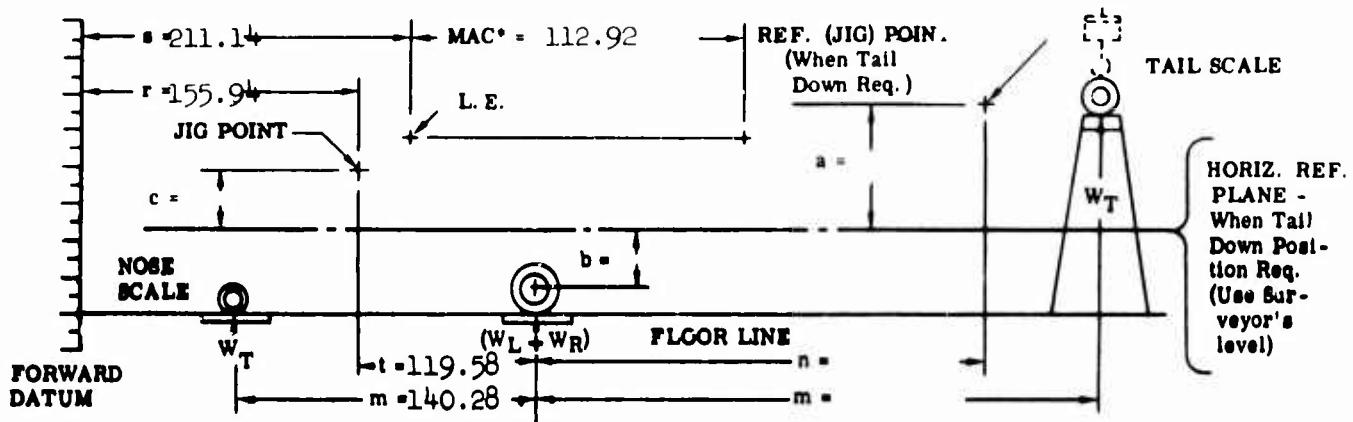

CENTER OF GRAVITY TO FORWARD DATUM (HORIZ. DIST. - AS WEIGHED)

Tail Wheel Type: $r + t + \frac{W_T \times m}{W} = \dots$ In.

Nose Wheel Type: $r + t - \frac{W_T \times m}{W} = 275.52 - \frac{2128 \times 140.28}{8686} = 241.15$ In.

CORRECTED WEIGHT & HORIZONTAL BALANCE

ITEMS ADDED & SUBTRACTED	WEIGHT (Lbs.)	H-DIST (In.) C.G. TO FWD. DATUM	MOMENT (In. - Lbs.)	GUARANTEED
Aircraft as Weighed	8686.00	241.15	2094629	
Plus - See Pages	122.47		53291	
Minus - See Pages	- 745.21		- 145333	
TOTAL EMPTY WEIGHT	8063	248.37	2002587	
BALANCE $\frac{(H-Dist.) - S}{M.A.C.}$	$\frac{248.37 - 211.14}{112.92}$	33.0	% M.A.C.	to % M.A.C.

*M.A.C. calc. in accord. with Handb'k Sec. II, Part II, (Army) or SR-7 (Navy)

RYAN

REPORT NO. 64B148	WEIGHT AND BALANCE REPORT XV-5A	PAGE 97
----------------------	------------------------------------	---------

ITEMS ON AIRPLANE THAT ARE NOT PART OF WEIGHT EMPTY:

	<u>WEIGHT</u>	<u>ARM</u>	<u>MOMENT</u>
143P085 Auxiliary Fuel Tank	35.17	339.0	11,922
Oil - Engine & Trapped	15.00	204.0	3,060
Ldg. Gear Steel Fairing Vs Doors	68.00	313.5	21,318
Exterior Paint	33.00	278.0	9,108
Aircraft Damage Repair Disposition Dated 4-15-64	8.12	125.0	1,015
Repair of Pitch Fan Bellmouth and Vanes	4.33	62.0	268
Patches on Vert. & Horiz. Stabilizer Skins to Facilitate Modification	2.60	480.0	1,248
143P047 Gear Box Mount Repair	.19	195.0	37
The Following Material Review Requests			
No. 29538 Tail Skid Beef-up	.25	480.0	120
No. 29551 Repair Crack in F004-276	.10	110.0	11
No. 29558 Repair Crack in K004-1	.10	125.0	13
No. 29571 Repair P006-19 Flapper	.15	200.0	30
No. 36501 Fix P006 Fire Doors	.12	200.0	24
No. 36511 Repair Cracks in P034 Door	.30	80.0	24
No. 36593 Patch F016-25	.06	470.0	28
No. 36618 Repair Wing	1.50	240.0	360
No. 36641 Patch P010 Inlet	.50	59.0	30
No. 36644 Patch Skin Cracks	.06	260.0	16
No. 36682 Reinforce T/M Antenna Bracket	.40	160.0	64
Ballast for Vertical Gyro	6.00	115.0	690
Emergency Escape Axe	2.00	140.0	280
Auxiliary Oxygen System	19.00	147.0	2,793
Bracket & Battery -- Camera	22.30	130.0	2,899
Instrumentation	515.00	162.0	84,472
Parachute - 12.75 Ft. Dia.	10.90	500.0	5,450
TOTAL DEDUCTIONS	745.21		145,333

RYAN

REPORT NO. 64B148	WEIGHT AND BALANCE REPORT XV-5A	PAGE 99
----------------------	------------------------------------	---------

2.5 Weight Empty - Weight and Balance Summary

RYAN

REPORT NO. 64B148	WEIGHT AND BALANCE REPORT XV-5A	PAGE 101
----------------------	------------------------------------	----------

WEIGHT EMPTY - WEIGHT AND BALANCE SUMMARY

	WEIGHT	HORIZONTAL		VERTICAL	
		ARM	MOMENT	ARM	MOMENT
WING	1059.27	263.5	279151	104	109956
TAIL	267.07	493.9	131907	184	49141
BODY	1340.69	249.8	334885	109	145476
LANDING GEAR (Gear Up)	(481.85)	279.5	(134688)	91	(43650)
Main Gear	399.56	313.3	125184	93	37014
Nose Gear	82.29	115.5	9504	81	6636
SURFACE CONTROLS	440.20	233.0	102549	104	45827
ENGINE SECTION	44.55	250.0	11138	139	6174
PROPULSION	(3676.34)	234.7	(863513)	116	(425248)
Gas Generator Section	1257.92	242.0	304007	142	179504
Lift Fan Section	1905.74	255.8	487475	102	194100
Pitch Fan Section	337.18	91.9	31004	93	31492
Fuel System	124.39	240.5	29917	117	14561
Engine Controls	42.90	215.9	9261	109	4685
Starting System	8.21	225.2	1849	110	906
FIXED EQUIPMENT	(698.33)		(140226)		(81218)
Instruments	73.00	163.2	11950	120	8776
Hydraulics & Pneumatics	115.43	183.3	21153	123	14158
Electrical	195.57	253.4	49552	117	22962
Radio	39.64	153.3	6075	95	3763
Furnishings & Equipment	212.95	152.0	32641	112	23953
Air Conditioning & Anti-Icing	34.27	192.6	0002	137	4690
Auxiliary Gear	27.39	448.1	12273	106	2916
UNACCOUNTABLE WEIGHT	54.70		4530		4429
TOTAL WEIGHT EMPTY (Gear Up)	8063.00	248.4	2002587	113	911119

RYAN

REPORT NO. 64B148	WEIGHT AND BALANCE REPORT XV-5A	PAGE 103
----------------------	------------------------------------	----------

2.6 Weight Empty - Weight and Balance Details

RYAN

REPORT NO. 64B148	WEIGHT AND BALANCE REPORT W-5A	PAGE 105
----------------------	-----------------------------------	----------

WEIGHT EMPTY - WEIGHT AND BALANCE DETAILS

	WEIGHT	HORIZONTAL		VERTICAL	
		ARM	MOMENT	ARM	MOMENT
WING GROUP	(1059.27)	263.5	(279151)	104	(109956)
Basic Structure	(567.20)	255.7	(145032)	102	(57624)
Center Section	(423.12)	250.2	(105879)	101	(42744)
Upper Skin and Supports	(31.28)	254.9	(7973)	105	(3298)
Interspar Skin	17.29	251.9	4356	107	1850
Skin Joints, Splices, etc.	8.81	259.6	2287	102	903
Brackets - Skin Support	5.18	256.7	1330	105	545
Lower Skin and Supports	(36.41)	256.6	(9343)	96	(3492)
Interspar Skin	25.07	257.5	6456	95	2393
Skin Joints, Splices, etc.	4.44	252.9	1123	96	428
Brackets - Skin Support	6.90	255.7	1764	97	671
Front Spar	94.34	217.0	20473	101	9528
Rear Spar	88.50	296.5	26240	101	8339
Ribs - Interspar	4.42	263.3	1164	100	442
Bulkhead @ B.L. 100.75	23.09	261.6	6041	102	2351
Joints, Splices and Fasteners	5.83	260.0	1516	99	577
Fan Ring	25.95	258.1	6697	101	2624
Leading Edge	(63.37)	208.6	(13220)	101	(6407)
Skin	36.00	207.2	7460	101	3643
Ribs	22.09	209.4	4626	101	2331
Joints, Splices & Fasteners	5.28	214.8	1134	101	333
Trailing Edge	(23.60)	303.9	(7172)	103	(2435)
Skin	16.95	304.6	5163	103	1754
Ribs	3.75	300.2	1126	102	383
Auxiliary Spar	1.58	306.0	483	103	163
Joints, Splices & Fasteners	1.32	303.4	400	103	135
Attach Fittings - Wing to Body	26.33	229.4	6040	101	2650
Outer Panel	(144.08)	271.7	(39153)	103	(14879)
Skin	56.04	272.0	15243	104	5811
Front Spar	14.79	252.5	3734	103	1524
Rear Spar	13.55	296.5	4018	103	1401
Doublers - Skin	3.90	288.6	1126	99	386
Ribs	29.82	271.5	8096	103	3067
Joints, Splices & Fasteners	1.77	293.2	519	102	181

WEIGHT EMPTY - WEIGHT AND BALANCE DETAILS (Cont'd.)

	WEIGHT	HORIZONTAL		VERTICAL	
		ARM	MOMENT	ARM	MOMENT
WING GROUP (Cont'd.)					
Basic Structure (Cont'd.)					
Outer Panel (Cont'd.)					
Leading Edge	(14.48)	245.5	(3555)	103	(1497)
Skin	10.80	245.7	2653	103	1117
Ribs	2.48	248.1	615	104	257
Joints, Splices & Fasteners	1.20	238.9	287	103	123
Trailing Edge	(5.69)	299.6	(1704)	103	(588)
Skin	3.48	299.6	1043	103	357
Stiffeners	.71	301.5	214	106	75
Ribs	1.27	298.7	379	104	132
Joints, Splices & Fasteners	.15	298.9	45	99	15
Tips	4.12	286.7	1181	105	433
Secondary Structure	(353.84)	258.3	(91397)	108	(38338)
Doors, Panels & Miscellaneous	(353.84)	258.3	(91397)	108	(38338)
Access Doors	15.88	273.7	4346	100	1584
Fan Doors	(259.57)		(66541)		(28552)
Fan Door Structure	126.56	256.0	32401	110	13932
Hinges and Supports	27.16	255.9	6951	112	3053
Power Transmission	17.47	272.5	4760	105	1838
Actuator	27.36	256.0	7004	109	2982
Actuator - Support	41.05	256.0	10508	112	4594
Lock Mechanism	19.97	246.2	4917	108	2153
Fan Seal	16.30	245.6	4149	104	1697
Seal-Trailing Edge-Flap	1.64	311.1	510	103	169
Insulation - External	29.59	269.4	7972	104	3144
Fairings and Fillets	30.86	255.3	7879	103	3192
Control Surfaces	(138.23)	309.1	(42722)	101	(13994)
Ailerons	(61.69)	306.5	(18908)	103	(6361)
Spars	5.60	305.5	1711	103	576
Ribs	8.81	307.4	2708	103	910
Skin and Stiffeners	9.77	307.1	3001	104	1015
Trailing Edge Strip	.42	320.4	135	105	44
Tips	1.80	306.5	552	106	191
Tabs	(11.69)	318.6	(3725)	102	(1188)
Tab Structure	8.11	319.4	2590	102	826
Balance Weights	5.00	317.2	1586	101	50

WEIGHT EMPTY - WEIGHT AND BALANCE DETAILS (Cont'd.)

	WEIGHT	HORIZONTAL		VERTICAL	
		ARM	MOMENT	ARM	MOMENT
WING GROUP (Cont'd.)					
Control Surfaces (Cont'd.)					
Ailerons (Cont'd.)					
Aerodynamic Seals	1.66	298.0	495	104	173
Access Doors	.69	310.0	214	105	72
Hinges and Pins	1.38	306.8	423	103	142
Control Surface Supports	(18.45)	297.8	(5495)	103	(1906)
Hinges	14.12	299.2	4224	103	1461
Brackets	4.33	293.4	1271	103	445
Flaps	(76.54)	311.1	(23814)	100	(7633)
Spars	8.95	310.0	2774	100	695
Stringers	1.48	317.1	469	100	149
Ribs	14.00	311.2	4356	100	1403
Skin & Stiffeners	34.35	312.9	10747	100	3435
Trailing Edge Strip	1.80	324.0	583	100	180
Actuator Attach Structure	2.10	308.7	765	100	248
Hinges and Pins	7.23	307.8	2226	100	720
Control Surface Supports	(6.25)	303.0	(1894)	96	(603)
Hinges	4.65	301.5	1462	97	471
Brackets	1.40	308.7	432	94	132
TAIL GROUP	(267.07)	493.9	(131907)	184	(49141)
Horizontal Stabilizer					
(107.63)					
Skin	20.64	504.4	10412	206	4251
Front Spar	2.73	483.1	1319	206	562
Center Spar	8.43	496.0	4181	206	1737
Rear Spar	3.44	513.7	1767	203	697
Ribs	15.10	502.3	7592	206	3109
Joints, Splices & Fasteners	2.15	497.1	1069	206	443
Leading Edge	(8.72)	485.5	(4234)	206	(1796)
Skin	6.24	485.0	3027	206	1285
Ribs	2.48	486.5	1207	206	511
Trailing Edge	(.71)	521.1	(370)	206	(146)
Stiffeners	.05	533.1	27	206	10
Ribs	.66	519.2	343	206	136
Fibreglass Fairing	35.90	483.2	17348	196	7025
Tips	4.26	510.6	2175	206	878
Actuator Fitting	.29	483.8	140	205	59
Pivot Fitting	1.39	496.1	690	204	283
Aerodynamic Seal Attachment	.91	513.7	467	206	187
Exterior Finish	2.96	493.7	1461	206	610

REPORT NO.
64B148

WEIGHT AND BALANCE REPORT
XV-5A

PAGE 108

WEIGHT EMPTY - WEIGHT AND BALANCE DETAILS (Cont'd.)

	WEIGHT	HORIZONTAL		VERTICAL	
		ARM	MOMENT	ARM	MOMENT
TAIL GROUP (Cont'd.)					
Vertical Stabilizer	(83.76)	480.7	(40310)	167	(13978)
Skin	25.76	484.6	12484	165	4250
Front Spar	4.65	458.7	2133	161	750
Center Spar	10.23	478.6	4896	163	1669
Rear Spar	3.01	498.6	1501	151	455
Ribs	20.71	483.1	10006	167	3455
Leading Edge	(7.66)	453.7	(3475)	164	(1260)
Skin	4.67	452.6	2114	165	771
Ribs	2.99	455.2	1361	163	489
Trailing Edge	(.96)	505.2	(485)	160	(154)
Stiffeners	.68	502.1	341	154	104
Ribs	.28	513.9	144	180	50
Fibreglass Fairing	2.77	514.1	1424	190	527
Actuator Fitting	.42	474.9	199	186	78
Pivot Fitting	2.59	495.8	1284	200	518
Access Doors	2.60	488.6	1270	185	480
Aerodynamic Seal Attachment	.41	500.0	205	155	64
Exterior Finish	1.99	476.5	948	160	318
Dorsal Fin	(3.15)	421.7	(1328)	145	(458)
Skin	1.54	420.0	647	145	223
Joints, Splices & Fasteners	.63	419.3	264	148	93
Frames	.88	426.6	375	145	128
Exterior Finish	.10	420.0	42	145	14
Elevator	(40.10)	517.9	(20768)	206	(8262)
Spars	2.14	518.2	1109	206	441
Ribs	2.44	521.8	1273	206	503
Skin	8.70	522.4	4545	206	1792
Trailing Edge Strip	.60	530.5	318	206	124
Torque Tube	3.15	517.8	1631	206	649
Balance Weights & Supports	17.56	515.0	9044	206	3617
Aerodynamic Seal	1.23	515.0	633	206	253
Access Doors	.38	517.7	197	206	79
Hinges and Pins	1.78	517.8	922	206	367
Control Surface Support Hinges	2.12	517.1	1096	206	437

REPORT NO.
64B148

WEIGHT AND BALANCE REPORT
XV-5A

PAGE 109

WEIGHT EMPTY - WEIGHT AND BALANCE DETAILS (Cont'd.)

	WEIGHT	HORIZONTAL		VERTICAL	
		ARM	MOMENT	ARM	MOMENT
TAIL GROUP (Cont'd.)					
Rudder	(32.43)	501.9	(16276)	144	(4660)
Spars	4.55	504.3	2295	149	678
Ribs	1.83	507.0	928	146	267
Rib Attach Angles	.11	507.0	56	138	15
Skin	4.02	507.7	2041	151	607
Trailing Edge Strip	.24	520.8	25	161	39
Tab	1.88	512.3	963	131	247
Torque Tube	3.48	496.2	1727	122	424
Balance Weights & Supports	12.21	498.0	6081	148	1803
Aerodynamic Seal	.84	500.1	420	154	129
Access Doors	.53	505.4	268	130	69
Hinges and Pins	.96	512.0	492	168	162
Control Surface Supports	(1.78)	494.4	(880)	124	(220)
Hinges	.69	495.3	342	120	83
Brackets	.77	492.3	379	122	94
Actuator	.32	496.6	159	134	43
BODY GROUP	(1340.69)	249.8	(334885)	109	(145476)
Basic Structure	(798.91)	257.0	(205307)	110	(88044)
Bulkhead and Frames	(325.09)	254.4	(82716)	110	(35872)
Front Hinge Frame	3.92	35.2	138	93	364
Rear Hinge Frame	12.40	80.3	996	83	1031
Frame - Sta. 91	12.49	90.3	1128	97	1216
Bulkhead - Sta. 214	47.13	214.1	10090	106	4993
Canted Bulkhead - Sta. 146	27.76	148.5	4121	108	3002
Bulkhead - Sta. 165.2	14.46	165.0	2386	106	1530
Frame, Engine Support - Sta. 214	13.63	210.4	2867	150	2049
Bulkhead - M.L.G. Drag Strut	20.25	317.0	6419	112	2277
Bulkhead - M.L.G. - Sta. 287	20.06	287.0	5757	125	2502
Bulkhead - Rear Spar - Sta. 296	39.49	296.5	11709	104	4114
Bulkhead - Stab. Front Spar	5.12	432.8	2216	119	608
Bulkhead - Stab. Center Spar	6.30	436.6	2876	116	732
Bulkhead - Stab. Rear Spar	3.44	488.4	1680	120	413
Minor Frames	98.64	307.5	30333	112	11041

RYAN

REPORT NO.
64B148

WEIGHT AND BALANCE REPORT XV-5A

PAGE 110

WEIGHT EMPTY - WEIGHT AND BALANCE DETAILS (Cont'd.)

	WEIGHT	HORIZONTAL		VERTICAL	
		ARM	MOMENT	ARM	MOMENT
BODY GROUP (Cont'd.)					
Basic Structure (Cont'd.)					
Truss Structure	114.03	252.6	28802	114	12999
Joints, Splices & Fasteners	19.51	293.4	5724	110	2151
Vertical Stiffeners	2.55	131.2	334	106	271
Skin - Upper Between Longerons	25.33	348.7	8831	143	3615
Skin - Side Between Longerons	50.31	299.3	15057	112	5637
Skin - Lower Between Longerons	21.43	335.0	7179	94	2004
Horizontal Stiffeners	4.51	215.8	973	111	500
Stringers - Side	6.99	186.4	1303	112	783
Wing L.E. Attach Fittings	.78	189.0	147	100	78
Drag Angle - Fuselage to Fin	4.99	440.0	2196	135	674
Longerons - Upper	36.55	264.0	9648	127	4626
Longerons - Lower	40.43	277.4	11217	98	3967
Longerons - Upper External	8.04	349.1	2807	152	1221
Horizontal Shear Webs	65.05	239.1	15551	107	6974
Flooring and Supports	21.21	158.6	3363	94	1984
Nose Wheel Well	12.89	117.4	1513	82	1054
Main Gear - Door Support Structure	21.18	309.4	6554	89	1887
- Pitch Fan Mount Structure	15.63	67.8	1059	98	1527
Pitch Fan Cutout Keelson	1.32	57.9	76	77	102
Miscellaneous	1.09	235.6	257	108	118
Secondary Structure	(157.65)	141.3	(22277)	122	(19184)
Enclosure	(68.16)	132.7	(9045)	131	(8938)
Canopy	63.13	131.1	8273	131	8256
Canopy Hinge Structure	4.25	160.4	682	141	598
Canopy Latch Structure	.78	115.7	90	108	84
Windshield	53.94	104.5	5636	122	6607
Heat Shielding - Internal	8.85	170.7	1511	107	949
Jack Pad Provisions	1.07	394.0	422	97	104
Nose Cone	14.85	17.9	265	94	1394
Tail Cone	9.16	500.7	4586	112	1026
Tail Bumper	1.62	501.0	812	102	166
Doors, Panels & Miscellaneous	(384.13)	279.3	(107301)	100	(38248)
Nose Ldg. Gear Door	(11.31)	114.2	(1292)	77	(875)
Door Structure	7.31	117.8	861	75	551
Door Mechanism	4.00	107.9	431	81	324

RYAN

REPORT NO.
64B148

WEIGHT AND BALANCE REPORT XV-5A

PAGE 111

WEIGHT EMPTY - WEIGHT AND BALANCE DETAILS (Cont'd.)

	WEIGHT	HORIZONTAL		VERTICAL	
		ARM	MOMENT	ARM	MOMENT
BODY GROUP (Cont'd.)					
Doors, Panels & Miscellaneous(Cont'd.)					
Main Ldg. Gear Door	(111.91)	310.2	(34714)	84	(9414)
Door Structure	66.46	310.1	20610	82	5437
Mechanism and Controls	5.89	317.0	1867	85	504
Power Transmission	3.71	326.2	1210	90	335
Actuator	35.85	307.6	11027	88	3138
Access Doors - Miscellaneous	29.97	247.5	7418	91	2737
Access Door - Spin Chute	2.31	470.2	1086	113	262
Access Door - Sta. 100 to 133	7.36	116.2	855	79	582
Access Door - Elect. Compt.	7.02	155.6	1092	100	702
Panels	(147.68)	237.6	(35087)	115	(16966)
Access - Top - Sta. 214-287	47.54	248.7	11824	151	7191
Access - Side - Sta. 214-287	36.30	249.3	9051	121	4385
Access - Lower - Sta. 165-276	52.88	222.4	11760	82	4311
Seal - Fuselage to Canoe	2.65	285.0	755	94	250
Closure - Pitch Fan	2.81	63.8	179	96	270
M.L.G. Well Protective	3.39	308.1	1044	102	346
Cover - Mechanical Mixer	2.11	224.7	474	101	213
Fairing - Tail Pipe Exit	19.88	417.4	8298	95	1894
Exterior Finish	5.59	311.3	1740	110	617
Insulation - External	28.40	354.5	10068	101	2882
Exhaust Deflector Plate	12.70	445.0	5651	103	1314
ALIGHTING GEAR GROUP (Retracted Position)	(481.85)	279.5	(134688)	91	43650
Main Gear	(399.56)	313.3	(125184)	93	(37014)
Running Gear	(80.98)	352.7	(28562)	92	(7450)
Wheels, 20 x 4.4 (2)	28.90	352.7	10193	92	2659
Tires, 20 x 4.4, 12 Ply, Type VII	23.70	352.7	8359	92	2180
Brakes	28.38	352.7	10010	92	2611
Structure	(258.23)	315.6	(81485)	92	(23789)
Drag Strut	36.83	308.1	11349	88	3247
Side Strut	10.10	312.6	3157	87	879
Vee Brace	15.09	287.7	4342	86	1304
Shock Strut	79.14	327.9	25946	92	7285

REPORT NO.
64B148

WEIGHT AND BALANCE REPORT
XV-5A

PAGE 112

WEIGHT EMPTY - WEIGHT AND BALANCE DETAILS (Cont'd.)

	WEIGHT	HORIZONTAL		VERTICAL	
		ARM	MOMENT	ARM	MOMENT
ALIGHTING GEAR GROUP (Cont'd.)					
(Retracted Position)					
Main Gear (Cont'd.)					
Structure (Cont'd.)					
Insulation - Struts	31.23	310.8	9707	86	2674
Oil - Shock Strut	3.40	332.1	1129	92	313
Torque Arms	5.66	343.3	1943	88	498
Two-Position Linkage	29.43	311.3	916.1	98	2877
Main Attach Fittings - Body	45.58	311.6	14203	100	4545
Ground Feeler Probe	.62	352.7	219	92	57
Pins, Bolts, Nuts, Etc.	1.15	286.0	329	96	110
Controls	(60.35)	250.8	(15137)	96	(5775)
Retracting	(33.15)	270.0	(8952)	96	(3192)
Electrical Circuitry	4.13	236.2	975	100	413
Electrical Controls	1.04	110.1	115	114	119
Hydraulic Operating Mech.	(13.11)	304.0	(3986)	92	(1207)
Plumbing	3.97	305.3	1212	95	377
Selector Valves	1.36	232.0	397	94	128
Sequence Valves	.68	305.0	207	93	63
Actuator	7.06	305.7	2158	90	635
Fluid	.04	296.0	12	98	4
Uplatch Operating Mech.	(9.60)	328.6	(3155)	94	(903)
Actuator	.97	329.0	319	91	88
Mechanism	8.63	328.7	2836	94	815
Position Indicating Mech.	5.10	131.5	670	105	534
Supports - Body	.17	298.2	51	96	16
Brake Operating	(10.78)	159.2	(1716)	103	(1115)
Mechanical Controls	2.40	98.2	236	106	255
Hydraulic Plumbing	6.84	191.8	1312	101	691
Supports - Body	1.30	95.1	124	113	147
Hydraulic Fluid	.24	185.0	44	90	22
Emergency Extension	(5.84)	217.5	(1270)	93	(543)
Electrical Circuitry	.24	127.7	31	94	23
Pneumatic Operating Mech.	(5.15)	229.1	(1180)	93	(480)
Controls	1.65	128.1	211	95	157
Plumbing	3.50	276.7	969	92	323

RYAN

REPORT NO.
64B148

WEIGHT AND BALANCE REPORT XV-5A

PAGE 113

WEIGHT EMPTY - WEIGHT AND BALANCE DETAILS (Cont'd.)

	WEIGHT	HORIZONTAL		VERTICAL	
		ARM	MOMENT	ARM	MOMENT
ALIGHTING GEAR GROUP (Cont'd.) (Retracted Position)					
Main Gear (Cont'd.)					
Controls (Cont'd.)					
Emergency Extension (Cont'd.)					
Supports - Body	.45	131.4	59	88	40
Two Positioning Controls	(10.58)	302.4	(3199)	87	(925)
Electrical Circuitry	1.13	222.7	252	98	111
Plumbing	.48	319.0	153	87	42
Selector Valve	1.34	322.0	431	91	122
Actuator	7.40	309.4	2290	85	629
Supports - Body	.15	323.0	48	93	14
Hydraulic Fluid	.08	316.0	25	84	7
Nose Gear	(82.29)	115.5	(9504)	81	(6636)
Running Gear	(20.17)	99.2	(2001)	83	(1674)
Wheel (1)	9.22	99.2	915	83	765
Tire, 18 x 4.4	10.95	99.2	1086	83	909
Structure	(55.31)	120.5	(6665)	79	(4371)
Shock Strut, Oil & Damper	44.23	120.3	5321	78	3450
Drag Strut	7.14	120.9	863	86	612
Main Attach Fittings - Body	3.94	122.1	481	78	309
Controls	(6.81)	123.0	(838)	87	(591)
Retracting	(6.27)	123.6	(775)	87	(543)
Electrical Circuitry	.77	130.6	101	87	67
Hydraulic Operating Mech.	(5.09)	122.6	(624)	86	(437)
Plumbing	2.81	121.4	341	84	237
Fluid	.10	125.0	12	85	8
Actuator	2.18	124.1	271	88	192
Position Indicating Mech.	.32	122.8	39	97	31
Supports - Body	.09	121.7	11	86	8
Emergency Extension	(.54)	116.7	(63)	89	(48)

RYAN

REPORT NO.
64B148

WEIGHT AND BALANCE REPORT XV-5A

PAGE 114

WEIGHT EMPTY - WEIGHT AND BALANCE DETAILS (Cont'd.)

	WEIGHT	HORIZONTAL		VERTICAL	
		ARM	MOMENT	ARM	MOMENT
ALIGHTING GEAR GROUP (Cont'd.)					
(Retracted Position)					
Nose Gear (Cont'd.)					
Controls (Cont'd.)					
Emergency Extension (Cont'd.)					
Electrical Circuitry	.26	116.4	30	94	24
Pneumatic Plumbing	.28	117.0	33	86	24
SURFACE CONTROLS	(440.20)	233.0	(102549)	104	(45827)
Cockpit Controls					
Cockpit Controls	(24.45)	117.5	(2872)	101	(2462)
Control Column	3.67	117.7	432	109	399
Control Column Conn. Members	6.79	123.6	839	88	600
Rudder Pedals	6.44	101.8	656	108	697
Rudder Pedal Supports	.57	118.2	67	96	55
Rudder Pedal Adjust Mech.	1.35	101.2	137	108	146
Lift Stick	5.25	130.7	686	101	530
Lift Stick Mechanism	.38	144.0	55	92	35
Auto-Stabilization					
Auto Stabilization Controller	29.79	149.5	4455	101	3008
Electrical Circuitry	10.93	172.6	1886	99	1080
System Controls - Conventional					
System Controls - Conventional	(137.15)	318.0	(43614)	118	(16148)
Aileron					
Aileron	(41.31)	248.8	(10279)	99	(4105)
Mechanical Controls					
Mechanical Controls	(18.88)	228.1	4306	99	1867
Electrical Circuitry	.40	252.6	101	102	41
Trim Controls	1.58	307.8	486	104	164
Hydraulic Operating Mech.					
Hydraulic Operating Mech.	(12.06)	298.5	(3600)	99	(1197)
Plumbing	5.37	300.0	1611	98	528
Fluid	.39	300.0	117	99	39
Actuators	6.30	297.2	1872	100	630
Aileron Droop System					
Aileron Droop System	(4.93)	192.1	(947)	100	(494)
Mechanical Controls	3.37	193.5	652	100	336
Electric Actuator	1.24	198.0	246	101	125
Electric Circuitry	.32	154.1	49	104	33
Supports - Wing					
Supports - Wing	2.73	255.7	698	100	272
Supports - Body					
Supports - Body	.73	193.3	141	96	70

RYAN

REPORT NO.
64B148

WEIGHT AND BALANCE REPORT XV-5A

PAGE 115

WEIGHT EMPTY - WEIGHT AND BALANCE DETAILS (Cont'd.)

	WEIGHT	HORIZONTAL		VERTICAL	
		ARM	MOMENT	ARM	MOMENT
SURFACE CONTROLS (Cont'd.)					
System Controls-Conventional (Cont'd.)					
Elevator	(21.13)	294.5	(6222)	119	(2512)
Mechanical Controls	12.86	352.6	4534	135	1737
Tension Regulator	4.20	159.2	669	86	361
Supports - Body	4.07	250.4	1019	102	414
Rudder	(19.54)	302.4	(5908)	106	(2068)
Mechanical Controls	10.16	204.9	2082	98	991
Tension Regulator	4.12	494.9	2039	117	482
Electrical Circuitry	.75	264.5	198	120	90
Trim Controls	1.57	470.4	739	127	200
Supports - Body	2.94	289.3	850	104	305
Flaps	(15.70)	311.1	(4883)	100	(1577)
Electrical Circuitry	2.81	259.9	730	103	290
Electric Actuator	11.72	321.5	3768	100	1172
Supports - Body	1.17	329.3	385	99	115
Horizontal Stabilizer	(39.47)	413.5	(16322)	149	(5886)
Electrical Circuitry	6.21	278.1	1727	116	723
Trim Controls - Electrical	1.75	359.6	629	90	158
Hydraulic Actuating Mech.	(31.51)	443.2	(13966)	159	(5005)
Plumbing	14.89	410.5	6113	125	1858
Fluid	1.63	404.7	660	121	197
Actuator	14.47	480.9	6959	198	2864
Supports - Tail	.40	471.4	189	187	75
Supports - Body	.12	374.5	45	89	11
System Controls - VTOL	(237.88)	209.0	(49722)	97	(23129)
Pitch System	(38.24)	114.3	(4372)	91	(3476)
Mechanical Controls	13.41	149.6	2005	87	1171
Electrical Operating Mech.	(5.14)	95.3	(490)	103	(528)
Controls	3.70	59.0	218	104	385
Circuitry	.63	146.0	92	98	62
Trim Controls	.81	222.0	180	100	81

WEIGHT EMPTY - WEIGHT AND BALANCE DETAILS (Cont'd.)

	WEIGHT	HORIZONTAL		VERTICAL	
		ARM	MOMENT	ARM	MOMENT
SURFACE CONTROLS (Cont'd.)					
System Controls - VTOL (Cont'd.)					
Pitch System (Cont'd.)					
Hydraulic Operating Mech.	(19.69)	95.3	(1877)	90	(1777)
Plumbing	5.91	111.3	657	95	561
Fluid	.81	111.7	90	93	75
Actuators	9.60	88.0	845	87	835
Supports - Body	3.37	84.7	285	91	306
Yaw System	(2.55)	197.3	(504)	99	(252)
Mechanical Controls	1.26	190.3	240	97	122
Electrical Circuitry	.32	162.1	52	104	33
Trim Controls - Elect.	.97	218.1	212	100	97
Roll System	(1.52)	213.2	(324)	100	(153)
Mechanical Controls	.40	206.0	82	99	40
Electrical Circuitry	.26	167.6	44	100	26
Trim Controls - Electrical	.86	230.3	198	101	87
Lift System	(110.62)	248.2	(27451)	97	(10683)
Mechanical Controls	13.38	227.4	3042	96	1289
Electrical Circuitry	.58	166.5	97	99	58
Thrust Vector Actuator	2.74	220.5	604	100	274
Hydraulic Operating Mech.	(93.92)	252.4	(23708)	96	(9062)
Plumbing	8.36	224.6	1877	99	830
Fluid	.87	207.1	180	99	87
Servo Actuator	53.56	257.3	13780	97	5195
Supports - Wing	31.05	252.9	7854	95	2942
Supports - Body	.08	216.2	17	97	8
Common To All Systems	(84.95)	201.0	(17071)	101	(8565)
Mechanical Mixer	34.54	227.7	7865	100	3446
Electrical Circuitry	8.20	170.5	1398	106	871
Circuitry Interlock	14.68	241.7	3548	112	1640
Electrical Mixer	27.09	154.8	4192	95	2568
Supports - Body	.44	155.4	68	91	40

RYAN

REPORT NO. 64B148	WEIGHT AND BALANCE REPORT XV-5A	PAGE 117
----------------------	------------------------------------	----------

WEIGHT EMPTY - WEIGHT AND BALANCE DETAILS (Cont'd.)

ENGINE SECTION	WEIGHT	HORIZONTAL		VERTICAL	
		ARM	MOMENT	ARM	MOMENT
	(44.55)	250.0	(11138)	139	(6174)
Engine Mounts	14.34	251.6	3608	140	2007
Firewall	30.21	249.3	7530	138	4167
PROPULSION GROUP	(3676.34)	234.7	(863513)	116	(425248)
Main Propulsion - Gas Generator	(1257.92)	242.0	(304007)	142	(179504)
Engine - G.E. J85-GE-5B (2)	935.90	225.0	210577	147	137577
Accessory Gear Box & Drive	(28.24)	195.8	(5528)	137	(3864)
Gear Box	19.60	192.4	3770	137	2680
Flex Shaft - Accessory Drive	8.64	203.5	1758	137	1184
Air Induction System	(63.01)	187.6	(11820)	147	(9247)
Air Intake Duct	60.08	186.5	11202	147	8805
Compressor Bleed Duct	2.93	211.1	618	151	442
Exhaust System	(220.47)	333.9	(73619)	124	(27271)
Tailpipe	148.93	322.6	48049	128	19102
Tailpipe Shroud & Insulation	58.23	344.3	20047	119	6930
Supports	.30	287.0	86	134	40
Thrust Spoiler Doors	7.57	418.1	3165	92	696
Thrust Spoiler Linkage	5.44	417.6	2272	92	503
Cooling System	(10.30)	239.1	(2463)	150	(1545)
Ejector	10.30	239.1	2463	150	1545
Main Propulsion - Lift Fan	(1905.74)	255.8	(487475)	102	(194100)
Lift Fan - G.E. X353-5B (2)	1765.74	256.0	452029	101	178339
Fan Mounts	8.06	244.8	1973	104	838
Air Induction System	(131.94)	253.7	(33473)	113	(14923)
Crossover Ducting	100.28	253.5	25423	112	11194
Duct Insulation	16.63	256.0	4257	120	1996
Duct Supports	15.03	252.3	3793	115	1733
Auxiliary Propulsion - Pitch Fan	(337.18)	91.9	(31004)	93	(31492)
Pitch Fan - G.E. X376 (1)	114.15	61.2	6986	100	11415
Fan Mounts	2.27	79.1	179	101	229

RYAN

REPORT NO. 64B148	WEIGHT AND BALANCE REPORT XV-5A	PAGE 118
----------------------	------------------------------------	----------

WEIGHT EMPTY - WEIGHT AND BALANCE DETAILS (Cont'd.)

PROPULSION GROUP (Cont'd.)	WEIGHT	HORIZONTAL		VERTICAL	
		ARM	MOMENT	ARM	MOMENT
Auxiliary Propulsion-Pitch Fan (Cont'd.)					
Air Induction System	(136.39)	138.1	(13842)	93	(12731)
Air Ducts	61.54	168.0	10340	86	5320
Duct Supports	5.74	171.1	982	89	514
Duct Shrouding	30.12	167.5	5046	85	2558
Intake Bellmouth	20.40	62.1	1266	111	2260
Intake Louvres	18.59	65.0	1208	112	2079
Exhaust System	(84.37)	59.2	(4997)	84	(7117)
Pitch Thrust Reverser	75.57	56.3	4252	84	6373
Thrust Reverser Linkage	8.80	84.7	745	85	744
Lubricating & Fuel System	(124.39)	240.5	(29917)	117	(14561)
Main Fuel System	(122.20)	240.6	(29406)	117	(14307)
Forward Tank (246 gal.)	18.88	187.4	3539	112	2114
Aft Tank (126 gal.)	34.54	297.7	10284	118	4091
Backing Board - Fwd. Tank	8.85	188.7	1670	111	982
Tank Supports	2.80	299.4	838	113	316
Boost Pumps & Elect. Controls	14.22	220.6	5137	110	1563
Ground Filling System	4.33	214.8	930	130	564
Engine Drain System	10.10	219.8	2219	109	1101
Distribution System	20.59	219.6	4522	123	2537
Vent System	5.85	323.2	1891	138	808
Low Pressure Warning System	1.84	191.7	353	114	209
Fuel Valve Position Indicator	.20	113.0	23	110	22
Auxiliary Fuel System	(2.19)	233.2	(511)	116	(254)
Tank Supports	2.19	233.2	511	116	254
Oil System - Integral With Engine					
Engine Controls	(42.90)	215.9	(9261)	109	(4685)
Ignition	.68	157.8	107	117	80
Throttle	19.74	145.8	2877	106	2102
Diverter Valve	13.91	216.9	3017	125	1738
Thrust Spoiler	8.57	380.4	3260	89	765
Starting System - Air Impingement	8.21	225.2	1849	110	906

RYAN

REPORT NO.
64B148

WEIGHT AND BALANCE REPORT XV-5A

PAGE 119

WEIGHT EMPTY - WEIGHT AND BALANCE DETAILS (Cont'd.)

	WEIGHT	HORIZONTAL		VERTICAL	
		ARM	MOMENT	ARM	MOMENT
INSTRUMENTS	(73.08)	163.2	(11930)	120	(8776)
Accelerometer	.66	106.0	70	121	80
Machmeter	(2.04)	115.7	(236)	121	(247)
Indicator	1.65	105.2	174	124	204
Wiring	.39	158.4	62	111	43
Altimeter	1.31	105.0	138	124	162
Attitude	(3.07)	106.2	(326)	121	(370)
Indicator	2.86	106.0	303	121	346
Wiring	.21	110.5	23	115	24
Airspeed - Low Speed	.60	105.0	63	124	74
Rate of Climb Indicator	1.46	105.0	153	123	180
Landing Gear Warning Indicator	.05	110.0	5	116	6
Turn and Bank	(1.31)	109.2	(143)	115	(150)
Indicator	1.20	109.0	131	115	138
Wiring	.11	111.9	12	112	12
Flap - Thrust Spoiler Position	(2.31)	217.7	(503)	108	(249)
Indicator	.57	107.5	61	120	68
Transmitter	.10	410.0	41	100	10
Wiring	1.64	244.5	401	104	171
Standby Compass	(.93)	106.9	(99)	129	(120)
Indicator	.72	107.0	77	129	93
Installation	.21	104.5	22	129	27
Landing Gear Position	(1.75)	167.4	(293)	103	(180)
Indicator	.32	110.5	35	112	36
Wiring	1.43	180.6	258	101	144
Fuel Quantity	(7.97)	196.9	(1569)	119	(946)
Indicator	1.82	140.5	256	116	211
Transmitters	3.77	228.0	860	117	442
Wiring	2.38	190.5	453	123	293
Fuel Flow	(9.44)	175.1	(1653)	130	(1230)
Indicator	1.40	108.5	152	120	168
Transmitters	4.90	196.0	960	132	647
Wiring	3.14	172.3	541	132	415
Oil Pressure	(7.07)	198.3	(1402)	134	(950)
Indicator	.63	109.5	69	118	74
Transmitters	2.70	232.0	626	144	389
Wiring	3.74	189.0	707	130	487
Engine Tachometers (2)	(2.06)	137.9	(284)	129	(265)
Indicators	.98	108.3	106	124	122
Wiring	1.08	164.6	178	132	143
Hydraulic Pressure	(5.06)	145.8	(738)	127	(642)
Indicator	.87	120.4	105	123	107
Transmitter	3.00	156.5	470	131	393
Wiring	1.19	137.1	163	120	142
Pitot System	9.82	186.9	1836	103	1015
Clock	.43	109.5	47	115	49

RYAN

REPORT NO. 648148	WEIGHT AND BALANCE REPORT XV-5A	PAGE 120
----------------------	------------------------------------	----------

WEIGHT EMPTY - WEIGHT AND BALANCE DETAILS (Cont'd.)

	WEIGHT	HORIZONTAL		VERTICAL	
		ARM	MOMENT	ARM	MOMENT
INSTRUMENTS (Cont'd.)					
Alpha Meter - Angle of Attack	.63	108.5	68	118	74
Angle of Yaw	.63	108.5	68	118	74
Vector Angle	.26	107.0	28	120	31
Exhaust Temperature	(3.73)	153.1	(571)	123	(457)
Indicator - Dual	1.35	108.5	146	122	165
Wiring	2.38	178.7	425	123	292
Rudder, Aileron, Stab. Position	(4.13)	211.1	(872)	118	(488)
Indicator	1.11	108.5	120	115	128
Wiring	3.02	249.2	752	119	500
Louver Position	(1.27)	107.9	(137)	115	(147)
Indicator	1.11	108.5	120	115	128
Wiring	.16	109.0	17	118	19
Master Caution Panel	(2.90)	132.4	(384)	117	(338)
Indicator	.13	108.5	14	122	16
Panel	1.41	109.0	154	121	171
Wiring	1.36	158.5	216	111	151
Console Vibrator	.90	111.0	100	120	108
Attaching Hardware	.58	109.0	63	118	68
Switches, Etc.	.71	114.0	81	110	78
HYDRAULIC AND PNEUMATIC GROUP	(115.43)	183.3	(21153)	123	(14158)
Hydraulic Utility System	(113.47)	183.5	(20819)	123	(13982)
Pumps, Engine Driven (2)	14.32	174.8	2503	140	2005
Oil Coolers (2)	6.10	176.2	1075	135	823
Reservoirs (2)	14.30	165.1	2361	128	1830
Accumulators (2)	7.43	171.4	1274	127	944
Accumulator Charge Fittings	.80	171.2	137	129	103
Filters	6.64	168.0	1116	135	894
Pressure Switch	.74	159.9	118	128	95
Valves	(3.23)	171.8	(555)	128	(412)
Check	.16	177.7	28	140	22
Relief	2.92	171.5	501	127	371
Control	.15	171.4	26	127	19
Temperature Indication	.94	149.9	141	145	136
Low Pressure Warning	.38	143.4	54	123	47
Quick Disconnects	1.04	157.5	164	124	129
Plumbing	25.39	202.1	5131	114	2904
Fluid in System	25.62	203.1	5203	113	2898
Supports - Body	6.54	151.1	987	116	762
Pneumatic Emergency System	(1.96)	170.6	(334)	90	(176)
Plumbing	1.96	170.6	334	90	176

RYAN

REPORT NO. 64B148	WEIGHT AND BALANCE REPORT XV-5A	PAGE 121
----------------------	------------------------------------	----------

WEIGHT EMPTY - WEIGHT AND BALANCE DETAILS (Cont'd.)

	WEIGHT	HORIZONTAL		VERTICAL	
		ARM	MOMENT	ARM	MOMENT
ELECTRICAL GROUP	(195.57)	253.4	(49552)	117	(22962)
A.C. System	(5.82)	326.1	(1898)	109	(635)
Power Conversion	(.81)	146.5	(119)	102	(83)
Transformer	.81	146.5	119	102	83
Distribution & Controls	(3.90)	380.8	(1485)	112	(437)
Relays	2.28	458.1	1044	117	267
Wiring	.86	300.8	259	107	92
Conduit	.76	240.0	182	103	78
Lights & Signals	(1.11)	265.2	(294)	104	(115)
Wiring for Exterior Lights	1.11	265.2	294	104	115
D.C. System	(189.75)	251.1	(47654)	118	(22327)
Power Supply	(92.96)	243.5	(22634)	133	(12388)
Generators 165 AMP (2)	74.00	185.0	13690	139	10286
Battery (1)	18.00	471.7	8491	111	1998
Battery Supports	.96	471.8	453	109	104
Power Conversion	(28.44)	432.4	(12297)	110	(3119)
Static Inverter (2)	24.06	455.7	10964	110	2647
Wiring	4.38	304.3	1333	108	472
Distribution & Controls	(61.63)	183.6	(11313)	100	(6143)
Generator Controls	13.24	150.2	1988	93	1232
Volt-Ammeter	1.06	120.0	127	100	106
Switches, Rheostats & Panels	.27	120.0	32	100	27
Circuit Breaker & Fuses	10.06	132.3	1331	94	946
Junction Fuse & Dist. Boxes	2.23	152.0	339	96	213
Receptacles & Connectors	1.84	156.4	288	88	162
Relays	7.11	199.2	1416	103	735
Wiring	23.47	220.2	5168	105	2468
Conduit	1.87	251.9	471	108	203
Bonding Installations	.48	318.5	153	106	51
Equipment Supports	(6.72)	209.8	(1410)	101	(677)
Distribution Box	2.00	149.6	299	102	204
Equipment Supports - Wing	1.08	204.7	221	101	109
Equipment Supports - Body	3.64	244.5	890	100	364

RYAN

REPORT NO. 64B148	WEIGHT AND BALANCE REPORT XV-5A	PAGE 122
----------------------	------------------------------------	----------

WEIGHT EMPTY - WEIGHT AND BALANCE DETAILS (Cont'd.)

	WEIGHT	HORIZONTAL		VERTICAL	
		ARM	MOMENT	ARM	MOMENT
ELECTRONICS	(39.64)	153.3	(6075)	95	(3763)
UHF Transceiver, ARC-51X	(39.64)	153.3	(6075)	95	(3763)
Equipment	(38.02)	153.1	(5820)	95	(3626)
Transceiver	(30.30)	158.5	(4803)	95	(2877)
Radio, RT-702/ARC-51X	27.90	158.5	4422	95	2650
Mount, MT-2653	.40	158.5	63	92	37
Cooler, HD-615/ARC-51X	1.00	158.5	159	95	95
Indicator, ID-1003/ARC-51X	1.00	158.5	159	95	95
Antenna, AT256A/ARC	1.54	162.0	249	66	102
Control Unit C3984/ARC-51	3.00	110.0	330	115	345
Cabling	3.18	137.8	438	95	302
Installation	(1.62)	157.9	(255)	84	(137)
Transceiver	.94	155.8	146	92	87
Antenna	.68	161.0	109	73	50
FURNISHINGS AND EQUIPMENT	(212.95)	152.0	(32641)	112	(23953)
Accommodations for Personnel	(166.52)	142.1	(23715)	112	(18676)
Pilot's Seat-North American LW-2	(148.80)	141.4	(21067)	112	(16694)
Seat 9142-53009	116.50	140.0	16310	111	12931
Seat Adjusting Mechanism	5.96	152.0	906	130	775
Bulkhead Fittings (2)	3.10	145.5	451	106	329
Speed Sensor	.69	149.0	103	111	77
Rocket Catapult	21.75	147.0	3197	115	2501
Initiators T-30E2 (2)	.70	122.0	85	100	70
Cartridges (4)	.10	147.0	15	106	11
Seat Tracks & Supports	17.72	149.5	2648	112	1982
Miscellaneous Equipment	(12.06)	110.6	(1334)	111	(1334)
Instrument Panel	4.91	105.5	518	120	591
Instrument Panel Supports	1.54	106.5	164	115	178
Consoles	5.61	116.2	652	101	565

RYAN

REPORT NO. 64B148	WEIGHT AND BALANCE REPORT XV-5A	PAGE 123
----------------------	------------------------------------	----------

WEIGHT EMPTY - WEIGHT AND BALANCE DETAILS (Cont'd.)

	WEIGHT	HORIZONTAL		VERTICAL	
		ARM	MOMENT	ARM	MOMENT
FURNISHINGS AND EQUIPMENT (Cont'd.)					
Emergency Equipment	(34.37)	220.9	(7592)	115	(3943)
Fire Extinguishing System	(20.74)	223.8	(4642)	114	(2369)
Bottles (Including Charge)	12.44	219.0	2724	112	1393
Controls	3.17	245.6	779	115	364
Plumbing	4.93	222.4	1096	119	589
Bottle Supports	.20	216.5	43	114	23
Fire Detection System	9.36	210.2	1967	121	1130
Structure Overheat Warning	4.27	230.2	983	104	444
AIR CONDITIONING & ANTI-ICING					
Air Conditioning System	(34.27)	192.6	(6002)	137	(4690)
Cooling System	(33.15)	192.6	(6384)	137	(4542)
Fans (2)	13.53	192.0	2598	137	1854
Ducting	14.42	195.7	2822	137	1983
Plenum Chamber	4.99	184.1	919	136	677
Supports - Body	.21	212.7	45	132	28
Anti-Icing	(1.12)	194.4	(218)	132	(148)
Engine Anti-Icing Wiring	1.12	194.4	218	132	148
AUXILIARY GEAR					
Handling	(.66)	378.7	(250)	87	(58)
Jacking Fittings	.49	386.6	189	87	43
Leveling Fittings	.17	355.9	61	87	15
Arresting Gear	(26.73)	450.0	(12023)	107	(2858)
Decelerating Parachute	13.60	500.0	6800	110	1496
Chute Container & Fittings	5.37	485.0	2604	108	579
Chute Controls	7.76	337.5	2619	101	781

REPORT NO.
64B148

WEIGHT AND BALANCE REPORT
XV-5A

PAGE 125

2.7 Instrumentation

RYAN

REPORT NO. 64B148	WEIGHT AND BALANCE REPORT XV-5A	PAGE 126
----------------------	------------------------------------	----------

INSTRUMENTATION

	WEIGHT	HORIZONTAL		VERTICAL	
		ARM	MOMENT	ARM	MOMENT
Nose Boom	5.60	- 1.91	- 11	94	526
Fan Overspeed Control	8.32	121.91	1014	106	880
Circuitry Fan Bearing Heat	5.31	163.80	870	95	504
Circuitry Fan RPM & Limit	10.71	159.75	1711	94	1011
Auto Stab. System Instrumentation	1.70	109.00	185	112	190
G.E. Fan Slip Rings (2)	21.08	204.25	4306	101	2123
Tubing for Static Test Wiring	.28	212.86	60	102	29
D020 Signal Access & Harn. Standoffs	2.03	242.00	491	120	244
D021 Oat Probe Installation	1.16	256.03	297	104	120
D022 Probe - Nose, Yaw & Angle	2.38	- 67.60	- 161	95	226
D023 Temp. Measurement Instl.	10.02	196.70	1971	121	1212
D025 Probe - Hyd. Temp.	.54	165.00	89	128	69
D026 Transducer Installation	1.39	1.44	2	95	132
D027 Pos. Potentiometer	.24	495.83	119	113	27
D028 Pos. Potentiometer-Rudder	.15	437.00	73	115	17
D029 Pos. Potentiometer-Aileron	.45	299.00	135	104	47
D030 Force Transducers	.09	122.22	11	100	9
D031 Pos. Potentiometer-Aileron Tab	.07	317.70	22	102	7
D033 Pot.-Fwd.Louvre Servo-Fan Exit	.42	211.00	89	97	41
D034 Pot.-Aft Louvre Servo-Fan Exit	.42	300.00	126	97	41
D035 Photo Recorder Installation	2.25	104.00	234	99	223
D036 Pot.-Pitch Fan Exit Door	.22	88.00	19	87	19
D037 Pos. Potentiometer-Rudder Hinge	.11	513.00	56	183	20
D039 Potentiometer-Stick-Long & Lat.	.45	113.33	51	87	39
D040 Potentiometer-Rudder Pedal	.28	94.00	26	110	31
D041 Post.-Potentiometer-Control Col.	.29	138.00	40	86	25
D044 C.G. Accel. Mtng. Box	9.54	241.71	2306	121	1159
D045 Accels. - Wing & Tail	1.40	380.00	532	141	198
D047 Inverter Elapsed Time	.23	455.00	105	113	26
D049 Equip.-Data Acquisition					
PCM Package	72.78	143.50	10444	107	7787
Vertical Gyro	5.00	115.00	575	96	480
Analog Record Electronics	10.00	99.00	990	95	950
Tape Transport	25.00	98.70	2467	94	2350
Telemetry Package	18.70	135.60	2536	102	1907
D050 Signal Conditioner	46.90	128.70	6036	105	4925
Temp. Syst. Instl. Box	39.30	137.00	5384	96	3773
-3 Fwd. Mounting Board	11.00	108.00	1188	93	1023
-5 Aft Mounting Board	5.40	130.00	702	94	508
D051 Antenna-Telemetry	2.71	177.50	481	134	363
D054 Wiring	123.38	208.12	25678	104	12832
D057 Press. Probes - Cooling Syst.	11.91	202.30	2409	112	1334
D058 Pos. Potentiometer-Elevator	.09	518.00	47	206	19

RYAN

REPORT NO. 64B148	WEIGHT AND BALANCE REPORT XV-5A	PAGE 127
----------------------	------------------------------------	----------

INSTRUMENTATION (Cont'd.)

	WEIGHT	HORIZONTAL		VERTICAL	
		ARM	MOMENT	ARM	MOMENT
Tape Remaining Indicator	1.50	110.00	165	115	173
Correlation Counter	3.30	131.00	432	109	360
Engine Parameters	13.65	190.80	2604	148	2020
Wheel Contact Indicator	.80	125.00	100	90	72
Ballast Bracket	2.70	481.00	1299	95	257
Nickel-Cadium Battery	15.00	128.00	1920	90	1350
Position Pot.-Flap	2.50	275.00	688	105	263
Position Pot.-Wing Fan Louvres	4.00	200.00	800	105	420
NEFF Power Supply	9.00	135.00	1215	95	855
Boom-Stab. Angle of Attack	3.25	475.00	1544	96	312
TOTAL-INSTRUMENTATION	515.00	162.03	84472	104	53528

RYAN

REPORT NO.
64B148

WEIGHT AND BALANCE REPORT
XV-5A

PAGE 129

2.8 Moment Change-Landing Gear Extended

RYAN

REPORT NO. 64B148	WEIGHT AND BALANCE REPORT XV-5A	PAGE 131			
MOMENT CHANGE - LANDING GEAR EXTENSION (Retractable Item Only)					
	WEIGHT	HORIZONTAL		VERTICAL	
		ARM	MOMENT	ARM	MOMENT
LANDING GEAR RETRACTED (As Reflected in this Report)	(353.76)	281.0	(99401)	88	(31188)
Main Gear	(276.54)	(327.2)	(90491)	(90)	(24999)
Shock Strut, Oil & Axle	88.20	329.0	29019	92	8096
Drag Brace	30.28	311.2	9424	88	2657
Side Brace	10.10	312.6	3157	87	879
Vee Brace & Positioning Mechanism	25.57	293.4	7503	91	2320
Retracting Cylinder	7.06	305.7	2158	90	635
Wheels	28.90	352.7	10193	92	2659
Brakes	28.38	352.7	10010	92	2611
Tires	23.70	352.7	8359	92	2180
Hydraulic Hoses, Brackets, etc.	3.12	308.0	961	92	288
Insulation	31.23	310.8	9707	86	2674
Nose Gear	(77.22)	(115.4)	(8910)	(80)	(6189)
Shock Strut, Oil & Shimmy Damper	44.23	120.3	5321	78	3450
Braces & Jury Links	8.41	122.2	1028	85	712
Retracting Cylinder	2.18	124.1	271	88	192
Wheel	9.22	99.2	915	83	765
Tire	10.95	99.2	1086	83	909
Aft Door	2.23	129.6	289	72	161

RYAN

REPORT NO. 64B148	WEIGHT AND BALANCE REPORT XV-5A	PAGE 132
----------------------	------------------------------------	----------

MOMENT CHANGE - LANDING GEAR EXTENSION
(Retractable Items Only)

	WEIGHT	HORIZONTAL		VERTICAL	
		ARM	MOMENT	ARM	MOMENT
LANDING GEAR EXTENDED					
<u>VTOL</u> (Vertical Take-off Position)	(353.76)	261.6	(92551)	60	(21124)
Main Gear	(276.54)	(297.4)	(82232)	(61)	(16789)
Shock Strut, Oil & Axle	88.20	292.4	25786	58	5081
Drag Brace	30.28	306.0	9266	75	2274
Side Brace	10.10	292.2	2951	63	636
Vee Brace	25.57	293.4	7503	91	2320
Retracting Cylinder	7.06	318.0	2245	91	642
Wheels	28.90	296.0	8554	42	1214
Brakes	28.38	296.0	8696	42	1234
Tires	23.70	296.0	7015	42	995
Hydraulic Hoses, Brackets, etc.	3.12	290.4	906	76	236
Insulation	31.23	291.1	9310	69	2150
Nose Gear	(77.22)	(133.6)	(10319)	(56)	(4342)
Shock Strut, Oil & Shimmy Damper	44.23	135.8	6006	58	2565
Braces & Jury Links	8.41	119.6	1006	76	642
Retracting Cylinder	2.18	117.1	255	78	170
Wheel	9.22	135.6	1250	41	378
Tire	10.95	135.6	1485	41	449
Aft Door	2.23	142.0	317	62	138

RYAN

REPORT NO. 64B148	WEIGHT AND BALANCE REPORT XV-5A	PAGE 133			
MOMENT CHANGE - LANDING GEAR EXTENSION (Retractable Items Only)					
		HORIZONTAL		VERTICAL	
	WEIGHT	ARM	MOMENT	ARM	MOMENT
LANDING GEAR EXTENDED					
CTOL (Conventional Take-off Position)					
Main Gear	(353.76)	251.0	(88782)	59	(20742)
Shock Strut, Oil & Axle	88.20	278.3	24544	58	5081
Drag Brace	30.28	297.1	8997	70	2106
Side Brace	10.10	280.0	2828	63	636
Vee Brace	25.57	291.1	7444	88	2261
Retracting Cylinder	7.06	305.4	2156	85	600
Wheels	28.90	276.0	7976	42	1214
Brakes	29.38	276.0	8109	42	1234
Tires	23.70	276.0	6541	42	995
Hydraulic Hoses, Brackets, etc.	3.12	283.0	883	76	236
Insulation	31.23	287.7	8985	65	2037
Nose Gear - Same as VTOL	(77.22)	133.6	(10319)	56	(4342)
SUMMARY - MOMENT CHANGE					
RETRACTED TO VTOL					
Retracted Main and Nose			99401		31188
VTOL Main and Nose			92551		21124
MOMENT CHANGE: RETRACTED TO VTOL			-6850		-10064
RETRACTED TO CTOL					
Retracted Main and Nose			99401		31188
CTOL Main and Nose			88782		20742
MOMENT CHANGE: RETRACTED TO CTOL			-10619		-10446
VTOL Position			92551		21124
CTOL Position			88782		20742
Δ MOMENT CHANGE: VTOL TO CTOL			-3769		- 382

RYAN

REPORT NO.
64B148

WEIGHT AND BALANCE REPORT
XV-5A

PAGE 135

2.9 Fuel Center of Gravity Graphs

FUEL CENTER OF GRAVITY TRAVEL
FORWARD MAIN TANK

WATERLINE - INCHES

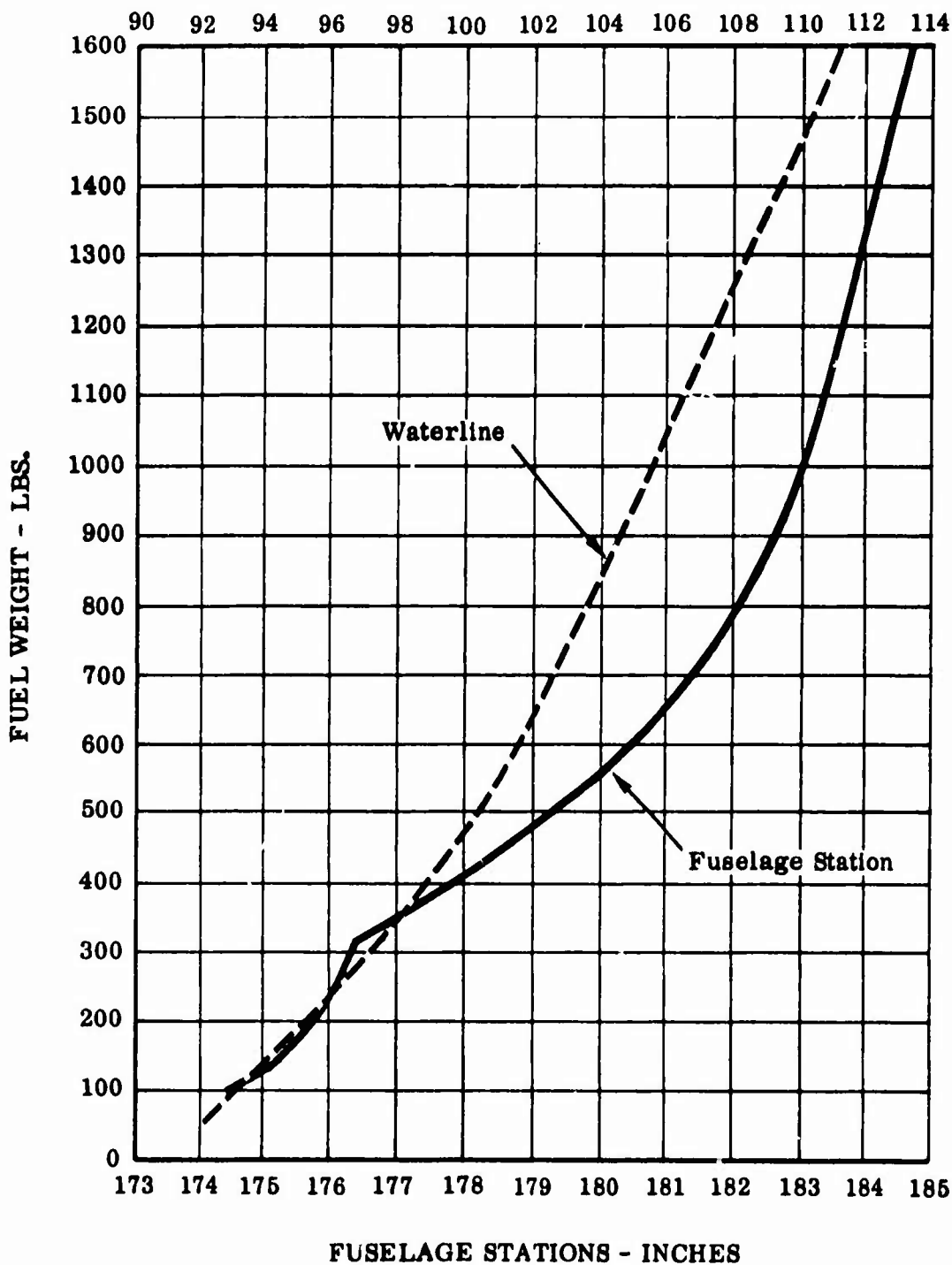

Figure 3

FUEL CENTER OF GRAVITY TRAVEL
AFT MAIN TANK

WATERLINE - INCHES

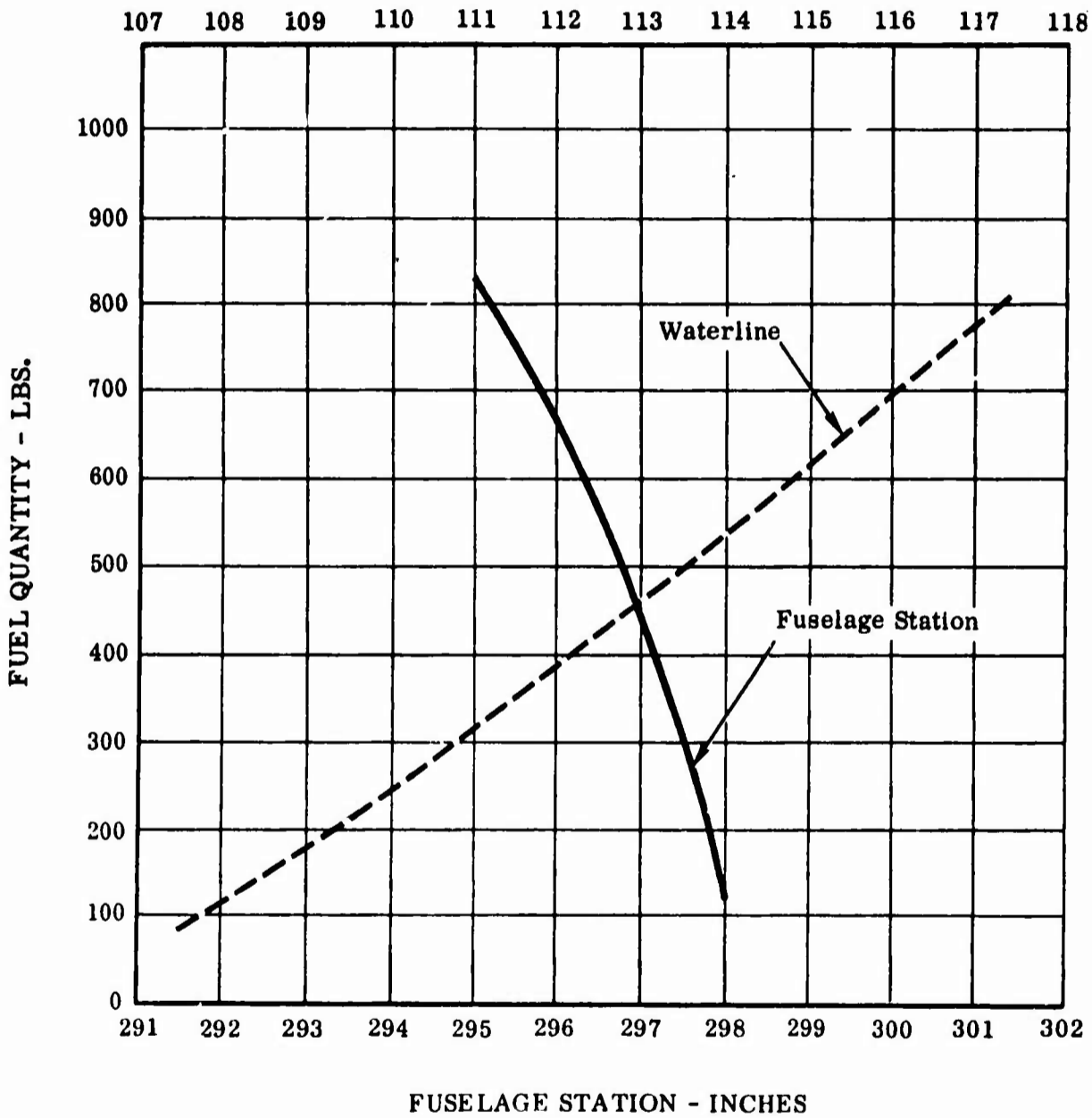

Figure 4

FUEL CENTER OF GRAVITY TRAVEL
DORSAL AUXILIARY FUEL TANK

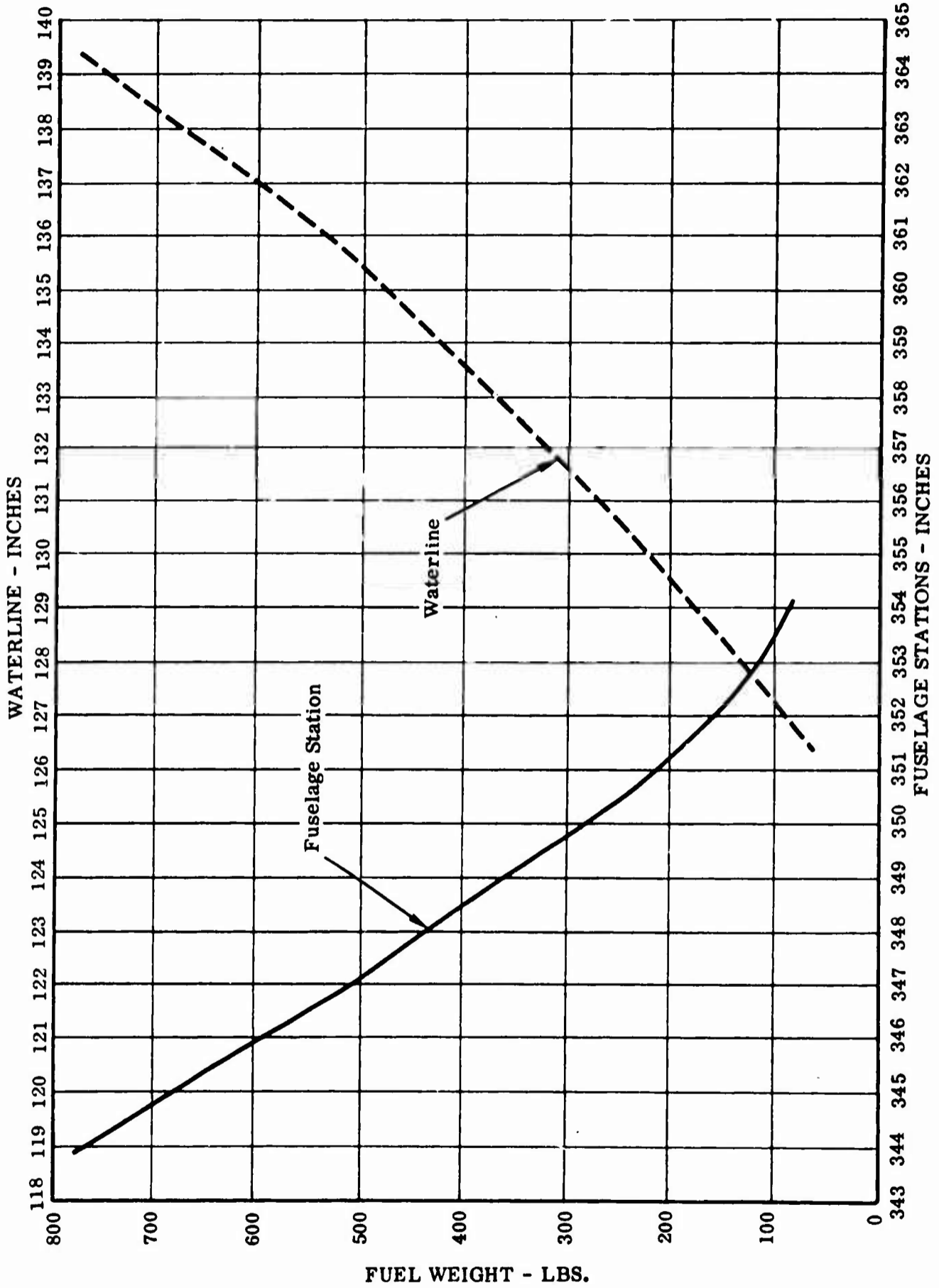

Figure 5

RYAN

REPORT NO.
64B148

WEIGHT AND BALANCE REPORT
XV-5A

PAGE 141

2.10 Gross Weight Balance Calculations

RYAN

REPORT NO. 64B148	WEIGHT AND BALANCE REPORT XV-5A			PAGE 143	
GROSS WEIGHT 9200 LBS. - NO INSTRUMENTATION					
	WEIGHT	HORIZONTAL		VERTICAL	
		ARM	MOMENT	ARM	MOMENT
WEIGHT EMPTY (Gear Up)	8063	248.4	2602587	113	911119
Crew	200	137	27400	111	22200
Fuel - Unusable - Fwd.	4	180	720	92	368
Fuel - Unusable - Aft	22	299	6578	105	2310
Oil - Trapped	3	204	612	136	408
Oil - Engine	12	204	2448	136	1632
Auxiliary Oxygen System	19	147	2793	100	1900
Emergency Escape Axle	2	140	280	108	216
Usable Fuel					
Forward Main Tank	438	178.4	78139	99	43362
Aft Main Tank	437	297.0	129789	113	49381
GROSS WEIGHT - 9200 Lbs. (Gear Up)	9200	245.0	2251346	111	1032896
	$\frac{245.0 - 211.14}{112.92} =$		30.0% M.A.C.		
Extend Gear to VTOL Position			- 6850		- 10064
GROSS WEIGHT - 9200 Lbs. - VTOL	9200	244.2	2244496	110	1022832
	$\frac{244.2 - 211.14}{112.92} =$		29.3% M.A.C.		
Δ Change - Gear VTOL to CTOL			- 3769		- 382
GROSS WEIGHT - 9200 Lbs. - CTOL	9200	243.8	2240727	110	1022450
	$\frac{243.8 - 211.14}{112.92} =$		28.9% M.A.C.		

RYAN

REPORT NO. 64B148	WEIGHT AND BALANCE REPORT XV-5A	PAGE 144
----------------------	------------------------------------	----------

GROSS WEIGHT 9200 LBS. - INCLUDING INSTRUMENTATION

	WEIGHT	HORIZONTAL		VERTICAL	
		ARM	MOMENT	ARM	MOMENT
WEIGHT EMPTY (Gear Up)	8063	248.4	2002587	113	911119
Crew	200	137	27400	111	22200
Fuel - Unusable - Fwd.	4	180	720	92	368
Fuel - Unusable - Aft	22	299	6578	105	2310
Oil - Trapped	3	204	612	136	408
Oil - Engine	12	204	2448	136	1632
Auxiliary Oxygen System	19	147	2793	100	1900
Emergency Escape Axe	2	140	280	108	216
Instrumentation	515	162	84472	104	53528
Usable Fuel					
Forward Main Tank	180	175.6	31608	95	17100
Aft Main Tank	180	297.8	53604	109	19620
GROSS WEIGHT - 9200 Lbs. (Gear Up)	9200	240.8	2213102	111	1030401
	$\frac{240.8 - 211.14}{112.92} =$	26.3%	M.A.C.		
Extend Gear to VTOL Position			- 6850		- 10064
GROSS WEIGHT - 9200 Lbs. - VTOL	9200	240.0	2206352	110	1020337
	$\frac{240.0 - 211.14}{112.92} =$	25.6%	M.A.C.		
Δ Change - Gear - VTOL to CTOL			- 3769		- 382
GROSS WEIGHT - 9200 Lbs. - CTOL	9200	239.6	2202483	110	1019955
	$\frac{239.6 - 211.14}{112.92} =$	25.2%	M.A.C.		

RYAN

REPORT NO. 64B148	WEIGHT AND BALANCE REPORT XV-5A			PAGE 145	
GROSS WEIGHT - 20 MINUTE MISSION					
	WEIGHT	HORIZONTAL		VERTICAL	
		ARM	MOMENT	ARM	MOMENT
WEIGHT EMPTY (Gear Up)	8063	248.4	2002587	113	911119
Crew	200	137	27400	111	22200
Fuel - Unusable - Fwd.	4	180	720	92	368
Fuel - Unusable - Aft	22	299	6578	105	2310
Oil - Trapped	3	204	612	136	408
Oil - Engine	12	204	2448	136	1632
Auxiliary Oxygen System	19	147	2793	100	1900
Emergency Escape Axe	2	140	280	108	216
Instrumentation	515	162	84472	104	53528
Usable Fuel					
Forward Main Tank	566	180.1	101937	101	57166
Aft Main Tank	566	296.4	167764	114	64524
GROSS WEIGHT - 20 Minute Mission	9972	240.7	2397591	111	1113255
	$\frac{240.7 - 211.14}{112.92} =$	26.2% M.A.C.			
Extend Gear to VTOL Position			- 6850		- 10064
GROSS WEIGHT - 20 Minute - VTOL	9972	239.9	2390741	110	1103191
	$\frac{239.9 - 211.14}{112.92} =$	25.5% M.A.C.			
Δ Change - Gear - VTOL to CTOL			- 3769		- 382
GROSS WEIGHT - 20 Minute - CTOL	9972	239.6	2386972	109	1102809
	$\frac{239.6 - 211.14}{112.92} =$	25.2% M.A.C.			

RYAN

REPORT NO. 64B148	WEIGHT AND BALANCE REPORT XV-5A	PAGE 146
----------------------	------------------------------------	----------

GROSS WEIGHT - 45 MINUTE MISSION

	WEIGHT	HORIZONTAL		VERTICAL	
		ARM	MOMENT	ARM	MOMENT
WEIGHT EMPTY (Gear Up)	8063	248.4	2002587	113	911119
Crew	200	137	27400	111	22200
Fuel - Unusable - Fwd.	4	180	720	92	368
Fuel - Unusable - Aft	22	299	6578	105	2310
Oil - Trapped	3	204	612	136	408
Oil - Engine	12	204	2448	136	1632
Auxiliary Oxygen System	19	147	2793	100	1900
Emergency Escape Axe	2	140	280	108	216
Instrumentation	515	162	84472	104	53528
Usable Fuel					
Forward Main Tank	1017	183.1	186213	106	107802
Aft Main Tank	830	295.0	244850	118	97940
Aft Dorsal Tank	186	351.5	65379	129	23994
GROSS WEIGHT - 45 Minute Mission	10873	241.6	2624332	112	1223417
	$\frac{241.6 - 211.14}{112.92} =$	27.0% M.A.C.			
Extend Gear to VTOL Position			- 6850		- 10064
GROSS WEIGHT - 45 Minute - VTOL	10873	241.0	2617482	111	1213353
	$\frac{241.0 - 211.14}{112.92} =$	26.4% M.A.C.			
Δ Change - Gear - VTOL to CTOL			- 3769		- 382
GROSS WEIGHT - 45 Minute - CTOL	10873	240.6	2613713	111	1213071
	$\frac{240.6 - 211.14}{112.92} =$	26.1% M.A.C.			

RYAN

REPORT NO. 64B148	WEIGHT AND BALANCE REPORT XV-5A			PAGE 147	
GROSS WEIGHT - FULL FUEL INCLUDING AFT AUXILIARY TANK					
	WEIGHT	HORIZONTAL		VERTICAL	
		ARM	MOMENT	ARM	MOMENT
WEIGHT EMPTY (Gear Up)	8063	248.4	2002587	113	911119
Crew	200	137	27400	111	22200
Fuel - Unusable - Fwd.	4	180	720	92	368
Fuel - Unusable - Aft	22	299	6578	105	2310
Fuel - Unusable - Auxiliary	10	360	3600	107	1070
Oil - Trapped	3	204	612	136	408
Oil - Engine	12	204	2448	136	1632
Auxiliary Oxygen System	19	147	2793	100	1900
Emergency Escape Axe	2	140	280	108	216
Instrumentation	515	162	84472	104	53528
Install Auxiliary Fuel Tank	35	339	11865	140	4900
ZERO FUEL - WITH AUX. AFT TANK	8885	241.5	2143355	111	999651
	$\frac{241.5 - 211.14}{112.92} =$	26.9% M.A.C.			
Usable Fuel					
Forward Main Tank - 246 gal.	1600	184.5	295200	111	177600
Aft Main Tank - 128 gal.	830	295.0	244850	118	97940
Aft Auxiliary Tank - 120 gal.	780	344.0	268320	139	108420
TOTAL - FULL FUEL (Gear Up)	12095	244.2	2951725	113	1383611
	$\frac{244.2 - 211.14}{112.92} =$	29.3% M.A.C.			
Extend Gear to VTOL Position			- 6850		- 10064
GROSS WEIGHT - FULL FUEL - VTOL	12095	243.7	2944875	113	1373547
	$\frac{243.7 - 211.14}{112.92} =$	28.8% M.A.C.			
Δ Change - Gear - VTOL to CTOL			- 3769		- 382
GROSS WEIGHT - FULL FUEL - CTOL	12095	243.3	2941106	113	1373165
	$\frac{243.3 - 211.14}{112.92} =$	28.5% M.A.C.			

RYAN

REPORT NO. 64B148	WEIGHT AND BALANCE REPORT XV-5A			PAGE 148	
GROSS WEIGHT - EXTENDED RANGE					
	WEIGHT	HORIZONTAL		VERTICAL	
		ARM	MOMENT	ARM	MOMENT
WEIGHT EMPTY (Gear Up)	8063	248.4	2002587	113	911119
Crew	200	137	27400	111	22200
Fuel - Unusable - Fwd.	4	180	720	92	368
Fuel - Unusable - Aft	22	299	6578	105	2310
Fuel - Unusable - Auxiliary	10	360	3600	107	1070
Fuel - Unusable - Extended Range	13	236	3068	75	975
Oil - Trapped	3	204	612	136	408
Oil - Engine	12	204	2448	136	1632
Auxiliary Oxygen System	19	147	2793	100	1900
Emergency Escape Axe	2	140	280	108	216
Install Auxiliary Fuel Tank	35	339	11865	140	4900
Install Extended Range Fuel Tank	120	224	26880	83	9960
ZERO FUEL - EXTENDED RANGE	8503	245.9	2088831	111	953967
					$\frac{245.9 - 211.14}{112.92} =$
					30.8% M.A.C.
Usable Fuel					
Forward Main Tank - 246 gal.	1600	184.5	295200	111	177600
Aft Main Tank - 128 gal.	830	295.0	244850	118	97940
Aft Auxiliary Tank - 120 gal.	780	344.0	268320	139	108420
Extended Range Tank - 121 gal.	787	224.0	176228	83	65321
TOTAL - EXTENDED RANGE (Gear Up)	12500	246.0	3073429	111	13248
					$\frac{246.0 - 211.14}{112.92} =$
					30.9% M.A.C.
Extend Gear to VTOL Position			- 6850		- 10064
GROSS WEIGHT - EXTENDED RANGE - VTOL	12500	245.5	3066579	111	1393180
					$\frac{245.5 - 211.14}{112.92} =$
					30.0% M.A.C.
Δ Change - Gear - VTOL to CTOL			- 3769		- 382
GROSS WEIGHT - EXTENDED RANGE - CTOL	12500	245.2	3062810	111	1392802
					$\frac{245.2 - 211.14}{112.92} =$
					30.2% M.A.C.

RYAN

REPORT NO.
64B148

WEIGHT AND BALANCE REPORT
XV-5A

PAGE 149

2.11 Gross Weight Center of Gravity Graph

CENTER OF GRAVITY TRAVEL

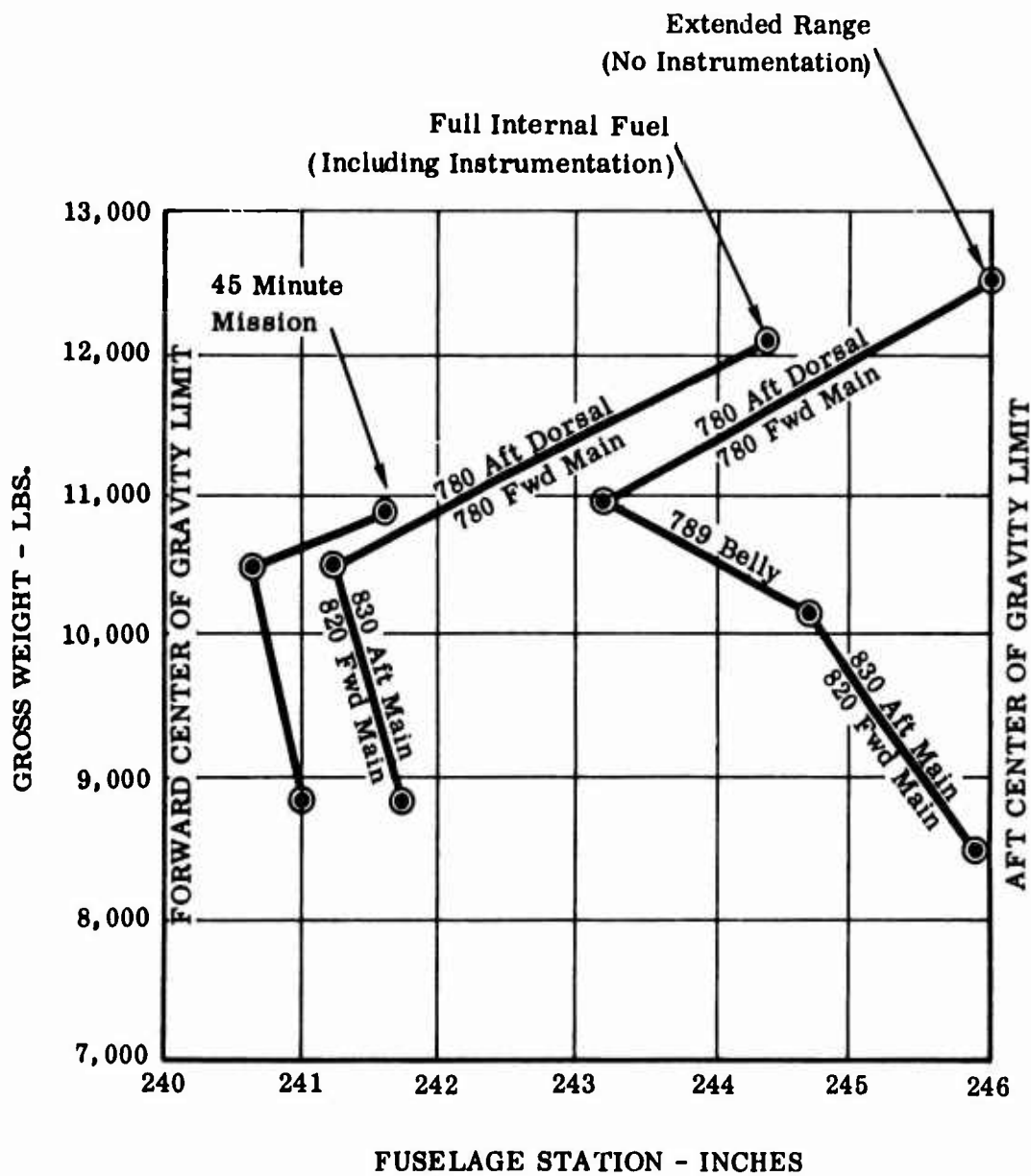

Figure 6

REPORT NO.
64B148

WEIGHT AND BALANCE REPORT
XV-5A

PAGE 153

2.12 Determination of Unusable Fuel

RYAN

REPORT NO. 64B148	WEIGHT AND BALANCE REPORT XV-5A	PAGE 155
----------------------	------------------------------------	----------

UNUSABLE FUEL

The unusable fuel was determined at various airplane attitudes by actual measurement. The airplane was positioned at the selected attitude and a measured amount of fuel was introduced into the system. The fuel pumps were turned on and pumped fuel to an external tank until cavitation was observed in the lines. The amount of fuel in the external tank was determined and subtracted from the original measured amount; the difference being the Unusable Fuel.

Different airplanes attitudes were measured and the resulting fuel is shown below. However, the Unusable Fuel as used in this report was selected at the 8° nose-up attitude since it was felt that this is the most critical in flight as it is the approximate angle of the aircraft (relative to gravity) on the final approach with a 3 degree glide slope and $V = 1.2 V_{stall}$.

The center of gravity of the Unusable Fuel was calculated since the amounts were too small to determine c.g. by actual weighing.

Airplane Attitude	Amount of Unusable Fuel (Lbs.)		
	<u>Fwd. Tank</u>	<u>Aft Tank</u>	<u>Total</u>
Level	5	6	11
+5° (Nose Up)	4	4	8
+8° (Nose Up)	4	22	26
+15.7° (Nose Up)	56	67	123
-5.2° (Nose Down)	3	5	8
-10.5° (Nose Down)	5	24.5	29.5
-15° (Nose Down)	7.5	45	52.5

RYAN

REPORT NO.
64B148

WEIGHT AND BALANCE REPORT
XV-5A

PAGE 157

3.0 Supplementary Data

RYAN

REPORT NO.
64B148WEIGHT AND BALANCE REPORT
XV-5A

PAGE 159

WEIGHING PROCEDURE

1. PRE-WEIGHING INVENTORY

- A. Fwd. and Aft Main Fuel tanks will be drained through sumps until only trapped fuel remains. Airplane is in level position for this operation.
- B. Engine oil tanks are serviced to the prescribed four quart level per tank.
- C. Hydraulic reservoirs should be serviced to the operational level.
- D. A wet battery installed.
- E. All access panels, canopies, etc. will be in place with full complement of fasteners.
- F. A visual count of all flight test equipment will be made to determine exact weight of configuration being used.
- G. A similar check will be made to assure that all basic airplane equipment is aboard.
- H. All control surfaces will be in a faired position and all louvers shut.
- I. A list will be made of ground locks, jack fittings, wheel chocks and any other tare item to be deducted from the scale weight.

2. POSITIONING AIRCRAFT ON SCALES

- A. When the portable platform type scales are used, it is recommended that the aircraft be towed until main gear wheels are each positioned on scales. Then jack airplane at the wing and tail positions until a scale can be rolled in from the side under the nose wheel. This is required because of limited clearance between the bottom of nose fuselage and high point of scale.
- B. The left or right hand main landing gear door sill - 143F060 at fuselage station 287 to 365, waterline 93.25 and buttock line 24 - may be used as reference plane to level aircraft.

3. REFERENCE MEASUREMENTS

After measuring oleo extensions, the corresponding fuselage stations for the centerline points of the nose and main gear axles may be obtained from the tables on the next page. For an actual verification of this wheel base dimension the following procedure should be employed. Connect the main gear jacking lugs with a taut wire and measure the distance from the nose axle centerline along a line perpendicular to the wire. Because the lugs are offset from the main gear axle centerlines, an increment of .17 inches must be added in the CTOL position and .30 inches subtracted in the VTOL position.

Should electronic weighing cells be used, the wing jacking points are at fuselage station 226.5 and the tail jack is at 384.3.

REPORT NO.
64B148

WEIGHT AND BALANCE REPORT
XV-5A

PAGE 161

Y.T.O.L. MAIN L.G. EXT.
VS.

FUS. STA. AT OF AXLE	
INCH	FUS. STA.
0	295.32
1	295.57
2	295.81
3	296.05
4	296.29
5	296.53
6	296.78
7	297.02
8	297.26
9	297.51

COMPR.

STATIC

EXTEN.

C.T.O.L. MAIN L.G. EXT.
VS.

FUS. STA. AT OF AXLE	
INCH	FUS. STA.
0	276.38
1	276.26
2	276.14
3	276.02
4	275.90
5	275.78
6	275.66
7	275.53
8	275.41
9	275.29

COMPR.

STATIC

EXTEN.

NOSE GEAR EXTENSION
VS.

FUS. STA. AT E OF AXLE	
INCH	FUS. STA.
0	136.11
1	136.02
2	135.93
3	135.85
4	135.76
5	135.67
5.3	135.61
6	135.59
7	135.50
8	135.41

COMPR.

STATIC

EXTEN.

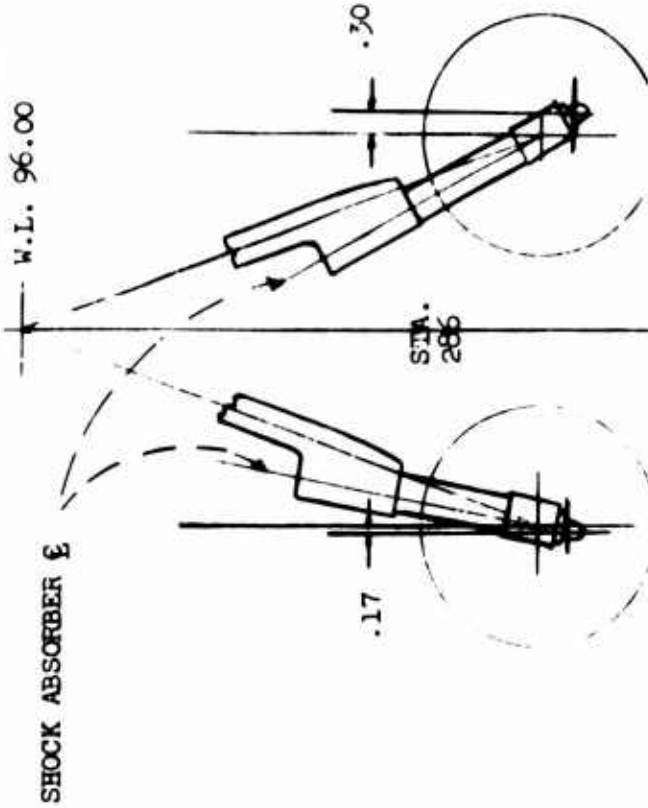
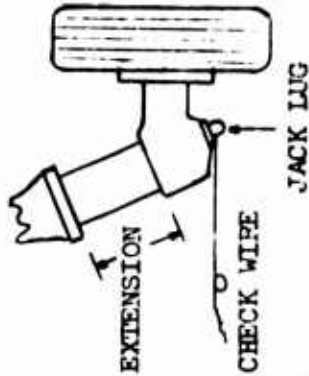

SHOCK ABSORBER E

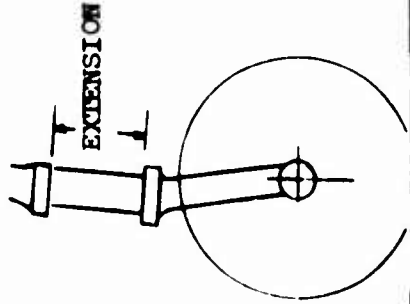

C.T.O.L.
STATIC COND.

140.1"

160.4"
STATIC COND.
V.T.C.L.

1. Nose Cone
2. Forward Bulkhead, Pitch-fan
3. Forward Fuselage Section
4. Aft Bulkhead, Pitch-fan
5. Windshield
6. Canopy
7. Front Spar Bulkhead
8. Canted Bulkhead, Forward Fuselage
9. Lower Longeron, Forward Fuselage, L. H.
10. Upper Longeron, Forward Fuselage, L. H.
11. Wing, R. H.
12. Aileron, R. H.
13. Flap, R. H.
14. Right Hand Engine Master Mounts
15. Left Hand Engine Master Mounts
16. Center Fuselage Space Frame
17. Rear Spar Bulkhead
18. Aft Fuselage Section
19. External Longeron
20. Upper Longeron, Aft Fuselage, L. H.
21. Vertical Stabilizer Leading Edge Fairing
22. Vertical Stabilizer
23. Vertical Stabilizer Rear Spar
24. Vertical Stabilizer Center Spar
25. Tail Cone
26. Vertical Stabilizer Rear Spar Bulkhead
27. Vertical Stabilizer Forward Spar
28. Vertical Stabilizer Rib
29. Vertical Stabilizer Center Spar Bulkhead
30. Vertical Stabilizer Forward Spar Bulkhead
31. Tailpipe Aft Bulkhead
32. Tailpipe Exhaust Fairing
33. Lower Longeron, Aft Fuselage, L. H.
34. Rear Wing Spar Fuselage Attach Structure
35. Rudder
36. Rudder Trim Tab
37. Horizontal Stabilizer
38. Horizontal Stabilizer Forward Spar
39. Horizontal Stabilizer Tip
40. Horizontal Stabilizer Center Spar
41. Horizontal Stabilizer Rear Spar
42. Horizontal Stabilizer Rib
43. Elevators
44. Elevator Rib
45. Flap, L. H.
46. Aileron, L. H.
47. Aileron Aft Spar, L. H.
48. Aileron Rib, L. H.
49. Aileron Front Spar, L. H.
50. Wing Aft Spar, L. H.
51. Cap Rib
52. Wing Tip, L. H.
53. Outboard Wing Panel, L. H.
54. Leading Edge Fairing
55. Wing Front Spar, L. H.
56. Inboard Wing Panel
57. Nose Fan Pitch Control Doors
58. Main Landing Gear
59. Main Landing Gear Doors
60. Nose Landing Gear
61. Aileron Trim Tab
62. Center Fuselage Upper Access Cover
63. Center Fuselage Lower Access Cover
64. Center Fuselage Side Access Cover

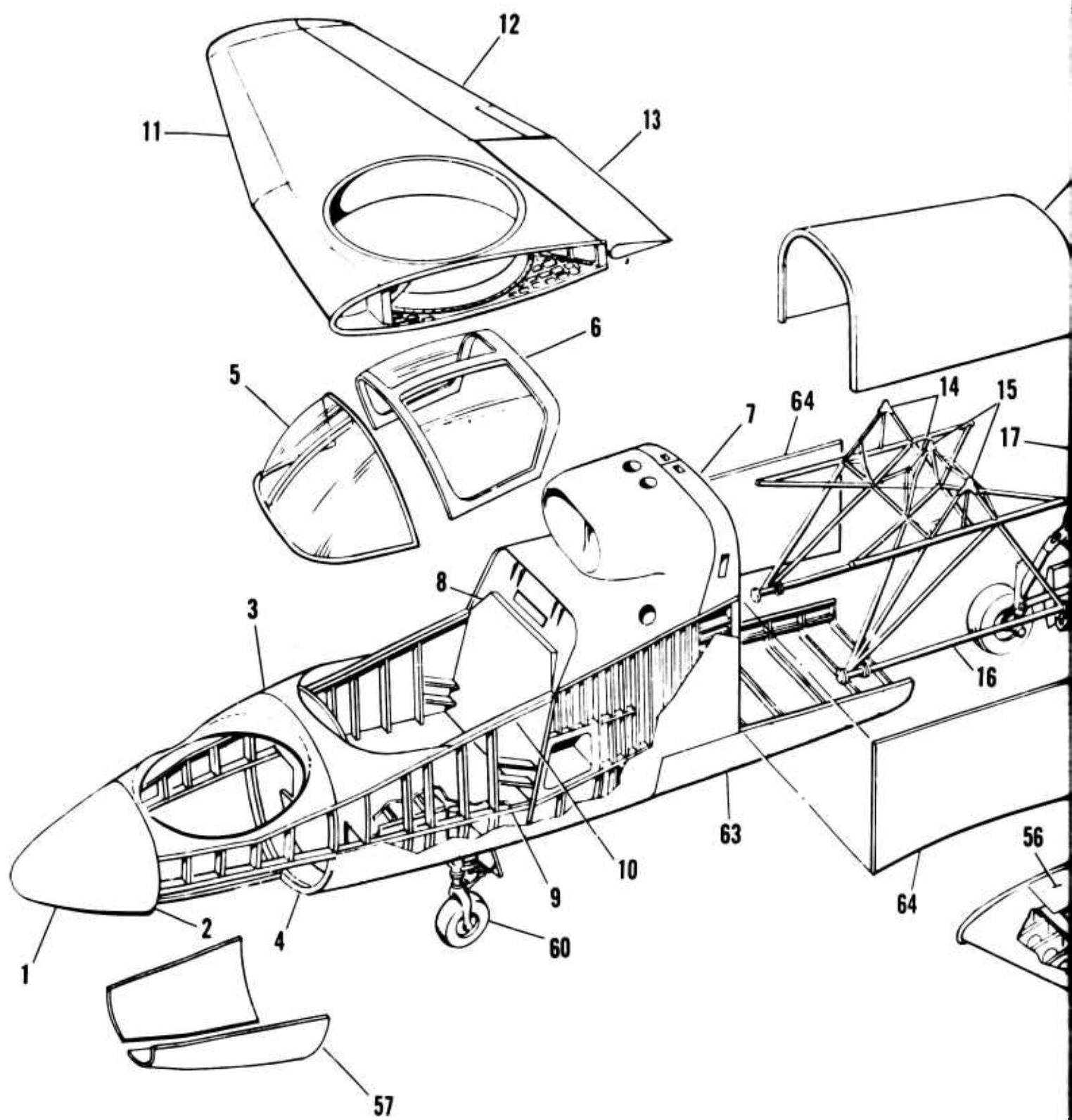

AIRCRAFT BASIC STRUCTURAL ARRANGEMENT

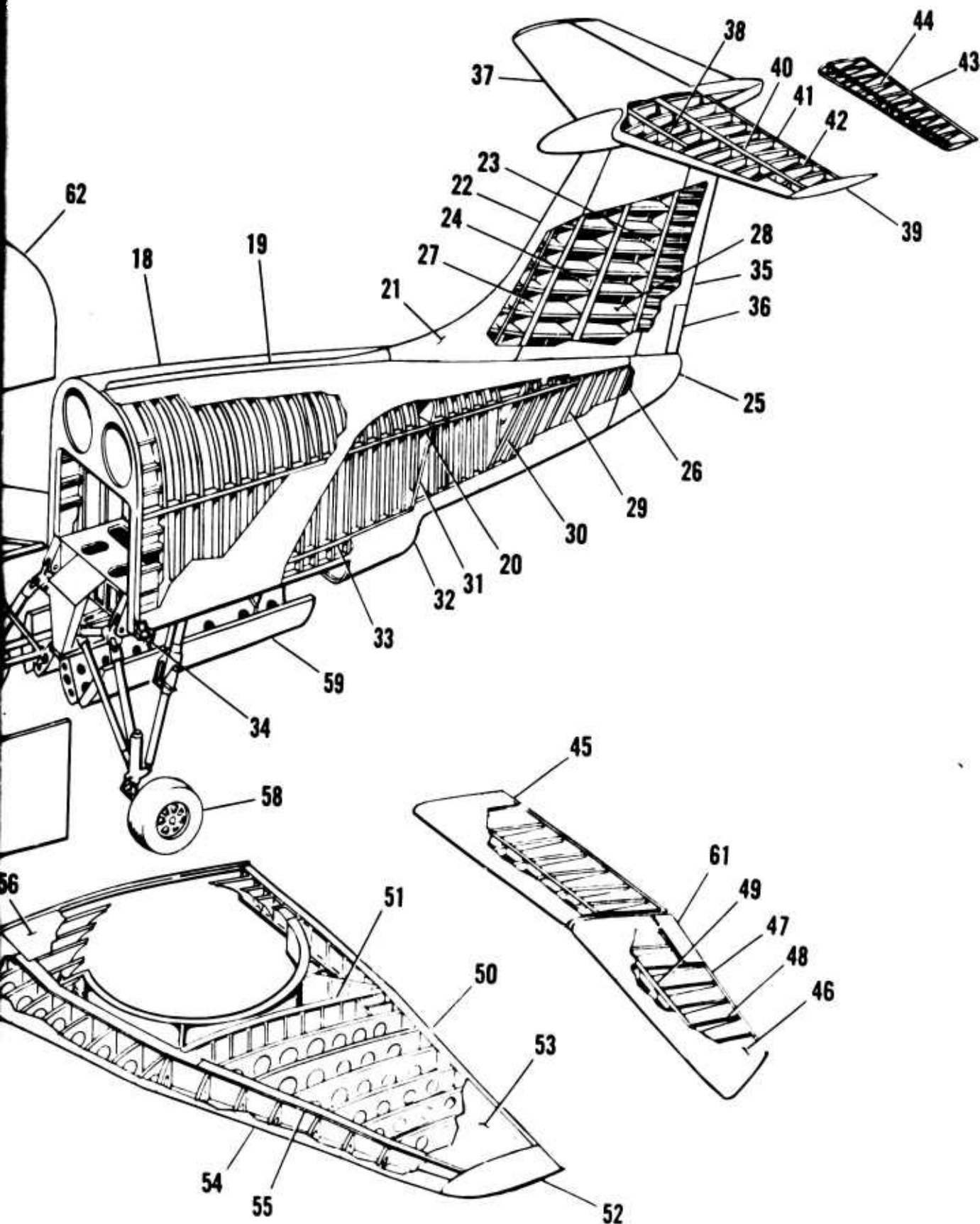

FUS
9800
51A

WL 10000 FRL

221

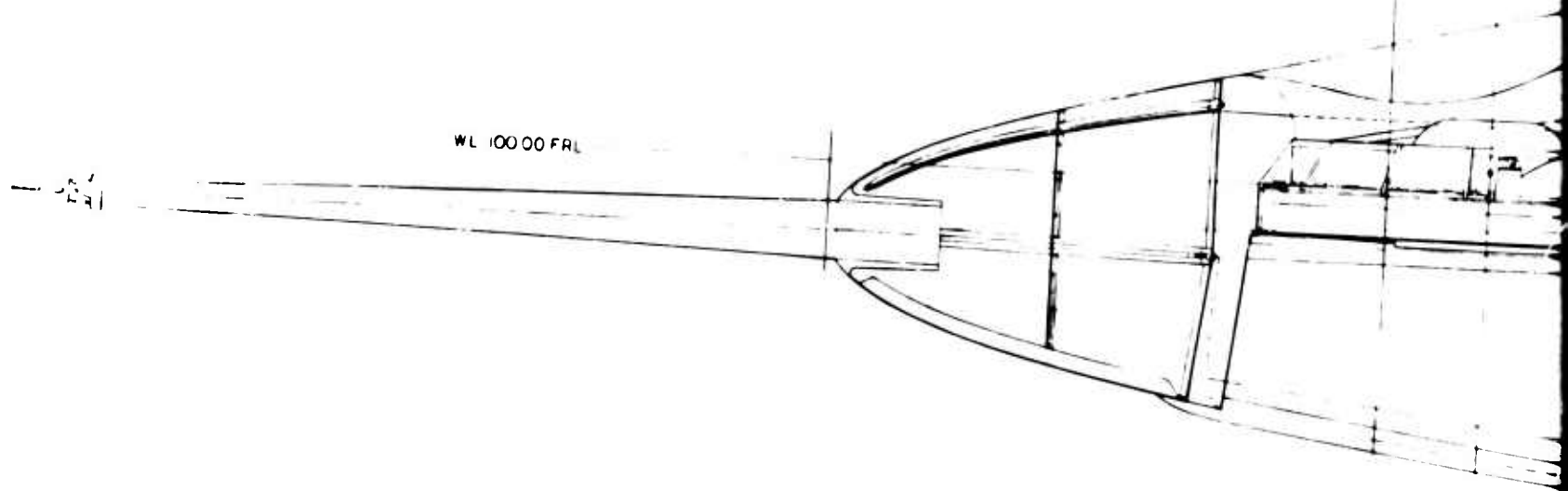

FJS
9800
51A

FJS
9800
51A

FJS
9800
51A

FJS
9800
51A

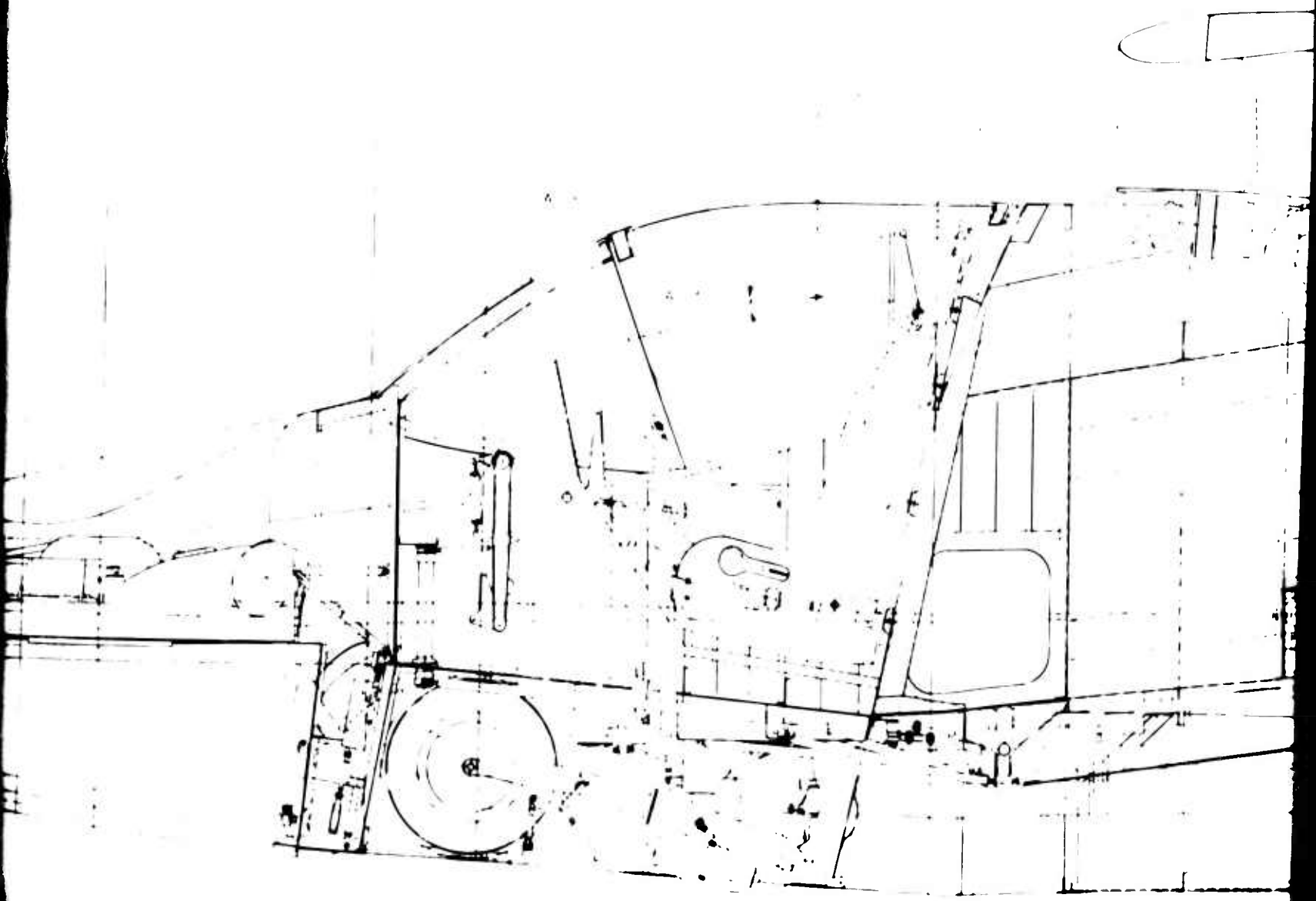

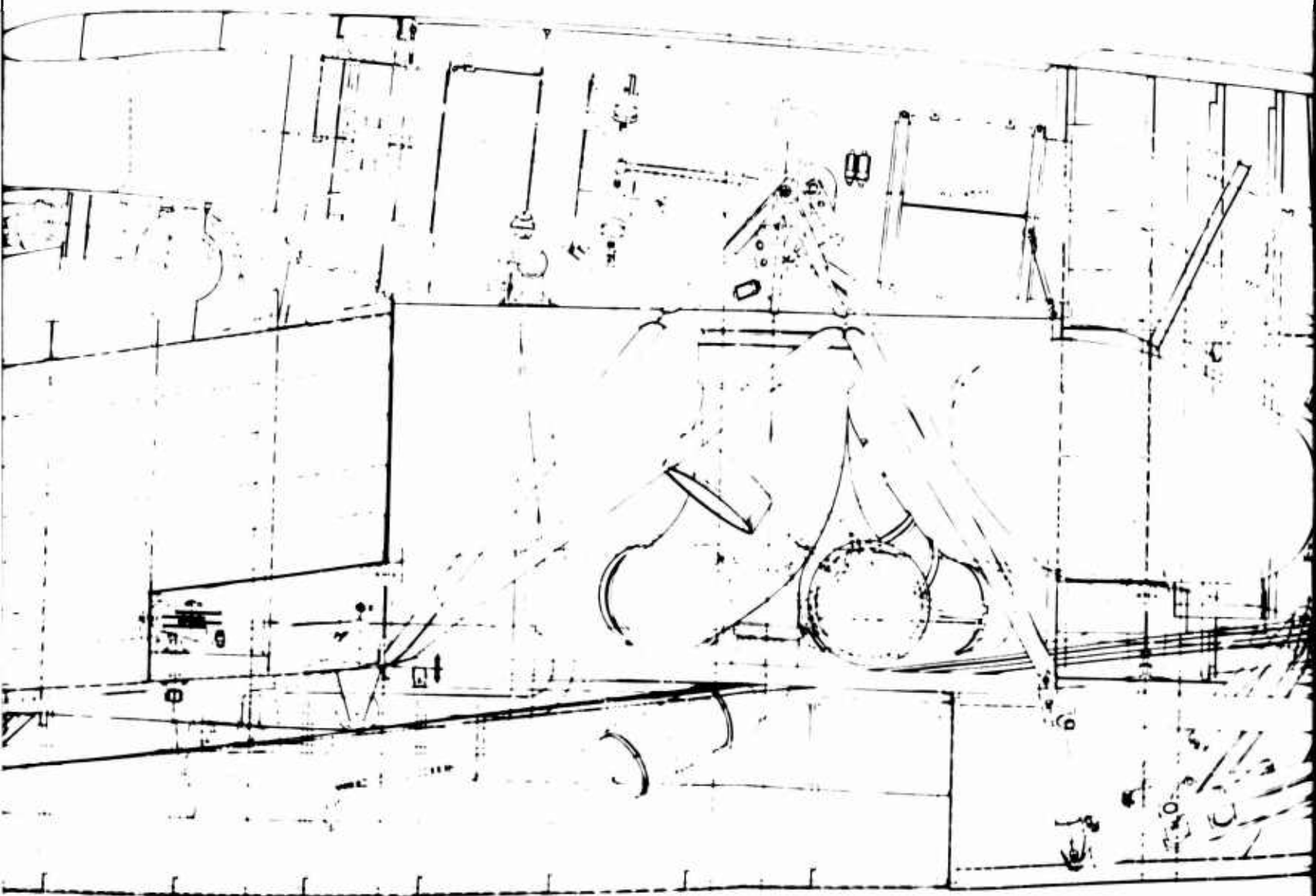

105
106
107

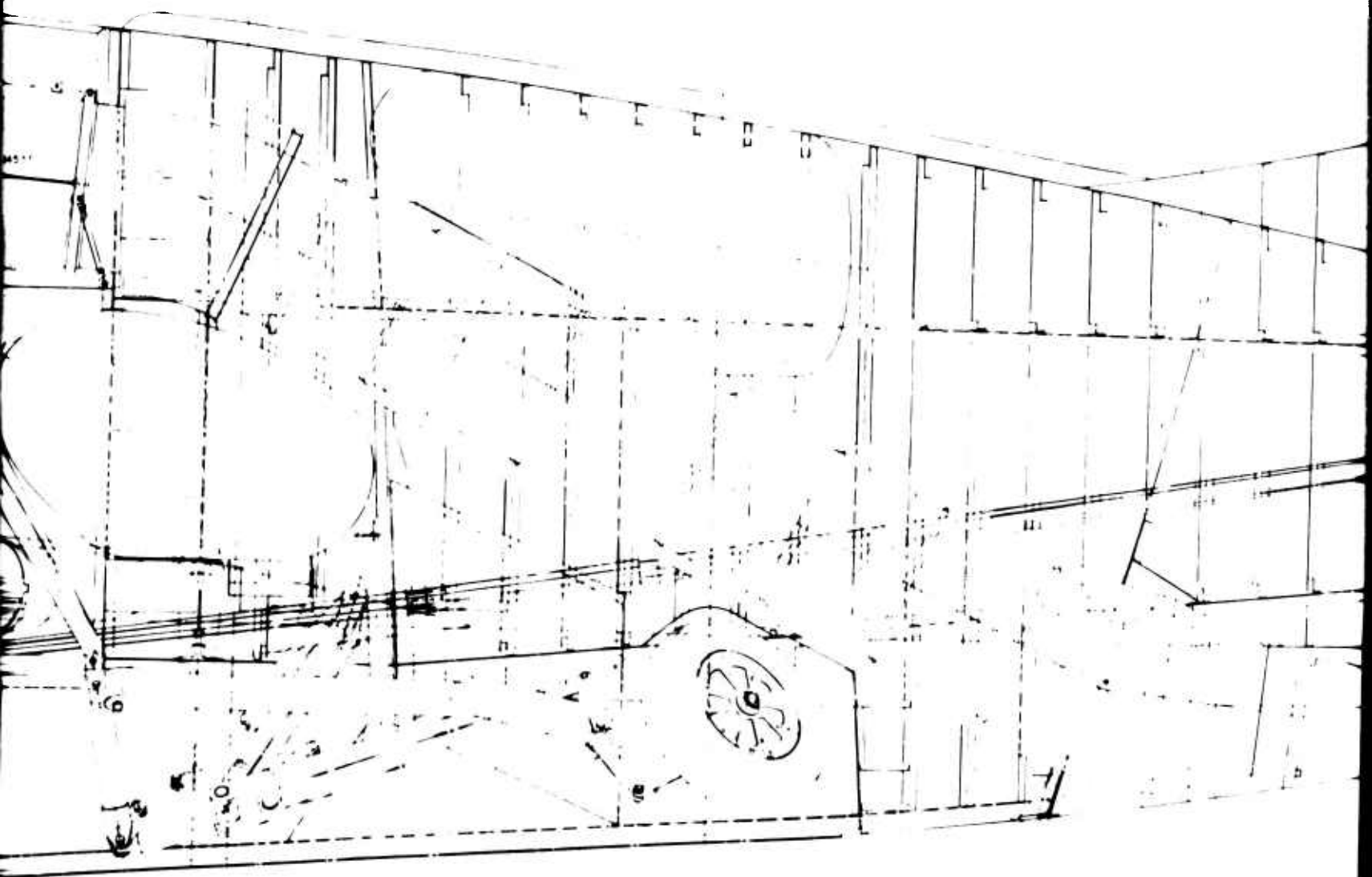

RYAN

REPORT NO. CB148	WEIGHT AND BALANCE REPORT XV-5A	PAGE 165
---------------------	------------------------------------	----------

AIRCRAFT INBOARD PROFILE

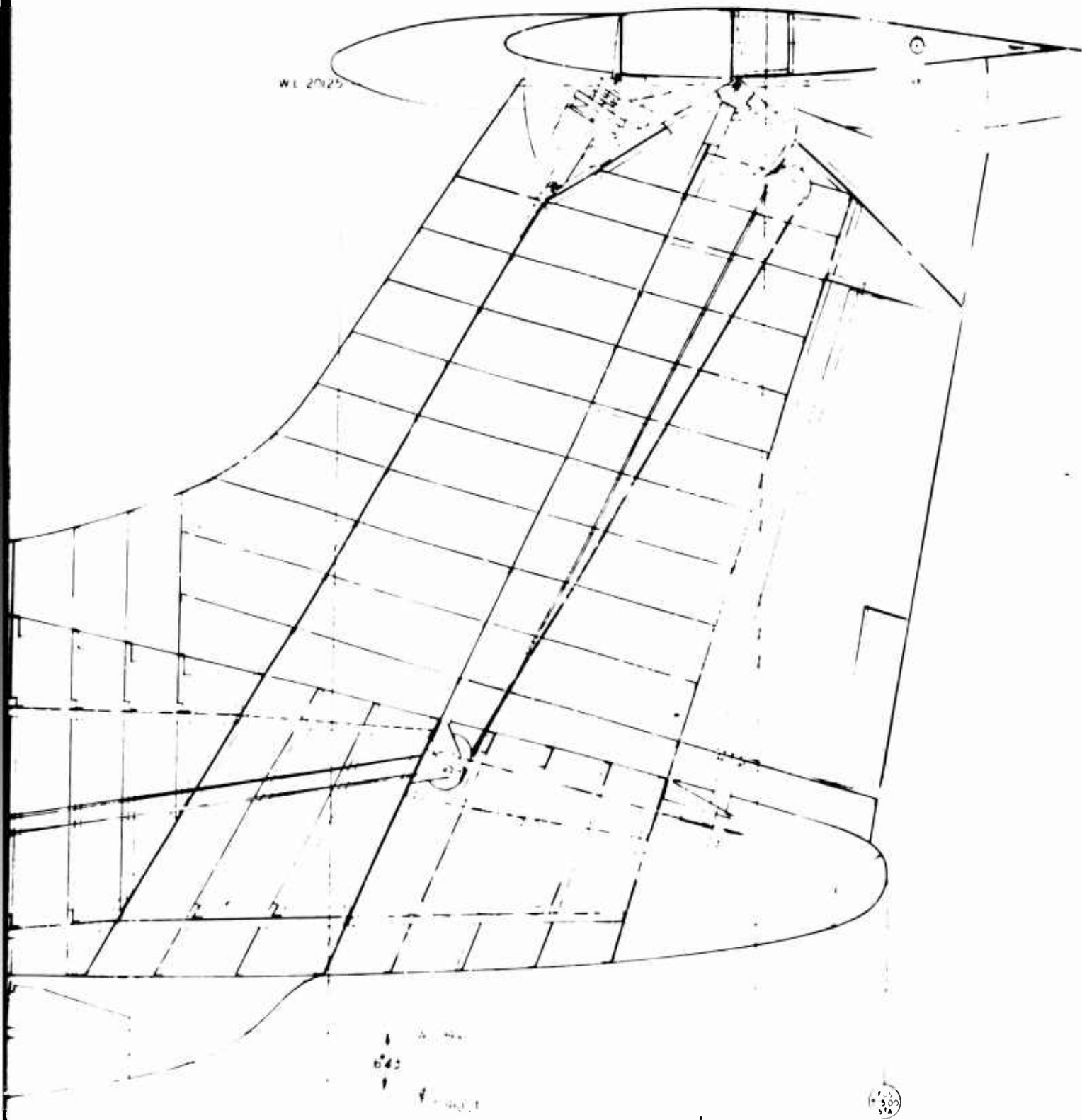

FIGURE 1

RYAN

REPORT NO.
64B148

WEIGHT AND BALANCE REPORT
XV-5A

PAGE 167

FUEL SYSTEM TANK LOCATION DIAGRAM

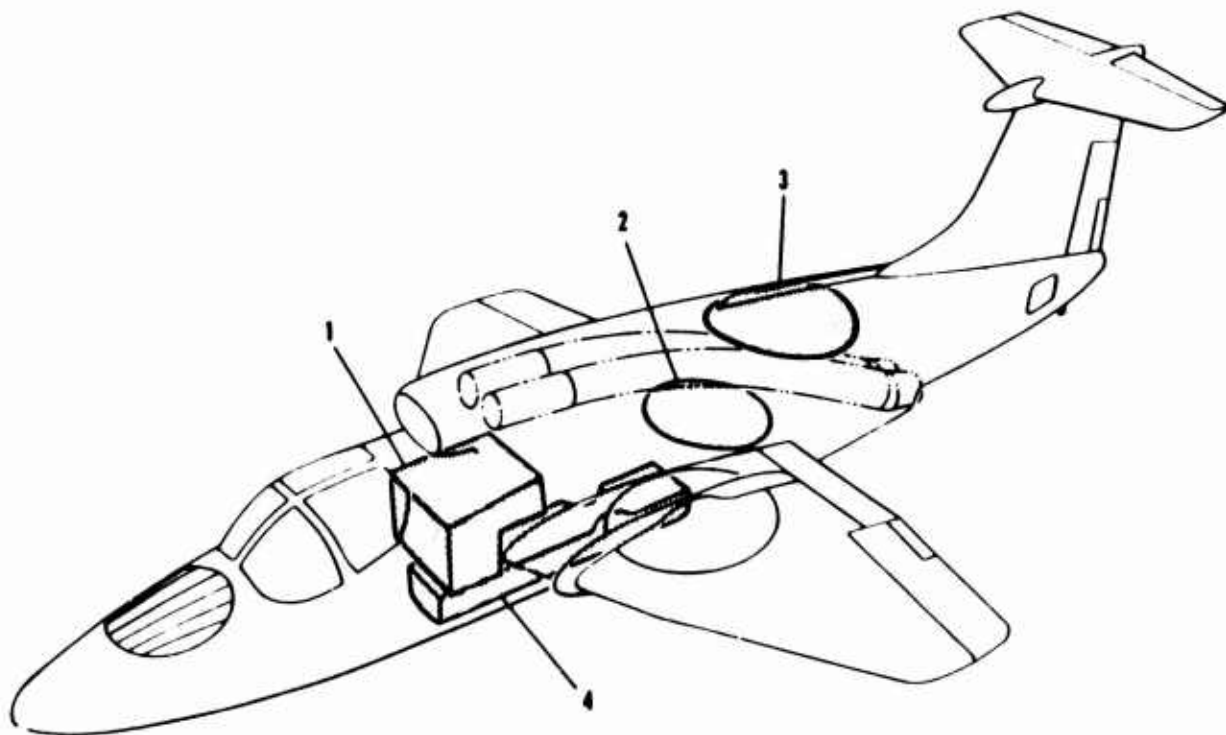

1. Forward Main Fuel Tank
2. Aft Main Fuel Tank
3. Extended Range Dorsal Tank
4. Extended Range Belly Tank

Figure 9

RYAN

REPORT NO. 64B148	WEIGHT AND BALANCE REPORT XV-5A	PAGE 169
----------------------	------------------------------------	----------

4.0 MOMENT OF INERTIA

4.1 Gross Weight Moment of Inertia Summary

RYAN

REPORT NO.
64B148

WEIGHT AND BALANCE REPORT
XV-5A

PAGE 171

SUMMARY OF MOMENT OF INERTIA VALUES

	* CONFIGURATION						
	WEIGHT EMPTY (NO INSTRUMENTATION)	20 MINUTE MISSION	45 MINUTE MISSION	DESIGN GROSS WEIGHT 9200 LBS.	DESIGN GROSS WEIGHT 9200 LBS. (LESS INSTRUMENTATION)	ZERO FUEL INCLUDING AUXILIARY FUEL TANK	FULL FUEL INCLUDING AUXILIARY FUEL TANK
1. WEIGHT (POUNDS)	8081	9972	10873	9200	9200	8883	12093
2. HORIZONTAL C.G. (FUS.STA.)	248.4	240.7	241.6	240.8	245.0	241.5	244.2
3. VERTICAL C.G. (WATERLINE)	113	111	112	111	111	111	113
4. FUEL (POUNDS)	0	1134	2035	362	877	0	3210
5. I_{Y_0} (PITCH) SLUG-FT ²	15450	18441	19288	17764	16732	17339	21172
6. I_{X_0} (ROLL) SLUG-FT ²	4412	4608	4552	4530	4447	4520	4678
7. I_{Z_0} (YAW) SLUG-FT ²	17622	20576	21487	19968	18914	19750	23284
8. I_{XZ} (PRODUCT) SLUG-FT ²	1116	1432	1470	1.97	1213	1.79	1817
9. PRINCIPAL AXIS ANGLE THRU C.G.	4°48'	5°05'	4°55'	4°46'	4°46'	4°46'	5°32'

* NOTE: All conditions include 515 lbs. of standard instrumentation equipment unless otherwise noted.

RYAN



REPORT NO.
04B148

WEIGHT AND BALANCE REPORT
XV-5A

PAGE 173

... Finelage Moment of Inertia

RYAN

REPORT NO.
64B14F

WEIGHT AND BALANCE REPORT
XV-5A

PAGE 175

MASS DISTRIBUTION - FUSELAGE AND CONTENTS - WEIGHT EMPTY

SECTION NUMBER	FUS. STA. BOUNDARIES	WEIGHT	\bar{X}	\bar{Z}	I_y PITCH LB. IN ²	I_x ROLL LB. IN ²	I_z YAW LB. IN ²	I_{xz} PRODUCT LB. IN ²
1	-10 to 0	.42	- 2.2	94.0				
5	0 10	2.34	4.8	93.9				
15	10 20	7.95	16.5	94.0				
25	20 30	2.14	25.2	94.0				
35	30 40	25.17	36.1	91.7				
45	40 50	23.75	44.7	91.1				
55	50 60	40.03	56.0	96.4				
65	60 70	146.66	62.0	98.8				
75	70 80	41.35	76.3	91.0				
85	80 90	54.36	85.7	90.7				
95	90 100	83.65	95.8	98.2				
105	100 110	93.65	105.9	109.4				
115	110 120	102.24	114.6	102.3				
125	120 130	109.32	125.2	95.8				
135	130 140	87.35	134.6	98.8				
145	140 150	227.46	146.9	109.4				
155	150 160	185.62	155.6	104.7				
165	160 170	90.97	165.0	112.0				
175	170 180	109.63	174.2	121.3				
185	180 190	145.36	185.2	127.2				
195	190 200	107.15	194.2	122.4				
205	200 210	77.48	205.0	116.2				
* 215	210 220	875.42	215.4	140.2				
225	220 230	82.44	224.7	109.7				
235	230 240	62.65	234.2	114.8				
245	240 250	85.77	243.9	118.0				
** 255	250 260	387.45	256.1	133.9				
265	260 270	63.32	264.2	115.6				
275	270 280	68.46	275.8	119.8				
285	280 290	169.98	285.5	112.5				
295	290 300	114.20	295.3	107.3				
305	300 310	141.71	304.6	100.4				
315	310 320	145.73	314.7	101.9				
325	320 330	98.54	324.8	101.4				
335	330 340	86.06	334.7	100.7				
345	340 350	61.67	343.9	103.9				
355	350 360	127.02	353.2	97.1				
365	360 370	33.77	365.2	106.0				
375	370 380	36.20	374.3	103.4				
385	380 390	27.41	384.7	105.4				
395	390 400	49.08	394.2	104.9				
405	400 410	31.30	404.2	105.5				
415	410 420	28.49	415.2	105.9				
425	420 430	22.18	424.5	108.3				
435	430 440	20.85	434.7	114.6				
445	440 450	14.16	444.4	109.7				

RYAN

REPORT NO. 04B148	WEIGHT AND BALANCE REPORT XV-5A	PAGE 170
----------------------	------------------------------------	----------

MASS DISTRIBUTION - FUSELAGE AND CONTENTS -
WEIGHT EMPTY (Continued)

SECTION NUMBER	FUS. STA. BOUNDARIES	WEIGHT	\bar{X}	\bar{Z}	I_y PITCH LB. IN ²	I_x ROLL LB. IN ²	I_z YAW LB. IN ²	I_{xz} PRODUCT LB. IN ²
455	450 to 460	45.29	455.0	112.1				
465	460 470	10.95	465.5	114.3				
475	470 480	34.19	472.7	110.4				
485	480 490	15.38	485.7	110.3				
495	490 500	7.73	494.8	111.0				
505	500 510	9.39	504.0	110.5				
515	510 520	4.70	512.8	113.9				
TOTAL		4745.80	227.8	115.5	40533261	5004000	44000372	491043

* INCLUDES FORWARD ENGINE REACTION OF 695.05 at Sta. 215.38

** INCLUDES AFT ENGINE REACTION OF 217.57 Lbs. at Sta. 257.1

RYAN

REPORT NO.
64B148

WEIGHT AND BALANCE REPORT
XV-5A

PAGE 177

MASS DISTRIBUTION - FUSELAGE BASIC STRUCTURE *

SECTION NUMBER	FUS. STA. BOUNDARIES	WEIGHT	\bar{X}	\bar{Z}
1	-10 to 0	.42	- 2.2	94.0
5	0 10	2.33	4.8	93.9
15	10 20	7.95	16.5	94.0
25	20 30	2.14	25.2	94.0
35	30 40	10.15	35.5	95.4
45	40 50	3.97	45.0	97.8
55	50 60	6.31	56.3	98.5
65	60 70	7.26	64.8	98.2
75	70 80	14.99	77.5	90.7
85	80 90	18.92	84.8	91.4
95	90 100	16.79	92.6	98.1
105	100 110	11.76	104.3	92.7
115	110 120	18.11	113.8	88.6
125	120 130	13.03	124.6	92.4
135	130 140	16.63	134.9	90.5
145	140 150	45.76	146.5	102.3
155	150 160	34.31	155.6	112.5
165	160 170	32.64	164.6	105.8
175	170 180	25.06	175.3	102.1
185	180 190	28.41	186.6	103.0
195	190 200	24.95	194.5	103.2
205	200 210	32.69	205.1	112.2
215	210 220	100.59	214.4	111.7
225	220 230	35.65	224.8	109.3
235	230 240	32.49	235.2	111.5
245	240 250	34.12	244.5	121.7
255	250 260	38.79	255.3	124.6
265	260 270	42.69	264.0	113.9
275	270 280	35.99	275.8	109.8
285	280 290	80.79	285.9	116.8
295	290 300	61.87	295.4	107.1
305	300 310	29.46	305.2	112.5
315	310 320	59.38	315.9	106.4
325	320 330	29.23	325.1	109.2
335	330 340	24.78	334.5	106.8
345	340 350	20.58	343.6	116.1
355	350 360	15.33	354.7	115.0
365	360 370	16.99	365.5	110.4
375	370 380	14.45	374.5	112.8
385	380 390	15.27	385.4	111.2
395	390 400	25.19	394.4	114.1
405	400 410	11.18	404.7	121.9
415	410 420	15.12	415.2	114.7
425	420 430	13.54	424.5	115.2
435	430 440	15.31	435.0	118.2
445	440 450	11.67	444.7	111.3

* Does not include canopy, windshield, main landing gear door or nose landing gear door.

RYAN



REPORT NO. 64B148	WEIGHT AND BALANCE REPORT XV-5A	PAGE 178
----------------------	------------------------------------	----------

MASS DISTRIBUTION - FUSELAGE BASIC STRUCTURE (Continued)

SECTION NUMBER	FUS. STA. BOUNDARIES	WEIGHT	\bar{X}	\bar{Z}	I _y PITCH LB. IN ²	I _x ROLL LB. IN ²	I _z YAW LB. IN ²	I _{yz} PRODUCT LB. IN ²
455	450 to 460	17.34	455.3	114.1				
465	460 470	8.33	465.4	112.4				
475	470 480	12.26	473.9	108.7				
485	480 490	15.15	485.7	110.3				
495	490 500	7.62	494.8	110.9				
505	500 510	9.33	504.6	110.3				
515	510 520	3.63	513.8	113.5				
TOTAL		128.70	259.5	109.1	16719713	830231	16920.40	028317

RYAN

REPORT NO.
9-B118

WEIGHT AND BALANCE REPORT
XV-5A

PAGE 179

4.3 Wing Moment of Inertia

○ PART I TYPE 1

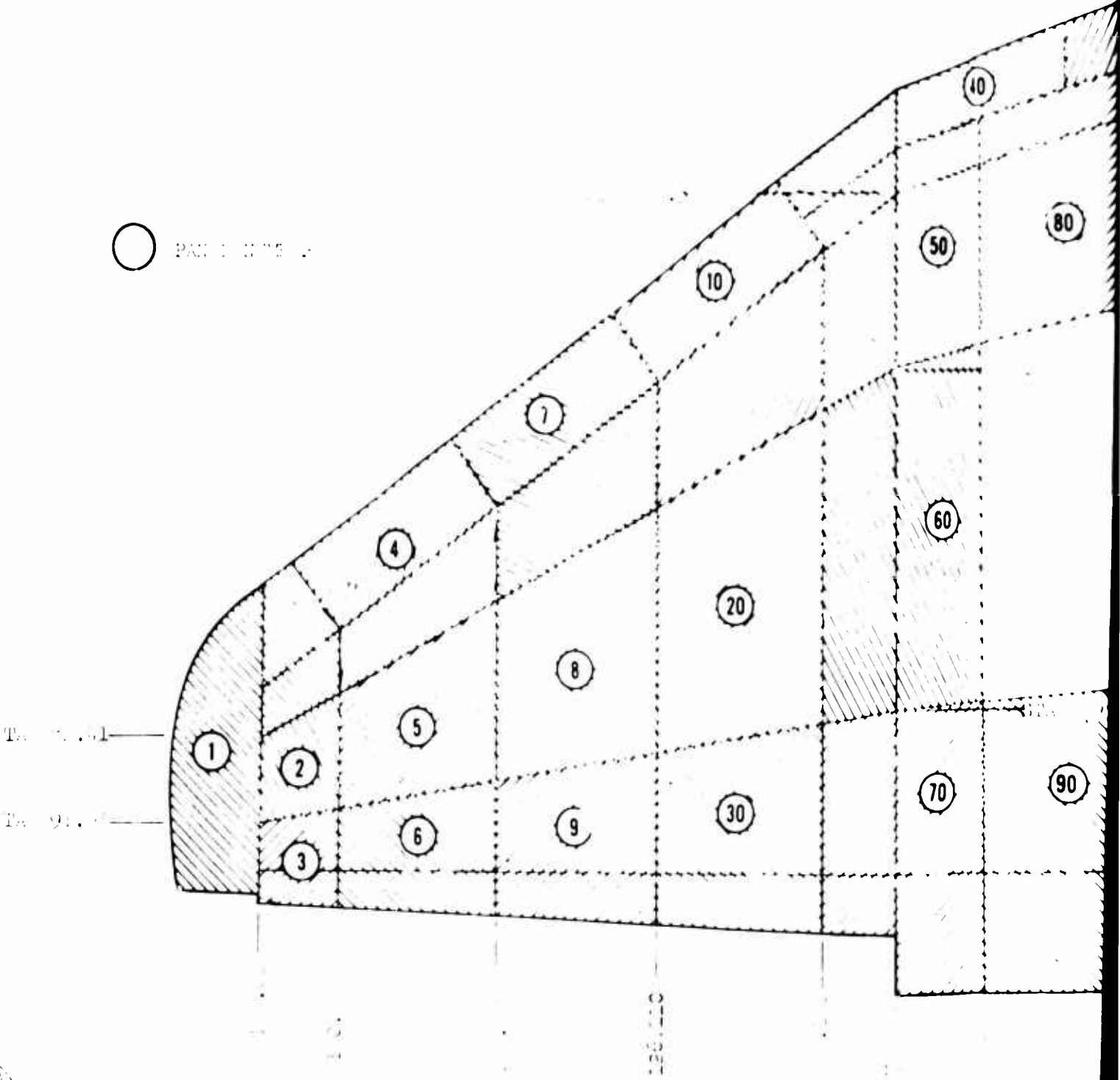

Part I

Part II

A

RYAN

1. POINT NO.

1000 - 11 - 1 - 1 - 1 - 1 - 1 - 1

PAGE 1

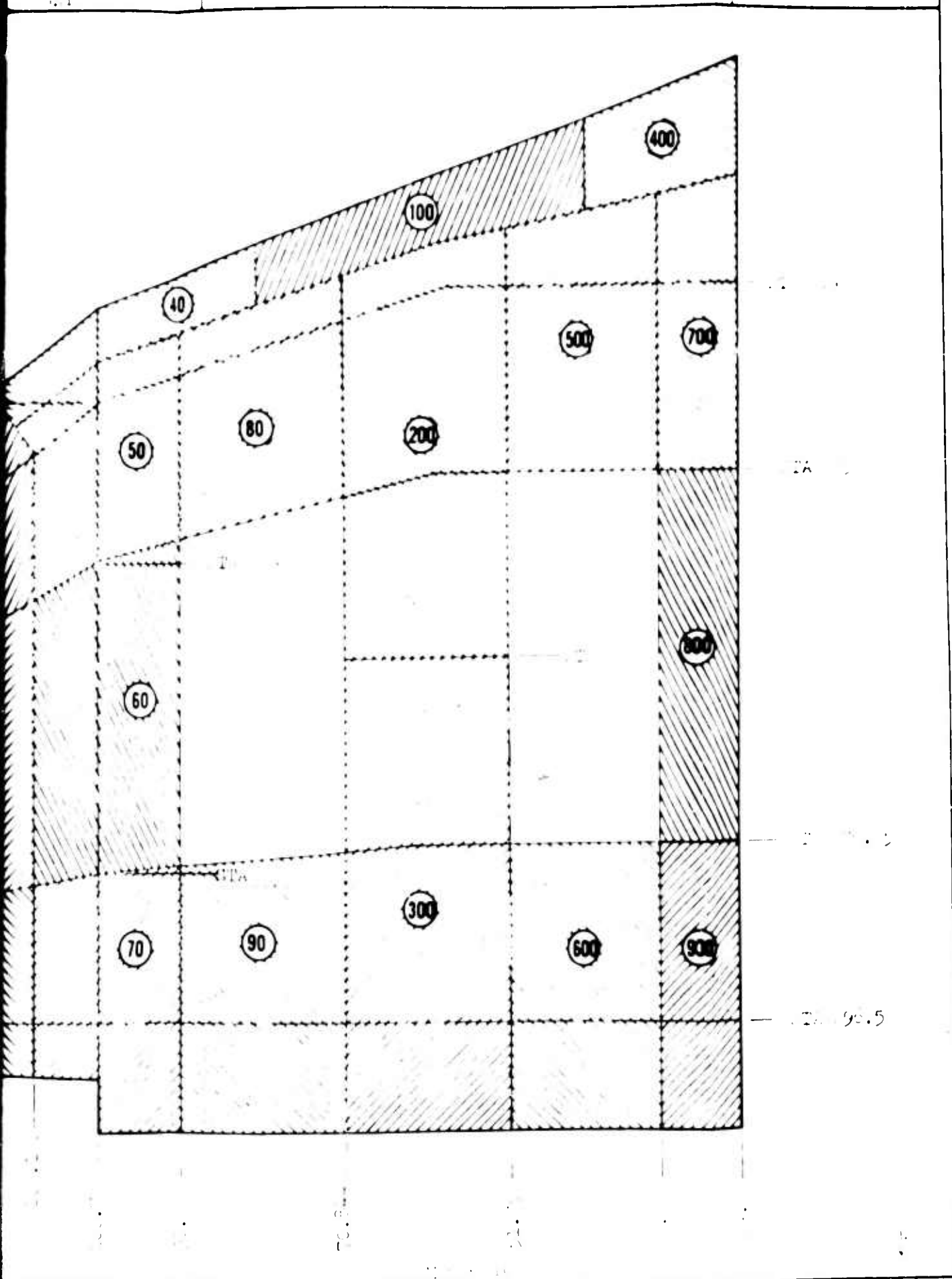

RYAN

REPORT NO.
64B148

WEIGHT AND BALANCE REPORT
XV-5A

PAGE 183

WING AND CONTENTS - EXCLUDING FLAP AND AILERON
DATA SHOWN FOR $1/2$ WING

LIFT FAN AND MOVEABLE PORTION OF
FAN DOORS ARE TREATED AS SEPARATE UNITS

WEIGHT PANEL NUMBER *	WEIGHT POUNDS	\bar{X} HORIZ. C.G. FUS. STA.	\bar{Z} VERT. C.G. WATERLINE	\bar{Y} SPAN C. G. BUTTOCK LINE	I_y PITCH LB. IN ²	I_x ROLL LB. IN ²	I_z YAW LB. IN ²
1	7.58	274.4	104.3	168.7			
2	1.61	285.7	105.2	165.5			
3	1.76	295.7	105.4	165.2			
4	4.15	264.6	104.0	152.7			
5	2.68	282.0	104.5	152.0			
6	3.32	296.3	105.0	151.6			
7	6.29	252.8	103.3	135.8			
8	5.13	274.1	103.7	136.0			
9	6.62	293.8	102.8	133.7			
10	12.18	239.8	101.9	117.2			
20	10.58	268.4	101.5	119.4			
30	19.32	295.1	101.8	120.7			
40	4.80	219.4	101.5	98.3			
50	24.37	230.5	100.9	100.6			
60	17.94	262.3	101.4	101.3			
70	24.84	294.0	100.1	101.6			
80	17.56	221.4	100.5	80.7			
90	18.72	294.9	100.8	81.4			
100	16.17	206.2	100.5	60.7			
200	71.43	226.2	103.3	59.4			
300	67.58	288.0	102.7	60.6			
400	9.21	195.1	100.5	30.8			
500	23.53	215.4	100.8	41.8			
600	23.43	296.9	100.5	41.0			
700	19.98	216.6	100.5	27.8			
800	4.68	255.7	102.8	26.0			
900	26.16	295.0	100.1	28.0			
DOORS	88.01	255.8	110.4	61.0			
SUB TOTAL	539.63	257.4	103.2	73.0	617105.5	639749.4	1220766.0
FAN	864.85	256.0	101.0	56.0	434970.0	496767.0	668922.0
TOTAL	1404.48	256.5	101.8	62.5	1056205.4	1232239.7	1987333.9

* See Fig. 10

AILERON
MASS PANELS

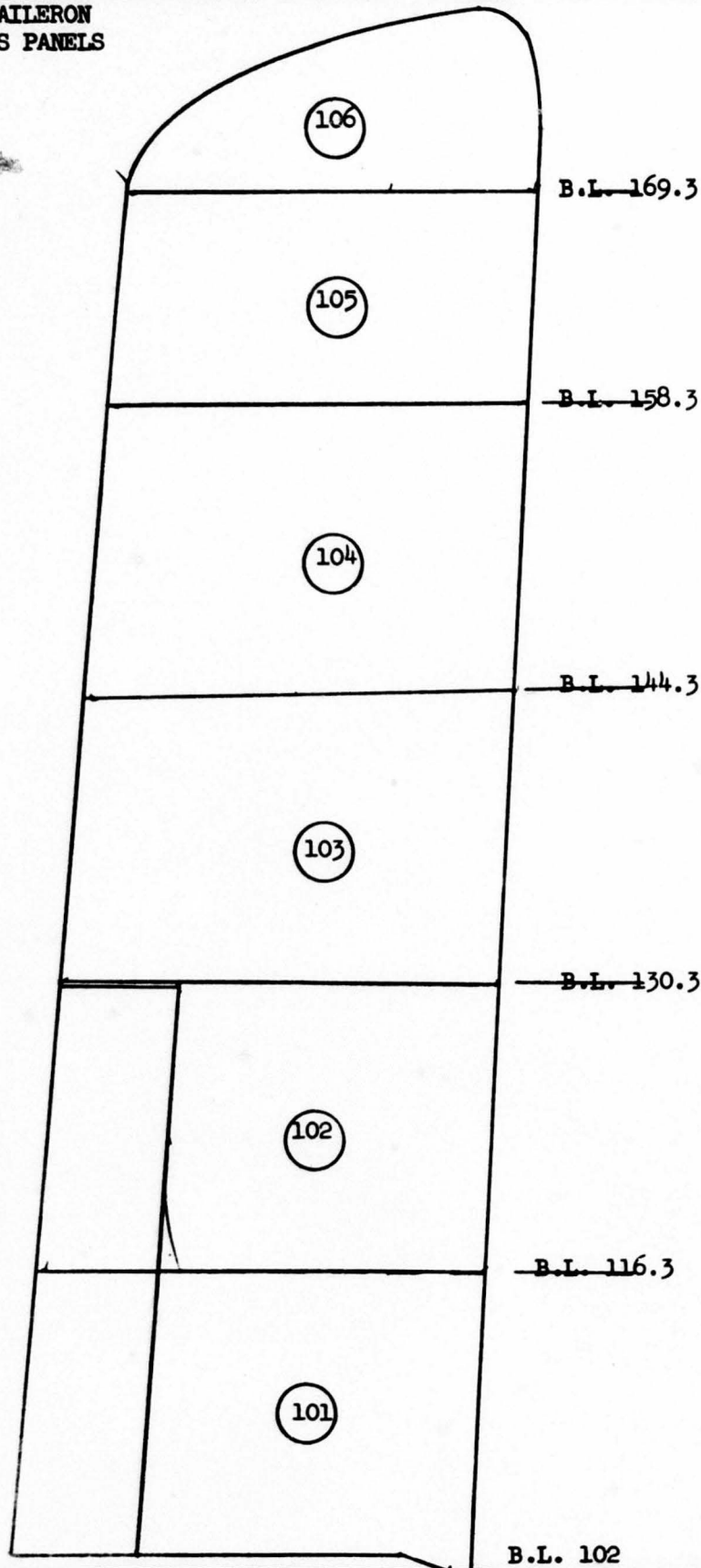

AILERON AND FLIGHT TAB MASS PROPERTIES AND MOMENTS OF INERTIA

AILERON AND FLIGHT TAB MASS PROPERTIES AND MOMENTS OF INERTIA
DATA FOR ONE SIDE ONLY

PANEL BOUNDARIES ARE BUTTOCK LINES PARALLEL TO CENTER LINE OF AIRPLANE

PANEL NO. *	PANEL BOUNDARIES BUTT. LINE	WEIGHT POUNDS	\bar{X} PANEL C.G. FJS. STA.	\bar{Z} PANEL C.G. WATERLINE	\bar{Y} SPAN C.G. BUTT. LINE	I_y PITCH LB. IN ²	I_x ROLL LB. IN ²	I_z YAW LB. IN ²	I_{xz} PRODUCT LB. IN ²	I_{xy} PRODUCT LB. IN ²	I_{yz} PRODUCT LB. IN ²
AILERON WITH FLIGHT TAB AND BALANCE WEIGHTS											
101	102-116.3	5.850	312.27	101.52	108.24	302.7	74.0	355.4	- 13.8	11.1	11.4
102	116.3-130.3	11.995	311.14	102.59	124.39	512.6	84.5	558.3	- 30.5	- 17.8	23.6
103	130.3-144.3	2.590	306.44	103.62	136.89	111.9	52.6	141.3	- 0.5	0.2	15.4
104	144.3-158.3	2.085	306.25	104.60	151.59	90.0	34.9	105.2	0.4	0.5	14.3
105	158.3-169.3	2.525	305.81	105.17	165.84	73.0	37.6	91.2	- 1.6	- 1.1	15.3
106	169.3-TIP	.995	306.74	105.82	172.79	29.4	6.7	31.2	- 0.4	0.9	1.1
TOTAL		26.040	309.85	102.99	130.05	1323.0	9637.3	10750.9	- 122.1	- 1124.5	129.9
AILERON LESS FLIGHT TAB AND BALANCE WEIGHTS											
101	102-116.3	3.470	307.67	101.83	107.67	115.0	57.8	153.4	- 2.2	- 6.3	10.3
102	116.3-130.3	7.820	307.34	102.88	124.71	179.3	54.4	199.1	- 5.4	- 6.3	20.9
103	130.3-144.3	2.590	306.44	103.62	136.89	111.9	52.7	141.3	- 0.5	0.2	15.4
104	144.3-158.3	2.085	306.25	104.60	151.59	90.0	34.9	105.2	0.4	0.5	14.3
105	158.3-169.3	2.525	305.81	105.17	165.84	73.0	37.6	91.2	- 1.6	- 1.1	15.3
106	169.3-TIP	.995	306.74	105.82	172.79	29.4	6.7	31.2	- 0.4	0.9	1.1
TOTAL		19.485	306.93	103.42	133.96	634.1	8074.2	8532.0	- 22.8	- 224.8	111.8
AILERON FLIGHT TAB WITH BALANCE WEIGHTS											
101	102-116.3	2.380	318.98	101.08	109.07	6.4	12.7	18.7	0.3	- 4.8	.2
102	116.3-TIP	4.175	318.28	102.04	123.80	5.6	25.8	31.0	0.1	3.1	.3
TOTAL		6.555	318.53	101.69	118.45	14.1	368.9	379.5	- 0.6	- 17.5	2.1
FLIGHT TAB BALANCE WEIGHTS											
101	102-116.3	1.39	317.8	101.0	110.0						
102	116.3-TIP	1.11	316.7	102.0	121.8						
TOTAL		2.50	317.3	101.5	115.2						

* See Fig. 11

FLAP
MASS PANELS

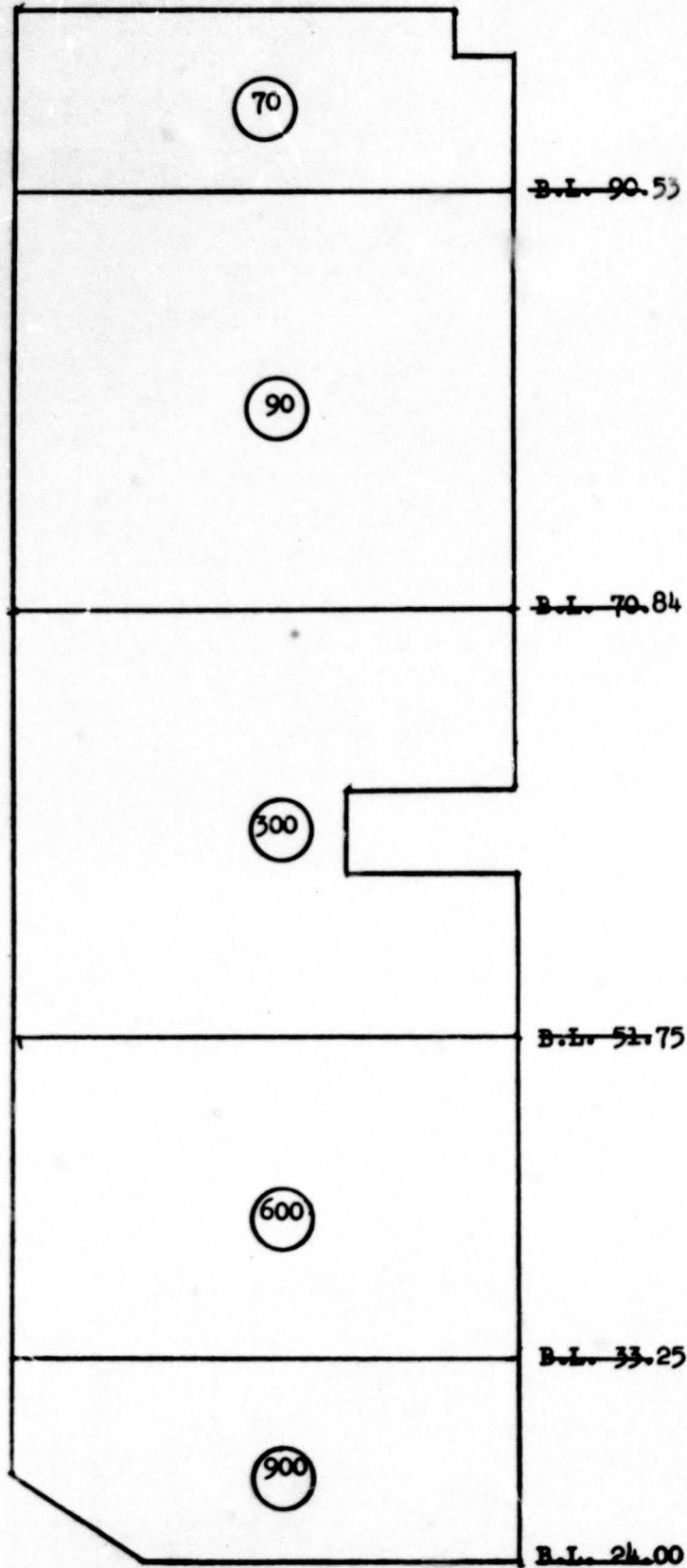

Fig. 12

RYAN

REPORT NO.
64B148

WEIGHT AND BALANCE REPORT
XV-5A

PAGE 187

MOMENTS OF INERTIA - FLAP
DATA SHOWN FOR ONE SIDE ONLY

WEIGHT PANEL NUMBER * WEIGHT POUNDS	\bar{X} HORIZ. C.G. FUS STA	\bar{Z} VERT. C.G. WATER LINE	\bar{Y} SPAN C.G. BUTT LINE	I_y PITCH ² LB. IN ²	I_x ROLL ² LB. IN ²	I_z YAW ² LB. IN ²	I_{xz} PRODUCT LB. IN ²	I_{xy} PRODUCT LB. IN ²	I_{yz} PRODUCT LB. IN ²
70	4.210	312.06	96.99	55.7	27.4	76.9	4.9	-20.0	3.0
90	6.355	312.69	81.02	67.2	61.7	120.1	1.4	1.3	3.5
300	7.290	312.81	60.68	97.9	157.1	241.3	4.4	-22.9	4.2
600	8.675	312.72	43.19	84.2	68.3	142.6	2.1	- 0.6	2.1
900	8.515	310.00	27.68	97.3	38.1	113.6	9.8	15.0	3.0
TOTAL	35.045	312.00	56.38	449.2	19812.0	20199.2	25.1	522.4	17.5

* See Fig. 12

REPORT NO.
64B143

WEIGHT AND BALANCE REPORT
XV-5A

PAGE 189

4.4 Horizontal Tail Moment of Inertia

HORIZONTAL STABILIZER
MASS PANELS

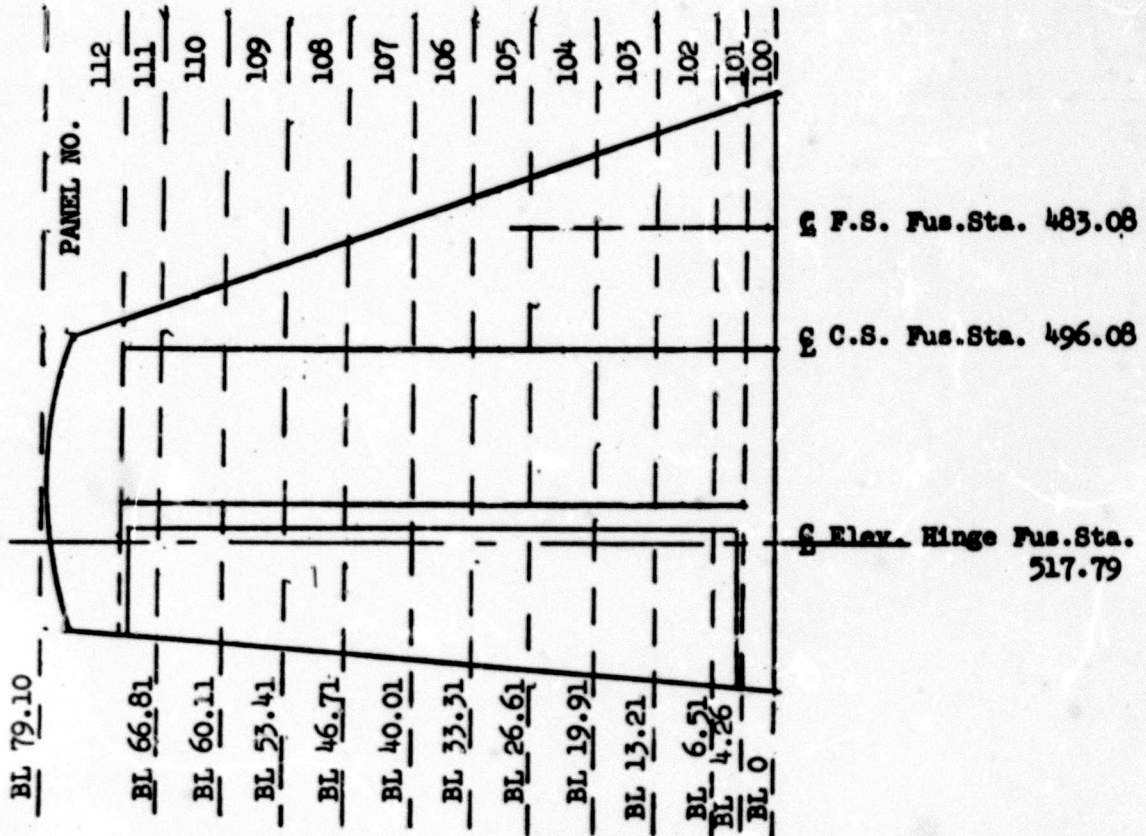

SYMBOL	DEFINITION
\bar{X}	HORIZONTAL CENTER OF GRAVITY OF ITEM
\bar{Y}	SPANWISE CENTER OF GRAVITY OF ITEM
\bar{Z}	VERTICAL CENTER OF GRAVITY OF ITEM
I_x	MOMENT OF INERTIA ABOUT HORIZONTAL AXIS WITH RESPECT TO ITEM CENTER OF GRAVITY
I_y	MOMENT OF INERTIA ABOUT SPANWISE AXIS WITH RESPECT TO ITEM CENTER OF GRAVITY
I_z	MOMENT OF INERTIA ABOUT VERTICAL AXIS WITH RESPECT TO ITEM CENTER OF GRAVITY
I_{xz}	PRODUCT OF INERTIA IN HORIZONTAL-VERTICAL PLANE WITH RESPECT TO ITEM CENTER OF GRAVITY
I_{xy}	PRODUCT OF INERTIA IN HORIZONTAL-SPANWISE PLANE WITH RESPECT TO ITEM CENTER OF GRAVITY
I_{yz}	PRODUCT OF INERTIA IN SPANWISE-VERTICAL PLANE WITH RESPECT TO ITEM CENTER OF GRAVITY

Fig. 13

* HORIZONTAL STABILIZER AND ELEVATOR MASS DISTRIBUTION AND MOMENTS OF INERTIA
DATA FOR ONE SIDE ONLY

PANEL BOUNDARIES ARE BUTTOCK LINES PARALLEL TO CENTER LINE OF AIRFRAME

PANEL NO. **	PANEL BOUNDARIES BUTT. LINE	WEIGHT ONE SIDE POUNDS	\bar{X} PANEL C.G. FUS STA	\bar{Y} PANEL C.G. BUTT. WATER LINE	\bar{Z} PANEL C.G. WATER LINE	I_y FITCH ² LB. IN ²	I_x ROLL ² LB. IN ²	I_z YAW ² LB. IN ²	I_{xz} PRODUCT LB. IN ²	I_{xy} PRODUCT LB. IN ²	I_{yz} PRODUCT LB. IN ²
HORIZONTAL STABILIZER (EXCLUDING ELEVATOR)											
100	0-4.26	24.68	487.93	0.71	198.38	17490.8	1018.2	16800.4	2938.1	196.1	3.0
101	4.26-6.51	1.01	495.25	5.02	205.99	146.4	6.3	140.6	- 0.2	0.3	0.1
102	6.51-13.21	3.66	495.71	10.00	205.85	525.7	23.1	515.4	- 2.2	0	0.6
103	13.21-19.91	3.39	496.57	17.00	206.00	454.3	23.2	443.2	0.5	0	1.1
104	19.91-26.61	3.18	497.43	23.00	205.99	408.5	22.2	397.7	0	0	1.4
105	26.61-33.31	3.23	498.00	30.05	206.00	359.0	21.0	351.5	- 0.2	1.7	1.6
106	33.31-40.01	2.94	503.29	36.94	206.00	294.1	11.3	294.1	- 0.1	0.7	0.8
107	40.01-46.71	2.20	502.22	43.00	206.00	184.9	10.7	183.5	0	0	0.9
108	46.71-53.41	2.07	503.04	50.00	206.00	157.6	9.8	156.7	0	0	0.9
109	53.41-60.11	1.88	503.90	57.00	206.00	128.1	8.9	127.4	0	0	1.1
110	60.11-66.81	1.77	504.89	63.03	206.00	106.3	8.0	106.0	0.1	- 0.1	1.1
111	66.81-69.91	.83	507.04	68.41	206.00	52.9	2.6	52.0	0	2.2	0.6
112	69.91-79.10	3.14	510.32	72.43	206.00	229.4	20.9	232.5	0	- 2.5	0
TOTAL STAB.		53.94	495.00	20.31	202.50	24250.8	32398.5	53159.5	4265.2	9289.8	169.7
ELEVATOR											
101	4.25-6.51	2.04	518.10	3.63	205.91	24.2	11.1	34.2	0	- 0.2	0
102	6.51-13.21	2.87	517.74	9.07	206.00	60.6	10.2	69.0	0	2.7	0
103	13.21-19.91	1.95	517.76	17.00	206.00	50.9	7.2	56.6	0	0	0
104	19.91-26.61	1.85	517.69	23.37	206.00	44.4	7.4	50.4	0	- 1.2	0
105	26.61-33.31	1.74	517.79	29.97	206.00	38.6	7.1	44.6	0	0.1	0.1
106	33.31-40.01	2.11	518.03	36.95	206.12	33.9	7.1	38.9	- 0.3	0.4	0.2
107	40.01-46.71	1.63	517.81	43.24	206.00	29.8	5.9	34.6	0	- 1.0	0.1

* Includes structure, controls, electrical wiring, etc.

** See Fig. 13

* HORIZONTAL STABILIZER AND ELEVATOR MASS DISTRIBUTION AND MOMENTS OF INERTIA
DATA FOR ONE SIDE ONLY

PANEL BOUNDARIES ARE BUTTOCK LINES PARALLEL TO CENTER LINE OF AIRPLANE

PANEL NO. **	PANEL BOUNDARIES BUTT. LINE	WEIGHT ONE SIDE POUNDS	\bar{X} PANEL C.G. FUS STA	\bar{Y} PANEL C.G. BUTT. LINE	\bar{Z} PANEL C.G. WATER LINE	I_y PITCH ² LB. IN ²	I_x ROLL ² LB. IN ²	I_z YAW ² LB. IN ²	I_{xz} PRODUCT LB. IN ²	I_{xy} PRODUCT LB. IN ²	I_{yz} PRODUCT LB. IN ²
<u>ELEVATOR (Continued)</u>											
108	46.71-53.41	1.65	517.66	50.00	206.00	26.6	6.0	31.5	0	0	0
109	53.41-60.11	1.44	517.87	56.94	206.00	22.8	5.2	27.0	0	- 0.2	0.1
110	60.11-66.81	1.46	517.80	63.15	206.00	20.1	5.1	24.2	0	- 0.5	0.1
111	66.81-69.91	.98	518.03	67.29	206.00	9.2	1.4	10.1	0	0.1	0.1
TOTAL		19.69	517.84	52.27	206.00	361.3	8142.5	8490.2	- 0.4	- 1.5	0.8
<u>STABILIZER AND ELEVATOR</u>											
100	0-4.26	24.68	487.93	0.71	198.38	17490.8	1018.2	16800.4	2938.1	196.1	3.0
101	4.26-6.51	3.04	510.54	4.09	205.93	521.8	18.8	527.3	- 1.4	- 21.2	0.1
102	6.51-13.21	6.52	505.39	9.85	205.91	1366.3	33.5	1364.5	3.0	- 9.0	0.6
103	13.21-19.91	5.33	504.31	17.00	206.00	1060.6	30.4	1055.2	0.4	0	0
104	19.91-26.61	5.02	504.88	23.14	206.00	931.9	29.8	927.3	0	7.5	1.5
105	26.61-33.31	4.97	504.93	30.02	206.00	840.4	28.1	838.9	- 0.2	0.2	1.7
106	33.31-40.01	5.04	509.44	36.95	206.05	594.4	18.4	599.4	1.8	1.2	0.9
107	40.01-46.71	3.82	508.86	43.10	206.00	442.1	16.7	445.6	0	2.5	1.0
108	46.71-53.41	3.71	509.52	50.00	206.00	379.9	15.8	383.9	0	0	1.0
109	53.41-60.11	3.31	509.97	56.98	206.00	309.8	14.1	313.3	0	- 0.8	1.2
110	60.11-66.81	3.23	510.73	63.09	206.00	259.6	13.1	263.4	0	0.6	1.2
111	66.81-69.91	1.81	512.99	68.55	206.00	116.3	4.0	116.5	0	3.6	0.6
112	69.91-79.10	3.14	510.32	72.43	206.00	229.4	20.9	232.5	0	- 2.6	0
TOTAL		73.63	501.11	23.51	203.44	62289.8	42761.0	71234.3	5417.1	15227.9	216.5

* Includes structure, controls, electrical wiring, etc.

** See Fig. 13

HORIZONTAL STABILIZER AND ELEVATOR MASS DISTRIBUTION
DATA FOR ONE SIDE ONLY

PANEL BOUNDARIES ARE BUTTOCK LINES PARALLEL TO CENTER LINE OF AIRPLANE

PANEL NO.*	PANEL BOUNDARIES BUTTOCK LINE	WEIGHT ONE SIDE POUNDS	\bar{X} FUS.STA.	\bar{Y} BUTT.LINE	\bar{Z} WATER LINE
BALANCE WEIGHTS					
101	4.26-6.51	.61	514.4	6.0	206
102	6.51-13.21	2.00	514.4	9.4	206
103	13.21-19.91	1.74	514.6	17.0	206
104	19.91-26.61	1.65	514.7	23.7	206
105	26.61-33.31	1.50	514.9	29.9	206
106	33.31-40.01	1.10	515.0	36.7	206
107	40.01-46.71	1.26	515.2	43.6	206
108	46.71-53.41	1.35	515.3	50.0	206
109	53.41-60.11	1.02	515.4	57.0	206
110	60.11-66.81	1.09	515.6	63.4	206
111	66.81-69.91	.45	515.7	68.0	206
TOTAL		6.88	514.9	33.2	206

* See Fig. 13

REPORT NO.
64B148

WEIGHT AND BALANCE REPORT
XV-5A

PAGE 195

4.5 Vertical Tail Moment of Inertia

**VERTICAL STABILIZER
MASS PANELS**

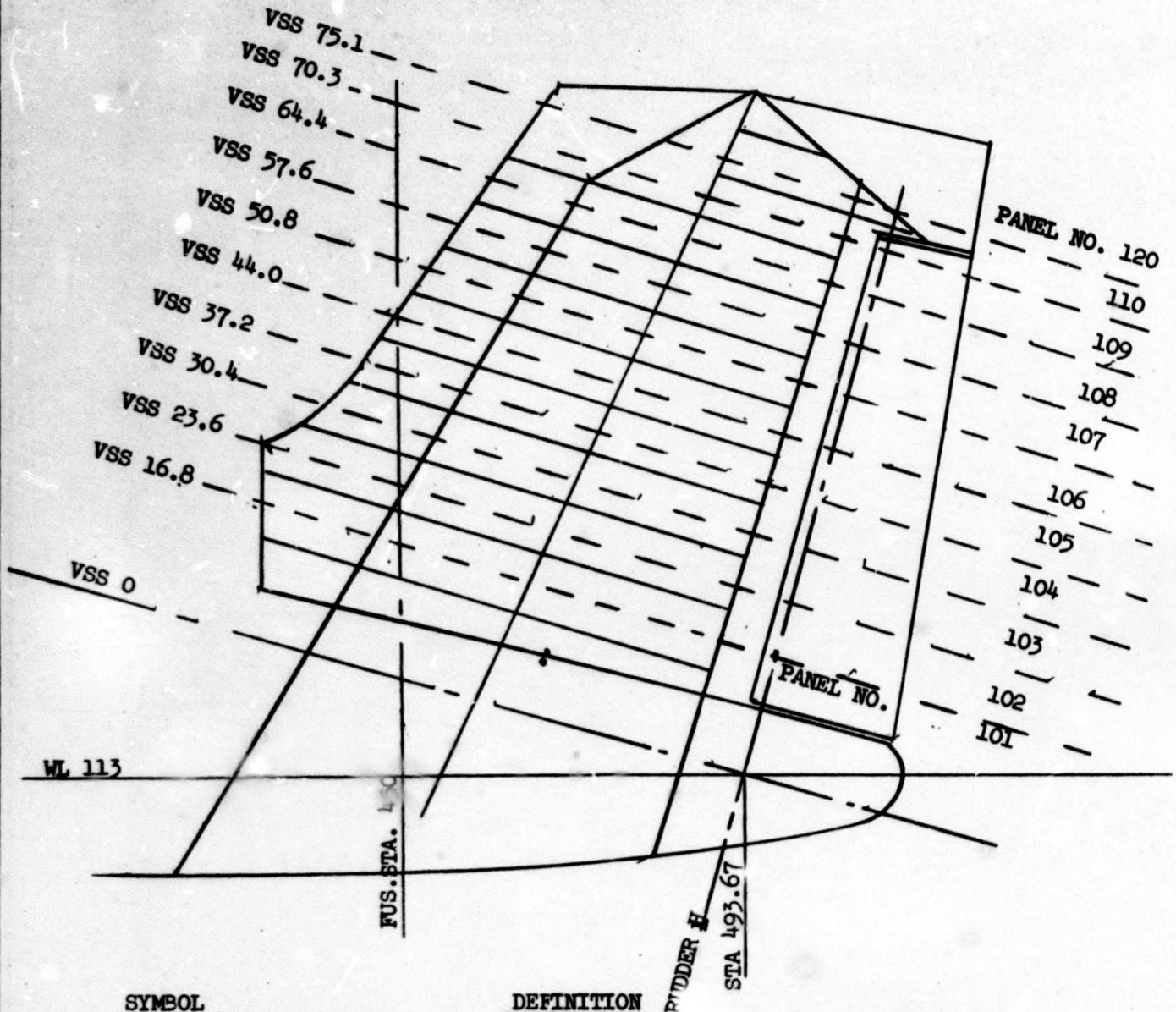

SYMBOL

DEFINITION

\bar{X}	Horizontal center of gravity of item (fuselage station).
\bar{Y}	Longitudinal c.g. of item. Assume to be Buttock Line Zero.
\bar{Z}	Vertical Center of gravity of item (Water Line).
I_x	Moment of inertia about horizontal axis with respect to item c.g.
I_y	Moment of inertia about spanwise axis with respect to item c.g.
I_z	Moment of inertia about vertical axis with respect to item c.g.
I_{xz}	Product of inertia in horizontal-vertical plane with respect to item c.g.

Fig. 14

RYAN

REPORT NO.
64B148

WEIGHT AND BALANCE REPORT
XV-5A

PAGE 197

VERTICAL STABILIZER AND RUDDER MASS DISTRIBUTION AND MOMENTS OF INERTIA

PANEL BOUNDARIES ARE VERTICAL STABILIZER STATIONS PERPENDICULAR TO RUDDER
HINGE LINE

PANEL NO.*	PANEL BOUNDARIES STAB. STA.	WEIGHT POUNDS	X̄ PANEL C.G. FUS. STA.	Z̄ PANEL C.G. WATERLINE	I _y PITCH LB. IN ²	I _x ROLL LB. IN ²	I _z YAW LB. IN ²	I _{xz} PRODUCT LB. IN ²
RUDDER INCLUDING BALANCE WEIGHTS								
101	0-16.8	13.67	495.33 *	122.53	694.1	362.2	388.1	- 97.2
102	16.8-23.6	4.48	499.09	132.50	222.0	27.0	207.8	- 39.1
103	23.6-30.4	3.25	500.38	139.43	145.1	25.3	129.8	- 33.6
104	30.4-37.2	3.49	503.57	145.81	200.5	26.1	183.8	- 40.9
105	37.2-44.0	2.99	502.61	152.42	74.4	16.1	67.5	- 10.5
106	44.0-50.8	2.67	504.69	158.98	65.2	11.0	60.7	- 6.1
107	50.8-57.6	1.77	508.04	165.18	48.1	9.3	45.3	- 6.1
108	57.6-64.4	1.71	509.79	172.22	41.8	9.1	38.9	- 5.3
109	64.4-70.3	1.32	511.28	178.11	28.1	6.3	26.7	- 4.6
110	70.3-72.05	.95	513.03	181.61	9.4	1.1	9.7	- 1.2
TOTAL		36.30	500.67	140.64	14954.6	12902.3	2175.3	3271.9
STABILIZER AND RUDDER								
101	0-16.8	25.67	482.11	127.18	10812.3	1580.8	9622.3	-2854.4
102	16.8-23.6	12.07	478.37	138.15	5626.2	545.7	5567.1	-1347.9
103	23.6-30.4	10.75	478.80	145.30	4670.6	445.3	4468.2	-1068.4
104	30.4-37.2	13.36	475.99	152.96	6512.5	555.7	6179.1	-1526.0
105	37.2-44.0	10.68	482.75	158.32	3793.8	394.2	3608.8	- 811.9
106	44.0-50.8	8.81	485.66	164.08	2874.1	277.4	2778.5	- 617.9
107	50.8-57.6	8.45	486.96	171.07	2445.9	236.6	2343.2	- 529.5
108	57.6-64.4	8.23	489.05	177.34	2144.7	200.6	2069.3	- 445.4
109	64.4-70.3	9.78	489.27	184.03	2137.8	184.2	2077.2	- 405.6
110	70.3-75.1	12.54	494.09	187.77	2609.6	224.4	2494.6	- 557.2
120	75.1-TOP	31.33	492.31	196.50	4604.6	448.3	4283.9	- 834.1
TOTAL		151.67	485.50	164.10	148326.0	99666.3	50813.5	8064.3

*See Fig. 14

RYAN

REPORT NO.
64B148

WEIGHT AND BALANCE REPORT
XV-5A

PAGE 198

VERTICAL STABILIZER AND RUDDER MASS DISTRIBUTION AND MOMENTS OF INERTIA

PANEL BOUNDARIES ARE VERTICAL STABILIZER STATIONS PERPENDICULAR TO RUDDER HINGE LINE

VERTICAL STABILIZER (EXCLUDING RUDDER)

PANEL NO. *	PANEL BOUNDARIES STAB. STA.	WEIGHT POUNDS	\bar{X} PANEL C.G. FUS. STA.	\bar{Z} PANEL C.G. WATERLINE	I_y PITCH LB. IN ²	I_x ROLL LB. IN ²	I_z YAW LB. IN ²	I_{xz} PRODUCT LB. IN ²
101	0-16.8	12.00	467.04	132.47	4371.6	587.3	4118.9	- 960.2
102	16.8-23.6	7.59	466.14	141.48	2319.4	291.6	2301.5	- 475.5
103	23.6-30.4	7.50	469.45	147.84	2195.0	259.5	2168.3	- 444.7
104	30.4-37.2	9.87	466.23	155.48	2475.8	288.2	2400.6	- 553.4
105	37.2-44.0	7.69	475.03	160.62	1937.1	233.3	1903.8	- 314.5
106	44.0-50.8	6.14	477.39	166.30	1321.8	166.8	1330.2	- 240.3
107	50.8-57.6	6.68	481.38	172.63	1325.5	149.7	1303.3	- 245.7
108	57.6-64.4	6.52	483.61	178.68	1117.8	134.9	1101.9	- 210.9
109	64.4-70.3	8.46	485.84	184.95	1317.2	124.5	1311.2	- 202.5
110	70.3-75.1	11.59	492.54	188.27	2192.5	184.2	2116.1	- 436.1
120	75.1-TOP	31.30	492.31	196.50	4604.6	448.3	4283.9	- 834.1
TOTAL		115.37	480.72	171.49	96118.3	60499.9	37648.3	21782.0

BALANCE WEIGHTS

PANEL NO.*	PANEL BOUNDARIES STAB. STA.	WEIGHT POUNDS	\bar{X} PANEL C.G. FUS. STA.	\bar{Z} PANEL C.G. WATERLINE
101	0-16.8	1.87	492.0	129.0
102	16.8-23.6	1.88	493.5	133.4
103	23.6-30.4	1.49	495.8	141.0
104	30.4-37.2	1.56	497.9	147.4
105	37.2-44.0	1.66	499.9	153.0
106	44.0-50.8	1.41	501.8	159.2
107	50.8-57.6	.52	503.9	166.0
108	57.6-64.4	.52	506.0	173.0
109	64.4-70.3	.45	508.1	179.0
110	70.3-72.05	.11	509.1	182.0
TOTAL		11.47	497.8	147.3

*See Fig. 14

REPORT NO.
64B148

WEIGHT AND BALANCE REPORT
XV-5A

PAGE 199

4.6 Instrumentation Moment of Inertia

INSTRUMENTATION MOMENTS OF INERTIA

BREAKDOWN BY AREA	WEIGHT POUNDS	\bar{X} FUS. STA.	\bar{Z} WATER-LINE	\bar{Y} BUTTOCK LINE	I_x ROLL LB. IN ²	I_y PITCH LB. IN ²	I_z YAW LB. IN ²
Wing	28.41	250.3	100.9	70.6	25144.4	14697.6	39752.0
Fuselage	478.28	152.3	103.0	0	151122.3	2172986.6	2186931.0
Horiz. Stab.	5.13	483.6	199.4	12.9	3036.6	874.6	3692.0
Vert. Stab.	3.11	478.9	159.9	0	2027.9	2711.8	686.6
Aileron	.07	317.7	102.0	126.0	0	0	0
Total Instru.	515.0	163.0	104.2	0	382287.3	3359135.0	3485530.0