

AD

PULSED MAGNETIC FIELD
FERROMAGNETIC MICROWAVE GENERATOR



AD656473

First Quarterly Progress Report
1 January 1967 to 31 March 1967

by
L. D. Buchmiller--F. A. Olson

August 1967

RECEIVED

AUG 21 1967

CFSTI

ECOM

UNITED STATES ARMY ELECTRONICS COMMAND · FORT MONMOUTH, N.J.
DAAB07-67-C-0215

MICROWAVE ELECTRONICS, a Division of Teledyne, Inc.
Palo Alto, California 94304

Distribution of this Document is Unlimited

29

PULSED MAGNETIC FIELD
FERROMAGNETIC MICROWAVE GENERATOR

Report No. 1
Contract No. DAAB07-67-C-0215

First Quarterly Progress Report
1 January 1967 to 31 March 1967

Object

To develop a microwave nanosecond pulse generator
using ferrimagnetic materials subjected to pulsed
magnetic fields.

prepared by
L. D. Buchmiller

approved by
F. A. Olson

Distribution of this Document is Unlimited

PULSED MAGNETIC FIELD
FERROMAGNETIC MICROWAVE GENERATOR

Report No. 1
Contract No. DAAB07-67-C-0215

First Quarterly Progress Report
1 January 1967 to 31 March 1967

Object

To develop a microwave nanosecond pulse generator
using ferrimagnetic materials subjected to pulsed
magnetic fields.

prepared by
L. D. Buchmiller

approved by
F. A. Olson

Distribution of this Document is Unlimited

CONTENTS

	<u>Page</u>
PURPOSE	iii
ABSTRACT	iv
PUBLICATIONS, LECTURES, REPORTS AND CONFERENCES	v
FACTUAL DATA	
PART I: INTRODUCTION	:
PART II: EXPERIMENTAL WORK	2
A. Stanford Model II-B Generator	2
B. Triggered Spark Gap	7
C. Modification of Pulsing Process	7
PART III: PULSER INVESTIGATIONS	14
CONCLUSIONS	15
FUTURE WORK	16
REFERENCES	17
IDENTIFICATION OF KEY TECHNICAL PERSONNEL	18

ILLUSTRATIONS

<u>Figure</u>		<u>Page</u>
1.	Principal measuring setup used in the experimental testing of the X-band ferrite pulse generator.	3
2.	(a) Pulse shape with sharpening gap adjusted for maximum RF power output; (b) pulse shape with sharpening gap shorted. Vertical scale is 2,360 V/div. (based on 11,800 voltage divider) and the horizontal scale is 0.5 ns/div.	4
3.	Outline drawing of ITT F-2720-11 spark gap switch.	6
4.	Mounting schematic for ITT switch on 7.6-ohm stripline.	8
5.	(a) Pulse shape of ITT switch in 7.6-ohm stripline. (b) Stanford pulser. The charging line voltage is 10 kV for both cases. The vertical scales are 1180 V/div. (based on 11,800 divider) and the horizontal scales are 1 ns/div.	9
6.	Measured value of pulsed magnetic field versus time.	10
7.	Illustration of proposed process for increasing the final precession angle.	12

PURPOSE

The purpose is to determine the feasibility of a microwave generator in which a ferrite material is used to convert energy from a pulsed magnetic field into coherent energy.

The investigation includes studies of generator performance features and limitations, and the fabrication of an exploratory developmental model to demonstrate microwave generation of X-band power at nanosecond pulse widths by the use of a ferromagnetic material emersed in a pulsed magnetic field. The design objectives are as follows:

RF Pulse Width	1 to 3 nanoseconds
Center Frequency	9.6 GHz
Frequency Tuning Range	9.6 GHz \pm 4 percent
Peak Power	2 kW
Pulse Repetition Rate	1 to 10 KHz

The unit is to be self-contained, including pulsing circuitry with only applied dc voltages required. Maximum overall efficiency, reliability, life and simplicity of operation are desired characteristics.

ABSTRACT

Operating experience has been obtained with the Stanford Model II-B pulsed ferrite X-band generator. Preliminary pulser tests were performed with a commercially available voltage-triggered spark gap switch. A pulse rise time of one nanosecond at 10 kV was obtained at a pulse repetition frequency of 1000 Hz.

PUBLICATIONS, LECTURES, REPORTS AND CONFERENCES

There were, during the first quarter, no publications, lectures or reports resulting from research carried on under this contract. A conference was held on 4 January 1967 between MEC personnel, Dr. H. J. Shaw of Stanford University (consultant), and Mr. John Carter to determine the direction of future efforts. It was determined that the principal design objectives are to increase power output and provide pulse triggering with minimum jitter.

FACTUAL DATA

PART I: INTRODUCTION

The objective of this program is an engineering and packaging improvement of a developmental model X-band generator, based on the results achieved at Stanford University under Contract DA 28-043-AMC-00397 (E).

The basic theory, final experimental model, and experimental results are described in a recent publication by Stanford personnel¹ and will not be repeated here.

The latest experimental generator model was borrowed from Stanford, and work during this first quarter consisted primarily in gaining operating experience with this equipment and reviewing previous reports and publications. Some initial pulser work using a commercial triggered spark gap was performed and preparations are underway for measurements of a modified process proposed by Stanford personnel².

PART II: EXPERIMENTAL WORK

A. Stanford Model II-B Generator

The Stanford Model II-B Generator has been borrowed from Stanford in order to gain operating experience and perform initial experiments. The principal measuring setup used is shown in Fig. 1. The 7 to 11 GHz sweep generator in conjunction with the Tek 545 scope is used to measure the resonance of the ferrite-to-waveguide coupling slot in the pulsed field coil and provides an indication of the output frequency of the generator. The pulse energy is determined by measuring average power with the -hp-431B power bridge and dividing by the pulse repetition frequency; the PRF is determined in turn by the -hp-130B scope which is connected to a pickup loop placed near the main spark gap. The pulser voltage is measured at a point midway along the isolation stripline which connects the pulse sharpening gap to the pulse-coil load. The pulse voltage is divided by a factor of 11,800 by the Stanford pulse voltage divider and observed on a Tektronix 661 sampling scope. The waveguide switch connected to directional coupler No. 2 is used to protect the thermistor while the sweep generator is on for measuring slot resonance (output frequency). The main spark gap is operated at 100 pounds pressure with pure nitrogen gas. The sharpening gap is operated at atmospheric pressure.

The maximum average power output measured from this generator is 65 microwatts at a PRF of 200 Hz. The peak energy, as determined by dividing average power by PRF, is 326 watt-nanoseconds and is the same as measured by Stanford with a similar 48-mil YIG sphere.

The pulse shape observed on the Tek 661 sampling scope for this maximum output power is shown in Fig. 2(a). This shape results by adjusting the sharpening gap for maximum power output. The pulse shape obtained with the sharpening gap shorted out is shown in Fig. 2(b). Note the increase in the rise

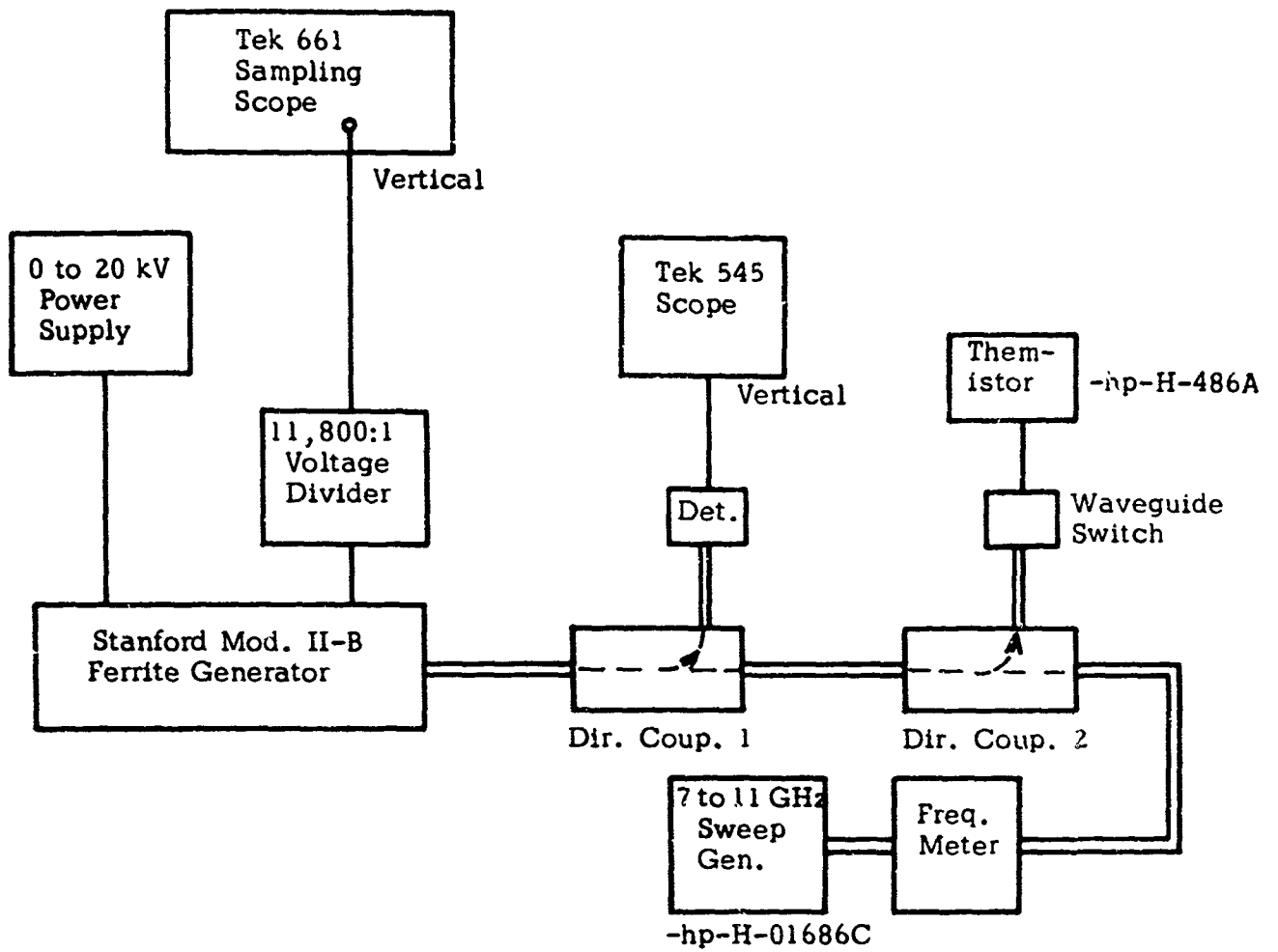

Fig. 1. Principal measuring setup used in the experimental testing of the X-band ferrite pulse generator.

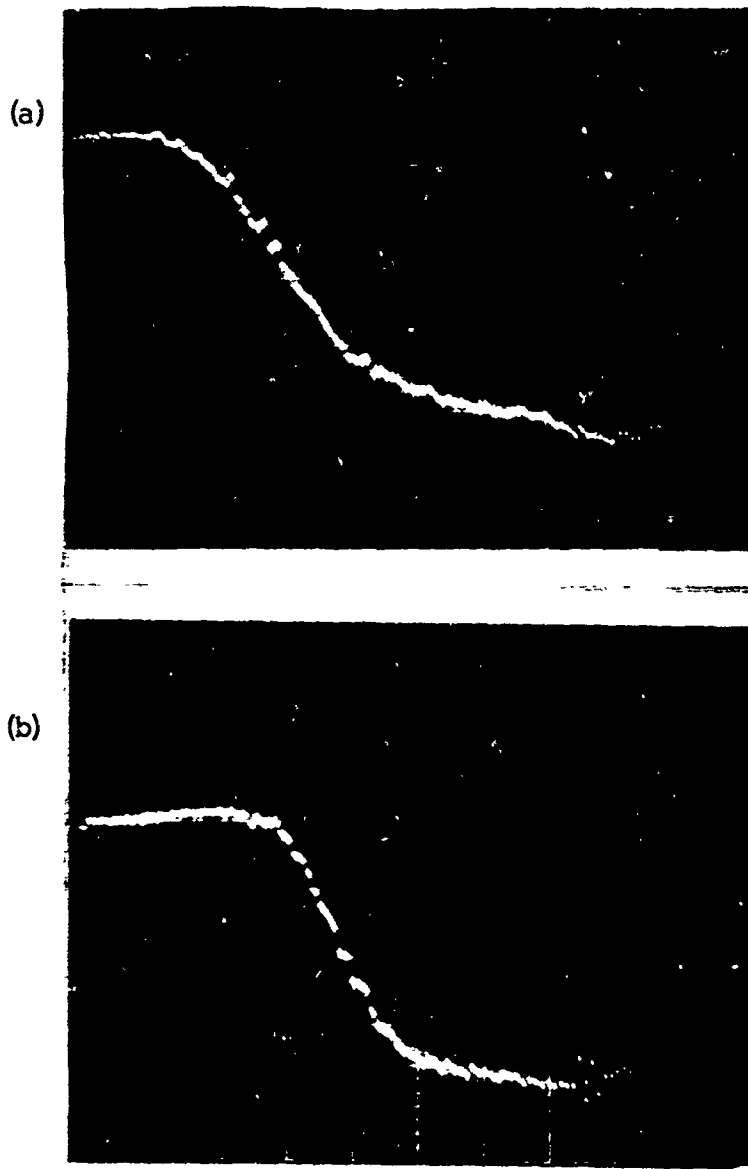

Fig. 2. (a) Pulse shape with sharpening gap adjusted for maximum RF power output; (b) pulse shape with sharpening gap shorted. Vertical scale is 2,360 V/div. (based on 11,800 voltage divider) and the horizontal scale is 0.5 ns/div.

time of the pulse. The slope of the linear portion of the pulse in Fig. 2(a) is 9.4 kV/ns while that in Fig. 2(b) is 6.6 kV/ns. This change in pulse shape decreases the average power from 65 to 10 microwatts, a factor of 6.5. This indicates that RF power output is a good measure of the relative merits of various pulsing systems.

B. Triggered Spark Gap

Pulser experiments were performed with a recently available, commercial, triggered spark gap switch (Model F-2720-11, ITT Electron Tube Division, Easton, Pa.). This switch has the following characteristics:

1. Operating range is 3.5 to 11 kV
2. Static breakdown potential is 14 kV
3. Trigger potential is 10 kV
4. Energy discharge is 300 joules
5. Peak current is 20 kA
6. Delay time is 60 ns
7. Metal-ceramic construction
8. Pressurized inert gas to increase switching speed
9. Small size. (See Fig. 3 for dimensions.)

Life time data is not yet supplied by the manufacturer but one switch has been used by a customer discharging a 0.1- μ F condenser at 500 PRF for approximately 2000 hours. It should be noted that the 20-kA, 300-joule capabilities far exceed the generator requirements so that life is not expected to be a problem.

This switch has been operated with a laboratory 1000-volt pulser and a pulse transformer with a trigger voltage of approximately 4 kV with PRF to 1000 Hz. The switch was tested by mounting on low inductance contact blocks

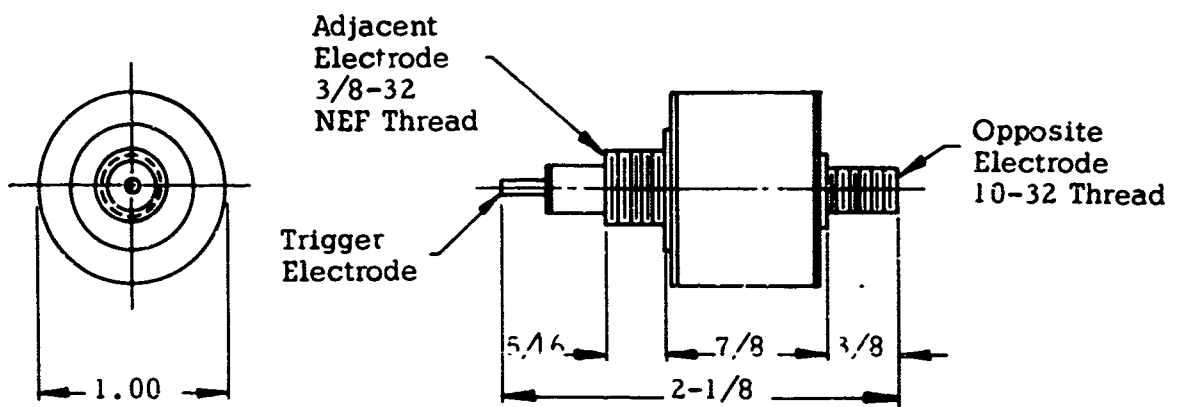

Fig. 3. Outline drawing of ITT F-2720-11 spark gap switch.

and replacing the pressurized primary gap of the Stanford pulser as shown in Fig. 4. The pulse shape as measured on the output stripline after passing through the sharpening gap is shown in Fig. 5(a). The dc charging voltage was 10 kV. The pulse rise time is approximately one nanosecond and compares closely to the pulse obtained from the Stanford pulser shown in Fig. 5(b).

Some improvement in the pulse rise time of the ITT switch may be obtained by applying the rated trigger voltage of 10 kV or higher. Trigger circuitry using an SCR switch is now being constructed.

It should be noted that the breakdown voltage of the ITT switch is too low to perform RF tests with the 7.6-ohm stripline currently being used in the Stanford generator. Tests will be performed to determine the lowest value of characteristic impedance (Z_0) usable with coaxial line construction. The minimum value of Z_0 is established by the time constant of the pulsed coil inductance, the switch inductance, and the characteristic impedance of the line; i.e., $\tau = L/Z_0$. The inductance of the pulsed-field coil is one nanohenry so the coil time constant with the 7.6-ohm line is 0.13 ns. Lowering Z_0 will increase the time constant; however, the use of coaxial construction will tend to reduce the inductive discontinuities due to the spark gap switch³.

C. Modification of Pulsing Process

The measured pulsed field, H_p , is shown as a function of time in Fig. 6. The pulse shape can be conveniently described in terms of a parabolic region and a linear region. It has been shown (Ref. 2, Sec. III) that the initial parabolic portion has a harmful effect on the magnitude of the precession angle obtainable. The parabolic effect reduces the precession angle by a factor of 2.5, which leads to a reduction in energy of 7.8 db. It is to be expected that the output energy of the generator could be increased by this amount if the parabolic effect could be eliminated.

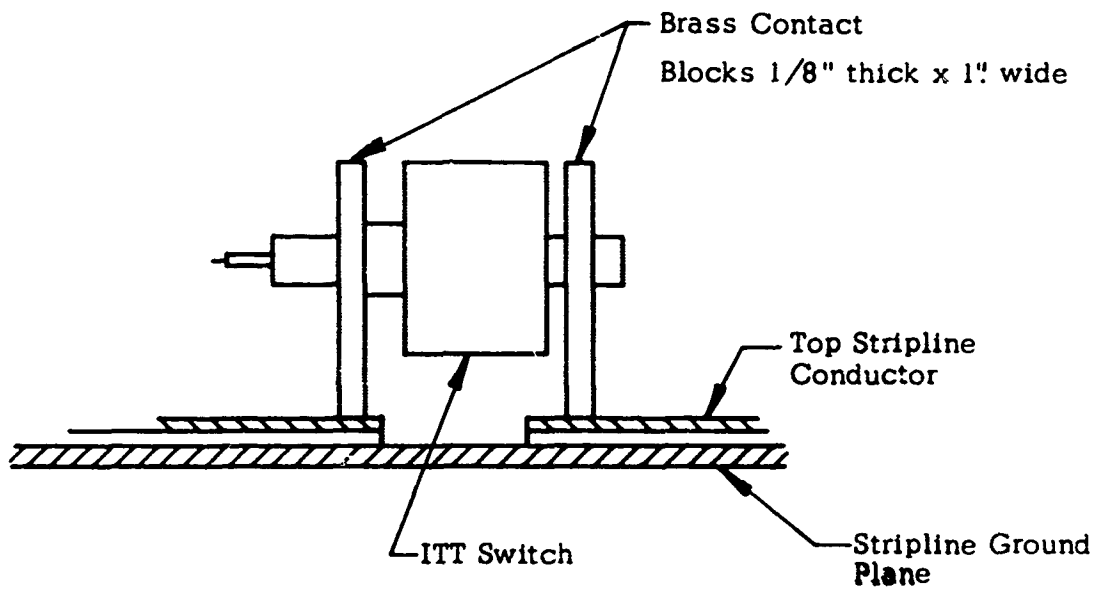

Fig. 4. Mounting schematic for ITT switch on 7.6-ohm stripline.

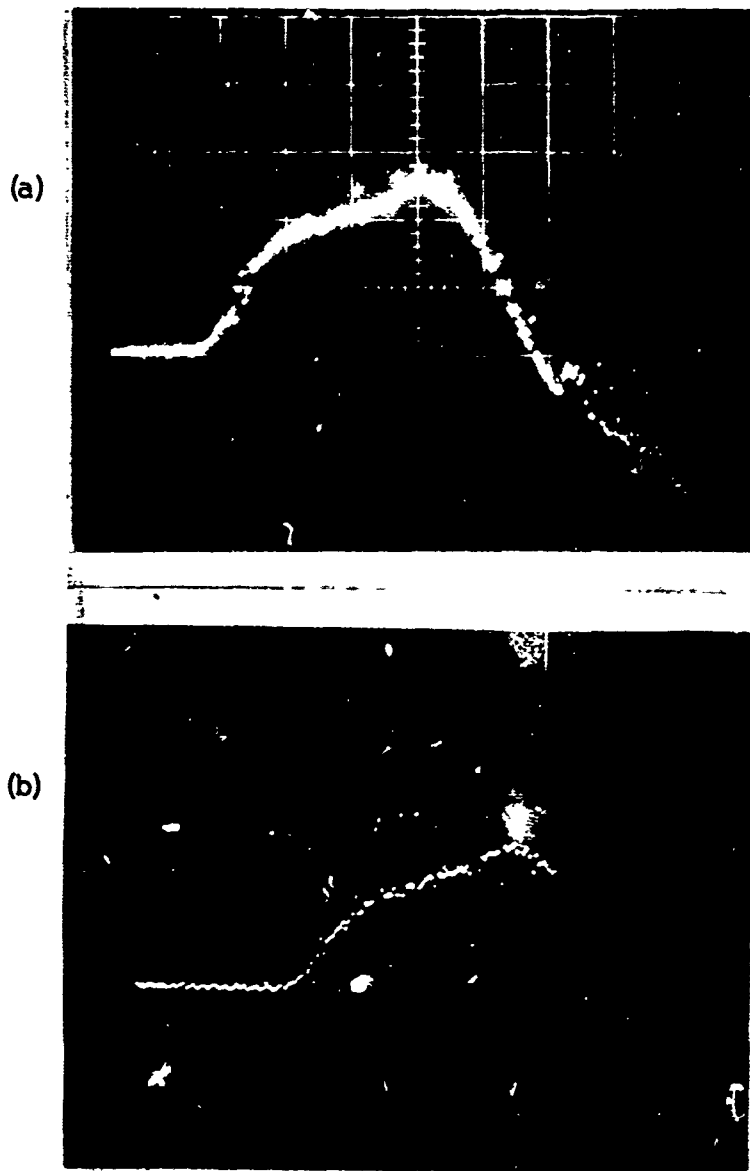

Fig. 5. (a) Pulse shape of ITT switch in 7.6-ohm stripline.
(b) Stanford pulser. The charging line voltage is 10 kV for both cases. The vertical scales are 1180 V/div. (based on 11,800 divider) and the horizontal scales are 1 ns/div.

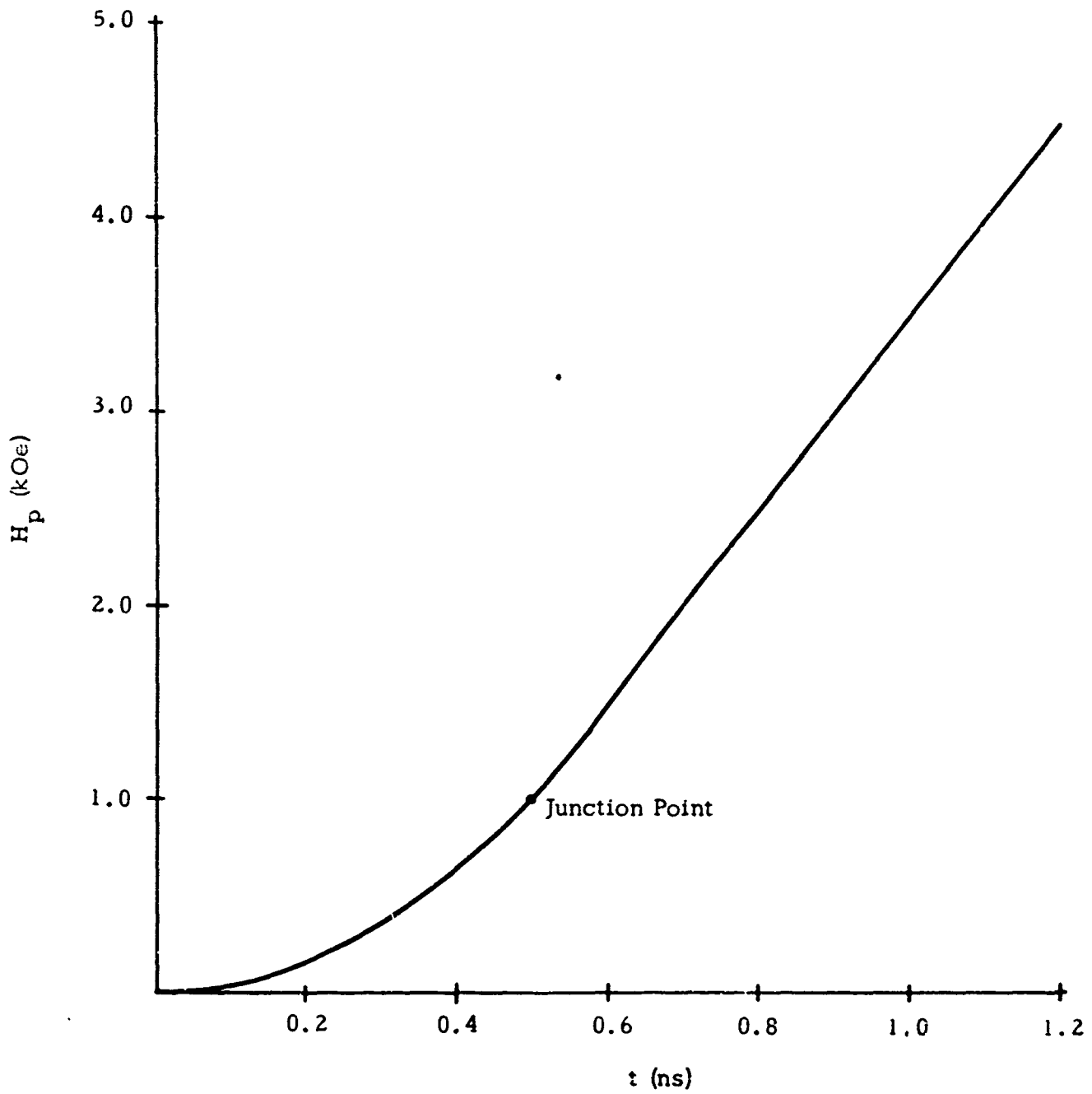

Fig. 6. Measured value of pulsed magnetic field versus time.

A new approach², aimed at overcoming the limitation of precession angle due to the parabolic effect in the pulsed field, is illustrated by Fig. 7. Here the pulsed magnetic field H_p is applied at an angle to H_0 which exceeds 90 degrees; i.e., the pulsing angle ψ_0 exceeds 90 degrees. The vectors 1, 2 and 3 represent the total magnetic field at three successive instants of time during the pulsed field buildup. It is seen that the total field magnitude at first decreases monotonically with time until it reaches the value of vector 2, and thereafter increases monotonically with time. The portion labeled parabolic range in Fig. 7 covers the time interval required to reach the junction point on the H_p curve of Fig. 6. During this interval the precession frequency is relatively high and the sweep rate is low, so that very little precession angle is established. The interval between vectors 1 and 3, labeled excitation range, is the interval during which the precession frequency is lowest and the angular velocity of the total field vector is highest. This is the nonadiabatic region during which excitation of a large precession angle is expected to occur. The pumping range beyond vector 3 is the range during which the magnitude of the precession angle remains substantially constant while its frequency and energy are pumped upward by the pulsed field, just as in the present generator.

The principal idea involved in this approach is that the parabolic region of the pulsed field rise, which involves a very low average rate of rise, is moved outside the critical region of low precession frequency. The low frequency region is then traversed with high angular velocity, a condition necessary for the establishment of large precession angle. The entire precession angle is almost completely established during the first one to two radians of precession in the region of lowest precession frequency.

This mode of operation has a further possible advantage which may be of importance. Theory and experiment both predict a rapid increase of energy

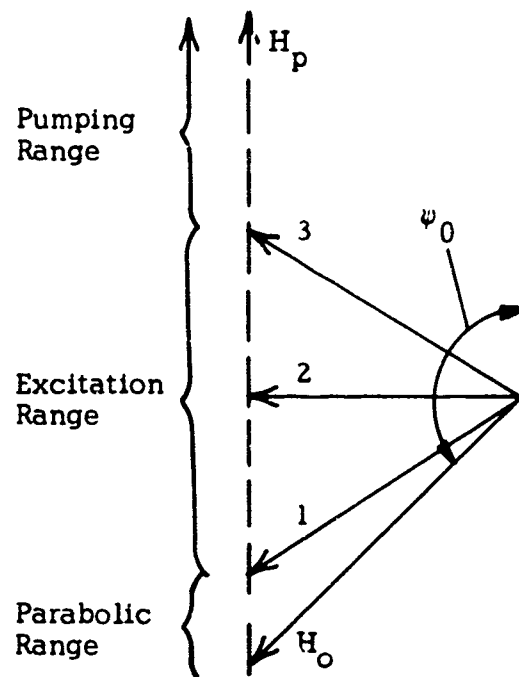

Fig. 7. Illustration of proposed process for increasing the final precession angle.

with decrease in magnitude of the dc bias field, and the present approach, by pulsing rapidly through the region of minimum total field instead of dwelling in that region for a long period of time as in the present operation, may allow the use of small minimum field before the formation of domains in the ferrite becomes harmful. That is, as the total field vector sweeps through position 2 in Fig. 7, it may be possible for its magnitude to dip below the allowable field minimum required to maintain saturation in the case of a dc field. Due to the rapid sweep rate through this region, and to the reasonably small average angle between the total field and the magnetization in this region, this fact may be of importance in producing a second increase in the final precession angle and energy—over and above the increase due to elimination of the parabolic effect.

Preparations are under way for performing measurements with the modified pulsing process.

PART III: PULSER INVESTIGATIONS

A literature survey of short rise time, high current, high voltage pulsers indicate that there have been some recent innovations but that these pulsers currently have low pulse repetition rates⁴. A recent publication⁵ by McDonald et al describes a subnanosecond rise time pulse generator which is similar in operation to the Stanford pulser now being used and described by Elliott⁶. Both types use a primary gap or "slow" switch and a sharpening gap or "fast" switch. The principal difference is that in McDonald's pulser the primary gap operates in air and the sharpening gap works under controlled vacuum conditions whereas the Stanford pulser uses nitrogen gas at 100 pounds pressure for the primary gap, and the sharpening gap operates in air. A further difference is that the McDonald pulser is of coaxial line construction for operation at higher voltages. The system generates 60 kV pulses with rise time of 0.3 ns.

Both the above pulsing systems are free running, but triggering with intense ultraviolet light is feasible³. The advantages of ultraviolet triggering are:

1. nanosecond breakdown time,
2. time jitter as low as 1 ns,
3. complete electrical isolation between the trigger circuit and the main gap circuit.

Further consideration will be given to ultraviolet light and other triggering techniques for this generator model.

CONCLUSIONS

Operating experience has been obtained with the ferrite X-band generator developed by Stanford University under Contract DA-28-043-AMC-00397 (E).

Preliminary tests were performed on a triggered pulser using a commercially available (ITT) spark gap switch. The 1-ns rise time of this switch at 10 kV is comparable to that of the Stanford generator. A pulse repetition frequency of 1000 Hz was obtained.

FUTURE WORK

Work on increasing power output will be done by:

1. performing measurements with the modified pulsing technique,
2. optimizing ferrite-circuit coupling for single ferrite sphere operation, and
3. establishing goals for and initiating SRI's investigation of multiple-sphere operation.

Work on triggered pulser operation will continue with voltage-triggered commercial spark gap switches and ultraviolet triggering of the Stanford spark gap switch.

REFERENCES

1. H.J. Shaw, B.J. Elliott, K.J. Harker, and A. Karp, "Microwave Generation in Pulsed Ferrites", J.A.P. 37, No. 3, pp. 1060-1066, 1 March 1966.
2. H.J. Shaw, "Pulsed Ferrite X-band Generator", Final Report for Contract DA-28-043-AMC-00397 (E), U.S. Army Electronics Command, Fort Monmouth, New Jersey, Sept. 1966, or M.L. Report No. 1467, Stanford University, Stanford, California.
3. T.F. Godlove, "Nanosecond Triggering of Air Gaps with Intense Ultraviolet Light", J.A.P. 32, No. 8, pp. 1589-1596, August 1961.
4. A.T. Cummings and H.R. Wilson "High Voltage Nanosecond Switch", Proc. IEEE (Corr.), vol. 53, p. 757, July 1965.
5. D.F. McDonald and C.F. Benning, "Subnanosecond Rise Time Multi-kilovolt Pulse Generator", Rev. of Scien. Inst. 36, No. 4, p. 504-506, April 1965. See also D.F. McDonald, "High-Voltage" Nanosecond Switch, IEEE, (Corr.) p. 1739, November 1965.
6. B.J. Elliot, "On the Generation of Intense Fast-Rising Magnetic Field Pulses", M.L. Report No. 1095, Microwave Laboratory, Stanford University, Stanford, California.

IDENTIFICATION OF KEY TECHNICAL PERSONNEL

Key technical personnel and respective man-hours devoted to the contract during this reporting period are listed below.

L. D. Buchmiller, Senior Research Engineer	154 hours
W. Mitchell, Research Technician	182 hours

Security Classification

DOCUMENT CONTROL DATA - R&D

(Security classification of title, body of abstract and indexing annotation must be entered when the overall report is classified)

1 ORIGINATING ACTIVITY (Corporate author) MICROWAVE ELECTRONICS A Division of Teledyne, Inc. 3165 Porter Drive Palo Alto, California 94304		2a REPORT SECURITY CLASSIFICATION Unclassified	
		2b GROUP N/A	
3 REPORT TITLE PULSED MAGNETIC FIELD FERROMAGNETIC MICROWAVE GENERATOR			
4 DESCRIPTIVE NOTES (Type of report and inclusive dates) First Quarterly Report - 1 January 1967 to 31 March 1967			
5 AUTHOR(S) (Last name, first name, initial) Buchmiller, L. D. Olson, F. A.			
6 REPORT DATE August 1967		7a. TOTAL NO. OF PAGES 24	7b. NO. OF REFS 6
8a. CONTRACT OR GRANT NO. DAAB07-67-C-0215		8c. ORIGINATOR'S REPORT NUMBER(S)	
b. PROJECT NO.		8b. OTHER REPORT NO(S) (Any other numbers that may be assigned this report) ECOM-0215-1	
c.			
d.			
10. AVAILABILITY/LIMITATION NOTICES Distribution of this Document is Unlimited			
11. SUPPLEMENTARY NOTES		12. SPONSORING MILITARY ACTIVITY U.S. Army Electronics Command Fort Monmouth, New Jersey 07703 Attn: AMSEL-KL-TG	
13 ABSTRACT Operating experience has been obtained with the Stanford Model II-B pulsed ferrite X-band generator. Preliminary pulser tests were performed with a commercially available voltage-triggered spark gap switch. A pulse rise time of one nanosecond at 10 kV was obtained at a pulse repetition frequency of 1000 Hz.			

Security Classification

14.	KEY WORDS	LINK A		LINK B		LINK C	
		ROLE	WT	ROLE	WT	ROLE	WT
		Ferrite Microwave Generator Nanosecond Pulses					

INSTRUCTIONS

1. **ORIGINATING ACTIVITY:** Enter the name and address of the contractor, subcontractor, grantee, Department of Defense activity or other organization (*corporate author*) issuing the report.
- 2a. **REPORT SECURITY CLASSIFICATION:** Enter the overall security classification of the report. Indicate whether "Restricted Data" is included. Marking is to be in accordance with appropriate security regulations.
- 2b. **GROUP:** Automatic downgrading is specified in DoD Directive 5200.10 and Armed Forces Industrial Manual. Enter the group number. Also, when applicable, show that optional markings have been used for Group 3 and Group 4 as authorized.
3. **REPORT TITLE:** Enter the complete report title in all capital letters. Titles in all cases should be unclassified. If a meaningful title cannot be selected without classification, show title classification in all capitals in parenthesis immediately following the title.
4. **DESCRIPTIVE NOTES:** If appropriate, enter the type of report, e.g., interim, progress, summary, annual, or final. Give the inclusive dates when a specific reporting period is covered.
5. **AUTHOR(S):** Enter the name(s) of author(s) as shown on or in the report. Enter last name, first name, middle initial. If military, show rank and branch of service. The name of the principal author is an absolute minimum requirement.
6. **REPORT DATE:** Enter the date of the report as day, month, year, or month, year. If more than one date appears on the report, use date of publication.
- 7a. **TOTAL NUMBER OF PAGES:** The total page count should follow normal pagination procedures, i.e., enter the number of pages containing information.
- 7b. **NUMBER OF REFERENCES:** Enter the total number of references cited in the report.
- 8a. **CONTRACT OR GRANT NUMBER:** If appropriate, enter the applicable number of the contract or grant under which the report was written.
- 8b, 8c, & 8d. **PROJECT NUMBER:** Enter the appropriate military department identification, such as project number, subproject number, system numbers, task number, etc.
- 9a. **ORIGINATOR'S REPORT NUMBER(S):** Enter the official report number by which the document will be identified and controlled by the originating activity. This number must be unique to this report.
- 9b. **OTHER REPORT NUMBER(S):** If the report has been assigned any other report numbers (*either by the originator or by the sponsor*), also enter this number(s).
10. **AVAILABILITY/LIMITATION NOTICES:** Enter any limitations on further dissemination of the report, other than those

imposed by security classification, using standard statements such as:

- (1) "Qualified requesters may obtain copies of this report from DDC."
- (2) "Foreign announcement and dissemination of this report by DDC is not authorized."
- (3) "U. S. Government agencies may obtain copies of this report directly from DDC. Other qualified DDC users shall request through _____."
- (4) "U. S. military agencies may obtain copies of this report directly from DDC. Other qualified users shall request through _____."
- (5) "All distribution of this report is controlled. Qualified DDC users shall request through _____."

If the report has been furnished to the Office of Technical Services, Department of Commerce, for sale to the public, indicate this fact and enter the price, if known.

11. **SUPPLEMENTARY NOTES:** Use for additional explanatory notes.

12. **SPONSORING MILITARY ACTIVITY:** Enter the name of the departmental project office or laboratory sponsoring (paying for) the research and development. Include address.

13. **ABSTRACT:** Enter an abstract giving a brief and factual summary of the document indicative of the report, even though it may also appear elsewhere in the body of the technical report. If additional space is required, a continuation sheet shall be attached.

It is highly desirable that the abstract of classified reports be unclassified. Each paragraph of the abstract shall end with an indication of the military security classification of the information in the paragraph, represented as (TS), (S), (U), or (U).

There is no limitation on the length of the abstract. However, the suggested length is from 150 to 225 words.

14. **KEY WORDS:** Key words are technically meaningful terms or short phrases that characterize a report and may be used as index entries for cataloging the report. Key words should be selected so that no security classification is required. Identifiers, such as equipment model designation, trade name, military project code name, geographic location, may be used as key words but will be followed by an indication of technical context. The assignment of links, rules, and weights is optional.