

FOREIGN TECHNOLOGY DIVISION

AD 655365

7167-62360



TECHNICAL CYBERNETICS

By

L. P. Krayzmer



D D C
RECEIVED
JUL 31 1967
REGULATED
B

RECEIVED

AUG 3 1967

CFSTI

Distribution of this document is unlimited. It may be released to the clearinghouse, Department of Commerce, for sale to the general public.



**Best
Available
Copy**

FTD-MT-65-422

EDITED MACHINE TRANSLATION

TECHNICAL CYBERNETICS

By: L. P. Krayzmer

English Pages: 95

TM7500011

THIS TRANSLATION IS A RENDITION OF THE ORIGINAL FOREIGN TEXT WITHOUT ANY ANALYTICAL OR EDITORIAL COMMENT. STATEMENTS OR THEORIES ADVOCATED OR IMPLIED ARE THOSE OF THE SOURCE AND DO NOT NECESSARILY REFLECT THE POSITION OR OPINION OF THE FOREIGN TECHNOLOGY DIVISION.

PREPARED BY:

**TRANSLATION DIVISION
FOREIGN TECHNOLOGY DIVISION
WP-AFB, OHIO.**

FTD-MT-65-422

AFLC-WPAFB-JUL 67 133

Date 24 Apr. 1967

FORM 1			
DATE	DATE RECEIVED		
BY	BY		
CLASSIFIED	<input type="checkbox"/>		
UNCLASSIFIED	<input type="checkbox"/>		
REASON FOR DENIAL/AVAILABILITY CODES			
DATE	AGENCY	HOW/WHY	SPECIAL
2			

This document is a machine translation of Russian text which has been processed by the AN/GSQ-16(XW-2) Machine Translator, owned and operated by the United States Air Force. The machine output has been post-edited to correct for major ambiguities of meaning, words missing from the machine's dictionary, and words out of the context of meaning. The sentence word order has been partially rearranged for readability. The content of this translation does not indicate editorial accuracy, nor does it indicate USAF approval or disapproval of the material translated.

Massovaya Radiobiblioteka

Vypusk 542

L. P. Krayzner

TEKHNICHESKAYA KIBERNETIKA

Izdaniye vtoroye, dopolnennoye
i pererabotannoye

Izdatel'stvo "Energiya"

Moskva - 1964 - Leningrad

Page 1-88

CIRC ABSTRACT WORK SHEET									
(71) Acc No. TN7500011		(65) SIS Acc No.		(70) Country of Info UR			(41) Translation No. 326503422		
(42) Author KREMENTZ, L. P.					(41) Priority A1				
(43) Source TEKHNIKA IBERNETIKI									
(72) Ctry UR	(83) Ref C000	(84) Yr 64	(85) Vol C00	(86) Iss C00	(87) S. Pg C001	(45) E. Pg C005	(73) Date NONE	(47) Subject Code 06, 09	
Language RUSSIAN	(11) Edition 1/A	(12) Place Published MOSCOW		(13) Publisher IZD-VO ENERGIYA					
(39) Topic Tags: information processing, information storage and retrieval, bionics, information theory, automatic control system, electronic simulation									
(66) Foreign Title SEE SOURCE									
(09) English Title TECHNICAL CYBERNETICS									
(67) Additional Information (97) HEADER CLASS 0				(63) Class C3		(64) Rel 0		(60) Requester	

ABSTRACT: The basic ideas of cybernetics are popularly expounded as the science of the general principles of control. Primary attention is allotted to technical cybernetics, in which we consider questions of the control of technical processes, and the creation of artificial controlling systems consisting of devices for perception, transmission, storage, and processing of information. Elementary information from information theory is given as well as that on automatic adjustment and electronic computers. The possibilities of fulfillment by the latter of different logical functions are considered. A considerable quantity of practical applications of cybernetic technology is described both in the field of automation of control, calculation and planning, as well as in the field of simulation of physiological processes in living organisms. In this second edition broader materials are represented regarding information-logical machines, information converters, self-organized systems, and bionic methods of improving cybernetic technology. The book was written for radio hams and for wide circles of persons familiar with radio electronics and interested in the questions of cybernetics. To master the material of this book a general preparation in a secondary school is fully sufficient. English Translation: 94 pages.

TABLE OF CONTENTS

U. S. Board on Geographic Names Transliteration System..... 11

Introduction..... 1

Chapter I. Basic Ideas of Technical Cybernetics..... 5

 1. General Control Principles..... 5

 2. Automatic Devices..... 11

 3. Automatic Adjustment..... 12

 4. Information Theory..... 17

 5. Calculation Systems..... 24

Chapter II. Electronic Computers..... 31

 6. General Information About Computers..... 31

 7. Triggers and Their Application in Cybernetic Technology..... 34

 8. Information Storage Devices..... 40

 9. Arithmetic Units..... 49

 10. Devices of Input and Output..... 52

 11. Information Converters..... 53

 12. Types of Electronic Computers and the Prospects of Their
 Development..... 57

 13. Principles of Work Programming of Machines..... 59

Chapter III. Cybernetic Devices and Their Use..... 63

 14. Controlling Machines..... 63

 15. Informational-Logical Machines..... 72

 16. Self-Organized Systems..... 84

 17. Bionical Ways of Development of Cybernetic Technology..... 90

Literature..... 93

U. S. BOARD ON GEOGRAPHIC NAMES TRANSLITERATION SYSTEM

Block	Italic	Transliteration	Block	Italic	Transliteration
А	<i>А</i>	A, а	Р	<i>Р</i>	R, r
Б	<i>Б</i>	B, b	С	<i>С</i>	S, s
В	<i>В</i>	V, v	Т	<i>Т</i>	T, t
Г	<i>Г</i>	G, g	У	<i>У</i>	U, u
Д	<i>Д</i>	D, d	Ф	<i>Ф</i>	F, f
Е	<i>Е</i>	Ye, ye; E, e*	Х	<i>Х</i>	Kh, kh
Ж	<i>Ж</i>	Zh, zh	Ц	<i>Ц</i>	Ts, ts
З	<i>З</i>	Z, z	Ч	<i>Ч</i>	Ch, ch
И	<i>И</i>	I, i	Ш	<i>Ш</i>	Sh, sh
Я	<i>Я</i>	Y, y	Щ	<i>Щ</i>	Shch, shch
К	<i>К</i>	K, k	Ъ	<i>Ъ</i>	"
Л	<i>Л</i>	L, l	Ы	<i>Ы</i>	Y, y
М	<i>М</i>	M, m	Ь	<i>Ь</i>	'
Н	<i>Н</i>	N, n	Э	<i>Э</i>	E, e
О	<i>О</i>	O, o	Ю	<i>Ю</i>	Yu, yu
П	<i>П</i>	P, p	Я	<i>Я</i>	Ya, ya

* ye initially, after vowels, and after ъ, ы; e elsewhere.
 When written as ѐ in Russian, transliterate as yë or ë.
 The use of diacritical marks is preferred, but such marks
 may be omitted when expediency dictates.

Basic ideas of cybernetics are popularly expounded as a science of general principles of control. Primary attention is allotted to technical cybernetics, in which questions are considered of control of technical processes and creation of artificial controlling systems, consisting of devices for perception, transmission, storage, and processing of information. Elementary information from information theory, is given as well as that of automatic adjustment and electronic computers. Possibilities are considered of fulfillment by the latter of different logical functions. Considerable quantity of practical applications of cybernetic technology is described both in field of automation of control, calculation and planning, as well as in field of simulation of physiological processes in living organisms. In second publication materials are represented more widely regarding informational-logical machines, information converters, self-organized systems, and bionical methods of improving cybernetic technology.

The book was written for radio amateurs and for wide circles of persons, familiar with radio electronics and interested in the questions of cybernetics. For mastering the material of the book general preparation in a secondary school is fully sufficient.

Editorial Board:

A. I. Berg, F. I. Burdeynny, V. A. Burlyand, V. I. Vaneyev, Ye. N. Genishta, I. P. Zhrebtsov, A. M. Kanayeva, V. G. Korol'kov, E. T. Krenkel', A. A. Kulikovskiy, A. D. Smirnov, F. I. Tarasov and V. I. Shamshur.

INTRODUCTION

Our generation is the witness of rapid development of science and technology. The boldest fantasies, until recently seeming to be unrealizable dreams, are embodied in life. In the last three hundred years, humanity has passed from the simplest steam engines to motors working on atomic energy; it has mastered supersonic speeds of flight, attaining several thousand kilometers per hour. People have harnessed the energy of huge rivers, created gigantic excavating mechanisms, replacing the labor of tens of thousands of diggers. The launching of Soviet artificial earth satellites began the attack of outer space of the universe. The greatest achievements of technical thought of man are such accomplishments, as the multi-day flights of Soviet astronauts in satellite vehicles in circumterrestrial orbit, photographing the reverse side of the moon, and creation of maneuvering space satellites. Also created are numerous instruments and devices which increase sharpness of senses of person.

Force of human genius knows no boundaries in the knowledge and subordination of nature to itself, in the creation of newer and newer machines and apparatuses, facilitating and replacing the physical labor of man, colossally increasing the force of his hands, making possible movement with great speeds, and immeasurably increasing the sharpness of his sensory organs.

However, until very recently almost all, even the most accomplished mechanisms and instruments were designed for the execution of highly varied but only executive functions. Their construction always anticipated a more or less complicated control, performed by man, which would estimate external situation and external conditions, watch the movement of this or that process, and correspondingly control machines,

movement of transport, etc. The region of mental activity, psychics, the sphere of logical functions of the human brain seemed until recently an absolutely inaccessible mechanization.

In sketching pictures of life of a future society, the authors of fantastic stories and narratives often presented life in a manner that all man's work would be done by machine, and the role of man would be only in watching the work of these machines, and pressing corresponding buttons on a panel controlling defined operations.

However, contemporary level of development of radio electronics permits the scientists and engineers to place and to solve problems of creating new devices, which would free man from the need of watching industrial process and controlling it, i.e., it would replace the operator and the dispatcher. New class of machines has appeared - control machines - which can execute the most varied and often very complicated control problems of industrial processes, movement of transport, control ships, to pilot aircraft, etc. The creation of control machines permits crossing from automation of separate machines and units to overall automation of conveyers, workshops, and entire plants.

The theory of different control systems, or more exactly, the general mathematical theory of control in the widest sense of the word, formed in the last decade in a new, independent scientific direction, has obtained the name cybernetics. The work of cybernetics comes from the Greek word "cybernetes" which signifies "steering," or "pilot."

At the end of last century and mainly in first half of present century, by efforts of numerous domestic and foreign scientists base was prepared for the creation of strict mathematical theory of general principles of automatic adjustment and control. Worthy contribution to it was introduced by such great Russian and Soviet scientists as I. A. Vyshnegradskiy, A. M. Lyapunov, A. A. Markov, V. S. Kulebakin, A. N. Kolmogorov, A. A. Andronov, V. A. Kotel'nikov and others. An important role in the creation of general control theory in living organisms was played by the teaching of reflexes, well-developed by the Russian physiologists I. M. Sechenov and I. P. Pavlov and their followers.

In its contemporary form, cybernetics as a new scientific direction was shaped by great American scientist-mathematician, professor of Massachusetts Institute of Technology, Norbert Wiener (1894-1964), known by his works in field of analysis,

profitability theory and random processes.

As result of deep study of analogies between control processes in technical and biological systems and synthetic mutual enrichment of corresponding divisions of mathematics, radio electronics, and physiology was the general theory of control, developed by Wiener, which he called cybernetics.

During the last decade, the idea of cybernetics has enjoyed the propagation in our country. Without exaggeration it is possible to say that in the USSR, cybernetics has found its own second native land.

In field of cybernetics there work such great Soviet scientists as academicians A. I. Berg, V. N. Glushkov, S. A. Letadev, S. L. Sobolev, V. A. Trapeznikov and A. I. Kohnogorov; corresponding members of Academy of Sciences of USSR A. A. Kharkovich, P. S. Sosakov, L. V. Kantorovich and many others.

The wide front of works in field of cybernetics in our country is the guarantee of new and rapid successes in the development of this, the most interesting region of science, to which the future belongs. In program of CPSU it is said that within a twenty-year period cybernetics, electronic calculating and control systems will enjoy wide use in processes of industry, building industry and transport, in scientific investigations, in planning and project design estimates, and in the sphere of calculation and control.

CHAPTER I

BASIC IDEAS OF TECHNICAL CYBERNETICS

1. General Control Principles

As was said in the introduction, characteristic trait of cybernetics is the joint study of control processes in technical devices and in living organisms. What gives us the right to compare control processes in systems differing so qualitatively from each other?

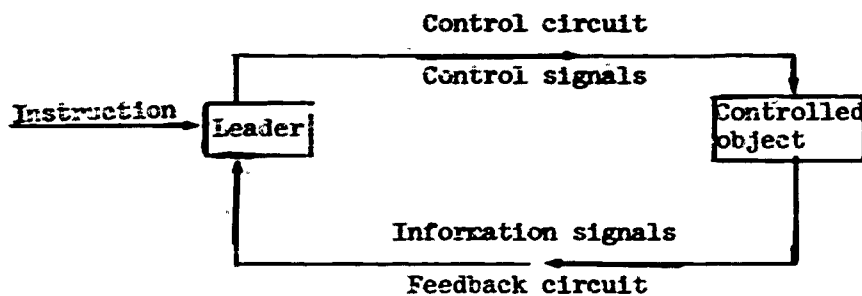

Fig. 1. Block diagram of nonautomatic object control.

In order to establish presence of analogies allowing us to do this, let us consider several general block diagrams of control, pertaining to different systems. The Fig. 1 diagram is represented of nonautomatic control of some form of object (machine, conveyer, workshop, plant, transport unit and so forth), done by man (operator, machinist, dispatcher chief), subsequently named the leader.

Influence of the leader on controlled object can take place by mechanical means, with the help of levers or flexible connecting rods of hydraulic or pneumatic drive; electrical means; a change of currents and voltages brought in or a change of frequency of alternating currents, the series of electrical pulses, and so forth; with the help of oral orders, by telephone or by any other communication channel, if

the controlled object, such as, for instance, a workshop, conveyer, or plant, has executors which control the units in accordance with wishes of the leader. All enumerated and many other means of transmission of the control signals form a control circuit of the object or direct circuit of influence on the controlled object. However, it is absolutely natural that expedient control of the object is impossible, if the leader does not know the state of the object, cannot personally, with the help of instruments or through executors periodically or continuously control the actual state of the object and fulfill the orders of control. Leader must obtain (by so-called channel of feedback) information about the actual behavior of controlled object, compare it with required operating conditions, make corresponding signals or instructions, so-called control information.

Let us consider concrete examples of nonautomatic control.

Let us assume that before the operator (leader) problem is set to support as constant a number of turns of an electric motor, rotating a certain device (object). Let us assume that the assigned speed of electric motor is equal to 1,500 rpm. According to log book data, such rotation speed is obtained at defined values of feed voltage and current in excitation winding.

However, by virtue of a number of circumstances considered with difficulty, such as, for instance, change of load, friction in the bearings, change of ambient temperature, and (connected with this) change of resistance of windings, and others, the actual rotation speed may not correspond to the assigned. This speed must be measured by any method, for instance, by a tachometer, and measurement data must become known to the operator. Data about speeds, measured by the instruments, are transmitted to operator along feedback channel. Knowing, thus, the actual rotation speed of the electric motor, composing, let us say, 1,480 rpm, the operator, following instructions and practical experience, makes a decision to change corresponding (with the help of rheostat) magnitude of excitation current. If, as a result of this, speed of electric motor exceeds the assigned, then by a change of excitation current in opposite direction, it is possible to decrease this speed.

As another, more complicated example let us consider control of a plant (object), performed by dispatcher (leader). By channels of control, connecting the dispatcher with workshops, he issues order to executors subordinated to it, obtaining from them in turn by feedback channels, information about situations in workshops, supply of raw material, issue of ready production, and so forth. On the basis of information

obtained, dispatcher makes certain decisions and issues orders (control signals). In the case of such indirect control over industrial process — through formen of a workshop, executors at the machines and units and other intermediaries, on the one hand, possibility of distortion of control signals is increased by these intermediaries, and on the other hand, movement of the industrial process can be improved due to the fact that the intermediaries do not execute the wishes of the dispatcher mechanically, but can process them creatively, introducing some correctives in the general instructions of the leader.

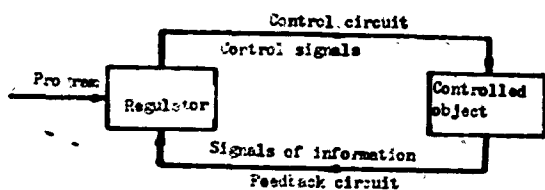

Fig. 2. Block diagram of automatic control.

In Fig. 2 diagram is represented of automatic object control. Diagram as we can see, does not differ externally from the preceding; however, control process is carried out in this case without participation of man. From controlled object, by means of (not shown on diagram) measuring instruments

and converters, information about state of the controlled object along the feedback circuit enters the regulator. Here it is processed, and the regulator (in accordance with obtained data and assigned program) produces control signals, proceeding along control circuits to the object. Program of adjustment can be determined by the actual construction of the regulator or, in more complicated systems, can be introduced into the regulator from without.

As an example of automatic adjustment we will consider well-known design of centrifugal steam engine regulator, invented by Watt in 1784 (Fig. 3). System works

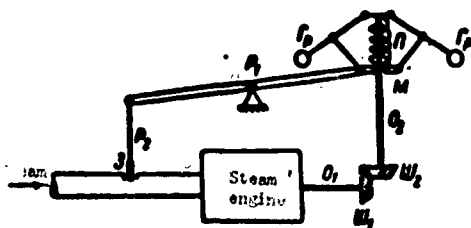

Fig. 3. Diagram of centrifugal regulator of a steam engine.

in the following way. With the axis of machine O_1 , using gears III_1 and III_2 axis of regulator O_2 is connected, coupling M of which, thanks to elasticity of spinning Π , working on compression with motionless machine is in the lowest position. With an increase of rotation speed of the machine, loads Γ_p , under action of centrifugal force, depart from axis

O_2 , compressing spring Π and lifting coupling M . Here levers P_1 and P_2 shift, and flap 3 decreases arrival of steam in cylinders of the machine, which lowers its rpm. Considered system completely corresponds to general diagram of automatic

control (Fig. 2), where the controlled object here is a steam engine; feedback circuit, delivering information to regulator about rotation speed of steam engine, consists of system of axes O_1 and O_2 , gears III_1 and III_2 , and control circuit is formed by levers P_1 and P_2 .

Thus, communication channels in the considered system have a purely mechanical structure.

Program of adjustment (assigned rotation speed of machine and limits of its deviation) depends on construction of the regulator itself, mass of loads G_p and elasticity of spring Π , as well as on characteristic of control and feedback circuits, i.e., relationship of lever arms, transmission ratios of geared engagement, etc. Regulator in this system, replacing man, executes simplest logical function, which can be expressed in the following form: "if speed of machine is great, then it is necessary to decrease admission of vapor; if speed is low, then admission of vapor must be to increased."

In more complicated contemporary systems of automatic adjustment, when the controlled object includes several units or regulation occurs not by one parameter, but by several (for instance, speed, temperature, pressure, and so forth), as communication channels (as a rule) electrical circuits are used, but as the most accomplished regulators, able to perform sufficiently complicated and varied logical functions, electronic computers are used (see Chapters 2 and 3).

Let us now consider control system, acting in living organism. According to the teachings of great Russian physiologist I. P. Pavlov, "the living organism as a system exists among surrounding nature only due to continuous balancing of this system with the external medium, i.e., due to defined reactions of the living system to irritations arriving at it from without, which in the higher animals is carried out chiefly by means of the nervous system in the form of reflexes."¹ The route by which reflex is carried out has obtained in physiology the name reflex arc. Block diagram of reflex arc shown in Fig. 4. Arc consists of not less than two nervous tracts: sensitive and motor, connecting the central nervous system (spinal and brain), executing the function of a regulator, with organs of the living organism which are controlled objects. Reflex arc starts with receptors located in controlled organ; these perceive irritation of the ends of sensitive nerves. If one were to use

¹I. P. Pavlov. Full collection of compositions, Vol. III, book 2, Academy of Sciences of USSR, 1961, p. 323.

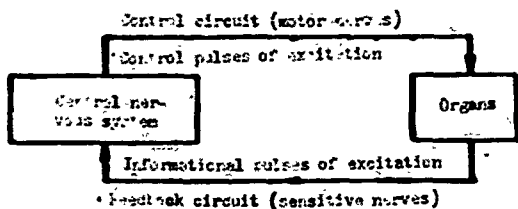

Fig. 4. Block diagram of reflector arc in a living organism.

of some stimulant (light, sound, heat and so forth) the receptor corresponds by appearance of excitation, which by feedback channel - along the sensitive nerves - spreads to the central nervous system and thus reports to it information about the influence of stimulant on an organ. In central nervous system processing of obtained information occurs. In the simplest case this is simply a transition of excitation to the motor nerves. This occurs, for instance, in the spinal cord during an unconditioned knee reflex, consisting of tossing of the leg during a hammer blow to

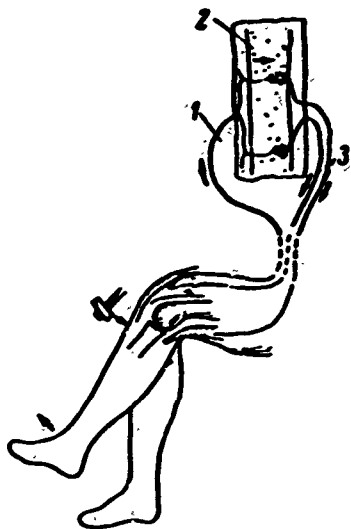

Fig. 5. Diagram of reflex arc of a knee reflex. 1 - centripetal or sensitive (afferent) nerves; 2 - spinal cord; 3 - centrifugal or motor (efferent) nerves.

technical terminology, then receptors execute the role of measuring instruments or data units. By location the receptors are divided into external (exteroreceptor), located in the skin, ears, eyes etc., and internal (interoreceptor), located in internal organs, vessels and muscles. To the action

the knee cap (Fig. 5). In more complicated cases, during conditional reflexes, the arc locks through time connections formed in the cortex of large hemispheres of the brain. From central nervous system, process of excitation along communication channels - the motor nerves - spreads to the working organs - muscles and glands, causing their activity.

By comparing now three block diagrams considered by us of control (Figs. 1, 2 and 4), pertaining to nonautomatic control, automatic control in technical device, and control in living organisms, we arrive at a conclusion concerning essential structural similarity of these diagrams and about the conformity of relations between analogous elements in the different systems.

First of all, all considered control circuits are characterized by the presence of a closed cycle, closed link chain of signal transmission, that is, transmission of information. On the one hand, from regulator to controlled object along control circuits information proceeds in the form of control signals; on the other hand, from object to regulator the transmission circuit is locked by feedback

signals, carrying information about the actual state of controlled object. Under communication channels, transmitting information, we should understand any system which is able to carry out such transmission: mechanical, pneumatic, electrical and other channels in technical devices and nervous communications in living organisms.

Role of the leader in nonautomatic control systems consists of processing the information obtained about state of the controlled object, comprehension of this information, and production of the best, most expedient decisions on object control. In systems of automatic control the role of man is transmitted to a regulator, which on the basis of obtained information, will make the corresponding "decision."¹ Instead of man, now the regulator must execute defined "logical" functions, characterized by formula "if..., then ..." (if some information is obtained, then it is necessary to render on the controlled object a certain influence). Role of the regulator belongs to organs of central nervous systems in living organisms.

Consideration of above mentioned control circuits permits making the conclusion that cybernetics as a mathematical science regarding control in the widest sense of the word should include the following main divisions.

1. Theory of systems of automatic adjustment, where basic attention of cybernetics is allotted to role of feedbacks both in technical devices and in living organisms.

2. Information theory, considering questions of information transmission along various communication channels, including the nervous system of living organisms, and processing the information in regulators, including in the organs of the central nervous system of living organisms.

3. Theory of regulators from the point of view of their ability to perform defined logical functions. Practically, at present, as the most accomplished regulators, allowing a comparison with functions of organs of the central nervous system of living organisms and man, high speed electronic computers are used. Therefore, in cybernetics theory is considered of these machines and, in the first place, theory of their fulfillment of logical processes, similar to the processes of human thinking.

¹Here and subsequently everywhere it is necessary to remember that the use of similar anthropomorphous (man-like) terminology with respect to machines is purely conditional, and serves for simplification of the account. Actually, of course machines do not "make decisions," do not "think," and do not possess a "memory" in the general concept of the word.

In cybernetics, belonging to class of exact sciences, the most important role is played by mathematical methods of investigation. Especially important for cybernetics are such divisions of mathematics as the probability theory, mathematical statistics, theory of random processes, mathematical logic, theory of algorithms, set theory, theory of functions, theory of games and investigation of operations.

Elementary questions of the theory, structure, designs, programming and use of contemporary cybernetic machines are presented in Chapters 2 and 3. Below certain initial information is given about forms of automatic devices, according to the theory of automatic adjustment, and also basic ideas from the information theory.

2. Automatic Devices

For practical realization of an automatic control system by some sort of process, certain complex of automatic devices is necessary. Depending upon concrete requirements presented to the system, these devices can be built on mechanical, electro-mechanical, pneumatic, electronic, and other elements. However, regardless of those physical principles which are assumed in the basis of construction of these devices, they can be subdivided into the following basic forms (Fig. 6): devices of automatic monitoring, automatic protection, automatic control, and automatic adjustment.

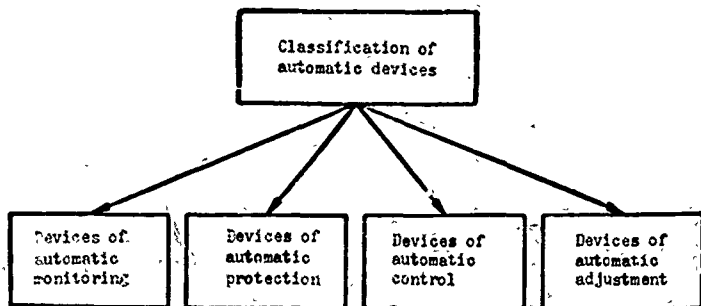

Fig. 6. Classification of automatic devices.

Automatic monitoring is a field of technology, to which pertain means and methods designed for automatic observation of the state of units and movement of an industrial process. Devices of automatic control include the means of automatic yield of different data (data units of pressure, temperature, level and others), control of dimensions and quality of the treatment of articles, all possible forms of automatic signaling, automatic measuring devices, and so forth. At the output of devices of automatic monitoring there can be different indicators (measuring scales, light signals, tableaux, sirens), self-recording registering attachments, and actuating attachments, designed for automatic sorting of articles.

Devices of automatic protection serve to automatically prevent accidents and

breakdowns, which can appear in any units due to exceeding the permissible values of currents, voltages, pressures, shifts, and so forth. Especially wide propagation has been enjoyed by devices of relay protection in power systems. At present, relay protection has been turned into an important, independent field of automation.

Devices of automatic control are the totality of technical means for automatic turning on and turning off, start, stop, change of direction and speed of any mechanisms and systems.

Automatic control is carried out especially successfully during the use of electrical drive. Here problem is considerably facilitated of smooth speed adjustment, service of corresponding mechanisms is simplified, and possibility of remote control at great distances is ensured.

Automatic adjustment is that field of automation to which pertain methods and means, ensuring support for a certain time with an assigned accuracy of defined constant parameters of the adjustable process. In a number of cases the parameters characterizing process movement must be automatically changed in time by certain previously assigned law, or depending upon flow conditions of the actual process.

3. Automatic Adjustment

Let us return once again to the block diagram of automatic control, depicted in Fig. 2. In any control system there exist so-called assigning and perturbing influences. Assigning are useful influences, ensuring the assigned operating conditions of the system. Perturbing are undesirable influences which are the consequence of a change of external conditions (temperature, pressure and so forth), load, and several other factors, which often cannot be anticipated beforehand: they are the cause of disturbance of the necessary functional connection between controlling action and adjustable magnitude. The existence of disturbances causes the necessity for the presence in systems of feedbacks and, consequently, of a closed transmission cycle of information. In general, automatic adjustment can be defined as automatic control along a closed cycle.

Assigning influences are divided into three forms: constant influence, previously undetermined influence, and, finally, influence which is a certain assigned time function. Correspondingly we distinguish three forms of automatic adjustment: stabilizing, follow-up, and programming. During stabilizing adjustment, problem of supporting some parameter of a process as constant is performed. The above considered centrifugal regulator of a steam engine constitutes one of the first systems of

stabilizing adjustment. Stabilizing systems have found wide application in supporting the constancy of speed, pressure, temperature, voltage, magnitude of current, and so forth. In radiotechnical practice, for instance, such stabilizing devices are widely applied as different stabilizers of current and supply voltage, automatic gain control in receivers, (ensuring relative constancy of voltage at output of receiver during considerable changes of voltage at the input), compressors in modulation devices (ensuring relative constancy of modulation coefficient during considerable oscillations of modulating voltage), frequency stabilization devices, and others.

In follow-up adjustment, the value of adjustable parameter is changed depending upon some other parameter, introduced from without or characterizing the flow of the very same process. Follow-up systems are widely used for remote control of different objects, when, for instance, a turn of a handle at certain angle causes a turn to the same angle of a shaft or rudder, and in telemetries, when, for instance, shift of a measured object causes corresponding shift of the pointer of a measuring instrument. Such follow-up systems, in which input and output magnitudes are mechanical shifts, are sometimes called servomechanisms. Examples of application of follow-up systems in radiotechnical practice are devices of automatic control of receivers, radar tracking systems of aircraft, and others.

Program adjustment is such a system, in which the values of adjustable parameters are automatically changed in time in accordance with the program embodied in the regulator. However, even in this case, the role of feedbacks is not lowered, since it remains a necessity of control due to the fact that the controlled object actually reacts to control signal, but consequently there is the necessity of correcting control signals in accordance with the program and with information about the actual state of the object.

According to the character of change of the adjustable magnitude, we distinguish continuous and discrete systems of automatic adjustment.

Continuous are such systems, in which a continuous change of the adjustable parameter is conditioned by continuous change of mechanical, electrical, and other magnitudes in all links of the system. Here the structure of all connections in the system remains constant, and output signals of each link constitute continuous functions of influences and time.

In discrete or intermittent systems of automatic adjustment, continuous change

of adjustable parameter corresponds to intermittent change of signals, at least in one of the sections of the system. Discrete systems in turn can be divided into relay and pulse types.

The relay is such a system, one of basic sections of which is an element of relay action (relay), ensuring intermittent change of the output magnitude during continuous changes of the input, when the latter passes through certain fixed values, called threshold.

As a simple example we will consider relay system of automatic adjustment of temperature, depicted in Fig. 7a. Such a system is applied, for instance, in thermostats of master oscillators of radio transmitters, where to ensure the constancy of generated frequency, very important is the constancy of temperature of components and the stabilizing quartz plate. Constant temperature in the thermostat is supported by heating element H. For automatic temperature control here thermoregulator is applied, which is mercury thermometer T, in the upper and lower parts of glass tube of which platinum electrodes are soldered. Upon switching on the feed to grid of tube II, through resistor R positive voltage is sent, as a result of which in anode circuit of the tube great current is established, flowing through the winding of relay P. Relay armature is attracted and locks the circuit of heating element. When temperature in the thermostat reaches a certain given value, mercury in thermoregulator reaches the upper electrode, grid of tube locks through mercury with cathode, and its potential of grid becomes equal to zero. Plate current here is considerably decreased, relay releases the contact, and preheating circuit is broken. Upon cooling of thermostat, circuit in thermoregulator breaks, relay is attracted, and again turns on the preheating.

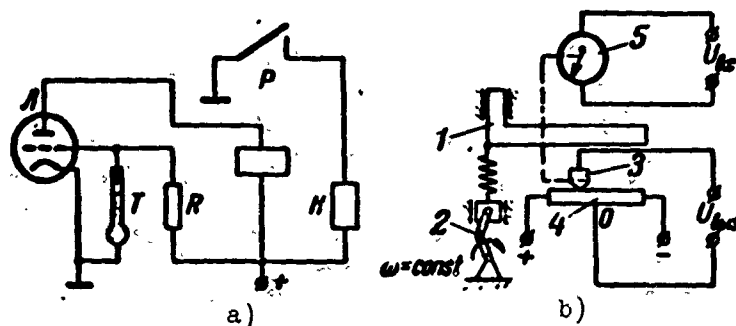

Fig. 7. Devices of automatic adjustment. a) relay system of automatic adjustment of temperature in the thermostat; b) pulse element "with incident arc."

In the described system the relay element can have two states - switched on and

off, where in the process of work it will be in a continuous oscillatory mode. Regulators of similar kind, in which there is a two-position relay element are called vibration elements.

Similarly, automatic control of speeds of electric motors is often performed. The circuit for this can be built in such a way that the centrifugal regulator, mounted on axis of electric motor, upon exceeding the assigned number of turns locks the contact, shunting additional resistor, switched consecutively into circuit of excitation winding. With this current is increased, and, corresponding so is the magnetic flux of excitation, which leads to deceleration and, consequently, the shunting contact will be opened. Speed increases again, contact locks, etc. Thus, under action of vibration regulator continuous oscillation of electric motor speed near a certain assigned value occurs.

Pulse system of automatic adjustment is that system in which the magnitude at output of one of its elements constitutes a sequence of pulses. Amplitude, duration, or frequency of following of these pulses are the function of the magnitude on element input in separate moments of time.

As an example let us consider pulse element with so-called "incident arc" (Fig. 7b). Element consists of incident arc 1, which cyclically shifts upwards and downwards with the help of drive 2, rotating with certain assigned angular velocity ω . Under the arc there is contact 3, connected with pointer of measuring instrument, 5. During shift of arc downwards, contact 3 is connected with potentiometer 4, where it locks output circuit 6. Magnitude and polarity of voltage at output of element U_{BHX} depend on position of contact 3 with respect to point 0 at the moment of touch of this contact with potentiometer. Since contact is connected with pointer of measuring instrument, voltage at the output in the end turns out to be proportional to input magnitude measured by instrument. Touching time of contact 3 with potentiometer is constant and does not depend on position of contact. Thus, duration of voltage pulses, taken from potentiometer to the output, is also constant, and amplitude and polarity of each of these pulses are determined by position of the contact with respect to median point of potentiometer, i.e., value of input magnitude.

At present, as elements which execute conversion of input magnitude into a sequence of pulses, more often different electronic circuits are being used.

Considered simplest examples pertain to systems in which stabilizing adjustment is carried out by one parameter (temperature, speed of rotation).

in systems of automatic programmed adjustment, which can replace man in the control of the most complicated industrial processes, regulator functions can be most successfully managed by High-Speed Computer, the electronic computer. Its role is to determine which control signals must be sent for the most favorable flow of the processes. Comprehensive block diagram of automatic system of programmed adjustment of an industrial process, characterized by several parameters, is shown in Fig. 9.

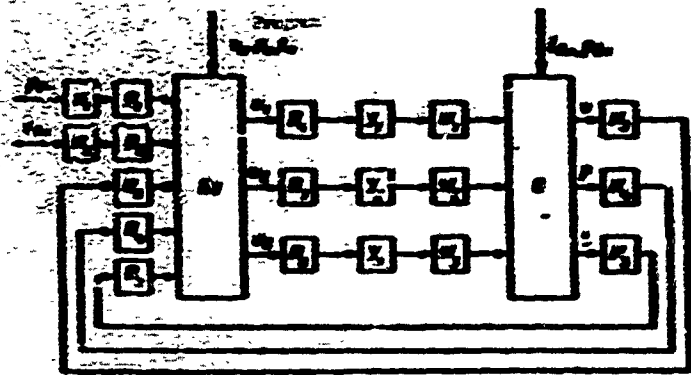

Fig. 9. Comprehensive block diagram of automatic system of programmed adjustment using a computer.

Let us assume that the work of controlled object O is characterized by the following parameters: speed v , pressures p , and temperature t . Let us assume that the assigned values by work program of these parameters are magnitudes v_0 , p_0 and t_0 . Let us assume that, finally, that the process is influenced by such external data as ambient temperature t_{amb} and atmospheric pressure p_{amb} . Then to the computer E , called upon to execute logical functions of the most favorable control of a given industrial process, there should proceed the following information. First, into it there should be introduced work program, which assigns law of change in time of values of parameters v , p and t . Secondly, into the E there should proceed information of external factors p_{amb} and t_{amb} , affecting industrial process. Magnitudes p_{amb} and t_{amb} must be measured by measuring instruments H_1 and H_2 , and their readings (after conversion by converters H_1 and H_2 into signals, convenient for lead-in) are introduced into E . Thirdly, into E there must be introduced data about the actual parameters of work of the object v , p and t , measured by instruments H_3 , H_4 and H_5 and converted into form convenient for lead-in by converters H_3 , H_4 and H_5 . In the computer processing occurs of all information obtained, where actual data are collated about work of object v , p and t with the assigned v_0 , p_0 and t_0 ; external factors p_{amb} and t_{amb} are considered, and controlling signals u_1 , u_2 and u_3 , are produced, which will be converted by converters H_6 , H_7 and H_8 into convenient form, amplified by amplifiers J_1 , J_2 and J_3 and join servomechanisms K_1 , K_2 and K_3 , influencing the controlled object in such a way, that its parameters corresponded to those assigned.

Described systems of automatic adjustment, possessing rigid characteristics, sometimes work worse than nonautomatic systems with the participation of a human operator, who can, upon necessity, by adjusting the flow of adjustable process, change the methods of control.

The successes attained in development of electronic cybernetic technology, have allowed creating so-called self-adjusting systems of automatic adjustment. In distinction from ordinary systems, where automatic control is performed by a strictly defined law, in self-adjusting systems automatic change of adjustment law takes place. In most cases this automatic change of law has as its purpose a guarantee of extreme (maximum or minimum) values of certain parameters of the adjustable process.

4. Information Theory

From that presented earlier, it follows that in the process of automatic control there occurs a transmission of different signals (information) along communication channels as well as processing of this information in regulators. Therefore, one of the most important divisions of cybernetics is the so-called information theory, which, in technical understanding, can be defined as transmission theory of information along communication channels.

Let us consider diagram of information transmission along communication channel shown in Fig. 9. Information produced by the source and subject to transmission

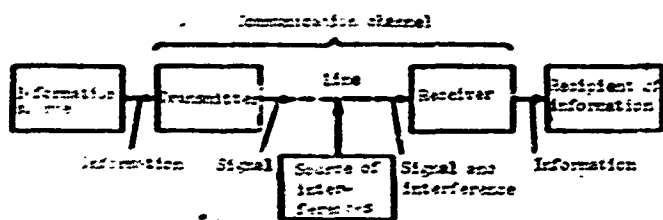

(human speech, music, text of a telegram, an image and so forth) must be preliminarily turned into an electrical signal which is convenient for transmission along the line. This conversion occurs in the transmitter, to which we will refer

Fig. 9. Diagram of information transmission along communication system.

a microphone, telegraph key, a transmitting television tube and other converters of information into electrical signals, and also the necessary high frequency oscillators, modulation devices, amplifiers, and so forth. From the transmitter the signal enters line (wire, cable, radio link) and spreads along it to the receiver, in which there occurs inverse transformation of the signal into information delivered to the recipient. Transmitter, line, and receiver form the communication channel. During transmission along communication channel absorption and distortion of signal

occur, and, furthermore, sources of interferences mix interferences with signal which in the end also hinder correct reproduction of information on the receiving end. Basic problems which stand before the information theory are first, the question about the most productive use of the channel, i.e., how to transmit the greatest quantity of information along channel, and, secondly, question about reliability of communication, i.e., the ability of the communication system to deliver information to recipient with minimum losses and distortions.

Let us first consider the question about efficiency of using the communication channel. Role of communication channel consists of transporting information from source to recipient. Therefore, from the point of view of transmission technology, it is necessary to find such properties of signals by which it is convenient to characterize conditions of their movement along the channel. It is possible to conduct a certain analogy between transporting signals along channels and loads along means of communication. From the point of view of shipment technology, we are by far interested in all characteristics of the load. Thus, for instance, from the point of view of the transport worker, such characteristics are very important as load weight and its size (dimensions). However, for instance, the color of this load does not affect the technical conditions of its transport. Similar to this, the signal can be characterized by certain basic parameters (properties), having the greatest value during its transmission along the channel.

Such signal properties are obviously its magnitude or intensity, and the frequency band occupied by the signal, since these parameters determine the corresponding requirements for the communication channel. Another important characteristic is the signal duration, determining holding time of the channel. At the same time the meaning of the information contained in the given signal plays no role from the point of view of transmission technology. Transmission of the information "terminal stage of powerful amplifier broke down" or "on Monday meet the twentieth train, railroad car 11" requires identical time and identical expenditures of electrical energy, since each of these reports contains an identical quantity of letters, although they sharply differ from each other in meaning.

Let us stop more specifically on the basic (from the point of view of transmission) characteristics of the signal. Most important is the signal intensity, expressed by its electrical power. However, since practically the properties of the signal as a carrier of information are not determined by its absolute magnitude, but by going beyond the level of the signal above level of interferences, then as a

standard of signal intensity we select the relation of signal power p_c to power acting in interference channel P_{Π} . Here, to obtain a more convenient mathematical relationship we take not the absolute value of this relation, but its logarithm. Thus, magnitude of signal excess over interference, or relative average level of signal over interference,

$$H = \log \frac{P_c}{P_{\Pi}}$$

Following parameter of the signal is the width of its spectrum, F , constituting the difference between maximum and minimum frequencies available in signal spectrum:

$$F = f_{max} - f_{min}$$

Finally, signal is characterized by duration T , equal to difference between cessation time (end) of signal t_K and time of its beginning t_H :

$$T = t_K - t_H$$

If one were to imagine the signal characteristics which we selected in the form of segments of straight lines, expressed in a defined scale, and to place these segments parallel to three mutually perpendicular axes of coordinates: axis of relative levels h , axis of frequencies f , and axis of time t , then it is possible geometrically to imagine the signal in the form of the volume of a parallelepiped with ribs H , F and T , constituting the dimensions of the signal (Fig. 10). Product $V = HFT$ will be called volume of the signal.

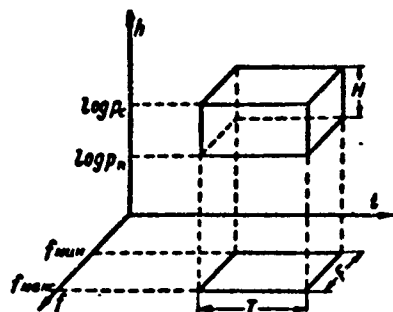

Fig. 10. Geometric representation of the signal.

By analogous parameters we can characterize the communication channel. Let us designate by H_K the permissible range of changes of power in the channel, and by F_K the spectrum width of frequencies, passed by the channel, and by T_K the busy period of the channel. Then properties of the channel on the whole can be characterized by product $V_K = H_K F_K T_K$, which will be called capacity of the channel.

¹This expression for H is convenient to use when the signal considerably exceeds the interferences. More exact is the expression

$$H = 2 \log \left(1 + \frac{U_c}{U_n} \right)$$

So that channel ensured transmission of a given signal, it is necessary to observe condition $V_R \geq V_C$, i.e., so that signal volume fit in channel capacity. Capacity of effective communication channels is usually greater than volume of signals transmitted along it, and to increase efficiency of channel use it is necessary, by applying corresponding signal conversion methods, to seek as large as possible an approximation to equality $V_R = V_C$. Transmission of signals in communication system is not an end in itself. In the end we are interested not in transmission of signals, but in transmission of information; signals are only convenient for the transmission by form, into which information will be converted. Therefore, problem of effective use of a communication channel also requires maximum filling of signal volume by transmitted information or reports.

However, if we relatively lightly dealt with measurement of signal volume and channel capacity, then the measurement of quantity of reports or amount of information is a more difficult problem, especially considering the qualitative uniqueness of different reports (literal text, speech, music, image) and the necessity of finding such a unit of measurement which would turn out to be useful for the measurement of these qualitatively different forms of information. After prolonged searches for the unit of information it was agreed to accept the so-called binary digit, which is a quantity of information obtained as the result of single selection from two equiprobable possibilities. Let us examine this determination.

We assume that we have a box, into which we placed two white spheres. Let us now extract one of the spheres. Certainly, this sphere will be white, and nothing new (as a result of such an experiment) will be recognized. Since we knew beforehand that we would extract a white sphere, then, removing it, we do not obtain anything new, no information. Quantity of information obtained as a result of the experiment which we performed is equal to zero.

Let us now lower into the box one white and one black sphere. Now we no longer can predict beforehand what color the sphere will be which we will remove from the box. The probabilities of extracting a black or white sphere are absolutely identical, and, thus, extracting this or that sphere, i.e., performing a single selection from two equiprobable possibilities will be recognized as something previously unknown, and we will obtain certain information, the quantity of which was agreed to be accepted as equal to one binary digit.

Let us now assume that we lowered into an urn 32 tickets with different letters

of alphabet written on them. If tickets are well mixed, then probability of extracting any one of tickets is identical. Let us try to calculate in binary digits the quantity of information which we will obtain when extracting one of the tickets. For this it is necessary to reduce the process of detecting a defined ticket to a series of single selections from two equiprobable possibilities. This is possible so. Let us divide all tickets into two equal groups of 16 tickets each. Ticket interesting us will appear in one of these groups. That group where the desired ticket is absent, will be placed aside, and the remaining we will divide by two. Now, as a result of second experiment, the necessary ticket will appear in one of the groups of eight tickets. We will perform such selections from two equiprobable possibilities until in the group there remains only the one ticket which interests us. It is not difficult to calculate that this will be obtained as a result five selections from two equiprobable possibilities. Hence conclusion can be made that quantity of information, obtained as a result of extraction of one of 32 equiprobable tickets, will be equal to five binary digits. In general it is easy to show that with such an approach to measurement of information, the quantity of information I , obtained during accomplishment of one of n equiprobable events, will be equal to logarithm of the number of these events, taken at base 2:

$$I = \log_2 n.$$

Everything said until now pertains to information obtained as a result of the fact that one of several equiprobable events is accomplished. However, in real cases of information transmission along communication channels as a rule we deal with events of unequal probability. Thus, for instance, during transmission of telegraph text in the Russian language, probability of obtaining the letter O is considerably greater than probability of obtaining the letter H, since in Russian text O is encountered approximately 6 times more frequently than H. Comparatively simple conclusion permits determining information I , pertaining to one letter of the alphabet of a language, characterizing a defined distribution of probabilities of the appearance of separate letters:

$$I = -(p_1 \log_2 p_1 + p_2 \log_2 p_2 + \dots + p_n \log_2 p_n) \text{ binary digits.}$$

In this expression p_1, p_2, \dots, p_n constitute the probability of appearance of each of n letters in a given language. Let us remember that probability p of

some event is called the relation of the number of events interesting us to total amount of events accomplished in a sufficiently large total amount of events, i.e., in a mass character of operations. For instance, in order to determine the probability of appearance in a text of a given language of the letters a, b etc., it is necessary to take some book, printed in this language, calculate the total amount of letters in the text, n , and quantity of letters a (n_a), b (n_b) etc. Then probability of letter a will be $p_a = n_a/n$, and probability of letter b will be $p_b = n_b/n$, etc.

Probability of any event p is always smaller or is equal to one ($p < 1$). Probability of a reliable event is equal to one (such, for instance, as the probability of extracting a white sphere from the urn, filled only with white spheres). Probability of an impossible event is equal to zero (for instance, probability of extracting a white sphere from an urn filled only with black spheres). It is still necessary to stress that results of determination of probabilities close to truth can be only obtained in the analysis of sufficiently mass operations. Thus, for the determination of probabilities of the appearance of letters in a text it is possible to take any sufficiently thick book in a given language, and the results here will practically coincide. However, if we try to determine the probability of letters by analyzing only one page of the text, the results obtained will be different, and in the analysis of only one line, absolutely untrue results can be obtained. After all, if in this line we assume that the letter d was totally absent, then we will find that its probability $p_d = 0$, i.e., we will make the absurd conclusion that the appearance of letter d in Russian text is an impossible event.

Above we described a method convenient for the measurement of so-called discrete information, i.e., information, composed from a sequence of separate (discrete) elements, letters. Text of a report, transmitted by telegraph, is a typical example of discrete information. However, transmission of continuous information considerably more frequently occurs, a typical example of which is the transmission of a telephone report. Really, the current in a telephone circuit is a function which is continuously variable in time (Fig. 11). A continuous function of time is the television signal. Such a function, in general, in a finite interval of time from t_1 to t_2 can be completely exactly expressed only by an innumerable set of values, i.e., an infinite quantity of numbers, corresponding to instantaneous values of the function. However, practically, we always deal with functions limited by spectrum.

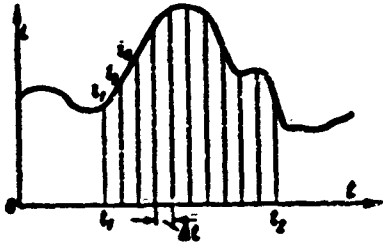

Fig. 11. Graph of continuous time function.

Any function of complicated form of a sum of sinusoidal oscillations of the basic frequency and a number of harmonics, where the spectrum of audio-frequencies is limited by the highest frequency near 10 kilocycles, and in telephone communications by a frequency of about 3-5 kilocycles.

For such functions V. A. Kotel'nikov proved a very important theorem, stating that a function with a frequency spectrum, limited by highest frequency f_B can be completely exactly represented by a finite number of separate values i_1, i_2, i_3, \dots , counted off through time intervals

$$\Delta t = \frac{1}{2f_B}$$

Theorem of V. A. Kotel'nikov allows, thus, presenting the continuous information in the discrete form, and, in particular, to spread to the continuous information methods of determining its quantities, based on the measurement of the quantity of discrete information. On the basis of this theorem there have been developed practical methods of so-called signal quantization, i.e., transmission of a continuous signal in the form of sequence of its discrete values, which is most widely used in different forms of pulse modulation.

Important in information theory is the idea regarding excess. For a elementary understanding of this idea we will conduct the following reasoning. In the Russian alphabet there are 32 letters. If one were to limit the length of a word to one letter, then the maximum quantity of possible words when using this alphabet would also be 32. If one were now to set the word length at two letters and assume that any, differing from another combination of two letters (including and identical), is a significant word, then the quantity of possible words will already be $32^2 = 1,024$ words. Finally, at word length of three letters, the quantity of possible words composed by such a principle will already be $32^3 = 32,768$ words, i.e., considerably greater than we use in dialy speech.

At the same time, average word length in the Russian language is about 6 letters. Consequently, all our written texts, spoken language, telephone reports, and so forth, are approximately two times longer than they could be with the use of a more economic method of encoding, i.e., for natural language a considerable excess of encoding is

characteristic.

However, in spite of the economic disadvantage of encoding excess, it has its essential merits. The fact is that with economic encoding, when each, for instance, trigraphic combination corresponds to a defined new idea, any error, i.e., an accidental replacement of one letter by another will lead to the formation of a new word, corresponding to a new idea. At the same time the complicated system of encoding ideas in oral and written language enables us as a rule, not only easily to reveal, but also to correct similar errors. Thus, if we read or heard the word "oshabka," "izbytchnost'," "kodiobaniye," and others, then without special difficulty we would understand that these are distortions of the words "oshibka," "izbytochnost'," and "kodiobaniye,"

The same pertains to the problem of correct identification of images and other objects — the greater the quantity, one would think, of immaterial objects, not determining the essence of given object, but nonetheless criteria usually peculiar to it, more errorfree would be the identification of this object.

On the basis of achievements of the information theory, at present there have been developed a number of greatly improved encoding methods of reports. This permits achieving the most complete use of communication channels, and also to increase considerably reliability of information transmission. In particular, there have been developed new modulation methods, the so-called correlation method of reception, which allows separating the useful signal in the presence of level of interference exceeding it, special correcting codes, i.e., codes, permitting revealing and correcting errors appearing and others.

5. Calculation Systems

One very important questions, both from the point of view of communication, as well as from the point of view of work of electronic computers is the question of the simplest, most convenient, and most accomplished methods of encoding magnitude.

Any magnitude is usually represented (encoded) in the form of a number; worldwide propagation has been obtained by now so-called decimal system, based on the use of ten figures 0, 1, 2, 3, ..., 9 and initially appearing as the result people using the ten fingers of their hands for counting. However, decimal system is not at all the only possible system. In various time, various, various peoples have used different number systems. Thus, for the ancient Indians of Maya tribe icosal number system was applied in which after units followed not ten, but twenties and after tens

not hundreds, but fourhundreds (twenty twentieths). Even now remainders of icosal number system are found (counting by dozens, grosses, i.e., a dozen dozens, etc).

For an expression of numbers in the icosal system it is necessary to arrange by twenty, and in duodecimal, - by twelve figures. Systems are possible also with a considerably smaller quantity of figures. Thus, in the most primitive unit system it was sufficient to have only one figure 1, with the help of which it is possible to express any number in the following way.

Decimal system	1	2	3	4	...	8
Unit system	1	11	111	1111	...	11111111

It is possible to construct a quinary (with five figures), ternary (with three figures), binary (with two figures), and an infinite number of other number systems.

Let us establish certain general laws of the construction of position number system, i.e., systems in which the value of each symbol (figure) is determined not only by its outline, but also its position in the number (position). For this we will consider (first of all) the most wide-spread decimal system.

In decimal system, any number N can be represented in the form of a sum of products of different degrees of ten in coefficients, which can take one of ten possible values.

In reduced form this can be written so:

$$N = \sum_{i=1}^{i=n} k_i \cdot 10^{i-1}$$

where $k_1 = 0, 1, 2, \dots, 9$, and n - is quantity of digits in a number. For instance, the four-digit number 7,405 can be shown the form of a sum: $7,405 = 7 \cdot 10^3 + 4 \cdot 10^2 + 0 \cdot 10^1 + 5 \cdot 10^0$. Here $k_1 = 5$, $k_2 = 0$, $k_3 = 4$ and $k_4 = 7$.

For simplification of recording the number we write only the values of these coefficients 7, 4, 0, 5, placing them from left to right by diminishing indices. Here we remember that if coefficient stands in the first place to the right, then it signifies the quantity of tens in the zero degree, i.e., the quantity of units, but if it stands, for instance, in the fourth place on the right, then it signifies the quantity of tens in cube, i.e., the quantity of thousand, etc.

In general, in any position number system, certain quantity a of units of first digit (where a is called the base of system of calculation) are joined in one unit of the second digit, a units of the second digit is joined in one unit of the third digit, etc. Thus, any number N in a position number system with base a is

expressed in the form:

$$N = \sum_{i=1}^n k_i a^{i-1}$$

where i is ordinal number of digit, but k_i is coefficient which can take a different values: 0, 1, 2, ..., (a-1). When recording numbers, for simplification only value of coefficients k_i are written which are placed from left to right by diminishing indices.

Of greatest interest for communication, telemechanics, telemetries, and especially for computer technology, is the binary number system, in which any number can be recorded by placing only two figures, 0 and 1. In binary number system the overwhelming majority of contemporary high speed electronic digital computers works.

In accordance with the general recording formula of numbers in position number systems, any number in the binary system can be recorded in the form

$$N = \sum_{i=1}^n k_i 2^{i-1}$$

where k_i can take only two values: 0 or 1. For instance, number 21 in binary system can be shown in the form of the sum:

$$21 = 1 \cdot 2^4 + 0 \cdot 2^3 + 1 \cdot 2^2 + 0 \cdot 2^1 + 1 \cdot 2^0$$

Recording this number by the same principle as in the decimal system is possible in the form of consecutively located coefficients with corresponding degrees, i.e., in the form

$$21 \rightarrow 10101$$

This recording when reading is deciphered thus: once $2^0 = 1$; not once $2^1 = 2$; once $2^2 = 4$; not once $2^3 = 8$; once $2^4 = 16$. Altogether, $16 + 0 + 4 + 0 + 1 = 21$.

We will give comparative recording of simplest numbers in decimal and in binary systems of calculation (Table 1). For fast translation from decimal system into binary it is possible to use the following rule. It is necessary to write in the in column the number in decimal system and the results of its in series division by 2 (with rounding to integer) towards decrease, then opposite every odd number to

Table 1

Numbers recorded in number systems		Numbers recorded in number systems		Numbers recorded in number systems		Numbers recorded in number systems	
decimal	binary	decimal	binary	decimal	binary	decimal	binary
0	0	5	101	10	1010	15	1111
1	1	6	110	11	1011	16	10000
2	10	7	111	12	1100	17	10001
3	11	8	1000	13	1101	18	10010
4	100	9	1001	14	1110	19	10011

place 1, and opposite each even number place 0, and unit and zeroes obtained in order of from bottom to top will be recorded in line from left to right.

Let us illustrate this rule by example of recoded number 7405 from the decimal system in binary. We divide it by 2 and obtain 3702.5, but rounding it to an integer towards decrease, we record 3702, again divide by 2, record 1851, etc., until we obtain 1.

7405		1
3702		0
1851		1
925		1
462		0
231		1
115		1
57		1
28		0
14		0
7		1
3		1
1		1

Then we write opposite the odd numbers ones, and opposite the evens we write zeroes, and record the obtained binary number 1110011101101, which actually, as a result of checks turns out to be equal to decimal number 7405.

Let us compare (from the point of view of machine count) the binary considered number system which we considered with the decimal. Equivalent numbers have in the binary system 3-4 times greater amount of digits than in the decimal system. In our example the four-digit number 7,405 in binary system is depicted by thirteen-digit number 1110011101101. This is a deficiency of binary system. However, here the numerical certificate is considerably simplified. Instead of ten figure-symbols, 0, 1, 2, 3, 4, 5, 6, 7, 8, and 9, necessary for depicting numbers in the decimal system, any number in binary system is expressed by using only two symbols: 0 and 1.

Let us compare the possibility of depicting (encoding) a number in the form of voltages or currents with different number systems (Fig. 12). Any number can be encoded and transmitted in so-called infinite number system, in the form of a voltage pulse or current, proportional in magnitude to this number. Thus, number 7,405 can be encoded by voltage pulse with amplitude of 7,405 v.

In decimal number system it is possible to encode in the form of a sequence of four pulse, the first of which will have voltage of 7 v, the second 4 v, the third v, and the fourth 5 v. Let us assume now that amplitude of pulses is lowered by

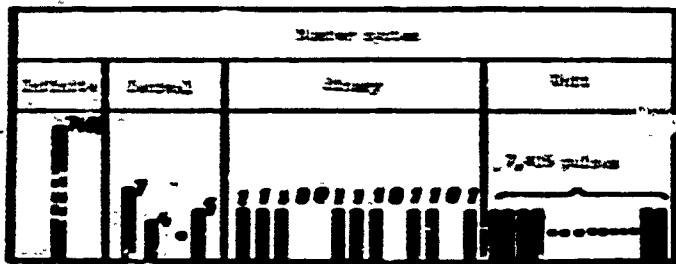

Fig. 12. Encoding of number 7,405 in different number systems.

1% due to lowering the voltage of power supplies, or due to the effect of α in the transmission circuit. Then in the first case voltage of pulse 7,405 v will be lowered to $7,405 - 74.05 = 7,330.95$ v, and thus we will obtain not that number which we wanted to transmit (error during transmission will also be 1%). If by 1% we decrease the amplitude of pulses during encoding by the decimal system, then, since pulses depict only integers, we obviously will be able by magnitude $5 - 0.05 = 4.95$ v to guess that by means of rounding that the given pulse depicts the number 5. Thus, decimal system ensures somewhat more reliable encoding of information. However, this increase of reliability takes place only when a change of amplitude of pulses does not exceed several percent.

In binary number system, number 7,405 is recorded in the form 111001110111 and can be encoded in the form of a sequence of 11 pulses, where the pulses, corresponding to units, can have any, let us say, positive value, but pulses corresponding to zeroes, must have amplitude equal to zero, or can have any negative value. Low oscillations of feed sources or a change of amplitude of the pulses during transmission, even by tens of percents will in no way affect the authenticity of information, since during binary encoding we were interested not in magnitude of pulse, but the fact itself its existence: if there is a pulse, it means that one is recorded, and if there is no pulse, zero is recorded.

Finally, in unit number system the number 7,405 can be represented in the form of a sequence of 7,405 pulses of any amplitude. Thus, in authenticity the unit system does not yield to the binary, but it is extremely inconvenient, since large numbers represent a large quantity of pulses and this means that they require very long time for recording and transmission.

By comparing the properties of encoding in the four number systems which we considered, it is possible to give unconditional preference to the binary system, with which (on the one hand) the highest authenticity of information is ensured, and, on the other hand, recording and transmission of numbers, although more prolonged than during all other (besides unit) systems, still occupy a fully acceptable time length. At pulse duration on the order of microseconds, the overall time

1% due to lowering the voltage of power supplies, or due to the effect of α in the transmission circuit. Then in the first case voltage of pulse 7,405 v will be lowered to $7,405 - 74.05 = 7,330.95$ v, and thus we will obtain not that number which we wanted to transmit (error

necessary for transmission of a number does not exceed tens hundreds of microseconds.

From the viewpoint of machine computer technology, encoding by the binary number system possesses a very significant advantage, since it permits constructing machines from simple elements with two stable states: two-position electromagnetic or electronic relays, magnetic elements with rectangular hysteresis loop, and so forth. Such elements are considerably more simple and more reliable than elements with ten stable states. This advantage can be realized in machines by conditionally considering that one of the stable states, for instance the initial, corresponds to zero, and the second, the working state, corresponds to one. Finally, a very important advantage of binary system is the extreme simplicity of the rules of fulfillment of arithmetical operations. Really, for addition of numbers in the binary system it is necessary to know only the following rule (table of addition):

$0+0=0$
 $0+1=1$
 $1+0=1$
 $1+1=10$

The last line must be deciphered thus: 1 + 1 will give in sum 0, and in transfer to following digit, 1.

Table of multiplication in the binary system appears so:

$0 \times 0 = 0$
 $0 \times 1 = 0$
 $1 \times 0 = 0$
 $1 \times 1 = 1$

Technical rules of fulfilling arithmetical operations remain in the binary system the same as in the decimal. Let us produce, for instance, addition and multiplication in binary system of numbers 5 (101) and 9 (1001):

$$\begin{array}{r} + 5 \rightarrow 101 \\ + 9 \rightarrow 1001 \\ \hline 14 \rightarrow 1110 \end{array}$$

$$\begin{array}{r} \times 5 \rightarrow 101 \\ \times 9 \rightarrow 1001 \\ \hline 101 \\ 000 \\ 000 \\ 101 \\ \hline 45 \rightarrow 101101 \end{array}$$

By general rules it is possible in the binary system also to execute both subtraction and division. However, practically, proceeding from the problem of the simplification of devices and unification of arithmetical operations, all operations of arithmetic in digital computers attempt to be reduced to one — addition.

In binary number system, as can be seen from given example, multiplication naturally leads to addition of the multiplicand with itself as many times as there are ones in the multiplier, only with simultaneous realization of shifts of these components to the left.

By applying certain artificial methods it is possible to bring also subtraction of numbers to addition. Finally, division can be performed by subtracting the divisor from the dividend. Thus, all four arithmetic operations can be replaced by addition. Since different, more complicated calculating operations in turn lead to simple arithmetic operations, then the possibility appears, by using only the operation of summation and certain simple auxiliary logical operations, of solving complicated problems of a computational native.

CHAPTER II

ELECTRONIC COMPUTERS

6. General Information about Computers

Rapid development of science and technology requires the realization of continuously increasing quantity of more and more complicated and labor-consuming calculations and computations. Humanity for a long time has used all possible computing instruments, facilitating this calculating work. Such instruments include ordinary office calculators, slide rules, adding machines, all possible calculating and perforating machines of mechanical action, electronic analog and digital computers. All these various computing instruments can be divided into two basic groups: analog and digital calculating instruments and machines.

In analog instruments the numbers, with which all possible operations are produced are simulated by certain physical quantities. Classic example of analog instrument can be such widely used computing device as the slide rule. Here numbers are simulated by lengths. In producing these or those operations on the slide rule we actually add or subtract defined sections of length of the body and slide, on which (in logarithmic scale) numbers are written.

Numbers can also be simulated by angles of rotation of a shaft, pressures, currents, voltages, and so forth. Let us imagine an adder circuit (Fig. 13), consisting of two potentiometers R_1 and R_2 , with the help of which we can establish voltages U_1 and U_2 , corresponding to the components and measured by voltmeters V_1 and V_2 . Then voltmeter V will show us voltage $U = U_1 + U_2$, i.e., voltage, corresponding to the sum. Thus we will immediately obtain a ready answer, the sum. By applying relatively simple tube circuits, it is also possible to carry out rapidly simple arithmetic operations, trigonometric operations, integration and so

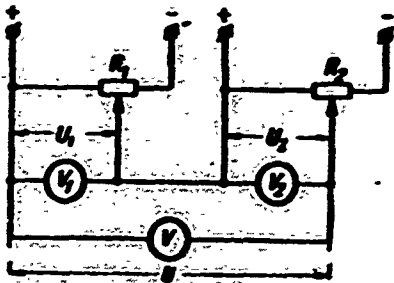

Fig. 13. Simplest electrical adder circuit on potentiometers.

forth.

The main merit of analog computers is their high work speed, ensuring solution of complicated mathematical problems during the time of seconds or even fractions of a second. However, analog computers also possess a serious deficiency — comparatively low accuracy of calculations. It is known, for instance, that during calculations on a slide rule we obtain 2-3 exact signs in all. In

electrical and electronic analog machines the accuracy of calculations is influenced by interferences and oscillation of voltage of the power supplies. Finally, in general, in conditions of rapid work it is difficult to establish exactly and to measure exactly the voltage or currents with high accuracy. Therefore, practically, electronic computers give errors on the order of units of percents. Another deficiency of the analog computers is their specialized character: diagram and arrangement of the machine ensure solution of problems of a defined type: for solution of problems of another type it is necessary to use another machine.

The described properties of analog computers determine also the field of their use in solutions of engineering problems, problems of a military character (firing, bombing, and others) and other problems, for which the accuracy on the order of units of percents is sufficient, and at the same time, high work speed and simplicity of exploitation are required.

Digital computers work on the principles of by-digit count. Widely-spread simplest digital devices are office calculators and adding machines. Work accuracy of these instruments in principle is not limited: It is conditioned only by their construction, i.e., the quantity of wires with balls in the abacus and quantity of digital wheels in the adding machines. Namely this property of digital devices — high accuracy of calculations — conditions their exceptional use in bookkeeping works. The zenith of contemporary computer technology are the electronic digital computers, enabling us to carry out calculations with high speeds, attaining at present a million arithmetical operations per second, and with accuracy on the order of tens of correct signs. The most important positive property of electronic digital computers is also their universality. The same machine can solve the most varied calculating and logical problems, and, consequently, electronic digital

computers open wide prospects of mechanization of mental labor. The future of cybernetics is intimately connected in the first place with the development of digital computers; therefore, we will subsequently concentrate our basic attention on their arrangement and work.

Let us consider a simplified block diagram of electronic computer (Fig. 14). In this diagram only basic units of machine are shown and their connections among

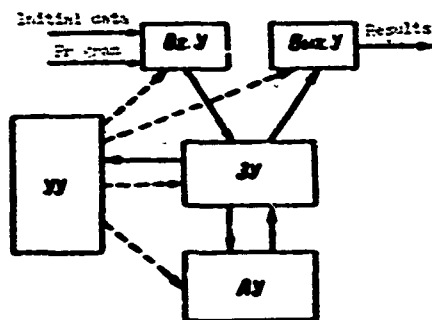

Fig. 14. Block diagram of electronic digital computer. $Bx.y$. Y - inlet; $Bx.y.Y$ - output device; YY - control system; ZY - memory unit; AY - arithmetic unit.

themselves. The most important parts of the machine are memory, arithmetical and control systems. The memory unit, [MU] (ZY), or (shorter) the "memory" of the machine serves as more or less prolonged storage of information, introduced into the machine, and intermediate and final results of calculations performed by machine. In arithmetic unit, [AU] (AY), there occur arithmetical operations on numbers corresponding to program which enter into it from MU, where results of these operations

return to "memory" of the machine and are fixed in it. Finally the control system, [UU] (yy), serves control of all elements of the machine in accordance with program introduced in it.

Through inlet [IU] ($Bx.Y$) lead-in into the machine of initial data and program of calculations takes place, while through output devices [OU] ($Bx.Y$) the outlet of the final, and in a number of cases the important intermediate results of calculations from machine takes place. Circuits of information transmission (numbers, program) are shown on diagram by solid lines, and control circuits are shown by broken lines. Thus, if by program the machine must execute an operation of addition of two numbers, then then the control system will prepare AU for execution of addition, and memory unit will issue numbers into AU which subject to addition. Sum from AU will proceed again to MU, and if it is the final result, then from ZU it will enter output device and will be printed.

Subsequently we will show how each of the devices of the machine works. However, since the arithmetical, memory, and controlling devices, as a rule, include electronic elements with two stable states (bistable or two-position elements) of so-called trigger type or trigger circuits, we will give first of all certain

information about the work of triggers and their application in circuits of cybernetic machines.

7. Triggers and Their Application in Cybernetic Technology

There exists a large quantity of diverse variants of trigger circuits. In Fig. 15 one of simplest variants is represented of trigger circuit on two triodes. Circuit is a two-tube amplifier with positive feedback. At first glance it seems that with full symmetry of all elements of the circuit it will be in state of

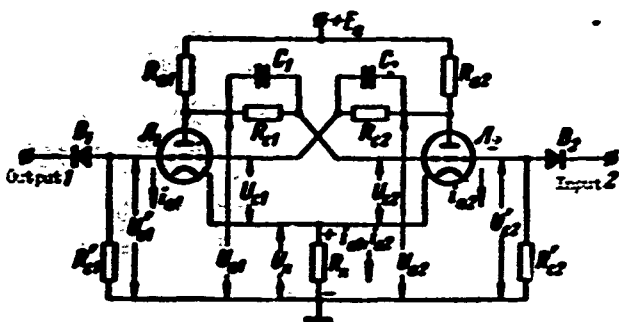

Fig. 15. Diagram of a trigger on triodes.

equilibrium and currents in both tubes i_{a1} and i_{a2} will be identical. However, during more detailed consideration of circuit it turns out that this equilibrium is unstable. Like a pencil, even with ideal vertical setting of it on the point, will fall by action of some random cause (concussion, puff of wind, and so forth), we cannot beforehand

predict to which side the trigger (if left to itself) would cross to one of two stable states, at which the current in one tube will reach a certain maximum, and in the second a minimum, magnitude.

Actually let us imagine that by some random cause current i_{a1} in tube J_1 was at least insignificantly increased. This immediately will lead to an increase of voltage drop on resistor R_{a1} , and consequently, to a decrease of voltage U_{a1} on anode of the first tube. But since grid voltage of the second tube U_{c2} is composed of negative voltage drop U_k on resistor R_k and positive voltage drop U'_{c2} on resistor R'_{c2} , where U'_{c2} is proportional to U_{a1} $(U'_{c2} = U_{a1} \frac{R'_{c2}}{R_{c1} + R'_{c2}})$, then decrease of voltage U_a will lead to a drop of potential U_{c2} on grid of tube J_2 , and it means, also to a decrease of current i_{a2} . But a decrease of current i_{a2} will lead to decrease of voltage drop on resistor R_{a2} , an increase of voltage U_{a2} on anode of tube J_2 , and increase of potential U_{c1} of tube grid J_1 , since U_{c1} depends on U_{a2} $(U_{c1} = U_{a2} \times \frac{R_{c1}}{R_{c2} + R_{c1}})$. Increase of potential U_{c1} will cause a further increase of current i_{a1} , lowering of potential U_{a1} , decrease of current i_{a2} , etc.

During corresponding selection of elements of the circuit this process will grow in the avalanche method and will be ceased, when current i_{a1} in the first tube reaches certain greatest value, and tube J_2 will be locked by negative voltage

$U_{c2} = -U_k + U'_{c2}$. Similar state is stable and will be maintained until to input 1 negative volgate pules will be sent. This pulse will cause sharp lowering of current i_{a1} , and this means an increase U_{a1} and U'_{c2} , which will lead to unlocking of the second tube, an increase of i_{a2} , a decrease of U_{a2} , lowering U'_{c2} and, in the end, to an avalanche-type process, as a result of which the trigger will cross to a new stable state, characterized by the fact that tube \bar{J}_1 is locked, and current in \bar{J}_2 reaches the greatest value. To return the circuit to first position it is now necessary to send negative pulse to grid of second tuve (to input 2). Capacitors C_1 and C_2 facilitate acceleration of trigger transfer from one stable state to another. Trigger circuit is usually not gathered on two separate tubes, but on two halves of one double triode, or pentode.

We will now supplement our considered circuit in accordance with the needs of computer technology (Fig. 16). Let us join both inputs among themselves, as a result of which there will be formed one common input; we will make a tap from anode of tube \bar{J}_1 and will call it the trigger output, and we will join grid of tube \bar{J}_2

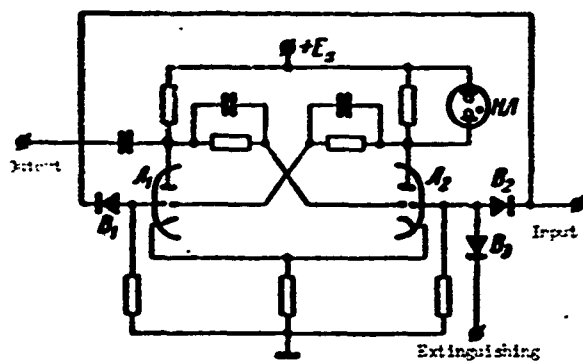

Fig. 16. Diagram of a trigger as an element of a counting circuit.

through valve $[V_3]$ (B_3) with one more input, which we will call extinguishing input and we will connect in parallel to resistor R_{a2} the neon tube $[NL]$ ($[H]$), which, obviously, will burn only when the current i_{a2} reaches a great magnitude and creates on resistor R_{a2} a sufficient voltage drop. Let us agree to consider as the initial state of the trigger that when the current in the first tube is

the greatest, and second tube is locked, and will allot to this initial state the value 0. Second state, when first tube is locked, but current in second tube is the greatest will be called the worker, and will be allotted value 1. Criterion of working state of the trigger is the burning of neon tube H .

Negative pulse, sent to common input, arrives at the grids of both tubes, however, in locked tube it causes no changes, but in an open tube the current drops rapidly and trigger will cross to the second stable state. Thus, supply of negative pulse to input of extinguishing, it arrives only on the grid of tube \bar{J}_2 , since valve

V_2 does not pass it to tube Π_1 and, consequently, trigger transfers to initial state. During transition from initial state to working, potential on anode of tube Π_1 is sharply increased which leads to the appearance at the output of the trigger of a positive pulse. During transition from working state to initial, potential U_{a1} sharply drops and at output of trigger there appears a negative pulse.

Let us now consider how from several triggers it is possible to compose a circuit of a pulse counter. For registration of the number of pulses which is expressed in the binary number system by n-digit number, the counter must have n triggers. Block diagram of the counter is shown in Fig. 17, where every trigger

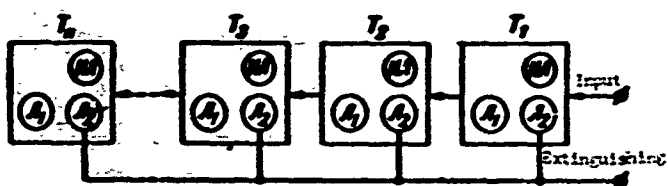

Fig. 17. Block diagram of a counter on triggers.

T_1, T_2, \dots, T_n is shown in simplified form of a rectangle with two inputs (for working pulses and pulses of extinguishing), one output, two tubes Π_1 and Π_2 , and neon tube NL. Counter is designed for fixation of the quantity

of negative pulses proceeding to its input. Upon entry of the first pulse, trigger T_1 passes to the working state, from which tube NL is lighted, and to input of trigger T_2 positive pulse, is sent, which does not change its state, since valves V_1 and V_2 (Fig. 16) do not pass positive pulses into the circuit. Thus, after the first pulse, a state will be established characterized by the first line of Table 2.

Second negative pulse will

move trigger T_1 into initial state, its neon tube will go out, from it to trigger T_2 negative pulse will proceed, which will transfer the latter to the working state (second line of Table 2). Third pulse will cause a transition of trigger T_1 to the working state, fourth pulse will cause a transfer of it to the initial state, where negative pulse will be issued to

Table 1

Number of pulses	State of triggers:						Number fixed by counter	
	T_1	...	T_2	T_3	T_4	T_n	in binary number system	In decimal system
1	○					●	0...0001	1
2	○					○	0...0010	2
3	○					○	0...0011	3
4	○					○	0...0100	4
5	○					○	0...0101	5
6	○					○	0...0110	6
7	○					○	0...0111	7
8	○		○			○	0...1000	8
9	○		○			○	0...1001	9
10	○		○	○		○	0...1010	10

trigger T_2 , which also will cross to the initial state and will issue negative pulse to trigger T_3 , which will cross to the working state, etc. Table 2 characterizes

state of the counter after each new pulse.

In order to erase information fixed by the counter it is necessary to transfer all triggers entering it into the initial state by supplying a negative pulse at the extinguishing input. Here all triggers, located in working state, will issue negative pulses which can be used as readout pulses or for selection of information from the counter.

As was already mentioned, the quantity of triggers of which the counter consists should correspond to the quantity of digits of a fixed number in the binary number system. Thus, for instance, for storage of number 4 three triggers are necessary, and for storage of number 9, four triggers, etc. Hence it is possible to assume that for fixation and subsequent storage of a large number of pulses there will be needed a very large quantity of triggers, but this is not so. For example, for the storage of number 127 only seven triggers are necessary and for storage of number 4095, twelve triggers, while for storage of number 1,000,000, only twenty triggers are necessary. However, memory units on triggers are nevertheless quite bulky and require continuous consumption of power. Therefore, at present for information storage considerably wider use is enjoyed by other devices, further described.

Let us now consider possibility of using trigger as element of an arithmetic unit: an adder. Diagram of one-digit adder on triggers for in-series addition of numbers in the binary number system is shown in Fig. 18. Anodes of tubes of the two triggers T_1 and T_2 are fed from source E_a through resistors R_1 , R_2 , and R_3 , buses III_1 , III_2 , and III_3 and valves B_3 - B_8 . By magnitude resistors R_1 , R_2 , and R_3 are considerably larger than resistors of trigger tubes by constant current. Therefore, if one of the tubes conducts current, then on the buses to which it is connected, due to the large voltage drop on resistors, the potential will be very small. If, however, to the bus only locked tubes are connected, then on this bus there will appear high positive potential E_a . Voltage at the output of circuit C (sum) and II (transfer) is connected with potentials of the buses: voltage at the output of II is equal to potential III_3 with respect to ground, and at output of C, equal to the higher of potentials III_1 or III_2 . Due to the presence of valves B_1 and B_2 , bus with higher potential is not shunted through the bus with low potential.

Let us agree that the presence at output of high potential signifies 1, and low potential corresponds to 0, and let us follow how addition is carried out in the circuit. Components A and B are introduced into triggers T_1 and T_2 . After addition

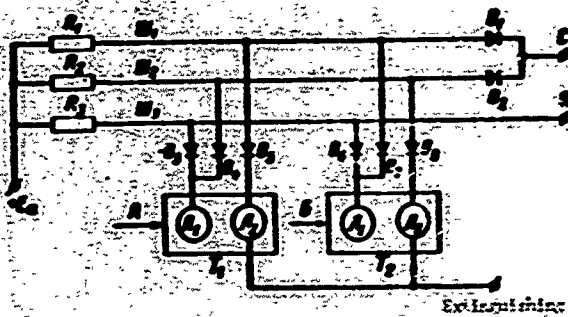

Fig. 18. Diagram of one-digit adder (half-adder) on triggers.

bus \mathbb{I}_3 is grounded through \mathbb{I}_1T_1 and \mathbb{I}_1T_2 . Consequently, on all buses there will be low potential, and on both outlets C and II we will obtain 0. Thus the operation of addition is realized $0 + 0 = 0$. If now number $A = 1$ and $B = 0$, then trigger T_1 will cross to the working state, where bus \mathbb{I}_1 will be grounded through \mathbb{I}_2T_1 and \mathbb{I}_1T_2 , and bus \mathbb{I}_3 will be grounded through \mathbb{I}_1T_2 , and bus \mathbb{I}_2 will be ungrounded, and the high potential from it will arrive at output C. Thus will be realized the operation $1 + 0 = 1$ in the sum and 0 in the transfer.

The circuit will work similarly also when $A = 0$ and $B = 1$, only here the high potential will arrive at output C from bus \mathbb{I}_1 . If $A = 1$ and $B = 1$, then both triggers will be shifted to the working state, bus \mathbb{I}_1 will be grounded through \mathbb{I}_2T_1 , bus \mathbb{I}_2 will be grounded through \mathbb{I}_2T_2 , and bus \mathbb{I}_3 will appear ungrounded, thanks to which high potential from it arrives at output II. Thus the operation of addition $1 + 1 = 0$ in the sum and 1 in the transfer will be realized. However, in such a form the adder permits adding only one-digit numbers; therefore it is called also a half-adder.

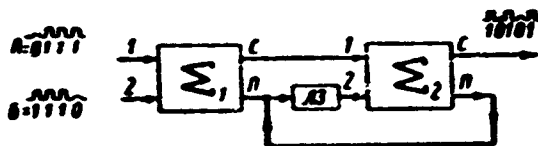

Fig. 19. Circuit for in-series summation of multi-digit numbers.

For addition of numbers with any quantity of digits, it is necessary to construct a circuit which consists of two half-adders Σ_1 and Σ_2 and a delay line $\mathbb{I}3$ delaying pulses passing through it by

one stroke (Fig. 19). Both half-adders are absolutely identical, and each of them is constructed by the diagram in (Fig. 18), i.e., it has two inputs for lead-in of components A and B and two outputs for outlet of the sum and the transfer. Action of the circuit can be followed by example of adding numbers 7 (in binary system 0111) and 1* (in binary system 1110):

$$\begin{array}{r}
 + 7 \rightarrow 0111 \\
 14 \rightarrow 1110 \\
 \hline
 21 \rightarrow 1001
 \end{array}$$

Numbers in the form of a sequence of pulses are sent to corresponding inputs Σ_1 consecutively, digit by digit, starting with the junior digit. Let us consider the state of the circuit at different moments of time.

At the first stroke to input 1 of half-adder Σ_1 proceeds pulse (1); at its input, 2, the pulse is absent (0). Here at output C of first half-adder we obtain pulse which joins input 1 of half-adder Σ_2 , and as a result, the second half-adder issues a pulse at output C. In the second stroke there are pulses on both inputs of the half-adder Σ_1 , and the first half-adder issues pulse on output II. This pulse passes through delay line J3 and arrives at input of half-adder Σ_2 only in the third stroke. Consequently, in the second stroke at both inputs of the second half-adder the pulses are absent and at its output C there also will be no pulse. In the third stroke, to both inputs of half-adder, which arrives at input of half-adder Σ_1 pulses again proceed, issuing a pulse at output II of first half-adder Σ_2 only in the fourth stroke. At the same time, due to a pulse at the second input of half-adder Σ_2 , proceeding from second stroke, at the output C of this half-adder in third stroke pulse is obtained. In fourth stroke the first half-adder, to one of the inputs of which a pulse is sent, issues pulse to output C. This pulse arrives at input 1 of half-adder Σ_2 , but from the third stroke through delay line J3 there will also arrive a pulse at its input 2, as a result of which there will be no pulse on output C, but a pulse will be obtained on output II. This pulse, in the fifth stroke, passing through delay line J3, will appear at input 2 of half-adder Σ_2 and will issue a pulse at its output C.

With the help of the described adder on triggers, it is possible to perform by-digit (in series) addition of numbers with any quantity of digits, where the time spent on addition is equal to quantity of digits of the sum.

Above described circuits can be, of course, built not only on tube triggers, but also on more economic and small-size triggers (transistors) which are the basic elements in circuits of contemporary computer technology.

In Fig. 20 diagram is shown of a trigger with general input, built on two junction transistors. Trigger transfer to a new state occurs upon entry at the general input of the next positive pulse. Here, like in the tube trigger, the unlocking of one transistor creates (due to the connections between their circuits) conditions

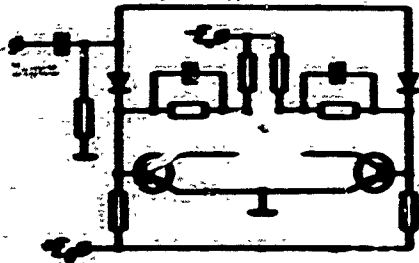

Fig. 20. Trigger circuit on transistors.

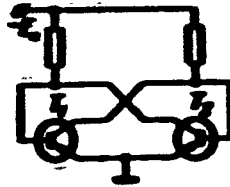

Fig. 21. Trigger circuit with direct connection.

for locking the other, and conversely.

Trigger circuit with direct connection (Fig. 21) is very simple and economic. In this circuit there are only two transistors and two resistors. Principle of its work consists of the following. If one of

the transistors, for instance T_1 , is open, then its stage on its collector is insufficient for opening transistor T_2 . Here voltage on the collector of transistor T_2 is great and sufficient enough to support transistor T_1 in the open state.

For trigger inversion it is necessary to lower the voltage at base of open transistor, or, which is the same thing, at collector of the locked transistor. Control of such trigger requires, as a rule, the application of additional transistors which lowers the basic advantage, the exceptional simplicity of the circuit.

Triggers with direct connections on high-frequency surface barrier transistors have found application in certain computers built in the United States.

Especially great high speed operation distinguishes the triggers on so-called tunnel diodes. Switching time of a trigger on tunnel diodes can reach units and even fractions of a nanosecond. By this the fact is determined that in a number of countries long-term developments are being conducted with cybernetic machines i.e. tunnel diodes which will possess high speed operation on the order of tens of millions of arithmetical operations per second.

8. Information Storage Devices

Memory units utilized for storage of information in machines are characterized by such basic indices as capacity, duration and reliability of information preservation, access time, dimensions, cost, and economy.

In machines they are distinguished two basic forms of "memory:" operational, or internal, and external. First is directly connected with arithmetic unit and is designed for storage of comparatively limited (by volume) information, necessary for the closest calculations. In contemporary machines, capacity of operational memory is limited (in most cases) to several thousand numbers, although sometimes it reaches tens and even hundreds of thousands of numbers.

Basic requirement presented to operational memory devices is a time reduction of the so-called full conversion cycle, i.e., the total time necessary for information readout and recording. This time is units tens of microseconds, although in the test machine samples it is lowered to fractions of a microsecond.

External "memory" is designed for prolonged storage of a large quantity of information, measured by hundred or thousands and millions of numbers. External memory units are often called storage units. They are characterized by considerably smaller speed of recording and selection (readout) of information and they communicate with arithmetic units, as a rule, through operational memory.

Furthermore, during the last few years, especially in specialized machines, more and more often the so-called constant or long-term memory units have been used; these are designed for storage of a certain constant information - constants of programs, coefficients, tables, and reference data. These devices have capacity of from thousands to tens of thousands of numbers, and in certain special cases, millions of numbers, and since in them in work process of information recording is not performed, but only readout, then time of conversion cycle can be fractions of a microsecond.

Let us consider different concrete memory units MU , designed for information storage. Let us here memorize that by expressing number in binary system in the form of ones and zeroes, we can record these numbers by applying two-position technical elements and considering that a charged capacitor, magnetized core, attracted relay, conducting tube, and so forth correspond to a recording of one, while uncharged (or charged in opposite sign) capacitor, nonmagnetized or oppositely magnetized core, released relay, and locked tube correspond to a recording of zero.

Electromechanical and electronic relays. In the first models of computers as MU electromechanical relays were widely applied. However, such MU , with limited capacity (on the order of hundreds of numbers) have rather large dimensions, consume a considerable quantity of electric power, and allow relatively small speeds of recording and readout, since for relay operation a time of not less than several microseconds is required. Besides this, the presence of mechanical contacts sharply worsens the reliability of such an MU . Considerably more reliable and high-speed MU can be built on electronic triggers, contactless elements with an operation time calculated by fractions of a microsecond. However these MU on triggers also have relatively large dimensions, continuously consume electrical current, and

therefore are used only as low-capacity operational MU, calculated for the storage of one or several numbers.

Delay lines. Memory units on delay lines are one of forms of so-called dynamic memory, at which number codes in the form of a series of pulses continuously circulate along the closed circuit (Fig. 22). Delay line is an electrical system,

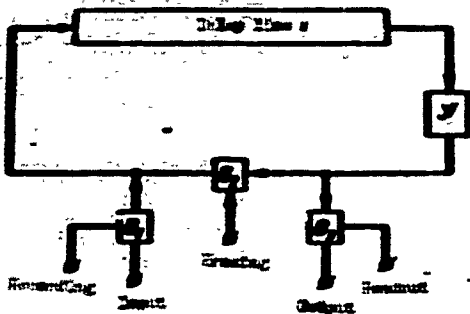

Fig. 22. Block diagram of memory unit on delay line.

along which pulses spread with relatively low speed v . Let us assume that delay line has length l , then propagation time of the pulses along it will be $t = l/v$. If one were to send to delay line pulses with frequency f , then the total amount of pulses, which can simultaneously shift along delay line, will be $n = ft$. Valves B_1 , B_2 , and B_3 play the role of switches, controlled by electrical means. Code pulses of numbers are introduced at the input and, if on

valve B_1 unlocking voltage is sent, they are passed by this valve to delay line, they pass along it, experiencing certain damping, which is compensated by amplifier A , pass through valve B_2 , normally passing pulses, and again enter delay line, etc. Upon necessity to read number circulating along system to the input readout control voltage is sent, which unlocks the normally closed valve B_3 and pulses branch out to system output; however, their circulation along the system continues. For erasing the recording voltage is sent to input erasing, where B_1 is locked, circulation of pulses is ceased, and the MU is ready to record new information.

In the first electronic computers, which were built at the end of the forties, operational MU on mercury delay lines were widely used; these were tubes, filled with mercury, on ends of which piezoelectric crystals, for instance quartz, were placed. To input of the tube pulse modulated oscillations of high-frequency were sent, which caused mechanical oscillations of quartz, transmitted to them by mercury. These oscillations spread along the mercury with a speed near 1,500 m/sec, were transmitted at output of tube to the quartz, which transformed them into electrical oscillations, again proceeding to tube input. In mercury delay line with length of almost a meter it is practically possible to store up to 1,000 pulses. Besides mercury delay lines, in MU there can be used magnetostrictive lines, in which oscillations of ferromagnetic rod during its polarity reversal piezoelectric,

electromagnetic state from inductances and capacitances or resistances MU and capacitances, waveguide and other delay lines are used. MU on delay lines are characterized by great work reliability, but their deficiency is the fact that information readout can only occur at the time of passage of corresponding signals past valve F_3 , which delays selection of information.

At present, MU of similar type on magnetostrictive delay lines are applied only in small machines.

Electron-beam MU. For information storage in machines produced at beginning of the fifties, electron-beam tubes were widely used which resembled kinescopes. There exist several types of memory electron-beam tubes; however, the general principle of their work can be described in the following way.

Information recording occurs on dielectric screen, at any place of which the beam can be directed by corresponding selection of voltages on deflecting plates. By changing the flow rate of electrons and voltage on signal plate located behind the dielectric screen, it is possible, by using phenomenon of secondary electron emission, to impart to any point of the screen a positive or negative electrical charge. By assigning, let us assume, to a positive charge the value 1, and to a negative the value 0, it is possible to record on a number code on the screen.

For information readout it is repeatedly necessary to direct the beam to corresponding points of the screen, which ensures, during supply of corresponding voltage to the signal plate reception of pulses in its circuit. During readout there simultaneously occurs erasure of recording. Therefore, if the recording must be preserved, then readout pulses are again used for restoration of recording on the screen.

The same method is also used for prolonged storage of information: to avoid its erasure due to gradual runoff of charges, in the circuit periodic erasure and recording of information are ensured. Usually in each tube only one digit of the number is stored; therefore, for a recording of n-digit numbers the MU must contain n tubes. On the screen of each tube of the types applied it is possible to record 1,024 or 2,048 units of information, although there have been described tubes with capacity of 10,000 and more binary digits. If the MU consists, let us say, of 20 tubes, then in it simultaneously there can be stored 1,024 or 2,048 twenty-digit numbers.

Writing and readout of information in electron-beam MU occur very fast, in

units of microseconds, and in any sequence. This economically distinguishes electron-beam MJ from delay lines, where it is necessary to await the passage moment of necessary series of pulses past readout valve. Therefore, for several years the memory on electron-beam tubes was the basic form of operational memory in high speed universal digital computers. However, deficiencies of such MJ are their relative cumbersome and stringent requirements for stability of voltage of the power supplies. Therefore, at present, the overwhelming majority of machines have been constructed with operational memory on magnetic cores.

MJ on magnetic cores. For the manufacture of MJ on magnetic cores magnetic materials are used (ferrites) with rectangular hysteresis loop. As can be seen from Fig. 23, in which idealized rectangular hysteresis loop of magnetic material is

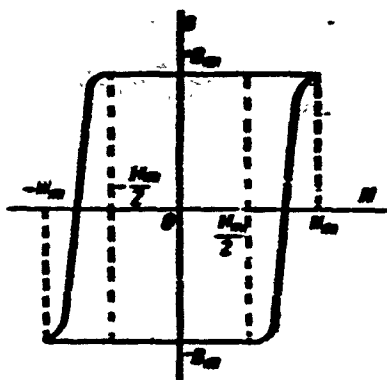

Fig. 23. Idealized hysteresis loop of magnetic material.

represented, with magnitude of field strength $+H_m$, induction in the magnetic material reaches a magnitude of $+B_m$ and, if now we will decrease the field strength to zero or even create a field strength of opposite direction of about $-H_m/2$ and more, induction will preserve its value $+B_m$. Only during approximation of magnitude of field strength to $-H_m$ occurs a reversal of polarity of the material, induction reaches magnitude $-B_m$, and for a new polarity reversal it is necessary to create field

strength of $+H_m$. Thus, material with rectangular hysteresis loop is characterized by the presence of two stable states ($B = +B_m$ and $B = -B_m$), where transferring the material from one stable state to another can be done by creating field strength $+H_m$ or $-H_m$.

From such ferromagnetic material annular cores are prepared which ensure storage of information in the form of binary digits (0 or 1), corresponding to this or that polarity of the magnetic state of cores. On each core there are three windings: two for recording and one for readout of information. Cores are disposed in the form of a system consisting of regular horizontal and vertical rows (Fig. 24), where every horizontal row serves for recording of all digits of one number, and every vertical row serves for recording of one of the digits of all numbers. Thus, the quantity of horizontal rows determines the amount of numbers which can be stored in the MJ and quantity of vertical rows determines maximum quantity of digits in each number.

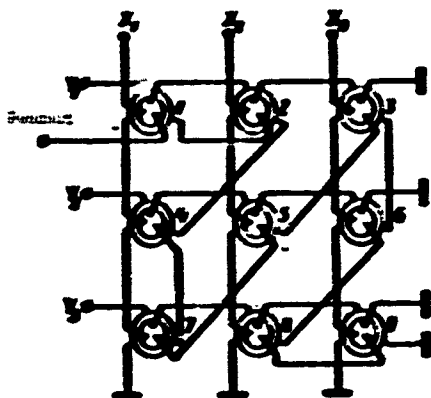

Fig. 24. Diagram of a memory unit on annular magnetic cores.

Windings are joined among themselves, as is shown in Fig. 24, by rows, and all readout windings compose an in-series circuit. Magnitude of current proceeding to inputs X_1, X_2, \dots, X_n and Y_1, Y_2, \dots, Y_n , is equal to $I_m/2$, where I_m is the current conducted necessary for the creation of field strength H_m . Thus, passage of current only along one of the core windings cannot change its magnetic state. If, however, we pass currents along both windings in such a manner that field strengths created by them are added,

this will ensure full polarity reversal of the core. Let us accept as the initial state negative magnetization of all cores, for the creation of which it is necessary to send negative voltage to inputs of all vertical and horizontal rows.

Let us assume that in second horizontal row we want to record the number 101. Let us send positive voltage for this to the input Y_2 and to inputs X_1 - positive (1), X_2 - negative (0) and X_3 - positive (1) voltage. Then in cores 4 and 6 positive intensity will be created, sufficient for their polarity reversal to a state of positive magnetization. Core 5 remains in state of negative magnetization. In such a form the information can be saved for an unlimited time without any expenditure of energy. If we are now required to read the recorded number, then to corresponding horizontal input (in our case to input Y_2) negative voltage is sent and to all vertical inputs X_1, X_2, \dots, X_n negative voltage pulses are sent consecutively, one after another. During supply of pulse to input X_1 there will occur magnetic reversal of core 4, as a consequence of which in the readout winding electromotive force is induced which will create a pulse at readout output. Supplying a pulse to input X_2 will not cause polarity reversal of core 5, since it was negatively magnetized, and at the output we will not obtain a pulse; finally, during supply of a pulse to input X_3 core 6 will be reversed and at the output we will obtain a pulse. For reduction of cost of the device and simplification of its manufacture, the windings on cores can be simply replaced by conductors, threaded through the annular cores, as is shown in Fig. 25.

However, the considered MU circuit possesses essential deficiencies which consist in the fact that first, here by-digit readout takes place, and, consequently,

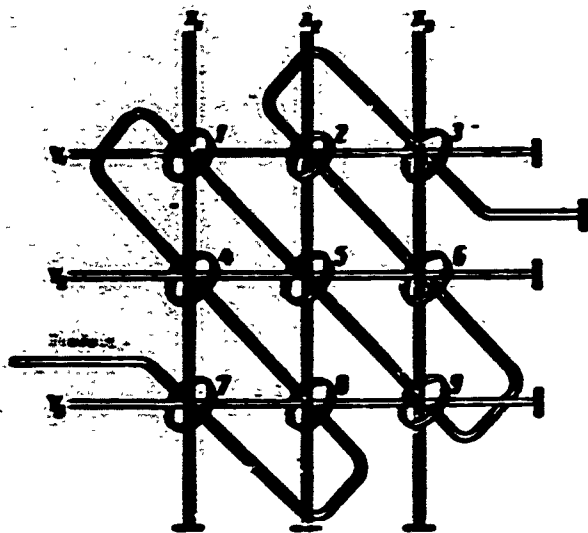

Fig. 25. Memory unit on annular cores with threaded conductors instead of windings.

view of a similar unit, or, as it is often called, a "memory cube" with capacity of 4,096 40-digit numbers is represented in Fig. 26. Unit includes 40 matrices, in

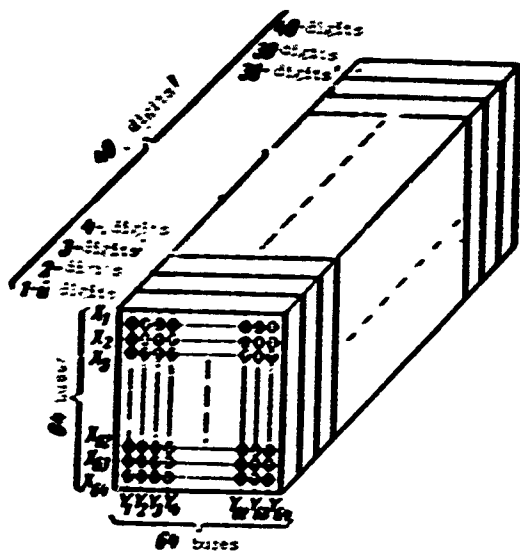

Fig. 26. Schematic view of memory unit block with coincidence of currents.

horizontal matrix row, goes to the second matrix, pierces all cores of its first horizontal row, and further, passing in the same manner through all matrices, is grounded. In the same manner are all remaining horizontal buses X and vertical buses Y assembled.

readout of a multi-digit number requires considerable time and, secondly, with such a circuit it is practically impossible to construct MU of great capacity.

Therefore in an MU with coincidence of currents of great capacitance for each digit of all numbers a separate flat matrix is used, in which quantity of cores is contained which is equal to capacity of MU in numbers. Consequently, an MU designed to store N numbers with n digits a piece should contain n matrices with N cores in each one. These matrices are collected in a general unit. Schematic

each of which there are $64 \times 64 = 4,096$ ferrite cores.

In Fig. 27 diagram is shown of internal matrix connections, where for simplification a matrix with 16 cores in all is shown. For selection of the assigned numerical cell there are eight selecting buses: X_1, X_2, X_3, X_4 , and Y_1, Y_2, Y_3 , and Y_4 . Bus X_1 pierces all cores of the first horizontal row of the matrix, goes to the second matrix, pierces all cores of its first horizontal row of the matrix, goes to the second matrix, pierces all cores of its first

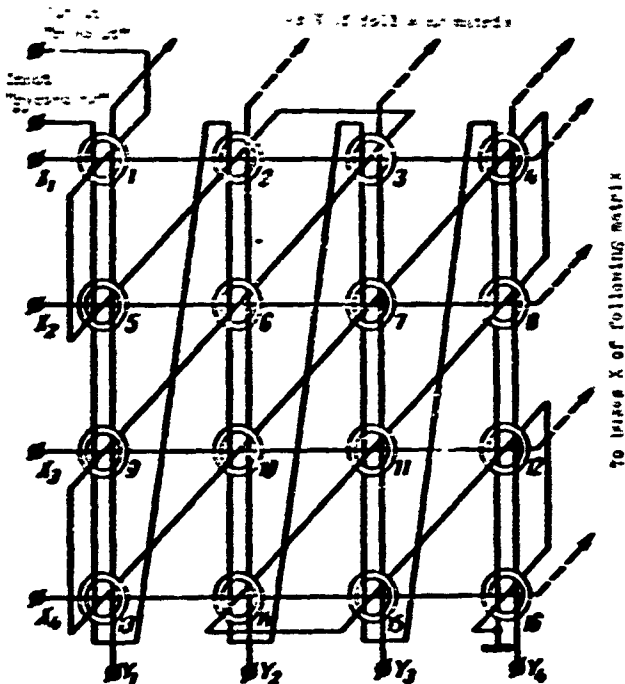

Fig. 27. Diagram of memory unit matrix with coincidence of currents.

Consequently, when sending current pulses coinciding by direction and in time pulses with amplitude of $I_m/2$ by any pair, including one vertical and one horizontal bus, magnetic reversal is insured to this or that state of all cores in all matrices located in the same place. Thus, if one were to send positive pulses with amplitude $I_m/2$ to inputs X_3 and Y_4 , then in all matrices cores 12 would be reversed, i.e., in all digits of numerical cell No. 12 there would be recorded code 1.

Besides the selecting buses, in each matrix there are two more windings - recording and readout, which are separate for each matrix. During

recording of 1 in a given digit, to the input of recording winding no current is sent, and under the influence of currents of the selecting buses, one is recorded in given matrix. If, however, in a given matrix in the chosen core zero must be recorded, then in recording winding negative pulse is sent with amplitude of $I_m/2$, which compensates half of the field strength created by positive pulses in selecting buses. Therefore, the chosen core remains in the initial, i.e., zero, state.

Readout is carried out by means of sending to the corresponding selecting buses negative pulses with amplitude of $I_m/2$, where the chosen cores in all digit matrices are reversed to the zero state and those of them in which one was recorded induce in readout winding readout pulses of one. Thus are ensured simultaneous (parallel) recording and readout of all digits of multi-digit binary numbers.

Along with the described diagram of an MU with coincidence of currents, there have been developed a number of other diagrams MU which ensure higher speed and reliability of work (MU with direct selection, with recording and readout by full currents, and others).

Thanks to great speed of work, reliability, relatively small dimensions, and economy, the MU on magnetic cores are now the most wide-spread type of operational MU in electronic technology. Further ways of improving operational MU on ferromagnetic elements consist of using elements of complicated configurations (so-called transfluxors) multi-apertured ferrite plates, replacing matrices with large number of cores and, finally, thin magnetic films.

The latter are layers of permalloy with thickness on the order of hundreds or thousands of angstrom, obtained by means of precipitating the vapors of metal in a vacuum by electrolytic means. Thanks to very small thickness, and consequently the small volumes of magnetically reversed material, memory elements on thin magnetic films can be magnetically reversed in from units to tens of nanoseconds, which facilitates constructing on their basis a so-called super-operational MU with a time of full conversion cycle on the order of tenth and even hundredths of fractions of a microsecond.

Magnetic tapes, drums and disks. For storage of a large quantity of numbers in external MU, in machines magnetic recording of electrical pulses is widely used by the same principle as sound recording in a tape recorder (Fig. 28). During movement of the tape on it, under the influence of magnetic field created by the recording head, magnetized sections called dipoles are created. On a centimeter of tape length it is possible to record, depending upon recording method, head construction, magnetic characteristics and speed of movement of tape, tens and even hundreds of dipoles with a width of recording channels from 1 to 3 mm. In general, on one roll of tape it is possible to record several tens or hundreds of thousands of multi-digit numbers. For readout the same head can be used as was used for recording: during passage past the head of dipoles recorded on tape, readout pulses are induced in its winding.

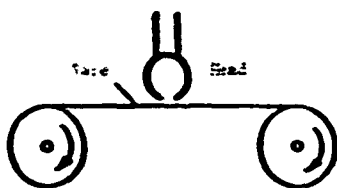

Fig. 28. Diagram of memory unit of magnetic tape.

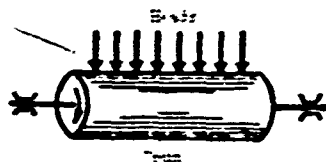

Fig. 29. Memory unit on magnetic drum.

A deficiency of MU on magnetic tape is the relatively prolonged waiting period during selection of the needed number, which is due to the necessity of rewinding the tape. This deficiency is eliminated during information storage on magnetic

drums (Fig. 29). The drum is made of aluminum, on surface of which a ferromagnetic sheet with thickness of 0.01-0.03 mm is applied. Recording and readout heads are located in a row along generatrix of the drum. During work the drum rotates continuously with speed on the order of thousands or tens of thousands of turns per minute. On one drum it is possible to store several thousand or tens of thousands of numbers. Since by means of proper head selection any place of the drum is accessible in one turn, then recording and readout time is near units or

tens of milliseconds, i.e., considerably less than with recording on tape. However, dimensions of MU on a drum are considerably larger, since its internal cavity is not used at all.

For one of the computer models (the United States) there has been developed a MU on 50 magnetic disks, planted on vertical axis, continuously rotating at a speed of 1,200 rpm (Fig. 30). Distance between disks is about 8 mm, which permits bringing

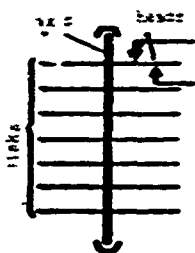

Fig. 30. Memory unit on magnetic disks.

the head to any of 100 concentric channels, located on each of the two sides of the disk. The total capacity of such a device reaches several hundreds of thousands of numbers, the recording and selection of which can be produced in any sequence in a time necessary for bringing the head to desired channel, i.e., on the order of fractions of a second.

The described methods of magnetic information recording possess these essential merits: great capacity, device simplicity, high reliability, possibility of information readout without its erasure, possibility of as long a storage as desired of information without its regeneration and with disconnected feed sources. Deficiencies of magnetic recording include the presence of mechanical movements and consequently the wear-out of parts, the necessity of accurate observance of rotation speeds and accuracy in the magnitude of magnetic gaps, as well as relatively long recording time and readout time. Nevertheless, magnetic recording is at present the basic form of external memory of machines.

9. Arithmetic Units

Arithmetic units of electronic digital computers are designed to execute addition of the numbers expressed in binary system of addition. In § 7 adder was described which was built on triggers. In contemporary machines also used are various arithmetic units built on so-called logical circuits. Let us consider three of the simplest logical circuits: inverter, coincidence, and collecting, by using which it is possible to construct arithmetic units.

In inverter circuit (Fig. 31) great negative potential E_c is sent to the grid of the triode locking the tube. Plate current i_a is equal to zero; voltage on resistor R does not drop and at the output high voltage E_a is obtained. During supply of positive potential to input the tube is unlocked, and since resistor R is much larger than resistance of the tube to direct current, voltage at the output

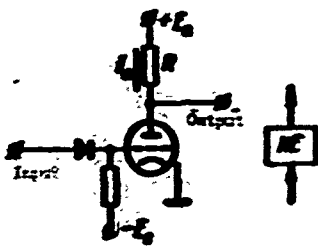

Fig. 31. Inverter circuit.

becomes minute due to the voltage drop on resistor R. Thus, in the absence of a signal at the input there is a signal at the output, and conversely. In block diagrams the inverter will be designated by rectangle with inscription [NO] (HE).

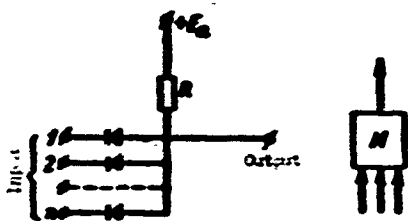

Fig. 32. Coincidence circuit.

Coincidence circuit (Fig. 32) is a multipole with any quantity of inputs and one output. If to all inputs we send a positive signal, then all valves will be locked, current through resistor R will not pass, there will be no voltage drop created on it, and at output voltages E_a will take place. If on at least one of the inputs positive signal is absent, then through corresponding valve and resistor current will pass, due to which voltage at output will become minute. Thus, signal at output of coincidence circuit takes place only when

there are signals at the first, second, and at any input. In block diagrams we will designate this circuit by a rectangle with the inscription [AND] (N).

Collecting circuit (Fig. 33) gives positive signal at the output, when there is a positive signal on at least one of the inputs. In other words, signal at output is obtained when there is a signal at first, second, or at any of the inputs, or at several inputs simultaneously in any combination. In block diagrams such a circuit is designated by rectangle with inscription [OR] (VIV).

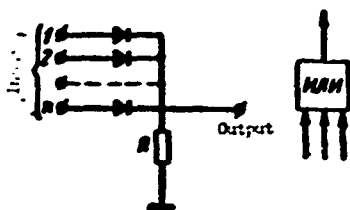

Fig. 33. Collecting circuit.

We have considered one by one the variants of logical diagrams NO, AND, and OR. Any of these three logical functions can be realized with the help of a large quantity of variants of different circuits, gathered on vacuum and semiconductor diodes and transistors, as well as on other elements. In particular, in the last few years there have been developed logical circuits on

ferromagnetic cores which permit constructing a computer containing absolutely no electronic devices. Considering the unlimited period of service of ferromagnetic cores, the possibility of their exploitation during considerable oscillations of temperature, their mechanical strength, small dimensions, and other advantages, one should note that the creation of tubeless machines on ferrite cores is very promising.

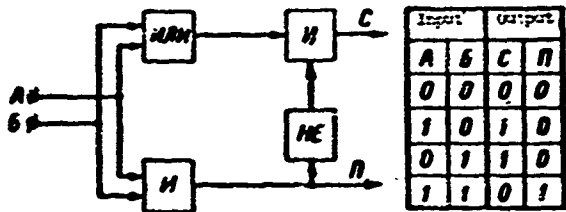

Fig. 34. Diagram and logical table of mono-digit adder (half-adder) on logical elements.

Input			Output
A	B	C	H
0	0	0	0
1	0	1	0
0	1	1	0
1	1	0	1

In Fig. 34 diagram is given of mono-digit adder of in-series action on logical elements. Components in the form of electrical pulses are introduced to inputs A and B of the adder, having two outputs: C is sum and H is transfer to following digit. By remembering functions of logical diagrams NO, AND, and OR, it is

simple to trace the work order of the adder, recorded in the form of a table in Fig. 34.

For in-series addition of multi-digit numbers it is possible to use the diagram in Fig. 19, which we already considered earlier during the use of an adder on triggers. In this case diagram remains absolutely constant, only instead of an adder on triggers we can use in it adders on logical elements. In-series addition of multidigit numbers occurs in as many strokes as there are digits in the components.

To increase work speed of computers it is possible to use more complicated circuits of adders, which ensure simultaneous addition of all digits of components. Here addition of multidigit numbers takes place in one work stroke of the machine. However, quantity of elements in adders and quantity of connecting wires with memory units here are considerably increased, since in the arithmetic unit there should simultaneously be introduced all digits of components.

Simple diagram of such a parallel action adder is represented in Fig. 35. For parallel addition of two n-digit numbers the adder must contain n mono-digits adders $\Sigma_1, \Sigma_2, \dots, \Sigma_n$. To both primary inputs A_i and B_i of each mono-digit

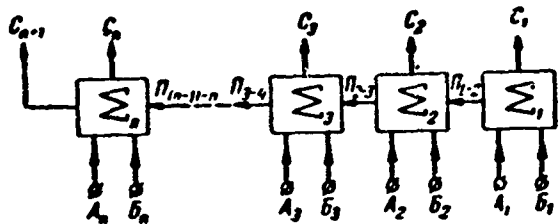

Fig. 35. Multi-digit adder of parallel action.

corresponding digits of components A and B are sent. Every unit Σ_i has two outputs of sum C_i and of transfer H_i ; the latter is connected with third additional input of mono-digit adder Σ_{i+1} . Thus, in the end each mono-digit adder must contain three inputs, A, B, and H, and two outputs C and H where H is output of transfer to following digit.

Diagram and logical table of such a mono-digit binary adder on three inputs, constructed on logical elements, are shown in Fig. 36.

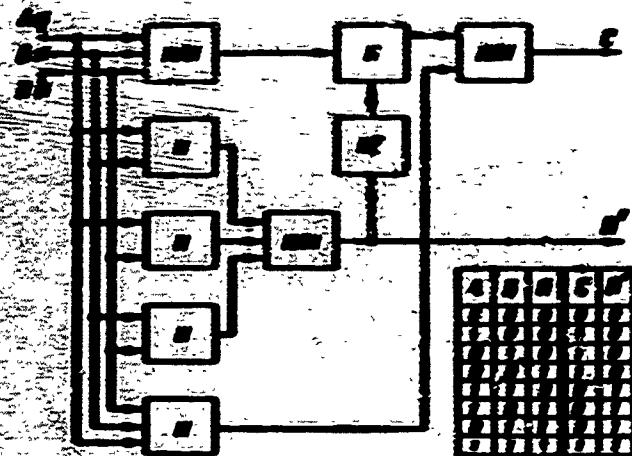

Fig. 36. Diagram and logical table of mono-digit binary adder on three inputs.

10. Devices of Input and Output

Coupling of the machine with the external medium is carried out through special devices for data input and output, through input and output devices. It is necessary to introduce initial data for calculations into machine; i.e., the number and program of work, a description of the actions which machine must perform on the initial data. As will be shown in the following paragraph, the work program is encoded by a system of numbers.

Thus, all that is subjected to lead-in into machine is a series of numbers in a defined order. For this purpose a device with a keyboard is used, similar to keyboard of a typewriter. However, during a blow on the key, figure is not printed on paper, but a hole is pierced on special paper cards, tape or film. Cards perforated thus, or tape or film, are unique memory units which store information, introduced into the machine. For information readout there can be applied either mechanical method of probing the cards or tape with special brushes, closing an electrical circuit in presence of holes, or the improved photoelectric method.

With photoelectric readout (Fig. 37) beam of light from the source, concentrated by optical lens, passes through holes (perforations) in the tape and acts on a photocell, which transforms the package of light into electrical pulses, amplified by an amplifier and then proceeding to memory unit of machine.

Data outlet from machine can also be carried out with the help of punched tape, electromechanical or photoprinting device. Printing the results of calculations takes place in the conventional decimal system, for which in the output device there

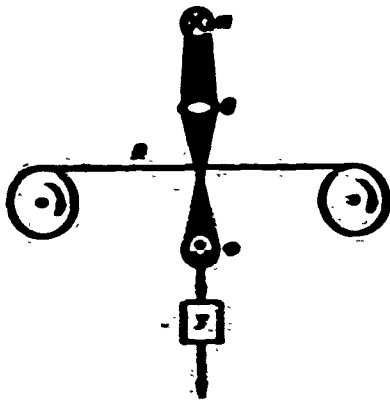

Fig. 37. Photoelectric method of information read-out during data input into machine. S - punched tape; P - source of light; O - optical lens; P - photocell; A - amplifier.

are special decoders, with the help of which conversion of numbers from binary to decimal system occurs.

Here information is given about input and output devices of the machines, solving certain calculating problems, conditions of which are assigned to machine by man, and results of solution are in turn issued by machine in numerical form, convenient for use by man. However, when cybernetic machine solves problems connected with automatic control or adjustment (see block diagram in Fig. 3), to its input most frequently data proceed from without in the form of continuous signals, and the machine should further ensure certain continuous actions on the controlled object.

In this case, data input into machine does not require use of intermediate punchers, but takes place by means of automatic conversion of the continuous information into discrete (digital) form. In turn, during outlet of discrete information from machine, it is necessary, as a rule, to convert it into continuous form. These functions are executed by special information converters, executing the role of connecting links between real objects of systems of automatic control and digital computers.

11. Information Converters

Information converters can be divided into two basic groups: converters of continuous (analog) form of information into digital, which we subsequently will call analog-figure converters, and converters from digital form into analog, which we will call figure-analog converters.

Assignment of converters of the first group (analog-figure) is to obtain numbers at defined moments, which correspond to momentary values of magnitude proceeding to input of converter, continuously changing in time. Here, by step of quantization of the continuous magnitude by level accuracy of conversion is determined, and by step of quantization by time, the tempo of information lead-in in digital computer.

Digital-to-analog converters are designed for the production of analog magnitudes, proportional (taking into account assigned scale) to numbers, proceeding to input of converter from the digital computer. Here the analog values are issued in discrete moments of time, and, consequently, output magnitude has the form of certain step

function with defined step by level.

Analog-to-digital converters are most frequently used in practice for conversion into digital form of such analog quantities as angular shifts, voltage, and time intervals. Let us consider examples of technical realization of similar converters.

As the simplest converter of angular shift into code (shaft-digit) at low rotation speeds, it is possible to use a system with a so-called pulse wheel, schematically represented in Fig. 38. On the shaft, angular shifts of which must be recorded in digital form, there is placed a cogwheel, in the notches of which there enters the end of a lever, held by springs in the neutral position.

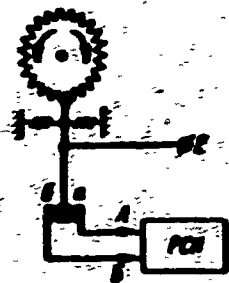

Fig. 38. Shaft-digit converter with pulse wheel.

To lever voltage is brought in from power supply E, and on the other end of the lever there are contacts, which can lock with motionless contact during clockwise rotation of pulse wheel or with contact b during counterclockwise rotation of wheel. Here pulses are sent to in bidirectional pulse counter [PSE] (PC), which upon entry of pulses from input A works on addition, and upon entry of pulses from input B works on subtraction. Thus, on the meter there is fixed (in digital form) resultant shaft turn in a certain direction from the assigned initial position.

At high rotation speeds the geared disk should be replaced by a collector with brushes, and at very great speed one should perform optical yield with the help of rotating opaque disk with cuts. This disk is illuminated by a beam of light, going through the cuts onto a photocell, which issues pulses to recording device.

In improved converters of similar type disks are applied of optical glass with several channels, on which the code is applied in the form of combinations of transparent and opaque sections. This ensures removal of quantities coded in a certain desired code without pulse counting by the current position of code elements on channels opposite readout line. Thus can we obtain not only the usual binary code, but also special codes, ensuring increased noise immunity of the system.

As an example of a converter of time interval into code we will consider diagram depicted in Fig. 39. Converters of similar type find especially wide application in radar and navigational systems.

Stabilized pulse generator [PG] (PW) produces sequence of pulses, where the period of their following determines a selected reading unit of time. These pulses enter pulse counter [PC] (C) through K, state of which ("open" or "locked") is

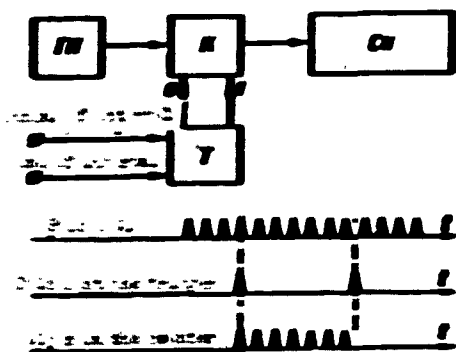

Fig. 39. Block diagram of a converter of a time interval into code.

is determined by state of trigger T, controlled by pulses of beginning and end of converted time interval. Accuracy of such converter depends on the frequency and stability of work of the PG.

During conversion of voltage into code, wide propagation has been obtained by method of so-called time encoding. By this method the conversion is carried out in two stages. In the first stage conversion occurs of input voltage into a time interval proportional to it, while in second stage, conversion of time interval into code takes place.

Block diagram of one of the variants of voltage converters into code with time conversion is shown in Fig. 40. Upper part of diagram including pulse generator PG, key K, pulse counter PC and trigger T, is a repetition of the above considered diagram in Fig. 39.

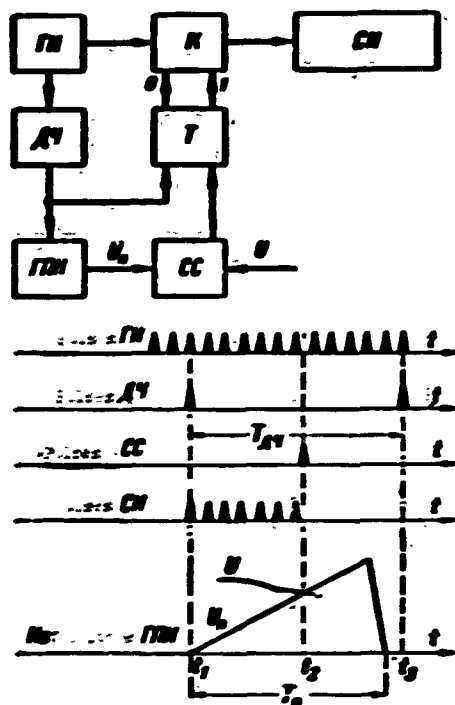

Fig. 40. Block diagram of a converter of voltage into code.

Upper part of diagram including pulse generator PG, key K, pulse counter PC and trigger T, is a repetition of the above considered diagram in Fig. 39.

Fig. 39.

Pulses from the PG also proceed to frequency divider (FD) (FD), whose coefficient of division is determined by assigned step of quantization by time. Pulse from FD is used, first, to start the generator of sawtooth voltage (GSV) (AV) and, second, to control trigger T, which in turn is determined by the state of K.

Thus, at time t_1 of the appearance of a pulse from the FD key K is opened and begins quantity count of pulses in the PC. At the same moment build-up of sawtooth voltage U_{Π} starts, sent to circuit of comparison CC, to other input of which converted voltage U proceeds. At moment t_2 , when U_{Π} reaches magnitude U, comparison circuit CC

issues a pulse overturning trigger T, which leads to cutoff of key K and cessation of the supply of pulses from the PG to the PC. Number of pulses fixed by PC obviously, will be proportional to time interval $t_2 - t_1$ and, correspondingly, to voltage

The indication of the PD is copied in corresponding register or memory unit, after which the counter drops to zero state, and under the influence of following pulse from the PD at moment t_3 begins the following conversion cycle. Naturally, the period of sawtooth oscillations T_{Σ} must be selected in accordance with assigned quantization step of time T_{Δ} in such a manner that condition $T_{\Sigma} \leq T_{\Delta}$ was satisfied.

Devices for conversion of voltage into code are used also for encoding human speech during telephone transmission along communication channels, sound recording and so forth. Here the oscillations perceived by the microphone are sent to an analyzer, which presents them in the form of elementary sound combinations. Their voltages corresponding to these combinations will be converted into codes, which are transmitted along the communication channel. At the receiving end inverse transformation of codes into voltages takes place, from which in synthesizing device the speech report is recreated. Use of such systems permits by several tens of times compressing the necessary frequency band for transmission of telephone conversation and, consequently, increasing considerably the carrying capacity of communication channels.

The most wide-spread type of digital-to-analog converters are converters of code into corresponding current or voltage, where the obtained electrical magnitudes can in turn be worked in the form of angular shift, speed of rotation, and so forth.

As an example of converter of code into voltage we will consider the diagram depicted in Fig. 41. Number code subject to conversion into analog magnitude is

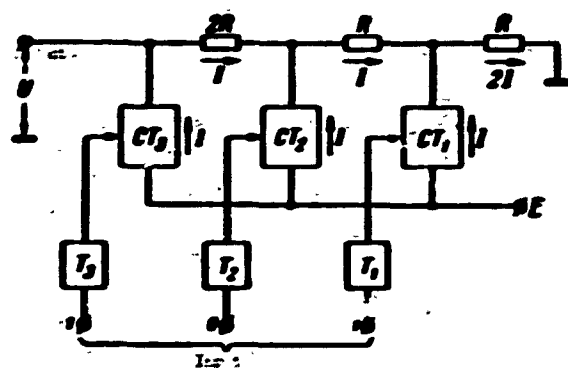

Fig. 41. Diagram of a converter of code into voltage.

fixed by triggers $T_1, T_2, T_3 \dots$. Triggers control the current stabilizers $[ST_1] (CT_1), ST_2, ST_3 \dots$, which are calculated for transmission of current of standard magnitude I . Here only those stabilizers pass current which correspond to triggers located in state 1.

Let us consider an example, corresponding to the diagram in Fig. 41, when to the input the number 101 is sent and is registered by triggers. Here stabilizers ST_1 and ST_3 work, and through standard resistors pass the following currents: through resistor R (on the right) passes current $2I$, and through remaining resistors R and $2R$ passes current I . Thus, the total voltage drop between output clamp and ground (body) composes:

i.e., it will be proportional to coefficient ϵ , the decimal equivalent of code 101.

With the increase of number of digits of counted numbers, correspondingly links of converter are added including stabilizers and standard resistors 43, 88, ...

Converters considered here give only a general representation regarding principles and technology of conversion, which has presently turned into an independent and important branch of cybernetic technology.

12. Types of Electronic Computers and the Prospects of Their Development

Let us now meet with certain concrete types of electronic digital computers, designed and built in our country.

The high-speed electronic computer [BESM] (BSCM) is most widely known; it was created at beginning of the fifties in Institute of Precision Mechanics and Computer Technology of Academy of Sciences of USSR, under leadership of academician S. A. Lebedev. This large universal machine contains almost 5000 electronic tubes; it is located in a hall with an area almost 150 m^2 , and consumes up to 100 kilowatts of electric power. Machine executes up to 10 thousand arithmetical operations per second with numbers containing nine decimal places. Consequently, it can count millions with an accuracy of one, or units with an accuracy of up to one billion.

The BESM is a parallel-action computer. Its arithmetic unit is made on electronic relays (trigger circuits). Operational memory worked on electron-beam tubes, which at beginning of 1957 were replaced by a magnetic memory on ferrite cores. External memory of the machine is made in the form of recording on magnetic tape (120,000 numbers) and on magnetic drum (almost 5 thousand numbers).

Data input into the machine is carried out with speed of almost 20 numbers per second, using punched paper tape with photoelectric readout. Outlet of calculation results is produced with the help of a photoprinting device on film with speed of 200 numbers per second and with considerably lower speed — with the help of a electro mechanical printing device.

Subsequently the machine was modernized and was produced in series under the name BESM-2. In this variant all vacuum diodes were replaced by germanium diodes which decreased dimensions of the machine and permitted lowering considerably the power consumption for its feed.

Along with the development of high speed, but correspondingly more complicated and costlier machines, wide propagation was obtained by cheap small-size machines, accessible to scientific research institutes, design bureaus, and large enterprises. In 1950 the first models of "Ural" machine were produced, designed for serial production.

This machine contains almost 800 tubes, 3000 germanium diodes, and consumes power of 10 kilowatts. For placement the machine requires an area of almost 50 m². It works with speed of 100 operations per second, operating with numbers containing 35 binary digits. Basic elements of the machine are triggers, inverters, and shapers. Memory unit of the machine includes a magnetic drum with 1024 cells and magnetic tape with capacity of up to 40,000 cells. For data input into the machine with speed of 4,500 numbers per minute there is used a preliminarily lighted, perforated standard film, readout from which is performed with the help of germanium photodiodes. Printing of computation results is produced on paper tape with speed of 100 numbers per minute.

Machine "Ural" is the most wide-spread of Soviet computers. However, being a relatively slowly acting machine, it at present has been removed from production. In 1958-1959 there was created a modern form of the machine, "Ural-2," in which operational ZU on ferrite cores was used which permitted increasing work speed from 100 to 5,000 operations per second. Later there was developed and placed into production the machine "Ural-4."

In the Ukraine machine "Kiev" was developed, ensuring fulfillment of 10,000-13,000 operations per second.

Machine "Setun" is interesting; it was developed in Moscow State University and is presently in serial production. This is the first machine working in the ternary number system; it possesses, in the opinion of the authors of development, a number of advantages from point of view of economy of construction of machine devices and simplicity of fulfillment of arithmetical operations. Furthermore, the machine is very reliable, since it is built completely on magnetic elements.

Also produced in series is the machine "Minsk-2," built on semiconductor elements and working with speed of 5-6 thousand operations per second, having a capacity of operational memory of 4096 numbers and consuming about 4 kilowatts.

Also constructed on semiconductor and ferrite elements is the machine "Razdan-2." It works with speed of 5 thousand operations per second, has capacity of operational ZU of 2048 numbers, and consumes power of about 3 kilowatts.

A number of specialized machines have been designed and constructed for control of industrial processes, economic-statistical calculations, automation of train make-up and driving, and for other purposes.

During creation of new machines, designers attempt to decrease their measurements and weights, and attempt to lower consumption of power by introducing new semiconductor diodes and transistors, using of logical circuits of ferrite cores, and increasing volume of memory with simultaneous decrease of dimensions of memory units. Broad prospects in field of creating memory units of great capacity and great high speed operation are being opened in connection with the possibilities of using magnetic films, tunnel diodes, superconductor (cryogenic) instruments, and so forth for this purpose.

Work speeds of serial machines in the near future will reach hundreds of thousands of operations per second. Furthermore, there already now exist unique machines, described in English and American press, work speed of which reaches millions of operations per second (Atlas, STRETCH). In the next few years we can expect the creation of models of machines which will be able to execute tens of millions of operations per second.

In the technology of digital electronic machine building, even greater application has been made of contemporary achievements of the technology of the printed circuit, microminiaturization, film electronics, and solid-state circuits.

After the appearance of the first electronic digital computers, there has passed a little more than fifteen years. In such a short period huge successes have been achieved in their design and production. There are excellent reasons to expect within the recent future new, striking achievements in the swiftly developed technology of electronic machine building.

13. Principles of Work Programming of Machines

Solution of the overwhelming majority of mathematical problems leads to the fulfillment of simple arithmetic operations. To discover, for instance, the roots of the quadratic equation $x^2 + bx + c = 0$ with known values of b and c we, by using formula $x = -\frac{b}{2} \pm \sqrt{\frac{b^2}{4} - c}$ place the numerical values of coefficients b and c and then perform a number of operations, such as division, addition, subtraction, involution, extraction of root, etc. It is possible to show that all these operations in turn can be performed in the form of addition and subtraction. Thus, for instance, in order to multiply number 50 by 10, it is sufficient to add the

number 50 10 times. Consequently, multiplication is reduced to multiple addition. Dividing the number 20 by 5 can be done by means of a number of consecutive subtractions of the divisor from dividend: $1 - 20 - 5 = 15$; $2 - 15 - 5 = 10$; $3 - 10 - 5 = 5$; $4 - 5 - 5 = 0$. After obtaining zero it is necessary to calculate how many times subtraction was performed (in our case, 4 times), and this number is the quotient, i.e., the result of the division. Involution is multiplication of a number by itself, and multiplication, as we already have shown, is reduced to addition, etc.

— Moreover, subtraction itself can be brought to addition during corresponding conversion of number codes. This is especially conveniently done in binary number system, which permits using in arithmetic unit of computers as a universal instrument the adder considered by us earlier.

Possibility of reduction of a rather complicated problem to a defined finite number of steps of simple arithmetical actions permits anyone to solve this problem not even penetrating the essence of problem, not even understanding it, if only another person, a mathematician, composes detailed instructions, a description of the method used in solution of this problem. For instance, we can, absolutely not knowing what a degree is, to find correctly result of $5^3 = 125$, if we know that one should multiply 5 by 5 and once again multiply by 5. Such system of formal rules, allowing purely automatically, not penetrating the essence of the matter, to solve correctly all problems of a certain defined type, is called the algorithm of solution of these problems. This means that by composing algorithm of a given problem, we make accessible to man a purely mechanical solution of this problem, and if we can manage to force (in accordance with composed algorithm) machine to work, then the machine can also correctly solve this problem. Solution process of a problem by algorithm leads to fulfillment of the final chain of elementary arithmetical and logical operations.

Description of sequence of these operations is introduced into the machine in the form of a so-called program, consisting of a series of consecutively executed instructions. Every instruction serves for execution of one arithmetical or logical operation. For an example let us consider the system of three-address instructions, content of which has the form of Table 3.

All operations (addition, subtraction, multiplication, etc.) in machines are also encoded by defined numbers. Let us assume that in our machine there are accepted the following codes of operations: addition 0.1, subtraction 0.2,

Table 3

	Order numbers, taken from memory cells with addresses		Result is dispatched to cell with address
	I	II	III
01	21	27	34

multiplication 0.3, printing of result 07, etc. Then the instruction of Table 3 is decoded in the following way: add the numbers recorded in 21st and 27th memory cells, and record result of addition in 34th memory cell.

Let us give an example of programming of some simple problem. Let us assume that, for instance, it is necessary to calculate the expression

$$(A+B)(C-D).$$

Let us assume that initial data for calculation, i.e., values A, B, C, and D, are placed correspondingly in 22nd, 29th, 36th, and 40th memory cells.

Program of problem solution will have the form represented in Table 4.

As a result of fulfillment of the first instruction (first line of table) in 31st memory cell will be placed sum of A + B. After second instruction, in 34th memory cell there will appear the difference of C - D. After third instruction, in 50th memory cell there will appear result of (A + B)(C - D), which will be printed after fulfillment of fourth instruction.

Table 4

Order number	Address of memory cells		
	I	II	III
01	22	29	31
02	36	40	34
03	31	34	50
07	50	—	—

Program of solution of sufficiently complicated problem can consist of very great quantity of instructions. Considering, however, the possibility of machine fulfillment of tens of thousands of operations per second, it turns out that the machine can even solve complicated problems in very short intervals of time.

Important peculiarities of programming electronic computers are the possibilities of cyclical repetition of separate sections of the program with new initial data, the presence of instructions of conditional transition, at which the machine (depending upon obtained results) either returns to repetition of calculations, or passes to fulfillment of following instruction, or stops, etc. All these special methods of programming permit, with a comparatively short program, executing a great volume of calculations, automatically changing the movement of the calculating process, depending upon obtained intermediate results of calculations, and also permit the machine itself to produce a program of further works, based on the general initial principles of programming.

Composition of programs is a very labor-consuming process, and at present

mathematicians have solved the problem of automatic programming, i.e., compilation of programs of computer work by computers themselves.

CHAPTER III

CYBERNETIC DEVICES AND THEIR USE

14. Controlling Machines

Electron computers, the name indicates, are designed to perform calculations, i.e., operations with numbers. However, at present they have obtained wider and wider use in solution of nonarithmetical problems, in particular for automatic control of industrial processes, military technology, and movement of transport. Possibility of machines fulfilling control functions is determined by possibility of describing these or other processes by mathematical equations, solution of which can be performed by cybernetic machine.

Let us consider, for instance, functions executed by the engineer of an electric locomotive, pulling a train. The operator knows the schedule of movement, the way of the route, train weight, and technical capabilities of electric locomotive. He watches the condition of the route, the signals of the automatic blocking system, considers atmospheric conditions, and actual fulfillment of the schedule, i.e., whether the train is ahead of behind schedule. In accordance with this various information, by weighing it the operator solves the problem of the most expedient control of the electric locomotive. He solves this problem roughly, using his own technical knowledge, industrial experience, and intuition. However, with approximate solution of control problem the latter is often performed in by far not the best method. Really, in the same section under identical conditions a good engineer can economize on electric power, but a less experienced one might overexpend it. But even a good engineer does not always make the best decision, since he often has little time for consideration of this decision while, furthermore, both experience and intuition still do not ensure the fact that the accepted decision is indeed best.

Seemingly problem of selecting the best control conditions of the electric locomotive can be absolutely exactly solved mathematically. If one were to use the equation of train motion and to place in it as coefficients the corresponding data (train weight, profile of the route, speed and others), then by solving this equation we can obtain an exact answer regarding when it is necessary to accelerate or decelerate a movement, with what force to brake, etc.

However the engineer, even if he did possess corresponding mathematical training he could not be occupied by these calculations due to lack of time. The fact is that due to considerations of movement safety the engineer must react quickly to changes of external conditions, even if this speed leads to a certain degree to detriment in accuracy of selecting the best control conditions of the electric locomotive.

The use of an electronic control machine - an automatic engineer - combining the possibility of exact solution of movement control of the train with great high speed operation, ensuring obtaining these exact solutions in a time calculated in seconds, permits it to control the movement of a train better than the engineer does, to lower thus the consumption of electric power and to increase safety of movement.

Analogous principles can be assumed in the basis of automation of any industrial transport process. For realization of this problem necessary first of all is the presence of a sufficiently accurate mathematical description of the process subject to automation. Such mathematical description should be performed, obviously, by engineers of corresponding specialty, familiar in detail with character and peculiarities of the flow of the given process.

Thus, if it is necessary to automate the control process of the locomotive, by an engineer - specialist in so-called traction calculations. To automate control of chemical production, equations which establish numerical ratios characterizing this production, must be recorded by a chemist-technologists, etc.

After corresponding system of equations has been composed describing the given process, program can be developed for electronic control machine, ensuring the solution of these equations and the realization of necessary control actions.

It is important to stress here that a solution by cybernetic means of automatic control problem of any industrial process can give an essential economic and technological effect only when this process is carried out on highly productive,

mechanized equipment and is thoroughly and rationally organized. In a poorly mechanized enterprise with insufficiently productive units, the application of cybernetic technology, as a rule, does not give the proper effect and is economically ineffectual. Before we introduce cybernetic methods of control over industrial processes, it is necessary first of all to perform considerable technological and organizational reconstruction of processes themselves.

During observance of the indicated conditions all advantages of using cybernetic control systems are most fully realized: high control accuracy and reaction speed, ensuring high productivity and economic efficiency. Exclusively important also is possibility of replacing the functions of man as a controlling link of the cybernetic machines in such places, where the location of man is impermissible or undesirable (in conditions of strong radioactive emissions, in harmful chemical productions, during distant space flights, and so forth).

In all cases of using cybernetic machines to control various processes general principles are used of automatic programmed control, illustrated by Fig. 8 and described in § 3. Let us consider more specifically certain concrete cases of the use of electronic computers for purposes of control of different processes.

Control of metal-working machines. One of the forms of control automation of machines without the use of electronic computers is the system of automatic treatment of articles by feeler mechanism. The feeler mechanism is a component controlling the relative motion of preparation and development of a tool during treatment on so-called copying, most frequently duplicating, milling machines. Along the feeler mechanism moves a roller or pin, feeling its profile, controlling in turn the movement of the tool and its preparation. The manufacture of a good feeler mechanism requires high accuracy and is a rather labor-consuming operation.

The use of electronic digital computer permits replacing the feeler mechanism device by such a device, in which the profile of the processed article is assigned by a system of numbers recorded in coded form on perforated paper tape, photographic film, or magnetic tape. In such a form the information about required form of the prepared article enters electronic digital device, executing corresponding calculations and producing instructions for machine control. These instructions, in the form of voltage pulses or in a form converted into continuous values of voltage enter three effectors of the system, ensuring, let us say, shift of the milling cutter by needed magnitudes along three axes of coordinates.

In principle, during automation of machines, the computer can be placed outside the workshop, where it can control simultaneously the work of several machines.

The use of electronic digital control machines increases productivity of labor and lowers the cost of production, due to a reduction in adjustment time of machines, a decrease of expenditures of skilled labor, and an increase of equipment productivity.

Full automation of enterprises with continuous industrial processes. Development of electronic digital technology permits approaching a solution of the question of full automation of complicated industrial objects: conveyers, workshops, whole plants. This problem can most easily be realized in enterprises with continuous (and not piece or intermittent) industrial processes, for instance, in different chemical and oil refining enterprises.

The principle of automatic control possible here is illustrated by diagram in Fig. 42. Let us assume that raw material during processing passes a number of stages of the technological processes $\partial_1, \partial_2, \partial_3$, etc. Control of each stage is

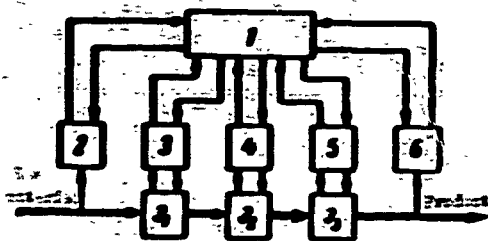

Fig. 42. Block diagram of automatic control of an enterprise with a continuous technological process. 1 - central electronic computer; 2 - analyzer of raw material; 3, 4, 5 - local regulators of stages of the process; 6 - analyzer of finished product; $\partial_1, \partial_2, \partial_3$ - stages of technological process.

performed by one of the local regulators 3, 4, 5, constituting an electronic digital computer, to which program of adjustment of given stage of process is assigned. Local regulators have two communication channels each (direct and reverse) both with the units carrying out stages of the technological process, as well as with central electronic computer. The latter obtains information from local regulators about movement of the process by stages and from analyzers 2 and 6 it obtains data of analysis results of initial raw material and finished product. By comparing results of analysis of finished product with the

technical requirements presented to it and by processing all remaining proceeding information, the central electronic computer, as if executing the role of "dispatcher" of the enterprise, introduces the necessary correctives into work programs of the local regulators. This leads to changes of flow of the stages of the technological process, which ensure obtaining a product of the desired quality.

As the central electronic computer it is expedient to use a machine, which in control process can find the best operating conditions of the enterprise. For this in its memory there must be contained defined appraisals of control movement by one or another program and possibility should be anticipated of automatic transition to another, more profitable work program.

Already there now exist fully automated bakeries, in which cybernetic technology permits (by assigned recipes) automatically making dough from needed components and in required proportions, controlling its baking, and to produce various finished articles. In such plants there exists an automatic system which processes statistical data about the weight of produced articles and automatically correcting the measurement of dough. This has allowed considerably decreasing the overexpenditure of dough and at the same time decreasing deviation in weight of articles from the norm.

In the direction of full automation of enterprises only the first steps have been made. However, it is possible to say with confidence that in the future, application of electronic computers for this purpose will allow considerably increasing the accuracy and operational quality control, and consequently also improving the basic technical and economic indices of production.

Control of electric power stations and power systems. A very bright future belongs to "dispatcher" machines in automated electric power stations, in power systems, and in future single high-voltage network of the Soviet Union, as well as single network of socialist countries, joined by the Council of economic mutual assistance.

For control of all working stages of contemporary electric power stations, especially thermal stations, it is necessary to use a huge number of data units which signal regarding movement of flow of various processes (unloading and preparation of fuel, its supply to boilers, work of the boilers, turbogenerators, transformers, system of energy distribution, and others). Quantity of data units in electric power station reaches several hundreds, where the wires from them are wound up in special instrument cabinets and on boards, designed for observation and adjustment of the processes of production of electric power by the duty staff.

A considerable reduction of quantity of duty staff, and in principle complete automation of control over the work of electric power station can be attained by means of using a cybernetic machine for this purpose. Here the outputs from all

data units are led into the machine, which compares their indications with the assigned values of corresponding parameters, and in case of deviation of these parameters from the norm it ensures issue of correcting influences on controls. If adjustment can be performed by several variants, then the machine (in process of control) calculates and selects the optimum variant.

Exclusively great is the role of cybernetic technology in dispatcher points of large unified power systems. Depending upon power consumption in separate sections of the system, the cybernetic "dispatcher" solves problem of optimum distribution of energy sources and loads, and ensures automatic switch on and stop of units in the electric power stations, switching of transformer substations, high-voltage lines, and so forth.

The use of cybernetic technology in transport. At the beginning of this chapter we considered the idea of a device for automatically driving a locomotive. This idea is assumed on basis of machine developed and built in Soviet Union, called "automatic engineer." It is built completely on magnetic logical elements and semiconductor valves and does not contain one tube, if one were not to consider the kenotrons in power supplies. First sample of the automatic engineer designed for automatically driving electrosections of suburban trains. Subsequently machines were developed for automation of control over electric locomotives and diesel locomotives, as well as subway trains.

Another model of computer, also made on magnetic elements, is designed for automating the process of forming trains on so-called sorting hills of large railroad stations. The rolling stock, subject to sorting, will approach by cars forward to the hill where uncoupling takes place. Having moved through summit of the hill, under action of gravity the railroad cars are rolled downwards along the slanted part of the hill, where, depending upon where the load is going, the railroad car (with the help of pointers) goes to one of the routes of so-called park at the bottom of the hill, where trains for different directions are formed.

So that the railroad car did not strike against railroad cars already standing at bottom of the hill, it must be braked. Braking on nonmechanized hills is carried out by laying special brake shoes under wheels, and on mechanized hills by railroad-car retarders, which are braking tires located on both sides of the rails, pressing the landing of the wheels. Control of railroad-car retarders is performed by the operator from control post. However, since different railroad cars (loaded and

empty, with good or bad bearings) develop different speeds and possess various energy, and also considering that depending upon the congestion of routes in the part at the bottom of the hill, they must pass a different distance, and their braking should be carried out with different intensity, determined by the operator by eye, inaccurately. Therefore some railroad cars stop earlier than necessary, and they must then be rolled manually or by tractor, and others strike against already stopped railroad cars which leads to them being damaged.

Replacing the operator by a electronic computer can give a sharp improvement in the work of a sorting hill. Special radar device, using so-called Toppler effect, continuously measures the speed of railroad car rolled from hill, and thus determines its running properties, caused by weight and quality of bearings. Another electrical device determines the distance to the closest railroad cars standing in the routes at the bottom of the hill. All this information enters the electronic computer, which solves the dynamic problem, at what speed the railroad car should emerge from the retarder so that it stopped at the assigned place, and correspondingly controls the braking in the retarders.

With the use of electronic computers there can be created systems of automatic control over movement of trains in entire dispatcher sections, a device for automatic ticket selling for distant locations including also those with transfers, with automatic elimination of occupied seats, and others.

Abroad there has been developed a model of a superhighway with automatic control of motor vehicle movement along it without drivers, where automatic passing is anticipated of slowly moving machines, and their automatic entrance and departure onto the superhighway.

On superhighways there exist automatic radar speed measuring devices of passing machines, which, in the case of exceeding the speed limit, a camera is automatically turned on, capturing on film the machine number. Thus, at the end of duty, the regulator need only (by automatically manifested film) to extract and to dispatch tickets to the offenders.

The use of cybernetic machines has great prospects for street traffic control. According to reports of foreign press, in 120 crossroads of busiest part of New York there is a device which regulates street traffic considerably better and more exactly than was done by traffic policemen. Into it information is introduced regarding the quantity of machines accumulating in each direction, proceeding

from special meters with photocells or suspended radars, about the expectation time of the first motor vehicle, and finally, about the load of the neighboring crossroads. The use of this system has permitted reducing 360 policemen and decreasing by half an hour the departure time in "peak" hours.

For several years there has been in field testing a cybernetic light signal in Leningrad, developed by colleagues of Leningrad electrical institute of communication in. M. A. Bonch-Brayevich, jointly with [OSUD] (OPV/R) (Division of Street Traffic Regulation) laboratory of Leningrad police department.

This automatic light signal records the accumulation of machines approaching from various directions, and solves the problem, at which moments and for how long it is most profitable to light the green light in a given direction. It passes out of turn fire trucks and ambulances, which have special distinctive radio signal devices. When transport moves for a long time in only one direction, the cybernetic regulator stops this movement to allow passage of pedestrians.

Already at present there are being used, and subsequently more and more widely cybernetic devices will be introduced which are designed for automatic driving (by assigned program) of ships and automatic piloting of aircraft.

Cybernetic technology in military affairs. Possibility of creating self-controlled devices, acting without participation of man, naturally attracts considerable attention of specialists working in field of military technology. Cybernetics was engendered during the years of the Second World War, and was immediately used for solution of a number of problems of a military character. For post-war period, technology of electronic machines has made great successes. It is difficult to enumerate all their possible uses; therefore, we will indicate on the basis of foreign sources only certain military areas, where systems are already used or projected which include electronic computer technology.

First of all, machines are widely used for the production of highly labor-consuming aerodynamic, ballistic (i.e., connected with determination of flight trajectory of missiles and rockets) and other calculations. The great high speed operation of the machine permits calculating exact trajectory of missile in a time shorter than time of the actual flight of the missile.

One of the most wide-spread applications of cybernetic devices in military affairs are systems of automatic fire control of anti-aircraft artillery, joining a radar station, revealing the aircraft at a distance, and an analog computer, which

by the data from radar, calculates the further route of the aircraft and produces instructions for device which guide the weapon and controls automatic firing.

A special role belongs to cybernetic technology in systems of distant detection and interception of high-speed bomber aircraft and ballistic rockets. The American press reported a unique semi-automatic system of antiaircraft defense developed in the United States. In this system information from a large quantity of distant detection radars enters central computer, in the memory of which there are data regarding the presence of means of antiaircraft defense and fighter aviation. Machine solves tactical problem of the best distribution of these means and through computer "subordinated" to it controls automatic opening of antiaircraft zenith artillery fire, the scrambling of fighter aircraft, and launching of guided missiles.

Very promising is the creation (on basis of cybernetic machines) of systems of automatic aircraft flight control. For example, in 1952-1953, in the United States the "Digitac" system was tested in scores of takeoffs; the system was designed for automatic flight control of a bomber and bombing. System permits, by means of radio navigation, determining the position of aircraft, calculating the course of aircraft to an assigned target, and automatically ensuring this course, and by target position data, altitude, flight speed, and meteorological data to determine the point where aircraft must drop its bombs, and automatically control the bombing itself. Electronic computer of system contained 260 tubes and 1,300 germanium diodes. Power drain, including power consumption for cooling, was 1.3 kilowatt. Volume of entire "Digitac" system, including electronic computer, power supplies, receiving and measuring device, cooling and adapter for connection with automatic pilot of the aircraft, composed almost 0.3 m³ at a weight of about 100 kilograms. At present there exist considerably more economic, light weight, and small-size systems of automatic aircraft control.

In connection with rapid growth of intensity of air traffic, and increase of quantity of aircraft located simultaneously in the air in the area both of air bases as well as civil airports, of exceptional value is the automation of dispatcher control over air traffic. For this purpose special control centers have been created.

According to reports of the American press, similar centers are equipped with four specially developed (for this purpose) electronic computers. One of them is designed to process data about the aircraft's following its course, the second will

watch for movement of aircraft in area of the airport, third is a reserve, and fourth serves as an intermediate link to connect the center with antiaircraft defense system.

Cybernetic systems exist which are designed for automatic control over torpedo boats.

Very important role can be played by cybernetic machines in the solution of operation-tactical problems: the collection and treatment of reconnaissance data, encoding and transmission of information about the enemy and about his troops to headquarters of higher subdivisions, drawing the situation on a map, preparation of calculated data for the commanders to make a decision, development of variants of these decisions and others.

Of considerable benefit can be electronic digital computers working away from the front in automation of supply of the army. Their use permits essentially reducing the time for shaping and realizing requests, making more operational the processes of calculation of goods, their storage, transport, and so forth. Machines can ensure both the development of plans in material-technical supply of troops, and automatic control of the realization of these plans.

Finally, important role can be played by cybernetic machines in the improvement of combat training of military specialists as automatic trainers. Wide propagation has been obtained by trainers for the preparation of pilots, astronauts, drivers, tankmen, and other specialists.

15. Informational-Logical Machines

Besides the solution of problems of a calculating character and their application in control systems, cybernetic machines can be used for mechanization of a number of other forms of mental work amenable to formalization, i.e., those which can be carried out in accordance with clear, preset rules. Examples of similar forms of mental labor are calculation, statistics, certain planning problems, translation from one language into another of scientific texts, and so forth.

The informal forms of mental labor are problems of a creative character, for instance, invention, development of new scientific theories, literary and musical creative work, and other problems, in which, although there exists certain conventional rules and norms, the dominating role is played by talent, inspiration, and intuition of the creator. Solution of creative problems is inaccessible to machines, in any case in their contemporary form.

Machines designed for the mechanization of certain processes of the mental labor of man, found in perception, storage, and data processing by a defined logical program, are called informational-logical machines. They can be used for automatic translations of texts from one language to another for treatment of results of scientific investigations and engineering developments, for automation of processes of information search (issue of references), for diagnosis of diseases, for the treatment of different statistical data and fulfillment of planning and economic calculations, for instruction, and for several other purposes. Let us consider certain of the most interesting and prospective types and the application of similar machines.

Automatic translation. First public demonstration of machine translation took place in the [IBM-701] (VBM-701) electronic computer in New York, in January, 1954. In memory unit of machine there were introduced a Russian-English dictionary of 250 words and a program which contained almost 2,400 instructions. For the translation simple text was selected consisting of words "known" by the machine.

In 1955, in [BESM] (B3CM) machine experiments were carried out in translation from English language to Russian. For this in machine memory dictionary was introduced of 952 English and 1,073 Russian words. Among the English words 121 had two different meanings, which was indicated in dictionary with the help of a special code. Regarding the success of these experiments, it is possible to judge by the following extract from an article printed in one of the French magazines in 1956.

"Last summer, during their stay in Russia, members of American delegation were invited to a demonstration of work of an electronic computer, created by Soviet scientists. An experiment in translation from the English language to Russian showed that the Russian machine operated with a dictionary of over 1,000 words and 'composes' phrase with much greater accuracy than does the American machine.

The famous Massachusetts Institute of Technology recently organized a committee consisting of five mathematicians and philologists to detect the secret of the Russian electronic computer."

In fact there were no special "secrets" in the Soviet machine. As is mentioned above, experiments took place in universal machine BESM, not designed especially for translation. Serious successes in this effort were reached thanks to the great work which Soviet mathematicians and linguists performed, developing more perfect methods of translation programming.

Let us try to shortly expound the simplest principles of machine work during automatic translation. Work process of the translator, let us say, during translation from English language to Russian, consists in finding from memory or in the dictionary sufficiently accurate Russian equivalents of English words, in analysis of the English text, and, finally, in correct construction (synthesis) of Russian text. The most simple problem is finding Russian words which correspond to the English. Let us say that we want to translate into Russian the English word book (book). For input of the English text into the machine, it must be encoded in a defined manner, i.e., replaced by numbers, since the machine can only operate with numbers. Let us designate the letter b of Latin alphabet through 06, the letter o through 28, and letter k through 19. Then the English word book will correspond to the number 06282819. For input of English text into machine apparatus is used with typewriter keyboard having with Latin print. During a blow on the keyboard this apparatus pierces a hole in paper tape or punched card corresponding to code of a given letter. Then tape is sent to input device, whence numbers, corresponding to English words, enter machine in the form of electrical pulses.

In machine memory unit the dictionary previously placed there is stored, in which each English and Russian word is also replaced by a number. Search for desired word book consists of comparison by the subtraction method, expressing its number 06282819 with all numbers of the dictionary. Here difference will be obtained equal to zero, only when the desired word is revealed. Considering that machine can perform, let us say, 10,000 subtractions per second, we come to conclusion that even if desired word were at the end of the dictionary, then with a dictionary volume of a thousand words, locating the word would take 0.1 sec.

However it is possible thus to translate only simple words, which are in initial form, and to replace all English words by Russian words in the same order as they were in the English text. For competent translation of real texts it is necessary to select one of the many possible meanings of a multiple-meaning word by means of analysis of words surrounding it, to analyze English text from the point of view of English grammar, and competently to construct a Russian translation in accordance with Russian grammar. All this requires extraordinarily great preparatory work in composition of a sufficiently accomplished program of machine work. Program should be previously introduced into machine along with dictionary, where the large amount of rules and exceptions to them requires very great capacity of memory units,

many times exceeding the capacity necessary for dictionary storage.

At present, work on further improvement of methods of machine translation is being conducted by a large number of scientific collectives both in Soviet Union, as well as abroad. Results of this work will allow, in the future, crossing from experiments to practical application of automatic translation machines. In the first place this problem will be solved for translation of scientific texts, in which, first, the quantity of words is limited, as a rule, to several thousand and, secondly, the construction of sentences considerably more exactly follows existing rules of grammar.

Translation of artistic literature is hampered not only by considerably richer dictionary, but also by the fact that in an artistic literature all kinds of idiomatic expressions are used more often. However, the main difficulty of translating artistic texts consists of the fact that sometimes even formally correct translation turns out to be very far from meaning and spirit from original, because translator of the artistic product must not only know the language well, but should also know the life, culture, and customs of the people from whose language the translation is taken. And such requirement we, of course, cannot present to the machine.

Although translation experiments were carried out in ordinary universal machines, subsequently for translation there will be created specialized machines with considerably more capacious memory units, with special sets of instructions, and with fast-working input and output devices.

Principally solved, but requiring still greater practical development, are the most interesting problems of direct lead-in into the machine of printed text (book, newspaper, magazine), so that in the input device there occurred automatic encoding of letters by numbers. Still more complicated is the problem of direct encoding of sounds of human speech. All of these are problems, which will be solved by joint efforts of mathematicians, linguists, engineers, and physicists.

Reference-bibliographic machines. The continuously increasing flows of scientific information in the form of books, articles, accounts, reports, and patents more and more hamper their use in connection with the difficulties of investigation and familiarization with corresponding materials. If a scientist in the past centuries could become acquainted with practically all of the somewhat sparse literature on an interesting question and this took away from him only an

insignificant part of this working time, then at present such an abundance of literature is published on all questions of science and technology that familiarization with all this literature even in some narrow field of knowledge becomes back-breaking for a man even when he devotes all his operating time to this.

Paradoxical situation appears when the actual abundance of scientific materials on different branches of knowledge becomes an obstacle to the full value and deep mastering of these branches. At the same time the cost of "efforts expended in vain" in scientific research work, according to affirmations of certain authors, is at present more than half of the full cost of these works, since often, in every concrete case, the problem on hand could have been solved by more effective methods or even an already prepared solution could have been had, if beforehand it had been possible to examine all available literature concerning this question.

In connection with the fact that the growth of the number of scientific publications of statistical data occurs not in arithmetical or even in geometric progression, but by power law, then occurs a further rapid "impairment" of the possibilities of access to these all-increasing masses of information.

The only apparent radical means of long-term solution of this question is the creation of data processing computers, capable of accumulation and systematization of large quantities of information and issuing references during the approach from without into the machine in a definite way of an encoded question. The work of similar data processing computer of the future can be graphically shown in the following way.

In memory unit of machine there are recorded (in defined sequence) systematized information on various questions. The number of scientific disciplines in the machine and the width of its scope by material are determined, obviously, by logical possibilities and, in the first place, the volume of its memory. Further, all newly arriving scientific literature on questions which are in the sphere of "competence" of the machine is sent to its input device. Here automatic reading of text, its automatic translation into "native" language of machine, and encoding into digital form takes place. After that the information enters machine and is compared with that already recorded in its memory units. If it turns out that in the newly arrived materials there is no new information as compared to that which is already contained, then this material is not fixed in machine memory. New information is systematized and is recorded in the form of supplements to information already

available in machine.

Appeal to the machine can be carried out by means of querying it by defined code, which corresponds to the discipline of knowledge which interests us or to concrete object of information. Here the machine issues through its outlet organs extensive information in the form of text on a form or in oral form regarding the given question, illustrating it by drawings on television tube screen. For production of information it is not obligatory to be near the data processing computer. Its subscribers can be connected with machine with the help of special or telephone lines. Here for the subscriber there should be a panel of a set of the query code and a device for reproduction of information proceeding from machine. Future machines or complexes of machines of similar type can be called informatoria, telelibraries, or telearchives.

All technical problems connected with the creation of such machines are solved in principle. Devices exist for automatic readout of texts, automatic translation, recording storage, treatment, and reproduction of information. However, the practical realization of the idea of similar informatoria is still far from realization. Contemporary devices of automatic reading and translation are quite imperfect, complicated, and expensive, and have a greater cognitive than practical value. Therefore, at first stage of creation of data processing computers the input of information into them will be, obviously, produced manually by operator.

However, the most important obstacle in the creation of informatoria is the present absence of sufficiently capacious operational memory units with flexible address organization, adjusted for the execution of individual problems placed before them. The fact is that existing units of operational memory have capacitance on the order of tens of thousands or, in the best case, hundreds of thousands of words, whereas data processing computers must have a memory volume measured by at least tens and hundreds of millions of words and more. Ideally the memory capacity of such machines must considerably exceed the memory of man, which is estimated to have a volume of billions and hundreds of billions of words.

Further, so that during information input the machine itself might classify it by content, and during reproduction might detect required objects of information by defined criteria, it is desirable and sometimes vitally necessary to have in the data processing computers memory units with information search not by address, but by content, which are called associative memory units. If the usual address system of

information search in memory can be likened to a search for an addressee by street name, house number, and apartment number, then associative system is similar to search for addressee by his external criteria (sex, height, color of hair, and so forth).

Let us consider construction principles of simplest associative memory units or, more exactly, memory units with search by content and by criteria. Let us assume that in the memory there are m so-called fields, corresponding to m objects of information. Each field contains n words, determining the criteria of these objects. To detect an object of information it is necessary to find the field in which a defined quantity of criteria, introduced in associative memory unit, coincides with the criteria recorded in the field.

Besides reference-informational and bibliographic devices, a similar device can be used for instance, in diagnostic machines, which must issue a diagnosis of a disease by the sum of criteria (symptoms), characterizing state of the organism. Analogously, automatic determinants of chemical compounds, geological rocks, plants, and so forth can work. Such determinants by combination of separate criteria must issue designation of object of information corresponding to these criteria.

Finally, problem of detecting an object of information can be augmented by issuing certain accompanying information. For instance, diagnostic machine, along with diagnosis, can issue recommendation about therapy of the patient.

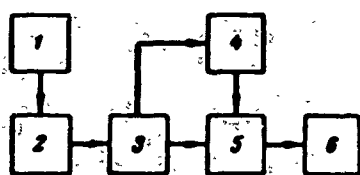

Fig. 43. Block diagram of associative memory unit.
 1 - set of criteria dev
 2 - unit of associative memory; 3 - control device;
 4 - address system; 5 - unit of accompanying information; 6 - outlet device.

One of the variants of block diagram of associative memory unit is shown in Fig. 43. The criteria intended for searching out the object of information are introduced into device of a set of criteria, connected with fields corresponding to these criteria in associative memory unit. Upon coincidence of the criteria recorded in certain field with the assigned, the control device ensures entry into outlet device of the designation of the detected information object. Simultaneously the control device switches on address system of the unit of accompanying information,

which additional information issues to outlet device, characterizing the given object.

Process of search for object of information in described device includes, obviously the following operations.

1. Comparison of introduced criteria with criteria, recorded in the fields of information objects. Here the latter must be kept, for which it is necessary that in associative memory unit there take place so-called noninterrupted information readout.

2. Determining the object of information on the basis of coincidence of introduced criteria with criteria, recorded in field corresponding to this object.

3. Noninterrupted readout and outlet of designation of the manifested object and information accompanying it.

In already developed different variants of associative memory units as the information carrier punched cards, capacitor matrices, magnetic elements (cores, transfluxors and biaxes), and cryogenic elements. Further development of associative memory units of great capacity is one of the most important prerequisites of creating new informational-logical machines of varied assignment.

Control of national economy. The most important problem of cybernetics, as a science of control, is the development of optimum control methods and the construction of control systems. Along with technical and biological control systems, even greater role is played by the use of methods of cybernetics in control processes of planning the national economy of our country.

Basic directions of the use of cybernetics in People's economy are: 1 - the use of cybernetic methods in planning and economic calculations, and 2 - the use of cybernetic technology for collection and treatment of statistical data and other economic information.

By using exact mathematical methods of solving economic problems, it is possible to reach optimum distribution of efforts and means in the different branches of People's economy, and to obtain the maximum economic effect.

One of the ways of solving similar problems is the so-called method of linear programming, bases of which were laid in 1939 by works of Soviet scientist of L. V. Kantorovich. Linear programming permits by mathematical means finding the optimum value of a certain magnitude, which estimates the investigated process, and which linearly depends on a large number of different factors.

Typical example of the use of methods of linear programming are transport problems, connected with the planning of shipments, ensuring minimum transport expenditures, problems on optimum lay-out of material (leather, sheet steel, fabrics), problems on optimum distribution of the load of a machine-tool organization, and

others. Solution of problems from field of linear programming requires the fulfillment of a large quantity of relatively simple but very labor-consuming calculations. Therefore, successful practical realization of these methods is intimately connected with the wide use of contemporary high speed computers.

Great benefits can be brought and already are being brought by introduction of the latest computer technology in the sphere of calculation and statistics, in the organization of material-technical supply, in credit-financial system, in the sphere of trade, in transport control, and so forth.

In conditions of socialist planned economics and centralized control of the national economy exclusively favorable prospects are opened creating a single state network of cybernetic and central computers, connected among themselves by channels ensuring continuous circulation of fluxes of information from enterprises to Council of National Economy and planning bodies and control information from the leading economy organs to the enterprises. Such use of cybernetic theory and technology is a very important factor in the improvement of organization and control of national economy of the country, accelerating the tempo of our movement to Communism.

"Playing" machines. One of the new divisions of mathematics, intimately connected with cybernetics, is the so-called theory of games. Its founder is one of the greatest mathematicians of contemporary time, J. Neumann.

Theory of games was developed on basis of studying such well-known games as chess, checkers, card games, dominos, and others. However it subsequently turned out to be possible to spread its assumption to different situations in national economy and military affairs, which are of a character close to a game.

In point of fact, theory of games constitutes a theory of planning the behavior of sides, aimed at the achievement of an outlined result. Since the theory of games is used to determine optimum form of actions in certain situations, then it can be considered, to a known degree, a branch of linear programming.

Not wishing to go further into details of bases of the theory of games, we will consider the simplest example of possibility of using cybernetic machines for appraisal of a certain situation, for instance for the appraisal of a position during a game of checkers or chess and for selecting one of the reasonable moves corresponding to a given position.

This problem is not simple. For instance, it is impossible to recognize the

best move with which it is necessary to start a chess game, since it is impossible beforehand to foresee the course of a game, depending not only on us, but also on our opponent. However, in any situation it is possible to indicate certain relatively good moves and at the same time a number of obviously bad moves, leading to a loss of pieces or sharp impairment of their arrangement.

For an appraisal of a position in an automatic chess game numerical appraisal of the value of pieces and their location is applied, for instance, by following scale: king - 200, queen - 9, rook - 5, bishop - 3, knight - 3, pawn in normal conditions - 1, the remaining - 0.5, isolated - 0.4, doubled - 0.3, mobility - 0.1 (under mobility we understand quantity of free fields for movement of the strongest pieces). General situation is estimated by the difference of total appraisals of both sides. Good moves are considered to be those which ensure obtaining the greatest positive difference of appraisals in favor of the player. During selection of a move the machine sorts a great number of possible variants of its own moves and answers of the opponent several moves ahead. Practically, the machine now succeeds during chess game in examining all possible variants by only on two or three moves ahead, since with an increase of quantity of moves the quantity of possible variants grows so rapidly that even with its high speed operation the machine, examining all possible variants, including those absolutely absurd from the point of view of the chess player, arrives at the most severe "time trouble."

From the above said it is clear that by "seeing" in all two or three moves ahead, the machine cannot master strategy of the chess game and, consequently, "plays" with mediocrity, at the level of beginning chess player. Therefore, certain information appearing in foreign press of an advertising character is incorrect about the fact that electronic computers even now defeat masters in chess. Certainly, in the future, according to improvement of the methods of programming of the chess game "qualifications" of machines-chess players will be increased.

Considerably more useful is the machine at end of chess game, when number of pieces on board is small, and, thus, quantity of possible variants is sharply lowered. Machine solves rather well the two or three move problems.

Although at present machine chess game does not give serious positive results, intense work on its programming continues and is attracting serious attention of chess players and scientists. The fact is that the methods developed and checked for game of checkers, chess, and other games, can also be used for many practical

purposes, for instance, as the planning of industrial processes and military operations.

Teaching machines. If we consider the teaching process from purely cybernetic point of view, then role of the teacher can be determined as control over process of obtaining knowledge by the one taught. Here, as in any control process, a very important condition of increasing its quality is the presence of feedback from control object (student) to controller (teacher).

In secondary school this feedback takes place by systematic interrogations and checks of home assignments, as a result of which the teacher, although with certain delay, obtains information (by far not exhausting) about mastery of the subject by the students. This enables the teacher to correct educational process, to repeat poorly mastered material, to change the tempo of presentation, to modify method of presentation of various subjects, etc.

In higher educational institutions, where educational process, especially in senior courses, is based primarily on lecture method, systematic feedback is absent and the teacher will recognize the degree of mastery of material only by examination, at the end of the semester or educational year, when some corrections of the course for given flow of students is already impossible. Regardless of the understanding by the teacher of this circumstance, he cannot set systematic feedback from tens, and often from hundreds of students attending the lectures, and in the best case he is limited by episodic conversations with few students, and in the worst case in general, becomes acquainted with them only by examinations.

Meanwhile, successes in development of contemporary cybernetic technology ensure a fundamental possibility of essential improvement of bilateral contact between teacher and student by means of so-called teaching machines. Here the role of teacher not only is not lowered, but increases considerably, while center of gravity of his work is transferred to the deep and tedious work in creation of so-called textbooks and other educational-methodical materials, which would allow the students subsequently to master new material, reinforcement of this material, and a check of this knowledge in process of communication of the students with teaching machines.

Creation of cybernetic teaching machines, which would satisfy all requirements of the pedagogic process, is a very complicated problem, which at the contemporary level of cybernetic technology is yet unsolved, especially if we consider the

necessity of mass manufacture of such machines. For this even greater work is necessary in creation of corresponding logical circuits, input devices, directly from a manuscript or printed text and from voice, identification of images, development of very complicated programs, etc.

However, partial solution of automation problem of teaching can be reached already by means of using relatively simple and cheap teaching machines designed to check the readiness of students for fulfillment of laboratory works, preliminary pre-examination check, self-control of students, and so forth.

As an example let us consider one such machine, developed in the Moscow power institute and called "Ekzamenator." With the help of this machine, the student is assigned a number of questions, accompanied by several enumerated, mutually exclusive answers, from which only one is correct. Student must select correct answer and press the button corresponding to its number. After an answer to all the assigned questions, machine (depending upon relative quantity of correct answers) gives the student his grade.

Information is stored in machine on frames of film, glued in a ring, which contain several tens or even hundreds of separate frames. Part of the frame is projected on small screen of the machine. On this part of frame question is recorded and five answers to this question. In lower part of frame, not projected on screen, there is a band separated into seven white or black parts, which are rectangles. First five rectangles are designed for encoding the number of the correct answer, and other two rectangles are for encoding time, given for consideration of the answer (depending upon degree of complexity of question).

Block diagram of automaton "Ekzamenator" is shown in Fig. 44. Upon pressing starting button [P] (П), unit of random frame selection [BSVK] (БСВК) switches to a certain, changing each time, time tape-driving mechanism. After frame stop its code part is projected on set of photocells of answer number unit [BNO] (БНО) and time delay [BVV] (БВВ).

After considering the answer, student presses one of the numbered buttons, whereupon signal from it proceeds, first, to meter of number of answers [SOO] (СОО), and secondly, to coincidence circuit И, which establishes the correctness of the of the answer, i.e., the conformity of number of the pressed button to the number fixed by unit BNO. If answer is incorrect, then meter of incorrect answers [SNO] (СНО) also works.

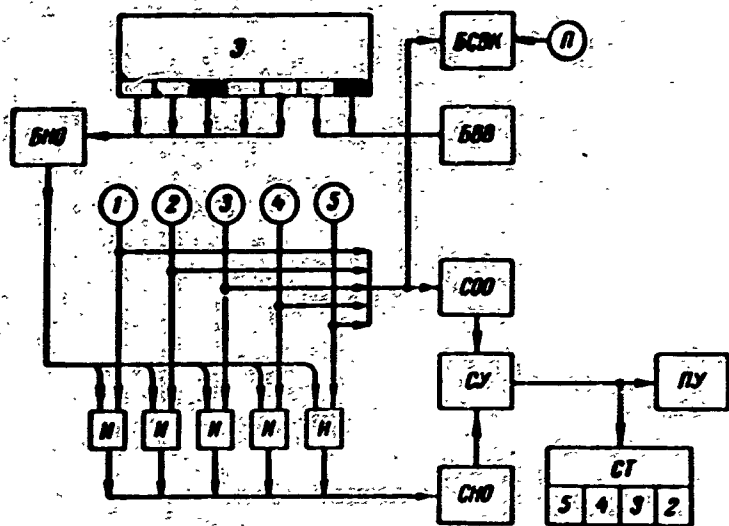

Fig. 44. Block diagram of automaton "Ekzamenator."

After the student presses each button, and also upon expiration of consideration time BSVK is automatically switched on and on the screen a frame is projected with new question and answers. If frame replacement occurs due to a student delay, not having pressed one button, then meter SNO works, just as with an incorrect answer.

Upon completion of answers to assigned series of questions, comparator [SU] (CY) works, which determines the general appraisal, depending upon relationship of the number of incorrect answers and general number of answers. Corresponding appraisal (in digital form) is reproduced on light tableau [ST] (CT) and can be simultaneously placed in student's examination book by perforation device [PU] (IV). All automata, located in class of programmed instruction, can be joined with special panel of the teacher, on the tableau of which grades are repeated which the students received during their interrogation by the machine.

Here we have considered one variant of a relatively simple teaching automaton, performing control functions. During the last few years in higher educational institutions, technical schools, and secondary schools of only our country there have been developed hundreds of variants of teaching devices and machines of different assignment and different degree of complexity.

If one were to additionally equip universal electronic digital computer with special devices of input and with control panels, then it could ensure teaching and control with a sufficiently complicated program of tens and even hundreds of students.

16. Self-Organized Systems

One of the essential deficiencies all the more widely used cybernetic devices at present is the fact that they can work successfully only by relatively rigid

program, previously composed by a man. If, however, during the control of a certain process there appears a previously unforeseen (by the program) situation, then similar cybernetic device cannot further successfully execute control function, and either ceases the process, or allows it to be developed spontaneously, or, finally, continues the control, not considering this newly appearing situation. All these cases can end in the worst case, in an accident, while in the best case the process is developed by means which are far from optimum.

Therefore, in recent years, very considerable attention has been allotted to development of machines, able to perceive and to classify information, coming into them from external medium, and "independently" to develop for themselves programs of information processing, estimating the efficiency of these programs by final results and memorizing the optimum programs for further use in similar situations.

Similar systems have been called self-organized systems. The first, simplest step of self-organization is so-called self-tuning. Self-tuning system, in distinction from ordinary systems, performing adjustment of some process by a strictly defined law, are designed for the realization of more complicated processes of control, requiring automatic self-change of the law of adjustment. Most frequently the self-adjusting systems are designed for automation of search for extreme (maximum or minimum) values of a certain parameter of a controlled process (speed, pressure, temperature, and so forth). Here each time, during change of flow conditions of the process, system again performs search, adjusting to new work conditions.

At a higher level of organization are the taught systems, a characteristic peculiarity of which is presence of a memory, allowing them not only to detect, but also to memorize the most profitable operating conditions corresponding to certain situations. With repeated appearance of the same situation, the taught system, already possessing the "experience" of behavior, can immediately select this profitable operating mode, already "memorized" by it.

In distinction from the self-adjusting systems, self-teaching systems often, at the beginning of their work are absolutely incapable of performing the functions of control. However, there also exist such learning systems, into which have been placed, during their construction, defined rules of behavior, but subsequently, in the work process, it is as if they "complete their education" by investigating controlled objects and processes and by producing perfected methods of control.

Finally, the highest degree of self-organization is characterized by systems

to not only synthesize an improved control program, but also reconstruct (in conformity with conditions and control problems) their own natural structure. It is obvious that in such systems of communication between elements perceiving information, the memory components, and logical and final control elements need not be previously rigidly predetermined, but must be established as a result of attainment to work conditions. Systems of a similar kind are, in full sense of this word, self-organized systems.

Teaching machines. Simple and interesting examples of teaching machines are those relatively primitive devices created at the end of the fifties, often shaped, for interest, in the form of animals, and capable of obtaining and storing certain "vital" experience, as if able to "learn." Such machines include the "mouse in labyrinth," created by one of the founders of the information theory, Shannon; the "tortoise," developed by English physiologist Walter; the "squirrel" of Berkley, the "fox" by Dubrock, and others. Especially popular are "mouse in labyrinth" and "tortoise," often repeated with certain changes by different designers. In particular, in the Institute of automation and telemechanics of the Academy of Sciences of USSR, V. I. Ivanov designed a labyrinth for a mouse, and R. R. Vasil'yev designed a dummy "tortoise." Let us shortly describe the behavior of "mouse" of Shannon and "tortoise" of Walter in their initial designs.

The "mouse" was a cart with drive, which was started in a labyrinth of 25 squares (Fig. 45), formed using detachable partitions. "Mouse" moved gropingly

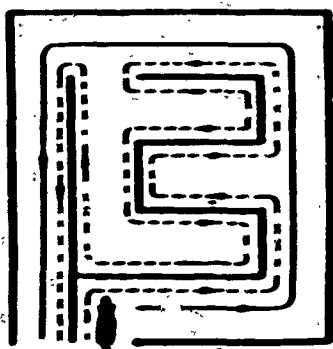

Fig. 45. "Mouse" of Shannon in labyrinth.

along labyrinth, bumping the partitions, and finally, after a prolonged wandering, reached the "bait" in the form of a special contact, placed in last square of the labyrinth. However, being placed in the labyrinth a second time, the "mouse" moved to the "bait" by the shortest route, not going into any dead-ends, i.e., as if he had "learned" to be oriented in the labyrinth.

In reality this problem is solved on the basis of a relatively simple program, introduced into the machine. In the "mouse" were two feeler contacts: front and left. In accordance with the assigned program, the "mouse" continually moved rectilinearly, touching the wall with

his left probe. Upon losing contact it turned to the left and continued to move

thus, until he touches the barricade with his forward contact. Then it turned to the right, moved again, touching the walls with its left contact, etc. Its route was fixed by a special relay memory unit, and if it entered and emerged from some corridor, then this meant that in it there was no "bait," and during the repeated experiment entrance into this corridor was blocked; prohibited.

Described model was created by Shannon as a prototype of the system offered by Wiener concerning accelerated connections of subscribers of an automatic telephone exchange, often speaking amongst themselves.

"Tortoise" of Walter simulates certain behavior traits of a living organism and is a device on little wheels, located in a body, similar in form to an iron. "Tortoise" is equipped with a storage battery, two electric motors (one of which imparts to it forward motion and the second rotation) and two attachments, playing the role of "sensitive elements," receptors. One of the receptors is a photocell, reacting to the light source, and the second is an especially designed contact which locks during encounter of the "tortoise" with an obstacle or during its movement along a steep slope. In front of the "tortoise" there is a control lamp, showing the "on" state and at the same time playing the role of a headlight.

Being in the dark the "tortoise," in search of light source, moved along a complicated trajectory, inspecting in an hour several tens of square meters of surface. Upon encounter with obstacles it by passes large objects and removes from light obstacles its route. It avoids movement along steep slopes and rises, attempting to select horizontal surface for movement. Upon appearance within the limits of "visibility" of the "tortoise" of a light source, it moves to it; however, if this source is too bright then the "blinded" "tortoise" turns and starts a search for another, moderately bright source. Upon encountering a mirror, "tortoise" will recognize itself and move in front of the mirror in a complicated trajectory, first approaching the mirror, and then departing from it.

If one were simultaneously to release several "tortoises," then during a frontal approach they would turn from each other and, missing each other, continue movement. Upon collisions of "tortoises," they react to one another as to the usual obstacles. During the appearance of light source all "tortoises" go to it in a "crowd" pushing one another. If one were to illuminate a "cage" of a "tortoise," then it would enter it, where if its battery needed a charge, the "tortoise" would connect itself to charge current source and remain motionless until termination of

the charge, after which it disconnects itself, turns off the light in the cage, and departs anew in its search.

Later the device was even more complicated to simulate the formation in living organism of the conditioned reflex, where as nonconditional stimulus light was used, perceived by a photocell, and as conditional accompanying stimulus sound was used, perceived by a microphone. The model acted in the following way. It always began to move under the action of light; it moved, consequently, during simultaneous influence of light and sound, and in no way reacted to sound alone. However, if one were to repeat let us say, ten experiments, simultaneously "showing" the "tortoise" light and issuing a sound, then after that the "tortoise" would begin to move under sound alone. But if then during a defined time or a defined quantity of experiments we did not reinforce sound by light, then the formed temporary connection would disappear, and "conditioned reflex" would be eliminated.

Given description of "behavior" of the "tortoise" may cause an assumption of exceptional complexity of its circuit. However, its circuit was very simple, although this simplicity was attained as a result of long and persistent searches for the most expedient solution of the problem.

Models similar to the "tortoise" are of interest for engineers who work in field of automation, both as prototype of machines, adjusting to surrounding situation, as well as for physiologists as a means of studying certain behavior processes of living organisms by methods of simulation. True, the described models are very primitive and are far from reproducing entire complexity of the processes of a living organism. However, subsequently considerably more complicated models were created, more closely reproducing true physiological processes.

Perceptrons. One of the most interesting self-organized systems is self-organized identifying device, developed in Cornell laboratory (the United States) and called the perceptron "Mark I."

In general, perceptrons (from the word perception) are a class of automata, designed for the perception and identification of visual, aural, and other forms. Of essential interest also are perceptron which can identify objects, inaccessible to direct perception of man, such as sources of infrared radiation, radio frequency and ultrasonic oscillations. Application of perceptrons helps the essential simplification of information introduction directly into machines in the form of images, texts, vocal commands, and so forth.

The simplest method of identifying certain images, for instance, letters and figures, can be brought to a simple comparison of them with samples using, let us say, previously prepared patterns. In improved identifying devices different methods are used of image scanning, similar to television, as a result of which coded signals are obtained in a definite way which can be compared with standard codes.

Still more flexible are the taught self-organized systems, which in principle can be taught to identify any situations and objects. As an example of a similar system we will consider perceptron "Mark-I."

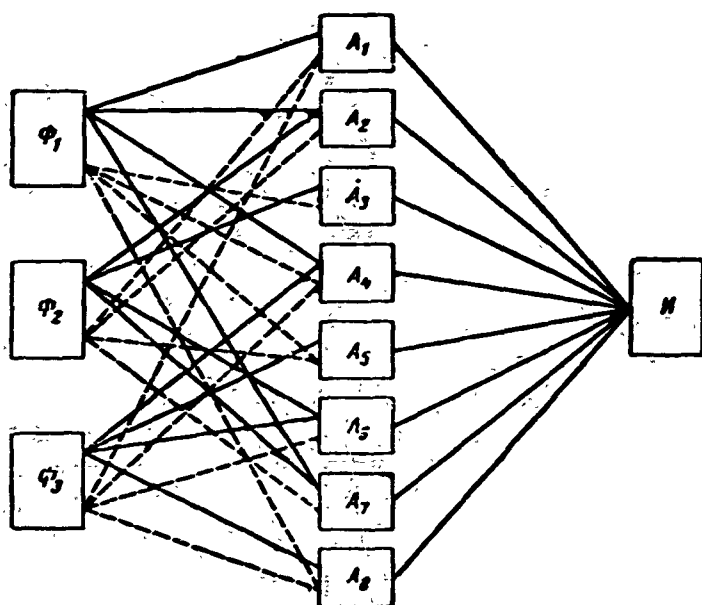

Fig. 46. Diagram explaining working principle of perceptron. Φ - photocell; A - associating cells; N - executive cell.

During illumination of the photocell, at one of its outlets there appears a positive, and on another, a negative signal. These outlets are randomly, in a disorderly manner, joined with associating cells, which work in the following way. If the algebraic sum of signals, proceeding to a certain associating cell, is a positive and exceeds a certain threshold magnitude, then the cell issues a signal to the executive cell. If total value of the signals proceeding to executive cell exceeds the preset threshold value, then it operates in turn.

Since assembly of the perceptron circuit is carried out by random law, then during the showing of a certain image the executive cell can either operate or not operate. The operator involved in the instruction of perceptron randomly changes the characteristic parameters of associating cells until the perceptron begins (in the desired way) to react to a showing to it of a recognized form. Thus is perceptron circuit arranged, calculated for identification of several objects. It has a general field of photocells, a general network of associating cells, and separate (corresponding to each recognized object) executive cells. After a certain

In Fig. 46, in an extremely simplified form, model is shown of perception with three perceiving photocells, eight associating, and one executive cell.

During illumination of the photocell, at one of its outlets there appears a positive, and on another, a negative signal. These outlets are randomly, in a disorderly manner, joined with associating cells, which work in the following way. If the algebraic sum of signals, proceeding to a certain associating cell, is a positive and

period of instruction the perceptron subsequently can "independently" recognize objects about which it was instructed.

17. Bionical Ways of Development of Cybernetic Technology

For the last twenty years the developments of cybernetic technology have reached huge successes in the development, design, and production of cybernetic machines of the most highly varied assignment. If the first models of machines were characterized by high speed operation on the order of tens of simple operations per second and capacity of operational memory on the order of tens of words, then at present has been mastered the mass production of machines working with a speed on the order of tens and hundreds of thousands of operations per second and having a memory capacity on the order of thousands and tens of thousands of words. Unique machines have been created which execute missions of operations per second with an operational memory capacity of hundreds of thousands of words.

However, by many indices cybernetic machines continue to lag far behind the human brain, a number of functions of which they are called upon to simulate. One of the most important deficiencies of these machines, as was already noted above, is the relative rigidity of their program and absolutely insufficient practical results, which have been attained up to now, in field of creating actually useful and workable self-organized devices. Although fulfillment speed by man of formal-logical operations is considerably lower than in the machines, this is essentially compensated in man by his capabilities for the finest analysis and synthesis of phenomena, and, inherent to nervous system, much more effective methods of information processing.

Another important advantage of living organisms is in their incomparably better organs and perception mechanisms of external information. In spite of certain successes reached in the construction of quasivisual and quasiaural perceptrons, the latter still are very far from visual and aural analyzers not only of man but also of living organisms in general.

Further, the undisputable advantage of living organisms as compared to technical cybernetic devices is their considerably higher reliability. If we compare separately taken technical and biological elements intended for data processing (for instance, electron relay or ferrite cores and nerve cells - neurons), then the first possess considerably high reliability. However, multicomponent technical systems turn out to be, as a rule, considerably less reliable than control system of

living organisms, which contain quantity of elements several orders greater. Living organisms are an example of highly-reliable systems, composed from relatively unreliable elements.

This is attained by special structure of nervous networks and considerable possibilities of redundancy, caused by an excess of their organization and the use of excess information encoding.

Finally, biological control systems are many times smaller in dimensions and more economical than technological devices.

All these very thin and perfect mechanisms of perception, storage, and information processing, as well as the remarkable processes of metabolism and energy conversion were produced in living organisms as a result of many millions of years of evolutionary development and natural breeding. The study of these mechanisms for the purpose of using knowledge about them during the development and construction of various technical devices is the content of a new discipline in science - bionics. Thus, bionics can be defined as the science of creating artificial systems, the structure, functions, and characteristics of which are borrowed from biological organisms.

Elementary structural unit of the nervous system of living organisms is nerve cell or neuron. Total amount of neurons in living organisms of the highest animals is determined by a number on the order of 10^9 - 10^{10} . In simplified treatment the neuron is likened often to a two-position relay, which can be in one of two states, actuated or braked. However, it is incorrect to imagine the matter in such a way that it is sufficient to create a cybernetic device with a quantity of relays of the same order as the quantity of neurons in an organism, so that this device might be compared by its capabilities and characteristics with living organisms.

The remarkable specific characteristics of nervous systems and processes in living organisms are determined not only and not so much by the quantity of neurons, as by how much more immeasurably great are possibilities of the neuron as compared to a relay, which is caused by its most complicated and finest organization. This explains the great attention which in bionics is allotted to questions of studying both the mathematical and technical simulation of neurons as prototypes of basic structural elements of cybernetic machines of the future.

In accordance with data of neuro-physiology, the simplest model of a neuron (Fig. 47) must reproduce its following peculiarities:

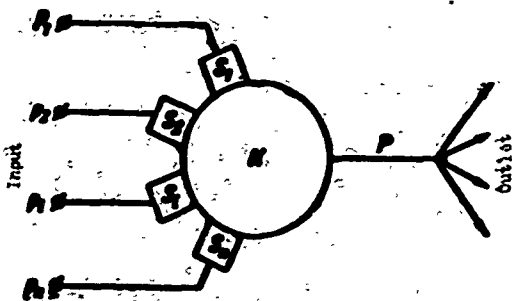

Fig. 47. Schematic model of neuron.

1. Diagram of the model must have a set (n) of entrances, to which there can in different time sequence proceed signals p_1, p_2, \dots, p_n .

2. These signals influence the body of the neuron through synaptic contacts, where the degree of influence of signals on state of the neuron is unequal and is characterized by

so-called weight of entrance or synaptic number S_1, S_2, \dots, S_n .

3. In synaptic contacts delay occurs of the signal for a certain time τ .

4. Influence on neuron body of certain i-th entrance is quantitatively characterized by product $p_i S_i$.

5. Resultant influence on the neuron is determined by the sum of influences from all n entrances (summation in space) and previous history, i.e., preceding influences, considering their damping by exponential law with certain time constant τ (summation in time).

6. Model of neuron must operate (be excited) only when total influence on it exceeds a certain threshold value K.

7. During operation, on branched outlets of the neuron there must appear pulse P with certain standard amplitude and duration.

At present there has been built a huge quantity of various models of neurons on electromechanical relays and tubes, transistors and tunnel diodes, ferrite cores and films, and so forth. All of them, while more or less primitively reproducing the characteristics of natural neurons, which are the most complicated systems, capable of accumulating the greatest volumes of information and fulfilling sufficiently complicated logical functions.

Further problems of bionics are the discovery of mechanisms of exceptionally noise-immune information encoding in living organisms, simulating by technical means the memory and analyzers of living organisms, construction of highly reliable data processing systems on the basis of studying methods by which reliability is attained in living organisms, and so forth.

Literature

Popular Literature

- I. A. Poletayev. Signal, "Soviet radio," 1958.
- L. I. Teplov. Essays on cybernetics, "Moscow worker," 1963.
- N. I. Vershinin, A. L. Vertsayzer, and V. M. Yakovlev. Automatic control, State Power Engineering Publishing House, 1959.
- P. Naslen. Bases of digital computer technology, State Power Engineering Publishing House, 1962.
- L. I. Gutenmakher. Electronic informational-logical machines, Publishing House of Academy of Sciences of USSR, 1962.
- L. P. Krayzmer. Bionics, State Power Engineering Publishing House, 1962.
- E. I. Rovenskiy, A. I. Vemov, and Ye. A. Vemova. Machine and thought, State Publishing House of Political Literature, 1960.
- M. N. Goncharenko. Cybernetics in military affairs, Publishing House of DOSAAF, 1963.
- The possible and impossible in cybernetics, Collection of articles edited by acad. A. Berg and E. Kol'man, Publishing House of Academy of Sciences of USSR, 1963.

For Prepared Readers

- Cybernetics in the service of Communism, Collection of articles under editorial offices of acad. A. I. Berg, State Power Engineering Publishing House, 1961.
- N. Viner. Cybernetics, "Soviet radio," 1958.
- A. G. Ivakhnenko. Technical cybernetics, State Technical Press, Ukrainian SSR, 1959.
- A. A. Fel'dbaum. Computers in automatic systems, Fizmatgiz, 1959.
- A. I. Kitov and N. A. Krinitskiy. Electronic digital computers and programming, Fizmatgiz, 1961.
- L. P. Krayzmer. Storage devices of discrete information, State Power Engineering Publishing House, 1961.
- V. P. Sochivko. Electronic identifying devices, Publishing House "Energy," 1964.
- E. I. Gitis. Electroradioautomation, State Power Engineering Publishing House, 1959.
- L. Brillyuei. Science and the information theory, Fizmatgiz, 1960.
- A. M. Yaglom and I. M. Yaglom. Probability and information, Fizmatgiz, 1960.
- E. A. Yakubaytis. Bases of technical cybernetics, Publishing House of Academy of Sciences of Latvian Soviet Socialist Republic, 1962.