

JOINT REPORT

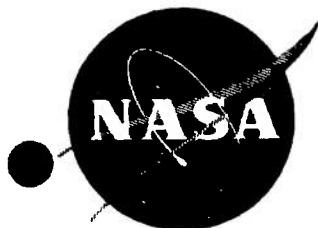

PUBLICATIONS BRANCH

SUBMARINE MEDICAL CENTER

COPY NO.

I

NATIONAL AERONAUTICS AND SPACE ADMINISTRATION
U. S. NAVAL SUBMARINE MEDICAL CENTER

Report Number
488

EFFECT OF ISOLATION IN A CONSTANT ENVIRONMENT ON PERIODICITY OF
PHYSIOLOGICAL FUNCTIONS AND PERFORMANCE

by

Karl E. Schaefer

and

Bruce R. Clegg, Charles R. Carey

J. H. Dougherty, B. B. Weybrew

Bureau of Medicine and Surgery, Navy Department
Research Work Unit MR005.04-0058.03

APPROVED FOR PUBLIC
RELEASE - DISTRIBUTION
UNLIMITED

Released by:

C. L. Waite, CAPT MC USN
COMMANDING OFFICER
U.S. Naval Submarine Medical Center

3 February 1967

PUBLICATIONS BRANCH
SUBMARINE MEDICAL CENTER



The Effect of Isolation in a Constant Environment on
Periodicity of Physiological Functions and Performance Levels

Karl E. Schaefer, Bruce R. Clegg, Charles R. Carey,
James H. Dougherty Jr., and Benjamin B. Weybrew

Bureau of Medicine and Surgery Project

MR005.04-0058

NASA Order No. R 24

This research was supported by the Office of Advanced Research and
Technology National Aeronautics and Space Administration (R 24)

Naval Submarine Medical Center
Naval Submarine Base New London
Groton, Connecticut

The Effect of Isolation in a Constant Environment on
Periodicity of Physiological Functions and Performance Levels

ABSTRACT

Two medical students were isolated for 9 days in a constant environment, in which the temperature was kept at $27^{\circ}\text{C} \pm .1^{\circ}\text{C}$, barometric pressure at $30.560 \pm .004$ inches, humidity at $30\% \pm 5\%$. Respiratory rate, pulse rate, body temperature, skin temperature, basal skin resistance and two channels of EEG were continuously monitored with 8-channel biotelemetry systems during a 4-day control period, nine days of isolation and during a 3-day recovery period. Nine urine functions and 4 saliva functions were studied in samples obtained 4-5 times daily. Psychomotor tests were carried out twice daily and included hand-steadiness, aiming and two-hand coordination.

The two subjects were of different body build and demonstrated distinctly different personality trait configurations. The two subjects reacted to the "constant environment" in an opposite way as indicated in an increased and decreased ketosteroid excretion and corresponding subjective experiences. Daily changes in performance test scores and amplitudes of circadian cycles of physiological functions also reflected differences in personalities.

The subjects shifted during the 8 days and nights of isolation 1.7 hours per day away from the local clock time. Their average total periodicity being 25.8 hours. In contrast to pulse rate, body temperature, and basal skin resistance, respiratory rate did not follow the phase shift of sleep wakefulness cycle and became dissociated in both subjects. Most of the urine functions remained synchronized with the sleep wakefulness cycle for 5 days but broke away during the subsequent 3 days of the isolation period.

In spite of marked differences in individual traits, one being an early riser, the other a late awakener, the two subjects were able to coordinate their meal and sleep times extraordinarily well. The reason being, the late awakener changed during isolation into an early riser. The average length of his circadian cycles of physiological functions were found to be shorter than the length of the sleep-wakefulness cycle resulting in a delay in the phase shifts of the former as compared with the phase shift of the sleep-wakefulness cycle.

Temporary predominance of 6 hour frequencies in respiratory rate and 12 hour frequencies in heart rate, body temperature and basal skin resistance of both subjects during the isolation period and recovery period indicate that the whole spectrum of frequencies was affected by the loss of circadian environmental time givers in these two subjects. The performance levels did not decrease during isolation but showed a tendency to further improvement.

INTRODUCTION

In the projected space flights, astronauts will be confined for several weeks and months in a rather constant environment of the space capsule. The normal 24-hour cycles of the earthly environment, such as light-darkness, temperature, humidity, etc., acting as timegivers to which the nearly 24-hour (circadian) cycles of physiological functions become synchronized, are either absent or greatly modified.

Isolation in a constant environment has been shown to result in "free running" of circadian cycles in a small number of physiological functions in three investigations (1, 26, 21).

Aschoff (1) demonstrated in man a daily shift of about 1-2 hours away from the local clock time in the sleep wakefulness cycle and two functions, body temperature and urinary excretion. It has not been determined whether the free running of cycles of physiological functions has effects on performance levels, which are known to also show diurnal cycles under normal conditions, Kleitman (13).

Furthermore it is not known whether specific phase relationships between the rhythms of organ functions which are characteristic for a healthy organism are maintained or lost during the shift of the sleep wakefulness cycle in a constant environment.

These specific phase relationships of rhythms or organ functions are thought to be responsible for the great diurnal variations in responses to stress (9). Phases of circadian cycles of physiological functions as well as circadian cycles in susceptibility to environmental agents have been mapped for the laboratory mouse, Halberg (9). Approximations of phase maps have also been made for man based on extensive

cross-sectional data published in the literature, Aschoff (2). These data on human circadian cycles were usually obtained under poorly controlled conditions and few rhythms of physiological functions were studied simultaneously on very few subjects. It is quite obvious that the establishment of phase relationship of circadian cycles of physiological functions in man requires the simultaneous study of many different functions in individuals, because of the well known large individual variations in man (31, 5).

Individual traits of subjects living together in a constant environment may produce interactions so as to influence synchronization of cycles. If, for example, a subject who is used to being fully awake and alert early in the morning lives closely with a late awakener adaptive processes in the temporal organization of the latter individual might be dominated by the former.

To answer some of these and other questions, an experiment was designed to monitor a larger number of cycles of physiological functions simultaneously in two subjects during confinement in a constant environment and also to measure performance changes.

It should be emphasized at the outset that the purpose of such a study necessitates a methodological approach wherein the interaction (covariance) between many organ functions within the same person is delineated over time.

Although the accumulation of an enormous amount of simultaneously recorded one-minute-data allows for the identification of principles of temporal organization, it poses obvious practical limitations on the

number of subjects which can be studied.

This is in contrast to the more widely accepted methodological approach in which the average response of a large group of subject is measured. This is usually accomplished by computing the statistics for a limited number of functions measured at larger time intervals. This so called normative as opposed to the intra-personal approach used in this experiment emphasizes average variation and between-person differences over time, while the latter approach emphasizes between-process co-variations within the same person over a given time span. (18, 29)

In short the normative approach emphasizes the average response and predictability of the responses of a sample of subjects to a given set of conditions, while the intra-personal approach is directed more towards the elucidation of the nature of the processes involved.

For the purpose of this paper the position has been taken that the latter information is important to differentiate essential from unessential parameters, particularly in such relatively unexplored research area. The study of a few individuals in depth was therefore the method of choice, which was supported by consideration of possible application of these data to space flight conditions involving few individuals.

Methods:

The personality assessment of the two subjects was accomplished by means of the Minnesota Multiphasic Personality Inventory (MMPI), one of the most thoroughly validated objective diagnostic tests currently in use (10). Briefly, the questionnaire consists of 566 True-False items, which have been empirically grouped into ten major scales, the abbreviated labels

for which are the column headings for the psychograms depicted in Fig. 1.

- - - - -
Fig. 1 about here
- - - - -

These scales are: Hypochondriasis (Hs), exaggerated anxiety concern about one's health; Depression (D), feelings of worthlessness and hopelessness; Hysteria (Hy), incidence of ailments such as headaches which have no physical basis; Psychopathic Deviation (Pd), antisocial and amoral conduct; Masculinity-femininity (Mf), measure of masculine (As opposed to feminine) interests, values and emotional traits; Paranoia (Pa), suspiciousness of others motives based upon irrational beliefs and attitudes; Psychoasthenia (Pt), irrational compulsive acts and obsessive thoughts; Schizophrenia (Sc), withdrawal trends often with hallucinatory and bizarre aspects; Hypomania (Ma), irrational elation and excitement; Social Introversion (Si), avoidance of social contacts. Three additional scales were scored; the L, K, and F scales which measure the tendency to suppress or repress responses suggesting the presence of undesirable traits while admitting responses indicative of desirable characteristics.

A comparison of the T-score (left column in Fig. 1) profiles for subjects G and D in Fig. 1 suggest the following statements:

1. The low L and F scale scores coupled with the relatively high K-score corrections argue that both subjects were highly cooperative, marked the responses carefully and fabricated responses minimally, if at all. In short, these findings argue for the high validity of the obtained subtest scores for both subjects, though perhaps more so for G than for D.
2. The so-called MMPI "neurotic triad" as indicated by trait patterns on the first three scales, Hs, D and Hy indicated different personality syndromes for the two men. For example, G demonstrated more intense anxiety symptoms with exaggerated concern about aches and pains. D, on the other hand, showed rather marked depressive trends as compared to G.
3. D's interests, values and modes of emotional expression tended to be much more masculine than those of subject G as indicated by the profile differences for the Mf subtest scores.
4. On the other hand, G was apparently more suspicious and tended to question others motives, for example reasons for

taking the various measurements, attitudes of experimenters toward subjects and so on. (Note profile differences in Paranoia (Pa) dimension).

5. Similarly, G showed more obsessive-compulsive personality trends allowing for the guarded prediction that he would be more exacting in carrying out instructions necessary for obtaining the data throughout the experiment (Pt score in Fig. 1).

6. Moreover G would be expected to demonstrate more overt excitability and emotionality (Ma score) yet with periodic excursions into a more detached even autistic "world", possibly as a defense mechanism aimed at reduction of the anxiety aroused by the socially (and spatially) restricted environment.

In brief, while neither of the MMPI trait profiles for the two subjects showed pathological deviations differences in personality trait patterns were delineated. These differences will be re-examined later on in the paper in the context of differential physiological response to the absence of environmental periodicities.

Environmental Chamber

A climatized "pressure-altitude chamber" was used to provide a constant environment (Fig. 2). Temperature was regulated by a thermistor-activated pneumatic instrument controlling a heating-cooling glycol system to the chamber, and maintained at $27^{\circ}\text{C} \pm .1^{\circ}$. Barometric pressure was controlled by a pneumatically activated vent-valve. A sensitive differential pressure gauge, referenced to a constant pressure source, provided a set-point signal to the controlling instrument. The chamber pressure was held at 30.560 inches of mercury within a standard deviation of .004 inches. The chamber was continuously ventilated with 100 liters/min provided by a lubricant-free air pump. Humidity was kept at $30\% \pm 5\%$ by a pneumatically controlled chemical drier. Illumination was set at 30-foot

candles during the subjects' day and during the night reduced to about 3-foot candles. Communication through the chamber was by (1) one-way audio out of the chamber, (2) audio code into the chamber, and (3) medical-lock written messages. No measurements of magnetic or electric fields within the chamber were made during the experiment.

Physiological Data Acquisition

The following variables were continuously monitored on each subject: (1) core temperature (rectal), (2) surface temperature (upper arm), (3) basal skin resistance (palm), (4) EEG (occipital), (5) respiration, and (6) EKG. The subjects wore an FM-FM type telemetry vest. The raw data were received at a central location outside the chamber for preliminary reduction and recording. The core and surface temperatures and the basal skin resistances were direct analog signals which passed through low pass filters before being converted to digital form and recorded on standard IBM cards once every minute. These low pass filters (half power frequency, $6(10)^{-3}$ cps.) were necessary to minimize "aliasing" problems during subsequent spectral analyses. EKG and respiratory signals were: (1) converted to minute-rates and recorded digitally on cards once a minute, and (2) monitored graphically every half hour for a duration of two minutes. EEG signals were: (1) graphically monitored, as with EKG signal, every half hour, (2) baseline crossings digitally recorded every minute (indication of prominent EEG frequency) and (3) averaged amplitude digitally recorded every minute (Fig. 3). The enormous amount of one minute data collected during this study made it necessary to

develop computer programs for the correction of artifacts in telementered and punched data and for the analysis of periodicities and phase shifts of circadian cycles. Details on experiences obtained in the use of 8-channel telemetry systems in continuous simultaneous monitoring of the above listed six physiological functions were reported elsewhere (6).

Spectral estimates of the frequencies were based on auto-correlation analysis of three-day overlapping periods. To obtain a more accurate analysis of periodicities in the range of 24 hours and phase relationships, the data were cross-correlated with a synthesized 24-hour sinusoid of known amplitude and phase. This analysis was also based on three-day overlapping periods. A detailed account of these methods has been given elsewhere (7).

Urine samples were collected at three-hour intervals and analyzed for electrolytes, total nitrogen, ammonia, uric acid, and 17-ketosteroids. Moreover, circadian cycles of salivary excretion and of lung functions were investigated and the results of the latter are reported elsewhere (23).

Three psychomotor measures were obtained: (1) handsteadiness was measured by means of a standard Stylus-in-hole instrument, (2) using the same instrument, accuracy of eye-hand coordination was obtained in a sequential (10-trial) aiming series, and (3) two-hand coordination was measured by means of a bi-manual tapping task. All of these measures have been utilized in previous research involving confinement of submariners (30). Practiced to a plateau prior to the confinement, the subjects were instructed to perform the tasks once upon arising and once before retiring for a sleeping period exceeding four hours. Flicker

fusion threshold was determined 3-4 times daily using a Krasno-Ivy flicker photometer.

RESULTS

Subjective Experiences.

Both subjects had worked on the preparation of the experiment for many weeks. They had made for example several sets of the special electrodes which were used during the experiment, and had carried out numerous tests with the telemetry equipment. They were consequently highly motivated to succeed and were most happy to be involved in something they considered important and fascinating, which also had some application in the medical field. The two medical students assumed the role of investigator-subjects in the experiment.

They happened to be opposite types both in constitution and personality characteristics (see Fig. 1 MMPI). One subject (G) was small of stature with rather prominent extrovertive tendencies. He was talkative and tended to be hyperactive in most instances. The other subject (D) was very tall, slow in his movements, quite reserved and he talked very little.

During the experiment they had long conversations and came to know each other quite well. Isolation apparently affected the two subjects in an opposite manner. For example, as the experiment progressed it was observed that G's normally, strongly pronounced, ebullience and sense of humor declines while D's usually reserved personality became more active and outgoing and he felt he was much more humorous than before.

Quite dissimilar sleep wakefulness cycles were also observed for the two subjects. D was not an early morning riser. He reaches ordinarily his maximum alertness in the later morning, while G was an early riser, who is fully awake, when he gets up. During isolation they gained the impression that their diurnal changes in "alertness" and "sleepiness" flattened out to a medium level between being completely refreshed and ready to go and exhausted and welcoming sleep. Subject D found it easier to rise in the morning and was really not "all in" at night when the time came to retire. Both subjects did not feel that their sleep wakefulness cycle had been at all disturbed during the isolation period. They did not wake up at any time during their regular sleeping hours during the isolation. But they both experienced sleep disturbances after their rapid transition to normal clock time in the recovery period. One subject (D) woke up after only three hours sleep at the time he would have awakened during isolation and was not able to go back to sleep.

The subjects tried to maintain a normal level of physical activity but probably did not get quite as much exercise as they usually had. Their appetite decreased during isolation, but they did not lose any weight. They did not have any difficulties coordinating meal times, because they were usually thinking the "same thing."

Average Daily Physiological Values.

Average daily values of respiratory rate and pulse rate and body temperature calculated from recordings obtained at 15-minute intervals throughout the experiment with an Offner 12-channel oscillograph are presented in Table 1. Subject G showed a higher pulse rate and

respiration rate during the whole experimental period. Isolation resulted in a decrease of the respiratory rate in both subjects but did not significantly affect pulse rate or body temperature.

Subject G exhibited a smaller excretion rate of all substances measured although his urinary volume was somewhat higher during the control period (Table 2). Isolation did not cause any significant changes with the exception of the 17-ketosteroid excretion, which decreased in one subject (G) and increased in the other subject (D). It should be noted, that neither calcium excretion nor total nitrogen excretion changed significantly in both subjects during the isolation period which indicates that a normal activity level was maintained.

During the three-day recovery period urinary volume, 17-ketosteroid excretion, calcium, total nitrogen and ammonia excretion declined in subject D who exhibited the stress response during isolation, while uric acid excretion fell markedly in both subjects. Average daily values of salivary constituents did not change during isolation (Table 3).

Sleep Wakefulness Cycles and Cycles of Physiological Functioning.

Figure 4 shows the shift in the sleep wakefulness cycle during isolation in a constant environment. The bars represent total daily activity indicating the times of getting up and going to bed as well as meal times. These times are the same for both subjects. The average daily periodicity calculated from the times of awakening during the eight days of isolation was 25.7 hours. The sleep wakefulness cycle shifted on the average 1.75 hours per day across the local clock time.

After eight days of isolation the subjects got up to 2200 instead of 0800 and were 14 hours off the local clock time. Following the isolation period, the subjects returned within a day to their normal schedule by increasing their activity period to 33.5 hours.

Data on body temperature, pulse rate of both subjects shown in Figs. 5, 6, and 7 are based on records obtained at 15-minute intervals with a 12-channel Offner Oscillograph. The black bars denote the sleeping periods which move during the isolation period across the local clock time. The daily curves of the two functions exhibit circadian periodicities as indicated in their "free running" of the local clock time. The cycles of body temperature, and pulse rate appear to remain synchronized with the sleep wakefulness cycle during the shift, which was confirmed by cross correlations analysis based on continuously recorded minute-by-minute data. (See below)

The position of the minima of body temperature, pulse rate cycles remains associated with the sleeping period throughout the experiment with the exception of the second and third day of recovery. During these two days both subjects showed an inversion of body temperature which increased during sleep. One subject (D) noted that he woke up at 3 A.M. and was wide awake, which never happened to him before at this hour. He had difficulty going back to sleep.

During the control days the subjects began to take naps in the afternoon which show up as troughs in the daily curves of pulse rate and body temperature (Figs. 5, 6, 7). This is more pronounced in Subject D.

From the second to the fifth day of the isolation period the troughs

in the pulse rate curves during the waking hours become increasingly larger resulting in the separation of two maxima, one early after awakening and one later in the day. These changes seem to reflect the occurrence on 12 hour cycles. During the subsequent three days of isolation the troughs disappear leaving one maximum in the early hours after awakening which amounts to a backwards shift of the normal pulse rate maximum.

During the 3-day recovery period following isolation the troughs appear again in the daily pulse rate curves indicating a return of a pronounced 12 hour periodicity. These impressions gained by visual inspection were corroborated by subsequent power spectrum analyses. One-minute data averaged over a 15-minute interval were used for the computer analysis of periodicity and phase shifts. In Figures 8 and 9 such data are plotted for four functions of subject G during the last control day prior to isolation and during the seventh day of isolation. The dotted areas represent the sleeping period. On the control day (Fig. 8) respiratory rate, pulse rate and body temperature show a marked fall in the early part of the sleeping period reaching a minimum during the second part of sleeping time.

The basal skin resistance, known to rise during sleep, shows changes opposite to that of the body temperature and attains the maximum exactly at the time the body temperature reached the minimum. The functions are well synchronized among each other which is not only expressed in the behavior of the circadian cycles during the sleep

period but also in the apparent synchrony of faster cycles of 30 minutes to 1 hour duration throughout the waking hours.

During the seventh day of isolation (Fig. 9) the functions are less synchronized among each other. Respiratory rate reaches a minimum just prior to the beginning of the sleeping period so does the body temperature, the latter increases again and shows from then on the typical pattern of a decrease during sleep.

Circadian cycles of 6 out of 9 measured urinary functions are shown in Fig. 10, in which the data of the two subjects are plotted together. The minima of urinary excretion in general in the sleeping period during the shift of the sleep wakefulness cycle in the isolation period. The amplitudes of the circadian cycles of all the functions are markedly larger in subject D with the exception of the urinary volume. Excretion of the 17-ketosteroids shows a characteristic difference in the two subjects. The oscillations in 17-ketosteroid excretion increase during the isolation period in subject D but decrease in subject G.

Chloride, sodium and potassium, which were excreted in larger amounts in the urine by subject D have correspondingly lower levels in the saliva (Fig. 11). However uric acid behaves differently inasmuch as a higher urinary excretion in Subject D is found to be associated with a higher saliva level. The higher saliva electrolyte levels in Subject G are paralleled by a higher saliva flow rate. All the saliva constituents measured exhibit circadian cycles which shift during the isolation with the sleep wakefulness cycle.

The Psychomotor Data depicted in Fig. 12 also express large individual differences. Subject G had a higher flicker fusion threshold, received higher hand coordination scores, but demonstrates less hand steadiness than Subject D. Moreover the latter performed at an even steady level during the day while the former showed larger diurnal variations (morning-afternoon) of the test scores. Both subjects performed in general better in the afternoon than in the morning, however in the recovery period this sequence was reversed.

Although the subjects had sufficient practice in the psychomotor tests prior to the beginning of the experiment so as to reach a plateau they showed further improvement during the isolation and recovery period, which is clearly expressed in the hand steadiness tests of Subject G (Fig. 12).

Periodicities of Functions

The mean cycle length of the circadian cycles of physiological function was measured by cross correlation of the autocorrelated data from a three-day period with a synthesized 24-hour sinusoid. Using three-day overlapping periods as a basis for the analysis, measurements of the periodicities for the individual days of isolation were obtained. This method represents a good compromise between reduction in accuracy (reducing a recommended ten day analysis period to three days) and the submergence of daily changes and resulting loss of information inherent in the use of longer time intervals for analysis of 24 hour periodicities (7).

Data on the cycle length of the various physiological functions obtained with this method are presented in Table 4 together with the

sleep wakefulness cycle which was determined from the times the subjects were getting up during the different days of the isolation period. Due to the common routine the sleep wakefulness cycle was the same for both subjects.

Subject D had a shorter "physiological day" in respiratory rate, pulse rate and core temperature than Subject G and the cycle length of these three functions in Subject D was also significantly shorter than that of the sleep wakefulness cycle common to both subjects. The cycle length of 5 out of 9 urine functions but none of the 4 saliva functions was found to be shorter in Subject D.

Significant differences from the sleep wakefulness cycle were observed in the cycle length of urine potassium in both subjects and urine sodium, urine calcium, saliva sodium and potassium either in one or the other subject.

Phase Shifts of Circadian Cycles during Isolation

The phase shifts of circadian cycles of various physiological functions were also determined by cross correlation analysis with a 24-hour synthesized sinusoid (7).

Circadian cycles of respiratory rate did not follow the phase shift of the sleep wakefulness cycle and became clearly dissociated in both subjects (Fig. 13). The phase shifts of the cycles of heart rate, core temperature and basal skin resistance remained more or less synchronized with the phase shift of the sleep wakefulness cycle (Fig.13, 14). Basal skin resistance exhibited a temporary backwards shift during the second and third day in both subjects which was associated with a

markedly shorter cycle length during these two days. Subject D who showed a shorter mean cycle length in respiratory rate, pulse rate and core temperature as compared with Subject G also had lesser phase shifts (greater delay) in these three functions either throughout the whole isolation period or during the end of the isolation period. The opposite is true for the phase shift of circadian cycles of urine functions. Here Subject D exhibits in general a closer relationship to the phase shift of the sleep wakefulness cycle than Subject G (Fig. 15). It should be noted that the phase shifts of the circadian cycles of all the urine functions of both subjects were closely correlated with the shift of the sleep wakefulness cycle for 5 days and then became dissociated with the exception of the uric acid cycle. The phase shift in the saliva cycles did not show the same trend in a consistent manner.

Effect of Isolation on the Amplitudes of Circadian Cycles.

The amplitude (difference between daily minimum and maximum) of the circadian cycles of respiratory rate and pulse rate did not change in both subjects during isolation (Table 5). The amplitude of the core temperature cycle decreased only in Subject G, who was found to have larger amplitudes in the circadian cycles of all three functions. He also showed larger diurnal (morning-afternoon) differences in the test scores of the performance tests (Table 5). However, it should be noted that amplitude in the circadian cycles of most urinary functions were smaller in Subject G (Fig. 10).

Power Spectrum Analysis.

Variance spectral amplitudes obtained by power spectral analysis of autocorrelated data from three day over-lapping periods (10) are shown for four functions of Subject D in Figure 16. In the first four to five days of isolation, the amplitude of the 24 hour frequency component decreases while that of the 12 hour frequency component increases and becomes dominant in respiratory rate, pulse rate and basal skin resistance of Subject D. During the last three days of isolation the 24 hour frequency component again becomes more pronounced but decreases again during the recovery period. The core temperature shows a different pattern. The 12 hour frequency component increases more strongly during the last three days of isolation associated with a precipitous decline in the 24 hour frequency component.

The higher frequencies with cycle lengths of 6 hours and 2 hours are pronounced in the spectra of respiratory rate and basic skin resistance but not in those of heart rate and core temperature. The 6 hour frequency seems to play a role in the adjustment to and recovery from isolation for the respiratory rate in Subject D, because of the prominence of this frequency component during the first two days of isolation and the first day of recovery. Figure 17 shows the variance spectral amplitudes of respiratory rate and pulse rate of Subject G. Isolation affects the frequency pattern in a similar way as in Subject D. During the first 5 days of isolation the 12 hour frequency component increases in both functions and becomes more prominent than the 24 hour component

in respiratory rate and reaches a near equal density with the 24 hour frequency component in pulse rate. During the first day of the recovery period, the 12 hour frequency is the dominant frequency in the pulse rate spectrum which corresponds exactly with the frequency pattern of Subject D. (Fig. 16) and with the changes observed in daily pulse rate curves of Fig. 7.

Power spectrum analysis of urinary and saliva cycles did not reveal predominance of 12 hour and 6 hour frequency components at any time during the isolation period probably due to the fact, that samples were not collected at sufficiently frequent time intervals.

DISCUSSION

The term "constant environment" used in this paper denotes an environment in which light intensity, temperature, barometric pressure, humidity and noise level were controlled as closely as possible. For all practical purposes a nearly constant environment was achieved. However no efforts have been made to eliminate subtle environmental influences such as magnetic and electric fields which according to Brown (4) might be responsible for origin and maintenance of cycles. It was not the purpose of this investigation to bear on this question.

Confinement did not have any significant systematic effect in both subjects on performance levels, weight and other basic physiological functions (average daily values) with the exception of the respiratory rate, which decreased.

The respiratory function is distinguished from the other functions measured in as much as it can be influenced consciously by the subject

and is directly connected with the environment. The reduction in sensory impressions during isolation appears to be the most likely cause of the decrease in respiratory rate.

The otherwise negative findings are in line with those recently reported on confinement of 4 subjects for 28 days in a Life Support System Evaluator which did not affect body weight, water and nutrient balance, basic haematological and physiological parameters. (28)

However the two subjects responded to isolation with opposite metabolic stress reactions. One reacted with a decreased and the other with an increased 17 ketosteroid excretion. These physiological reactions corresponded with the subjective experiences, namely, that the normally outward directed type became more withdrawn while the other normally reserved and withdrawn type became more active and outwardly directed. This simply means that a "constant environment" is something different for different subjects depending how his "normal" relationship with his environment is. In other words, there does not seem to be a neutral environment, but rather a person develops a specific relationship to the environment.

Individual Traits

The word type is used here in the sense of individual trait. It is not our purpose to become concerned with human "Types" of a typological system as proposed by Kretschmer (15) nor with the types more recently described by Schreider (25) as "biostatistical categories." As can be seen from this study of circadian cycles, the human organization is much too complex to fit easily into typological systems particular since very little has been done on relations between types and physiological

functions.

With these reservations an analysis of the individual traits of the two subjects is attempted. The two constitutionally different types have been initially characterized in regard to their personalities as outwardly directed and reserved more inwardly directed personalities. Subject G., who has a small body build and who in daily life is geared to quick decisions, actions and faster talk showed also a better sense perception and hand coordination. His daily variations in performance test scores and his circadian cycles of body temperature, respiratory rate and heart rate show an interesting relation in as much as both exhibit larger diurnal oscillations. Subject D., on the other hand, who is very tall and acts slowly and determined and apt to say very little showed a lesser sensory capacity and hand coordination. He is further characterized by a remarkable hand steadiness, a steady level of performance scores during the day and smaller amplitudes of the circadian cycles of respiratory rate, pulse rate and core temperature. One should perhaps expect that the cycles of urinary functions would correspond with this pattern. But here we find just the opposite behavior. The amplitudes of the circadian cycles of most of the urinary functions are markedly larger in Subject D than in Subject G. And as far as the circadian cycles of the salivary constituents is concerned the pattern is again reversed. The lower level of salivary constituents in Subject D and the lesser amplitudes could be considered to be a consequence of the greater urinary excretion.

These findings indicate that the two personality types have a distinct pattern of temporal organization of physiological functions at

different levels. It attests to the complexity of the human organization and underscores a statement made several years ago that the studies of physiological cycles demonstrate how "antiquated the conventional meaning of physiological concepts like homeostasis and steady states have become." (24)

In our findings on two subjects showing a relation between personality type and temporal organization are confirmed on a sizeable number of subjects by similar investigations using an approach in depth, the rhythms of functions might turn out to be the interface of physiological and psychological processes. In considering this possibility one recognizes at once the need for the development of new concepts which are responsive to the dynamics of both physiological and psychological processes. The Minnesota Multiphase Personality Inventory (MMPI) had been routinely used in this laboratory. The results of the test pattern analysis in general confirmed the overt differences in the personality type of the two subjects and established objectively the existence of two distinctly different personality trait configurations. However, personality tests of this kind generally do not provide highly valid predictive relationships to physiological responses. In fact, no significant correlations between MMPI trait patterns and physiological measures were found in a comprehensive study involving 38 submariners (8). This then is the problem; both psychological and physiological attempts to classify men into a few categories (Types) have not been successful in establishing clearly pronounced correlations between physiological

and psychological data of average functional levels. Studies of the temporal organization of individuals will probably provide more sensitive indicators.

Interaction of Subjects during the Isolation Period.

The observations made on the two subjects raise some obvious questions about their interaction during isolation. How is it possible, that two different personality types with so distinctly different temporal organizations could coordinate their activities so well? How could they find an easy agreement on sleeping, waking and meal times, when one is an early riser and the other one a late awakener?

A cursory evaluation of the existing relationship of cycles of some physiological functions and the time of awakening was made by calculating the time interval between beginning rise (from minimum during sleep) of body temperature and pulse rate and beginning fall (from maximum during sleep) of basal skin resistance and moment of awakening. During the control period the average time interval of the three functions in the order listed above were: (1) 75 and 23 min., (2) 56 and 32 min., (3) 35 and 7 min. for subjects G and D. These findings indicate that the phase change from the nightly minimum to the morning rise occurred in both subjects approximately during the last hour of sleep and was indeed earlier in Subject G who claimed to be an early riser. During isolation these phase changes moved towards the earlier hours of sleep in both subjects. The time intervals were: (1) 283 and 354 min., (2) 106 and 177 min., (3) 30 and 20 min. for subjects G and D.

The length of the circadian cycles of body temperature, pulse rate, and basal skin resistance were found to be somewhat shorter than that of the sleep wakefulness cycle in both subjects, but more pronounced in Subject D (Table 4). The phase shifts of the former should therefore be delayed compared with that of the sleep wakefulness cycle (Figs.13 and 14) resulting in the observed movement of the minima of physiological functions to the early hours of sleep. The delay in phase shifts of body temperature and pulse rate cycles is greater in Subject D because the average length of the circadian cycles is shorter in Subject D than in Subject G (Table 4). As a consequence, the normally late awakening Subject D becomes during the isolation period an "Early Riser" in regard to the behavior of the cycles of physiological functions. He even surpasses in this respect Subject G. It is understandable that under these circumstances the two subjects were able to coordinate their activities fairly well. Moreover the observed discrepancies in the phase shifts of the sleep wakefulness cycle and the circadian cycles of organ functions can explain findings indicating that the average depth of sleep as measured by EEG stages decreased during isolation in both subjects. Details on circadian cycles and EEG pattern will be presented in a separate communication. Both subjects had the habit of taking afternoon naps, which were reflected in the records of EEG, basal skin resistance and body temperature. An estimation of the duration of these naps was made based on the evaluation of these records. The average naptime of Subject G and D were: (1) control period - 103 and 117 min.; (2) isolation period - 212 and 121 min.; (3) recovery period - 208 and

110 min. Subject D, who reacted to isolation with an increased ketosteroid excretion and experienced a general stimulation did not change his afternoon sleeping time while the other subject having a decreased ketosteroid excretion and a feeling of letdown lengthened his afternoon naps by a factor of 2.

The information obtained in this rather short isolation experiment with two subjects on cycle variations, that make up the normal background of a person and the influence of cycles on interaction and successful coordination of activities suggests the usefulness of pre-flight isolation tests for astronauts. The Russians did such tests on their cosmonauts Nikolayev and Popovich prior to their first group flight into outer space (27). They reported that both cosmonauts had distinct individual patterns in the sleep wakefulness cycle. Nikolayev initially experienced difficulty in waking up independently, however by the end of the experiment, he began to wake up precisely on schedule, probably due to the phase shift in cycles of body functions.

Synchronization and Desynchronization of Circadian Cycles.

In the previously reported studies on free running rhythms under conditions of a constant environment (1, 26, 21) only few functions were investigated and consequently little information is available on synchronization and transient dissociation of cycles of different organ systems (22).

This report contains the first continuous observation on circadian cycles of respiratory rate, pulse rate and skin resistance under conditions of a constant environment. The cycles of respiratory rate were found to be clearly dissociated from the sleep wakefulness cycle as indicated in

the minimal phase shifts during isolation. Pulse rate and basic skin resistance remain closely synchronized while core temperature shows in both subjects a considerable lag in phase shift. The dissociation of the cycles of respiratory rate is in contrast to the simultaneously studied cycles of other lung functions such as vital capacity inspiratory and expiratory capacity, maximal inspiratory and expiratory flow rates, all of which remain synchronized with the sleep wakefulness cycle shift (23).

The rhythm of urine potassium excretion which is known to show a persistence of the intrinsic 24 hour pattern under different experimental time schedules (16) also exhibits in this experiment in both subjects, a cycle length close to 24 hours, which is significantly different from the 25.75 hour rhythm of total daily periodicity. The trend of most of the urine rhythms to dissociate from the shift of sleep wakefulness cycle after 5 days of isolation is difficult to interpret without having additional data from experiments with longer isolation periods. The uric acid rhythm of the urine stands out as being most closely synchronized with the sleep wakefulness cycle.

Role of Cycles with Higher Frequencies.

In the previous studies of free running rhythm in man cycles of higher frequencies (12 hours and 6 hours) have not been investigated. Power spectrum analysis of data obtained at one minute intervals showed in all cases, that the 12 hour frequency component becomes, during the isolation period, temporarily a predominant frequency. This is clearly expressed in the heart rate. It could be conceivable that the 12 hour

rhythms is artificially introduced by the habit of the subjects to take naps--in the afternoon. But they took these naps throughout the whole experimental period during which the 12 hour frequency component first increased in intensity during the first 5 days of isolation then decreased during the subsequent 3 days of isolation and again increased during the first day of recovery.

The observed changes in the 12 hour frequency component must, therefore, be independent of the habit of taking naps. The appearance of dominant 12 hour frequency components in the beginning of the isolation period and in the beginning of the recovery seems to indicate that they play a role in the adjustment of the temporal organization to the loss of normally present environmental time givers, as well as in the re-establishment of synchronization with the environmental time givers on return from free running conditions.

Menzel, Blume and v. Schroeder (20) also reported the occurrence of 12 hour cycles in body temperature and urinary excretion during the recovery from a hepatitis based on a phase and amplitude diagram analysis(3). These findings (Fig. 9-a-f, pp.256/257) showing a temporary predominance of 12 hour cycles are quite similar to those demonstrated in our experiment in two healthy subjects during the adjusting to isolation. The clearly defined changes in 24 hour periodicities found under our experimental conditions might therefore serve as a model for periodicity changes observed in the clinic.

Change in the strength of 6 hour frequencies pronounced in respiratory rate of both subjects suggest that the whole spectrum of frequencies

is affected when the environmental circadian time givers are excluded. The temporary predominance of faster cycles (5-7 hour frequency band) in the periodicity spectrum is reminiscent of a persistent predominance of 6-9 hour cycles in urinary excretion which have been described by Menzel (19) as a form of circadian pathology in renal disease. In this case the pathological process seems to have a direct effect on the circadian rhythm which breaks down into faster cyclic components. The latter might represent the basic components from which the 25 hour circadian cycles are synchronized requiring a mature healthy organ. This notion is supported by investigations of the development of sleep wakefulness cycles in infants, which demonstrated that monophasic (circadian) rhythms develop from polyphasic (faster 3-6 hour rhythms) during early infancy, Kleitman and Engelmann (14, Hellbrügge (11). Polyphasic rhythms of water excretion were also observed by Lobban (17) in a small group of human subjects in response to exposure to continuous daylight during a journey in the Arctic Summer. While the water excretion rhythms became completely disorganized when the subjects were exposed to the continuous daylight, the urine potassium excretion retained its normal well defined 24 hour rhythm demonstrating its independence of environmental influences.

Cycles with higher frequencies may appear without dominating or replacing the circadian cycles. Hildebrandt (12) found 12, 8, and 6 hour cycles superimposed on the 24 hour cycle of pulse rate, respiratory rate and vital capacity in two healthy subjects during 6 days of bedrest. He concluded that these higher frequencies are "reactive periodicities"

occurring in response to the environmental time givers since they show the largest amplitudes in the morning after awakening and flatten out during the subsequent day and night hours.

Although the different organ systems show different "reaction periodicities", they all appear to be sub-multiples of the 24-hour spontaneous periodicity. This suggests an existing coordination of "reactive and spontaneous periodicities" within the framework of the total temporal organization which could account for amplification or damping effects depending on the phase of the spontaneous cycle (12).

Our findings seem to support the notion of "reactive sub-multiple periodicities" of the 24-hour rhythms since they become temporarily predominant in response to the loss and re-establishment of environmental time givers. However, further isolation experiments are required to demonstrate whether this is a general response or whether other subjects showing, under normal conditions, a more pronounced strength of 24-hour periodicities in the power spectrum analysis of physiological functions would not respond in this manner.

In reviewing the results of this isolation experiment one is struck by the contrast of the multitude of observed changes in the temporal organization of the two subjects and the paucity of changes in the average daily data, which stresses the importance of studies of cycles.

ACKNOWLEDGMENTS

The authors express their gratitude to the subjects for their excellent motivation and cooperation, and to Mrs. Nancy McCabe, Mr. M. Jacey, Miss E. Jordan, Mrs. A. Parker, Mrs. J. Withers for performing analyses of urine and saliva samples and assistance in the statistical computations.

REFERENCES

1. Aschoff, J. and R. Wever. Spontanperiodik des Menschen bei Ausschluss aller Zeitgeber. *Naturwissenschaften* 15: 337-342, 1962.
2. Aschoff, J. Significance of circadian rhythms for space flight. *Proc. Third International Symposium*, Ed. T. C. Bedwell, Jr. and H. Strughold. San Antonio, 1964.
3. Blume, T. Nachweis von Perioden durch Phasen- und Amplituden--diagramm, mit Anwendungen ans der Biologie, Medizin and Psychologie, *Forsch. ber. des Landes. Nordthein-Estfalen* 1489, Köln 1965.
4. Brown, Jr., F. A. A unified theory for biological rhythms: rhythmic duplicity and the genesis of "circa" periodisms. *CIRCADIAN CLOCKS*, p. 231-261, North Holland Publ., Amsterdam 1965.
5. *The Biology of Human Variation*. Ed. J. Brozek. *Annals of the New York Academy of Sciences*. 134: 497-1066, 1966.
6. Clegg, B. R. and K. E. Schaefer. "Studies of circadian cycles in human subjects during prolonged isolation in a constant environment using eight channel telemetry systems." SMRL Memo Report 64-4. Naval Submarine Medical Center, Groton, Conn.
7. Clegg, B. R. and K. E. Schaefer. "Measurement of periodicity and phase shift of physiological functions in isolation experiments by cross-correlation techniques using synthesized periodicities." *Aerospace Medicine*, 37: 271, 1966, p.271.(Abstract).
8. Cook, E. A factor analysis of personnel selection data: Intra- and Inter-area relationships of Biochemical, Physiological, Psychological and Anthropometric Measures. USN BUMED Task MRO05.14-2101, V. XI, No. 26, Dec 1961.
9. Halberg, F. Physiological 24-hour rhythms: A determinant or response to environmental agents. In: *Man's Dependence on the Earthly Atmosphere*. Ed. K. E. Schaefer. MacMillan Company, New York, 1962.
10. Hathaway, S. R. and J. C. McKinley. *The Minnesota Multiphasic Personality Inventory Manual* (revised edition). New York: Psychological Corporation.
11. Hellbrügge, T. "The development of circadian rhythms in infants." *Cold Spring Harbor Symposia on Quantitative Biology*. V. 25 *Biological Clocks*, pp.311-323, 1960.

12. Hildebrandt, G. Reaktive Perioden und Spontanrhythmik. Proc. 7th International Conference, Society Study of Biological Rhythms, Siena, 1960.
13. Kleitman, N. Sleep and Wakefulness. University of Chicago Press. Chicago, 1939.
14. Kleitman, N. and T. G. Englemann. "Sleep characteristics of infants." J. Appl. Physiol. 6: 269-282, 1953.
15. Kretschmer, E. Koerperbau und Charakter, J. Springer, Berlin, 1924.
16. Lobban, Mary C. "The entertainment of circadian rhythms in man." Cold Spring Harbor Symposia, 25, Biological Clocks, 1960, p.325-332.
17. Lobban, M. C. "Dissociation in human rhythmic functions." Circadian Clocks. Ed. J. Aschoff. Proceedings Feldafing Summer School. 1965 p. 219-227.
18. Meehl, P. E. Clinical versus Statistical Prediction. Univ. of Minnesota Press, 1954.
19. Menzel, W. "Periodicity in urinary excretion in healthy and nephropathic persons." Ann. N.Y. Acad. Sci., 98: 1007-1017, 1962.
20. Menzel, W., F. Blume and F. F. v. Schroeder. Klassifizierung Klinischer Verläufe durch Periodinanalyse. Zeitschr. Klin. Medizin. 155: 249-268, 1958.
21. Mills, J. N. Circadian rhythms during and after three months in solitude underground. J. Physiol. (London) 174: 217-231, 1964.
22. Mills, J. N. Human Circadian Rhythms, Physiol. Reviews, 46: 128-171, 1966.
23. Schaefer, K. E. and J. H. Dougherty, Jr., "Variability of respiratory functions based on circadian cycles." SMRL Report No. 486, 1966. U.S. Naval Submarine Medical Center, Groton, Connecticut.
24. Schaefer, K. E. In: Man's Dependence on the Earthly Atmosphere. Preface VII. MacMillan, New York, 1962.
25. Schrider, E. N. "Typology and Biometrics." Annal. N.Y. Acad. Sci. 134: 789-803, 1966.
26. Siffre, M. Hors du Temps. Paris; Julliard, 1963.

27. Sisakyan, N. M. and V. I. Yazdovskiy. First Group Flight into Outer Space. 11-15 Aug 1962, U. S. Dept. of Comm. JBRS. 25, 272, 1964.
28. Smith, K. T., E. W. Speckmann, G. M. Homer, W. W. Blanchard, and D. W. Dunco. Evaluation of the Biochemical and Physiological Effects of Confinement on Human Subjects. Aerospace Medical Research Laboratories, Aerospace Medical Division, Air Force Systems Command, Wright-Patterson Air Force Base, Ohio. Report AMRL-TR-66-2, 1966.
29. Weybrew, B. B. Patterns of psychophysiological response to military stress. In Appley, M. and Trumbull, R. (edits.) Psychological Stress: Issues in Research. Appleton-Century, 1966.
30. Weybrew, B. B. "An exploratory study designed to suggest clusters of traits and assessment tests related to submariner adjustment." U. S. Naval Medical Research Laboratory, Report No. 279, 1957.
31. Williams, R. J. Biochemical Individuality. John Wiley & Sons, New York, 1956.

Table 1

EFFECT OF ISOLATION IN A CONSTANT ENVIRONMENT ON AVERAGE DAILY
VALUES OF RESPIRATORY RATE, PULSE RATE AND BODY TEMPERATURE

		Control Period 4 days		Isolation Period 8 days		Recovery Period 3 days	
		Subj.D	Subj.G	Subj.D	Subj.G	Subj.D	Subj.G
Respiratory Rate	Mean*	20.8	21.3	19.4**	19.5**	20.4	20.0
	S.D.	.7	1.5	.4	.6	.1	1.6
Pulse Rate	Mean	62.5	70.5	61.1	68.5	67.0	70.7
	S.D.	3.3	1.5	3.1	2.8	1.8	1.0
Body Tem- perature	Mean	27.5	37.0	37.5	37.2	37.6	37.3
	S.D.	.2	.2	.1	.1	.1	.1

* Daily means are based on 96 values (15 min. recordings)

** Different from controls at the 5% level and better

Table 2

EFFECT OF ISOLATION IN A CONSTANT ENVIRONMENT
ON AVERAGE DAILY URINARY EXCRETION

		Control period (4 days)		Isolation period (8 days)		Recovery period (3 days)	
		Subj.D	Subj.G	Subj.D	Subj. G	Subj.D	Subj. G.
1) Urinary Volume ml/hour	Mean	59.30	68.85	62.55	51.53	40.04**	60.25
	S.D.	19.55	13.45	13.66	8.64	8.51	4.60
2) 17-Keto- steroids mg/hour	Mean	1.68	1.30	2.45*	1.03*	1.44**	.82
	S.D.	.42	.12	.54	.22	.37	.16
3) Sodium mEq/hour	Mean	9.98	8.64	8.45	7.66	6.66	5.83
	S.D.	4.36	3.14	1.98	.83	1.44	.94
4) Potassium mEq/hour	Mean	3.55	2.80	3.25	2.17	2.14	3.37
	S.D.	.45	1.08	.58	.22	.60	1.63
5) Chloride mEq/hour	Mean	10.05	7.96	7.71	7.36	6.73	5.84
	S.D.	4.23	2.41	2.30	1.17	.70	1.19
6) Calcium mg/hour	Mean	.37	.43	.50	.52	.22**	.55
	S.D.	.17	.02	.18	.16	.04	.42
7) Total Nitrogen	Mean	99.3	78.9	122.4	87.5	71.3**	98.5
	S.D.	21.5	3.3	32.0	17.9	14.7	41.8
8) Ammonia mg/hour	Mean	24.5	12.2	25.4	17.6	14.2**	15.0
	S.D.	5.7	3.6	4.7	4.0	2.4	6.2
9) Uric Acid mg/hour	Mean	70.6	36.6	42.6	32.9	14.5**	14.1**
	S.D.	33.1	8.5	3.8	7.7	5.2	4.1

*Isolation data: Statistically different from controls at 5% level and better.

**Recovery data: Statistically different from data obtained during the control and the isolation period at 5% level and better.

Table 3

EFFECT OF ISOLATION IN A CONSTANT ENVIRONMENT ON
AVERAGE DAILY VALUES OF SALIVARY CONSTITUENTS

		Control period		Isolation period		Recovery period	
		4 days		8 days		3 days	
		Subj.D	Subj.G	Subj.D	Subj. G	Subj.D	Subj.G
Chloride Meq/L	Mean	12.5	18.2	13.3	22.4	13.9	23.8*
	S.D.	1.2	1.6	2.2	2.8	2.2	.9
Sodium Meq/L	Mean	12.8	18.4	9.9	21.0	13.2	19.3
	S.D.	3.5	3.4	4.1	4.2	2.0	.8
Potassium Meq/L	Mean	18.3	26.1	18.5	26.0	17.1	25.8
	S.D.	.8	1.4	.8	1.0	.9	.2
Uric Acid Meq/L	Mean	3.61	2.90	3.77	2.89	3.37	2.08
	S.D.	.33	.07	.50	.96	.37	.38

* Statistically different from controls at 5%
level and better

Table 4

MEAN LENGTH (HR) OF THE "PHYSIOLOGICAL DAY" AS INDICATED
IN CYCLE LENGTH OF VARIOUS PHYSIOLOGICAL FUNCTIONS
DURING EIGHT DAYS OF ISOLATION IN A CONSTANT ENVIRONMENT

	<u>Subject G</u>	<u>Subject D</u>
Sleep-wakefulness cycle (morning)	25.75 ± 0.78	25.75 ± 0.78
Respiratory rate	24.5 ± 1.4	24.0 ± .9 *(.01)
Pulse rate	25.0 ± 1.1	23.5 ± 1.7 *(.01)
Core temperature	24.6 ± 1.2	23.7 ± .8 *(.01)
Basal skin resistance	23.9 ± 3.7	24.7 ± 3.6
Urine volume	24.8 ± 1.30	24.4 ± 2.18
Urine sodium	25.10 ± 1.47	24.3 ± 1.24 *(.05)
Urine potassium	24.70 ± .44 *(.01)	24.0 ± .78 *(.001)
Urine chloride	25.0 ± 1.60	24.5 ± 1.42
Urine 17-ketosteroid	24.70 ± 1.69	24.9 ± 2.41
Urine total nitrogen	24.0 ± 1.77	25.4 ± 1.28
Urine calcium	23.8 ± 1.32 *(.01)	26.9 ± 4.45
Urine ammonia	24.7 ± 1.68	25.2 ± .95
Uric acid	24.6 ± 3.58	24.6 ± 2.27
Saliva sodium	24.2 ± 1.1 *(.01)	25.3 ± 1.7
Saliva chloride	25.1 ± 1.3	26.7 ± 3.4
Saliva potassium	24.0 ± 1.4 *(.001)	25.4 ± 1.8
Saliva uric acid	24.2 ± 2.7	24.6 ± 1.6

Number of observations - 8

*Statistically significantly different from average lengths of
sleep-wakefulness cycle

P values are listed in parenthesis

Table 5

EFFECT OF ISOLATION IN A CONSTANT ENVIRONMENT ON AVERAGE DAILY AMPLITUDE OF CIRCADIAN CYCLES OR RESPIRATORY RATE, PULSE RATE, BODY TEMPERATURE, AND AVERAGE DAILY VARIATIONS OF PERFORMANCE TEST SCORES

		Control period 4 days		Isolation period 8 days		Recovery period 3 days	
1. Respiratory rate	Subj.D	13	\pm 1.2	10	\pm 2.7	14	\pm 5.5
	Subj.G	15	\pm 1.0	15	\pm 3.9	15	\pm 4.2
2. Pulse Rate	Subj.D	43	\pm 4.6	46	\pm 7.6	47	\pm 11.8
	Subj.G	52	\pm 10.4	52	\pm 12.5	52	\pm 3.8
3. Body temperature in °C	Subj.D	1.08	\pm .15°C	1.05	\pm .23°C	1.05	\pm .23°C
	Subj.C	1.54	\pm .17°C	1.18	\pm .15°C	1.18	\pm .12°C
4. Hand steadiness	Subj.D			6	\pm 6 (6)		
	Subj.G			17	\pm 19 (6)		
5. Hand Coordination	Subj.D			12.5	\pm 7 (6)		
	Subj.G			27	\pm 26 (6)		

LEGENDS

- Figure 1. Comparison of MMPI score profiles for Subjects G and D.
- Figure 2. Schematic diagram of the climatized pressure altitude chamber used for isolation experiments in a constant environment.
- Figure 3. Schematic diagram of the telemetry data acquisition system.
- Figure 4. Shift in total daily periodicity (sleep-wakefulness cycle) of two subjects during isolation in a constant environment. Average daily periodicity 25.75 hours measured at the time of awakening.
- Figure 5. Circadian periodicity of body temperature of two subjects during isolation in a constant environment. (Control period and first four days of isolation). Based on recordings made at 15 minute intervals.
- Figure 6. Circadian periodicity of body temperature of two subjects during isolation in a constant environment. (Fifth to ninth day of isolation and subsequent three day recovery period). Based on recordings made at 15 minute intervals.
- Figure 7. Circadian periodicity of pulse rate of two subjects during isolation in a constant environment. Based on recordings made at 15 minute intervals.
- Figure 8. Simultaneous records of respiratory rate, pulse rate, basal skin resistance and core temperature. Data recorded at one minute intervals and smoothed by moving average over 15 points (15 minutes). Stippled area - sleeping period, lights out. Last control day prior to isolation. Subj. G.
- Figure 9. Simultaneous records of respiratory rate, pulse rate, basal skin resistance and core temperature. Data recorded at one minute intervals and smoothed by moving average over 15 points (15 minutes). Stippled area - sleeping period, lights out. Subj. G. Seventh day of isolation.
- Figure 10. Circadian cycles of urinary excretion in two subjects during isolation in a constant environment. (Urine volume, sodium potassium, chloride, uric acid and 17 ketosteroids.)
- Figure 11. Circadian cycles of saliva constituents and flow rate in two subjects during isolation in a constant environment. Note that subject D, whose urinary excretion was higher, shows lower levels of saliva sodium, potassium and chloride.

- Figure 12. Psychomotor data of two subjects during isolation in a constant environment. (Scores of hand steadiness tests, aiming tests, hand coordination and data on flicker fusion thresholds.)
- Figure 13. Phase shifts of circadian cycles of respiratory rate and heart rate of two subjects during isolation in a constant environment. Based on cross-correlation analysis with synthesized 24-hour sinusoids.
- Figure 14. Phase shifts of circadian cycles of core temperature and basal skin resistance of two subjects during isolation in a constant environment. Based on cross-correlation analysis with synthesized 24-hour sinusoids.
- Figure 15. Phase shifts of circadian cycles of urine functions (urine volume, sodium, potassium, chloride, 17 ketosteroids, total nitrogen, uric acid) in two subjects during isolation in a constant environment. Based on cross-correlation analysis with synthesized 24-hour sinusoids.
- Figure 16. Spectrum estimates of respiratory rate, pulse rate, core temperature and basal skin resistance of Subj. D during isolation in a constant environment. The individual frequencies listed actually represent frequency bands. Four frequency ranges 1) black bars, 24 hours equal frequency band 20-36 hours, 2) white bars, 12 hours equal frequency band 11-14 hours, 3) cross hatched bars, 6 hours equal frequency band 5.7-6.5 hours, 4) stippled bars, 2 hours equal frequency band 1.95-2.05 hours.
- Figure 17. Spectrum estimates of respiratory rate and pulse rate of Subj. G during isolation in a constant environment. The individual frequencies listed actually represent frequency bands. Four frequency ranges, 1) black bars, 24 hours equal frequency band 20-36 hours, 2) white bars, 12 hours equal frequency band 11-14 hours, 3) cross hatched bars, 6 hours equal frequency band 5.7-6.5 hours, 4) stippled bars, 2 hours equal frequency band 1.95-2.05 hours.

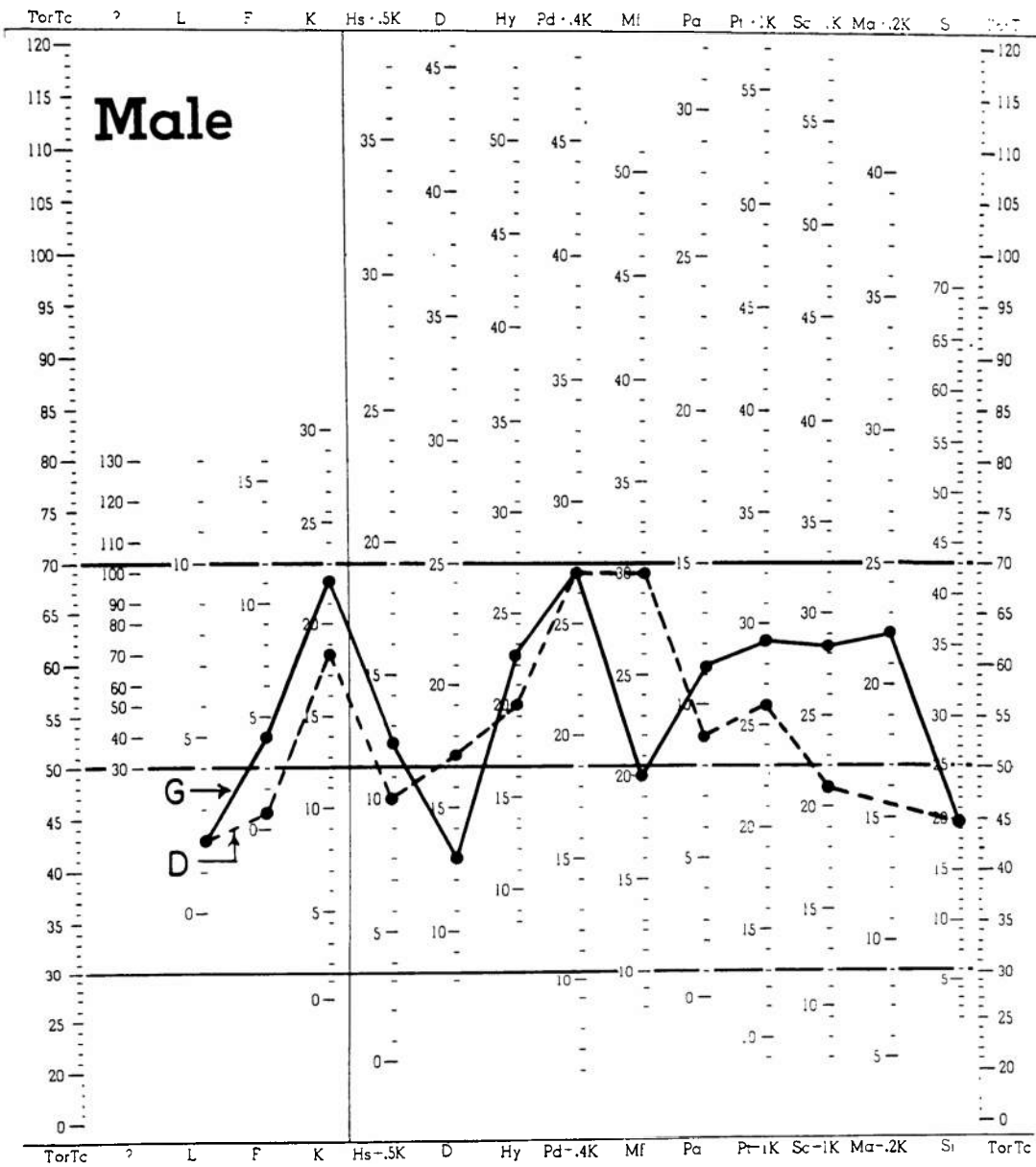
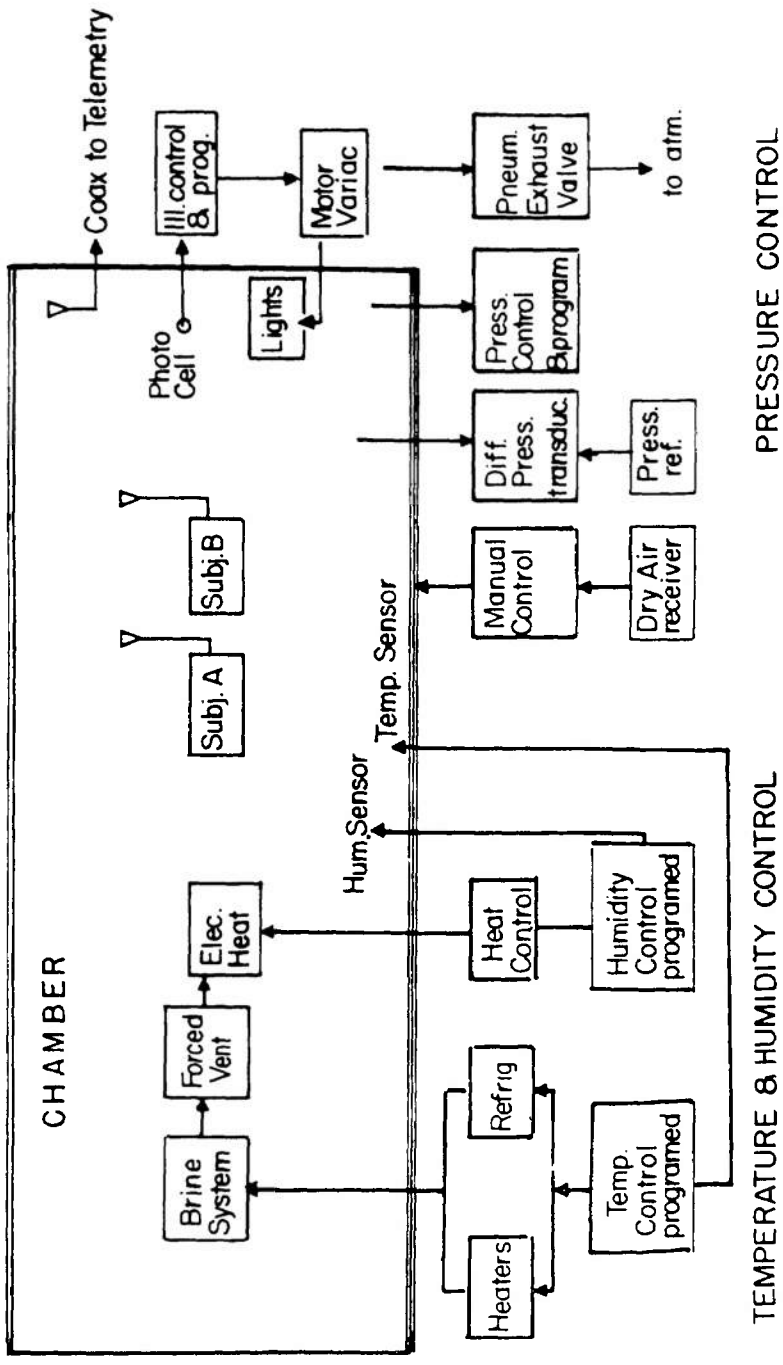

Fig. 1 Comparison of MMPI score profiles for Subjects G and D.



CHAMBER

PRESSURE CONTROL

TEMPERATURE & HUMIDITY CONTROL

TELEMETERED DATA ACQUISITION

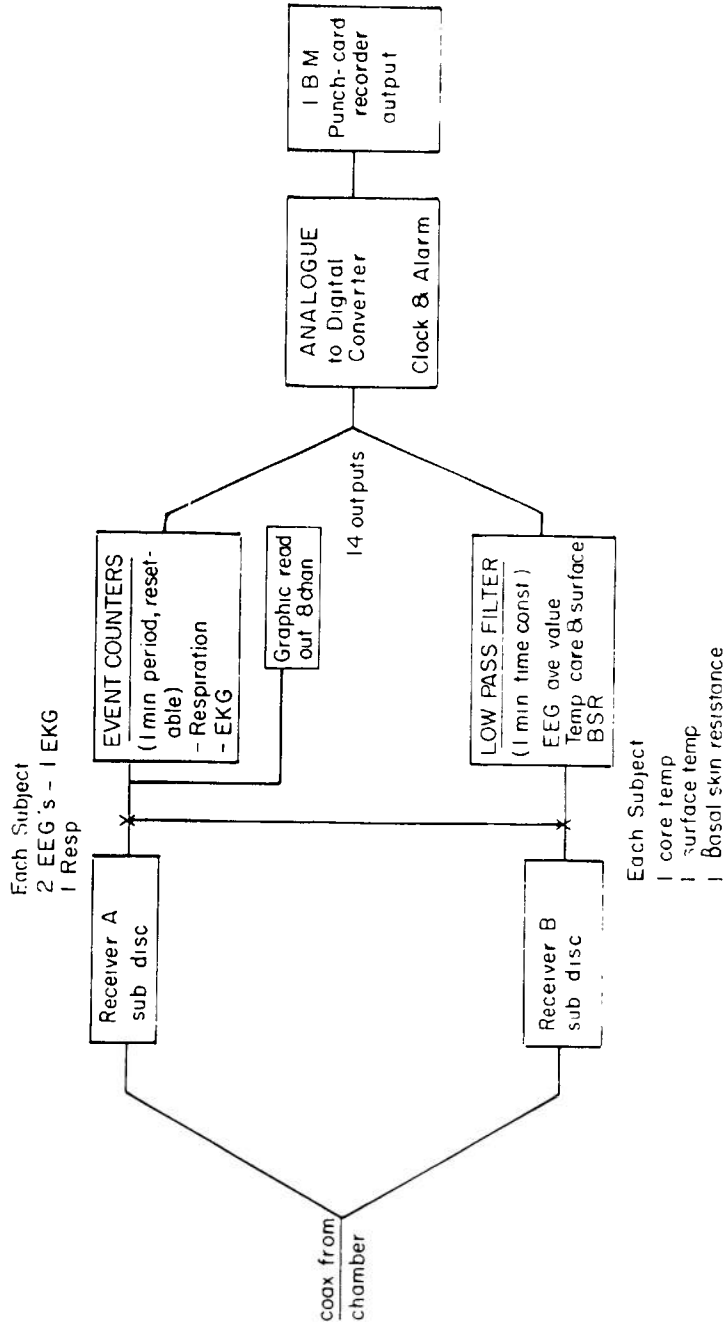

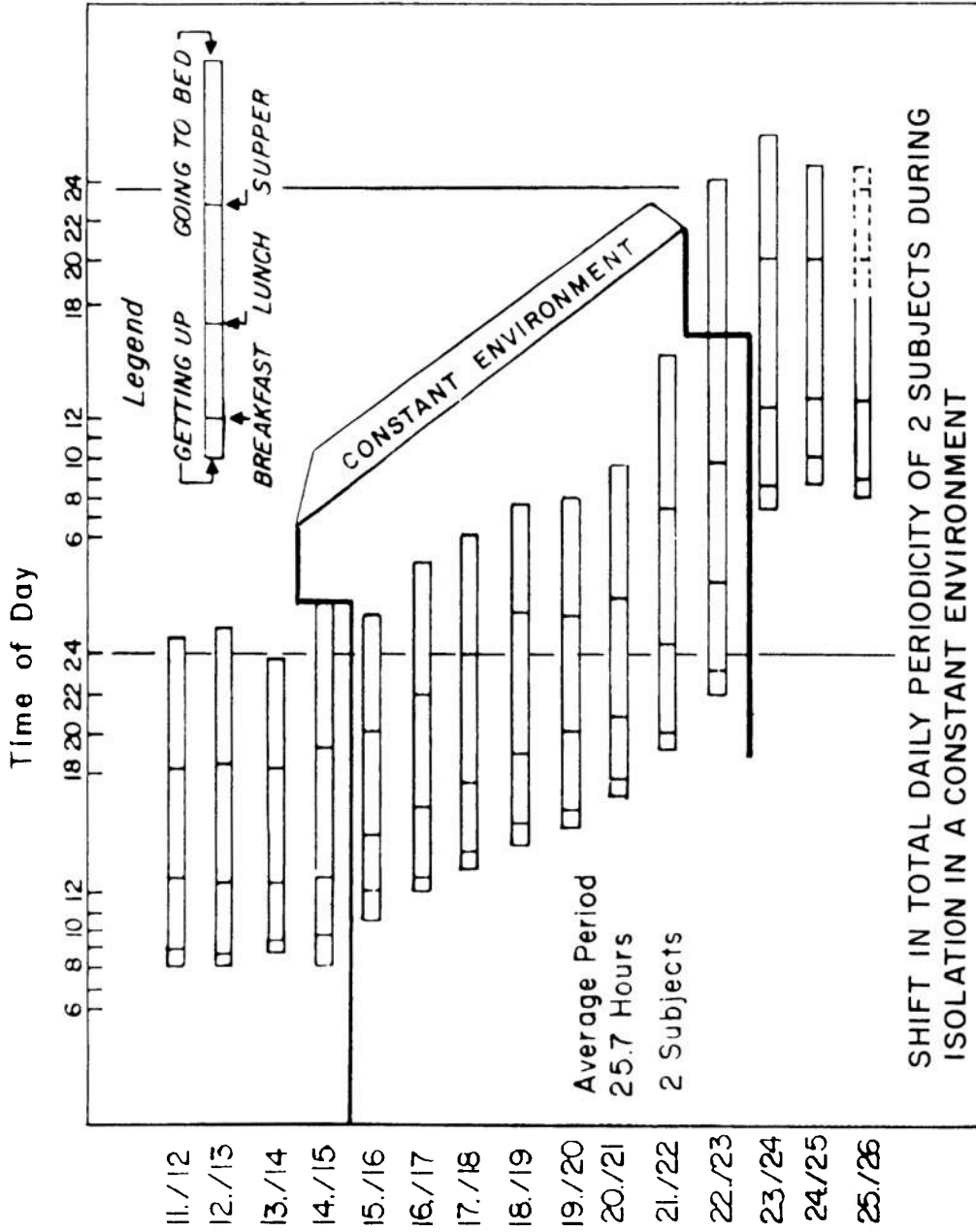

CIRCADIAN PERIODICITY OF BODY TEMPERATURE DURING ISOLATION
 IN A CONSTANT ENVIRONMENT: Subject DA. — Subject GR.---

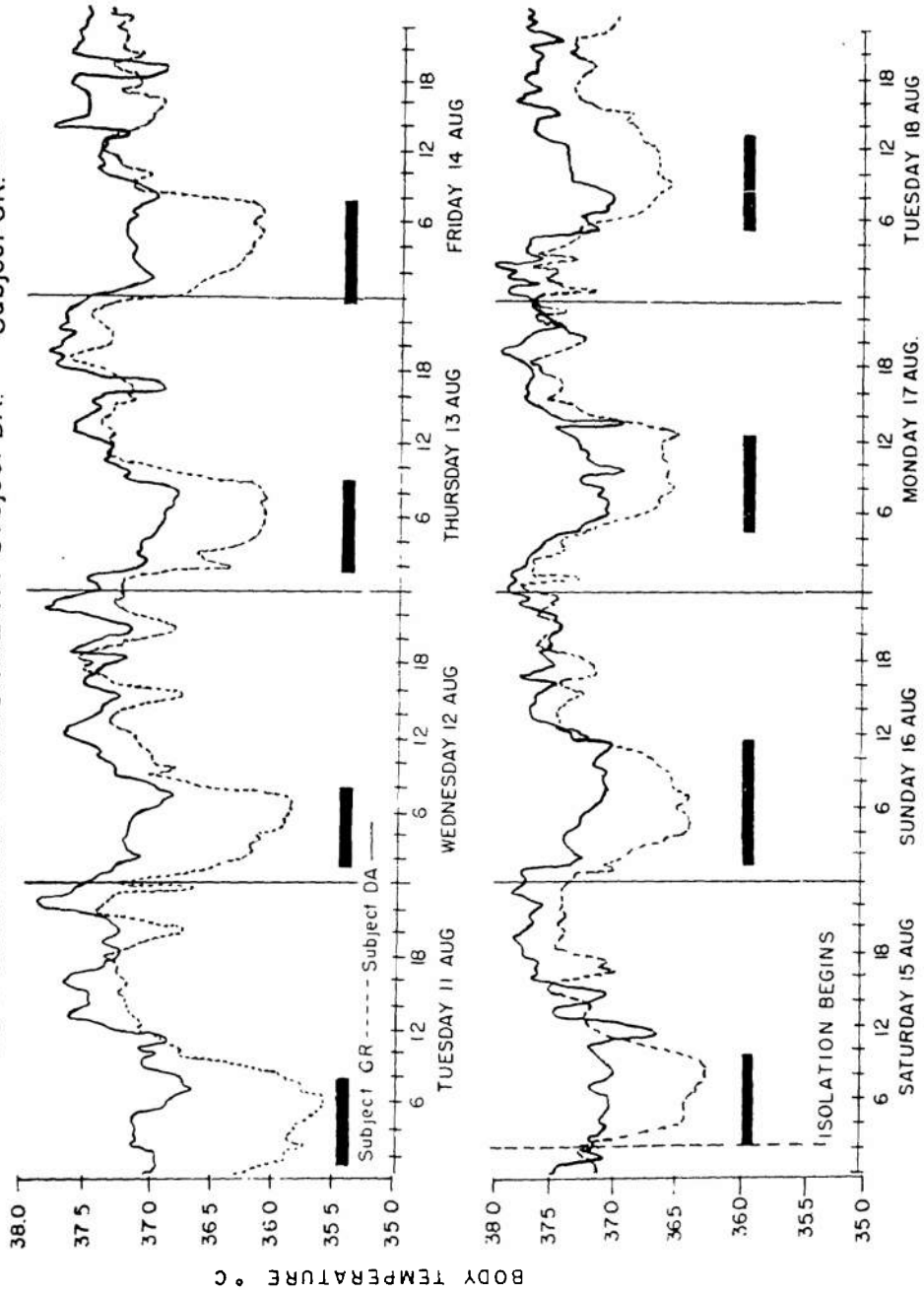

CIRCADIAN PERIODICITY OF BODY TEMPERATURE DURING ISOLATION
 IN A CONSTANT ENVIRONMENT: Subject DA — Subject GR ---

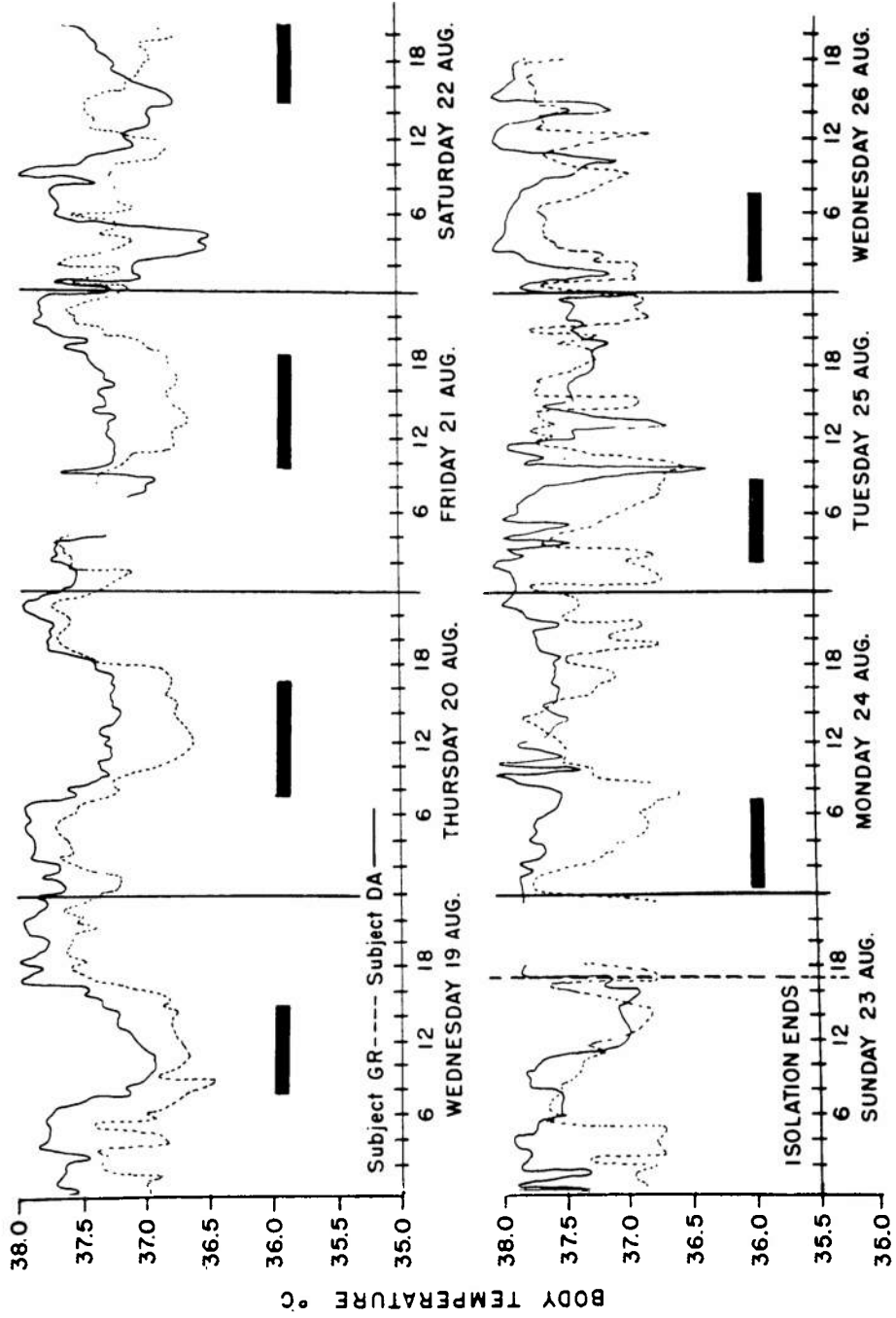

SUBJECT DA *|——
SUBJECT GR *|-----

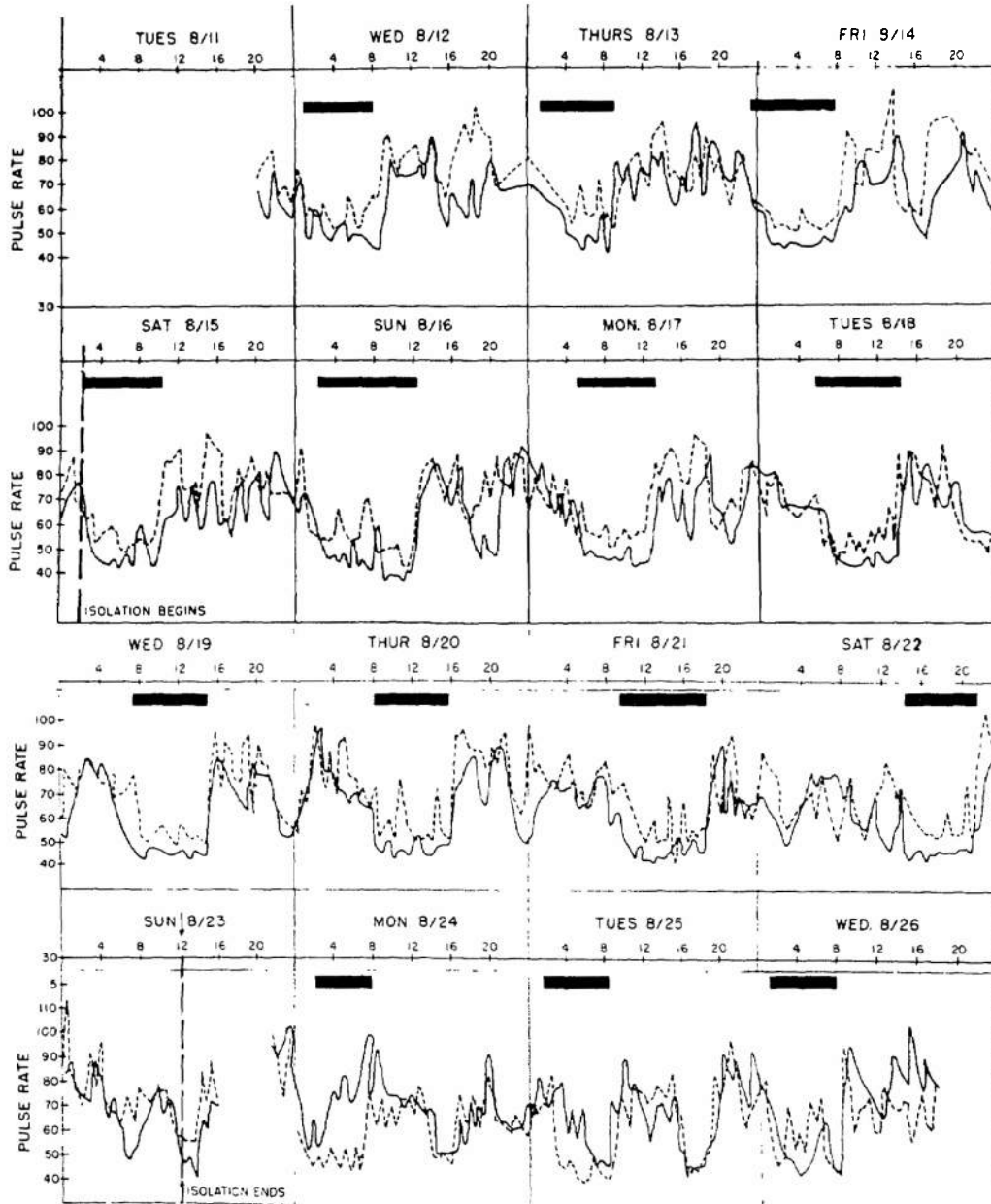

CONTROL

Subj.-G.

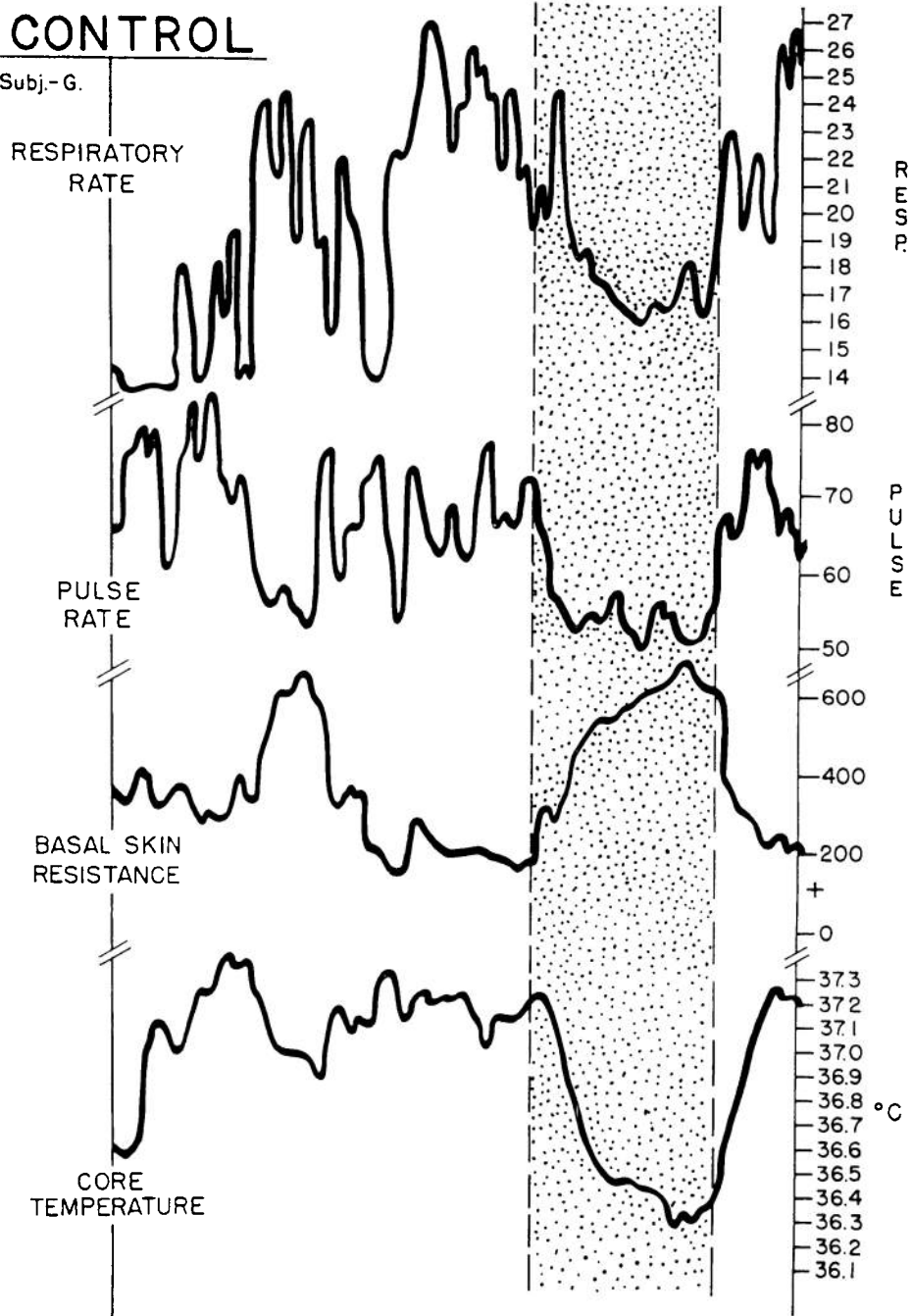

7th DAY OF ISOLATION

(WITH NORMAL PHYSICAL ACTIVITY)

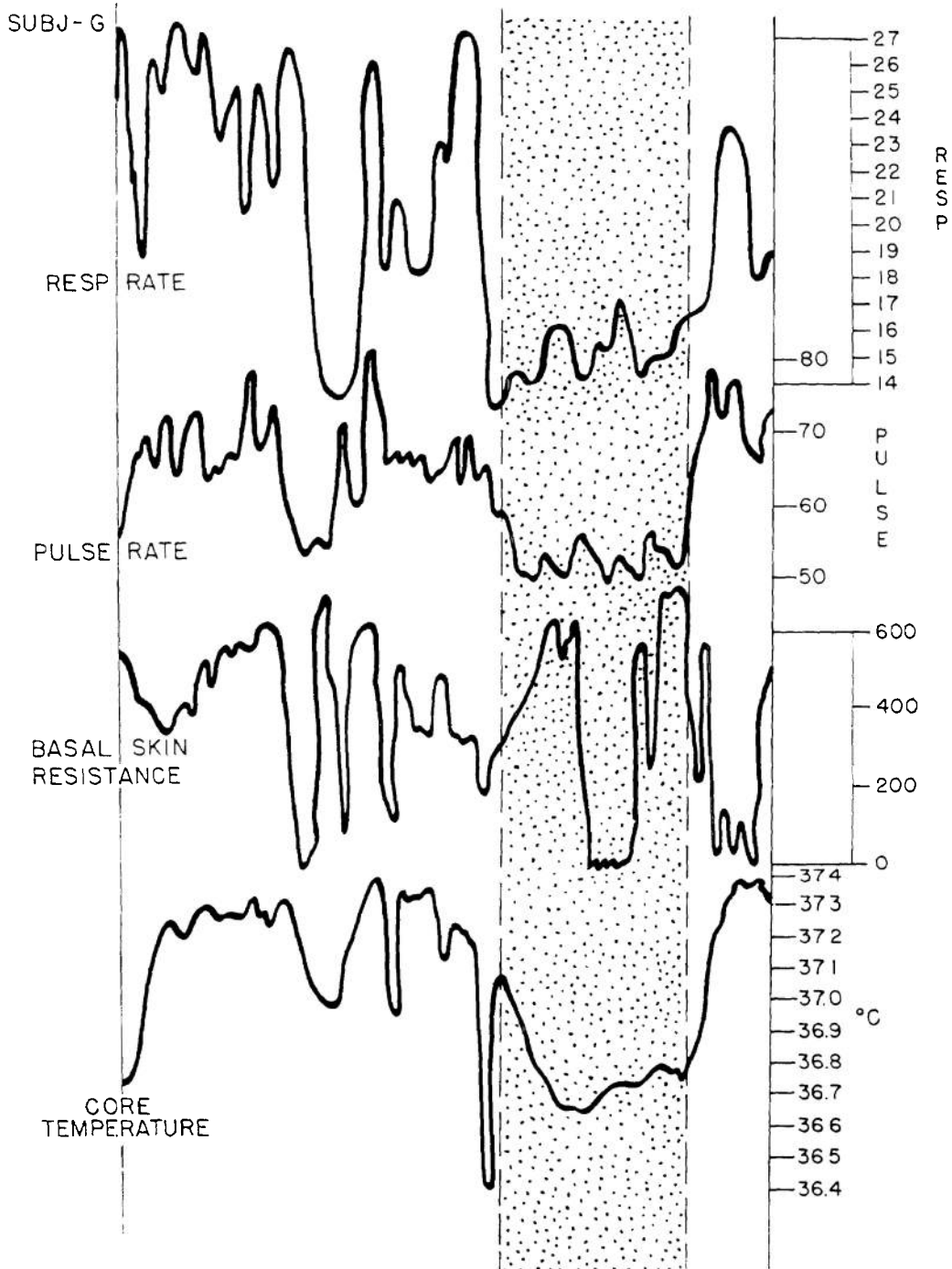

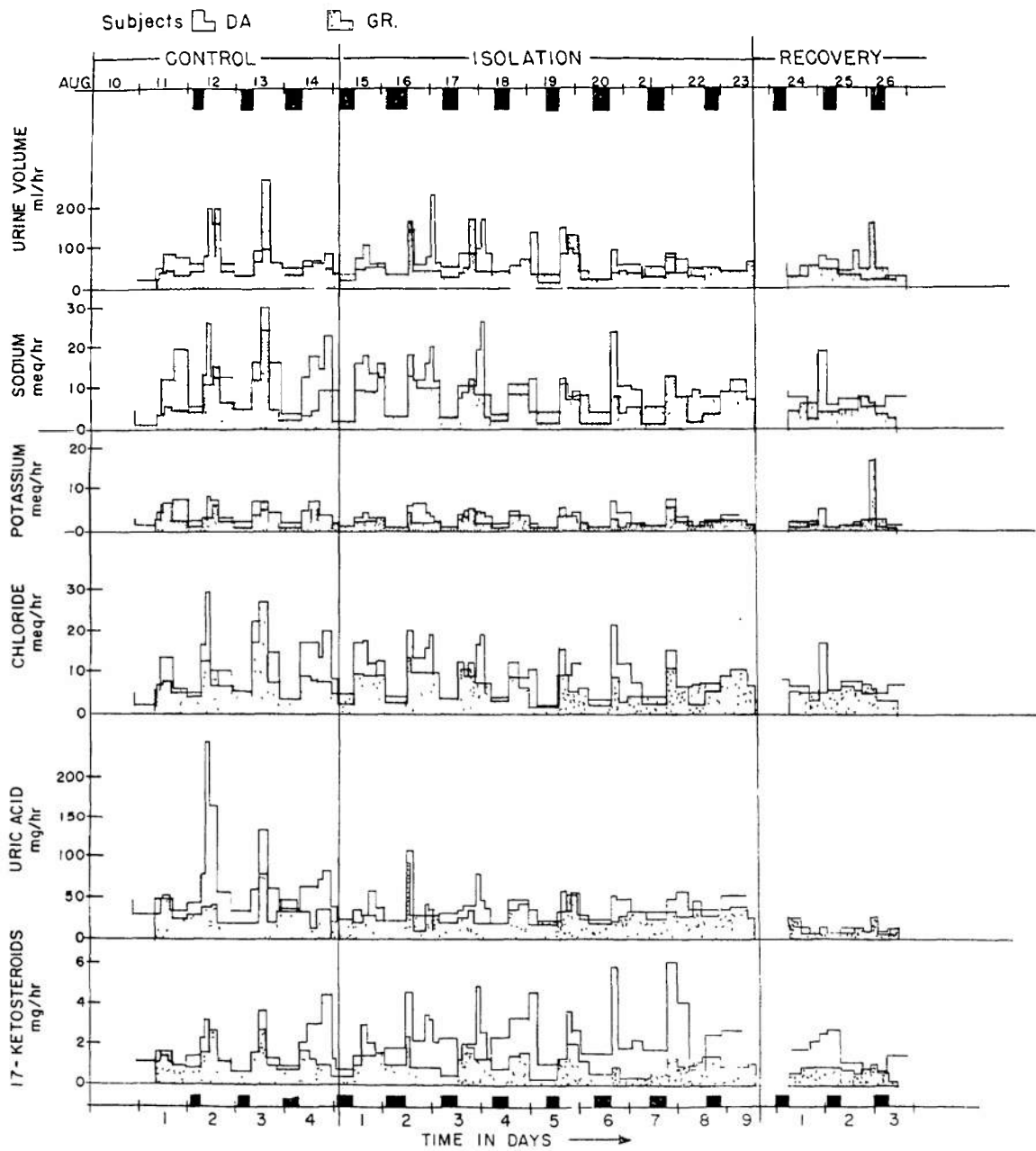

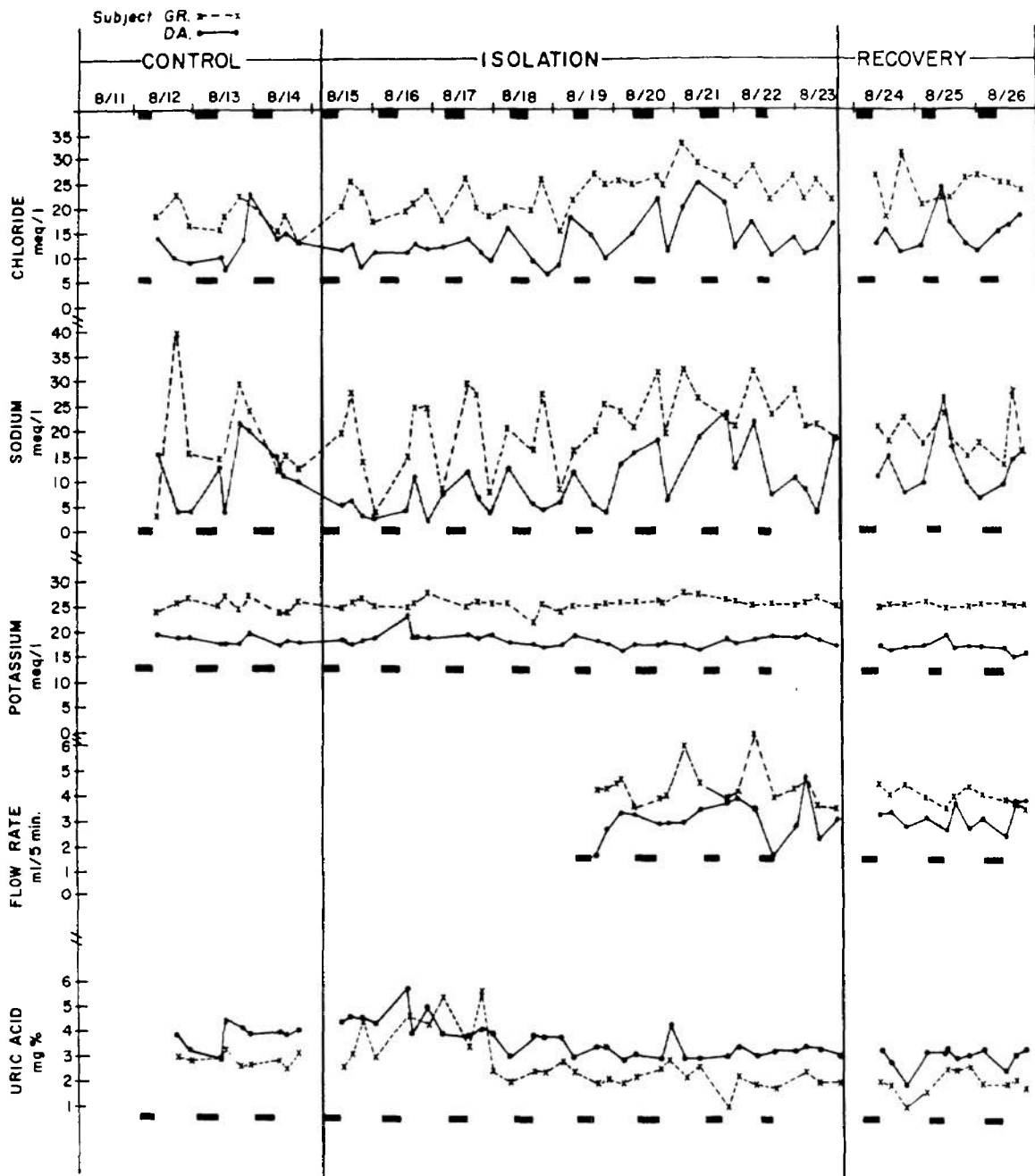

CIRCADIAN PERIODICITY OF SALIVA CONSTITUENTS AND FLOW RATE DURING ISOLATION IN A CONSTANT ENVIRONMENT

SUBJECT GR---

PSYCHOMOTOR DATA

SUBJECT DA—

DOOR CLOSED

ISOLATION

DOOR OPENED

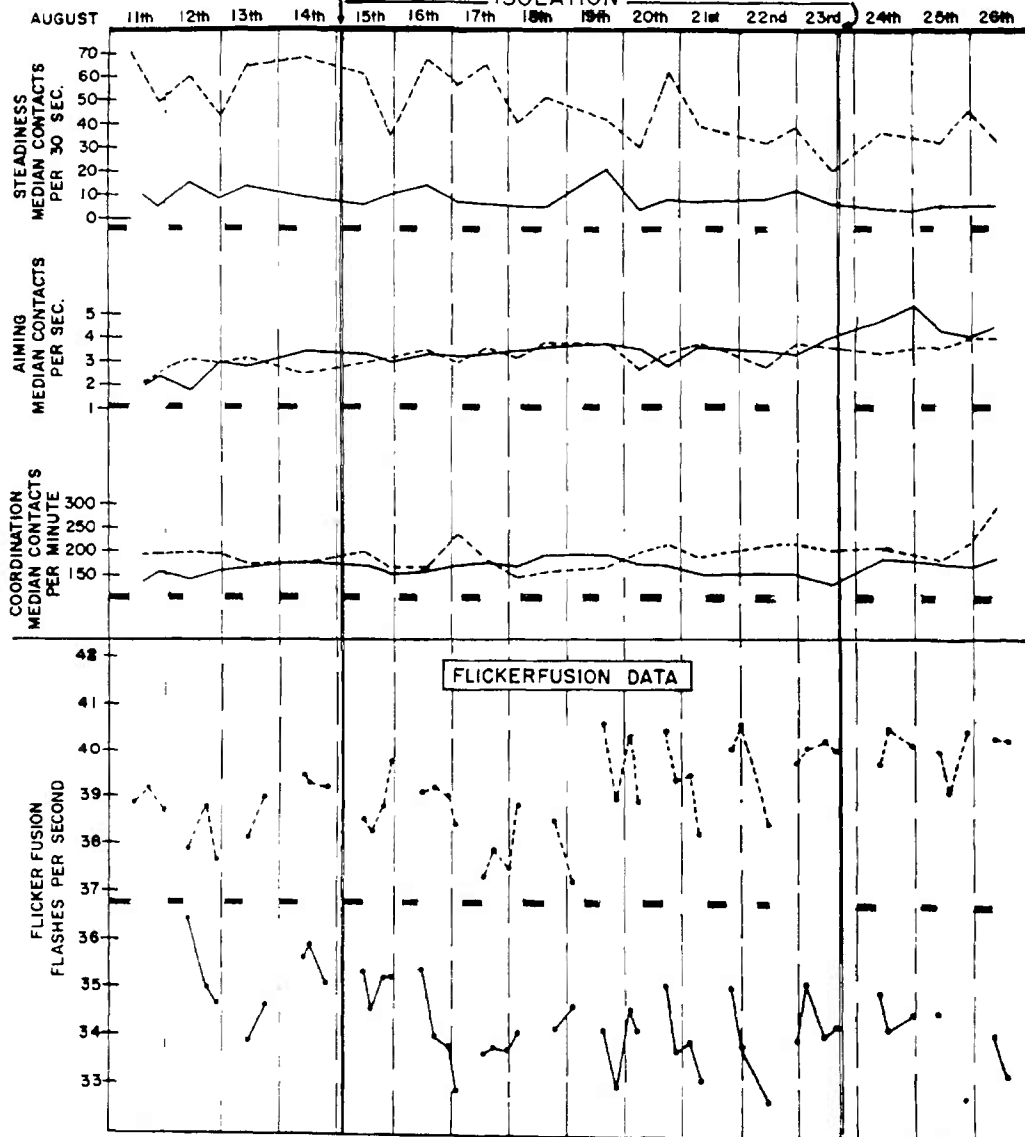

Phase Shifts of Respiration Rate and Heart Rate Cycles - Cross Correl. Analysis

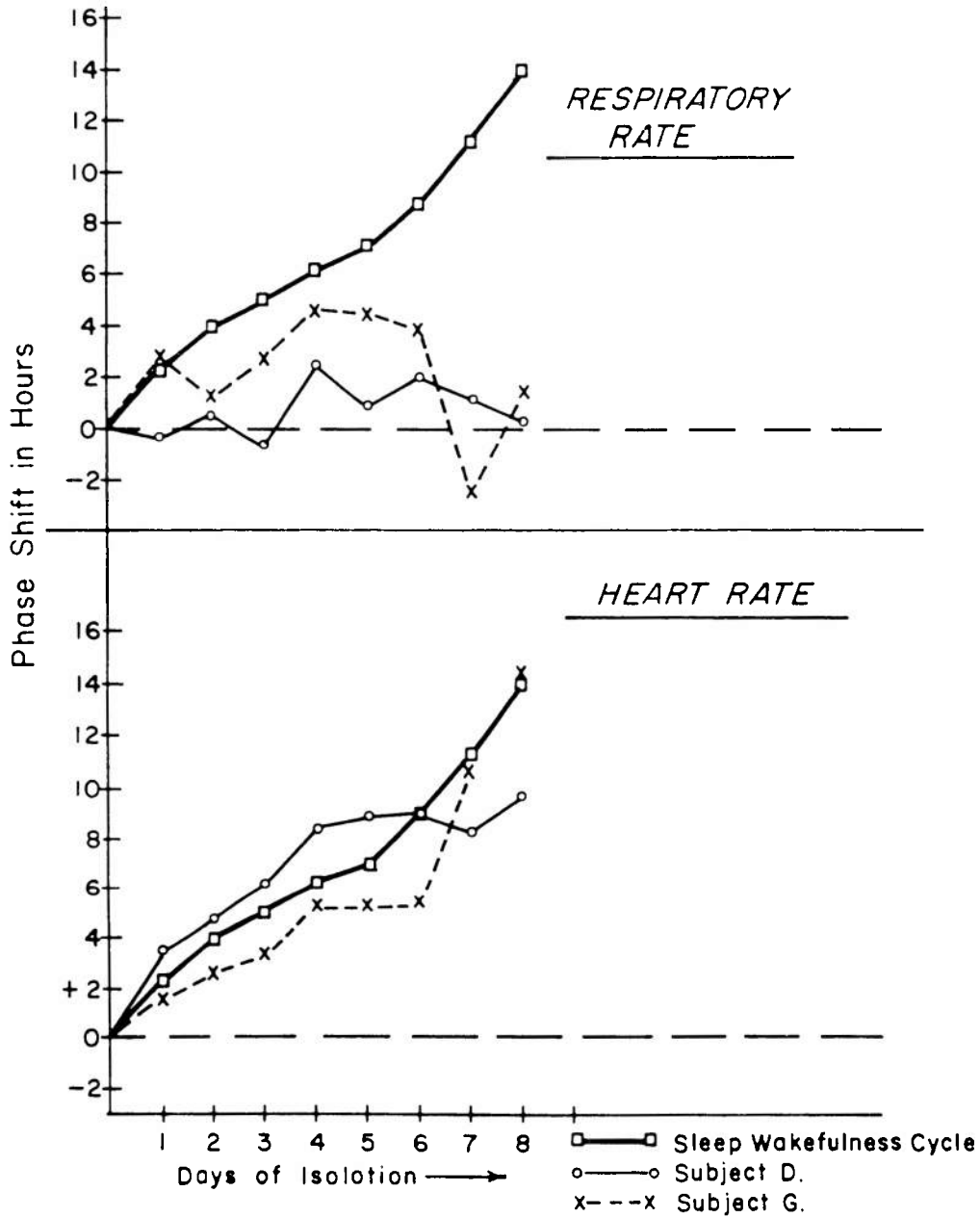

Phase Shift of Circadian Cycles of Urinary Functions During Isolation

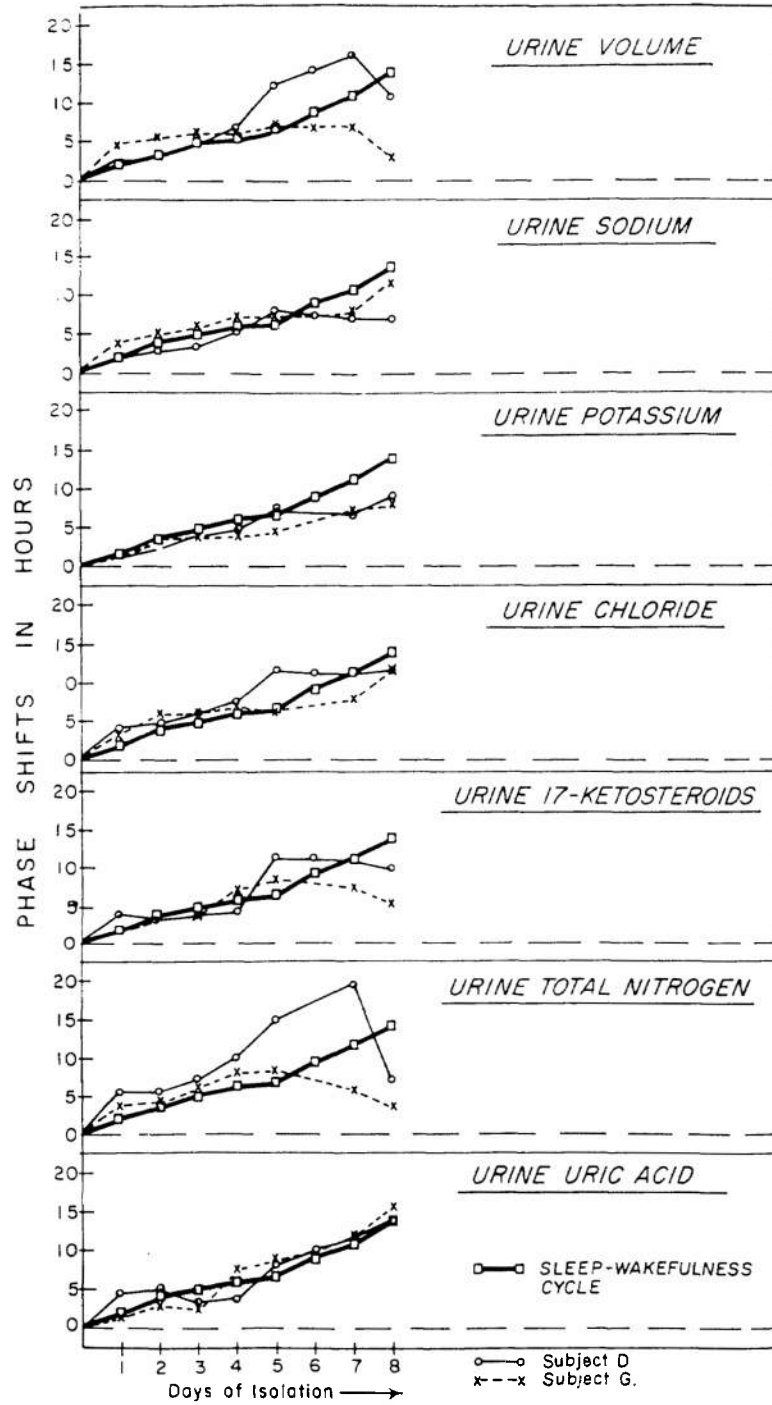

SUBJECT D

■	24 HR COMPONENT
▨	12 " "
▧	6 " "
□	2 " "

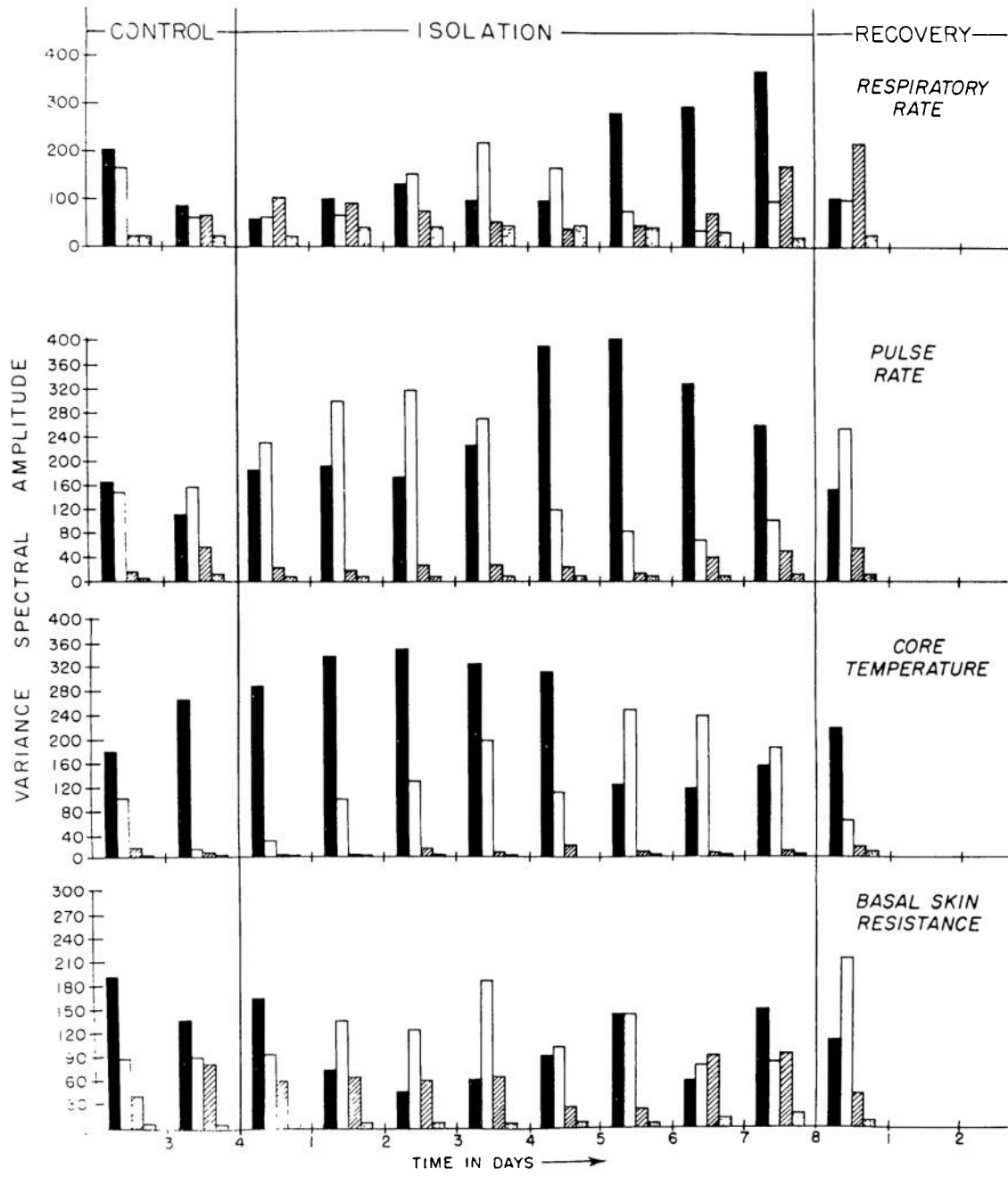

24 hr. COMPONENT
 12 " "
 6 " "
 2 " "
 SUBJECT G.

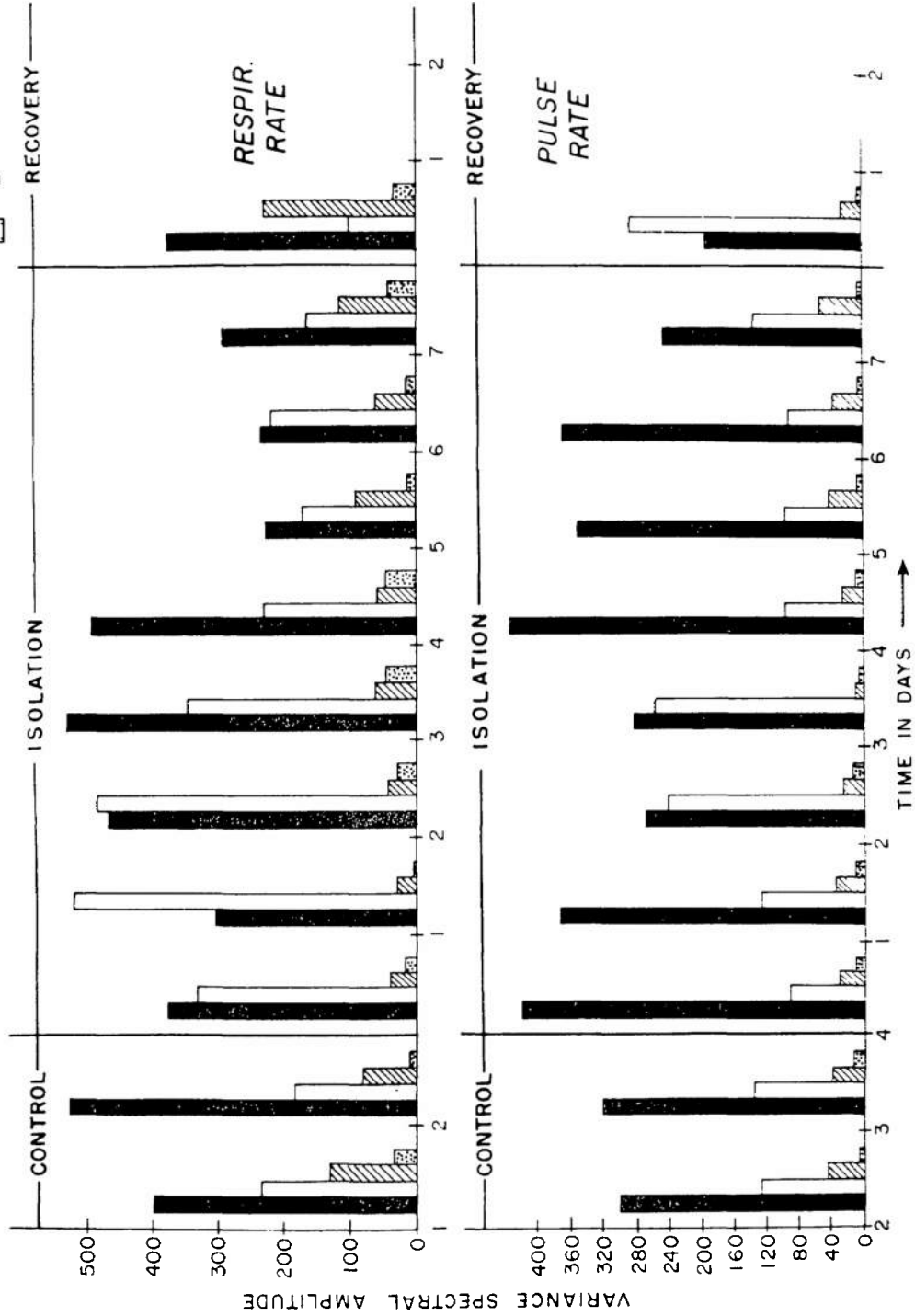

UNCLASSIFIED

Security Classification

DOCUMENT CONTROL DATA - R & D

(Security classification of title, body of abstract and indexing annotation must be entered when the overall report is classified)

ORIGINATING ACTIVITY (Corporate author)

U.S. Naval Submarine Medical Center, Submarine Medical Research Laboratory
Report with Off. of Adv. Research & Tech., NASA)

2a. REPORT SECURITY CLASSIFICATION

UNCLASSIFIED

2b. GROUP

REPORT TITLE

Effect of Isolation in a Constant Environment on Periodicity of Physiological Functions and Performance

DESCRIPTIVE NOTES (Type of report and inclusive dates)

Interim report

AUTHOR(S) (First name, middle initial, last name)

Karl E. Schaefer, Bruce R. Clegg, Charles R. Carey, J. H. Dougherty, and Benj. B. Weybrew

REPORT DATE

Feb 1967

7a. TOTAL NO. OF PAGES

29

7b. NO. OF REFS

31

CONTRACT OR GRANT NO.

NASA Order R-24

9a. ORIGINATOR'S REPORT NUMBER(S)

SMRL Report No. 468

OBJECT NO.

005.04-0058.03

9b. OTHER REPORT NO(S) (Any other numbers that may be assigned this report)

DISTRIBUTION STATEMENT

For unlimited distribution

SUPPLEMENTARY NOTES

12 SPONSORING MILITARY ACTIVITY

Naval Submarine Medical Center
Box 600 Naval Submarine Base
Groton, Conn. 06340

ABSTRACT

In an effort to determine the extent to which the day/night cycles of physiological and psychological functions normally synchronized with the environment in 24-hour cycles might change in isolation in an environment where there were no external clues, two medical students were studied. These subjects were isolated for nine days in a constant environment, in which temperature, humidity, barometric pressure, light intensity, and noise levels were closely controlled. In brief, the findings showed that they experienced a shift of 1.7 hours away from local clock time. Their average total periodicity being 25.8 hours. The cycles of body temperature, pulse rate, and basal skin resistance followed the phaseshift of the sleep-awakefulness cycle, while the cycle of respiratory rate became dissociated in both subjects. Most of the urine functions remained synchronized for five days but dissociated from the sleep-awakefulness cycle during the subsequent three days of the isolation period. The two subjects were of different body build and demonstrated distinctly different personality trait configurations, which were reflected in their temporal organization. Twelve-hour and six-hour periodicities were shown by power spectral analysis to dominate temporarily the 24-hour periodicity during the adjustment to and recovery from the effects of isolation, in heart-rate, body temperature, and basal skin resistance, and respiratory rate of both subjects. This temporary breakdown of the temporal organization might be involved in the subjectively experienced difficulties of adjustment to living in a constant environment.

UNCLASSIFIED

Security Classification

14 KEY WORDS	LINK A		LINK B		LINK C	
	ROLE	WT	ROLE	WT	ROLE	WT
Isolation in a constant environment, effects of Diurnal cycles in man, effect of constant environment on Sleep/wakefulness cycle, effect of constant environmt						

UNCLASSIFIED

Security Classification