



AD 648417

**RESEARCH AND DEVELOPMENT
OF BLAST PROTECTIVE FOOTWEAR,
FABRICATION AND PROOFTESTING**

Reproduced From
Best Available Copy

by

E. S. Fujinaka and J. L. MacDonald

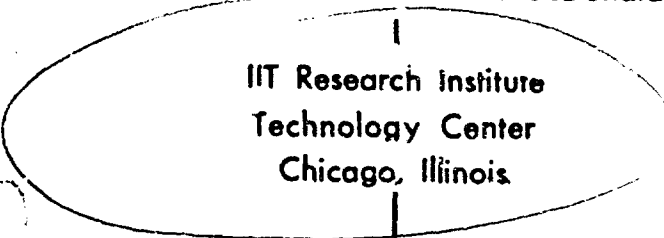

IIT Research Institute
Technology Center
Chicago, Illinois

Contract No. DA19-129-QM-2061 (OI 6137)

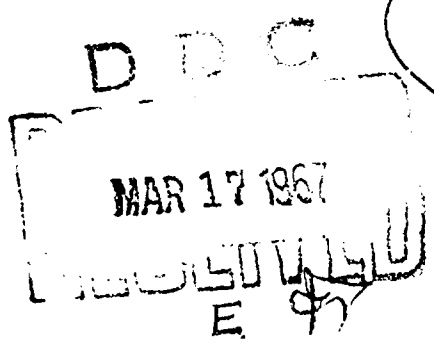

July 1966



UNITED STATES ARMY
NATICK LABORATORIES
Natick, Massachusetts 01760



ARCHIVE COPY

Clothing and Organic Materials Division
TS-141

ACCESSION LT	
OPST	WHITE SECTION
DDC	BLUE SECTION
UNANNOUNCED JUSTIFICATION	
BY	
GSA SECTION/AVAILABILITY	
DIST.	AVAIL. AND/OR S...

DISTRIBUTION OF THIS DOCUMENT IS UNLIMITED.

The findings in this report are not to be construed as an official Department of the Army position unless so designated by other authorized documents.

Citation of trade names in this report does not constitute an official indorsement or approval of the use of such items.

Destroy this report when no longer needed. Do not return it to the originator.

Distribution of this
document is unlimited

AD _____

TECHNICAL REPORT
67-5-CM

RESEARCH AND DEVELOPMENT OF BLAST PROTECTIVE FOOTWEAR,
FABRICATION AND PROOFTESTING

by

E. S. Fujinaka and J. L. MacDonald

IIT Research Institute
Technology Center
Chicago, Illinois 60616

Contract No. DA 19-129-QM-2061 (OI 6137)
IITRI Project No. E276

Project reference:
7-79-10-002

Series: TS-141

July 1966

Clothing and Organic Materials Division
U. S. ARMY NATICK LABORATORIES
Natick, Massachusetts 01760

FOREWORD

This is the second phase of a two-part report covering the research and development of protective footwear that will reduce to a tolerance level injury sustained by personnel exposed to the blast effects of an M-14 anti-personnel mine. This research and development project has resulted in a considerable advance in the state of the art of protective footwear, and the results are already being applied in the manufacture of anti-personnel mine protective combat boots for use in Southeast Asia.

This report was prepared by IIT Research Institute (formerly Armour Research Foundation) under Contract No. DA-19-129-QM-2061 (016137) under the leadership of E. S. Fujinaka and J. L. MacDonald. Personnel from the Experimental Operations Section of IITRI contributed to the fabrication portion of the program. The contract was initiated under Project No. 7-79-1Q-002 and was administered under the direction of the Clothing & Organic Materials Division of the U.S. Army Natick Laboratories, with Mr. Edward R. Barron acting as Project Leader and Mr. Douglas Swain as Alternate Project Officer.

The cooperation of Mr. George M. Stewart of CRDL, who conducted the blast evaluation program; Dr. James E. Beyer, Arlington Hospital, Arlington, Va.; Col. John J. Kovoric, Surgeon General's Office; Col. James D. Caskis, Kirk Army Hospital, Aberdeen Proving Grounds, who performed the autopsy damage assessments; and Mr. C. Vanetta of Genesco for footwear construction modification, is gratefully acknowledged.

APPROVED:

S. J. KENNEDY
Director
Clothing & Organic Materials Division

DALE H. SIELING, Ph.D.
Scientific Director

W.M. MANTZ
Colonel, QMC
Commanding

CONTENTS

	<u>Page</u>
List of figures and tables	vi
Abstract	x
Introduction	1
PART I. REVIEW OF THE ANALYTICAL AND EXPERIMENTAL DATA USED IN THE DESIGN OF THE PROTECTIVE COMBAT BOOT	1
A. Gross impulse input to the boot/foot system	2
B. Impulse per unit area input to the foot	5
C. Peak pressure input to the foot	5
D. Empirical parameter variation of material thickness and honeycomb crushing strength for a honeycomb shank system	11
PART II. DEVELOPMENT OF PROTOTYPES OF A DMS PROTECTIVE COMBAT BOOT	13
A. Boot outsole configurations	13
B. Protective shank concepts	13
1. Honeycomb density and crushing	13
2. Honeycomb layered system	25
3. Shank thickness and width	27
4. Metal heel counters	27
PART III. CRDL BLAST EVALUATION OF CON- CEPTS A,B,C,D, AND E	30
A. Test procedure	30
B. Damage to the cadaver specimens with protective concepts A,B,C,D and E	30
C. Damage to the boot and shank for concepts A,B, C,D, and E	47
D. Conclusion based on the blast evaluation of concepts A,B,D and E	48

CONTENTS (Continued)

	<u>Page</u>
PART IV. PRODUCTION OF DMS PROTECTIVE FOOTWEAR	60
A. Boot variables	60
B. Production methods	60
1. Molding cycle	62
2. Thermal cycle during curing	67
PART V. BLAST EVALUATION OF THE PRODUCTION TYPE DMS PROTECTIVE COMBAT BOOTS	69
A. Comparison between leather and metal heel counters	72
B. Comparison between outsole configurations	74
C. Comparison between the two-piece and one-piece shanks	74
D. Comparison between loading systems	74
PART VI. CONCLUSIONS AND RECOMMENDATIONS FOR PRODUCTION FOOTWEAR	75
PART VII. DRAWINGS, SPECIFICATIONS AND COST ESTIMATES	76
A. Drawings	76
B. Specifications for fabrication	77
C. Cost estimates	77
References	80
Appendices:	
A. Drawings	81
B. Specifications for the protective shank and boot fabrication	87
C. CRDL autopsy reports on damage to cadaver lower extremities	91

LIST OF FIGURES

	<u>Page</u>
1 Gross Impulse As A Function Of Ground Contact Area With A 112° Wedge	3
2 Protective DMS Combat Boot With Cutaway Heel	4
3 Protective Boot With Full Heel (Counter Pocket Undyed)	6
4 Estimated Gross Impulse Damage Threshold Relationship For An Impulsively Loaded Human Foot	8
5 Pressure-Impulse Damage Threshold Relationship For An Impulsively Loaded Human Foot	9
6 Aluminum Honeycomb Attenuator Test Configuration	10
7 End View Of Parameter Variation Test Configuration (Six Inches Long)	12
8 Artist's Conception Of Boot Outsole No. 1	14
9 Boot Outsole Configuration No. 1	15
10 Artist's Conception Of Boot Outsole No. 2	16
11 Boot Outsole Configuration No. 2	17
12 Artist's Conception Of Boot Outsole No. 3	18
13 Boot Outsole Configuration No. 3	19
14 Artist's Conception Of Boot Outsole No. 4	20
15 Boot Outsole Configuration No. 4	21
16 Artist's Conception Of Boot Outsole No. 5	22
17 Boot Outsole Configuration No. 5	23
18 Section View Of Concepts A, B, C, D and E Of Blast Protective Footwear	24
19 Characteristic Load Deflection Relationship For Aluminum Honeycomb In Axial Cell Compression (Idealized Depiction)	26

LIST OF FIGURES (Continued)

	<u>Page</u>
20 Concept C Blast Protective Footwear (Unbonded Metal Counter Shown In Center)	28
21 One Pair Of Metal Heel Counters	29
22 Concept A, Blast Protective Footwear	31
23 Concept B, Blast Protective Footwear	32
24 Anti-Personnel Land Mine U. S. Army M-14 APERS (Taken From TM9-1940)	33
25 CRDL Test Fixture For Blast Evaluation Of Protective Footwear	34
26 Concept D (On left) And Concept E Of Blast Protective Footwear	35
27 Landmine Induced Damage To A Standard Stitched Boot And A Standard DMS Boot With Resulting Foot Damage (Photographs From Biophysics Div., CRDL)	36
28 Bottom View Of Cadaver Lower Extremities Protected By Concepts A And B (Photographs Provided By CRDL)	38
29 Cadaver Lower Extremities Protected By Concept A Blast Protective Footwear (Photographs Provided By CRDL)	39
30 Cadaver Lower Extremities Protected By Concept B Blast Protective Footwear (Photographs Provided By CRDL)	40
31 Cadaver Lower Extremities Protected By Concept C Blast Protective Footwear (Photographs Provided By CRDL)	41
32 Cadaver Lower Extremities Protected By Concept D Blast Protective Footwear	42
33 Cadaver Lower Extremities Protected By Concept E Blast Protective Footwear (Bottom View)	43

LIST OF FIGURES (Continued)

	<u>Page</u>
34	44
Cadaver Lower Extremities Protected by Concept E Blast Protective Footwear (Side View)	
35	49
Section View Of Concepts A, B, C, D and E Of Blast Protective Footwear After Blast Loading (On Right)	
36	51
Boot Damage For Concepts A and B	
37	53
Boot Damage For Concepts C, D, and E	
38	55
Blast Protective Footwear After Exposure To An M-14 APERS Land Mine (Concepts A On Left And Concepts B On Right)	
39	56
Interior View Of Concept C After Blast Loading	
40	57
Section View Of Blast Protective Footwear Concepts A and B	
41	58
Section View Of Blast Protective Footwear Concept C	
42	61
Two Shank Types Evaluated In Production Type Prototypes	
43	63
C.I.C. Molding Machine	
44	64
Finish Machined Mold Sole Pistons	
45	65
Shanks Shown Laced In Place For Molding	
46	66
Emplacement Of Metal Counters	
47	68
Temperature Rise At Various Points In The Direct Molded Boot Outsole During Vulcanization	
48	70
Typical Examples Of Blast Loaded Specimens With Protective Boots With Leather Counters	
49	71
Typical Examples Of Blast Loaded Specimens With Protective Boots With Metal Counters	

LIST OF TABLES

		<u>Page</u>
1	Autopsy Damage Estimate For Human Lower Extremities Encased In IITRI Protective Footwear	45
2	OSG Damage Analysis Of Protected Lower Extremities Exposed To An M-14 Land Mine	46
3	Composite Autopsy Results Of CRDL Test Series	73

ABSTRACT

Several of the blast protective combat boot concepts which were developed under Phase I of this program were fabricated and proof-tested under Phase II. All of the protective boots incorporated a honeycomb filled shank. The high strength aluminum honeycomb filler ranged from 2550 psi to about 4200 psi nominal crushing strength.

In addition to the protective shank, several models of protective boots were fabricated with wedge-shaped heel cut outs and/or metal heel counters. A total of 150 pairs of protective boots were fabricated with eight possible combinations of the variables studied.

Sixty-four cadaver specimens protected by various types of boots were blast-loaded with the M-14 land mine. 27% of the protective boots with conventional counters resulted in a foot damage level which could possibly be "salvaged from amputation" while 63% of the protective boots incorporating a metal heel counter were "possible salvages." This compares to a zero percent rate of possible salvage with conventional footwear.

RESEARCH AND DEVELOPMENT OF BLAST-PROTECTIVE FOOTWEAR, FABRICATION AND PROOFTESTING

Introduction

The development of a protective combat boot for use against antipersonnel (AP) land mines is part of the overall effort to increase the effectiveness of U. S. ground combat forces engaged in conventional type warfare. This research was originally a government study based primarily on data from World War II and the Korean conflict.

Studies conducted by the U. S. Army Natick Laboratories, Natick, Mass., and the Chemical Research Development Laboratories (CRDL),* Edgewood Arsenal, Maryland, (Holmes, 1960, and Stewart, 1962), based on the original concept by Dr. Stephen J. Kennedy and Mr. Edward R. Barron, indicated the feasibility of reducing the damage induced by AP land mines and an IIT Research Institute Research Program was initiated in July of 1962; Phase I of the program included the analytical and experimental portion of the "Research and Development of Blast Protective Footwear", (Fujinaka, April 1964). Phase II covers the fabrication and prooftesting of blast-protective combat boot prototypes.

In reviewing the test data set forth in later sections of this report, it should be realized that the objectives of this program were quite limited. The limitations are discussed in the Phase I Report, but briefly stated, the primary objective was to develop a useful protective combat boot which would not seriously reduce mobility or otherwise impair the functional characteristics of the standard combat boot. Thus, severe restrictions on weight and sole thickness were imposed. As a result of these design limitations, it was not possible to reduce the number of cases which result in amputation of the foot.

The damage criteria for a "possible salvage" from amputation was based on a medical judgment from an experienced observer. In some cases, a number of observers evaluated the same injury and an average judgment was developed. All of the injuries evaluated in this report were the result of the blast exposure of cadaver lower extremities. The blast loading was generated by U. S. Army M-14 Anti-Personnel mines which contain approximately one ounce of tetryl explosive.

PART I. REVIEW OF THE ANALYTICAL AND EXPERIMENTAL DATA USED IN THE DESIGN OF THE PROTECTIVE COMBAT BOOT

Numerous sources of design information were used for the development of the various protective boot systems which were fabricated during Phase II of this program. The Phase I report (Fujinaka, April 1964) was the primary source of design information; however, the IITRI reports for the Office of the Surgeon General (MacDonald, February 4, 1964, and Fujinaka, December 15, 1964) were used for the relationship of pressure and impulse to damage level. The CRDL report (Stewart, 1962) was used to provide additional empirical data on the effectiveness of several types of protective shanks which were later studied during Phase I of this program.

*Now Defense Development and Engineering Laboratories.

several types of protective shanks which were later studied during Phase I of this program.

In the following review of the Phase I and other analytical and experimental data, no attempt will be made to summarize each of the reports indicated above; instead, the data is presented in a sequence which is logical to the designer rather than in any actual chronology.

A. Gross impulse input to the boot/foot system

There are three basic parameters which characterize the impulsive load generated by the land mine, peak pressure, peak impulse per unit area, and gross impulse. The latter is perhaps the most important in that the only practical technique for limiting the gross impulse is the shaping of the outsole of the boot. The peak pressure can be reduced by impedance mismatch techniques coupled with crushable materials, and the peak impulse per unit area can be reduced by means of a relatively stiff shank of large area. These three factors are all interrelated, of course, but it is the reduction in the gross impulse which is the first line of defense.

During Phase I, a number of experiments were conducted in order to determine the best method for minimizing the gross impulse input to the system. It was found that a simple wedge-shaped outsole with an included angle of 112 degrees would reduce the gross impulse by 36 percent compared to a flat bottomed steel surface. The projected area exposed to the mine was 3 x 6 inches in all cases discussed here. The flat bottomed steel shape received 20.8 pound seconds of gross impulse compared to 13.3 pound seconds for the 112-degree included angle wedge.

The flat bottomed steel shape spaced at one inch above the mine received about the same gross impulse as the 112-degree wedge in contact with the mine. Other considerations make the wedge shape more desirable than the flat surface spaced at one inch. These include (1) volume to incorporate an impedance mismatch shank for peak pressure reduction and (2) better distribution of impulse over the plantar areas of the foot.

Since the 112-degree wedge alone is not suitable as an outsole shape, a series of experiments was conducted in order to evaluate various three-dimensional rubber-steel configurations which could be used as a basis for a practical outsole design. Figure 1 shows the 112-degree included angle wedge with some neoprene rubber wedges located to simulate a configuration which can provide some lateral support for the boot outsole. Note that full length rubber wedges which are six inches long result in about 17.7 pound seconds of gross impulse while the elimination of the rubber ($L = 0$) results in the 13.3 pound seconds of impulse associated with a bare 112-degree wedge. As the length, L , of the rubber wedges is increased, it is apparent that the impulse increases. For $L = 1.0$ inches, however, the increase is very slight and this led directly to the outsole

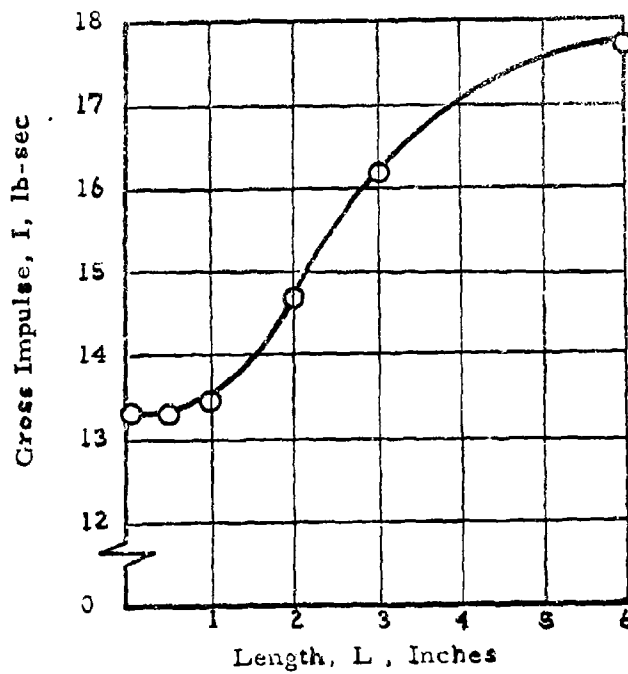
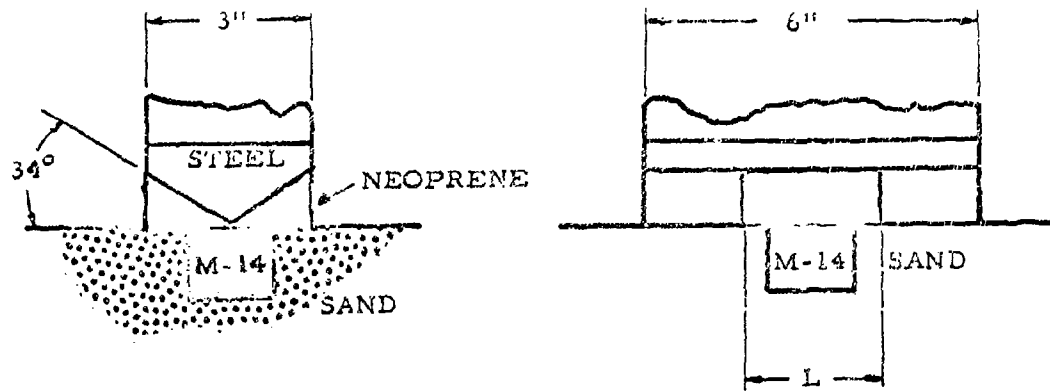

Figure 1 GROSS IMPULSE AS A FUNCTION OF GROUND CONTACT AREA WITH A 112° WEDGE

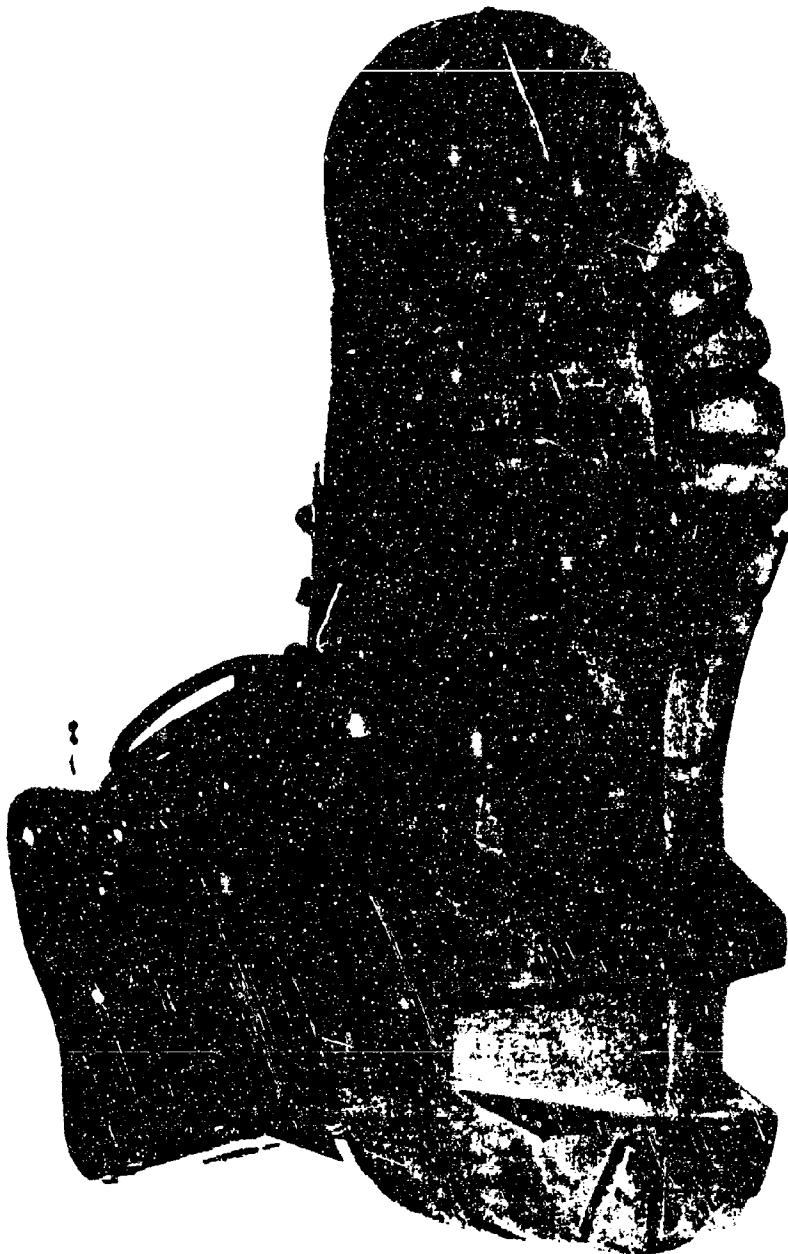

FIGURE 2 PROTECTIVE DMS COMBAT BOOT WITH CUTAWAY HEEL

shape shown in Figure 2 and IITRI drawing 2856000 (see Appendix A).

An alternate outsole shape with a more conventional heel is shown in Figure 3 and IITRI drawing 2856001 (see Appendix A). This second outsole configuration represents a back-up system which should only be used in the event of some serious functional defect which may be uncovered during extensive field evaluation of the outsole with a "cutaway heel" as shown in Figure 2. Besides reducing the gross impulse, the Figure 2 outsole will reduce the overall weight of each boot by approximately 1.5 ounces when compared to the outsole pictured in Figure 3.

It might be noted that the gross impulse into the foot may be slightly less than that into the boot. This is due to residual momentum "trapped" within the various parts of the boot and perhaps carried out of the system in the form of particles of rubber ejected at high velocity.

B. Impulse per unit area input to the foot

The distribution of the gross impulse over the area receiving the loading has never been studied in detail. However, it is obvious that the distribution is not uniform over the bottom surface of the boot. This being the case, techniques for providing uniform distribution of the impulse over the plantar area of the foot are considered to be of some importance although secondary to the reduction of gross impulse and peak pressure. A protective shank which is as wide and as long as practical was concluded to be the most effective. In addition, stiffness in bending was also considered to be a desirable characteristic. This latter consideration would also permit the use of the lowest possible crushing strength in the honeycomb layer which could also serve to limit the long duration peak transmitted stress.

C. Peak pressure input to the foot

With a given impulse per unit area, the damage to a given structure can generally be minimized by minimizing the peak pressure. Minimizing the peak pressure is in turn generally associated with increasing the time duration of the pressure pulse.

The M-14 land mine has been shown to generate a peak pressure of approximately 40.4 kilobars (594,000 psi) in the plastic surface of the land mine. This high amplitude pressure pulse is characterized by an abrupt rise to the peak pressure and an approximately linear decay to a relatively low pressure within about 3.5 microseconds. (Fujinaka, April 1964). If such a shock wave impinges on a high impedance material such as aluminum, the peak pressure will increase to approximately 71 kilobars (1,030,000 psi) and the impulse applied to a small area of the aluminum surface will be approximately 1.8 psi-seconds during the first few microseconds. The total impulse per unit area will be considerably larger if a longer time

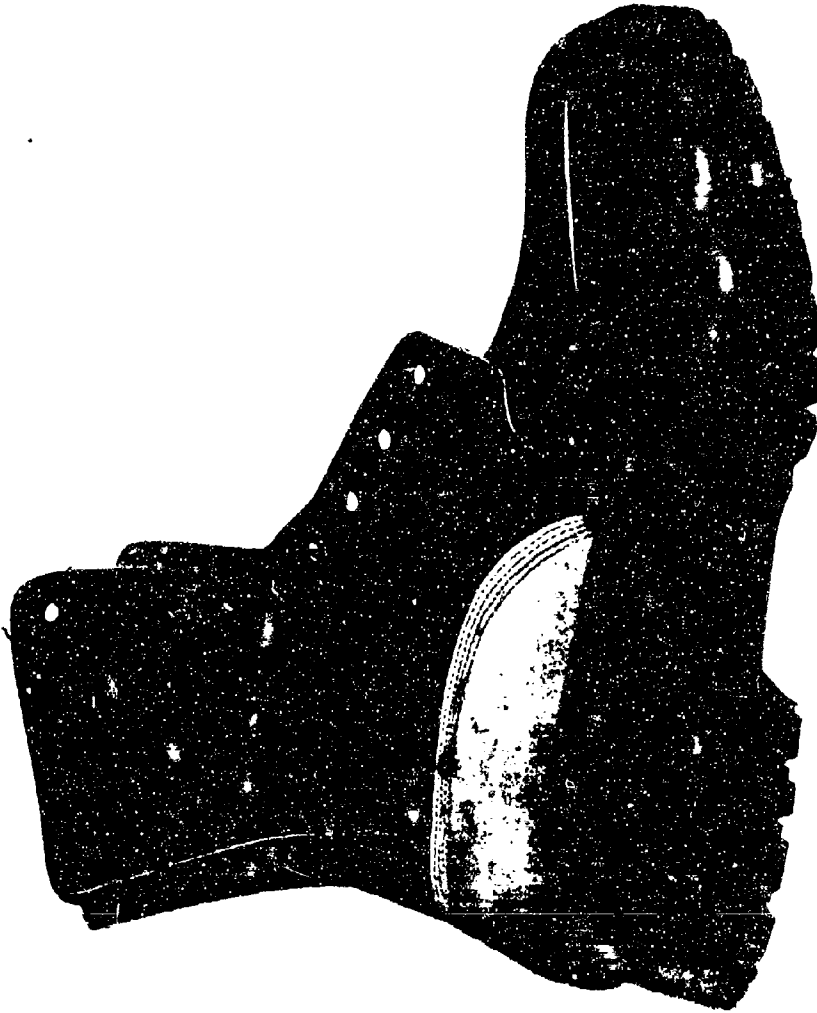

6 1 2 3 4 5 6

Figure 3 PROTECTIVE BOOT WITH FULL HEEL
(Counter Pocket Undyed)

interval is considered. This is due to a "gas expansion" phase of the explosive loading. Although the total impulse per unit area has never been explicitly measured, an estimate of perhaps 3 or 4 psi-seconds appears to be reasonable. These figures refer to a flat surface in contact with the land mine.

Even at values for impulse per unit area of, say, 1.0 psi-seconds it has been shown that a cadaver human foot can only tolerate a peak pressure of about 3,000 psi before the amputation level is reached (Fujinaka, December 1964). This is graphically shown in Figures 4 and 5 which relate the amputation level of damage to peak pressure and to gross impulse and unit area impulse, respectively. All of these data indicate why the peak pressures on the order of hundreds of thousands of psi cannot be tolerated at the expected impulse levels generated by the M-14 land mine.

Thus, the importance of reducing the peak pressure by perhaps two orders of magnitude can be clearly seen. Even a one order of magnitude reduction would not be sufficient to prevent amputation in any significant number of cases.

The Phase I results indicate that a layered system of materials can theoretically reduce the initial shock pressure by at least two orders of magnitude. A one dimensional system containing a layer of high strength aluminum honeycomb (approximately 4200 psi crushing strength) can theoretically reduce the peak pressure input to the foot to 3950 psi with the system shown in Figure 6. This theoretical calculation does not require the use of the crushing characteristics of the honeycomb but does assume that the honeycomb can be treated as a low impedance layer of material which is of relatively low gross density with a relatively high shock propagation velocity. This treatment is theoretically valid if the honeycomb cell size is small enough. In addition, elementary theory which would be applicable to long duration phenomena indicates that the long duration peak transmitted pressure can be limited to the crushing strength of the honeycomb.

Experiments conducted with a water bath replacing the foot tend to indicate that the transmitted peak shock stresses can be held to less than one kilobar (14,200 psi) with such a system and the indications obtained from a tourmaline pressure gage measurement indicate that the peak pressure may be as low as 3180 psi.

A variety of other protective shanks fabricated into boots indicated that a solid cast aluminum shank would transmit approximately one kilobar (14,200 psi) peak pressure to water while a hollow stainless steel sheet metal shank can be expected to transmit 3.8 to 4.2 kilobars peak pressure depending upon shank width. These two types of shanks have been shown to be of some value in reducing the amputation rate (Stewart, 1962), and it is likely that a wedge shaped version of the aluminum

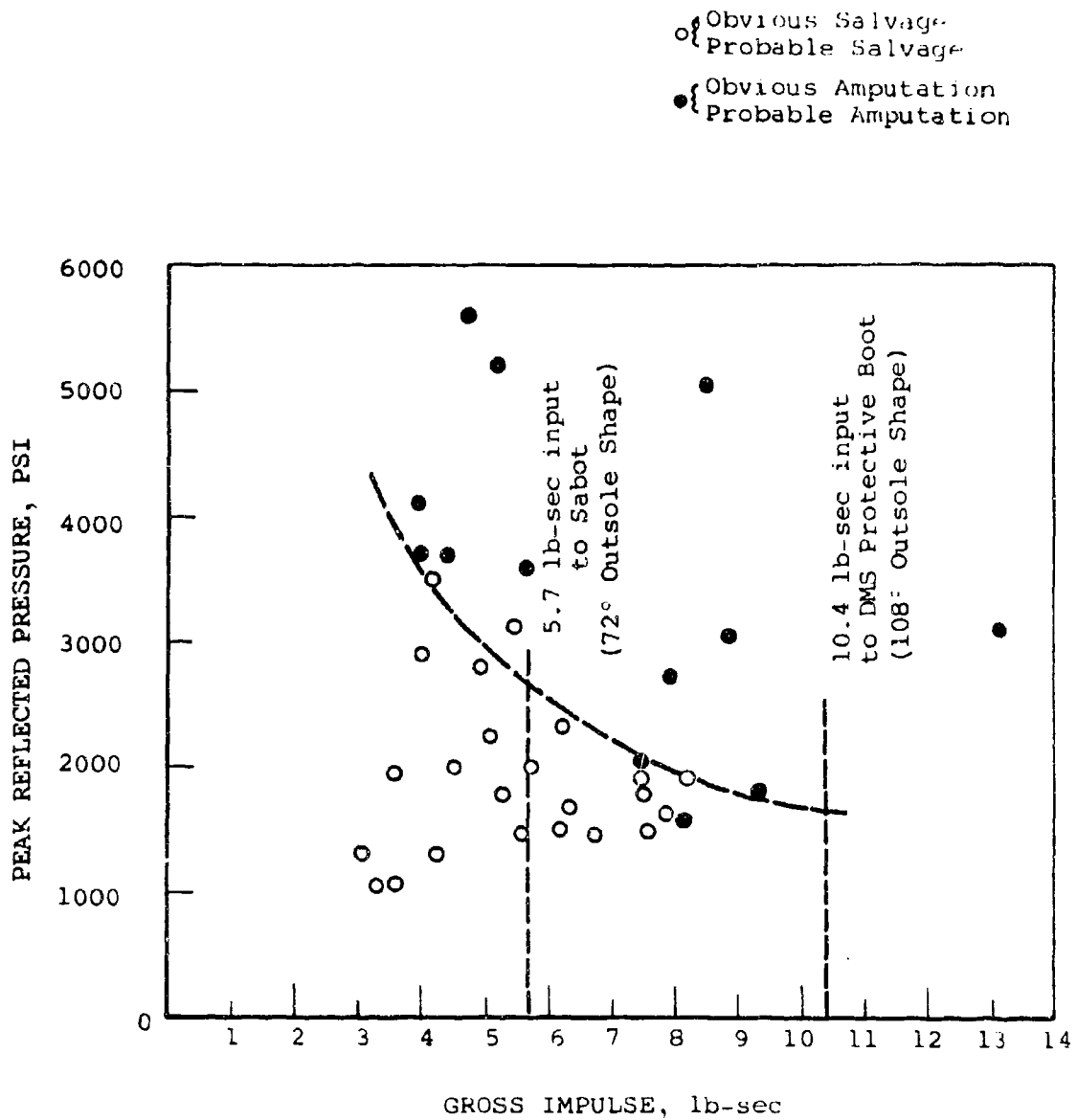

Figure 4 ESTIMATED GROSS IMPULSE DAMAGE THRESHOLD RELATIONSHIP FOR AN IMPULSIVELY LOADED HUMAN FOOT

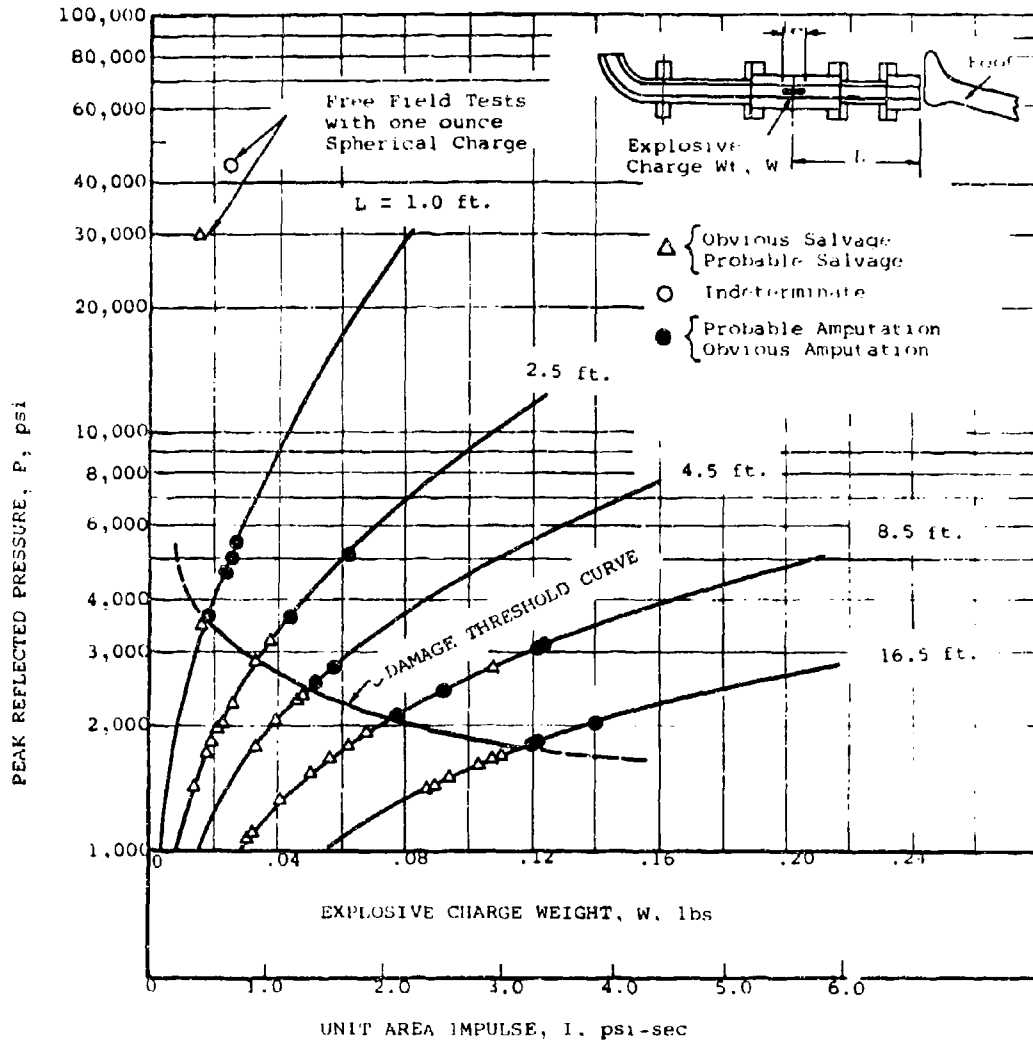

Figure 5 PRESSURE-IMPULSE DAMAGE THRESHOLD RELATIONSHIP FOR AN IMPULSIVELY LOADED HUMAN FOOT

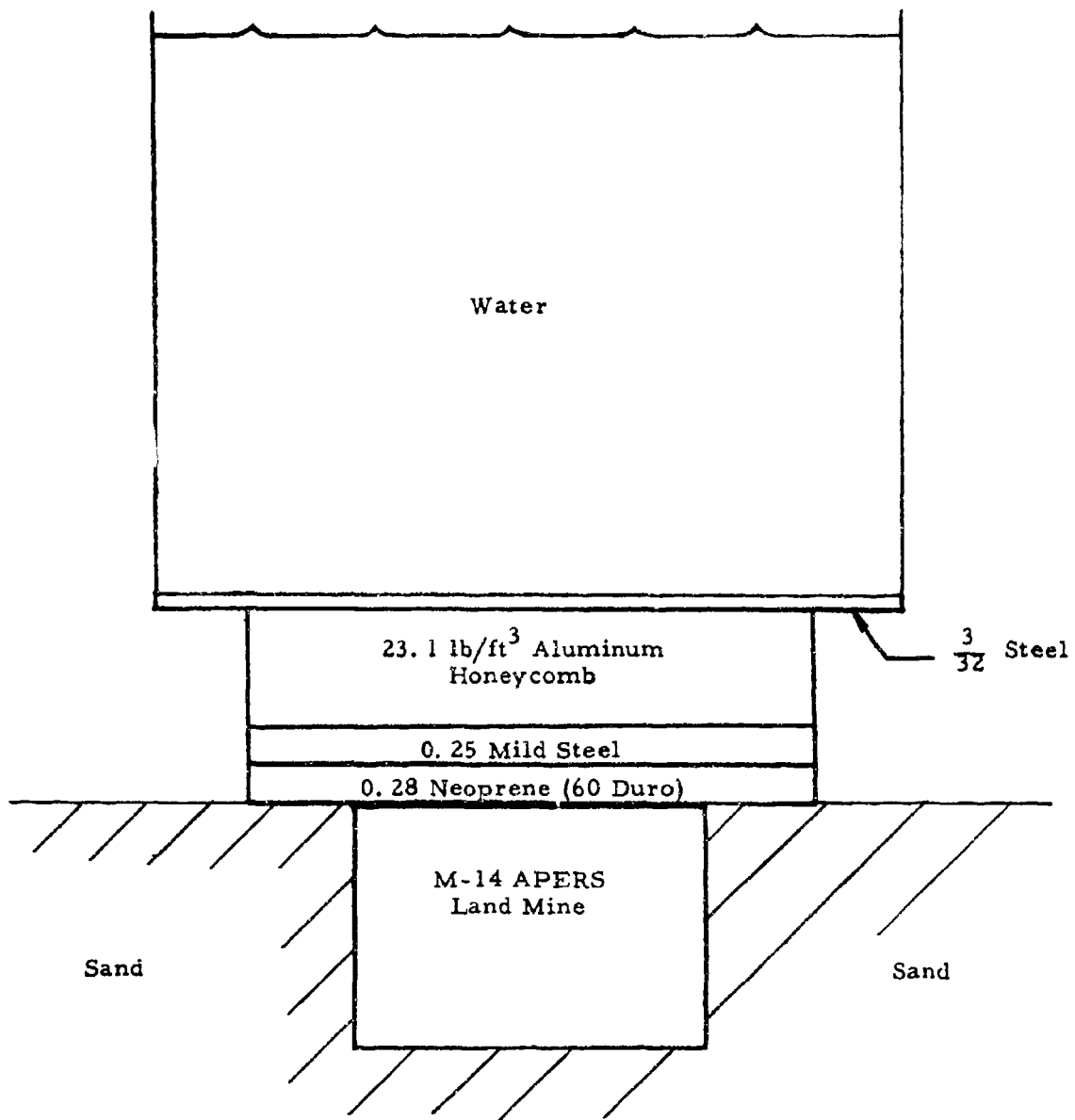

Figure 6 ALUMINUM HONEYCOMB ATTENUATOR TEST CONFIGURATION

honeycomb system described above would be even more successful.

D. Empirical parameter variation of material thickness and honeycomb crushing strength for a honeycomb shank system

Based upon the Phase I conclusion that an aluminum honeycomb system of impedance mismatched materials would provide the most suitable configuration for a protective shank, a parameter variation study was conducted in order to determine the required metal layer thickness and honeycomb densities. Minimum thickness and weight were the primary consideration. A variety of aluminum honeycomb shank concepts was evaluated and the basic system shown in Figure 7 was subjected to an extensive parameter variation study.

Figure 7 shows a cross-section of a six-inch long shank which has an outsole wedge shape incorporating the 112-degree included angle for minimum gross impulse. A 3 x 6 x 12 inch neoprene block was used to approximately simulate the human foot. Four of the six items (numbered in Figure 7) were variable: the aluminum honeycomb used in items 2 and 4 was 1/8 inch nominal cell size and fabricated from 5052-H39 aluminum alloy in all cases, but the foil thickness was selected for three different crushing strength levels as indicated below.

Hexcel Part No.	Al-1/8-5052 -0.006	Al-1/8-5052 -0.004	Al-1/8-5052 -0.003
Foil Thickness, in.	0.006	0.004	0.003
Gross Density, lb/ft ³	23	15.5	11.3
Crush Strength, psi	4150	2250	1650

The two stainless steel sheet layers, items 3 and 5 were each fabricated in three material thicknesses: 1/8 inch, 1/16 inch, and 1/64 inch.

Based primarily on the assumption that at least one of the honeycomb layers should not crush to solid (beyond 70 percent deformation) only the two high strength honeycomb materials and only the two thicker materials were considered for a final shank design.

In general, the heavier the sheet metal bottom layer the less the honeycomb would crush. Practical considerations limit the thickness of the sheet metal layer since this represents a major portion of the weight of the protective shank. Thus, the final shank design must attempt to combine the thinnest possible sheet metal with the lowest density honeycomb which does not crush to solid.

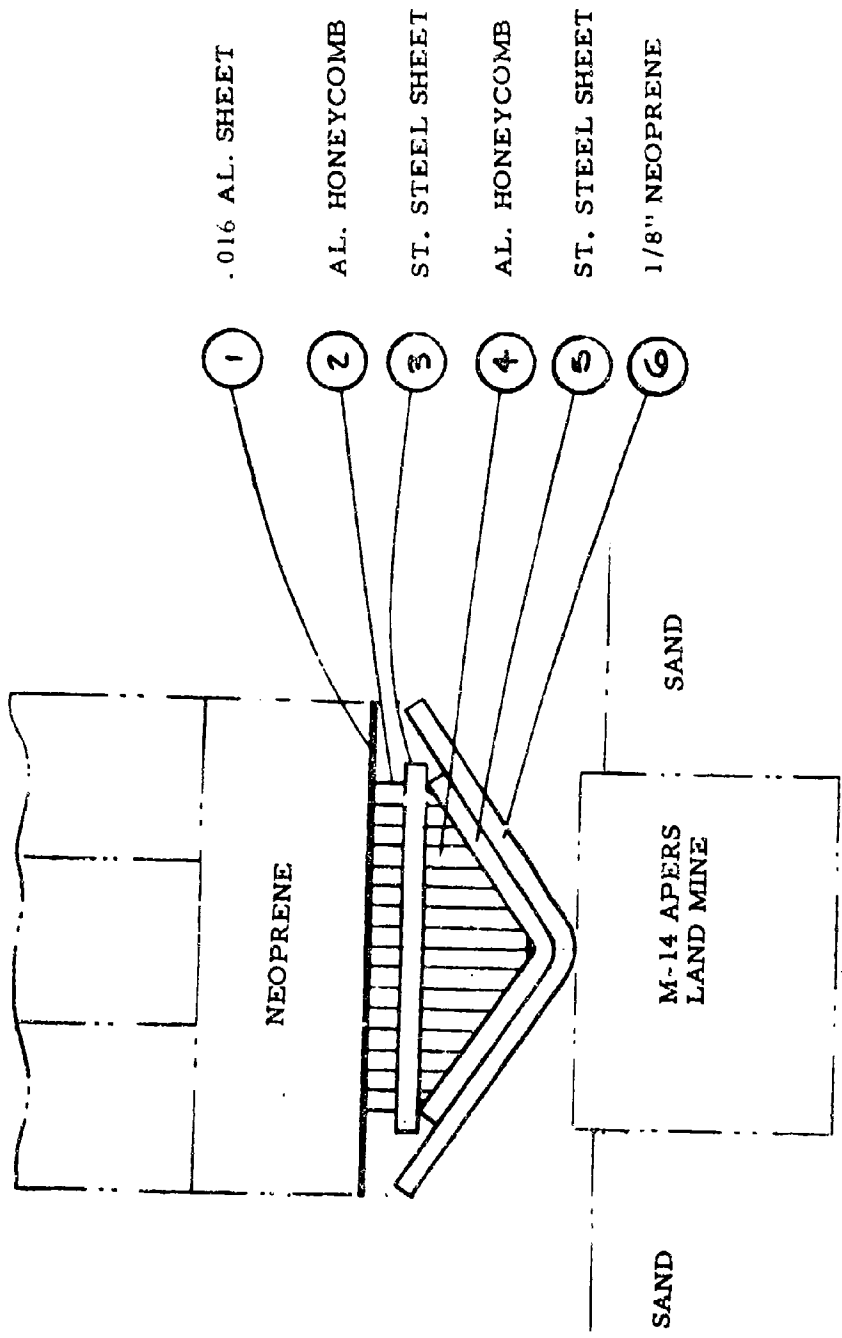

Figure 7 END VIEW OF PARAMETER VARIATION TEST CONFIGURATION
(Six Inches Long)

PART II. DEVELOPMENT OF PROTOTYPES OF A DMS PROTECTIVE COMBAT BOOT

The principles outlined in the preceding section were applied to the design of various DMS protective combat boot systems. All of the protective shanks employed the high strength aluminum honeycomb system coupled with a relatively high impedance wedge shaped stainless steel outer layer. The boot rubber outsole generally had a similar wedge shape with concessions to the stability requirements for walking and standing. Minimum weight and thickness were considered to be of primary importance but compatibility with currently available fabrication techniques for Direct Molded Sole footwear was also an important factor.

A. Boot outsole configurations

The five outsole configurations indicated in Figures 8 through 17 were designed with the intent of minimizing the gross impulse input to the system while still maintaining a base for lateral stability. Outsole No. 1, No. 3, and No. 2 were considered to be the best overall designs in that order based on a number of considerations including ease of fabrication, comfort, and clogging resistance.

B. Protective shank concepts

Based on the analytical and experimental data of Phase I of this program, a family of experimental protective shank concepts was developed. Figure 18 indicates a cross-section through the various shanks and protective systems which were fabricated for preliminary blast evaluation. The first series of experiments evaluated several variables including honeycomb density (crushing strength), metal heel cup (Concepts C and D), shank width, shank thickness, layered construction (single or double), and outer metal wedge plate construction.

1. Honeycomb density and crushing strength

The aluminum honeycomb used in the Concept A through E protective shanks ranged from 15.3 lb/ft³ to 23.1 lb/ft³ density. This material was fabricated by pre-corrugating 5052-H39 aluminum foil into a configuration which resulted in a hexagonal cell structure with a 1/8 inch nominal cell size. The static crushing strength of the honeycomb material in axial cell compression is approximately proportional to the gross density of the honeycomb and ranges from 4150 psi for the 23.1 lb/ft³ density to 2550 psi for the 15.3 lb/ft³ gross density. The 11.3 lb/ft³ honeycomb which was evaluated during the Parameter Variation Study of Phase I (see Section II-D) was not strong enough to be considered further. The three honeycomb materials with the Hexcel part numbers are tabulated below:

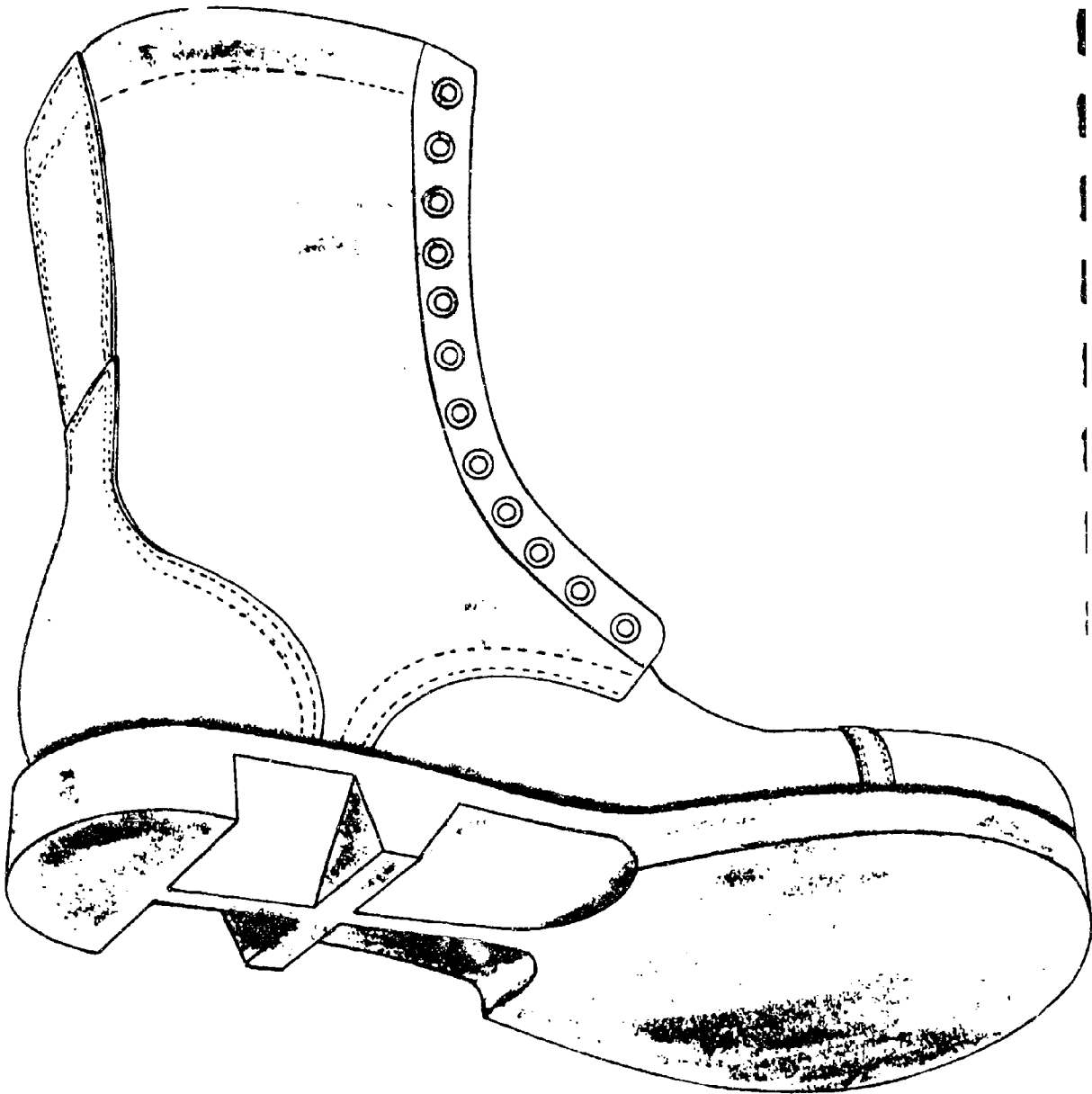
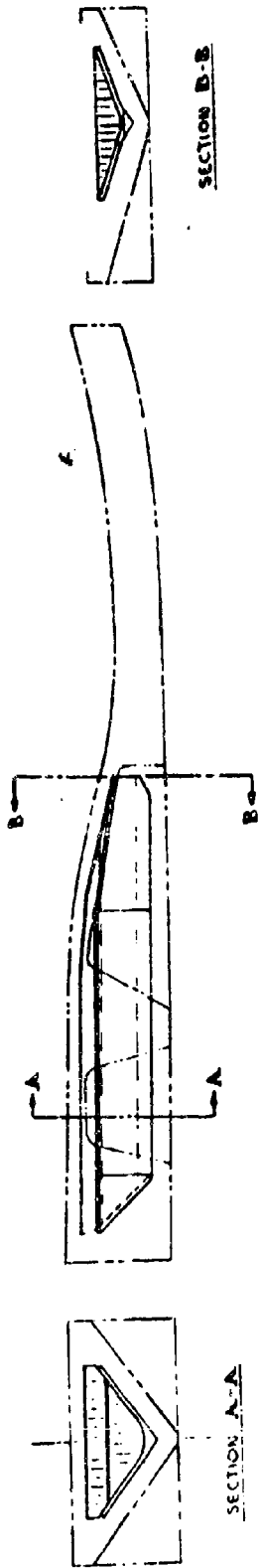

Figure 8 ARTIST'S CONCEPTION OF BOOT OUTSOLE NO. 1



15

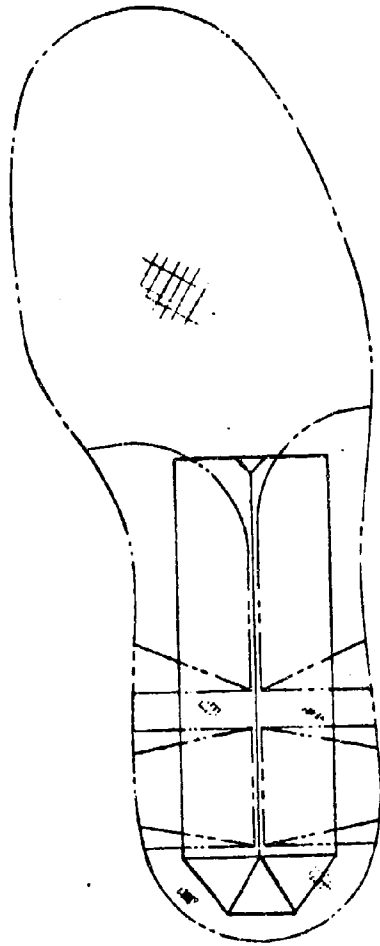

Figure 9 BOOT OUTSOLE CONFIGURATION NO. 1



Figure 10 ARTIST'S CONCEPTION OF BOOT OUTSOLE NO. 2

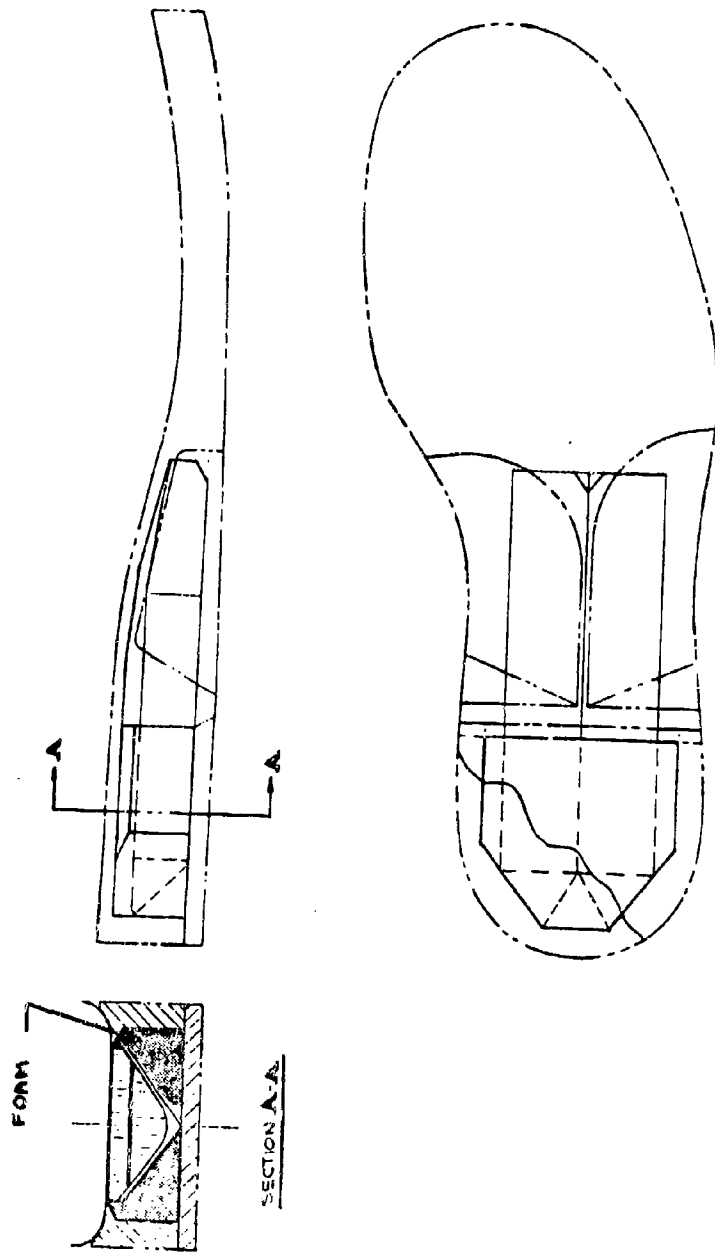

Figure 11 BOOT OUTSOLE CONFIGURATION NO. 2

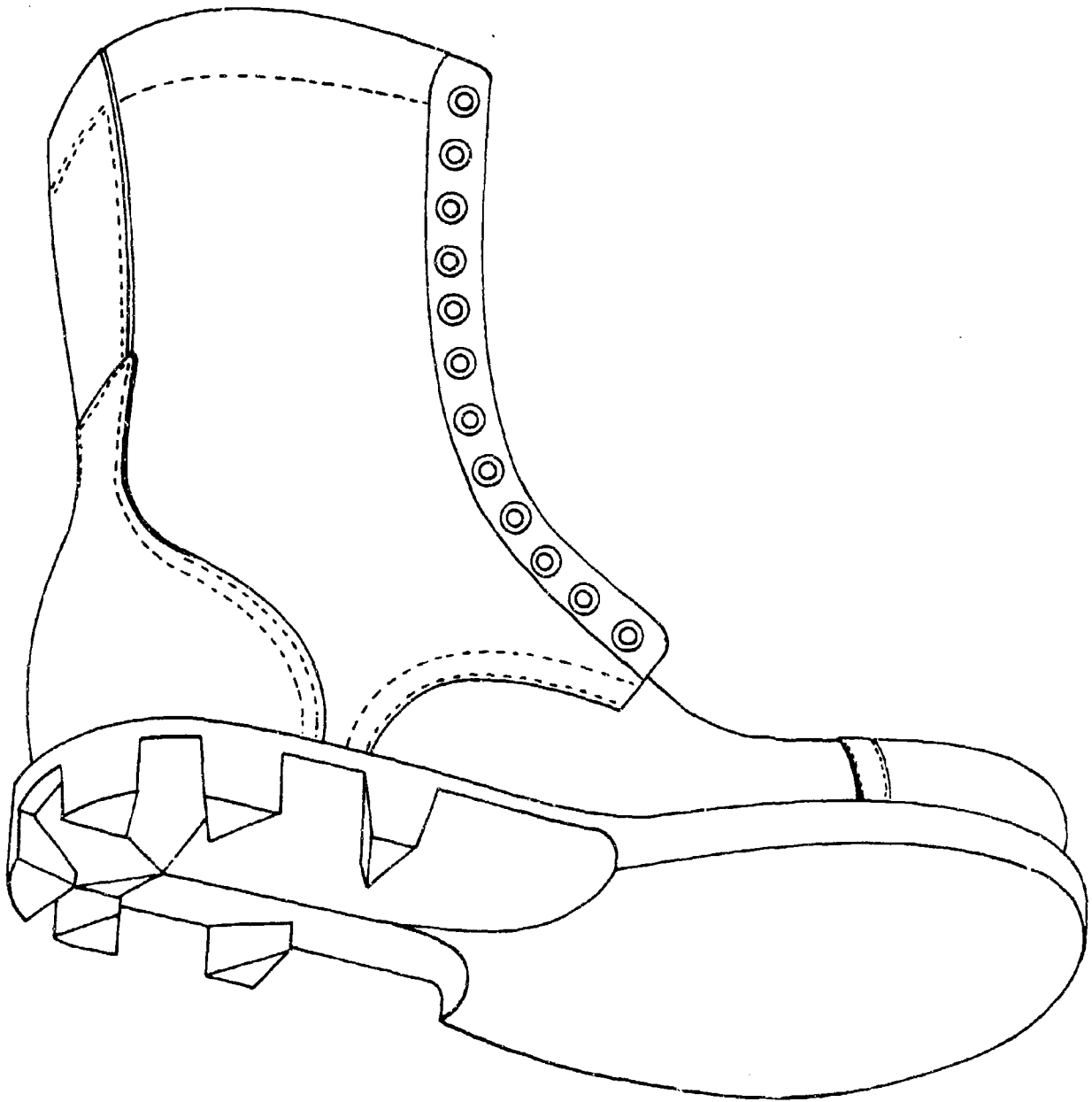

Figure 12 ARTIST'S CONCEPTION OF BOOT OUTSOLE NO. 3

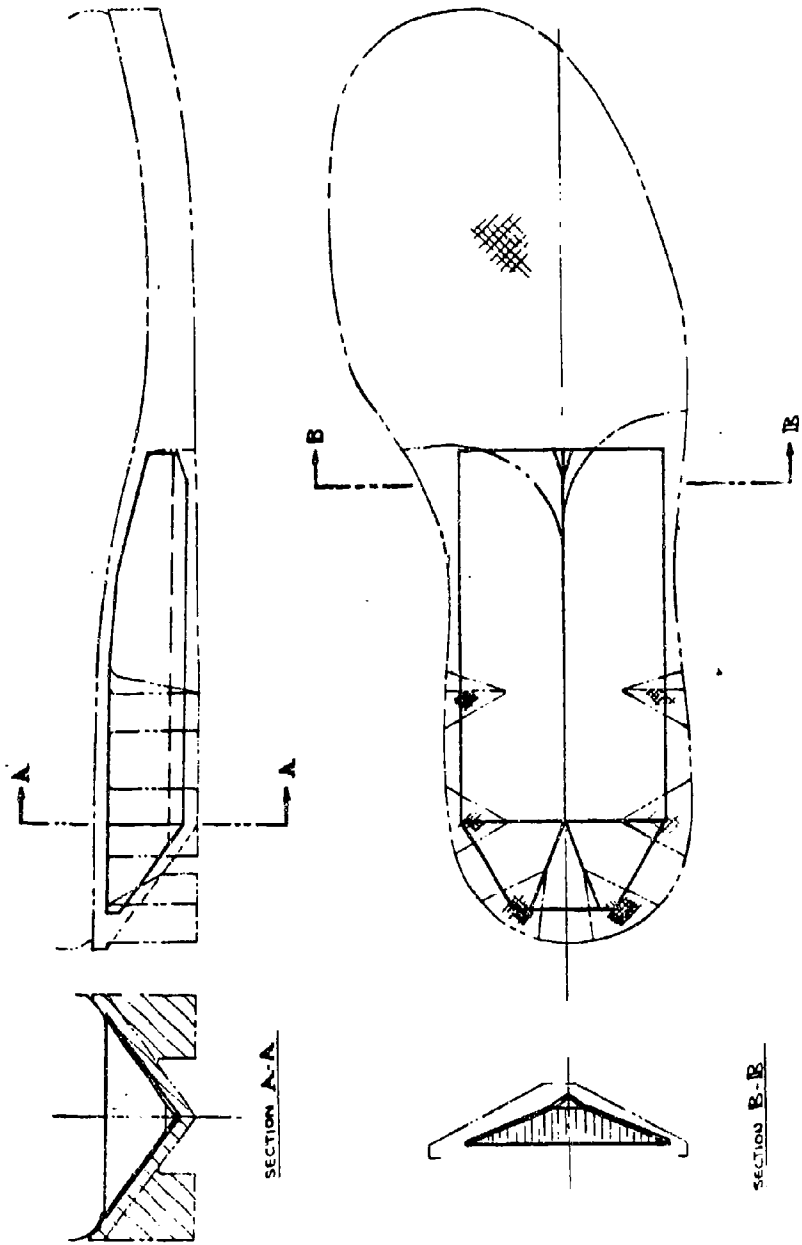

Figure 13 BOOT OUTSOLE CONFIGURATION NO. 3



Figure 14 ARTIST'S CONCEPTION OF BOOT OUTSOLE NO. 4

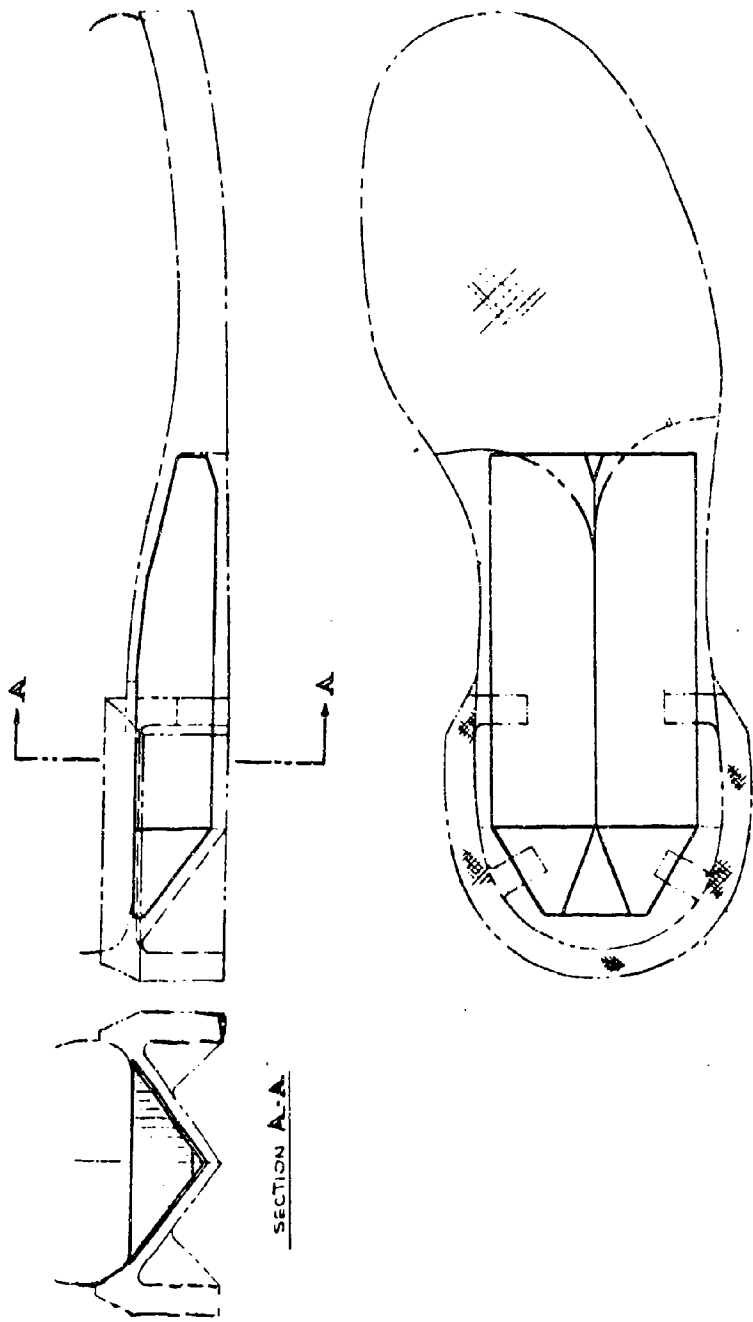
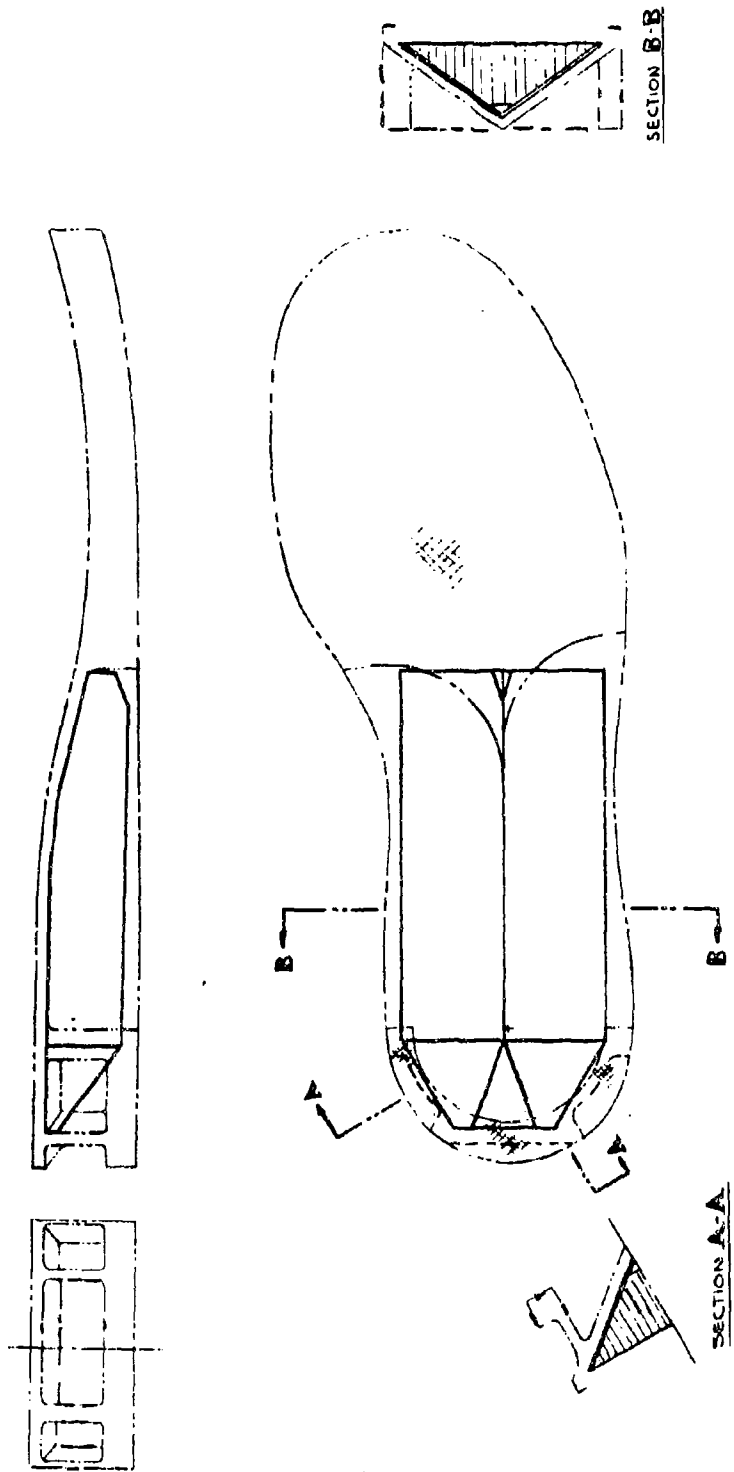

Figure 15 BOOT OUTSOLE CONFIGURATION NO. 4



Figure 16 ARTIST'S CONCEPTION OF BOOT OUTSOLE NO. 5



23

Figure 17 BOOT OUTSOLE CONFIGURATION NO. 5

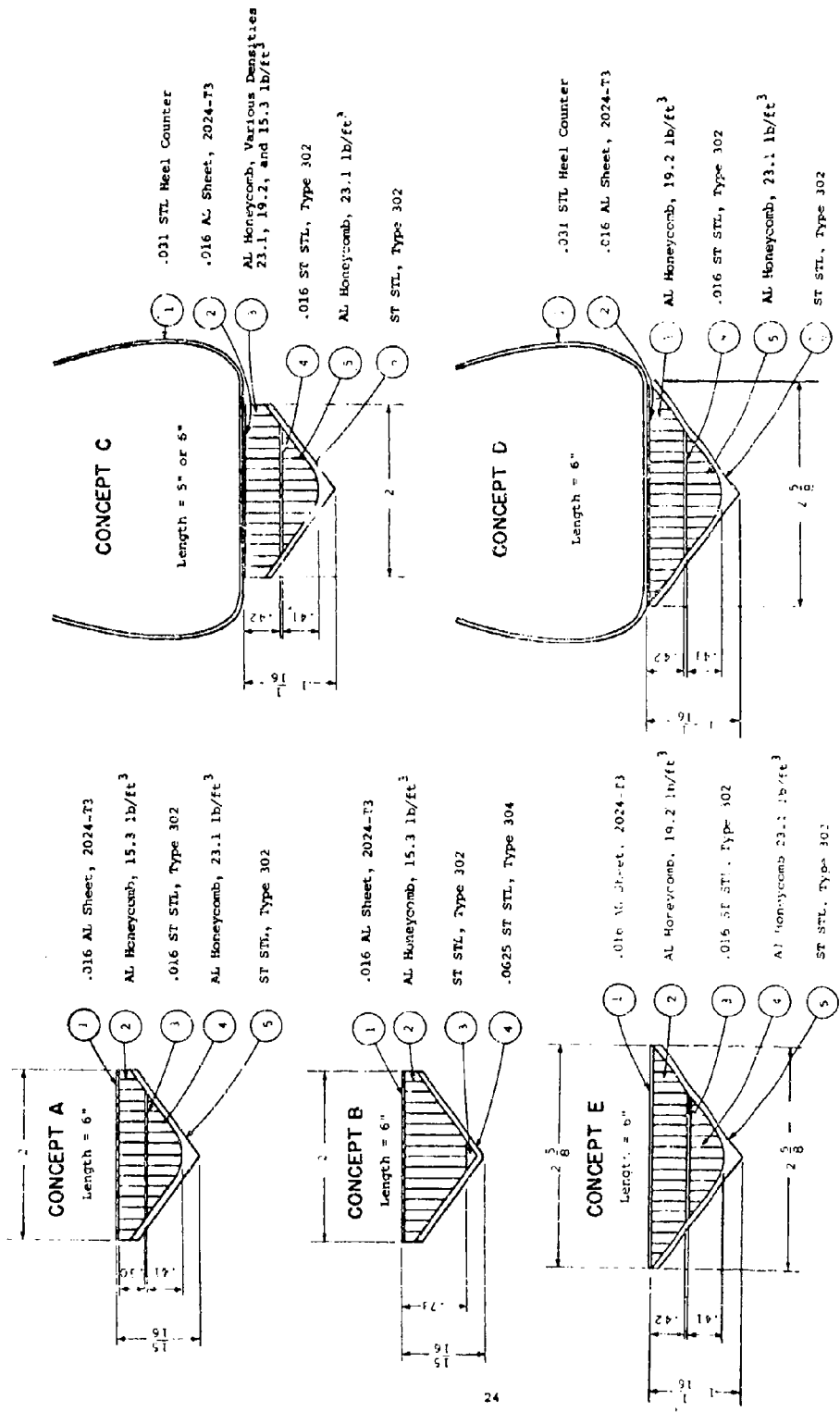

Figure 18 SECTION VIEW OF CONCEPTS A, B, C, D and E OF BLAST PROTECTIVE FOOTWEAR

Hexcel Part No.	Nominal Gross Gross, lb/ft ³	Nominal Crushing Strength, psi
1/8-5052-.006	23.1	4150
1/8-5052-.005	19.2	3320
1/8-5052-.004	15.3	2250

The last three digits in the Hexcel Part Number refer to the thickness of the aluminum foil in mils, which is corrugated into the final hexagonal configuration.

The honeycomb gross density is a value which includes the volume of the air contained within the cells and the mass of the adhesive which bonds the cell nodes together as well as the aluminum foil. In some cases, the variation in adhesive used at the cell nodes can result in relatively large variation in gross density. The 1/8-5052-.006 material has been received with a gross density of less than 20 lb/ft³ in some cases, but the crushing strength has been maintained.

Figure 19 indicates the typical load deflection relationship for the honeycomb material. Note that there is what might be termed an initial "overshoot" in the load followed by a continuing plastic deformation at a relatively constant load and finally a rise in load as the crushing deformation proceeds beyond the 70 percent level. The high loads transmitted as the material crushes beyond 70 percent and approaches solid aluminum is to be avoided as both theory and empirical results indicate.

Figure 18 also shows the results of blast loading the various protective shank systems with the M-14 land mine. Cadaver human feet were used during these experiments. (Details of the test procedure are presented in Section III-A). Note that the honeycomb material crashed to "solid" in several of the cases shown. This is particularly noticeable in the upper layer of Concept A, the single layer of Concept B, and the bottom layers of Concepts D and E. The crushing of the various honeycomb layers is discussed in greater detail in Part III.

2. Honeycomb layered system

The honeycomb concept was incorporated into the shank design in two basic forms: the single layer construction shown in Concept B of Figure 18 and the double layer construction shown in Concepts A,C,D and E of Figure 18.

The single layer construction is considerably lower in cost overall, but the two-layer construction is theoretically superior in minimizing the transmission of sub-microsecond disturbances and in permitting the use of two crushing strength

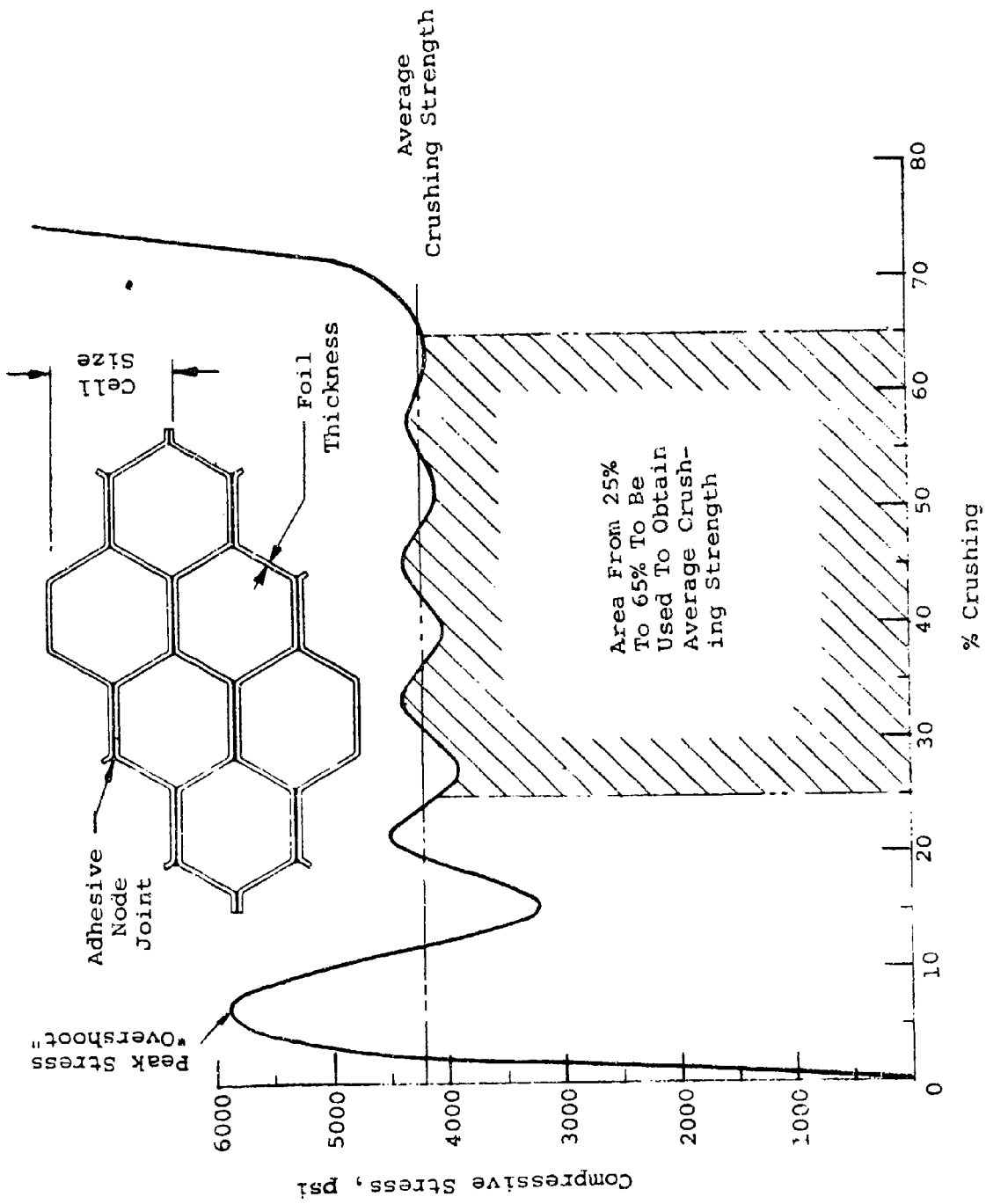

Figure 19 CHARACTERISTIC LOAD DEFLECTION RELATIONSHIP FOR ALUMINUM HONEYCOMB IN AXIAL CELL COMPRESSION (Idealized depiction)

levels. The latter is considered to be of most importance for this application.

The five concepts shown in Figure 18 were evaluated experimentally and the results are detailed in Part III. In addition, the one-layer and two-layer concepts were directly compared in another series of CRDL Blast Experiments with production type footwear.

3. Shank thickness and width

Figure 18 indicates an overall shank thickness of either 15/16 inch or 1-1/16 inch for Concepts A through E. The final configuration incorporated into the production type combat boots had a nominal one (1) inch thickness. The shank concepts shown in Figure 19 were studied in two overall lengths, five (5) inches and six (6) inches. The final configuration used in the size nine (9) production type footwear was nominally 5.5 inches in overall length (excluding sheet metal cover). Thus, over the course of the Phase II portion of this program several shank widths and lengths were evaluated. Details of the test results are included in later sections of the report.

4. Metal heel counters

Early in the blast evaluation of the protective shank concepts, the examination of the foot and boot mode of failure indicated that reinforcing of the boot upper could have a large influence on the damage level. The first attempt at verification of this theory involved the use of the relatively large mild steel sheet metal heel counters shown in Figure 20. This heel counter weighs about 7.2 ounces and was incorporated in both Concept C and D as shown in Figure 18. This metal counter is a welded up construction of 1/32 inch thick mild steel.

Subsequent to the testing of Concepts C and D, a smaller version of the metal heel counter was designed and fabricated for inclusion into a combat boot production prototype. Figure 21 shows the small metal heel counter which can be fitted directly in place of the conventional leather counter. The two-piece welded construction used for this counter could be replaced by a one-piece drawn form in large production. The weight of each of these counters is 3.15 ounces; however, the weight added to the boot is only 2.29 ounces since the leather conventional counter which it replaces weighs approximately 0.86 ounces. The results of the counter experiments are also discussed in later sections of this report.

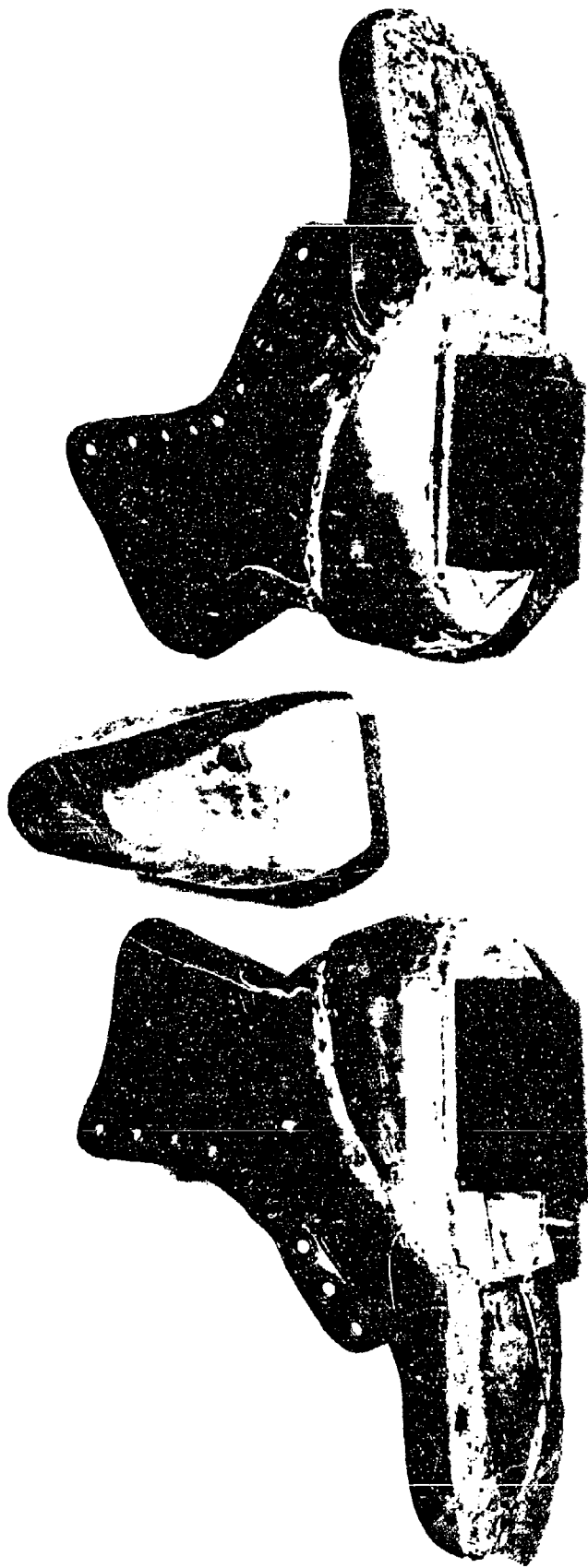

CONCEPT C BLAST PROTECTIVE FOOTWEAR
(Unbonded Metal Counter Shown in Center)

Figure 20

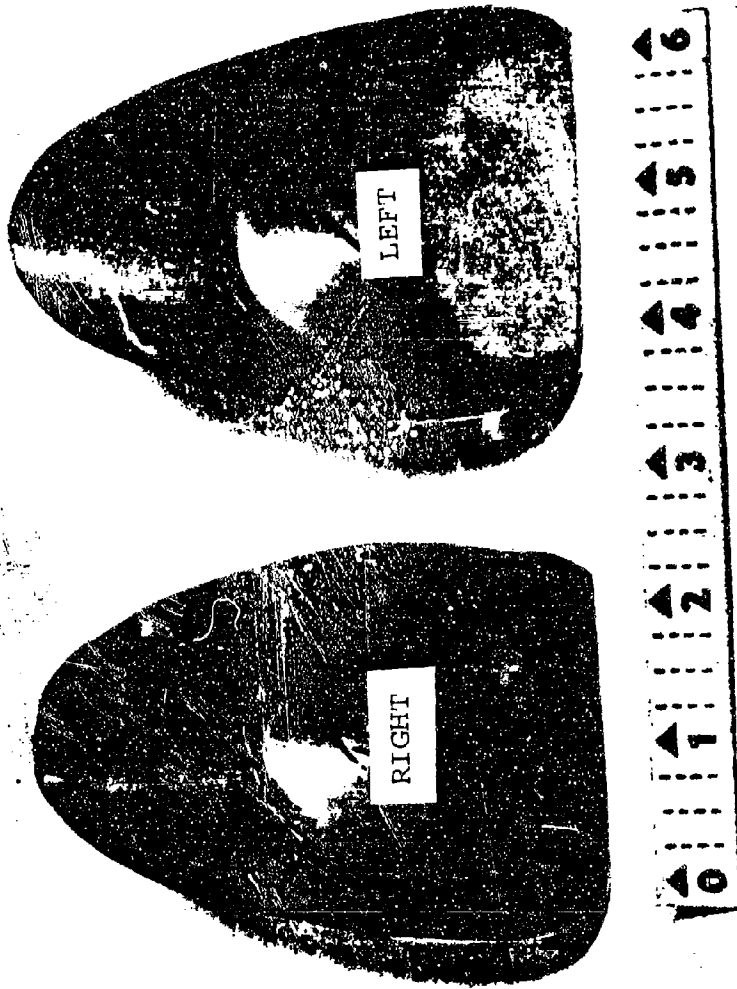

Figure 21 ONE PAIR OF METAL HEEL COUNTERS

PART III. CRDL BLAST EVALUATION OF CONCEPTS A,B,C,D and E

The protective boot concepts shown in Figure 18 were fabricated into footwear for blast evaluation. This blast evaluation consisted of impulsively shock loading a boot encased cadaver foot with an M-14 APERS land mine. This land mine is shown in Figure 24 taken from TM-9-1940.

Concepts A and B included a molded heel and sole as shown in Figure 22 and 23 while Concepts C, D, and E were blast prototypes of a somewhat simplified character as shown in Figures 20 and 26. The differences in the rubber outsole were not considered to be of major importance for this series of experiments. The outsole material used for Concepts A and B was a urethane rubber of approximately 70 durometer shore A while the rubber shank covering for Concepts C,D, and E was approximately 60 durometer, 1/8 inch thick neoprene. Blast experiments with a production type molded sole and heel (Paracril Ozo, primarily) will be discussed later.

A. Test procedure

The boot and cadaver foot system was held in the CRDL test fixture shown in Figure 25. This device consists of a metal cone (item A), which restrains the upward movement of the cadaver leg. Various links and pivot points are included in the design of the fixture in order to simulate the various joints of the human anatomy, but these factors are of secondary importance for the relatively short time durations involved here. The metal box directly above point E holds the mass which results in a total of approximately 160 pounds above the cadaver leg.

The boot encased foot was attached to the CRDL test fixture and positioned so that the sole and heel were in contact with the upper surface of the land mine. The leading edge of the heel was centered over the land mine. The M-14 APERS land mine was buried with only its pressure plate exposed. The land mine was emplaced by tamping an oversize depression in the soil, centering the land mine in the depression, and finally filling in the area around the mine with the local soil.

B. Damage to the cadaver specimens with protective concepts A, B, C, D, and E

Figure 27 indicates the nature and degree of damage to cadaver lower extremities exposed to the blast effects of the M-14 mine. The upper specimen was encased in a conventional stitched combat boot and the lower specimen was encased in a conventional direct molded sole combat boot. These typical examples indicate a level of damage which can be used as a reference point for evaluating the results of the various protective boot concepts. Both of the cases shown would lead, obviously, to an amputation of at least the foot.



Figure 22 CONCEPT A, BLAST PROTECTIVE FOOTWEAR



Figure 23 CONCEPT B, BLAST PROTECTIVE FOOTWEAR

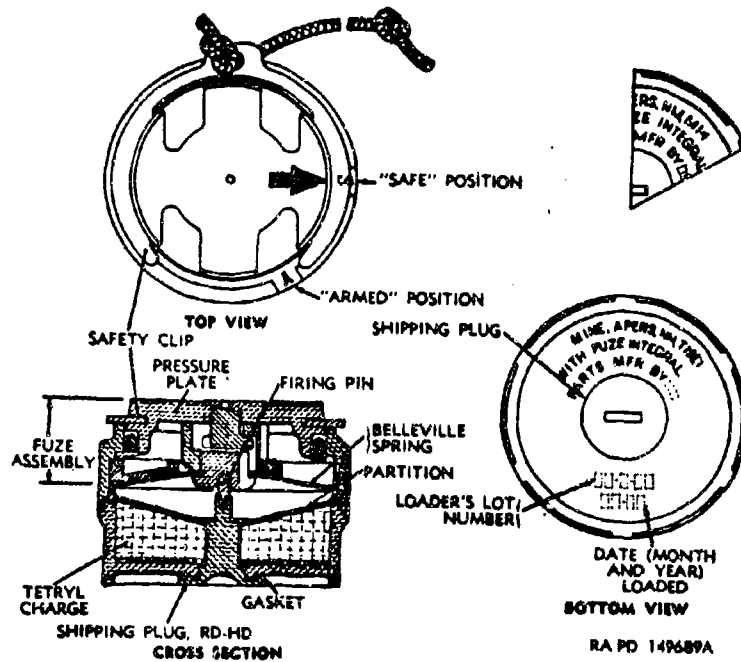

Charge Weight 1 ounce
 Mine Overall Weight $3\frac{1}{3}$ ounces
 Dimensions-Height, $1\frac{9}{16}$ inches
 Diameter, $2\frac{3}{16}$ inches
 Body Material - High Impact Styrene

Figure 24 - ANTIPERSONNEL LAND MINE U.S. ARMY M-14 APERS
 (Taken from TM 9-1940)

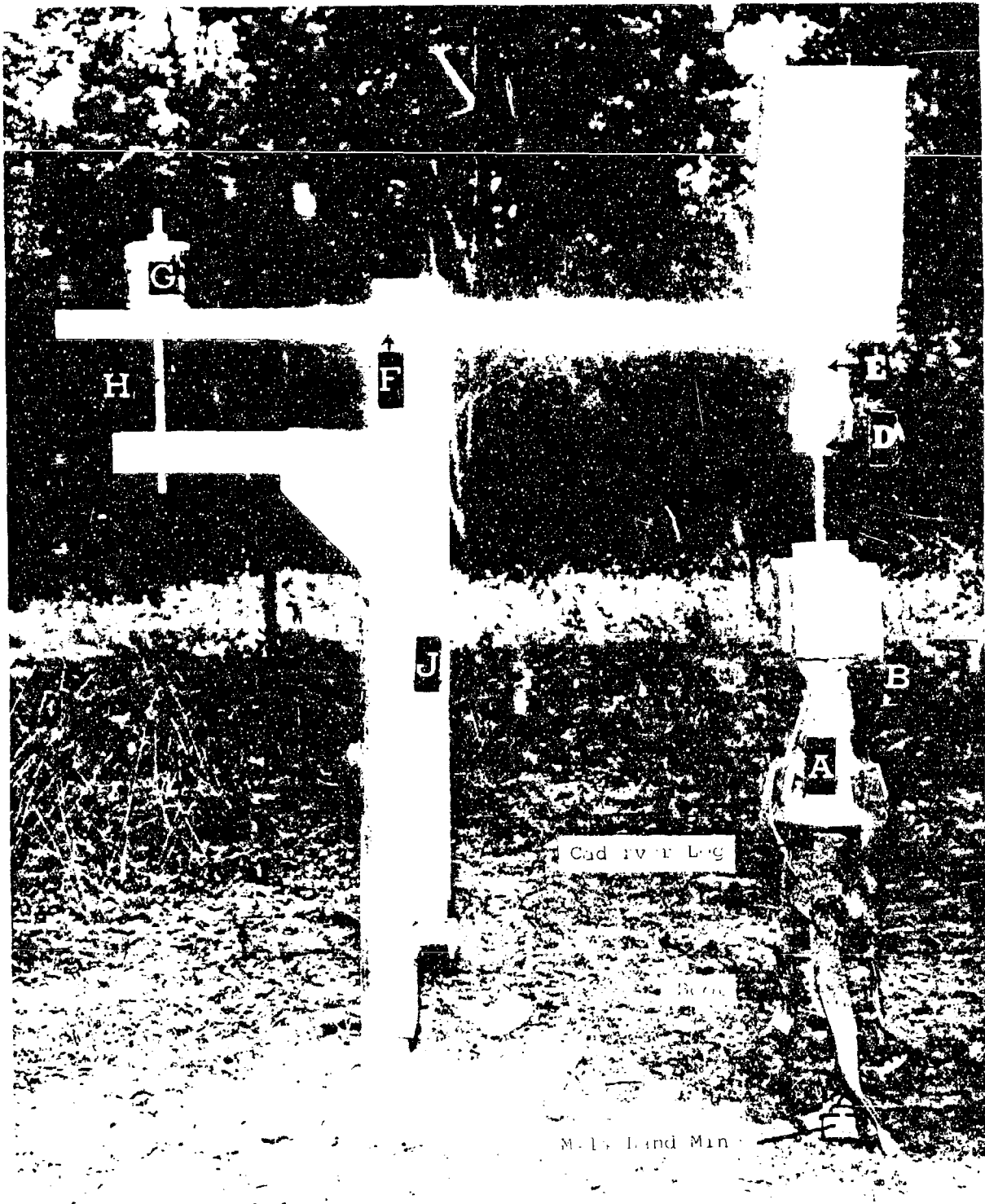

Figure 25

CRDL TEST FIXTURE FOR BLAST EVALUATION
OF PROTECTIVE FOOTWEAR.

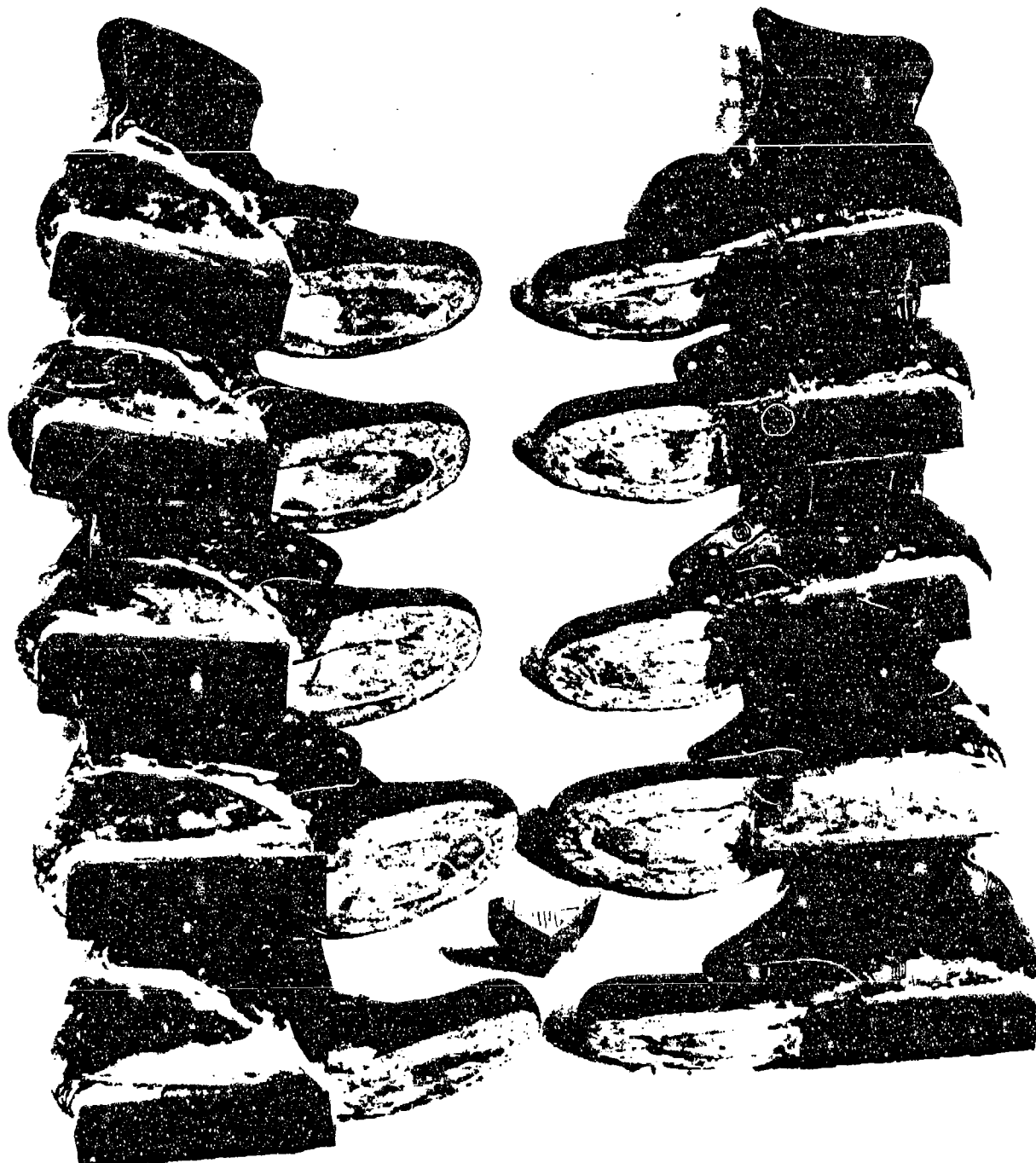
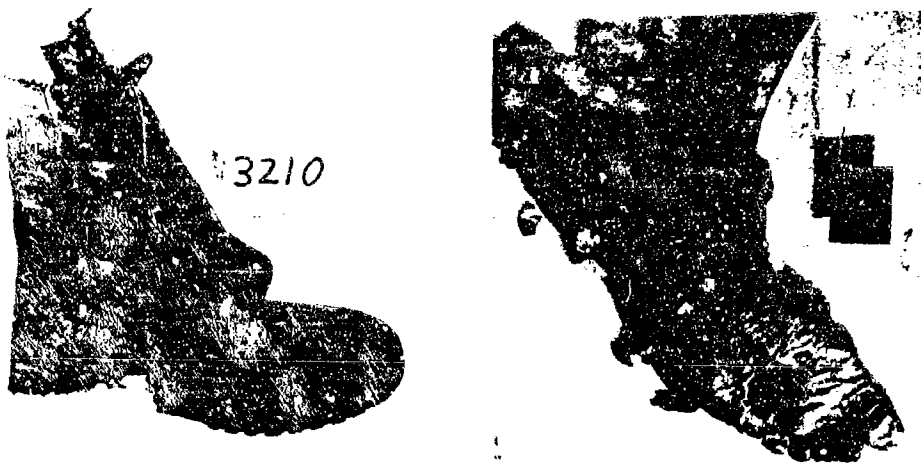

Figure 26

CONCEPT D (On Left) AND CONCEPT E OF BLAST PROTECTIVE FOOTWEAR.



STITCHED BOOT



DIRECT MOLDED SOLE BOOT

FIGURE 27 LANDMINE INDUCED DAMAGE TO A STANDARD
STITCHED BOOT AND A STANDARD DMS BOOT
WITH RESULTING FOOT DAMAGE
(Photographs from Biophysics Div., CRDL)

The cadaver feet specimens shown on the right
were placed in the boots shown on the left.
An M-14 mine was the source of the impulsive
blast loading.

Figures 28 through 34 indicate the damage to cadaver lower extremities protected by protective Concepts A, B, C, D and E. In Figures 28 and 29, specimen number 3139 of Concept A sustained considerably greater damage than the other Concept A specimens. This is probably due to the deterioration of this particular cadaver and serves to illustrate a point which medical personnel are quick to make; namely, cadaver specimens can only be used to provide a rough estimate of the results which can be expected with a living specimen.

One might also note that almost all of these specimens were obtained from unclaimed bodies and were considerably older and probably in poorer health than a typical combat soldier. This fact plus the deterioration of the cadaver specimens tend to make the following results conservative. A combat soldier would fare better than the cadaver specimens indicate.

From the foregoing discussion it can be deduced that a definite amputation requirement was indicated for one out of four of the Concept A specimens, all four of the Concept B specimens, two out of five of the Concept C specimens, none of the Concept D specimens, and three out of five of the Concept E specimens. Tables I and II present this data in detailed form.

The damage has been broken down into five categories, based on medical opinion, as follows:

1. Definite amputation
2. Probable amputation
3. Indeterminate
4. Probable salvage
5. Definite salvage

The first category includes all of the specimens which were adjudged to present no possibility of salvaging the foot. A lower leg amputation would inevitably result in these cases. The second category is not certain to result in an amputation but the medical judgment leans toward that conclusion. The third category is indeterminate in that no immediate medical conclusion can be drawn. The fourth category will probably not result in an amputation, and the fifth category is felt to encompass all the specimens which will not require an eventual amputation.

A numerical value from 1 to 5 is placed on each of the five assessed damage levels so that a "numerical average" can be determined for each protective concept. The numerical average rating of each protective concept can then be determined. Since this numerical average is based on a very limited number of samples, small differences in the values are not significant. Concept A at 2.25 average is not significantly superior to Concept E at 2.00 average, for example. Concepts C and D at

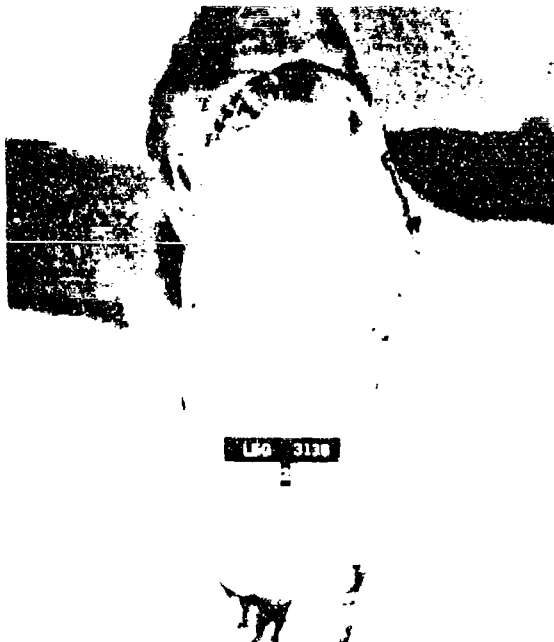

Concept A



Concept A



Concept B



Concept B



Concept B
with 1/2" Foam

Figure 28

BOTTO VIEW OF CADAVER LOWER EXTREMITIES
PROTECTED BY CONCEPTS A AND B
(Photographs Provided by CRDL)

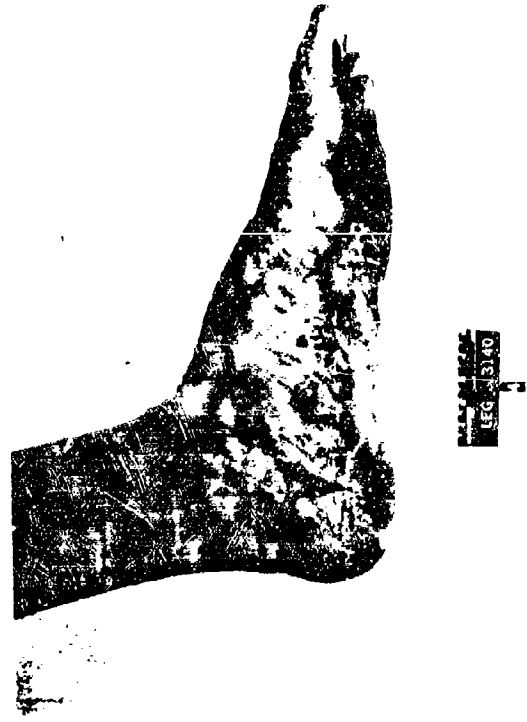
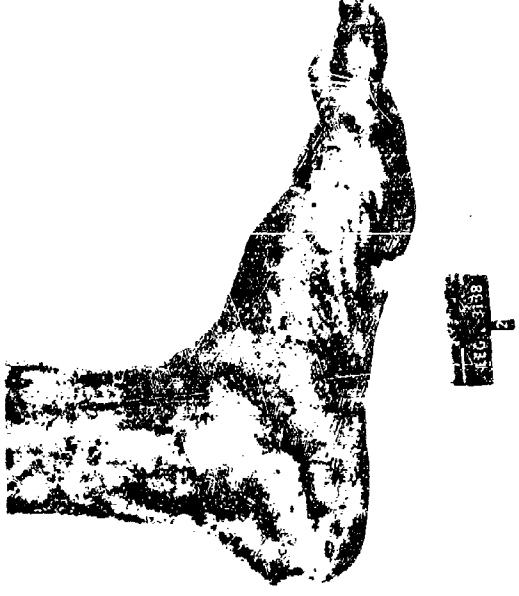
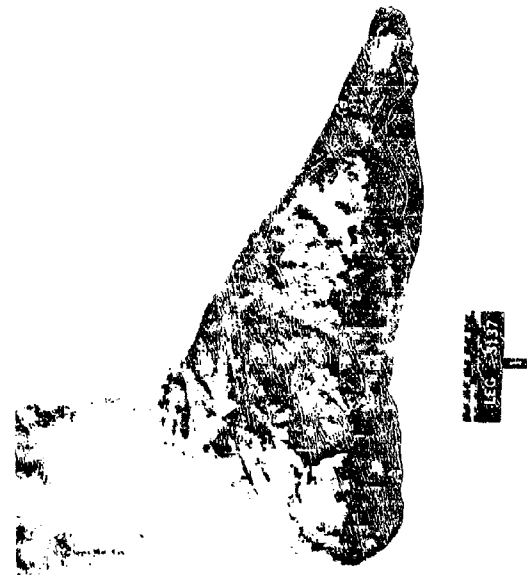
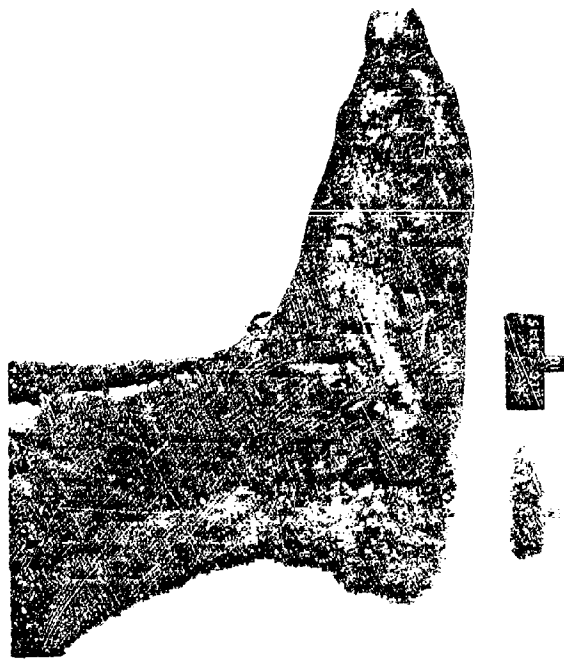
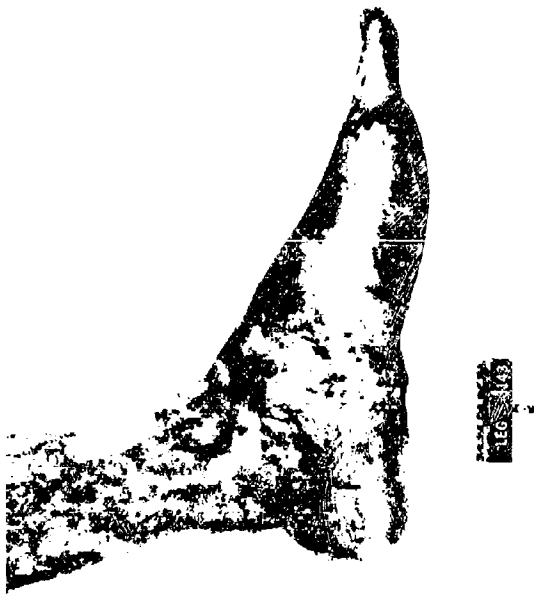
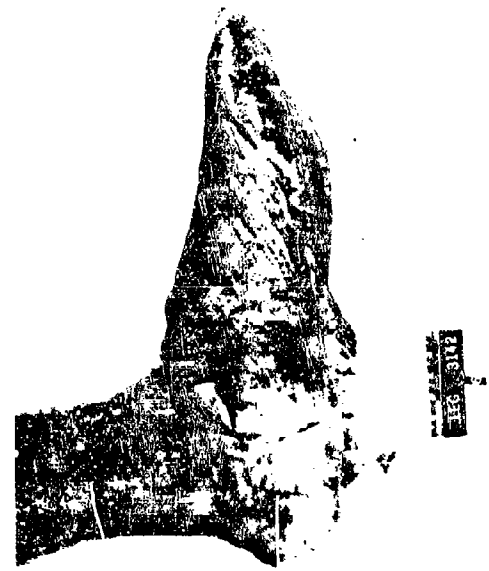

Figure 29 CADAVER LOWER EXTREMITIES PROTECTED BY
CONCEPT A BLAST PROTECTIVE FOOTWEAR
(Photographs Provided by CRDL)



CADAVER LOWER EXTREMITIES PROTECTED BY CONCEPT B
BLAST PROTECTIVE FOOTWEAR
(Photographs provided by CRDL)

Figure 30

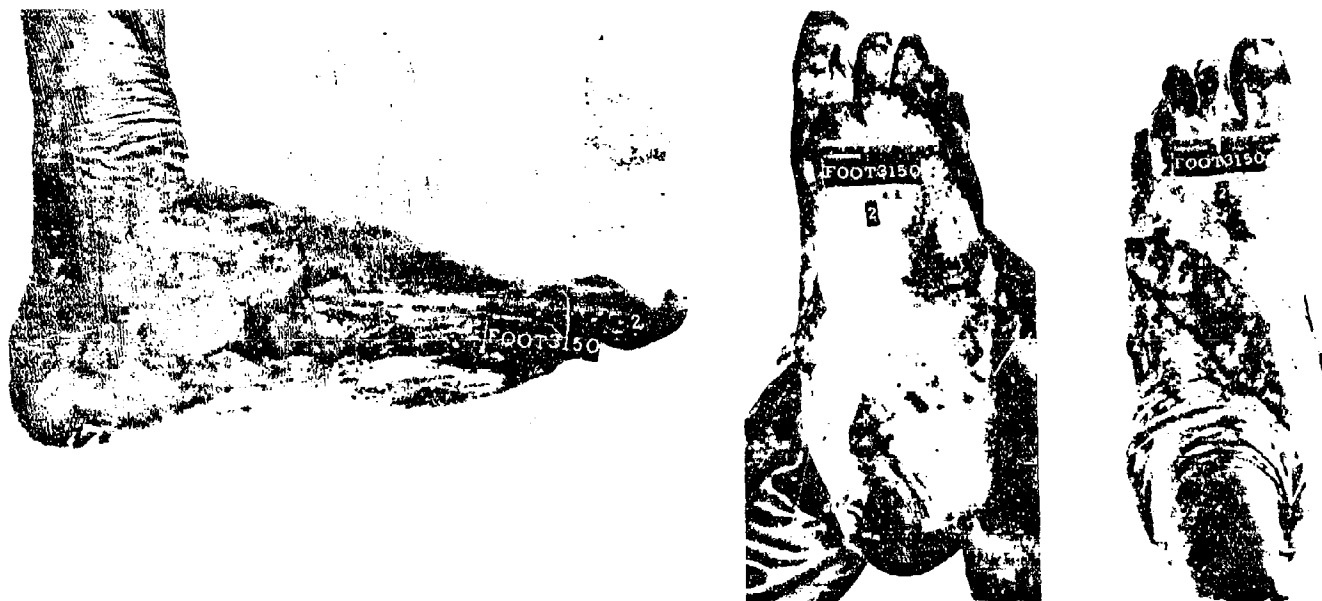

Figure 31

CADAVER LOWER EXTREMITIES PROTECTED BY CONCEPT C
BLAST PROTECTIVE FOOTWEAR

(Photographs provided by CRDL)



Figure 32 CADAVER LOWER EXTREMITIES PROTECTED BY
CONCEPT D BLAST PROTECTIVE FOOTWEAR

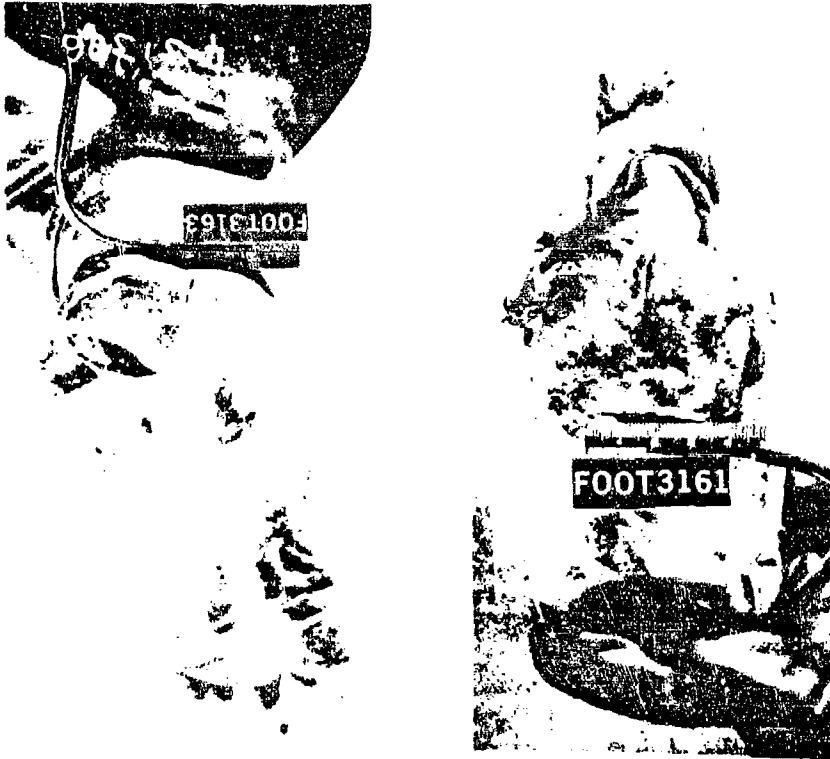

Figure 33 CADAVER LOWER EXTREMITIES PROTECTED BY
CONCEPT E BLAST PROTECTIVE FOOTWEAR
(Bottom View)

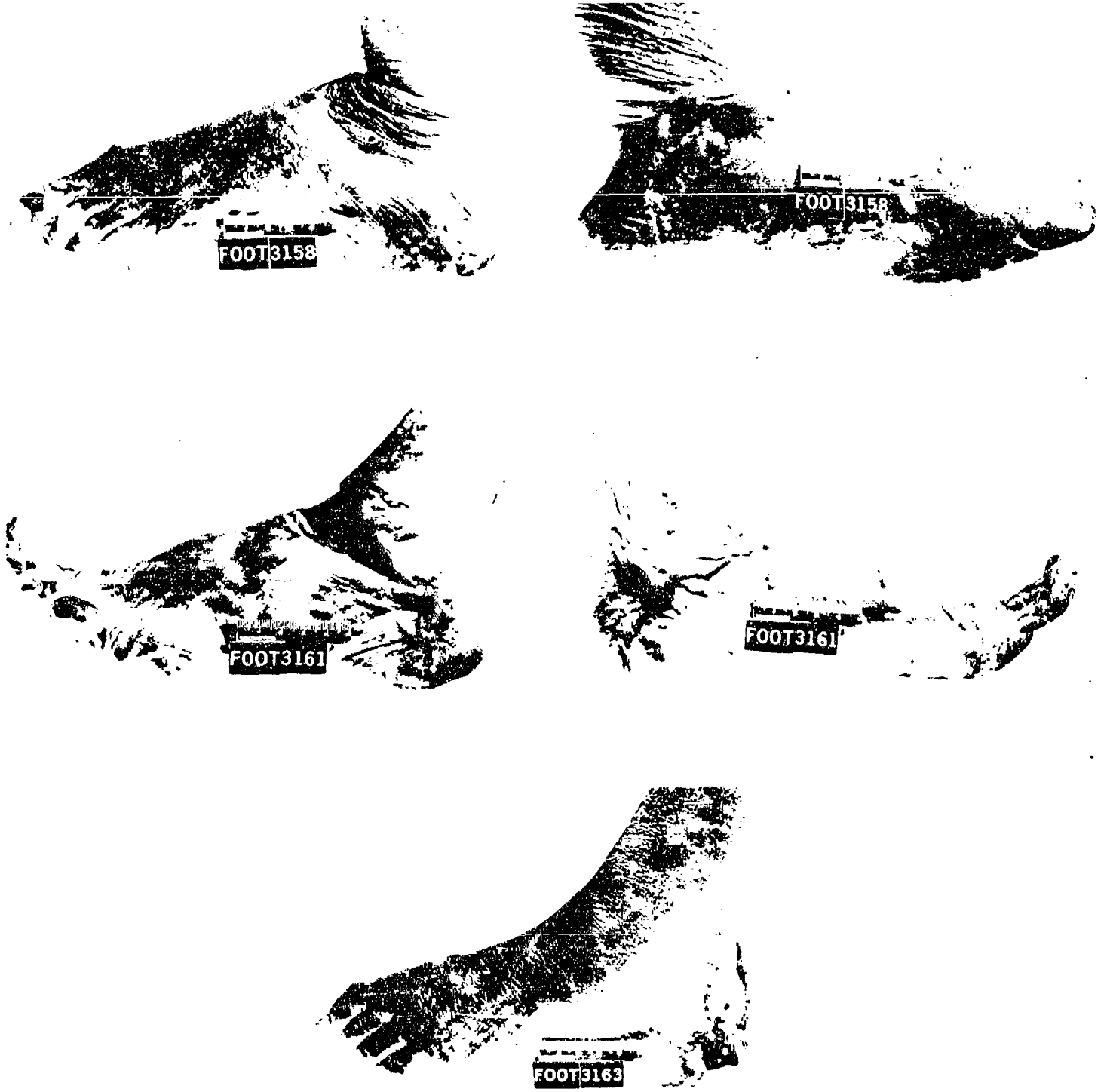

Figure 34

CADAVER LOWER EXTREMITIES PROTECTED BY
CONCEPT E BLAST PROTECTIVE FOOTWEAR
(Side View)

Table I

AUTOPSY DAMAGE ESTIMATE FOR HUMAN LOWER EXTREMITIES
ENCASED IN IITRI PROTECTIVE FOOTWEAR

CRDL TEST NUMBER	IITRI CONCEPT	BRIEF DESCRIPTION	AUTOPSY ANALYSIS					
			← increasing damage →					
			Def Amp	Prob Amp	Indet	Prob Sal	Def Sal	
1	2	3	4	5				
3137	A	15/16x2x6", 7.2 oz.						
38	A	Multipiece, 15.3/23.1 lb/ft ³						
39	A	No heel cup						
40	A*							
42	B	15/16x2x6", 5.82 oz.						
43	B	Single piece, 15.3 lb/ft ³						
44	B	No heel cup						
45	B**							
49	C	6" long, 23.1 lb/ft ³ ***						
50	C	6" long, 19.2 lb/ft ³ ***						
51	C	6" long, 15.3 lb/ft ³ ***						
52	C	5" long, 15.3 lb/ft ³ ***						
53	C	5" long, 23.1 lb/ft ³ ***						
54	D	1-1/16x2-5/8x6" 16 oz. multi-						
57	D	piece 19.2/23.1 lb/ft ³						
59	D	heel cup						
60	D							
62	D							
55	E	Same as D above except						
56	E	wt.-8.7 oz. and no heel cup						
58	E							
61	E							
63	E							





* Plus 1/8" Rubber























** Plus 1/2" Foam

*** 1-1/16x2" wide with heel cup in all cases. Total wt. approximately 14-15 oz.

Table II

OSG DAMAGE ANALYSIS OF PROTECTED LOWER EXTREMITIES
EXPOSED TO AN M-14 LAND MINE

<u>SYMBOL</u>	<u>OSG EVALUATION</u>	<u>NUMERICAL EVALUATION</u>
	Definite Amputation	1
	Probable Amputation	2
	Indeterminate	3
	Probable Salvage	4
	Definite Salvage	5

	1	2	3	4	5	<u>NUMERICAL AVERAGE</u>
Concept A						2.25
Concept B						1.0
Concept C						3.4
Concept D						3.4
Concept E						2.0

OVERALL (CONCEPTS A, B, C, D & E) ANALYSIS

5 ea.	Definite Salvage	22%	} 30%	} 39%
2 ea.	Probable Salvage	9%		
2 ea.	Indeterminate	9%		
4 ea.	Probable Amputation	17%		
10 ea.	Definite Amputation	43%		
23 ea.	TOTAL	100%		

3.4 average are significantly superior to Concepts A and E, however; and Concept B at 1.0 average is clearly inferior to any of the other concepts in protective qualities.

The five protective footwear concepts can be clearly ranked into three categories in terms of levels of protection. Concepts C and D provide the highest level of protection; Concepts A and E provide an intermediate level of protection while Concept B resulted in four definite amputations out of four experiments.

The soft tissue damage and bone fractures are discussed in detail in the autopsy reports in Appendix C. The Concept A cadaver specimens all suffered soft tissue damage along with numerous bone fractures including a comminuted calcaneus in all instances. The Concept B specimens generally suffered greater soft tissue and bone damage than the Concept A specimens. The Concept C specimens had no skin lacerations in three of the five cases with only minor lacerations in the other two. Bone damage appeared to be somewhat less for the Concept C specimens than for the Concept A or B specimens. The Concept D specimens sustained no skin lacerations in the five experiments. The calcaneus was comminuted in all cases, but in one case there were no other fractures and in two cases only one other bone was fractured. Of the five Concept E specimens, one had no skin lacerations. The calcaneus was comminuted in all cases, but in one instance the only other fractures were "minor chip fractures of the articular head of the tibia."

C. Damage to the boot and shank for concepts A, B, C, D and E

A number of variables were evaluated during this series of experiments involving Concepts A through E of protective footwear. The protective shank utilized crushable aluminum honeycomb in a number of different densities and the shank itself was tested in two widths, two lengths, and two thicknesses. Figure 35 shows the shank cross section on the left with the typical results of the blast loading on the right.

Concept C was the only system involving variables within the concept. The upper honeycomb layer density was varied as well as the shank length. The Concept A and B shanks were 15/16 inches thick, two inches wide, and six inches long. The Concept D and E shanks were 1-1/16 inches thick, 2-5/8 inches wide, and six inches long. The Concept C shank was 1-1/16 inches thick and two inches wide, but the length was either five or six inches and the upper honeycomb layer was either 23.1, 19.2, or 15.3 lb/ft³. These details are indicated on Table C 3 in Appendix C.

The overall damage to the boots is shown in Figures 36 and 37. Figures 38 and 39 show the interiors of Concepts A, B and C after blast loading. Concept A suffered only minor splitting of the insole while Concept E was perforated through in all cases except the one in which 1/2 inch of foam was placed between the mine and the boot. Concept C did not indicate any insole perforations, as shown in Figure 39. The same is true for Concepts D and E.

The crushing of the various shanks is shown in Figure 35. In addition, Figure 40 indicates the Concept A and B crushing in greater detail and Figure 41 shows the Concept C variables with the upper honeycomb layer and the shank length specified.

D. Conclusions based on the blast evaluation of concepts A, B, D, and E

Concept C and D provided the highest level of protection. Concept A and E can be grouped next while Concept B was unsuccessful in preventing amputation although the damage level was considerably less than for an unprotected foot in a conventional boot.

Concepts C and D both employed the 1/32 inch thick steel heel cup and this is primarily responsible for the superiority of Concepts C and D over Concepts A and E. The heel cup weighed approximately 7.2 ounces, however, and this must be considered in the evaluation of any overall system.

Concepts A and E provided approximately the same degree of protection based on the limited number of experiments considered. However, a study of the permanent deformation sustained by the shank and the leather upper indicates that Concept E will theoretically provide a greater degree of protection than Concept A. The upper layer of honeycomb in Concept E was not crushed to solid whereas the upper layer of honeycomb in Concept A was crushed to solid implying that a peak pressure of unknown amplitude was transmitted by Concept A at the instant at which it crushed to solid. The leather insole of Concept A exhibited a small amount of splitting while the Concept E insole was undamaged. Most of the difference in the crushing of the upper layer of honeycomb is probably attributable to the greater thickness and the higher density of the Concept E upper layer rather than to the greater width of the Concept E shank.

Concept B was the only protective system involving a single honeycomb layer. The single honeycomb layer used in this case was of 15.3 lb/ft³ nominal density. A study of the permanent deformation sustained by this system indicates that the honeycomb crushed to solid in all cases. Since crushing to solid is generally accompanied by the generation of an impact stress of undetermined magnitude it is likely that the performance

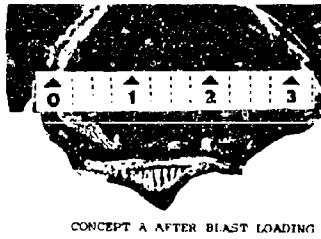
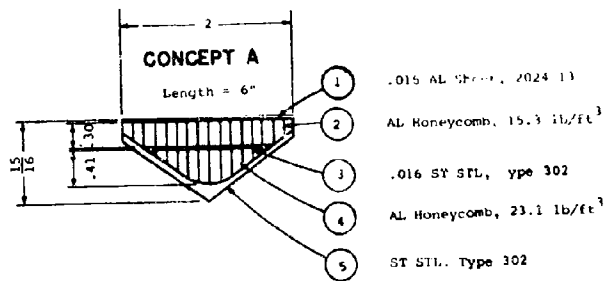

CONCEPT A AFTER BLAST LOADING

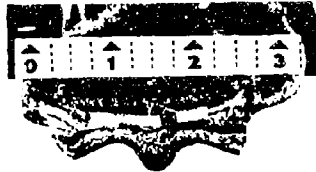
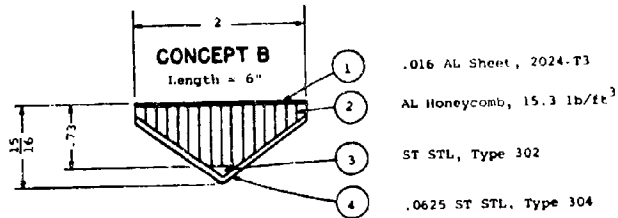

CONCEPT B AFTER BLAST LOADING

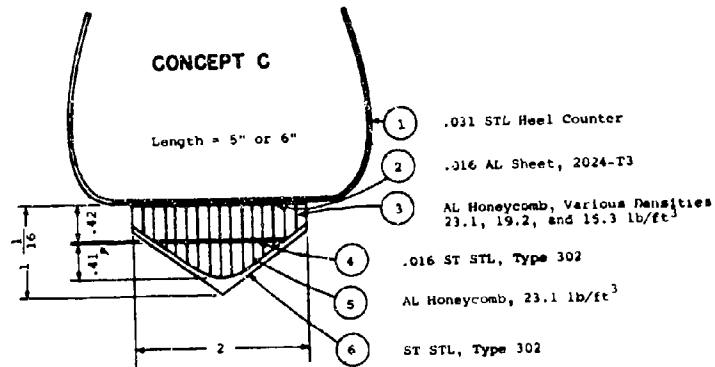

CONCEPT C AFTER BLAST LOADING
Upper Honeycomb - 19.2 lb/ft³

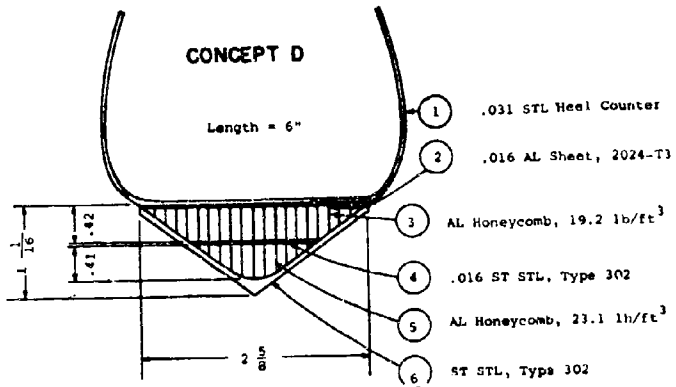

CONCEPT D AFTER BLAST LOADING

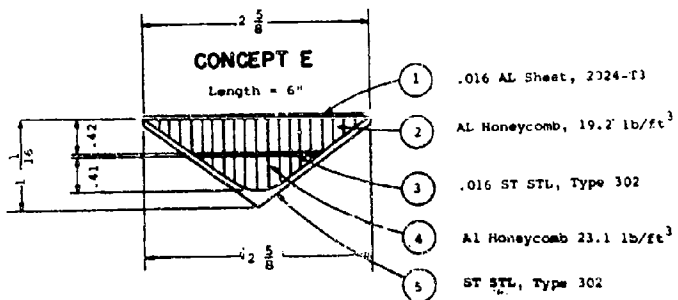

CONCEPT E AFTER BLAST LOADING

Figure 35 SECTION VIEW OF CONCEPTS A,B,C,D, and E OF BLAST PROTECTIVE FOOTWEAR AFTER BLAST LOADING (on right)



BOOT 3137



Concept A

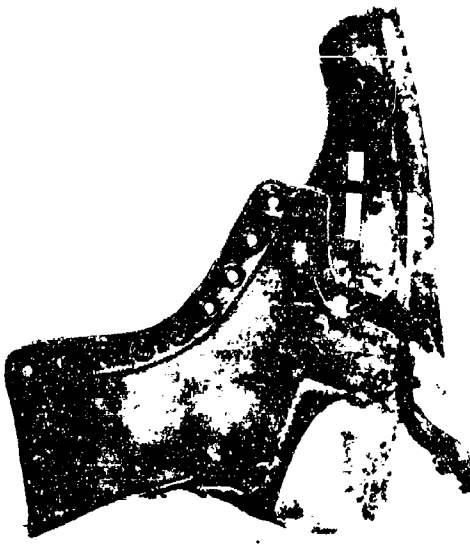

BOOT 3144



Concept B

Figure 36 BOOT DAMAGE FOR CONCEPTS A AND B



Concept C



Concept D



Concept E

Figure 37 BOOT DAMAGE FOR CONCEPTS C,D AND E

BLANK PAGE



BLAST PROTECTIVE FOOTWEAR AFTER EXPOSURE TO
AN M-14 APERS LAND MINE
CONCEPTS A ON LEFT AND CONCEPTS B ON RIGHT

Figure 38





Figure 39

INTERIOR VIEW OF CONCEPT C AFTER BLAST LOADING

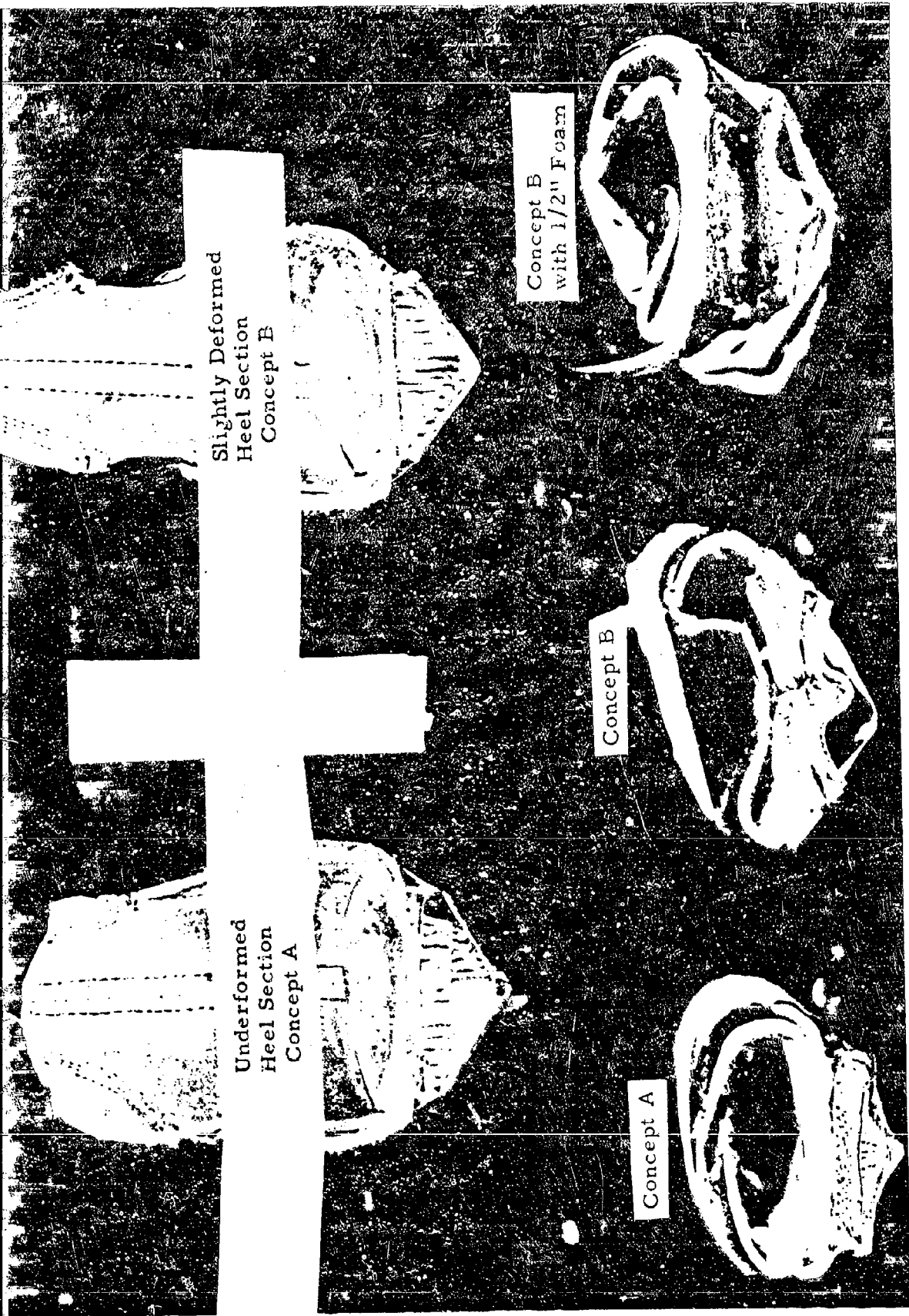

Figure 40 SECTION VIEW OF BLAST PROTECTIVE FOOTWEAR CONCEPTS A AND B



Figure 41 SECTION VIEW OF BLAST PROTECTIVE FOOTWEAR CONCEPT C

of
ho
wa
of
in
di
th
Th
la

me
sh
Si
fe
ap
in

A,
an
nc
la
cr
sc
ne
up

pr
sh
th
ho
as
li
be
ou
th
fo

of Concept B would have been somewhat better if a higher density honeycomb layer were used. Evidence that crushing to solid was accompanied by a high impact stress is shown by the failure of the leather insole which was perforated in a manner similar in appearance to the catastrophic failure of a pressure ruptured diaphragm. The single layer concept is considered further in the production type footwear with a higher density honeycomb. This is done because of the potentially lower cost of the single layer construction.

An overall survey of all of the Concept A through E experiments indicates that there is no apparent correlation between shank width and level of protection for the two widths studied. Since the narrower two-inch-wide shank will generally present fewer problems in the fabrication of completed footwear, there appears to be no need to pursue the evaluation of the wide shank into the small lot production phase of the program.

The two-layer honeycomb protective shanks used in Concepts A, C, D, and E were of various lengths, widths, thicknesses, and honeycomb densities. It appears that the 19.2 lb/ft³ nominal density upper layer combined with the 23.1 lb/ft³ lower layer provides the optimum combination based on the theoretical criteria of a maximum degree of crushing without crushing to solid. The crushing is of such a nature that the overall thickness of the shank can be held to one inch with the 19.2 lb/ft³ upper layer.

The metal heel cup used with Concepts C and D definitely provides a higher level of protection than the same protective shank without a heel cup. The 1/32 inch thick steel used in the Concept C and D heel cups weighed approximately 7.2 ounces, however, and the heel cup thus weighs approximately the same as a complete protective shank. It is likely that a smaller, lighter heel cup would provide a level of protection somewhat better than the shank alone but not as good as the large 7.2 ounce heel cup. The heel cup concept is considered further in the production type footwear in a somewhat lighter, smaller form.

PART IV. PRODUCTION OF DMS PROTECTIVE FOOTWEAR

The final selection of the detailed blast protective boot requires the fabrication and blast evaluation of a system which duplicates the production item in all significant respects including the outsole material and configuration. This required the fabrication of direct molded sole footwear by the CEMA process in the C.I.C. molding machine. The nitrile rubber material (basically Paricril Ozo from U. S. Rubber) was compounded by Genesco, Inc., and the molding was done at their subsidiary, Safety First Shoe Co., of Huntsville, Alabama.

A number of different types of protective boots were fabricated in this manner incorporating three variables; these were shank honeycomb configuration, outsole configuration, and heel counter. There were two variations of each of the three variables resulting in a total of eight different combinations. Each of these eight combinations was fabricated in a quantity of ten pairs resulting in the first lot of 80 pairs of protective boots. A second lot of 70 pairs of boots was fabricated later based on the results of the large scale blast evaluation of the first lot samples.

A. Boot variables

The shank used in the production of the first lot of 80 pairs of boots was of two types of construction, a one-piece honeycomb and a two-piece honeycomb. Figure 42 illustrates the difference between the two shanks. The exterior envelope is essentially the same for the two shanks and the piece parts item 1 and item 2 are exactly identical.

The outsole configuration was also fabricated in two types as shown in Figures 2 and 3. Figure 2 indicates the preferred cutaway heel and Figure 3 shows a full heel version of the same outsole. The cutaway heel is theoretically more efficient in terms of reduced impulse input and also weighs approximately 1.5 ounces less.

The heel counter was either the standard leather counter or the metal counter shown in Figure 21. The metal counter which was used in these concepts weighs 3.15 ounces or less than half of the Concept C and D counters. Also, since the conventional leather counter weighs 0.86 ounces, the weight added to a boot by the small metal counter is only 2.29 ounces total.

B. Production methods

The shanks were assembled with an epoxy adhesive per IITRI specification number 285700 (see Appendix B). The specification is for the one-piece shank but the two-piece shank is essentially similar. The boot itself was fabricated generally in accordance with QM Procurement Purchase Description LP/P DES 37-62

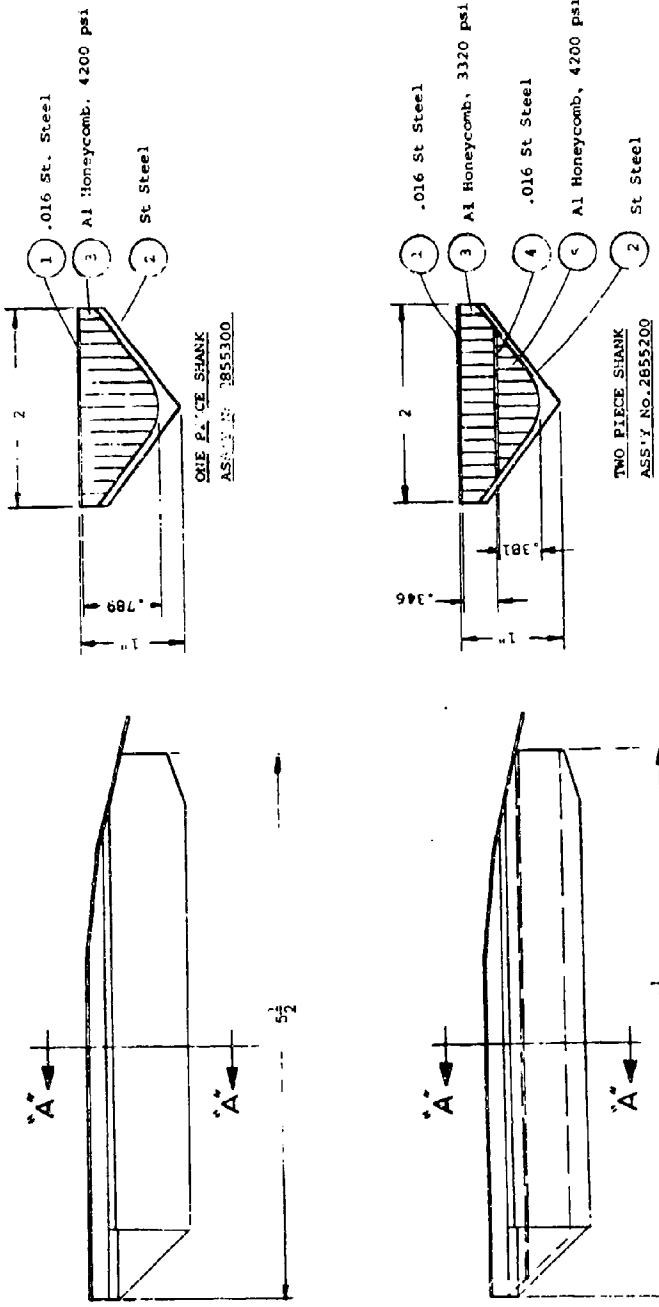

Figure 42 TWO SHANK TYPES EVALUATED IN PRODUCTION TYPE PROTOTYPES

dated 17 October 62, except as noted in IITRI specification 2857000 (Appendix B).

The C. I. C. molding machine is shown in Figure 43 with the protective boot uppers in place. Note that the counter pocket is somewhat longer than standard and is used flesh side out. This was done in order to facilitate assembly with the protective shank and to increase the adhesion of the rubber outsole to the leather. The only modification to the molding machine required for the protective boot involves the mold sole pistons which were designed to allow for inclusion of the shank. Figure 44 shows the mold sole pistons (left foot only) which produce the required sole pattern for the protective boot outsole. The full heel version is shown on the left and the cut-away heel is shown on the right. Since the sides of the sole pistons are vertical, the mold side plates did not have to be altered.

Prior to mounting the boot uppers on the molding machine lasts, the shank must be held in place as shown in Figure 45. The leather upper is coated with a suitable adhesive and a thin layer of outsole rubber is placed between the upper and the shank. The shank is nailed in place and the counter pocket is lapped over and laced as shown. All shanks were coated with BOSTIK 4034 adhesive to aid the metal to rubber bond.

The metal counters were generally located in the same position as the leather counters. Figure 46 indicates two methods of securing the counter pocket in place. The upper figure indicates an adhesive bonding technique. BOSTIK 4034 adhesive was used for this application.

1. Molding cycle

The outsole for the protective boot was intended to be about 1/16 inch thicker than the conventional outsole. This would add about two ounces to the overall weight of the outsole. A small amount of slope (about 0.5 degree) in the sole piston to side plate relationship resulted in the major portion of the thickness increase being in the forepart of the outsole. This thickness may have contributed to the long cycle time required for adequate curing of the rubber in this region. A 25-minute cure cycle was required with a 150°F rubber biscuit preheat. This sequence compares to an approximately 15-minute cure cycle with the standard outsole and no pre-heat required.



A. C. I. C. Molding Machine Shown With
A Pair Of Protective Boots



B. Close View Of Boot In
Place For Molding

Figure 43 C.I.C. MOLDING MACHINE

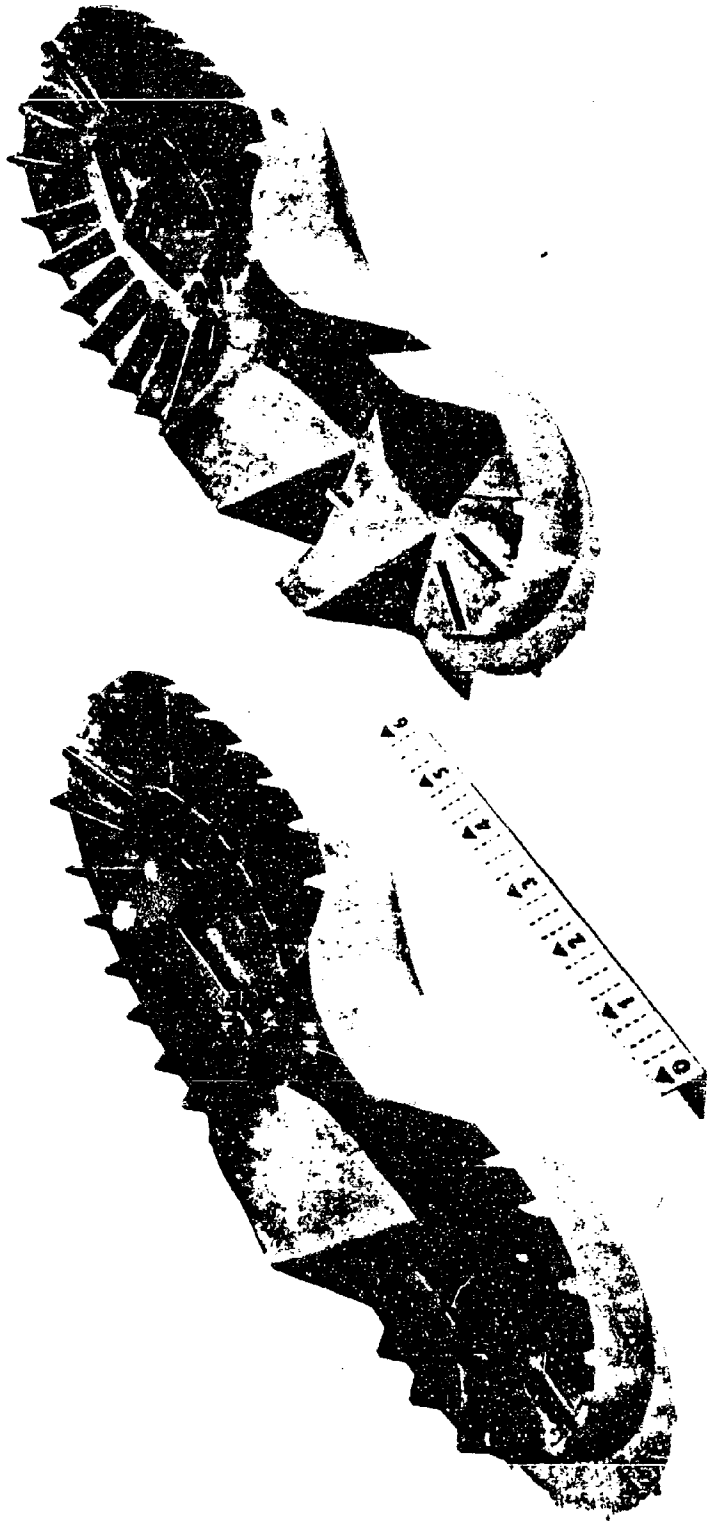

Figure 44 FINISH MACHINED MOLD SOLE PISTONS



A. Bo
Re



Boot Upper With Adhesive
Ready For Emplacing Shank



B. Shank In Place With Lacing
Across Forepart



C. Shank In Place With Lacing
Across Forepart

Figure 45 - SHANKS SHOWN LACED IN PLACE FOR MOLDING

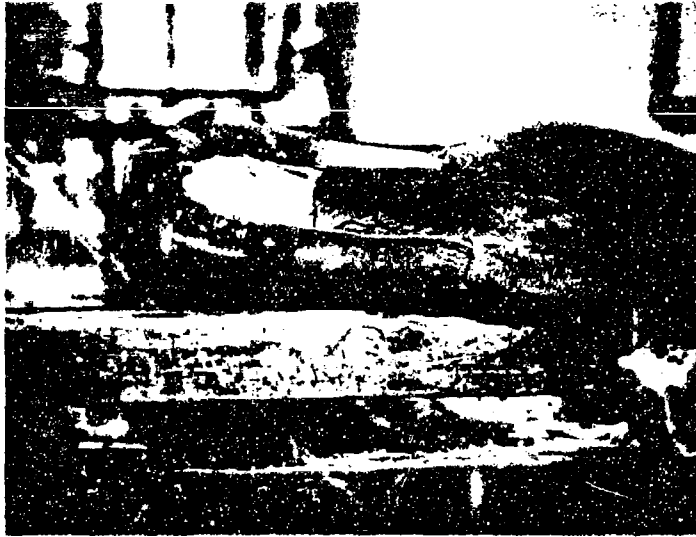

A. Counter Pocket Nailed In Place

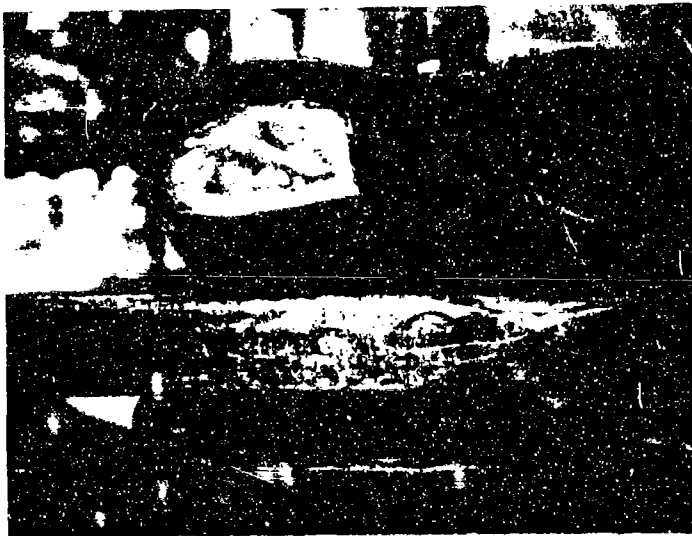

B. Counter Pocket Ready For Adhesive
Bonding In Place

Figure 46 - EMBLEMMENT OF METAL COUNTERS

2. Thermal cycle during curing

Since the long dwell time in the mold will contribute to decreased production rates and increased cost, a brief experiment was conducted in order to determine the nature and extent of the problem.

One sample boot was instrumented with three thermocouples and a direct reading Simpson 388-3L meter. Temperature readings were taken at each of the three positions periodically over the 25-minute molding cycle and a few minutes beyond. Figure 47 shows the temperature-time relationship at the three positions.

Thermocouple number 1 was located next to the leather insole at approximately the center of the ball of the foot. Thermocouple number 2 was mounted on the lower surface of the metal protective shank approximately in the center of one of the flat surfaces which make up the external shank wedge. Thermocouple number 3 was approximately centered between the shank and the leather insole.

The thermal cycle included a 25-minute uncured rubber pre-heat at 150°F. This accounts for the high temperatures indicated at thermocouples number 1 and number 2 at the beginning of the recording period shown on Figure 1. Thermocouple number 3 (above the shank) did not come into direct contact with the pre-heated rubber slug and only indicated 108°F at the beginning of the cycle. This slight differential above room ambient was probably due to the effects of the warm last.

Thermocouple number 2 (below the shank) registered 130°F at the beginning of the molding cycle and rose to a high of 292°F near the end of the 25-minute cycle. This was the highest temperature recorded at any of the thermocouple locations and was, in fact, 50°F higher than the maximum temperature recorded at thermocouple number 3 (above the shank). Thermocouple number 1 at the ball of the foot required approximately 10 minutes to record 200°F even with the initial pre-heat temperature of 130°F. After 25 minutes, thermocouple number 3 only reached a maximum of 213°F.

Based on the time-temperature data shown in Figure 47, it is likely that a redesign of the mold heating system and perhaps an additional last heating system would help to minimize the temperature differences within the mold and could result in a considerably shortened molding cycle.

The 25-minute molding cycle currently in use for the DMS boot incorporating a protective shank is based on a 400-gram rubber outsole for the cutaway heel version. The heel thickness is approximately 1.406 inches compared to the standard 1.275 inches and the sole thickness at the toe is approximately 0.762 inch as compared to the standard 0.625 inch. There is apparently about a 0.5° slope in the mold sole piston (relative

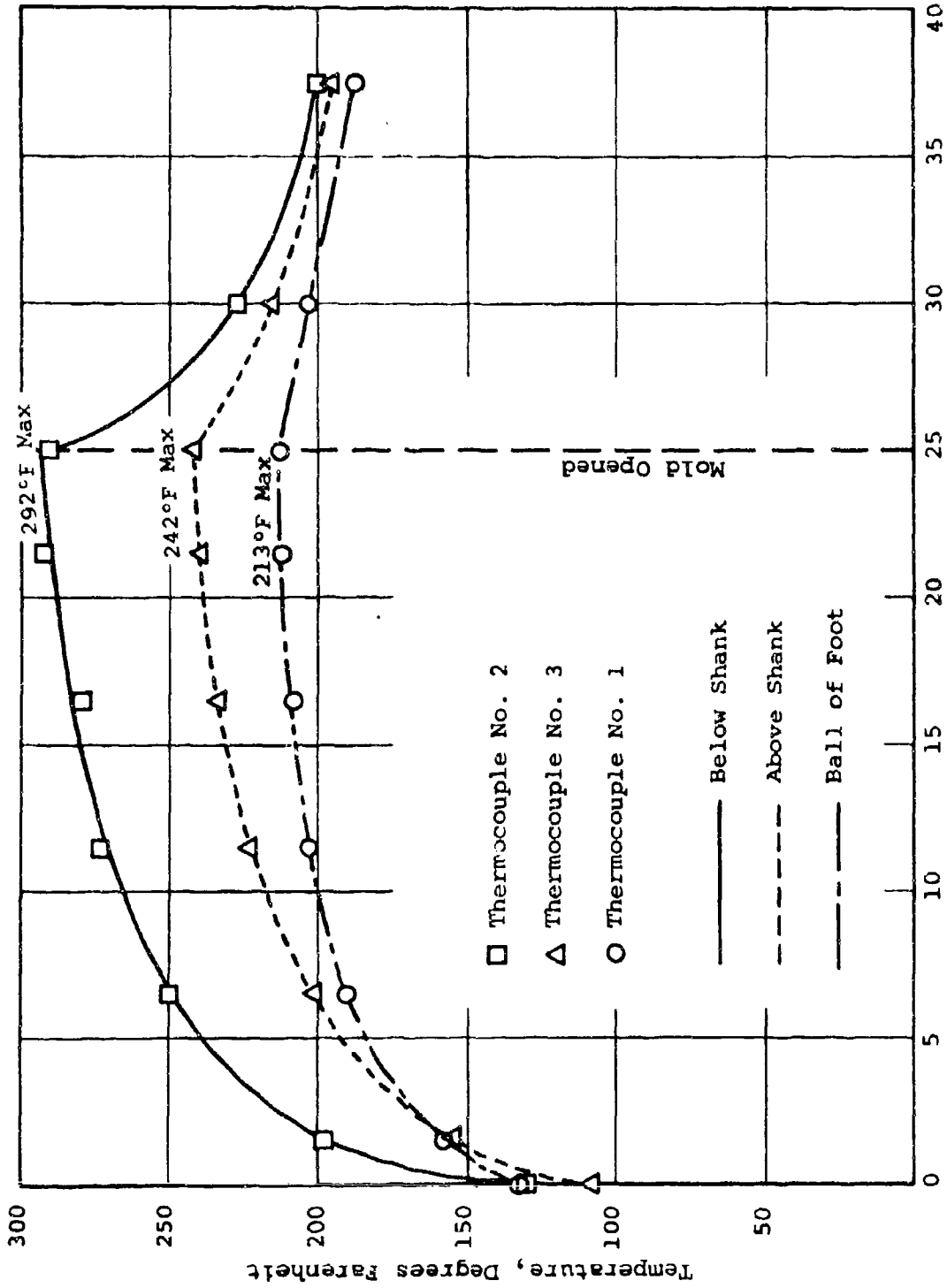

FIGURE 47 TEMPERATURE RISE AT VARIOUS POINTS IN THE DIRECT MOLDED BOOT OUTSOLE DURING VULCANIZATION

to the side knife edges), which tends to thicken the sole towards the toe. The average overall thickness increase for the protective boot outsole is approximately 0.084 inch as compared to the standard average thickness.

PART V. BLAST EVALUATION OF THE PRODUCTION TYPE DMS PROTECTIVE COMBAT BOOTS

The eight variations of the DMS protective combat boot described in Part IV were blast tested with cadaver lower extremities and the M-14 land mine. A total of 64 tests was conducted including eight each of the eight boot variations. Forty-eight of the specimens were held in the CRDL test fixture loaded with a total of 160 pounds of mass as described in Section III-A. The other sixteen specimens were tested free standing above the land mine and essentially unrestrained. These specimens were propelled approximately 20 to 25 feet into the air by the impulse generated by the mine. Detailed CRDL autopsy data is included in Appendix C.

The cadaver damage level was generally as shown in Figures 48 and 49 with only minor damage differences being noted for the eight boot type variations or fixture loading variations. The differences in amputation rate were not generally apparent from the post test exterior appearance of the cadavers. An indication of the improvement in exterior appearance can be obtained by comparing Figures 48 and 49 with the damage shown in Figure 27 for a non-protective boot.

The cadaver foot specimens were autopsied after the blast loading; and based on photographs, x-rays, and detailed autopsy reports, an evaluation of the damage to the foot specimens was made. This evaluation was made by five different individuals or agencies for each of the 64 tests. Thus, a total of 320 separate evaluations is available for the eight boot variations being studied.

These damage evaluations were provided by the following individuals or agencies:

Beyer, James C., M.D., Arlington Hospital,
Arlington, Virginia
Caskis, James D., M.D., Kirk Army Hospital
Aberdeen Proving Ground, Maryland
Stewart, George M., Chief, Body Armor Branch
Biophysics Division
Directorate of Medical Research
Edgewood Arsenal, Maryland
Hawkins, Clarence E., and Williams, Richard L.
Research Biologists
Edgewood Arsenal, Maryland
Kovacic, John J., M.D., Surgeon General's Office
Washington, D.C.

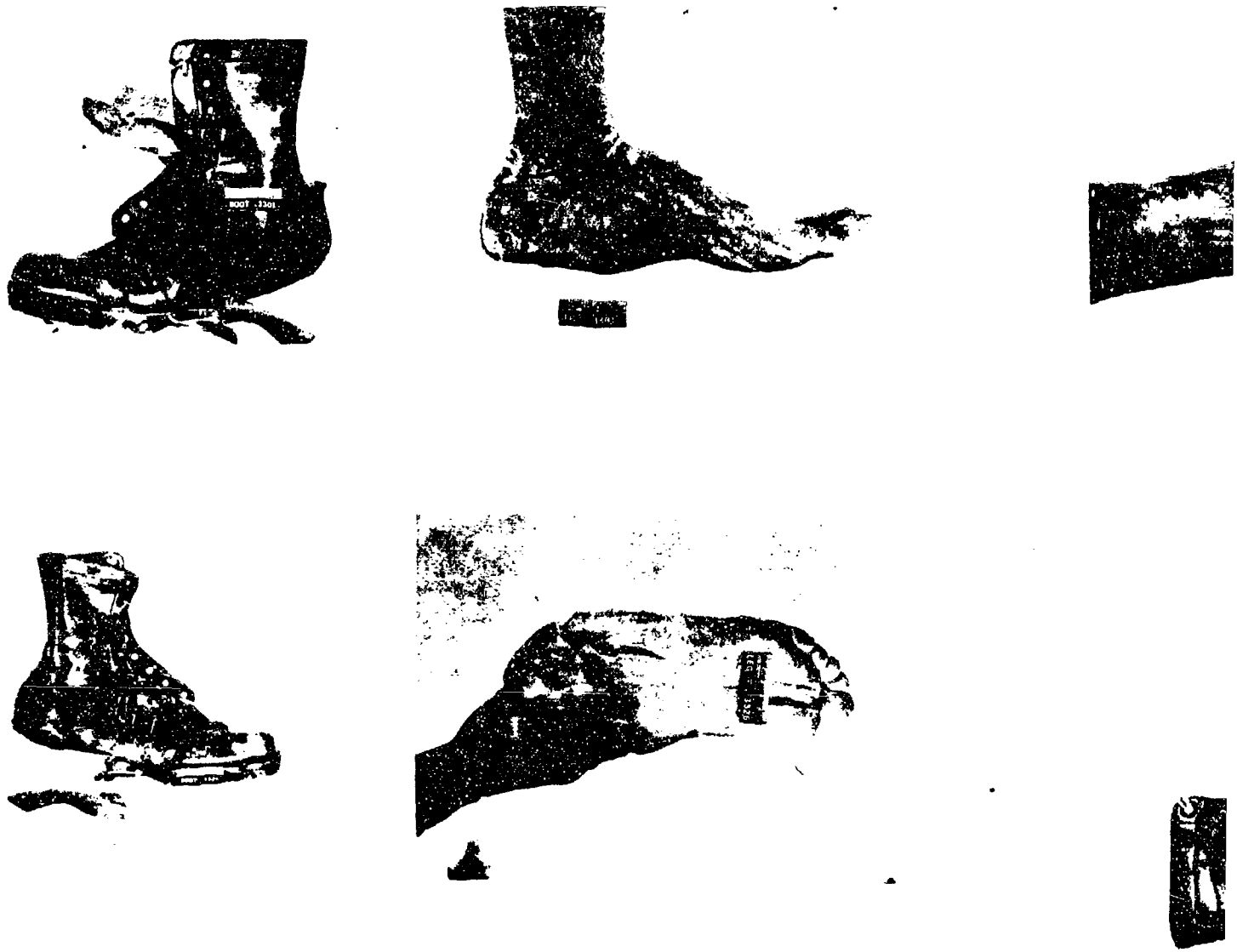

Figure 48 TYPICAL EXAMPLES OF BLAST LOADED EQUIPMENTS WITH PROTECTIVE BOOTS WITH LEATHER COATERS



FIG. 3152



FIG. 3343

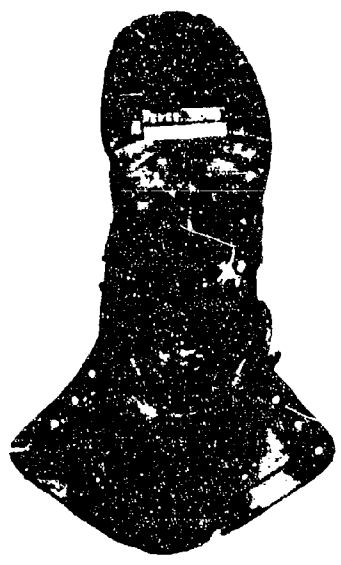

Figure 49 - TYPICAL EXAMPLES OF BLAST LOADED SPECIMENS WITH PROTECTIVE BOOTS WITH METAL COUNTERS

The damage level was broken down into four categories:

- | | |
|---------------------------------------|------------|
| 1. Definite amputation, | 1.0 points |
| 2. Marginal biased toward amputation, | 2.0 points |
| 3. Marginal biased toward salvage, | 3.0 points |
| 4. Definite salvage, | 4.0 points |

The category between 2 and 3 above (previously marginal-unbiased) was eliminated and a "grade point" number was assigned on the basis of 1.0 point for a definite amputation to 4.0 points for a definite salvage.

A summary of the foregoing data is presented in Table III. The first eight rows of data apply to the eight possible combinations of the three BOOT TYPE variables: the outsole configuration, the shank type, or the heel counter material. For example, Row 3 includes the data for all tests involving a boot with the cutaway heel (CAH) outsole, the two-piece honeycomb shank, and the leather counter. In this case, 20 out of 40 evaluations of the foot damage indicated an amputation would definitely be required. The remaining 20 evaluations indicated that there was at least a possibility that the foot might be salvageable after the proper medical treatment; thus a 50 percent possible salvage rate is indicated. The point average of 2.02 means that the average damage to the feet specimens was in the marginal range biased toward amputation.

A. Comparison between leather and metal heel counters

Rows 9 and 10 compare all of the boot specimens in terms of the effect of the counter variable. Row 9 includes all boots with leather counters irrespective of shank or outsole configuration. Row 10 includes all boots with metal counters. Thus, a comparison between Rows 9 and 10 provides a comparison between leather and metal counters. This variable was by far the most significant of the boot variables. Possible salvage was 27 percent with leather counters and 63 percent with metal counters. The point average was 1.47 with the leather counters compared to 2.40 for the metal counters. This is particularly significant in view of the fact that the 3.2 ounce stainless steel counter used for this test series represents the first attempt at a modification of the boot upper for blast protection with a potentially producible system.

The metal counter adds about 2.3 ounces to the overall weight of each boot since the leather counter weighs just under one ounce. This is a relatively small weight penalty considering the increased level of protection, but there is probably a comfort penalty associated with the metal counter. In addition, there will be an increase in the cost of boots. These cost factors are not known at the present time.

Table III
COMPOSITE AUTOPSY RESULTS OF CRDL TEST SERIES

COMPOSITE AUTOPSY RESULTS OF CRDL TEST SERIES
OF PRODUCTION TYPE BLAST PROTECTIVE BOOTS

ROW	BOOT TYPE			FOOT DAMAGE EVALUATION					PERCENT POSSIBLE SALVAGE	POINT AVERAGE
	Outsole	Shank	Counter	AMPUTATION		MARGINAL	SALVAGE			
				1.0 Points	2.0			3.0		
1	CAH	1 pc.	Leather	32	6	1	1	20%	1.27	
2	FH	1 pc.	Leather	29	4	0	0	27%	1.45	
3	CAH	2 pc.	Leather	20	4	5	5	50%	2.02	
4	FH	2 pc.	Leather	35	5	0	0	12%	1.12	
5	CAH	1 pc.	Metal	14	5	7	13	65%	2.47	
6	FH	1 pc.	Metal	15	6	5	14	62%	2.45	
7	CAH	2 pc.	Metal	14	3	10	13	65%	2.55	
8	FH	2 pc.	Metal	16	7	13	4	60%	2.12	
9	All Types	All Types	Leather	116	19	19	6	27%	1.47	
10	All Types	All Types	Metal	59	22	35	44	63%	2.40	
11	CAH	All Types	All Types	80	19	29	32	50%	2.08	
12	FULL	All Types	All Types	95	22	25	18	41%	1.79	
13	All Types	1 pc.	All Types	90	22	20	28	44%	1.91	
14	All Types	2 pc.	All Types	85	19	34	22	47%	1.96	
15	All Types	with No Load		34	7	20	19	57.5%	2.30	
16	All Types	with 160 lb. Mass		141	34	34	31	41.3%	1.81	
17	All Types			175	41	54	50	45%	1.93	

B. Comparison between outsole configurations

Rows 11 and 12 offer a direct comparison between all boots with the cutaway heel (CAH) and all boots with the full heel. The cutaway heel outsole differs from the full heel outsole in that approximately 1.5 ounces of rubber is removed from the center of the heel to provide a vent or gas relief. The cutaway heel outsole is theoretically superior in terms of decreased total impulse into the system, and this appears to be borne out by the slightly higher possible salvage rate (50 percent vs. 41 percent) and the slightly higher point average (2.08 vs. 1.79). Thus, based on protective qualities alone, the cutaway heel outsole appears to have a small advantage over the full heel outsole.

An additional benefit that is associated with the CAH outsole is the reduced total weight (1.5 ounces). The CAH outsole may also provide better traction under some conditions, but there is the possibility of catching or hooking the heel and perhaps somewhat reduced stability under certain circumstances. These details should be investigated further by a field and/or a walk and wear controlled program.

C. Comparison between the two-piece and the one-piece shanks

Rows 13 and 14 compare all boots with one-piece honeycomb shanks against all boots with the two-piece honeycomb shanks. These results are inconclusive; there is very little difference between the shank types in terms of protective capability. The two-piece shank is slightly heavier and considerably more expensive to fabricate and hence there appears to be no reason to consider the two-piece shank further.

D. Comparison between loading systems

The standard 160 pound mass which effectively restrains the cadaver system is considerably more rigid than a human upper leg and torso. For shock wave reflection, the steel structure is also high impedance causing a reflected shock wave of almost twice the peak amplitude carried in the initial wave. On the other hand, with no restraint above the cadaver lower extremity the shock wave reflection will be negative and of the same amplitude as the initial wave. If the cadaver lower extremity were attached to a human torso, there would theoretically be no significant reflected wave. This assumes a considerably oversimplified model of the human anatomy, but the overall theoretical conclusion is that a lower extremity attached to a complete torso would probably suffer less damage than either of the two extreme cases studied.

The results of the comparison between the system with the standard 160 pound mass and the system with no restraint show that there is somewhat less damage in the case of no restraint.

Rows 15 and 16 of Table III indicate the overall results of this comparison. The 16 specimens with no load restraint were uniformly distributed among the eight types of boots indicated in Rows 1 through 8.

PART VI. CONCLUSIONS AND RECOMMENDATIONS FOR PRODUCTION FOOTWEAR

The foregoing blast evaluation of the eight types of production protective DMS boots resulted in the following conclusions:

1. Considering all types of boots with leather counters, the overall possible salvage rate was 27 percent.
2. The metal counters provided a possible salvage rate more than twice as high as that of the leather counters.
3. The cutaway heel outsole is superior to the full heel by a small margin.
4. The two-piece shank is not significantly superior to the one-piece shank except by a small margin when used in conjunction with the cutaway heel outsole.
5. The unrestrained cadavers suffered less damage by a small margin than the cadavers held by the CRDL test fixture with a total mass of 160 pounds.

Other considerations which affect overall cost effectiveness can be itemized as follows:

1. The metal counter modification of the boot upper can only be considered to be a developmental item requiring additional effort to optimize design and develop production techniques.
2. The cutaway heel is about 1.5 ounces per boot lighter than the full heel.
3. The two-piece shank is considerably more expensive to fabricate than the one-piece shank: perhaps two dollars per pair in volume production.
4. Combat troops exposed to the same land mine as the cadaver test specimens will probably have a higher possible salvage rate due to their superior physical condition and also to differences between the test restraint conditions and the torso restraint conditions.

Based on these considerations, the final quantity of 70 pairs of production type DMS protective boots were fabricated as follows:

<u>Item</u>	<u>Quantity</u>	<u>Outsole</u>	<u>Shank</u>	<u>Counter</u>
1	30 pairs	Cutaway Heel	One Piece	Leather
2	30 pairs	Full Heel	One Piece	Leather
3	10 pairs	Full Heel	One Piece	Metal

70 pairs total

Of these types, it is IITRI's recommendation that Item 1 (cutaway heel, one piece, leather counter) be selected for production unless a serious deficiency is uncovered during the walk and wear evaluation. The cutaway heel provides a slightly higher level of protection as well as reduced weight.

It is also recommended that the metal counter be developed further since it offers a significantly higher level of protection than the leather counter system. This development should encompass other forms of reinforced counters as well as the stainless steel construction employed here. In addition, the footwear manufacturers should be consulted for recommendations relating to fabrication and assembly techniques, since the reinforced counter system is not directly adaptable to currently used manufacturing methods.

PART VII. DRAWINGS, SPECIFICATIONS AND COST ESTIMATES

The information which is required for an initial procurement and for planning purposes includes detailed drawings of the protective shank piece parts and boot outsoles, assembly specifications for both the shank and the boot, and cost estimates for various quantities of the shanks.

A. Drawings

Appendix A includes the detailed drawings for the one-piece honeycomb shank (IITRI Part No. 2855300) and for both the cutaway heel outsole and the full heel outsole. The shank was designed for the size 9R DMS combat boot but the changes required for other sizes will only affect the overall length and width without altering the general configuration significantly. The overall shank thickness can remain the same for all sizes since the outsole thickness remains the same for all sizes.

The two outsole drawings are based on the QMR&E drawing 04-2-1-603 dated 12 October 62. The major deviations required to incorporate the protective shank are an increased sole and heel thickness of approximately 1/16 inch and the wedge-shaped inclusion in the arch and heel region required to cover the wedge-shaped shank. Note particularly that the rubber covering the apex of the shank is continuous since any tread pattern indentations might expose the shank.

B. Specifications for fabrication

The one-piece honeycomb shank consists of three piece parts which are adhesive bonded into an assembly. The fabrication specification for the protective shank, (Part No. 2855300, Fabrication Spec. No. 2857001, Appendix B), includes the information required to fabricate the assembly. This information is in addition to the material specifications indicated on the piece part drawings.

The fabrication specification for the blast protective combat boot (Fabrication Spec. No. 2857000, Appendix B) details the required deviations from the Quartermaster Corp Limited Procurement Purchase Description for the Boot, Combat, Service Direct Molded Sole, Mildew Resistant Number LP/P DES 37-62, dated 17 October 62.

C. Cost estimates

The cost of the finished DMS protective combat boot can be separated into two parts:

1. The cost of fabricating the piece parts and adhesive bonding the shank assembly.
2. The cost of fabricating the footwear upper and molding the outsole with the shank encapsulated. This includes adhesive coating of the shank exterior.

The latter cost should be obtained from a footwear manufacturer. The cost of fabricating the shank assembly (IITRI Part No. 2855300, Appendix A) can be further broken down into the cost of each of the piece parts plus the cost of the adhesive and assembly labor. In addition, there are material handling margins which are not included here. The cost estimates for the three piece parts plus adhesive and assembly labor are indicated below. Note that only one size is being considered and a distribution among different sizes will tend to increase the costs as will the addition of any engineering costs.

ITEM No.	IITRI DRWG. No.	PART DESCRIPTION	DETAILED COST FOR QUANTITY INDICATED COST IN DOLLARS/ SHANK (NOT PAIRS)		
			10,000ea.	50,000ea.	100,000ea.
1	2855201	Casting, Wedge- Plate	\$ 3.14	3.12	3.11
2	2855301	Honeycomb, One- Piece	2.60	1.76	1.46
3	2855205	Plate, Cover	.35	.15	.10
4	Adhesive		.10	.10	.10
5	Assembly		1.00	.70	.60
TOTAL each			\$ 7.19	5.83	5.37
pair			\$14.38	11.66	10.74

The item 1 casting cost estimates are based on a quotation from Hitchner Manufacturing Co., Inc., of Milford, New Hampshire, dated 15 April 1966. A previous quotation from this same manufacturer, dated 17 September 1965, indicated a considerably lower price of \$1.88 for the quantity of 10,000 each but manufacturing problems have caused them to raise the estimate.

The item 2 honeycomb cost estimate was obtained from Hexcel Products, Inc., of Havre DeGrace, Maryland, on 19 August 1965. This is an estimate only, not a firm quotation, and based on recent experience with a purchase of raw honeycomb, it may be subject to upward revision. Although aluminum honeycomb material is generally available from a number of sources, the particular high crushing strength (4200 psi) material used in the protective shank is to our knowledge only available from Hexcel.

Item 3 is a stainless steel sheet metal part which can be obtained from any sheet metal fabricator. The cost estimate was furnished by the IITRI shop.

The item 4 adhesive cost is based on the experience with the 3M Co., EC2214 epoxy material. This is a heat curing, one component adhesive which comes in the form of a thixotropic paste. Approximately 0.01 quart was used for each shank including waste. This comes to approximately 0.10 each based on a cost of \$9.00 per gallon in 5-gallon pail lots. Liquid adhesives will probably be somewhat more economical in quantity used, and in the case of the Resiweld 7004 adhesive from H. B. Fuller Company, is somewhat lower in cost than the EC2214.

The item 5 assembly cost estimate assumes a somewhat more efficient technique than the hand layup method employed by IITRI for the small quantity production. The assembly cost includes cleaning of parts and any necessary mechanical roughing or sandblasting but does not include external coating of the shank. The external coating must be done shortly prior to molding the footwear outsole and is the responsibility of the footwear manufacturer.

Reviewing the cost breakdown indicated in the table, it is clear that the major costs rest with items 1 and 2. A value analysis program to reduce these piece part costs should result in a considerable saving. To illustrate, the H.M. Harper Co., of Morton Grove, Illinois, indicates that item 1 may be reduced to \$1.00 each in 50,000 piece quantities if an impact forging technique can be successfully applied. This would involve an experimental effort with an estimated 75 to 85 percent probability of success.

Item 2, the honeycomb, involves approximately 0.064 pounds of material including aluminum foil and adhesives. At an estimated cost of \$1.46 each in quantities of 100,000 each, the finished piece parts cost approximately \$22.00 per pound. Some consideration might be given to producing the finished part directly from foil rather than from pre-corrugated honeycomb core machined to size. Alternatively, the part might be partially crushed to size from a roughed out block to reduce machining costs.

The foregoing suggestions for cost reduction by no means exhaust the possibilities. If a large quantity procurement is anticipated, it is recommended that a value analysis program precede the procurement.

References

1. MacDonald, J.L., and Fujinaka, E.S., Development of Optimum Foot Protection Against Antipersonnel Mines Using A Supplementary Device, Interim Report No. E6029-2, IIT Research Institute, Chicago, Illinois, DA 19-129-QMC-379(N) (March 16, 1965).
2. Fujinaka, E.S., and MacDonald, J.L., Damage Threshold For An Impulsively Loaded Human Foot, IITRI Report No. E249-2A, Supplement A to Final Report IITRI No. E0249-2, IIT Research Institute, Chicago, Illinois, DA 49-193-MD-2247 (December 15, 1964).
3. Fujinaka, E.S., Development of Optimum Foot Protection Against Antipersonnel Mines Using A Supplementary Device, Phase I Report No. E6029-5, IIT Research Institute, Chicago, Illinois, DA 19-129-QMC-379(N) (March 15, 1960).
4. Heaton, Lt. Gen. L.D., Coates, Col. J.B., and Beyer, Major. J.C., Wound Ballistics., Office of the Surgeon General, Department of the Army, Washington, D.C. (1962).
5. Holmes, Col. Robert H., et al. Preliminary Evaluation of the Experimental Shank Direct Molded Sole Boot Against the M-14 Land Mine, CWL Technical Memorandum 21-3, Biophysics Division, U. S. Army Chemical Warfare Laboratories, (April 1960).
6. Stewart, G.M., Beyer, J.C., and Hawkin, C.E., Combat Troops Versus Anti-Personnel Mine Part I: Evaluation of Experimental Shank, Direct-Molded-Sole Combat Boot Against M-14 APERS Mine, CRDL 3154, Edgewood Arsenal, Maryland (December 1962).
7. Stewart, George M., Untitled, Unpublished Preliminary Data on the Blast Effect of Various Charge Sizes and Configuration Against Human Lower Extremities, Body Armor Branch, Biophysics Division, Directorate of Medical Research, U.S. Army Chemical Research and Development Laboratory.

26 September 1962	(Letter)
5 September 1962	(Letter)
9 August 1962	(Letter)
27 June 1962	(Letter)
7 June 1962	(Letter)
18 May 1962	(Letter)
27 March 1962	(Data Notes)
13 August 1963	(Data Notes)
13 September 1965	(Letter)
4 November 1965	(Letter)
8 December 1965	(letter)
8. Dept. of Army, Tech. Manual No.9-1940, Land Mines, (May 1956).

APPENDIX A
DRAWINGS

NOTES:
 1. LINES MAY OVER SIZE OF SURFACE
 2. 1/16" INCH MAX BEZELUS PERMITTED AT ALL CORNERS

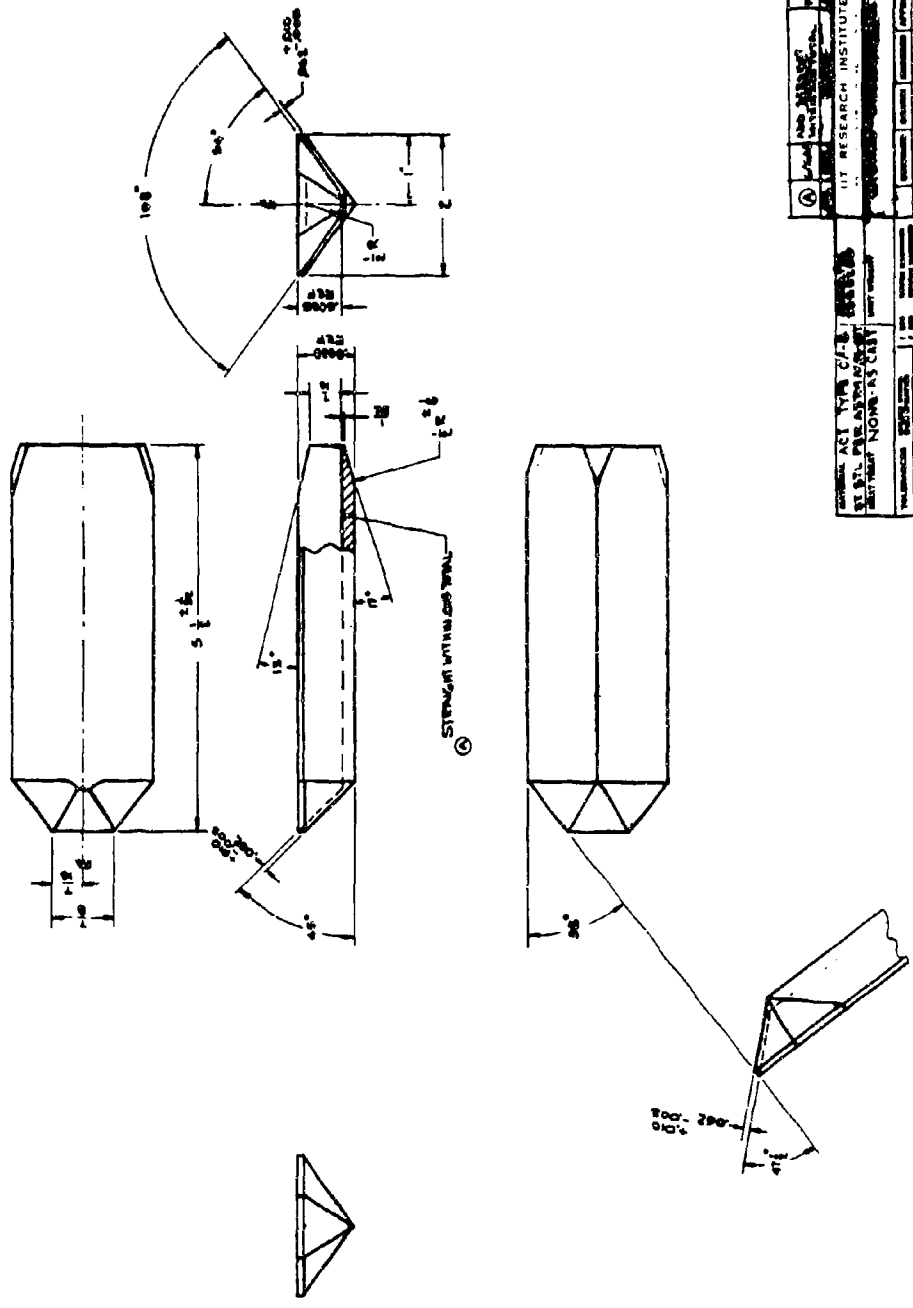

PROJECT NO.	342894708
DATE	11/15/54
DESIGNER	J. R. BROWN
CHECKED	J. R. BROWN
APPROVED	J. R. BROWN
SCALE	AS SHOWN
LIT RESEARCH INSTITUTE	
1000 UNIVERSITY AVENUE	
ANN ARBOR, MICHIGAN	
PRODUCT NO. E276	
DRAWING NO. 10000000	

SIMILAR TO 342894708

ITEM	PART NO.	DESCRIPTION	QTY.
1	ZASS205	PLATE, COVER	1
2	ZASS201	CASTING, WEDGE PLATE	1
3	ZASS301	HONEYCOMB, ONE PIECE	1

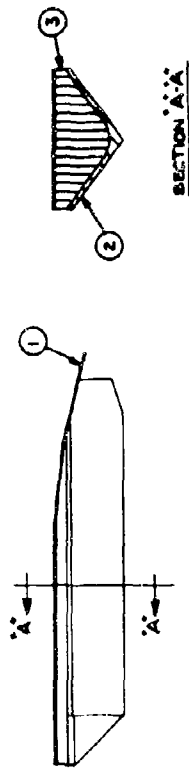

REV.	DATE	DESCRIPTION	BY
IIT RESEARCH INSTITUTE TECHNOLOGY CENTER CHICAGO, ILLINOIS 60618			
PROTECTIVE SHANK - ONE PIECE			
SCALE	AS SHOWN	DATE	
PLAT		BY	
APPROVED		DATE	
2855 300			

NOTES:
 1) DIMENSIONS INDICATED ARE FOR EXTERNAL ENVELOPE; IMPERFECT CELLS PERMITTED AT EDGES
 2) CELLS TO BE ORIENTED WITH AXIS VERTICAL WITHIN $\pm 2^\circ$

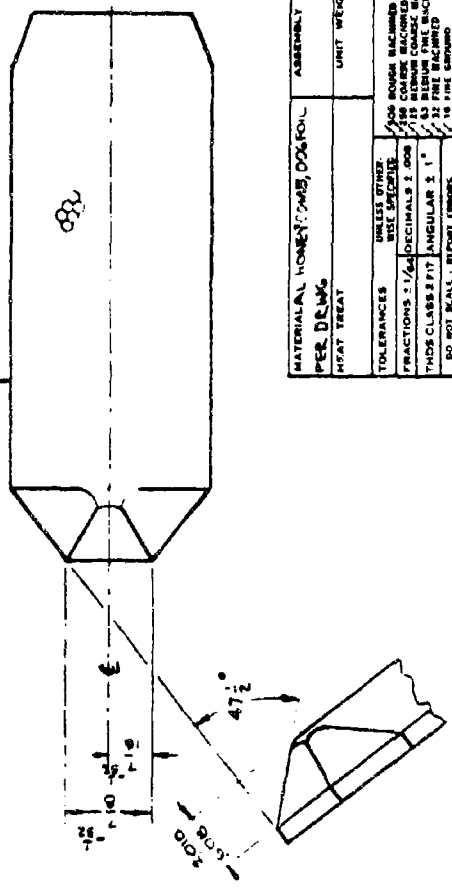
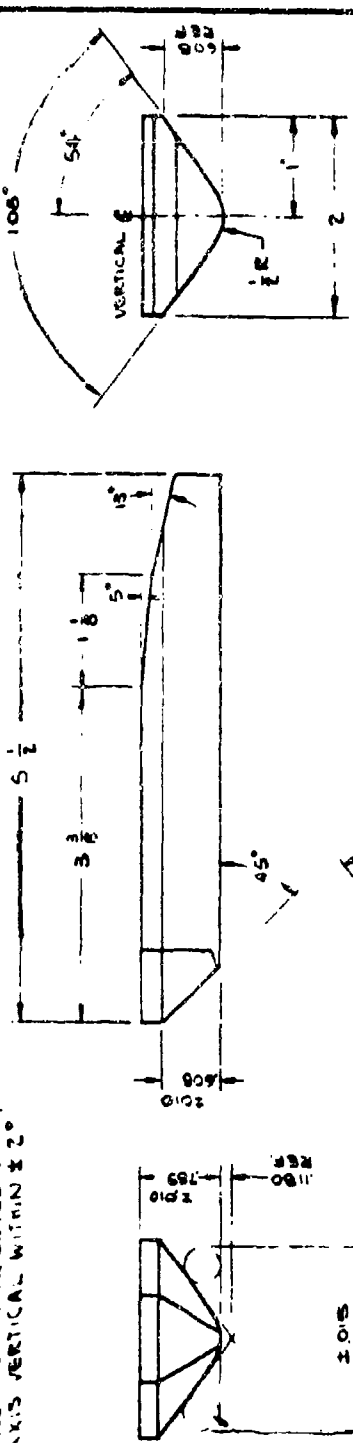

MATERIAL: HONEYCOMB, DOK FOIL	ASSEMBLY NO
PER DRUM	UNIT WEIGHT
HEAT TREAT	
TOLERANCES	UNLESS OTHER SPECIFIED
FRACTIONS: 1/4	DECIMALS: 2 .005
THIS CLASS: FIT ANGULAR: 1°	
DO NOT BEND BEYOND CORNER	
BREAK ALL SHARP CORNERS	
CRIMP ALL TAPERED HOLES 1/2 IN 2 45° REMOVE BURRS	
	FOR SOURCE REVISIONS
	1.00 INCHES
	1.18 INCHES
	AS BURNED FILE BURNISHED
	2.00 INCHES
	1.00 INCHES
	1.00 INCHES
	1.00 INCHES

DATE	DESCRIPTION OF WORK	BY
	III RESEARCH INSTITUTE	
	TECHNOLOGY CENTER	
	CHICAGO, ILLINOIS 60618	
	HONEYCOMB	
	ONE PIECE	
SCALE		
FIG. NO.		
REV.		
DATE		
BY		
CHKD.		
APP. BY		
DATE		
	7853101	

LAST REFERENCE NO. US MIL'S
 SIZE RANGE 4-18
 LATHE MODEL SIZES 9
 GIVE 5 LBS. GRADED FROM MODEL
 SPEC. GRADE OF LAST BOTTOM PATTERNS. O POINTS GEOMETRIC
 IMPORTANT: INSOLE & BUCKER SHAPES MUST BE IDENTICAL WITH
 HEIGHT OF LAST 11 INCHES. LAST HEATING NOT REQUIRED

SIZE	4	5	6	7	8	9	10	11	12	13	14	15
SOLE WIDTH	4 1/2	4 7/8	5 1/8	5 5/8	6 1/8	6 5/8	7 1/8	7 5/8	8 1/8	8 5/8	9 1/8	9 5/8
HEEL WIDTH	4 1/2	4 7/8	5 1/8	5 5/8	6 1/8	6 5/8	7 1/8	7 5/8	8 1/8	8 5/8	9 1/8	9 5/8
HEEL HEIGHT	1 1/2	1 1/2	1 1/2	1 1/2	1 1/2	1 1/2	1 1/2	1 1/2	1 1/2	1 1/2	1 1/2	1 1/2
HEEL WIDTH AT HEEL SCOPING	4 1/2	4 7/8	5 1/8	5 5/8	6 1/8	6 5/8	7 1/8	7 5/8	8 1/8	8 5/8	9 1/8	9 5/8
HEEL WIDTH AT FORE PART	4 1/2	4 7/8	5 1/8	5 5/8	6 1/8	6 5/8	7 1/8	7 5/8	8 1/8	8 5/8	9 1/8	9 5/8
HEEL WIDTH AT COUNTER	4 1/2	4 7/8	5 1/8	5 5/8	6 1/8	6 5/8	7 1/8	7 5/8	8 1/8	8 5/8	9 1/8	9 5/8
HEEL WIDTH AT TOE	4 1/2	4 7/8	5 1/8	5 5/8	6 1/8	6 5/8	7 1/8	7 5/8	8 1/8	8 5/8	9 1/8	9 5/8

CURVATURE OF SOLE BOTTOM
 STANDARD PRACTICE IS TO
 ALLOW SOLE BOTTOM TO
 CONFORM TO CURVATURE
 OF LAST BOTTOM

SOLE & HEEL SUBSTANCE - SEE DIAGRAM

SOLE WIDTH AT HEEL	4	5	6	7	8	9	10	11	12	13	14	15
SOLE M	1/2	1/2	1/2	1/2	1/2	1/2	1/2	1/2	1/2	1/2	1/2	1/2
HEEL HEIGHT	1 1/2	1 1/2	1 1/2	1 1/2	1 1/2	1 1/2	1 1/2	1 1/2	1 1/2	1 1/2	1 1/2	1 1/2
HEEL WIDTH AT HEEL SCOPING	4 1/2	4 7/8	5 1/8	5 5/8	6 1/8	6 5/8	7 1/8	7 5/8	8 1/8	8 5/8	9 1/8	9 5/8
HEEL WIDTH AT FORE PART	4 1/2	4 7/8	5 1/8	5 5/8	6 1/8	6 5/8	7 1/8	7 5/8	8 1/8	8 5/8	9 1/8	9 5/8
HEEL WIDTH AT COUNTER	4 1/2	4 7/8	5 1/8	5 5/8	6 1/8	6 5/8	7 1/8	7 5/8	8 1/8	8 5/8	9 1/8	9 5/8
HEEL WIDTH AT TOE	4 1/2	4 7/8	5 1/8	5 5/8	6 1/8	6 5/8	7 1/8	7 5/8	8 1/8	8 5/8	9 1/8	9 5/8

SOLE WIDTHS ARE MEASURED TIGHT AGAINST UPPER
 DIM'S GIVEN SCOURING WHERE WELT WIDTHS VARY
 NORMAL PRACTICE IS TO ALLOW THE CHANGE
 OF WELT WIDTHS TO OCCUR AT THE END OF THE PATTERNS AND
 AT HEEL BREADTH IF WELT VARIES FROM WAIST
 TO SEAT DETAILS MUST BE GIVEN IF DESIGN
 DIFFERS FROM ABOVE

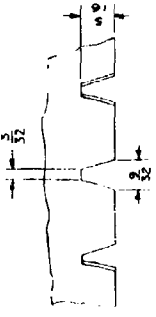
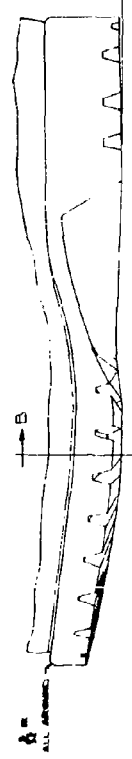
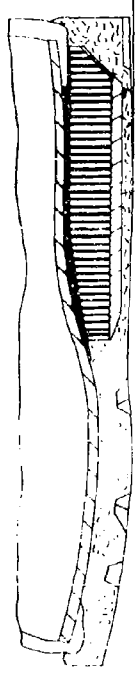
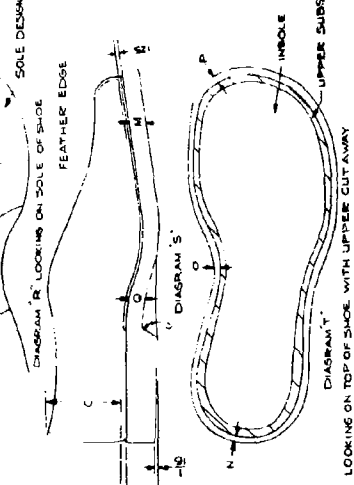
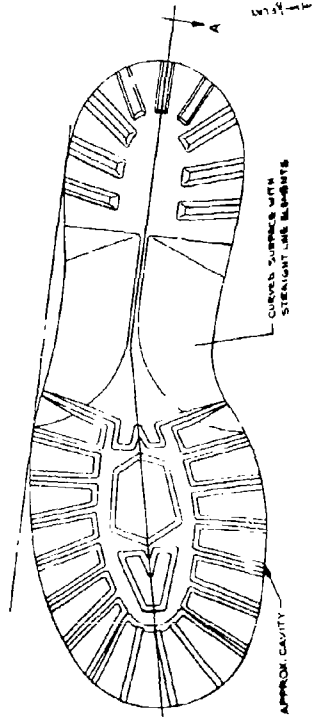

U.S. MILITARY RESEARCH INSTITUTE
 FOOTWEAR CENTER
 DIRECT MOLDING OUTSOLE DESIGN
 FULL HEEL

DATE: 10/15/50
 DRAWN BY: [blank]
 CHECKED BY: [blank]
 APPROVED BY: [blank]

LAST: DESIGN DETAILS
 REFERENCE NO. US MIL'S
 SIZE RANGE 4-18
 LATHE MODEL SIZES 9
 GIVE 5 LBS. GRADED FROM MODEL

LAST: REFERENCE NO. U.S. MIL-5
 SIZE RANGE 4-15
 LAST TYPE 150
 GAVE SIZES GRABBED FROM MODEL
 SPECIFY SHINER W-WY BOTTOM PATTERNS TO POINT GEOMETRIC
 INSOLE AND SOLE BACKER SHAPES MUST BE IDENTICAL WITH
 LAST BOTTOM SHAPES
 HEIGHT OF LAST 11 INCHES LAST HEATING NOT REQUIRED

SIZE	4	5	6	7	8	9	10	11	12	13	14	15
SOLE LENGTH	10.5	11.0	11.5	12.0	12.5	13.0	13.5	14.0	14.5	15.0	15.5	16.0
SOLE WIDTH	4.5	4.8	5.0	5.3	5.6	5.9	6.2	6.5	6.8	7.1	7.4	7.7
HEEL HEIGHT	1.2	1.2	1.2	1.2	1.2	1.2	1.2	1.2	1.2	1.2	1.2	1.2
HEEL WIDTH	1.5	1.5	1.5	1.5	1.5	1.5	1.5	1.5	1.5	1.5	1.5	1.5
HEEL SHARPEN	0.5	0.5	0.5	0.5	0.5	0.5	0.5	0.5	0.5	0.5	0.5	0.5
HEEL RADIUS	0.5	0.5	0.5	0.5	0.5	0.5	0.5	0.5	0.5	0.5	0.5	0.5
HEEL FLARE	0.5	0.5	0.5	0.5	0.5	0.5	0.5	0.5	0.5	0.5	0.5	0.5
HEEL ANGLE	15	15	15	15	15	15	15	15	15	15	15	15
HEEL STRENGTH	100	100	100	100	100	100	100	100	100	100	100	100
HEEL WEAR	100	100	100	100	100	100	100	100	100	100	100	100
HEEL LIFE	100	100	100	100	100	100	100	100	100	100	100	100
HEEL COST	100	100	100	100	100	100	100	100	100	100	100	100

CURVATURE OF SOLE BOTTOM
 STANDARD PRACTICE IS TO
 COMPARE TO BOTTOM TO
 OF THE LAST BOTTOM

SOLE (HEEL SUBSTANCE) - SEE DIAGRAMS

SOLE SUBSTANCE	1	2	3	4	5	6	7	8	9	10	11	12	13	14	15
SOLE M															
SOLE N															
SOLE O															
SOLE P															
SOLE Q															
SOLE R															
SOLE S															
SOLE T															
SOLE U															
SOLE V															
SOLE W															
SOLE X															
SOLE Y															
SOLE Z															

SOLE WIDTHS ARE MEASURED "TIGHT AGAINST"
 UPPER DRUM GIVEN ROOMING TO POINT ON THE
 CHANGE TO TAKE PLACE BETWEEN FOREFOOT
 AND HEEL BREAST IF WELT VARIES FROM
 WELT TO WELT DETAILS MUST BE GIVEN
 IF DESIGN PATTERNS FROM ABOVE

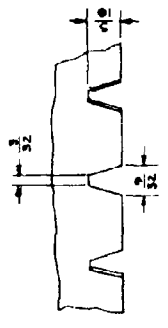
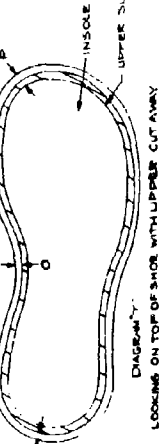
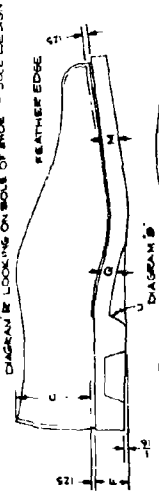
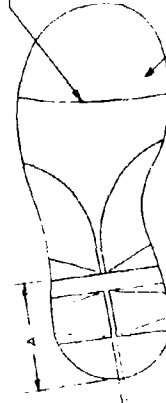

DETAIL OF CLEATS
 SCALE 2:1

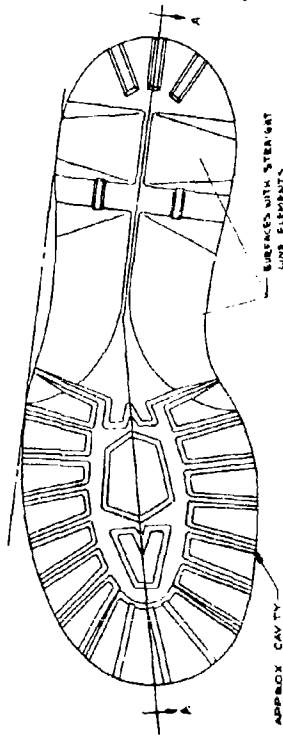

APPROX. CAVITY

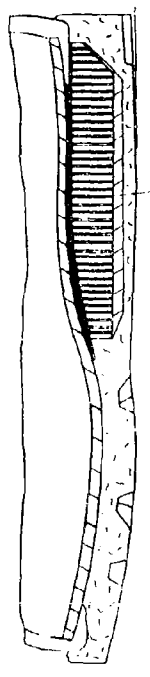

SECTION AA

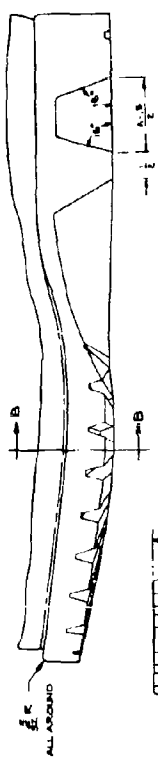

SECTION BB

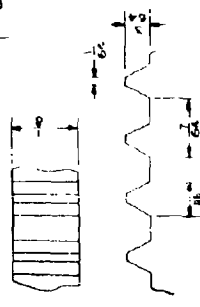

FITTING THE DETAIL
 PITCH
 FROM HEEL BREAST TO HEEL BREAST
 SCALE 2:1

NO. 157	RESEARCH INSTITUTE	2272
NO. 158	RESEARCH INSTITUTE	2272
NO. 159	RESEARCH INSTITUTE	2272
NO. 160	RESEARCH INSTITUTE	2272
NO. 161	RESEARCH INSTITUTE	2272
NO. 162	RESEARCH INSTITUTE	2272
NO. 163	RESEARCH INSTITUTE	2272
NO. 164	RESEARCH INSTITUTE	2272
NO. 165	RESEARCH INSTITUTE	2272
NO. 166	RESEARCH INSTITUTE	2272
NO. 167	RESEARCH INSTITUTE	2272
NO. 168	RESEARCH INSTITUTE	2272
NO. 169	RESEARCH INSTITUTE	2272
NO. 170	RESEARCH INSTITUTE	2272
NO. 171	RESEARCH INSTITUTE	2272
NO. 172	RESEARCH INSTITUTE	2272
NO. 173	RESEARCH INSTITUTE	2272
NO. 174	RESEARCH INSTITUTE	2272
NO. 175	RESEARCH INSTITUTE	2272
NO. 176	RESEARCH INSTITUTE	2272
NO. 177	RESEARCH INSTITUTE	2272
NO. 178	RESEARCH INSTITUTE	2272
NO. 179	RESEARCH INSTITUTE	2272
NO. 180	RESEARCH INSTITUTE	2272

IITRI FABRICATION
SPEC. NO. 2857001

FABRICATION SPECIFICATION FOR THE PROTECTIVE SHANK, PART
No. 2855300

The Protective Shank, part number 2855300, shall be fabricated as an adhesive bonded assembly from the three piece parts indicated on the assembly bill of materials. In addition to the information supplied on the respective drawings, the piece parts must meet the following minimum specification:

A. Plate, Cover. IITRI Part No. 2855205

The surface which is to be next to the honeycomb shall be prepared for adhesive bonding per MIL-A-9067C paragraph 6.1.2 or an equivalent mechanical roughing method such as sand or grit blasting with a solvent wash.

B. Honeycomb, One Piece. IITRI Part No. 2855301

The aluminum honeycomb material must be fabricated to MIL-C-7438C where applicable. The foil material is to be .006 inch thick nominal 5052-H39 alloy. The nominal cell size is 1/8 inch hexagonal configuration, pre-corrugated. The average axial crushing strength of the core material is to be 4200 ± 200 psi over the range of plastic deformation from 25% to 65% of the initial thickness. The gross density of the core material is to be $22 \text{ lbs/ft}^3 \pm 15\%$.

One suggested suitable material which meets this specification is available from the following source:

Hexcel Products, Incorporated
2332 Fourth Street
Berkeley, California
Material Part No. 1/8-5052-006

C. Casting-Wedge Plate. IITRI Part No. 2855201

Fabricate as an investment casting per detailed drawing.

D. Adhesive For Assembly Of Part 2855300

An epoxy adhesive is to be uniformly applied to the surface of the casting, IITRI Part No. 2855201, and to the surface of the plate, IITRI Part No. 2855301. The adhesive surface preparation and assembly technique shall be sufficient to provide for the integrity of the completed assembly during normal handling and during the cure cycle required for the molded rubber outsole (300°F to 325°F for approximately 20 minutes).

MIL-A-9067C, Adhesive, Bonding, Process and Inspection Requirements for, or its equivalent shall be used as a guide where applicable. The adhesive itself must meet the requirements of MIL-A-25463 (ASG), Type 1, Class #1, Adhesive, Metallic Structural Sandwich Construction, unless specifically excepted.

In addition, the following two epoxy adhesives which have not been approved under MIL-A-25463 shall also be acceptable:

1. Scotchweld EC-2214 one component, heat curing, thixotropic paste, adhesive available from:

3M Company
2501 Hardston Road
St. Paul 19, Minn.

2. Resiweld 7004, two component, liquid room temperature curing adhesive available from:

H. B. Fuller Company
255 Eagle Street
St. Paul 2, Minn.

Additional adhesives which do not meet the requirements of MIL-A-25463 may be approved at the option of the QM Corp.

E. Coating For Assembly 2855300

The adhesive bonded assembly is to be sand blasted all over and coated uniformly with a synthetic rubber-resin solvent type adhesive which meets the requirements of MIL-C-4003. This coating is to be applied within 48 hours prior to direct molding into the boot assembly (See IITRI Fabrication Specification No. 2857000). One suggested suitable material which meets this specification is available from the following source:

BB Chemical Division
United Shoe Machinery Corporation
748 Memorial Drive
Cambridge, Massachusetts

Part No. BOSTIK 4034

IITRI FABRICATION
SPEC. NO. 2857000

FABRICATION SPECIFICATION FOR THE BLAST PROTECTIVE COMBAT BOOT

The direct molded sole (DMS) Protective Combat Boot is to be fabricated in accordance with the Quartermaster Corps Limited Procurement Purchase Description for the Boot, Combat, Service, Direct Molded Sole, Mildew Resistant Number LP/P. DES 37-62 dated 17 October 62. The only exceptions to the aforementioned Purchase Description are those required to incorporate the protective shank (IITRI Part No. 2855300) in place of the Steel Shank described in paragraph 3.2.3.1.

Incorporation of the protective shank will require the following major deviations from the aforementioned Purchase Description:

A. Counter Pocket (reference paragraph 3.2.1.1.5)

The counter pocket shall be made from patterns supplied by the QM Corps with allowance for lasting over the protective shank for at least 1/4 x 1 inch overlap on each side of the forward portion of the shank. Lacing the counter pocket across the shank shall be used to hold the counter pocket in place during the cure cycle.

B. Bottom Design (reference paragraph 3.2.4.2.1)

IITRI drawing 2856000 or 2856001, as specified by the Contacting Officer, shall be used in place of Figure 1 to determine the outsole configuration.

C. Heel Fillers (reference paragraph 3.2.6.1)

No heel filler is required.

D. Steel Shank (reference paragraph 3.2.3.1)

The Protective Shank, IITRI part number 2855300, shall be used in place of the steel shank described in paragraph 3.2.3.1. Fabrication of the Protective Shank is detailed in IITRI Fabrication Specification No. 28557001. Note that the final external coating applied to the shank must be performed within 48 hours of the molding of the outsole.

E. Sole and Heel Molding (reference paragraph 3.6.15)

The dwell time at 300-325°F must be adequate to insure proper adhesion of the rubber to the leather. This may require a twenty-five (25) minute dwell time with an optional rubber biscuit preheat to not more than 150°F being permissible.

APPENDIX C

CRDL AUTOPSY REPORTS ON DAMAGE TO CADAVER LOWER EXTREMITIES

APPENDIX C

AUTOPSY REPORTS ON DAMAGE TO CADAVER LOWER EXTREMITIES

The following autopsy reports describe the damage inflicted to a human cadaver lower extremity during impulsive loading with an M-14 land mine. Some form of protective footwear was worn in all cases as described in the main text of this report.

The U. S. Army Chemical Research and Development Command provided the information contained in these autopsy reports. They also obtained the medical judgments of the relative severity of the injury. These medical judgments are summarized elsewhere in this report.

Table C1

CRDL AUTOPSY REPORTS ON CONCEPT A CADAVER LOWER EXTREMITIES

CRDL Number	ITRI Number	Footwear Description	CRDL AUTOPSY DESCRIPTION
3137	1	Type A, multiple piece 15/16x2x6"	There is a laceration of the lateral malleolus extending 5.5 cm. upward from the sole. The laceration measures .9 cm. at its widest point. There is a laceration on the medial aspect of the foot extending upward from the sole 6.1 cm. and measures 2.5 cm. at its widest point. The calcaneus is severely comminuted into many bony fragments. The only major piece found measures 5 cm. long by 2 cm. wide. The talus is fractured into two major pieces about equal in size. There are fractures of the 4th and 5th metatarsals. There are no other fractures.
3138	2	Same as above	There is a laceration on the lateral aspect of the foot extending 6.5 cm. upward from the heel, measuring 1.9 cm. at its widest point. There is a laceration of the skin only on the medial aspect of the foot measuring 3.6 cm. in length and .5 cm. at its widest point. There is severe comminution of the calcaneus into many bony fragments. The navicular is fractured into 2 major pieces. The tibia is intact. The cuboid is severely comminuted. The 1st, 2nd and 3rd cuneiforms are severely comminuted. There are fractures of the 4th and 5th metatarsals. The 5th is severely comminuted along its entire length. There are no other fractures.
3139	3	Same as above	A 10 cm. laceration just to medial side of midline on plantar surface, beginning just distal to ball of foot. This laceration measures 2.5 cm. at widest point. About halfway along its length 2-1/2 cm. laceration comes off at right angles. A 16 cm. (deep) laceration begins on medial side over achilles, 8.5 cm. above plantar surface of heel and extends obliquely around to medial surface, lateral side. Another laceration, beginning 7 cm. above plantar surface and 7.5 cm. in front of heel extends into massive trauma on plantar surface. Skin peeled from underlying tissue beginning approximately 20 cm. up the leg from sole and extends over heel to arch dorsally. Massive plantar trauma area (15 x 9 cm.) in heel and arch. This trauma consists of extensive soft tissue and bone mutilation. The calcaneus is completely destroyed and all but the distal 1/3 of talus. The navicular is partially comminuted over a small area of the medial plantar aspect. The cuboid is fractured vertically through the midline with lateral bone comminution. Plantar edge of articular face of the 4th metatarsal is fractured along its axis for a distance of approximately 2.5 cm., ending on plantar surface (3 or 4 small pieces). Heads of both tibia and fibula are both severely comminuted. This fracturing extends for 3 to 4 cm. up shafts. A couple lacerations on medial side of foot extending vertically from plantar edge for 6 to 7 cm. up over ankle. No further damage. Possible lower leg amputation.
3140	4	Same as above with additional layer of 1/8" rubber	A 5 cm. laceration beginning 4 cm. from back of heel and 1 cm. from plantar edge extends obliquely, ending just in front of lateral malleolus. Similar skin wound at same location on medial surface is 7 cm. long. Calcaneus severely comminuted with the largest piece 5 x 3 x 2 cm. at astragalus junction. Navicular comminuted on plantar half, as well as the cuboid. The 1st, 2nd and 3rd cuneiforms are moderately comminuted. The 3rd metatarsal is slightly comminuted into 3 major pieces from its cuneiform articulation extending 3.5 cm. distally. The 5th metatarsal is fractured just proximal to its phalangeal articular head. The talus has a vertical thru-and-thru (176 size of talus) fracture of the dorso-medial edge just behind the malleolus. There is also chip fracturing of the dorsal surface at the roband navicular articulation. Talus otherwise intact. Slight chip fracturing of lateral head of fibula. Possible amputation.

Table C2

CRDL AUTOPSY REPORTS ON CONCEPT B. CADAVER LOWER EXTREMITIES

CRDL Number	INTRI Number	Footwear Description	CRDL AUTOPSY DESCRIPTION
3142	6	Type B, single piece 15/10x26"	There is a gaping wound extending 16 x 8 cm. at its widest point with 3 radiating cracks: (1) 5 cm. (2) 2.6 cm. (3) 8 cm. long x 3.2 cm. wide at its widest point. There is a laceration on the medial aspect of the foot extending 7 cm. upward from the heel. The calcaneus is severely comminuted into many bony fragments. The navicular is broken into 2 major pieces. The cuboid is broken into many bony fragments. There are comminuted fractures of the 1st, 2nd and 3rd cuneiforms. The talus is intact. There are no other fractures.
3143	8	Same as above	There is a gaping laceration on the plantar surface extending 13 cm. from the heel. There is a laceration on the lateral aspect of the foot extending 8 cm. upwards from the heel. It measures 2.1 cm. at its widest point. There is a skin laceration on the medial aspect of the foot measuring 4.0 cm. long x 1.2 cm. at its widest point. There is a severe comminution of the calcaneus into many bony fragments. The talus is fractured into 3 major pieces, all about equal in size. The navicular is comminuted with only 1 major piece remaining. The cuboid is fractured into 2 equal major pieces. The 1st, 2nd and 3rd cuneiform bones are comminuted into many bony fragments. There are no other fractures.
3144	9	Same as above	A 17 cm. long laceration running longitudinally on plantar surface beginning 1.5 cm. from medial edge and about 1 cm. distal to ball. It progresses obliquely to midline winding up in heel. This deep wound is 5.5 cm. at widest part in heel. A 7.5 cm. vertical deep laceration on medial side from the malleolus to plantar edge. A right angle laceration on the lateral aspect of foot with its horizontal leg pointed towards heel. This wound begins 5 cm. distal to malleolus and its vertical leg is 5 cm. with a 4.5 cm. remainder winding up at plantar surface. Calcaneus extensively comminuted with only 4 major pieces remaining. The talus is comminuted into 3 or 4 pieces on medial half of its proximal articulation with the tibia and its malleolus. Also the proximal plantar edge of this bone is chip fractured. Plantar edge of 2nd cuneiform chip fractured. Chip fracturing of the plantar and medial faces of 1st cuneiform and plantar surface of head of 1st metatarsal. Chip fracturing of these faces of 3rd, 4th and 5th metatarsal heads. A simple break of 3rd, 4th and 5th metatarsals, just proximal to their phalangeal head. A couple of cracks on the articular head of the tibia. Possible save.
3145	10	Same as above with additional layer of 1/2" low density foam	A 7 cm. longitudinal laceration on plantar surface just medial to midline. Also a 7.5 cm. vertical laceration on medial side beginning just above malleolus and ending after 8 cm. at plantar edge. This wound is 4 cm. at widest part. The plantar wound is 1 cm. at its widest point. Skin is peeled from leg beginning about 15 cm. above the malleoli and extends to plantar surface of heel and to the toes on dorsal surface. A curving laceration beginning at the lateral malleolus and curving gently backward towards heel, ends within about 2 cm. of the plantar edge and 1 cm. from back of heel. The total length of this wound is 3 cm. Another oblique laceration 3 cm. in length over achilles begins 2.5 cm. from plantar heel. Upon dissection it is found that the calcaneus is severely comminuted with largest remaining piece 5 x 2 x 2 cm. The talus is severely chip fractured on the lateral facet at the malleolus. The navicular is comminuted into about 4 pieces. The cuboid is chip fractured on its medial articular border and its lateral border. The 3rd cuneiform has fractures on plantar edge and the dorsal edge of its articulation with the navicular. The 3rd and 5th metatarsal heads are chip fractured. The tibia and fibula are extensively comminuted from heads up shafts to 5 cm. of fibula and 7 cm. of tibia. Possible lower leg amputation.

CRDL AUTOPSY REPORTS ON CONCEPT C. CADAVER LOWER EXTREMITIES

CRDL Number	IITRI Number	Footwear Description		CRDL AUTOPSY DESCRIPTION
		Shank Dimensions	Upper Honeycomb Density, lb/ft ³	
3149	1	1-1/16x2x6"	23.1	There is no soft tissue damage. The calcaneus is comminuted severely with one major piece remaining which measures 6 x 4 x 3 cm. The talus is intact, no damage. The navicular and cuboid bones are completely comminuted. The 3rd cuneiform bone is severely fractured on the plantar surface and the articular surface with the cuboid. The 2nd cuneiform has a mild chip fracture on its plantar apex. The lateral aspect of the head of the 5th metatarsal has a chip fracture as well as the medial aspect of the head of the 3rd metatarsal. With the proper medical treatment and therapy it is anticipated that an amputation would not be required.
3150	2	1-1/16x2x6"	19.2	There is a laceration of the skin only, not a deep wound, running from the instep toward the toes measuring 15.5 cm. in length by 3 cms. at its widest point. There is a skin laceration on the medial aspect of the heel measuring 5 cm. long by 1.8 cm. at its widest point. This is also a minor skin laceration. There is a laceration of the lateral aspect of the heel measuring 4.6 cm. x 1.5 cm. at its widest point. There is a chip fracture of the tibia where it articulates with the talus. The chipped bone measures 2.5 cm. x 3.9 cm. x 1.9 cm. There is a fracture of the fibula occurring 7 cms. upward from the articular head. This is a complete fracture. There are several minor chip fractures on the head of the fibula. The calcaneus is comminuted however there remains one major piece surrounded by bony fragments. This major piece measures 5 x 4 x 3.2 cm. The talus is fractured into 2 pieces of equal size. The cuboid is undamaged. There is a minor chip fracture of the navicular bone. There are fractures of the 4th and 5th metatarsals with the 5th metatarsal having a complete fracture and the 4th having a fracture at the articular head. With proper medical treatment and therapy it is anticipated that an amputation would not be required.
3151	4	1-1/16x2x6"	15.3	There are two minor epidermal lacerations on the arch. A large laceration on the lateral surface beginning 1.5 cm. from the plantar surface and 6.0 cm. posterior from the small toe running obliquely towards the malleolus for 8 cm. at its widest point it measures 2.5 cm. The calcaneus is comminuted, one major proximal piece measuring 6.0 x 5.0 x 2.8 cm. There is a chip fracture at the talus on its posterior plantar surface and on the medial edge at the ball joint. The cuboid is severely comminuted. The navicular has a chip fracture on its plantar surface. The 1st, 2nd and 3rd cuneiform bones are badly fractured on their plantar surfaces. The 2nd, 3rd, 4th and 5th metatarsals are severely fractured at their articulation with the cuneiform bones and the cuboid. The cuboid is comminuted. The lateral aspect of the fibula head has a severe chip fracture and the medial aspect of the tibia has a small chip fracture. Would receive medical treatment however it is anticipated that an amputation may likely be required.
3152	5	1-1/16x2x5"	15.3	There is no soft tissue damage. Dissection reveals the tibia and fibula are not damaged. The calcaneus is comminuted but one major piece remains measuring 5.0 x 4.0 x 3.5 cms. This major piece is surrounded by many bony fragments. The talus has a very small bone chip which measures 1.8 x 1.2 cms. The navicular bone is fractured into two pieces of equal size. The cuboid is intact. The cuneiform bones are all intact. There are no fractures of the metatarsals. With proper medical treatment and therapy it is anticipated that an amputation would not be required.
3153	6	1-1/16x2x5"	23.1	There is no soft tissue damage. There is a deep depression on the plantar surface. Dissection reveals that there is a chip fracture of the head of the tibia where it articulates with the talus. The chip portion measures 1.0 x 2.0 x 1.0 cms. The fracture is minor. The calcaneus is fractured into 2 large pieces surrounded by bony fragments. The talus is undamaged. There is a small chip fracture of the navicular. The cuboid is undamaged. There are fractures of the 2nd, 3rd, 4th and 5th metatarsals but no fractures of the phalanges. The 4th and 5th metatarsals are rather severely comminuted into many bony fragments while the 2nd and 3rd metatarsals have only chip fractures. There are no other fractures. With proper medical treatment and therapy it is anticipated that an amputation would not be required.

Table C4

CRDL AUTOPSY REPORTS ON CONCEPT D. CADAVER LOWER EXTREMITIES

CRDL Number	IIFRI Number	Footwear Description	CRDL AUTOPSY DESCRIPTION
3154	D1	1-1/16x2-5/8x6" with heel cup	Slight depression in the plantar surface of the heel. No external lacerations. Internal examination reveals that the lower 1/2 calcaneus is severely comminuted. One major piece remaining which is upper half. Slight chip fracture plantar surface of talus near its articulation with navicular. Navicular chip fractured on its articular face with cuboid. Cuboid has a slight chip fracture on its plantar surface at its connector with the navicular. Slight chip fracture on the posterior edge of the head of the lateral malleolus. No further bone damage.
3157	D2	Same as above	No external lacerations. Slight depression in plantar surface of heel. Calcaneus moderately comminuted, one third remaining in one piece. Comminution occurs along lateral and plantar margins to its distal articulation. Slight chip fractures of lateral and medial edges of the talus at its articular edges with calcaneus. The head of the medial malleolus also slightly chip fractured. No other damage to talus. The navicular is comminuted on its medial and plantar faces. Multiple longitudinal fracture of articular face of cuboid with fifth metatarsal. Plantar fractures of the third cuneiform and the plantar aspects of the third, fourth and fifth metatarsal heads.
3159	D4	Same as above	No soft tissue injuries. The flattening deformity of foot. Comminuted fracture of calcaneus. Fracture of cuboid.
3160	D5	Same as above	Marked deformity of foot. No soft tissue injuries. Comminuted fracture of calcaneus with multiple small fragments. Transverse fracture through middle of talus.
3162	D3	Same as above	Flattening deformity of foot. No soft tissue injuries. Calcaneus comminuted but still retained in fairly large piece. No other fractures.

CRDL AUTOPSY REPORTS ON CONCEPT E CADAVER LOWER EXTREMITIES

CRDL Number	IITRI Number	Footwear Description	CRDL AUTOPSY DESCRIPTION
3155	E2	1-1/16x2-5/8x6" no heel cup	Grossly there is a marked deformity with a flattening of the foot. The plantar surface is concave. No soft tissue injuries. Calcaneus comminuted with numerous small fragments, particularly the distal half. Inferior and anterior articular surface of talus fractured. Articular surface of tibia fractured. Navicular bone fractured. Chip fracture of second cuneiform.
3156	E1	Same as above	Flattened deformity of the foot. On plantar surface 7 cm from heel there is a 2.5 cm midline laceration. Calcaneus comminuted into 6 large fragments and a number of smaller pieces. Chip fracture medial aspect of talus. Fracture of proximal articular surface and body of navicular.
3158	E4	Same as above	Marked flattening deformity of foot with gross obvious fracturing of tibia and fibula. Below lateral malleolus there is a laceration 6 cm in length and 2.5 cm in width. Below medial malleolus there is a similar laceration 7 cm in length, 2 cm in width. Plantar surface is intact. There are complete transverse fractures of distal tibia and fibula. Both talus and calcaneus are markedly comminuted with numerous small fragments and complete loss of joint spaces. Navicular and cuboid bone also fractured.
3161	E5	Same as above	There is a 4 cm vertical laceration extending up the side of the heel beginning 1.3 cm from plantar surface and 4 cm from dorsal margin of heel. This laceration measures 2 cm at its middle and a fragmented piece of bone protrudes from and occludes the opening. A 1.5 cm split in the midline of the dorsal heel extends vertically from the plantar edge. A diagonal tear in skin begins 2.3 cm from dorsal margin of heel at the plantar surface and extends for 7.2 cm to medial ankle. There is no gross depression on plantar heel. Upon dissection severe comminution of calcaneus. Multiple through and through fractures of the posterior portion of the fibula is heavily chip fractured on its lateral margin. The tibia is fractured vertically along its medial aspect from the beginning of the malleolus from its talar articulation, vertically for a distance of 4.5 cm. The navicular and cuboid are completely comminuted. The first, second and third cuneiforms are fractured extensively on their plantar aspects. The heads of the fourth and fifth metatarsals are fractured on their plantar surfaces.
3163	E3	Same as above	Soft tissue damage on the lateral aspect of the malleolus measuring 8 cm by 2 cm at its widest point. There are 2 minor chip fractures on the articular head of the tibia. The calcaneus is comminuted with one major remaining piece measuring 5 cm x 3 cm x 2.4 cm. The remaining pieces of the calcaneus are bony fragments. The talus is intact. The cuboid is intact. The navicular is intact. There are no other fractures.

TABLE 66

CRDL AUTOPSY REPORT ON CADVER LOWER EXTREMITY PROTECTED BY THE DMS PROTECTIVE
BOOT WITH CUTAWAY HEEL OUTSOLE, ONE PIECE SHANK, AND LEATHER COUNTER

CRDL TEST NUMBER	LOADING DEVICE MASS	FOOT DAMAGE	BONES FRACTURES	
3300	160 lbs	Laceration on plantar surface 11 cm X 8.5 cm; 5 cm X 3 cm. Extensive soft tissue damage to plantar surface.	Comminuted fracture of calcaneus, talus and the navicular is in two pieces of equal size. Distal end of fibula fractured.	
3301	160 lbs	Laceration on plantar surface 7.6 cm X 1.1 cm at its widest point. Laceration on lateral aspect of heel 11.3 cm X 4 cm at its widest point. Laceration on medial aspect 3.9 cm X 1.4 cm at its widest point. Laceration on posterior aspect 4.1 cm X 0.9 cm at its widest point.	Severe comminuted calcaneus into many bony fragments. Talus fractured into two major pieces of approximately equal size. Navicular fractured into two major pieces of approximately equal size. Cuboid fractured leaving two major pieces surrounded by many bony fragments.	
3302	160 lbs	Minor skin laceration on lateral aspect of heel 7.3 cm X 1.8 cm at its widest point. Minor skin laceration on plantar surface 8.9 cm X 1.2 cm at its widest point. Deep laceration on heel 7.6 cm X 1.7 cm at its widest point. Minor skin laceration on medial aspect of heel 6.3 cm X 1.2 cm at its widest point.	Severe comminuted calcaneus. Talus fractured with one large piece remaining surrounded by many bony fragments. Chip fracture of navicular. Comminuted fracture of cuboid. Severe fracture of tibia and fibula.	
3303	160 lbs.	Minor laceration on plantar surface of foot 0.8 cm X 0.1 cm. Large laceration on medial aspect of foot 5.8 cm X 2.5 cm. Small laceration on posterior aspect 3.2 cm X 0.8 cm; on lateral aspect 7.0 cm X 2.5 cm.	Severe comminuted calcaneus with many small bony fragments. Fracture of talus into two large pieces. Fracture of navicular, cuboid, first, second and third cuneiforms.	
3304	None	Large massive wound on plantar surface of foot 16 cm X 7 cm at its widest point.	Very severe comminuted fracture of calcaneus with many small bony fragments. Comminution of talus into two large pieces. Fracture of cuboid, first, second and third cuneiforms. Fracture of distal end of tibia horizontally measuring 4 cm.	
3305	None	Two large longitudinal wounds on plantar surface: one margin beginning about 1.5 cm from posterior edge of heel and running axially for 12.4 cm. This laceration is 2.7 cm at its middle. The other, medially situated, is 12.5 cm long and 2.4 cm wide at the middle. A vertical spindle shaped laceration on medial side measures 7.4 cm long ending just in front of ankle. It is 2.4 cm wide at middle. A vertical 4.5 cm laceration on posterior heel begins at plantar edge, curves for 8.5 cm to tibia and begins at plantar edge, curves for 8.5 cm to tibia. Another laceration begins 2.7 cm anterior to tibia, another laceration begins 3 cm from plantar edge, runs diagonally for 2.7 cm towards malleolus. Another on this lateral surface 3.6 cm anterior to latter begins at plantar edge and extends diagonally 9.5 cm to instep.	Complete pulverization of calcaneus. Heavy fracture of talus. Moderate chip fracturing of navicular and first, second and third cuneiforms. Fractures of heads of first and fifth metatarsals. Comminution of complete heads of tibia and fibula.	
3306	160 lbs	Large gaping wound on plantar surface of heel, 11.8 x 1.6 cm at its widest point. Laceration on lateral aspect of heel 8.2 cm X 3.5 cm at its widest point. Laceration on medial aspect of heel 7.2 cm X 2.4 cm at its widest point.	Severe comminuted fracture of calcaneus into many fragments. Comminuted fracture of navicular. Talus is fractured into two sections of approximately equal size. Fracture of cuboid. Fracture of tibia 16 cm upward from distal head. Fracture of fibula 7.5 cm upward from distal head.	
3307	160 lbs	Massive traumatic mutilation of entire heel with one major laceration extending 8 cm from the Great toe. Several other lacerations along both sides and back of heel extending as high as both malleoli.	Severe comminution of calcaneus. Extensive comminution of talus, navicular, cuboid. Heavy chip fracturing of first cuneiform on medial aspect, second and third cuneiforms on plantar facets. Also slight chip fractures on heads of second, third and fourth metatarsals. Severe comminuted damage to long bones up to 12 cm their vertical shafts.	

CRDL AUTOPSY REPORT ON CADAVER LOWER EXTREMITY PROTECTED BY THE IWS PROTECTIVE
BOOT WITH FULL HEEL OUTSOLE, ONE PIECE SHANK, AND LEATHER COUNTERS

CRDL TEST NUMBER	LOADING DEVICE MASS	FOOT DAMAGE	BONE FRACTURES
3310	160 lbs.	Large gaping wound of entire plantar area of heel measuring 16 cm X 13 cm at widest point.	Severe comminution of calcaneus. Talus comminuted with one major piece remaining surrounded by many bony fragments. Tibia and fibula fractured severely. Navicular fractured into three major pieces. Cuboid severely comminuted. First cuneiform bone fractured into three major pieces.
3311	160 lbs.	Complete mutilation of entire plantar surface of heel.	Severe comminution of calcaneus. Talus comminuted with only three major pieces remaining surrounded by many bony fragments. Cuboid fractured with one major piece remaining surrounded by many bony fragments. Head of fibula fractured. Severe fracture of tibia 24 cm proximal from talus.
3312	160 lbs.	Deep laceration on plantar surface extending over malleolus measuring 15.5 cm X 2.6 cm at its widest point. Minor laceration on medial aspect of heel measuring 6.6 cm X 1.7 cm at its widest point. Laceration on heel measuring 5.2 cm X 0.9 cm at its widest point.	Severe comminution of calcaneus into many bony fragments. Talus fractured leaving approximately 3/4 of original size surrounded by bony fragments. Navicular fractured into two pieces of approximately equal size. Chip fracture of third cuneiform. Comminuted fracture of cuboid. Tibia severely fractured.
3313	160 lbs.	Two large lacerations on lateral aspect of foot measuring 7.7 cm X 1.4 cm and 9.6 cm X 3.5 cm. Laceration on posterior aspect 5.2 cm X 0.7 cm. Laceration on medial aspect 8.5 cm X 2.6 cm.	Transverse comminuted fracture of tibia and fibula. Severe comminution of calcaneus with many small bony fragments. Distal end of tibia fractured. Small fracture of talus measuring 1 cm X 1.3 cm. Fracture of navicular into two small bones. Fracture of cuboid and second and third cuneiform bones.
3314	None	Severe laceration on lateral aspect of heel 10.5 cm X 2.5 cm at its widest point. Laceration on medial aspect 6.2 cm X 1.3 cm at its widest point.	Severe comminution of calcaneus. Talus fractured into approximately two equal pieces. Comminuted fracture of navicular.
3315	None	Large laceration on plantar surface of foot 11 cm X 2 cm. Laceration on medial aspect 8 cm X 1.9 cm.	Severe comminution of calcaneus with many small bony fragments. Chip fracture of malleolus measuring 2 cm. Fracture of talus, cuboid, first, second and third cuneiforms, navicular, distal end of tibia measuring 1 cm.
3316	160 lbs.	Two large lacerations on lateral aspect: 5 cm X 1 cm; 5.9 cm X 1.9 cm. One laceration on medial aspect 6 cm X 1.5 cm.	Severe comminution of calcaneus, cuboid, talus. Fracture of second and third cuneiforms, navicular. Fracture of distal end of articulating surface of tibia measuring 4.5 cm X 2.5 cm. Transverse comminuted fracture of distal 1/3 of tibia. Fracture of distal end of fibula.
3317	160 lbs.	Complete mutilation of entire plantar area from the metatarsals back.	Severe comminution of calcaneus. Comminuted fracture of talus, navicular, cuboid. Chip fracture of first, second and third cuneiforms. Severe comminuted fracture of tibia and fibula extending upward 23 cm from distal head.

TABLE C8

COUL AUTOPSY REPORT ON CADAVER LOWER EXTREMITY PROTECTED BY THE DMS PROTECTIVE BOOT WITH CUTAWAY HEEL OUTSOLE, TWO PIECE PANK, AND LEATHER COUNTER

CRDL. TEST NUMBER	LOADING DEVICE #4-55	FOOT DAMAGE	BONE FRACTURES	
3320	160 lbs.	Small gaping wound on plantar surface of heel 4 cm X 1.5 cm X 4 cm X 0.5 cm. Laceration on posterior surface of heel measuring 7.3 cm X 5 cm. Small laceration on medial aspect of foot 4.2 cm X 1.2 cm.	Severe comminution of calcaneus into many bony fragments. A small chip fracture of talus. Navicular severely fractured into two pieces of approximately equal size. Cuboid fractured into many small bone fragments. Distal head of tibia and fibula severely comminuted.	Severe comminution of calcaneus, talus. Fracture distally of tibia and fibula. Transverse comminuted fracture at mid-shaft of tibia.
3321	160 lbs.	Laceration of lateral aspect of heel 9.9 cm X 3.2 cm at its widest point. Laceration on medial aspect of heel 3.4 cm X 0.6 cm at its widest point.	Deep laceration on plantar surface extending 14.5 cm upward. 2.6 cm at its widest point.	Severe comminution of calcaneus. Talus fractured leaving two major pieces surrounded by bony fragments. Comminuted fracture of navicular. Comminuted fracture of cuboid.
3322	160 lbs.	Laceration on medial side of plantar edge posterior to malleolus. 7.3 cm long, 2.2 cm wide. Laceration on lateral surface 7.2 cm long, 2.2 cm wide. A 1.7 cm laceration on plantar surface beginning 2.8 cm from lateral margin and 7.8 cm from dorsal margin. A 1.9 cm laceration on medial plantar edge. One laceration on posterior heel extending upward for 3 cm.	Laceration on lateral aspect of heel 7.2 cm X 2.7 cm at widest point. Two lacerations on medial aspect: 5.8 cm X 1.2 cm; 5.3 cm X 0.4 cm. Laceration on posterior surface of heel 2.6 cm X 0.3 cm.	Extensive comminution of all tarsi. Heads of metatarsals extensive fracturing of tibia, fibula for 7 cm up from tarsal articulation.
3323	160 lbs.	A 3.7 cm laceration on lateral side beginning 2.3 cm from plantar edge extending obliquely forward ending just above the malleolus. Laceration on opposite side, similar location extending 0.8 cm from plantar edge extending obliquely forward for 7.7 cm ending above malleolus measuring 1.7 cm at the middle. Slightly curving tear on mid-line plantar surface measuring 1.8 cm long, begins 3 cm from posterior heel and extends axially.	Complete comminution of calcaneus. One major posterior piece remains. Slight chip fracture of talus on its articular face with the calcaneus. Large piece fracture chipped off medial edge of navicular. One head of third metatarsal. One-half of tibia head broken. Chip fracture on lateral surface of head of fibula.	Severe comminution of calcaneus. Minor chip fracture of talus. Comminuted fracture of navicular, cuboid, first cuneiform. Chip fracture of third cuneiform. Fracture of tibia 10.6 cm upward from distal head of tibia.
3324	None	Laceration 7.5 cm on medial aspect beginning at plantar edge in vertical line with the navicular and extending obliquely forward to a point just in front of this bone. A similar laceration on lateral side begins at plantar edge and extends obliquely for same distance to a point just above the lateral malleolus. Another laceration 4.3 cm anterior to latter begins at plantar edge and extends vertically. Defect measures 5.5 cm toward instep. This spindle-shaped defect measures 0.4 cm at its middle; 1.4 cm at its middle. On the plantar surface the first laceration just lateral to median axis at a point 0.4 cm from posterior margin of heel and 3.2 cm from lateral edge. This longitudinal laceration measures 5.5 cm long and 0.3 cm wide. Another slight tear begins 4.2 cm from posterior heel and 2 cm from medial margin and runs obliquely towards mid-line for 0.9 cm.	Laceration on medial aspect of malleolus 6.3 cm X 1.8 cm at its widest point. Gaping wound or posterior aspect of heel.	Extensive comminuted calcaneus with one major piece remaining measuring 6.5 cm X 4 cm X 3 cm. Heavy chip fracture of talus on posterior portion of its articular surface with tibia. Heavy fracturing of navicular on its plantar one-third. Also heavy chip fracturing of first, second and third cuneiforms on their plantar aspect as well as heads of second, third and fourth metatarsals. Shaft of third metatarsal transversely broken.
3325	None	Laceration on medial aspect of heel 7.2 cm X 2.7 cm at widest point. Two lacerations on medial aspect: 5.8 cm X 1.2 cm; 5.3 cm X 0.4 cm. Laceration on posterior surface of heel 2.6 cm X 0.3 cm.	Laceration on medial aspect of heel 7.2 cm X 2.7 cm at widest point. Two lacerations on medial aspect: 5.8 cm X 1.2 cm; 5.3 cm X 0.4 cm. Laceration on posterior surface of heel 2.6 cm X 0.3 cm.	Severe comminution of calcaneus. Minor chip fracture of talus. Comminuted fracture of navicular, cuboid, first cuneiform. Chip fracture of third cuneiform. Fracture of tibia 10.6 cm upward from distal head of tibia.
3326	160 lbs.	Laceration 7.5 cm on medial aspect beginning at plantar edge in vertical line with the navicular and extending obliquely forward to a point just in front of this bone. A similar laceration on lateral side begins at plantar edge and extends obliquely for same distance to a point just above the lateral malleolus. Another laceration 4.3 cm anterior to latter begins at plantar edge and extends vertically. Defect measures 5.5 cm toward instep. This spindle-shaped defect measures 0.4 cm at its middle; 1.4 cm at its middle. On the plantar surface the first laceration just lateral to median axis at a point 0.4 cm from posterior margin of heel and 3.2 cm from lateral edge. This longitudinal laceration measures 5.5 cm long and 0.3 cm wide. Another slight tear begins 4.2 cm from posterior heel and 2 cm from medial margin and runs obliquely towards mid-line for 0.9 cm.	Laceration on medial aspect of malleolus 6.3 cm X 1.8 cm at its widest point. Gaping wound or posterior aspect of heel.	Severe comminuted fracture of calcaneus, talus navicular and distal head of fibula.

TABLE C9

CRDL AUTOPSY REPORT ON CADAVER LOWER EXTREMITY PROTECTED BY THE DMS PROTECTIVE
 BOOT WITH FULL HEEL OUTSOLE, TWO PIECE SHANK, AND LEATHER COUNTER

CRDL TEST NUMBER	LOADING DEVICE MASS	FOOT DAMAGE		BONE FRACTURES
3330	160 lbs.	Large gaping wound on plantar surface of heel measuring 12 cm X 12 cm.		Severe comminution of calcaneus, talus, navicular and cuboid. Transverse comminuted fracture of tibia. Fracture of fibula distally.
3331	160 lbs.	Large gaping wound on plantar surface of heel measuring 13.7 cm X 4.7 cm. Laceration on medial aspect of foot measuring 6.9 cm X 2 cm. Laceration on posterior aspect of heel measuring 6.9 cm X 1.5 cm.		Severe comminution of calcaneus, talus, cuboid, navicular and cuneiforms. Transverse comminuted fracture of tibia distally and proximally. Transverse comminuted fracture of fibula.
3332	160 lbs.	Complete mutilation of posterior heel. Deep laceration of medial aspect of heel 12.6 cm X 2.6 cm. Minor skin laceration on lateral aspect of heel 7.5 cm X 1.3 cm at widest point.		Severe comminution of calcaneus. Comminuted fracture of navicular. Minor chip fracture of cuboid. Severe fracture of tibia and fibula at distal head. Severe fracture of tibia and fibula 21 cm proximal from talo-tibio articulation.
3333	160 lbs.	Very large laceration on plantar surface of foot measuring 10.2 cm X 6.7 cm at widest margin; on lateral aspect 6.7 cm X 4.4 cm; on medial aspect 6.3 cm X 3 cm.		Severe comminution of calcaneus into many small bony fragments. Fracture of talus, cuboid, navicular, second and third cuneiform bones, second and third metatarsals.
3334	None	Large laceration on plantar surface of foot 11.5 cm X 6 cm. Laceration on lateral aspect 7.5 cm X 3.5 cm; on posterior aspect 4 cm X 0.8 cm. 2.3 cm X 0.1 cm.		Severe comminution of calcaneus into many small bony fragments. Fracture of talus, cuboid, navicular, first, second and third cuneiforms. Fracture of distal end of tibia.
3335	None	Two major lacerations on medial side one beginning 1 cm from mid-line of posterior heel and 0.7 cm from plantar edge which extends diagonally toward front of leg for 6.2 cm. This defect measures 1.8 cm wide at the middle. The other runs diagonally toward front of foot, begins 2 cm on plantar surface, extends up medial side for 3 cm. A third smaller laceration begins on plantar surface in the mid-line, runs medially for 3 cm onto lateral aspect. Large gaping wound begins in mid-line of plantar surface 1.8 cm anterior to heel margin and extends vertically up lateral surface for 12.3 cm. Wound measures 3.5 cm at middle. Another laceration, 4.7 cm anterior to this, begins 1 cm from plantar edge, extends slightly obliquely towards front of leg for 5 cm, 1 cm wide at middle.		Calcaneus pulverized. Talus broken in two major pieces. Navicular, plantar half comminuted as well as plantar half of cuboid. Plantar surfaces of first second and third cuneiforms chip fractured. Severe fractures of metatarsals. Head of fibula moderately comminuted on lateral surface. Medial and anterior aspects of head of tibia grossly comminuted.
3336	160 lbs.	Severe soft tissue damage 15 cm X 15 cm.		Severe comminuted fracture of calcaneus. Fracture of cuboid, talus, first, second, and third cuneiforms. Fracture distally of articular surface of tibia. Transverse comminuted fracture of distal one-third of tibia and fibula.
3337	160 lbs.	Complete mutilation of entire plantar surface in the heel area.		Severe comminution of calcaneus. Comminuted fracture of talus, navicular, cuboid. Severe fracture of distal head of tibia and fibula.

TABLE C10

CRDL AUTOPSY REPORT ON CADNER LOWER EXTREMITY TESTED BY THE DMS PROTECTIVE BOOT WITH CUTAWAY HEEL OUTSOLE, ONE PIECE SHANK, AND METAL COUNTER

CRDL TEST NUMBER	LOADING DEVICE MASS	FOOT DAMAGE	BONE FRACTURES
3340	160 lbs	Laceration on lateral aspect running dorsally from plantar surface. 12.6 cm X 3.4 cm at widest point. Laceration on plantar surface 11.6 cm X 1.5 cm at widest point.	Tibia and fibula are malformed. Calcaneus severely comminuted into many bony fragments. Talus fractured into two major pieces surrounded by many bony fragments. Navicular fractured into two major pieces surrounded by many bony fragments. Small chip fracture on cuboid.
3341	160 lbs	Large gaping wound of lateral aspect of foot 13 cm X 4 cm with smaller laceration measuring 5 cm X 1.8 cm. Small laceration on plantar surface of foot measuring 1.6 cm X 0.5 cm.	Severe comminution of calcaneus. Transverse comminuted fracture of tibia and fibula.
3342	160 lbs	No damage to soft tissue that is discernable.	Fracture of cuboid, distally of tibia that connects with the talus. Talus fractures, first, second and third cuneiforms. Navicular fractured. Fracture of fifth metatarsus.
3343	160 lbs.	Severe compression deformity. Two minor skin lacerations on lateral aspect of heel: 5.4 cm X 1.8 cm; 4.5 cm X 1.8 cm. Laceration on plantar surface 5.2 cm X 0.7 cm. Laceration on medial aspect 6.4 cm X 1.4 cm.	Severe comminution of calcaneus. Minor chip fracture of talus. Navicular fractured into two approximately equal pieces. Chip fracture of cuboid. Severe fractures of tibia and fibula at distal head.
3344	None	No soft tissue damage.	Severe comminution of calcaneus. Fracture of cuboid. Talus, navicular first, second and third cuneiforms. Fourth metatarsal fractured.
3345	None	No soft tissue damage.	Comminuted fracture of calcaneus with many bony fragments. Fracture of navicular. Proximal chip fracture of second cuneiform. Linear fracture of head of talus.
3346	160 lbs.	Severe damage to soft tissue on plantar surface of foot 13.9 cm X 7 cm. Two lacerations on lateral aspect: 7 cm X 2.6 cm; 3.9 cm X 1 cm. Laceration on medial side 7 cm X 3.4 cm.	Severe comminution of calcaneus with many small bony fragments. Severe comminution of cuboid, talus, navicular, first, second and third cuneiforms. Chip fracture of first and fifth metatarsals. Fracture of distal end of articular surface of tibia.
3347	160 lbs.	"v" shaped defect on lateral posterior heel. Laceration measures 5.7 cm. Laceration begins at plantar edge on posterior heel just lateral to mid-line.	Calcaneus extremely comminuted. Moderate sized chip from plantar surface of navicular.

TABLE C11

CRDL AUTOPSY REPORT ON CADAVER LOWER EXTREMITY PROTECTED BY THE DMS PROTECTIVE
BOOT WITH FULL HEEL OUTSOLE, ONE PIECE SHANK, AND METAL COUNTER

CRDL TEST NUMBER	LOADING DEVICE MASS	FOOT DAMAGE	BONE FRACTURES
3350	160 lbs.	Small laceration on lateral aspect of foot 5.5 cm X 2 cm.	Comminuted fracture of calcaneus and talus, navicular, cuboid, third cuneiform.
3351	160 lbs.	Extensive and massive external trauma. Almost complete traumatic amputation at mid-arch. Gross lacerations over all surfaces of foot.	Gross comminution of calcaneus and talus. Extensive fractures of plantar surfaces of navicular and cuneiforms. Distal shaft and head fractures of second through fifth metatarsals. Heads of both malleoli slight chip fractured. Anterior aspect of head of tibia slightly chip fractured.
3353	160 lbs.	Laceration on medial aspect 6.5 cm X 2 cm. Another laceration on lateral aspect 8 cm X 2.3 cm.	Severe comminution of calcaneus. Fracture of cuboid, navicular, fourth and fifth metatarsals.
3354	None	No soft tissue damage.	Severe comminution of calcaneus, cuboid, navicular, third cuneiform. Chip fracture of plantar surface of second cuneiform. Heavy fracture of plantar surfaces of first, second and third metatarsals heads. Shafts of fourth and fifth metatarsals broken. Talus broken into three major pieces; one through and through from plantar to dorsal articulation. Heads of medial and lateral malleolus is slightly chip fractured.
3355	None	Soft tissue damage on medial and posterior aspect of heel: medial aspect 4 cm X 1.2 cm; posterior aspect 4 cm X 1 cm.	Severe comminution of calcaneus. Fracture of distal end of tibia. Fracture of cuboid, third cuneiform, small chip off the navicular.
3356	160 lbs.	No soft tissue damage.	Severe compression deformation of plantar area. Severe comminuted fracture of calcaneus. Talus fractured into two major pieces of equal size. Comminuted fracture of cuboid and navicular. Chip fracture of first, second and third cuneiforms. Small chip fracture of head of fibula.
3357	160 lbs.	Soft tissue damage on plantar surface of foot: 6.9 cm X 7.8 cm. Laceration on lateral side of foot: 7.4 cm X 2.3 cm. Laceration on medial aspect: 7.2 cm X 2.2 cm.	Severe comminuted fracture of calcaneus. Fracture of talus, navicular, cuboid, first, second and third cuneiforms, first metatarsal. Fracture of distal end of tibia with one large chip.

TABLE C12

CEDL AUTOPSY REPORT ON CADAVER LOWER EXTREMITY PROTECTED BY THE DMS PROTECTIVE BOOT WITH CUTAWAY HEEL OUTSOLE, TWO PIECE SHANK, AND METAL COURIER

CRDL TEST NUMBER	LOADING DEVICE MASS	FOOT DAMAGE	BONE FRACTURES
3360	160 lbs.	Laceration on plantar surface of heel: 5.1 cm X 1.3 cm.	Comminuted fracture of calcaneus, talus, navicular. Transverse comminuted fracture of tibia at mid-shaft.
3361	160 lbs.	Large gaping wound on plantar surface of foot: 14 cm X 8 cm. Three small lacerations on medial aspect of foot: 6 cm X 2 cm; 3.2 cm X 1.5 cm; 4.5 cm X 1.7 cm. Large gaping wound on lateral aspect: 6 cm X 4.5 cm.	Comminuted fracture of calcaneus, talus, cuboid. Third cuneiform, navicular. Comminuted fracture of fibula. Comminuted fracture of distal end of tibia.
3362	160 lbs.	Laceration on medial aspect: 5.3 cm X 0.8 cm at widest point. Laceration on lateral aspect of heel: 5.7 cm X 1.9 cm at widest point.	Severe comminution of calcaneus with one major piece remaining. Navicular fractured into two pieces of approximately equal size.
3363	160 lbs.	Laceration on lateral aspect of heel: 5.6 cm X 1.9 cm at widest point.	Severe comminution of calcaneus. Fracture of navicular. Talus fractured into approximately two equal pieces.
3364	None	Small laceration on plantar surface of foot: 3 cm X 1.5 cm.	Severe comminution of calcaneus. Fracture of cuboid. distal end of tibia, talus, navicular, first, second and third cuneiforms, malleolus.
3365	None	No soft tissue damage	Comminuted fracture of tibia and fibula. Severe comminution of calcaneus. Fracture of distal end of tibia. Fracture of talus, navicular, first, second and third cuneiforms.
3366	160 lbs.	Soft tissue damage on plantar surface of foot: 15 cm X 11 cm. Laceration on lateral side: 9 cm X 4.5 cm.	Severe comminution of calcaneus, talus, cuboid. First cuneiform fractured in half. Fracture of head of first metatarsal. Fracture of second and third cuneiforms, navicular. Small chip on distal end of tibia: 3 cm X 0.1 cm.
3367	160 lbs.	Foot is desiccated and hardened on lower surfaces. Laceration on medial surface beginning 1 cm above plantar edge and extending obliquely for 4 cm, ending just below and in front of malleolus. 1 cm at widest point. Laceration on lateral surface beginning on plantar edge: 2 cm at middle.	Extreme comminution of calcaneus.

TABLE C13

CRDL AUTOPSY REPORT ON CAUDAVER LOWER EXTREMITY PROTECTED BY THE DMS PROTECTIVE BOOT WITH FULL HEEL OUTSOLE, TWO PIECE SHANK, AND METAL COUNTER

CRDL TEST NUMBER	LOADING DEVICE MASS	FOOT DAMAGE	BONE FRACTURE
3370	160 lbs.	Severe laceration on plantar surface of foot: 11 cm X 1.5 cm with four small lacerations on lateral aspect: 4.5 cm X 0.9 cm; 7 cm X 2.2 cm; posterior: 6.3 cm X 1.1 cm; 3 cm X 0.3 cm.	Severe comminution of calcaneus and navicular.
3371	160 lbs.	Laceration on medial aspect of plantar surface: 6.5 cm X 1.3 cm.	Calcaneus grossly comminuted. Talus contains hairline fracture. Multiple fractures of head of talus. Navicular comminuted. Heads of first and second metatarsals fractured.
3372	160 lbs.	Two lacerations in heel area: 1.5 cm and 1.9 cm. Laceration on lateral surface of plantar edge: 6.2 cm long X 1.7 cm at widest point. Irregular shaped wound on plantar surface: 1.2 cm X 4.6 cm X 4.3 cm, 2.3 cm at widest point.	Massive comminution and fracturing of all tarai and metatarsals. Heads of both malleoli fractured.
3373	160 lbs.	Laceration on medial aspect of foot: 4 cm X 0.5 cm. Another around ankle region: 2.6 cm X 0.6 cm. Small laceration on lateral aspect of foot: 2.2 cm X 0.5 cm.	Severe comminution of calcaneus. Fracture of cuboid, navicular, talus, fourth metatarsal, tibia and fibula.
3374	None	Laceration on plantar surface: 7.6 cm X 1.9 cm at widest point.	Severe comminuted fracture of calcaneus. Chip fractures of talus. Fracture of navicular. Comminuted fracture of cuboid, first and second cuneiforms. Severe comminuted fracture of distal head of tibia and fibula for 8 cm upward.
3375	None	No soft tissue damage.	Severe comminution of calcaneus. Talus fractured into two parts. Small chip off distal end of tibia. Fracture of cuboid, navicular, first, second and third cuneiforms.
3376	160 lbs.	Deep gaping wound from mid plantar are to beyond lateral malleolus measuring 17.4 cm X 3.6 cm at widest point. Laceration on medial malleolus: 8.3 cm X 1.4 cm at widest point.	Comminuted fracture of calcaneus. Minor chip fracture of talus. Fracture of navicular, cuboid, first cuneiform. Severe comminuted fracture of distal heads of tibia and fibula extending upward for 10.2 cm.
3377	160 lbs.	No soft tissue damage.	Comminuted fracture of calcaneus. Two chip fractures of talus: 1.7 cm X 0.5 cm; 2.5 cm X 1.3 cm. Fracture of navicular, first, second and third cuneiforms. Chip fracture of head of fourth metatarsal. Fracture of cuboid. Transverse comminuted fracture of distal one-third of tibia and fibula.

1 - 1
1 - 1
1 - 1
1 - 1
1 - 1
1 - 1
1 - 1
1 - 1
1 - 1

- 1 - Department of the Navy
Special Projects Office
Washington, D. C. 20360
- 1 - Arctic AEROMED Laboratory
ATTN: Librarian
APO 731, Seattle, Washington
- 1 - US Army Materiel Command
Research Division AMCRD-RL
R&D Directorate
Bldg T-7
Washington, D. C. 20315
- 1 - US Army Engineering Research
Development Laboratories
ATTN: STINFO Branch
Fort Belvoir, Virginia 22060
- 1 - Reference Center Library
The Institute for Cooperative
Research
Eglin Facility
PO Box 1867
Eglin Air Force Base, Florida
- 1 - Mr. Gerald Chaikin
US Army Missile Command
ATTN: AMSMI-PC
Redstone Arsenal, Alabama 35808
- 1 - National Research Council
University of Rhode Island
Kingston, Rhode Island 02881
- 1 - Senior Standardization Rep.
US Army Standardization Group
Canada
ATTN: US Army Stdzn Rep(QMAE)
c/o Directorate of Interservice
Development
138 Queen Street
Ottawa, Ontario, Canada

- 1 - NASA Scientific and Technical
Information Facility
ATTN: Acquisitions Branch
(S-AK/DL)
PO Box 33
College Park, Maryland 20740
- 1 - USA NLABS Liaison Office
ASDL-8
Wright-Patterson AFB, Ohio

INTERNAL DISTRIBUTION

- 20- Chief, Technical Plans Office
NLABS
(for transmittal to Defense
Documentation Center)
- 2 - Technical Library, NLABS
- 5 - Military Liaison Representative
Technical Plans Ofc, NLABS

DOCUMENT CONTROL DATA - R&D

(Security classification of title, body of abstract and indexing annotation must be entered when the overall report is classified)

1. ORIGINATING ACTIVITY (Corporate author) IIT Research Institute 10 West 35th Street Chicago, Illinois 60616		2a. REPORT SECURITY CLASSIFICATION Unclassified	
		2b. GROUP	
3. REPORT TITLE Research and Development of Blast Protective Footwear, Fabrication and Prooftesting			
4. DESCRIPTIVE NOTES (Type of report and inclusive dates) Final Report, Phase II			
5. AUTHOR(S) (Last name, first name, initial) Fujinaka, Edwin S. MacDonald, John L.			
5. REPORT DATE July 1966	7a. TOTAL NO. OF PAGES 107	7b. NO. OF REFS 8	
9a. CONTRACT OR GRANT NO. DA19-129- CM -2061 (OI-6137)	9a. ORIGINATOR'S REPORT NUMBER(S)		
b. PROJECT NO. 7-70-10-002	9b. OTHER REPORT NO(S) (Any other numbers that may be assigned this report)		
c.	67-5-CM	TS-141	
d.			
10. AVAILABILITY/LIMITATION NOTICES Distribution of this report is unlimited. Release to CFSTI is authorized.			
11. SUPPLEMENTARY NOTES		12. SPONSORING MILITARY ACTIVITY U.S. Army Natick Laboratories Natick, Mass. 01760	

13. ABSTRACT
Several of the blast protective combat boot concepts which were developed under Phase I of this program were fabricated and prooftested under Phase II. All of the protective boots incorporated a honeycomb filled shank. The high strength aluminum honeycomb filler ranged from 2550 psi to about 4200 psi nominal crushing strength.

In addition to the protective shank, several models of protective boots were fabricated with wedge-shaped heel cut outs and/or metal heel counters. A total of 150 pairs of protective boots were fabricated with eight possible combinations of the variables studied.

Sixty-four cadaver specimens protected by various types of boots were blast-loaded with the M-14 land mine. 27% of the protective boots with conventional counters resulted in a foot damage level which could possibly be "salvaged from amputation" while 63% of the protective boots incorporating a metal heel counter were "possible salvages." This compares to a zero percent rate of possible salvage with conventional footwear.

14. KEY WORDS	LINK A		LINK B		LINK C	
	ROLE	WT	ROLE	WT	ROLE	WT
Testing	8					
Boots	9		8,10		7	
Combat Footwear	9		8,10		7	
Protective	0					
Armed Forces equipment	4					
Protection	4		8			
Foot	4		9		7	
Military personnel	4		9		7	
Aluminum			8,10		7	
Shank			8,10		7	
Honeycomb			8,10		7	
Sandwich construction			8,10		7	
Metal plates			8,10		7	
Elast					6	
M-14 APERS land mine					6	

INSTRUCTIONS

1. **ORIGINATING ACTIVITY:** Enter the name and address of the contractor, subcontractor, grantee, Department of Defense activity or other organization (*corporate author*) issuing the report.
- 2a. **REPORT SECURITY CLASSIFICATION:** Enter the overall security classification of the report. Indicate whether "Restricted Data" is included. Marking is to be in accordance with appropriate security regulations.
- 2b. **GROUP:** Automatic downgrading is specified in DoD Directive 5200.10 and Armed Forces Industrial Manual. Enter the group number. Also, when applicable, show that optional markings have been used for Group 3 and Group 4 as authorized.
3. **REPORT TITLE:** Enter the complete report title in all capital letters. Titles in all cases should be unclassified. If a meaningful title cannot be selected without classification, show title classification in all capitals in parenthesis immediately following the title.
4. **DESCRIPTIVE NOTES:** If appropriate, enter the type of report, e.g., interim, progress, summary, annual, or final. Give the inclusive dates when a specific reporting period is covered.
5. **AUTHOR(S):** Enter the name(s) of author(s) as shown on or in the report. Enter last name, first name, middle initial. If military, show rank and branch of service. The name of the principal author is an absolute minimum requirement.
6. **REPORT DATE:** Enter the date of the report as day, month, year; or month, year. If more than one date appears on the report, use date of publication.
- 7a. **TOTAL NUMBER OF PAGES:** The total page count should follow normal pagination procedures, i.e., enter the number of pages containing information.
- 7b. **NUMBER OF REFERENCES:** Enter the total number of references cited in the report.
- 8a. **CONTRACT OR GRANT NUMBER:** If appropriate, enter the applicable number of the contract or grant under which the report was written.
- 8b, 8c, & 8d. **PROJECT NUMBER:** Enter the appropriate military department identification, such as project number, subproject number, system numbers, task numbers, etc.
- 9a. **ORIGINATOR'S REPORT NUMBER(S):** Enter the official report number by which the document will be identified and controlled by the originating activity. This number must be unique to this report.
- 9b. **OTHER REPORT NUMBER(S):** If the report has been assigned any other report numbers (*either by the originator or by the sponsor*), also enter this number(s).
10. **AVAILABILITY/LIMITATION NOTICES:** Enter any limitations on further dissemination of the report, other than those imposed by security classification, using standard statements such as:
- (1) "Qualified requesters may obtain copies of this report from DDC."
 - (2) "Foreign announcement and dissemination of this report by DDC is not authorized."
 - (3) "U. S. Government agencies may obtain copies of this report directly from DDC. Other qualified DDC users shall request through _____."
 - (4) "U. S. military agencies may obtain copies of this report directly from DDC. Other qualified users shall request through _____."
 - (5) "All distribution of this report is controlled. Qualified DDC users shall request through _____."
- If the report has been furnished to the Office of Technical Services, Department of Commerce, for sale to the public, indicate this fact and enter the price, if known.
11. **SUPPLEMENTARY NOTES:** Use for additional explanatory notes.
12. **SPONSORING MILITARY ACTIVITY:** Enter the name of the departmental project office or laboratory sponsoring (*paying for*) the research and development. Include address.
13. **ABSTRACT:** Enter an abstract giving a brief and factual summary of the document indicative of the report, even though it may also appear elsewhere in the body of the technical report. If additional space is required, a continuation sheet shall be attached.
- It is highly desirable that the abstract of classified reports be unclassified. Each paragraph of the abstract shall end with an indication of the military security classification of the information in the paragraph, represented as (TS), (S), (C), or (U).
- There is no limitation on the length of the abstract. However, the suggested length is from 150 to 225 words.
14. **KEY WORDS:** Key words are technically meaningful terms or short phrases that characterize a report and may be used as index entries for cataloging the report. Key words must be selected so that no security classification is required. Identifiers, such as equipment model designation, trade name, military project code name, geographic location, may be used as key words but will be followed by an indication of technical context. The assignment of links, rules, and weights is optional.