

AD 648334

*File Copy*

**21 FEB. 1952**

Distribution of this document  
is unlimited.

**INTERIM REPORT  
ON THE  
INSTALLATION OF**

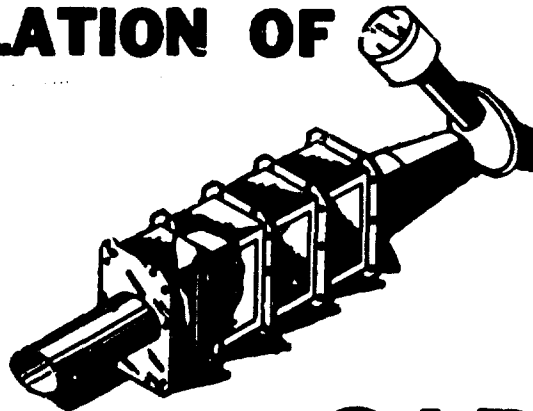

D D C  
MAR 16 1952  
D

**CARBON  
MONOXIDE  
ELIMINATOR  
MUFFLERS**

**PROJECT GROUP NO. NT-003 020 B  
ENGR. REPORT NO. 5.2120**

**U.S. Naval Supply Research & Development Facility  
Bayonne, New Jersey**

**ARCHIVE COPY**

RESEARCH AND DEVELOPMENT DIVISION  
BUREAU OF SUPPLIES AND ACCOUNTS  
WASHINGTON, D.C.

TECHNICAL REPORT REVIEW

"INTERIM REPORT ON THE INSTALLATION OF CARBON  
MONOXIDE ELIMINATOR MUFFLERS"

Project No. NT003020(b)  
Engr. Report No. 5.2120  
21 Feb. 1952

APPROVAL:

Report approved 22 May 1952; distribution of this document  
is unlimited.

SECURITY  
CLASSIFICATION:

UNCLASSIFIED

DISTRIBUTION:

In accordance with the attached approved  
distribution list.

REMARKS:

This technical report review is inserted as  
the first page of the subject report as an  
integral part thereof.

No data, discussions or recommendations in-  
cluded in this research and development report  
or technical report review shall be construed  
as indicating a current or anticipated future  
operating policy of the Bureau of Supplies and  
Accounts or the Navy Department.

/s/ J. H. TAYLOR, JR.  
Commander, (SC), USN  
Director, Research and Development Division  
By direction of the Chief of Bureau

APPROVED DISTRIBUTION LIST

"INTERIM REPORT ON THE INSTALLATION OF CARBON  
MONOXIDE ELIMINATOR MUFFLERS"

Project No. W1003020(b)

Engr. Report No. 5.2120

21 Feb. 1952

Chief, Bureau of Supplies and Accounts (Code S8) (10 copies)  
Department of the Navy  
Washington 25, D.C.

Chief, Bureau of Supplies and Accounts (Code W) (5 copies)  
Department of the Navy  
Washington 25, D.C.

Chief, Bureau of Ships (Code 522) (1 copy)  
Department of the Navy  
Washington 25, D.C.

Chief, Bureau of Ordnance (Code RELF) (1 copy)  
Department of the Navy  
Washington 25, D.C.

Chief, Bureau of Yards and Docks (Code 300) (1 copy)  
Department of the Navy  
Washington 25, D.C.

Oxy-Catalyst Manufacturing Company, Inc. (1 copy)  
115 Conestoga Road  
Wayne, Pennsylvania

Munitions Board Standards Agency (2 copies)  
Department of Defense  
Washington 25, D.C.

Commanding Officer  
Naval Supply Center  
Norfolk 11, Virginia

(1 copy)

Engineering Report No. 5.2120  
Project Group - NT003-020(b)

21 February 1952

INTERIM REPORT ON THE INSTALLATION

OF

CARBON MONOXIDE ELIMINATOR MUFFLERS

SUPPLY ENGINEERING DIVISION  
U. S. NAVAL SUPPLY RESEARCH AND DEVELOPMENT FACILITY  
U. S. NAVAL SUPPLY DEPOT  
BAYONNE, NEW JERSEY

ENGINEERING REPORT NO. 5.2120  
Project Group No. NT-003-020(b)

CARBON MONOXIDE ELIMINATOR MUFFLER

AUTHORIZATION:

ChBuSanda ltr OW-3, All/3 dtd 23 July 1951,  
Research and Development Authorization  
SE52-4; Development of a Catalytic Muffler  
to Eliminate Carbon Monoxide.

PURPOSE:

This report covers information on the in-  
stallation of catalyst mufflers from  
September, 1951 to the present. It is in-  
tended to provide a picture of the problems  
that have been encountered in conjunction  
with the use of these mufflers.

CONCLUSION:

The mufflers used in the operational tests at  
Norfolk and Bayonne have been unsatisfactory  
from an operational standpoint. They have not  
shown themselves as an attachment which could  
be placed on a fork truck and forgotten. Con-  
stant and close supervision has been necessary  
in order to get the required performance from  
these mufflers. Mechanical failures of the  
mufflers, and failures of the engine, directly  
attributable to the mechanical attachment of

the muffler, have been encountered. Certain design changes have been made and others will be required before this muffler will be a reliable and sound answer to the elimination of carbon monoxide.

RECOMMENDATIONS:

Because the carbon monoxide fume problem is present and this muffler does offer promise, it is recommended that development and design research be continued.

PROJECT NO. NT-003-020(b)

CARBON MONOXIDE ELIMINATOR

INTRODUCTION

This report covers the installation and operation of catalyst muffler equipped fork trucks since preliminary tests <sup>1/ 2/</sup> indicated the feasibility of carbon monoxide elimination by this method. The report will take into consideration the basic factors mentioned in the previous report <sup>3/</sup> namely:

1. Ease of adjustment of carburetion for proper functioning of carbon monoxide elimination.
2. Reliability for continuous operation.
3. Durability of catalytic elements under operating conditions.
4. Construction features of muffler and physical adaptability for replacement and maintenance of catalytic elements.
5. Provision of an alarm system to denote unsafe operating conditions.

Results of the previous tests indicated that development of the Oxy-Catalyst Manufacturing Company's equipment might prove worthwhile.

Eighteen mufflers were purchased subsequently from that firm. Of

---

1/ H. T. Smith, Report of Test of CO Eliminators in Fork Trucks, Report NS-623-189, U. S. Naval Engr. Exp. Station, Annapolis, Maryland, n.d.

2/ CO Eliminator Muffler, Confidential Interim Report, U. S. Naval Supply Research and Development Facility, Bayonne, N. J., 1950.

3/ Ibid, p. 12.



these eighteen mufflers, five were to be installed on 4,000 lb. capacity fork trucks already operating at the Naval Supply Center, Norfolk, Virginia. Three other mufflers were purchased afterwards for installation at Norfolk, on 6,000 lb. capacity fork trucks. The remaining ten mufflers were to be installed on new machines of 4,000 lb. capacity at Bayonne.

#### REPORT OF ORIGINAL INSTALLATION

The life-service tests on the truck which had been used in the original tests in Bayonne were interrupted by personnel changes in the Supply Engineering Division. When tests were reinstated, it was found that this muffler was inoperative and no information was available as to when the unit had failed. It was, therefore, deemed advisable to replace the catalyst sections in this muffler. New catalyst sections were received in December 1951.

This original muffler had been broken in a number of places. The manifold flange connections had cracked and the venturi coupling had broken a number of times. These mechanical failures were due jointly to the method of supporting the muffler and the connections to the engine. Figures 1 - 4 show the various parts of this muffler and the manner in which it was fastened to the Tomotor Model LT-44 fork truck. Figure 1 shows that the entire weight of the muffler is supported by means of the manifold flange connection. Figure 2 shows how this overhanging load has caused the flanged connection to crack and also shows the weld repairs. Figure 3 shows the failure at the flanged end of

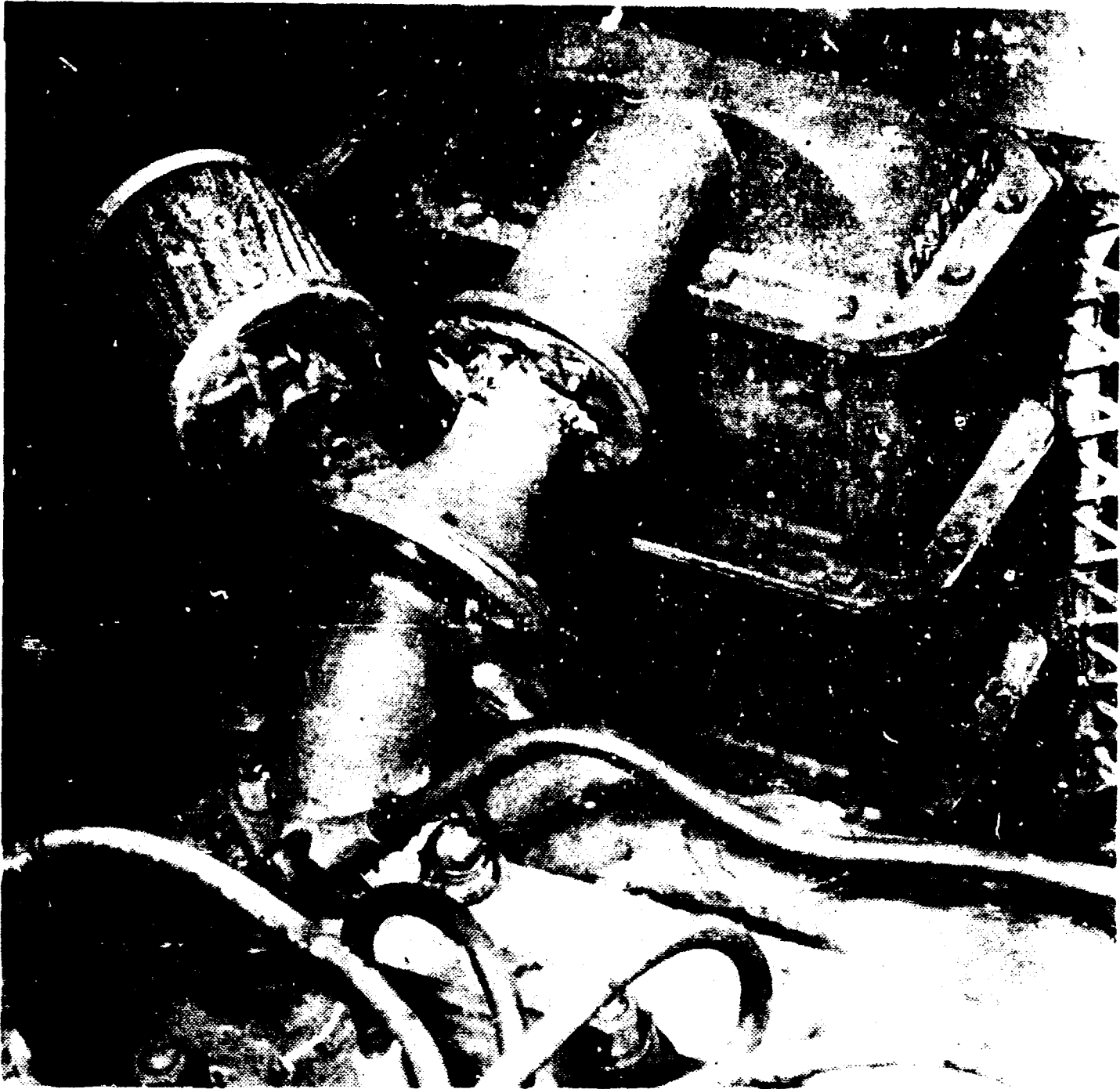

**FIG. 1 METHOD OF CONNECTING AND SUPPORTING MUFFLER SHOWING HOW ENTIRE WEIGHT IS PLACED ON MANIFOLD FLANGE AND VENTURI SECTION (USNSRDF NEG. NO. RDF-596-1)**

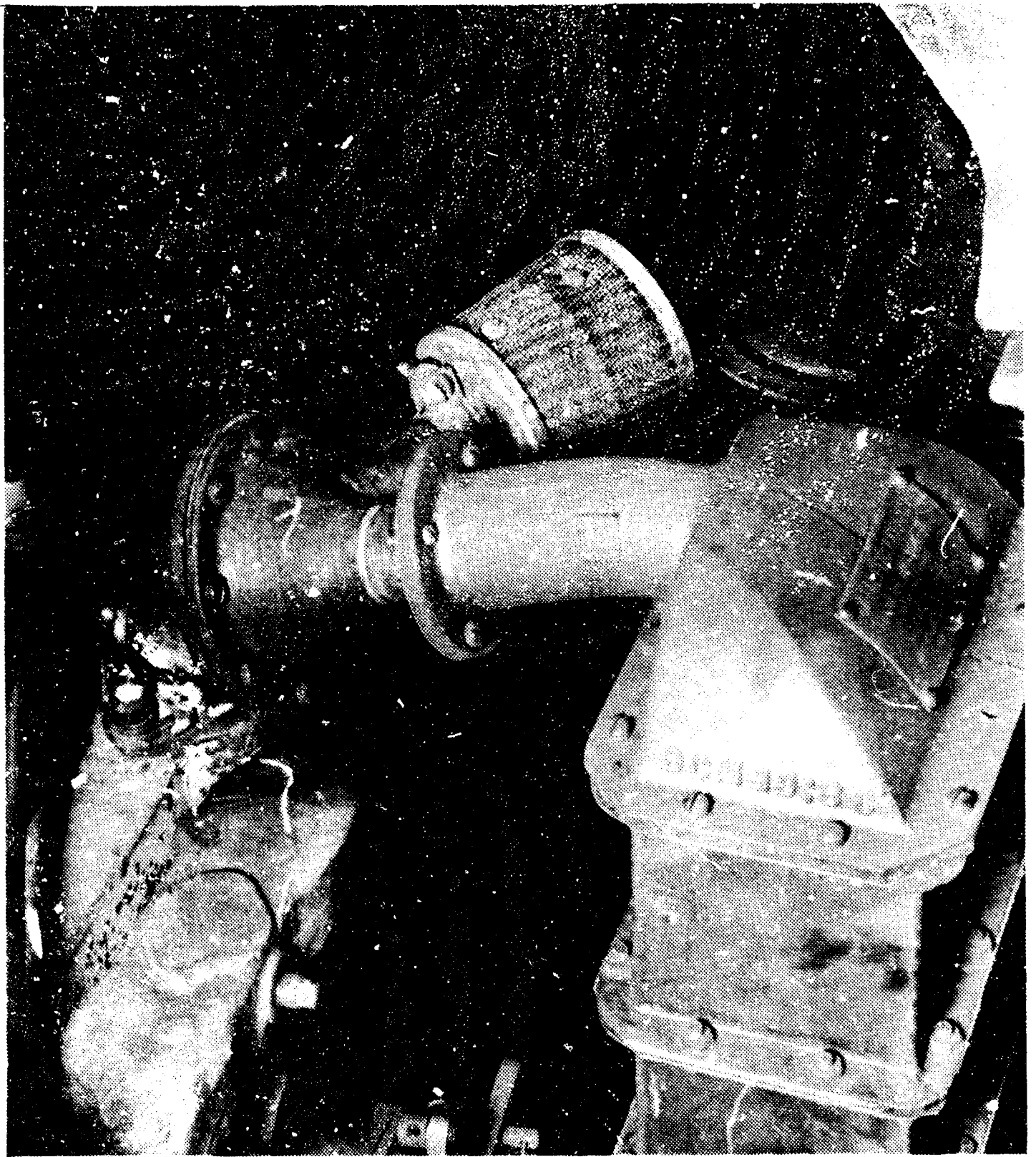

**FIG. 2 ILLUSTRATION OF REPAIRS NECESSITATED BY CRACKING OF FLANGE DUE TO WEIGHT OF MUFFLER. (USNSRDF NEG. NO. RDF-596-2)**



**FIG. 3 CLOSE-UP SHOWING FAILURES OF MANIFOLD FLANGE AND VENTURI COUPLING. (USNSRDF NEG. NO. RDF-596-3)**

the venturi and the manifold coupling. Figure 4 shows a second failure of the venturi flange after repairs had been made. Note the very light gauge material that has been used in the venturi as compared to the heavy cast flange to which this piece connects.

These failures led to a search for a new method of fastening the muffler to the engine and for supporting the muffler more adequately. A method of connecting the manifold to the muffler by means of a flexible coupling was attempted. See Figure 5. In this method the muffler was fastened rigidly to the frame and the flexible tubing was designed to take out the vibration between the engine and the frame. This method of coupling is presently under test.

#### REPORT OF NORFOLK INSTALLATION

The five mufflers for use on the 4,000 lb., Model LT-44, Towmotor machines at Norfolk were installed the week of September 7th with the assistance of a company representative. The five machines had been previously prepared in accordance with Instruction Manual SEDR 009<sup>4/</sup>. These mufflers used a different method of support than that previously employed by the Oxy-Catalyst Company. The muffler is supported by means of two arms fastened to the engine head studs, as shown in Figure 6. The muffler is supported in a cantilever fashion and vibrates with the engine. This method of fastening has its drawbacks

<sup>4/</sup> Instruction Manual - Oxy-Catalyst Muffler, SEDR-009, USNSRDF, Bayonne, N.J., n. d.

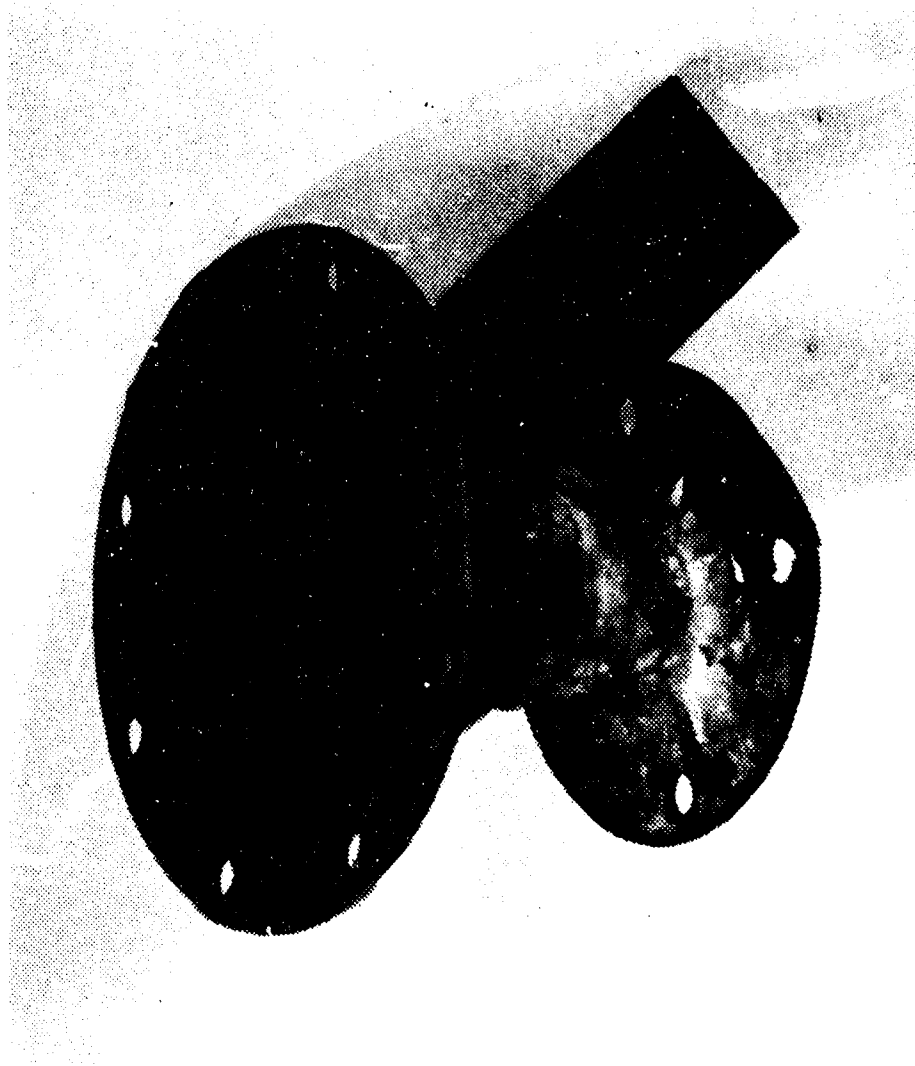

**FIG. 4 CLOSE-UP OF SECOND FAILURE OF VENTURI  
FLANGE ASCRIBED TO THE USE OF LIGHT GAUGE METAL  
AT THIS POINT. (USNSRDF NEG. NO. RDF-596-4)**

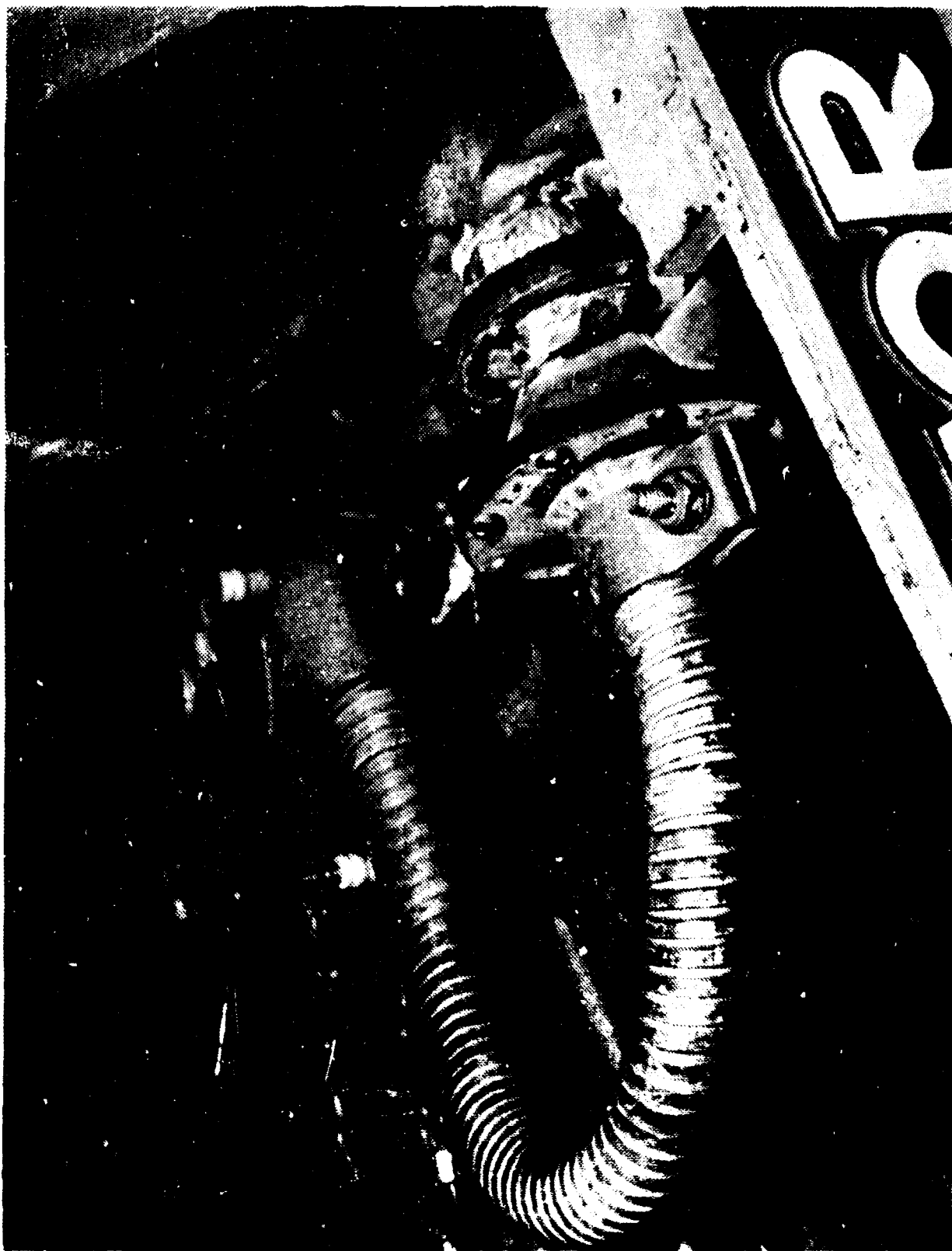

**FIG. 5 CLOSE-UP OF MANIFOLD CONNECTION SHOWING USE OF FLEXIBLE HOSE  
IN AN ATTEMPT TO ELIMINATE BREAKAGE OF THE VENTURI.  
(USNSRDF NEG. NO. RDF-26-2)**

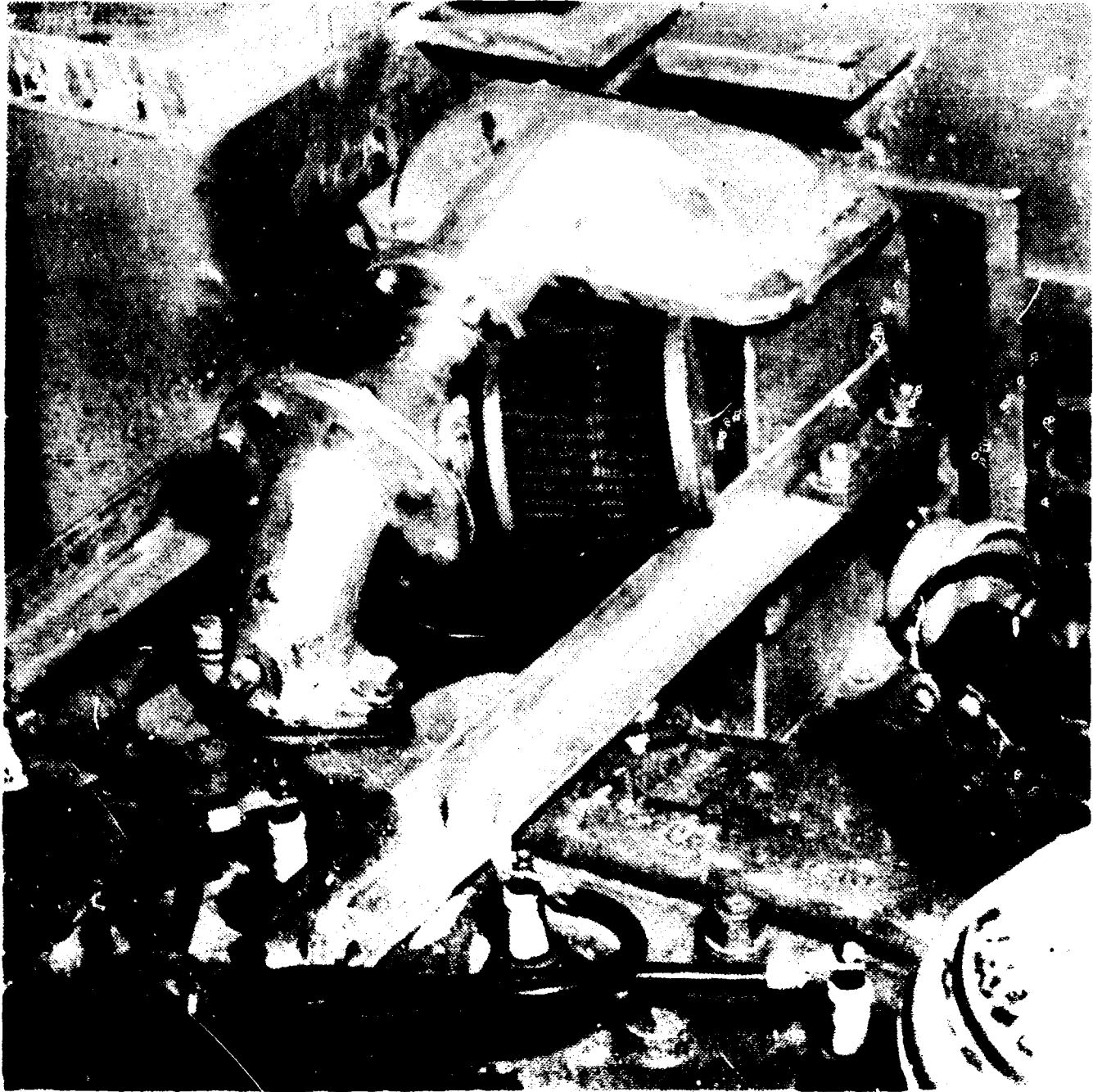

**FIG. 6 METHOD OF INSTALLING MUFFLERS ON TOWMOTOR TRUCKS AT NORFOLK SHOWING SUPPORT BRACKETS FASTENED TO ENGINE HEAD STUDS (USNSRDF NEG. NO. RDF-26-1)**



as will be emphasized later on.

#### ALARM SYSTEM

At the time of installation at Norfolk an ignition cut-out system was placed on each machine. See Figure 7. This system provided a means of turning off the engine automatically if the catalyst failed to come up to temperature. The ignition cut-out system showed signs of failure at the time of installation, and two units were inoperative before the company representative left. The three other units failed shortly thereafter and the machines were operated without the alarm system. It is believed that the units failed because the delicate clock and relay mechanisms were unable to withstand the shock and vibration imposed on them.

All the machines at Norfolk were equipped with Hobbs engine hour meters. These meters were installed so that only the actual operation of the engine started the clock mechanism recording. Norfolk was instructed to report engine hour readings along with monthly equipment service records.

The Safety Department was instructed to send any data concerning physiological effects or hazardous operation in connection with the use of these machines.

#### HEAT RADIATION PROBLEMS

Within three weeks of the installation, the machines at Norfolk were causing difficulties, and tests were delayed because of a fire

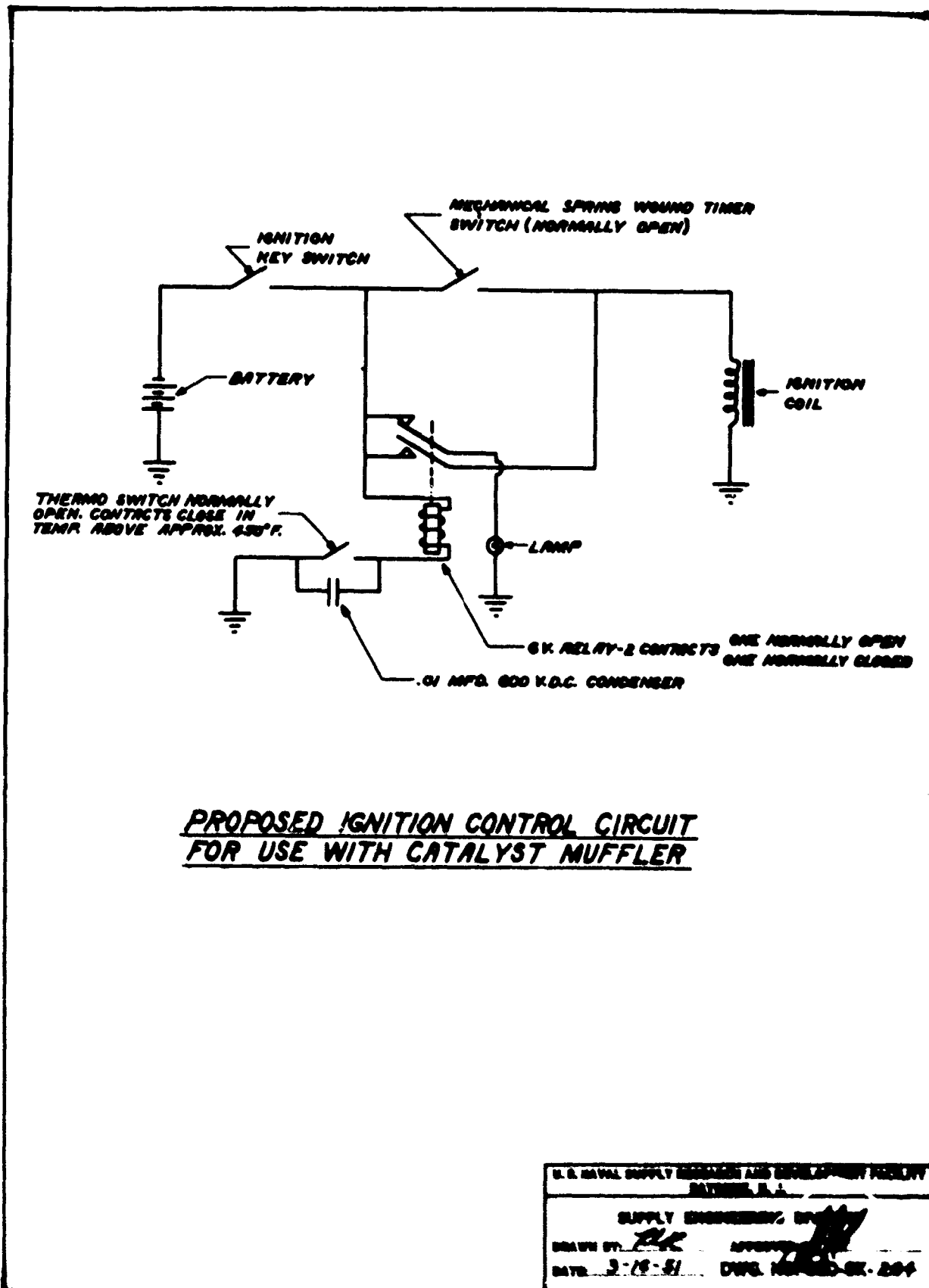

**FIG. 7 - ALARM DEVICE USED ON FIRST INSTALLATIONS . LATER REPLACED.**

hazard. The mufflers were radiating sufficient heat to cause blistering of the paint on the side walls of the fork truck. See Figure 8. The Safety Department at NSC, Norfolk, sent the following report:

"From the enclosed photograph you will note scorched area due to heat from the muffler being transferred to the frame of the counterweight. This also presents a considerable hazard from gasoline vapors when refueling. In order to refuel safely, it is necessary that the equipment set until the muffler has cooled off and this naturally, slows up operations."<sup>5/</sup>

This activity recommended that a "sandwich" of asbestos and metal be placed between the face of the muffler and the side walls of the truck. This measure alleviated the condition. Such a heat shield installation is shown in Figure 9.

Heat radiation from this muffler is an acute problem. If the air-fuel ratio of the carburetor is too low (rich), the temperature of the catalyst will become quite high. This is substantiated by the fact that side-wall temperatures in excess of 600°F have been recorded; and in several instances, the side-walls have been seen to be glowing dull red. The usual side-wall temperatures appear to range from 350° to 600°F. To cut down on heat radiation, it was found that painting of the muffler surfaces with aluminum paint reduced the temperatures of adjacent parts of the fork truck 30° to 40°F.

---

<sup>5/</sup> NSC, NORVA ltr 11E:PS, dtd 25 Sept 1951 to OinC, USNSRDP, Bayonne, N. J.



**FIG. 8** BLISTERING AND SCORCHING OF  
**PAINT ON TRUCK FRAME CAUSED BY HEAT**  
**RADIATION FROM MUFFLER.**  
**(USN SC NORVA NEG. NO. 13834)**

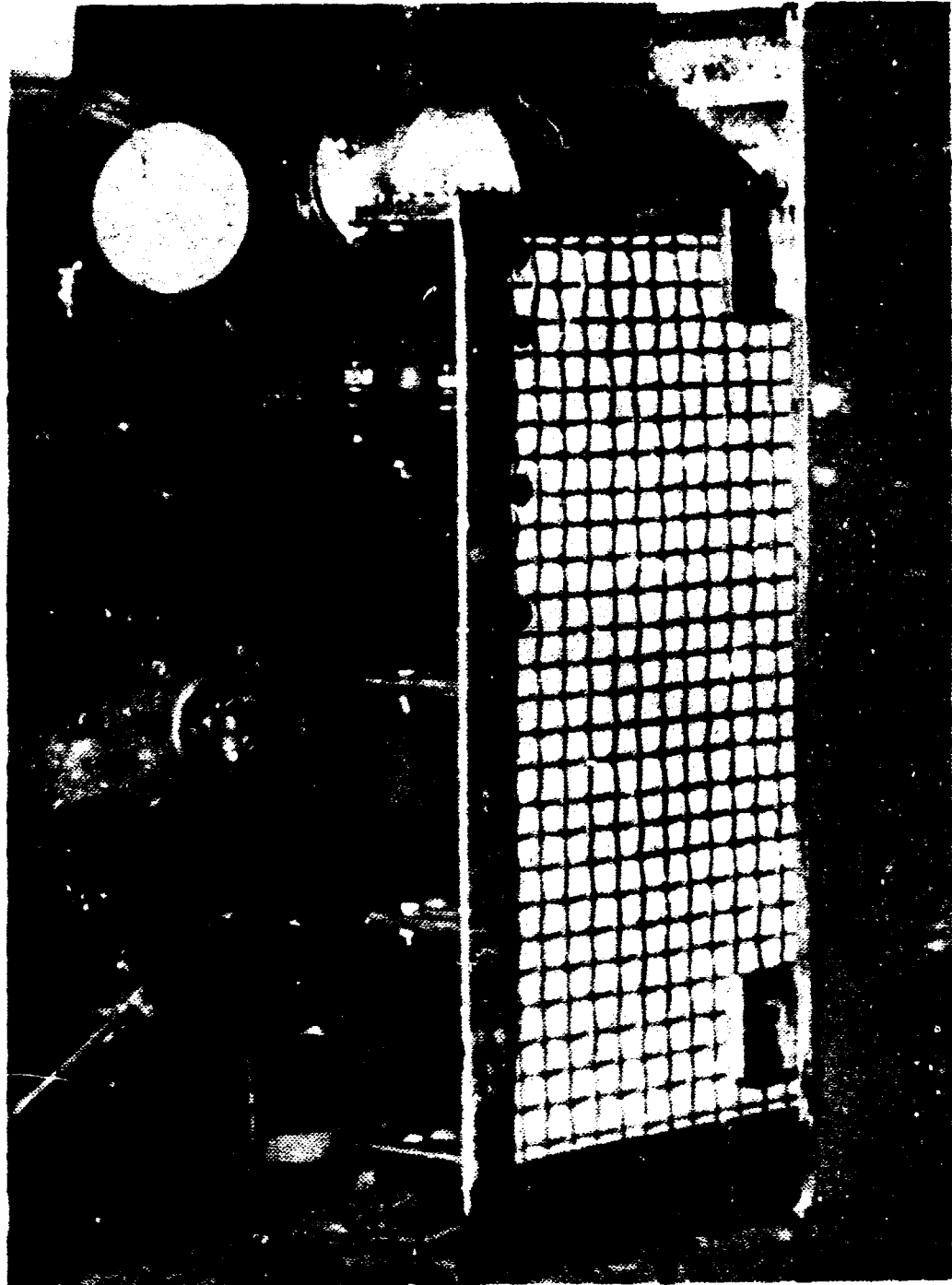

**FIG. 9 HEAT SHIELD DESIGNED AT USNSRDF TO  
OVERCOME EXCESSIVE RADIATION EFFECTS.  
(USNSRDF NEG. NO. RDF-13-i)**

Abnormally high side-wall temperatures, such as indicated by the dull red glow, are caused by large amounts of carbon monoxide or other combustibles being oxidized in the muffler. In order to control the amount of carbon monoxide output of the engine, it is necessary to control the carburetion quite closely over a wide range of operating conditions.

The engine manufacturers set their carburetors to give the proper or as close to correct air-fuel ratios as are consistent with good operating characteristics. On the fork trucks used in these tests, manufactured by Clark and Towmotor, their carburetors are equipped with both idle (low speed) and high speed jets. The idle jets are adjustable on both models, but only the 4,000 lb. Clark machine has an adjustable high speed jet. These are usually set at the factory, as both trained personnel and special equipment is necessary to ~~correctly~~ adjust a carburetor.

Since the muffler manufacturer states that critical control of air-fuel ratio is necessary for the proper functioning of the catalyst, it has been impossible to meet these conditions with any consistency. The required time and trained personnel are not available in the normal maintenance program on fork trucks. Carburetor adjustments are not dependable, as atmospheric and operating conditions vary the air-fuel ratios from day to day.

#### LOW OPERATIONAL HOURS

Safety and maintenance reports from Norfolk for the months of September, October and November showed a very low number of hours on

the machines. An investigation of this matter in late December disclosed the following reasons:

Numerous delays were caused by the special fueling conditions required when using the machines. Regular gas facilities were for leaded gas, and since white gas is the only type permitted in the operation of these machines, a special fueling point was necessary. This point was in the Fuel Depot at Naval Supply Center, where white gas was kept in drums. The gas had to be transferred to five gallon "Blitz" cans and then poured into the fuel tanks of the fork trucks. All gas caps were locked and the keys were in charge of the Fuel Depot supervisor. These complications in obtaining fuel usually deterred operators from using these machines when others were available.

The mufflers failed to operate on occasion, and it was learned that breaks of the manifold flange, similar to those on the original muffler, had occurred. Three machines developed water leaks about the head stud bolts. This was due to fastening muffler brackets to the engine stud bolts.

All of the machines at Norfolk had reconditioned engines. They had seen considerable service and were not in tip-top mechanical shape. This discouraged their use when newer machines were available. The decision to use these machines was based upon a desire to determine whether the CO Eliminator Mufflers could be successfully installed and operated on

trucks already in service and which had previously been run on gasoline containing tetraethyl lead.

The machines at Norfolk were intended for use in the holds of ships. Operational requirements were such that a 6,000# capacity machine was usually placed in the hold along with the 4,000# machine. In order to acquire comparative data on hold operations, it was recommended that three 6,000# machines be equipped with mufflers. When the mufflers arrived in December, an installation was attempted following the muffler manufacturers recommendations. It was impossible to place the mufflers in the horizontal as recommended by the manufacturer. Therefore, in order to install the muffler, it was necessary to turn it on edge (as shown in Figure 10, the only way in which it would fit) and this necessitated dropping the entire steering assembly and removing the radiator drain plug. See Figures 10-13. Installation required about eight man hours per muffler if no problems were encountered. Otherwise, mufflers might require as high as sixteen man hours for installation. The seventy-five hour run-in period on white gas and the close control of the issue of white gas presented problems in scheduling and dispatching.

The Safety Department at Norfolk has commented on the installation of this muffler. They have recommended that the direction of the exhaust outlet be changed so that exhaust gas and the occasional sparks coming out of the muffler opening would be directed toward the floor rather than forward along the side of the engine.



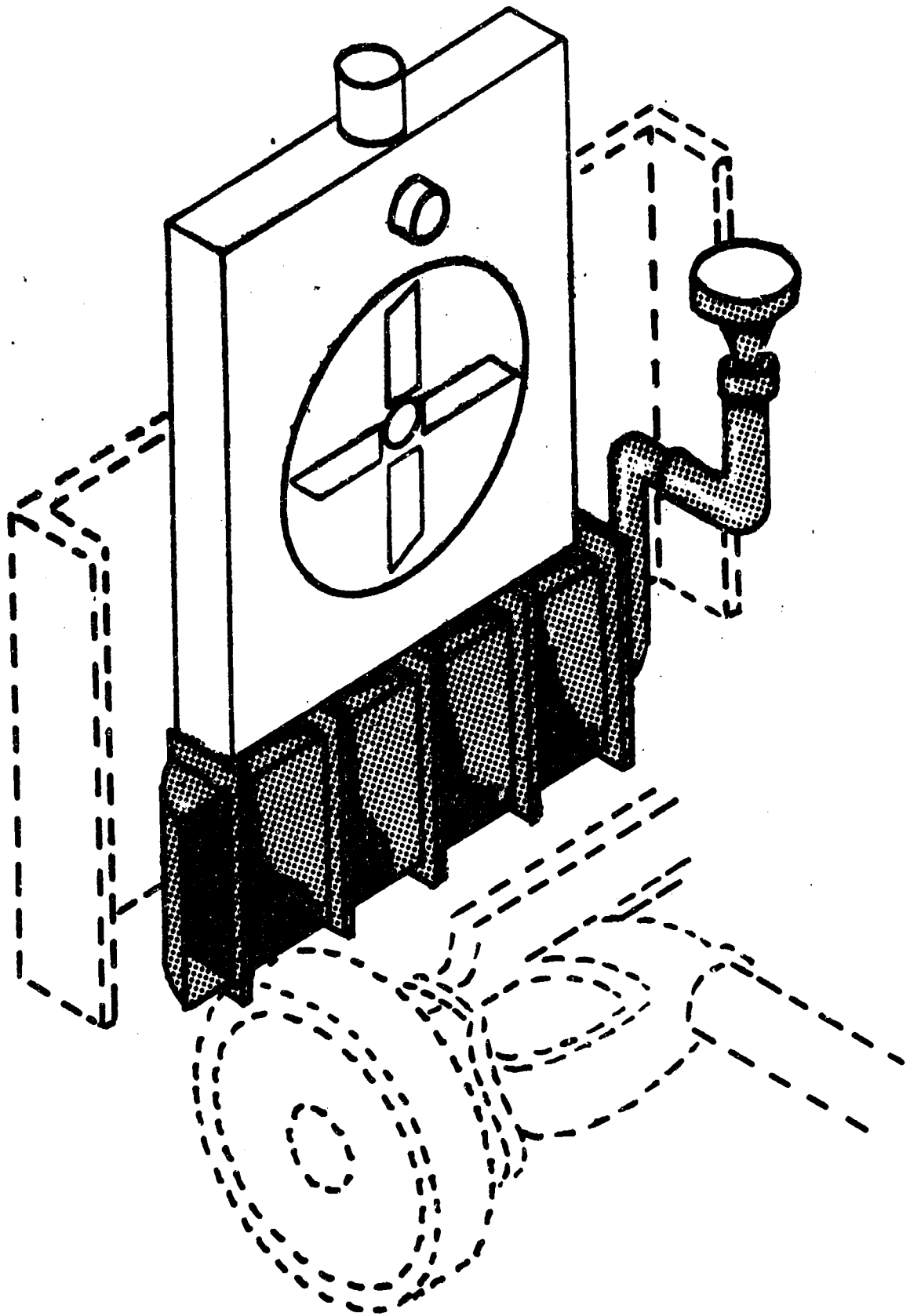

**FIG. 10**

**POSITION OF MUFFLER AS INSTALLED ON 6000 LB. FORK TRUCK.**



FIGURE 11

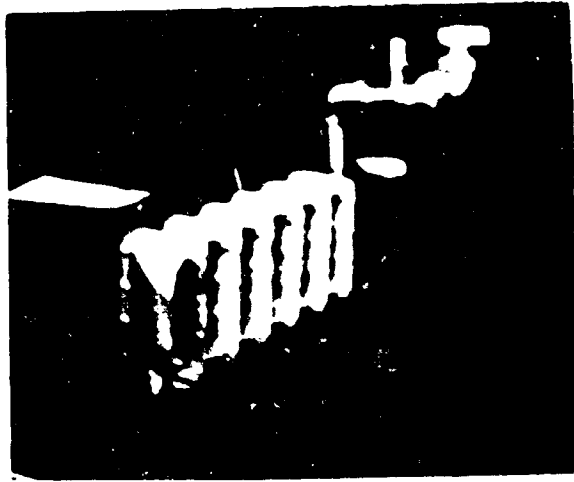

FIGURE 12

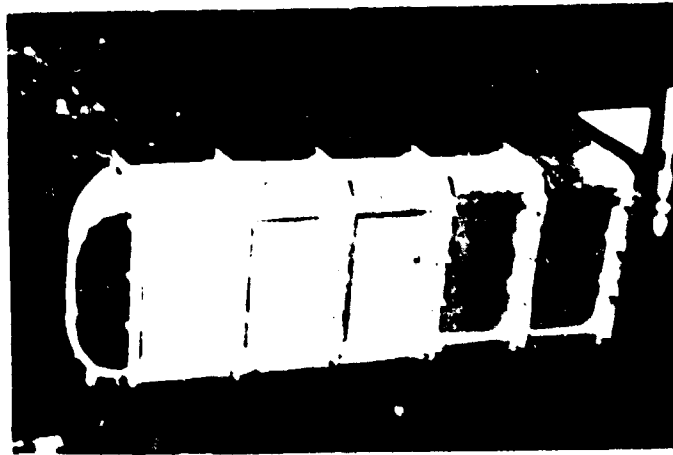

FIGURE 13

FIGS. 11-13 MUFFLERS FOR 6000# FORK TRUCK. AS INSTALLED AND  
ON WORK BENCH IN POSITION OF INSTALLATION.

## INSTALLATION AT BAYONNE

Ten new machines for catalyst muffler tests were received at Bayonne in November. Five of these machines were Towmotor Model LT-48. The other five machines were 4,000# capacity Clark "Carloaders". Attachment of the mufflers to these new trucks proved time consuming and difficult.

The attachment of a muffler to the Clark "Carloader" necessitated the relocation of the carburetor air in-take pipe. See Figure 15. It was directly in the path of the muffler manifold connection. The muffler manufacturer recommended that the muffler be fastened to brackets provided for the truck's original muffler. This was not advisable without increasing the strength of these brackets by means of stiffeners. The clamp provided by the muffler manufacturer to fasten the muffler to the support bracket did not grip the muffler securely. It relied on supporting the muffler without holding it rigidly. See Figure 16. A new clamp was designed, along with the reinforced support bracket, as shown in Figure 17.

## NEW VISUAL ALARM

An audio-visual alarm has been mounted on these five machines incorporating a new circuit design. See Figure 18. The circuit now operates on a thermal switch that is closed until the muffler comes up to temperature. See Figure 19. The closed circuit switch energizes a buzzer and danger lamp that remain on until the thermal switch opens

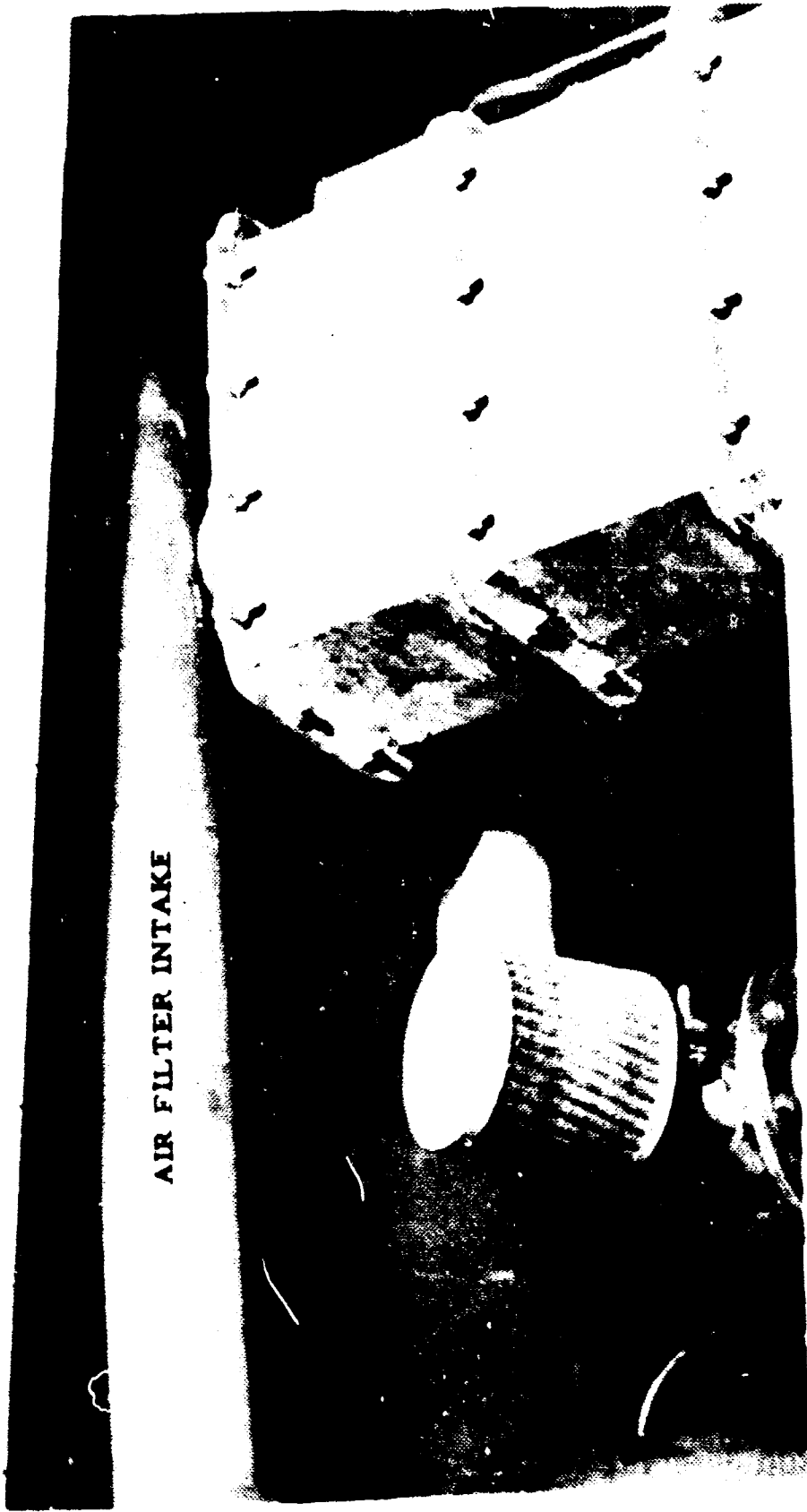

AIR FILTER INTAKE

FIG. 15 INTERFERENCE BETWEEN MUFFLER AND AIR FILTER INTAKE ON CLARK "CARLOADER". (USNSRDF NEG. No. RDF 26-3)

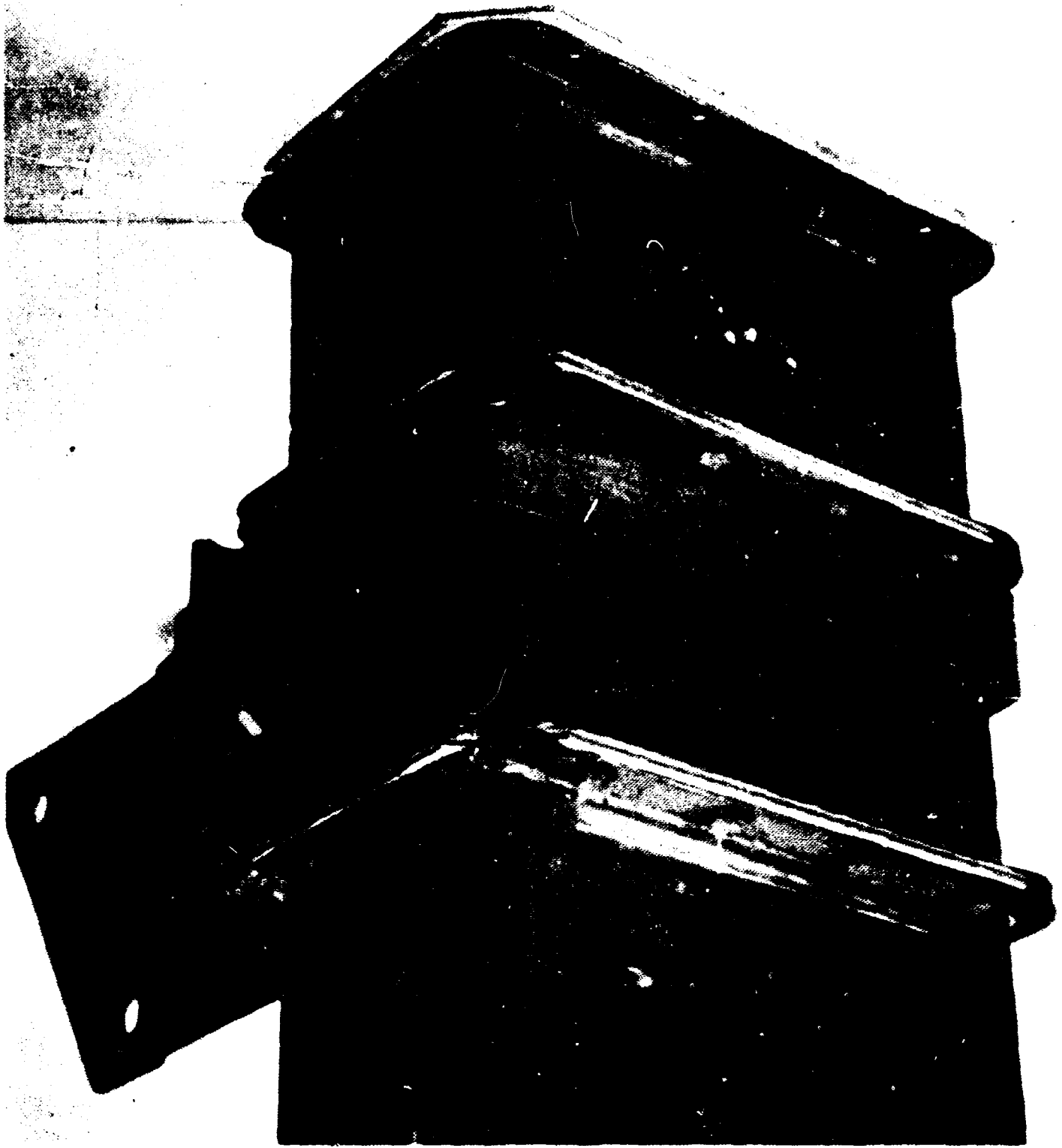

**FIG. 16. MUFFLER SUPPORT BRACKET FURNISHED BY MFR.  
NOTICE GAP BETWEEN CLAMP AND MUFFLER  
(USNSRDF NEG. NO. RDF-26-6.)**

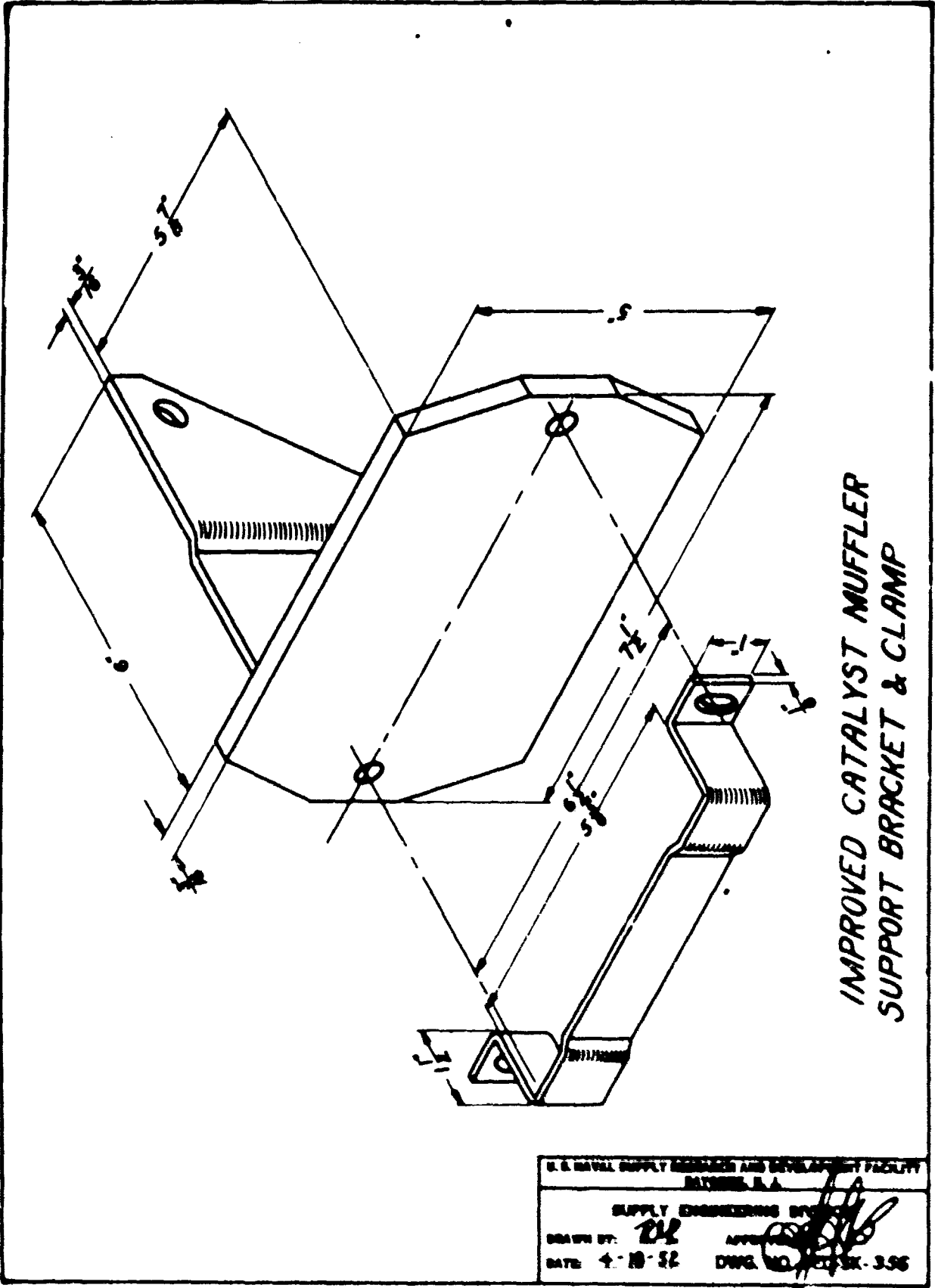
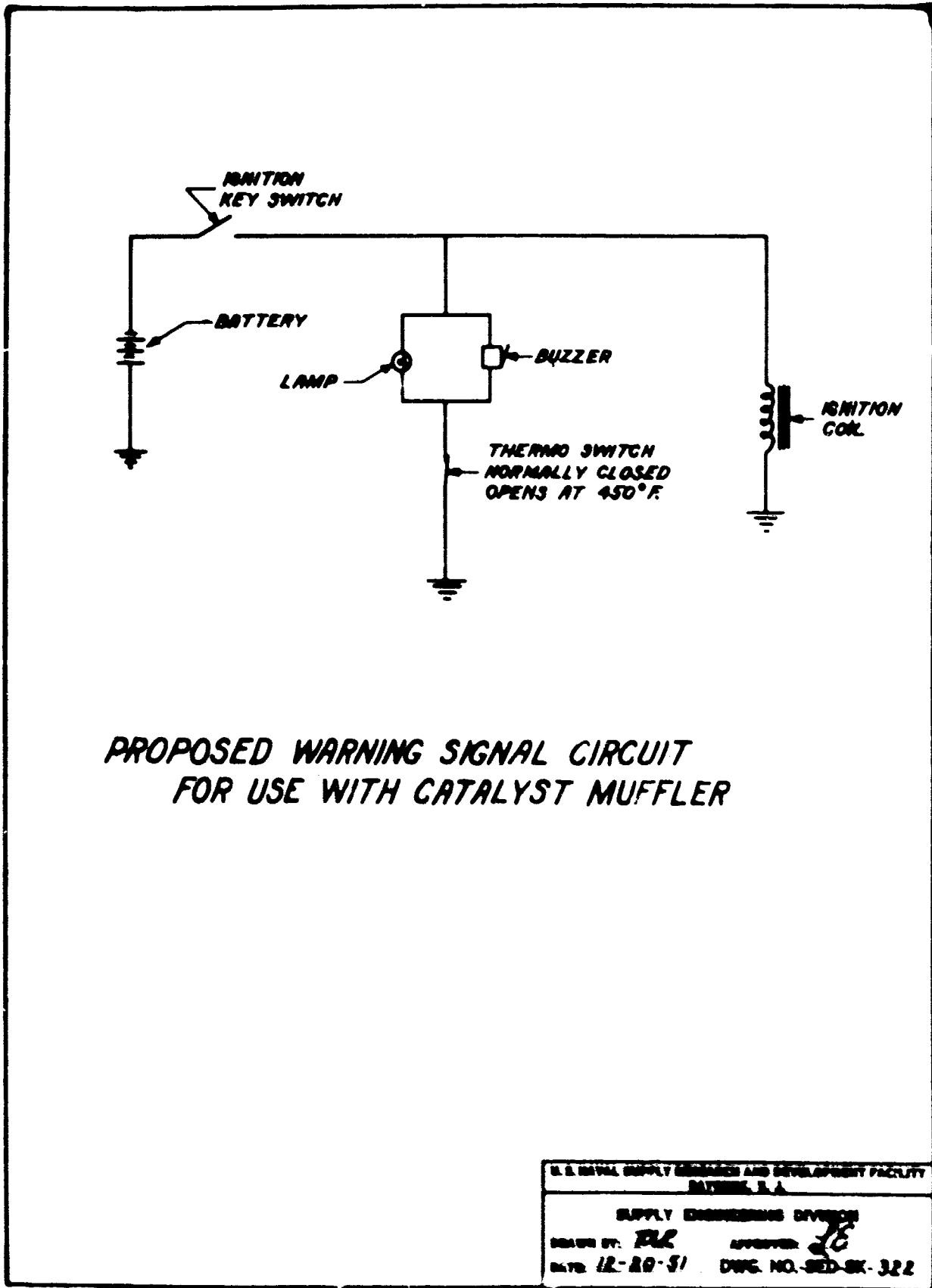

FIG. 17



**FIG. 18 CONTROL CIRCUIT BOX INCORPORATING CIRCUIT OF FIG. 19 AND EXHAUST GAS TEMPERATURE INDICATOR INSTALLED ON CLARK "CARLOADER". (USNSRDF NEG. NO. RDF-26-7)**



**FIG. 19 - REDESIGNED ALARM SYSTEM NOW IN USE.**



and the circuit is broken. This alarm system has been found to operate satisfactorily and will indicate proper muffler operation as long as the engine is not operating continuously under heavy load. Under this condition, the temperature of the exhaust gases may be high enough to keep the alarm off, although the muffler is not operating properly. The Underwriters Laboratory, Inc. confirms this in a report<sup>6/</sup> on the catalyst muffler.

The muffler installed according to manufacturer's recommendation directs the exhaust over the rear steering wheels of the truck. See Figure 20. This is an undesirable condition, as the tire manufacturers do not recommend high temperatures for long life of their tires. The hot exhaust gases represent a fire hazard where oil and grease accumulations are present. The muffler outlets should be connected to the regular exhaust outlets as provided by the fork truck companies.

In the installation of the five mufflers on the Tomotor machines at Bayonne, the difficulties encountered in Norfolk were recalled, and measures taken to forestall them. Heat shields for the side-walls were installed and the new alarm system connected. The method of muffler support caused water leaks about the engine stud bolts on three trucks

---

6/ Underwriters Laboratories, Inc. Report on Catalytic Exhaust Units (Automotive), Automotive 1279, App'n. 5003747, Chicago, Illinois, August, 1951.



FIG. 20 PHOTO OF MUFFLER EXHAUST OUTLET SHOWING PROXIMITY OF STEERING WHEEL. (USNSRDF NEG. NO. RDF-26-4)

which developed immediately after installation. One machine was disassembled and extra long stud bolts placed in the positions where the muffler brackets fasten. The engine head bolts could then be tightened down correctly and the additional length of stud permitted fastening the brackets on top of the nuts and another nut to be run down over this stud. This machine is currently undergoing test. After 40 hours of operation, a flange connection on another muffler broke in a manner similar to that of earlier models. This was welded and the machine placed back into service.

#### OPERATIONAL TESTS AT BAYONNE

Of the machines in operation at Bayonne, one Towmotor has 302 hours of operation on the muffler. Other machines have from 10 to 145 hours, as of 21 February 1952. Due to problems encountered with installation and maintenance on the mufflers, the machines have not been available for sufficient use as to indicate durability of the catalytic elements.

A very noticeable result of operation that may effect the life or durability of these mufflers has been a rattle in the muffler. This rattle is very distinctive and recognizable upon acceleration of the engine. It is believed to be caused by the muffler vibrating with the engine and catalytic section inside the muffler rattling. Whether or not this is detrimental to the life of the catalyst cannot be stated at this time.

Unusual odors, discernable when operating these machines, have led to the belief that the white gas used on these tests may have some constituents not suitable for use with the muffler. Operators have complained about odors which they do not encounter with regular gasoline powered machines. This subject is still under investigation.

#### COMMENTS

The ability of the O.C.M. catalyst muffler to eliminate carbon monoxide from the exhaust gases of fork trucks has been discussed in the two prior reports. Its ability to eliminate the carbon monoxide over a long operational period will be considered in subsequent reports.

This report has covered four of the five basic factors mentioned previously. It has pointed out the concomitant problems encountered with this special muffler.

Ease of adjustment for proper functioning has not been achieved.

Reliability and mechanical design are intimately related; since serious inadequacies in mechanical design have been found, the functional reliability is dubious.

The presence of an alarm system has been stressed by the safety department wherever the machines are in use. A fool-proof, positive alarm system has not been developed.

It is interesting to note that the reaction of the Safety Engineers, both at Norfolk and Bayonne, was not favorable. Their comments seemed to be based upon a feeling that unless the eliminator muffler were proven unfailingly reliable, the hazard of CO would be multiplied through a false sense of security which would result from the mere physical presence of the device. They further commented that this situation could be overcome if a positive and fool-proof alarm system could be devised. This, however, does not appear possible at this time because of the complexity and nature of the devices required to measure CO.