

AD 647384

REPORT NUMBER 132

NOVEMBER 1963

EMPENNAGE STRESS ANALYSIS REPORT

X-15
DIFT FAN FLIGHT RESEARCH AIRCRAFT PROGRAM

CONTRACT NUMBER DA44-177-TC-715

GENERAL  ELECTRIC

ARCHIVE COPY

DDC AVAILABILITY NOTICES

1. Distribution of this document is unlimited.
2. This document is subject to special export controls and each transmittal to foreign governments or foreign nationals may be made only with prior approval of US Army Aviation Materiel Laboratories, Fort Eustis, Virginia 23604.
3. In addition to security requirements which must be met, this document is subject to special export controls and each transmittal to foreign governments or foreign nationals may be made only with prior approval of USAAVLABS, Fort Eustis, Virginia 23604.
4. Each transmittal of this document outside the agencies of the US Government must have prior approval of US Army Aviation Materiel Laboratories, Fort Eustis, Virginia 23604.
5. In addition to security requirements which apply to this document and must be met, each transmittal outside the agencies of the US Government must have prior approval of US Army Aviation Materiel Laboratories, Fort Eustis, Virginia 23604.
6. Each transmittal of this document outside the Department of Defense must have prior approval of US Army Aviation Materiel Laboratories, Fort Eustis, Virginia 23604.
7. In addition to security requirements which apply to this document and must be met, each transmittal outside the Department of Defense must have prior approval of US Army Aviation Materiel Laboratories, Fort Eustis, Virginia 23604.
8. This document may be further distributed by any holder only with specific prior approval of US Army Aviation Materiel Laboratories, Fort Eustis, Virginia 23604.
9. In addition to security requirements which apply to this document and must be met, it may be further distributed by the holder only with specific prior approval of US Army Aviation Materiel Laboratories, Fort Eustis, Virginia 23604.

DISCLAIMER

10. The findings in this report are not to be construed as an official Department of the Army position unless so designated by other authorized documents.
11. When Government drawings, specifications, or other data are used for any purpose other than in connection with a definitely related Government procurement operation, the United States Government thereby incurs no responsibility nor any obligation whatsoever; and the fact that the Government may have formulated, furnished, or in any way supplied the said drawings, specifications, or other data is not to be regarded by implication or otherwise as

in any manner licensing the holder or any other person or corporation, or conveying any rights or permission, to manufacture, use, or sell any patented invention that may in any way be related thereto.

12. Trade names cited in this report do not constitute an official endorsement or approval of the use of such commercial hardware or software.

DISPOSITION INSTRUCTIONS

13. Destroy this report when no longer needed. Do not return it to originator.

14. When this report is no longer needed, Department of the Army organizations will destroy it in accordance with the procedures given in AR 380-5.

ACCESSION NO.	
CFSTI	WHITE SECTION <input checked="" type="checkbox"/>
...	DIFF SECTION <input type="checkbox"/>
ANNOUNCED	<input type="checkbox"/>
CLASSIFICATION	
DISTRIBUTION/AVAILABILITY CODES	
DIST.	AVAIL. and/or SPECIAL
1	

Report No. 132

Empennage Stress Analysis Report

XV-5A Lift Fan
Flight Research Aircraft Program

November 1963

DDC
RECEIVED
MAR 2 1967
A
13

ADVANCED ENGINE AND TECHNOLOGY DEPARTMENT
GENERAL ELECTRIC COMPANY
CINCINNATI, OHIO 45215

7 APR 1966
MF

CONTENTS

SECTION		PAGE
I.	INTRODUCTION	1
II.	HORIZONTAL STABILIZER	2
	Shear & B. M Curves	4
	Torque Curves	5
	Attachment Loads	6
	Spar Cap Areas & Allowables	9
	Bending Stresses & Shear Flows	17
	BL 3.26	17
	BL 16.56	27
	BL 29.96	33
	BL 29.97	39
	BL 36.66	45
	BL 50.60	53
	BL 70.16	57
	Summary Spar Cap M. S.	63
	Spar Shear Analysis	64
	Hinge Ribs	67
	Actuator Support Fitting	70
	Horizontal Stab. Pivot Fitting	72
III.	ELEVATOR	74
	Loading	75
	Hinge Loads	82
	Shear & B. M. Diagram	83
	Bending Check	84
IV.	VERTICAL STABILIZER	85
	Load Curves	88
	Spar Cap Areas & Allowables	91
	Bending Stresses & Shear Flows	96
	V. S. STA. 13.4	96
	V. S. STA. 27.0	102
	V. S. STA 40.6	108

SECTION		PAGE
	V. S. STA. 54.2	114
	V. S. STA. 67.8	120
	Summary of Spar Cap M. S.	126
	Spar Shear Analysis	127
	Pivot Fitting	128
	Horiz. Stab. Actuator Spt. Ftg.	133
V.	RUDDER	135
	Loading	136
	Hinge Loads	136
	Shear & B. M Diagrams	136
	Bending Analysis	137
	Shear Analysis	138

I. INTRODUCTION

This report presents the stress analysis of the Model XV-5A empennage. The structure analyzed includes the horizontal and vertical stabilizers, and the elevator and rudder. The analyses, which are intended to provide summary type information, include critical loading data; computation of internal stresses and shears, and brief detailed analyses to find margins of safety of the major components.

The empennage has been successfully proof tested to limit load. Conditions F-12 and F-13 were combined to produce the critical symmetrical condition. The critical unsymmetrical rolling moment of condition AF-6 was applied during the fuselage unsymmetrical test condition.

All loads shown in this report are ultimate values, unless otherwise stated.

MIL HDBK-5 is used for material mechanical properties and fastener allowances. Other references are given where first used.

II. HORIZONTAL STABILIZER

Description of Structure

The horizontal stabilizer is a three-spar semi-monocoque structure. The front spar ends at B. L. 29.96. The magnesium cover skin is stiffened by ribs only. The horizontal stabilizer is mounted on the tip of the vertical stabilizer by three fittings; the symmetrical pivot fittings @ the center spar and B. L. ±6 and the actuator support fitting @ the centerline of the front spar. The incidence is varied by rotation about the pivot fittings.

Critical Conditions - The following three conditions are analyzed,

F-12 - max. shear & B. M.

(sym. maneuver, $\ddot{\theta} = 3.0$, $n_z = -2.0$, mach 0.8)

F-13 - max. torque

(sym. maneuver, $\ddot{\theta} = 0$, $n_z = +4.0$, mach 0.285)

AF-6 - max. unsymmetrical loading

(asym. flight, dyn. overwing, $n_z = 1.0$, mach 0.756)

Loading curves for conditions F-12 and F-13 are shown on pages 4 and 5.

Method of Analysis

Bending stresses and shear flows are calculated at several stations from conventional engineering theory by digital computer program. This program is described in Ryan Report 62B118, "Description of Box Beam Program for IBM, Job No. 1012", 18 Nov. 1962. The format of the IBM output is described on page 23 of report 62B118.

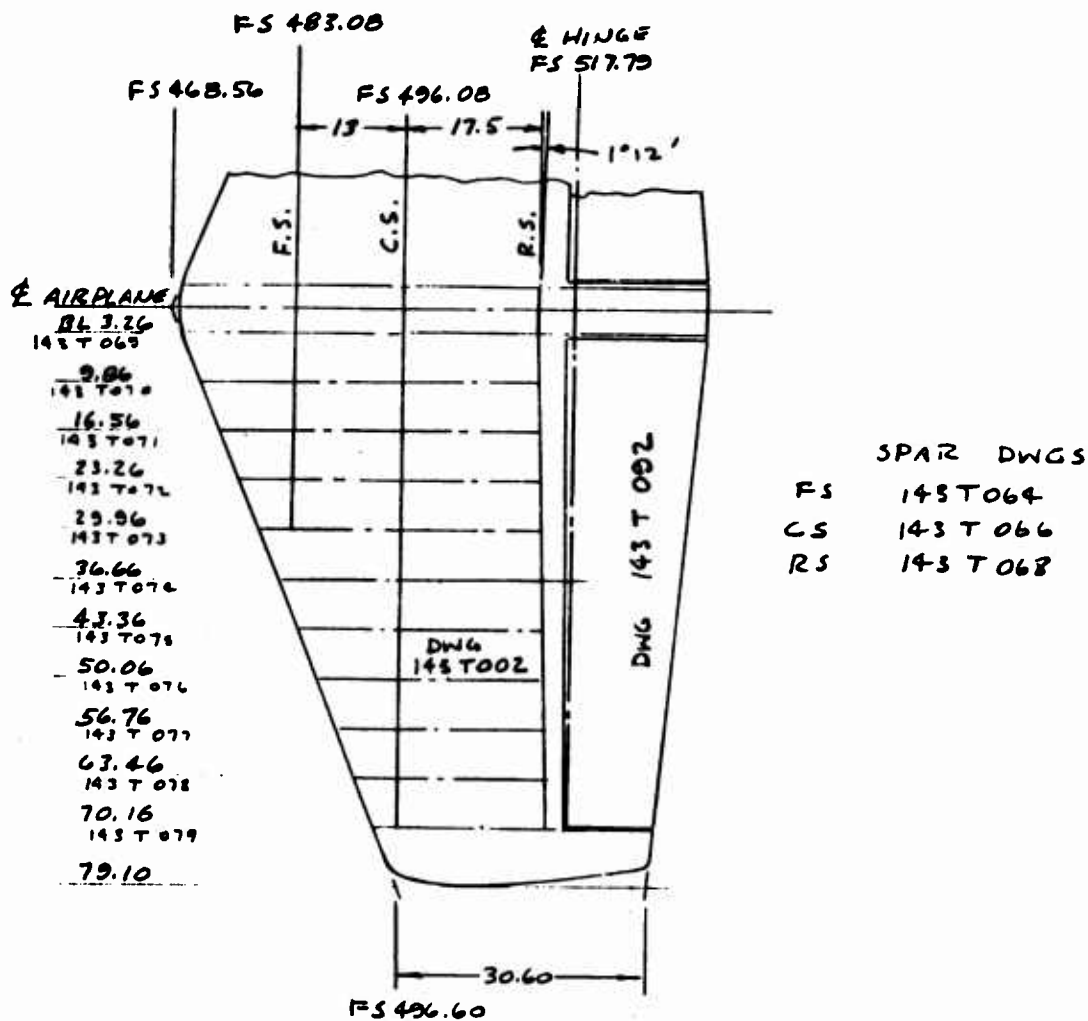

HORIZONTAL STABILIZER
 REF. DWG. 143T004

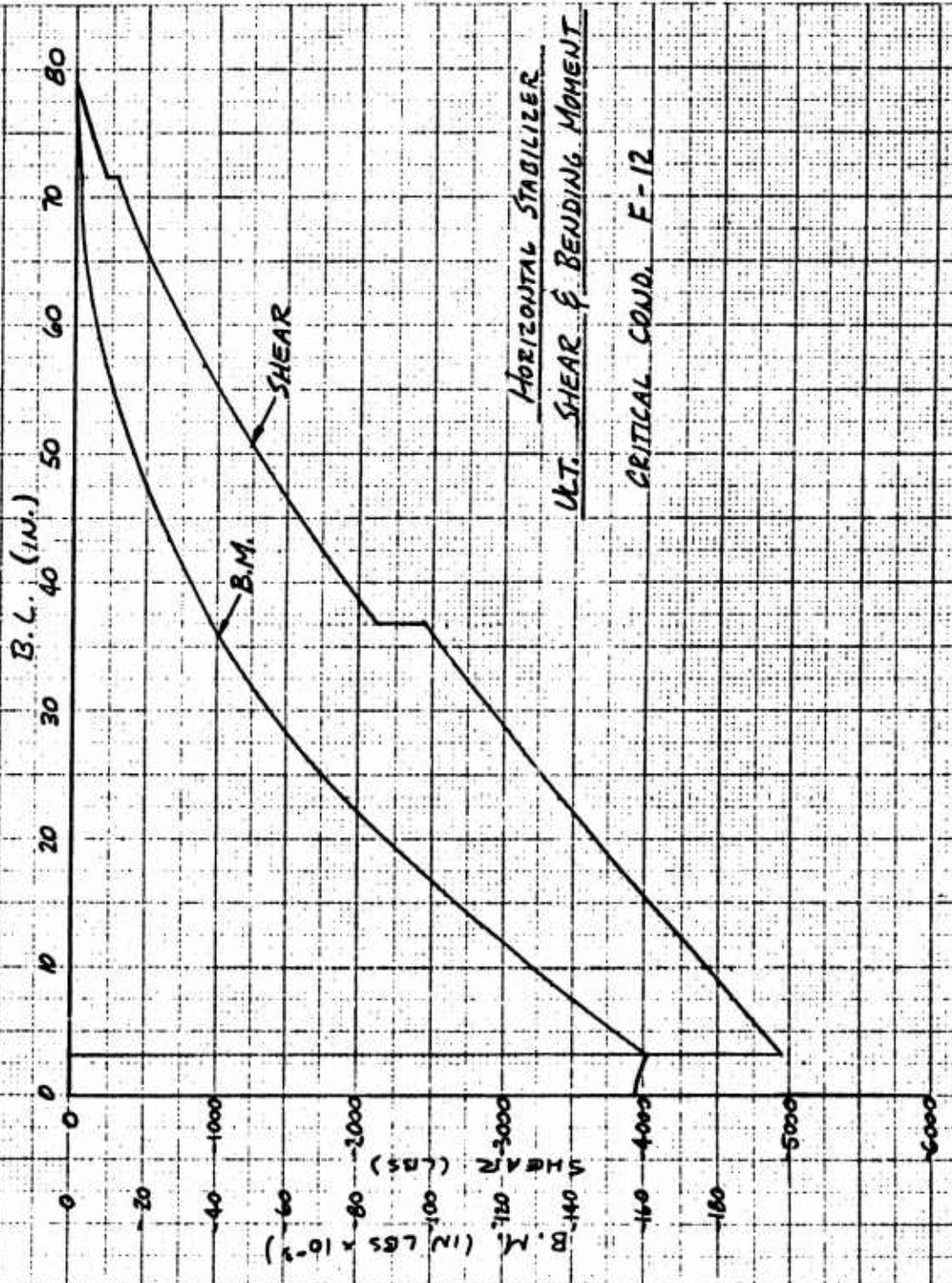

HORIZONTAL STABILIZER
 ULT. SHEAR & BENDING MOMENT

CRITICAL COND. F-12

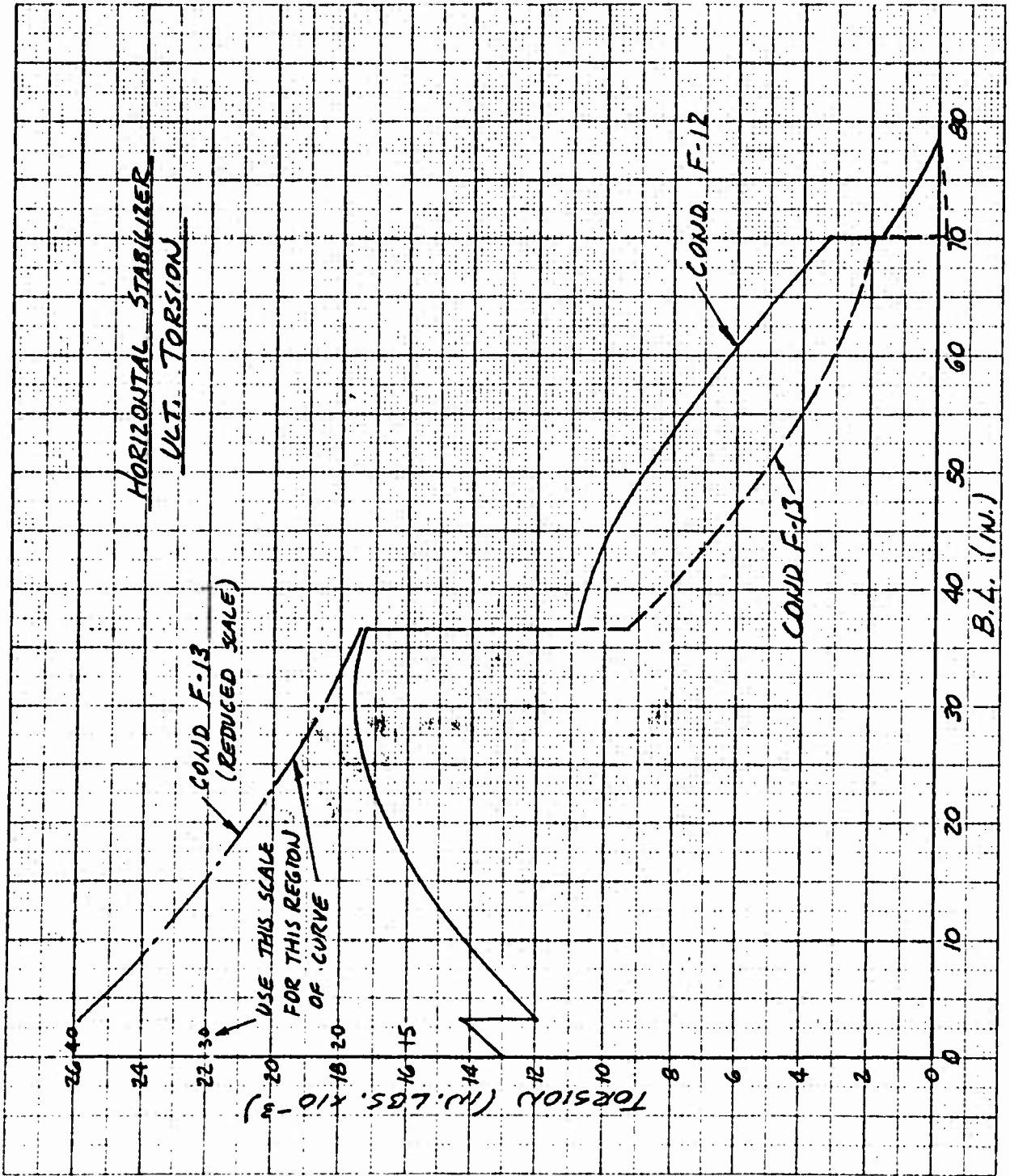

Sambert
7/17/63

HORIZONTAL STABILIZER

ATTACHMENT LOADS

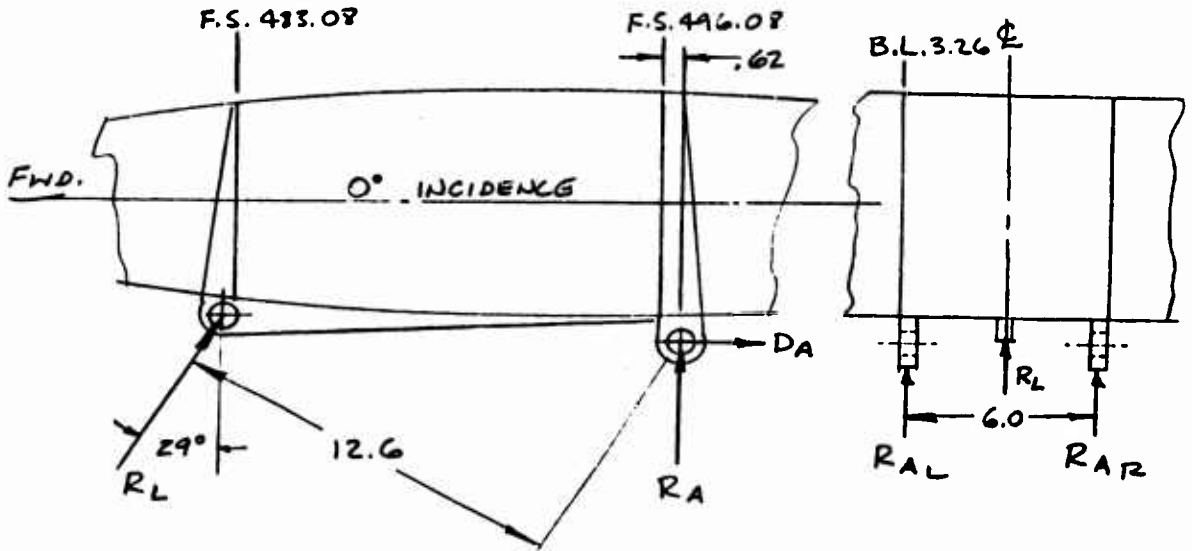

COND. F-12 - MAX SHEAR CONDITION

$$\text{TOTAL SHEAR} = -10653 \# \quad \text{ULT.}$$

$$T (\text{ABOUT FS } 496.08) = 25900 \text{ "}\# \quad \text{ULT.}$$

$$T (\text{ABOUT PIVOT}) = 25900 - 10653 \times .62 = 19290 \text{ "}\#$$

$$R_L = 19290 / 12.6 = -1530 \# \quad (\text{TENSION IN ACT.})$$

$$R_{Lz} = 1530 \cos 29^\circ = -1338 \#$$

$$R_{Lx} = 1530 \sin 29^\circ = -740 \#$$

$$R_A = (10653 + 1338) \cdot .5 = 5996 \#$$

$$D_A = 740 \cdot .5 = 370 \#$$

Lambert
7/17/63

HORIZONTAL STABILIZER

COND F-13 - MAX. TORQUE CONDITION

$$\text{TOTAL SHEAR} = 1280 \#$$

$$T (\text{ABOUT FS } 496.08) = 89950 \# \#$$

$$\begin{aligned} T (\text{ABOUT PIVOT}) &= 89950 + 1280 \times 1.62 \\ &= 90740 \# \# \end{aligned}$$

$$R_L = \frac{90740}{12.6} = 7200 \#$$

NOTE: STABILIZER INCIDENCE ACTUATOR AND ATTACHMENT FITTINGS ARE DESIGNED FOR 7500 # ULT. TENSILE LOAD.

COND AF-6 - MAX. UNSYMMETRICAL LOADING

$$\text{TOTAL SHEAR} = -6188 \# \quad @ \text{ F.S. } 505.55$$

$$\text{UNSYM. MOMENT } (M_x) = 101780 \# \#$$

$$T_{\text{PIVOT}} = 6188(505.55 - 496.7) = 54700 \# \#$$

$$\text{VERT. COMP. OF ACT. LOAD} = \frac{54700}{12.6} \cos 29^\circ = 3800 \#$$

$$R_{AL} = \frac{3800 + 6188}{2} + \frac{101780}{6} = 21970 \#$$

$$R_{AR} = \frac{3800 + 6188}{2} - \frac{101780}{6} = -11990 \#$$

Sambut
7/17/63

HORIZONTAL STABILIZER

COND AF-6

NET LOADS INB'D PIVOT FTG.

3800 * COMP. OF ACTUATOR LOAD IS BEAMED EQUALLY TO BL 3.26 RIBS BY LOCAL BENDING OF FRONT SPAR (NO RIB @ $\frac{1}{2}$).

FOLLOWING DISTRIBUTION OF -6188 * SHEAR IS ASSUMED:

-4520 * LEFT SIDE } C.P. @ BL 55.76
-1668 * RT. SIDE }

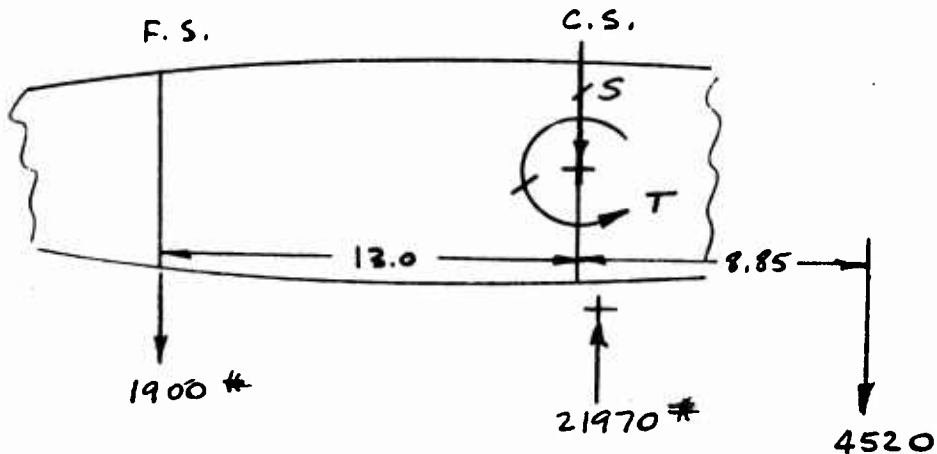

$$S = 21970 - 1900 - 4520 = 15550 *$$

$$T = 4520 \times 8.85 - 1900 \times 13 - 21970 \times .62 = 1700 " *$$

Lambert
6/27/63

HORIZONTAL STABILIZER
(DWG. 143T002)

FRONT SPAR CAP AREAS (DWG. 143T064)

CONSTANT B.L. 0 TO B.L. 9.86

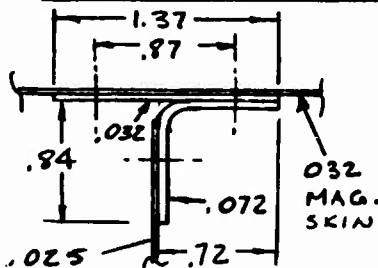

EQUIVALENT SKIN, $t_c = t_{MAG} \frac{E_{MAG}}{E_{AL}}$

$$t_c = .032 \times \frac{6.5}{10.5} = .020$$

ASSUME EFF. WIDTH = $15t$ (EACH SIDE OF RIV.)

AREAS:

$$\text{ANGLE} = .072 (.768 + .648) = .102$$

$$\text{STRAP} = 1.37 \times .032 = .0439$$

$$\text{SKIN} = 3 \times 15 \times .02 \times .02 = .018$$

$$\text{WEB} = (.31 + 15 \times .025) \times .025 = .0171$$

$$\text{TOTAL} = .181$$

ALLOWABLE CRIPPLING STRESS - .072 7075-T6 ANGLE
(REF. RYAN STRUCTURES MANUAL)

$$\frac{b'}{t} = \frac{.804 + .684}{2 \times .072} = 10.3$$

$$\frac{F_{cc}}{\sqrt{F_{cy} E}} = .054$$

$$F_{CR} = .054 \sqrt{F_{cy} E}$$

$$= .054 \sqrt{10.5 \times 10^6 \times 68000}$$

$$= 45600 \text{ psi}$$

Lambert
6/27/63

HORIZONTAL STABILIZER

FRONT SPAR CAP AREAS

B.L. 16.56

THICKNESS OF ANGLE TAPERS FROM .071 @
BL 9.86 TO .035 @ B.L. 29.96

$$t @ B.L. 16.56 = .059$$

$$AREA OF ANGLE = .059(.78 + .66) = .085$$

$$TOTAL AREA = .164$$

ALLOWABLE CRIPPLING STRESS

$$\frac{b'}{t} = \frac{.81 + .69}{2 \times .059} = 12.7$$

$$F_{cr} = .046 \sqrt{10.5 \times 10^6 \times 68000}$$
$$= 38900 \text{ psi}$$

3
Cumbert
6/27/63

HORIZONTAL STABILIZER

CENTER SPAR CAP AREAS (DWG. 143T066)

SECTION @ B.L. 3.26

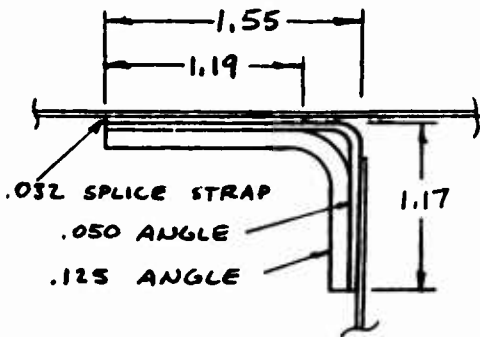

EFFECTIVE SKIN AREA ACTING WITH CENTER SPAR IS INCLUDED BY COMPUTER.

WEB IS SPLICED AT THIS STATION, \therefore CONSIDERED NOT EFFECTIVE.

AREAS :

$$\begin{aligned} .050 \text{ ANGLE} &= .050 (1.5 + 1.12) = .131 \\ .125 \text{ ANGLE} &= .125 (1.375 + .995) = .296 \\ .032 \text{ STRAP} &= 1.19 \times .032 = .038 \\ & \underline{\underline{.465}} \end{aligned}$$

ALLOWABLE CRIPPLING STRESS

$$\frac{b'}{t} = \frac{1.437 + 1.057}{2 \times .125} = 10$$

$$\frac{F_{cc}}{\sqrt{F_{cy} E}} = .056$$

$$\begin{aligned} F_{cr} &= .056 \sqrt{10.5 \times 10^6 \times 68000} \\ &= 47400 \text{ psi} \end{aligned}$$

4

Sambut
6/27/63

HORIZONTAL STABILIZER

CENTER SPAR CAP AREAS

THICKNESS OF NESTED ANGLE TAPERS FROM .125
@ BL 3.26 TO .050 @ BL 35.98 (END OF PART)

SECTION @ BL 16.56

WIDTH = 1.0 DEPTH = .99 THICKNESS = .095

.050 ANGLE,	$A = .050 (.95 + .94) = .0945$
NESTED ANGLE,	$A = .095 (.855 + .845) = .1613$
EFF. WEB (.032)	$A = (.31 + 15 \times .032) .032 = .0252$
	<u>.2810</u>

$$\frac{b'}{t} = \frac{.902 + .892}{2 \times .095} = 9.45$$

$$F_{cr} = .058 \sqrt{10.5 \times 10^6 \times 68000}$$

$$= 49100 \text{ psi}$$

SECTION @ B.L. 29.96

WIDTH = .72 DEPTH = .78 THICKNESS = .064

.050 ANGLE,	$A = .050 (.67 + .73) = .070$
NESTED ANGLE,	$A = .064 (.606 + .666) = .0815$
EFF. WEB	$A = (.31 + 15 \times .032) .032 = .0252$
	<u>.1767</u>

$$\frac{b'}{t} = \frac{.638 + .698}{2 \times .064} = 10.4$$

$$F_{cr} = .054 \sqrt{10.5 \times 10^6 \times 68000}$$

$$= 45600 \text{ psi}$$

Sambax
6/27/63

HORIZONTAL STABILIZER

CENTER SPAR CAP AREAS

B. L. 36.66 OUTB'D

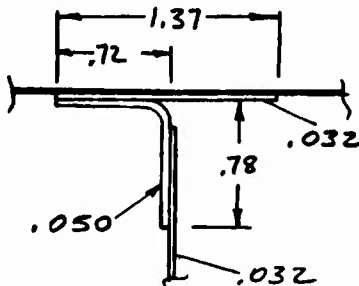

AREA

.050 ANGLE,	$A = .05 (1.67 + .73) = .070$
.032 STRAP,	$A = .032 \times 1.37 = .0439$
EFF. WEB,	$A = (.31 + 15 \times .032) .032 = .0252$
	<u>.1391</u>

ALLOWABLE CRIPPLING STRESS

$$\frac{b'}{t} = \frac{.695 + .755}{2 \times .050} = 14.5$$

$$F_{cr} = .042 \sqrt{10.5 \times 10^6 \times 68000}$$
$$= 35600 \text{ psi}$$

Lambert
6/28/63

HORIZONTAL STABILIZER

REAR SPAR CAP AREAS (DWG. 143 T 068)

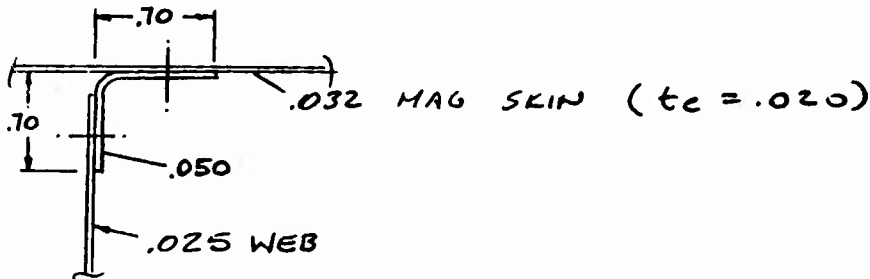

ABOVE SECTION IS CONSTANT FROM BLD TO TIP

AREA :

$$\begin{aligned} .050 \text{ ANGLE, } & A = .050 \times 2 \times .65 = .065 \\ \text{EFF SKIN AFT RIVET, } & A = 15 \times .020 \times .020 = .006 \\ \text{EFF WEB, } & A = (.25 + 15 \times .025) \times .025 = .016 \\ & \underline{\underline{.087}} \end{aligned}$$

ALLOWABLE CRIPPLING STRESS

$$\frac{b'}{t} = \frac{.675}{.05} = 13.5$$

$$\begin{aligned} F_{cr} &= .045 \sqrt{F_{cy} E} \\ &= .045 \sqrt{68000 \times 10.5 \times 10^6} \\ &= 38100 \text{ psi} \end{aligned}$$

Lambert
6/28/63

HORIZONTAL STABILIZER

SECTIONS FROM B.L. 0 TO B.L. 29.96 INBD

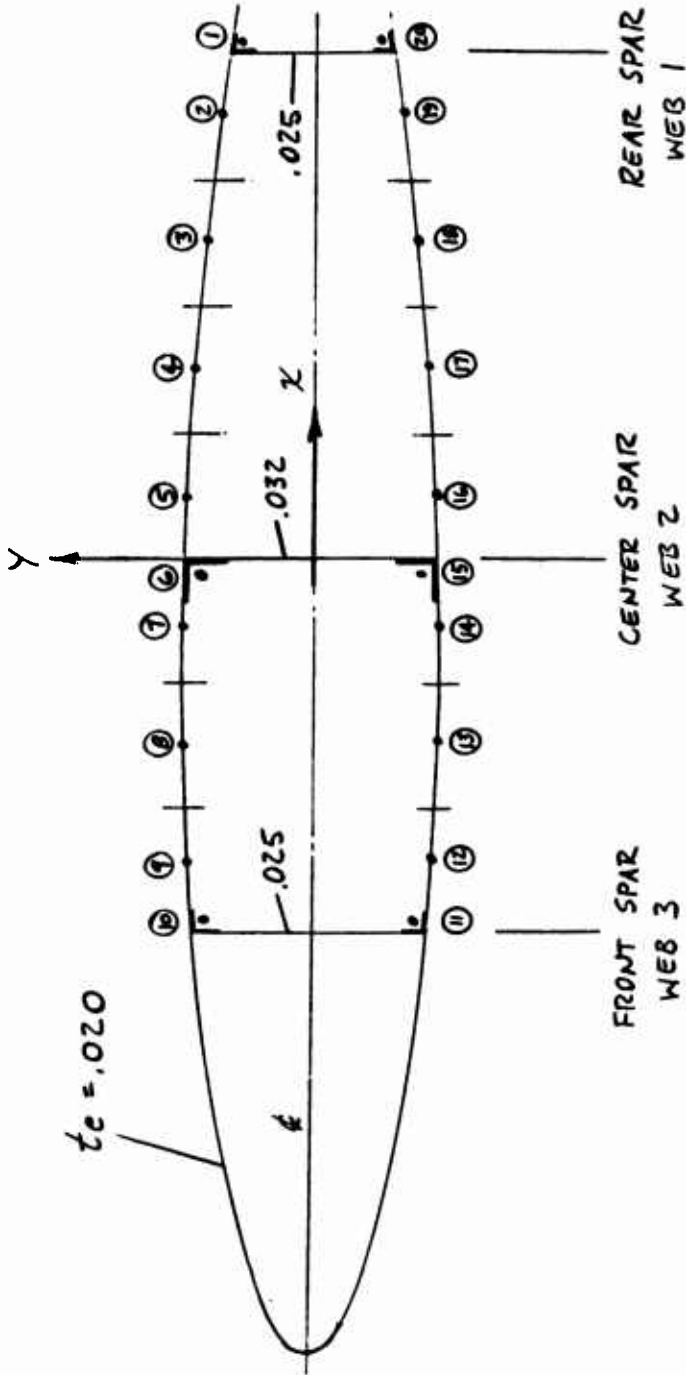

$$.032 \text{ MAG SKIN } t_c = .032 \times \frac{6.5}{10.5} = .020$$

EFFECTIVE SKIN IS DIVIDED INTO SEGMENTS.
ONLY SKIN EFFECTIVE IN TENSION IS USED
BY DIGITAL COMPUTER PROGRAM

Sambert
6/28/63

HORIZONTAL STABILIZER

SECTIONS FROM B.L. 29.96 OUTB'D

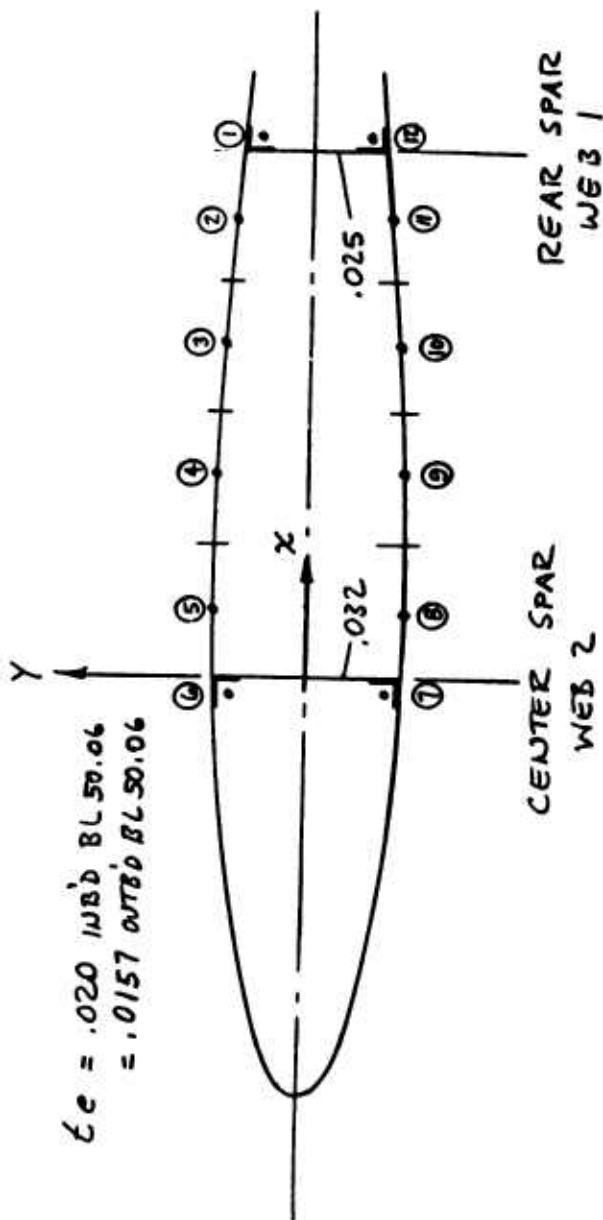

$t_c = .020$ INB'D BL 50.06
 $= .0157$ OUTB'D BL 50.06

JOB NO. 1012

BOX BEAM ANALYSIS
MODEL XV-5A
HORIZONTAL TAIL
STATION 3.26

22 AUG 63

SECTION INPUT DATA

WIDTH TOL.	R(STG)	R(PLATE)	W/T	G/IE6	
0.050	1.000	1.000	20.00	3.900	
C	XO/C	R(WEB)	ZA(TE)	DS(TE)	
43.70	0.6000	1.000	0.	0.	
T(TE)	ZA(LE)	DS(LE)	T(LE)		
0.	120.00	28.000	0.0200		
FP(MAX)	FP(MIN)	FS(MIN)	QP(MAX)		
45000.	-30000.	-40000.	320.		
WEB	XW(U)	YW(U)	XW(L)	YW(L)	TW
1	17.50	2.53	17.50	-2.53	0.0250
2	0.	3.83	0.	-3.83	0.0320
3	-13.00	3.37	-13.00	-3.27	0.0250

JOB NO. 1012

BOX BEAM ANALYSIS
 MODEL XV-5A
 HORIZONTAL TAIL
 STATION 3.26

22 AUG 63

SECTION INPUT DATA

ITEM	X(S)	Y(S)	A(S)	IXOS	IYOS	IXYOS	X(P)	Y(P)	TIP)	E/1E6
1	17.75	2.28	0.09	-0.	-0.	-0.	17.50	2.53	0.020	10.50
2	15.27	2.80	0.	-0.	-0.	-0.	15.27	2.80	0.020	0.
3	10.88	3.22	0.	-0.	-0.	-0.	10.88	3.22	0.020	0.
4	6.52	3.56	0.	-0.	-0.	-0.	6.52	3.56	0.020	0.
5	2.19	3.79	0.	-0.	-0.	-0.	2.19	3.79	0.020	0.
6	-0.35	3.53	0.46	-0.	-0.	-0.	0.	3.83	0.020	10.50
7	-2.20	3.86	0.	-0.	-0.	-0.	-2.20	3.86	0.020	0.
8	-6.53	3.74	0.	-0.	-0.	-0.	-6.53	3.74	0.020	0.
9	-10.82	3.53	0.	-0.	-0.	-0.	-10.82	3.53	0.020	0.
10	-12.75	3.12	0.18	-0.	-0.	-0.	-13.00	3.37	0.020	10.50
11	-12.75	-3.12	0.18	-0.	-0.	-0.	-13.00	-3.37	0.020	10.50
12	-10.82	-3.53	0.	-0.	-0.	-0.	-10.82	-3.53	0.020	0.
13	-6.53	-3.74	0.	-0.	-0.	-0.	-6.53	-3.74	0.020	0.
14	-2.20	-3.86	0.	-0.	-0.	-0.	-2.20	-3.86	0.020	0.
15	-0.35	-3.53	0.46	-0.	-0.	-0.	0.	-3.83	0.020	10.50
16	2.19	-3.79	0.	-0.	-0.	-0.	2.19	-3.79	0.020	0.
17	6.52	-3.56	0.	-0.	-0.	-0.	6.52	-3.56	0.020	0.
18	10.88	-3.22	0.	-0.	-0.	-0.	10.88	-3.22	0.020	0.
19	15.27	-2.80	0.	-0.	-0.	-0.	15.27	-2.80	0.020	0.
20	17.75	-2.28	0.09	-0.	-0.	-0.	17.50	-2.53	0.020	10.50

JOB NO. 1012

BOX BEAM ANALYSIS
MODEL XV-5A
HORIZONTAL TAIL
STATION 3.26

22 AUG 63

CONDITION F-12

SX -4950.	SY -0.	MXX -161000.	MYY -0.	T 11900.
	NO. IT. 3	QXP(N) 0.00001	QYP(N) 0.	
IX(NA) 2.18334E 01	IY(NA) 1.67276E 02	IXY(NA) 3.86342E 00	XBAR -2.08473E-01	YBAR 9.76302E-01
IX(NA)F 2.18331E 01	IY(NA)F 1.67273E 02	IXY(NA)F 3.86397E 00	XBARF -2.08548E-01	YBARF 9.76335E-01
AP(EFF) 6.35885E-01	AP(FULL) 1.22276E 00	A(TRUE) 3.78638E 00	2A(CELLS) 5.44888E 02	
	THETA X (RADIAN) 3.64188E-05	THETA Y (RADIAN) -0.	THETA T (RADIAN) 4.66374E-05	
	S.C.(X) -1.87730E 00	S.C.(X/C) 5.57041E-01	S.C.(Y) 0.	

NET WEB AND INTERNAL CELL SHEAR FLOWS

WEB 1	163.8724
CELL 1	163.8724
WEB 2	-401.1194
CELL 2	564.9917
WEB 3	-162.6290
CELL 3	-3.0886

JOB NO. 1012

BOX BEAM ANALYSIS
 MODEL XV-5A
 HORIZONTAL TAIL
 STATION 3.26

22 AUG 63

CONDITION F-12

ITEM	WP(EFF)	F(P)	F(S)	QP(NET)
WEB 1				163.8724
1	1.1231	8475.06	6581.20	140.0045
2	3.3282	10855.66	10855.66	116.7502
3	4.3916	14716.37	14716.37	77.0295
4	4.3547	17979.59	17979.59	28.9016
5	3.2632	20423.20	20423.20	-11.5656
WEB 2				389.5538 *
6	2.1953	21093.95	18932.50	90.4080
7	3.2659	21692.37	21692.37	46.7706
8	4.3137	21544.45	21544.45	-10.3753
9	3.2405	20723.29	20723.29	-51.9334
10	1.0929	19911.46	18017.60	-165.7176
WEB 3				-165.7176
11	0.3181	-29994.06	-28185.73	-2.9781
12	0.	-31551.63 **	-31551.63	-2.9781
13	0.	-33840.31 **	-33840.31	-2.9781
14	0.	-35469.44 **	-35469.44	-2.9781
15	0.5837	-35623.60 **	-33342.42	486.4913 *
WEB 2				85.3719
16	0.	-35702.00 **	-35702.00	85.3719
17	0.	-34739.60 **	-34739.60	85.3719
18	0.	-32967.84 **	-32967.84	85.3719
19	0.	-30608.87 **	-30608.87	85.3719
20	0.3235	-28991.10	-27182.77	163.8724
WEB 1				0.0000

* VALUE IS GREATER THAN MAXIMUM
 ** VALUE IS LESS THAN MINIMUM

JOB NO. 1012

BOX BEAM ANALYSIS
MODEL XV-5A
HORIZONTAL TAIL
STATION 3.26

22 AUG 63

CONDITION F-13

SX -4950.	SY -0.	MXX -0.	MYX -0.	T 39600.
	NO. IT. 2	QXP(N) 0.00001	QYP(N) -0.	
IX(NA) 3.10843E 01	IY(NA) 2.14645E 02	IXY(NA) -2.13219E-07	XBAR 3.40231E-01	YBAR -1.12572E-08
IX(NA)F 3.10843E 01	IY(NA)F 2.14645E 02	IXY(NA)F -2.13219E-07	XBARF 3.40231E-01	YBARF -1.12572E-08
AP(EFF) 1.22276E 00	AP(FULL) 1.22276E 00	A(TRUE) 3.78638E 00	2A(CELLS) 5.44888E 02	
	THETA X (RADIAN) 2.44026E-05	THETA Y (RADIAN) 0.	THETA T (RADIAN) 1.55197E-04	
	S.C.(X) -1.25789E 00	S.C.(X/C) 5.71215E-01	S.C.(Y) -0.	

NET WEB AND INTERNAL CELL SHEAR FLOWS

WEB	1	236.3224
CELL	1	236.3224
WEB	2	-383.0221
CELL	2	619.3445
WEB	3	-137.4832
CELL	3	33.9549

JOB NO. 1012

BOX BEAM ANALYSIS
 MODEL XV-5A
 HORIZONTAL TAIL
 STATION 3.26

22 AUG 63

CONDITION F-13

ITEM	WP(EFF)	F(P)	F(S)	OP(NET)
WEB 1				236.3224
1	1.1231	0.	0.	195.4432
2	3.3282	0.	0.	165.1693
3	4.3916	0.	0.	120.1427
4	4.3547	0.	0.	70.7770
5	3.2632	0.	0.	31.6181
WEB 2				414.6402 *
6	2.1953	0.	-0.	126.4700
7	3.2659	-0.	-0.	86.3961
8	4.3134	-0.	-0.	35.0124
9	3.2405	-0.	-0.	-1.7301
10	1.0929	-0.	-0.	-103.5283
WEB 3				-103.5283
11	1.0929	-0.	-0.	-1.7301
12	3.2405	-0.	-0.	35.0124
13	4.3134	-0.	-0.	86.3961
14	3.2659	-0.	-0.	126.4700
15	2.1953	0.	-0.	414.6402 *
WEB 2				31.6181
16	3.2632	0.	0.	70.7770
17	4.3547	0.	0.	120.1427
18	4.3916	0.	0.	165.1693
19	3.3282	0.	0.	195.4432
20	1.1231	0.	0.	236.3224
WEB 1				0.0000

* VALUE IS GREATER THAN MAXIMUM

JOB NO. 1012

BOX BEAM ANALYSIS
MODEL XV-5A
HORIZONTAL TAIL
STATION 3.26

22 AUG 63

CONDITION AF-6

SX 15550.	SY -0.	MXX -0.	MYX -0.	T 1700.
	NO. IT. 2	QXP(N) -0.00002	QYP(N) -0.	
IX(NA) 3.10843E 01	IY(NA) 2.14645E 02	IXY(NA) -2.13219E-07	XBAR 3.40231E-01	YBAR -1.12572E-08
IX(NA)F 3.10843E 01	IY(NA)F 2.14645E 02	IXY(NA)F -2.13219E-07	XBARF 3.40231E-01	YBARF -1.12572E-08
AP(EFF) 1.22276E 00	AP(FULL) 1.22276E 00	A(TRUE) 3.78638E 00	2A(CELLS) 5.44888E 02	
	THETA X (RADIAN) -7.66587E-05	THETA Y (RADIAN) 0.	THETA T (RADIAN) 6.66248E-06	
	S.C.(X) -1.25789E 00	S.C.(X/C) 5.71215E-01	S.C.(Y) -0.	

NET WEB AND INTERNAL CELL SHEAR FLOWS

WEB	1	-509.7087
CELL	1	-509.7087
WEB	2	1174.2493
CELL	2	-1683.9579
WEB	3	512.9666
CELL	3	73.9183

JOB NO. 1012

BOX BEAM ANALYSIS
 MODEL XV-5A
 HORIZONTAL TAIL
 STATION 3.26

22 AUG 63

CONDITION AF-6

ITEM	WP(EFF)	F(P)	F(S)	QP(NET)	
WEB 1				-509.7087	**
1	1.1231	0.	0.	-381.2903	**
2	3.3282	0.	0.	-286.1873	
3	4.3916	0.	0.	-144.7401	
4	4.3547	0.	0.	10.3380	
5	3.2632	0.	0.	133.3523	
WEB 2				-1040.8970	**
6	2.1953	0.	-0.	-135.6351	
7	3.2659	-0.	-0.	-9.7464	
8	4.3134	-0.	-0.	151.6712	
9	3.2405	-0.	-0.	267.0947	
10	1.0929	-0.	-0.	586.8849	*
WEB 3				586.8849	*
11	1.0929	-0.	-0.	267.0947	
12	3.2405	-0.	-0.	151.6712	
13	4.3134	-0.	-0.	-9.7464	
14	3.2659	-0.	-0.	-135.6351	
15	2.1953	0.	-0.	-1040.8970	**
WEB 2				133.3523	
16	3.2632	0.	0.	10.3379	
17	4.3547	0.	0.	-144.7401	
18	4.3916	0.	0.	-286.1873	
19	3.3282	0.	0.	-381.2903	**
20	1.1231	0.	0.	-509.7087	**
WEB 1				-0.0000	

* VALUE IS GREATER THAN MAXIMUM
 ** VALUE IS LESS THAN MINIMUM

JOB NO. 1012

BOX BEAM ANALYSIS
MODEL XV-5A
HORIZONTAL TAIL
STATION 3.26

22 AUG 63

CONDITION UNIT SH

SX 1000.	SY -0.	MXX -0.	MYX -0.	T -21700.
	NO. IT.	QXP(N)	QYP(N)	
	2	-0.00000	-0.	
IX(NA) 3.10843E 01	IY(NA) 2.14645E 02	IXY(NA) -2.13219E-07	XBAR 3.40231E-01	YBAR -1.12572E-08
IX(NA)F 3.10843E 01	IY(NA)F 2.14645E 02	IXY(NA)F -2.13219E-07	XBARF 3.40231E-01	YBARF -1.12572E-08
AP(EFF) 1.22276E 00	AP(FULL) 1.22276E 00	A(TRUE) 3.78638E 00	2A(CELLS) 5.44888E 02	
	THETA X (RADIAN) -4.92982E-06	THETA Y (RADIAN) 0.	THETA T (RADIAN) -8.50446E-05	
	S.C.(X) -1.25789E 00	S.C.(X/C) 5.71215E-01	S.C.(Y) -0.	

NET WEB AND INTERNAL CELL SHEAR FLOWS

WEB 1	-73.0209
CELL 1	-73.0209
WEB 2	80.5269
CELL 2	-153.5478
WEB 3	18.9661
CELL 3	-26.4790

CONDITION FOR UNIT 1000 * LOAD APPLIED
AT HINGE FITTING.

JOB NO. 1012

 BOX BEAM ANALYSIS
 MODEL XV-5A
 HORIZONTAL TAIL
 STATION 3.26

22 AUG 63

CONDITION UNIT SH

ITEM	WP(EFF)	F(P)	F(S)	QP(NET)
WEB 1				-73.0209
1	1.1231	0.	0.	-64.7625
2	3.3282	0.	0.	-58.6466
3	4.3916	0.	0.	-49.5503
4	4.3547	0.	0.	-39.5774
5	3.2632	0.	0.	-31.6665
WEB 2				-112.1934
6	2.1953	0.	-0.	-53.9772
7	3.2659	-0.	-0.	-45.8815
8	4.3134	-0.	-0.	-35.5009
9	3.2405	-0.	-0.	-28.0782
10	1.0929	-0.	-0.	-7.5129
WEB 3				-7.5129
11	1.0929	-0.	-0.	-28.0782
12	3.2405	-0.	-0.	-35.5009
13	4.3134	-0.	-0.	-45.8815
14	3.2659	-0.	-0.	-53.9772
15	2.1953	0.	-0.	-112.1934
WEB 2				-31.6665
16	3.2632	0.	0.	-39.5774
17	4.3547	0.	0.	-49.5503
18	4.3916	0.	0.	-58.6466
19	3.3282	0.	0.	-64.7625
20	1.1231	0.	0.	-73.0209
WEB 1				-0.0000

JOB NO. 1012

BOX BEAM ANALYSIS
MODEL XV-5A
HORIZONTAL TAIL
STATION 16.56

22 AUG 63

SECTION INPUT DATA

WIDTH TOL.	R(1TG)	R(PLATE)	W/T	G/1E6	
0.050	1.000	1.000	20.00	3.900	
C	X0/C	R(WEB)	2A(TE)	DS(TE)	
39.60	0.5470	1.000	0.	0.	
T(TE)	2A(LE)	DS(LE)	T(LE)		
0.	65.00	18.800	0.0200		
FP(MAX)	FP(MIN)	FS(MIN)	QP(MAX)		
45000.	-30000.	-40000.	320.		
WEB	XW(U)	YW(U)	XW(L)	YW(L)	TW
1	17.90	2.30	17.90	-2.30	0.0250
2	0.	3.46	0.	-3.46	0.0320
3	-13.00	2.63	-13.00	-2.63	0.0250

JOB NO. 1012

BOX BEAM ANALYSIS
 MODEL XV-5A
 HORIZONTAL TAIL
 STATION 16.56

22 AUG 63

SECTION INPUT DATA

ITEM	X(S)	Y(S)	A(S)	IXOS	IYOS	IXYOS	X(P)	Y(P)	T(P)	E/1E6
1	18.15	2.05	0.09	-0.	-0.	-0.	17.90	2.30	0.020	10.50
2	15.70	2.54	0.	-0.	-0.	-0.	15.70	2.54	0.020	0.
3	11.22	2.98	0.	-0.	-0.	-0.	11.22	2.98	0.020	0.
4	6.70	3.29	0.	-0.	-0.	-0.	6.70	3.29	0.020	0.
5	2.22	3.47	0.	-0.	-0.	-0.	2.22	3.47	0.020	0.
6	-0.25	3.21	0.28	-0.	-0.	-0.	0.	3.46	0.020	10.50
7	-2.18	3.43	0.	-0.	-0.	-0.	-2.18	3.43	0.020	0.
8	-6.58	3.23	0.	-0.	-0.	-0.	-6.58	3.23	0.020	0.
9	10.83	2.89	0.	-0.	-0.	-0.	-10.83	2.89	0.020	0.
10	-12.75	2.38	0.16	-0.	-0.	-0.	-13.00	2.63	0.020	10.50
11	-12.75	-2.38	0.16	-0.	-0.	-0.	-13.00	-2.63	0.020	10.50
12	10.83	-2.89	0.	-0.	-0.	-0.	-10.83	-2.89	0.020	0.
13	-6.58	-3.23	0.	-0.	-0.	-0.	-6.58	-3.23	0.020	0.
14	-2.18	-3.43	0.	-0.	-0.	-0.	-2.18	-3.43	0.020	0.
15	-0.25	-3.21	0.28	-0.	-0.	-0.	0.	-3.46	0.020	10.50
16	2.22	-3.47	0.	-0.	-0.	-0.	2.22	-3.47	0.020	0.
17	6.70	-3.29	0.	-0.	-0.	-0.	6.70	-3.29	0.020	0.
18	11.22	-2.98	0.	-0.	-0.	-0.	11.22	-2.98	0.020	0.
19	15.70	-2.54	0.	-0.	-0.	-0.	15.70	-2.54	0.020	0.
20	18.15	-2.05	0.09	-0.	-0.	-0.	17.90	-2.30	0.020	10.50

JOB NO. 1012

BOX BEAM ANALYSIS
MODEL XV-5A
HORIZONTAL TAIL
STATION 16.56

22 AUG 63

CONDITION F-12

SX -3980.	SY -0.	MXX -101000.	MYX -0.	T 15900.
	NO. IT. 3	QXP(N) 0.00001	QYP(N) -0.	
IX(NA) 1.26516E 01	IY(NA) 1.66809E 02	IXY(NA) 3.60062E 00	XBAR 2.24230E-01	YBAR 1.08724E 00
IX(NA)F 1.26513E 01	IY(NA)F 1.66805E 02	IXY(NA)F 3.60112E 00	XBARF 2.24142E-01	YBARF 1.08730E 00
AP(EFF) 6.44157E-01	AP(FULL) 1.23931E 00	A(TRUE) 3.14725E 00	2A(CELLS) 4.48400E 02	
	THETA X (RADIAN) 2.29099E-05	THETA Y (RADIAN) 0.	THETA T (RADIAN) 8.32638E-05	
	S.C.(X) -1.09921E 00	S.C.(X/C) 5.19242E-01	S.C.(Y) -0.	

NET WEB AND INTERNAL CELL SHEAR FLOWS

WEB 1	177.2504
CELL 1	177.2504
WEB 2	-345.4932
CELL 2	522.7436
WEB 3	-148.0167
CELL 3	-4.4975

JOB NO. 1012

 BOX BEAM ANALYSIS
 MODEL XV-5A
 HORIZONTAL TAIL
 STATION 16.56

22 AUG 63

CONDITION F-12

ITEM	WP(EFF)	F(P)	F(S)	QP(NET)
WEB 1				177.2504
1	1.1065	6676.05	4624.50	155.0706
2	3.3573	8985.43	8985.43	129.8029
3	4.5161	13296.75	13296.75	82.4553
4	4.5071	16570.75	16570.75	23.6191
5	3.3518	18793.55	18793.55	-25.4628
WEB 2				320.0304 *
6	2.2001	19098.21	17133.38	97.1977
7	3.2924	19235.28	19235.28	47.4412
8	4.3341	18391.76	18391.76	-15.4200
9	3.2245	16397.65	12641.43	-57.8506
10	1.0928	14685.44	12633.90	-152.5143
WEB 3				-152.5143
11	0.3318	-27566.86	-25602.02	20.1980
12	0.	-30031.69 **	-33787.90	20.1980
13	0.	-33499.85 **	-33499.85	20.1980
14	0.	-35869.44 **	-35869.44	20.1980
15	0.5768	-36488.47 **	-34436.93	418.1069 *
WEB 2				72.6136
16	0.	-36953.78 **	-36953.78	72.6136
17	0.	-36284.79 **	-36284.79	72.6136
18	0.	-34578.49 **	-34578.49	72.6136
19	0.	-31820.98 **	-31820.98	72.6136
20	0.3166	-30274.64 **	-28309.80	177.2504
WEB 1				0.0000

* VALUE IS GREATER THAN MAXIMUM

** VALUE IS LESS THAN MINIMUM

JOB NO. 1012

BOX BEAM ANALYSIS
MODEL XV-5A
HORIZONTAL TAIL
STATION 16.56

22 AUG 63

CONDITION F-13

SX -3980.	SY -0.	MXX -0.	MYX -0.	T 29000.
	NO. IT. 2	QXP(N) 0.00001	QYP(N) 0.	
IX(NA) 2.05239E 01	IY(NA) 2.15406E 02	IXY(NA) -2.19346E-07	XBAR 8.14388E-01	YBAR -2.22388E-09
IX(NA)F 2.05239E 01	IY(NA)F 2.15406E 02	IXY(NA)F -2.19346E-07	XBARF 8.14388E-01	YBARF -2.22388E-09
AP(EFF) 1.23931E 00	AP(FULL) 1.23931E 00	A(TRUE) 3.14725E 00	2A(CELLS) 4.48400E 02	
	THETA X (RADIAN) 5.78968E-06	THETA Y (RADIAN) -0.	THETA T (RADIAN) 1.51865E-04	
	S.C.(X) -2.77787E-01	S.C.(X/C) 5.39985E-01	S.C.(Y) 0.	

NET WEB AND INTERNAL CELL SHEAR FLOWS

WEB	1	225.1457
CELL	1	225.1457
WEB	2	-325.4054
CELL	2	550.5511
WEB	3	-123.6431
CELL	3	14.8414

JOB NO. 1012

BOX BEAM ANALYSIS
 MODEL XV-5A
 HORIZONTAL TAIL
 STATION 16.56

22 AUG 63

CONDITION F-13

ITEM	WP(EFF)	F(P)	F(S)	QP(NET)
WEB 1				225.1457
1	1.1065	0.	0.	180.4320
2	3.3573	0.	0.	146.6042
3	4.5161	0.	0.	94.3983
4	4.5071	0.	0.	36.8989
5	3.3518	0.	0.	-8.0235
WEB 2				317.3819
6	2.2001	0.	-0.	112.9392
7	3.2924	-0.	-0.	69.3890
8	4.3341	-0.	-0.	15.0583
9	3.2245	-0.	0.	-21.6889
10	1.0928	-0.	-0.	-108.8018
WEB 3				-108.8018
11	1.0928	-0.	-0.	-21.6889
12	3.2245	-0.	0.	15.0583
13	4.3341	-0.	-0.	69.3890
14	3.2924	-0.	-0.	112.9392
15	2.2001	0.	-0.	317.3819
WEB 2				-8.0235
16	3.3518	0.	0.	36.8989
17	4.5071	0.	0.	94.3983
18	4.5161	0.	0.	146.6042
19	3.3573	0.	0.	180.4320
20	1.1065	0.	0.	225.1457
WEB 1				0.0000

JOB NO. 1012

BOX BEAM ANALYSIS
MODEL XV-5A
HORIZONTAL TAIL
STATION 29.96

22 AUG 63

SECTION INPUT DATA

WIDTH TOL.	R(1STG)	R(PLATE)	W/T	G/1E6	
0.050	1.000	1.000	20.00	3.900	
C	X0/C	R(WEB)	2A(TE)	DS(TE)	
35.05	0.4810	1.000	-0.	-0.	
T(TE)	2A(LE)	DS(LE)	T(LE)		
-0.	18.00	8.600	0.0200		
FP(MAX)	FP(MIN)	FS(MIN)	QP(MAX)		
45000.	-30000.	-40000.	320.		
WEB	XW(U)	YW(U)	XW(L)	YW(L)	TW
1	18.18	2.12	18.18	-2.12	0.0250
2	0.	3.08	0.	-3.08	0.0320
3	-13.00	1.75	-13.00	-1.75	0.0250

JOB NO. 1012

BOX BEAM ANALYSIS
 MODEL XV-5A
 HORIZONTAL TAIL
 STATION 29.96

22 AUG 63

SECTION INPUT DATA

ITEM	X(S)	Y(S)	A(S)	IXOS	IYOS	IXYOS	X(P)	Y(P)	T(P)	E/1E6
1	18.43	1.87	0.09	-0.	-0.	-0.	18.18	2.12	0.020	10.50
2	15.85	2.38	0.	-0.	-0.	-0.	15.85	2.38	0.020	0.
3	11.30	2.77	0.	-0.	-0.	-0.	11.30	2.77	0.020	0.
4	6.78	3.04	0.	-0.	-0.	-0.	6.78	3.04	0.020	0.
5	2.30	3.12	0.	-0.	-0.	-0.	2.30	3.12	0.020	0.
6	-0.25	2.83	0.18	-0.	-0.	-0.	0.	3.08	0.020	10.50
7	-2.18	2.98	0.	-0.	-0.	-0.	-2.18	2.98	0.020	0.
8	-6.50	2.68	0.	-0.	-0.	-0.	-6.50	2.68	0.020	0.
9	-10.85	2.11	0.	-0.	-0.	-0.	-10.85	2.11	0.020	0.
10	-13.00	1.75	0.	-0.	-0.	-0.	-13.00	1.75	0.020	0.
11	-13.00	-1.75	0.	-0.	-0.	-0.	-13.00	-1.75	0.020	0.
12	-10.85	-2.11	0.	-0.	-0.	-0.	-10.85	-2.11	0.020	0.
13	-6.50	-2.68	0.	-0.	-0.	-0.	-6.50	-2.68	0.020	0.
14	-2.18	-2.98	0.	-0.	-0.	-0.	-2.18	-2.98	0.020	0.
15	-0.25	-2.83	0.18	-0.	-0.	-0.	0.	-3.08	0.020	10.50
16	2.30	-3.12	0.	-0.	-0.	-0.	2.30	-3.12	0.020	0.
17	6.78	-3.04	0.	-0.	-0.	-0.	6.78	-3.04	0.020	0.
18	11.30	-2.77	0.	-0.	-0.	-0.	11.30	-2.77	0.020	0.
19	15.85	-2.38	0.	-0.	-0.	-0.	15.85	-2.38	0.020	0.
20	18.43	-1.87	0.09	-0.	-0.	-0.	18.18	-2.12	0.020	10.50

JOB NO. 1012

BOX BEAM ANALYSIS
MODEL XV-5A
HORIZONTAL TAIL
STATION 29.96

22 AUG 63

CONDITION F-12

SX -2910.	SY -0.	MXX -55500.	MYX -0.	T 17600.
	NO. IT. 3	QXP(N) 0.00001	QYP(N) -0.	
IX(NA) 5.93590E 00	IY(NA) 9.00368E 01	IXY(NA) -2.18427E 00	XBAR 4.45439E 00	YBAR 1.40813E 00
IX(NA)F 5.93521E 00	IY(NA)F 9.00332E 01	IXY(NA)F -2.18389E 00	XBARF 4.45427E 00	YBARF 1.40828E 00
AP(EFF) 6.21130E-01	AP(FULL) 1.25200E 00	A(TRUE) 2.34202E 00	2A(CELLS) 3.55666E 02	
	THETA X (RADIANS) -6.45778E-05	THETA Y (RADIANS) 0.	THETA T (RADIANS) 1.29122E-04	
	S.C.(X) 3.02484E 00	S.C.(X/C) 5.67301E-01	S.C.(Y) -0.	

NET WEB AND INTERNAL CELL SHEAR FLOWS

WEB	1	193.0577
CELL	1	193.0577
WEB	2	-311.5655
CELL	2	504.6231
WEB	3	-35.4895
CELL	3	-1.0174

JOB NO. 1012

 BOX BEAM ANALYSIS
 MODEL XV-5A
 HORIZONTAL TAIL
 STATION 29.96

22 AUG 63

CONDITION F-12

ITEM	WP(EFF)	F(P)	F(S)	QP(NET)
WEB 1				193.0577
1	1.1722	9856.58	7555.00	145.8883
2	3.4556	11776.48	11776.48	101.8863
3	4.5474	14414.87	14414.87	33.1686
4	4.5044	15927.90	15927.90	-42.0594
5	3.3905	15657.40	15657.40	-98.0646
WEB 2				213.5009
6	2.2413	14753.61	12337.59	64.4829
7	3.2563	13311.16	13311.16	20.5101
8	4.3588	9491.91	9491.91	-22.8001
9	3.2836	3118.29	3118.29	-36.5069
10	0.	-770.44	-770.44	-36.5069
WEB 3				-36.5069
11	0.	-33793.61 **	-33793.61	-36.5069
12	0.	-36698.22 **	-36698.22	-36.5069
13	0.	-41080.72 **	-41080.72 **	-36.5069
14	0.	-42922.58 **	-42922.58 **	-36.5069
15	0.5291	-43367.18 **	-41065.60 **	368.0192 *
WEB 2				56.4537
16	0.	-43218.20 **	-43218.20 **	56.4537
17	0.	-41438.07 **	-41438.07 **	56.4537
18	0.	-37856.10 **	-37856.10	56.4537
19	0.	-33135.04 **	-33135.04	56.4537
20	0.3173	-30148.63 **	-27732.62	193.0577
WEB 1				0.0000

* VALUE IS GREATER THAN MAXIMUM

** VALUE IS LESS THAN MINIMUM

JOB NO. 1012

BOX BEAM ANALYSIS
MODEL XV-5A
HORIZONTAL TAIL
STATION 29.96

22 AUG 63

CONDITION F-13

SK -2910.	SY -0.	MXX -0.	MYX -0.	T 21300.
	NO. IT. 2	QXP(N) 0.00000	QYP(N) 0.	
IX(NA) 1.28762E 01	IY(NA) 1.46572E 02	IXY(NA) -5.45244E-08	XBAR 3.56366E 00	YBAR -7.85086E-09
IX(NA)F 1.28762E 01	IY(NA)F 1.46572E 02	IXY(NA)F -5.45244E-08	XBARF 3.56366E 00	YBARF -7.85086E-09
AP(EFF) 1.25200E 00	AP(FULL) 1.25200E 00	A(TRUE) 2.34202E 00	2A(CELLS) 3.55566E 02	
	THETA X (RADIANS) -4.90890E-05	THETA Y (RADIANS) -0.	THETA T (RADIANS) 1.56267E-04	
	S.C.(X) 2.29934E 00	S.C.(X/C) 5.46602E-01	S.C.(Y) 0.	

NET WEB AND INTERNAL CELL SHEAR FLOWS

WEB	1	202.5079
CELL	1	202.5079
WEB	2	-271.6844
CELL	2	474.1922
WEB	3	-58.9344
CELL	3	-1.6904

JOB NO. 1012

BOX BEAM ANALYSIS
 MODEL XV-5A
 HORIZONTAL TAIL
 STATION 29.96

22 AUG 63

CONDITION F-13

ITEM	WPI(EFF)	F(P)	F(S)	QP(NET)
WEB 1				202.5079
1	1.1722	0.	0.	154.1631
2	3.4556	0.	0.	116.1736
3	4.5474	0.	0.	59.2535
4	4.5044	0.	0.	-2.6305
5	3.3905	0.	0.	-50.3955
WEB 2				221.2889
6	2.2413	0.	-0.	77.0641
7	3.2563	-0.	-0.	33.6882
8	4.3588	-0.	-0.	-19.0842
9	3.2836	-0.	-0.	-51.5599
10	1.0900	-0.	-0.	-60.6248
WEB 3				-60.6248
11	1.0900	-0.	-0.	-51.5599
12	3.2836	-0.	-0.	-19.0842
13	4.3588	-0.	-0.	33.6882
14	3.2563	-0.	-0.	77.0641
15	2.2413	0.	-0.	221.2889
WEB 2				-50.3955
16	3.3905	0.	0.	-2.6305
17	4.5044	0.	0.	59.2535
18	4.5474	0.	0.	116.1736
19	3.4556	0.	0.	154.1631
20	1.1722	0.	0.	202.5079
WEB 1				0.0000

JOB NO. 1012

BOX BEAM ANALYSIS
MODEL XV-5A
HORIZONTAL TAIL
STATION 29.97

22 AUG 63

SECTION INPUT DATA

WIDTH TOL.	R(STG)	R(PLATE)	W/T	G/IE6	
0.050	1.000	1.000	20.00	3.900	
C	XO/C	R(WEB)	2A(TE)	DS(TE)	
35.05	0.4810	1.000	-0.	-0.	
T(TE)	2A(LE)	DS(LE)	T(LE)		
-0.	154.60	34.600	0.0200		
FP(MAX)	FP(MIN)	FS(MIN)	QP(MAX)		
45000.	-30000.	-40000.	320.		
WEB	XW(U)	YW(U)	XW(L)	YW(L)	TW
1	18.18	2.12	18.18	-2.12	0.0250
2	0.	3.08	0.	-3.08	0.0320

JOB NO. 1012

BOX BEAM ANALYSIS
MODEL XV-5A
HORIZONTAL TAIL
STATION 29.97

22 AUG 63

SECTION INPUT DATA

ITEM	X(S)	Y(S)	A(S)	IXOS	IYOS	IXYOS	X(P)	Y(P)	T(P)	E/1E6
1	18.43	1.87	0.09	-0.	-0.	-0.	18.18	2.12	0.020	10.50
2	15.85	2.38	0.	-0.	-0.	-0.	15.85	2.38	0.020	0.
3	11.30	2.77	0.	-0.	-0.	-0.	11.30	2.77	0.020	0.
4	6.78	3.04	0.	-0.	-0.	-0.	6.78	3.04	0.020	0.
5	2.30	3.12	0.	-0.	-0.	-0.	2.30	3.12	0.020	0.
6	-0.25	2.83	0.18	-0.	-0.	-0.	0.	3.08	0.020	10.50
7	-0.25	-2.83	0.18	-0.	-0.	-0.	0.	-3.08	0.020	10.50
8	2.30	-3.12	0.	-0.	-0.	-0.	2.30	-3.12	0.020	0.
9	6.78	-3.04	0.	-0.	-0.	-0.	6.78	-3.04	0.020	0.
10	11.30	-2.77	0.	-0.	-0.	-0.	11.30	-2.77	0.020	0.
11	15.85	-2.38	0.	-0.	-0.	-0.	15.85	-2.38	0.020	0.
12	18.43	-1.87	0.09	-0.	-0.	-0.	18.18	-2.12	0.020	10.50

JOB NO. 1012

BOX BEAM ANALYSIS
MODEL XV-5A
HORIZONTAL TAIL
STATION 29.97

22 AUG 63

CONDITION F-12

SX	SY	MXX	MYX	T
-2910.	-0.	-55500.	-0.	17600.
	NO. IT.	QXP(N)	QYP(N)	
	3	0.00000	-0.	
IX(NA)	IY(NA)	IXY(NA)	XBAR	YBAR
5.34288E 00	5.38623E 01	1.34265E 00	7.24244E 00	1.10579E 00
IX(NA)F	IY(NA)F	IXY(NA)F	XBARF	YBARF
5.34265E 00	5.38605E 01	1.34296E 00	7.24232E 00	1.10586E 00
AP(EFF)	AP(FULL)	A(TRUE)	2A(CELLS)	
3.75551E-01	7.28811E-01	2.25133E 00	3.58671E 02	
	THETA X (RADIAN)	THETA Y (RADIAN)	THETA T (RADIAN)	
	-8.32648E-05	0.	1.30059E-04	
	S.C.(X)	S.C.(X/C)	S.C.(Y)	
	3.87206E 00	5.91473E-01	-0.	

NET WEB AND INTERNAL CELL SHEAR FLOWS

WEB	1	201.1714
CELL	1	201.1714
WEB	2	-320.6837
CELL	2	-19.3745

JOB NO. 1012

BOX BEAM ANALYSIS
MODEL XV-5A
HORIZONTAL TAIL
STATION 29.97

22 AUG 63

CONDITION F-12

ITEM	WP(EFF)	F(P)	F(S)	QP(NET)
WEB 1				201.1714
1	1.1722	7750.50	5071.93	167.4859
2	3.4556	11075.75	11075.75	124.8491
3	4.5474	16338.63	16338.63	46.9837
4	4.5044	20339.25	20339.25	-49.0518
5	3.3905	22343.26	22343.26	-127.8680
6	1.1502	22524.61	19976.37	-340.0582 **
WEB 2				-340.0582 **
7	0.2692	-41869.67 **	-39191.10	34.8772
8	0.	-42887.31 **	-42887.31 **	34.8772
9	0.	-43218.74 **	-43218.74 **	34.8772
10	0.	-41574.41 **	-41574.41 **	34.8772
11	0.	-38683.46 **	-38683.46	34.8772
12	0.2881	-36572.84 **	-34024.60	201.1714
WEB 1				0.0000

** VALUE IS LESS THAN MINIMUM

JOB NO. 1012

BOX BEAM ANALYSIS
MODEL XV-5A
HORIZONTAL TAIL
STATION 29.97

22 AUG 63

CONDITION F-13

SX -2910.	SY -0.	MXX -0.	MYX -0.	T 21300.
	NO. IT. 2	QXP(N) 0.00000	QYP(N) -0.	
IX(NA) 9.30011E 00	IY(NA) 6.38779E 01	IXY(NA) -5.37032E-08	XBAR 7.76237E 00	YBAR -5.18962E-09
IX(NA)F 9.30011E 00	IY(NA)F 6.38779E 01	IXY(NA)F -5.37032E-08	XBARF 7.76237E 00	YBARF -5.18962E-09
AP(EFF) 7.28811E-01	AP(FULL) 7.28811E-01	A(TRUE) 2.25133E 00	2A(CELLS) 3.58671E 02	
	THETA X (RADIAN) -1.02510E-04	THETA Y (RADIAN) 0.	THETA T (RADIAN) 1.57400E-04	
	S.C.(X) 4.76700E 00	S.C.(X/C) 6.17006E-01	S.C.(Y) -0.	

NET WEB AND INTERNAL CELL SHEAR FLOWS

WEB	1	233.9686
CELL	1	233.9686
WEB	2	-282.5792
CELL	2	-12.3125

JOB NO. 1012

BOX BEAM ANALYSIS
MODEL XV-5A
HORIZONTAL TAIL
STATION 29.97

22 AUG 63

CONDITION F-13

ITEM	WP(EFF)	F(P)	F(S)	QP(NET)
WEB 1				233.9686
1	1.1722	0.	0.	167.0342
2	3.4556	0.	0.	114.4368
3	4.5474	0.	0.	35.6298
4	4.5044	0.	0.	-50.0500
5	3.3905	0.	0.	-116.1817
6	1.1502	0.	-0.	-294.8917
WEB 2				-294.8917
7	1.1502	0.	-0.	-116.1817
8	3.3905	0.	0.	-50.0500
9	4.5044	0.	0.	35.6298
10	4.5474	0.	0.	114.4368
11	3.4556	0.	0.	167.0342
12	1.1722	0.	0.	233.9686
WEB 1				0.0000

JOB NO. 1012

BOX BEAM ANALYSIS
MODEL XV-5A
HORIZONTAL TAIL
STATION 36.66

22 AUG 63

SECTION INPUT DATA

WIDTH TOL.	R(STG)	R(PLATE)	W/T	G/1E6	
0.050	1.000	1.000	20.00	3.900	
C	X0/C	R(WEB)	2A(TE)	DS(TE)	
32.70	0.4440	1.000	-0.	-0.	
T(TE)	2A(LE)	DS(LE)	T(LE)		
-0.	110.00	30.000	0.0200		
FP(MAX)	FP(MIN)	FS(MIN)	QP(MAX)		
45000.	-30000.	-36000.	320.		
WEB	XW(U)	YW(U)	XW(L)	YW(L)	TW
1	18.20	2.05	18.20	-2.05	0.0250
2	0.	2.85	0.	-2.85	0.0320

JOB NO. 1012

BOX BEAM ANALYSIS
MODEL XV-5A
HORIZONTAL TAIL
STATION 36.66

22 AUG 63

SECTION INPUT DATA

ITEM	X(S)	Y(S)	A(S)	IXOS	IYOS	IXYOS	X(P)	Y(P)	TIP)	E/1E6
1	18.45	1.80	0.09	-0.	-0.	-0.	18.20	2.05	0.020	10.50
2	15.88	2.29	0.	-0.	-0.	-0.	15.88	2.29	0.020	0.
3	11.32	2.67	0.	-0.	-0.	-0.	11.32	2.67	0.020	0.
4	6.82	2.90	0.	-0.	-0.	-0.	6.82	2.90	0.020	0.
5	2.28	2.92	0.	-0.	-0.	-0.	2.28	2.92	0.020	0.
6	-0.25	2.60	0.14	-0.	-0.	-0.	0.	2.85	0.020	10.50
7	-0.25	-2.60	0.14	-0.	-0.	-0.	0.	-2.85	0.020	10.50
8	2.28	-2.92	0.	-0.	-0.	-0.	2.28	-2.92	0.020	0.
9	6.82	-2.90	0.	-0.	-0.	-0.	6.82	-2.90	0.020	0.
10	11.32	-2.67	0.	-0.	-0.	-0.	11.32	-2.67	0.020	0.
11	15.88	-2.29	0.	-0.	-0.	-0.	15.88	-2.29	0.020	0.
12	18.45	-1.80	0.09	-0.	-0.	-0.	18.20	-2.05	0.020	10.50

JOB NO. 1012

BOX BEAM ANALYSIS
MODEL XV-5A
HORIZONTAL TAIL
STATION 36.66

22 AUG 63

CONDITION F-12

SX -2450.	SY -0.	MXX -38500.	MYX -0.	T 17300.
	NO. IT. 3	QXP(N) -0.00000	QYP(N) -0.	
IX(NA) 4.08682E 00	IY(NA) 4.94238E 01	IXY(NA) 6.80649E-01	XBAR 7.93562E 00	YBAR 1.14786E 00
IX(NA)F 4.08657E 00	IY(NA)F 4.94220E 01	IXY(NA)F 6.80898E-01	XBARF 7.93551E 00	YBARF 1.14795E 00
AP(EFF) 3.76658E-01	AP(FULL) 7.29407E-01	A(TRUE) 2.06631E 00	2A(CELLS) 3.04660E 02	
	THETA X (RADIAN) -1.13746E-04	THETA Y (RADIAN) 0.	THETA T (RADIAN) 1.64034E-04	
	S.C.(X) 4.89646E 00	S.C.(X/C) 5.93739E-01	S.C.(Y) -0.	

NET WEB AND INTERNAL CELL SHEAR FLOWS

WEB	1	202.7411
CELL	1	202.7411
WEB	2	-270.7655
CELL	2	-17.7710

JOB NO. 1012

BOX BEAM ANALYSIS
MODEL XV-5A
HORIZONTAL TAIL
STATION 36.66

22 AUG 63

CONDITION F-12

ITEM	WP(EFF)	F(P)	F(S)	QP(NET)
WEB 1				202.7411
1	1.1662	7182.55	4789.33	164.6120
2	3.4541	9750.64	9750.64	119.3380
3	4.5408	13932.13	13932.13	38.8979
4	4.5230	16689.41	16689.41	-57.1938
5	3.4106	17468.89	17468.89	-132.8720
6	1.1405	17104.52	14776.34	-288.5365
WEB 2				-288.5365
7	0.2875	-36719.37 **	-34326.15	28.5512
8	0.	-37676.99 **	-37676.99 **	28.5512
9	0.	-38078.76 **	-38078.76 **	28.5512
10	0.	-36492.35 **	-36492.35 **	28.5512
11	0.	-33497.33 **	-33497.33	28.5512
12	0.3102	-31532.88 **	-29204.71	202.7410
WEB 1				-0.0000

** VALUE IS LESS THAN MINIMUM

JOB NO. 1012

BOX BEAM ANALYSIS
MODEL XV-5A
HORIZONTAL TAIL
STATION 36.66

22 AUG 63

CONDITION F-13

SX -2450.	SY -0.	MXX -0.	MYX -0.	T 18600.
	NO. IT. 2	QXP(N) 0.00000	QYP(N) -0.	
IX(NA) 7.76741E 00	IY(NA) 5.88716E 01	IXY(NA) -2.48922E-08	XBAR 8.28272E 00	YBAR -3.54742E-09
IX(NA)F 7.76741E 00	IY(NA)F 5.88716E 01	IXY(NA)F -2.48922E-08	XBARF 8.28272E 00	YBARF -3.54742E-09
AP(EFF) 7.29407E-01	AP(FULL) 7.29407E-01	A(TRUE) 2.06631E 00	2A(CELLS) 3.04660E 02	
	THETA X (RADIAN) -1.29655E-04	THETA Y (RADIAN) 0.	THETA T (RADIAN) 1.76360E-04	
	S.C.(X) 5.58132E 00	S.C.(X/C) 6.14682E-01	S.C.(Y) -0.	

NET WEB AND INTERNAL CELL SHEAR FLOWS

WEB	1	218.8000
CELL	1	218.8000
WEB	2	-238.8471
CELL	2	-15.0055

JOB NO. 1012

BOX BEAM ANALYSIS
MODEL XV-5A
HORIZONTAL TAIL
STATION 36.66

22 AUG 63

CONDITION F-13

ITEM	WP(EFF)	F(P)	F(S)	OP(NET)
WEB 1				218.8000
1	1.1662	0.	0.	153.8823
2	3.4541	0.	0.	102.8867
3	4.5408	0.	0.	26.4369
4	4.5230	0.	0.	-56.3146
5	3.4106	0.	0.	-119.2281
6	1.1405	0.	-0.	-253.8526
WEB 2				-253.8526
7	1.1405	0.	-0.	-119.2281
8	3.4106	0.	0.	-56.3146
9	4.5230	0.	0.	26.4369
10	4.5408	0.	0.	102.8867
11	3.4541	0.	0.	153.8823
12	1.1662	0.	0.	218.8000
WEB 1				0.0000

JOB NO. 1012

BOX BEAM ANALYSIS
MODEL XV-5A
HORIZONTAL TAIL
STATION 36.66

22 AUG 63

CONDITION UNIT SH

SX 1000.	SY -0.	MXX -0.	MYX -0.	T -21700.
	NO. IT. 2	GXP(N) -0.00000	GYP(N) -0.	
IX(NA) 7.76741E 00	IY(NA) 5.88716E 01	IXY(NA) -2.48922E-08	XBAR 8.28272E 00	YBAR -3.54742E-09
IX(NA)F 7.76741E 00	IY(NA)F 5.88716E 01	IXY(NA)F -2.48922E-08	XBARF 8.28272E 00	YBARF -3.54742E-09
AP(EFF) 7.29407E-01	AP(FULL) 7.29407E-01	A(TRUE) 2.06631E 00	2A(CELLS) 3.04660E 02	
	THETA X (RADIAN) 5.29205E-05	THETA Y (RADIAN) 0.	THETA T (RADIAN) -2.05753E-04	
	S.C.(X) 5.58132E 00	S.C.(X/C) 6.14682E-01	S.C.(Y) -0.	

NET WEB AND INTERNAL CELL SHEAR FLOWS

WEB 1	-139.4500
CELL 1	-139.4500
WEB 2	86.8645
CELL 2	-33.3951

CONDITION FOR UNIT 1000# LOAD APPLIED
AT HINGE FITTING

JOB NO. 1012

BOX BEAM ANALYSIS
MODEL XV-5A
HORIZONTAL TAIL
STATION 36.66

22 AUG 63

CONDITION UNIT SH

ITEM	WP(EFF)	F(P)	F(S)	QP(NET)
WEB 1				-139.4500
1	1.1662	0.	0.	-112.9530
2	3.4541	0.	0.	-92.1385
3	4.5408	0.	0.	-60.9345
4	4.5230	0.	0.	-27.1583
5	3.4106	0.	0.	-1.4794
6	1.1405	0.	-0.	53.4694
WEB 2				53.4694
7	1.1405	0.	-0.	-1.4794
8	3.4106	0.	0.	-27.1583
9	4.5230	0.	0.	-60.9345
10	4.5408	0.	0.	-92.1385
11	3.4541	0.	0.	-112.9530
12	1.1662	0.	0.	-139.4500
WEB 1				-0.0000

JOB NO. 1012

BOX BEAM ANALYSIS
MODEL XV-5A
HORIZONTAL TAIL
STATION 50.60

22 AUG 63

SECTION INPUT DATA

WIDTH TOL.	R(1STG)	R(PLATE)	W/T	G/1E6	
0.050	1.000	1.000	20.00	3.900	
C	X0/C	R(WEB)	2A(TE)	DS(TE)	
28.30	0.3460	1.000	-0.	-0.	
T(TE)	2A(LE)	DS(LE)	T(LE)		
-0.	60.00	20.600	0.0157		
FP(MAX)	FP(MIN)	FS(MIN)	QP(MAX)		
45000.	-30000.	-36000.	250.		
WEB	XW(U)	YW(U)	XW(L)	YW(L)	TW
1	18.55	1.87	18.55	-1.87	0.0250
2	0.	2.30	0.	-2.30	0.0320

JOB NO. 1012

BOX BEAM ANALYSIS
MODEL XV-5A
HORIZONTAL TAIL
STATION 50.60

22 AUG 63

SECTION INPUT DATA

ITEM	X(S)	Y(S)	A(S)	IXOS	IYOS	IXYOS	X(P)	Y(P)	T(P)	E/1E6
1	18.80	1.62	0.09	-0.	-0.	-0.	18.55	1.87	0.016	10.50
2	16.26	2.08	0.	-0.	-0.	-0.	16.26	2.08	0.016	0.
3	11.66	2.44	0.	-0.	-0.	-0.	11.66	2.44	0.016	0.
4	6.96	2.59	0.	-0.	-0.	-0.	6.96	2.59	0.016	0.
5	2.34	2.47	0.	-0.	-0.	-0.	2.34	2.47	0.016	0.
6	-0.25	2.05	0.14	-0.	-0.	-0.	0.	2.30	0.016	10.50
7	-0.25	-2.05	0.14	-0.	-0.	-0.	0.	-2.30	0.016	10.50
8	2.34	-2.47	0.	-0.	-0.	-0.	2.34	-2.47	0.016	0.
9	6.96	-2.59	0.	-0.	-0.	-0.	6.96	-2.59	0.016	0.
10	11.66	-2.44	0.	-0.	-0.	-0.	11.66	-2.44	0.016	0.
11	16.26	-2.08	0.	-0.	-0.	-0.	16.26	-2.08	0.016	0.
12	18.80	-1.62	0.09	-0.	-0.	-0.	18.55	-1.87	0.016	10.50

JOB NO. 1012

BOX BEAM ANALYSIS
MODEL XV-5A
HORIZONTAL TAIL
STATION 50.60

22 AUG 63

CONDITION F-12

SX -1250.	SY -0.	MXX -16000.	MYX -0.	T 8700.
	NO. IT. 2	QXP(N) 0.00000	QYP(N) -0.	
IX(NA) 2.74586E 00	IY(NA) 4.89609E 01	IXY(NA) 6.68296E-01	XBAR 7.96980E 00	YBAR 8.96523E-01
IX(NA)F 2.74510E 00	IY(NA)F 4.89407E 01	IXY(NA)F 6.78861E-01	XBARF 7.96498E 00	YBARF 8.96961E-01
AP(EFF) 3.02023E-01	AP(FULL) 5.83531E-01	A(TRUE) 1.59965E 00	2A(CELLS) 2.36035E 02	
	THETA X (RADIANS) -1.31900E-04	THETA Y (RADIANS) 0.	THETA T (RADIANS) 1.48884E-04	
	S.C.(X) 6.16603E 00	S.C.(X/C) 5.63881E-01	S.C.(Y) -0.	

NET WEB AND INTERNAL CELL SHEAR FLOWS

WEB	1	120.0936
CELL	1	120.0936
WEB	2	-164.9429
CELL	2	-15.0417

JOB NO. 1012

BOX BEAM ANALYSIS
MODEL XV-5A
HORIZONTAL TAIL
STATION 50.60

22 AUG 63

CONDITION F-12

ITEM	WP(EFF)	F(P)	F(S)	QP(NET)
WEB 1				120.0936
1	1.1498	4832.21	3349.77	90.0122
2	3.4568	6246.20	6246.20	62.1468
3	4.6582	8724.88	8724.88	12.2456
4	4.6620	9983.47	9983.47	-44.8304
5	3.4839	9656.44	9656.44	-86.4889
6	1.1731	8852.01	7410.14	-179.9846
WEB 2				-179.9846
7	0.3218	-18051.63	-16569.20	7.1047
8	0.	-19235.73	-19235.73	7.1047
9	0.	-20312.37	-20312.37	7.1047
10	0.	-19816.38	-19816.38	7.1047
11	0.	-18084.06	-18084.06	7.1047
12	0.3315	-17041.63	-15599.75	120.0936
WEB 1				0.0000

JOB NO. 1012

BOX BEAM ANALYSIS
MODEL XV-5A
HORIZONTAL TAIL
STATION 70.16

22 AUG 63

SECTION INPUT DATA

WIDTH TOL.	R(STG)	R(PLATE)	W/T	G/IE6	
0.050	1.000	1.000	20.00	3.900	
C	X0/C	R(WEB)	2A(TE)	DS(TE)	
21.60	0.1220	1.000	-0.	-0.	
T(TE)	2A(LE)	DS(LE)	T(LE)		
-0.	9.00	6.000	0.0157		
FP(MAX)	FP(MIN)	FS(MIN)	QP(MAX)		
45000.	-30000.	-36000.	250.		
WEB	XW(U)	YW(U)	XW(L)	YW(L)	TW
1	18.94	1.62	18.94	-1.62	-0.
2	0.	1.24	0.	-1.24	-0.

JOB NO. 1012

BOX BEAM ANALYSIS
MODEL XV-5A
HORIZONTAL TAIL
STATION 70.16

22 AUG 63

SECTION INPUT DATA

ITEM	X(S)	Y(S)	A(S)	IXOS	IYOS	IXYOS	X(P)	Y(P)	T(P)	E/1E6
1	19.19	1.37	0.09	-0.	-0.	-0.	18.94	1.62	0.016	10.50
2	16.56	1.86	0.	-0.	-0.	-0.	16.56	1.86	0.016	0.
3	11.80	2.11	0.	-0.	-0.	-0.	11.80	2.11	0.016	0.
4	7.06	2.01	0.	-0.	-0.	-0.	7.06	2.01	0.016	0.
5	2.36	1.61	0.	-0.	-0.	-0.	2.36	1.61	0.016	0.
6	-0.25	0.99	0.14	-0.	-0.	-0.	0.	1.24	0.016	10.50
7	-0.25	-0.99	0.14	-0.	-0.	-0.	0.	-1.24	0.016	10.50
8	2.36	-1.61	0.	-0.	-0.	-0.	2.36	-1.61	0.016	0.
9	7.06	-2.01	0.	-0.	-0.	-0.	7.06	-2.01	0.016	0.
10	11.80	-2.11	0.	-0.	-0.	-0.	11.80	-2.11	0.016	0.
11	16.56	-1.86	0.	-0.	-0.	-0.	16.56	-1.86	0.016	0.
12	19.19	-1.37	0.09	-0.	-0.	-0.	18.94	-1.62	0.016	10.50

JOB NO. 1012

BOX BEAM ANALYSIS
MODEL XV-5A
HORIZONTAL TAIL
STATION 70.16

22 AUG 63

CONDITION # -12

SX -300.	SY -0.	MXX -1400.	MYX -0.	T 3200.
	NO. IT. 3	QXP(N) 0.00000	QYP(N) -0.	
IX(NA) 1.39682E 00	IY(NA) 5.26682E 01	IXY(NA) 8.33125E-01	XBAR 8.14362E 00	YBAR 6.66678E-01
IX(NA)F 1.39766E 00	IY(NA)F 5.26806E 01	IXY(NA)F 8.32720E-01	XBARF 8.14373E 00	YBARF 6.66193E-01
AP(EFF) 3.28008E-01	AP(FULL) 5.96773E-01	A(TRUE) 1.14297E 00	2A(CELLS) 1.49897E 02	
	THETA X (RADIAN) -1.01932E-04	THETA Y (RADIAN) 0.	THETA T (RADIAN) 9.75460E-05	
	S.C.(X) 1.11463E 01	S.C.(X/C) 6.38034E-01	S.C.(Y) -0.	

NET WEB AND INTERNAL CELL SHEAR FLOWS

WEB	1	48.0615
CELL	1	48.0615
WEB	2	-52.9229
CELL	2	-0.4029

JOB NO. 1012

BOX BEAM ANALYSIS
MODEL XV-5A
HORIZONTAL TAIL
STATION 70.16

22 AUG 63

CONDITION F-12

ITEM	WP(EFF)	F(P)	F(S)	QP(NET)
WEB 1				48.0615
1	1.1960	791.92	535.13	34.6163
2	3.5793	1072.65	1072.65	21.0908
3	4.7538	1401.53	1401.53	-1.3210
4	4.7290	1376.18	1376.18	-23.2193
5	3.5529	1046.82	1046.82	-36.3842
6	1.1944	710.40	461.60	-53.3258
WEB 2				-53.3258
7	1.0196	-1797.37	-1540.58	-0.9720
8	0.	-2209.24	-2209.24	-0.9720
9	0.	-2688.84	-2688.84	-0.9720
10	0.	-2865.73	-2865.73	-0.9720
11	0.	-2689.01	-2689.01	-0.9720
12	0.8672	-2484.36	-2235.56	48.0615
WEB 1				0.0000

JOB NO. 1012

BOX BEAM ANALYSIS
MODEL XV-5A
HORIZONTAL TAIL
STATION 70.16

22 AUG 63

CONDITION UNIT SH

SX 1000.	SY -0.	MXX -0.	MYX -0.	T -21700.
	NO. IT. 2	QXP(N) -0.00000	QYP(N) -0.	
IX(NA) 2.75749E 00	IY(NA) 5.96116E 01	IXY(NA) 6.75271E-09	XBAR 8.50010E 00	YBAR -5.77208E-09
IX(NA)F 2.75749E 00	IY(NA)F 5.96116E 01	IXY(NA)F 6.75271E-09	XBARF 8.50010E 00	YBARF -5.77208E-09
AP(EFF) 5.96773E-01	AP(FULL) 5.96773E-01	A(TRUE) 1.14297E 00	ZA(CELLS) 1.49897E 02	
	THETA X (RADIAN) 3.30179E-04	THETA Y (RADIAN) 0.	THETA T (RADIAN) -6.61484E-04	
	S.C.(X) 1.08315E 01	S.C.(X/C) 6.23461E-01	S.C.(Y) -0.	

NET WEB AND INTERNAL CELL SHEAR FLOWS

WEB	1	-223.8052
CELL	1	-223.8052
WEB	2	104.0667
CELL	2	-30.4287

CONDITION FOR UNIT 1000* LOAD APPLIED
AT HINGE FITTING

JOB NO. 1012

BOX BEAM ANALYSIS
MODEL XV-5A
HORIZONTAL TAIL
STATION 70.16

22 AUG 63

CONDITION UNIT SH

ITEM	WP(EFF)	F(P)	F(S)	QP(NET)
WEB 1				
1	1.1960	0.	0.	-223.8052
2	3.5793	0.	0.	-169.1408
3	4.7538	0.	0.	-130.4074
4	4.7290	0.	0.	-73.3005
5	3.5529	0.	0.	-19.1725
6	1.1944	0.	0.	14.6723
				73.6380
WEB 2				
7	1.1944	0.	-0.	73.6380
8	3.5529	0.	0.	14.6723
9	4.7290	0.	0.	-19.1725
10	4.7538	0.	0.	-73.3005
11	3.5793	0.	0.	-130.4074
12	1.1960	0.	0.	-169.1408
WEB 1				
1				-223.8052
				-0.0000

HORIZONTAL STABILIZER

SUMMARY OF SPAR CAP MARGINS OF SAFETY

CRITICAL COND: F-12

STA.	FRONT SPAR			CENTER SPAR			REAR SPAR		
	f_c	F_c	M.S.	f_c	F_c	M.S.	f_c	F_c	M.S.
3.26	28186	45600	+1.62	33342	47400	+1.42	27183	38100	+1.40
16.56	25602	38900	+1.52	34437	49100	+1.42	28310	38100	+1.34
29.96	0			41066	45600	+1.11	27733	38100	+1.37
36.66	-			34326	35600	+1.04	29205	38100	+1.30
50.6	-			16569	35600	+1.15	15600	38100	+1.44
70.16	-			1541	35600	HIGH	2236	38100	HIGH

HORIZONTAL STABILIZER

SPAR SHEAR ANALYSIS

FRONT SPAR INB'D B.L. 3.26

$$\text{MAX. } \tau = 513 \text{ \#/IN.} \quad \text{COND. AF-6}$$

.025 BASIC WEB WITH .020 DBL. (7075-T6)

$$A_s = .080 \text{ (TWO .032 ANGLES)}$$

$$\frac{A_s}{bt} = \frac{.080}{3.26 \times .045} = .54$$

$$\text{ALLOW. } \tau = 1.02 \times 1030 = 1050 \text{ \#/IN}$$

(REF. BOEING DESIGN MANUAL, P. 15.62209)

$$\text{M.S.} = \frac{1050}{513} - 1 = \underline{\underline{+1.05}}$$

FRONT SPAR OUTB'D B.L. 3.26

$$\text{MAX. } \tau = 163 \text{ \#/IN.} \quad \text{COND. F-12}$$

.025 7075-T6 WEB

$$\frac{A_s}{bt} = \frac{.080}{6.7 \times .025} = .48$$

$$\text{ALLOW. } \tau = .99 \times 520 = 514 \text{ \#/IN.}$$

$$\text{M.S.} = \frac{514}{163} - 1 = \underline{\underline{+2.15}}$$

HORIZONTAL STABILIZER

CENTER SPAR INBD B.L. 3.26

$$\text{MAX. } q = 1174 \text{ \#/in.} \quad \text{COND. AF-6}$$

.100 7075-T6 WEB

$$A_s = .23 \quad (\text{ATTACH. FTG. 143 T067})$$

$$\frac{A_s}{bt} = \frac{.23}{6.5 \times .1} = .35$$

$$\text{ALLOW. } q = .9 \times 2920 = 2625 \text{ \#/in.}$$

$$\text{M.S.} = \frac{2625}{1174} - 1 = + \underline{\underline{1.23}}$$

CENTER SPAR OUTBD B.L. 3.26

$$\text{MAX. } q = 401 \text{ \#/in.} \quad \text{COND. F-12 @ B.L. 3.26}$$

.032 7075-T6 WEB

$$A_s = .083 \quad (.75 \times .65 \times .032 \text{ ANGLE } \hat{E} \text{ FLANGED } .032 \text{ RIB})$$

$$\frac{A_s}{bt} = \frac{.083}{6.7 \times .032} = .39$$

$$\text{ALLOW. } q = .93 \times 700 = 650 \text{ \#/in.}$$

$$\text{M.S.} = \frac{650}{401} - 1 = + \underline{\underline{.62}}$$

HORIZONTAL STABILIZER

REAR SPAR INBD B.L. 3.26

$$\text{MAX. } q = 510 \text{ \#/in.} \quad \text{COND. AF-6}$$

.025 7075-T6 WEB

$$A_s = .078 \quad (2 \text{ .032 ANGLES, B.L. 3.26 RIB})$$

$$\frac{A_s}{b t} = \frac{.078}{6 \times .025} = .52$$

$$\text{ALLOW. } q = 1.01 \times 520 = 525$$

$$\text{M.S.} = \frac{525}{510} - 1 = + \underline{1.03}$$

REAR SPAR OUTBD B.L. 3.26

$$\text{MAX. } q = 236 \text{ \#/in} \quad \text{COND. F-13 @ BL 3.16}$$

.025 7075-T6 WEB

$$A_s = .038 \quad (.032 \text{ ANGLE})$$

$$\frac{A_s}{b t} = \frac{.038}{6.7 \times .025} = .23$$

$$\text{ALLOW. } q = .80 \times 520 = 416 \text{ \#/in.}$$

$$\text{M.S.} = \frac{416}{236} - 1 = + \underline{.76}$$

HORIZONTAL STABILIZER

HINGE RIBS

THE HINGE RIB ANALYSES ARE SUMMARIZED BY SHOWING ONLY "FREE-BODY" DIAGRAMS WITH APPLIED HINGE LOADS AND REACTING SHEAR FLOWS. REACTING SHEAR FLOWS ARE DETERMINED FROM THE BOX BEAM OUTPUT FOR THE UNIT SHEAR CONDITIONS LABELED COND. SH

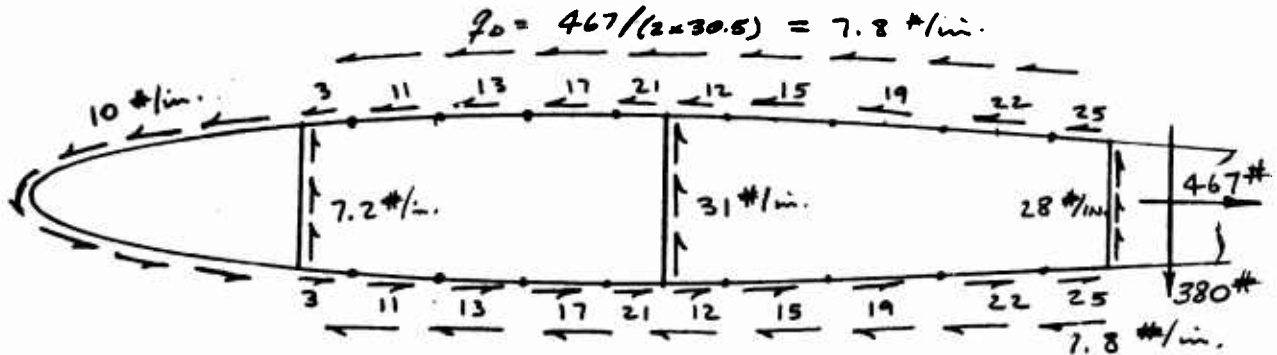

INBD HINGE RIB B.L. 3.26

COMPUTATION OF HG. LOAD :

$$\text{VERT. COMP.} = 71 \text{ \#} \quad \text{CHORDWISE COMP} = 1050 \text{ \#}$$

$$\text{ULT. HG. MOMENT} = 4110 \text{ \#}$$

REF. P. 92

$$\text{MOMENT ARM} = 4$$

$$\text{ACTUATING ROD LOAD} = \frac{4110}{4} = 1030 \text{ \#}$$

(REACTED EQUALLY AT THE INBD HINGES)

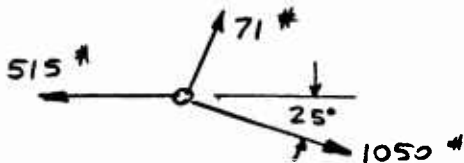

$$V = 71 \cos 25^\circ + 1050 \sin 25^\circ = 380 \text{ \#}$$

$$D = 515 - 1050 \cos 25^\circ - 71 \sin 25^\circ = 467 \text{ \#}$$

HORIZONTAL STABILIZER

HINGE RIBS

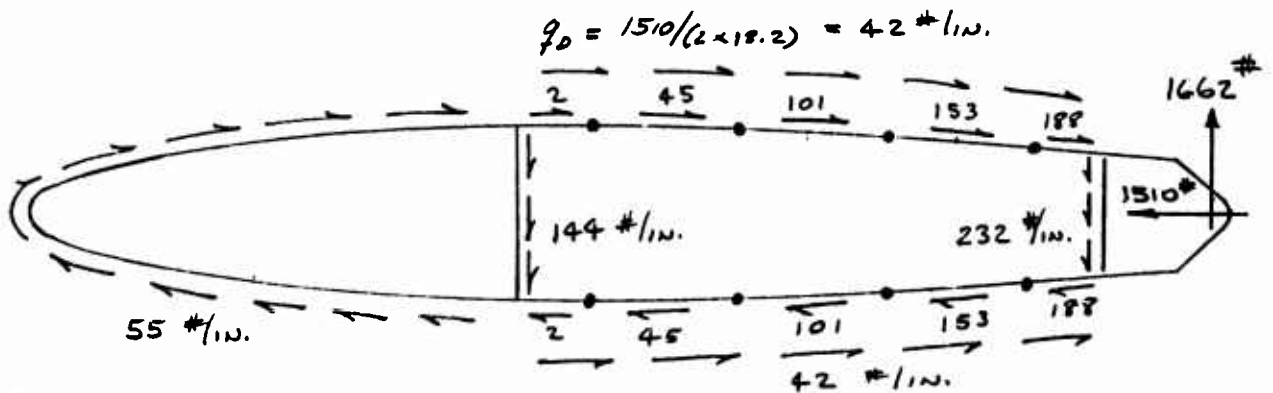

CENTER HINGE RIB B. L. 36.66

COMPUTATION OF HG. LOAD :

VERT. COMP. = 870 #

CHORDWISE COMP = 2070 #

REF P. 92

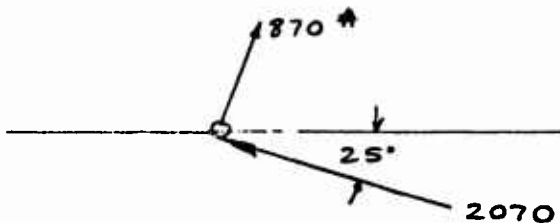

$$V = 870 \cos 25^\circ + 2070 \sin 25^\circ = 1662 \text{ #}$$

$$D = 2070 \cos 25^\circ - 870 \sin 25^\circ = 1510 \text{ #}$$

HORIZONTAL STABILIZER

HINGE RIBS

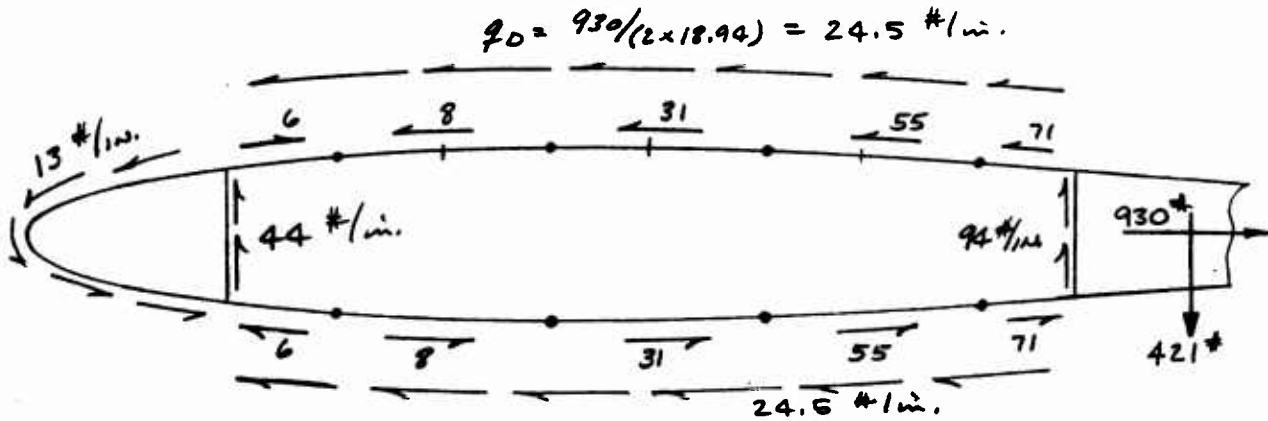

OUTBD HINGE RIB B.L. 70.16

COMPUTATION OF HG. LOAD :

$$\text{VERT. COMP.} = 11 \text{ #}$$

$$\text{CHORDWISE COMP.} = 1020 \text{ #}$$

(REF P. 82)

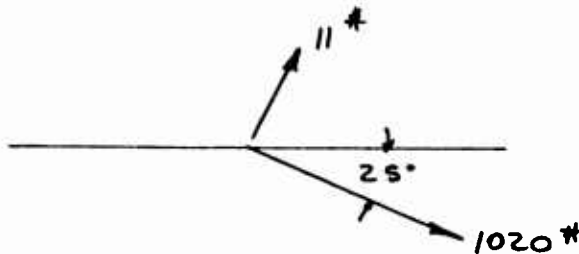

$$V = 11 \cos 25^\circ - 1020 \sin 25^\circ = 421 \text{ #}$$

$$D = -11 \sin 25^\circ - 1020 \cos 25^\circ = 930$$

HORIZONTAL STABILIZER

ACTUATOR SUPPORT FITTING (DWG. 143 T 065)

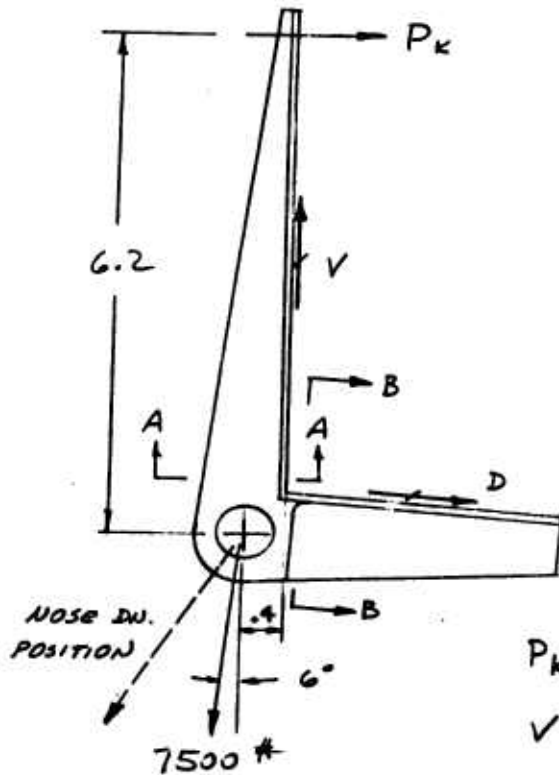

MATL : 7075 - T651
EXTRUDED BAR

$$F_{tu} (L) = 81000 \text{ psi}$$

$$F_{tu} (T) = 66000 \text{ psi}$$

$$F_{cy} (L) = 72000 \text{ psi}$$

$$F_{cy} (T) = 69000 \text{ psi}$$

ULT. LOAD = 7500 #
(REF. P. 7)

$$P_k = \frac{7500 \times .4}{6.2} = 484 \text{ #}$$

$$V = 7450 \text{ # (NOSE UP POSITION)}$$

$$D = 4600 \text{ # (NOSE DN. POSITION)}$$

LUG

$$a = .650 \quad D = .6875 \quad t = .332$$

USE MELLON - HOBLIT METHOD OF LUG ANALYSIS

$$W/D = 1.3 / .6875 = 1.89$$

$$a/D = .65 / .6875 = .945$$

$$D/t = .6875 / .332 = 2.07$$

HORIZONTAL STABILIZER

ACTUATOR SUPPORT FITTING

LUG

$$A_t = (1.3 - .6875) \cdot 332 = .2035$$

$$A_{br} = .6875 \times .332 = .228$$

$$P_{tu} = .97 \times .2035 \times 66000 = 13000 \text{ *}$$

$$P_{bru} = .78 \times .228 \times 66000 = 11700$$

$$M.S. = \frac{11700}{7500} - 1 = \underline{\underline{+1.56}}$$

SECTION A-A

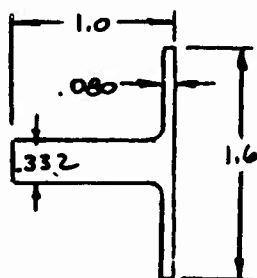

$$A = .433 \quad I = .04375 \quad \bar{x} = .393$$

$$M = 7500 \times .393 - 484 \times 6.2 = -50 \text{ " *}$$

$$f_t = \frac{7500}{.433} + \frac{50 \times .61}{.04375} = 18000 \text{ psi}$$

M.S. HIGH

SECTION B-B

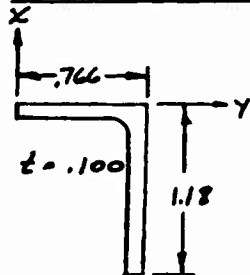

$$A = .1846 \quad \bar{x} = -.577 \quad \bar{y} = .395$$

$$I_x = .1493 \quad I_y = .031$$

$$M_x = 4600 (.189 - .166) = 106 \text{ " *}$$

$$M_y = 4600 \times .395 = 1816 \text{ " *}$$

$$f_t = \frac{4600}{.1846} + \frac{106 \times .189}{.031} + \frac{1816 \times .395}{.1493} = 30350 \text{ psi}$$

$$M.S. = \frac{66000}{30350} - 1 = \underline{\underline{+1.18}}$$

HORIZONTAL STABILIZER

HORIZ. STAB. PIVOT FITTING (DWG 143T067)

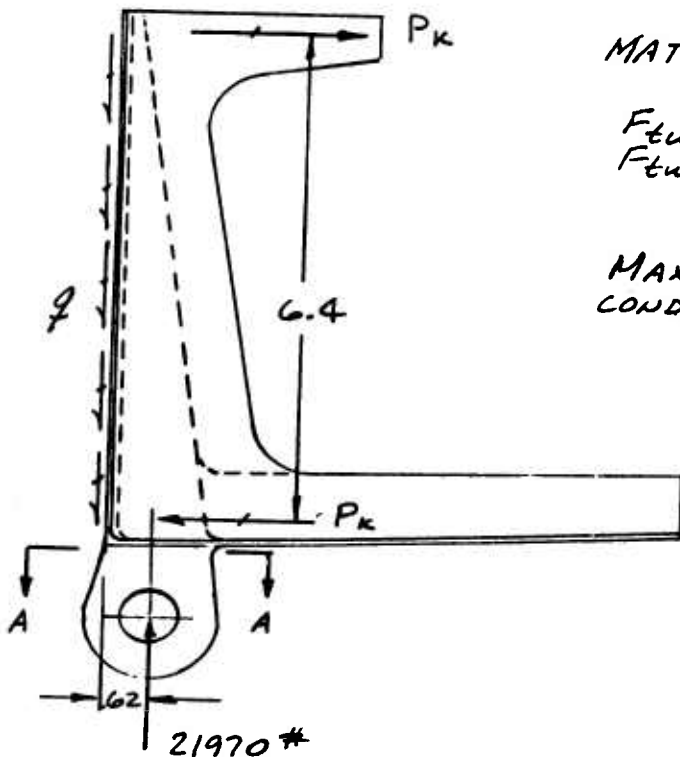

MATL: 7075-T651 ROLLED BAR

$F_{tu}(L) = 77000 \text{ psi}$

$F_{tu}(T) = 70000 \text{ psi}$

MAX. LOAD = 21970 #
COND. AF-6 REF. P. 7

$$P_k = \frac{21970 \times .62}{6.4} = 2120 \#$$

ATTACHMENT TO CENTER SPAR WEB:

9 BJS TO .032 OUTBD WEB

9 3/16 LOCKBOLTS TO .100 INBD WEB

$$\text{TOTAL ALLOWABLE} = 9(.9 \times 596 + 2620) = 28400 \#$$

$$M.S. = \frac{28400}{21970} - 1 = \underline{\underline{+.29}}$$

HORIZONTAL STABILIZER

HORIZ. STAB. PIVOT FITTING

ATTACHMENT TO RIB UPR. CAP :

4 5/32 RIVETS

ALLOW. SHEAR = $4 \times 596 = 2380$ *

$$M.S. = \frac{2380}{2120} - 1 = \underline{\underline{+.12}}$$

SECT. A-A :

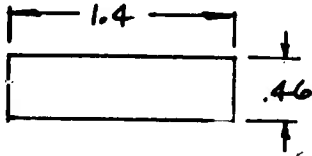

$$A = 1.4 \times .46 = .645$$

$$f_c = \frac{21970}{.645} = 34200 \text{ psi}$$

$$F_{cy} = 66000 \text{ psi}$$

$$M.S. = \frac{66000}{34200} - 1 = \underline{\underline{+.93}}$$

III. ELEVATOR

The elevator design loading is based on maximum torque input due to pilot effort. A conservative chordwise pressure distribution is assumed as shown on page 75. The torque about the hinge line resulting from the surface air load is equated to the torque applied by maximum pilot effort to find the magnitude of the air load. This load is greater than any load required to maneuver or balance the airplane within the design flight envelope.

Elevator hinge loads are found by solving the standard three-moment equations. The effect of hinge deflections induced by horizontal stabilizer deflection is included. Since the induced hinge deflections increase the center hinge load and reduce the inboard and outboard hinge loads, an additional arbitrary condition is considered to find conservative values for the outer hinge loads. This condition assumes zero moment at the center hinge.

The preliminary analysis is used for the final analysis. Since the preliminary analysis is based on a lower load than the final load, it is necessary to increase the results by the ratio of loads ($951/705 = 1.35$). The first analysis was also modified to include effect of the connecting torque tube being capable of taking the bending moment across the centerline.

The final stress analysis is brief since the complete structure was successfully proof tested and the design load is conservative.

Sambath
8/13/63

ELEVATOR

LOADING

USE FOLLOWING CHORDWISE PRESSURE DISTRIBUTION.

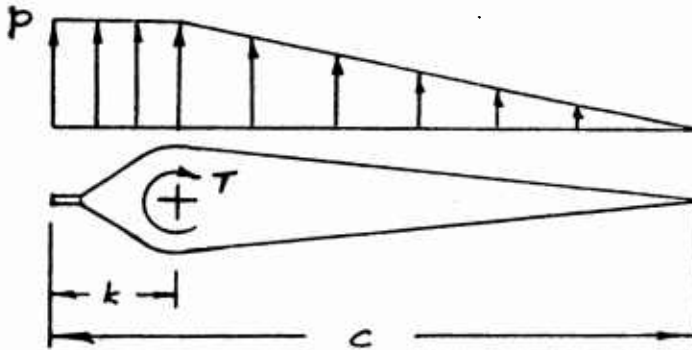

$$C_i = 19.89$$
$$C_o = 12.68$$

$$k = .194 c$$

$$\Delta T = \frac{p c^2}{6} (2k^2 + 2k - 1) dx = -.0895 p c^2 dx$$

$$T = \int_0^{5.65} -.0895 p c^2 dx \quad C = 12.68 + .1098 x$$

$$T = 1584 p$$

ULT. PIVOT EFFORT TORQUE PER SIDE = 2055 " *

$$2055 = 1584 p$$

$$p = 1.297 \text{ psi (ULT.)}$$

$$W = \frac{p c}{2} (k + 1) = .775 c$$

$$W_i = .775 \times 19.89 = 15.4 \text{ \#/in.}$$

$$W_o = .775 \times 12.68 = 9.8 \text{ \#/in.}$$

$$\text{TOTAL LOAD} = \left(\frac{15.4 + 9.8}{2} \right) 65.65 = 830 \text{ \# ULT.} *$$

* A TOTAL LOAD OF 951 # WAS USED FOR ORIGINAL DESIGN AND PROOF TEST. THEREFORE 951 # LOAD WILL BE USED FOR FINAL ANALYSIS.

Dambert
11/7/62

ELEVATOR HINGE LOADS

NOTE: INCREASE ALL LOADS BY 35%

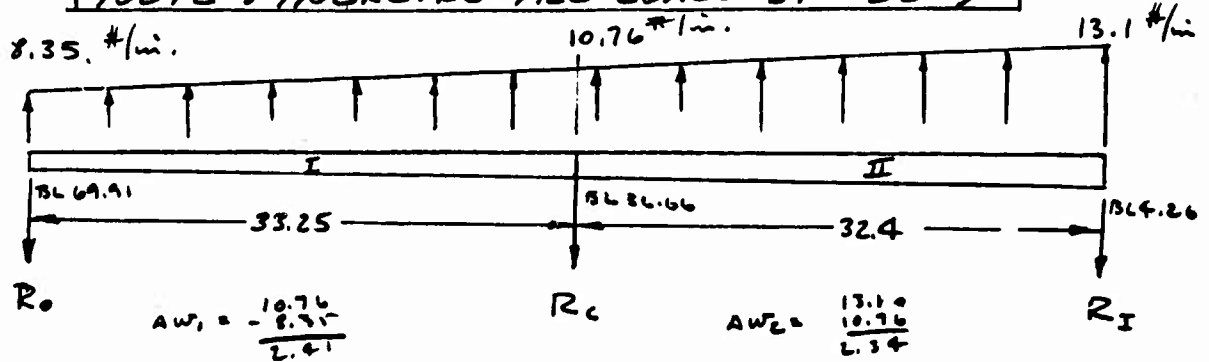

Av. I_I = .28
Av. I_{II} = .47 } REF. ELEVATOR DEFLECTION 10/23/62

ABOVE LOAD BASED ON ASSUMED PRESSURE DISTRIBUTION CALCULATED ON 11/7/62

INCLUDE SPT. DEFLECTIONS BASED ON MAX. STAB. DEFLECTION:

$\delta_o = 1.44$ $\delta_c = .38$ $\delta_I = 0$

USE THREE-MOMENT EQ. TO SOLVE FOR M_c

$$\frac{2 M_c L_1}{I_1} + \frac{2 M_c L_2}{I_2} = \frac{w_1 L_1^3}{4 I_1} + \frac{2 \Delta w_1 L_1^3}{15 I_1} + \frac{w_2 L_2^3}{4 I_2} + \frac{7 \Delta w_2 L_2^3}{60 I_2} + \frac{6 E}{L_1} (\delta_o - \delta_c) + \frac{6 E}{L_2} (\delta_I - \delta_c)$$

$$\left(\frac{2 \times 33.25}{.28} + \frac{2 \times 32.4}{.47} \right) M_c = \left(\frac{8.35}{4} + \frac{2 \times 2.41}{15} \right) \frac{33.25^3}{.28} + \left(\frac{10.76}{4} + \frac{7 \times 2.34}{60} \right) \frac{32.4^3}{.47} + \frac{6 \times 10.5 \times 10^6}{33.25} (1.44 - .38) + \frac{6 \times 10.5 \times 10^6}{32.4} (0 - .38)$$

Lambert
11/7/62

ELEVATOR HINGE LOAD

$$376 M_c = 2.457 \times 131200 + 2.963 \times 72400 + (1.893 \times 1.06 + 1.943 \times -.38) 10^6$$

$$376 M_c = 316500 + 214500 + 1266000$$

$$M_c = 4780 \text{ " #}$$

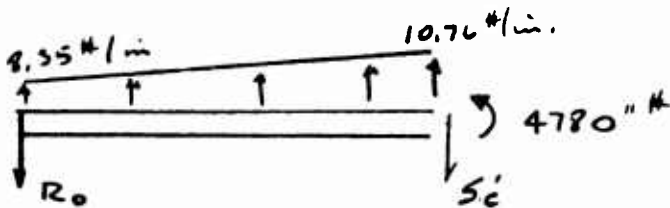

$$33.25 R_0 = 8.35 \times \frac{33.25^2}{2} + 2.41 \times \frac{33.25^2}{6} - 4780$$

$$R_0 = 8 \text{ #}$$

$$S_c' = \left(\frac{8.35 + 10.76}{2} \right) 33.25 - 8 = 310 \text{ #}$$

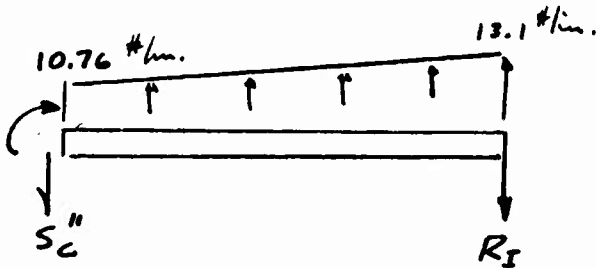

$$32.4 S_c'' = 10.76 \times \frac{32.4^2}{2} + 2.34 \times \frac{32.4^2}{6} + 4780$$

$$S_c'' = 334 \text{ #}$$

$$R_I = \left(\frac{10.76 + 13.1}{2} \right) 32.4 - 334 = 53 \text{ #}$$

$$R_c = 310 + 334 = 644 \text{ #}$$

Lambert
1/12/63

ELEVATOR HG. LOAD

WORK DONE ON 11/7/62 IS REVISED TO INCLUDE EFFECT OF CONTINUOUS TORQUE TUBE ACROSS ξ

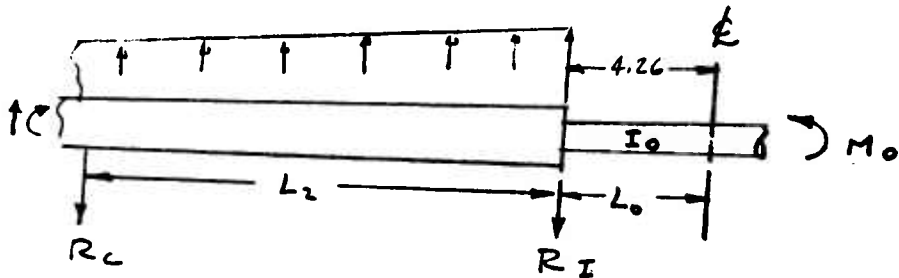

1.56 x .08 TUBE (STEEL)

$$I = \frac{\pi}{4} (.78^4 - .70^4) = .102$$

$$I \text{ (EQUIV FOR AL. AL. E)} = \frac{29}{10.5} \times .102 = .282$$

$$\frac{2M_c L_1}{I_1} + \frac{2M_c L_2}{I_2} + \frac{M_I L_2}{I_2} = f(w) + f(\delta)$$

$$376 M_c + 69 M_I = 1797000 \text{ --- (1)}$$

$$\frac{M_c L_2}{I_2} + \frac{2M_I L_2}{I_2} + \frac{2M_I L_0}{I_0} + \frac{M_0 L_0}{I_0} = \frac{10.76 \times 32.4^3}{4 I_2}$$

$$+ \frac{2 \times 2.34 \times 32.4^3}{15 I_2} + \frac{6E}{I_2} (\delta_c - \delta_I) + \frac{6E}{I_0} (\delta_0 - \delta_I)$$

$$M_c \times \frac{32.4}{.47} + 2M_I \left(\frac{32.4}{.47} + \frac{4.26}{.282} \right) + M_0 \times \frac{4.26}{.282} = 194200 + 22600$$

$$+ \frac{6 \times 10.5 \times 10^6}{47} (.38 - 0)$$

Fambert
1/12/63

ELEVATOR HG. LOAD

$$M_0 = M_I \quad (\text{NO SHEAR ACROSS } \frac{L}{2})$$

$$69 M_c + 183.3 M_I = 726800 \quad \text{--- --- --- (2)}$$

$$\begin{array}{r} 376 M_c + 69 M_I = 1797000 \\ - 376 M_c - 1000 M_I = -3960000 \\ \hline - 931 M_I = -2163000 \end{array}$$

$$M_I = 2320 \text{ " \#}$$

$$376 M_c = 1797000 - 69 \times 2320$$

$$M_c = 4350 \text{ " \#} \quad (\text{VS. } 4780 \text{ " \# WITHOUT CENTER TUBE CONTINUITY})$$

$$\text{ULT. HG. MOMENT} = 2055 \text{ " \#}$$

$$\text{ROD LOAD} = \frac{2055}{4} = 514 \text{ \#}$$

$$\text{CHORDWISE B.M.} = \frac{514}{2} \times 4.26 = 1090 \text{ " \#}$$

$$\text{RES. B.M.} = (2320^2 + 1090^2)^{1/2} = 2570 \text{ " \#}$$

$$f_b = \frac{2570 \times .78}{.102} = 19700 \text{ psi}$$

M.S. HIGH

Sambut
11/7/62

ELEVATOR HG. LOADS

CHORDWISE LOADS

$$\text{CHORDWISE DEFLECTIONS} = \delta \sin 25^\circ$$

$$\delta_c' = .38 \times .422 = .16$$

$$\delta_o' = 1.44 \times .422 = .609$$

MOMENT OF INERTIA:

ASSUME .02 HAG. SKIN - FULLY EFFECTIVE

$$C_I = 14.5$$

$$I_I = \frac{2 \times .02 \times 14.5^3}{12} = 10.2$$

$$C_{II} = 18.1$$

$$I_{II} = \frac{2 \times .02 \times 18.1^3}{12} = 19.7$$

$$\frac{2 M_c L_1}{I_1} + \frac{2 M_c L_2}{I_2} = \frac{6E}{L_1} (\delta_o - \delta_c) + \frac{6E}{L_2} (\delta_I - \delta_c)$$

$$\left(\frac{2 \times 33.25}{10.2} + \frac{2 \times 32.4}{19.7} \right) M_c = \frac{6 \times 6.5 \times 10^6}{33.25} (.609 - .16) + \frac{6 \times 6.5 \times 10^6}{32.4} (0 - .16)$$

$$9.82 M_c = 333000$$

$$M_c = 34000 \text{ " \#}$$

$$R_o = \frac{34000}{33.25} = 1020 \text{ \#}$$

$$R_I = \frac{34000}{32.4} = 1050 \text{ \#}$$

$$R_c = 1020 + 1050$$

$$= 2070 \text{ \#}$$

Sambut
11/8/62

ELEVATOR HG. LOADS

INBD & OUTBD HG. LOADS

CONSIDER SURFACE PINNED @ CENTER HINGE
TO DETERMINE MAX. LOADS

SEE LOADS & GEOMETRY ON P. 2

$$33.25 R_o = 8.35 \times \frac{33.25^2}{2} + 2.41 \times \frac{33.25^2}{6}$$

$$R_o = 5054 / 33.25 = 152 \#$$

$$S'_c = \left(\frac{8.35 + 10.76}{2} \right) 33.25 - 152 = 166 \#$$

$$32.4 S_c'' = 10.76 \times \frac{32.4^2}{2} + 2.34 \times \frac{32.4^2}{6}$$

$$S_c'' = 6050 / 32.4 = 187 \#$$

$$R_i = \left(\frac{10.76 + 13.1}{2} \right) 32.4 - 187 = 200 \#$$

$$R_c = 166 + 187 = 353 \#$$

NOTE: INCREASE LOADS BY 35%.

Sambut
8/16/63

ELEVATOR

SUMMARY OF HINGE LOADS

	<u>OUTB'D HG.</u>	<u>CENTER HG.</u>	<u>INB'D HG.</u>
	VERTICAL LOADS		
CONTINUOUS BEAM OVER CENTER SUPPORT	± 11 #	± 870 #	± 71 #
	CHORDWISE LOADS		
	+ 1020 #	- 2070 #	+ 1050 #
	VERTICAL LOADS		
ZERO MOMENT @ CENTER SUPPORT	± 205 #	± 477 #	± 270 #

Lambert
1/14/65

ELEVATOR

ULT. SHEAR & B.M.

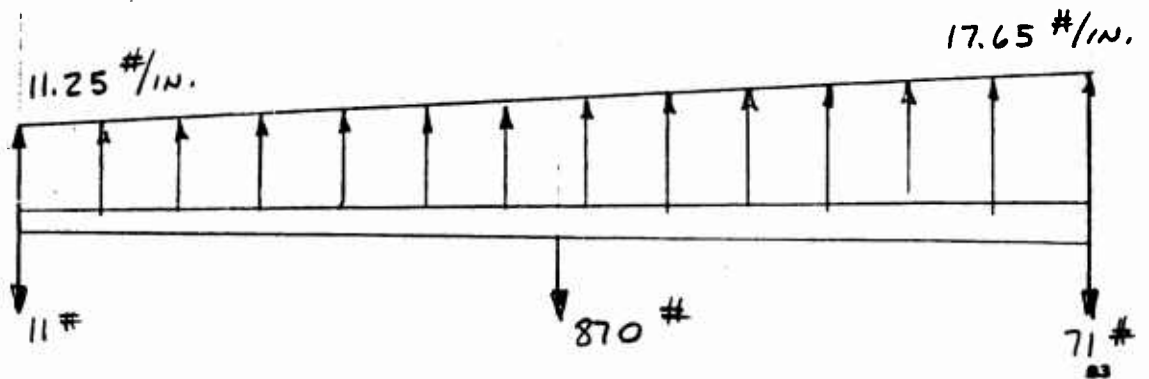
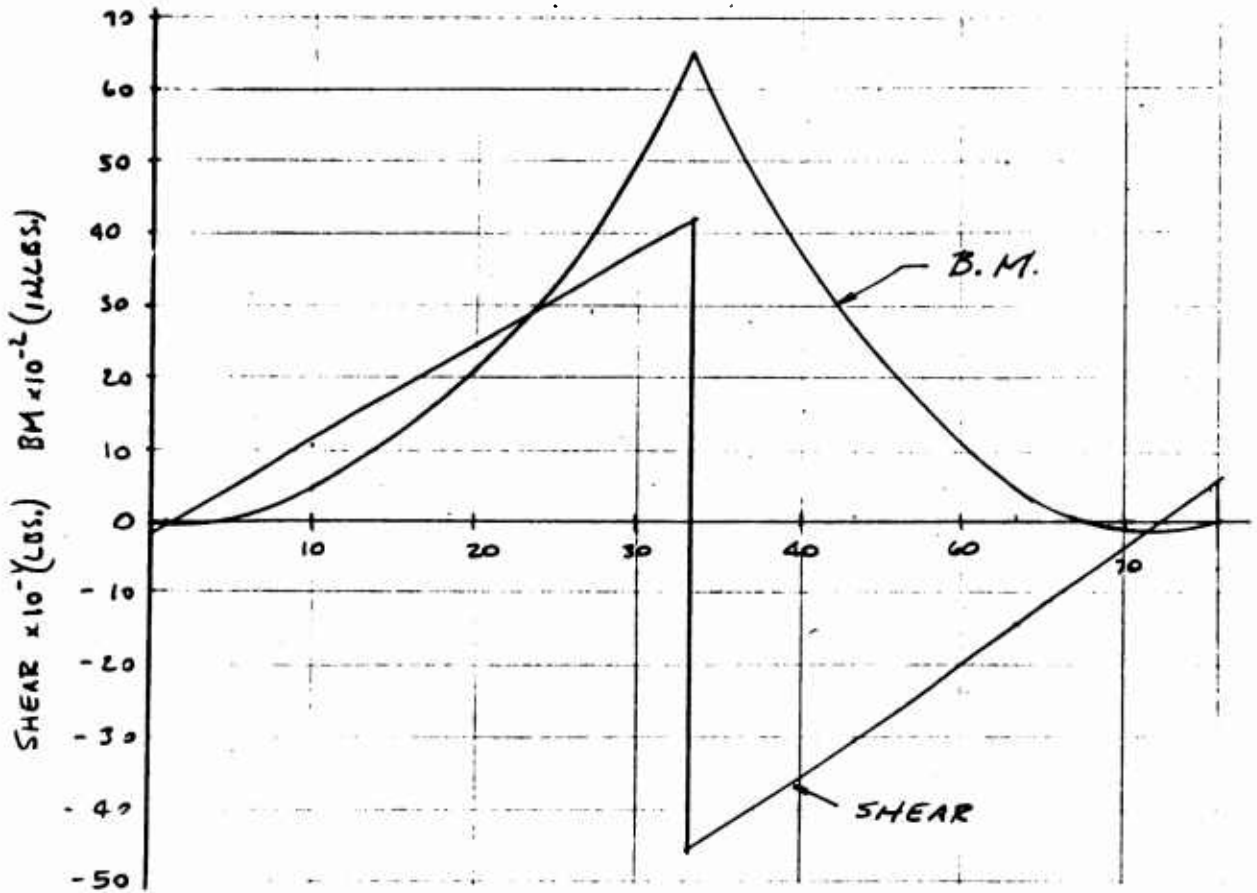

ELEVATOR

BENDING CHECK AT CENTER HINGE

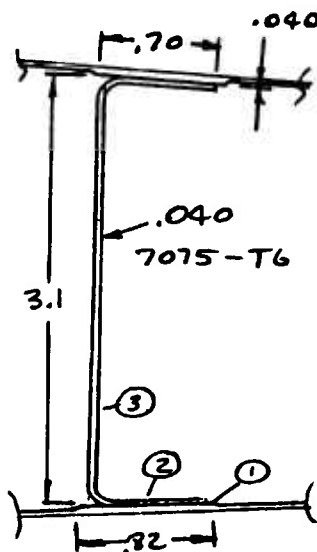

$$\text{EFF. SKIN } A = 2 \times .04 \times .82 \times \frac{6.5}{10.5} = .0405$$

ELE	A	R	AE ²	I _o
1	.0405	1.57	.1100	0
2	.0528	1.53	.1238	0
3	.121	0	0	.0916
Σ			.2238	.0916

$$I = .3154$$

$$\text{MAX. B. M.} = 6450 \text{ " \#}$$

$$f_{bc} = \frac{6450 \times 1.53}{.3154} = 31300 \text{ psi}$$

FIND ALLOWABLE CRIPPLING STRESS BY METHOD GIVEN IN RYAN STRUCTURES MANUAL, P. 5.9

$$\frac{b'}{t} = .68 / .04 = 17$$

$$\frac{F_{cc}}{\sqrt{F_{cy} E}} = .039$$

$$F_{cc} = .039 \sqrt{68000 \times 10.5 \times 10^6} = 33000 \text{ psi}$$

$$\text{M.I.S.} = \frac{33000}{31300} - 1 = \underline{\underline{+.05}}$$

IV. VERTICAL STABILIZER

Description of Structure

The vertical stabilizer is a three-spar conventional semi-monocoque structure. The skin is stiffened by closely spaced ribs. The horizontal stabilizer is attached to the tip of the vertical stabilizer by means of symmetrically placed pivot fittings at the center spar and the actuator link attached to the centerline of the front spar. Attachment to the fuselage is provided by frames or bulkheads which are designed as integral parts of the spars. The skins are attached to the fuselage skins by drag angles which also function as fuselage longerons.

Critical Conditions

Two critical conditions are considered as follows:

LG-4 - max. shear and bending moment
(asym. flight - lateral gust, $V(G) = 40$ FPS, aft C.G., $n_z = 1.0$,
 $q = 595$ PSF, mach = 0.638)

AF-10 - max. torsion
(rudder kick, aft C.G. $n_z = 1.0$, $q = 595$ PSF, mach = 0.638)

Loads curves (shear, B.M. and torque) for these conditions are shown on pages 88, 89 and 90.

Method of Analysis

Bending stresses and shear flows are computed by a digital computer using ordinary engineering theory. The program used is described in Ryan Report 62B118. "Description of Box Beam Program for IBM Job No. 1012", 18 Nov. 1962. No tension skin is effective at the root section (V.S. STA. 13.4) since the fin/fuselage skin joint cannot transmit skin bending stresses.

The computed bending stresses (based on Mc/I) near the fuselage attachment are not accurate, since the sweep effect has been neglected. These rear spar stresses are low (on the order of 30%), but it is believed that a more exact analysis is not necessary, since the root section margins of safety are ample. These high margins resulted from a substantial load reduction after the design was completed.

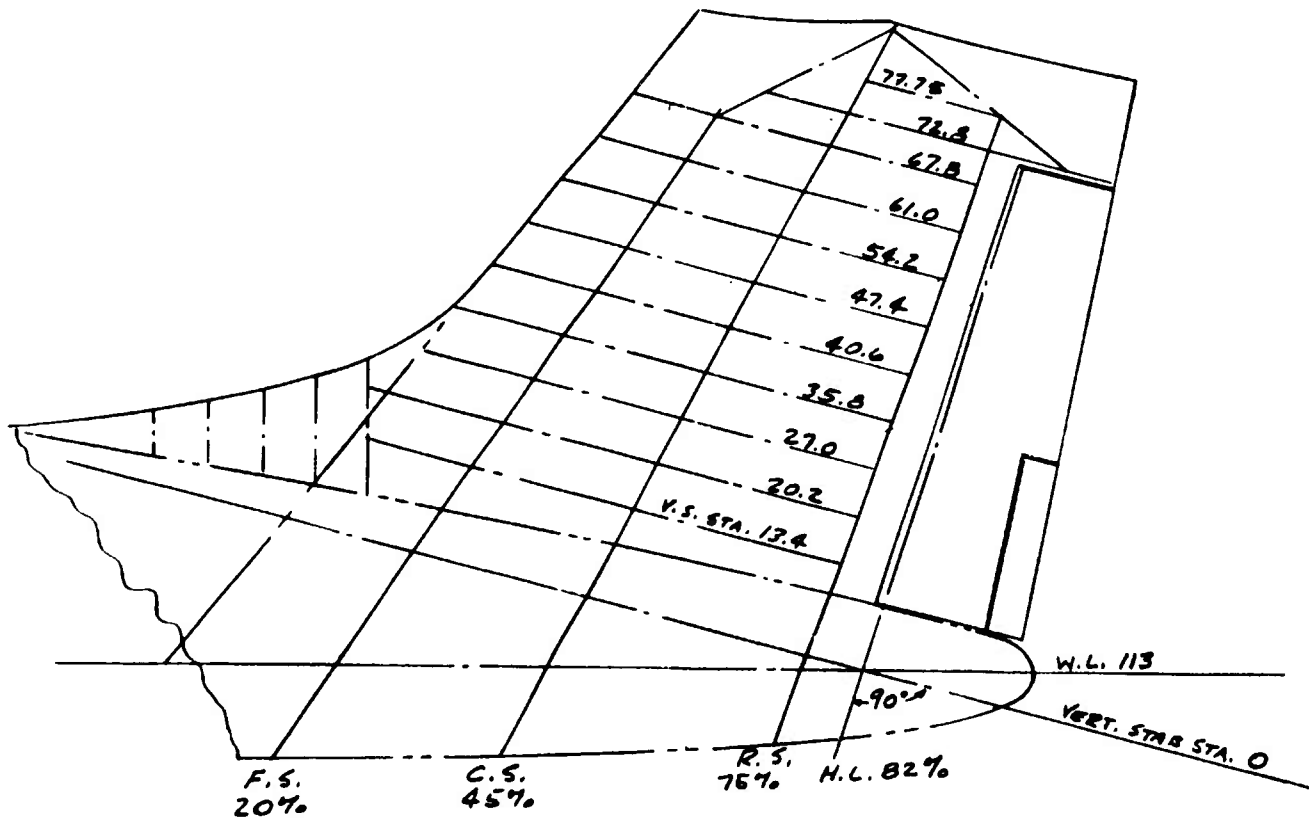

VERTICAL STABILIZER
 (REF. DWG 143T004)

VERTICAL STABILIZER ULT. SHEAR

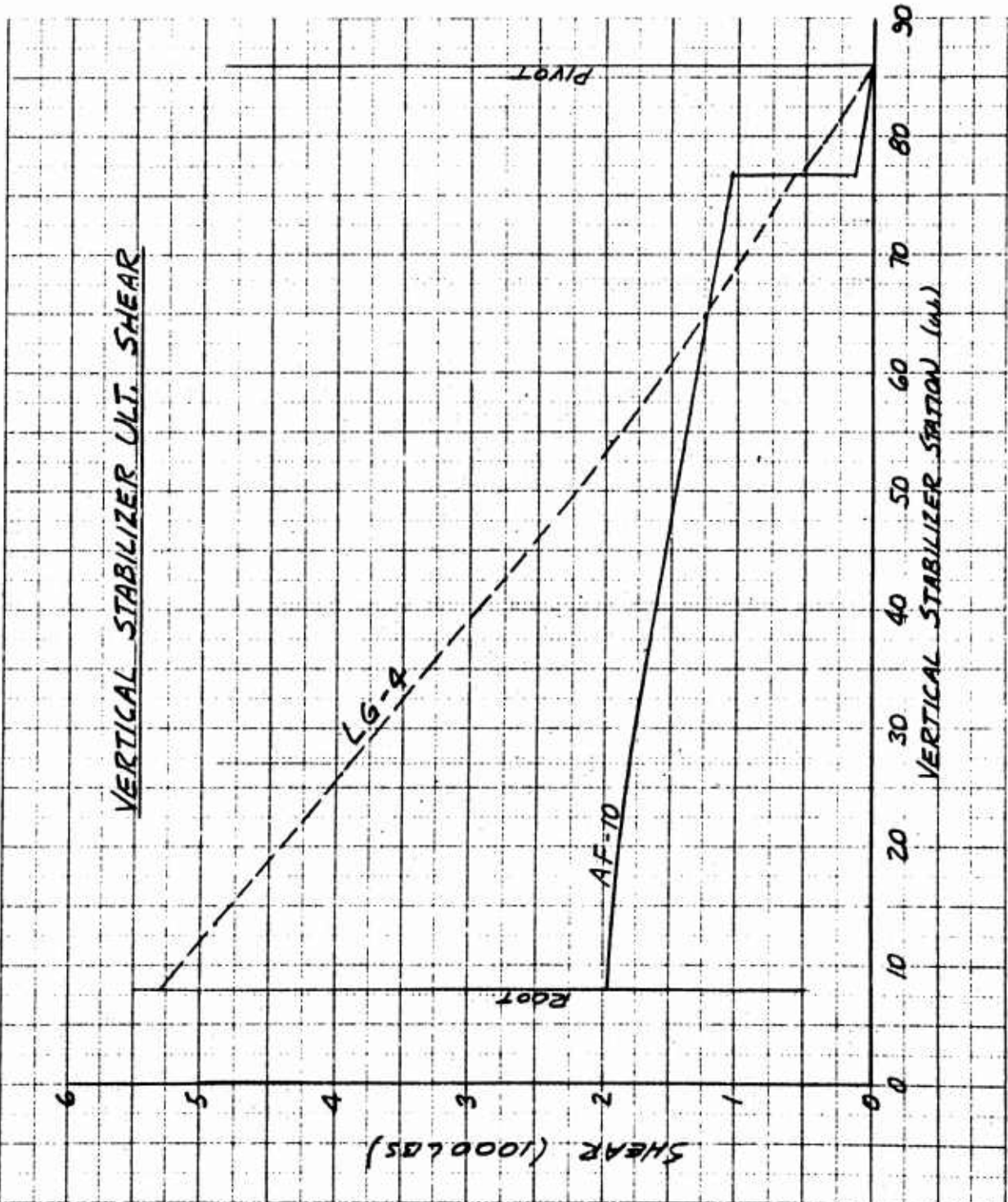

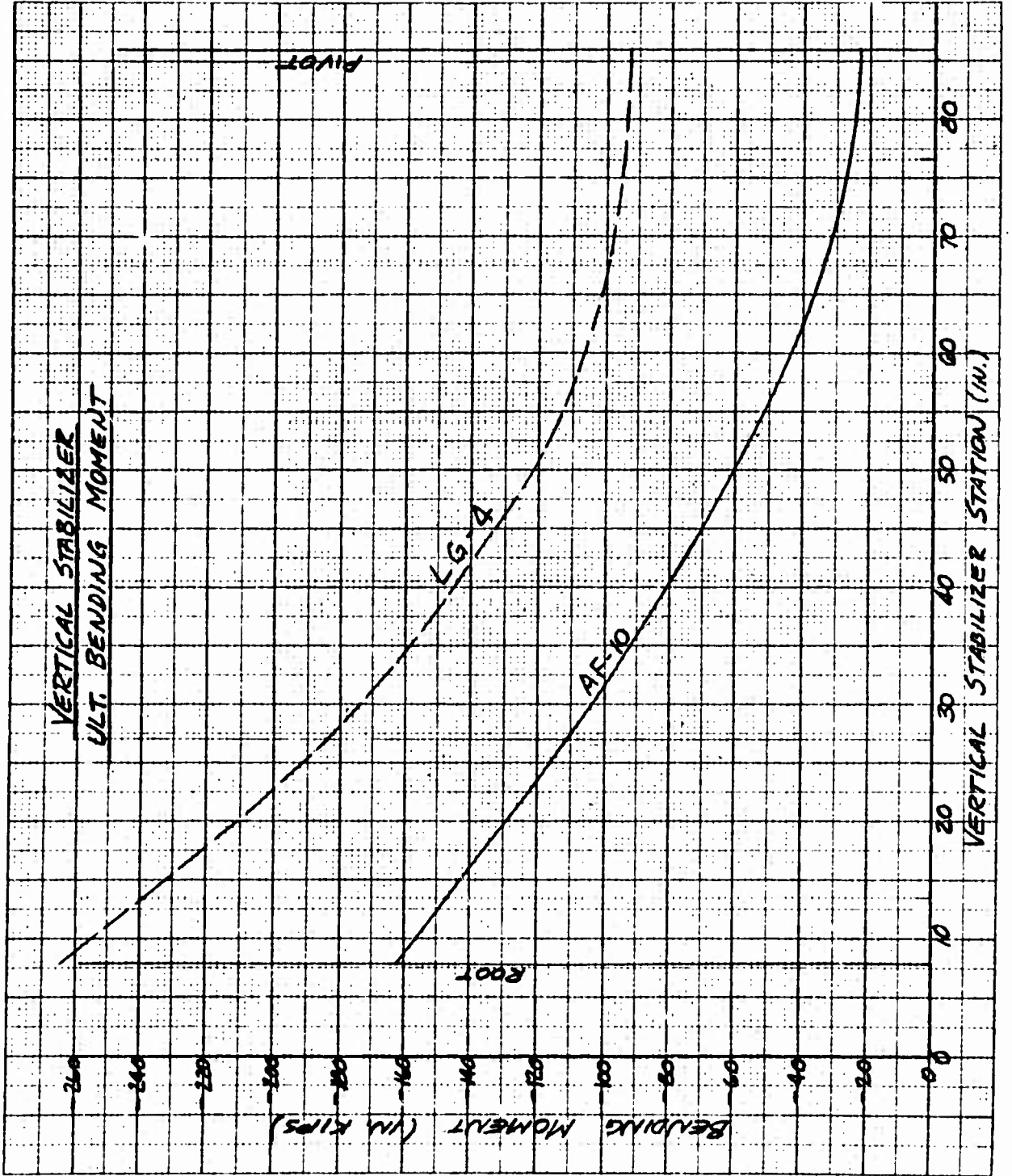

VERTICAL STABILIZER ULT. TORSION

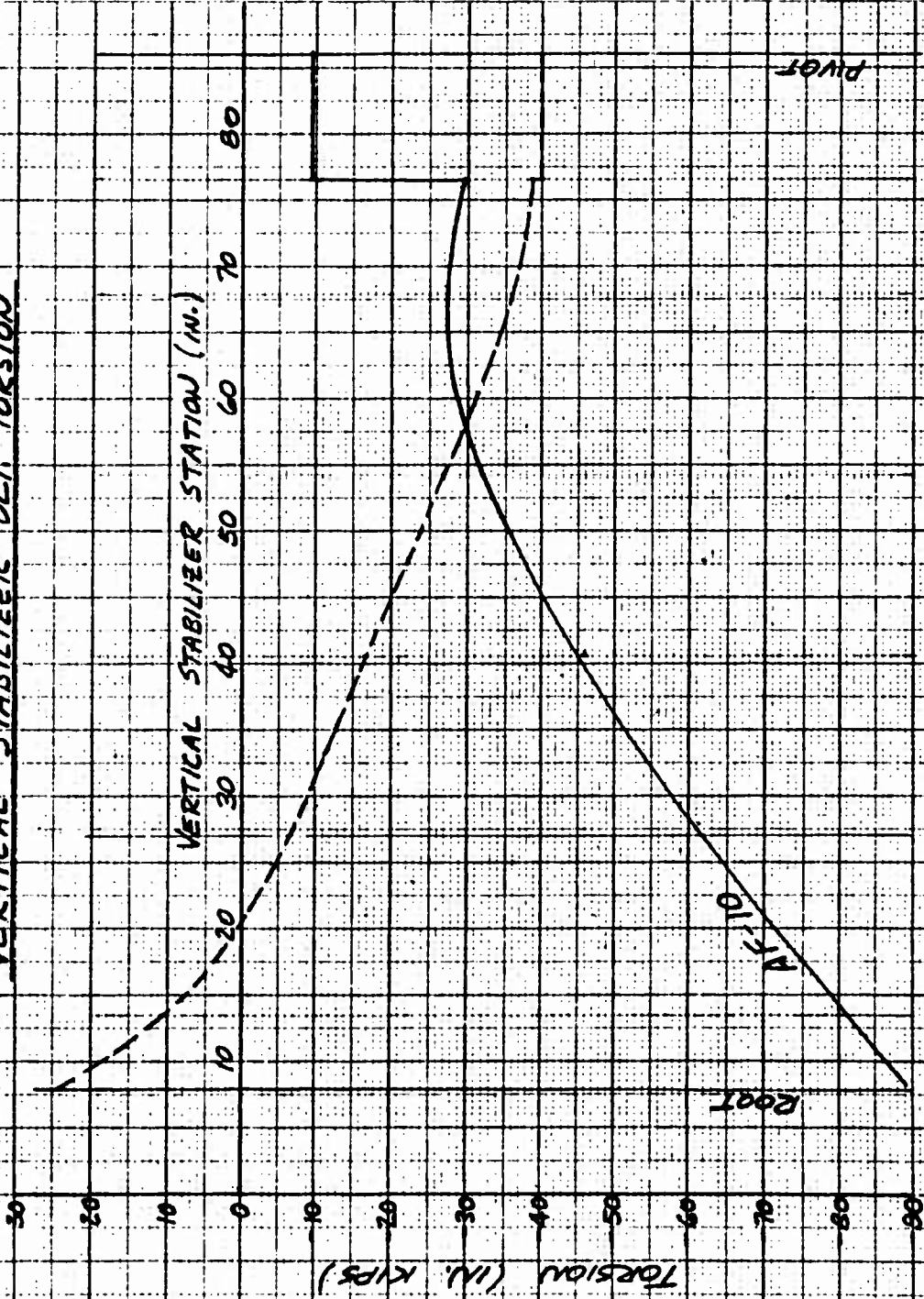

Lambert
7/22/63

VERTICAL STABILIZER
(DWG 143 T 003)

FRONT SPAR CAP AREAS (DWG. 143 T 005)

CONSTANT SECTION FROM ROOT TO STA. 67.80

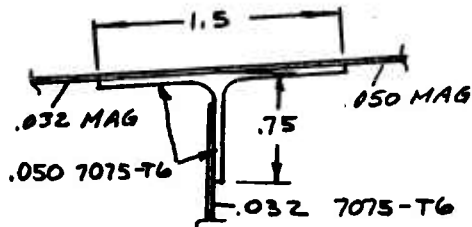

EFF. t OF MAG. SKINS

$$t_e (.050) = \frac{6.5}{10.5} \times .050 = .031$$

$$t_e (.032) = \frac{6.5}{10.5} \times .032 = .020$$

ASSUME 15 t EFFECTIVE WIDTH
OF SKIN ON EACH SIDE OF RIVET

AREA :

TEE	=	.110
.050 SKIN $(.38 + 15 \times .031) \cdot 051$	=	.0262
.032 SKIN $(.38 + 15 \times .02) \cdot 02$	=	.0136
.032 WEB $(.31 + 15 \times .032) \cdot 032$	=	.0252
		<u>.1750</u>

CRIPPLING ALLOWABLE :

(REF BOEING DESIGN MANUAL FIG. 1 SECT. 15.231)

$$\frac{A}{\sum t^2} = \frac{.11}{3 \times .05^2} = 14.7$$

$$F_{cr} = 42500 \text{ psi}$$

Fambur
7/23/63

VERTICAL STABILIZER

CENTER SPAR CAP AREAS (DWG. 143 T 007)

CONSTANT SECTION FROM V.S.S. 13.40 TO 67.80

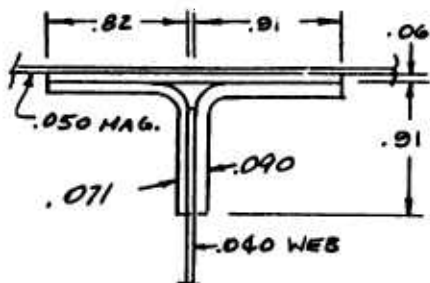

ALL MAT'L 7075-T6 EXCEPT
SKIN

AREA :	.071 ANGLE	= .112
	.090 ANGLE	= .148
	.060 STRAP	= .106
	.050 SKIN $(1.01 + 30 \times .031) \cdot 031$	= .06
	.040 WEB $(.31 + 15 \times .04) \cdot 04$	= .036
		<u>.462</u>

CRIPPLING ALLOWABLE :

(REF. RYAN STRUCTURES MANUAL)

$$.090 \text{ ANGLE} \quad b'/t = 1865 / .09 = 9.6$$

$$F_{cr} = .057 \sqrt{68000 \times 10.5 \times 10^6} = 48100 \text{ psi}$$

$$.071 \text{ ANGLE} \quad b'/t = \frac{.784 + .864}{2 \times .071} = 11.6$$

$$F_{cr} = .05 \sqrt{68000 \times 10.5 \times 10^6} = 42300 \text{ psi}$$

$$\text{AV. } F_{cr} = \frac{48100 \times .148 + 42300 \times .112}{.148 + .112}$$

$$= 45600 \text{ psi}$$

Lambert
7/23/63

VERTICAL STABILIZER

REAR SPAR CAP AREAS (DWG. 143 T 009)

SECTION @ V.S.S. 13.40

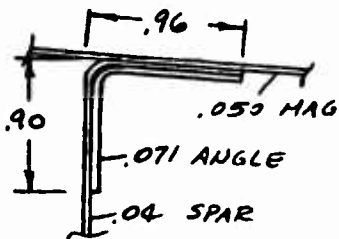

AREA SPAR	=	.071
" ANGLE	=	.116
" SKIN (30 x .031) .031	=	.029
		<u>.216</u>

CRIPPLING ALLOWABLE

.040 FLG. $b/t = .94 / .040 = 23.5$

$$F_{cc} = .03 \sqrt{68000 \times 10.5 \times 10^6} = 20400 \text{ psi}$$

.071 ANGLE $b/t = \frac{.844 + .904}{2 \times .071} = 12.3$

$$F_{cc} = .047 \sqrt{68000 \times 10.5 \times 10^6} = 39800 \text{ psi}$$

$$\text{Av. } F_{cc} = \frac{20400 \times .071 + 39800 \times .116}{.071 + .116} = 32400 \text{ psi}$$

SECTION FROM V.S.S. 20.20 TO V.S.S. 40.60

DEPTH OF .071 ANGLE IS REDUCED TO .72

AREA SPAR	=	.064
" ANGLE	=	.104
" SKIN	=	.029
		<u>.197</u>

b/t (OF .071 ANGLE) $= \frac{.609 + .904}{2 \times .071} = 10.7$

$$F_{cc} = .053 \sqrt{68000 \times 10.5 \times 10^6} = 44900 \text{ psi}$$

$$\text{Av. } F_{cc} = \frac{20400 \times .064 + 44900 \times .104}{.064 + .104} = 35600 \text{ psi}$$

Lambert
7/23/63

VERTICAL STABILIZER

REAR SPAR CAP AREAS

SECTION FROM V.S.S. 47.40 TO 77.75

NESTED .071 ANGLE IS DROPPED AT V.S.S. 40.60
AND SPAR FLANGE WIDTH IS REDUCED TO .78
AT V.S.S. 47.40

$$\begin{aligned} \text{AREA SPAR} &= .059 \\ \text{" SKIN} &= \frac{.1029}{.088} \end{aligned}$$

CRIPPLING ALLOWABLE :

$$.040 \text{ FLG.} - \quad b/t = .76/.04 = 19$$

$$F_{CC} = .034 \sqrt{68000 \times 10.5 \times 10^6} = 28800 \text{ psi}$$

TYPICAL SECTION VERTICAL STABILIZER

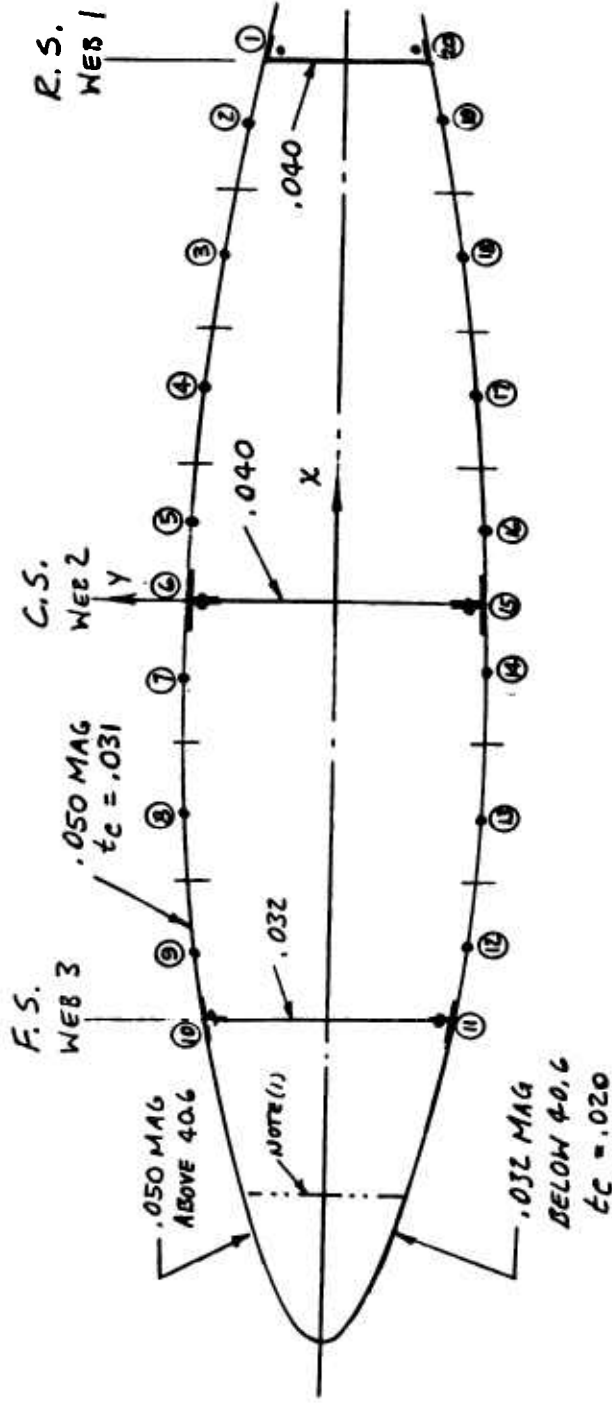

ONLY SKIN IN TENSION IS CONSIDERED EFFECTIVE.
 NO SKIN IS CONSIDERED EFFECTIVE AT V.S.S. 13.40
 BECAUSE OF DISCONTINUITY AT FUSELAGE INTERSECTION.

NOTE (1) LEADING EDGE OF SECTION @ V.S.S. 13.40 IS ASSUMED TO
 TERMINATE ON DORSAL FRAME F.S. 432.80.

JOB NO. 1012

BOX BEAM ANALYSIS
MODEL XV-5A
VERTICAL TAIL
STATION 13.40

22 AUG 63

SECTION INPUT DATA

WIDTH TOL.	R(STG)	R(PLATE)	W/T	G/1E6	
0.050	1.000	1.000	20.00	3.900	
C	X0/C	R(WEB)	2A(TE)	DS(TE)	
60.28	0.5600	1.000	0.	0.	
T(TE)	2A(LE)	DS(LE)	T(LE)		
0.	332.00	37.900	0.0200		
FP(MAX)	FP(MIN)	FS(MIN)	QP(MAX)		
45000.	-30000.	-45600.	500.		
WEB	XW(U)	YW(U)	XW(L)	YW(L)	TW
1	26.52	4.05	26.52	-4.05	0.0400
2	0.	7.25	0.	-7.25	0.0400
3	-20.56	6.80	-20.56	-6.80	0.0320

JOB NO. 1012

BOX BEAM ANALYSIS
 MODEL XV-5A
 VERTICAL TAIL
 STATION 13.40

22 AUG 63

SECTION INPUT DATA

ITEM	X(S)	Y(S)	A(S)	IXOS	IYOS	IXYOS	X(P)	Y(P)	T(P)	E/1E6
1	26.77	3.80	0.22	-0.	-0.	-0.	26.52	4.05	-0.031	0.
2	23.21	4.60	0.	-0.	-0.	-0.	23.21	4.60	-0.031	0.
3	16.59	5.61	0.	-0.	-0.	-0.	16.59	5.61	-0.031	0.
4	9.97	6.44	0.	-0.	-0.	-0.	9.97	6.44	-0.031	0.
5	3.35	7.06	0.	-0.	-0.	-0.	3.35	7.06	-0.031	0.
6	0.	7.00	0.46	-0.	-0.	-0.	0.	7.25	-0.031	0.
7	-3.42	7.33	0.	-0.	-0.	-0.	-3.42	7.33	-0.031	0.
8	-10.26	7.25	0.	-0.	-0.	-0.	-10.26	7.25	-0.031	0.
9	-17.10	6.98	0.	-0.	-0.	-0.	-17.10	6.98	-0.031	0.
10	-20.56	6.55	0.17	-0.	-0.	-0.	-20.56	6.80	-0.031	0.
11	-20.56	-6.55	0.17	-0.	-0.	-0.	-20.56	-6.80	-0.031	0.
12	-17.10	-6.98	0.	-0.	-0.	-0.	-17.10	-6.98	-0.031	0.
13	-10.26	-7.25	0.	-0.	-0.	-0.	-10.26	-7.25	-0.031	0.
14	-3.42	-7.33	0.	-0.	-0.	-0.	-3.42	-7.33	-0.031	0.
15	0.	-7.00	0.46	-0.	-0.	-0.	0.	-7.25	-0.031	0.
16	3.35	-7.06	0.	-0.	-0.	-0.	3.35	-7.06	-0.031	0.
17	9.97	-6.44	0.	-0.	-0.	-0.	9.97	-6.44	-0.031	0.
18	16.59	-5.61	0.	-0.	-0.	-0.	16.59	-5.61	-0.031	0.
19	23.21	-4.60	0.	-0.	-0.	-0.	23.21	-4.60	-0.031	0.
20	26.77	-3.80	0.22	-0.	-0.	-0.	26.52	-4.05	-0.031	0.

JOB NO. 1012

BOX BEAM ANALYSIS
MODEL XV-5A
VERTICAL TAIL
STATION 13.40

22 AUG 63

CONDITION AF-10

SX -1940.	SY -0.	MXX -146900.	MYX -0.	T 81200.
	NO. IT. 2	QXP(N) 0.00000	QYP(N) -0.	
IX(NA) 6.65300E 01	IY(NA) 4.46348E 02	IXY(NA) 9.53954E-08	XBAR 2.56075E 00	YBAR -2.18364E-08
IX(NA)F 6.65300E 01	IY(NA)F 4.46348E 02	IXY(NA)F 9.53954E-08	XBARF 2.56075E 00	YBARF -2.18364E-08
AP(EFF) 0.	AP(FULL) -2.93257E 00	A(TRUE) 8.70626E-01	2A(CELLS) 1.54781E 03	
	THETA X (RADIAN) 2.38282E-06	THETA Y (RADIAN) -0.	THETA T (RADIAN) -2.97379E-05	
	S.C.(X) 3.35378E 00	S.C.(X/C) 6.15637E-01	S.C.(Y) -0.	

NET WEB AND INTERNAL CELL SHEAR FLOWS

WEB	1	6.5545
CELL	1	6.5545
WEB	2	-270.7479
CELL	2	277.3024
WEB	3	117.8918
CELL	3	7.7491

JOB NO. 1012

BOX BEAM ANALYSIS
 MODEL XV-5A
 VERTICAL TAIL
 STATION 13.40

22 AUG 63

CONDITION AF-10

ITEM	WP(EFF)	F(P)	F(S)	QP(NET)
WEB 1				6.5545
1	0.	8942.51	8390.51	-17.3799
2	0.	10156.93	10156.93	-17.3799
3	0.	12387.04	12387.04	-17.3799
4	0.	14219.70	14219.70	-17.3799
5	0.	15588.68	15588.68	-17.3799
WEB 2				253.3681
6	0.	16008.20	15456.20	159.0653
7	0.	16184.85	16184.85	159.0653
8	0.	16008.20	16008.20	159.0653
9	0.	15412.04	15412.04	159.0653
10	0.	15014.59	14462.58	125.6409
WEB 3				125.6409
11	-0.	-15014.59	-14462.58	159.0653
12	-0.	-15412.04	-15412.04	159.0653
13	-0.	-16008.20	-16008.20	159.0653
14	-0.	-16184.85	-16184.85	159.0653
15	-0.	-16008.20	-15456.20	253.3681
WEB 2				-17.3799
16	-0.	-15588.68	-15588.68	-17.3799
17	-0.	-14219.70	-14219.70	-17.3799
18	-0.	-12387.04	-12387.04	-17.3799
19	-0.	-10156.93	-10156.93	-17.3799
20	-0.	-8942.51	-8390.51	6.5545
WEB 1				0.0000

JOB NO. 1012

BOX BEAM ANALYSIS
MODEL XV-5A
VERTICAL TAIL
STATION 13.40

22 AUG 63

CONDITION LG-4

SX	SY	MXX	MYX	T
-4890.	-0.	-239000.	-0.	-10700.
	NO. IT.	QXP(N)	QYP(N)	
	2	0.00000	-0.	
IX(NA)	IY(NA)	IXY(NA)	XBAR	YBAR
6.65300E 01	4.46348E 02	9.53954E-08	2.56075E 00	-2.18364E-08
IX(NA)F	IY(NA)F	IXY(NA)F	XBARF	YBARF
6.65300E 01	4.46348E 02	9.53954E-08	2.56075E 00	-2.18364E-08
API(EFF)	AP(FULL)	A(TRUE)	2A(CELLS)	
0.	-2.93257E 00	8.70626E-01	1.54781E 03	
	THETA X (RADIAN)	THETA Y (RADIAN)	THETA T (RADIAN)	
	6.00618E-06	-0.	3.91867E-06	
	S.C.(X)	S.C.(X/C)	S.C.(Y)	
	3.35378E 00	6.15637E-01	-0.	

NET WEB AND INTERNAL CELL SHEAR FLOWS

WEB	1	-63.1077
CELL	1	-63.1077
WEB	2	-485.0249
CELL	2	421.9172
WEB	3	26.8362
CELL	3	12.8000

JOB NO. 1012

BOX BEAM ANALYSIS
 MODEL XV-5A
 VERTICAL TAIL
 STATION 13.40

22 AUG 63

CONDITION LG-4

ITEM	WP(EFF)	F(P)	F(S)	QP(NET)
WEB 1				-63.1077
1	0.	14549.09	13650.99	-123.4371
2	0.	16524.89	16524.89	-123.4371
3	0.	20153.18	20153.18	-123.4371
4	0.	23134.84	23134.84	-123.4371
5	0.	25362.11	25362.11	-123.4371
WEB 2				361.5878
6	0.	26044.66	25146.57	123.8865
7	0.	26332.05	26332.05	123.8865
8	0.	26044.66	26044.66	123.8865
9	0.	25074.72	25074.72	123.8865
10	0.	24428.09	23530.00	39.6363
WEB 3				39.6363
11	-0.	-24428.09	-23530.00	123.8865
12	-0.	-25074.72	-25074.72	123.8865
13	-0.	-26044.66	-26044.66	123.8865
14	-0.	-26332.05	-26332.05	123.8865
15	-0.	-26044.66	-25146.57	361.5878
WEB 2				-123.4371
16	-0.	-25362.11	-25362.11	-123.4371
17	-0.	-23134.84	-23134.84	-123.4371
18	-0.	-20153.18	-20153.18	-123.4371
19	-0.	-16524.89	-16524.89	-123.4371
20	-0.	-14549.09	-13650.99	-63.1077
WEB 1				0.0000

JOB NO. 1012

BOX BEAM ANALYSIS
MODEL XV-5A
VERTICAL TAIL
STATION 27.00

22 AUG 63

SECTION INPUT DATA

WIDTH TOL.	R(STG)	R(PLATE)	W/T	G/1E6	
0.050	1.000	1.000	20.00	3.900	
C	X0/C	R(WEB)	2A(TE)	DS(TE)	
61.48	0.6000	1.000	0.	0.	
T(TE)	2A(LE)	DS(LE)	T(LE)		
0.	273.00	38.300	0.0200		
FP(MAX)	FP(MIN)	FS(MIN)	QP(MAX)		
45000.	-30000.	-45600.	500.		
WEB	XW(U)	YW(U)	XW(L)	YW(L)	TW
1	24.60	3.70	24.60	-3.70	0.0400
2	0.	6.59	0.	-6.59	0.0400
3	-19.10	5.77	-19.10	-5.77	0.0320

JOB NO. 1012

BOX BEAM ANALYSIS
 MODEL XV-5A
 VERTICAL TAIL
 STATION 27.00

22 AUG 63

SECTION INPUT DATA

ITEM	X(S)	Y(S)	A(S)	IXOS	IYOS	IXYOS	X(P)	Y(P)	T(P)	E/1E6
1	24.85	3.45	0.20	-0.	-0.	-0.	24.60	3.70	0.031	0.
2	21.52	4.17	0.	-0.	-0.	-0.	21.52	4.17	0.031	0.
3	15.36	5.08	0.	-0.	-0.	-0.	15.36	5.08	0.031	0.
4	9.20	5.85	0.	-0.	-0.	-0.	9.20	5.85	0.031	0.
5	3.04	6.41	0.	-0.	-0.	-0.	3.04	6.41	0.031	0.
6	0.	6.34	0.46	-0.	-0.	-0.	0.	6.59	0.031	0.
7	-3.18	6.66	0.	-0.	-0.	-0.	-3.18	6.66	0.031	0.
8	-9.54	6.52	0.	-0.	-0.	-0.	-9.54	6.52	0.031	0.
9	-15.90	6.08	0.	-0.	-0.	-0.	-15.90	6.08	0.031	0.
10	-19.10	5.52	0.17	-0.	-0.	-0.	-19.10	5.77	0.031	0.
11	-19.10	-5.52	0.17	-0.	-0.	-0.	-19.10	-5.77	0.031	0.
12	-15.90	-6.08	0.	-0.	-0.	-0.	-15.90	-6.08	0.031	0.
13	-9.54	-6.52	0.	-0.	-0.	-0.	-9.54	-6.52	0.031	0.
14	-3.18	-6.66	0.	-0.	-0.	-0.	-3.18	-6.66	0.031	0.
15	0.	-6.34	0.46	-0.	-0.	-0.	0.	-6.59	0.031	0.
16	3.04	-6.41	0.	-0.	-0.	-0.	3.04	-6.41	0.031	0.
17	9.20	-5.85	0.	-0.	-0.	-0.	9.20	-5.85	0.031	0.
18	15.36	-5.08	0.	-0.	-0.	-0.	15.36	-5.08	0.031	0.
19	21.52	-4.17	0.	-0.	-0.	-0.	21.52	-4.17	0.031	0.
20	24.85	-3.45	0.20	-0.	-0.	-0.	24.60	-3.70	0.031	0.

JOB NO. 1012

BOX BEAM ANALYSIS
MODEL XV-5A
VERTICAL TAIL
STATION 27.00

22 AUG 63

CONDITION AF-10

SX -1812.	SY -0.	MXX -111100.	MY Y -0.	T 61600.
	NO. IT. 2	QXP(N) 0.00000	QYP(N) 0.	
IX(NA) 7.88959E 01	IY(NA) 5.82907E 02	IXY(NA) -7.44628E 00	XBAR 2.27927E 00	YBAR 2.61688E 00
IX(NA)F 7.88959E 01	IY(NA)F 5.82907E 02	IXY(NA)F -7.44628E 00	XBARF 2.27927E 00	YBARF 2.61688E 00
AP(EFF) 1.36132E 00	AP(FULL) 2.72265E 00	A(TRUE) 6.34913E 00	2A(CELLS) 1.28821E 03	
	THETA X (RADIANS) 2.24808E-06	THETA Y (RADIANS) -0.	THETA T (RADIANS) 4.25142E-05	
	S.C.(X) -1.79763E 00	S.C.(X/C) 5.70761E-01	S.C.(Y) 0.	

NET WEB AND INTERNAL CELL SHEAR FLOWS

WEB	1	90.1642
CELL	1	90.1642
WEB	2	-81.0033
CELL	2	171.1675
WEB	3	-7.7434
CELL	3	23.4287

JOB NO. 1012

BOX BEAM ANALYSIS
 MODEL XV-5A
 VERTICAL TAIL
 STATION 27.00

22 AUG 63

CONDITION AF-10

ITEM	WP(EFF)	F(P)	F(S)	QP(NET)
WEB 1				90.1642
1	1.5578	1929.07	1581.10	83.4452
2	4.6713	2536.25	2536.25	77.1053
3	6.2174	3708.30	3708.30	65.4508
4	6.1967	4682.96	4682.96	50.7813
5	4.6154	5361.55	5361.55	38.4441
WEB 2				119.4475
6	3.1130	5560.58	5208.11	71.4499
7	4.7712	5602.00	5602.00	57.9907
8	6.3684	5290.07	5290.07	40.9584
9	4.7951	4555.18	4555.18	29.6693
10	1.6075	4060.48	3708.01	15.6853
WEB 3				15.6853
11	0.	-12209.59	-11857.12	49.5277
12	0.	-12589.02	-12589.02	49.5277
13	0.	-13094.82	-13094.82	49.5277
14	0.	-13177.66	-13177.66	49.5277
15	0.	-13021.69	-12669.22	144.9909
WEB 2				63.9876
16	0.	-12713.16	-12713.16	63.9876
17	0.	-11812.68	-11812.68	63.9876
18	0.	-10616.13	-10616.13	63.9876
19	0.	-9222.19	-9222.19	63.9876
20	0.	-8504.07	-8147.10	90.1642
WEB 1				0.0000

JOB NO. 1012

BOX BEAM ANALYSIS
MODEL XV-5A
VERTICAL TAIL
STATION 27.00

22 AUG 63

CONDITION LG-4

SX	SY	MXX	MYY	T
-3900.	-0.	-184500.	-0.	3300.
	NO. IT.	QXP(N)	QYP(N)	
	2	0.00000	0.	
IX(NA)	IY(NA)	IXY(NA)	XBAR	YBAR
7.88959E 01	5.82907E 02	-7.44628E 00	2.27927E 00	2.61688E 00
IX(NA)F	IY(NA)F	IXY(NA)F	XBARF	YBARF
7.88959E 01	5.82907E 02	-7.44628E 00	2.27927E 00	2.61688E 00
AP(EFF)	AP(FULL)	A(TRUE)	2A(CELLS)	
1.36132E 00	2.72265E 00	6.34913E 00	1.28821E 03	
	THETA X (RADIAN)	THETA Y (RADIAN)	THETA T (RADIAN)	
	4.83858E-06	-0.	2.27755E-06	
	S.C.(X)	S.C.(X/C)	S.C.(Y)	
	-1.79763E 00	5.70761E-01	0.	

NET WEB AND INTERNAL CELL SHEAR FLOWS

WEB	1	88.9242
CELL	1	88.9242
WEB	2	-161.9219
CELL	2	250.8461
WEB	3	-73.8503
CELL	3	-9.9508

JOB NO. 1012

 BOX BEAM ANALYSIS
 MODEL XV-5A
 VERTICAL TAIL
 STATION 27.00

22 AUG 63

CONDITION LG-4

ITEM	WPI(EFF)	F(P)	F(S)	QP(NET)
WEB 1				88.9242
1	1.5578	3203.55	2625.69	74.4627
2	4.6713	4211.86	4211.86	60.8172
3	6.2174	6158.24	6158.24	35.7330
4	6.1967	7776.84	7776.84	4.1596
5	4.6154	8903.75	8903.75	-22.3938
WEB 2				139.5281
6	3.1130	9234.27	8648.93	36.2222
7	4.7712	9303.05	9303.05	7.2536
8	6.3684	8785.04	8785.04	-29.4053
9	4.7951	7564.63	7564.63	-53.7030
10	1.6075	6743.10	6157.76	-83.8010
WEB 3				-83.8010
11	0.	-20276.05	-19690.71	-10.9614
12	0.	-20906.15	-20906.15	-10.9614
13	0.	-21746.12	-21746.12	-10.9614
14	0.	-21883.69	-21883.69	-10.9614
15	0.	-21624.68	-21039.35	194.5058
WEB 2				32.5838
16	0.	-21112.32	-21112.32	32.5838
17	0.	-19616.92	-19616.92	32.5838
18	0.	-17629.84	-17629.84	32.5838
19	0.	-15314.98	-15314.98	32.5838
20	0.	-14122.42	-13529.61	88.9242
WEB 1				0.0000

JOB NO. 1012

BOX BEAM ANALYSIS
MODEL XV-5A
VERTICAL TAIL
STATION 40.60

22 AUG 63

SECTION INPUT DATA

WIDTH TOL.	R(STG)	R(PLATE)	W/T	G/IE6	
0.050	1.000	1.000	20.00	3.900	
C	XO/C	R(WEB)	2A(TE)	DS(TE)	
53.64	0.6000	1.000	0.	0.	
T(TE)	2A(LE)	DS(LE)	T(LE)		
0.	177.00	29.000	0.0200		
FP(MAX)	FP(MIN)	FS(MIN)	QP(MAX)		
45000.	-30000.	-45600.	500.		
WEB	XW(U)	YW(U)	XW(L)	YW(L)	TW
1	22.74	3.32	22.74	-3.32	0.0400
2	0.	5.92	0.	-5.92	0.0400
3	-17.64	4.98	-17.64	-4.98	0.0320

JOB NO. 1012

 BOX BEAM ANALYSIS
 MODEL XV-5A
 VERTICAL TAIL
 STATION 40.60

22 AUG 63

SECTION INPUT DATA

ITEM	X(S)	Y(S)	A(S)	IXOS	IYOS	IXYOS	X(P)	Y(P)	T(P)	E/1E6
1	23.00	3.07	0.20	-0.	-0.	-0.	22.74	3.32	0.031	0.
2	19.90	3.77	0.	-0.	-0.	-0.	19.90	3.77	0.031	0.
3	14.22	4.59	0.	-0.	-0.	-0.	14.22	4.59	0.031	0.
4	8.54	5.27	0.	-0.	-0.	-0.	8.54	5.27	0.031	0.
5	2.86	5.75	0.	-0.	-0.	-0.	2.86	5.75	0.031	0.
6	0.	5.67	0.46	-0.	-0.	-0.	0.	5.92	0.031	0.
7	-2.94	5.98	0.	-0.	-0.	-0.	-2.94	5.98	0.031	0.
8	-8.82	5.85	0.	-0.	-0.	-0.	-8.82	5.85	0.031	0.
9	-14.70	5.35	0.	-0.	-0.	-0.	-14.70	5.35	0.031	0.
10	-17.64	4.73	0.17	-0.	-0.	-0.	-17.64	4.98	0.031	0.
11	-17.64	-4.73	0.17	-0.	-0.	-0.	-17.64	-4.98	0.031	0.
12	-14.70	-5.35	0.	-0.	-0.	-0.	-14.70	-5.35	0.031	0.
13	-8.82	-5.85	0.	-0.	-0.	-0.	-8.82	-5.85	0.031	0.
14	-2.94	-5.98	0.	-0.	-0.	-0.	-2.94	-5.98	0.031	0.
15	0.	-5.67	0.46	-0.	-0.	-0.	0.	-5.92	0.031	0.
16	2.86	-5.75	0.	-0.	-0.	-0.	2.86	-5.75	0.031	0.
17	8.54	-5.27	0.	-0.	-0.	-0.	8.54	-5.27	0.031	0.
18	14.22	-4.59	0.	-0.	-0.	-0.	14.22	-4.59	0.031	0.
19	19.90	-3.77	0.	-0.	-0.	-0.	19.90	-3.77	0.031	0.
20	23.00	-3.07	0.20	-0.	-0.	-0.	22.74	-3.32	0.031	0.

JOB NO. 1012

BOX BEAM ANALYSIS
MODEL XV-5A
VERTICAL TAIL
STATION 40.60

22 AUG 63

CONDITION AF-10

SX -1609.	SY -0.	MXX -79600.	MYX -0.	T 45500.
	NO. IT. 2	QXP(N) -0.00000	QYP(N) -0.	
IX(NA) 6.15188E 01	IY(NA) 4.84259E 02	IXY(NA) -5.10085E 00	XBAR 2.09606E 00	YBAR 2.24549E 00
IX(NA)F 6.15188E 01	IY(NA)F 4.84259E 02	IXY(NA)F -5.10085E 00	XBARF 2.09606E 00	YBARF 2.24549E 00
API(EFF) 1.25819E 00	AP(FULL) 2.51637E 00	A(TRUE) 5.82229E 00	2A(CELLS) 1.01774E 03	
	THETA X (RADIAN) 2.22612E-06	THETA Y (RADIAN) 0.	THETA T (RADIAN) 4.33959E-05	
	S.C.(X) -1.45063E 00	S.C.(X/C) 5.72956E-01	S.C.(Y) -0.	

NET WEB AND INTERNAL CELL SHEAR FLOWS

WEB	1	85.8066
CELL	1	85.8066
WEB	2	-80.4876
CELL	2	166.2943
WEB	3	-8.7312
CELL	3	19.8450

JOB NO. 1012

BOX BEAM ANALYSIS
 MODEL XV-5A
 VERTICAL TAIL
 STATION 40.60

22 AUG 63

CONDITION AF-10

ITEM	WP(EFF)	F(P)	F(S)	QP(NET)
WEB 1				85.8066
1	1.4377	1673.15	1352.94	78.7893
2	4.3072	2217.18	2217.18	72.4624
3	5.7297	3201.63	3201.63	60.9699
4	5.7104	4004.78	4004.78	46.6419
5	4.2826	4548.92	4548.92	34.5956
WEB 2				115.0832
6	2.9028	4730.07	4406.30	65.3290
7	4.4110	4767.66	4767.66	52.1996
8	5.8913	4519.10	4519.10	35.5183
9	4.4322	3791.37	3791.37	24.7015
10	1.4816	3272.09	2948.33	11.1138
WEB 3				11.1138
11	0.	-9626.55	-9302.78	44.0212
12	0.	-10065.61	-10065.61	44.0212
13	0.	-10632.92	-10632.92	44.0212
14	0.	-10721.07	-10721.07	44.0212
15	0.	-10603.26	-10279.50	140.0180
WEB 2				59.5304
16	0.	-10344.09	-10344.09	59.5304
17	0.	-9644.98	-9644.98	59.5304
18	0.	-8686.87	-8686.87	59.5304
19	0.	-7547.45	-7547.45	59.5304
20	0.	-6925.94	-6598.64	85.8066
WEB 1				-0.0000

JOB NO. 1012

BOX BEAM ANALYSIS
MODEL XV-5A
VERTICAL TAIL
STATION 40.60

22 AUG 63

CONDITION LG-4

SX	SY	MXX	MYX	T
-2900.	-0.	-144100.	-0.	15800.
	NO. IT.	QXP(N)	QYP(N)	
	2	-0.00000	-0.	
IX(NA)	IY(NA)	IXY(NA)	XBAR	YBAR
6.15188E 01	4.84259E 02	-5.10085E 00	2.09606E 00	2.24549E 00
IX(NA)F	IY(NA)F	IXY(NA)F	XBARF	YBARF
6.15188E 01	4.84259E 02	-5.10085E 00	2.09606E 00	2.24549E 00
AP(EFF)	AP(FULL)	A(TRUE)	2A(CELLS)	
1.25819E 00	2.51637E 00	5.82229E 00	1.01774E 03	
	THETA X	THETA Y	THETA T	
	(RADIANS)	(RADIANS)	(RADIANS)	
	4.01228E-06	0.	1.50693E-05	
	S.C.(X)	S.C.(X/C)	S.C.(Y)	
	-1.45063E 00	5.72956E-01	-0.	

NET WEB AND INTERNAL CELL SHEAR FLOWS

WEB	1	37.4871
CELL	1	87.4871
WEB	2	-137.5457
CELL	2	225.0328
WEB	3	-52.4781
CELL	3	-2.1805

JOB NO. 1012

BOX BEAM ANALYSIS
 MODEL XV-5A
 VERTICAL TAIL
 STATION 40.60

22 AUG 63

CONDITION LG-4

ITEM	WP(EFF)	F(P)	F(S)	QP(NET)
WEB 1				87.4871
1	1.4377	3028.91	2449.22	74.8393
2	4.3072	4013.76	4013.76	63.4359
3	5.7297	5795.92	5795.92	42.7224
4	5.7104	7249.86	7249.86	16.8981
5	4.2826	8234.92	8234.92	-4.8138
WEB 2				132.7319
6	2.9028	8562.85	7976.74	43.0569
7	4.4110	8630.91	8630.91	19.3929
8	5.8913	8180.93	8180.93	-10.6728
9	4.4322	6863.52	6863.52	-30.1687
10	1.4816	5923.48	5337.37	-54.6586
WEB 3				-54.6586
11	0.	-17426.95	-16840.84	4.6525
12	0.	-18221.78	-18221.78	4.6525
13	0.	-19248.79	-19248.79	4.6525
14	0.	-19408.36	-19408.36	4.6525
15	0.	-19195.09	-18608.99	177.6735
WEB 2				40.1278
16	0.	-18725.92	-18725.92	40.1278
17	0.	-17460.33	-17460.33	40.1278
18	0.	-15725.86	-15725.86	40.1278
19	0.	-13663.17	-13663.17	40.1278
20	0.	-12538.05	-11945.52	87.4871
WEB 1				-0.0000

JOB NO. 1012

BOX BEAM ANALYSIS
MODEL XV-5A
VERTICAL TAIL
STATION 54.20

22 AUG 63

SECTION INPUT DATA

WIDTH TOL.	R(STG)	R(PLATE)	W/T	G/IE6	
0.050	1.000	1.000	20.00	3.900	
C	X0/C	R(WEB)	2A(TE)	DS(TE)	
49.16	0.6000	1.000	0.	0.	
T(TE)	2A(LE)	DS(LE)	T(LE)		
0.	143.00	27.000	0.0310		
FP(MAX)	FP(MIN)	FS(MIN)	QP(MAX)		
45000.	-30000.	-45600.	500.		
WEB	XW(U)	YW(U)	XW(L)	YW(L)	TW
1	20.80	2.97	20.80	-2.97	0.0400
2	0.	5.28	0.	-5.28	0.0400
3	-16.14	4.40	-16.14	-4.40	0.0320

JOB NO. 1012

BOX BEAM ANALYSIS
 MODEL XV-5A
 VERTICAL TAIL
 STATION 54.20

22 AUG 63

SECTION INPUT DATA

ITEM	X(S)	Y(S)	A(S)	IXOS	IYOS	IXYOS	X(P)	Y(P)	T(P)	E/1E6
1	21.05	2.72	0.09	-0.	-0.	-0.	20.80	2.97	0.031	0.
2	18.20	3.35	0.	-0.	-0.	-0.	18.20	3.35	0.031	0.
3	13.00	4.08	0.	-0.	-0.	-0.	13.00	4.08	0.031	0.
4	7.80	4.69	0.	-0.	-0.	-0.	7.80	4.69	0.031	0.
5	2.60	5.13	0.	-0.	-0.	-0.	2.60	5.13	0.031	0.
6	0.	5.03	0.46	-0.	-0.	-0.	0.	5.28	0.031	0.
7	-2.69	5.33	0.	-0.	-0.	-0.	-2.69	5.33	0.031	0.
8	-8.07	5.20	0.	-0.	-0.	-0.	-8.07	5.20	0.031	0.
9	-13.45	4.74	0.	-0.	-0.	-0.	-13.45	4.74	0.031	0.
10	-16.14	4.15	0.17	-0.	-0.	-0.	-16.14	4.40	0.031	0.
11	-16.14	-4.15	0.17	-0.	-0.	-0.	-16.14	-4.40	0.031	0.
12	-13.45	-4.74	0.	-0.	-0.	-0.	-13.45	-4.74	0.031	0.
13	-8.07	-5.20	0.	-0.	-0.	-0.	-8.07	-5.20	0.031	0.
14	-2.69	-5.33	0.	-0.	-0.	-0.	-2.69	-5.33	0.031	0.
15	0.	-5.03	0.46	-0.	-0.	-0.	0.	-5.28	0.031	0.
16	2.60	-5.13	0.	-0.	-0.	-0.	2.60	-5.13	0.031	0.
17	7.80	-4.69	0.	-0.	-0.	-0.	7.80	-4.69	0.031	0.
18	13.00	-4.08	0.	-0.	-0.	-0.	13.00	-4.08	0.031	0.
19	18.20	-3.35	0.	-0.	-0.	-0.	18.20	-3.35	0.031	0.
20	21.05	-2.72	0.09	-0.	-0.	-0.	20.80	-2.97	0.031	0.

JOB NO. 1012

BOX BEAM ANALYSIS
MODEL XV-5A
VERTICAL TAIL
STATION 54.20

22 AUG 63

CONDITION AF-10

SX -1403.	SY -0.	MXX -53300.	MYX -0.	T 30900.
	NO. IT. 2	QXP(N) -0.00000	QYP(N) -0.	
IX(NA) 4.50691E 01	IY(NA) 3.06472E 02	IXY(NA) 4.89785E 00	XBAR 2.93598E-01	YBAR 2.05533E 00
IX(NA)F 4.50691E 01	IY(NA)F 3.06472E 02	IXY(NA)F 4.89785E 00	XBARF 2.93598E-01	YBARF 2.05533E 00
AP(EFF) 1.15073E 00	AP(FULL) 2.30145E 00	A(TRUE) 5.53005E 00	2A(CELLS) 8.27116E 02	
	THETA X (RADIAN) 4.52632E-06	THETA Y (RADIAN) 0.	THETA T (RADIAN) 3.83544E-05	
	S.C.(X) -2.59914E 00	S.C.(X/C) 5.47129E-01	S.C.(Y) -0.	

NET WEB AND INTERNAL CELL SHEAR FLOWS

WEB	1	68.4846
CELL	1	68.4846
WEB	2	-82.0372
CELL	2	150.5219
WEB	3	-19.2990
CELL	3	21.3640

JOB NO. 1012

BOX BEAM ANALYSIS
MODEL XV-5A
VERTICAL TAIL
STATION 54.20

22 AUG 63

CONDITION AF-10

ITEM	WP(EFF)	F(P)	F(S)	QP(NET)
WEB 1				68.4846
1	1.3138	695.35	394.44	66.6916
2	3.9393	1194.75	1194.75	62.4597
3	5.2433	2158.02	2158.02	53.2293
4	5.2271	2979.14	2979.14	40.5247
5	3.9115	3598.85	3598.85	29.2638
WEB 2				111.3011
6	2.6474	3825.78	3529.61	60.1095
7	4.0360	3935.94	3935.94	47.1309
8	5.3906	3883.79	3883.79	30.0480
9	4.0555	3440.69	3440.69	18.4436
10	1.3557	3088.83	2792.66	2.0650
WEB 3				2.0650
11	0.	-7336.41	-7040.24	34.4957
12	0.	-7790.14	-7790.14	34.4957
13	0.	-8436.95	-8436.95	34.4957
14	0.	-8692.82	-8692.82	34.4957
15	0.	-8684.52	-8388.34	136.5071
WEB 2				54.4698
16	0.	-8556.04	-8556.04	54.4698
17	0.	-8133.23	-8133.23	54.4698
18	0.	-7509.02	-7509.02	54.4698
19	0.	-6742.65	-6742.65	54.4698
20	0.	-6341.69	-6050.26	68.4846
WEB 1				-0.0000

JOB NO. 1012

BOX BEAM ANALYSIS
MODEL XV-5A
VERTICAL TAIL
STATION 54.20

22 AUG 63

CONDITION LG-4

SX -1970.	SY -0.	MXX -114200.	MYX -0.	T 26900.
	NO. IT. 2	QXP(N) -0.00000	QYP(N) -0.	
IX(NA) 4.50691E 01	IY(NA) 3.06472E 02	IXY(NA) 4.89785E 00	XBAR 2.93598E-01	YBAR 2.05533E 00
IX(NA)F 4.50691E 01	IY(NA)F 3.06472E 02	IXY(NA)F 4.89785E 00	XBARF 2.93598E-01	YBARF 2.05533E 00
AP(EFF) 1.15073E 00	AP(FULL) 2.30145E 00	A(TRUE) 5.53005E 00	2A(CELLS) 8.27116E 02	
	THETA X (RADIAN) 6.35556E-06	THETA Y (RADIAN) 0.	THETA T (RADIAN) 3.33895E-05	
	S.C.(X) -2.59914E 00	S.C.(X/C) 5.47129E-01	S.C.(Y) -0.	

NET WEB AND INTERNAL CELL SHEAR FLOWS

WEB 1	76.6235
CELL 1	76.6235
WEB 2	-112.3459
CELL 2	188.9694
WEB 3	-34.1508
CELL 3	14.6668

JOB NO. 1012

BOX BEAM ANALYSIS
 MODEL XV-5A
 VERTICAL TAIL
 STATION 54.20

22 AUG 63

CONDITION LG-4

ITEM	WP(EFF)	F(P)	F(S)	QP(NET)
WEB 1				76.6235
1	1.3138	1489.84	845.12	74.1059
2	3.9393	2559.86	2559.86	68.1637
3	5.2433	4623.76	4623.76	55.2029
4	5.2271	6383.06	6383.06	37.3640
5	3.9115	7710.85	7710.85	21.5522
WEB 2				133.8981
6	2.6474	8197.07	7562.49	62.0183
7	4.0360	8433.10	8433.10	43.7947
8	5.3906	8321.37	8321.37	19.8080
9	4.0555	7371.99	7371.99	3.5139
10	1.3557	6618.09	5983.52	-19.4840
WEB 3				-19.4840
11	0.	-15718.92	-15084.35	26.0531
12	0.	-16691.06	-16691.06	26.0531
13	0.	-18076.92	-18076.92	26.0531
14	0.	-18625.14	-18625.14	26.0531
15	0.	-18607.35	-17972.78	169.2907
WEB 2				56.9448
16	0.	-18332.08	-18332.08	56.9448
17	0.	-17426.17	-17426.17	56.9448
18	0.	-16088.74	-16088.74	56.9448
19	0.	-14446.73	-14446.73	56.9448
20	0.	-13587.65	-12963.21	76.6235
WEB 1				-0.0000

JOB NO. 1012

BOX BEAM ANALYSIS
MODEL XV-5A
VERTICAL TAIL
STATION 67.80

22 AUG 63

SECTION INPUT DATA

WIDTH TOL.	R(STG)	R(PLATE)	W/T	G/IE6	
0.050	1.000	1.000	20.00	3.900	
C	X0/C	R(WEB)	2A(TE)	DS(TE)	
44.30	0.6000	1.000	0.	0.	
T(TE)	2A(LE)	DS(LE)	T(LE)		
0.	113.00	24.000	0.0310		
FP(MAX)	FP(MIN)	FS(MIN)	QP(MAX)		
45000.	-30000.	-45600.	500.		
WEB	XW(U)	YW(U)	XW(L)	YW(L)	TW
1	18.78	2.57	18.78	-2.57	0.0400
2	0.	4.60	0.	-4.60	0.0400
3	-14.58	3.85	-14.58	-3.85	0.0320

J

JOB NO. 1012

BOX BEAM ANALYSIS
 MODEL XV-5A
 VERTICAL TAIL
 STATION 67.80

22 AUG 63

SECTION INPUT DATA

ITEM	X(S)	Y(S)	A(S)	IXOS	IYOS	IXYOS	X(P)	Y(P)	T(P)	E/1E6
1	19.00	2.32	0.09	-0.	-0.	-0.	18.78	2.57	0.031	0.
2	16.43	2.95	0.	-0.	-0.	-0.	16.43	2.95	0.031	0.
3	11.73	3.58	0.	-0.	-0.	-0.	11.73	3.58	0.031	0.
4	7.03	4.10	0.	-0.	-0.	-0.	7.03	4.10	0.031	0.
5	2.33	4.48	0.	-0.	-0.	-0.	2.33	4.48	0.031	0.
6	0.	4.35	0.46	-0.	-0.	-0.	0.	4.60	0.031	0.
7	-2.43	4.65	0.	-0.	-0.	-0.	-2.43	4.65	0.031	0.
8	-7.29	4.53	0.	-0.	-0.	-0.	-7.29	4.53	0.031	0.
9	-12.15	4.14	0.	-0.	-0.	-0.	-12.15	4.14	0.031	0.
10	-14.58	3.60	0.17	-0.	-0.	-0.	-14.58	3.85	0.031	0.
11	-14.58	-3.60	0.17	-0.	-0.	-0.	-14.58	-3.85	0.031	0.
12	-12.15	-4.14	0.	-0.	-0.	-0.	-12.15	-4.14	0.031	0.
13	-7.29	-4.53	0.	-0.	-0.	-0.	-7.29	-4.53	0.031	0.
14	-2.43	-4.65	0.	-0.	-0.	-0.	-2.43	-4.65	0.031	0.
15	0.	-4.35	0.46	-0.	-0.	-0.	0.	-4.60	0.031	0.
16	2.33	-4.48	0.	-0.	-0.	-0.	2.33	-4.48	0.031	0.
17	7.03	-4.10	0.	-0.	-0.	-0.	7.03	-4.10	0.031	0.
18	11.73	-3.58	0.	-0.	-0.	-0.	11.73	-3.58	0.031	0.
19	16.43	-2.95	0.	-0.	-0.	-0.	16.43	-2.95	0.031	0.
20	19.00	-2.32	0.09	-0.	-0.	-0.	18.78	-2.57	0.031	0.

JOB NO. 1012

BOX BEAM ANALYSIS
MODEL XV-5A
VERTICAL TAIL
STATION 67.80

22 AUG 63

CONDITION AF-10

SX -1222.	SY -0.	MXX -33600.	MYX -0.	T 27400.
	NO. IT. 2	QXP(N) 0.00000	QYP(N) -0.	
IX(NA) 3.32853E 01	IY(NA) 2.39140E 02	IXY(NA) 3.91984E 00	XBAR 1.79449E-01	YBAR 1.69431E 00
IX(NA)F 3.32853E 01	IY(NA)F 2.39140E 02	IXY(NA)F 3.91984E 00	XBARF 1.79449E-01	YBARF 1.69431E 00
AP(EFF) 1.03895E 00	AP(FULL) 2.07790E 00	A(TRUE) 5.09190E 00	2A(CELLS) 6.52771E 02	
	THETA X (RADIAN) 5.16260E-06	THETA Y (RADIAN) 0.	THETA T (RADIAN) 4.90875E-05	
	S.C.(X) -2.35818E 00	S.C.(X/C) 5.46768E-01	S.C.(Y) -0.	

NET WEB AND INTERNAL CELL SHEAR FLOWS

WEB	1	72.8241
CELL	1	72.8241
WEB	2	-83.5967
CELL	2	156.4208
WEB	3	-18.0381
CELL	3	25.2748

JOB NO. 1012

BOX BEAM ANALYSIS
 MODEL XV-5A
 VERTICAL TAIL
 STATION 67.80

22 AUG 63

CONDITION AF-10

ITEM	WP(EFF)	F(P)	F(S)	QP(NET)
WEB 1				72.8241
1	1.1903	577.31	320.81	70.8806
2	3.5613	1000.61	1000.61	66.4841
3	4.7354	1715.71	1715.71	57.3267
4	4.7220	2319.56	2319.56	44.9799
5	3.5242	2781.81	2781.81	34.1357
WEB 2				117.7324
6	2.3818	2941.81	2688.96	64.6480
7	3.6460	3032.67	3032.67	52.1646
8	4.8686	2991.87	2991.87	35.7429
9	3.6614	2677.99	2677.99	24.4940
10	1.2236	2424.97	2172.12	7.2367
WEB 3				7.2367
11	0.	-5362.87	-5110.02	39.7598
12	0.	-5696.46	-5696.46	39.7598
13	0.	-6171.48	-6171.48	39.7598
14	0.	-6373.42	-6373.42	39.7598
15	0.	-6363.14	-6110.29	142.4279
WEB 2				58.8312
16	0.	-6280.40	-6280.40	58.8312
17	0.	-5973.98	-5973.98	58.8312
18	0.	-5525.97	-5525.97	58.8312
19	0.	-4966.70	-4966.70	58.8312
20	0.	-4621.32	-4372.12	72.8241
WEB 1				0.0000

JOB NO. 1012

BOX BEAM ANALYSIS
MODEL XV-5A
VERTICAL TAIL
STATION 67.80

22 AUG 63

CONDITION LG-4

SX -1053.	SY -0.	MXX -98900.	MYX -0.	T 35900.
	NO. IT. 2	QXP(N) 0.00000	QYP(N) -0.	
IX(NA) 3.32853E 01	IY(NA) 2.39140E 02	IXY(NA) 3.91984E 00	XBAR 1.79449E-01	YBAR 1.69431E 00
IX(NA)F 3.32853E 01	IY(NA)F 2.39140E 02	IXY(NA)F 3.91984E 00	XBARF 1.79449E-01	YBARF 1.69431E 00
AP(EFF) 1.03895E 00	AP(FULL) 2.07790E 00	A(TRUE) 5.09190E 00	2A(CELLS) 6.52771E 02	
	THETA X (RADIAN) 4.44862E-06	THETA Y (RADIAN) 0.	THETA T (RADIAN) 6.43154E-05	
	S.C.(X) -2.35818E 00	S.C.(X/C) 5.46768E-01	S.C.(Y) -0.	

NET WEB AND INTERNAL CELL SHEAR FLOWS

WEB	1	81.2025
CELL	1	81.2025
WEB	2	-74.6964
CELL	2	155.8989
WEB	3	-8.9993
CELL	3	36.3460

JOB NO. 1012

BOX BEAM ANALYSIS
 MODEL XV-5A
 VERTICAL TAIL
 STATION 67.80

22 AUG 63

CONDITION LG-4

ITEM	WP(EFF)	F(P)	F(S)	QP(NET)
WEB 1				81.2025
1	1.1903	1699.29	944.30	79.5278
2	3.5613	2945.24	2945.24	75.7393
3	4.7354	5050.11	5050.11	67.8484
4	4.7220	6827.52	6827.52	57.2091
5	3.5242	8188.14	8188.14	47.8647
WEB 2				122.5611
6	2.3818	8659.08	7914.82	76.8181
7	3.6460	8926.51	8926.51	66.0612
8	4.8686	8806.43	8806.43	51.9106
9	3.6614	7882.54	7882.54	42.2173
10	1.2236	7137.78	6393.52	27.3467
WEB 3				27.3467
11	0.	-15785.35	-15041.09	55.3720
12	0.	-16767.27	-16767.27	55.3720
13	0.	-18165.46	-18165.46	55.3720
14	0.	-18759.87	-18759.87	55.3720
15	0.	-18729.59	-17985.33	143.8413
WEB 2				69.1448
16	0.	-18486.05	-18486.05	69.1448
17	0.	-17584.13	-17584.13	69.1448
18	0.	-16265.42	-16265.42	69.1448
19	0.	-14619.24	-14619.24	69.1448
20	0.	-13602.64	-12869.12	81.2025
WEB 1				0.0000

VERTICAL STABILIZER

SUMMARY OF SPAR CAP MARGINS OF SAFETY

CRITICAL COND: LG-4

STA.	FRONT SPAR			CENTER SPAR			REAR SPAR		
	f_c	F_c	M.S.	f_c	F_c	M.S.	f_c	F_c	M.S.
13.40	23530	42500	+0.81	25147	45600	+0.82	13651	32400	+1.37
27.00	19691	42500	+1.16	21039	45600	+1.16	13530	35600	+1.63
40.6	16841	42500	+1.52	18609	45600	+1.45	11946	35600	+1.98
54.2	15084	42500	+1.82	17973	45600	+1.54	12963	28800	+1.22
67.80	15041	42500	+1.83	17985	45600	+1.54	12869	28800	+1.24

VERTICAL STABILIZER

SPAR SHEAR ANALYSIS

FRONT SPAR

CRITICAL $q = 90 \text{ #/in} @ \text{ V.S. STA. 27.00, COND. AF-10}$

.032 7075-T6 WEB

$$A_s = .053 \text{ (.7} \times \text{.7} \times \text{.040 ANGLE)}$$

$$\frac{A_s}{b t} = \frac{.053}{7 \times .04} = .19$$

$$\text{ALLOW. } q = .76 \times 680 = 516 \text{ #/in.}$$

(REF. BOEING DESIGN MANUAL, P. 15.62209)

M.S. HIGH

CENTER SPAR

CRITICAL $q = 485 \text{ #/in.} @ \text{ V.S. STA. 13.4, COND. LG-4}$

.040 7075-T6 WEB

$$A_s = .114 \text{ (.70} \times \text{.88} \times \text{.040 } \& \text{ .70} \times \text{.75} \times \text{.040 ANGLES)}$$

$$\frac{A_s}{b t} = \frac{.114}{6.9 \times .04} = .41$$

$$\text{ALLOW. } q = .94 \times 920 = 864 \text{ #/in.}$$

$$\text{M.S.} = \frac{864}{485} - 1 = \underline{\underline{+.78}}$$

VERTICAL STABILIZER

REAR SPAR

CRITICAL $q = 118 \text{ #/in}$ @ V.S. STA. 13.4, COND. AF-10

.040 7075-T6 WEB

$A_s = .055$ (.70 x .75 x .04 ANGLE)

$$\frac{A_s}{b t} = \frac{.055}{6.8 \times .04} = .2$$

ALLOW. $q = .76 \times 920 = 699 \text{ #/in.}$

M.S. HIGH

SUBJECT: _____
SECTION: _____
ENGINEER: _____
CHECKER: _____

VERTICAL STABILIZER

MODEL: _____
PAGE: _____
REPORT: _____
DATE: _____

PIVOT FITTING (DWG. 143 T 008)

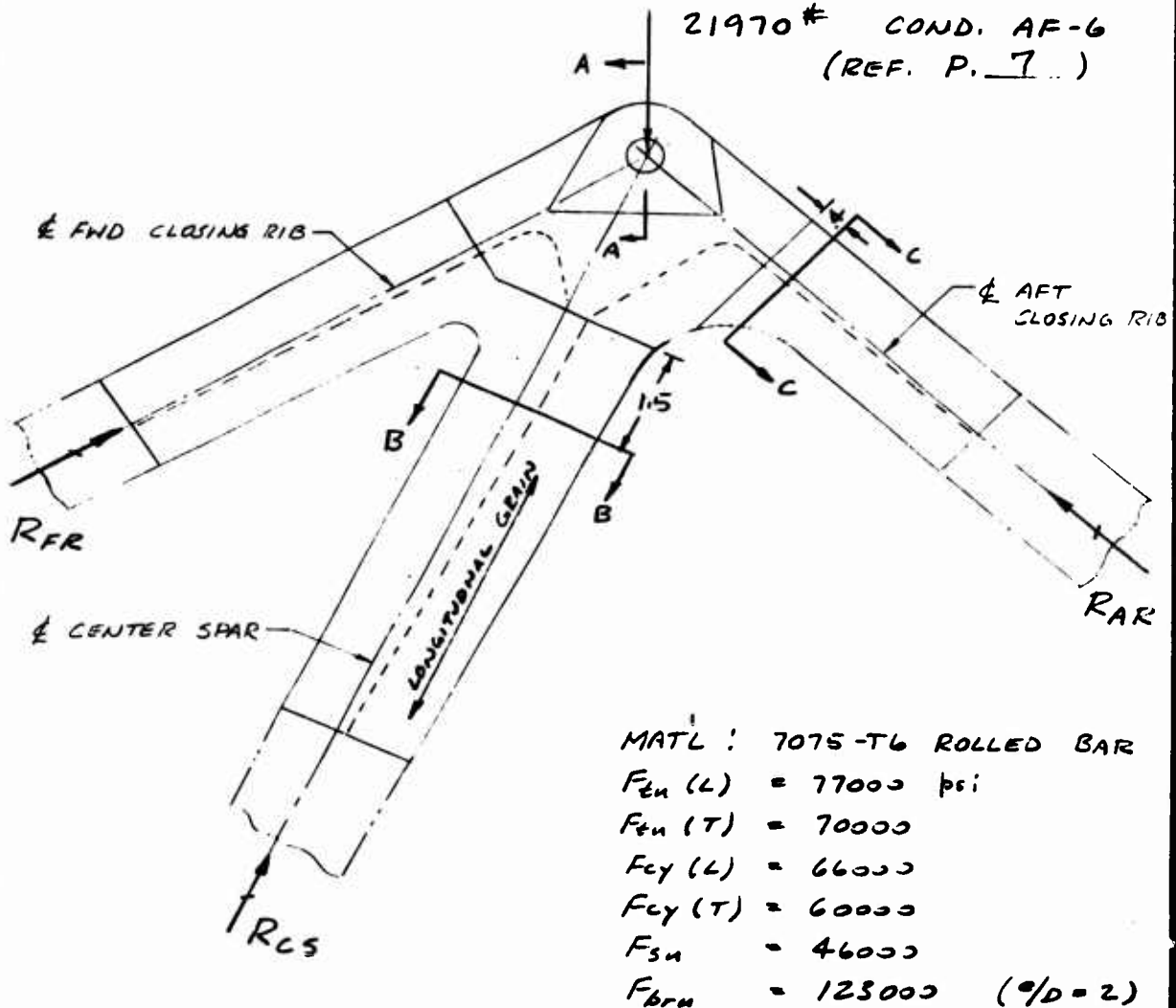

VERTICAL STABILIZER

PIVOT FITTING (DWG. 143T008)

THE DISTRIBUTION OF PIVOT LOAD TO THE FWD & ART RIB FLANGES AND CENTER SPAR IS REDUNDANT. THE FOLLOWING DISTRIBUTION WAS DETERMINED BY A REDUNDANT ANALYSIS OF THE STRUCTURE ABOVE V.S. STA. 72.05:

$$R_{FR} = 1530 \text{ *}$$

$$R_{CS} = 15200 \text{ *}$$

$$R_{AR} = 10490 \text{ *}$$

PIN

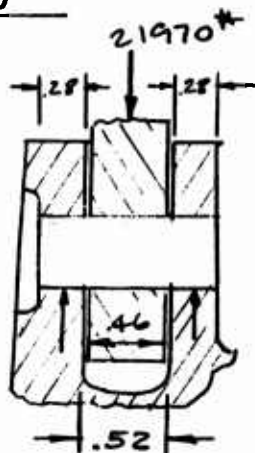

NAS 1138 SCREW (1/2" DIA.)

ALLOW. DBL SHEAR = 37300 *

$$M.S. = \frac{37300}{21970} - 1 = \underline{+1.70}$$

$$B.M. = \left(\frac{.28}{2} + \frac{.46}{4} + .03 \right) \frac{21970}{2}$$

$$= 3130 \text{ * *}$$

$$f_b = \frac{3130 \times .25}{.003069} = 255000 \text{ psi}$$

$$F_b = 1.7 F_{tu} = 1.7 \times 160000$$

$$= 272000 \text{ psi}$$

$$M.S. = \frac{272000}{255000} - 1 = \underline{+1.07}$$

$$f_{br} = \frac{21970}{2 \times .28 \times .5} = 79000 \text{ psi}$$

$$M.S. = \frac{123000}{79000} - 1 = \underline{+1.56}$$

VERTICAL STABILIZER

PIVOT FITTING

CENTER SPAR LEG

ATTACHMENT TO SPAR CAP :

18 BC 5 IN DBL SHEAR & 9 CX 6 IN DBL SHEAR

$$\text{TOTAL ALLOW. LOAD} = 2(18 \times 556 + 9 \times 1180) = 41200 \#$$

$$\text{M.S.} = \frac{41200}{15200} - 1 = \underline{\underline{+1.71}}$$

SECT. B-B :

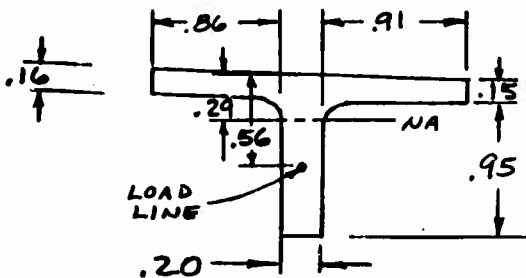

$$A = .509 \quad I = .0701$$

LOAD IS TRANSFERED TO SPAR BY 4 BC 5 & 2 CX 6

$$P_{B-B} = \frac{7}{9} \times 15200 = 11800 \#$$

$$\text{B.M.} = 11800 (.56 - .29) = 3190 \# \text{in}$$

$$f_c = -\frac{11800}{.509} - \frac{3190 \times .81}{.0701}$$

$$= -23200 - 36800 = 60000 \text{ psi}$$

$$F_{cy} = 66000 \text{ psi}$$

$$\text{M.S.} = \frac{66000}{60000} - 1 = \underline{\underline{+1.10}}$$

VERTICAL STABILIZER

PIVOT FITTING

AFT CLOSING RIB LEG

ATTACHMENT TO RIB FLANGE: (REF. DWG 143T010)

4 BB 5, 5 BLS & 5 BJS ALL IN DBL SHEAR

$$\text{TOTAL ALLOW. LOAD} = 2(5 \times 556 + 9 \times 596) = 16280 \#$$

$$\text{M.S.} = \frac{16280}{10490} - 1 = \underline{\underline{+.55}}$$

SECT. C-C :

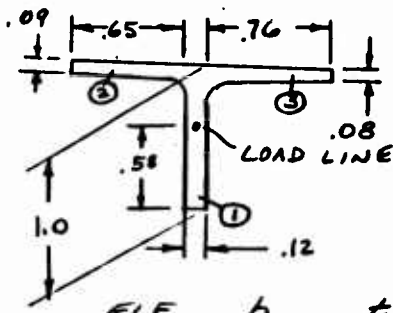

$$A = .243 \quad \bar{y} = .269$$

FIND CRIPPLING ALLOWABLE BY CONVAIR METHOD (REF. CONVAIR STRUCTURES MANUAL P. 2.241 & STRESS MEMO # 20). ASSUME $F_{cy} = 60000$ psi, TRANSVERSE VALUE

ELE	b	t	b/t	$\frac{1}{\sqrt{k}}$	$\frac{b}{t\sqrt{k}}$	A	F_{cn}	P_{cn}
1	.91	.12	7.57	1	7.57	.109	64000	7520
2	.65	.09	7.2	1.25	9	.0585	60000	3510
3	.76	.085	8.95	1.25	11.2	.0646	52000	3360
Σ						.2321		14390

$$F_{cr} = \frac{\Sigma P_{cn}}{\Sigma A} = \frac{14390}{.2321} = 62000 \text{ psi}$$

FIND ALLOWABLE PLASTIC BENDING MOMENT ASSUMING SKIN LEGS 2 & 3 ARE IN TENSION.

$$\text{LOAD IN ELE ①} = 64000 \times .91 \times .12 = 7520 \#$$

$$\text{AREA OF SKIN LEGS} = .243 - .91 \times .12 = .134$$

VERTICAL STABILIZER

PIVOT FITTING

SECT. C-C (CONT.) !

$$\text{TENSION STRESS} = 7520 / .134 = 56000 \text{ psi} \quad \text{O.K.}$$

$$\text{ALLOW. B.M.} = 7520 \left(\frac{.91}{2} + \frac{.09}{2} \right) = 3760 \text{ " *}$$

LOAD @ SECT. C-C IS RELIEVED BY 3 RIVETS

$$\text{ALLOW} = 2(556 + 2 \times 596) = 3300 \text{ *}$$

$$\text{LOAD @ SECT. C-C} = \frac{16290 - 3300}{16290} \times 10490 = 8350 \text{ *}$$

$$\text{B.M.} = 8350 (.731 - .58) = 1260 \text{ * *}$$

$$f_c = \frac{8350}{.243} = 34400 \text{ psi}$$

$$R_c = \frac{34400}{62000} = .555$$

$$R_{BM} = \frac{1260}{3760} = .335$$

$$R_c + R_{BM} = 1$$

$$\text{M.S.} = \frac{1}{.555 + .335} - 1 = \underline{\underline{+ .12}}$$

SUBJECT: _____
 SECTION: _____
 ENGINEER: _____
 CHECKER: _____

VERTICAL STABILIZER

MODEL: _____
 PAGE: _____
 REPORT: _____
 DATE: _____

HORIZ. STAB. ACTUATOR SUPPORT FITTING (DWG. 145T006)
 (REF. PG. 7 FOR LOAD)

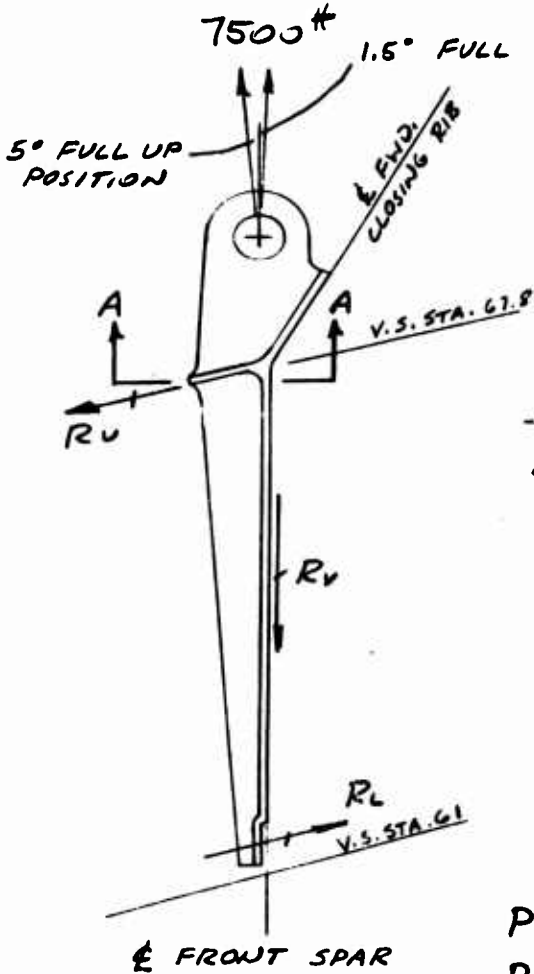

MAT'L : 7075 - T6
 ROLLED BAR

$$F_{tu}(L) = 77000 \text{ psi}$$

$$F_{tu}(T) = 70000 \text{ psi}$$

LUG

ANALYZED BY MELCON-HOBLIT
 METHOD

$$a = .65 \quad D = .6875 \quad t = .32$$

$$W/D = 1.3 / .6875 = 1.89$$

$$a/D = .65 / .6875 = .945$$

$$D/t = .6875 / .32 = 2.15$$

$$A_t = (1.3 - .6875) \cdot .32 = .196$$

$$A_{br} = .6875 \times .32 = .22$$

$$P_{tu} = .97 \times .196 \times 77000 = 14600 \#$$

$$P_{bru} = .78 \times .22 \times 70000 = 12000 \#$$

$$M.S. = \frac{12000}{7500} - 1 = + \underline{\underline{.60}}$$

HORIZ. STAB. ACTUATOR SPT. FTG.

SECT. A-A

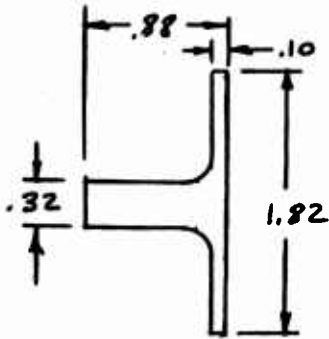

$$A = .432$$

$$I = .0331$$

$$\bar{x} = .304$$

$$\text{ECCENTRICITY} = .304$$

$$B.M. = 7500 \times .304 = 2280 \text{ "}\#$$

$$f_t = \frac{7500}{.432} + \frac{2280 \times .304}{.0331}$$

$$= 17400 + 20900 = 38300 \text{ psi}$$

$$F_t = .75 F_{tu} = .75 \times 77000 = 57750 \text{ psi (ALLOWABLE STRESS FOR GROSS AREA)}$$

$$M.S. = \frac{57750}{38300} - 1 = \underline{\underline{+.51}}$$

ATTACHMENT TO FRONT SPAR

4 CX 6 AND 14 BJ 5 RIVETS BEARING ON
.032 WEBS

$$\text{ALLOWABLE} = 4 \times 146000 \times .032 \times .188 + 14 \times 596 \times .932 = 11300 \text{ }\#$$

$$M.S. = \frac{11300}{7500} - 1 = \underline{\underline{+.51}}$$

V. RUDDER

LOADING

MAX. LOADING OCCURS IN COND. AF-9 OR AF-10, WHICH ARE ABRUPT RUDDER DEFLECTION CONDITIONS AT MACH NO. .397 AND $q = 234$ psf.

TOTAL ULT. LOAD = 1935 #

ULT. RUDDER HINGE MOMENT = 3330 #"

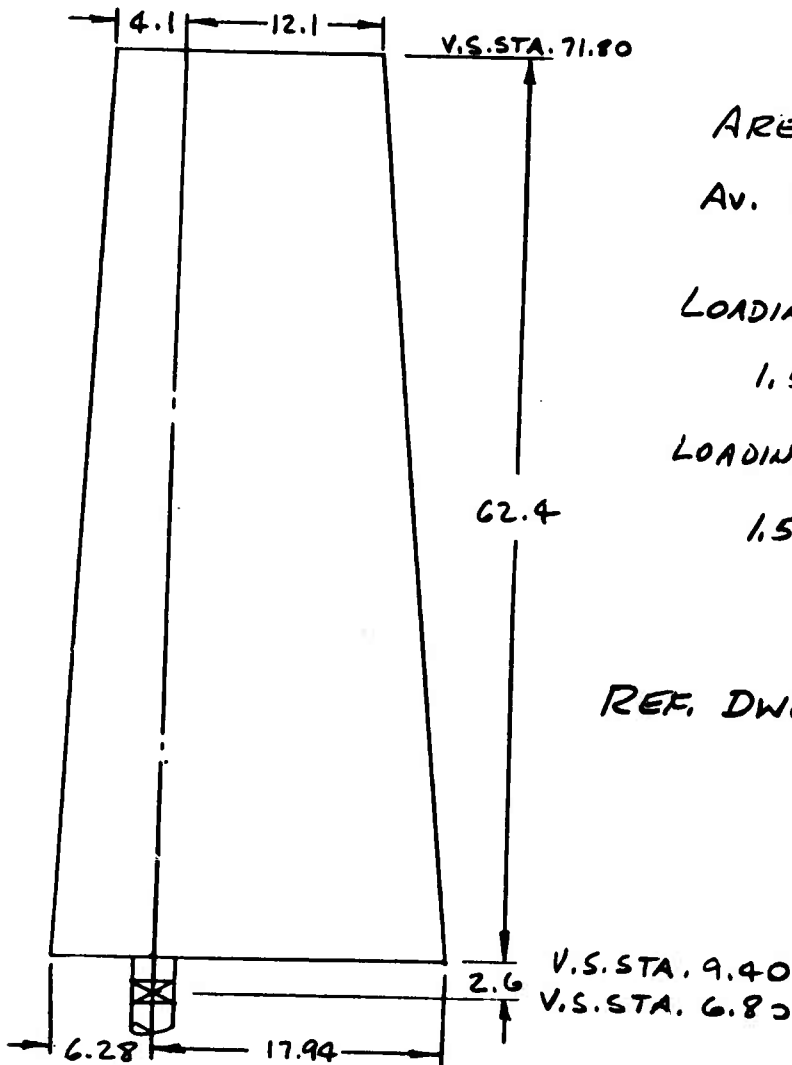

$$\text{AREA} = 1260 \text{ IN}^2$$

$$\text{AV. } p = \frac{1935}{1260} = 1.533 \text{ psi}$$

LOADING @ UPR. END, $w_u =$

$$1.533 \times 16.2 = 24.85 \text{ #/IN.}$$

LOADING @ LWR. END, $w_l =$

$$1.533 \times 24.22 = 37.2 \text{ #/IN.}$$

REF. DWG. 143 T 050

RUDDER

HINGE LOADS

C.P. IS 28.15" ABOVE LOWER EDGE

$$R_U = \frac{30.75 \times 1935}{65} = 915 \#$$

$$R_L = 1935 - 915 = 1020 \#$$

CABLE LOAD APPLIED TO TENSION REGULATOR =
HINGE MOMENT/RADIUS = $3330/5.5 = 605 \#$

THIS LOAD IS ASSUMED TO BE REACTED AT
LOWER HINGE FITTING.

SHEAR & BENDING MOMENT

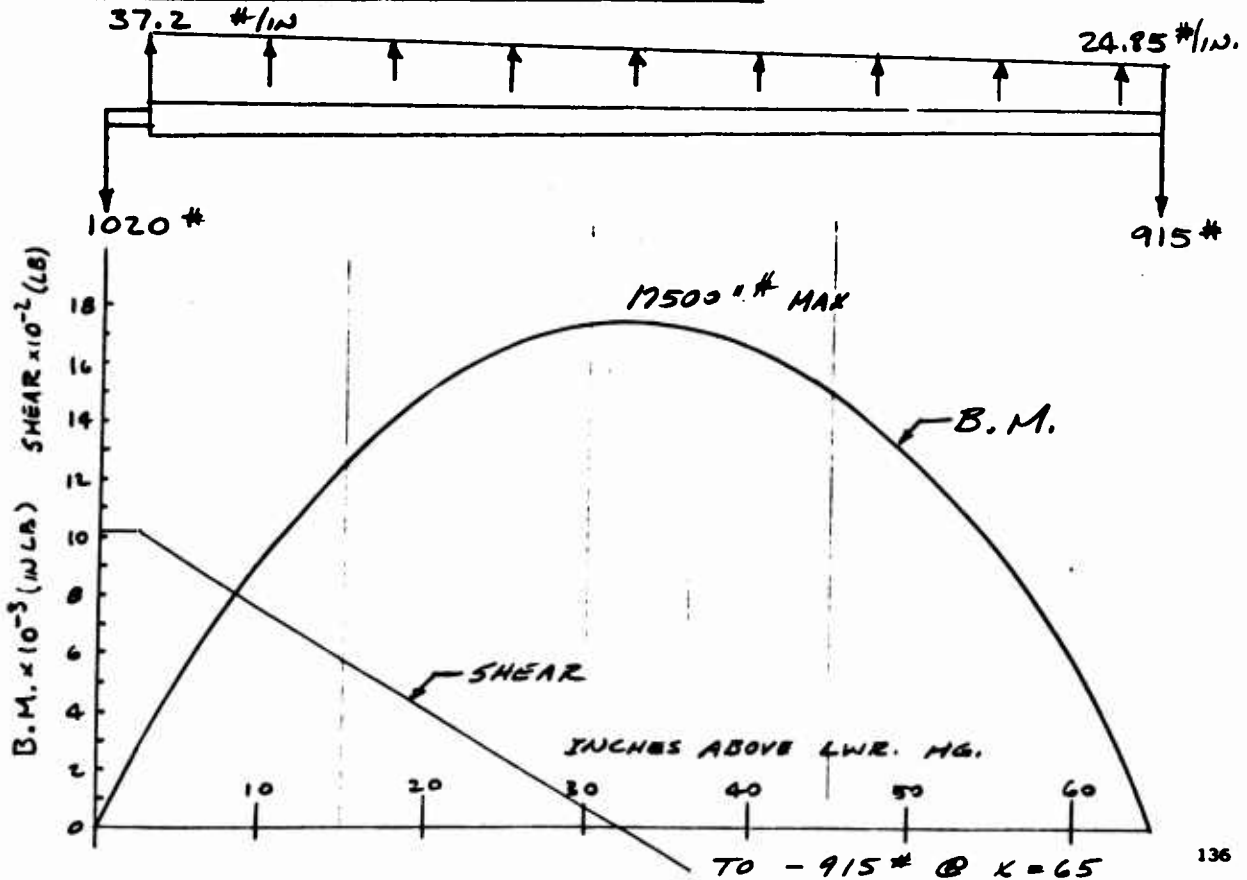

RUDDER

BENDING ANALYSIS - MAX. B.M. @ V.S. STA. 39.3

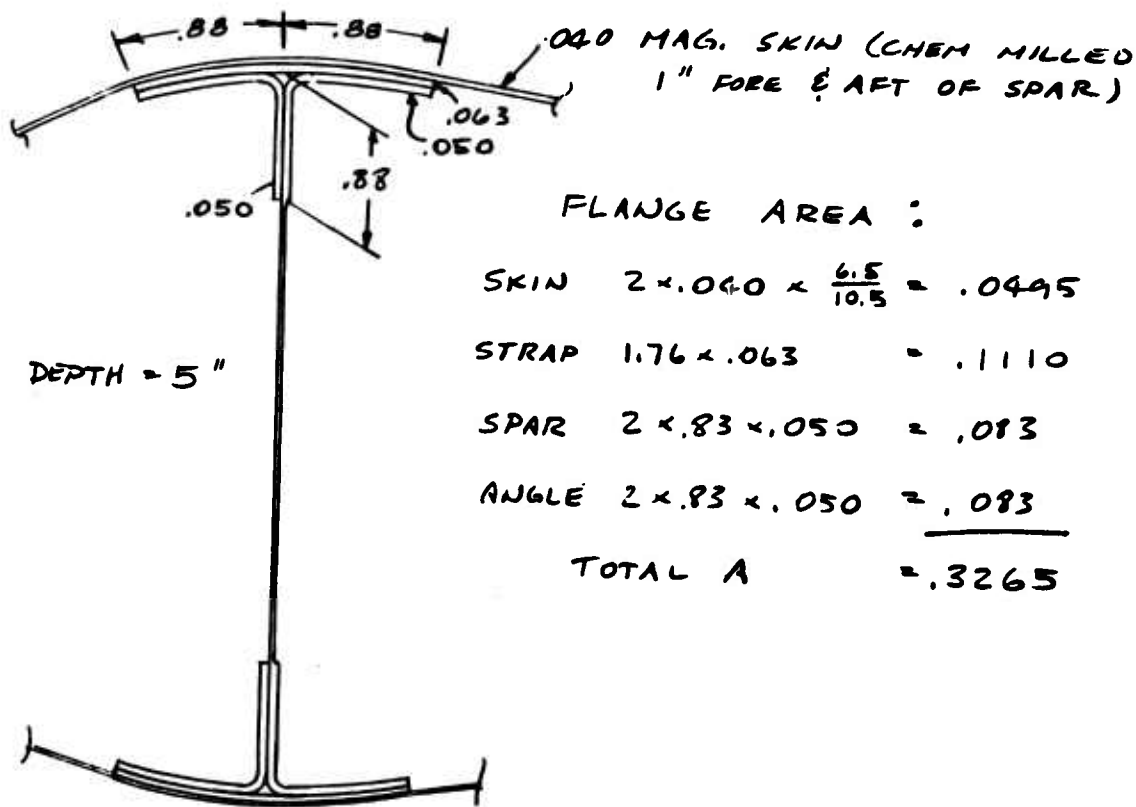

FLANGE AREA :

$$\text{SKIN } 2 \times .040 \times \frac{6.5}{10.5} = .0445$$

$$\text{STRAP } 1.76 \times .063 = .1110$$

$$\text{SPAR } 2 \times .83 \times .050 = .083$$

$$\text{ANGLE } 2 \times .83 \times .050 = .083$$

$$\text{TOTAL A} = .3265$$

$$\text{FLANGE LOAD} = M/h = \frac{17500}{4.4} = 3980 \#$$

$$f_c = 3980 / .3265 = 12200 \text{ psi}$$

M.S. AMPLE *

* LARGE MARGIN OF SAFETY RESULTS FROM DESIGN BEING BASED ON STIFFNESS REQUIREMENT TO PREVENT FLUTTER.

RUDDER

SHEAR ANALYSIS

CRITICAL SECTION @ LOWER END.

NEGLECT NOSE BOX.

$$T = 3330 \text{ " *}$$

$$S = 1020 \text{ *}$$

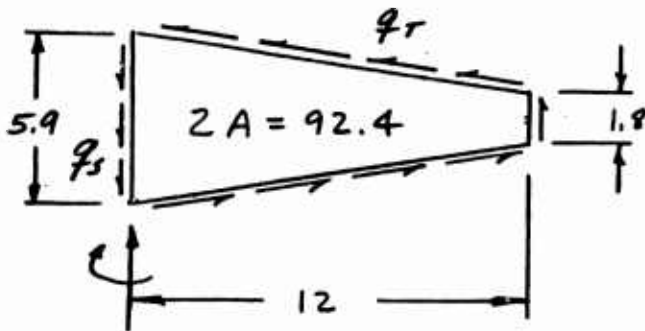

$$q_T = 3330 / 92.4 = 36 \text{ * / IN.}$$

$$q_s = \frac{1020}{5.3} + 36 = 228 \text{ * / IN.}$$

.020 MAG SKIN

$$f_s = 36 / .02 = 1800 \text{ psi}$$

M.S. AMPLE

.032 7075-T6 SPAR WEB

$$f_s = 228 / .032 = 7120 \text{ psi}$$

M.S. AMPLE