

AD646512



**PROCEEDINGS
OF THE
2ND ANNUAL CONFERENCE
ON
ATMOSPHERIC CONTAMINATION
IN
CONFINED SPACES
4 and 5 MAY 1966**

BEST AVAILABLE COPY

Distribution of this document
is unlimited

20040831048

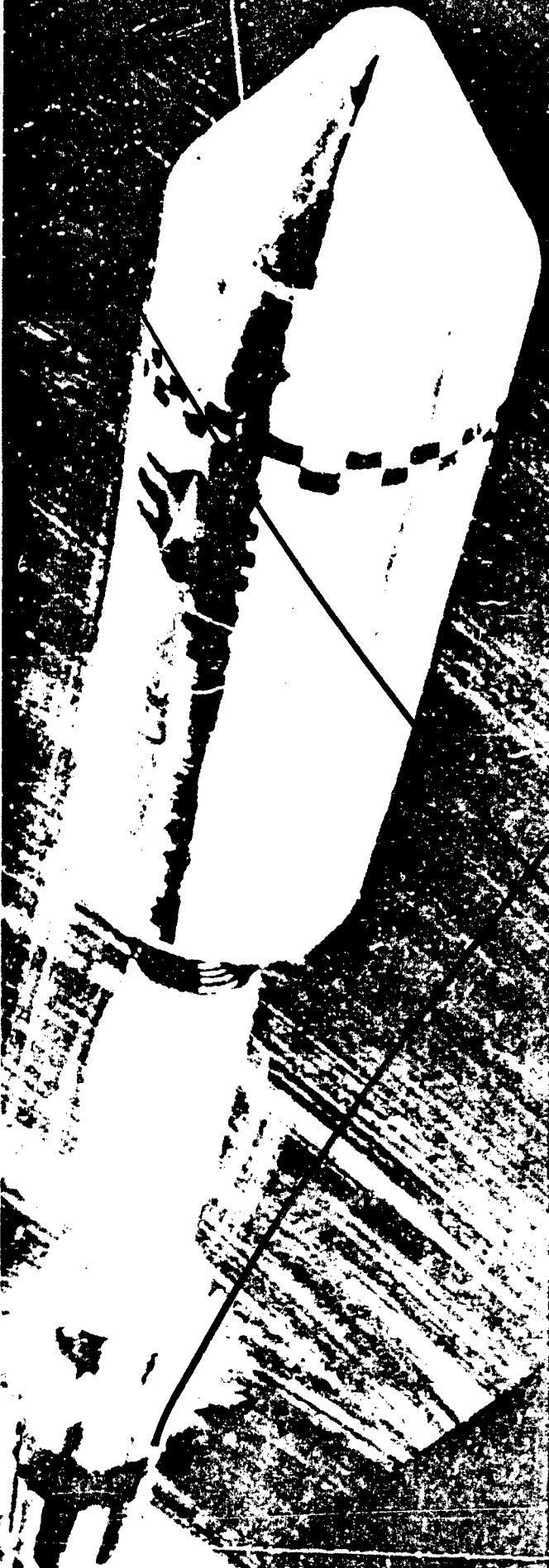

**PROCEEDINGS
OF THE
2ND ANNUAL CONFERENCE
ON
ATMOSPHERIC
CONTAMINATION
IN
CONFINED SPACES
4 and 5 MAY 1966**

DECEMBER 1966

Distribution of this document
is unlimited.

AEROSPACE MEDICAL RESEARCH
LABORATORIES
AEROSPACE MEDICAL DIVISION
AIR FORCE SYSTEMS COMMAND
WRIGHT-PATTERSON AIR FORCE BASE, OHIO

FOREWORD

The 2nd Annual Conference on Atmospheric Contamination in Confined Spaces was held in Dayton, Ohio on 4 and 5 May 1966. Sponsor was the Aerospace Medical Research Laboratories, Aerospace Medical Division, Air Force Systems Command. Arrangements were made by the Toxic Hazards Research Unit of Aerojet-General Corporation under the terms of Contract AF 33(657)-11305. The Toxic Hazards Research Unit is located at the Toxic Hazards Division, Biomedical Laboratory, Wright-Patterson Air Force Base, Ohio. Dr. Anthony A. Thomas, Chief, Toxic Hazards Division, and Dr. Kenneth C. Back, Chief, Toxicology Branch, served as Co-Chairmen. Capt. John A. Jurgiel served as Conference Coordinator for the Air Force, and Mr. Russell W. Kuehl for Aerojet-General Corporation.

Acknowledgment is made on behalf of the Aerospace Medical Research Laboratories to Col. George E. Schafer, Deputy Commander, Aerospace Medical Division, Brooks Air Force Base, Texas, for his introductory remarks and support, to the session Chairmen and speakers, to the panel members of the Open Forum and all those who actively participated in the discussion. Special thanks are due to T/Sgt. James G. King III, A1C William M. Macek, M/Sgt. John L. Naylor, and A2C James P. Valentine, MRBT, Toxic Hazards Division, and to Mrs. Marilyn Collins, Mrs. Lois Doncaster, and Mr. George Wishart of Aerojet-General Corporation.

ABSTRACT

✓ This report is a complete compilation of the papers presented and the Proceedings of the 2nd Annual Conference on Atmospheric Contamination in Confined Spaces, sponsored by the Aerospace Medical Research Laboratories and held in Dayton, Ohio on 4 and 5 May 1966. Major technical areas discussed by the invited speakers, members of the Open Forum, and Conference attendees included toxicology of space cabin materials, comparative toxicology and pathology of oxygen, and the effects of oxygen on contaminant toxicity. ✓

TABLE OF CONTENTS

	Page
INTRODUCTION	1
WELCOMING REMARKS.	2
INTRODUCTORY REMARKS	4
SESSION I - TOXICOLOGY OF SPACE CABIN MATERIALS	7
• PARTS AND MATERIALS DATA RETRIEVAL PROGRAM RELATIVE TO MATERIALS SELECTION IN TOXICOLOGY. Elliott S. Harris	9
• GAS-OFF STUDIES OF CABIN MATERIALS. John V. Pustinger	14
• TOXICOLOGICAL SCREENING OF SPACE CABIN MATERIAL B. Dwight Culver	24
• CONTAMINANT STUDIES IN CLOSED SYSTEMS AT THE SCHOOL OF AEROSPACE MEDICINE James P. Conkle	31
• A DANGEROUS CLOSED ATMOSPHERE TOXICANT, ITS SOURCE AND IDENTITY Raymond A. Saunders	53
SESSION II - COMPARATIVE TOXICOLOGY AND PATHOLOGY OF OXYGEN	61
• OXYGEN TOXICITY AT NEAR-AMBIENT PRESSURES. James D. MacEwen	65
• PATHOLOGICAL EVALUATION OF OXYGEN TOXICITY AT NEAR-AMBIENT PRESSURES Farrel R. Robinson	73
• TOXICITY STUDIES ON ANIMALS EXPOSED CONTINUOUSLY FOR PERIODS UP TO 235 DAYS TO A 5 PSIA 100% OXYGEN ATMOSPHERE Kenneth C. Back	80
• PATHOLOGY OF ANIMALS EXPOSED TO A PURE OXYGEN ATMOSPHERE AT REDUCED PRESSURE FOR PROLONGED PERIODS David T. Harper	88

TABLE OF CONTENTS (CONT'D)

	Page
• PATHOLOGY OF ANIMALS EXPOSED FOR 235 DAYS TO A 5 PSIA 100% OXYGEN ATMOSPHERE O. E. Hagebusch	103
• ELECTRON MICROSCOPIC INVESTIGATIONS OF OXYGEN EFFECTS ON LUNG TISSUE Gonzague Kistler	108
• ELECTRON MICROSCOPIC INVESTIGATIONS OF OXYGEN EFFECTS ON LIVER TISSUE. Fenton Schaffner	162
• ELECTRON MICROSCOPIC INVESTIGATIONS OF OXYGEN EFFECTS ON KIDNEY TISSUE Willy Mautner	170
• CELLULAR BIOCHEMISTRY OF OXYGEN TOXICITY. Willis H. Riesen	178
• HEMATCLOGIC EFFECTS OF INCREASED OXYGEN TENSIONS Harold P. Kaplan	200
• PSYCHOPHARMACOLOGICAL EVALUATION OF PRIMATES EXPOSED TO 5 PSIA 100% OXYGEN ATMOSPHERE Thomas L. Wolfle	223
SESSION III - OXYGEN EFFECT ON CONTAMINANT TOXICITY	237
• COMPARATIVE TOXICITY STUDIES ON ANIMALS EXPOSED CONTINUOUSLY FOR PERIODS UP TO 90 DAYS TO NO ₂ , O ₃ , AND CCl ₄ IN AMBIENT AIR VS. 5 PSIA 100% OXYGEN ATMOSPHERE Robert P. Geckler	238
• PATHOLOGICAL EFFECTS OF EXPOSURE TO PULMONARY IRRITANTS AT AMBIENT AIR VS. 5 PSIA 100% OXYGEN ATMOSPHERE FOR PERIODS UP TO 90 DAYS R. L. Patrick	260
• COMPARATIVE PATHOLOGY OF ANIMALS EXPOSED TO CARBON TETRACHLORIDE AT AMBIENT AIR VS. 5 PSIA 100% OXYGEN ATMOSPHERE David T. Harper	265

TABLE OF CONTENTS (CONT'D)

	Page
SESSION IV - SINGLE VS. MIXED GAS ATMOSPHERES	279
• RESUME OF MANNED EXPERIMENTS.	281
Lester Krasnogor	
• EFFECT OF A MIXED GAS ATMOSPHERE AT 5 PSIA ON THE TOXICITY OF NO ₂ AND O ₃ IN ANIMALS	290
James D. MacEwen	
OPEN FORUM	297

PRINCIPAL SPEAKERS AND PARTICIPANTS

BACK, Kenneth C., Dr.
Toxicology Branch
Toxic Hazards Division
Aerospace Medical Research
Laboratories
Wright-Patterson Air Force Base, Ohio

CONKLE, James P., Mr.
Environmental Systems Branch
USAF School of Aerospace Medicine
Brooks Air Force Base, Texas

COULSTON, Frederick, Dr.
Albany Medical College
Institute of Experimental Pathology
and Toxicology
Albany, New York

CULVER, B. Dwight, Dr.
Life Support Systems
Aerojet-General Corporation
Azusa, California

FAIRCHILD, Edward J. II, Dr.
Division of Occupational Health
Department of Health, Education,
and Welfare
Cincinnati, Ohio

GECKLER, Robert P., Dr.
Toxic Hazards Research Unit
Aerojet-General Corporation
Wright-Patterson Air Force Base, Ohio

GROSS, Paul, Dr.
Industrial Hygiene Foundation of
America, Inc.
Mellon Institute
Pittsburgh, Pennsylvania

HAGESUSCH, O. E., Dr.
Laboratory for Experimental Biology
St. Louis, Missouri

HARPER, David T. Jr., Capt., USAF
Toxic Hazards Division
Aerospace Medical Research
Laboratories
Wright-Patterson Air Force Base, Ohio

HARRIS, Elliott S., Dr.
Manned Spacecraft Center
National Aeronautics and Space
Administration
Houston, Texas

KAPLAN, Harold P., Capt., USAF
Toxic Hazards Division
Aerospace Medical Research
Laboratories
Wright-Patterson Air Force Base, Ohio

KISTLER, Gonzague, Dr.
Anatomisches Institut der Universitat
Zürich, Switzerland

KRASNOGOR, Lester, Capt., USAF
Environmental Systems Branch
USAF School of Aerospace Medicine
Brooks Air Force Base, Texas

MAC EWEN, James D., Dr.
Toxic Hazard's Research Unit
Aerojet-General Corporation
Wright-Patterson Air Force Base, Ohio

MAUTNER, Willy, Dr.
Department of Pathology
Mount Sinai Hospital
New York, New York

PATRICK, R. L., Dr.
Laboratory for Experimental Biology
St. Louis, Missouri

PUSTINGER, John V., Mr.
Monsanto Research Corporation
Dayton, Ohio

QUASHNOCK, Joseph M., Col., USAF
Commander
Aerospace Medical Research
Laboratories
Wright-Patterson Air Force Base, Ohio

RIESEN, Willis H., Dr.
Life Sciences Research
IIT Research Institute
Chicago, Illinois

PRINCIPAL SPEAKERS AND PARTICIPANTS (CONT'D)

ROBINSON, Farrel R., Maj., USAF
Toxic Hazards Division
Aerospace Medical Research
Laboratories
Wright-Patterson Air Force Base, Ohio

ROTH, Emanuel M., Dr.
Department of Aerospace Medicine
Lovelace Foundation for Medical
Education and Research
Albuquerque, New Mexico

SAUNDERS, Raymond A., Mr.
Physical Chemistry Branch
Naval Research Laboratory
Washington, D. C.

SCHAFER, George E., Col., USAF
Deputy Commander
Aerospace Medical Division
Brooks Air Force Base, Texas

SCHAFFNER, Fenton, Dr.
Department of Pathology
Mount Sinai Hospital
New York, New York

THOMAS, Anthony A., Dr.
Toxic Hazards Division
Aerospace Medical Research
Laboratories
Wright-Patterson Air Force Base, Ohio

VORWALD, Arthur J., Dr.
Department of Occupational and
Environmental Health
Wayne State University
Detroit, Michigan

WOLFLE, Thomas L., Capt., USAF
Comparative Psychology Division
Aeromedical Research Laboratory
Holloman Air Force Base, New Mexico

INTRODUCTION

The 2nd Annual Conference on Atmospheric Contamination in Confined Spaces addressed itself to the review of new research generated in the past year on the toxicology of basic cabin atmospheres and contaminants. The quality of this new information was excellent and the quantity overwhelming. Most of it was generated under the joint U. S. Air Force/NASA program at the Toxic Hazards Research Unit and at the various university and industrial contractors participating in this program. The scope of the effort is best illustrated by the productivity of the Toxic Hazards Research Unit which has performed without interruption the longest continuous exposures to basic cabin atmospheres in the history of bioastronautics, and has totally completed 166 experiments using approximately 7000 experimental animals requiring clinical laboratory support in excess of 40,000 laboratory determinations. As for the quality of research, there was a clear tendency toward more progressive and sophisticated approaches, and this was the first year where investigations were extended to morphology and biochemistry at the subcellular level. Other innovations which deserve mention were the psychopharmacological studies for the evaluation of performance in exotic atmospheres and the initiation of a vigorous toxicological qualification program for Apollo cabin materials.

The participation of the conferees in the discussions was extremely gratifying because it provided us with fresh ideas for new approaches and, at the same time, gave us the reassurance that we are proceeding in the right direction in building a solid foundation for the new and challenging area of space cabin toxicology.

Dr. Anthony A. Thomas

WELCOMING REMARKS

Jos. M. Quashnock, Colonel, USAF, MC

Commander
Aerospace Medical Research Laboratories

Last year when I addressed the participants of our first Conference, I pointed out three major problem areas for solution. The first one was the maintenance of truly uninterrupted long-term continuous exposure, simulating space cabin environments. This problem now has been solved and, as you can see from your program, experiments of this nature have already been extended to eight months' duration.

The second major problem area concerned trade-offs in areas of statistical evaluation of the toxicological data and the costs of these experiments. I believe that the presentations you will hear will prove unequivocally that there is safety in numbers. The simultaneous exposure of a large number of animals, which is a characteristic of our facility, has paid off in handsome dividends especially during the evaluation of histopathological changes.

The third problem area, the evaluation of space cabin materials, is now proceeding along lines mutually agreed upon by the Air Force and the National Aeronautics and Space Administration and you will be able to observe equipment specially devised for this purpose.

Thus, we can say that our first Conference has borne success and we certainly have learned a lot from the discussions and proceedings of that meeting. We hope that this second Conference will be equally profitable to all of us. I recognize many familiar faces and it gives me a great deal of pleasure to see them because it indicates that you also feel that you have not wasted your time on the first one.

This year's Conference is of necessity different in goal. We have more to offer than last year. The first Conference tried to develop basic approaches and philosophies. In the coming two days, you will be presented a tremendous amount of work, accomplished in the past year, that is truly new and unique information in this highly specialized area. You will also see that we have initiated new and more sophisticated techniques for evaluation of performance, that we have modified some of our existing equipment to make it easier to live with the facility, and we even had an unintentional fire which had a rather happy ending because it increased our confidence in the safety of this facility.

Another new theme in this second Conference is the increased emphasis on subcellular changes due to exposure to basic space cabin atmospheres. These changes are followed up by biochemical and electron microscopic investigation of the major organs and reflect much of the underlying mechanisms that we will have to address ourselves to in the future.

In closing, allow me to express my sincere gratitude to our illustrious Chairman for our scientific sessions, to our speakers and banquet speaker, and to all attending fellow scientists, who will be the real contributors to the success of the second Conference. I hope you will maintain an informal atmosphere and the free exchange of ideas.

INTRODUCTORY REMARKS

George E. Schafer, Colonel, USAF, MC

Deputy Commander
Aerospace Medical Division

It's a pleasure to represent the Aerospace Medical Division and to add our welcome to that of the Aerospace Medical Research Laboratories to all the members of this Conference. I think those of you who have scanned the agenda of this year's Conference will note that it's much more diversified than the first Conference was. This diversification represents an increased emphasis that has been placed on toxicology throughout the Air Force as well as other Governmental agencies. Efforts are increasing in areas of pharmacology, toxicology, and environmental pollution. Within the Air Force there's been increased emphasis on space cabin contaminants and other toxicological problems of closed environments. There's also been an increasing emphasis placed on toxicology by the Federal Government. I think we've all noticed that stiffer controls have been placed on the use of new drugs, insecticides, pesticides, and household chemicals, and that these stiffer controls, coupled with some changes in the Federal Air Pollution Control Program and the Clean Air Act of 1963, have brought this entire area into focus as a concern to all of the nation. Public attention has been brought upon this program because of its importance to the general welfare and to public health.

To emphasize this growing importance of toxicology research, the Aerospace Medical Research Laboratories were reorganized to enable the toxicology efforts to receive increasing emphasis and to have increased resources placed in this area. In addition to that, our fiscal '67 military construction program includes an item that will double the facilities and the capability of the Aerospace Medical Research Laboratories. I think this attests to a great extent the fact that we have placed increased emphasis on this program throughout the past year. Most of you are familiar with the overall program of the Laboratories and of Dr. Thomas' Toxic Hazards Division. I know that many of you attended the Conference on Propellant Toxicology.

I might also add that this research is sponsored to a certain extent with joint funding by the National Aeronautics and Space Administration. In addition to that, the work that goes on here is of value to the United States Public Health Service under the Federal Agencies. In the near future, some of the manned space programs that will come out within the Air Force will require even more demanding effort of this Laboratory and those people who support and contribute to the toxicology effort.

Much of the information - and this is not well understood by the public - that is generated for our space ventures and for some of the field environment contamination problems is applicable to the community, and I might cite just one important aspect to bring this point out. This past year there was a need to develop baseline information for a 2-week to a 90-day continuous exposure period on some common

air contaminants, ozone and nitrogen dioxide. This was necessary so that the effect of cabin atmospheres on the toxic properties of these agents could be studied. This baseline information that was so necessary for the actual experimentation and the protocol has a considerable fallout benefit to the public, because it applies to many community pollution problems. It provides data that can be extrapolated and used by the community and will benefit the public welfare.

I hope this Conference will be of as much benefit to you in all reaches of life as it is to the Air Force which is particularly concerned with the problem of toxicity in closed atmospheres.

SESSION I

TOXICOLOGY OF SPACE CABIN MATERIALS

Chairman

Dr. Elliott S. Harris
Manned Spacecraft Center
National Aeronautics and Space
Administration
Houston, Texas

**PARTS AND MATERIALS DATA RETRIEVAL PROGRAM
RELATIVE TO MATERIALS SELECTION IN TOXICOLOGY**

Elliott S. Harris, Ph. D.

**National Aeronautics and Space Administration
Houston, Texas**

The assurance of a safe, habitable atmosphere in the crew bay area of our spacecraft is of prime importance for astronaut safety and successful mission completion. As mission length increases, and the spacecraft becomes tighter, the testing and selection of materials for off-gassing properties and potential toxicity will assume increasing importance.

To accomplish the goal of a safe, habitable atmosphere, two approaches are taken. One, utilize an environmental control system which will remove noxious contaminants; and two, select materials for use which will contribute minimally to the contaminant load.

In an effort to minimize the trace contaminant load in the habitable area of the current generation spacecraft, the manufacturers select nonmetallic materials on the basis of application and off-gassing properties as determined by test.

To centralize the data obtained by manufacturers and test organizations; to reduce redundancy of testing effort to a minimum; and to provide a basis for toxicological testing, a data retrieval system was established at the Manned Spacecraft Center. Although this effort was initiated as a separate entity, it has been incorporated into an Apollo Parts and Materials Master File on the premise that the non-metallic materials used in the Apollo or LEM spacecraft will not differ too greatly from future generation spacecraft.

The Master File provides a program of parts and materials used in the Apollo and LEM spacecrafts. The computer will print-out the nonmetallic materials on a selective basis and provide the information presented below. Note that the information not only allows us to identify the material in question, but also the manufacturer of the material, its specifications, and the contractor who used the material. In addition, the spacecraft on which the material is used, and the location within the spacecraft are identified.

**PRIMARY INFORMATION
FROM P & M MASTER FILE**

**Material Common Designation
Manufacturer
Contractor
Specifications
Source of Part Using Material
S/C and Location
Part Identification
Cement
Coating, etc.**

Qualification Status
Description of Material by Modified IDEP Code
Date the Last Information was put into the
System

Sufficient information is provided to allow procurement of samples for testing at the Air Force's Toxic Hazards Facility, Wright-Patterson Air Force Base, and for both qualitative and quantitative off-gassing studies.

At the present time there are approximately 600 nonmetallic entries in the listing. There is some redundancy, and, in the case of adhesives, the catalysts are often listed separately. These areas will be corrected, reducing the actual total to nearer 500 materials. The information entered in this file was obtained by the General Electric Apollo Support Group under the direction of the Apollo Program Office R & Q A Branch. It was gleaned from examination of test plans, test reports, use lists, and a thorough drawings review.

The versatility and comprehensiveness of the program is enhanced by including in it elements of toxicological utility. However, in implementing this list, it was necessary to identify those elements of information which would be of most interest for direct retrieval. The second level of data insertion and retrieval, after the material has been identified, is shown below:

Qualification Status
Test Conditions
Gas
Pressure
Temperature
Time
Weight of Materials
Surface Area
Off-Gassing Data

Ideally, it is this information which aids in establishing priority for testing. The qualification status, the weight of the material used in the spacecraft, and the surface area of the material, when known, are of direct assistance. A material which is being used in large quantities, or with extensive surface area such as a coating, would receive priority over a material used in small quantities as an adhesive between nonporous surfaces. Similarly, a material which is being used, but has not been tested for out-gassing will receive priority over one which has thus been qualified.

Where a given material is used in more than one part, the weights and surface areas can be summated to provide an estimate of total usage. As previously stated, it is assumed that the proportions of materials used in the current spacecraft will also roughly resemble that used in future craft.

Off-gassing data is expanded as shown below:

Test Environment
Rate of Off-Gassing
Total Quantities Released
Compounds Identified

In addition to the information obtained from the materials qualification tests, provisions are made for the inclusion and retrieval of off-gassing rates, total quantities of gases released under specific test conditions, and the compounds which are identified. Mr. Pustinger of the Monsanto Laboratories reports this aspect of the testing in a subsequent paper.

As it becomes available, direct off-gassing information is entered according to the general groupings of the individual off-gassed compounds as listed below:

CLASSIFICATION OF COMPOUNDS

- Aliphatic
- Alicyclic
- Aromatic
- Heterocyclic
 - Halogenated
 - Phenols
 - Alcohols
 - Ethers
 - Esters
 - Aldehydes
 - Ketones
 - Epoxy
 - Organic Acids
 - Cyanides and Nitrates
 - Amines, Amides, Imines
 - Sulfur Containing CPDS
 - Nitro, Nitrate, Nitrite

By entering the information in this fashion, the materials contributing to a given contaminant load can be identified, and summated. Also, the total contaminants within a given group, such as esters, aldehydes, or ketones can be retrieved for study and evaluation purposes.

Since our prime concern is gaseous contaminants in spacecraft atmospheres, it was considered advisable to include in the program the results of the analyses of both the Mercury and Gemini charcoal absorbers. To this time these analyzers provide the only indication of the atmospheric contaminants to be found in the spacecraft. We realize that care must be taken in attempting to interpret the presence of some of these compounds since it is known that compounds such as the Freons found on the charcoal could not have been generated in the spacecraft. However, their repeated presence indicates that they are in the atmosphere, if even for a short period, and thus should be considered part of the overall contamination. Retrieval on the basis of a particular contaminant may ultimately lead to the source of the contamination.

For classification purposes another primary retrieval group is used. Those compounds for which a primary or secondary mode of action has been established, are classified according to those modes given below:

TARGET SYSTEMS

Pulmonary
Cardiovascular
Blood
Hemopoietic
Central Nervous System
Autonomic Nervous System
Peripheral Nervous System
Kidney
Liver
Mucosa
Simple Asphyxiant

In this fashion, all compounds having a given mode of action may be retrieved on the basis of that mode of action.

One additional source of contamination and contaminant information is man himself. His importance lies in his continuous production of gaseous substances which contribute to the microcontaminant milieu of the atmosphere, and fortunately or unfortunately, as the case might be, he is the one source of contamination that cannot be removed from manned spacecraft. Mr. James Conkle, of the School of Aerospace Medicine, has been analyzing closed environments for the purpose of identifying man's contribution to the microcontaminant picture, and his procedures and results are reported in a subsequent paper. As this information becomes available, it too will be entered into our system, and man will be assigned a part number for the sake of identification.

The goal of this effort is the definition of the possible contaminants which may be found in a spacecraft atmosphere, and from this an evaluation of the contaminant load placed upon man and the contaminant removal system.

The information retrieved from this data system is used for establishing areas of investigation for long term toxicity in closed environments. The ultimate goal is to establish tolerance levels for many of the compounds which will be present

The evaluation of contaminant control systems is another important use for the information obtained from this data retrieval system. MSC has recently acquired a trace contaminant generation simulator which has the capability of mixing up to 10 gases at a time with individual generation rates of 10^{-6} mole to 10^{-2} mole per hour. It can handle individual materials with boiling points of -253 to 102 C. One of the first uses to which this instrument will be put will be the evaluation of trapping systems and contaminant removal systems. Information obtained through the data file will be of use for this study.

DISCUSSION

FROM THE FLOOR: In compiling your information on the various organic materials, their uses and so forth, are you including the curing conditions and procedures?

DR. HARRIS: When known, the manufacturers' cure procedures are being used. In many cases, however, a material will go into a spacecraft after having sat around for months and even after it's put into the spacecraft, it may sit around for months longer, maybe a year, before the spacecraft is delivered, in which case this time lag is not simulated. This, of course, must be considered part of the cure, since during all of this time there is a certain amount of outgas evolving.

FROM THE FLOOR: Is the curing done at elevated temperature?

DR. HARRIS: Yes.

FROM THE FLOOR: This is included in the program?

DR. HARRIS: Yes.

FROM THE FLOOR: And when will information be available from this program?

DR. HARRIS: The program is in operation now. We are still pulling in the data. As I say, we have some 600 materials with a fair amount of redundancy. As the information on outgassing becomes available, this is programmed into it. We don't have all of that information. This, too, must be brought in from studies such as are being done here by Monsanto and other contractors on data about what they find coming off.

FROM THE FLOOR: Is there considerable information on gassing rates?

DR. HARRIS: No.

MR. EPSTEIN (Aerospace Corporation): Is this type of information generated and included?

DR. HARRIS: This type of information is being generated.

MR. MOBERG (Aerojet-General Corporation): Dr. Harris, what are you recording in the surface area measurements? Are you just taking geometrical measurements?

DR. HARRIS: That's right. These are strictly right off the drawings. We're not at this point considering microporosity; we're considering strictly what the microsurface area presented to the spacecraft atmosphere is. We will be concerned, let's say, with a paint or coating, the surface area presented by this as compared with, let's say, the surface area presented by an "O-ring" that's highly compressed. We're not going to, at this point, concern ourselves with the microporosity of that coating or the "O-ring". This is too massive a problem.

GAS-OFF STUDIES OF CABIN MATERIALS

F. N. Hodgson
John V. Pustinger, Jr.

Monsanto Research Corporation
Dayton, Ohio

INTRODUCTION

A potential problem in manned space programs is the possible contamination of the cabin atmosphere. Considerable data on trace, atmospheric contaminants from the atomic submarine programs and from various space cabin simulation tests have shown that sources of contamination may include biological products and the materials of construction.

During the past 18 months, we have been involved in two programs to establish the gas-off and possible oxidation products from individual cabin materials by using bench-scale environmental simulators. Approximately 150 candidate materials are being tested and over 1500 gaseous environments will be analyzed to identify the gas-off products and to estimate their concentration and gas-off rates.

Materials of a wider variety, such as partially fabricated spacecraft components and freshly prepared paints and coatings, are being evaluated. All materials are commercial products.

The test atmospheres are analyzed by a variety of gas chromatographic and mass spectrometric methods. Whenever necessary infrared adsorption spectrophotometry and chemical tests have been applied.

EXPERIMENTAL PROCEDURE

Experiments have been performed under two separate programs. Environmental conditions for these tests are shown in tables I and II.

All candidate materials are stored in 9-liter, borosilicate glass chambers, for which special inlet systems were constructed from borosilicate glass and Teflon stopcocks.* Two hundred chambers are used on a staggered schedule to permit analyses of 1500 gaseous atmospheres.

Test atmospheres from the gas-off chambers are analyzed by several different analytical operations.

1. Gas chromatographic and mass spectrometric analyses of aliquots (25 and 125 ml, respectively) of chamber atmosphere (Sensitivity - 10^{-7} to 10^{-8} gram).

*Pustinger, J. V., "Analytical Techniques for Identification of Gas-Off Products from Cabin Materials". In Proceedings of the Conference on Atmospheric Contamination in Confined Spaces, 30 March - 1 April 1965, AMRL-TR-65-230.

TABLE I

ENVIRONMENTAL CONDITIONS FOR
GAS-OFF EXPERIMENTS
(PROGRAM 1964-1965)

Atmospheres - air and oxygen at
20-40% R. H.
Storage Times - 30, 60, and 90 days
Temperature - 23 ± 2 C

Pressure - (a) air at 1 atmosphere
(b) oxygen at 5 psia

Sample Pretreatment - preparation
according to manufac-
turer's directions

TABLE II

ENVIRONMENTAL CONDITIONS FOR
GAS-OFF EXPERIMENTS
(PROGRAM 1965-1966)

Atmospheres - oxygen at 20-40% R. H.

Storage Times - 14, 30, 60, and 90 days
Temperature - 23 ± 2 C (30-, 60-, 90-
day periods)
 68 ± 2 C (14-day period)

Pressure - 5 psia

Sample Pretreatment -

- (a) preparation accord-
ing to manufacturer's
directions
- (b) continuous pumping
at 10^{-1} torr

2. Mass spectrometric identification of gas chromatographic fractions (Sensitivity - 10^{-7} gram).
3. Gas chromatographic analysis of an aliquot (approximately 3 ml) of chamber atmosphere for carbon monoxide and methane after catalytic reduction of the carbon monoxide (Sensitivity - 10^{-8} gram).
4. Gas chromatographic analysis for HCN after concentration in a GLC precolumn from a large volume (approximately 3 liters) of chamber atmosphere (Sensitivity 10^{-7} gram).
5. Condensation of gas-off products at -195 C from total 9 liter volume, fractionation of the composite by gas chromatography, and characterization of the fractions by mass spectrometry and by infrared spectrophotometry (ref. AMRL-TR-65-230).

RESULTS AND DISCUSSION

Contaminants detected in the chamber atmospheres are listed in table III.

Gas-off products from cabin materials are not mystical fumes, but are most-ly commonplace chemicals encountered whenever a can of paint or a tube of house-hold cement is opened. As expected, the major yields of gas-off products occur with the candidate paints and coatings, which desorb entrapped solvents and plasticizers. Lesser, but still significant, amounts of contaminants result from oxidation, hydrolysis and sublimation processes.

Even after pretreatment at 25 C and 10^{-1} torr, considerable amounts (up to 80 mg/10 grams of candidate material) of gas-off products were detected from

TABLE III
TYPES OF COMPOUNDS DETECTED

<p><u>I Inorganics</u></p> <p>Ammonia Carbon monoxide Carbonyl sulfide Carbon disulfide Carbon dioxide</p> <p><u>II Alkanes</u></p> <p>Methane Variety of C₅-C₇ hydrocarbons, as naphtha or petroleum ether</p> <p><u>III Alkenes</u></p> <p>Trichloroethylene Ethylene</p> <p><u>IV Hydroxy Compounds</u></p> <p>Ethanol 2-Ethoxyethanol n-Propanol 2-Propanol n-Butanol Phenol</p> <p><u>V Ethers</u></p> <p>Ethylene oxide</p> <p><u>VI Alkyl Halides</u></p> <p>Trichlorofluoromethane Variety of low molecular weight, C₆ and lower, chlorofluorocarbons</p>	<p><u>VII Carboxylic Acids and Their Derivatives</u></p> <p>Acetic acid 2-Ethoxyethylacetate Methyl methacrylate Ethyl acetate γ-Butyrolactone</p> <p><u>VIII Aldehydes</u></p> <p>Formaldehyde Acetaldehyde Propionaldehyde Furaldehyde</p> <p><u>IX Ketones</u></p> <p>Acetone Methyl ethyl ketone Methyl isobutyl ketone</p> <p><u>X Aliphatic Nitrogen Compounds</u></p> <p>Ethylamine</p> <p><u>XI Benzene and Its Homologs</u></p> <p>Benzene Toluene Xylenes C₃ alkyl benzenes</p> <p><u>XII Aryl Halides</u></p> <p>Dichlorobenzene 1, 2, 4, 5-Tetrachlorobenzene</p> <p><u>XIII Silicon Compounds</u></p> <p>Various cyclic and linear methylsiloxane polymers Trimethylsilanol</p>
--	---

materials prepared immediately prior to testing, e. g., coatings, paints, and adhesives. An analysis of an epoxy resin is shown in table IV.

TABLE IV
GAS-OFF PRODUCTS FROM AN EPOXY RESIN

Components	Weight of Components mg/10 gms of Candidate Material			
	14 Days (68 C)	30 Days (25 C)	60 Days (25 C)	90 Days (25 C)
Acetone	1.4	1.4	2.1	2.8
Ethanol	0.2	0.2	0.2	0.2
Benzene	0.04	0.03	0.03	0.05
Methyl isobutyl ketone	59	38	44	48
Toluene	2.1	4.1	4.0	5.6
n-Butanol	11	12	13	18
Xylene & Ethyl benzene	9.7	11	11	14
Carbon monoxide	0.30	0.087	0.12	0.17
Methane	0.014	0.002	0.006	0.008

Very little (<0.001 mg/10 grams of candidate material) gas-off products were evolved from materials submitted as fabricated sections.

In most cases, larger amounts of contaminants are observed after 14 days at 68 C than after 30, 60, and 90 days at 25 C. Representative analyses for gas-off products from an adhesive material and a phenolic resin are listed in tables V and VI.

TABLE V
GAS-OFF PRODUCTS FROM AN ADHESIVE MATERIAL

Components	Weight of Components mg/10 gms of Candidate Material			
	14 Days (68 C)	30 Days (25 C)	60 Days (25 C)	90 Days (25 C)
Ethylene	0.4	0.01	0.03	0.05
Ethylene oxide	0.06	0.005	0.01	0.02
Carbon monoxide	0.17	0.007	0.02	0.05
Methane	0.04	N.D.	0.03	0.03

TABLE VI
GAS-OFF PRODUCTS FROM A PHENOLIC RESIN

Components	Weight of Components mg/10 gms of Candidate Material			
	14 Days (68 C)	30 Days (25 C)	60 Days (25 C)	90 Days (25 C)
Acetone	0.3	0.01	0.01	N.D.
Ethanol	4.2	0.5	0.4	0.2
Carbon monoxide	0.2	0.03	0.06	0.05
Methane	0.005	N.D.	N.D.	0.005

Surprisingly high levels of carbon monoxide were observed for some materials when stored for 14 days at 68 C. Typical analyses for 14- and 30-day periods are shown in table VII.

TABLE VII
GAS-OFF PRODUCTS - CARBON MONOXIDE AND METHANE

Candidate Material	Gas-Off Period (Days)	Temp. (C)	CO (mg/10 g)	CH ₄ (mg/10 g)
Silicone Elastomer	14	68	0.001	0.04
	30	25	0.001	N.D.
Polypropylene	14	68	0.001	0.003
	30	25	0.001	N.D.
Epoxy Resin A	14	68	0.03	0.007
	30	25	<0.001	N.D.
Epoxy Resin B	14	68	1.0	0.01
	30	25	0.04	0.003
Modified Melamine	14	68	4.1	0.003
	30	25	2.0	0.002
Marking Material	14	68	1.0	N.D.
	30	25	0.005	N.D.
Black Ink	14	68	29	0.9
	30	25	11	0.1
Diallyl Phthalate	14	68	1.3	0.1
	30	25	0.006	N.D.

An extremely large increase (200 fold) in carbon monoxide level (table VII) was observed with diallyl phthalate when the storage temperature was raised from 25 to 68 C. To determine if oxidation or decarboxylation is the dominating mechanism, the chamber containing the material used in the 30-day test at 25 C was purged of its atmosphere and was recharged with prepurified nitrogen at 5 psia. After storage for 14 days at 68 C, 0.4 mg of carbon monoxide/10 grams of material was measured. These data suggest that most of the carbon monoxide produced from diallyl phthalate during storage under oxygen (5 psia) for 14 days at 68 C is due to oxidation. The 0.4 mg of carbon monoxide/10 grams of diallyl phthalate produced in the nitrogen atmosphere may be due to decarboxylation or may result from reaction with previously absorbed oxygen. Data are not conclusive, but the latter mechanism is more probable.

Many factors affect the quantitative analyses of gas-off products. Some of these are: (a) physical state and composition of each specimen, (b) adsorptive characteristics of the gas-off chamber, (c) storage time and temperature, (d) nature of the chamber atmosphere, (e) method of sampling the chamber atmosphere, and (f) method of analysis. Slight variations in each of these can appear as large relative differences when comparing analytical data for extremely small amounts of gas-off products.

Variations in the physical properties and composition of each specimen appear to have the greatest effect on the gas-off analyses. Precision of analyses can be improved by applying restrictions as to size, shape, and thickness, when comparing different test specimens. However, consideration must be given to uniformity of samples, changes in proprietary mixes between sample lots, freshness of sample, and amount of exposed surface. Small differences in any one of these can offset the restrictions on the physical dimensions.

The adsorptive characteristics of the inner wall of the glass chamber have a marked influence on the nature and the amounts of gas-off products. Low molecular weight methyl siloxanes were detected as coatings on the glass walls in the tests with silicone-based materials. Not only are the gas-phase analyses for trimethylsilanol and low molecular weight silicones affected, but the coating on the glass surface provides an excellent medium for the potential absorption of organic compounds from the chamber atmosphere. In addition, the adsorption sites on the glass surface can remove significant amounts of polar gas-off products, e. g., alcohols, acids, ketones, and aldehydes, from the gas phase.

The general effect of storage time was determined in tests, where individual specimens were stored for continuous 30-, 60-, and 90-day periods, and in others, where the chamber atmospheres were analyzed, purged, and recharged at 30-day intervals. In the continuous tests at 25 C, little increase in gas-off products occurred after the first 30 days.

Generally, the tests, in which the chamber atmospheres were analyzed, purged, and recharged every 30 days for a cumulative time of 90 days, show a reduction in gas-off products after each purging. These data also show some tests in which the amounts of gas-off products from the second 30-day period are equivalent to the first and are almost equal to the total amount of gas-off products from the continuous 90-day tests.

There are indications that a relatively constant amount of gas-off products is in the gas phase during continuous 30-, 60-, and 90-day storage periods, whereas, repeated evolution of gas-off products occurs if the atmosphere above the candidate material is changed. The amounts of gas-off products accumulated during three purging and recharging tests may be two to three times the quantities measured for a continuous 90-day storage.

The methods for sampling the chamber atmosphere can strongly influence the relative amounts of gas-off components isolated for analysis. Problems associated with aerosol formation, entrainment of vapor, adsorption, and possibly hydrolysis or oxidation during isolation and concentration of all the gas-products in each 9-liter chamber by condensation at -195 C, prevented application of this technique in the general quantitative analytical method. Since up to fivefold differences in analytical results were observed when comparing data for duplicate chambers, this method was rarely used.

Better repeatability of analyses ($\pm 100\%$ at the 0.001 mg level and $\pm 25\%$ at the 0.01 mg level between duplicate chambers) is obtained when analyzing aliquots from the chamber atmospheres. Although variations between duplicate chambers were observed, no measurable differences were detected from aliquots taken from the same chamber. The high sensitivities of mass spectrometry and gas chromatography with a flame ionization detector permitted use of relatively small, representative samples of chamber atmosphere with no impairment of the detection levels. By the use of effluent splitters and packed capillary tubes cooled to -195 C, identification of 10^{-7} gram of material eluting from the gas chromatograph is possible.

The wide variety of gas-off products produced in these tests required the use of several analytical techniques. There were several cases in which gas-off components were detected by mass spectrometry, but not by gas chromatography. Other analyses were more easily obtained by gas chromatography, than by mass spectrometry. For a complete characterization of all components, several techniques, e. g., gas chromatography, mass spectrometry, infrared spectrophotometry, and a variety of classical chemical tests, were used.

CONCLUSIONS

We have concluded that:

- (1) Qualitative identification of gas-off components is possible to the level of 0.1 ppm in the gaseous atmosphere. Concentration and isolation methods can lower the detection level to values much less than 0.1 ppm.
- (2) Estimates of the amounts of gas-off components can be made from mass spectrometry and gas chromatography analyses, but, at extremely low levels, considerable variation in the measurements can arise from sample inhomogeneity, occlusion of solvents and plasticizers, slight difference in composition of sample lots, and adsorption phenomena.
- (3) Whenever possible, materials should be evaluated in their final form and under the conditions of use.

- (4) Pretreatment of candidate materials should simulate conditions encountered in use.
- (5) To provide quantitative data for meaningful comparison between testing laboratories, some standardizations of sample preparation, i. e. , size, shape, exposed surface, etc. , should be made. The testing laboratories must recognize that the level of gas-off problems is generally so small that variations in proprietary mixes, sample homogeneity, occlusion of solvents, and adsorption in the gas-off chamber may influence the yields of gas-off products to a greater degree than small differences in size and shape.

ACKNOWLEDGMENT

This work was supported by the Aerospace Medical Division, Air Force Systems Command, United States Air Force, under Contracts AF 33(615)-1779 and AF 33(615)-3377, monitored by the Aerospace Medical Research Laboratories, Wright-Patterson Air Force Base, Ohio.

The authors acknowledge the invaluable assistance of B. E. Boggs, R. L. Evers, and R. R. Ferguson.

DISCUSSION

DR. HARRIS: Are there any questions?

DR. FURST (University of San Francisco): Did you ever find any metallic contaminants?

MR. PUSTINGER: Most of the materials we have been testing have been nonmetallic.

DR. FURST: But they do use the metals as catalysts, I'm wondering about nickel carbonyl and so on.

MR. PUSTINGER: We have not detected any.

MR. EPSTEIN (Aerospace Corporation): Have you looked into batch-to-batch variations in the products produced?

MR. PUSTINGER: We have received several materials of which we've had two batches and there have been extensive differences. It's been a matter of maybe five- to tenfold differences in the gas-off products.

DR. BENJAMIN (NASA Headquarters): You express your gas release as milligrams per 10 grams of material. Wouldn't it be more meaningful if you express it in terms of mols per square inch or square centimeter?

MR. PUSTINGER: Well, I don't know whether you noticed on the slide of the gas-off chamber, our samples come to us in various forms. They may be tubular pieces of material. They may be paints and coatings we must prepare ourselves. We have received electrical components where we physically don't know what the dimensions are; but what we are relating, we feel, is best to the weight basis. Your suggestion has merit, obviously. We have received, for example, conduit, 12 feet in length and 5 inches in diameter, it looks like sewer pipe, and we have problems in preparation. We have a wide variety of materials to test.

MR. DEUSS (Douglas Aircraft Company): Can you make a generalized statement as to what effect the previous vacuum treatment has on the resultant outgassing?

MR. PUSTINGER: It does reduce the resultant outgassing, mostly from coatings and adhesives. On other materials we find that, although we're pumping for 24 hours continuously, even after this we see extensive gas-off. We feel that it's going to take more than a simple pumping for 24 hours to remove most of the gas-off products.

DR. HARRIS: May I add something here? Have you done anything to relate the thickness of your material to the losses during this gas-off period?

MR. PUSTINGER: Obviously this is one problem that should be part of gas-off tests. We have not done any significant amount of testing on this, but definitely it will affect it. Generally, we try to make the coatings as thin as possible.

DR. STOKINGER (U. S. Public Health Service): You mentioned wall absorption of these off-gas products. How do you get them desorbed, or is this a large enough factor to make a difference?

MR. PUSTINGER: It's difficult to say whether it's a large enough factor to make a difference. When you have a 9-liter chamber volume it is definitely a factor. For example, the silicones and the silicone polymer siloxanes that we have detected are extensively deposited on the wall of the glass chamber. We haven't had time to spend on this program to isolate enough of the material to relate quantity of the solids to the surface area characteristics of the chamber. This will depend on whether the chamber is glass or metal. If you use Teflon you're going to have problems there too.

MR. WILLARD (Honeywell Aeronautical Division): Did you do any work to determine whether the presence of a diluent gas had any effect on the gas-off product or rate?

MR. PUSTINGER: Well, we related some of our data earlier in the first year's program to oxygen at 5 psi and air at one atmosphere. Now you can figure out what the molar distribution of oxygen would be in this respect; but with the relationship we found, we would be more inclined along the line that more gas-off products are yielded in the test at the reduced pressure, and we figured most of it to be a low pressure effect, at least at 25 C. Now if you do this at a higher temperature, I don't know what will happen. Our program doesn't call for this.

TOXICOLOGICAL SCREENING OF SPACE CABIN MATERIAL

B. D. Culver, M. D.

Aerojet-General Corporation
Azusa, California

INTRODUCTION

I've been going to meetings such as this Conference for several years where we have talked among ourselves - without ever having gotten very far - about studying toxicity of space cabin atmospheres and the toxicity due to materials of construction. Finally, it was decided that a first start had to be made to study toxicity of materials at reduced pressures under conditions similar to those found in space cabins insofar as practicable. This paper describes that first start and emphasizes that it is only a beginning, then I will propose the next step to be taken in investigating the effects of space cabin materials upon animals.

First, we had to design and build a suitable facility for such animal exposure experiments. Figure 1 shows a flow diagram of an individual life-support loop; the complete system contains three such loops. The air atmosphere which is applied to the animal chamber flows through the system as follows: air goes through a dehumidifier and a water chiller, the coils of which operate at 45 F. The circulation for the system is provided by two blowers installed in parallel in order to have redundancy and to avoid overheating of a single pump. From intake the air flows through lithium hydroxide scrubbers and by this filtering process an atmosphere with below one-half percent carbon dioxide is maintained. The atmosphere is essentially 100% oxygen. A paramagnetic oxygen analyzer and an infrared carbon dioxide analyzer are employed to monitor continuously the oxygen and carbon dioxide concentrations; in addition, samples for analytical oxygen determinations are taken. A flowmeter monitors the flow rate through the system. After passing through the lithium hydroxide scrubbers, the air goes to an oven in which gas-off products are evolved from the materials heated at an established temperature of $155\text{ F} \pm 5$.

The entire system is maintained at 5 psia pressure because it is located in one of the Thomas Domes - capable of operating at such pressures - of the Toxic Hazards Research Unit at the Aerospace Medical Research Laboratories. Visible in figure 2 are the animal exposure chambers which are an integral part of the closed life-support loop. Figure 3 shows the console with the ovens in which the material samples are placed; this is also located inside the dome. Visible in the figure, but not too clearly, is one of the lithium hydroxide scrubbers. The samples are placed in the oven on a stainless steel tray, such as the one shown in figure 4. These samples are prepared in the laboratory in much the same fashion as those described to you in the previous paper.

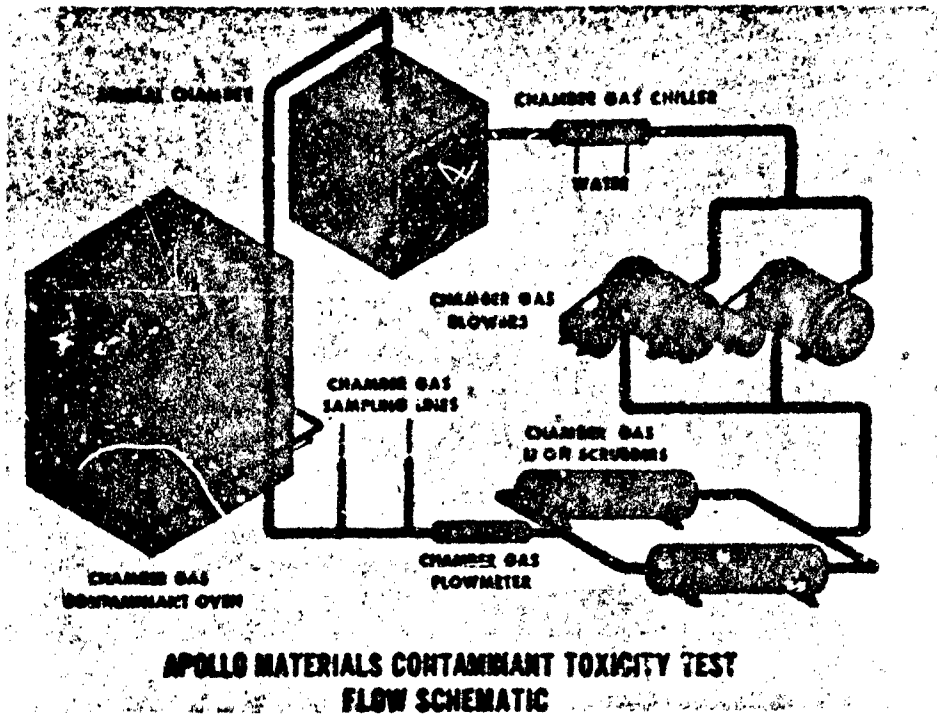

Figure 1. APOLLO MATERIALS CONTAMINANT TOXICITY TEST FLOW SCHEMATIC

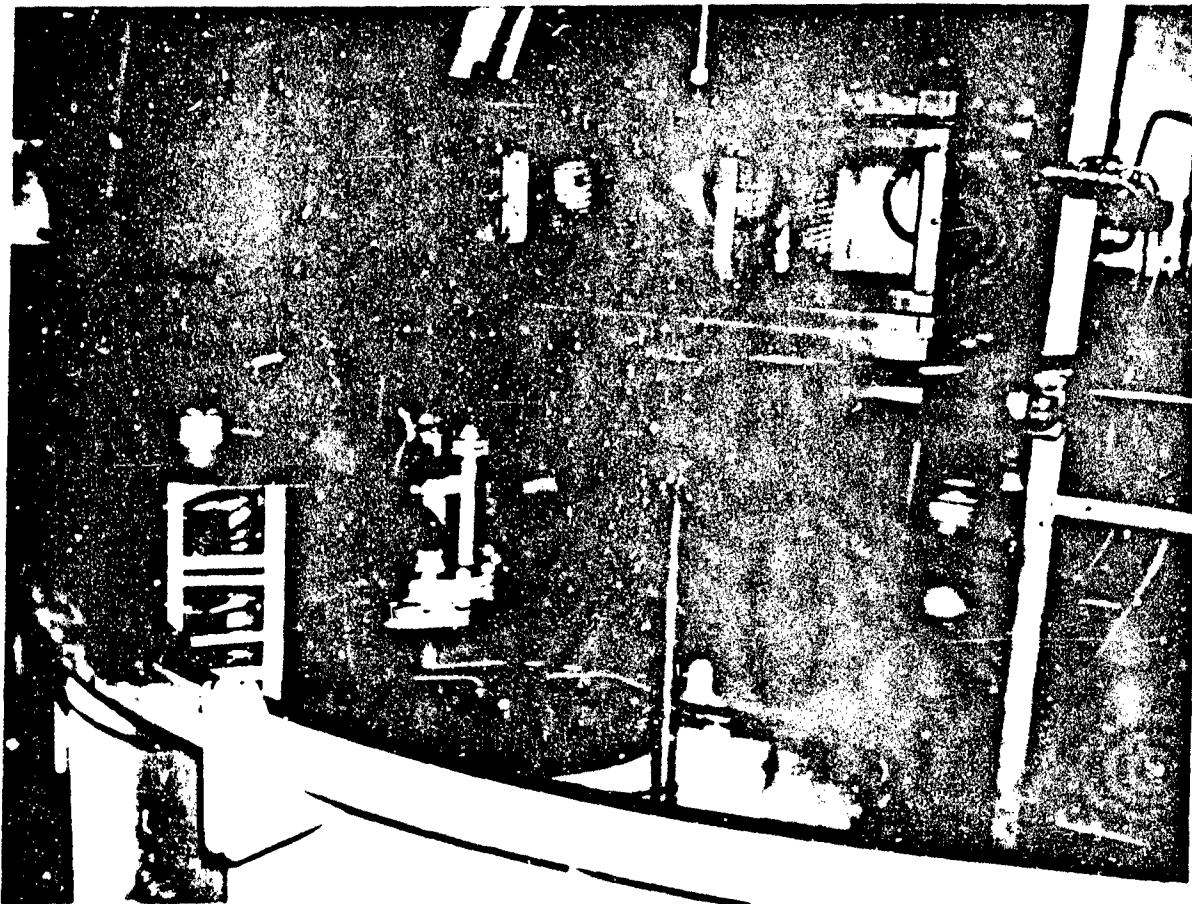

Figure 2. ANIMAL EXPOSURE CHAMBERS FOR APOLLO TOXICITY SCREENING TESTS

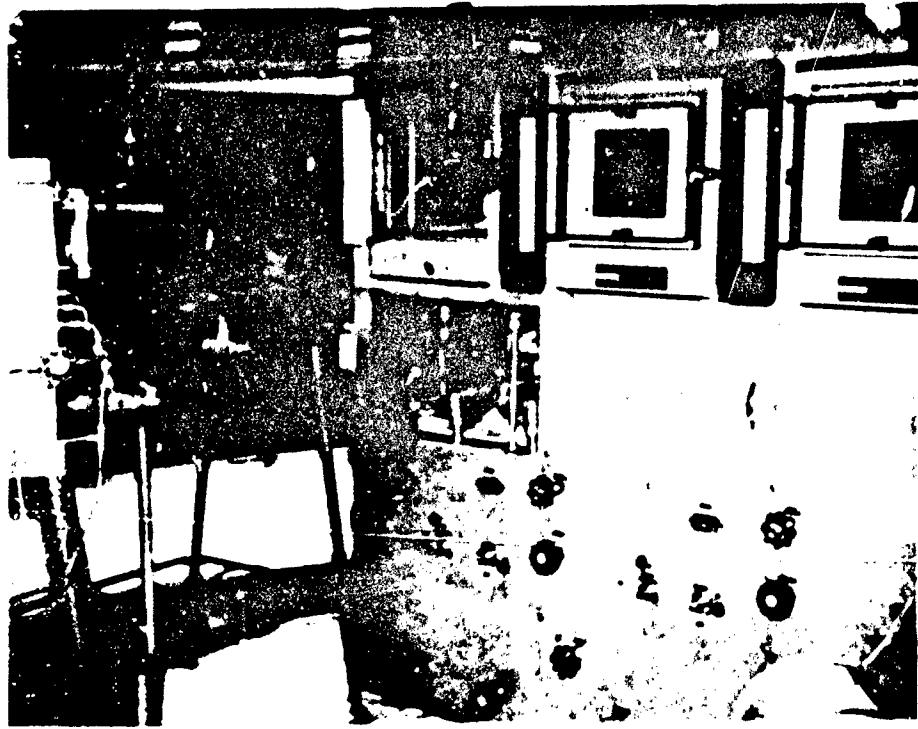

Figure 3. OVEN CONSOLE FOR TOXICITY SCREENING TESTS OF APOLLO SPACE CABIN CONSTRUCTION MATERIALS

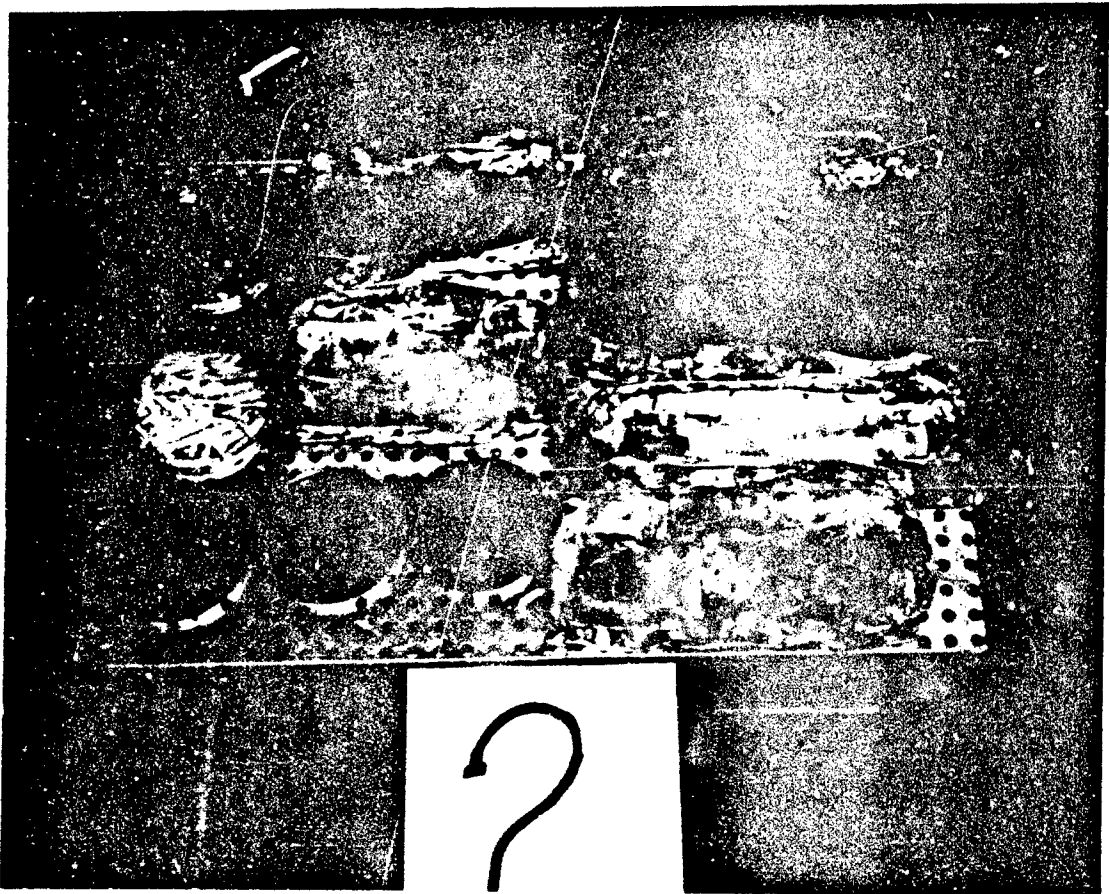

Figure 4. SAMPLE TRAY OF APOLLO SPACE CABIN CONSTRUCTION MATERIALS

In the animal chambers are placed 20 rats and 25 mice. Conditions of exposure are 75 F + 5, 50% relative humidity + 10% and, as I indicated, we maintain the carbon dioxide concentration below one-half percent and the total pressure at 5 psia. To date, we have exposed animals for a week to each of four groups of materials. These are mixed groups of resins and mounting materials; we are using 10 to 18 materials per group.

We were in the process of exposing animals to two other groups of materials when a problem developed. The air blowers in the system are driven by motors connected to them by rubber belts. One of the pumps failed mechanically. The atmosphere in which this system is placed, as well as the internal atmosphere for the system, is pure oxygen. The friction heating caused a fire which rather completely destroyed the unit. The system has now been rebuilt and we are in the process of rerunning the fifth and sixth group of materials, after which we will go back and rerun our first group of materials.

We have seen no changes in the animals exposed under these conditions except for the first group. There was a slight loss of weight in the rats exposed to the first group of materials - following the period of exposure the animals were kept and observed for a week - they did undergo a weight loss at a 0.01 level of statistical significance. Whether or not this is biologically significant will have to be determined by another experiment following these acute studies - and I consider these 1-week exposures to be acute studies. Later, when larger batches of materials are available, we will perform 60-day continuous chronic exposures.

We have not measured the concentration of contaminants in the atmosphere. As I indicated, this is a first step in toxicological definition of space cabin materials. If we consider the weight loss sustained by the materials in our system and calculate the nominal concentrations in our chambers, our runs range from 8,000 to 20,000 parts per million calculated on the basis that the average molecular weight of the gas-off products is 100. Now, it is probable that we are not operating at those concentrations. The wall effects, the possibility of leakage, all tend to reduce this nominal concentration. Further, we do not know what percentage of the gas-off materials from the plastics is water.

I would like to comment for a minute on the status of the criteria for acceptance of materials in spacecraft. The Apollo materials specifications are primarily engineering specifications related to the change in the materials properties of importance to the design engineer. The only aspects of the material specifications for the Apollo which are related in any way to toxicity are the requirements that material not give off more than 100 parts per million by way of total organic content and, further, that the gas-off products should not smell bad, as measured by an olfactometer. I won't discuss whether or not these are significant toxicologically.

At the other end of the spectrum - if you consider our experiments to be the most primitive start - it is desirable to quantify completely the constituents of the atmosphere arising from materials to which we expose animals. The task of doing this is discussed in Mr. Conkle's paper. The problem is of such immense magnitude. It is my belief, however, that there are some steps in between the most primitive and the most sophisticated definitions of the atmosphere. Since we have to make compromises with practicality in order to provide space cabin

designers with useful information, the compromise I recommend that we take next is this: the analytical chemists, who are doing some very fine work today in the parts per billion range in defining atmospheric constituents, should be asked into what fractions they can break their samples, maintaining a high sensitivity, still being quantitative and meaningful to the toxicologist. Can they tell us what are the total ketones, total aldehydes, total fatty acids, total aromatics, and other classes of compounds? If they can tell us this, then we can design our exposure system to monitor these classes of materials and we can start studying the range of response to total constituents in these various families or fractions.

DISCUSSION

DR. MAC FARLAND (Hazleton Laboratories): When you spoke of a 1-week exposure, is this 24 hours a day, 168 hours a week?

DR. CULVER: Yes, sir.

DR. MAC FARLAND: I want to ask you about the type of pump that was used in this closed system for circulating the atmospheres. Is it a positive rotary air blower, centrifugal fan, or what?

DR. CULVER: It's essentially a carbon vane vacuum pump that runs dry, no oil.

MR. WAGNER (Division of Occupational Health Service): Did you say that the relative humidity in the animal chamber was 10%?

DR. CULVER: No, it's 50% plus or minus 10%.

MR. BROOKSBY (NASA Ames Research Center): What did you use for controls in this 1-week exposure?

DR. CULVER: I'm sorry, I did not mention this. We had two similar groups of control animals. The first group of controls was kept at the same 5 psia, 100% oxygen, the same humidity, in the same dome, but not inside the small exposure chambers, which, by the way, have a volume of 200 liters. The domes are about 800 cubic feet. That's the first set of controls. The second set of controls was kept in air at ambient pressure and in isolated cages away from other animals.

DR. LEON (NASA Ames Research Center): I notice on your diagram the gases were coming out of the oven directly into the animal chamber without a cooling system between. Was the temperature of the gases coming into the animal chamber at the normal ambient temperature of the chamber?

DR. CULVER: Yes. Actually, not all of the gases circulated in the system go through the ovens on the same pass. We also have a bypass and we split part of the oxygen stream and keep it at a temperature somewhat lower than the exposure chamber. The two streams are then remixed prior to entering the exposure chamber.

DR. KEPLINGER (University of Miami): In the first slide you showed a diagrammatic scheme of what I thought was a completely closed system. Is this right?

DR. CULVER: It is completely closed.

DR. KEPLINGER: This is operated at 5 psi? The question then is why was this whole system put into the dome?

DR. CULVER: First, the little closed system is operated at about 1/3 of an inch of water below 5 psia. It's placed inside the dome, which is kept at 5 psia. There is a bleed valve which will allow oxygen from the dome to enter the small system to replace oxygen which is taken up by the animals. The other reason for placing this system within the dome is that leaks are extremely critical in this kind of work; a few milliliters outside leak per hour is enough to significantly dilute the concentration of the oxygen in the little 200-liter system. Because of problems of making plumbing leak-tight, we put the whole thing inside a larger low pressure envelope.

DR. COSTA (Roswell Park Memorial Institute): Two questions: how do you generate your oxygen? Second question, what tests are you actually doing on your animals? How do you test for toxicity, simply by weight loss?

DR. CULVER: We purchase liquid oxygen and run it through a heat exchanger that converts it to gaseous oxygen for admission to the chamber. The answer to the second question: this, as I indicated, is a rough first approach, so that all we are doing is measuring weight loss, observing the animals for signs of clinical change, and, of course, we record death. We also do a very complete tissue pathology evaluation should we see any gross pathology changes indicating it would be of value to do so; but we're not doing a complete blood study or a complete battery of testing at this time with this first approach.

DR. VORWALD (Wayne State University): You speak of acute, not chronic studies. In your projected studies, from a chronic point of view, are you going to keep your animals longer than 90 days?

DR. CULVER: Are you asking if, following a 60-day exposure, we are going to retain the animals longer than 90 days?

DR. VORWALD: Yes. Or are you going to expose your animals to some of these low concentrations for the length of life, for example?

DR. CULVER: That would be considerably downstream to do this. I think we have to keep in mind the fact we're trying to get information that will be concurrent to the space program. We're concerned at the present time with people who are going to be kept in the spacecraft for 14 days. I think that as our ability to penetrate space further on longer missions increases, then we'll have to do the kind of studies you are talking about. I feel personally that now is not too early. In fact, the lead time that we will have to adequately define the atmospheres of closed spacecraft may be too short for these longer missions. This should be started soon. The major problem is the allocation of our national budget and facilities for this type of work.

DR. HARRIS: Just one point - that is, these animals are in a log phase of growth. They're increasing, I think, 30-50% of their body weight in that 7-day period.

DR. CULVER: Yes.

DR. HARRIS: One other aspect, aren't you also doing some organ-to-body weight ratios on these animals?

DR. CULVER: Yes, we are.

CONTAMINANT STUDIES IN CLOSED ECOLOGICAL SYSTEMS AT THE USAF SCHOOL OF AEROSPACE MEDICINE

James P. Conkle

USAF School of Aerospace Medicine
Brooks Air Force Base, Texas

INTRODUCTION

Contaminant analyses in sealed atmospheric systems have a twofold purpose. One, studies must be accomplished to establish the source and concentration of trace contaminants. This type of systematic study of man and equipment is essential to insure that contaminants in the atmosphere are controlled adequately and do not limit duration of the mission. The second purpose of contaminant analyses is to produce detailed information of the trace contaminant concentrations, while studying the physiologic suitability of an atmospheric gas mixture. Excessive levels of contaminants might produce physiologic responses that could lead to inaccurate conclusions concerning the gas mixture being evaluated.

This paper presents information on the concentration of contaminants identified and quantitated during two experiments. The United States Air Force School of Aerospace Medicine in conjunction with the National Aeronautics and Space Administration designed and conducted a 27-day experiment at 760 mm Hg (oxygen, 20%; nitrogen, 80%) to define the contaminants associated with human occupancy of a sealed environmental simulator (ref 6, 7). A second experiment of 56 days duration was performed to evaluate the suitability of a helium (30%) - oxygen (70%) atmosphere at 258 mm Hg (ref 1, 8).

METHODS

The 27-day study was divided into three parts: a preliminary stabilization period of 2 days, an unmanned background period of 11 days, and a manned period of 14 days. The unmanned portion provided information about the contaminant materials associated with the chamber and support items that would be required during the subsequent manned portion. Four volunteers occupied the chamber during the manned portion of the study. The subjects were sustained on a liquid diet* and permitted limited hygienic activity.

The 56-day study was conducted to evaluate a 70% oxygen-30% helium atmosphere at 258 mm Hg. During this experiment four volunteers occupied the chamber and were permitted to shave and bathe. Their diet consisted of freeze-dehydrated food cubes (ref 9).

During both studies direct sampling techniques and cryogenic concentration and subsequent analysis were used for contaminant detection (ref 1, 7, 8).

*U. S. Army Natick Laboratories, Natick, Massachusetts

Methane and carbon monoxide were analyzed by flame ionization gas chromatography and infrared spectrophotometry, respectively. Dual flame ionization gas chromatography was used for the analysis of unconcentrated samples obtained directly from the chamber (ref 1, 7).

Multistage cryogenic trapping systems (ref 5) were operated daily during the 27-day study (ref 7) and periodically (ref 1) during the 56-day study to obtain cryogenically concentrated samples for subsequent analysis. During the 27-day study, four sample sets (108) were obtained daily and analyzed by Arnold Engineering and Development Center, Lockheed Missile and Space Company, Melpar, Inc., and Von Karman Center, Aerojet-General Corporation (ref 2, 11, 12, 13). Eighteen samples were obtained during the 56-day study and analyzed by Melpar, Inc., and Von Karman Center, Aerojet-General Corporation (ref 2, 11).

The 27-day experiment was specifically designed to study trace contaminants and the gas lost from the simulator was maintained at a minimum. The total gas loss from the simulator was determined to be 5635 liters. The 56-day study was concerned with the suitability of a He-O₂ mixture, and to maintain low levels of nitrogen the gas exchange rate was not minimized. The trace contaminants were monitored for safety purposes and effect on physiological response.

RESULTS

Rapid, initial increases in the carbon monoxide concentration were observed in both studies (ref 1, 7). In the 27-day study the increase was observed soon after the men entered the closed system, and in the 56-day study when ventilation was stopped. The concentration during the manned portion of the 27-day study ranged from a low of 4.8 mg/m³ to a high of 23.7 mg/m³. During the 56-day experiment, concentrations ranged from a low of 1.0 mg/m³ to a high of 9.5 mg/m³ with a 56-day mean of 6.4 mg/m³.

The methane concentration during the 27-day experiment increased from 20.9 mg/m³ the day after men entered the chamber to a high of 84.6 mg/m³. The 56-day experiment methane concentrations ranged from a low of 4.7 mg/m³ to a high of 13.7 mg/m³, with a mean of 7.1 mg/m³ (ref 1). The values for carbon monoxide and methane during the 56-day experiment do not represent the total production, since no attempt was made to minimize the gas exchange rate as contrasted to the minimum gas exchange in the 27-day experiment.

No significant data relating to organic compounds were obtained from the analysis of unconcentrated samples during either experiment. The cryogenically concentrated samples analyzed by gas chromatography, infrared spectrometry, and mass spectrometry yielded substantial information. The frequency and highest average concentration of cryogenically concentrated samples during the 27-day study are given in table I (ref 7). In the 27-day experiment 97 compounds were identified and 66 in the 56-day experiment (table II) (ref 1).

Thirty-nine compounds (table III) were reported during the 27-day experiment which were not reported during the 56-day study. Seven compounds (table IV) were reported during the 56-day study which had not been reported during the 27-day

TABLE I

FREQUENCY AND HIGHEST AVERAGE CONTAMINANT CONCENTRATION
DURING THE 27-DAY EXPERIMENT

COMPOUND BY CHEMICAL CLASS	ARNOLD		LOCKHEED		MELPAR		VON KARMAN	
	FREQ. * (mg/m ³)	HIGHEST CONC. (mg/m ³)	FREQ. * (mg/m ³)	HIGHEST CONC. (mg/m ³)	FREQ. * (mg/m ³)	HIGHEST CONC. (mg/m ³)	FREQ. * (mg/m ³)	HIGHEST CONC. (mg/m ³)
Inorganic Acids								
Hydrogen Fluoride (Unmanned)	11/11	0.5100						
(Manned)	14/14	1.3000						
Carbon Dioxide	11/11	930.0000	10/11	980.00000	10/10	410.00000	10/10	2400.00000
	14/14	6500.0000	13/14	6100.00000	14/14	14000.00000	14/14	5500.00000
Organic Acids								
Acetic Acid (Unmanned)							1/10	0.00130
(Manned)							7/14	0.00330
Propionic Acid							0/10	
							3/14	0.00270
Valeric Acid							0/10	
							5/14	0.00570
Alcohols								
Methyl (Unmanned)	11/11	0.3400			6/10	0.00630	5/10	0.04700
(Manned)	14/14	0.2700			5/14	0.03600	10/14	0.65000
Ethyl	9/11	0.0930		0.00130	10/10	0.16000	2/10	0.14000
	14/14	2.9000			13/14	0.04500	11/14	0.06000
Allyl					1/10	0.01600	1/10	0.00380
n-Propyl					6/14	0.02900	0/14	
							0/10	
iso-Propyl	9/11	0.4900		0.02400			0/14	
	14/14	7.8000			0/10		7/10	0.03300
					1/14	0.00730	8/14	0.03000

*Denominator of fraction indicates the number of samples of chamber atmosphere and numerator indicates positive identification of the corresponding compound.

TABLE I (CONT'D)

COMPOUND BY CHEMICAL CLASS	ARNOLD		LOCKHEED		MELPAR		VON KARMAN	
	HIGHEST CONC. (mg/m ³)	FREQ. * (manned)	HIGHEST CONC. (mg/m ³)	FREQ. * (manned)	HIGHEST CONC. (mg/m ³)	FREQ. * (manned)	HIGHEST CONC. (mg/m ³)	FREQ. * (manned)
Alcohols (Cont'd)								
Butyl (Unmanned)					0.01800	0/10		
iso-Butyl (Manned)					0.03000	0/14		
					0.00093	1/10	0.00250	
					0.00220	2/14	0.02000	
Aldehydes								
Acetaldehyde (Unmanned)	0.26000	0/11					0.03000	
Butyraldehyde (Manned)	0.34000	0/14					0.05200	
Aromatic Hydrocarbons								
Benzene (Unmanned)	0.16000	11/11	0.07000				0.08000	
	2.70000	13/14	0.06400				0.05400	
Toluene (Manned)	0.06900	10/11	0.07800		0.17000	9/10	0.38000	
	0.68000	12/14	0.05600		0.48000	14/14	0.05300	
Styrene								
o-Xylene	3.20000	10/11	0.02800		0.02400	8/10	0.57000	
Ethyl Benzene	0.04600	12/14	0.00780		0.02800	10/14	0.01400	
Pseudocumene								
Mesitylene								
Naphthalene								

TABLE I (CONT'D)

<u>COMPOUND BY CHEMICAL CLASS</u>	ARNOLD		LOCKHEED		MELPAR		VON KARMAN	
	<u>FREQ. *</u>	<u>HIGHEST CONC. (mg/m³)</u>	<u>FREQ. *</u>	<u>HIGHEST CONC. (mg/m³)</u>	<u>FREQ. *</u>	<u>HIGHEST CONC. (mg/m³)</u>	<u>FREQ. *</u>	<u>HIGHEST CONC. (mg/m³)</u>
<u>Aromatic Hydrocarbons (cont'd)</u>								
<u>Tetramethylbenzene (Unmanned)</u>								
<u>Methyl Naphthalene</u>								
<u>Dimethyl Naphthalene</u>								
<u>Amines</u>								
<u>Methyl Amine (Unmanned)</u>								
<u>(Manned)</u>								
<u>Esters</u>								
<u>Methyl Acetate (Unmanned)</u>								
<u>(Manned)</u>								
<u>Ethyl Formate</u>								
<u>Ethyl Acetate</u>								
<u>n-Propyl Acetate</u>								
<u>Methyl n-Butyrate</u>								
<u>Butyl Acetate</u>								
<u>Ethers</u>								
<u>Furan (Unmanned)</u>								

TABLE I (CONT'D)

COMPOUND BY CHEMICAL CLASS	ARNOLD		LOCKHEED		MELPAR		VON KARMAN	
	HIGHEST CONC. (mg/m ³)	FREQ. * (mg/m ³)	HIGHEST CONC. (mg/m ³)	FREQ. * (mg/m ³)	HIGHEST CONC. (mg/m ³)	FREQ. * (mg/m ³)	HIGHEST CONC. (mg/m ³)	FREQ. * (mg/m ³)
Ethers (cont'd)								
Tetrahydrofuran (Unmanned)	2.3000	2/11					0.57000	8/10
(Manned)	0.4400	7/14					0.60000	13/14
Ethyl Ether			0.01000	2/10	0.04000	2/10	0.14000	9/10
Methyl Furan			1.00000	8/14	1.40000	8/14	0.34000	9/14
							0.02600	2/10
							0.00018	2/14
Dioxane			0.01200					
			0.01500					
Dimethyl Furan								
iso-Propyl Ether							0.00033	0/10
								3/14
1, 4-Dimethoxybenzene			0.00020					
Benzyl Ether							0.00370	0/10
								1/14
								0/10
								1/14
Halogen Derivatives of Aromatic and Cyclic Hydrocarbons								
Chlorobenzene (Unmanned)					0.00330	3/10		0/10
(Manned)					0.00220	2/14		0/14
Halogen Derivatives of Ethane								
1, 2-Dichloroethane (Unmanned)	0.0370	5/11					0.07300	6/10
(Manned)	0.2500	11/14					0.00250	2/14
1, 1-Dichloroethane	0.0260	7/11						
	0.0950	13/14						
Pentafluoroethane								
								0/10
								7/14
								0.02300

TABLE I (CONT'D)

COMPOUND BY CHEMICAL CLASS	ARNOLD		LOCKHEED		MELPAR		VON KARMAN	
	FREQ.*	HIGHEST CONC. (mg/m ³)	FREQ.*	HIGHEST CONC. (mg/m ³)	FREQ.*	HIGHEST CONC. (mg/m ³)	FREQ.*	HIGHEST CONC. (mg/m ³)
Halogen Derivatives of Ethane (cont'd)								
Methyl Chloroform (Unmanned)	1/11	0.0500			6/10	0.00470	1/10	0.01900
Freon 114	0/14				3/14	0.00076	5/14	0.05800
Freon 113							5/10	0.00530
							11/14	0.28000
							0/10	
							1/14	0.02000
Halogen Derivatives of Ethylene								
Vinyl Chloride (Unmanned)	2/11	0.0210					0/10	
(Manned)	0/14				7/10	0.03000	0/14	
1, 1-Dichloroethylene	4/11	0.0800			9/14	0.01000	0/14	
	3/14	0.0021					7/10	0.03100
Trichloroethylene	0/11						0/14	
	1/14	0.0380			3/10	0.00110	9/10	0.13000
Perchloroethylene	8/11	36.0000			3/14	0.00810	9/14	0.083000
	8/14	0.0440			0/10		0/10	
					4/14	0.02900	0/14	
Halogen Derivatives of Methane								
Methyl Chloride (Unmanned)	0/11						0/10	
(Manned)	0/14				0/10	0.00420	0/14	
Methylene Chloride	6/11	0.0300			0/14	0.01100	0/14	
	3/14	0.1900			5/10	0.01100	6/10	0.10000
Freon 22	0/11				1/14	0.03100	11/14	0.05000
	0/14				0/10		0/10	
Chloroform	4/11	0.0780			0/14		0/14	
	3/14	510.0000			6/10	0.11000	2/10	0.02800
Freon 11	10/11	11.0000			13/14	1.90000	11/14	0.88000
	13/14	10.0000			7/10	0.03700	10/10	0.18000
					10/14	1.33000	12/14	0.30000

TABLE I (CONT'D)

COMPOUND BY CHEMICAL CLASS	ARNOLD		LOCKHEED		MELPAR		VON KARMAN	
	HIGHEST CONC. (mg/m ³)	FREQ. * (mg/m ³)	HIGHEST CONC. (mg/m ³)	FREQ. * (mg/m ³)	HIGHEST CONC. (mg/m ³)	FREQ. * (mg/m ³)	HIGHEST CONC. (mg/m ³)	FREQ. * (mg/m ³)
Halogen Derivatives of Methane (cont'd)								
Carbon Tetrachloride (Unmanned)	0.1600	8/11	0/11	0/11	0/10	0/10	0.08300	4/10
	0.0530	3/14	0/14	0/14	0/14	0/14	0.00010	2/14
Indoles								
Skatole	(Unmanned)	0/11	0/11	0/11	0/10	0/10		0/10
	(Manned)	0/14	0/14	0/14	0/14	0/14		8/14
Ketones								
Acetone	(Unmanned)	10/11	11/11	11/11	9/10	9/10	0.11000	10/10
	(Manned)	14/14	13/14	13/14	13/14	13/14	0.33000	14/14
Methyl Ethyl Ketone		4/11	0/11	0/11	10/10	10/10	0.02600	7/10
		13/14	0/14	0/14	14/14	14/14	0.01600	12/14
Methyl iso-Butyl Ketone		0/11	0/11	0/11	0/10	0/10	0.01600	5/10
		0/14	0/14	0/14	0/14	0/14	0.05700	4/14
Naphthenes								
Cyclopropane	(Unmanned)		2/11	2/11	0.01100	0.01100		0/10
	(Manned)		3/14	3/14	0.00970	0.00970		0/14
Cyclohexane			6/11	6/11	0.03300	0.03300		2/10
			8/14	8/14	0.00600	0.00600		5/14
Methyl Cyclohexane			7/11	7/11	0.00200	0.00200		3/10
			1/14	1/14	0.00150	0.00150		5/14
Dimethyl Cyclopentane			0/11	0/11				5/10
			0/14	0/14				1/14
Dimethyl Cyclohexane								6/10
								8/14
Indene								4/10
								0/14

TABLE I (CONT'D)

<u>COMPOUND BY CHEMICAL CLASS</u>	ARNOLD		LOCKHEED		MELPAR		VON KARMAN	
	HIGHEST CONC	FREQ. * (mg/m ³)	HIGHEST CONC	FREQ. * (mg/m ³)	HIGHEST CONC	FREQ. * (mg/m ³)	HIGHEST CONC	FREQ. * (mg/m ³)
<u>Naphthenes (cont'd)</u>								
<u>Decalin</u>	(Unmanned)							
	(Manned)							
<u>Decalin Isomers</u>								
<u>Paraffins</u>								
<u>Methane</u>	(Unmanned)							
	(Manned)							
<u>Ethane</u>		0/11						
		0/14						
		1/11						
		0/14						
<u>Propane</u>		1/11						
		0/14						
<u>Butane</u>								
<u>iso-Butane</u>								
<u>Pentane</u>								
<u>iso-Pentane</u>								
<u>Hexane</u>								
<u>2, 2-Dimethyl Butane</u>								
<u>2, 3-Dimethyl Butane</u>								
<u>Heptane</u>								

TABLE I (CONT'D)

COMPOUND BY CHEMICAL CLASS	ARNOLD		LOCKHEED		MELPAR		VON KARMAN	
	FREQ. *	HIGHEST CONC. (mg/m ³)	FREQ. *	HIGHEST CONC. (mg/m ³)	FREQ. *	HIGHEST CONC. (mg/m ³)	FREQ. *	HIGHEST CONC. (mg/m ³)
Paraffins (cont'd)								
<u>iso-Octane</u>								
(Unmanned)								
(Manned)								
Sulfides								
Hydrogen Sulfide								
(Unmanned)	9/11	0.7300						
(Manned)	8/14	0.9600						
Sulfur Compounds								
<u>Propyl Mercaptan</u>								
(Unmanned)								
(Manned)								
Olefins								
<u>Ethylene</u>								
(Unmanned)	0/11							
(Manned)	4/14	0.0270						
Propylene								
(Unmanned)	4/11	0.0010						
(Manned)	1/14	0.0027						
(Unmanned)	10/11	0.0240						
(Manned)	7/14	0.0240						
1-Butene								
(Unmanned)	8/11	0.0100						
(Manned)	10/14	0.0150						
2-Butene (cis)								
(Unmanned)	0/11							
(Manned)	3/14	0.0820						
2-Butene (trans)								
(Unmanned)	1/11	0.0011						
(Manned)	5/14	0.0058						
iso-Butylene								
(Unmanned)	9/11	0.0100						
(Manned)	8/14	0.0080						
1-Pentene								
(Unmanned)	0/11	0.0035						
(Manned)	1/14							

TABLE I (CONT'D)

COMPOUND BY CHEMICAL CLASS	ARNOLD		LOCKHEED		MELPAR		VON KARMAN	
	FREQ. *	HIGHEST CONC. (mg/m ³)	FREQ. *	HIGHEST CONC. (mg/m ³)	FREQ. *	HIGHEST CONC. (mg/m ³)	FREQ. *	HIGHEST CONC. (mg/m ³)
Halogen Derivatives of Higher Aliphatic Hydrocarbons								
Propyl Chloride (Unmanned)					10/10	0.02000		
					6/14	0.05400		
Diolfins								
Allene (Unmanned)			0/11					
			3/14	0.0140				
			1/11	0.0031				
1, 3-Butadiene			4/14	0.0070				
Isoprene			0/11				1/10	0.00490
			0/14				13/14	0.65000
Acetylenes								
Acetylene (Unmanned)			6/11	0.0280				
			1/14	0.0011				
Propyne			1/11	0.0018				
			1/14	0.0064				
Cycloolefins								
Cyclohexene (Unmanned)			3/11	0.0040				
			9/14	0.0060				

TABLE II

TRACE CONTAMINANTS ISOLATED FROM THE TEST CELL
ATMOSPHERE DURING THE 56-DAY STUDY

COMPOUND	FREQUENCY [†]	HIGHEST	ACGIH* TLV
		CONCENTRATION (mg/m ³ x 10 ⁻³)	100 (mg/m ³ x 10 ⁻³)
<u>Alcohols</u>			
Allyl Alcohol	4/18	4.5	50
n-Butyl Alcohol	4/18	17.0	3000
iso-Butyl Alcohol	2/18	1.0	***
Ethyl Alcohol	13/18	46.0	19000
Methyl Alcohol	9/18	125.0	2600
n-Propyl Alcohol	4/18	33.0	***
iso-Propyl Alcohol	8/18	85.0	9800
<u>Aldehydes</u>			
Acetaldehyde	3/18	2.7	3600
Butyraldehyde	6/18	35.0	***
<u>Aromatic Hydrocarbons</u>			
Benzene	14/18	61.0	800
Ethyl Benzene	4/18	3.5	4350**
Naphthalene	2/18	9.3	500**
Toluene	16/18	85.0	7500
Xylene	10/18	122.0	4350**
<u>Halogen Derivatives of Aromatic Hydrocarbon</u>			
Chlorobenzene	9/18	29.0	3500
<u>Halogen Derivatives of Ethane</u>			
1,2-Dichloroethane	4/18	8.6	2000
Freon 113	5/18	3.3	***
Freon 114	8/18	11.0	70000
Methyl Chloroform	2/18	16.0	19000
Pentafluoroethane	2/18	60.0	***
<u>Halogen Derivatives of Ethylene</u>			
Perchloroethylene	7/18	18.0	6700
Trichloroethylene	9/18	14.0	5200
Vinyl Chloride	3/18	53.0	13000

[†]Numerator is number of times compound was reported; denominator is number of samples taken.

*Threshold Limit Value for 1965, adopted at 27th Annual Meeting of American Conference of Governmental Industrial Hygienists, Houston, Texas, May 1965.

**Tentative Value ACGIH, 1965.

***Value not established.

TABLE II (CONT'D)

COMPOUND	FREQUENCY [†]	HIGHEST	ACGIH* TLV
		CONCENTRATION (mg/m ³ x 10 ⁻³)	100 (mg/m ³ x 10 ⁻³)
<u>Halogen Derivatives of Methane</u>			
Carbon Tetrachloride	7/18	36.0	650
Chloroform	4/18	41.0	2400
Freon 11	8/18	210.0	56000
Freon 22	2/18	5600.0	***
Methylene Chloride	7/18	36.0	17500
<u>Ketones</u>			
Acetone	14/18	140.0	24000
2-Methyl Butanone-3	1/18	3.7	***
Methyl iso-Butyl Ketone	6/18	27.0	4100
Methyl Ethyl Ketone	12/18	590.0	5900
<u>Naphthenes</u>			
Cyclohexane	13/18	35.0	10500
Decalin	7/18	330.0	***
Dimethyl Cyclohexane	2/18	2.4	***
Methyl Cyclohexane	4/18	5.6	20000
<u>Paraffins</u>			
2,2-Dimethyl Butane	6/18	4.2	***
2,3-Dimethyl Butane	1/18	0.032	***
Heptane	1/18	120.0	20000
Hexane	3/18	81.0	18000
2-Methyl Pentane	1/18	0.042	***
Octane	2/18	58.0	23500
Pentane	2/18	53.0	29500
iso-Pentane	7/18	8.5	***
<u>Esters</u>			
Amyl Acetate	1/18	14.0	5250
iso-Butyl Acetate	4/18	16.0	7000**
Ethyl Acetate	7/18	15.0	14000
Ethyl Formate	2/18	0.39	3000
Methyl Acetate	6/18	4.2	6100
Methyl n-Butyrate	7/18	3.7	***
Methyl Methacrylate	4/18	3.8	4100
n-Propyl Acetate	3/18	15.0	8400
<u>Ethers</u>			
Dimethyl Furan	1/18	0.84	***
Ethyl Ether	9/18	24.0	12000
Furan	2/18	1.2	***
Methyl Furan	3/18	16.0	***
iso-Propyl Ether	1/18	24.0	21000
Tetrahydrofuran	4/18	14.0	5900

TABLE II (CONT'D)

COMPOUND	FREQUENCY [†]	HIGHEST	ACGIH* TLV
		CONCENTRATION (mg/m ³ x 10 ⁻³)	100 (mg/m ³ x 10 ⁻³)
<u>Sulfur Compounds</u>			
Dimethyl Sulfide	1/18	0.47	***
Ethyl Mercaptan	4/18	35.0	250**
Methyl Mercaptan	1/18	23.0	200**
Propyl Mercaptan	3/18	1.3	***
<u>Olefins</u>			
Ethylene	9/18	19.0	***
Propylene	8/18	25.0	***
<u>Diolefin</u>			
Isoprene	8/18	4.4	***
<u>Halogen Derivatives of Higher Aliphatic Hydrocarbons</u>			
Propyl Chloride	1/18	1.5	***

TABLE III

COMPOUNDS IDENTIFIED AND QUANTITATED ONLY IN 27-DAY STUDY

Acetic Acid	Decalin Isomers	Methane
Acetylene	1, 1-Dichloroethylene	Methylamine
Allene	1, 4-Dimethoxybenzene	Methylchloride
Benzyl Ether	Dimethyl Cyclopentane	Methyl Naphthalene
1, 3-Butadiene	Dimethyl Naphthalene	1-Pentene
Butane	Dioxane	Propane
iso-Butane	Ethane	Propionic Acid
1-Butene	Hydrogen Fluoride	Propyne
2-Butene (Cis)	Hydrogen Sulfide	Pseudocumene
2-Butene (Trans)	Indene	Skatole
Butyl Acetate	iso-Butylene	Styrene
Cyclohexene	iso-Octane	Tetramethyl Benzene
Cyclopropane	Mesitylene	Valeric Acid

TABLE IV

COMPOUNDS IDENTIFIED AND QUANTITATED ONLY IN 56-DAY STUDY

Amyl Acetate	2-Methyl 3-Butanone
Dimethyl Sulfide	Methyl Mercaptan
Ethyl Mercaptan	Methyl Methacrylate
	Octane

study. Fifty-eight compounds were reported for both experiments. One compound, 4-methyl-pentane, was reported only for the preexperimental stabilization period of the 27-day study.

DISCUSSION

In a discussion of atmospheric contaminants, mg/m^3 is the most useful term to express concentration, due to the various total pressures at which experiments are conducted. This becomes significant when physiological equivalence is being discussed in relation to the concentration of a contaminant.

An increase in carbon monoxide was apparent in both studies. It showed the greatest increase as the result of including man in the system. This would be of particular concern in long duration studies with minimum gas leakage owing to its physiologic effect.

The literature indicates a carbon monoxide production of 0.30 ml/man/hr from the destruction of erythrocytes and a measured carbon monoxide production of 0.42 ml/man/hr (ref 3, 4, 14). The production of carbon monoxide during the manned portion of the 27-day study was about the same, being 0.37 ml/man/hr at 0 C and 760 mm Hg (ref 7).

The volunteers used in the 27-day study were found to be the primary methane producers (ref 10), since the amount produced was consistent with that possible from flatus. Of the 97 compounds reported during the 27-day experiment, 22 (table V) were not identified in the unmanned portion.

Carbon dioxide is a representative compound of a contaminant produced by man which demonstrates an increase when the man is included in a sealed environmental system. Similar patterns were demonstrated by methyl alcohol, acetone, ethyl ether, and isoprene.

The compounds that showed a consistent or decreasing concentration were toluene, Freon 11, methyl ethyl ketone, hexane, and xylene. These compounds are indicative of solvents used in the chamber (ref 6) as well as those compounds added from the supply gases (table VI).

Naphthalene was present in the chamber as a residual from the mothproofing of the blankets. Decalin appeared soon after the men entered the chamber. Decalin has a similar structure to naphthalene except that it has a saturated ring structure, which suggests modification of structure by the human system.

Styrene was the one compound reported only during the unmanned portion of the study. The source was probably from operational equipment within the chamber, which had styrene polymer as a component.

The 68 compounds identified and quantitated during the 56-day experiment (table II) appear well below the level of toxicity when compared with values of the American Conference of Governmental Industrial Hygienists (ACGIH) threshold limit values reduced by a factor of 0.01. The reduction, while not documented nor justified, provides an index for comparison (ref 1). The highest concentrations

were 2 to 3 times less than the cited reduction of the ACGIH values, which indicate that trace contaminants were not a critical nor limiting factor in this study (ref 1).

TABLE V

A CHEMICAL CLASS LISTING OF COMPOUNDS IDENTIFIED AND QUANTITATED ONLY DURING THE MANNED PORTION OF THE 27-DAY EXPERIMENT

<u>ORGANIC ACIDS</u>	<u>INDOLE</u>
Propionic Acid	Skatole
Valeric Acid	
<u>ALDEHYDES</u>	<u>NAPHTHENES</u>
Butyraldehyde	Decalin
	Decalin Isomers
<u>AROMATIC HYDROCARBONS</u>	<u>PARAFFINS</u>
Mesitylene	Methane
<u>ESTERS</u>	<u>SULFUR COMPOUNDS</u>
Methyl n-Butyrate	Propyl Mercaptan
Butyl Acetate	
<u>ETHERS</u>	<u>OLEFINS</u>
Furan	2-Butene (cis)
1,4-Dimethoxybenzene	1-Pentene
Benzyl Ether	
Dimethyl Furan	<u>DIOLEFINS</u>
iso-Propyl Ether	Allene
<u>HALOGEN DERIVATIVES OF ETHANE</u>	<u>AMINES</u>
Freon 113	Methyl Amine
Pentafluoroethane	

TABLE VI

CONTAMINANTS IN SUPPLY GASES
(27-DAY CONTAMINANT STUDY AT 760 mm Hg)

COMPOUND BY CHEMICAL CLASS	CONTENT IN OXYGEN mg/m ³	CONTENT IN NITROGEN mg/m ³
<u>ORGANIC ACIDS</u>		
Acetic Acid		0.0012
Propionic Acid		0.00042
<u>ALCOHOLS</u>		
Methyl Alcohol	0.00076	
Ethyl Alcohol	0.084	

COMPOUND BY CHEMICAL CLASS	CONTENT IN OXYGEN mg/m ³	CONTENT IN NITROGEN mg/m ³
<u>AROMATIC HYDROCARBONS</u>		
Benzene		0.0062
Toluene	0.00038	
o-Xylene		0.011
Pseudocumene		0.0033
Mesitylene		0.042
Naphthalene		0.00042
<u>ESTERS</u>		
Methyl Acetate		0.0025
Butyl Acetate		0.00025
Methyl n-Butyrate		0.0021
<u>ETHERS</u>		
Tetrahydrofuran		0.036
Ethyl Ether	0.000059	
Isopropyl Ether	0.00097	
<u>HALOGEN DERIVATIVES OF ETHANE</u>		
Methyl Chloroform	0.00020	
Freon 114		0.0012
<u>HALOGEN DERIVATIVES OF ETHYLENE</u>		
Vinyl Chloride	0.0025	
Methyl Chloroform		0.0042
Trichloroethylene		0.0042
<u>HALOGEN DERIVATIVES OF METHANE</u>		
Methylene Chloride		0.00042
Chloroform	0.040	
Freon 22	0.00050	
<u>INDOLES</u>		
Skatole		0.00042
<u>KETONES</u>		
Acetone	0.0055	0.0050
Methyl Ethyl Ketone	0.0063	0.00021
<u>NAPHTHENES</u>		
Cyclohexane		0.000042
Methyl Cyclohexane		0.00021
Dimethylcyclohexane		0.00083
Decalin		0.00083
Indene		0.000042

COMPOUND BY CHEMICAL CLASS	CONTENT IN OXYGEN mg/m ³	CONTENT IN NITROGEN mg/m ³
<u>PARAFFINS</u>		
Ethane	0.00034	
Hexane	0.00020	0.000042
Isopentane		0.000083
2, 3-Dimethyl Butane		0.000042
<u>OLEFINS</u>		
Ethylene		0.00025
<u>DIOLEFINS</u>		
Isoprene		0.0010

SUMMARY

The atmospheres to which four human subjects were exposed for 14 days at 760 mm Hg and 56 days at 258 mm Hg were analyzed for trace contaminants. A total of 105 compounds were detected. The concentration of these compounds remained below a level thought to cause a physiologic effect (ref 1). Carbon monoxide and carbon dioxide were the only compounds which were produced by man at such a rate that clearly would require removal in long-term sealed atmospheric habitation. The methods used for contaminant analyses have demonstrated their usefulness in the experimental programs being conducted at the USAF School of Aerospace Medicine.

ACKNOWLEDGMENT

The research reported in this paper was conducted by personnel of the Environmental Systems Branch, USAF School of Aerospace Medicine, Aerospace Medical Division, AFSC, United States Air Force, Brooks Air Force Base, Texas. This work was supported in part by NASA Manned Spacecraft Center (NASA Contract R-89).

The author wishes to express his appreciation for the assistance rendered by B. E. Welch, Ph.D., Chief, Environmental Systems Branch, and Dr. E. Harris, NASA Manned Spacecraft Center, Houston, Texas. Appreciation is also expressed to Mr. Neil Kaiser and 2nd Lt. Patricia H. Wolf for data reduction. The voluntary informal consent of the subjects used in this research was obtained as required by Air Force Regulation 169-8.

REFERENCES

1. Adams, J. D., Conkle, J. P., Mabson, W. E., Watson, J. T., Wolf, P. H., and Welch, B. E.: The Study of Man During a 56-Day Exposure to an Oxygen-Helium Atmosphere at 258 mm Hg Total Pressure: II. Major and Minor Atmospheric Components. Aerospace Med. In Press.
2. Chaudet, J., and deSchmertzing, H.: Utilization of Infrared Spectrophotometry in Microcontaminant Studies in Sealed Environments. Final Formal Report, Contract No. AF 41(609)-1962, Melpar, Inc., Falls Church, Virginia, 31 August 1965.
3. Coburn, R. F., Blakemore, W. S., and Forster, R. E.: Endogenous Carbon Monoxide Production in Man. J. Clin. Invest., 42:1172, 1963.
4. Coburn, R. F., Williams, W. J., and Forster, R. E.: Effect of Erythrocyte Destruction on Carbon Monoxide Production in Man. J. Clin. Invest., 43:1098, 1964.
5. Conkle, J. P., Register, J. W., and Worth, G. L.: Multistage Cryogenic Trapping System. Aerospace Med., 36:869, 1965.
6. Conkle, J. P.: "Sampling and Analysis of Atmospheric Contaminants". In Proceedings of the Conference on Atmospheric Contamination in Confined Spaces, 30 March - 1 April 1965. AMRL TR-65-230, Aerospace Medical Research Laboratories, Wright-Patterson Air Force Base, Ohio, December 1965.
7. Conkle, J. P., Mabson, W. E., Adams, J. D., Zeft, H. J., and Welch, B. E.: A Detailed Study of Contaminant Production in a Space Cabin Simulator at 760 mm Hg. Presented at 37th Annual Meeting, Aerospace Medical Association, Las Vegas, Nevada, April 1966.
8. Hargreaves, J. J., Robertson, W. G., Ulvedal, F., Zeft, H. J., and Welch, B. E.: The Study of Man During a 56-Day Exposure to an Oxygen-Helium Atmosphere at 258 mm Hg Total Pressure: I. Introduction and General Experimental Design. Aerospace Med. In Press.
9. Heidelbaugh, N. D., Vanderveen, J. E., Klecka, M., and O'Hara, M. J.: The Study of Man During a 56-Day Exposure to an Oxygen-Helium Atmosphere at 258 mm Hg Total Pressure: Nutritional Requirements. Aerospace Med. In Press.
10. Kirk, E.: The Quantity and Composition of Human Colonic Flatus. Gastroenterology, 12:782, 1949.
11. Moberg, M. L.: Analysis of Trace Contaminants in Closed Ecological Atmospheres. Final Report No. 3073, Contract No. AF 41(609)-2783, Aerojet-General Corporation, Azusa, California, September 1965.

REFERENCES (CONT'D)

12. Rinehart, R. W., Honma, M., Tuttle, W. N., Nygren, R. E., Flowers, O. L., and Jensen, L. B.: Final Report on Program for Delineation of Trace Constituents of a Closed Ecological System, Contract AF 41(609)-2788, Lockheed Missiles and Space Company, Sunnyvale, California, July 1965.
13. Sherrell, F. G., and Baltz, J. A.: A Trace Contaminant Analysis Test on Air Samples. AEDC-TR-66-42, Arnold Engineering Development Center, Arnold Air Force Station, Tennessee, March 1966.
14. Sjostrand, T.: Endogenous Formation of Carbon Monoxide in Man Under Normal and Pathological Conditions. Scand. J. Clin. Lab. Invest., 1:201, 1949.

DISCUSSION

DR. DOST (Oregon State University): Are those values representing differences from the similar operations of a controlled system for 14 days or are they direct?

MR. CONKLE: The conversions have been made. Those values in the first tables are the highest concentration. The upper value was the unmanned portion which was the background period and then by inserting man into the system we had the second value, the one underneath.

DR. DOST: Did you monitor methane?

MR. CONKLE: Yes, we did. The individuals that were used in the 27-day experiment were determined to be methane producers after the methane occurred. The methane concentration increased as did the carbon monoxide and the rate of production was approximately 2.05 ml per man per hour.

MR. WILLARD (Honeywell Aeronautical Division): Did you have any list of the materials used in the chamber itself?

MR. CONKLE: No, we got this chamber a few years ago. We have redone certain areas of the chamber. We know some of the materials. Last year we recorded the solvents that were found in our paints. In the 56-day experiments, as an example, methyl methacrylate showed up rather suddenly and it was determined that about the time the methyl methacrylate showed up, they put in a spirometer which has a large Plexiglass dome on it.

DR. SCHAEFER (U. S. Naval Medical Research Laboratory): Can you explain the decrease of toluene, methyl ketone and xylene in the manned portion?

MR. CONKLE: Yes. Originally we had a high concentration because the first 2 days shown on the slide were in an enclosed system. The chamber was then taken to 156 mm oxygen, flushed, and then brought back up to altitude. We have evidently had some removal during this oxygen flush period and also there is work to be done in the area of lithium hydroxide scrubbed and water condensation systems which may be taking some contaminants out of the chamber atmosphere.

DR. COSTA (Roswell Park Memorial Institute): How did you identify carbon monoxide? Did you do it by mass spectrometry and, if so, is it possible that this is simply a breakdown of the carbon dioxide in large concentration? In mass spectrometry you see a peak of 28 which is probably an artifact.

MR. CONKLE: No, sir, it was done with infrared spectrometry. We used two instruments on a batch and stream basis, a Lira 300 carbon monoxide analyzer and a Beckman IR-7 using a specific peak around 4 microns. We used the Lira 300 on a constant monitoring basis, and we checked the 300 data against the IR-7 on a batch basis.

FROM THE FLOOR: Were any of the men smokers before they went into the chamber?

MR. CONKLE: Yes, sir, but they had been off smoking so their carbon monoxide levels would have dropped. We have also seen this in cases of non-smokers.

FROM THE FLOOR: Well, I was just wondering about the acetonitrile that smokers give off for quite a while. Was that detectable?

MR. CONKLE: I don't remember.

FROM THE FLOOR: I would like to ask whether you have any idea already about physiological changes in any system that would be attributed to the condition of the chamber or to the substances you tested?

MR. CONKLE: No, sir, I do not. This is an area which I would prefer that the physicians and the physiologists within our group would answer. They may get together with us at a later time and we'll discuss it.

A DANGEROUS CLOSED ATMOSPHERE TOXICANT, ITS SOURCE AND IDENTITY

Raymond A. Saunders

U. S. Naval Research Laboratory
Washington, D. C.

A lot of effort has been expended in identifying the various trace organic contaminants which develop in closed environmental atmospheres and in determining the toxicity of those contaminants. The purpose, of course, is to permit the design of adequate contaminant control systems to maintain such atmospheres as pure and habitable as possible. Generally, these atmospheres stay that way -- tolerably pure and habitable -- and it's a rare and important event when a closed environmental atmosphere becomes uninhabitable because of organic contamination.

A notable incident involving such contamination, to a degree which actually led to a mission abort, was described in Missiles and Rockets magazine in January 1964. This incident involved a Manned Environmental Systems Assessment -- Project MESA, for short.

The MESA experiments were the first to evaluate a completely integrated and regenerative air, water, and biological life support system. The purpose of the tests was to determine the effectiveness of the system by maintaining five men in a completely closed system for 30 days.

Naturally, many secondary experiments were scheduled which required a lot of extra equipment in the chamber in addition to the life support system. The chamber also contained all of the food and other supplies required to maintain the five-man crew for 30 days. Much of all these materials were organic, of course, and, as such, were recognized as potential sources of atmospheric contaminants.

The essential elements of the air contaminant control system were charcoal and silica gel adsorbent beds, a Hopcalite catalytic oxidizer and lithium hydroxide and sodium superoxide units. The latter unit removed carbon dioxide, adsorbed acid gases, and regenerated oxygen.

A preliminary 2-day unmanned test of the entire system was successfully completed without difficulty before the start of the manned test. Like many complicated experiments, however, the first attempt at the main event was plagued with difficulties.

To name a few, electrical insulation on a pair of heater leads charred and evolved a disagreeable odor; neoprene ducting carrying heated gases between units of the air purification system also emitted an unpleasant odor; several mechanical difficulties were encountered with the biological waste reactor which forced on the crew the unpleasant task of periodic cleanings of the unit in situ. None of these events had any effect on the situation as it later developed, however, except to add to the complexity of the problem.

Parts of the sodium superoxide unit were fabricated from aluminum. The action of atmospheric moisture on the superoxide resulted in a solution of sodium hydroxide wetting some of the aluminum parts and the subsequent evolution of hydrogen. The steady evolution of hydrogen into the atmosphere necessitated passing the chamber air through the Hopcalite catalyst burner at a rate faster than planned. The increased flow rate through the catalytic oxidizer exceeded its design rate and dropped the temperature of the catalyst bed considerably below its desired operating temperature. Studies of the Hopcalite-catalyzed combustion of organic atmospheric contaminants made at the Naval Research Laboratory have shown a not-surprising decrease in combustion for less-than-optimum catalyst temperatures. Some contaminants are completely decomposed, but with low efficiency, while others, such as certain chlorinated hydrocarbons, are only partially decomposed, with the formation of intermediate decomposition products.

As a result of the lowered efficiency of the catalytic oxidizer in the MESA chamber, the atmospheric contaminant load increased fairly rapidly. In less than forty-eight hours the atmosphere acquired a very distinct and sickening sour-sweet odor which became increasingly irritating to the crew. The crew soon lost their appetites and their general feeling of well-being began to deteriorate.

After the third and fourth day of exposure to the chamber atmosphere, the crew's nausea progressed to vomiting; the men developed itchiness around the eyes, headaches, sore gums, and painful jaws. To further compound the crew's discomfort, the glass in the sight gauge of the sewage tank burst and raw sewage spilled across the chamber floor. The crew, already feeling considerably sub-par, at this point elected to abort the test in the middle of the fourth day.

The symptoms experienced by the MESA crew are listed in table I. All of these were thought to be caused by atmospheric contamination by medical personnel in attendance. Oddly, the crew developed rather severe cold sores shortly after the test abort. These were also attributed by test personnel to chemical irritation in the chamber atmosphere and not to viral infection. Two of the other symptoms, the itchy eyes and the pains in the gums and jaws, are also rather unusual. All of these rather strange symptoms persisted for several days before finally subsiding.

TABLE I

MESA SYMPTOMS

Loss of Appetite
Extreme Nausea
Vomiting
Itchiness around the Eyes
Soreness of Gums
Intense Pain in the Upper Jaw
Headaches
Welts on Mouth and Lips

Naturally, there was a great deal of interest in the identity and source of the causative agent. Many samples were taken from various points in the chamber and

sent to several laboratories for analysis. A 60-gram sample of charcoal was received at the Naval Research Laboratory. This sample had been exposed in the chamber for 48 hours following the abort, but during a time when the odor in the chamber was still strong. The desorbant mixture from that charcoal was resolved into its individual components with a vapor phase chromatograph. Each separated component was collected individually from the effluent stream and subsequently identified by means of its infrared or mass spectrum.

The various contaminants recovered from the charcoal are listed in table II. Except for two, these compounds are common and have been found many times before in other environmental atmospheres. The most prevalent trace contaminant in the MESA atmosphere was trichloroethylene. It was later recalled that this solvent had been used in the chamber for cleaning purposes prior to the start of the manned test. The two uncommon compounds found were mono- and dichloroacetylene. Neither of these compounds has ever been found before in a closed atmosphere.

TABLE II

CONTAMINANTS IDENTIFIED IN MESA ATMOSPHERE

Trichloroethylene	Ethyl Chloride
Dichloroacetylene	Carbon Disulfide
Monochloroacetylene	Vinylidene Chloride
Carbon Dioxide	Freon-12
N-Pentane	Ammonia
Ethanol	Methyl Chloride
Acetaldehyde	Ethyl Ether
Carbonyl Sulfide	2 Methyl Butene
Propylene	Acetone
N-Butane	Methanol
Isobutylene	Methyl Ethyl Ketone
Isopentane	

Since both of these compounds were known from the chemical literature to be extremely unstable in air, their presence in the MESA atmosphere was reported at first as questionable. The possibility existed that those compounds might have resulted from the thermal decomposition of other chlorinated hydrocarbons during the analytical procedures. Furthermore, no information concerning the toxicity of either of these compounds could be found in the literature usually available to scientists and engineers. Consequently, mono-, and dichloroacetylene were not at first seriously considered as a probable reason for the MESA symptoms. No further information developed concerning the MESA atmosphere, and the problem of pinpointing the cause of their trouble went unsolved until recently.

A few months ago, dichloroacetylene was detected at very low concentration in one of our nuclear submarine atmospheres. In this instance the compound was found in a sample of compressed air and was determined to be real and not an analytical artifact. The compound is obviously stable in air at low concentration.

Dichloroacetylene can be synthesized by passing trichloroethylene over any of several alkaline materials at a temperature above 70 C. When the compound was synthesized, it did indeed decompose explosively at high concentrations, yielding carbon monoxide and phosgene, but it was stable at low concentrations. High concentrations decompose in air but leave a low residual concentration. The stable concentration depends upon purity. There are many compounds which will inhibit this decomposition reaction, including trichloroethylene. Concentrations of dichloroacetylene in air as high as 200 ppm have been found stable in the presence of such compounds.

The toxicity of dichloroacetylene is well documented in the British medical literature. British physicians have reported a number of fatalities attributed to dichloroacetylene poisoning. The compound was encountered by patients who were being anesthetized with trichloroethylene when the anesthetic mixture was administered with a machine which incorporated a soda-lime carbon dioxide adsorber. The soda-lime became hot enough to convert trichloroethylene to dichloroacetylene as a result of reaction with the moisture and carbon dioxide in the patient's expired breath. Anesthetic mixtures containing as little as 1% trichloroethylene in air or oxygen were reported to have given rise to lethal concentrations of dichloroacetylene when administered in this fashion. Fatalities were reported which followed exposures as short as forty-five minutes. Unfortunately, the concentrations of toxic material which were inspired by these patients were not determined, but they were certainly limited in the presence of oxygen.

The symptoms of dichloroacetylene poisoning are unusual and unique. A comparison of the symptoms induced by dichloroacetylene and those exhibited by the MESA crew are presented in table III. Note that the correspondence between the two sets of symptoms is exact. This compound has a pronounced effect upon the trigeminal nerves of the face, and, with sufficient exposure, gives rise to an outbreak of herpetiform lesions or cold sores about the mouth. The symptoms develop with increasing exposure in the order listed. The long-lasting effect of the symptoms exhibited by the MESA crew was also noted by the British as being characteristic of dichloroacetylene poisoning. Incidentally, the dichloroacetylene prepared at NRL had a disagreeable sour-sweet odor, an odor which was also noted by the British and one which was particularly annoying in the MESA chamber.

TABLE III

<u>MESA SYMPTOMS</u>	<u>EFFECTS OF DICHLOROACETYLENE</u>
Loss of Appetite	Loss of Appetite
Extreme Nausea	Extreme Nausea
Vomiting	Vomiting
Itchiness around the Eyes	Symptoms Invo'ving Facial Muscles
Soreness of Gums	
Intense Pain in the Upper Jaw	Headaches
Headaches	Facial Herpes
Welts on Mouth and Lips	

Dichloroacetylene was one contaminant in the MESA atmosphere which accounts for all of the rather unusual symptoms exhibited by the crew. No information is available about the related compound, monochloroacetylene, which was also found in the MESA atmosphere. Possibly, it may induce similar effects.

The presence of dichloroacetylene in the MESA atmosphere is, of course, attributable to the partial decomposition of its precursor, trichloroethylene, by the sodium superoxide unit. Monochloroacetylene was similarly formed from vinylidene chloride, which was also present in the MESA atmosphere.

The reactions leading to the presence of dichloroacetylene in a submarine atmosphere are more involved. Methyl chloroform is a common contaminant in all our nuclear submarine atmospheres because this solvent is used in an adhesive for cementing thermal insulation to pipes and bulkheads. Normally, this contaminant is degraded to carbon dioxide and hydrochloric acid in a properly operating Hopcalite burner. A lithium carbonate filter is placed downstream from the burner to adsorb the hydrochloric acid and prevent corrosion damage. On one occasion the hopcalite unit was operated at less than optimum temperature. Under these conditions methylchloroform is only partially decomposed. Two of the partial decomposition products are vinylidene chloride and trichloroethylene. The latter compound, of course, is converted in good yield to dichloroacetylene by the lithium carbonate bed.

Many contaminant control systems for closed environmental atmospheres feature catalyst units followed by alkaline acid-adsorbing units. In view of the fact that most such atmospheres seem to get contaminated with chlorinated hydrocarbons, a dangerous situation is possible in the event the catalyst temperature falls to some unlucky level. Some idea of the danger that dichloroacetylene can present in a closed atmosphere is conveyed by the fact that British patients who barely survived dichloroacetylene exposures exhibited only slightly more severe symptoms than those experienced by the MESA crew.

The MESA experiments presented the first serious case of organic trace contamination in a confined environmental atmosphere, serious enough, in fact, to incapacitate a crew, and surprisingly, the causative agent was not a gas-off product from any cabin material, but a contaminant actually generated by the contaminant control system.

DISCUSSION

MR. MOBERG (Aerojet-General Corporation): Was the sodium hydroxide monitored in the cabin as an aerosol or dust? Did you notice any corrosion?

MR. SAUNDERS: Sodium hydroxide solidly ties to sodium superoxide in a confined depth, maintained I suppose in glass fiber filters. I don't think any of it got out into the air as particulate matter.

MR. MOBERG: You did mention quite a bit of moisture and it is possible to aerosolize the material. This could also cause probable extensive itchiness or irritation.

MR. SAUNDERS: I'm sure that was not the case.

DR. ROTH (Lovelace Foundation): Could you tell me where the trichlorethylene came from in this system?

MR. SAUNDERS: Yes, somebody had brought a bottle of it into the chamber and used it for cleanup purposes some time prior to the beginning of the manned run.

MR. BOMMARITO (Boeing Company): Were the symptoms common to all the members of the crew?

MR. SAUNDERS: Most of them were, but some of them were not. The cold sores, I believe, were experienced by four out of five of the crew members. I think the rest of the symptoms were generally common. There may have been exceptions here and there.

MR. BOMMARITO: Were the cold sores you describe identified as herpes simplex?

MR. SAUNDERS: No, they were not identified as such. They were determined, I believe, not to have been the result of a viral infection but due to chemical irritation. They were referred to as herpetiform, in other words, having a herpes like appearance.

MR. WILSON (Boeing Company): Would you have any idea what the threshold limit for dichloroacetylene might be or any data at all on actual concentrations found?

MR. SAUNDERS: The Navy is now concerned with very low concentrations. In the submarine atmosphere it was detected at a concentration less than one part per million. I don't know what the concentration was in the Mesa Chamber. Capt. Siegel of the Navy Toxicology Unit is studying the toxicity of this material right now. His work has not been completed. So far the toxicity has been determined to be as high as we had expected it would be.

FROM THE FLOOR: Was any animal experimentation done under these conditions? Do you know anything about the pathology or liver function?

MR. SAUNDERS: That work is now being done by Capt. Siegel and I presume he will report upon it when completed. I recently learned in Europe some workers were investigating the effects of high pressure helium-oxygen atmospheres and they have used sheep in the chamber. Something went wrong with one of the compressors and the gaskets split and oil leaked into part of their system. So they shut down the system, brought the chamber back to one atmosphere, removed the test animals and, believe it or not, they washed out this oil with trichlorethylene. They then brought the chamber back up to pressure with the animals inside. Part of their carbon dioxide control system was soda lime, which is pretty standard, and almost immediately thereafter they noticed that their sheep became ill. They stopped the test within a day or so thereafter, so I don't know what further results they found.

DR. FAIRCHILD (U. S. Public Health Service): What do the British attribute their fatality to? Was it on a pulmonary, cardiovascular, nervous, or what basis?

MR. SAUNDERS: I don't know that I can give a fair answer to that question. They did perform autopsies, of course, and the pathological results are recorded in the papers, but I don't recall exactly what they were.

FROM THE FLOOR: Any mention of pulmonary edema?

MR. SAUNDERS: I don't believe there was. I don't recall that they mentioned much liver damage either, but Capt. Siegel has noticed liver damage in test rats and the people I mentioned in Europe found that in sheep the first symptom was anemia.

MR. DEUSS (Douglas Aircraft Company): I'd like to point out another hazard in connection with the use of trichlorethylene. It was noticed at Douglas, where trichlorethylene was used as a cleaning solvent on a Saturn vehicle, that in combination with silica gel, a severe decomposition takes place with the evolution of phosphine and HCL. This was noted because it caused severe corrosion of aluminum welds.

DR. THOMAS: Let me take just 2 minutes here to reflect my thoughts on his first session. Dr. Vorwald mentioned the importance of extending the duration of these exposures to what we really can call chronic exposure. In instances of highly toxic or cumulative toxic agents, I think we ought to follow up some animals for their lifetime. The only problem is, as you know, that we have only four domes at the present. We hope the Congress passes the military construction program to give us four more and then we will be able to run not only acute, or short-term continuous exposures, but also start concentrating on those materials which we actually find are real problems and start developing long-term space cabin tolerance limits. About 5 years ago I remember saying in a paper that the biggest potential toxic problem we would have is the life support system. Obviously, life support systems are designed with very good safety considerations and here is no problem as long as parts function properly; but when malfunctions occur, we can get into problems real quickly.

SESSION II

COMPARATIVE TOXICOLOGY AND PATHOLOGY OF OXYGEN

Co-Chairmen

Dr. Frederick Coulston
Albany Medical College
Institute of Experimental Pathology
& Toxicology
Albany, New York

Dr. Paul Gross
Industrial Hygiene Foundation of
America, Inc.
Mellon Institute
Pittsburgh, Pennsylvania

SESSION II

Opening Remarks

DR. GROSS: I have a few things to say that may be of help to you in the evaluation of the pulmonary pathology. When irritants are inhaled, whether or not a pulmonary reaction occurs depends upon the efficiency with which the pulmonary clearance mechanism removes the inhaled irritants. Unfortunately, the pulmonary clearance mechanism is not always 100% effective and it is usually just 1 to 2% inefficiency which accounts for the establishment of pulmonary lesions. As you know, the pulmonary clearance mechanism has two components, the mucociliary escalator mechanism and the alveolar film of fluid which moves from the peripheral alveoli to the escalator mechanism. It is the latter one on which I would like to expound a little bit.

The primary lobule of the lung begins with the respiratory bronchiole. The ratio of surface areas of the alveolar membrane compared with the respiratory bronchiole in humans is as much as 500 to 1. This ratio is of importance because all the material that accumulates in the lesions has to come to the escalator mechanism through the respiratory bronchiole, similar to the drainage of a large funnel through a small opening. Naturally this is the location which will get the highest dosage of irritant, in terms of concentration and time. Another aspect which I would like to stress is the nature of the basic structure of the lung. The basic structure of the lung is, of course, the alveolar wall, which consists of a tight network of capillaries sandwiched between two very thin membranes. When an irritant, an aggressive irritant, hits the alveolar wall, it penetrates the alveolar membrane and the capillary wall is injured. The capillary responds with leakage of the wall, pouring out a fluid which is recognized as pulmonary edema, and if the animal lives long enough, there is an exudation, a pouring out of cells, precipitation of fibrin, and there is what we call acute pneumonia or chemical pneumonia. That is, then, the response of the mesodermal component of the alveolar wall. The other component, the alveolar membrane, is of entodermal origin and responds differently. With a less aggressive irritant, only the alveolar membrane responds with proliferation of cells and elaboration of a precollagenous stroma.

I'm going back now to the pulmonary clearance mechanism and give you a little illustration of how the alveolar clearance component works. If a rat is injected by tracheal cannulation with a suspension of very finely divided quartz dust (particle size less than 0.5 micron), the ash pattern shows a fairly uniform distribution of the quartz dust throughout the alveoli at zero hour. Yet within 96 hours the quartz dust is removed from the distal alveoli and is concentrated around the alveolar ducts and the respiratory bronchiole. This, then, represents the narrow end of the funnel. You'll find later on, and I'm sure the demonstrations of the subsequent speakers will point out, that the primary lesion is situated in the proximal portion of the primary lobe; namely, the respiratory bronchiole and the alveolar duct. The astonishing feature is the rapidity with which material is removed from the peripheral alveoli and lands in the respiratory bronchiole.

Now, coming back to the response of the two components of the alveolar wall to inhaled irritants, cadmium fume inhalation in a man results in tremendous edema caused by the injury to the capillary walls which cause the epithelial lining of the surface to be lifted off by the force of edema fluid. Many of the irritants damage both the capillary and the alveolar membrane. As a result there is a

combined reaction. First, exudation, which is later followed by proliferation. If a rat is injected intratracheally with a very small dose of liquid kerosene, 24 hours later the alveoli are filled with pus cells which represent the acute capillary reaction. In addition, we have proliferation of alveolar cells and find that the alveolar cells have elaborated a precollagenous stroma supporting these cells which is part and parcel of the reaction of the alveolar membrane. Three days later, the exudative phenomena disappear and only the proliferative phenomenon remains, a rather remarkable proliferation of precollagenous tissue filling the air spaces. The acme of this reaction is at 10 days postexposure.

This was merely to orient you in the subsequent demonstration of pathology to recognize that a proliferative phenomenon represents the reaction of the alveolar membrane, whereas an exudative phenomenon represents reaction of the capillary.

QUESTION FROM THE FLOOR: Does the clearance mechanism which you have illustrated with particulate matter hold true for soluble material or gaseous agents?

DR. GROSS: Animals exposed to phosgene show the same distribution of lesions, the same type of lesions. Dr. Stokinger's animals exposed to ozone, which I had the privilege of studying, show exactly the same distribution. I assure you, I cannot tell the difference between the phosgene effect and the ozone effect. They are identical insofar as appearance and localization are concerned.

DR. COULSTON: As an introduction to what we are about to hear and discuss, it is well to speculate a little bit about what modern toxicology is. Modern toxicology is a multidisciplinary approach which combines pharmacology, biochemistry, chemistry in general, and, above all, pathology. This is very important to emphasize to you because, classically, physiologists, pharmacologists, and biochemists have not been concerned with the actual pathologic state and condition that can be produced in various ways by chemical and physical agents.

The modern concept of toxicology is much more than a study of poisons. We are now more concerned with the alterations of structure, function, and response of the living organisms to chemical and physical agents. We have evolved beyond the point of simply counting the dead animals in a cage. We have evolved to the point where we are getting very sophisticated because we have tools with which to become sophisticated, the new biophysical biochemical techniques that are available to us. The pathologist has become very interested in ultrastructure, and the modern toxicologist, as you will hear today, has become very concerned with the relationship between biochemical pharmacological changes which can be measured, usually in vitro, and those changes which can be seen on an ultrastructural histochemical level by the use of such things as the electron microscope. This is a rather new development and it is going forward as fast as we all can get funds together to get electron microscopes. The time will come when for every light microscope that you have in a laboratory, you will need at least one electron microscope and maybe more. We're concerned with the intact and anesthetized animal. The modern toxicologist certainly uses the principles of classic physiology, pharmacology, and biochemistry, but above all he wants to know what's going on in the animal while it is under exposure. He wants the animal to be treated just like you are treated when you are a patient in a hospital - or better.

The point at issue is this. We need to look at the animal not only from the standpoint of physical appearance, but from what is going on inside the cell and the cells as they relate to tissues and organs. We need to know above all what one substance can do to a system, be it enzymes or reticuloendothelial system.

You've heard a lot about the recent work on drug metabolizing enzymes. These enzymes can be induced by chemicals so that metabolism of a particular chemical can be accelerated or slowed down. We need to know more about oxidation, reduction, and hydrolysis of various chemicals.

Above all, the criterion certainly has to be man, and everything we do in animals, in some fashion or other, must be capable of predicting what will happen in man. The question of which animal will predict what goes on in man, of course, no one knows. We have certain instances where the dog is good and certain instances where the rhesus monkey is better. We have certain instances where both tell you what happens in man.

With that I think we should say one further thing; as long as we're not sure how to predict from animal experience what will happen in man, human experience must take precedence over animal data. If a man is in a chamber for 14 days and nothing happens to him by all the sophisticated tests that we can undertake, then I think we must not be very concerned if some obscure rat strain reacted adversely to a particular atmosphere in the same situation. This is true whether we talk of cancer or whether we talk of space. Certainly if you produce a carcinoma in a mouse of a special strain, this has no bearing on what happens to men. We know that man has experienced such a substance as arsenic for thousands of years, literally, and has not developed any carcinoma that we know of. Should we then listen to the mouse that has the carcinoma? We feel that sooner or later we must come to the kind of experience that Mr. Saunders described, and human experience is the ultimate criterion of safety.

OXYGEN TOXICITY AT NEAR-AMBIENT PRESSURES

James D. MacEwen, Ph. D.
Charles C. Haun

Aerojet-General Corporation
Wright-Patterson Air Force Base, Ohio

Albino rats of the Wistar strain exhibited approximately 15-20% mortality between the fourth and sixth days of exposure in the first series of experiments conducted at reduced pressure in the Thomas Domes (ref 1). This mortality was uniform in all domes regardless of whether a contaminant was present or not. The ambient air control rats maintained in the animal room did not exhibit a similar mortality pattern. It was postulated that the observed albino rat mortality, not seen in other species, was caused by the reduced pressure and pure oxygen environment.

To determine whether the observed mortality response was a strain-specific effect, groups of Wistar and Sprague-Dawley SPF strain rats were introduced into another chamber under the same environmental conditions, i. e., 100% oxygen at 5 psia pressure. Essentially the same mortality pattern was demonstrated in the Wistar strain rats as mentioned above. The Sprague-Dawley rats, however, showed no sign of any ill effects from the exposure. Since it had been decided that this was essentially a strain-specific defect, two experiments were conducted to determine if the effect was the result of increased partial pressure of oxygen or decreased total pressure. The first experiment was carried out at near atmospheric pressure in the presence of 100% oxygen. The Sprague-Dawley SPF strain rats and both young and old Wistar strain rats were used; a previous experiment had shown that older Wistar strain albino rats were not as susceptible to a 5 psia - 100% oxygen environment as the younger animals of the same strain. The second experiment was conducted at near atmospheric pressure with an enrichment of oxygen to 260 mm Hg partial pressure. Both experiments were actually conducted at 700 mm Hg total pressure in order to effect complete chamber sealing. The results of these experiments are shown in table I.

Converse to the results of 100% oxygen experiments at reduced pressure, the older Wistar rats exhibited greater susceptibility to the toxic effects of oxygen when compared with younger rats of the same strain. More important, however, was the overall reduction in expected mortality of both strains of rats continuously exposed for a period of 10 days to a 100% oxygen environment at near-ambient pressure. This is in conflict with previous studies reported by Weir (ref 2) and others (ref 3, 4). The principal difference between this experiment and that reported by Weir was that the experimental chambers were operated under dynamic flow conditions with all exhaust oxygen being vented to the atmosphere. Most reported experiments on oxygen toxicity at ambient pressure were conducted in recirculating systems with the removal of water vapor and carbon dioxide and the subsequent replacement of the oxygen consumed for animal metabolism. Hulpieu (ref 5), however, reported results similar to those found in this laboratory, specifically lower mortality in experiments conducted in a dynamic system, exposing small groups of rats for periods of 10 days.

TABLE I
 OXYGEN TOXICITY AT NEAR AMBIENT PRESSURE
 MORTALITY
 (NO. DEATHS/NO. EXPOSED)

OXYGEN CONCENTRATION (%)	100	33-1/3	20
PRESSURE (mm Hg)	700	700	740
CONTINUOUS EXPOSURE			
SPRAGUE-DAWLEY (125-150 gm)	0/50	0/50	0/40
WISTAR (125-150 gm)	5/50	0/50	0/40
WISTAR (300-350 gm)	21/25	0/25	0/25
INTERMITTENT EXPOSURE			
SPRAGUE-DAWLEY (125-150 gm)	0/50		0/40
WISTAR (125-150 gm)	0/50		0/40

In view of the differences between the observed toxic response to oxygen at near ambient pressure in dynamic flow and recirculating exposure chamber systems, it was decided that this experiment should be repeated using several additional species for comparison with published data. The results of the repeat experiment are shown in table II in which they are compared with data obtained and published by The Army Chemical Center (ref 2). While the total mortality for species other than the rat is essentially comparable, the LT_{50} value for an exposure somewhat longer in time is considerably extended. Again this may be the result of the use of the dynamic flow system in our experiments. Values for rats and monkeys are shown in table II since only one of the 110 rats exposed died and that on the 14th day of the experiment. One of the four exposed monkeys also died on the 14th day. In the study repeated by The Army Chemical Center, the LT_{50} value for monkeys was not calculated although one of the two exposed animals died at 150 hours and the second after 216 hours.

If the mortality differences observed in recycling versus dynamic flow systems are due to an accumulation of trace contaminants in the recirculating system, the studies are relevant to manned space flight, since the oxygen supply of a space cabin is recycled through an air-conditioning and purification system. To elucidate whether these observed differences in mortality, a series of experiments was conducted using 100% oxygen environment at total pressures ranging from 760 mm Hg pressure to 600 mm Hg pressure. The comparison of species mortality at different pressures is shown in table III. From the appearance of those animals which survived 16 days exposure to 100% oxygen at pressures above 695 mm Hg, it may be assumed that longer exposure periods would have resulted in total mortality. The mortality response of monkeys is not clear-cut but might be expected to parallel dog response if larger numbers of animals had been used.

TABLE II
OXYGEN TOXICITY
COMPARATIVE TIME MORTALITY VALUES

	<u>THRU LABORATORY</u>	<u>ARMY CHEMICAL CENTER</u>
CHAMBER PRESSURE	695 mm Hg	765 mm Hg
CHAMBER OPERATION SYSTEM	DYNAMIC FLOW	RECIRCULATION
LENGTH OF EXPOSURE	360 HOURS	240 HOURS
<hr/>		
MICE:		
RANGE OF TIMES TO DEATH	137-350	72-201
LT ₅₀	306	126
NO. DEATHS/NO. EXPOSED	34/40	25/25
% MORTALITY	85%	100%
DOGS:		
RANGE OF TIMES TO DEATH	78-264	62-100
LT ₅₀	119	79
NO. DEATHS/NO. EXPOSED	8/8	5/5
% MORTALITY	100%	100%
GUINEA PIGS:		
RANGE OF TIMES TO DEATH	109-230	62-100
LT ₅₀	118	79
NO. DEATHS/NO. EXPOSED	8/8	10/10
% MORTALITY	100%	100%

In one final experiment conducted in 100% oxygen environment at 760 mm Hg total pressure for a 14-day period, albino rats (including a third strain, i. e. Sprague-Dawley (supplied by Harlan Industries, Inc.) were again tested and the total mortality observed for the combined group is also shown in table III. While there was no significant difference in total mortality between the Wistar, Sprague-Dawley from Harlan Industries, Inc., and Sprague-Dawley SPF strains, there was an apparent difference in the mortality pattern with respect to time of death. The majority of the Wistar and Sprague-Dawley (Harlan) rats died within the first 5 day of the exposure, while the bulk of the deaths in the Sprague-Dawley SPF rats occurred between the 9th and 14th day. This difference in mortality pattern, however, was less than that seen in the Sprague-Dawley SPF rats in successive experiments conducted at 760 and 720 mm Hg pressure.

The mortality observed at various absolute pressures is illustrated graphically in figure 1. While dogs and mice exhibit essentially a similar pattern of oxygen toxicity response, the albino rat is shown to be much less susceptible to oxygen toxicity than any of the other three species tested, as has been reported earlier by Smith et al (ref 6) and Boycott and Oakley (ref 7).

TABLE III
 COMPARATIVE OXYGEN TOXICITY
 760-600 mm Hg PRESSURE
 MORTALITY
 (NO. DEATHS/NO. EXPOSED)

EXPERIMENT NO.	136	144	138	132	139	142
DAYS EXPOSED	16	14	16	16	16	16
CHAMBER PRESSURE	760	760	720	695	650	600
SPECIES						
MICE	40/40		39/40	34/40	21/40	1/40
RATS	55/100	39/150	41/92	1/50	1/80	0/80
DOGS	4/4		4/4	8/8	2/8	1/8
MONKEYS		3/4	0/4	1/4	2/4	0/4

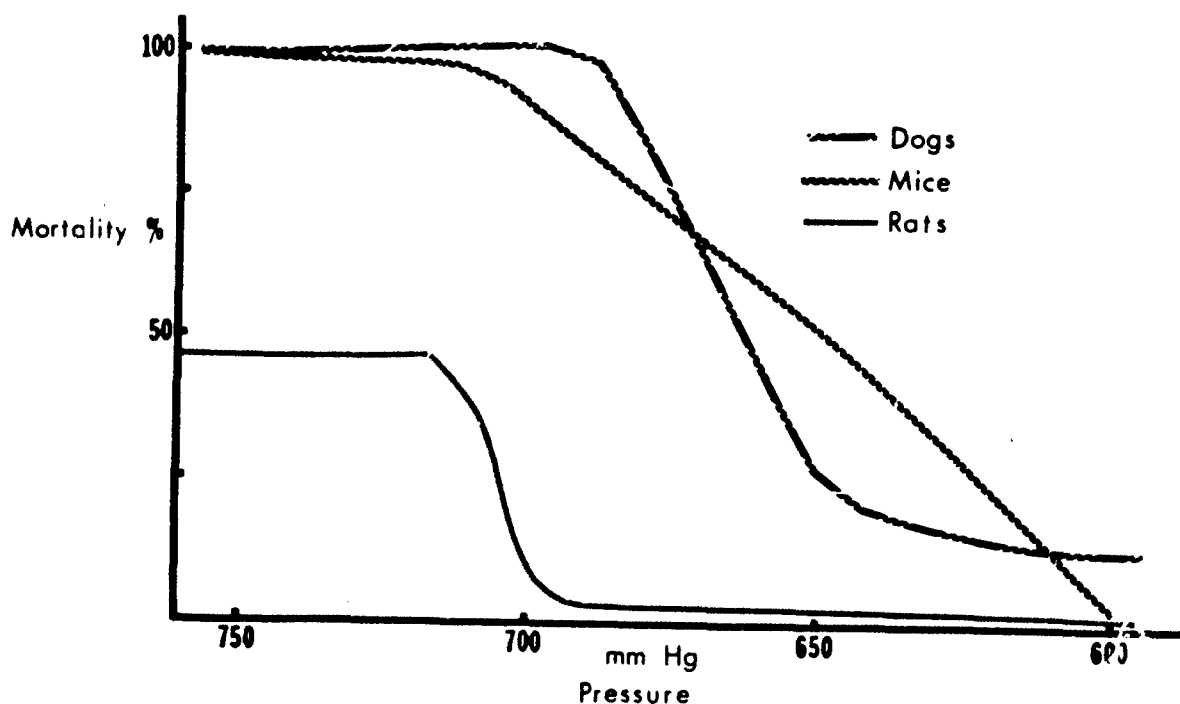

Figure 1. OXYGEN TOXICITY MORTALITY AT VARYING ABSOLUTE NEAR-AMBIENT PRESSURES IN EXPERIMENTAL ANIMALS

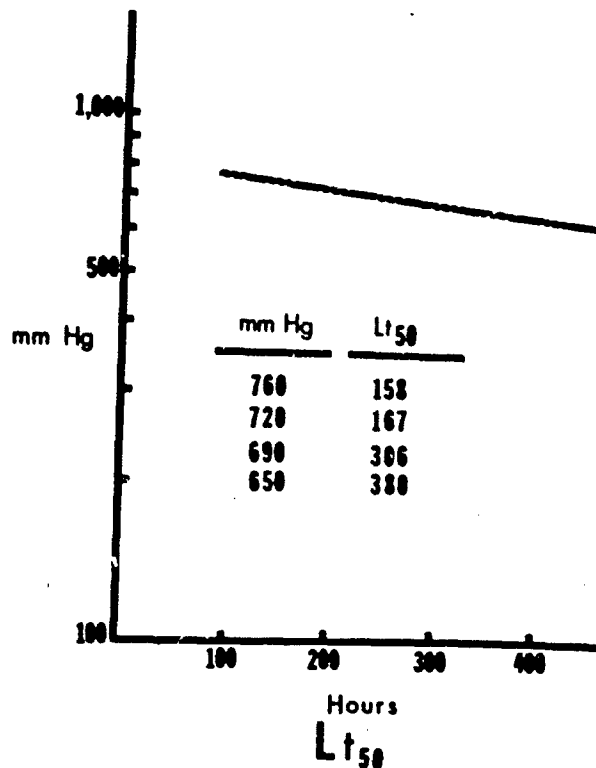

Figure 2. OXYGEN TOXICITY MORTALITY RESPONSE OF ALBINO MICE AT VARYING ABSOLUTE PRESSURES

The correlation between LT_{50} values and actual chamber pressure is shown in figure 2 for albino mice. This was the only species that exhibited a mortality response throughout most of the pressure range investigated. From this curve the mortality response can be predicted for the lowest pressure tested. The time to first death was predicted at 600 mm Hg pressure and was found accurate. Also shown is the orderly progression of time to death with increase in pressure up to 760 mm Hg, which was the highest absolute pressure tested.

While adequate numbers of dogs and monkeys were not used for such a purpose, a consistent pattern of sex difference was observed in rat mortality. A comparison of several experiments is shown in table IV. Therein is illustrated the higher mortality rate observed in male rats. This increase over the female rats, however, may again be a demonstration of the higher mortality observed in larger animals, which was described earlier in comparison with young versus old Wistar rats shown in table I.

In summary, these experiments have shown a decreasing oxygen toxicity response with decreasing total pressure. They have demonstrated a difference in response between young and older animals and have possibly demonstrated a sex difference in toxic response between male and female rats. The mortality rate of Wistar strain rats exposed to a 5 psia - 100% oxygen environment can be definitely ascribed to a strain-specific pressure sensitivity. In addition, a definite difference in toxic response has been demonstrated between experiments conducted in dynamic flow and recirculating exposure chamber systems. It would appear that some metabolic waste materials or their oxidation products may be accumulated in a recirculating system which are capable of enhancing oxygen toxicity.

TABLE IV
 OXYGEN TOXICITY
 NEAR-AMBIENT PRESSURE
 MORTALITY - ALBINO RAT
 SEX DIFFERENCE

EXPERIMENT NO.	136	144	138	
PRESSURE (mm Hg)	760	760	720	PERCENT OF TOTAL
MORTALITY (NO. DEATHS/NO. EXPOSED)				
MALE	35/50	24/75	25/50	48%
FEMALE	20/50	15/75	13/50	27%

ACKNOWLEDGMENT

This work was supported in part by the Aerospace Medical Research Laboratories under Contract AF 33(657)-11305 and the National Aeronautics and Space Administration under PR T-31248-G.

REFERENCES

1. McNerney, J. M., and J. D. MacEwen, Comparative Toxicity Studies at Reduced and Ambient Pressures, I. Acute Response; Amer. Ind. Hyg. Assoc. J. 26: 568 (1965).
2. Weir, F. W., D. W. Bath, P. Yevich, and F. W. Oberst, Study of Effects of Continuous Inhalation of High Concentrations of Oxygen at Ambient Pressure and Temperature; Aerospace Med. 36: 117 (1965).
3. Bean, J. W., Hypophyseal and Adrenocortical Factors in Pulmonary Damage Induced by Oxygen at Atmospheric Pressure; Am. J. of Physiol. 172: 168 (1953).
4. Comroe, J. H., and R. D. Drips, Oxygen Toxicity; J. A. M. A. 128: 710 (1945).
5. Hulpieu, H. R., and V. V. Cole, The Effects of Humidity and Temperature on Oxygen Toxicity; J. Lab. and Clin. Med. 29: 1134 (1944).
6. Smith, F. J., J. W. Heim, R. M. Thompson, and C. K. Drinker, Body Changes and Development of Pulmonary Resistance in Rats Living Under Compressed Air Conditions; J. Exper. Med. 56: 63 (1932).
7. Boycott, A. E., and C. L. Oakley, Oxygen Poisoning in Rats; J. Path. & Bact. 35: 468 (1932).

DISCUSSION

DR. COULSTON: This is a beautiful example of comparative toxicology and adds a great deal to our knowledge of which species one should play with.

DR. SCHAEFER (U. S. Naval Medical Research Laboratory): What kind of screening procedures have you used? Did you test the animals for leucocyte counts before you put them in the chamber? The reason I ask this is because we have tremendous seasonal differences in individual batches of the same strain of animals. You might have a mortality of 60% in spring and 20% in fall. You might also have certain breeding difficulties in the stocks so you will have a number of variables which cannot be attributed to the changes in your chamber design but simply to the selection of animals.

DR. MAC EWEN: Yes, we did do some screening. We did not do blood testing on the rats prior to exposure. The rats were brought in 2 or 3 weeks in advance of exposure. Their growth rates were followed. The ones that did not do well were cast aside and only the normal, healthy, weight-gaining rats were used. The same was true of mice. In the case of dogs and monkeys, they were held 4 to 6 months in advance. The complete hematological and chemistry picture was evaluated periodically during that isolation or pretest period, and at least four consecutive normal baselines were required before an animal was used in the experiment to eliminate any dogs with parasitic problems or liver dysfunction, and to eliminate the tubercular monkey.

PATHOLOGICAL EVALUATION OF OXYGEN TOXICITY AT NEAR-AMBIENT PRESSURES

Farrel R. Robinson, Major, VC, USAF
David T. Harper, Jr., Captain, MC, USAF

Aerospace Medical Research Laboratories
Wright-Patterson Air Force Base, Ohio

INTRODUCTION

The evaluation of oxygen toxicity at near-ambient pressures on a morphological basis centers around the response of the lung, the primary target organ. Acute pulmonary lesions have been described for most laboratory species, including monkeys (ref 1, 2, 4, 6, 10, 11, 13). These acute lesions, which have been generally accepted as classical for oxygen toxicity, include extensive pulmonary edema with congestion and some hemorrhage. Copious amounts of serous pleural fluid often coexist with these acute pulmonary lesions. Subacute proliferative pulmonary lesions developing in the lungs of monkeys in response to high concentrations of oxygen have also been reported (ref 10). This type of lesion is more common in monkeys than the acute lesion. Rat lungs may develop somewhat similar lesions at the lower dose levels (ref 3). This report discusses the effect of species, age, strain, and individual susceptibility on the type and severity of lesion induced by continuous exposure to high concentrations of oxygen at pressures of 600 to 760 mm Hg for periods up to 16 days in the Thomas Domes (ref 12).

SPECIES

Rats, mice, and dogs have shown acute pulmonary lesions which have been described by others (ref 1, 2, 4, 11, 13). These lesions were also seen in a limited number of monkeys (*Macaca mulatta*) exposed to high concentrations of oxygen at 760 mm Hg pressure (ref 10). Lungs in all species with acute lesions showed varying degrees of congestion and hemorrhage in all lobes; severe edema was most evident microscopically. The lungs were firm and red to bluish red in all cases, and collapsed if the exudation of pleural fluid was extensive. Excessive amounts of pleural fluid were usually seen in those rats, mice, and dogs that died in 3 to 4 days in a 95-98% oxygen atmosphere at a pressure of 760 mm Hg. As much as 10 ml of pleural fluid was withdrawn from the pleural cavities of 150-gram rats.

Interstitial inflammation was evident in animals surviving more than 3 or 4 days. In some of our rats' lungs, infectious foci could be detected by gross examination by the 8th to 10th day of exposure. Early proliferative changes were also seen in our rats exposed continuously for 10-14 days. Thickening of the alveolar walls and edema within the lung parenchyma have also been reported in rats exposed at 600 mm Hg for 28 days (ref 3).

All monkeys exposed to 96-98% oxygen at pressures of 600, 650, 690, 725, and 760 mm Hg that survived for more than 4 days have shown subacute proliferative lesions in the lungs (ref 10). The earliest stage of this subacute response was recognized microscopically on the 5th or 6th day of exposure at 760 mm Hg as mild

hypertrophy of the alveolar lining cells of septae containing inflammatory cells. These inflammatory cells were primarily immature lymphocytes with small numbers of mesenchymal cells also contributing to the thickness of the septae. Resolving exudate in the alveoli consisted of fibrin with entrapped neutrophils, mononuclear phagocytic cells, and occasional desquamated alveolar cells.

This type of cellular reaction progressed to the maximum in 14 to 16 days in similarly exposed monkeys. On gross examination, the lungs of these monkeys were nearly bloodless and tan or yellowish-gray with nearly dry surfaces. They were quite firm and sank in the formalin fixative. Slices of these lungs were comparable in texture and appearance to slices of liver from an exsanguinated monkey. The weights of six of these lungs ranged from 2.23 to 3.39% of the respective body weights. Control monkey lungs seldom exceeded 1% of body weight.

Microscopic examination of these heavy lungs revealed septae that were greatly thickened by collagenous and reticular fibers, moderate numbers of small lymphocytes, and fibroblasts (figure 1). The epithelium lining the alveoli was hyperplastic and desquamated hypertrophic lining cells were numerous in the alveoli (figure 2). This lesion is quite similar to the acute diffuse interstitial fibrosis of human lungs as reported by Hamman and Rich (ref 7).

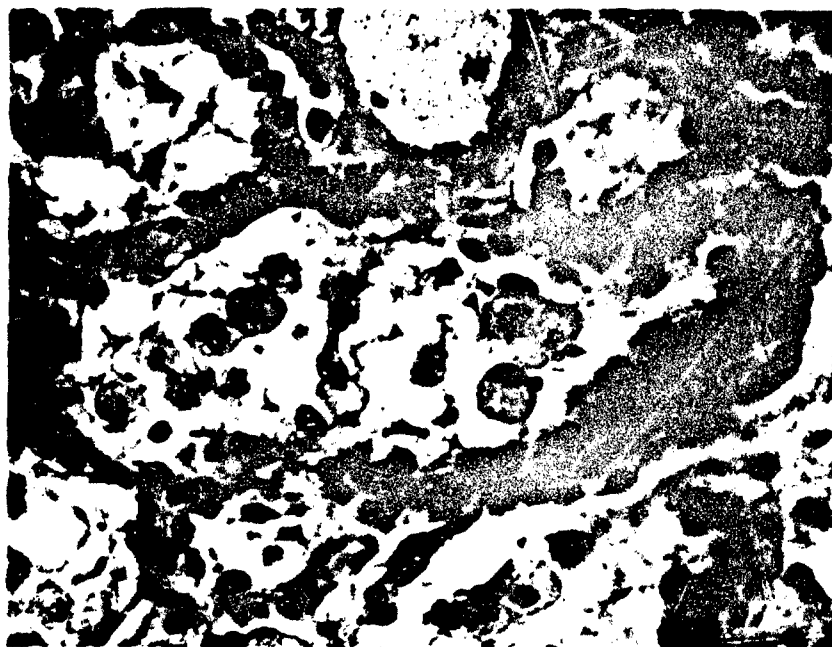

Figure 1. THICKENED INTERSTITIUM WITH INFLAMMATORY CELLS AND COLLAGENOUS TISSUE, ALVEOLAR EXUDATE, AND HYPERTROPHIC LINING CELLS IN THE LUNG OF A MONKEY SURVIVING A 16-DAY EXPOSURE TO OXYGEN AT 725 mm Hg (H & E STAIN - x 400)

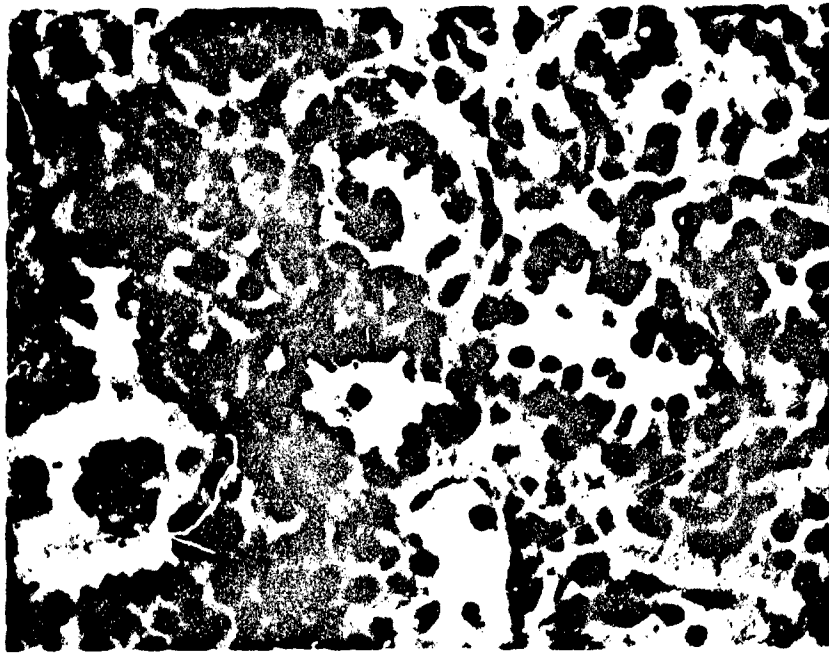

Figure 2. HYPERTROPHY OF ALVEOLAR LINING CELLS IN THE LUNG OF A MONKEY SURVIVING EXPOSURE TO OXYGEN AT 725 mm Hg FOR 16 DAYS (H & E STAIN - x 400)

Therefore, in our 2-week experiments at near-ambient pressure, acute exudative pulmonary lesions were seen primarily in dogs, rats, and mice dying in the first week and subacute proliferative pulmonary lesions were seen consistently in monkeys and sometimes in rats during or at the end of the second week of exposure.

AGE

Young rats and monkeys have shown a greater resistance to oxygen toxicity at near-ambient levels than older animals. In our experiments Wistar and Sprague-Dawley rats weighing from 200 to 400 grams have had higher mortality rates when exposed at 760 mm Hg than rats weighing from 100 to 150 grams. The older rats died earlier (Lt 50 - 60 to 70 hours) and showed the typical acute lesions more uniformly. This age dependence has been confirmed by others (ref 3). Our series of experiments with monkeys indicates a similar age dependence (ref 10).

STRAIN

A significant difference in mortality between two strains of rats exposed to high concentrations of oxygen at 258, 700, and 760 mm Hg has been demonstrated (ref 9). Wistar rats when exposed at these pressures had mortality rates of 25, 10, and 26% compared to specific pathogen free (SPF) Carworth Sprague-Dawley rats with mortality rates of 0, 0, and 22%, respectively. In addition, another group of

conventionally raised Harlan Sprague-Dawley rats from a different source was compared to the other two groups of rats in the 760 mm Hg experiment; this group had a 30% mortality.

The pattern of deaths in the 760 mm Hg experiment was particularly significant with regard to the type of lesion produced. Most of the SPF Carworth Sprague-Dawley rats died late in the 2-week experiment with poorly developed subacute fibrotic lesions, while mortality in the conventionally raised Harlan Sprague-Dawley rats occurred early with typical acute lesions. Harlan Sprague-Dawley rats have been used in the Aerospace Medical Research Laboratories for the past 3 years in other oxygen toxicity experiments and have reacted in the classic manner to high levels of oxygen (ref 4, 5). The mortality curve of the Wistar rats fell between those of the two Sprague-Dawley groups; those rats dying in the first 3 or 4 days had acute lesions and those dying later had subacute lesions. This apparent lack of predictability of response of rats to oxygen was experienced by another laboratory that used Sprague-Dawley rats from two sources to study chronic oxygen effects (ref 8).

INDIVIDUAL SUSCEPTIBILITY

Variations of individual response to noxious stimuli (infectious, parasitic, chemical, or physical) were evident in the biological responses of our experimental animals to high concentrations of oxygen. As noted above, there are considerable differences between species, age, and strain which, in turn, influence the type of lesion produced. Even in groups of rats that were closely related genetically, the same age, handled identically since birth, and exposed to the same concentration of oxygen, there were significant differences between individuals that resulted in different types of pulmonary lesions. This variability was dramatically demonstrated in our rat experiments. If the individual susceptibility was high, regardless of strain or age, the rat died within the first 3 or 4 days of the experiment and demonstrated classical lesions of acute oxygen toxicity. If a rat was not so susceptible, it would live through the acute stages, accommodate, and later develop subacute lesions. Our groups of monkeys, as most other groups of monkeys, were not as homogeneous as were the rats, and individual variation in susceptibility to oxygen was quite evident. A limited number did die of acute oxygen toxicity. While most of them had clinical symptoms of acute oxygen toxicity, nearly all accommodated so that the typical subacute response in the lung could develop.

SUMMARY

The type of pulmonary lesion induced by high concentrations of oxygen at pressures of 600-760 mm Hg depends upon the species, age, strain, and individual susceptibility of the experimental animal. Monkeys are apparently more resistant to acute oxygen toxicity than rats, but do develop an extreme subacute pulmonary proliferative response. Younger animals seem to have more resistance to high concentrations of oxygen than older animals. Pronounced differences in mortality, and consequently pulmonary lesions, indicate that a conventionally raised Harlan Sprague-Dawley strain of rats is more susceptible than either a Wistar strain or a specific pathogen free (SPF) Carworth Sprague-Dawley strain. Differences in

individual susceptibility of a supposedly homogeneous group of either monkeys or rats are quite evident; some animals die with acute lesions and others accommodate and later develop subacute lesions. Therefore, the pathologic response of the lung to high concentrations of oxygen is quite variable with many biological influences contributing to the ultimate pathologic picture.

REFERENCES

1. Bean, J. W.: Effects of Oxygen at Increased Pressure. Physiol. Rev. 25: 1, 1945.
2. Bean, J. W., and Smith, C. W.: Hypophyseal and Adrenocortical Factors in Pulmonary Damage Induced by Oxygen at Atmospheric Pressure. Am. J. Physiol. 172:169, 1953.
3. Brooksby, G. A., Dennis, R. L., and Staley, R. W.: Effects of Prolonged Exposures to Increased Oxygen Pressures. In Press.
4. Felig, P.: Oxygen Toxicity: Ultrastructural and Metabolic Aspects. Aerospace Med. 36:658, 1965.
5. Felig, P.: Observations on Rats Exposed to a Space Cabin Atmosphere for Two Weeks. Aerospace Med. 36:858, 1965.
6. Friedrich, M., and Grayzel, D. M.: High Resistance of Rhesus Monkeys to 90 Plus Per Cent Oxygen. Proc. Soc. Exp. Biol. Med. 56:204, 1944.
7. Hamman, L., and Rich, A. R.: Acute Diffuse Interstitial Fibrosis of the Lungs. Bull. Johns Hopkins Hosp. 74:177, 1944.
8. Kydd, G. H., Kowalski, L., and McGowan, R.: Lack of Predictability in Rats to Exhibit Chronic Oxygen Poisoning. NADC-MA-6324, Naval Air Development Center, Johnsville, Pennsylvania, 30 December 1963.
9. Robinson, F. R., Harper, D. T., Jr., and Kaplan, H. P.: Comparison of Strains of Rats Exposed to Oxygen at Various Pressures. In Press.
10. Robinson, F. R., Harper, D. T., Jr., Thomas, A. A., and Kaplan, H. P.: Proliferative Pulmonary Lesions in Monkeys Exposed to High Concentrations of Oxygen. In Press.
1. Roth, E. M.: Space-Cabin Atmospheres. Part I - Oxygen Toxicity. NASA SP-47, National Aeronautics and Space Administration, 1964.
2. Thomas, A. A.: Low Ambient Pressure Environments and Toxicity. Arch. Environ. Health, 11:316, 1965.
3. Weir, F. W., Bath, D. W., Yevich, P., and Oberst, F. W.: Study of Effects of Continuous Inhalation of High Concentrations of Oxygen at Ambient Pressure and Temperature. Aerospace Med. 36:117, 1965.

DISCUSSION

DR. JACOBSON (Department of Health, Education and Welfare): Do you know about the origin of the two Sprague-Dawley strains? Is one derived from the other, or are they of separate origins?

MAJ. ROBINSON: They are of separate origins.

DR. JACOBSON: If they are of separate origins, then would it not be correct to infer that the differences you saw are due to the differences in specific pathogen free or nonspecific pathogen free status?

MAJ. ROBINSON: I didn't mean to infer this, although our SPF rats were SPF at the time we received them. We had no way of maintaining them in an SPF environment during exposure. Now there's variability in the strains of rats, even in the same strain procured from two different places. It was pointed out in a Navy publication just recently by Dr. Kidd, I believe, that there is an extreme amount of variability in rats.

DR. JACOBSON: Did you find that SPF rats too can degenerate to develop pneumonia?

MAJ. ROBINSON: Yes, at times. Now Capt. Harper, who will speak a little later today, will have some comments to make in this regard, particularly with supposedly spontaneously occurring pulmonary lesions.

DR. FAIRCHILD (U. S. Public Health Service): The alveolar wall thickening that occurred, how long does this last? What's the longest time you've seen this to occur after an exposure?

MAJ. ROBINSON: I can't really give you an answer because generally we killed our animals immediately following exposure. Only in the case of the four or five animals you are referring to have we kept them for a period of 30-45 days postexposure.

DR. GROSS: I might be able to answer that question. The pulmonary response which Maj. Robinson described is not unique to oxygen and it's common to quite a number of irritants which produce the same lesion. As long as this stroma is precollagenous as judged by silver impregnation techniques and consists of reticular fibers only and no collagen is formed, the lesion is reversible. As far as phosgene is concerned, within a month the lesion is gone, although some slight effects still remain.

DR. COULSTON: This is a very important point. I think we have to be careful. We say "lesions" and we say "proliferative changes" when we might not mean either. What we may mean is just inflammation. There are a lot of cellular changes that could be called proliferative and are nothing but end products of cells and inflammation. It is very important to emphasize the point of reversibility because if it is indeed reversible, it isn't a lesion in the sense a lot of people might think it is. The use of the word "proliferative" really scares some people and they

think right away of cancer. I think this paper is a beautiful paper and these are some of the best pictures of lung pathology I have seen in many a year. I would say just this in summary, nothing goes on in the lung that is peculiar to the lung only. It goes on in other tissues too. Wherever there's loose connective tissue, you'll find inflammatory processes and these processes are the same whether they go on in the skin or whether they go on in the lung. I may get an argument on this point but we are involved here with the basic problems of inflammation.

MAJ. ROBINSON: I don't know of a term other than "proliferation" that would adequately describe the two- to threefold increase of tissue that we have seen in these lungs.

DR. GROSS: This, of course, is a matter of semantics.

DR. COULSTON: Let me ask just one other question, how often do you see mitosis in these cells?

MAJ. ROBINSON: There were relatively few of them.

DR. COULSTON: This is the point. Perhaps what we see on a slide is an end product of cells coming there. It's a "still" picture at the specific time that you take it, but every one of these cells, or most of these cells that you are looking at, say 85% of them, are coming from somewhere. At the stage where you are looking at them they are there, and they will be somewhere else in a matter of hours or less. What you are looking at is a dynamic system and it's very easy to put a picture before us (and I do it too, so this is not peculiar, all pathologists do it, all histopathologists do it). But we must bear in mind that these are dynamic changes going on. These cells you are looking at evolve from, perhaps, a cell from a different stage, but they are the same cell, they are just growing and changing. And I would say 85% of the cells you show there are in that category.

**TOXICITY STUDIES ON ANIMALS EXPOSED CONTINUOUSLY
TO A 5 PSIA 100% OXYGEN ENVIRONMENT FOR PERIODS UP TO 235 DAYS**

Kenneth C. Back, Ph.D.

Aerospace Medical Research Laboratories
Wright-Patterson Air Force Base, Ohio

INTRODUCTION

This paper concerns the effects of 100% oxygen at 5 psia on animals exposed continuously for periods up to 235 days. It will contain clinical parameters only and should pave the way for the pathology reports that follow.

First, a recapitulation is in order on some work reported at last year's Conference by Mr. McNerney on 100% oxygen, 5 psia effects from 14 to 90 days' duration. The mortality for mice, rats, dogs, and monkeys is found in table I.

TABLE I

MORTALITY FROM CONTINUOUS EXPOSURE TO 5 PSIA, 100% OXYGEN

DAYS OF EXPOSURE	NO. DEAD/NO. USED			
	MICE	RATS*	DOGS	MONKEYS
14	1/100	15/100	0/10	0/10
28	0/59	1/53	0/8	0/8
60	2/49	5/44	0/6	0/6
91	3/40	1/32	0/4	0/4
Total Dead	6	22	0	0

*Wistar Rats (Altitude Sensitive)

No dogs or monkeys succumbed to this atmosphere while 6 mice and 22 rats died on various days of exposure. The mouse deaths are not different from control animals however, after further experiments the rat deaths proved to be strain dependent, and Sprague-Dawley derived, pathogen free rats were used in all subsequent experiments. No adverse effect on growth or organ weights was noted in any of the animals studied, and the only pertinent finding in serum enzyme activity was an apparent increase in the serum glutamic-pyruvate transaminase (SGPT) levels in dogs (table II).

This trend was not evident in monkeys, and neither dogs nor monkeys showed significant changes in serum glutamic-oxalacetic transaminase (SGOT) levels.

Perhaps the pathologists can tell us if these SGPT levels mean anything in terms of liver damage.

TABLE II
SGPT AND SGOT DATA FROM 14-90 DAYS'
CONTINUOUS EXPOSURE TO 5 PSIA, 100% OXYGEN

DAYS OF EXPOSURE	MEAN SGPT		MEAN SGOT	
	DOGS	MONKEYS	DOGS	MONKEYS
14	24	35	22	43
28	21	29	24	35
60	30	35	29	43
91	33	29	28	40
Control	17 ± 7.5	27 ± 6.5	24 ± 11	36 ± 10

Since these early studies through 90 days showed relatively little clinical change, our next experiment was designed to see if animals could withstand the 5 psia, 100% oxygen environment for 365 days. We surmised that a 1-year study would provide good background information for any subsequent toxicological studies we might wish to perform, and, in addition, if successful, might be the first step toward future manned flights of long duration. However, this study only proceeded for 235 days, since the Air Force placed more emphasis on two-gas systems.

EXPERIMENTAL PROTOCOL

Forty male mice, 65 male rats (Sprague-Dawley), 4 male and 4 female beagle dogs, and 2 male and 2 female Macaca mulatta monkeys were placed in dome No. 4 for the experiment. Forty mice, 50 rats, 4 dogs, and 2 monkeys were used as control animals and held under ambient conditions. All experimental animals were weighed and clinical chemistry baseline values were determined at least four times during the month before exposure. The clinical parameters studied for dogs and monkeys are listed in table III.

TABLE III
CLINICAL LABORATORY TESTS PERFORMED

Hematology

WBC, Differential Count, RBC, Hemoglobin, Microhematocrit

Clinical Chemistry (Serum)

Sodium, Potassium, Calcium, Total Protein, Albumin, A/G Ratio, SGPT, SGOT, Alkaline Phosphatase, Total Inorganic Phosphorus, Lactic Dehydrogenase

Operating parameters for dome No. 4 are listed in table IV.

TABLE IV

DOME 4 OPERATING PARAMETERS

Atmosphere Composition	100% Oxygen
CO ₂	0.1 (0.07 - 0.72) %
Total Pressure	260 mm Hg
O ₂ Partial Pressure w/Leak Rate	258 mm Hg
N ₂	0.5 - 1.4%
Flow Rate of O ₂	25 (18 - 25) cfm
Temperature	72 (71 - 76) F
Humidity	50 (44 - 74) % RH

These are the parameters that were used for all the experiments that Drs. Harper and Patrick report in subsequent papers. The atmospheric composition was, for all practical purposes, 100% oxygen. The leak rate, humidity, and CO₂ amounted to approximately 2 mm Hg pressure. The CO₂ was kept below 0.5% and most of the time was around 0.1%. The only times it ever exceeded 0.5% occurred when more than one individual entered the dome for the purpose of collecting biological data.

Mortality data on day 230 are shown in table V. After the 230th day, animals were necropsied on different schedules as needed for electron microscopic studies of lungs, kidneys, and livers. Other studies were performed to obtain cellular enzyme data. These are presented in subsequent papers by Drs. Patrick, Kistler, Schaffner, Mautner, Riesen, and Kaplan. Some of the animals were held for 30 days in the vivarium to compare pathology with those necropsied immediately after exposure.

TABLE V

MORTALITY DATA

	<u>Experimental</u>	<u>Control</u>
Mice	8/40	11/40
Rats	3/65	12/46
Dogs	0/8	0/4
Monkeys	0/4	0/2

The hematologic data from these studies are found in table VI (190 days) and table VII (230 days). There were no really significant differences in any of the parameters studied at either the 190- or 230-day interval. The data are presented as mean values with standard deviation and range. If one were to compare these data, some of the pre- and postexposure parameters might appear to be slightly significant at any given time. This is due to the fact that there were quite large fluctuations in data from individual animals since samples were taken every 2 weeks throughout the course of the experiment. These data have been compiled directly for the purpose of getting it all on one chart; however, when looking at each individual animal and following each test on that animal, it became readily apparent that the parameters cycled upward and downward as the experiment proceeded. It was quite evident then that there were no significant changes from normal ranges over the total period of time. The hematocrit and hemoglobin changes that were seen were very slight and could be accounted for by the fact that the dogs were very young when the experiment started. Those postexposure data that were obtained in animals retained for 30 days postexposure were too few to make a statistical evaluation. However, they were not appreciably different from those data taken on the 10th day when viewed on an individual basis. Therefore, we have come to the conclusion that from the clinical chemistry of these animals, their clinical appearance, and their normal growth curves, the 230-day exposures to 100% oxygen at sea level caused no changes in these parameters. If there are subtle cellular changes, they will have to be evaluated by the light and electron microscopists. These studies are described in later papers.

I might add some comment regarding the efficacy of serum clinical chemistry changes as means of indicating early cellular changes. In our experience, we have had animals die within a few hours after obtaining a blood sample and have seen no changes of significance. We continue to do these tests on blood because they do give us some indication of the health status of the animal and, in those instances where certain serum enzymes are decreased, they may be of predictive value and indicate cellular damage. However, in those cases where an increase in serum enzymes would indicate pathology at the cellular level, we usually do not get this deflection until marked microscopic changes have occurred. For these reasons, we are seriously considering the possibility of doing punch biopsy work, especially for kidney and liver function, in future experiments. We hope to be able to run a battery of both oxidative enzymes and drug metabolizing enzymes at the cellular level.

TABLE VI
190-DAY DATA AT 5 PSIA, 100% OXYGEN

TEST	GP	DOGS			MONKEYS				
		PRE-EXPOSURE			PRE-EXPOSURE				
		Mean	S.D. -Range	S.D. -Range	Mean	S.D. -Range	S.D. -Range		
HCT %	C	43.0	2.4 (39-48)	46.0	2.1 (44-49)	38.0	2.4 (35-45)	42.0	2.0 (34-44)
HGB gm%	E	14.0	0.9 (12.3-15.7)	45.0	2.2 (42-49)	11.2	0.6 (10.3-12.7)	36.0	2.5 (34-40)
RBC x 10 ⁶	C	4.3	0.4 (3.7-5.6)	6.3	0.3 (5.7-6.6)	4.0	0.3 (3.4-4.5)	4.9	0.1 (4.8-5.0)
WBC x 10 ³	E	11.8	2.1 (8.1-17.6)	6.0	0.3 (5.5-6.2)	13.5	2.3 (9.0-17.1)	4.6	0.4 (3.9-5.0)
SODIUM meq/liter	C	145.0	2.4 (140-151)	12.2	2.0 (11.4-13.0)	149.0	3.9 (144-158)	13.1	1.2 (11.9-14)
POTASSIUM meq/liter	E	4.9	0.2 (4.4-5.4)	12.3	2.2 (9.4-16.2)	152		16.1	0.6 (15.3-16)
CALCIUM meq/liter	C	5.6	0.2 (5.2-6.0)	149.0	2.0 (147-152)	5.0	0.5 (4.1-6.2)	5.0	2.0 (150-154)
TOT. PROTEIN gm%	E	5.4	0.3 (4.7-6.0)	146.0	2.2 (143-152)	5.1	0.3 (4.7-5.6)	4.9	0.7 (151-153)
ALBUMIN gm%	C	3.4	0.2 (2.4-4.0)	5.0	0.3 (4.9-5.0)	5.8	0.4 (5.1-6.3)	5.8	0.6 (4.5-5.6)
SGPT SF units	E	23.0	8.1 (7-35)	5.1	0.3 (4.7-5.6)	7.2	0.5 (6.4-8.4)	7.8	0.4 (4.5-5.5)
SGOT SF units	C	32.0	7.1 (19-55)	5.6	0.2 (5.4-5.9)	4.3	0.4 (3.6-5.0)	5.2	0.4 (5.4-6.1)
ALK. P-TASE KBR units	E	2.4	0.9 (0.8-5.0)	5.5	0.1 (5.3-5.6)	40.0	29.3 (18-138)	5.2	0.2 (5.6-6.1)
TOT. P mg%	C	6.4	0.5 (5.4-7.4)	5.8	0.7 (6.9-5.2)	55.0	20.3 (26-120)	7.6	0.3 (7.5-8.1)
LDH Cabaue-Wroblewski units	E	144.0	74.4 (70-520)	6.2	0.3 (5.7-6.7)	30.3	4.6 (20-38)	7.6	0.1 (7.5-7.7)
	C	190.0	30 (160-220)	4.2	0.4 (3.8-4.8)	5.3	1.3 (2.6-7.7)	5.2	0.2 (5.0-5.5)
	E	269.0	58 (190-390)	4.0	0.3 (3.6-4.4)	5.4		5.2	0.3 (4.8-5.5)

DOGS

MONKEYS

TEST	GP	PRE-EXPOSURE			230-DAY EXPOSURE			PRE-EXPOSURE			230-DAY EXPOSURE		
		Mean	S.D. -Range	Mean	S.D. -Range	Mean	S.D. -Range	Mean	S.D. -Range	Mean	S.D. -Range		
HCT	C	43.0	2.4 (39-48)	49.8	2.9 (45-52)	38.0	2.4 (35-45)	45.5	1.5 (44-47)				
%	E			46.2	2.0 (43-49)			39.2	2.6 (36-43)				
HGB	C	14.0	0.9 (12.3-15.7)	17.0	0.9 (15.6-18.0)	11.2	0.6 (10.3-12.7)	15.2	0.8 (14.4-16.0)				
gm%	E			14.9	0.7 (14.0-16.0)			13.2	1.0 (12.0-14.8)				
RBC	C	4.3	0.4 (3.7-5.6)	6.4	0.5 (5.85-6.88)	4.0	0.3 (3.4-4.5)	5.5	0.0 (5.52-5.55)				
x 10 ⁶	E			6.2	0.3 (5.72-6.57)			5.0	0.3 (4.59-5.43)				
WBC	C	11.8	2.1 (8.1-17.6)	13.5	2.0 (11.0-16.0)	13.5	2.3 (9.0-17.1)	19.0	1.5 (17.5-20.5)				
x 10 ³	E			12.8	2.4 (8.6-16.9)			12.6	1.4 (10.6-14.4)				
SODIUM	C	145.0	2.4 (140-151)	146	1.5 (144-148)	149.0	3.9 (144-158)	144	0.5 (143-144)				
meq/liter	E			143	1.8 (140-144)			143	1.8 (140-145)				
POTASSIUM	C	4.9	0.2 (4.4-5.4)	5.2	0.3 (4.9-5.5)	5.0	0.5 (4.1-6.2)	5.3	0.3 (5.0-5.6)				
meq/liter	E			4.7	0.3 (4.4-4.9)			4.6	0.5 (3.6-4.8)				
CALCIUM	C	5.6	0.2 (5.2-6.0)	5.8	0.2 (5.5-6.0)	5.8	0.4 (5.1-6.3)	5.8	0.0 (5.8-5.8)				
meq/liter	E			5.6	0.1 (5.3-5.7)			5.4	0.1 (5.2-5.5)				
TOT.	C	5.4	0.3 (4.7-6.0)	6.0	0.6 (5.2-6.7)	7.2	0.5 (6.4-8.4)	7.9	0.2 (7.7-8.1)				
PROTEIN	E			6.0	0.3 (5.3-6.5)			7.5	0.3 (7.1-7.9)				
gm%	C	3.4	0.2 (2.4-4.0)	3.9	0.2 (3.6-4.3)	4.3	0.4 (3.6-5.0)	5.0	0.2 (4.8-5.1)				
ALBUMIN	E			3.5	0.2 (3.2-3.9)			4.5	0.3 (4.1-5.0)				
gm%	C	23.0	8.1 (7-35)	29	3.7 (25-35)	40.0	29.3 (18-138)	30	1.5 (28-31)				
SGPT	E			35	6.3 (25-46)			26	9.1 (10-31)				
SF units	C	32.0	7.1 (19-55)	31	5.7 (26-40)	55.0	20.3 (26-120)	62	12 (50-74)				
SGOT	E			32	7.8 (22-45)			38	7.9 (26-45)				
ALK.	C	2.4	0.9 (0.8-5.0)	0.35	0.2 (0.2-0.6)	30.3	4.6 (20-38)	19	10 (9-29)				
P-TASE	E			0.32	0.2 (0.1-0.6)			15	5.5 (8.2-21.5)				
KBR units	C	6.4	0.5 (5.4-7.4)	5.5	0.5 (4.9-6.3)	5.3	1.3 (2.6-7.7)	4.7	0.2 (4.5-4.9)				
TOT. P	E			3.7	0.5 (3.3-4.9)			5.7	1.1 (4.5-7.0)				
mg%	C	144.0	74.4 (70-520)	355	83 (280-480)	354	162 (180-850)	610	130 (480-740)				
LDH	E			175	26 (160-220)			528	154 (340-740)				
Cabeau- Wroblewski units													

DISCUSSION

DR. THOMAS: I would like to make a comment in connection with your paper. This work required a horrible laboratory work load and, if you remember, during our first Conference, we tried to develop a "minimum standard" philosophy, just what should be done so we don't miss the boat. Well, the last year we did 40,000 clinical laboratory tests and in 99% of the cases the net result was negative, which perhaps is a comfort to know, but we start wondering whether we are using our manhours in a reasonable fashion.

DR. COULSTON: I do the same thing because I don't know any other way to do it, and I wonder. This is the same problem and this is the point at issue. We are coming very fast to the end of our rope here and we need a whole new kind of clinical assay in our modern sophistication to find changes we're trying to find. It doesn't mean we shouldn't do this. It doesn't mean we don't count the dead ones; we must count the dead ones. We must do all these other things because we don't know what else to do.

DR. BACK: One point, it is extremely difficult to do punch biopsies at altitude, but we are looking to the day when we will do this routinely. In our future construction plans, I'm looking forward to having an operating room built between the air locks. Then we can do this at altitude by pulling animals out of the cage, bringing them down into the operating room without disturbing the atmospheric pressure and composition, and bringing them back up again into the dome.

Capt. Kaplan is doing similar work now. It's extremely difficult the way we're set up to do it. We are doing punch biopsies. Unfortunately, we lost our first run in the middle of it; but we are doing this in one experiment now, and we hope to do it in monkeys and dogs in other experiments.

DR. COULSTON: I think that would be wonderful.

DR. FAIRCHILD (U. S. Public Health Service): I would like to suggest that maybe you are just looking at some of the wrong parameters. There have been some reports, of course, in more acute levels of toxicity, where they show the tie-in definitely, like changes in brain serotonin. This was reported by Columbia University at the Federated Society Meeting so I wouldn't say we should throw out looking at everything and give up altogether.

DR. BACK: I'm talking about serum enzymes and you obviously can't do brain serotonin while these animals are living. I'm talking here about serum enzymes and other blood tests during exposure, not what we find on sacrifice. Tissue enzymes, that's where we want to go.

MR. BROOKSBY (NASA Ames Research Center): Is anybody within the organization, in connection with these long-term studies, doing any pulmonary physiology measurements such as compliance in these lungs, carbon dioxide, maybe oxygen diffusion capacities, to get some indication what physiological shape the lung is in?

DR. BACK: Not in these experiments. We have too much to do just to keep them going for 8 months; but we want to do this kind of thing and we are also asking other people to do this. When we get more dome space we will do it ultimately. This is very important. No one has ever done pulmonary studies at altitude so far.

PATHOLOGY OF ANIMALS EXPOSED TO A PURE OXYGEN ATMOSPHERE AT REDUCED PRESSURE FOR PROLONGED PERIODS

David T. Harper, Jr., Captain, MC, USAF
Farrel R. Robinson, Major, VC, USAF

Aerospace Medical Research Laboratories
Wright-Patterson Air Force Base, Ohio

INTRODUCTION

As part of comprehensive toxicological evaluation of the 258 mm Hg (5 psia) 100% oxygen atmosphere presently used in manned spacecraft by the National Aeronautics and Space Administration, dogs, monkeys, rats, and mice were exposed continuously to this atmosphere for periods up to 92 days in the new Thomas Domes at Wright-Patterson Air Force Base. These domes are large automated dynamic flow altitude chambers, capable of maintaining atmospheres of reduced pressure and altered gas composition continuously over prolonged periods while allowing animal maintenance and removal through an air lock. This report concerns the pathologic findings in this study; techniques of maintaining the chambers and a report of clinical data are presented in separate papers.

METHOD

Purebred beagle dogs weighing 12-20 lb, Macaca mulatta monkeys weighing 7-12 lb, Wistar rats weighing 75-175 grams, and male Harlan mice weighing 25-30 grams were used. Dogs and monkeys were of both sexes in equal numbers. Those rats used for controls and the 14-day exposure were also of both sexes, but rats exposed for 28, 60, and 92 days and all mice were males. Up to eight clinical laboratory baselines were determined on large animals and after stability had been achieved, all animals were placed in the Thomas Dome for a 12-day preconditioning period at ambient conditions. The chamber was then purged with 100% vaporized liquid oxygen for 1.5 hours and exhausted over a period of 2 hours to a simulated altitude of 27,500 feet (258 mm Hg). Thereafter, vaporized liquid oxygen, after suitable pressure reduction, entered the 870 cubic foot chamber at 20 cfm. The gaseous environment was continuously exhausted under vacuum at the same rate. Animals were maintained under these conditions for periods of 14, 28, 60, and 92 days. Except for unscheduled recompressions (see Results), the environment was maintained between 240 and 280 mm Hg total pressure, 93.5 and 99.8% oxygen, 40 and 60% humidity, 70 and 78 degrees F. Continuous CO₂ analysis was accomplished by a Lira Infrared Analyzer and levels were maintained between 0.05 and 0.5%. Oxygen concentration was indicated continuously by polarographic sensors in the gas feed lines, daily by paramagnetic sensor carried by dome entrants, and by gas chromatography on samples taken from within the chamber and air lock. Biological contaminant levels were periodically sampled but at no time were detectable levels of hydrogen sulfide or ammonia found.

Within the dome, one or two monkeys occupied individual wire cages. Up to five dogs were free to move about in 5 by 6 foot raised wire pens. Rats and mice were caged in groups of 10 to 20. Control rats and mice were concurrently provided

similar caging in the adjacent animal holding room for periods of 14 and 90 days. Dogs and monkeys from the same suppliers were later sacrificed as controls. All animals and cages were serviced daily, with pelleted food and water provided ad libitum. All entries were made through an air lock to prevent disturbing the environmental conditions of the experiment in progress.

Dead animals were retrieved within 1 hour of the time of death as necessary, often several times daily. They were brought to ambient conditions through the air lock and immediately either necropsied or placed in a refrigerator (34 F) for periods up to 6 hours until necropsied. No differences in histological appearance were noted in tissues of animals kept refrigerated for these periods. Except for five rats kept for 7 days in ambient air after the 92-day exposure, all animals surviving the experiment were sacrificed immediately upon being brought to ground level through the air lock, using an overdose of pentobarbital intravenously for dogs and monkeys, and inhaled ether for rats and mice. Complete necropsies, including brain and spinal cord, and histological evaluations were performed on all dogs and monkeys. Specimens from heart, lung, liver, kidney, and spleen were taken from all rats and mice, but due to the large number of animals involved only representative cases were examined histologically. The numbers of cases examined are shown in tables III and IV.

Histological specimens were fixed in neutral buffered formalin, dehydrated and embedded in Paraplast*, sectioned at 5 micra and stained with hematoxylin and eosin. Frozen formalin-fixed tissue was stained with Oil Red O for fat. Special stains were used on occasion to demonstrate particular structures.

RESULTS

Course of the Experiment

Prescribed experimental conditions were maintained except on the following occasions. On day 4 entry hatch repair necessitated a recompression with 100% oxygen to 740 mm Hg (ambient pressure for Dayton, Ohio) for 3 hours. On day 39 vacuum pump failure resulted in entry of ambient air and recompression to 740 mm Hg for 1 hour. On day 59 inadvertent shutdown of the instrument air compressor caused a recompression with air to 740 mm Hg for 1.5 hours. On day 91 a similar compressor failure caused a partial recompression with air to 520 mm Hg for 30 minutes. Daily entries of animal care personnel into the chamber and the introduction from time to time of additional animals for other experiments did not affect the environmental conditions.

Clinical Appearance of Animals

Clinical observation did not indicate morbidity in any species. Rats and mice dying appeared to do so suddenly and without antecedent lethargy, ruffling or irritability. There was little yellow discoloration of the hair or exudate about the nares, mouth or eyes, except terminally. Rodents tended to be cannibalistic toward their cage mates soon after they died.

*56 to 57 C melting point (manufactured by Biological Research Inc.)

Mortality

No dogs or monkeys died. No rats or mice died in the 14- and 90-day control groups in room air. Cumulative mortality for exposed rats is shown in figure 1. There were 2 deaths (male rats only) on each of days 5, 6, and 12 of exposure among 38 rats exposed for 14 days; single deaths on days 3 and 4 among 10 rats exposed for 28 days; a single death on day 4 and 2 deaths on day 50 among 10 rats exposed for 60 days; and single deaths on days 2, 4, 11, 13, 14, 2 deaths on day 45, and 1 death each on days 52 and 73 among 40 rats exposed for 92 days. Forty mice exposed for 14 days, 10 for 28 days and 40 for 92 days all survived. Of 11 mice exposed for 60 days, two died - one on day 54 and another on day 56.

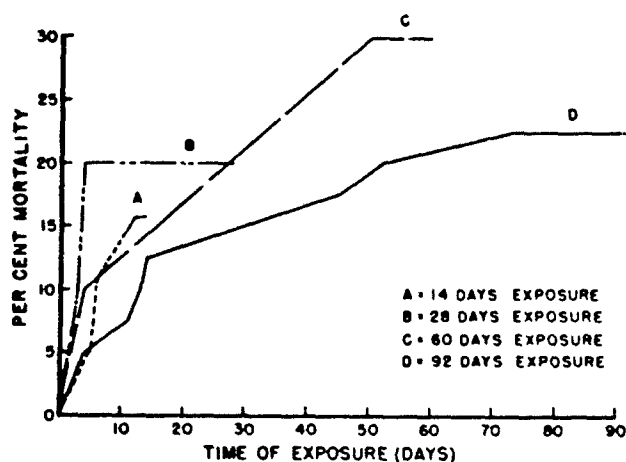

Figure 1. 5 PSI OXYGEN EXPOSURE, RATS

Gross Pathological Findings

Dogs: A few gray, firm, 3-5 mm nodular lesions scattered over the pleural surfaces of the lungs were observed in 50% of the 14-, 28-, and 60-day groups, and in 100% of the 4 dogs exposed for 92 days; only one of six control dogs had a single such lesion on the dorsal right apical lobe. These lesions appeared in some cases to be focal subpleural emphysema or alveolar septal thickening, but this could not regularly be confirmed histologically. Focal hemorrhages at the lung bases were seen in both dogs sacrificed after 28 days of exposure, and one had a hemorrhagic, consolidated lingula. Tiny red lesions on the visceral pleural surfaces thought to be minute hemorrhages were observed in one dog after 60 days. Hemorrhage into one middle ear (attributed to the recompression 10 days earlier during the hatch repair) was present in one dog after 14 days exposure. Numerous white scars on

the kidney surface, later confirmed histologically to be chronic nephritis, were seen in two dogs, one after 14 days and one after 92 days exposure.

Monkeys: Mottling and focal hemorrhages at the lung bases were evident in one monkey after 28 days, one after 92 days exposure, and one control animal. Green nodular pulmonary lesions of *Pneumonyssus simicola* were demonstrated grossly in 11 of the 18 monkeys used in this study in both exposed and control groups. Three of these animals had fibrous pleural adhesions indicating severe disease in the past.

Rats: Eight rats dying during exposure had been cannibalized. Ten others showed maroon, heavy, wet, and edematous lungs which were uniformly consolidated. Two other rats dying at 45 and 52 days during the 92-day exposure demonstrated extensive pneumonitis and pulmonary consolidation; the former had a far-advanced lung abscess. Sacrificed rats had red or gray mottled lungs in 4 cases after 14 days, 2 after 28 days, one after 60 days, and one after 92 days. Four rats sacrificed after 60 days and one after 92 days showed patches of dense white pleural thickening, most pronounced posteriorly. Excessive fluid in the pleural space was not found. Throughout the study, 13 rats were examined for hemorrhage in the middle ears and 7 showed it; all but 2 (sacrificed after 28 days) had died during the exposure. No gross lesions were seen in the remaining 28 rats after 14 days, 6 rats after 28 days, 3 rats after 60 days, and 29 rats after 92 days of exposure. One of 50 control rats after 14 days showed mild pulmonary congestion. One of 20 controls after 90 days revealed a florid pneumonitis with consolidation of one lung and compensatory emphysema of the contralateral lung.

Mice: Two mice died in the 60-day group; both showed the same dark, heavy, wet, red lungs that had been seen in the rats that died. Most surviving mice showed no gross lesions. In the 14-day exposure group, two had hemorrhage in the middle ears and one had diffuse gray-red discoloration of lung tissue. Almost 50% (18/40) of the mice after 92 days showed slight to moderate diffuse gray or red discoloration of the lung.

Histological Findings

Dogs: Many lesions (table I), such as subacute and chronic pneumonitis, acute interstitial pneumonitis, focal acute alveolar exudates, acute suppurative and subacute serous bronchitis, hard granulomas with necrotic centers surrounded by intense chronic inflammatory reaction, and lung parasites were either found in controls as well as in exposed animals or were scattered irregularly among exposed groups and thus were not thought to be related directly to the experimental protocol as such. Focal hepatic inflammation, either periportal or randomly placed, was observed in both exposed and control groups; many of these lesions surrounded suspicious eosinophilic or dark globose hepatocytes, but no unequivocally necrotic cells could be identified. No excessive liver fat was noted on four Oil Red O stains in exposed animals. Several exposed and control animals showed chronic pyelitis or smouldering or scarred interstitial nephritis, obviously of considerable duration.

Changes which could possibly have had some relation to the exposure included an increased incidence of pneumonitis noted in the 60- and 92-day groups; bronchial smooth muscle hypertrophy, congestion, and hemorrhages seen in both

animals after 28 days but not at 60 or 92 days; instances of bronchiolar mucosal metaplasia (dedifferentiation of columnar lining cells into squamous or pseudostratified layers) and alveolar septal widening with appearance of an increased number of interstitial mononuclear cells. observed after 14-92 days only in exposed animals. Some of these lesions were quite striking in intensity, but none showed a clear-cut relationship to duration of exposure.

TABLE I
5 PSIA OXYGEN EXPOSURE, DOGS

	<u>14-Day</u>	<u>28-Day</u>	<u>60-Day</u>	<u>92-Day</u>	<u>Control</u>
ANIMALS USED	2	2	6	4	6
LUNG:					
Pneumonitis			4	2	1
Smooth Musc. Hypertrophy		2			
Congestion		2			
Hemorrhage		2			
Mucosal Metaplasia	2	1	1		
Alv. Septal Thickening	2	1	2	2	
Edema & Alv. Exudate					2
Interstit. Pneumonitis	1				2
Pulmonary Granuloma	1				
Bronchial Inflammation	1		2		2
Lung Parasite		1			1
LIVER:					
Focal or Periportal Inflammation		1	1	1	2
Excessive Fat/ Number Examined	0/1		0/1	0/2	
KIDNEY:					
Nephritis	1		1	1	
Pyelitis			3		1

Monkeys: No unequivocal differences were observed between exposed and control groups of monkeys (table II). Lesions included hemorrhage and moderately severe pulmonary congestion, focal alveolar edema, alveolar septal thickening with increased numbers of mononuclear cells, infestation with Pneumonyssus simicola, focal hepatic inflammation and chronic nephritis. One case of patchy pneumonitis, two cases of chronic bronchial inflammation with mucosal eosinophilia and a suppurative liver abscess without any additional hepatic manifestations were observed in the longer-term exposed groups. No significant vacuolization of liver cells was seen in any animal and a fat stain after 14 days exposure did not show excessive liver fat.

TABLE II
5 PSIA OXYGEN EXPOSURE, MONKEYS

	<u>14-Day</u>	<u>28-Day</u>	<u>60-Day</u>	<u>92-Day</u>	<u>Control</u>
ANIMALS USED	2	2	2	4	8
LUNG:					
Congestion		1 (1)*			2 (1)
Hemorrhage					2
Edema		1			1
Pneumonitis			1		
Alv. Septal Thickening		1		1	1
Bronchial Inflammation			1	1	
Lung Mite Disease		1	1	3	3
LIVER:					
Inflammation (Focal)		2	1		5
Excessive Fat/ Number Examined	0/1				
Abscess				1	
KIDNEY:					
Nephritis	2			1	7

*(Number in parentheses indicates cases in which lesion was moderately severe or severe)

Rats: (table III) Rats dying during exposure which had not been cannibalized by their cage mates uniformly showed diffuse extreme pulmonary capillary congestion with a markedly eosinophilic gross appearance of the lung section. Surviving animals never showed this extreme congestion. Moderately severe congestion was present in many surviving exposed and 90-day control animals, and minimal congestion was present in all animals (probably due to ether anesthesia). In all fatal cases examined, almost every alveolus was filled with edema fluid, scattered alveolar lining cells and erythrocytes. Only one surviving animal showed moderately widespread alveolar edema, and no proteinaceous edema fluid was stained in any control rat lung. No surviving or control animal showed more than a few focal hemorrhages, often quite fresh and possibly related to necropsy trauma. Acute polymorphonuclear leukocytic alveolar exudate was seen in eight fatal cases, in three of which it was moderately severe and widespread. Minimal exudate was seen in five surviving exposed rats. None was seen in controls. A striking example of PAS positive alveolar membrane formation appeared in a rat dying after 5 days of exposure. This lesion was quite widespread and was associated with congestion, moderately severe alveolar hemorrhages and edema.

Pulmonary infectious disease was present in 100% of the rats used in this study. Most rats demonstrated only small peribronchial or perivascular

TABLE III
5 PSIA OXYGEN EXPOSURE, RATS

	14-Day		28-Day		60-Day		92-Day		90-Day	
	SURV	FATAL	SURV	FATAL	SURV	FATAL	SURV	FATAL	SURV	Control
TOTAL ANIMALS USED	50	38	10*	10*	10*	40*	20*	20*	20*	20
SURVIVORS	50	32	8	2	7	31	7	9	6	10
DEATHS	-	6*	-	3	2	9	-	-	-	-
HISTOPATHOLOGY	-	3	10	3	7	15	-	-	-	-
LUNG:	SURV	FATAL	SURV	FATAL	SURV	FATAL	SURV	FATAL	SURV	SURV
Congestion	7	3(3)**	9(1)	2(2)	7(4)	6(5)	14(10)	6(5)	9(7)	5
Hemorrhage	6	3(1)	4	1	3	1	8	3	8	5
Edema		3(2)	3	2(2)	3(1)	6(4)	2	6(4)	2	
Alveolar Exudate		1		2	3	5(3)	2	5(3)	2	
Alveolar Membranes		1(1)								
Murine Pneumon. Synd.										
Lymphocytic Nodules	11	3	10	2	7	6	15(1)	6	10	
2 Eos. Perivasc/										
Bronchitis	3	2	8(1)	2	5(1)	5(3)	8(4)	2	7	1
3 Pneumonitis										
Interst. Pneumonitis		1				1		1		
Bronch. Inflammation						1		1		
Alveolar Sept. Thick.	6	5	3	2(1)	4	7	7	2(1)	7	1
Mucosal Metaplasia		1					1		1	
Pulm. Arterial Edema		7	6	1	6	1	8	1	8	1
Atelectasis	5	2	2				9		9	
Emphysema	1						1		1	
LIVER:										
Focal Inflammation	5	5	1		4	1	6	1	2	
Focal Necrosis		1					1		1	
Vacuolization	1	1	3		1	1	1		1	
Excessive Fat/										
Number Examined	0/2	0/2	0/2							
HEART:										
Myocardial Information					1				1	
Focal Necrosis									1	

TABLE IV
5 PSIA OXYGEN EXPOSURE, MICE

	14-Day Control	14-Day	28-Day	60-Day	92-Day
TOTAL ANIMALS USED	40	40	10	11	40
SURVIVORS	40	40	10	9	40
DEATHS	0	0	0	2	0
HISTOPATHOLOGY	5	5	5	5	5
				<u>FATAL</u>	<u>SURV</u>
LUNG:					
Congestion	4	5	5(1)*	2(2)	5
Hemorrhage	1	4	1	1	1
Edema				1	1
Alveolar Exudate				1	1
Interstitial Pneumon.				1	1
Alveolar Sept. Thick.	3	4	2	5	5
Lymphocytic Nodules	3	1		4	1
Pneumonitis				1	
Atelectasis	3	2	1	3	1
Pulm. Arterial Edema		3	1		
LIVER:					
Vacuolization	1		3	1	2
Excessive Fat/ Number Examined	0/2	0/1			
Focal Inflammation	1			3	2
KIDNEY:					
Nephritis	3			1(1)	2

*(Numbers in parentheses indicate cases in which lesion was moderately severe or severe)

lymphocytic accumulations, but large numbers of exposed animals also showed edentous eosinophilic and mononuclear cell cuffs surrounding vessels and larger bronchi and in the perihilar interstitium. In 9 of 51 exposed rats examined, this lesion was severe and uniformly present around every major vessel and airway, whereas only 3 of 21 control animals examined showed even minimal eosinophilia around vessels. Actual consolidative pneumonitis (including dense eosinophilic perivasculitis with purulent exudate filling bronchial lumina) was seen in nine cases in the 92-day exposed group, and involved whole lobes, entire lungs or large portions of both lungs. Two of these rats had died at 11 and 45 days respectively. Two of five rats held in room air for 7 days after 92 days exposure showed pneumonitis and eosinophilic perivasculitis; this was not significantly different from the proportion in rats killed immediately after exposure. One case of pneumonitis also appeared in the 90-day control group.

Other manifestations of infectious disease included diffuse acute interstitial pneumonitis observed in two exposed rats and acute bronchial inflammation with neutrophils dissecting through the mucosal columnar cells observed in four rats exposed for 92 days and in one rat in the 90-day control group.

Alveolar septal widening with influx of mononuclear cells appeared in about 50% of the rats examined in all exposed groups and in the 14-day control group but in only one animal in the 90-day control group. This lesion was focal in distribution and was moderately severe in one case. Bronchiolar mucosal metaplasia was observed in two experimental animals.

Widespread edema and vacuolization of pulmonary arterial medial tissue which did not show fat when stained specifically, appeared in 70% of exposed animals examined but was not seen in controls.

Atelectasis, usually very limited in its distribution, was seen in survivors in almost every group. Mild vesicular emphysema was seen in two animals but was felt to be due to postmortem manipulation (although lungs were not distended before fixation).

Focal inflammation in liver appeared in all groups and in two exposed rats was associated with unequivocal focal hepatocellular necrosis. Animals in most groups showed mild diffuse or centrilobular hepatic cell cytoplasmic vacuolization, but no excess fat was found in Oil Red O stains on tissue from both exposed and control rats.

Focal scarring of myocardium was seen in two exposed rats. In one sacrificed after 92 days, this was associated with widespread acute myocardial necrosis with suppurative reaction in a rat with consolidative pneumonitis.

Mice: Most exposed and control mice showed mild congestion and dilatation of lung capillaries, but only the two mice dying in the 60-day group showed extreme congestion (table IV). In one mouse this was associated with moderate patchy alveolar hemorrhages, patchy alveolar edema, and acute alveolar infiltration of polymorphonuclear leukocytes; in the other, with florid acute interstitial pneumonitis. A large proportion of mice examined in all groups showed focal alveolar septal widening with increased numbers of mononuclear cells. Chronic inflammatory disease as represented by peribronchial lymphocytic nodules also appeared

frequently, and one mouse showed frank suppurative pneumonitis, seen after 60 days exposure. Focal atelectasis was seen in the early part of the study. Edema of pulmonary arterial medial tissue was seen in 8 exposed animals, but not in controls.

Mild liver cell vacuolization was seen in one control animal, and several times among exposed animals. Three Oil Red O stains failed to reveal any excess fat. Focal hepatic inflammation appeared in roughly the same proportions but no clear-cut hepatic cell necroses could be identified. Nephritis was observed in both exposed and controls. One mouse dying on day 56 of a 60-day exposure showed extremely severe nephritic lesions with formation of renal abscesses.

DISCUSSION

All species used in this exposure demonstrated sublethal pathology, but for the most part, these lesions were either distributed between exposed and control groups or else were so scattered among groups of exposed animals as to preclude any indication of a dose-response relationship.

Dogs: No lesion was so distributed as to indicate a relationship to length of exposure. Most lesions appeared as well in controls, while smooth muscle hypertrophy of bronchial walls, pulmonary congestion and hemorrhage, and bronchiolar mucosal metaplasia appeared at most sporadically. Alveolar septal thickening was a clear-cut lesion appearing only among exposed dogs, but failed to appear often in animals sacrificed after 60 or 92 days, and thus bears an equivocal relationship to the exposure. Adaptation to this derangement during the later periods cannot be ruled out, but no evidence, such as interstitial fibrosis, cellular debris, or nuclear pyknosis, was found to suggest such a process.

Monkeys: Only one case of pneumonitis distinguished the groups of exposed monkeys from the control group, although both showed several instances of congestive, inflammatory and exudative lesions. No differences between exposed and control animals can be postulated.

Rats: Pulmonary arterial medial edema and vacuolization in rats clearly was confined to exposed animals and appeared in 55% of exposed rats examined. This lesion was present in fairly uniform proportions throughout the exposure period and thus displays only a crude dose response relationship. Because of the significant number of times it occurred and its absence among controls it must be recognized as a probable effect of exposure.

Two other lesions noted in exposed rats are mentioned for consideration as possible toxic effects which should be looked for carefully in the future, but which at this time cannot be attributed directly to the exposure. These are myocardial necrosis, either with or without accompanying inflammation, and focal hepatic necrosis with inflammation. The latter will be obscured by the endemic presence of periportal and midzonal focal inflammation which we have observed frequently in many strains of rats and which does not appear to be related to the overall health of the animals.

Infectious Disease:

The very high (100%) incidence of infectious disease among rats used in this study renders difficult any statement about degrees of this process related to exposure. Innes, et al (ref 1), have emphasized the widespread existence of the chronic murine pneumonia syndrome and Innes (ref 2) has discouraged the use of rats and monkeys in experiments involving pulmonary toxicity. It is clear that advanced stages such as florid edematous eosinophilic perivascularitis and frank pneumonia and suppuration not only occurred exclusively or much more commonly among exposed animals, but also appeared to increase in incidence and severity as the duration of exposure increased. There is published evidence that the incidence of severe degrees of murine pneumonia increases with age (ref 1) and this has been observed repeatedly in this laboratory. The relative absence of these lesions in 90-day control rats in this study, however, rules out the age factor as the sole determinant of the increase in exposed rats.

This difference is emphasized, moreover, by a consideration of the environmental conditions pertaining to exposed and control rats. While all rats were crowded, and the exposed rats perhaps more so, the temperature, humidity, and gas flow rate were relatively stable within the chamber, whereas rats in the animal holding facility were subject to the atmospheric vicissitudes of a heavily travelled large room, subject to changes in temperature and humidity into and out of which groups of animals were constantly being moved and in which surgical procedures were performed. The absence of significant advanced infectious pulmonary disease in the controls is, therefore, all the more striking.

The mechanism of this progression of preexisting infectious disease is not clear. Hypothetically, early injury to vascular or membrane integrity as a result of pressure changes, oxygen partial pressure changes, or one or more of the recompressions could have contributed to impairment of the normal host-parasite balance and exacerbation of the latent infection. There may be some evidence for the existence of these early sublethal changes in the varying degrees of congestion, hemorrhage, alveolar exudation and edema observed in sporadic cases among dogs, monkeys and rats. The same mechanism could conceivably have been the basis for lethality among rats and mice, as discussed below, but this cannot be proved.

This high incidence of infectious disease is inevitably a reflection on the current status of experimental animal procurement in this country. This experimental program was conceived in full awareness of the importance of using the most healthy animals available. It was hoped that by judicious selection of supplier careful culling of clinically ill animals and inferior shipments, and tender care of those animals selected, supplemented by repeated clinical laboratory baselines, would yield a relatively healthy and uniform population for this fundamental and important research program.

It was soon realized, however, that this goal is not currently attainable in the absence of a truly pathogen-free, inhouse animal breeding program. This realization has been reinforced by subsequent experience with other strains of rats, including so-called "Specific Pathogen Free" animals. The only conclusion that this laboratory can draw is that if open market procurement of experimental animals, such as rats, dogs, and monkeys, is conducted, the investigator must resign himself to a distinct limitation on the significance of results obtained during inhalation toxicological experiments.

Mortality:

Using mortality as a definitive endpoint, exposure apparently had a discernible effect in all groups of rats. Twenty of 98 exposed Wistar rats died, but none of 70 controls. Mortality rates ranged from 15.8% (6/38) in the 14-day group to 22.5% (9/40) in the 92-day group, with only six deaths occurring among the 60 rats in the chamber after the first 2 weeks of exposure.

A problem encountered in analyzing these results concerns the relation of deaths in rats to the four short recompressions occurring on days 4, 39, 59 and 91. Four rat deaths immediately followed the first incident, and although between days 2 and 4 there had been five deaths, all showing the same pulmonary pathology, the effect of this rise in total pressure with an oxygen concentration approaching 100% cannot be ignored. In this laboratory, oxygen at 1 atmosphere partial pressure has been found lethal to this strain of rats over periods of 48-72 hours, and although this recompressed period was quite short, its effect on lung tissue possibly altered by the previous exposure to altitude cannot readily be determined. Dickerson (ref 3) noted unexplained deaths among mature rats at 250 mm Hg 98% oxygen, apparently without any such changes in pressure. Work in this laboratory has suggested greater susceptibility of older rats to oxygen exposure but this has not been confirmed by others (ref 4). MacHattie and Rahn (ref 5) reported deaths in the early part of their experiment exposing mature (litter-bearing) mice to 197 mm Hg oxygen, and it is significant that they decompressed their chamber over a period of only 15 minutes. The three later recompressions in the present experiment differed from the first in that leaks of ambient air caused a fall in oxygen concentration as well as a rise in total pressure. They were not immediately followed by deaths in any species. Thus, the question still exists whether these or subsequent fatalities would have occurred if continuous pressure reduction had been maintained.

Interestingly, a subsequent 8-month continuous exposure did not produce this excess mortality among Sprague-Dawley rats, but in fact mortality was higher in the control group. This strain difference among rats in their resistance to oxygen/altitude exposure has been observed repeatedly in this laboratory and has been reported (ref 6). In the present study the mortality peak appeared much earlier than in Dickerson's (ref 3) work in mature rats, although he mentions respiratory disturbances within the first week at 250 mm Hg. All deaths in the 14-day exposed group were among the males although there was an equal number of females in this group. To our knowledge this sex difference has not previously been reported.

Rats dying during this experiment failed to show hyperpnea, nasal froth or exudate, or pleural fluid, supposedly the classic accompaniments of acute oxygen poisoning, leading one to question this mechanism as a primary cause of death. Two of the rats that died had shown overwhelming infectious disease and may have died from it; the relation to the environment of its development into a lethal lesion was considered above. All but two instances of hemorrhage into the middle ears found in rats were in animals dying during exposure; this lesion, both in man and in animals, has been associated with sudden pressure changes. The pulmonary lesions seen histologically in fatal cases are compatible not only with those of oxygen poisoning (ref 3, 7, 8, 9) but the combination of capillary engorgement, alveolar edema and exudate, and focal or widespread diapedesis of erythrocytes and hemorrhage is equally consistent with a vasomotor effect of changing pressure. Surviving rats and dogs showed congestion and focal hemorrhages, possibly an earlier

manifestation of this effect. On the other hand, one rat demonstrated progression to the stage of alveolar hyaline membranes, undoubtedly important as a cause of death; the relationship of this lesion to either oxygen or pressure effects is not clear.

Mice: This was the least affected species with regard to endemic disease, yet little was found that could be directly related to the exposure, because of the simultaneous appearance in controls of such changes as congestion, hemorrhage, alveolar septal thickening, lymphocytic nodules in lung tissue, atelectasis, vacuolization of liver cells, hepatic inflammation, and nephritis. Pulmonary arterial medial edema was again observed in exposed animals only, appearing in 36% of those examined. This lesion appeared entirely similar to that seen in rats.

The two deaths in mice in the 60-day group must be regarded as sporadic and do not have the same import as the proportion of deaths observed in all exposed groups of rats, although the histologic appearance of the lungs with the presence of inflammatory, exudative, and hemorrhagic lesions would indicate that the mechanisms were similar.

Thus, in spite of significant mortality among exposed rats, two deaths among exposed mice, and similar lesions in surviving rats and dogs, the importance of oxygen at this partial pressure as a toxic agent should be questioned. The work of Dickerson (ref 3) and MacHattie and Rahn (ref 5) also would indicate that oxygen may not be the most important factor.

REFERENCES

1. Innes, J. R. M., McAdams, A. J., and Yevich, P.: Pulmonary Disease in Rats, Amer. J. Path., 32:141-159, 1956.
2. Innes, J. R. M., "The Need for Critical Evaluation of Choice of Animal Species for Continuous Inhalation Exposure Experiments". In Proceedings of the Conference on Atmospheric Contamination in Confined Spaces, 30 March - 1 April 1965, AMRL-TR-65-230 (AD 629 622), Aerospace Medical Research Laboratories, Wright-Patterson AFB, Ohio, December 1965.
3. Dickerson, K. H.: Pathophysiology of Pulmonic Toxicity in Rats Exposed to 100 per cent Oxygen at Reduced Pressures, NADC-ML-6403, U. S. Naval Air Development Center, Aviation Medical Acceleration Laboratory, 1964.
4. Weir, F. W. et al.: Study of Effects of Continuous Inhalation of High Concentrations of Oxygen at Ambient Pressure and Temperature, Aerospace Med 36:117-120, 1965.
5. MacHattie, L. and Rahn, H.: Survival of Mice in Absence of Inert Gas, Proc. Soc. Exp. Biol. Med., 104:772-775, 1960.
6. Robinson, F. R., Harper, D. T., and Kaplan, H. P.: Selection of a Strain of Rats for the Study of Simulated Space Cabin Environments, Animal Care Panel, Philadelphia, 18 Nov 1965.
7. Armstrong, H. G.: The Toxicity of Oxygen at Decreased Barometric Pressures, Milit. Surgeon, 83:148-151, 1938.
8. Bean, J. W.: Effects of Oxygen at Increased Pressure, Physiol. Rev., 25:1-147, 1945.
9. Roth, E. M.: Selection of Space Cabin Atmospheres: Part I. Oxygen Toxicity, NASA TN D-2008, National Aeronautics and Space Administration, 1963.

DISCUSSION

DR. ROTH (Lovelace Foundation): What mechanism of death do you propose in your recompression studies with your mice and rats?

CAPT. HARPER: I'm not enough of an authority on the effects of pressure to say. We have seen dilatation of capillaries in both fatal cases and in the surviving cases, together with lesions that Maj. Robinson has shown, that is, exudation and hyaline membranes.

DR. COULSTON: I'm suggesting that would be a question for the forum. It will take a lot of answering and it's very important.

PATHOLOGY OF ANIMALS EXPOSED FOR 235 DAYS TO
A 5 PSIA 100% OXYGEN ATMOSPHERE

O. E. Hagebusch, M.D.

Laboratory for Experimental Biology
St. Louis, Missouri

The 283 animals used in this experiment consisted of rats, mice, monkeys, and dogs.* Of the 283, 74 were control animals which were exposed to room air, and 209 were experimental animals which were exposed to 258 mm Hg 100% oxygen for 230 days. A portion of the control and experimental animals were sacrificed at the end of the 230-day exposure while the remainder of both groups were kept for an additional 40 days at room air, and then sacrificed.

The report sheet shown in figure 1 was used to tabulate results. This provides for recording the severity, distribution, and type of lesions, and shows the method for coding observations.

A number of deaths occurred in both the control and experimental group before the completion of the experiment. These deaths will be listed in the summary of the findings according to species. Gross and microscopic examination of tissues from all animals was made at the completion of the study.

RATS: There were 100 rats used in this experiment.

CONTROL: Forty animals were used as room air controls. Twelve control animals died before the completion of the 230-day period. Sixteen were sacrificed at 230 days, while the remaining 12 were retained for an additional period. Two of this latter group died - one at 246 days and one at 247 days.

TREATMENT GROUP: Sixty animals were exposed to 258 mm Hg 100% oxygen. Only three animals died before the completion of the experiment at 230 days; one at 150 days, one at 180 days, and one at 187 days. Twenty-six animals survived and were sacrificed at the completion of the 230-day exposure, while the remaining 31 animals were allowed to remain at room air for an additional 40 days. There was no mortality in the 40-day recovery period.

All rats in these experiments showed pathologic alterations of the lungs. This was a manifestation of chronic murine pneumonia. There were no definite differences in degree, extent, or type of pathology between control and experimental animals and there were no lung changes attributable to the experimental conditions.

Myocardial pathology, consisting of various degrees of myocarditis, usually focal, was seen in both control and experimental animals. Its general type, extent, and severity was essentially similar in each group, approximately 18% of the room air controls (7 of 40 animals) showed this finding. It was not seen in any of the 12 room air controls kept for 270 days. The finding was considered not related to

Details of the experiment are included in the preceding papers by Dr. Back and Captain Harper.

experimental conditions as it was present in the controls and present to about the same extent in both experimental groups, i. e., those sacrificed immediately after exposure and those allowed to recover for 40 days.

Congestion of various organs, chiefly liver, spleen, and kidney, was present in approximately one-third of all animals. It was somewhat more prevalent in the experimental group which was subjected to reduced pressure for 230 days and allowed to recover for 40 days. However, a number of sections in this group showed autolysis and poor fixing; therefore, this finding was not considered significant. The increase in incidence was also thought to be small enough to be due to chance variation. Kidney pathology consisting of some form of nephritis, chiefly chronic pyelonephritis, was seen in three animals in each experimental group (6/60 or 10%). One animal in each of these two groups had a kidney tumor. In one instance, a tumor was found in a kidney showing evidence of pyelonephritis. No similar kidney changes (pyelonephritis) were seen in any of the controls. Because of the limited numbers of animals in the various groups, the incidence and statistical significance of this finding of kidney pathology in relation to experimental conditions is unresolved. It should therefore be considered and carefully watched for in further experiments at this level of oxygen exposure.

The presence of naturally occurring lung disease, chronic murine pneumonia, in all of the rats in this group makes subtle pathological changes very difficult to detect. It is of interest that in a previous experiment where 25 rats were subjected continuously to 30% oxygen at 700 mm Hg for 14 days, great difficulty was encountered in deciding whether significant lung pathology due to experimental conditions was present. The question was raised at that time concerning interstitial pneumonia. This lesion can be caused by extension and exacerbation of chronic murine pneumonia, but is also one of the rather early manifestations of oxygen toxicity.

In this group of studies it is impossible to make fine distinction on effect of treatment since the room air control group of rats had an inordinately high mortality (35% as compared with only 5% mortality in the oxygen treatment group). We have no indication of the cause of this high mortality. However, interpretations based on such controls must be made with great caution.

MICE: Of the 65 mice in this experiment 28 were control animals, 14 were kept at room air for 230 days and sacrificed, another 14 were kept at the same conditions and retained for another 40 days, and sacrificed. Of the 37 experimental mice exposed to 258 mm Hg 100% oxygen for 230 days, 16 were immediately sacrificed and 21 removed to room air for an additional 40 days.

In the control animals there were 5 deaths (18%) before the end of the experiment, one animal each dying on the 73rd, 120th, 164th, 182nd, and 197th day.

In the experimental group there were also five deaths during the exposure period, one animal dying at 1 day, one at 176 days, two at 181 days, and one at 227 days. There was no mortality during the 40-day recovery period.

All animals showed some pathological changes in lungs. For the most part this was mild and the more acute changes noted were considered to be extension and exacerbation of chronic lung disease essentially similar to chronic murine pneumonia in the rat. No differences could be detected among the four groups or between controls and experimental animals.

Kidney pathology consisting of chronic nephritis was seen in approximately the same incidence and to the same degree of severity in all four groups. The one case of acute nephritis occurred in the first experimental group, but this is not considered enough evidence to relate this to experimental conditions.

One case of myocardial pathology was present in the experimental group retained for 270 days. Although it was not seen in controls, this isolated finding is not considered significant.

No histopathologic evidence was noted that would indicate that exposure to 58 mm Hg of 100% oxygen for 230 days is toxic to mice.

MONKEYS: Six animals were used in this experiment. Two animals were sacrificed after 230 days at room air, two animals were exposed at 258 mm Hg 100% oxygen for 230 days and sacrificed and two other animals were exposed to the same conditions and then retained at room air for another 40 days.

All animals lived for the duration of the experiment.

Both control animals showed a chronic pyelonephritis, a finding present in only one of the four experimental animals. It is not considered related to the experimental conditions. In addition, one of the controls had evidence of a myocardial lesion, a finding not present in any of the four experimental animals.

Minimal lung changes were present in five animals. In two animals this was accompanied by lung mite disease and no significant lung changes were seen in experimental animals that were not seen in controls.

While the series is very small from which to draw valid conclusions, no stopathological changes were seen that would indicate that 258 mm Hg 100% oxygen for 230 days is toxic to monkeys.

DOGS: Twelve animals were used in this experiment. Two of the four controls were sacrificed after being kept in room air for 230 days and the remaining 10 were then retained for another 40 days and sacrificed.

Eight experimental animals were exposed to 258 mm Hg 100% oxygen for 230 days. Four were sacrificed at 230 days and the remaining four retained in room air for another 40 days.

The control animals showed no significant pathological changes. Of the animals exposed to 258 mm Hg 100% oxygen for 230 days, two of the series showed interstitial pneumonia and destructive emphysema. One of these experimental animals had most extensive pulmonary disease, including pulmonary fibrosis, acute bronchitis and bronchiolitis. The other two animals were essentially similar to the controls.

Of the four dogs exposed to 258 mm Hg 100% oxygen for 230 days and then kept at room air for 40 days, two animals showed mild interstitial pneumonia and one showed mild to moderate destructive emphysema. One animal was essentially similar to the controls. The pathology present was less acute and less severe than the group sacrificed at the conclusion of exposure. This suggests regression of the lesion and healing.

On the basis of this small group of animals, it is suggested that 258 mm Hg 100% oxygen for 230 days may be toxic for the dog. There was no evidence that this concentration was toxic for mice or monkeys under the same experimental conditions. The dog and rat microscopic sections were carefully reviewed by eight pathologists after the original findings had been recorded. This was done on a completely blind basis, no pathologist knowing what conditions the animal had been subjected to or what the previously recorded findings were. Aside from minor variations in degree of pathology thought to be present and some disagreement on the presence or absence of minor changes, all diagnoses were in agreement.

It is the considered opinion that when dogs are exposed to 258 mm Hg 100% oxygen for 230 days, pathological changes are present in the lungs. It is thought that subtle changes may be present in rats at this same exposure, but that more work is necessary before this can definitely be determined.

Acute pulmonary pathology which is considered to be related to experimental conditions consists of various combinations of hemorrhage, edema, congestion, bronchiolitis, mucous plugs, edema and inflammation about vessels, thickening and proliferation of alveolar walls, interstitial pneumonia, atelectasis, and bronchial pneumonia.

The temporal relationship of these changes appears to be as follows. The earliest changes noted are congestion, hemorrhage, and edema. Death supervenes if these changes are marked. Next, inflammation appears. It apparently begins in alveolar walls. In the mildest forms of the disease the inflammatory cells are more readily observed in the adventitia of vessels, probably in the lymphatic channels. In the mild to moderate interstitial pneumonia, bronchial epithelium seems to be spared. In its severe form, interstitial pneumonia causes marked swelling and proliferation of alveolar lining cells and a mononuclear cell infiltrate. This finding in some instances is sufficiently marked to obliterate alveolar spaces. Severe interstitial pneumonia and hemorrhage of several days duration presents a complex, severe pulmonary pathologic alteration which resembles those changes seen in the Hamman-Rich syndrome. In some instances, the muscularis of pulmonary arteries (small branches) appeared thickened. Whether this is due to edema or actual muscular hypertrophy has not been determined. Removal to room air for 40 days following the exposure appears to result in some apparent healing as the pathologic processes seen are less acute.

DISCUSSION

DR. FAIRCHILD (U. S. Public Health Service): I would like to ask once again, in view of your own work now, in animals sacrificed 40 days after these exposures was this alveolar wall thickening present in dogs?

DR. HAGEBUSCH: It was present in dogs, questionably so in rats, but to a lesser degree than in those sacrificed immediately after exposure. We felt there was a lessening of the pathological process and apparent healing. There was more fibrosis as well.

MR. BROOKSBY (NASA Ames Research Center): In regard to this thickening persisting in oxygen exposure, we found in rats exposed to pure oxygen at 600 mm for a period of a month and then removed from the oxygen that the alveolar thickening persists for as long as a month and a half after the animals have been taken out of oxygen.

DR. HAGEBUSCH: It did persist in some of them. We felt it was to a lesser degree than the others.

DR. COULSTON: I just want to say one thing about this paper. Many of you don't realize perhaps how difficult it is to present a paper of this sort and I want to personally compliment the speaker; he did a masterful job.

ELECTRON MICROSCOPIC INVESTIGATIONS OF OXYGEN EFFECTS ON LUNG TISSUE

Gonzague S. Kistler, M.D.
Ewald R. Weibel, M.D.

University of Zürich
Zürich, Switzerland

and

Peter R. B. Caldwell, Captain, USAF, MC

Aerospace Medical Research Laboratories
Wright-Patterson Air Force Base, Ohio

PART I

ELECTRON MICROSCOPIC AND MORPHOMETRIC STUDY OF RAT LUNGS EXPOSED TO 98.5 PERCENT OXYGEN AT ATMOSPHERIC PRESSURE

INTRODUCTION

The purpose of this study was to establish the time-sequence of changes occurring in the lung as a result of continued breathing of pure oxygen at atmospheric pressure. As the primary site of contact of oxygen molecules with tissue, the lung is particularly well suited for a study of the uncomplicated damaging effects of oxygen at elevated partial pressures, which occur in a relatively short time. Because of the requirements of breathing 100% oxygen for life support in aviation and space travel, a systematic evaluation of these effects appeared urgently needed.

At the outset of our study the following findings had been obtained by various investigators on humans and on laboratory animals (for a detailed review see ref 1).

Among the clinical symptoms of oxygen poisoning severe dyspnea prevailed. This correlates to the chief functional findings of a reduction of vital capacity (ref 2, 3, 4, 5, 6, 7) and of diffusing capacity of the lung (ref 7, 8), as well as to an observed decrease of the hemoglobin content of the blood (ref 3, 9, 10) apparently associated with hemolysis (ref 11, 12). Recent investigations have also revealed a change in the surface active properties of lung extracts in dogs (ref 13).

A large number of pathological findings were obtained on oxygen poisoned lungs; they can be grouped into three categories:

a. Observed changes in airway structure consisted mainly in atelectasis (ref 9, 12, 14, 15) and in an accumulation of exudate in the alveoli, which contained numerous red cells, leucocytes and macrophages (ref 2, 5, 14, 16, 17, 18, 19, 20). It

was partly fibrinous and occasionally appeared to form "membranes" on the alveolar walls (ref 14).

b. Among vascular changes hyperemia was observed by numerous investigators (ref 1). A massing of thrombocytes in lung capillaries, as well as a tendency of blood cells to agglomerate was also found (ref 14). Pratt has suggested that a proliferation of capillaries may occur (ref 21).

c. In the lung tissue a peribronchial and perivascular edema was observed with the light microscope (ref 14, 19). Electron microscope studies revealed a thickening of the alveolocapillary tissue barrier due to accumulation of fluid in interstitium and cells (ref 14). In addition, changes in organelles of alveolar epithelial cells appeared to occur, such as swelling of mitochondria (ref 22) and an increase in the number of "lamellated bodies" (ref 14).

In appraising all these studies we note that the pathological investigations were phenomenological in nature; that is, they were restricted to a thorough description of the different pathological observations made on tissue preparations. For this purpose these studies were done on "terminal" stages of "tolerable" oxygen exposure where the picture is striking. A systematic study of the time sequence of the development of pulmonary damage due to breathing pure oxygen was therefore indicated. Furthermore, the pathological studies quoted lacked quantitative information on extent and severity of the observed damages. In order to define the time sequence of events, and to indicate the influence that observed changes may have on the functional performance of the lung as a gas exchange apparatus, morphometric methods (ref 23, 24) were employed in the present study which availed itself of gross observation, light microscopy and electron microscopy.

EXPERIMENTAL DESIGN

The first experimental step involved the exposure of rats to an atmosphere of pure oxygen under controlled conditions. This was done in collaboration with the Aerospace Medical Research Laboratories at Wright-Patterson Air Force Base, Ohio, in one of their environmental chambers. After removal of the anesthetized animals from the chamber the lungs were immediately processed according to the scheme given below. The specimens were further evaluated in the Laboratory for Electron Microscopy of the Department of Anatomy, University of Zürich.

SPECIFICATIONS OF THE ENVIRONMENTAL CHAMBER USED

Chamber description (see figure 1)

The chamber at the Aerospace Medical Research Laboratories was cylindrical in shape, made of aluminum with a jacket of spun fiber glass aircraft insulating material. The volume of the main cell (experimental department) was 170 ft³.

The chamber atmosphere was recirculated through a closed circuit pump system with a flow rate of about 15 ft³/min at one atmosphere. The carbon dioxide concentration was maintained below 0.1% by adsorption in lithium hydroxide canisters. Odors were removed by activated charcoal in the canisters. Temperature

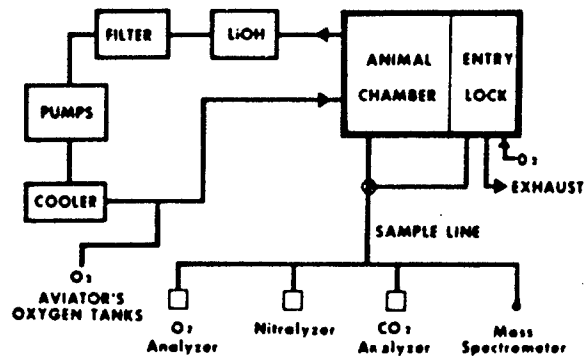

Figure 1. DIAGRAM OF ENVIRONMENTAL SYSTEM

and humidity were controlled by the cooler system. The oxygen source consisted of cylinders of gaseous aviators breathing oxygen, with minimum 99.5% concentration.

Sampling of the chamber atmosphere through the various analyzers was continuous, with the exception of the mass spectrometer analysis (see below).

All entries to the chamber were made through the entry lock in which atmospheric composition and pressure could be matched to that inside the main cell, thus avoiding contamination of the test atmosphere with nitrogen.

Controls concerning toxic contaminants

In a special study by the group at the Aerospace Medical Research Laboratories (ref 7), using a second but very similar chamber model, the chamber atmosphere was analyzed with respect to possible contaminants while operating under experimental conditions. A mass spectrometer analysis of room air and the chamber atmosphere showed them to be essentially the same with respect to trace gases. Furthermore, analyses for oxidants were made by the neutral buffered potassium iodide technique (ref 25) and for lithium with emission spectrography, because these substances are specifically toxic to the lung in concentrations smaller than might be detected by the mass spectrometer. Total oxidants were present in amounts of 0.1 ppm or less by volume. There was no ozone detectable by smell which probably means that ozone was not present in concentrations greater than 0.04 ppm by volume (ref 26). Nor was there any means of ozone production by either ultraviolet light or spark in this system. Lithium was present in concentrations of only 1 microgram or less per m³ of chamber atmosphere.

Since the same pumps were used in both chamber systems (chamber for the control of toxic contaminants and chamber for the experiments presented in this paper) we can conclude that there were no toxic contaminants present in sufficient concentrations to produce by themselves the effects observed after experimental exposure of the animals to 98.5% oxygen at one atmosphere. Thus, the respective tests done on the aluminum chamber used for the experiments presented here could be reduced to periodic checks by the mass spectrometer analysis of the chamber atmosphere. These have never shown the presence of any mass not also present in ordinary room air.

However, the possibility cannot be absolutely ruled out that in an atmosphere of 98.5% oxygen minor concentrations of oxidants or lithium may act synergistically with oxygen and play a role in the pathogenesis of the changes in pulmonary functions seen. The probability of such an interference can, however, be estimated as very minute.

OXYGEN EXPOSURE EXPERIMENTS

Exposure of rats to 98.5% oxygen at 765 mm Hg

Of 98 male Sprague-Dawley rats born on the same day, 73 were simultaneously exposed to 98.5% oxygen at one atmosphere ambient pressure. They were removed from the chamber in groups according to the following schedule:

Experimental group:	B 1	after	6	hours	in	chamber
	B 2	"	24	"	"	"
	B 3	"	48	"	"	"
	B 4	"	72	"	"	"

A group of 14 animals, kept in room air under otherwise identical conditions, were sacrificed as controls (CB) and processed in the same way as the test animals. A random sample of 11 rats had been sacrificed before the experiment as gross quality control (QB). Table I indicates that the homogeneity of the material used in this study was satisfactory.

TABLE I

CHARACTERISTICS OF ANIMALS USED IN STUDY

Group	Number of animals	Age at sacrifice days	Average body weight g	S. D. g	Murine pneumonia number of animals	% incidence
Q B	11	43	-	-	0	0
C B	14	44	122.6	2.5	1	7
B 1	18	47	116.0	0.7	1 (1)*	11
B 2	17	48	119.0	3.5	1 (1)*	12
B 3	17	49	123.0	1.3	0	0
B 4	24	50	102.4	6.0	0	0

* (1) - Questionable pneumonia

The incidence of murine pneumonia was slight. For the quantitative studies reported here only lungs were used which were free of any signs of this disease.

For these experiments at one atmosphere, the inside of the environmental chamber was pressurized 25 mm Hg higher than outside ambient pressure (740 mm Hg), thus ensuring that any possible leaks in the system were outboard. The main physical characteristics of the chamber atmosphere can be given as follows:

Total ambient pressure:	740 + 25 mm Hg
Oxygen concentration:	98.5% ± 1%*
Carbon dioxide concentration:	below 0.1%
Relative humidity:	46 ± 1%*
Temperature:	74 ± 2 F*

* The ± values represent one standard deviation.

Exposure of rats to 98.5% oxygen at 258 mm Hg

In the course of our work at the Aerospace Medical Research Laboratories a second experiment was performed, exposing a similar group of rats to 98.5% oxygen at 1/3 atmosphere ambient pressure. Their lungs were processed in the same fashion. The results obtained on this group will be reported later.

PREPARATION OF LUNGS

Fixation of lungs

At the end of each experimental series, the animals were deeply anesthetized by intraperitoneal injection of a body-weight-conform amount of pentobarbital, then brought out of the chamber, weighed, labeled, and immediately processed in the following way:

- a. Exposure of chest and trachea, tracheotomy.
- b. Puncture of chest and instillation of fixative (cold 2.5% glutaraldehyde in 0.03 M K-phosphate buffer, pH 7.4)* through a fine polyethylene catheter inserted into the trachea and fixed by ligature. The instillation fluid was prepared in burettes; at the start of flow the hydrostatic pressure was consistently standardized to 20 cm H₂O. Flow of fixative into the air spaces was allowed until equilibration. Under these conditions, the lungs were all inflated to their maximum extensibility in the chest cavity.
- c. Ligature of the trachea with the previously placed thread while withdrawing the cannula.
- d. Removal of lung and heart and immediate submersion in the same fixative solution for 2 hours.
- e. Dissection of heart and mediastinal tissue from the lungs.
- f. Measurement of the lung volume by fluid displacement**, using the fixative as immersion medium.

*In a preliminary study, the isotonicity of the solutions used was thoroughly tested on different rat tissues.

**A special test proved the accuracy of this method to be very satisfactory.

At the same time and under the same conditions, a few randomly sampled lungs were fixed as technical controls with 1% OsO₄ in 0.1 M K-phosphate buffer.

After fixation for two hours, the lungs were carefully sliced from top to bottom into alternately thick (3-5 mm) and thin (1 mm) slices. From this point on, two different standardized processing sequences were used:

Preparation of specimens for light microscopy

The thick lung slices were placed into fixative in labeled snap caps and carried to Zürich, where they were further processed according to the following schedule:

- a. washing in 5 changes of 0.11 M K-phosphate buffer for 5 days
- b. dehydration in graded ethanol
- c. double-embedding in celloidin-paraffin

From these blocks, histologic sections of ca. 8 μ were cut on a sliding microtome and stained with the standard procedures for Hematoxylin-Eosin, PAS, Goldner, and Elastin-van Gieson stains.

Preparation of specimens for electron microscopy

The thin slices of each lung were carefully cut into some 200 small cubes of approximately 2 to 3 mm³, and processed according to the following schedule***:

- a. washing in 3 changes of 0.11 M K-phosphate buffer for 2 hours
- b. postfixation in 1% OsO₄ buffered to pH 7.4 on ice for 90 minutes
- c. dehydration in graded ethanol
- d. embedding in Epon 812 according to the method of Luft (ref 27)

Sectioning of the Epon embedded specimens was done on a LKB Ultratome and on a Porter-Blum Ultramicrotome using a DuPont diamond knife. Section thickness was about 1000 Å; for special purposes thinner sections (500-600 Å) were also used. The sections were picked up on 150 mesh copper grids fitted with a thin Formvar film reinforced by carbon. They were contrasted by the lead citrate method of Reynolds (ref 28).

Preparation of specimens for histochemical studies

Some lungs of each experimental group were quick-frozen without prior fixation. The trachea of the anesthetized animal was tied with a string to avoid collapse of the lung. The chest organs were rapidly excised in toto and immersed in isopentane chilled to -140 C by liquid N₂. The frozen lungs were stored in liquid N₂ and used for histochemical enzyme studies, the results of which will be reported later.

***Processing took place at the Aerospace Medical Research Laboratories on the day of removal of the animals from the chamber.

MORPHOMETRIC METHODS

SAMPLING PROCEDURE

The total material resulting from the exposure experiments consisted of the lungs of all animals belonging to the respective experimental groups. Only a minute sample could eventually be investigated. Particular attention had thus to be given to a proper multiple stage sampling procedure.

Sampling of animals

Upon removal from the chamber all animals were consecutively numbered. The lungs were fixed as outlined above. Those lungs which showed typical signs of murine pneumonia on gross examination or accidental technical artifacts were eliminated and processed separately. The remaining lungs were renumbered consecutively. Eventually the first 5 lungs of each group were chosen for the quantitative studies reported here.

Sampling of specimens for light microscopy

All thick slices of the lungs (see above) were processed to celloidin-paraffin-blocks. For each animal these blocks were aligned in order of size, and a systematic sample of five blocks (every third block) was drawn; these blocks were sectioned and used for quantitative analysis in the light microscope. On the sections, the fields to be evaluated were systematically sampled by displacement of the slide by exactly 1 mm by means of a calibrated microscope stage.

Sampling of specimens for electron microscopy

The thin slices of all suitable lungs (see above) were cut into some 200 small cubes of 2-3 mm³ volume. In the course of further processing they became thoroughly mixed, so that a random sample of ten blocks could be picked for each animal; they were again consecutively numbered. The smallness of the block and their deep black color due to OsO₄-fixation made a biased sampling impossible. The remaining blocks were bulk-embedded as reserves.

For each of the five investigated animals per group the first five blocks were sectioned; the sections were mounted on copper grids. The position of the section was delineated on a master sheet on which each square of the copper grid was assigned a number. By means of a random number table six fields were selected in the electron microscope and electron micrographed at standard magnification on 35 mm film, irrespective of the content. Fields with technical defects were not recorded but replaced. All recorded fields were used for study. Details of this sampling method were described earlier (ref 23, 29). By this procedure, 30 electron micrographs were quantitatively evaluated for each animal, making 150 for each experimental group and for the controls. This gave a total of 750 random electron micrographs, based on 125 ultrathin sections.

STEREOLOGIC PRINCIPLES

All stereologic methods of measurement employed in this study have been reported earlier in detail (ref 23, 29, 30) so that only the essential points shall be stated here.

Volumetric analysis

The volume relationship between different components was estimated by differential point counting (ref 31). A lattice of P regularly spaced points is randomly placed on a section of the material to be studied. A number P_A of these points will be lying on sections of the component A .

The ratio

$$\frac{P_A}{P} = \frac{V_A}{V} \quad (1)$$

will be an estimate of the relative volume occupied by the component A , V_A being its absolute volume, and V the total containing volume.

Surface area measurement

If a linear probe of length L is randomly placed on a section of tissue the number of intersections N_A of this line with the surface of a component A is proportional to its surface area, S_A (ref 32). If the surface is contained in a volume,

$$S_A = \frac{2 \cdot V \cdot N_A}{L} \quad (2)$$

It is not necessary that the linear probe be very long; we can also distribute Q short lines of length z on the section whereby $L = Q \cdot z$.

Surface-to-volume ratio estimation

If a component A , contained in a volume, V , has an overall surface, S_A and total volume, V_A , then some information on its geometric properties can be derived from its surface-to-volume ratio. From eq. 1 and eq. 2 we obtain

$$\begin{aligned} \frac{S_A}{V_A} &= \frac{2V \cdot N_A}{L} \cdot \frac{P}{P_A \cdot V} \\ &= \frac{2P \cdot N_A}{L \cdot P_A} \end{aligned} \quad (3)$$

Dividing the linear probe of length, L , into Q short lines of equal length z , and using the $2Q$ endpoints of these lines as the P test points for volumetric analysis, eq. 3 becomes

$$\frac{S_A}{V_A} = \frac{4 \cdot N_A}{z \cdot P_A} \quad (4)$$

In this principle, which goes back to Chalkley et al (ref 33), the number of test line used does not enter into the relation anymore.

Estimation of arithmetic mean thickness of a tissue sheet (air-blood-barrier)

The average thickness $\bar{\tau}$ of a double-surfaced tissue sheet can be defined as the average tissue volume per surface area (ref 29); $\bar{\tau}$ can thus be obtained by inversion of eq. 4 to

$$\bar{\tau} = \frac{z \cdot P_T}{2 \cdot N_S} \quad (5)$$

where P_T is the number of end-points of the test lines of length, z , falling onto tissue, and N_S is the number of intersections of the test lines with both surfaces. The numerical coefficient is 2 instead of 4 because both surfaces contribute to N_S (compare ref 29).

Estimation of harmonic mean thickness of barrier

In appraising the properties of the air-blood barrier as a diffusion resistance for gases an estimate of its harmonic mean thickness has to be obtained (ref 23, 24, 29), which is defined as

$$\tau_h = \frac{\sum f_i}{\sum f_i \cdot \tau_i^{-1}}$$

where f_i is the frequency of a thickness τ_i . According to a principle developed in an earlier report (ref 29), τ_h can be estimated from the harmonic mean l_h of the random intercept length l , measured along randomly placed linear probes of infinite length from entry to exit point, by the formula

$$\tau_h = \frac{2}{3} \cdot l_h = \frac{2}{3} \cdot \frac{N}{\sum_{i=1}^N l_i^{-1}} \quad (6)$$

Counts

Counts of red cells and nuclei were carried out by counting the number n_A of their transections appearing within the test area of given size ($5.4 \cdot 10^{-4} \text{ cm}^2$) on electron micrographed sections. The number N_A of these structures contained in the unit volume of lung tissue could have been calculated by the formula of Weibel and Gomez (ref 23, 34) as

$$N_A = \frac{n_A^{3/2}}{\beta_A \cdot V_{VA}^{1/2}} \quad (7)$$

where β_A is a shape coefficient. However, we have abstained from this calculation, since we were only interested in comparing different experimental groups; and this could well be done by comparing the numbers of transections.

PRACTICAL APPLICATION

Stereologic analysis of sections in light microscope

The light microscope could be used to estimate on celloidin-paraffin sections the amount of damage caused to alveoli in more advanced stages of oxygen poisoning. This was done by volumetric analysis, as described above, using the Zeiss Integrating Eyepiece I, as proposed by Hennig (ref 31), together with a 20 x objective on a WILD M-20 Microscope.

Stereologic analysis of electron micrographs

Random fields of ultrathin lung sections were micrographed at constant magnification on a Philips EM 200 electron microscope. The recording material was 35 mm film which could accommodate all 30 micrographs obtained from the 5 sections of one test animal. In addition a calibration standard was also recorded on each strip. These negatives were contact printed on positive film. The positives thus obtained could be passed, frame by frame, through a small table projector unit especially constructed for this purpose. A mirror reflected the image on a screen made of frosted acetate foil between two glass plates. This screen was fitted with a suitable lattice of points and lines with which volume ratios, surface areas etc. could be estimated by simple counting, as outlined above.

For the measurement of intercept lengths of long random probes with the carrier, this lattice was replaced by a system of parallel lines, along which the intercept lengths, l , were measured with a logarithmic scale. This scale was chosen to minimize the error of measurement in the short values of l , which influence the harmonic mean most severely.

Differential counter

To facilitate and rationalize the recording of the large number of counts - in this experimental series alone, 130,000 points had to be differentiated, plus some 20,000 intersections with surfaces - a differential counter was constructed of small electrical units. Through a set of 10 microswitches the investigator could "feed the location of a point" into a particular unit, where this information was added to previously entered information.

STATISTICAL ANALYSIS OF DATA

For the present report a simple and rapid method of statistical evaluation has been used. Each quantitative information sought was calculated for each test animal individually, each animal being taken as a sample unit. (Variation among the subsamples such as sections or fields is presently not considered.) The parameter under consideration of animal j in group i being y_{ij} , the following group information was calculated, with 5 animals per group:

$$\bar{y}_i = \frac{\sum_{j=1}^5 y_{ij}}{5} \quad (8)$$

$$\begin{aligned} \text{S.D.}_i &= \frac{\sum_{j=1}^5 (y_{ij} - \bar{y}_i)^2}{4} \\ &= \frac{\sum y_{ij}^2 - \bar{y}_i \cdot \sum y_{ij}}{4} \end{aligned} \quad (9)$$

$$\text{S.E.}(\bar{y}_i) = \frac{\text{S.D.}_i}{\sqrt{5}} \quad (10)$$

All + values indicated in the tables are one S. E. (unless otherwise indicated). In the graphs the two brackets above and below the average point enclose two S. E.

The comparison of the different test groups was done by Student's t-test, using the following formulas, S_1^2 and S_2^2 being the variances of the two estimates:

$$S_d = \sqrt{\frac{N_1 \cdot S_1^2 + N_2 \cdot S_2^2}{N_1 + N_2}}, \quad N_1 = N_2 = 5 \quad (11)$$

$$t = \frac{\bar{y}_1 - \bar{y}_2}{S_d} \cdot \sqrt{\frac{N_1 \cdot N_2}{N_1 + N_2}} \quad (12)$$

The degree of freedom being $N_1 + N_2 - 2 = 8$

we find the following error probabilities:

$t > 1.86$	$P < 0.1$
$t > 2.31$	$P < 0.05$
$t > 3.36$	$P < 0.01$

It is realized that this test is relatively crude and that more information could have been ascertained by applying a multiple variance analysis. However, this time-consuming test is postponed until the results obtained on the second oxygen-exposure experiment at 1/3 atmosphere pressure are complete. The two experimental series will then be thoroughly tested and compared, applying an elaborate multiple variance analysis. It can be said, however, that this extended testing will reveal at least as much information as is presented here. Some points which only appear suggestive today may be proven to be factual.

RESULTS

DESCRIPTION OF DAMAGES OBSERVED

Gross findings at autopsy at end of exposure experiments

All animals showing typical gross signs of (endemic) murine pneumonia (see table) were eliminated from the test series because of pathological complications unrelated to - or only partially aggravated by - oxygen poisoning.

In each of the groups B1 and B2 one animal which showed signs of focal consolidation suspicious of pneumonia was also eliminated from the series for quantitative study, but prepared for light microscopic investigation. The lungs of all other animals of these two groups appeared grossly normal.

At transfer from the high oxygen atmosphere to room air most animals of the B3 group showed signs of dyspnea of varying severity. The pleural cavity contained in all cases some exudate, mostly yellowish but occasionally slightly hemorrhagic. The lung surface was mottled with dark and light patches of a few millimeters diameter.

The animals of the B4 group were severely dyspnoic when brought to room air; they were gasping and rapidly became cyanotic. Some animals died within a few minutes. Upon opening the chest large amounts of partly hemorrhagic pleural exudate were found in all cases. The mottling of the lung surface was very striking.

An interesting finding relates to the volume of fixative that could flow into the lungs from the burettes. In groups CB, B1, and B2 this amounted to 6 ml on the average. In B3 it was reduced to 5 ml, and in B4 even to 2.6 ml. This may partially have been due to the presence of pleural exudate, but partially also to pulmonary edema as described below.

In groups B3 and B4 the livers and spleens showed increasing signs of congestion, indicating right heart failure.

Light microscopic findings

In figures 2 and 3 a low power micrograph of a section of a normal control lung CB is confronted with a corresponding section from a B4 lung (72 hours in 98.5% oxygen). In the normal lung the very fine regular pattern of airspaces is easily recognized. In figure 3 this pattern appears preserved in a few areas but is obliterated in other regions. This is due to an accumulation of exudate in alveoli and

air ducts, as can be seen more clearly in figures 4 and 5, which also show the patchy distribution of exudate. A certain portion of the lung appears more or less normal at this level of resolution. A quantitative appraisal of the relation between "normal" and pathological alveoli will be reported below.

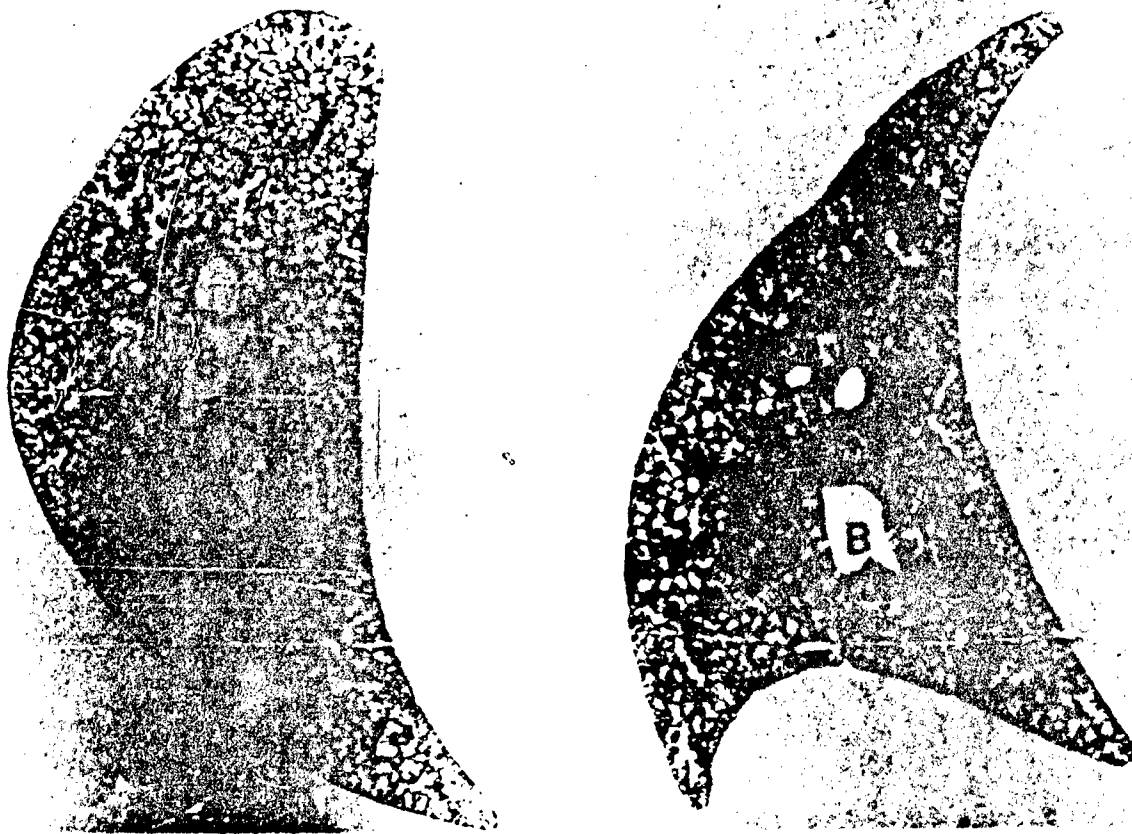

Figure 2. CONTROL LUNG CB. B = bronchus. Goldner stain. x 11.

Figure 3. B4 LUNG. Observe patchy accumulation of exudate in airways, as well as perivascular edema. B = bronchus. Goldner stain. x 11.

The alveolar exudate appears to consist of three components: most of the affected alveoli are filled with a structureless fluid assuming a green color in Goldner's trichrome stain, which indicates its protein content (figure 5). Within this exudate an extraordinarily high number of alveolar macrophages is found (figures 5 and 6), while in other regions masses of fibrillar material are found (figure 7) which consists of fibrin, as will be shown below.

The interalveolar septa of B4 lungs appear thickened with an increased number of constituent cells, while the blood capillaries seem somewhat less conspicuous than in normal lungs. In contrast to these striking findings in the terminal test group B4, the lungs of the rats of groups B1, B2, and B3 showed not much of a pathological appearance. In the groups B1 and B2, no alveolar exudate was observed. There was some indication of an irregularity in the filling of capillaries with blood; however, it could not be excluded that this subjective interpretation could be related to a variation in section thickness. In the B3 lungs there appeared an indication of beginning formation of alveolar exudate as seen in the terminal group. The number of alveolar macrophages was somewhat increased.

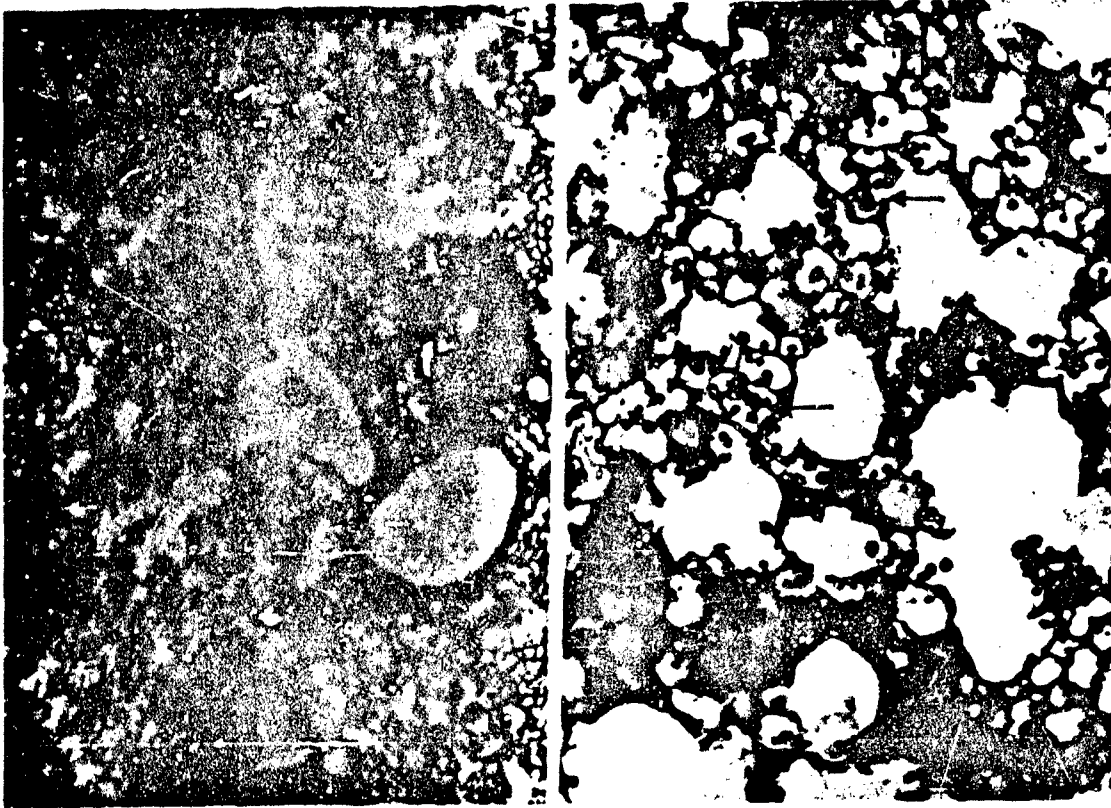

Figure 4. B4 LUNG. Patchy accumulation of exudate. Perivascular edema (e) near bronchus B. Goldner stain. x 40.

Figure 5. B4 LUNG. Exudate and numerous macrophages (arrows) in alveoli. Goldner stain. x 300.

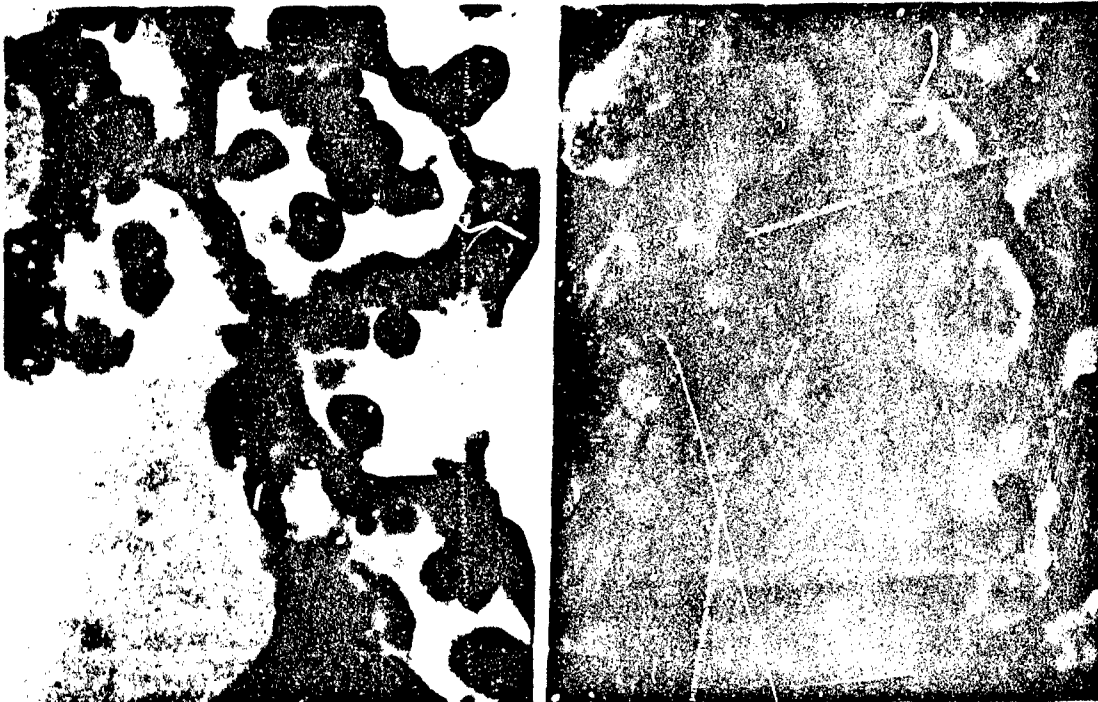

Figure 6. B4 LUNG. Alveolar macrophages. Interalveolar septa thickened. Goldner stain. x 750.

Figure 7. B4 LUNG. Fibrin threads in alveoli with exudate. Interalveolar septa thickened. Goldner stain. x 750.

Figures 3 and 4 show that the normally narrow connective tissue space enveloping the larger blood vessels is strikingly edematous in the B4 lungs. This perivascular edema can also be observed in the B3 lungs, but not in the earlier stages.

It has become clear from the preceding description that only a limited amount of substantial information can be drawn from standard histological preparations. Their main defect is the section thickness which is of the same order of magnitude as the interalveolar septa and the capillaries. We have therefore extended these studies by observing thinner sections ($0.5 - 1 \mu$) in a phase contrast microscope. As illustrated by figures 8 - 11, this method brings a considerable gain in resolution, and still allows surveys of larger fields. It thus forms an excellent intermediary to electron microscopy.

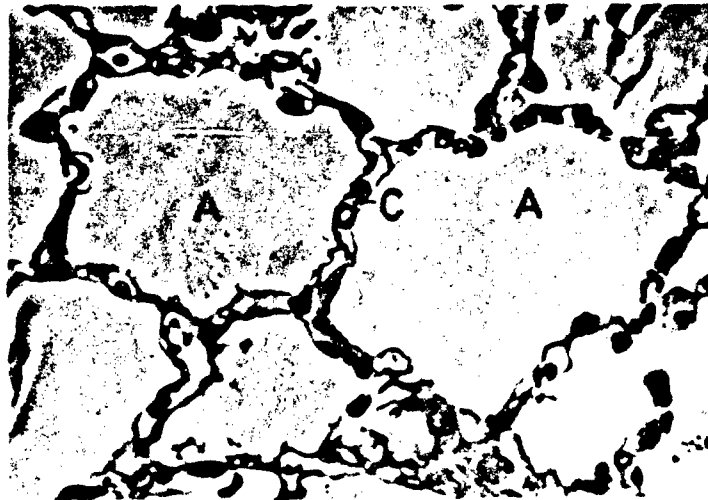

Figure 8. CONTROL LUNG CB. Phase contrast micrograph of thin section. Note red cells in capillaries and delicate air-

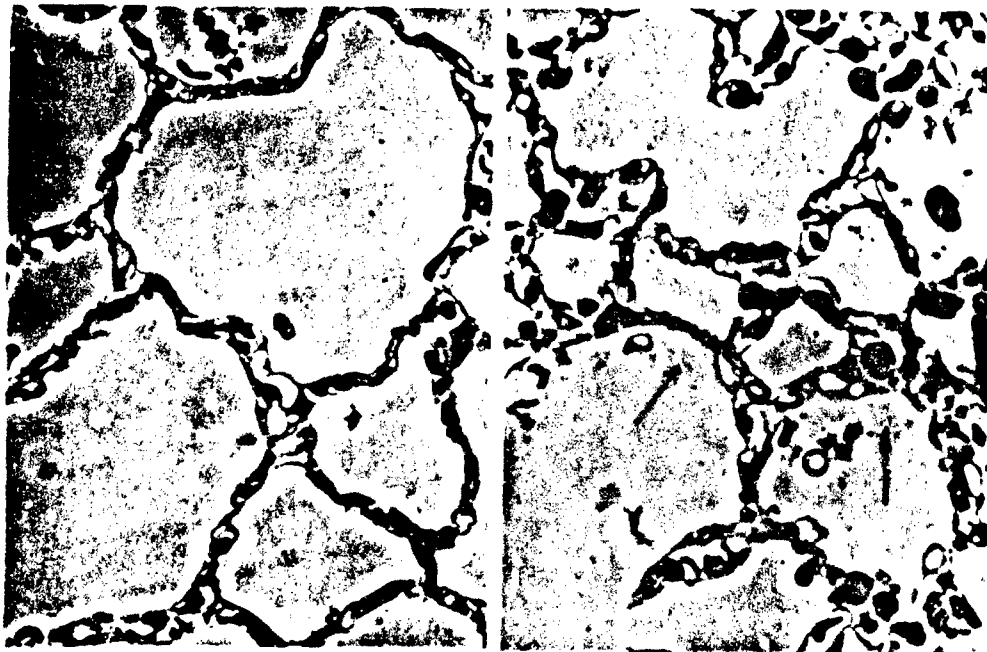

Figure 9. B3 LUNG. Phase contrast micrograph of thin section. Relatively normal portion. x 600.
Figure 10. B3 LUNG. Phase contrast micrograph of thin section. Thickening of interalveolar septa and beginning formation of alveolar exudate (arrows).

In the normal lung the alveolo-capillary membrane separating air and blood be clearly distinguished (figure 8). Figure 9 shows that similar areas with normal appearance occur in B3 lungs. In other regions of these lungs (figure 10) alveolo-capillary tissue layer appears thickened and some exudate has formed the alveolar wall. Figure 11 shows a region of a B4 lung in which the alveolo-capillary membrane is severely thickened; the number of cells is increased. The alveolar membrane thickened with respect to figures 3 - 7 is also seen. Corresponding sections of lungs of the B1 and B2 group revealed no pathological findings.

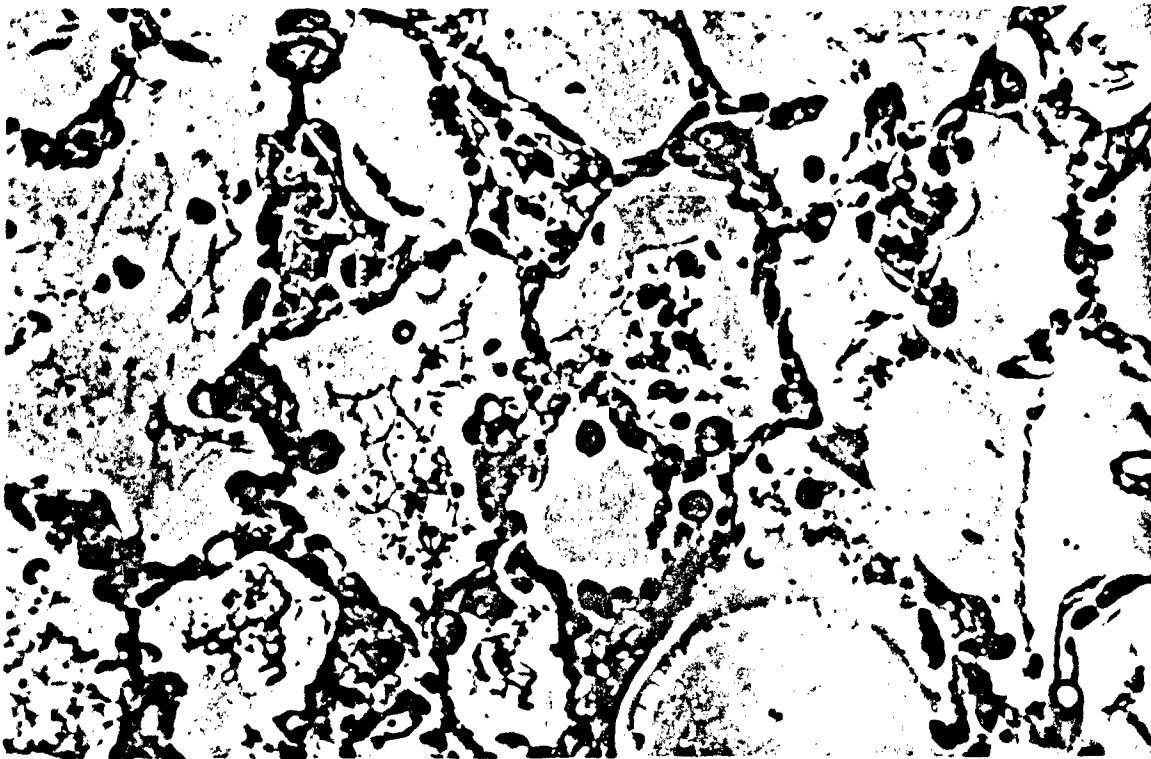

Figure 11. B4 LUNG.

Phase contrast micrograph of thin section. Severe thickening of interalveolar septa with increased number of cells and obliteration of capillaries. Alveoli filled with exudate containing red cells, cell debris and fibrin threads.

Electron microscopic findings

Figure 12 illustrates the relevant features of the fine structure of the normal lung (CB) at the alveolo-capillary level. The capillaries are lined by a thin endothelial cell layer; the alveoli are lined by an epithelial layer which, for the most part, is equally thin. Some large cells containing the characteristic "lamellated bodies" are incorporated into this epithelium (figure 12b). It is particularly important to note that the interstitium which separates endothelium and epithelium is mostly very narrow. In some regions between capillaries the interstitium is wider and contains fibroblasts, collagenous and elastic connective tissue fibers

(figures 12a and b). It should be emphasized, however, that the fluid ground substance between these formed elements occupies only an extremely narrow space, as seen in figure 12b.

In figure 13 two corresponding fields from a section of a B3 lung are reproduced. The striking enlargement of the interstitial space is quite evident. It is due to an accumulation of fluid in the ground substance space, which caused a wide separation of the formed interstitial elements, as well as of endothelium and epithelium. An extreme instance of this interstitial edema is shown in figure 14; the nature of the very fine dark granules in the edematous fluid is not clear. In more severely damaged regions of B3 lungs we observe an infiltration of the tissue with leucocytes and a beginning destruction of endothelial cells (figure 15). Though such areas are relatively scarce they are indicative of the third day of exposure to pure oxygen.

Key to symbols on electron micrographs

A	Alveolus	EP	Alveolar epithelial cell
ACB	Alveolo-capillary barrier	FB	Fibroblast
BM	Basement membrane	FN	Fibrin
C	Capillary	LB	Lamellated body
CF	Collagen fibrils	LC	Leucocyte
EC	Erythrocyte	M	Mitochondrion
ED	Interstitial edema	MF	Myelin figure
EL	Elastic fibers	N	Nucleus
EN	Capillary endothelial cell	T	Thrombocyte

Figures 16 - 21 illustrate the damage established at 72 hours in the B4 group. Comparing the low power electron micrograph of figure 16 with figures 12a and 13a it can be realized how far away from normal the situation at the alveolo-capillary level is. Capillaries are hardly recognized, except for their content of highly distorted and partially fragmented erythrocytes. Figure 17 illustrates the destruction of endothelial cells characteristic of this stage. Often, red cells are seen to be in immediate contact with the endothelial basement membrane (figure 18), indicating the complete disappearance of the endothelial lining in such regions. In the interstitium the striking edema observed in the B3 lungs has disappeared. It is replaced by numerous interstitial cells, partly identifiable as leucocytes and lymphocytes, by fragments of (destroyed) cells, and by thrombocytes and fibrin strands. Figure 19 illustrates such a region, the fibrin nature of the dark staining strands being demonstrated by the characteristic periodicity observed at high power in the insert. It is interesting to note that the alveolar epithelium is usually found to be intact in these cases, even where the alveolus is filled with exudate.

Figures 20 and 21 finally illustrate the three types of formed elements found in alveolar exudate in B4 lungs. The fibrin strands have been mentioned in relation to figures 7 and 11. Figure 21 shows sections of such strands at high power, proving their fibrin nature by the characteristic periodicity observed in the longitudinal sections. In addition, we found numerous spherical elements of varying size composed of concentric lamellae (figures 20 and 21). It is probable that these "myelin figures" consist of lipids. Another peculiar formed element of alveolar exudate

was commonly observed: it consisted of "whorls" of subunits which were grouped in parallel and were clearly delineated by fine dark lines. Between these "lines" a pair of lighter lines was observed. The exact structure of this interesting material needs to be further investigated; its nature is unknown as yet.



Figure 12. ELECTRON MICROGRAPHS OF CONTROL LUNG CB.
 (a) low power view of interalveolar septum. Note delicate alveolo-capillary barrier and narrow interstitial space. x 6,300.
 (b) Fibroblast and connective tissue fibers in narrow interstitial space between capillaries. Epithelial cell with lamellated bodies. x 10,500.



Figure 13. ELECTRON MICROGRAPHS OF B3 LUNG. Compare with figure 12.
 (a) low power view of interalveolar septum. Widened interstitial space with edema and increased number of interstitial cells. x 4,700.
 (b) Widening of interstitial space by edema. Note separation of capillaries and fibers. x 10,500.

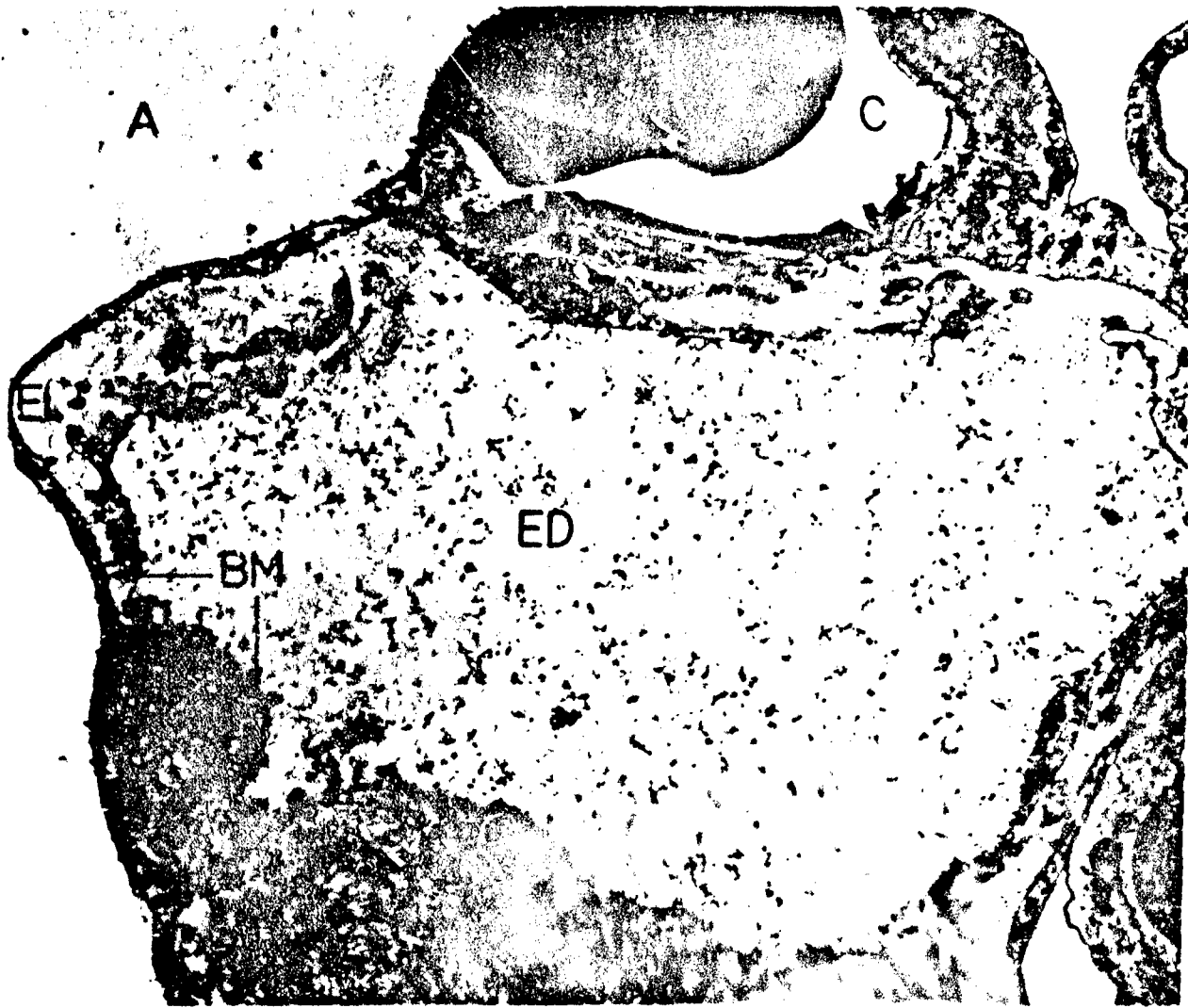

Figure 14. ELECTRON MICROGRAPH OF B3 LUNG.
Massive accumulation of edema fluid in interstitial
space. x 10,500.

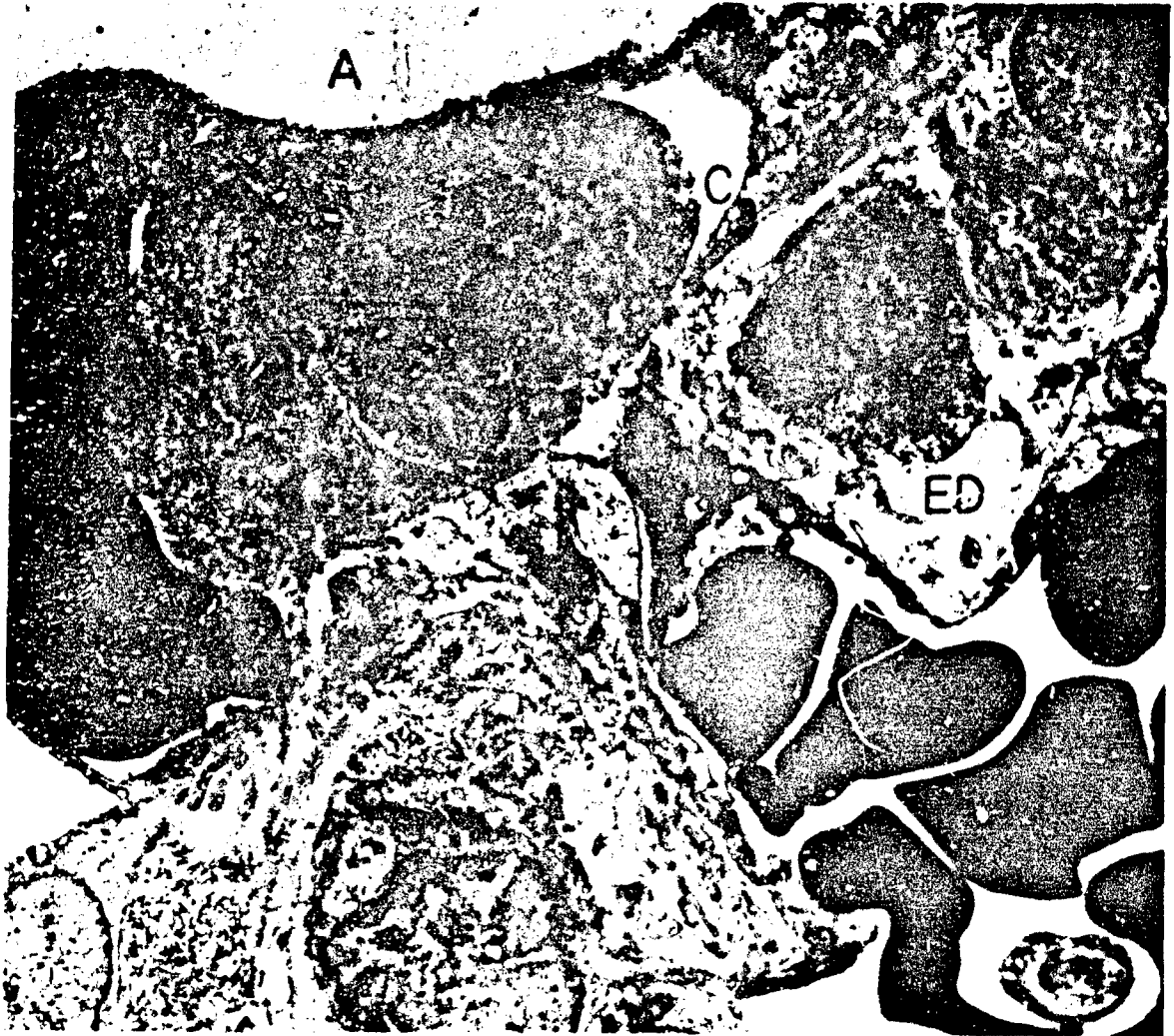

Figure 15. ELECTRON MICROGRAPH OF B3 LUNG.
Heavily damaged region. Intravascular and interstitial leucocytes with phagocytosed material. Partial destruction of capillary endothelium (EN'). Interstitial fibrin formation. x 7,700.

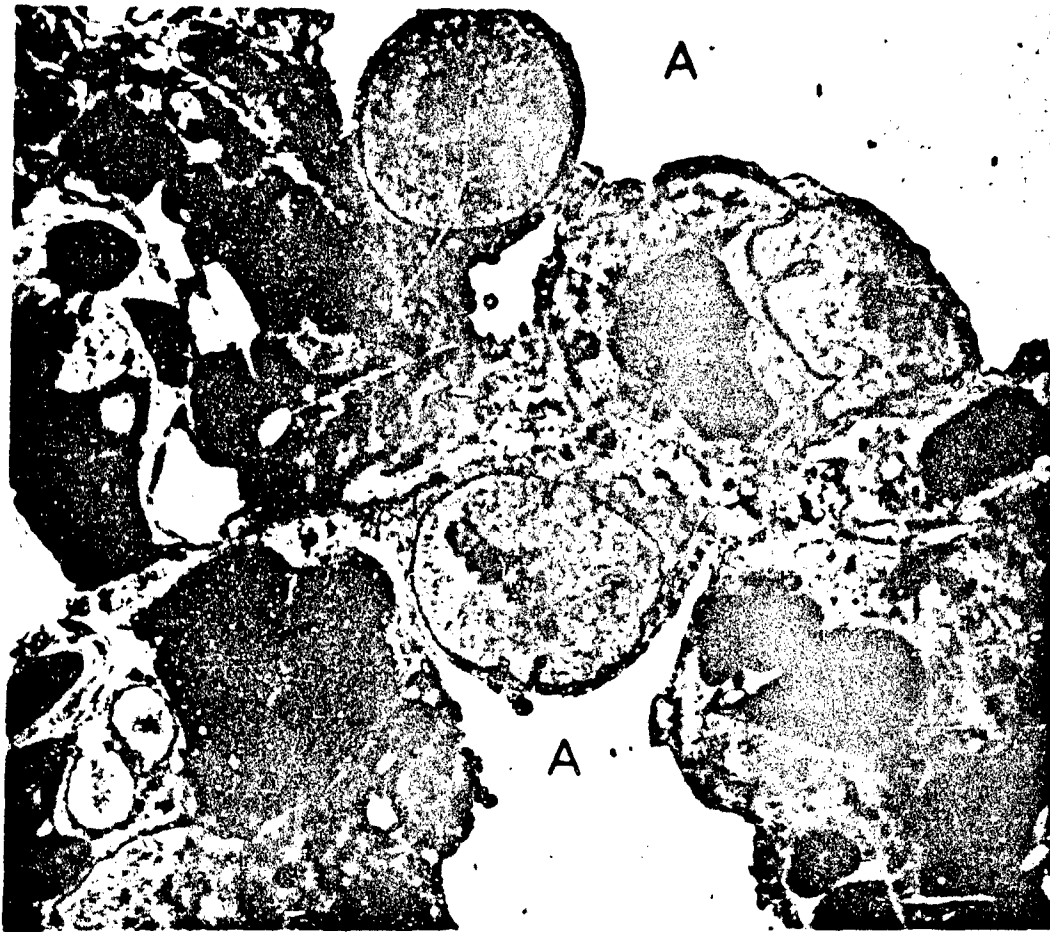

Figure 16. LOW POWER ELECTRON MICROGRAPH OF INTERALVEOLAR SEPTUM OF B4 LUNG. Compare with figures 12(a) and 13(a). The massive changes are obvious: partial destruction of capillaries; fragmentation of erythrocytes (EC'); accumulation of thrombocytes; formation of interstitial fibrin threads. Epithelial covering seemingly intact. x 4,700.

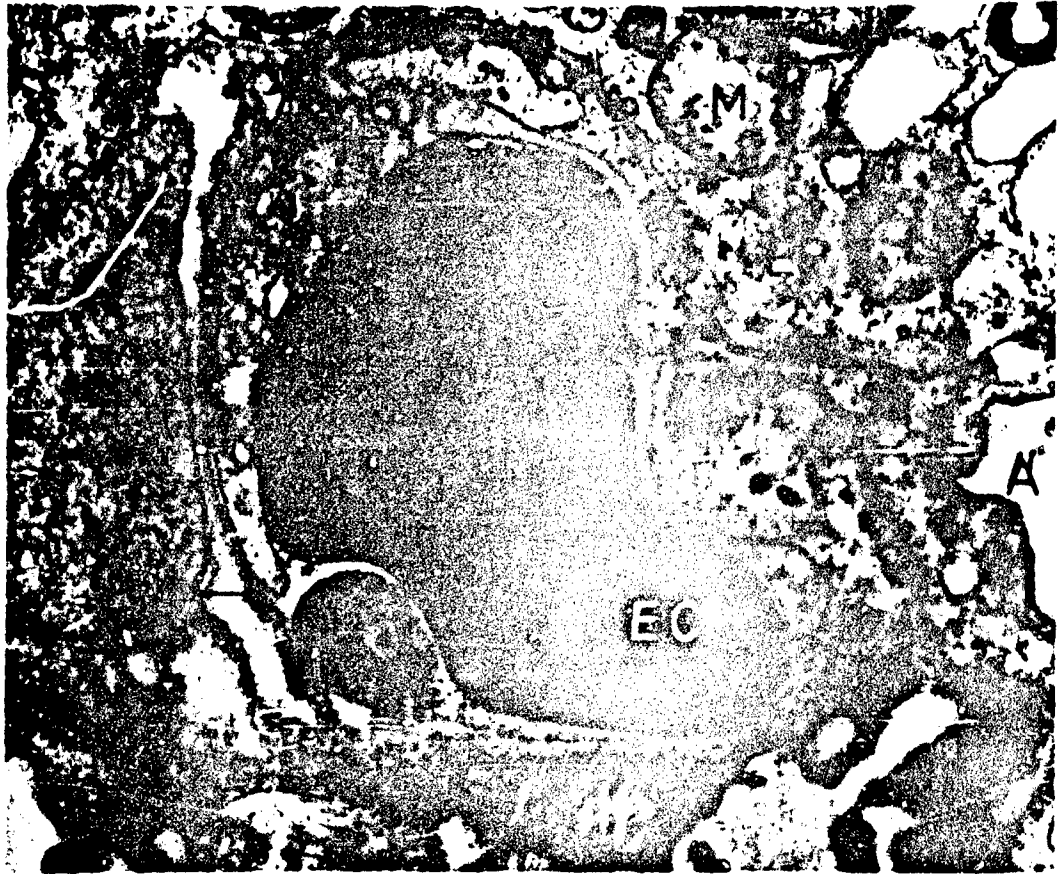

Figure 17. ALVEOLAR CAPILLARY OF B4 LUNG IN PHASE OF DESTRUCTION. Endothelial lining disintegrates (EN'). Basement membrane appears intact. x 23,200.

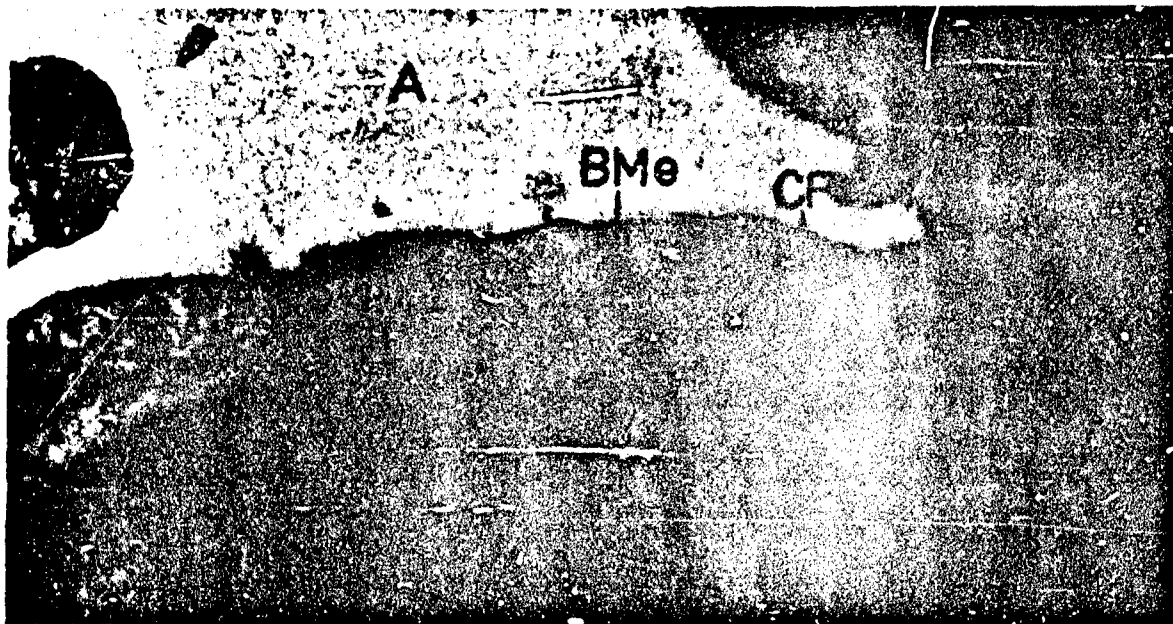

Figure 18. ALVEOLO-CAPILLARY BARRIER OF B4 LUNG. Endothelial lining is missing; erythrocyte cell membrane (arrows) touches basement membrane of former endothelium (BMe). Note difference in darkness of erythrocytes, indicating different hemoglobin density. x 24,200.

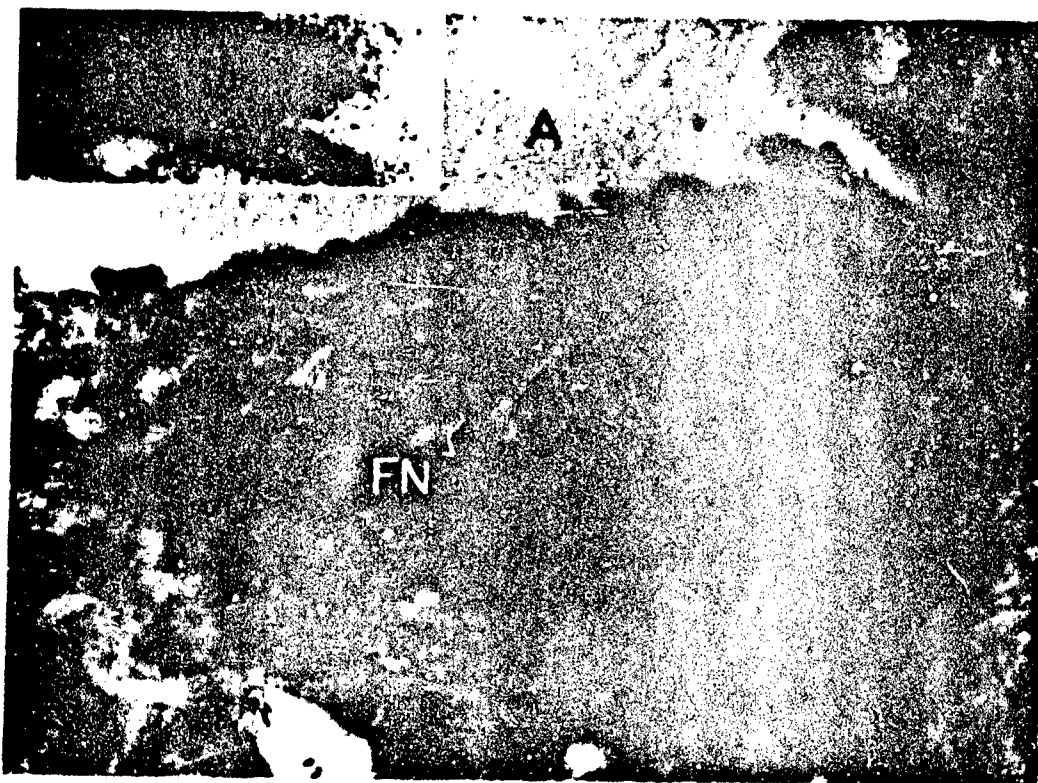

Figure 19. INTERSTITIAL FORMATION OF FIBRIN IN B4 LUNG. Insert demonstrates typical periodicity of fibrin filaments. x 17,500 (insert x 57,000).



Figure 20. STRUCTURE OF FORMED COMPONENTS OF ALVEOLAR EXUDATE IN B4 LUNG. Numerous "myelin figures" (i. e. concentric arrangement of strongly osmiophilic lamellae), and layered material of unidentified nature. x 24,200.

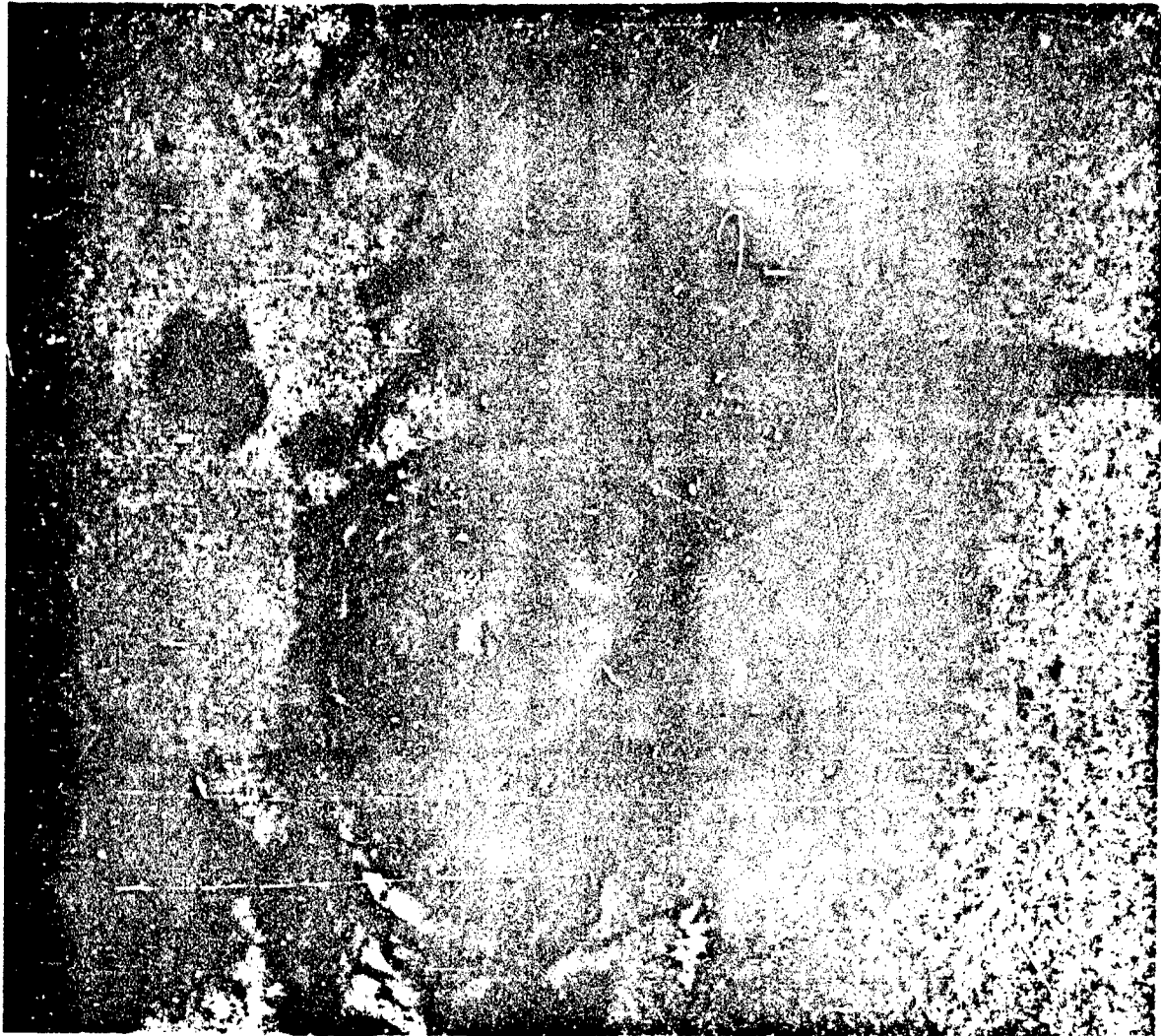

Figure 21. HIGHER MAGNIFICATION OF A "MYELIN FIGURE" FROM ALVEOLAR EXUDATE IN B4 LUNG. Longitudinal sections of thread-like material shows periodicity characteristic of fibrin. x 42,800.

MORPHOMETRIC STUDIES

Overall lung volume

As baseline values for the quantitative studies, the volumes of the inflated lungs were measured by fluid displacement after fixation in glutaraldehyde. The mean volumes of those lungs used in this study are given in table II. In all calculations of overall parameters presented below, however, the individual lung volumes were used.

TABLE II
AVERAGE VOLUMES (V_L) OF FIXED LUNGS IN ML AND
LUNG VOLUME-TO-BODY WEIGHT RATIOS (V_L/BW)
OF RATS USED FOR QUANTITATIVE STUDY

<u>Group</u>	<u>V_L (mean)</u>	<u>V_L/BW</u>
CB	5.62 + 0.60	0.045
B1	5.22 + 0.74	0.045
B2	6.38 + 0.41	0.054
B3	6.62 + 0.37	0.054
B4	4.42 + 0.33	0.043

+ values = S. D.

Morphometric survey of histologic sections in the light microscope

As discussed above, the light microscope allowed only a coarse evaluation of the damage to alveoli, while changes in capillary bed and tissue could not be reliably assessed because of the interfering section thickness. We have therefore restricted ourselves to a determination of the volume fraction of the lung occluded by alveolar exudate in the lungs of the B4 group as compared to the control group. The results are given in table III and in figure 22. It can be seen that, after 72 hours of exposure to oxygen, two-thirds of the alveolar space is obliterated by exudate, almost half of which contains fibrin. This means that only one-third of the alveoli is, at best, available for gas exchange. These data have not been corrected for the effect of section thickness which leads to a systematic overestimation of the "dark" parts of the sections, i. e. the septa, by a factor of 2 to 3, with a corresponding underestimation of the alveolar space. For purposes of comparison this correction is not necessary. An extension of this survey to earlier stages appeared useless, because of the limited resolution attainable by this method.

TABLE III

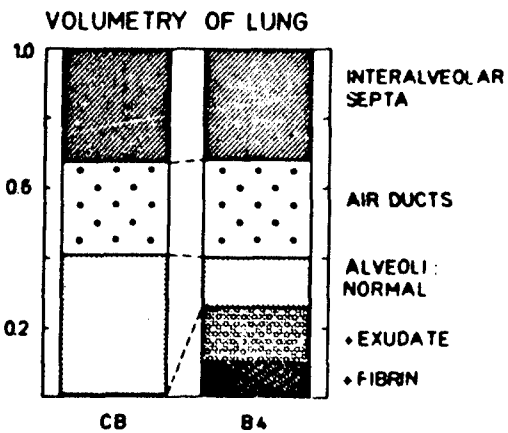

Components	CB	B4
Septa	.33*	.31*
+ S. E.	.006	.014
Ductuli	.26*	.28*
+ S. E.	.016	.026
Alveoli	.41*	.41*
+ S. E.	.010	.027
normal Alveoli	1.0	.35
obliterated Alv.	-	.65
+ S. E.	-	.005
(Alv. containing Fibrin)	-	(.26)
+ S. E.	-	(.005)

Figure 22. COMPARISON OF COMPOSITION OF LUNG IN CONTROL AND B4 ANIMALS, OBTAINED FROM LIGHT MICROSCOPY. Data not corrected for effect of section thickness!

*not corrected for section thickness effect!

Morphometric studies in the electron microscope

The high resolution attainable by electron microscopy made it possible to investigate a considerable number of parameters. These can be classed into volume ratios, absolute volumes, surface areas, volume-to-surface ratios, thicknesses, and numbers of structures. The data resulting from this study are summarized in Table IV and in figures 23 and 24. The results of the statistical tests are summarized in figure 24.

In figure 23 the overall subdivision of the lung parenchyma into air spaces (normal and pathologic pooled), blood in capillaries, and tissue is histographically presented for each animal investigated. It illustrates the consistency of the data obtained on these minute random samples of tissue (see below).

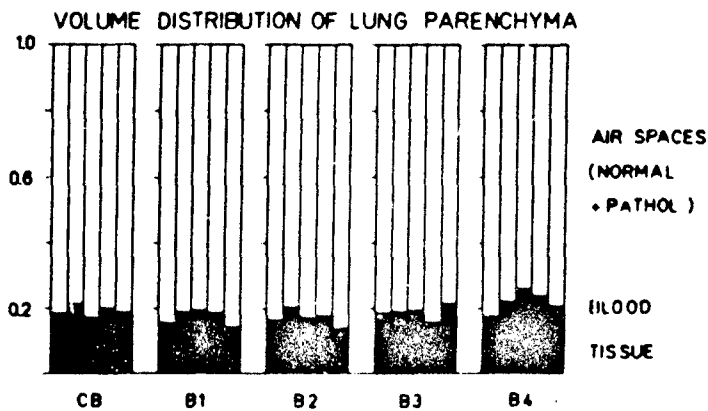

Figure 23. COMPARISON OF COMPOSITION OF LUNG OBTAINED FROM ELECTRON MICROSCOPY.

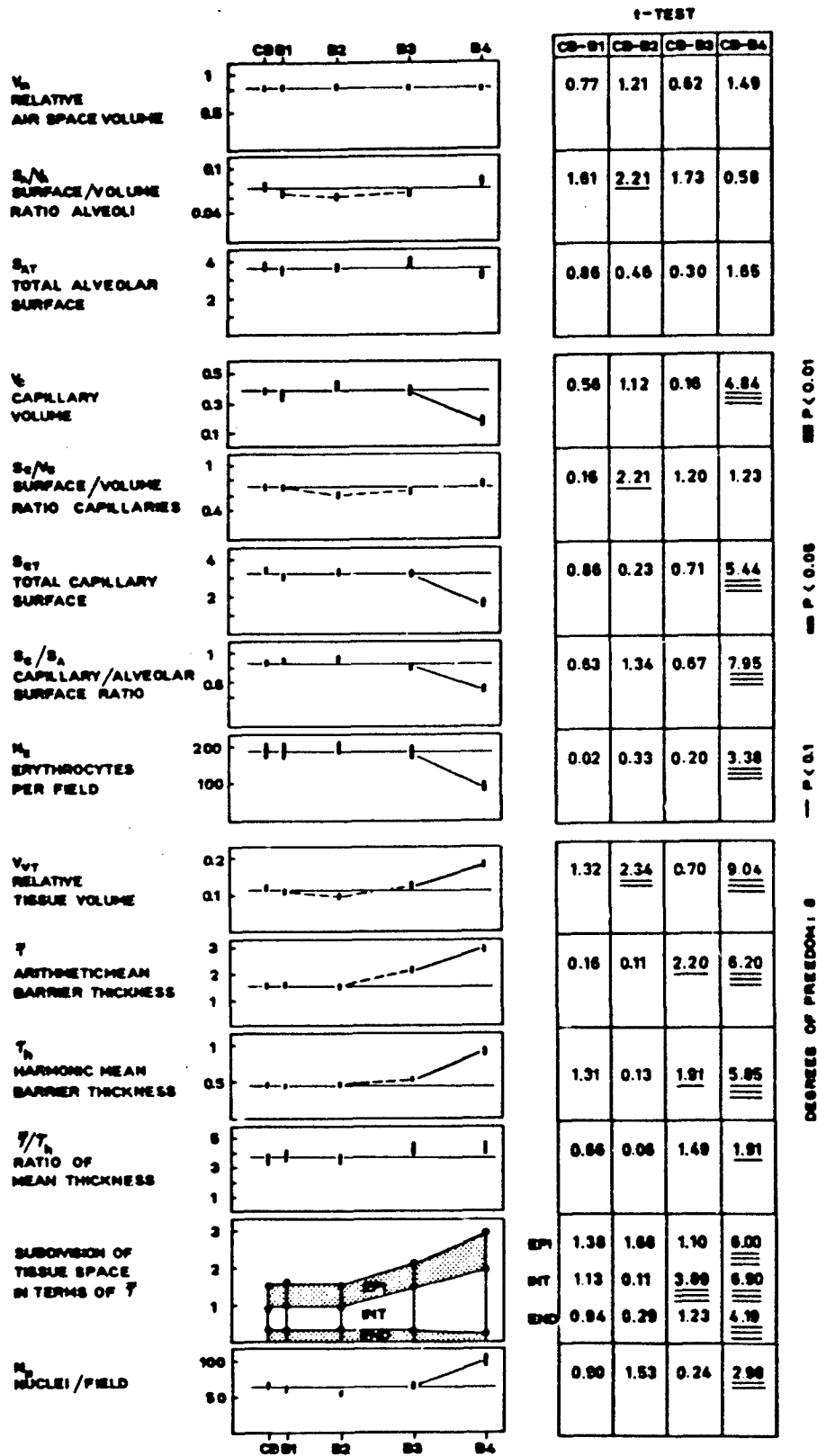

Figure 24. SYNOPSIS OF RESULTS OF MORPHOMETRIC STUDY.

TABLE IV

SYNOPSIS OF RESULTS

GROUP	VVA	S _V /V _A	S _{AT}	V _C	S _C /V _C	S _{CT}	S _C /S _A	E	V _{VT}	$\bar{\tau}$	τ_h	$\bar{\tau}/\tau_h$	$\bar{\tau}_{EPI}$	$\bar{\tau}_{INT}$	$\bar{\tau}_{END}$	η_N
	μ^{-1}	10^3	ml	μ^{-1}	10^3	10^3				μ	μ		μ	μ	μ	
	cm ²	cm ²			cm ²	cm ²										
CB	.81	.077	3.82	.38	.70	3.40	.85	186	.117	1.51	.45	3.5	.67	.55	.29	66
\pm SE	.010	.005	.32	.039	.037	.26	.002	27.0	.006	.11	.017	.29	.032	.036	.017	4.4
B1	.82	.067	3.42	.35	.69	3.04	.88	186	.104	1.55	.42	3.8	.58	.71	.27	60
\pm SE	.013	.004	.29	.049	.053	.33	.044	24	.008	.16	.006	.40	.007	.138	.014	5.8
B2	.83	.060	3.64	.44	.59	3.33	.90	197	.094	1.50	.44	3.5	.60	.54	.28	54
\pm SE	.012	.006	.21	.039	.037	.195	.035	21	.008	.16	.017	.16	.030	.027	.017	6.5
B3	.81	.064	3.95	.39	.64	3.16	.81	179	.125	2.05	.51	4.2	.62	1.18	.25	64
\pm SE	.012	.006	.31	.033	.035	.210	.053	21	.010	.27	.025	.43	.039	.159	.026	7.0
B4	.78	.082	3.20	.17	.76	1.68	.52	92	.179	2.88	.90	4.3	.99	1.71	.18	102
\pm SE	.018	.007	.20	.019	.035	.18	.036	7	.003	.26	.075	.39	.061	.165	.020	11.2

Air spaces

In the normal lungs, and in those of the experimental groups B1 - B3 the air spaces occupied about 80% of the lung volume (V_{VA} table IV), the standard error being of the order of 1%. In the B4 group the air space volume showed a tendency to drop; however the difference to the control values was not significant in the t-test (figure 24).

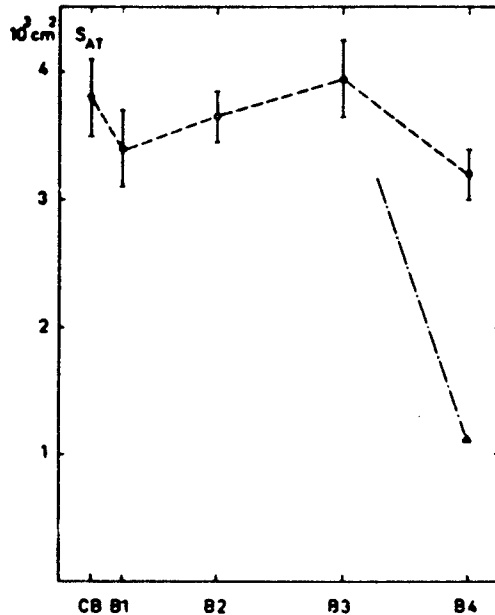

Figure 25. SURFACE AREA OF ALVEOLAR EPITHELIUM (Triangle indicates alveolar surface area available for gas exchange in B4 lungs.)

The surface area of the alveolar epithelium S_{AT} showed much the same behavior (figure 25). It measured about 0.35 m^2 . The small reduction in the B4 group was not significant. The alveolar surface-to-volume ratio (S_A/V_A) remained unchanged throughout, except for an unexplained slight drop in B2 (figure 24). From these data it can be concluded that the architectural framework of the lung remained unchanged despite the drastic formation of alveolar exudate.

Alveolar capillaries

The capillary bed occupied 7 - 8% of the total lung volume in groups CB, B1, B2, and B3 which amounted to an absolute volume (V_C) of approximately 0.4 ml on the average, the standard error being of the order of 10% (figure 26). In B4 V_C dropped to less than half, the difference being highly significant ($P < 0.01$). A concurrent observation related to the number of erythrocyte sections counted per field of observation (figure 27); the drop in B4 was again highly significant.

The total capillary surface area S_{CT} also fell from about 0.3 m^2 in groups CB to B3 to about half in B4 (figure 28). But again the surface-to-volume ratio S_C/V_C remained constant (figure 24), indicating that the reduction of V_C and S_{CT} was due to a loss in the number of patent capillaries without much change in the general architecture of the remaining capillaries. The drop of this ratio in B2, which is slightly significant, cannot be explained and has to be further evaluated.

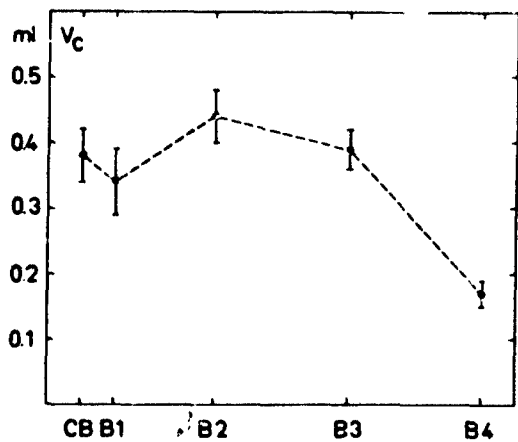

Figure 26. CAPILLARY VOLUME

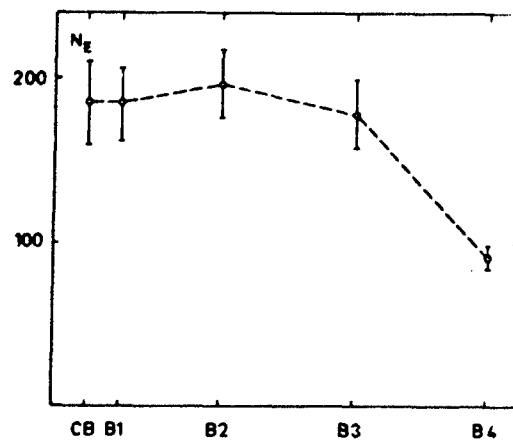

Figure 27. ERYTHROCYTES PER FIELD

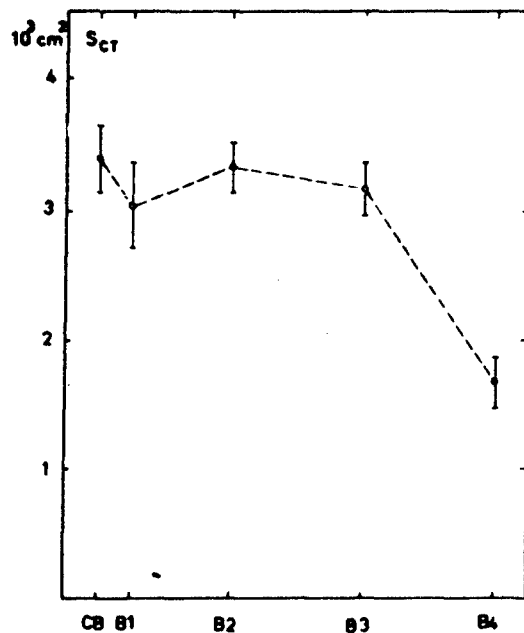

Figure 28. SURFACE OF CAPILLARY ENDOTHELIUM

Alveolo-capillary tissue

About 12% of the total volume of control lungs is occupied by tissue (figure 24 and table IV). We observed a small decrease of this relative tissue volume V_{VT} in B2 ($P < 0.05$). In B3 V_{VT} is back to 12.5% and climbs to 18% in B4. The average thickness of the alveolo-capillary tissue barrier \bar{r} was estimated at 1.5μ with a standard error of 0.15μ (figure 29). It remained constant from CB to B2. The rise of \bar{r} to 2.05μ observed in B3 was statistically significant at the level $P < 0.1$. The further thickening of the barrier to $\bar{r} = 2.9 \mu$ in B4 was however statistically highly significant ($P < 0.01$). We can therefore conclude that the tissue mass of the barrier becomes almost doubled after 72 hours in oxygen.

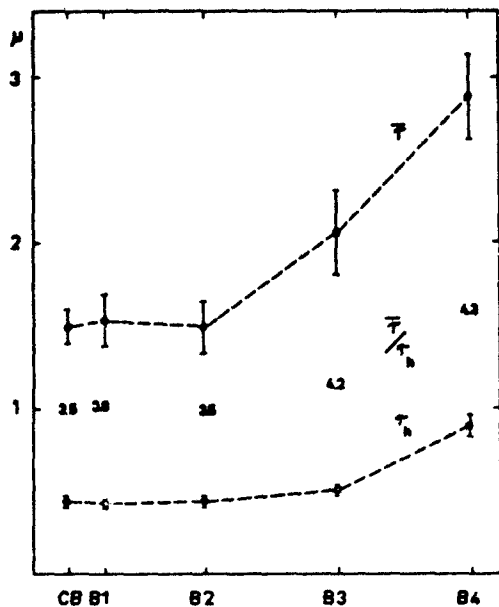

Figure 29. PLOT OF ARITHMETIC MEAN ($\bar{\tau}$) AND HARMONIC MEAN ($\bar{\tau}_h$) OF BARRIER THICKNESS

The effective thickness with respect to diffusion of gases between air and blood is however measured by the harmonic mean thickness τ_h estimated at 0.45μ in the control lungs (figure 29). τ_h remained unchanged in B1 and B2, showed a slight increase to 0.51μ in B3 ($P > 0.1$), and a highly significant doubling to 0.9μ in B4 ($P > 0.01$).

It is thus interesting to note that arithmetic and harmonic mean thicknesses increased in parallel; there was only a slightly significant variation in the ratio of these two means $\bar{\tau}/\bar{\tau}_h$ (figures 24 and 29). This ratio estimates the relative frequency of "thin" and "thick" regions of the barrier, in other words, it is a measure of its geometric configuration as a "rippled" membrane.

We were, then, interested to see how the different components of the tissue space were affected by the damage due to oxygen exposure, and have therefore calculated the mean thickness of alveolar epithelium, interstitium and capillary endothelium. The data obtained are listed in table IV and plotted in figure 30. We note no changes in groups B1 and B2 with respect to the controls. At 48 hours (B3) the thickness of the interstitium is doubled ($P > 0.01$), while epithelium and endothelium preserve their original thickness. In the terminal B4 group the epithelium becomes thicker by 50%, the interstitium shows a further increase to the triple of the control value, while the average thickness of the endothelium drops to 60%. All these changes are significant at the $P > 0.01$ level.

The average number n_N of sections through cell nuclei counted per field of observation (figure 31), showed a significant increase only in the B4 group. This could be related to two observed changes: the accumulation of leucocytes in the interstitium and the increase in the number of free alveolar cells (macrophages).

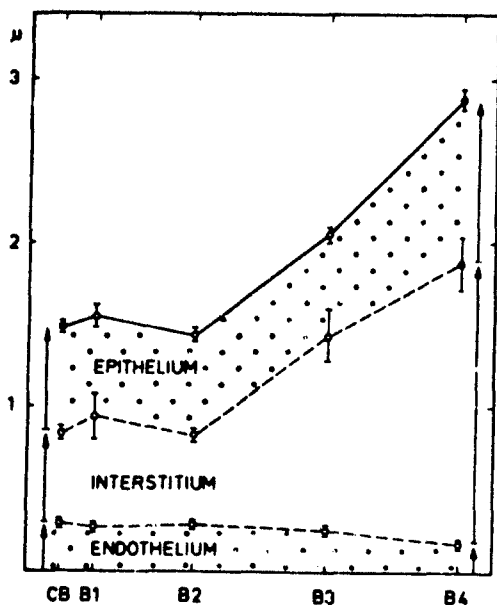

Figure 30. DISTRIBUTION OF BARRIER THICKNESS AMONG COMPONENTS

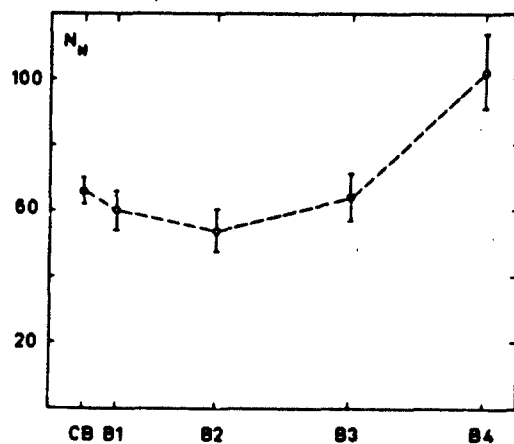

Figure 31. NUCLEI PER FIELD

DISCUSSION

The phenomenological description of the pulmonary pathology observed in our experiments after prolonged exposure of rats to pure oxygen at atmospheric pressure in general confirms the findings of previous investigators, at least as far as conventional light microscopy is concerned. With respect to the ultrastructure of the damages, our findings differ in some points from those of Cedergren et al (ref 14). We could not find any "edematous swelling" of alveolar epithelial and capillary endothelial cells, as described by these investigators. The alveolar epithelium remained astoundingly unchanged and exhibited, on quantitative analysis, a slight thickening only on the terminal phase. From the appearance of the epithelial cells we would tend to typify this thickening rather as proliferation than as cytoplasmic swelling. The cytoplasmic changes accompanying the disintegration of the capillary endothelial lining were in many respects also different from simple "cytoplasmic edema". In the development of extensive interstitial edema during the second day (B3, figures 13-14) the fluid accumulated clearly within the interstitial ground substance space. The basement membranes remained closely apposed to endothelial and epithelial cells. Some of these differences may be due to the different methods of preparation used here as compared to the earlier work of Cedergren et al. In the other points our observations agree, particularly with respect to the occurrence of mitochondrial swelling in alveolar epithelial cells, which we also found to be not too frequent, and only appearing in the terminal stages. This in contrast to Schulz (ref 22) who described this phenomenon as a characteristic cellular lesion of oxygen toxicity. This point will be further investigated.

This study pursued two chief aims: a definition of the time sequence of events, and a quantitative definition of the degree and extent of damage, with the goal of possibly defining the degree of impairment of lung function.

TIME SEQUENCE OF EVENTS

The first detectable damage of the lung occurs during the second day of exposure to oxygen, beginning with interstitial edema, probably due to a gradual development of defects in the capillary endothelial lining. The tissue space also becomes infiltrated by leucocytes and thrombocytes; fibrin forms interstitially. During the third day this damage becomes precipitously aggravated, with an appreciable destruction of capillaries accompanied by destruction of numerous erythrocytes. During this third day a profuse exudation must take place into a large fraction of alveoli. They become completely filled with a fluid containing numerous macrophages, erythrocytes, leucocytes, cell debris, fibrin strands, lipids and some unidentified organized material which possibly is a protein-lipid-compound. This appears as the terminal stage, reached for rats after 72 hours in oxygen, at which survival in room air is no longer possible; even in a high oxygen atmosphere the animals rapidly die.

It thus appears that the basic toxic effect of oxygen must be initiated rather early, that is towards the end of the first day of exposure, since all the observed effects must be secondary to some still unknown disturbance at the subcellular - or even molecular - level.

QUANTITATIVE DEFINITION OF DAMAGE

Hitherto, no attempt at quantitative evaluation of pulmonary pathology due to oxygen poisoning has been attempted, although some quantitative statements have been expressed on the basis of mere subjective observation. The application of established morphometric techniques (ref 23, 24, 29 - 34) has allowed an objective quantitative appreciation of the damages, which could be statistically evaluated. This can be summarized as follows (compare figure 24):

a. Air spaces

The architectural framework of the air spaces remains unchanged. However, during the third day up to 65% of the alveoli become obliterated by exudate and are thus eliminated as gas exchange units. Only 35% of the measured surface of the alveolar epithelium remains available for gas exchange (figure 25).

b. Capillaries

Volume and surface of the alveolar capillaries remain constant for the first two days, but become significantly reduced during the third day. At no point is there an increase of either capillary volume or surface (or of the capillary endothelial volume) which could indicate a general enlargement of capillaries (ref 1), or even a capillary proliferation as suggested by Pratt (ref 21) for humans. During the second and third day there is even a gradual but extensive destruction of capillaries, correlating to the drop in V_C .

The slightly significant reduction in the ratio S_C/V_C after one day in oxygen (figure 24) may be related to the observation of irregular size of the capillaries. With a widening of the distribution of capillary diameters the total capillary surface would tend to fall if the overall volume remained constant. Some scattered dilated capillaries might also appear as congestion or even proliferation, mainly in thick histologic preparations.

c. Alveolo-capillary barrier

The average thickness $\bar{\tau}$ of the alveolo-capillary barrier, which includes alveolar epithelium, interstitium, and capillary endothelium, measures the mass of tissue separating air and blood. Functionally however, the harmonic mean thickness τ_h is the overall measure of resistance to gas exchange (ref 29). Both these dimensions show a concurrent slight increase during the second day which is most severely aggravated during the third day. $\bar{\tau}$ rises from normally 1.5μ to 3μ after 72 hours; τ_h from 0.45μ in the controls to 0.9μ in the terminal stage. This increase in thickening is restricted to a widening of the interstitial space during the second day. During the third day the epithelium also becomes significantly thickened; the interstitium enlarges still more, while the endothelium is reduced by regional destruction.

EFFECT OF THESE CHANGES ON LUNG FUNCTION

Studies in men breathing oxygen under the same conditions as those of the present study showed a drop in diffusing capacity to 81% of the control value after 48 hours and to 73% after 74 hours of exposure. The total lung capacity fell to 72% of the control value after 74 hours (ref 7). These results might readily be explained on the basis of thickening of the air-blood tissue barrier, a decrease in pulmonary capillary surface area and alveolar edema formation seen in the present study.

Since, in the experiments reported here, principal structural elements related to the diffusing capacity of the air-blood barrier could be measured, it was possible to make an estimate of its capacity for gas exchange from the proportionality relationship:

$$D_m = \frac{S_{CT}}{h}$$

where, D_m is the gas exchange capacity of the air-blood tissue barrier, S_{CT} is the capillary surface area, and τ_h is the harmonic mean thickness of the air-blood tissue barrier.

The results, expressed as percent of control value, indicate a fall of the air-blood barrier diffusing capacity to 25% after 72 hours of oxygen exposure (table V and figure 32). Taking into consideration the obliteration by edema of 65% of the functional air units at 72 hours, the estimated diffusing capacity fell to 9% of the control value (closed circle on figure 32).

TABLE V

TOTAL ALVEOLAR SURFACE (S_{AT}), TOTAL CAPILLARY SURFACE (S_{CT}), HARMONIC MEAN BARRIER THICKNESS (τ_h) AND AIR-BLOOD BARRIER DIFFUSING CAPACITY (D_m) OF THE TEST GROUPS, EXPRESSED AS PERCENT OF THE CONTROL VALUE

	Time of exposure to 98.5% oxygen (hours)				
	0	6	24	48	72
S_{AT} (m^2)	.38	.34	.36	.39	.32
S_{CT} (m^2)	.34	.30	.33	.32	.17*
τ_h (μ)	.45	.42	.44	.51	.90*
D_m test $\frac{D_m \text{ test}}{D_m \text{ control}}$ (%)	100	95	99	83	25

* $p < 0.01$

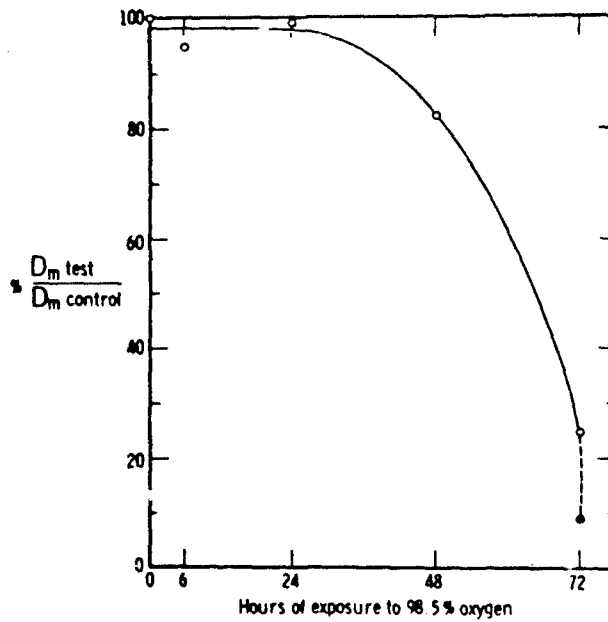

Figure 32. DIFFUSING CAPACITIES
Air-blood barrier diffusing capacity (D_m) of the test groups, expressed in percent of the control value (see text).

CONCLUSIONS

The primary site of damage caused by pure oxygen breathing at 765 Torr appeared to be in the endothelial cells of the pulmonary capillaries with resultant movement of fluid into the interstitial and alveolar spaces.

After 72 hours of oxygen exposure, the alveolo-capillary tissue barrier had doubled in thickness, the capillary bed was reduced in volume by about one half, and a profuse exudate containing numerous cells had covered about 65 percent of the alveolar surface. These factors combined to progressively reduce the estimated diffusing capacity of the air-blood barrier to about 9 percent of its normal value.

PART I REFERENCES

1. Roth, E. M., Space Cabin Atmospheres, Part I. Oxygen Toxicity, NASA SP-47.
2. Becker-Freyseng, H., and H. G. Clamann, German Aviation Medicine in World War II, Vol. 1, pp 493-514, 1950.
3. Clamann, H. G., and H. Becker-Freyseng, Luftfahrtmedizin Vol 4, p 1, 1939.
4. Comroe, J. H., R. D. Dripps, P. R. Dumke, and M. Deming, J. A. M. A., Vol 128, p 710, 1945.
5. Öhlsson, W. T. L., Acta Med. Scand., Suppl. 190, pp 1-93, 1947.
6. Welch, B. E., T. E. Morgan, F. Ulvedal, and W. W. Henderson, Aero-space Med., Vol 32, p 7, p 583, p 591, p 603, p 610, 1961.
7. Caldwell, P. R. B., W. L. Lee, Jr., H. S. Schildkraut and E. R. Archibald, J. Appl. Physiol., in press 1966.
8. Ernsting, J., J. Physiol., Vol 155, p 51, 1961.
9. Campbell, J. A., J. Physiol., Vol 63, p 325, 1927.
10. Helvey, W. M., Final Report, RAC 393-1, ARD 807-701, Republic Aviation Corp., 1962.
11. Cook, S. F., and H. F. Leon, AFMDC-TR-60-21, Holloman Air Force Base, New Mexico, 1960.
12. Penrod, K. E., Final Report, Contract NONR 473(00), 1959, (AD No. 218 094).
13. Caldwell, P. R. B., S. T. Giammona, W. L. Lee, and S. Pondurant, Ann. N. Y. Acad. Sci., Vol 121, p 823, 1965.

REFERENCES (CONT'D)

14. Cedergren, B., L. Gyllensten, and J. Wersall, Acta Pediat., Vol 48, p 477, 1959.
15. MacHattie, L. and H. Rahn, Proc. Soc. Exp. Med. Biol., Vol 104, p 772, 1960.
16. Clamann, H. G., H. Becker-Freyseng, and G. Liebegott, Luftfahrtmedizin, Vol 5, p 17, 1941.
17. Pichotka, J., Beitr.z.path.Anat. u.z. allg.Path., Vol 105, p 381, 1941.
18. Liebegott, G., Beitr.z.path.Anat. u.z. allg.Path., Vol 105, p 413, 1941.
19. Paine, J. R., D. Lynn, and A. Keys, Amer. J. Physiol., Vol 133, p 406, 1941.
20. Weir, F. W., D. W. Bath, P. Yevich, and F. W. Oberst, A Study on the Effects of Continuous Inhalation of High Concentrations of Oxygen at Ambient Pressure and Temperature, ASD-TR-61-664, Aeronautical Systems Division, Wright-Patterson Air Force Base, Ohio, 1961.
21. Pratt, P. C., Ann. N. Y. Acad. Sci., Vol 121, p 809, 1965.
22. Schulz, H., Die Naturwissenschaften, Vol 9, p 205, 1956.
23. Weibel, E. R., Morphometry of the Lung, Springer, Heidelberg, 1963.
24. Weibel, E. R., Handbook of Physiology, Section 3, Vol 1, p 285, 1964.
25. Byers, D. H., and B. E. Saltzman, Am. Ind. Hyg. Assoc. J., Vol 19, p 251, 1958.
26. Thorp, C. E., Armour Research Foundation, pp 118-119, 1955.
27. Luft, J. H., J. Biophys. Biochem. Cytol., Vol 9, p 409, 1961.
28. Reynolds, E. S., J. Cell Biol., Vol 17, p 208, 1963.
29. Weibel, E. R., and B. W. Knight, J. Cell Biol., Vol 21, pp 367-384, 1964.
30. Weibel, E. R., Lab. Invest., Vol 12, p 131, 1963.
31. Hennig, A., Z.wiss.Mikr., Vol 63, pp 67-71, 1956.
32. Hennig, A., Mikroskopie, Vol 11, pp 1-20, 1956.
33. Chalkley, H. W., J. Cornfield, and H. Park, Science, Vol 110, p 295, 1949.
34. Weibel, E. R., and D. M. Gomez, J. Appl. Physiol., Vol 17, pp 343-348, 1964.

PART II

ELECTRON MICROSCOPIC AND MORPHOMETRIC STUDY OF RAT LUNGS EXPOSED TO 97 PERCENT OXYGEN AT 258 TORR (27,000 FEET)

INTRODUCTION

Due to the continuous and expanding progress in space exploration, the importance of low pressure environments as well as of monogas atmospheres has rapidly increased. In spite of the continuous use of pure oxygen at 5 psia as breathing gas in all manned space flights of the United States, up to now the information available about possible side effects of such artificial environments is still scanty.

This study was undertaken to elucidate the effects of breathing essentially pure oxygen at 5 psia for up to 2 weeks on rat lungs. In our previous studies on the pathology of oxygen toxicity to the rat lung (in part I of this paper and reference 3), it had been possible to define the damages to the lung caused by breathing pure oxygen at 765 torr quantitatively by applying morphometric techniques. The same methods were thus employed in this study in an attempt to detect correlaries to actual oxygen poisoning or to evaluate quantitatively whatever changes should be found in rat lungs breathing oxygen at 5 psia.

MATERIAL AND METHODS

OXYGEN EXPOSURE EXPERIMENTS

Specifications of the environmental chamber used

The chamber at the Aerospace Medical Research Laboratories, Wright-Patterson Air Force Base, Ohio, used in these experiments has been described in detail in part I of this paper and reference 1. The oxygen source consisted of cylinders of gaseous aviators breathing oxygen with a minimum concentration of 99.5%. Carbon dioxide produced by the experimental animals during oxygen exposure experiments was eliminated from the chamber atmosphere by absorption in lithium hydroxide canisters; odors were removed by activated charcoal. Temperature and humidity were controlled by a cooler system.

The main parameters of the chamber atmosphere were continuously recorded. The carbon dioxide concentration was not monitored continuously during our experiments. From previous experience, however, no buildup of carbon dioxide in the chamber was expected. Mass spectrometer analyses of chamber atmosphere samples performed during these experiments confirmed this premise. The presence of toxic contaminants in the chamber atmosphere had been excluded in a separate study by means of periodic mass spectrometer analysis (ref 3).

The characteristics of the chamber atmosphere during oxygen exposure of the test animals are given in table I:

TABLE I

COMPOSITION OF CHAMBER ATMOSPHERE DURING OXYGEN EXPOSURE OF RATS AT 258 TORR

Total pressure:	258 torr (27,000 feet)
Oxygen partial pressure:	251 \pm 5 torr
Oxygen concentration	97 \pm 2%
Carbon dioxide concentration:	below 0.1% (see text)
Relative humidity:	45 \pm 6%

The \pm values represent one standard deviation.

Animals used

Of 74 male Sprague-Dawley rats* born on the same day, a sample of 37 animals was simultaneously exposed to oxygen at 258 torr for the following periods:

Experimental group A ₁	1 day
Experimental group A ₂	5 days
Experimental group A ₃	14 days

Ten randomly selected rats were sacrificed before the exposure experiments as gross quality controls (QA). The remaining 27 rats served as actual controls (CA) for comparison with the test animals; they were kept in room air under otherwise identical conditions and were sacrificed at the end of the experiment. The incidence of murine pneumonia in the various groups is shown in table II:

TABLE II

NUMBER OF ANIMALS AND INCIDENCE OF MURINE PNEUMONIA IN THE VARIOUS GROUPS OF THE PRESENT STUDY

Group	Total number of experimental animals	Number of animals with murine pneumonia	% incidence of murine pneumonia
QA	10	1	10%
CA	27	3	11%
A ₁ -A ₃	37	9	24%

*purchased from Holtzman Company, Madison, Wisconsin

For the electron microscope studies reported below, only lungs free of any signs of murine pneumonia were used. Animals that appeared to have pneumonia because of wheezing had been eliminated during the course of the experiment. During preparation of the lungs, specimens with clearly recognizable signs of pneumonia were withdrawn. Of the remaining lungs, five were used in each group for quantitative study. Their characteristics are given in table III.

Incidents in chamber operation

A number of incidents occurred in the course of the experiment. Initial reduction of chamber pressure caused the watering bottles to empty into the cages. This resulted in a temporary rise in relative humidity to 78%. Subsequent troubles with the sampling pumps made frequent flushing of the chamber with oxygen necessary, which caused a temporary temperature drop to 68 F. Following repair of the sample system, the cooler was ineffective for a time due to the high humidity, and the temperature subsequently rose to 83 F. These conditions were completely remedied, however, within the first 30 hours of the study. Group A₃ (14 days of oxygen exposure) was in the chamber at this time.

Eleven hours before completion of the study, the chamber door seal broke. The chamber pressure rose to ground level within about 30 seconds. This is described as a slow compression. The oxygen concentration fell to 84%. The entry check door was closed and the chamber was taken to 282 torr (25,000 feet), where the oxygen partial pressure could be maintained at 252 torr (89% concentration) for the remainder of the exposure period. Group A₃ was in the chamber at this time.

PREPARATION OF LUNGS AND MORPHOMETRIC METHODS

Details on the standardized procedures used in this study for fixation of the lungs, as well as for preparation of specimens for light and electron microscopy are given in part I of this paper. This processing took place at the Aerospace Medical Research Laboratories immediately after the animals were removed from the chamber.

The principles for quantitative evaluation of our data as well as the sampling procedures and the statistical methods used are also given in part I of this paper.

RESULTS

GENERAL OBSERVATIONS

No abnormal behavior was observed in the test animals when they were transferred from the chamber atmosphere to room air at the end of the experiment. They breathed quietly and on the whole appeared healthy, except that the incidence of murine pneumonia was increased in the test groups (table II). The diseased rats were excluded from further study.

One striking finding was a loss in body weight of the test animals. While the 1-day (A₁) and 5-day (A₂) groups actually lost weight, the 14-day (A₃) group did not gain the weight expected from their growth curve. Figure 1 gives the average

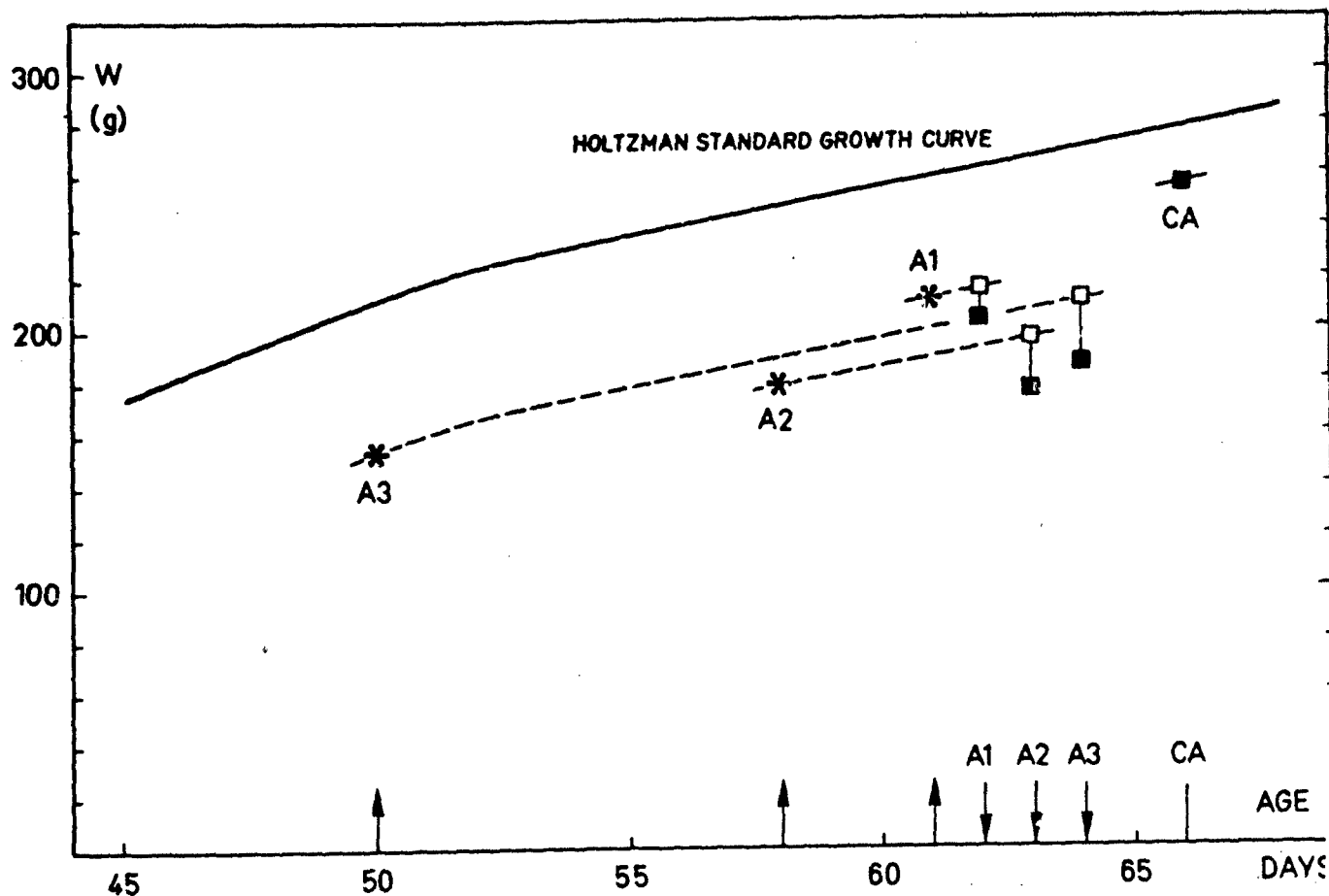

Figure 1. AVERAGE BODY WEIGHT OF EXPERIMENTAL ANIMALS AT ENTRY (*) AND AT SACRIFICE (■), AS COMPARED WITH STANDARD GROWTH CURVE OF HOLTZMAN MALE SPRAGUE-DAWLEY RATS.

Dotted lines indicate weight gain expected from normal growth trend. Actual weight at sacrifice (■) is reduced with respect to expected weight (□).

A₁ to A₃: test groups, CA: control group (compare with table II)

↑ entry into chamber, ↓ exit from chamber and sacrifice

rowth curve of Holtzman rats. The weights registered at entry to the chamber are lotted as asterisks and expected growth trends are given as dotted lines. It is clearly seen that the weight registered at exit (squares) is over 10% below the expected weight. The relatively high weight of the control rats (CA) reflects in part bias in selecting "healthy" animals for controls.

The lung volume measured after standardized inflation showed a decrease from 8 to 6 ml in the groups $A_1 - A_3$ (table III), which is highly significant by variance analysis ($P < .01$). The lung volume-to-body weight ratio also decreased from A_1 to A_3 .

QUALITATIVE LIGHT AND ELECTRON MICROSCOPIC OBSERVATIONS OF LUNG SECTIONS

In none of the test animals could any pathologic changes be observed in light and electron microscope preparations; over 600 electron micrographs were evaluated. In particular the alveoli were free of any edema as had been observed in rat lungs exposed to pure oxygen at 765 torr. The alveolar capillaries and the tissue appeared normal as can be seen in the electron micrograph (figure 2), from specimen of an animal exposed to oxygen at 258 torr for 2 weeks (A_3).

The only deviation from normal was an apparent increase in the number of eosinophilic granulocytes within the lung capillaries in those animals which had been exposed to oxygen for 5 and 14 days.

MORPHOMETRIC FINDINGS*

The total alveolar surface area (S_A) was estimated independently on two sets of preparations, light microscopically on PAS-stained celloidin-paraffin sections and electron microscopically on Epon sections (figure 3). The absolute values of the two measurements may not be compared directly, since the light microscopic measurements are affected by considerable systematic errors due to tissue shrinkage and section thickness for which no correction has been introduced.

Both measurements, however, show the same trend, namely a decrease in S_A proportional to the duration of the experiment. In the analysis of variance this decrease was found to be highly significant with an error probability $P < .001$.

Figure 4 shows a concurrent decrease of capillary volume (V_C) and surface area (S_C), while the ratio of capillary per alveolar surface remained unchanged throughout. The reduction of V_C and S_C from A_1 to A_3 was found to be significant at the level of $P < .05$ by variance analysis. The number of erythrocytes counted per field measurement also showed a concurrent reduction from A_1 to A_3 .

Slight differences were found in the thickness of the air-blood tissue barrier (figure 5). The most striking change was found in the average thickness in group A_1 which had remained in the chamber for 1 day only. It is particularly noteworthy that the variance of the data is much larger in A_1 than in the other groups. This

In all graphs the two brackets above and below the average point enclose two standard errors (SE).

TABLE III

MAIN VITAL CHARACTERISTICS OF RATS USED IN THE 5 PSIA OXYGEN EXPOSURE EXPERIMENTS

Group	Number of animals used for morphometry	Days of oxygen exposure	Age in days at start of exposure	at sacrifice	Average body weights at entry into chamber (g)	at exit of chamber (g)	Volume of fixed lungs (standard inflation) (ml)	Ratio of lung volume to body weight at exit average (ml/g)
CA	5	--	--	66	--	255.4 ± 15.7	7.70 ± 0.71	0.030
A ₁	5	1	61	62	210.6 ± 30.1	205.8 ± 11.7	8.22 ± 1.22	0.040
A ₂	5	5	58	63	178.4 ± 4.9	175.4 ± 14.9	5.96 ± 0.37	0.034
A ₃	5	14	50	64	152.8 ± 8.7	187.8 ± 9.0	5.80 ± 0.84	0.031

The ± values indicate one standard deviation.

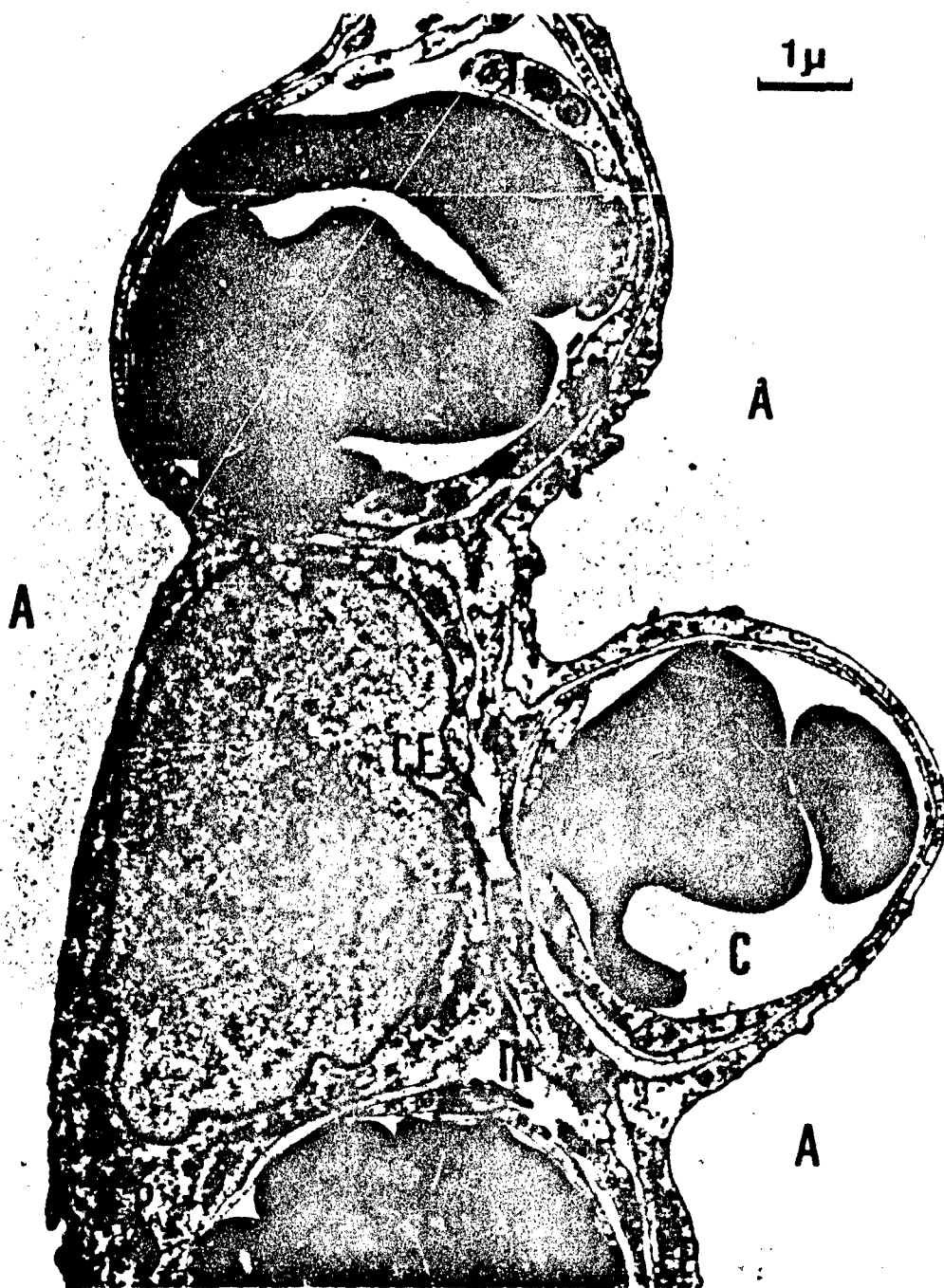

Figure 2. ELECTRON MICROGRAPH OF ALVEOLAR CAPILLARIES OF RAT LUNG EXPOSED TO 97% OXYGEN AT 258 Torr FOR TWO WEEKS. Alveoli (A), capillaries (C), capillary endothelium (EN), alveolar epithelium (EP), and interstitium (IN) have normal appearance. EC: erythrocyte, N: nucleus, CF: collagen fibrils, FB: fibroblast, T: thrombocyte. Magnification 13,000 x.

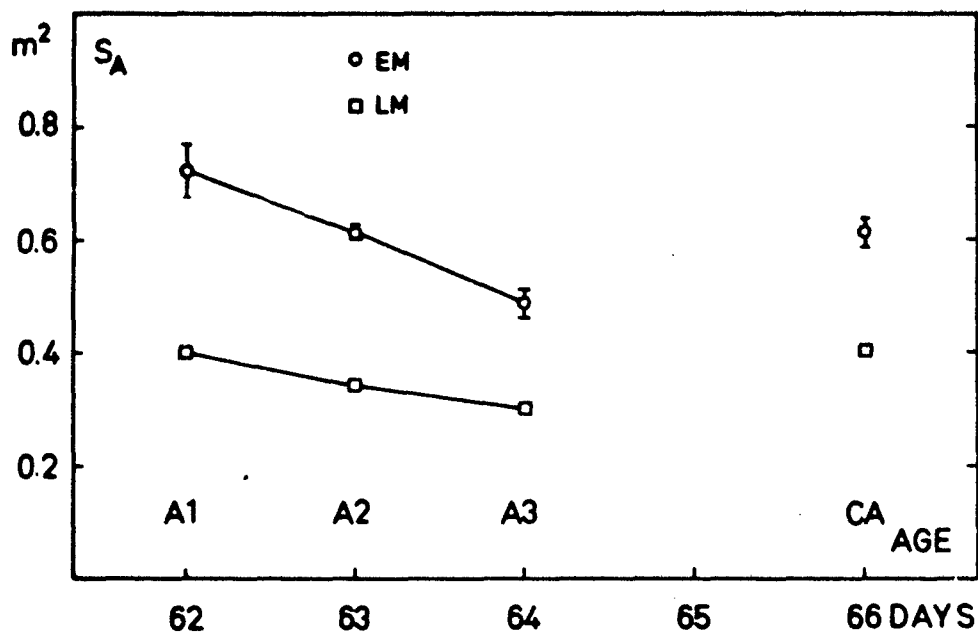

Figure 3. TOTAL ALVEOLAR SURFACE AREA (S_A) OF CONTROL (CA) AND TEST ANIMALS, ($A_1 - A_3$) AS MEASURED BY ELECTRON MICROSCOPY (○), AND LIGHT MICROSCOPY (□). Compare text.

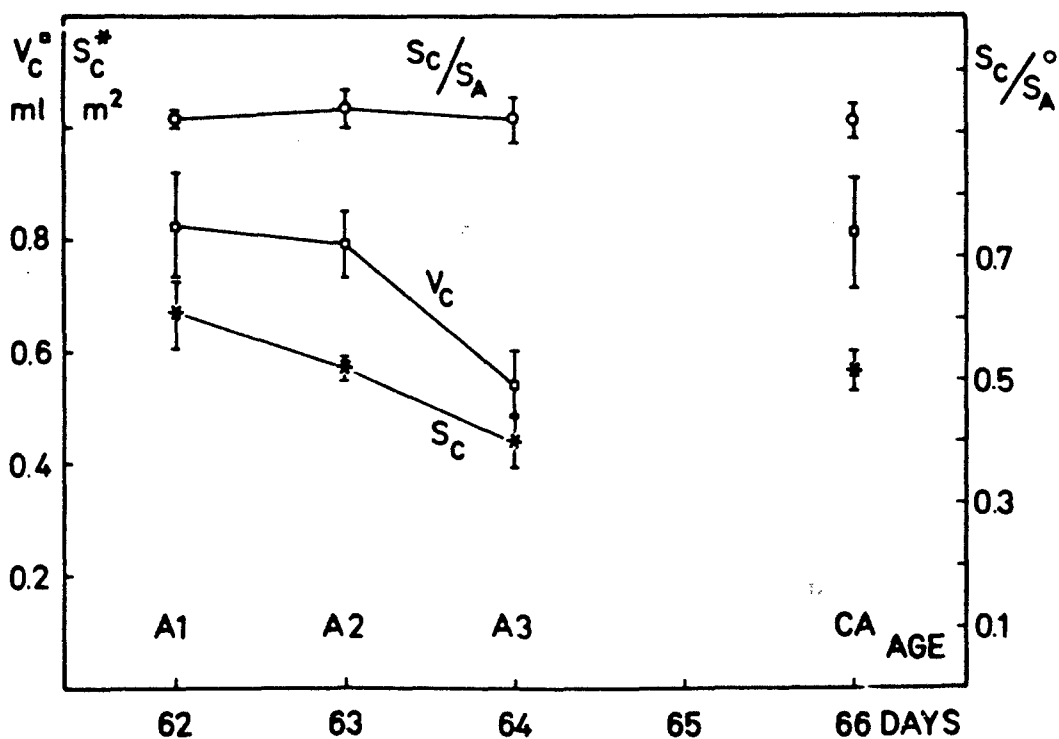

Figure 4. CHANGES IN CAPILLARY VOLUME (V_C) AND SURFACE AREA (S_C). Capillary-to-alveolar surface area (S_C/S_A) remains unchanged.

may indicate some inhomogeneous changes taking place in the tissue during the first day of the experiment. The harmonic mean barrier thickness, an estimate of the diffusion resistance in the tissue, shows a slight drop which is, however, statistically barely significant ($P < .05$). The composition of the barrier remained unchanged throughout the experiment (figure 6).

INTERPRETATION OF THE MORPHOMETRIC FINDINGS

Interpretation of these changes is rendered difficult for two reasons:

- 1) the test animals were growing rats in their most active growth phase; they were 50 days old at the start of the experiment and reached 64 days at termination.
- 2) The groups have not been matched with respect to body size. This is particularly serious with respect to the control group for which "fat, healthy animals" were selected. This group is, therefore, eliminated from further consideration. We will only consider changes occurring between the experimental groups A_1 to A_3 .

Growth of lung

In a separate study on lung growth (ref 4) the alveolar surface area S_A as well as the size of the capillary bed were found to increase with age proportional to the $3/4$ power of body weight. Based on these data the expected growth of S_A for our groups of rats could be plotted with respect to age (figure 7). Figure 7 shows that S_A is reduced to 76% of the expected value in A_3 and to 85% in A_2 , while A_1 appears to have approximately the alveolar surface area expected. Extrapolating back, the expected surface area at entry of the test animals into the chamber could be estimated. It appears now that S_A has stopped growing for the duration of the experiment. For group A_2 this goes along with the observed cessation of weight gain during the 5 days in the chamber (figure 1). In A_3 however, the body weight did increase by 30 g on the average during the experiment. Hence, there was an actual loss in alveolar surface area, as will be outlined below.

Group matching

The interpretation of these results becomes somewhat doubtful, however, since the groups had not been carefully matched at the start of the experiment. If the growth trends are considered (figure 1), there is an average weight difference of 50 g or 25% between control group CA and test group A_2 , while the other groups are well matched in between. Between test groups the difference is of the order of 10-20 g or 10%.

On the other hand, double variance analysis of the data shows that the material investigated in each group was very homogeneous. This is reflected in the small error probabilities found for the group differences in S_A . A common denominator for all groups which would eliminate the weight differences is found in the ratio S_A/W , that is in the "specific gas exchange surface" per unit body weight (m^2/KG). Figure 8 reveals that the average specific gas exchange surface falls from 3.46 to 2.54 between A_1 and A_3 . This fall is accentuated if expected weights at exit from chamber were taken instead of measured weights.

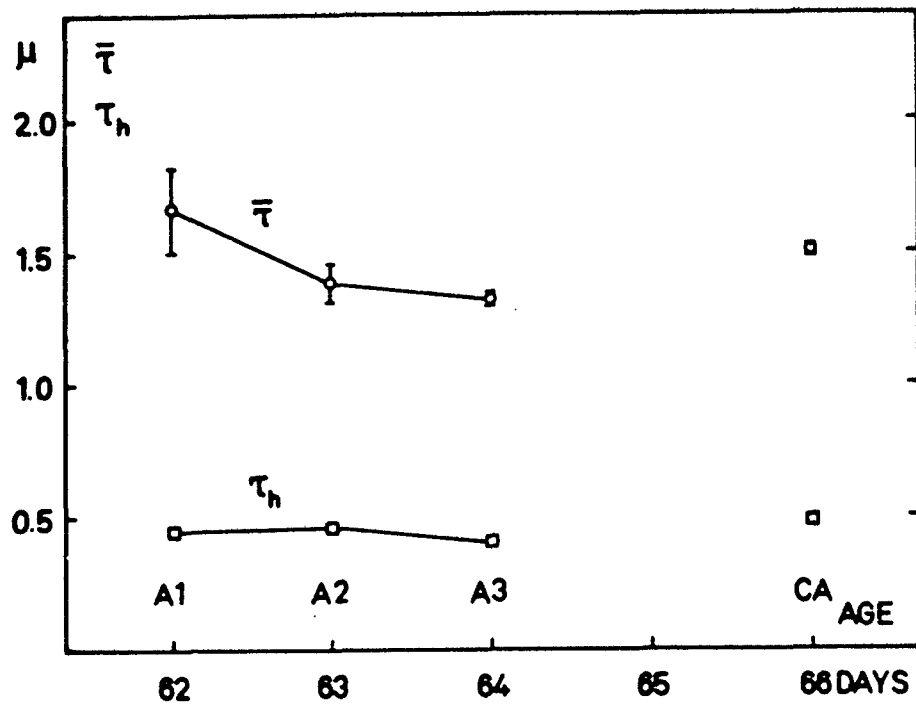

Figure 5. ARITHMETIC MEAN ($\bar{\tau}$) AND HARMONIC MEAN (τ_h) OF THICKNESS OF AIR-BLOOD BARRIER.

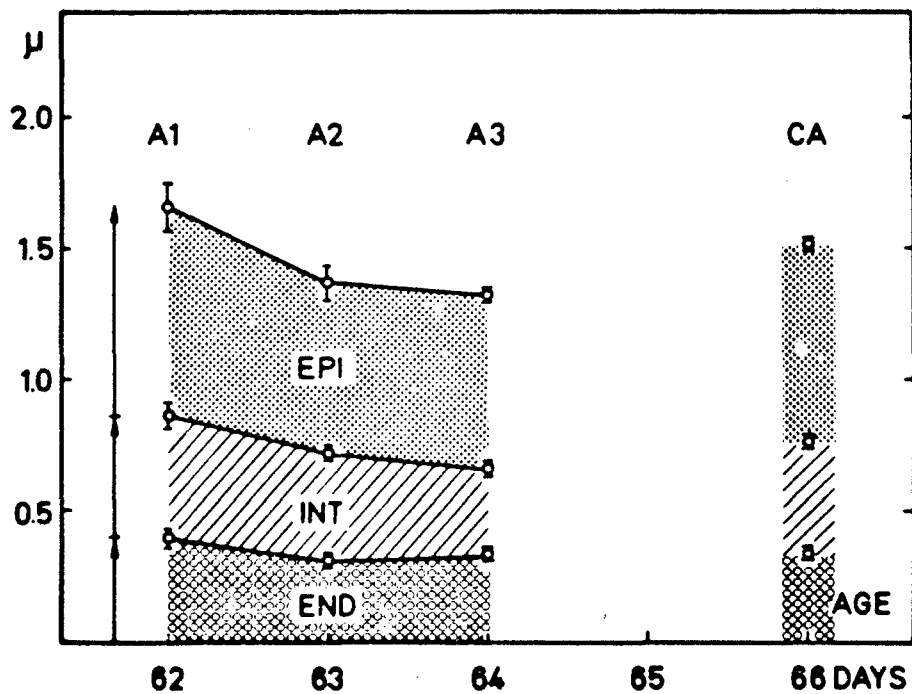

Figure 6. PARTIAL THICKNESS OF CAPILLARY ENDOTHELIUM (END), INTERSTITIUM (INT), AND ALVEOLAR EPITHELIUM (EPI) IN AIR-BLOOD BARRIER.

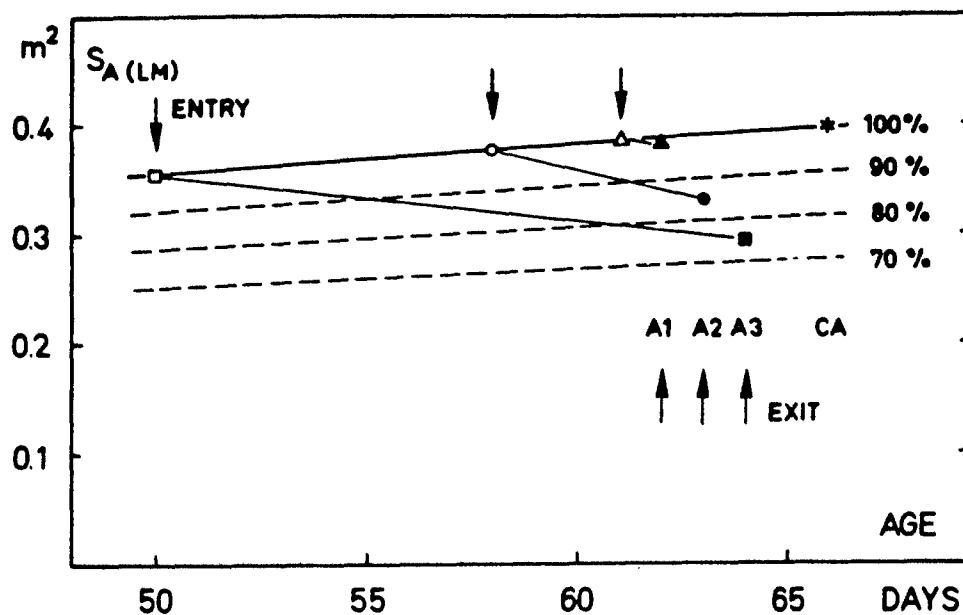

Figure 7. EXPECTED GROWTH TREND (SOLID LINE) OF ALVEOLAR SURFACE AREA (S_A) AS DERIVED FROM (5). Open symbols on solid line indicate "expected" S_A at time of entry of test rats into chamber; full dots represent light microscope measurements of S_A at sacrifice as given in figure 3; note reduction to 75% of expected value in A_3 . Asterisk (CA): control value.

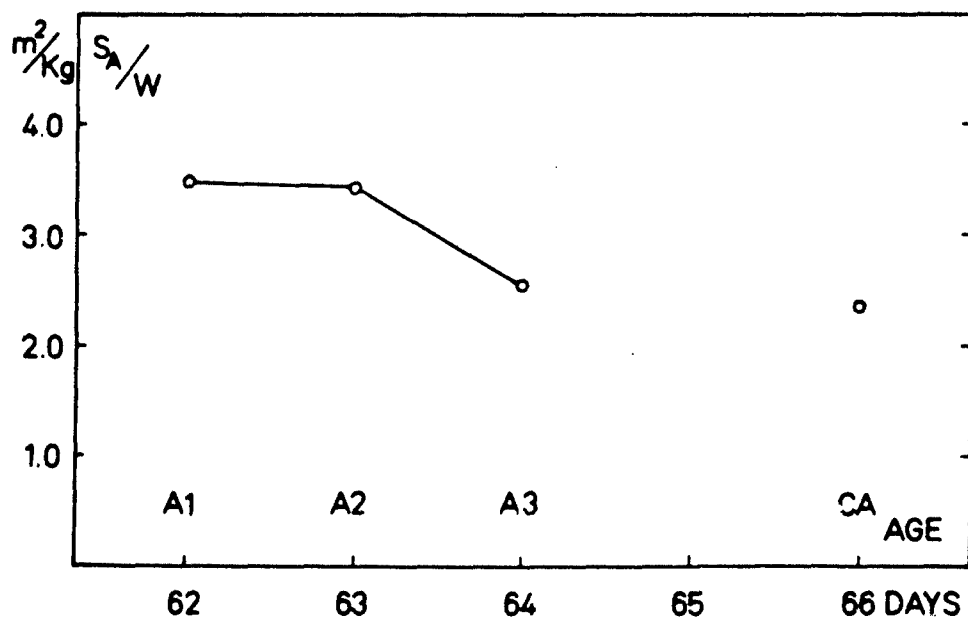

Figure 8. CHANGES IN "SPECIFIC GAS EXCHANGE SURFACE" (S_A/W) DEPENDING ON TIME OF EXPOSURE.

The specific gas exchange surface of CA is only 2.34. This low value is possibly related to the high body weight of these animals in two ways. First, it has been shown in our growth study (ref 4) that S_A/W falls with the fourth root of body weight. Second, because of selection of "fat, healthy" rats as controls, obesity may account for a good portion of body weight, so that the "specific gas exchange surface" of the controls may not be directly comparable to that in non-obese test animals. Arbitrary deduction of 40 g from the CA weight as contribution of fat would bring it into the range of expected weights for the test groups at 66 days (figure 1), and consequently S_A/W would rise to 2.84. However, it is safer to disregard the control value of S_A/W altogether.

As a final result we thus obtain a reduction of the specific gas exchange surface in the test rats which breathed pure oxygen at 258 torr for 2 weeks, as compared with the group with shorter exposure times. The changes observed in capillary volume and surface are entirely in keeping with this finding, since we had found that the capillary density per alveolar surface area remained unchanged throughout the experiment.

DISCUSSION

The present study on lungs of young rats exposed to 97% oxygen at 258 torr for 1, 5, and 14 days has not shown any reaction in the respiratory tissue which could be interpreted as oxygen poisoning as it has been quantitatively defined in part I of this paper and reference 3. Light and electron microscope revealed no pathologic findings in the various groups; all appeared normal. The apparent increase in eosinophilic granulocytes within lung capillaries needs further investigation.

The morphometric analysis, however, revealed a significant decrease of alveolar surface area, as well as of capillary volume and surface, proportional to the duration of the experiment, while the air-blood tissue barrier remained practically unchanged. In spite of difficulties in comparing the various groups the "specific gas exchange surface" of the lung, i. e., the gas exchange surface available per unit body weight, showed a highly significant reduction by 27% in the group that remained in the chamber for two weeks (A_3), as compared with A_1 .

This change cannot be interpreted as a result of oxygen toxicity in its actual sense, since it is not accompanied by any detectable tissue or cell damage. While various explanations for this finding may be proposed, it appears to reflect essentially an adaptation of the gas exchange apparatus to the altered environment. The ambient pO_2 being of approximately 250 mm Hg the rats were offered an excess of oxygen of over 50%. It can thus not be excluded that the organism will adapt to this environment by reducing the gas exchange surface of its lung. For the lung such adaptive processes have to our knowledge never been observed. However, they are well known for other systems: the increase in hematocrit, hemoglobin concentration and erythrocyte number at high altitude is directly related to the respiratory system; hypertrophy and hypotrophy of bone occurring with increased and reduced functional loads are well-known adaptive processes.

Before a definitive interpretation can be reached a series of complementary studies is required. It must be studied whether the same changes occur in adult

its to rule out a simple effect on growth rate of the lung. Furthermore, test animals should be offered a breathing mixture of air with a pO_2 of 250 torr at ambient pressure. It is hoped that some of these studies can be performed in the near future.

CONCLUSIONS

The morphometric electron microscope study of lungs exposed to 97% oxygen 5 psia (258 torr) revealed a reduction in specific gas exchange surface by about 50% after 2 weeks, with a concurrent decrease in capillary volume and surface. This change is interpreted as an oxygen effect, but cannot be called "oxygen toxicity". It is rather regarded as an adaptive process of the (growing) organism increased availability of oxygen in the breathing medium.

PART II REFERENCES

Felig, P., and W. L. Lee, Jr., "Effects of Sodium Lactate on Oxygen Toxicity in the Rat". Ann. N. Y. Acad. Sciences. 121: 829, 1965.

Kistler, G. S., P. R. B. Caldwell, and E. R. Weibel, "Quantitative Electron Microscope Studies of Lung Damage in Rats Breathing 98.5% Oxygen at 767 Torr. A preliminary Report". In: Symposium on Hyperbaric Medicine, Durham, N.C. 1965 (in press).

Caldwell, P. R. B., W. L. Lee, Jr., H. S. Schildkraut, and E. R. Archibald, "Changes in Lung Volume, Diffusing Capacity and Blood Gases in Men Breathing 98% Oxygen at 760 Torr". Proc. 6th Aspen Conf. 1963 (in press).

Weibel, E. R., "Postnatal Growth of the Lung with Respect to Gas Exchange Capacity". In: Ciba Fdn. Symposium Lung Development 1965. London: Churchill (in press).

ACKNOWLEDGMENT

The research reported in this paper has been sponsored by AEROSPACE MEDICAL RESEARCH LABORATORIES, Wright-Patterson Air Force Base, Ohio, under Contract AF 61(052)-784 through the European Office of Aerospace Research (OAR), United States Air Force.

DISCUSSION

DR. GROSS: I might lead off with an observation which may also be a question and that is that the epithelium seems to be less sensitive than the endothelium of the capillary wall.

DR. KISTLER: That's absolutely true. Even after 72 hours of oxygen exposure at ambient pressure, a large part of the capillaries are destroyed. We can calculate about a 50% destruction of the total capillary bed. We find the larger parts of alveolar epithelial cells look absolutely normal.

MR. WAGNER (Division of Occupational Health Service): Would the altitude of the laboratory for housing your animals in Zürich account for the difference in the body weight curves for the Holtzman rat from those produced here in the United States?

DR. KISTLER: No, I must say these animals were exposed here at Wright-Patterson and we only made the evaluation in Zürich. We randomly sampled electron micrographs. We made a statistical evaluation of our data. I don't know exactly what's the reason for this difference, but I believe some differences in food may account for this. You can feed your animals with pellet food or powder. Ours were fed with pellet food. Maybe this accounts for the difference. However, in a separate study which we made in Zürich we noted that the Holtzman standard growth curve did not completely correlate in body weight and age, but the pattern of growing, of the increasing of body weight with age, is absolutely the same for all the rats we studied.

DR. ROTH (Lovelace Foundation): What sort of electron micrographic changes do you get in murine pneumonia?

DR. KISTLER: Well, in murine pneumonia you get an infiltration with leucocytes. This is one of the most striking findings. There is certainly a very big difference between pictures of animals which have murine pneumonia and the findings which we have here. Leucocytes are found in very large numbers in murine pneumonia. In our oxygen studies we didn't find many leucocytes within the interstitial cells and within the alveoli. Most of the free alveolar cells can be identified as microphages and epithelial cells.

CAPT. KAPLAN (Toxic Hazards Division): I might just make a point to clarify this question about growth rates. This is an important factor in a lot of the studies you're going to hear about. The Holtzman growth curve is a curve that is used by the Holtzman Laboratories that supply these animals and is obtained by evaluating their own animals from birth onward, keeping them there in the breeder's place. You have to remember the animals we're dealing with here have been transported from the breeder to the laboratory, then have been handled, have been moved from the animal facility into exposure chambers, out of exposure chambers, have been weighed at various times, and have been numbered; and we have found that just the act of transporting them from the breeder to the laboratory usually induces a transient weight loss due to handling and anxiety among the animals. As to many of these other things, the weight changes, especially when measured only 1, 2, or 3 days after putting the animal in the chamber, often fall off the curve.

think this explains why, although the pattern was the same, the initial weight of these animals lagged a little bit behind the standard curves that the breeders give you.

DR. SCHAEFER (U. S. Naval Medical Research Laboratory): Have you done any correlative studies of arterial oxygen saturation and carbon dioxide gradients to correlate it with your barrier thickness? The question I really have is: after 3 days the animals are in a relatively good clinical shape but you have a large increase in barrier thickness which would actually call for changes in oxygen and carbon dioxide gradient and maybe cause carbon dioxide retention. Are there any pulmonary studies done which correlate with your anatomical, morphological studies?

DR. KISTLER: Well, I would say our animals after 3 days of oxygen exposure at 765 torr were in pretty bad shape. We have not made studies on oxygen saturation or anything like that, but in a study that was done here at Wright-Patterson by Dr. Caldwell 2 years ago they measured the diffusing capacity of the lung in humans after oxygen exposure at the same pressure. Our findings correlate very well in the time of the onset of a functional decrement. The diffusing capacity of the membrane and the diffusing capacity of the lung are correlated with each other and they observed a decrease in the diffusing capacity of the lung measured by physiologic means at the same time when morphometrically an increase in barrier thickness, as well as the destruction of capillaries, is demonstrated.

DR. THOMAS: Just to clarify this point. We didn't talk about this run in the morning when we discussed the oxygen exposures at near ambient pressure in the meses. These animals were moribund and died "according to the book" from 72 hours on; moreover, this is a different chamber with a recirculating system. The two sets of experiments are not directly comparable. These animals were very sick at 72 hours.

DR. KISTLER: That is correct.

ELECTRON MICROSCOPIC INVESTIGATIONS OF OXYGEN EFFECTS ON LIVER TISSUE

Fenton Schaffner, M.D.

Mount Sinai School of Medicine
New York, New York

INTRODUCTION

This report is a resume of electron microscopic studies of livers of rats, dogs, and monkeys over the past two years, carried out with the help of Dr. Franklin M. Klion and Mrs. Esther Trachtenberg, mainly on tissue submitted to us from both Wright-Patterson Air Force Base and Brooks Air Force Base. Some of the results have already been published (ref 1, 2), and some have been submitted for publication (ref 3).

The purposes of these studies were to determine the ultrastructural changes which occur in a metabolically active organ during hyperoxia to gain some insight into the nature of "oxygen toxicity" on a cellular level and to see whether adaptation to the new atmosphere develops. Concomitant biochemical studies were carried out on the same tissues by the personnel at the respective Air Force installations (ref 4, 5, 6).

MATERIAL AND METHODS

The livers of rats, dogs, and monkeys exposed to oxygen with continuous monitoring of atmospheric parameters under pressures of 258, 380, 760, and 2280 mm Hg were obtained after from 3 hours to 8 months, were removed or biopsied from the still living animal, and fixed in 1% osmium tetroxide buffered with veronal acetate, phosphate, or s-collidine. The specimens were dehydrated and embedded in epoxy resin. Sections were cut with an LKB Ultratome, stained with lead citrate or lead hydroxide and examined with a Hitachi HS 7 electron microscope. Sections 1 μ in thickness stained with toluidine blue and PAS were also studied with the light microscope.

RESULTS

All of the animals studied showed similar changes. These will be described in detail in the rat and comparisons made with the other species.

Rats

In general, the higher the atmospheric pressure the more rapidly hepatocellular alterations appeared. Sprague-Dawley rats showed more severe changes than Wistar rats but no differences could be found between males and females.

The earliest changes which occurred after 2 exposures for 3 hours to 3 atmospheres, after 1 day at 1 atmosphere, and between 3 and 7 days at 1/3 atmosphere,

were loss of hepatocellular glycogen and enlargement of mitochondria. Adjacent light and dark cells were also seen and these were occasionally found at all time periods. The mitochondria were not decreased in density, and, therefore, were not swollen by imbibition of water. The number of cristae per mitochondrion was increased as was the length of the cristae. In places cristae traversed the entire width of the mitochondria and in some a single crista seemed to split the mitochondrion in half. Several mitochondria per cell were constricted in their middle as though they were dividing in half. In addition, several mitochondria in the pericanalicular zone of each cell, especially after 1 week at 258 mm Hg, had thickening and darkening of the surrounding membranes and the entire structure was surrounded by a thin membrane forming an autophagic vacuole. Occasionally such vacuoles contained other cytoplasmic elements although mitochondria predominated. At this time there was great variation in size and shape with very elongated forms up to 5 μ in length and sometimes with branching. The profiles of rough endoplasmic reticulum and the tubular smooth endoplasmic reticulum were normal, except that around the large mitochondria several profiles were closely applied. Polyribosomes were present in large clusters, in places apparently coalescing to form new rough profiles. The Golgi apparatus appeared enlarged. After 2 weeks the variation in size of mitochondria was much less evident and many mitochondria showed a small myelin figure at one end. This seemed to have the same density as the mitochondrial membranes in the autophagic vacuoles. After 30 days at 258 mm Hg, these had disappeared. The glycogen depletion, enlarged mitochondria, polyribosome clusters, and autophagic vacuoles persisted. At this time Kupffer cells were enlarged and contained numerous lysosomes. After 90 days at 258 mm Hg, glycogen was again normal as was the remainder of the cytoplasm, except that in the pericanalicular zone many lysosomes, resembling lipofuscin pigment granules were present and a few autophagic vacuoles still contained recognizable organelles. Some enlarged Kupffer cells persisted. After 8 months at 258 mm Hg, the picture was quite similar to that seen at 90 days, although the amount of glycogen was less, the variation in size and shape of mitochondria was somewhat greater and the Golgi apparatus larger than in normal controls. Light and dark cells were also still seen.

At no time were the cell membranes or bile canaliculi abnormal, nor was the collagen stroma in the dense space increased. The sinusoidal endothelial lining layer appeared normal throughout and no other mesenchymal cells appeared.

Dogs

Of the three species studied the least changes in glycogen were present in dogs. Mitochondrial alterations were present and after 8 months at 258 mm Hg this was greatest in this species. In addition, some mitochondria contained linear arrays of crystalline material. Some light and dark cells were present. The most striking finding at this time was the large number of pigment-containing lysosomes and autophagic vacuoles.

Monkeys

In this species the glycogen depletion was the same as in the rats. The mitochondrial changes were less striking and did not follow as clear a time sequence as in the rats. In addition, at 3 days at 258 mm Hg tubular smooth endoplasmic reticulum was increased, apparently at the expense of the rough profiles. Most of

the changes were gone after 2 weeks but were seen again at 8 months. At this time pigment granules and autophagic vacuoles were numerous around bile canaliculi and a few light and dark cells were seen.

DISCUSSION

An increase in the amount of oxygen in the inspired air primarily affects mitochondria. This has been seen morphologically with the help of the electron microscope in the liver (ref 1, 2) and in the tubular cells of the kidney (ref 7). The hepatic changes seem to be nonspecific and do not appear to be sufficient to interfere with the well being of the animals. This also can be recognized biochemically by an increase in oxygen consumption with uncoupling and a decrease in oxidative phosphorylation (ref 4, 5). Nevertheless, overall liver function as estimated by such serum determinations as bilirubin levels and transaminase activity remained normal (ref 4). Since structural (ref 1, 2) and biochemical (ref 4, 5, 6) alterations become less or even disappear with continued exposure, adaptation to the new environment must be presumed. The mitochondrial myelin figures and the excess of polyribosomes signifying new cellular protein formation can be considered morphologic evidence of this adaptation. The findings of continuing mitochondrial alterations with autophagic vacuole formation in all the animals after 8 months' exposure with normal biochemical findings (ref 6) has suggested that adaptation is a continuing process (ref 3). Whether the livers of the animals exposed to pure oxygen are more vulnerable to other toxic substances or to irradiation before they have become fully adapted remains to be established.

SUMMARY

The livers of rats, dogs, and monkeys exposed to pure oxygen at pressures from 1/3 to 3 atmosphere, from 3 hours to 8 months have been examined electron microscopically. They have been shown to have signs of mitochondrial alteration primarily but adaptation to the new atmosphere occurs although this process appears to be a continual one. Species differences are quantitative rather than qualitative. The major unanswered question is whether the livers of animals so exposed are more sensitive than normals to the action of other toxins.

ACKNOWLEDGMENT

This work was sponsored by the Aerospace Medical Research Laboratories, Aerospace Medical Division, Air Force Systems Command, Wright-Patterson Air Force Base, Ohio, under Contract AF 33(615)-1849.

REFERENCES

1. Schaffner, F., and Felig, P.: "Changes in Hepatic Structure in Rats Produced by Breathing Pure Oxygen", J. Cell Biol., 27: 505-517, December 1965 (AMRL-TR-65-2).
2. Schaffner, F., Roberts, D. K., Ginn, F. L., and Ulvedal, F.: "Electron Microscopy of Monkey Liver After Exposure of Animals to Pure Oxygen Atmosphere", Proc. Soc. Exp. Biol. Med., 1966 (AMRL-TR-66-90).
3. Klion, F. M., Schaffner, F., and Kaplan, H. P.: "Hepatic Effects of Breathing Pure Oxygen for 8 Months Upon Rats, Dogs, Monkeys", AMRL-TR-66-61 (in press).
4. Felig, P.: "Oxygen Toxicity: Ultrastructural and Metabolic Aspects", Aerospace Med., 36: 658-662, July 1965 (AMRL-TR-65-122, AD 627341).
5. Katchman, B. J., Collins, M. L., and Homer, G. M.: The Metabolic Activity of Intact Cell Dispersates from Normal and Oxygen Intoxicated Rats, AMRL-TR-65-173 (AD 630594), Aerospace Medical Research Laboratories, Wright-Patterson Air Force Base, Ohio, December 1965.
6. Riesen, W. H.: "Cellular Biochemistry of Oxygen Toxicity", in Proceedings of the 2nd Annual Conference on Atmospheric Contamination in Confined Spaces.
7. Mautner, W.: "Electron Microscopic Investigations of Oxygen Effects on Kidney Tissue", Proceedings of the 2nd Annual Conference on Atmospheric Contamination in Confined Spaces.

DISCUSSION

DR. COULSTON: Before I ask for questions, may I have the opportunity of saying a few things? I feel very vindicated in my first remarks this morning. I didn't realize the extent to which you had progressed in your work. I would further say that many of the changes that you have described, particularly the mitochondrial changes, we and others have seen with chlorinated hydrocarbons such as DDT, TDE, and with some chlorinated hydrocarbon drugs. The increase in size of mitochondria on an acute basis, the loss of electron density coupled with this increase in size, and then the adaptations (which we like to call physiologic adaptation), we find that many of these compounds can cause these changes. We never refer to it as toxicity because in a matter of days the liver cells will come back to relatively normal. I was particularly intrigued by the large mitochondria which Ortega and our group have also seen with DDT and its analogues. We've come to think of these striations in the mitochondria as perhaps being phospholipids. I was impressed by the lack of increase in fat in these liver cells, which we often see with the enlargement of the mitochondria, and also by the lack of vacuolization. It's the same thing you described in the endoplasmic reticulum. Otherwise, if you showed me some of your pictures, I would say it is the same picture as one might see with DDT, with some minor changes. Now this raises a very important question to me. Is oxygen in this case acting like a chemical insult? We have never seen, to my knowledge, such a tremendous increase in mitochondria which you have. This is unique, as far as I know.

DR. SCHAFFNER: I might say we have studied dieldrin in a similar fashion during our own functional studies and have found that dieldrin, like phenobarbital, is an inducer of microsomal enzyme formation, and that for the integrity of the function of the microsomal enzyme one needs mitochondrial function. So initially with low doses we found endoplasmic reticulum changes, and then when the mitochondria become enlarged the increased enzyme activity begins to fall off. We think that with the chemical inducers like the insecticides the process is first microsomal induction and then mitochondrial damage. With oxygen toxicity it seems to be different because the endoplasmic reticulum is not really altered in these animals. There is no fat as you mentioned. There is some vacuolization, but it is minimal, and it's our feeling that we probably have here a model of the induction of mitochondrial enzymes. The interesting thing is, as you will hear later from the biochemists, the appearance of the enzyme activity and the co-factors are just exactly opposite of what one would find in the presence of damage. So we can have, on one hand, damage, making enlarged mitochondria with one set of biochemical determinations and, on the other hand, induction, making large mitochondria with completely opposite (very early) sets of biochemical determinations. I think it shows that for future electron microscopic studies to be meaningful it will have to be coupled with biochemical determinations.

DR. KISTLER: What you pointed out is absolutely important. At ultra-structural levels cells have not many possibilities to react differently to different noxae. You can find mitochondrial swelling, alteration in the endoplasmic reticulum, clusters of ribosomes, differences in the Golgi apparatus from entirely different noxae. This can be too much oxygen, a loss of oxygen, can be a loss of blood circulation, or it can be any chemical noxae. The cells at this level have not many

ways to react, they always look like that. I think it is very important that we can't call these changes specific. We could call them specific only if we would know that no other noxae than that which we used can produce such changes.

Moreover, I think those changes which you have observed could be classically evaluated by quantitative methods. With a morphometric approach on a large amount of pictures you would certainly be able to determine exactly mitochondrial relationships between the biochemical and physiologic changes, the volume of external surface and internal surface, and even the cell size of the dehydrated or hyperhydrated cells. I think that quantitation would further explain your very interesting findings.

DR. SCHAFFNER: We have talked about quantitative microscopy on the cellular level and, as you know, there's a whole issue of *Laboratory Investigation* recently devoted to this. The problem in the liver is that there are 7 billion cells and we sample at best 100, so to draw any statistically valid conclusions on measurements is a little bit like trying to pull out more than can be done by these pictures. I think this is why we need the biochemistry where the overall picture is sampled for us.

DR. KISTLER: That's the only question on the sample size.

DR. SCHAFFNER: How do you get a statistical sample of 7 billion?

DR. KISTLER: That's easily done.

DR. PATRICK (Laboratory for Experimental Biology): I enjoy the stimulating discussion and I want to bring up one point. Toxicologists have practical problems facing them. You made one statement Dr. Schaffner, and I think there's some truth in it, but are we helping our toxicologists who are our friends, or are we going to leave them in the lurch and say that we can't help them with light microscopy? In effect, if you say you can't see any changes by light microscopy is this any assistance to them? I throw this out to hear your further discussion on that point.

DR. COULSTON: May I take a crack at this first? I don't think anybody has said that light microscopy is useless, and I don't think anybody has said here today the kind of work just described in the previous paper doesn't aid the toxicologist. As a matter of fact, it enables the toxicologist for the first time to actually understand the relationships between the biochemical and physiological changes that are going on in the cell in relation to the chemical moiety. We have never called the changes that were just described toxicity. These are physiologic adaptations that are going on. I'll go one step further. When we think of the kidney, a material passes through the kidney and you urinate it out and some of it is recycled back. Well, I think now we're coming to think of the liver cell as a "kidney" - things have to get through the liver to get in and out of the body - so the changes we are describing, in essence, are the fundamental physiologic changes which occur. Now in our laboratory in Albany we are taking these changes and have reached sophistication at this stage of the game where within a matter of days of acute experiments, 24 hours, 1 hour, 30 minutes after an oral administration of the drug, we can say to the biochemist, "you look here because we think there will be a disclosure there. You go and look at the fats, go look at the triglycerides,

look at the protein synthesis." I think this is the direction we're going and this is what this kind of work is leading the way toward. So what we're saying is this: of course the light microscope is extremely useful when you can see something with it. Now if you can't see anything with it you have another tool to go to, and this is the electron microscope. There are many drugs we've studied wherein we can't see anything with the electron microscope. Nothing happens. Take aspirin. Aspirin does practically nothing. It doesn't induce the enzymes, it doesn't change the liver, it doesn't do anything. So this is just another tool where you find it to be useful. I think the watchword is: when you don't see anything with the light microscope then you do have to look further and use these ultrastructural techniques.

DR. SCHAEFER (U. S. Naval Medical Research Laboratory): It seems to me what you've found is that the liver is pretty resistant against oxygen toxicity and I was interested to see the changes in dark and light cells. This is quite similar to what you find with carbon dioxide where the liver is extremely resistant when compared with the kidney and other organs. Do you have a comment on a comparison of the liver's resistance with other organs? Where does the liver range?

DR. SCHAFFNER: I've heard of Dr. Mautner's kidney studies and I've looked at some lungs. I would agree with you. I think the liver, despite the fact that it's metabolically very active, probably is much more flexible in adapting to all sorts of altered milieus very quickly.

FROM THE FLOOR: I wouldn't like to let one comment of Dr. Kistler's pass. It's too pessimistic. It's true that when you use drugs on the liver, especially the lipid solvents, you get all kinds of alterations that in some phases simulate things we have seen now. But there is one basic difference, and this is: while we saw here after two or three weeks an increase in the number of polyribosomes, with carbon tetrachloride, for example, you get a decrease in the number of polyribosomes. As a matter of fact, you get the depletion of the endoplasmic reticulum and the ribosomes come off, and they are single ribosomes and not polyribosomes. This was also confirmed by biochemical analysis of sucrose gradients on the analytical ultracentrifuge. You have an increase in single ribosomes which also react better to different concentrations of magnesium. Therefore, although at first approximation different kinds of experiments can produce similar changes, like mitochondrial vacuolization droplets, etc., when you look into the endoplasmic reticulum the capacity of the cell to form the dipeptide bonds is remarkably different.

DR. COULSTON: Very good point. Any comment?

DR. SCHAFFNER: Yes. Carbon tetrachloride is probably rather unique among toxic agents in the liver because of its apparent ability to attach to and interfere with the function of membranes. It is toxic even at the very lowest level that Dick Recknagel has been able to use. There is no first induction and then damage. It's damaging even at the tiniest amount very quickly and, as you say, there is separation of the ribosomes from the rough profiles of endoplasmic reticulum which occurs within a few minutes. The other chemical agents behave differently than carbon tetrachloride. I think this is the property of carbon tetrachloride and not a universal phenomenon.

CAPT. KAPLAN (Toxic Hazards Division): This is just a little additional data to support Dr. Schaffner's contention that these changes are adaptive or, at

very worst, reversible. He didn't mention this because it's based only on a preliminary handful of animals. I think it's worth noting because it's supported by independent biochemical determinations on the same animals. One of the groups we exposed was rats at one atmosphere of oxygen for 72 to 96 hours, at which point they were quite sick and showed all the changes you've seen. Several of these animals were not sacrificed but were taken out of their chambers and kept in the ambient environment for 3 to 10 days afterward, at which point they clinically looked better and the electron microscopic picture of the liver had returned completely to normal.

DR. COULSTON: I think what this all shows is that there's more to this business than just the lung. Other organ systems are involved just as well.

ELECTRON MICROSCOPIC INVESTIGATIONS OF OXYGEN EFFECTS ON KIDNEY TISSUE

Willy Mautner, M.D.

Mount Sinai Hospital
New York, New York

INTRODUCTION

Ultrastructural alterations have been demonstrated in the livers (ref 1) and lungs (ref 2) of animals exposed to hyperoxic environments. Some of the changes found after short term exposures were found to be reversible after long term exposures (ref 3). In order to determine whether similar changes are present in the kidney, renal cortical tissues from similarly exposed (or, in some cases, identical) animals were studied by electron microscopy.

MATERIALS AND METHODS

Sprague-Dawley rats weighing 150-200 g were exposed to essentially pure oxygen in a closed system environmental chamber, at 760 mm Hg for 1 and 2 days and at 258 mm Hg for 3 days to 8 months. Monkeys and dogs were similarly exposed at 258 mm Hg for 3 days, 2 weeks, 3 months, and 8 months; and at 380 mm Hg for 15 and 22 days. The exposure facility and its environmental control system is described elsewhere (ref 4). Control animals were maintained in identical cages in room air. All animals were allowed food and water ad libitum. Immediately upon termination of the exposure, renal biopsies were obtained either percutaneously under local anesthesia or at laparotomy under light ether anesthesia. Small pieces were fixed in cold veronal buffered osmium tetroxide, dehydrated and embedded in Epon 812 (ref 5). They were sectioned on an LKB Ultratome, stained with uranyl acetate, and examined with an RCA 3-G electron microscope. Examination was limited to cortical tissue.

RESULTS

Changes in the renal cortex were confined to the cells of the proximal convoluted tubules. Distal tubules and collecting ducts were normal in both control and experimental groups. Two types of changes were found: mitochondrial alteration (in all species studied), and an increase in number of a small cell organelle, described below (in dogs and monkeys only).

Mitochondrial Changes

The normal mitochondria have smooth profiles and an internal structure consisting of smooth and reasonably parallel cristae (figure 1). The most severe deviations from this pattern were found in the rats exposed to oxygen at 760 mm Hg. These showed (1) increase in size of mitochondria, with irregular outlines of mitochondrial membranes; (2) irregularity of mitochondrial cristae with disorientation of the usual parallel pattern; and (3) less dense mitochondrial matrix (figure 2).

Similar, but less severe, changes were found in rats exposed to 258 mm Hg for 3, 14, and 90 days. In 3-day rats, only very slight changes in the alignment of mitochondrial cristae were observed; in 14- and 90-day animals, all the changes described above were found, but to a much lesser degree. By 235 days, these changes had greatly diminished, and some animals in this group appeared entirely normal.

Dogs and monkeys exposed to 258 mm Hg for 14 and 90 days showed similar changes; they differed from rats in the following respects: (1) for similar exposures, changes were more severe in dogs and monkeys than in rats, (2) rather than irregularity in alignment of cristae, "smudging" and disappearance of cristae was the outstanding mitochondrial alteration in these species (figure 3). These changes also showed a partial or complete return to normal after 235 days.

Microbodies

Proximal tubule cells of normal dogs and monkeys contained an organelle not found in the rat. This organelle, somewhat smaller than a mitochondrion, consisted of a granular matrix similar to a mitochondrial matrix in density, limited by a single membrane. In many areas, this limiting membrane, along one or more sides of the organelle, was perfectly straight or only slightly curved, markedly thickened and deeply osmiophilic. When this occurred along more than one side of an organelle, strange geometric shapes were produced (figure 3). The term "geometric dense body" has, therefore, been suggested for this organelle by D. K. Roberts. Similar, or perhaps identical, organelles have been described in man as microbodies (ref 6).

The size and structure of these organelles was the same in the controls and the animals exposed to oxygen for 90 days. The number of these bodies, however, was markedly increased in the experimental group. The largest number was found in the 90-day (258 mm Hg) animals.

COMMENT

Since the function of the microbodies is unknown, it is too early to comment on the possible significance of their increase in number. On the other hand, the function of the mitochondria as the repository of the enzymes concerned with energy metabolism is well established. The proximal tubule is responsible for the resorption of approximately 80% of the water and electrolytes. Most of this resorption is by means of an energy requiring active pumping mechanism. This suggests that interference with these enzyme systems may have important physiologic consequences. Whether the morphologic alterations do in fact represent alterations in enzyme function will have to be determined by appropriate chemical and physiologic studies. However, the reversal to normal after prolonged exposure tends to support this hypothesis, as it may then be explained on basis of an enzyme adaptive mechanism.

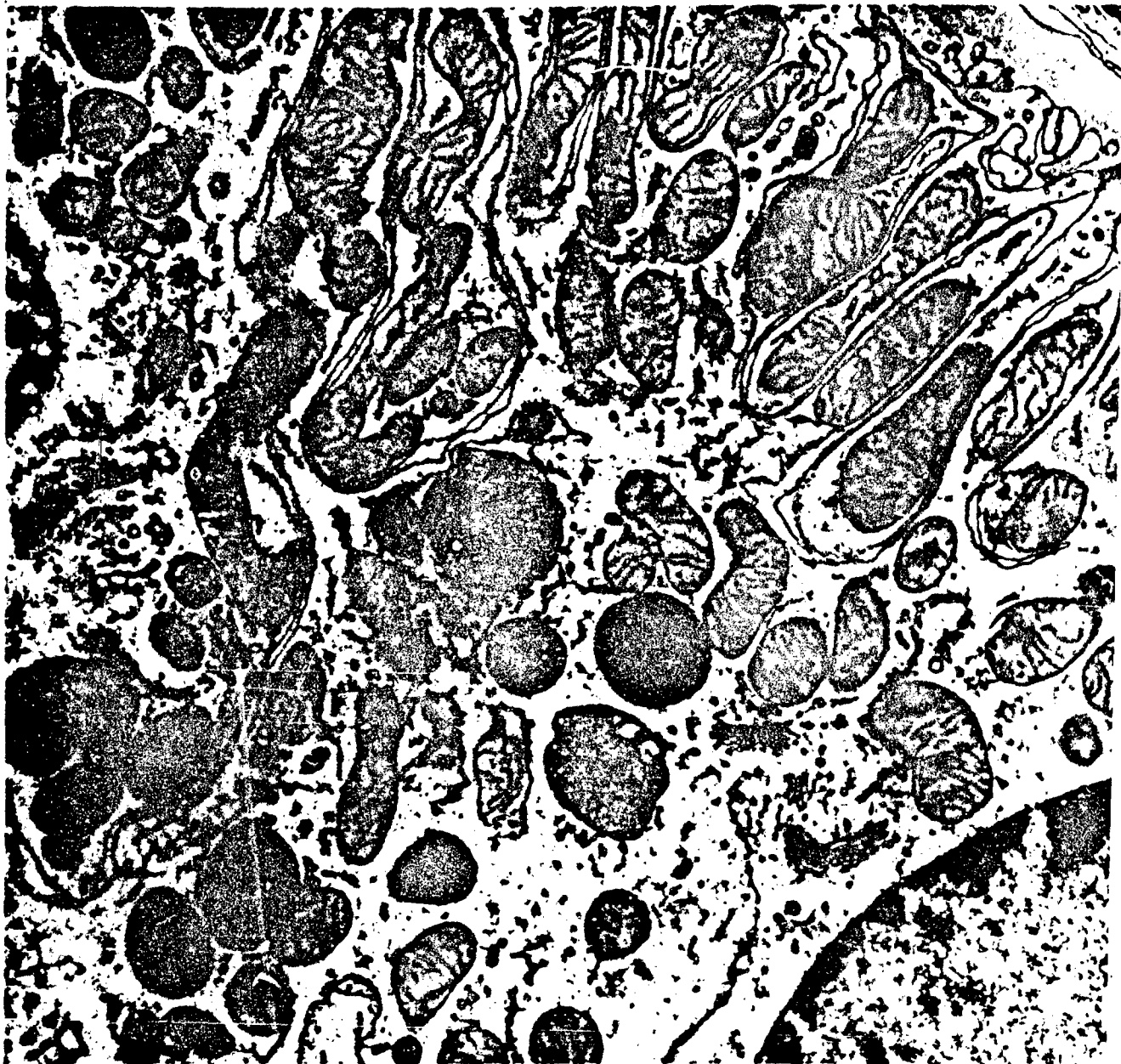

Figure 1. PROXIMAL TUBULE OF NORMAL MONKEY
Mitochondria have smooth profiles and normal cristae.
Electron Micrograph X 25,000



Figure 2. PROXIMAL TUBULE OF RAT, 1 DAY, OXYGEN AT
760 mm Hg
Mitochondria are enlarged and have irregular outlines
and cristae.
Electron Micrograph X 17,000



Figure 3. PROXIMAL TUBULE OF MONKEY, 3 MONTHS, OXYGEN
AT 258 mm Hg
Mitochondria have irregular outlines, and cristae are
smudged. Microbodies with geometric profiles are seen
between the mitochondria.
Electron Micrograph X 37,000

SUMMARY

Alterations in the proximal tubules of animals exposed to hyperoxic conditions consist of changes in the appearance of the mitochondria and an increase in number of a small cell organelle with geometric profiles. These changes tend to revert to normal on prolonged exposure.

ACKNOWLEDGMENT

This research was sponsored by the Aerospace Medical Research Laboratories under Contract AF 33(615)-1849.

REFERENCES

1. Schaffner, F.: 2nd Annual Conference on Atmospheric Contamination in Confined Spaces, 1966.
2. Kistler, G.: 2nd Annual Conference on Atmospheric Contamination in Confined Spaces, 1966.
3. Schaffner, F. and Felig, P.: J. Cell Biol. 27: 505, 1965.
4. Felig, P.: Aerospace Medicine 36: 858, 1965.
5. Luft, J. H.: J. Biophysic. and Biochem. Cytol. 9: 409, 1961.
6. Tisher, C. C., Bulger, R. E., and Trump, B. F.: Proceedings of the American Association of Pathologists and Bacteriologists. Am. J. Path. 48: 32, 1966.

DISCUSSION

DR. COULSTON: What we really need at this stage of the game is a volunteer for a liver and kidney biopsy. Then I think the answer would be very simple as to whether this is really going on in man.

DR. MAUTNER: This is not too difficult to do. I think it could be arranged.

FROM THE FLOOR: I think that those were terrific pictures of the distal tubule. You say that the mitochondria are all right. Although you didn't find any pathology, I was impressed by the fact that the nucleus was absolutely uniform. There was no chromatin which is a very rare phenomenon. Is this a coincidence?

DR. MAUTNER: I understand your question perfectly. I just don't agree with it. I've seen many, many nuclei in well-fixed electron microscopic material which were completely homogeneous, where there was no chromatin material apparent. This is one of the problems of the early electron microscopy. Now with the glutaraldehyde fixations we can see chromatin detail. This is not an indication that there is something wrong; this is simply characteristic of the fixation and embedding procedure that was used.

FROM THE FLOOR: I'm sorry, but in my laboratory when this occurs we suspect that something is wrong with the fixation.

DR. MAUTNER: When we don't have it we think something is wrong with the fixation.

DR. RIESEN (IIT Research Institute): I address this probably to you Dr. Mautner and also to Dr. Kistler and Dr. Schaffner. The electron micrographic changes are highly suggestive of the things that might be going on along the cristae. Have you people observed any changes in the particles that line up along the cristae that are related to oxygen exposure?

DR. MAUTNER: I can answer regarding the kidney. Since the cristae usually disappear there is nothing along them. The matrix takes over a larger space, sometimes involving almost the entire mitochondrion. You simply see no cristae structure whatsoever.

DR. SCHAFFNER: I'd like to answer Dr. Riesen on this point because I think it's probably going to be an extension of work that may have to be done by all of us. By the way, this can't be done in tissue sections. It has to be done in isolated mitochondria with negative staining techniques. In the search for the elementary particles of the mitochondrial cristae, the structural alterations in them are going to be key factors and we're going to start looking for correlations with your biochemical data.

DR. COULSTON: I should remark that we've seen similar changes in the kidney with a pesticide known as "Carbamate 7", where the only changes in the kidney are vacuolization in the proximal convoluted tubule, a very similar effect on mitochondria. This again, I think, emphasizes that just taking oxygen in by the

lung is not the whole story, that organs are involved all through the body, and I think this means that we have to be very careful of what we say about what goes on here.

DR. ROTH (Lovelace Foundation): Has anyone looked at the urine of these animals for protein casts or electrolyte changes?

CAPT. KAPLAN (Toxic Hazards Division): For the most part the urine samples are completely normal.

DR. THOMAS: Are these studies not at all supported by routine light microscopy?

DR. MAUTNER: You couldn't see these changes in light microscopy.

DR. THOMAS: But you certainly could see protein casts.

DR. COULSTON: With the Carbamate I described you can see some changes with the light microscope. You know there's something there. It's what the pathologists would call "cloudy swelling". There may be a little vacuolization but you can't really see it until you come down to about 20 angstroms resolution with the electron microscope and then you really begin to see it.

CELLULAR BIOCHEMISTRY OF OXYGEN TOXICITY

Willis H. Riesen, Ph.D.

IIT Research Institute
Chicago, Illinois

INTRODUCTION

The work I am reporting was performed during the past year in the general area of oxygen toxicology of space cabin atmospheres. This work specifically pertained to biochemical aspects of oxygen toxicity at a cellular and a mitochondrial level. It was performed at the Aerospace Medical Research Laboratories by IIT Research Institute personnel in cooperation with Air Force personnel. The work was a continuation of previous studies conducted by Captain P. Felig, USAF, MC, and Major W. L. Lee, USAF, MC.

The electron microscopic investigations presented by Dr. G. Kistler, Dr. F. Schaffner, and Dr. W. Mautner suggest that the toxic cellular mechanism might reside in the mitochondria. The extensive studies of Dr. E. R. Weibel and Dr. Felig showed mitochondrial structural changes, including cristae degeneration and possible alterations of the redox state of the pyridine nucleotides. The latter was suggested in the investigation of factors that modify an organism's response to the noxious effect of oxygen. Some of the pioneering work performed by Dr. Felig at the Aerospace Medical Research Laboratories is next summarized.

Rats were exposed in the closed system environment chamber (Felig-Lee) to pure (98.5%) oxygen at a pressure of 13 inches of water above ambient (ref 1). The rats were treated with various agents by daily intraperitoneal injection in the chamber. Survival after four days is shown in table I.

TABLE I

SURVIVAL OF RATS EXPOSED TO 98 PER CENT OXYGEN FOR FOUR DAYS AND TREATED WITH VARIOUS AGENTS

<u>Agent</u>	<u>No. of rats</u>	<u>Survival rate (%)</u>
Saline	16	12.5
THAM	10	10.0
Bicarbonate	12	16.6
Acetate	10	20.0
Pyruvate	10	20.0
Lactate	17	64.7*

*P (as compared to saline) < 0.01

Lactate administration increased the survival from 12.5 to 64.7%, while THAM, bicarbonate, acetate, and pyruvate had insignificant effects in comparison with the saline control. The mean survival time was increased also by lactate (table II) but not by the other agents. The saline-treated lungs were dark red and rubbery and sank in formalin. The lactate-treated lungs were normal in appearance.

TABLE II

MEAN SURVIVAL TIME OF RATS EXPOSED TO 98 PER CENT OXYGEN

<u>Agent</u>	<u>Survival time (days)</u> Mean \pm S. E.
Saline	5.6 \pm 1.6
THAM	3.3 \pm 0.2
Bicarbonate	5.3 \pm 1.8
Acetate	7.6 \pm 2.9
Pyruvate	7.7 \pm 2.9
Lactate	11.4 \pm 1.7*

* P (as compared to saline) < 0.025

This study showed that pH elevation probably is not the mechanism of lactate protection. Dr. Felig proposed that lactate, in couple with the pyridine nucleotides generated DPNH (NADH), which may be depleted with exposure to excess oxygen. If the substance tested, only lactate can uniquely generate DPNH; the other substances, such as acetate and pyruvate, have alternate metabolic pathways (figure 1). This hypothesis is very attractive and is suggested also by some of the findings of Dr. B. Chance (ref 2).

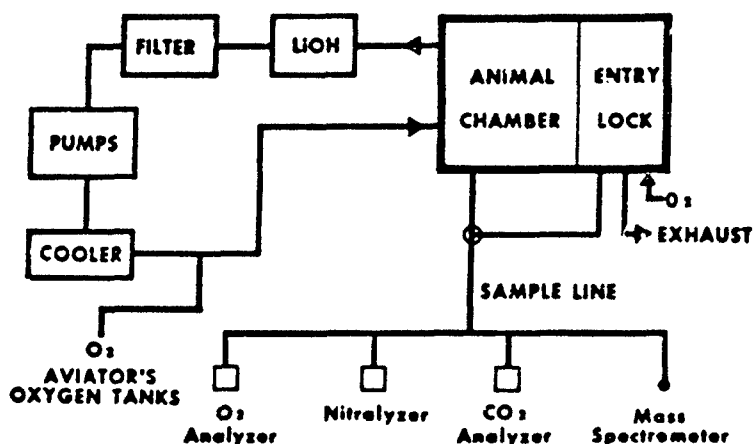

Figure 1. BLOCK DIAGRAM OF CHAMBER FACILITIES. Direction of flow of atmosphere is indicated by arrows.

EXPERIMENTAL

The work carried out by IIT Research Institute continued the investigation by directly examining some of the metabolic processes thought to be affected by exposure of experimental animals to pure oxygen environments at different pressures. Tissues were examined at a subcellular (mitochondrial) level for changes in respiratory indices and activities of selected enzyme systems.

The initial phase of the project consisted of adapting biochemical assay techniques to the specific requirements of the study. Normal values were obtained from the various biochemical analyses on approximately 24 rats, and the animal variations were computed for each analysis. Sample variation was determined by analyzing replicates from one pooled or intact tissue source. Generally, animal variation was greater than that of replicate samples from the same tissue.

The major portion of the program consisted of exposure of rats to atmospheres of pure oxygen at 760 mm Hg in the Felig-Lee environmental chamber or in the same atmosphere at 750-760 mm Hg in the Thomas Dome. The results of these analyses were extensively analyzed statistically and will be presented largely in graphic form. The total sets of chambers, animals, and atmospheres are shown in table III. The experiments with dogs and monkeys were preliminary and will not be presented here.

TABLE III

ENVIRONMENTAL CHAMBERS, ATMOSPHERES, AND EXPERIMENTAL ANIMALS

<u>Chambers</u>	<u>Atmospheres</u>	<u>Animals</u>
Felig-Lee	98.5% oxygen at 760 mm Hg	Rats (Sprague-Dawley, Harlan)
Thomas Dome	98.5% oxygen at 750-760 mm Hg	Rats (Sprague-Dawley, Harlan)
	98.5% oxygen at 258 mm Hg	Dogs (Beagle)
		Monkeys (<u>Macaca mulata</u>)

The times of exposure used for each oxygen pressure in the experiments are shown in table IV. The major limitation in time at a pressure of 1 atm is the period of lethality, which can be as short as 3 to 5 days with rats. While adaption can occur at this pressure with certain strains of rats, morphological changes have been detectable in studies at Aerospace Medical Research Laboratories at 6 to 24 hours.

TABLE IV
TIMES OF EXPOSURE

Oxygen Pressure, mm Hg	Times of Exposure, hours						
750-760	6	24	48	72	96		
258		24		72		168	336 236 (days)

The biochemical analyses are shown in table V. They were chosen to reflect amental changes in intracellular metabolism and energy utilization. The es selected for analysis included whole liver and lung, liver and lung mitochon-, and arterial blood.

TABLE V
TISSUES AND BIOCHEMICAL ANALYSES

imal roup	Tissue	Biochemical Analyses
U	Liver mitochondria	Q_{O_2N} and P/O (α -ketoglutarate substrate) LDH total activity and isoenzymes
	Lung mitochondria	Q_{O_2N} (succinate substrate) LDH total activity and isoenzymes
V	Whole liver	NAD, NADH, and NAD/NADH
	Whole lung	NAD, NADH, and NAD/NADH
W	Arterial blood	Lactate, pyruvate, and lactate/pyruvate

Since the prime interest was the mechanism of tissue respiration, particular- idative phosphorylation, mitochondria were fractionated from liver and lung. methods are essentially those of Dr. H. A. Lardy, Institute for Enzyme Re- ch, University of Wisconsin*. The technique for mitochondrial fractionation is n schematically in figure 2. Although this procedure was used for lung, at the ent time it is considerably modified by osmotic and cation control specific for organ. Lung presented particular difficulty because the mitochondrial yield uch lower, and coupled phosphorylation was more difficult to demonstrate. e tightly coupled oxidative phosphorylation with liver mitochondria were ly obtained by us by using NAD-linked substrates such as α -ketoglutarate, only n consumption without phosphorylation could be measured with lung, by using i-linked succinate as the substrate.

ional Communication

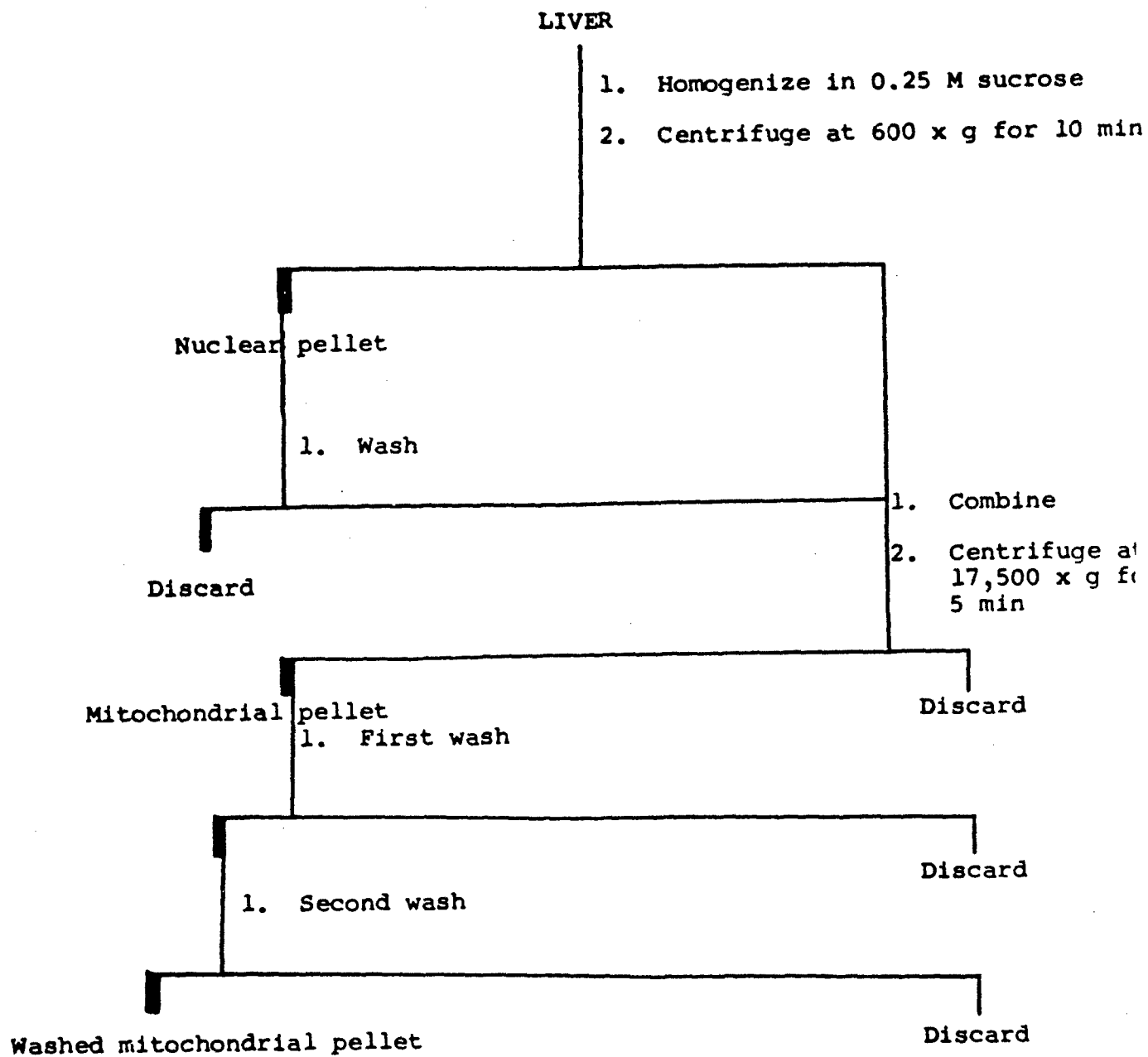

Figure 2. FLOW DIAGRAM OF PROCEDURE FOR LIVER MITOCHONDRIAL FRACTIONATION

The total lactic dehydrogenase (LDH) activity in both mitochondrial preparations was measured. Also, the distribution of isoenzymes was determined by electrophoresis on agar gel. It should be pointed out that the role of LDH in mitochondria is presently not fully elucidated. Generally, tissue homogenates or serum are used for this analysis. Mitochondrial LDH probably reflects to some degree the LDH of the homogenate. Our results showed little change in LDH isoenzyme pattern with oxygen exposure.

The ox-redox state of the tissue was determined by measuring NAD, NADH, and NAD/NADH. This analysis requires special techniques of tissue removal, namely, direct freezing of the tissue in Freon liquified in liquid nitrogen, extraction in acidic or alkaline media, measurement of the nucleotide by an enzyme cycling method and final reading in a spectrophotometer. The technique is based upon recently developed procedures of Dr. D. Lowry (ref 3) and Drs. Helen B. Burch and Patricia Von Dippe (ref 4) at the Washington University School of Medicine, St. Louis. It is crucial that not more than a few seconds transpire after tissue ischemia to prevent anomolous values for NADH.

To measure the systemic ox-redox state of the animal, lactate and pyruvate were analyzed in arterial blood. Both individual values and ratios were determined. These metabolites were analyzed enzymatically with LDH in a spectrophotometer by using the method of N. Kransnow et al (ref 5).

Three different animal groups were generally required when all the analyses were made because of specific methods for anesthesia and tissue removal. In group U, the animals were killed by a blow on the head and were immediately decapitated. After drainage of excess blood for a few seconds, liver and lung were rapidly removed for homogenization and mitochondrial fractionation. Animals of group V were anesthetized with ether, and simultaneous thoracic and abdominal incisions were made with minimal blood vessel damage for tissue freezing. In animal group W, arterial blood was drawn from the femoral artery under ether anesthesia.

A summary of the experimental runs is shown in table VI. The major group of runs, 1 to 6, consisted of rats exposed to oxygen at 1 atm in both the Thomas Dome and the Felig-Lee chamber. Comparable experiments with rats at 258 mm Hg in the Thomas Dome were runs 10, 12, and 13. Large-animal experiments in the Thomas Dome were runs 7, 8, 9, and 11. Run 15 consisted of a test of direct tissue freezing in the chamber rather than outside under sodium pentobarbital anesthesia, for the analysis of NAD and NADH.

Several distinctions in connection with experimental design should be pointed out. Values for biochemical analyses obtained from animals breathing ambient air outside the chamber independent of any experimental run are designated "normal". Those for animals breathing air outside the chamber but drawn randomly from the same lot as that of experimental animals and analyzed at the same time as experimental animals are designated "control". Animals exposed to oxygen for various periods of time and analyzed with corresponding controls are designated "experimental". Adaptation observed during exposure to oxygen in experimental animals should be distinguished from recovery in air after oxygen exposure.

TABLE VI

SUMMARIZED COMPILATION OF EXPERIMENTAL RUNS

Run	Oxygen Pressure, mm Hg	Animal	Chamber	Maximal Exposure Interval	Biochemical Analysis ^d
N-1 ^a		Rat	None		U, V, W
1, 2 ^c	760	Rat	Felig-Lee	72 hr	U, V, W
3, 4	750	Rat,	Thomas	96 hr	U, V, W
5, 6	760	Rat	Felig-Lee	96 hr	U, V, W
7 ^{c, b}	750	Monkey	Thomas	170 hr	V
8 ^{c, b}	258	Monkey	Thomas	236 days	U, V, W
9 ^b	258	Dog	Thomas	236 days	U, V
10 ^c	258	Rat	Thomas	236 days	U, V
11 ^b	258	Monkey	Thomas	72 hr	U, V
12	258	Rat	Thomas	336 hr	U, V
13	258	Rat	Thomas	168 hr	U, V
14	750	Rat	Thomas	72 hr	U, V
15 ^b	760	Rat	Felig-Lee	96 hr	V
N-2 ^{a, b}		Rat	None		

^a"Normal" animals in air at ground-level pressure

^bModified procedures for tissue removal

^cIncluded in air recovery experiment

^d"U" designates liver mitochondrial Q_{O_2N} , P/O, and LDH and lung mitochondrial Q_{O_2N} and LDH;

"V" designates liver NAD/NADH and lung NAD/NADH; "W" designates arterial blood lactate/pyruvate.

Morphological studies were done simultaneously with the biochemical studies to enable direct comparison with and to determine the phasing of morphological changes demonstrated in earlier studies. The morphological changes associated with these studies are further described by Dr. Schaffner.

RESULTS

Exposure of Rats to Oxygen at 1 Atm

In runs 1 and 2, rats were exposed to oxygen in the Felig-Lee chamber for 6, 24, 48, and 72 hours; only one set of animals breathing air outside the chamber was used for control and was analyzed in the interval between runs 1 and 2. Animals were also removed after 72 hours for recovery in air for 3 to 10 days. In runs 3 and 4, rats were exposed to pure oxygen in the Thomas Dome for 24, 48, 72, and 96 hours; control rats breathing air were used for analysis at the same time the experimental animals were used. Runs 5 and 6 were similar to runs 3 and 4, except the Felig-Lee chamber was used. All the biochemical analyses were carried out. In experimental subgroups (for each period of exposure and each analytical animal group), three to four animals each were used. In control subgroups, two animals each were used.

Since runs 3, 4, 5, and 6 were symmetrically designed with respect to controls and time of exposure, they were analyzed for variance as one set. Runs 1 and 2 could not be included since control animals were not separated with respect to time of exposure of experimental animals.

Liver Mitochondrial Q_{O_2N} and P/O Ratios (Animal Group U)

An analysis of variance of the liver mitochondrial Q_{O_2N} values showed no significance with respect to the effect of oxygen.

The mean differences between the experimental P/O ratios and the air control ratios for runs 1 to 6 are shown in figure 3. The control pertinent to each run, namely, the joint control for runs 1 and 2 and the separate controls for each exposure period in runs 3, 4, 5, and 6, are used as the zero reference points. In runs 1, 2, 5, and 6, all differential values are negative and thus show a reduction in P/O ratio due to oxygen exposure. Reduction as a function of time is suggested, but is not uniform in these runs. In runs 3 and 4, the differential plots show trends that tend to parallel, but the reduction in ratio is less than that in the other runs. Both a difference in the pattern and in the extent of change by the two environmental chambers are suggested.

Runs 1 and 2 showed nearly complete recovery to normal values when the animals were removed from the chamber after 72 hr and exposed to air. No significant difference is seen between 3 days or 10 days of recovery.

A summary of an analysis of variance for P/O ratios for runs 5 and 6 is shown in table VII. The analysis was done on the basis of log P/O ratio. The results showed significant control-versus-oxygen effect. The importance of the simultaneous controls is borne out by the size of the R, T, and R x T effects. A more dramatic

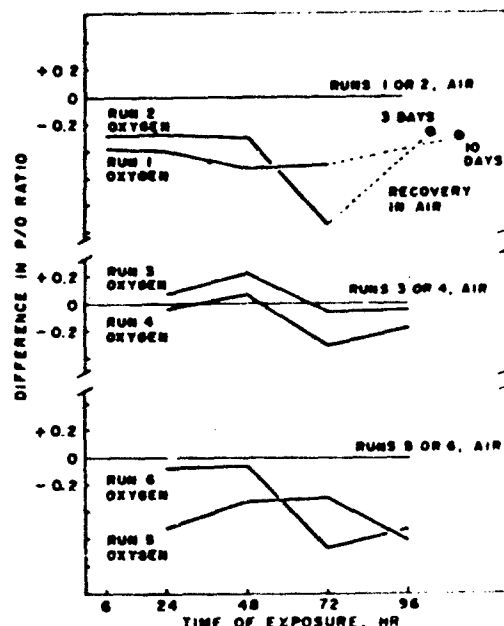

Figure 3. COMPARISON BY INDIVIDUAL RUN OF CHANGE IN LIVER MITOCHONDRIAL P/O RATIOS FOR RATS EXPOSED TO 1 ATM OF OXYGEN WITH THAT FOR RATS EXPOSED TO AMBIENT AIR.

significance of the effect of oxygen treatment can be shown by considering only terminal values, i. e., those at the end of the exposure period.

TABLE VII

ANALYSIS OF VARIANCE OF LIVER MITOCHONDRIAL P/O RATIOS FROM RUNS 5 AND 6

Effect	d. f.	Sum of Squares	Mean Square	F	P
Run, R	1	0.00673	0.00673	2.246	n. s.
Time, T	3	0.04627	0.01542	5.146	0.99
Oxygen, O	1	0.02448	0.02448	8.170	0.99
R x T	3	0.02566	0.00855	2.853	0.93
R x O	1	0.00063	0.00063	0.210	n. s.
T x O	3	0.01094	0.00365	1.218	n. s.
R x T x O	3	0.00822	0.00274	0.914	n. s.
Error	20	0.05993	0.00300		
Total	35	0.18286			

Lung Mitochondrial Q_{O_2N} (Animal Group V)

An analysis of the variance of the lung mitochondrial Q_{O_2N} values showed no significance with respect to the effect of oxygen. P/O ratios were not feasible with lung mitochondria.

Liver Mitochondrial LDH (Animal Group V)

The analyses for LDH activities with liver mitochondria show different trends in the three different pairs of experimental runs. In runs 1 and 2, shown in figure 4, considerable elevation in the experimental values is seen with increasing duration of exposure to oxygen. Animals removed after 72 hours in oxygen and subsequently 3 or 10 days in air show nearly a complete return to the control values. These control animals, however, were not phased with the experimental animals with respect to time of exposure.

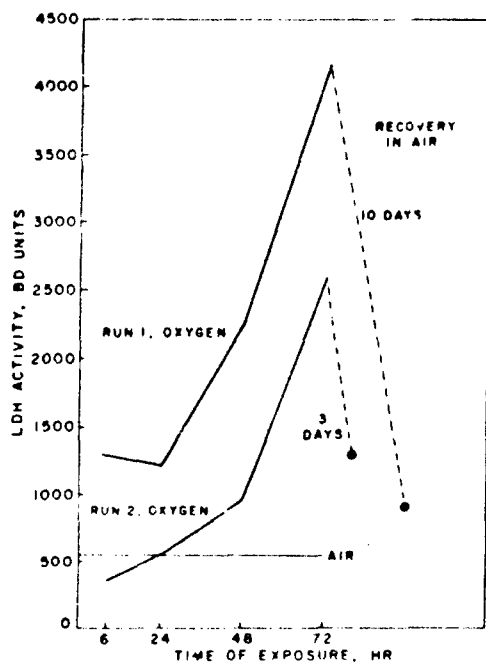

Figure 4. COMPARISON IN RUNS 1 AND 2 OF CHANGE IN LIVER MITOCHONDRIAL LDH ACTIVITY FOR RATS EXPOSED TO 1 ATM OF OXYGEN WITH THAT FOR RATS EXPOSED TO AMBIENT AIR.

In runs 3 and 4, the values for the experimental animals were little different from those of the control animals and did not vary with time of exposure. All mean values ranged from approximately 1200 to 2000 units. In run 5, a minimum value in both experimental and control animals was found at 48 hours; in run 6, a maximum value in both experimental and control animals was found at 72 hours. Control versus experimental difference plots for runs 3, 4, 5, and 6 (figure 5) showed a slight net elevation of mitochondrial LDH activity with oxygen exposure.

Lung Mitochondrial LDH (Animal Group V)

The lung mitochondrial LDH showed trends similar to those of liver mitochondria although the scatter of data was somewhat greater.

Weight Change (Animal Groups U, V, and W)

In addition to these changes in biochemical indices, change in animal weight during exposure to oxygen or air was observed. The weight index measures the overall anabolic or catabolic state of the animal and hence is a general physiological

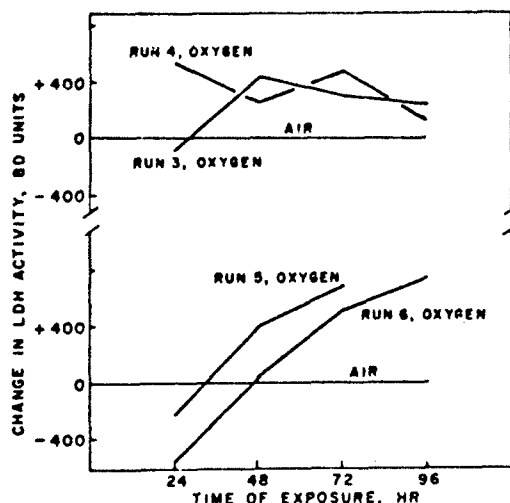

Figure 5. COMPARISON IN RUNS 3, 4, 5, AND 6 OF CHANGE IN LIVER MITOCHONDRIAL LDH ACTIVITY FOR RATS EXPOSED TO 1 ATM OF OXYGEN WITH THAT FOR RATS EXPOSED TO AMBIENT AIR.

index. The percent weight changes during exposure to oxygen in comparison with percent weight changes in air in runs 3, 4, 5, and 6 are summarized in table VIII.

TABLE VIII

PERCENT WEIGHT CHANGE OF RATS DURING EXPOSURE TO OXYGEN IN COMPARISON TO AIR AT ONE ATMOSPHERE OF PRESSURE

Run	Chamber	24	48	72	96	Mean
3	Thomas	+1.1	-3.0	-11.3	-20.6	- 8.45
4	Thomas	-7.9	+1.0	-20.4	-26.0	-13.32
5	Felig-Lee	-6.3	-7.4	-10.2	-20.9	-11.20
6	Felig-Lee	+5.5	-4.4	-26.3	-33.9	-14.78
Mean Weight Change		-2.0	-3.5	-17.1	-25.4	-12.00

Plus (+) sign designates increase in weight due to oxygen exposure. Minus (-) sign designates decrease in weight due to oxygen exposure.

The results generally show a reduction in rate of weight gain (including weight loss) during oxygen exposure in comparison with the rate of weight gain during air exposure. The weight-change index showed similar physiological impairment as a result of oxygen exposure in either the Thomas Dome (runs 3 and 4) or the Felig-Lee chamber (runs 5 and 6).

Summary Graphs and Table of Significant Indices (Runs 3 to 6)

The data trends for animals exposed to 1 atm of oxygen compared with the data trends in control animals tested in parallel are shown graphically and in table

form. The analysis of variance made detection of relatively small differences possible because of the large body of data.

The next three figures show the trends and the confidence limits for liver mitochondria for the P/O ratio, the LDH, and the animal weight change compared with the parallel control groups in runs 3, 4, 5, and 6. The confidence limits for the control groups were larger because fewer control animals than experimental animals were used. The confidence limits were calculated on the basis of the number of samples used at each time period.

The slight rise in P/O ratio at 48 hours (figure 6) may not be significant. The difference at 72 and 96 hours, however, was 10% or approximately 0.3 unit; the 95% confidence interval for experimental P/O ratios at these time periods was completely outside that for control P/O ratios. This analysis pertained to runs in both environmental chambers.

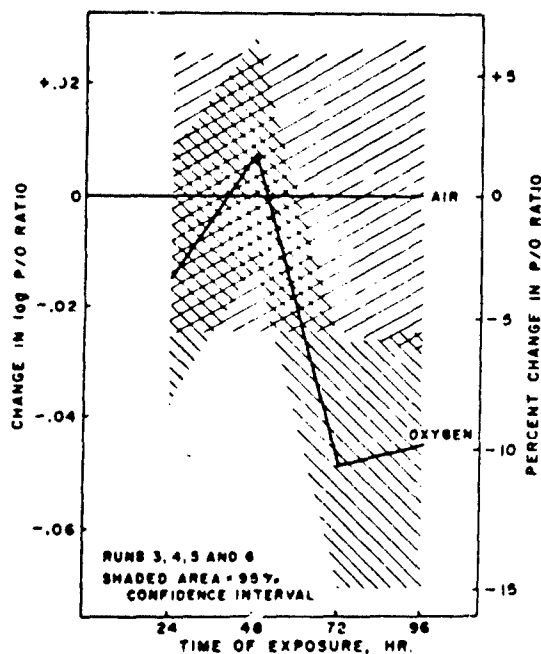

Figure 6. STATISTICAL COMPARISON OF CHANGE IN LIVER MITOCHONDRIAL P/O RATIO FOR RATS EXPOSED TO 1 ATM OF OXYGEN WITH THAT FOR RATS EXPOSED TO AMBIENT AIR.

No significant rise in liver mitochondrial LDH activity (figure 7) was seen until 48 hours; from 48 hours through 96 hours, the 95% confidence interval for experimental animals was outside that for control animals.

The overall change in weight is shown in figure 8. While significant change was apparent at 24 or 48 hours of exposure, after 96 hours the oxygen-exposed animals showed a loss approximately four times greater than the 95% confidence limit for control animals. Similar analyses showed largely insignificant trends for liver or lung NAD/NADH or arterial blood lactate/pyruvate.

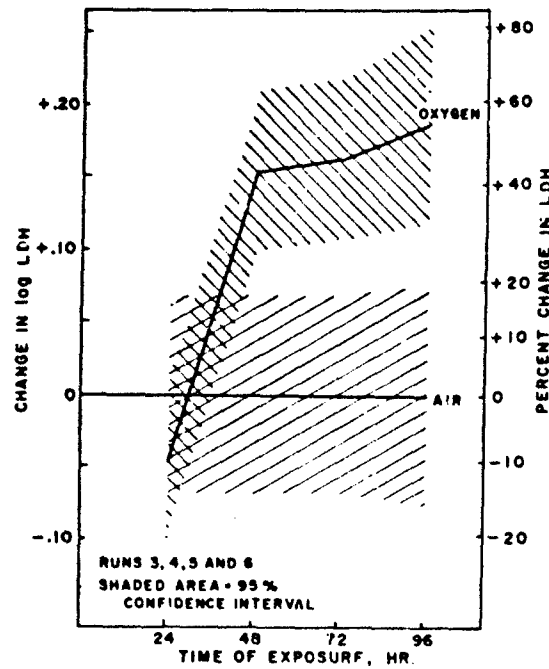

Figure 7. STATISTICAL COMPARISON OF CHANGE IN LIVER MITOCHONDRIAL LDH FOR RATS EXPOSED TO 1 ATM OF OXYGEN WITH THAT OF RATS EXPOSED TO AMBIENT AIR.

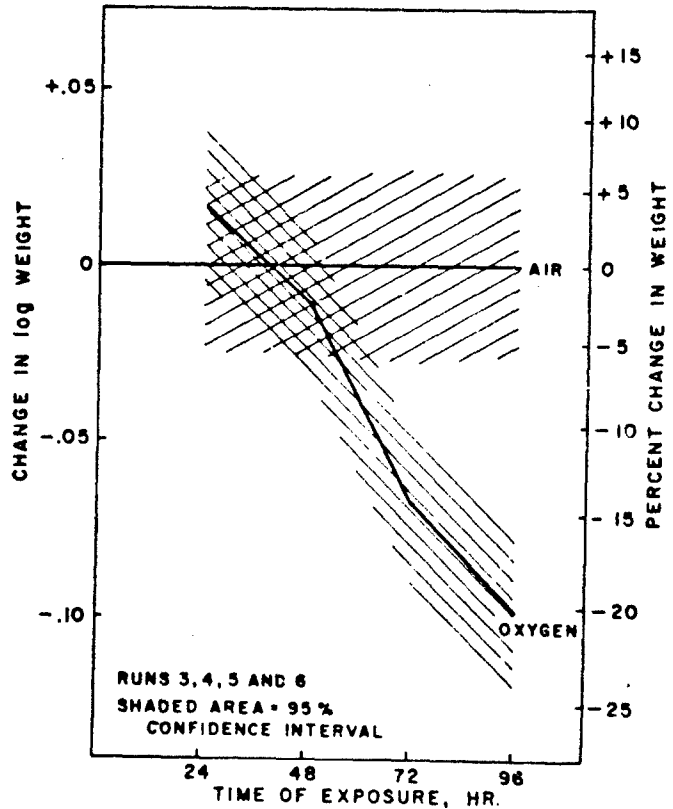

Figure 8. STATISTICAL COMPARISON OF CHANGE IN WEIGHT FOR RATS EXPOSED TO 1 ATM OF OXYGEN WITH THAT FOR RATS EXPOSED TO AMBIENT AIR.

Table IX shows the results of tests of significance for each of the variables analyzed. The T x O interaction determined whether a significant pattern of change in the effects of oxygen exposure with respect to time occurred. The R x O interaction determined whether the level of the oxygen effect was reproducible from run to run. The oxygen effect was then tested with respect to run-to-run variation. Since only four runs and two different chambers were used in the analysis, run-to-run variation cannot be firmly established. The objective was to detect nonrandom oxygen effects and effects changing with respect to time.

Variation in response from run to run seems inevitable. LDH in liver had significant variation from run to run, but P/O ratio did not as significantly vary from run to run. The weight change was highly significant. Run-to-run variation in liver NAD may have been due to an unknown anomaly.

Regression-on-Exposure Index

The coefficients of this index could be considerably altered as additional data are analyzed. However, both P/O ratio and weight change have considerable independent information (figure 9, 10) and for experiments of which these runs are typical, the regression-on-exposure index is efficient.

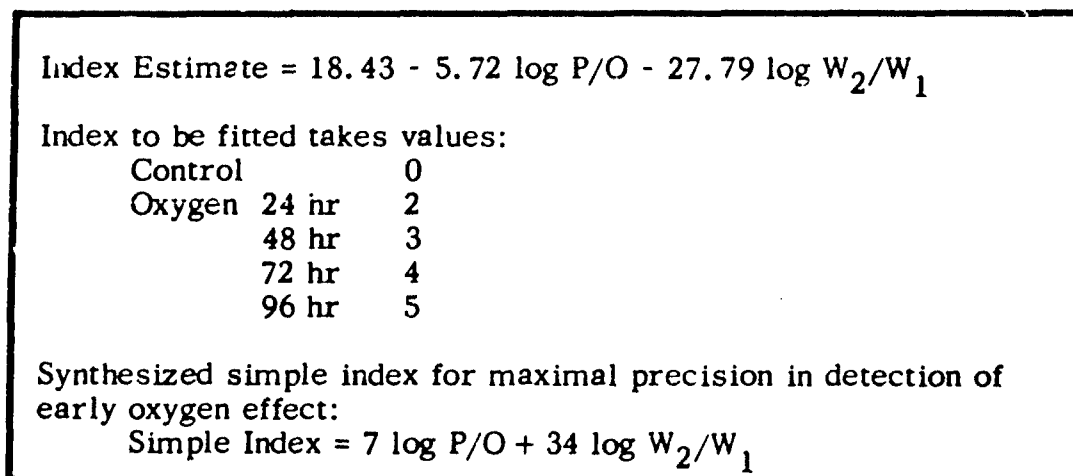

Figure 9. REGRESSION ON EXPOSURE INDEX

TABLE IX

SUMMARY OF ANALYSES OF VARIANCE FOR EXPERIMENTAL RUNS
(3, 4, 5, AND 6) IN WHICH RATS WERE EXPOSED TO 1 ATMOSPHERE OF OXYGEN

No.	Variable	Significance of Oxygen Effect	Significance of Time x Oxygen	Significance of Run x Oxygen	Proven Reproducibility of Oxygen Effect
1	Q _{O₂} N	0.995	0.95	0.95	0.80
2	P/O	n. s.	n. s.	n. s.	n. s.
3	LDH, liver mitochondria	0.9995	0.995	n. s.	0.999
4	LDH, lung mitochondria	n. s.	0.90	0.995	n. s.
5	NADH, liver	n. s.	n. s.	n. s.	n. s.
6	NAD, liver	0.9995	n. s.	0.9995	n. s.
7	NAD/NADH, liver	n. s.	n. s.	n. s.	n. s.
8	Lactate, blood	0.98	n. s.	0.80	0.80
9	Pyruvate, blood	0.95	n. s.	0.94	0.80
10	L/P, blood	n. s.	n. s.	n. s.	n. s.
11	Weight Loss	0.9995	0.9995	n. s.	0.999



Figure 10. PARTITION OF THE SUMS OF SQUARES SHOWING THE COMMON PARTS OF VARIANCE RELATED TO AN OXYGEN EXPOSURE INDEX

Animals Exposed to Oxygen at 1/3 atm

The objective of the experimental exposures of animals to 1/3 atm of pure oxygen was to determine whether biochemical changes could be detected in animals exposed to atmospheres simulating those of manned space flight. If the mechanism of any chronic oxygen impairment at 1/3 atm is similar to the acute changes at 1 atm, the same indices should be applicable at the reduced pressure.

Rats have been exposed in the Thomas Dome for as long as 236 days. Figure 11 shows an analysis of the data by using the overall exposure index ($\log W_2/W_1 + 1/4 \log P/O$) at 1 atm. An upward trend, signifying "beneficial" effects, is seen at 7 days. Between 2 weeks and 8 months, the index shows equilibration to a normal range. It is of interest that a $\log P/O$ plotted in the same manner shows an almost identical pattern. Additional experiments are required to determine the significance of this unusual trend.

Dogs were exposed to oxygen at 258 mm Hg in the Thomas Dome for 236 days. Liver samples were removed surgically from live pentobarbital-anesthetized dogs by meningeal needle biopsy. P/O and $NAD/NADH$ values for the oxygen-treated animals were not significantly different from those for air controls (table X).

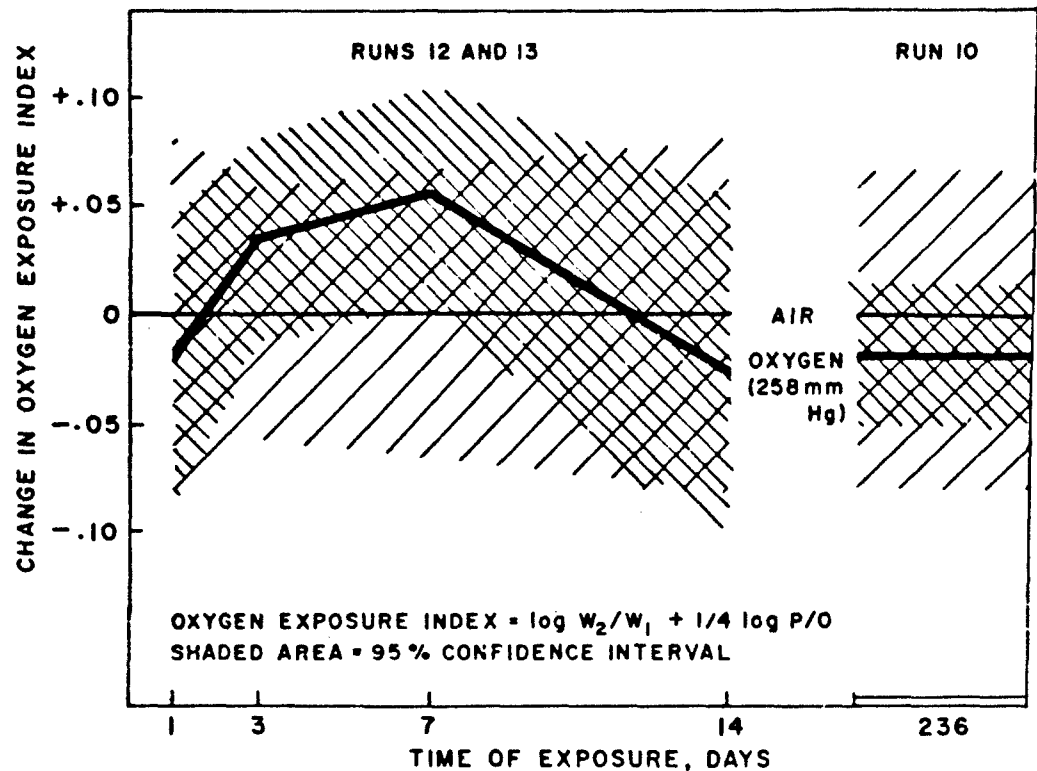

Figure 11. CHANGE IN OXYGEN EXPOSURE INDEX OF RATS BREATHING PURE OXYGEN AT 258 mm Hg PRESSURE IN COMPARIS TO RATS EXPOSED TO AMBIENT AIR.

TABLE X

LIVER MITOCHONDRIAL P/O RATIOS AND LIVER NAD/NADH RATIOS OF DOGS EXPOSED IN THE THOMAS DOME TO OXYGEN AT 258 MM HG (RUN 8)

Condition	P/O	NAD/NADH
Air control	2.69	15.3
	2.09, 2.41	7.8
	Avg. 2.47	11.55
Oxygen, 236 days	2.16, 2.25	5.5
	2.16, 2.47	10.6
	Avg. 2.26	8.05

Monkeys were exposed to oxygen at 258 mm Hg in the Thomas Dome for many as 236 days, with a 40-day air recovery. Liver tissue excision for P/O ratio and nucleotide analyses were the same as described for dogs. The results (table XI) showed P/O ratios in the normal range similar to those for rat liver. The NAD/NADH ratios ranged from 5.5 to 6.2, comprising a narrow range showing no oxygen effect. Acceptable values for normal rat liver are in the range of 8 to 10. Analyses of the recovery animals showed similar results. The 72-hour results show the need for additional work in improving methodology and accumulation of large samples of data.

TABLE XI

LIVER MITOCHONDRIAL P/O RATIOS AND LIVER NAD/NADH RATIOS
OF MONKEYS EXPOSED IN THE THOMAS DOME TO OXYGEN AT 258 MM HG

	<u>P/O</u>	<u>NAD/NADH</u>
<u>Run 9</u>		
Air control, 236 days	3.23, 2.92 2.43, 2.55 Avg. 2.78	5.5 5.8 Avg. 5.65
Oxygen, 236 days	3.67, 3.28 2.78, 2.78 Avg. 3.13	6.2 5.9 Avg. 6.05
Oxygen, 236 days + air, 40 days	3.74, 3.43 3.91 Avg. 3.78	5.1 4.9 Avg. 5.0
<u>Run 11</u>		
Oxygen, 72 hr	2.39, 2.34 * Avg. 2.37	20.9 5.3

*Insufficient sample was available.

CONCLUSIONS AND DISCUSSION

Exposure of animals to pure oxygen at 1 atm of pressure produces biochemical changes that are highly significant. In rats, liver mitochondrial P/O ratios show a significant uncoupling of oxidative phosphorylation. Such uncoupling is rarely found in the clinically diseased state of humans. Hence, the reduction in ratio observed in our experiments has considerable importance. The statistical demonstration of even a slight reduction during any time during exposure to animals or humans to oxygen at 1/3 atm should be carefully investigated. More sensitive methods of measuring uncoupling of phosphorylation are available and should be applied.

Since lung is the target organ, a study of oxidative phosphorylation in this tissue will be of considerable interest. Since measurements of respiratory rates and oxidative phosphorylation with substrates not linked to pyridine nucleotides do not appear as pertinent for studies of oxygen toxicity, succinate will be superseded in future work with other substrates. Modified procedures will be used for the isolation of lung mitochondria.

While the changes in LDH activity in liver and lung mitochondria were significant, they should be applied to tissue homogenates and serum. We consider it quite unusual that altered patterns in LDH isoenzyme distribution were not seen as a result

of oxygen exposure. Altered patterns have been observed in many diseased states and in exposure of animals to gamma irradiation, a stress that many investigators think has similar mechanisms to that of oxygen toxicity.

Our findings with regard to NAD and NADH were, in a sense, surprising in view of the extreme sensitivity of this coenzyme redox couple to anoxic and hyperoxic exposure demonstrated by Chance and coworkers. We believe that our methodology for liver is quite good and should have revealed changes had they occurred. Nevertheless, the analytical method used will be reevaluated for greater precision and sensitivity. Lung, for example, has an extremely low content of NADH. Experiments designed to test sampling in the chamber by biopsy or rapid tissue removal under anesthesia are in progress. The period that normally ensues after removal of animals from the chamber prior to sacrifice is generally short; changes during this period, however, are possible.

Among the questions that should be asked with regard to the protective effect of lactate is whether its administration can produce enough NADH inside a mitochondrion. Since nucleotides do not generally enter the mitochondrion, extramitochondrial NADH would be required to transmit the effect unless lactate were to pass the mitochondrial membrane. The finding by Sanders that succinate is protective against hyperbaric oxygen suggests bypass of the pyridine nucleotide system. Clearly, additional effort toward finding an ideal protective substance is required. The problem is difficult; it now appears that parenteral administration of any substance must have its effect in the mitochondrion while the substance itself probably does not enter this structure at all.

The lack of any large changes in blood lactate, pyruvate, or lactate/pyruvate ratio is not too surprising. The effects of oxygen are subtle and most likely confined to mechanisms of energy transfer in oxidative, rather than anaerobic, metabolism. However, a significant rise in either lactate or pyruvate, even independent of change in ratio, does reveal significant changes in anaerobic pathways.

The investigation of the effects of oxygen exposure upon specific enzyme systems will be continued. Those enzymic systems linked to NAD or NADH will be emphasized. The best place to look for the direct effect of oxygen, however, appears to be the mitochondrial electron-transport system. It is here that most of the energy from substrate dehydrogenation is transferred in a tight couple to high-energy phosphate. While the exact location and mode of its transfer is yet somewhat obscure, recent investigations do incriminate the submitochondrial particles located near the cristae. The question of whether morphological changes are produced by or cause biochemical changes is an academic one. The entire history of research on mitochondrial structure and function has shown that they cannot be separated; the final answer is a happy marriage of the two. It is our contention that this result will be necessary for solution of the oxygen toxicity problem.

ACKNOWLEDGMENTS

This work was performed by IIT Research Institute under contract with the Aerospace Medical Research Laboratories in cooperation with Air Force personnel including J. Young, M/Sgt., and J. Gillmore, A/IC, under the direction of H. P. Kaplan, Captain, USAF, MC. The program was initially monitored by P. Felig, Captain, USAF, MC; F. R. Robinson, Major, USAF, VC; and D. T. Harper, Jr., Captain, USAF, MC. Funds for this effort were supplied by the National Aeronautics and Space Administration.

IIT Research Institute personnel on location at the Aerospace Medical Research Laboratories were Mr. J. Q. Kissane, Mr. R. W. Bieber, and the author. Mr. M. Kardatzke participated in the original experimental design and the final statistical treatment of the data. We are grateful to Dr. E. J. Hawrylewicz for his continued interest and guidance in this program.

REFERENCES

1. Felig, O. and Lee, W. L., Jr., "Effects of Sodium Lactate on Oxygen Toxicity in the Rat". Ann. N. Y. Acad. Sci., Vol. 121, p. 829, 1965.
2. Chance, B., Jamieson, D., Coles, H., "Energy-linked Pyridine Nucleotide Reduction: Inhibitory effects of Hyperbaric Oxygen in vitro and in vivo". Nature, Vol. 206, p. 257, 1965.
3. Lowry, O. H., Passonneau, J. V., Schulz, D. W., Rock, M. K., "Quantitative Histochemistry of Retina. II. Enzymes of Glucose Metabolism". J. Biol. Chem., Vol. 236, p. 2813-20, 1961.
4. Burch, Helen B. and Dippe, Patricia Von, "Pyridine Nucleotides in Developing Rat Liver". J. Biol. Chem., Vol. 239, p. 1898, 1964.
5. Krasnow, N., Neill, W. A., Messer, J. V., and Gorlin, R., "Myocardial Lactate and Pyruvate Metabolism". J. Clin. Invest., Vol. 41, p. 2075, 1962.

DISCUSSION

FROM THE FLOOR: In one of your slides you had the cycle system laid out. I wonder if you know of any specific enzymes that should be investigated also?

DR. RIESEN: We have not examined any individual enzymes aside from those involved in the measurement of P/O ratios. We are planning to do this and I cannot answer you at the present time. I would like to say though that work in the in vitro systems with specific enzymes merely shows the overall capability of the enzymes, but when you are dealing with the whole animals exposed to oxygen, you have these things in situ. You've got them exposed to feedback systems, you've got them compartmentalized and so on, so that we do not feel we've got to work with the intact animal. If we could merely reduce ourselves to such a size, we could walk right into the mitochondria and see what we'd like to do.

FROM THE FLOOR: Do agents which uncouple oxidative phosphorylation like thyroid and others produce electron microscopic changes in tissues similar to the ones you've seen?

DR. RIESEN: I'd like to refer that to the electron microscopist.

DR. MAUTNER: Yes.

FROM THE FLOOR: You mentioned isoenzymes, did you find any differences at all?

DR. RIESEN: I failed to mention the fact that we did not find any significant changes in isoenzyme distribution. We do feel, however, that additional work is required here because we do want to look at homogenates of the tissues and this is in progress now.

DR. PIERSON (Lockheed Aircraft Corporation): When you mention significance - "highly significant" and "very significant" - is this with reference to biological significance or statistical significance?

DR. RIESEN: When we talk about statistical significance in connection with mitochondria you have to remember that they are fractionated and they are in suspension. We're talking perhaps about a family of kinds of mitochondria which, if they would be ultimately pure in preparation, and if studied in toto, would show overall effects. We were talking about tightly controlled experiments such as experiments 3, 4, 5, and 6, where an analysis of variance such as we did is an attempt to reduce the entire set of data to significant trends. This significance is based upon standard statistical technology, a simple analysis of variance.

DR. LEON (NASA Ames Research Center): I'd like to comment on some experiments we did exposing animals to 300, 450, 600, and 760 mm Hg of oxygen for a month. We noticed weight losses; however, we did food control experiments alongside and all of the weight changes were simply due to food intake. We can totally account for the differences in the weight simply on the basis of food intake.

DR. RIESEN: The next question I'd like to ask is why do the animals lose their appetite?

DR. MAUTNER: I guess they don't like oxygen.

HEMATOLOGIC EFFECTS OF INCREASED OXYGEN TENSIONS

Harold P. Kaplan, Captain, MC, USAF

Aerospace Medical Research Laboratories
Wright-Patterson Air Force Base, Ohio

INTRODUCTION

In commenting on the discovery of oxygen in 1775, Priestly (ref 1) recognized the potential toxicity of "dephlogisticated air" and may even have pinpointed the mechanism of its toxicity when he noted that "... as a candle burns out more faster in dephlogisticated air than in common air, so we might, as may be said, live out too fast, and the animal powers be too soon exhausted in this pure kind of air." It remained for Paul Bert (ref 2), in 1847, to demonstrate the dangers of hyperbaric oxygen, primarily as central nervous system (CNS) manifestations and for Smith (ref 3), in 1899, to find that exposure of birds, rats, mice, and guinea pigs to 100% oxygen at as little as 532 mm Hg total pressure was lethal within 4 days. Little attention was paid to the effects of increased oxygen tension on blood and hematopoiesis, until the classic studies of Campbell were published in 1927 (ref 4). He exposed mice, rabbits, and monkeys to 400 mm Hg of pure oxygen continuously for 3 to 4 weeks. He found up to 35% reduction in hemoglobin content without elevation of the reticulocyte count during exposure. With increase in oxygen tension, there was a concomitant increase in the color index of the blood to levels resembling those seen in pernicious anemia. However, no change in the size or type of red blood cells could be demonstrated. After return to an ambient atmosphere, reticulocytosis to 8% occurred with reversion of hemoglobin levels to normal and the disappearance of a transient lymphocytosis which had occurred during exposure.

Boycott (ref 5), attempting to reproduce Campbell's findings, exposed rats to gradients of 50 to 95% oxygen at one atmosphere pressure in a closed chamber. He used reticulocyte counts in the peripheral blood as an index of marrow erythropoietic activity and found that exposure to 65% oxygen or greater for approximately 2 months led to a slight fall in hemoglobin preceded by a fall in reticulocyte count. He concluded that increased oxygen tensions suppress erythropoietic activity as an adaptation phenomenon, just as decreased oxygen tensions stimulate erythropoietic activity. This appeared to be a self-limited effect leading to equilibration at a lower hemoglobin level and not resulting in any significant degree of anemia.

In 1934, Behnke et al (ref 6) exposed three human subjects to 4 hours of inhalation of pure oxygen at one atmosphere and noted leukocytosis. The red cell fraction was not examined. Becker-Freyseng and Clamann (ref 7), in 1939, exposed themselves to 94% oxygen at 0.9 atmosphere (578 mm Hg), and had to terminate the exposure at 65 hours because of fatigue, reduced vital capacities and vomiting. During the exposure, significant leukocytosis developed but no impressive change in the red cell population occurred. Binet and Bochet (ref 8), in 1938, observed an initial decrease in the red cell count induced by exposure to oxygen followed by a rebound increase later in the exposure. Anthony (ref 9), same year, found that when a man inhaled pure oxygen by mask for several hours there was a 3-5% drop in hemoglobin and a 7-8% fall in the red count.

The occurrence of incapacitating pulmonary pathology with only brief exposure to more than 500 mm Hg of pure oxygen, precluded attempts to identify alterations in the normal 120-day life span of the red cell. In 1944, Rainhard (ref 10) circumvented this problem by using subjects with sickle cell anemia who, under ambient conditions, had short red cell survival times and maintained high reticulocyte levels. With 8-20 day exposures to 80% oxygen at one atmosphere he was able to measure large drops in both the red count and the reticulocyte levels. Tinsley (ref 11), using similar subjects in 1949 plus others with chronic hemolytic anemias and pernicious anemia, also found a significant reduction in reticulocytosis and red count after 8-14 days exposure to 50-100% oxygen at one atmosphere by mask. By using radioactive tagging, he demonstrated that the uptake of iron from hemoglobin synthesis was also depressed. This was also found to occur in normal persons breathing increased amounts of oxygen but to a quantitatively lesser extent. All of these measurements returned to normal with return of the subject to an ambient environment.

In 1947, Ohlsson (ref 12) exposed men for about 50 hours in a chamber containing 78-88% oxygen at one atmosphere of pressure. Although various upper respiratory irritant effects, paresthesias, and mental aberrations evolved, the only hematologic change seen was a minimal leukocytosis in one subject.

Unfortunately, much of this early work suffered from poor technical control. Masks and chambers leaked and true oxygen concentrations were often probably well below the desired and assumed levels. It was not until the recent renewal of interest in oxygen toxicity, sparked by the advent of hyperbaric medicine, the use of air or oxygen at pressures greater than atmospheric for therapeutic purposes, the requirements of manned space flights, and the development of more sophisticated equipment and instrumentation, that hematologists turned in earnest to the investigation of oxygen.

RECENT RESEARCH WITH HUMAN SUBJECTS

In 1958, Michel et al (ref 13) exposed six men to 80% oxygen at a total pressure equivalent to 10,000 feet above sea level (523 mm Hg) for 7 days. Although upper respiratory irritation and reversible pulmonary parenchymal changes were seen, there was no apparent effect on the hematologic system. A report by Hall and Martin in 1960 (ref 14) of exposure of a man to 100% oxygen at 181 mm Hg total pressure included a normal hemogram.

Perhaps the greatest amount of data arising from land based exposures of humans to increased oxygen tensions has been collected at the USAF School of Aerospace Medicine at Brooks Air Force Base, Texas.

In the days immediately preceding the first United States manned space flights, as part of the program to develop a safe space cabin atmosphere, they exposed two men to 40% oxygen at about 7 psi total pressure (partial pressure of oxygen -- 150 mm Hg or equivalent to ambient partial pressure) for 30 days, and two men to 100% oxygen at 3.8 psi (176 mm Hg of oxygen) for 17 days (ref 15). Their data indicated that both subjects exposed to the slightly increased oxygen tension of 176 mm Hg had a fall in hematocrit of 3-6% with concomitant decrease in blood volume which was not entirely plasma loss. One of the two subjects

The Gemini 5 mission which lasted 8 days, or twice the duration of Gemini showed similar trends. Here the astronauts underwent more extensive hematologic examination including ^{51}Cr red cell mass, red cell survival determinations, and reticulocyte counts. Mild leukocytosis was seen with an increase from 9,650 to 11,150 in one pilot and 6,850 to 7,125 in the other, again with neutrophilia and relative lymphocytopenia. Red cell count and hematocrit remained unchanged but by direct determinations total circulating red cell mass was reduced 20% in both pilots, with plasma volume reduced to a lesser extent (12%). Although the half-life of ^{51}Cr tagged red cells was reduced from a normal of 22-29 days to an observed 17-18 days, there was no direct evidence of hemolysis. Reticulocyte counts dropped from preflight levels of 2.2 and 1.8% to postflight levels of 1.0 and 0.55%, respectively. No change occurred in serum bilirubin levels or in red cell morphology (ref 26).

These findings, in turn, led to a further expansion of the hematologic survival of the astronauts involved in the 14-day Gemini 7 flight. The command pilot again responded with a 19% drop in circulating red cell mass, and a decrease in ^{51}Cr tagged red cell survival during flight. The slope of the survival curve, however, suggested that no suppression of erythropoiesis had occurred. Additional studies revealed that his red cells had increased osmotic fragility and that his mean corpuscular volume (MCV) had risen from a preflight level of 88 to 105 with concomitant fall in mean corpuscular hemoglobin concentration (MCHC). An abdominal scan indicated a 30% increase in the spleen-liver ratio, suggesting hemolysis and sequestration of erythrocyte debris in the spleen. Again, reticulocyte counts were not elevated immediately postflight and bilirubin levels were normal. Urinary urobilinogen determinations were performed but the results of these tests are not yet available. A reevaluation 20 days after the conclusion of the flight revealed a slight reticulocytosis of 3.6%, normal osmotic fragility, and red cell mass and survival. The second pilot did not show these hematologic changes but was found to have Gilbert's disease and must be considered separately (ref 27).

Several tentative conclusions may be drawn from these observations. First, there is a consistent decrease in the volume of circulating red cells that seems to be associated with changes intrinsic to the red cell, affecting its integrity and predisposing it to hemolysis, as evidenced by changes in red cell survival, osmotic fragility and spleen scans. It remains unclear whether these are oxidative changes resulting from increased arterial blood oxygen tensions or mechanical changes resulting from splanchnic pooling and stagnant anoxia secondary to prolonged weightlessness or to increased gravitational forces during reentry. Second, and perhaps of even greater significance, these changes are, beyond a possible minimal threshold, probably self-limited, since they are no more impressive at 14 days than at 8; and third, they are apparently reversible after return to ambient conditions.

Simultaneously, many intriguing questions are raised by these findings. Do they represent pathology potentially harmful to the organism, or are we merely seeing a physiological adaptation similar to, and the reverse of, the secondary polycythemia seen in individuals who normally live at the lower oxygen tensions high altitudes? Is the failure of the individual with Gilbert's disease to show these changes the result of some unexplained protective factor shielding him from a pathologic change, or an inability to make a necessary physiological adaptation to a change in environment? The data available so far is necessarily meager and

exposed to 150 mm Hg of oxygen also had a comparable fall in hematocrit, and both lost plasma and red cell volume. Blood sampling alone is probably an adequate explanation for the apparent small loss of red cells, and the authors' conclusion that no hematologic abnormalities were seen would appear reasonable. In 1964 (ref 16), they reported observations of eight normal subjects exposed continuously to increased oxygen tensions for 30 days. Four were exposed to a total pressure of 700 mm Hg, of which 33% was oxygen (233 mm Hg of oxygen), and the other four to a total pressure of 258 mm Hg which was 98.5% oxygen, a simulation of the present space cabin atmosphere. This arrangement yielded an arterial blood P_{O_2} of 177.7 mm Hg in the 700 mm Hg group, and 169.7 mm Hg in the 258 mm Hg group. Therefore, they were evaluating the effects of increased arterial oxygen tensions in both groups and comparing the effects of different total pressures between groups. Their findings were hematocrit reductions of 6.7% in the 700 mm Hg group, and 9.1% in the 258 mm Hg group. Other measurements included reticulocyte counts, Heinz Body* counts, determination of erythrocyte osmotic fragility, fecal and urine urobilinogen levels, serum bilirubin levels, red cell glutathione stability, glucose -6 - phosphate dehydrogenase (G-6-PD) levels, and lactic dehydrogenase levels. ^{51}Cr red cell survival studies and determinations of red cell utilization of iron were also included. None of the above showed any deviation from normal. They also indicated that the modest fall in hematocrit took place gradually during the first 14 days and then levelled out, and a reticulocytosis did occur in both groups after return to ambient air. Total and differential leukocyte counts were unaltered throughout the study and red cell morphology was unchanged. In effect then, although there was an unexplained drop in hematocrit and a later reticulocytosis, no evidence of hemolysis was seen. Morgan et al (ref 17) exposed men in a two-man space cabin simulator to 100% oxygen at 258 mm Hg total pressure for 14-day periods. He noted a slight drop in hematocrit during the first seven days with return to preflight levels during the last 7 days in three of four subjects. Leukocyte counts and differentials remained unchanged. Subsequent similar experiments failed to show any change at all in hematocrit, and the possible role of excessive blood sampling in the slight depressions initially seen cannot be dismissed.

In 1963, Mammen et al (ref 18) reported a study done by the U. S. Navy at the Air Crew Equipment Laboratory in Philadelphia. Six Naval and Marine aviators in good health were individually maintained in 100% oxygen at 5 psia in an altitude capsule attached to a centrifuge arm. They were each subjected to two pulses of acceleration of about 7 G lasting 2 minutes each and then transferred to a larger chamber, maintained at the same pressure, where they lived for 14 days. On the 15th day they were returned to the centrifuge capsule and subjected to a "reentry profile" of about 11 peak G and then returned to an ambient environment. Hematologic studies included hemoglobin and hematocrit, red and white blood cell counts, differentials, reticulocyte counts, platelet counts, and osmotic fragilities. Serum bilirubin and urine urobilinogen values were also determined. Significant changes included decreases in hematocrit and hemoglobin, and leukocytosis with neutrophilia. There was a slight rise in reticulocytes and a slight microcytosis but not to a statistically significant degree. All other parameters remained normal. Follow-up studies done 3 months after exposure showed a return of all measurements to

*Heinz Bodies: Water insoluble stainable granules seen in the red cell in oxidative hemolytic anemias, thought to consist of denatured protein, including globin, resulting from oxidative destruction of hemoglobin (ref 21)

pretest levels. Blood sampling resulted in a 700 ml blood loss for each subject the total blood picture was more consistent with mild blood loss than with hemolysis.

Most recently (ref 19), at the same laboratory, the Navy exposed six aviators to 7 days of confinement in a chamber at sea level pressure breathing air, followed by 20 days breathing pure oxygen at 5 psi (258 mm Hg) and then another 7 days under ambient conditions. The subjects wore full pressure suits for the last 30 days and ate a simulated spacecraft diet. Hematologic determinations included complete blood count, red cell indices, reticulocyte count, Price-Jones curves, osmotic fragilities, and direct and indirect bilirubin. No significant changes in trends were seen.

Conflicting observations arose from a study conducted by the Republic Aviation Corporation and reported by Helvey et al in 1962 (ref 20). Twenty-eight men were divided into four groups and sealed for 14 days in altitude chambers. The control group was maintained in air at 14.7 psi. The other three groups were maintained in pure oxygen at 7.4 psi (380 mm Hg), 5 psi (258 mm Hg), and 3.8 psi (196 mm Hg). The controls developed no significant red cell changes but did have a reversal of the polymorphonuclear and lymphocyte ratios on differential count of the white cells. At 5 psi, however, a consistent drop in hemoglobin with concomitant rise in reticulocyte count was seen in all subjects. The Price-Jones curve, a reflection of variations in red cell diameter within the entire red cell population, showed broadening and flattening consistent with the anisocytosis and microcytosis seen on smear. All subjects had increased red cell osmotic fragilities at the conclusion of the run. The morphologic abnormalities were still present 9 and 11 weeks after return to ambient air. Heinz bodies could be demonstrated on incubation of blood from two of the subjects. The group involved in the 7.4 psi run showed the most marked abnormalities. Bilirubin, urine urobilinogen, osmotic fragilities and post-run bone marrow studies were done on all subjects in this group and resultant data supported the presence of hemolytic anemia in all subjects. In this run, however, macrocytosis was seen, rather than microcytosis. Again decreased hemoglobin and continued reticulocytosis could still be demonstrated 8 weeks after the completion of the run. The hematologic picture in the 3.8 psi run resembled that of the 5 psi run except for the occurrence of a more marked reticulocytosis. Leukocytosis with lymphocytosis developed in some subjects in all groups.

The authors theorized that they had possibly induced oxidative hemolytic anemias similar to those caused by chemical oxidants or primaquine-like drugs. Considerable controversy was aroused by this study because the findings were not consistent with those of other studies of exposed human volunteers, and because their 5 psi run simulated the atmosphere being used for our manned spaceflight program. Roth, in his review of oxygen toxicity (ref 22), points out that the presence of toxic oxidation products from the polyurethane-toluene-diisocyanate insulation of the liquid oxygen pipes or mercury from broken thermometers and psychrometers may have played a significant role in the etiology of the hemolysis seen by Helvey and his group. The question remains controversial and unresolved but others observing human exposure to increased oxygen tensions have been unable to confirm Helvey's findings.

Recent interest in oxygen at high pressure (OHP, hyperbaric oxygen) as a medical tool has yielded additional information on the hematologic effect of oxygen tensions manyfold greater than those discussed above. Mengel (ref 23) has described a 64 year old Negro male who developed in vivo hemolysis after 26 minutes exposure to 30 psi of 100% oxygen. However, he pointed out that this man's erythrocytes demonstrated abnormalities prior to exposure that probably predisposed him to hemolyze. Studies of 20 other patients before and after exposure to OHP failed to reveal any evidence of in vivo hemolysis.

MANNED SPACE FLIGHTS

No hematologic abnormalities arose from the Project Mercury flights but these were of relatively short duration and no attempt was made to monitor parameters other than the basic hemogram. However, interesting data has arisen from the Gemini 4, 5, and 7 flights which involved 4-, 8-, and 14-day exposures, respectively (figure 1).

	<u>GT4</u>	<u>GT5</u>	<u>GT7</u>
HEMATOCRIT	N	N	N
RETICULOCYTES	—	↓	N
TOTAL BLOOD VOLUME	↓	↓	N
RED CELL MASS	↓ 8%	↓ 20%	↓ 19%
T _{1/2} Cr ⁵¹	—	↓	↓
WBC	↑	↑	↑
OSMOTIC FRAGILITY	—	—	↑
SERUM BILIRUBIN	—	N	N

Figure 1. SUMMARY OF HEMATOLOGIC FINDINGS FROM GEMINI 4, 5, AND 7 MISSIONS

Examination of the astronauts immediately following recovery of the Gemini 4 capsule revealed mild to moderate leukocytosis. The command pilot's white blood cell count increased from a preflight level of 7,700 to a postflight level of 12,000, and the pilot's from a preflight level of 7,850 to a postflight level of 29,050. An absolute neutrophilia and relative lymphocytopenia occurred in both. These changes had almost completely reverted to normal by the following day. Although no change in hematocrit or red cell count was immediately seen postflight, blood volume determinations using ¹²⁵I indicated a loss of approximately 400-500 cc during the flight. By indirect calculations using the measured hematocrit, it was concluded that in addition to plasma loss there had been a 13% drop in the circulating red cell mass (ref 24). Subsequent recalculations based on central/peripheral hematocrit ratios suggest that the deficit was closer to 8% (ref 25).

incomplete, and merely points to the need of further intensive investigation of the questions. It is noteworthy that the Russians have reported reduced circulating blood volume in cosmonaut Titov after his 1-day orbital flight, and reduced post-flight hematocrit values in Nikolayev and Popovich after 4- and 3-day flights, respectively, despite marked dehydration which should have been reflected by increased hematocrits (ref 28). The latter also developed leukocytosis, primarily the result of lymphocytosis. Yegorov and Feoktistov, after a 24-hour Voskhod flight, also exhibited leukocytosis with lymphocytosis. No change in hematocrit was reported (ref 29). All of these Soviet space missions utilized air at ambient pressure (760 mm Hg) as the space cabin atmosphere. Unfortunately, these data are limited but when combined with the inability of most investigators to induce *in vivo* hemolysis in man with land based exposures to hyperoxic environments, it points out the need for considering in defining the pathogenesis of hematologic changes weightlessness, confinement, and accelerative forces, and the resultant circulatory dynamic changes induced by these.

Recently, at the USAF School of Aerospace Medicine, five human volunteers maintained bedrest for 6 weeks in a windowless chamber in an attempt to study the role of prolonged inactivity on the dynamics of blood formation. Although the results of this study are as yet unpublished, preliminary data indicate that inactivity alone is sufficient to cause a significant depletion of circulating red cell mass (ref 30).

RECENT EXPERIMENTS WITH ANIMALS

In recent years, animals have been experimentally stressed with increased oxygen tensions to an extent that would be impossible with human volunteers. In this laboratory monkeys, dogs, rats, and mice were exposed continually to pure oxygen at 5 psia for 236 days or approximately 8 months, in a simulated space cabin environment. To our knowledge, no other animals or men have ever been exposed to that atmosphere for that length of time. Clinical laboratory studies were performed on blood obtained at regular intervals from the monkeys and the dogs. Samples were obtained without removing the animals from the experimental environment. After about 2 weeks of exposure, a slight but significant fall in hematocrit, hemoglobin and red cell count was seen in the monkeys. However, this stabilized rapidly so that at 90 days the average hematocrit and red cell count were essentially the same as seen at 2 weeks. No change was seen in the dogs. A slight simultaneous leukocytosis was present in both groups of animals. After 8 months, monkeys continued to have depressed hematocrits, hemoglobins and red cell counts when compared with controls being maintained simultaneously in ambient air, but the level of depression was no greater at 8 months than at 3 months or 2 weeks. Again, dogs showed no changes (ref 31). These findings are consistent with data obtained from the Gemini astronauts and suggest that we are dealing with a self-limited process which is not indefinitely progressive with increased duration of exposure. The lack of response in the dogs suggests that the dog is not a good subject for these studies because of possible circulatory characteristics peculiar to that species.

Observations in smaller animals have been less extensive. Agadzhanian (ref 32) exposed rats to 90% oxygen at 198 mm Hg total pressure for 100 days. He observed an initial rise in hematocrit, red cell count, and reticulocytes which

lasted for 43 days and then reverted to normal. However, he also noted a significant weight loss thought to be mostly dehydration. It is conceivable, especially in the presence of reticulocytosis, that the increased hematocrit was a reflection of hemoconcentration and that there was usually a total body red cell deficit. Again, there was apparent adaptation and these changes and others, including pulmonary atelectasis, eventually reverted to normal while the animals were still in the experimental environment.

Felig (ref 33) exposed rats to a 100% oxygen at 5 psi for 2 weeks and found it to be a benign environment except for the occurrence of statistically significant, but minimal fall in hemoglobin and red cell count. There was no concomitant reticulocytosis or increase in serum bilirubin levels.

The preceding studies have dealt with situations where the partial pressure of oxygen in the environment was only slightly above normal. However, exposure of animals to hyperbaric conditions, where the oxygen tension in the blood is increased fivefold or more, has shown that large increments in oxygen tension definitely do affect the red cell. Mengel and his co-workers (ref 23) have studied this problem extensively, primarily in mice and dogs and also in humans, as noted earlier. Earlier work by Raiha (ref 34) had clearly shown that tocopherol (vitamin E) was effective in preventing hemolysis resulting from in vitro incubation of red cells with hydrogen peroxide (presumably by preventing the peroxidation of essential erythrocyte intracellular enzymes or hemoglobin). On the basis of that finding Mengel et al (ref 35) investigated the utility of vitamin E in preventing oxidative hemolysis in animals exposed to OHP. Tocopherol deficient mice and tocopherol supplemented mice were exposed to 100% oxygen at 45 psia (3 atmospheres). Clear-cut hemolysis occurred in the deficient animals but not in the tocopherol pretreated animals. In vitro studies of blood from both groups of mice obtained after in vivo exposure to OHP revealed that red cells taken from the tocopherol pretreated animals were more resistant to in vitro hemolysis by hydrogen peroxide than those taken from the tocopherol deficient animals. In addition, the formation of lipid peroxides could be demonstrated in the red cell-hydrogen peroxide incubation mixtures from the deficient group but not from the tocopherol supplemented group. Exposure of 20 normal dogs to 3-4 atmospheres of oxygen to the point of convulsions, failed to cause in vivo hemolysis (ref 36). However, in vitro testing of red cells taken from these animals after their exposure, again indicated a greater sensitivity to lysis by hydrogen peroxide and formation of greater amounts of lipid peroxides than occurred in samples taken from the same dogs before exposure. Increased osmotic fragility could also be demonstrated in postexposure erythrocytes. No Heinz bodies were formed during OHP exposure and no increase in methemoglobin levels occurred.

Similar in vitro hydrogen peroxide hemolysis tests performed on blood obtained from human patients with chronic intestinal malabsorption and secondary tocopherol deficiency have further substantiated the importance of tocopherol in the maintenance of red cell integrity (ref 37). Tocopherol deficient patients exhibited consistently decreased resistance to peroxide induced lysis of their red cells in vitro. However, no evidence of in vivo hemolytic disease could be found in any of these individuals.

Interpretation of these data would suggest that even tocopherol deficient individuals have other naturally occurring antioxidant defenses to protect their red cell

membranes from peroxidation and subsequent lysis *in vivo*. Nevertheless, the role of tocopherol as a protective antioxidant may provide a useful key to understanding mechanisms of interaction between oxygen and the erythrocyte.

MECHANISMS OF ERYTHROCYTE-OXYGEN INTERACTIONS

The possible sites of interaction between oxygen and the red cell are many, and several mechanisms have been suggested for the pathogenesis of oxidative hemolytic anemias. These have included structural changes in the cell membrane, functional changes in intracellular metabolic pathways, oxidative degradation of hemoglobin, and combinations of these.

Any change in the composition of the cell membrane sufficient to alter its normal permeability could conceivably permit abnormal ionic and fluid shifts with resultant osmotic hemolysis. Nonenzymatic oxidation of unsaturated fatty acid in the cell membrane leads to the formation of unstable peroxides which decompose to malonylaldehyde. The interaction of 2-thiobarbituric acid with malonylaldehyde forms red pigments and quantitation of these pigments serves as an indirect measurement of lipid peroxidation (ref 38). Utilizing this method, Mengel has demonstrated increased lipid peroxidation accompanying and paralleling *in vitro* hydrogen peroxide induced hemolysis of red cells obtained from animals and humans exposed to OHP (ref 35, 36). However, attempts to similarly demonstrate lipid peroxidation occurring *in vivo* in normal subjects during or shortly after exposures to OHP have been unsuccessful. Bunyan (ref 39) also has been able to induce *in vitro* hemolysis by treating erythrocyte suspensions obtained from vitamin E deficient rats with dialuric acid, a chemical oxidant. Here too, hemolysis was paralleled by formation of lipid peroxides, whereas no peroxide formation occurred in cells hemolyzed by exposure to water. Mengel (ref 40) has reported additional *in vitro* studies of ultraviolet induced hemolysis. Cells that were sensitive to lysis by this agent formed lipid peroxides just before hemolysis occurred, demonstrating that the peroxidation precedes the hemolysis. Similar correlations have been made between the incidence of convulsions in animals exposed to OHP and the lipid peroxide levels in their brains (ref 41). Here again, tocopherol has been demonstrated to have a protective effect. Other antioxidants such as cobalt, manganese, and reduced glutathione also seem to protect against central nervous system toxicity by preventing lipid peroxidation (ref 39, 41).

In addition to the oxidative damage to sulfhydryl (-SH) groups in the cell membrane caused by lipid peroxide formation, there is similar inhibition of intracellular enzymes which contain -SH groups (ref 42). The effect of oxygen and oxidation on the intracellular erythrocyte enzymes, hemoglobin, and cellular energy production has been extensively studied. Most research to date has focused on enzymes known to be sensitive to chemical oxidants or oxygen itself and on enzymes known to decrease in activity with cell aging. Interpretation of this work requires a basic understanding of the unique metabolic pathways and reactions of the red cell.

Energy production in mammalian erythrocytes derives from two metabolic pathways (figure 2), the anaerobic Embden-Myerhof pathway and the aerobic phosphogluconic pathway or pentose phosphate shunt. The citric acid (Krebs) cycle, which is the major source of high-energy phosphate bonds in nucleated cells,

does not appear to function in red cells (ref 43). The Embden-Myerhof or anaerobic glycolytic pathway converts glucose to lactic acid with a net yield of two ATP for each mole of glucose entering the pathway. The pentose shunt generates CO₂ and NADPH (nicotinamide adenine dinucleotide phosphate - reduced) as an indirect source of energy.

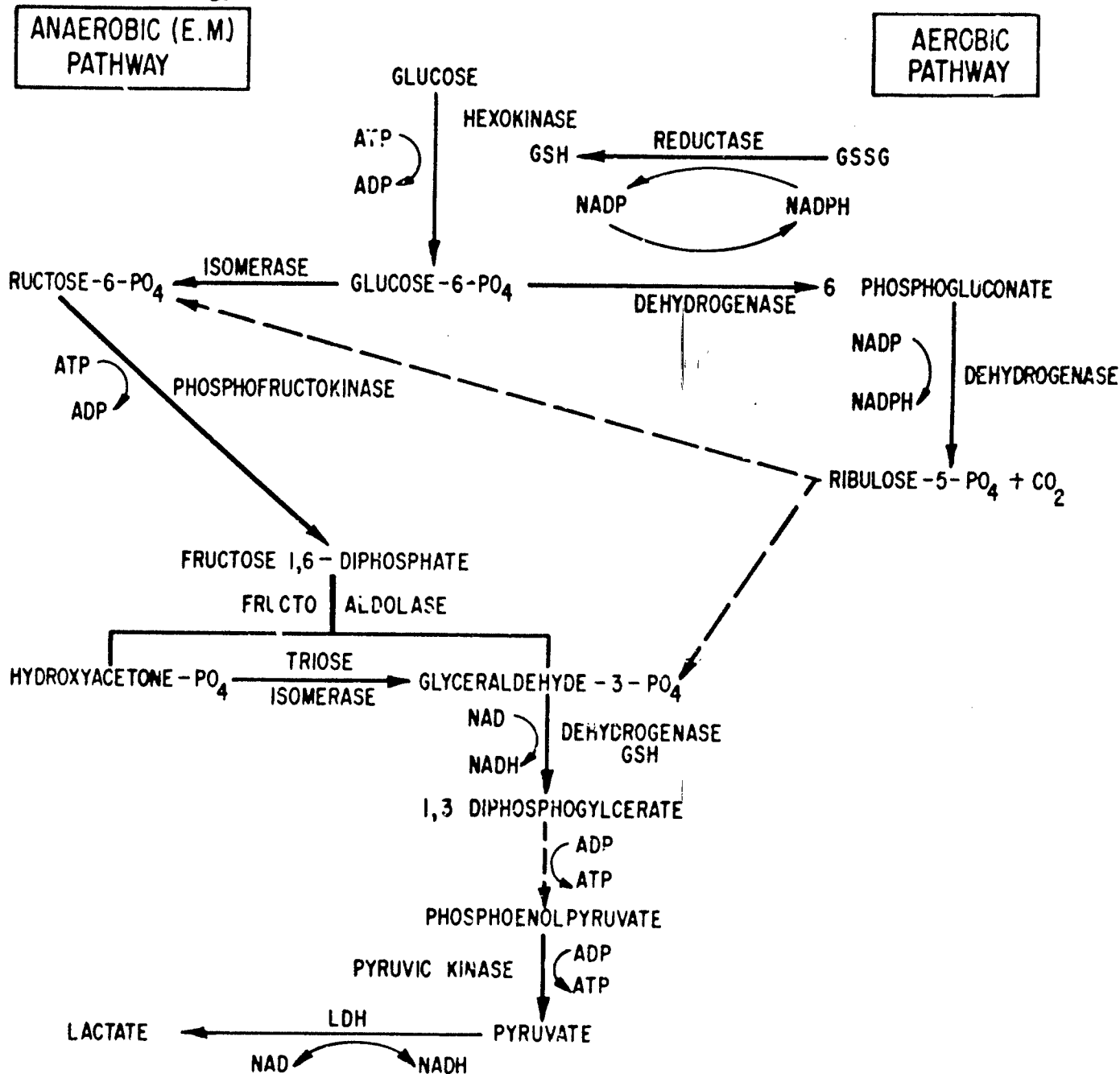

Figure 2. PATHWAYS OF GLUCOSE METABOLISM IN THE ERYTHROCYTE

The significance of the latter pathway, under normal conditions, is not clear. It has been determined that 11% of the glucose utilized by the red cell goes through this shunt, whereas 89% goes through the anaerobic glycolytic path (ref 43). By generation of NADPH, the shunt indirectly provides about 25% of the cell energy requirements. The rate of oxygen utilization in the blood is low compared to other tissues (ref 44), but incubation of red cells in a 100% oxygen environment will alter

the relative importance of these two metabolic pathways. Murphy (ref 43) found that in these circumstances glucose utilization by the anaerobic pathway dropped to 89% of normal while utilization by the aerobic pentose shunt increased to 162% of normal. He also noted that methylene blue, which oxidizes the NADPH produced by the shunt, will cause a slight decrease in total glucose utilization and marked increase in aerobic glucose metabolism. Crevasse and Hewson (ref 45) have similarly reported increased activity in the aerobic shunt and decreased activity in the anaerobic glycolytic pathway when the oxygen tension of the blood is increased. It would seem reasonable to assume that any breakdown in structure or function of the enzymes and cofactors involved in the pentose shunt would have a greater effect on the hyperoxic red cell than on the normal red cell.

The difficulty in establishing the role of variations in oxygen tension on red cell metabolism is accentuated by the myriad of interdependent reactions and collateral pathways. Breakdown in a single step can adversely affect a distant reaction dependent on some intermediate product of that step or, alternatively, might be rendered insignificant by the compensatory capabilities of some other pathway or step. *In vitro* studies are less than satisfactory for studying this problem because they often isolate the system under investigation from other systems which *in vivo* might significantly alter the observed results.

Specifically, there are at least four groups of intracellular components which must be evaluated to interpret the erythrocytes response to hyperoxic challenge.

The first of these is the group of oxygen sensitive enzymes in the erythrocyte including hexokinase, pyruvic kinase, glyceraldehyde-3-phosphate dehydrogenase, glucose-6-phosphate dehydrogenase, and others. Enzymes containing sulfhydryl groups have long been known to be susceptible to inactivation by oxidation. Deficiencies occurring in any of these enzymes involved in steps associated with the generation of ATP would lead to ATP deficiency and subsequent breakdown of ATP dependent steps in the Embden-Myerhof pathway, such as glucose to glucose-6-phosphate, and fructose-6-phosphate to fructose 1,6 diphosphate. Desforges (ref 46) speculates about many other enzymatic changes possibly associated with hemolysis. Because of the interdependence of so many steps in red cell metabolic pathways, there are many potential sites at which oxygen could disrupt cell inte-

Second of these groups is the pyridine nucleotides. Chance (ref 47) has demonstrated both *in vivo* and *in vitro* that exposure to hyperbaric oxygen leads to cellular depletion of NADH and NADPH, the reduced forms of the pyridine nucleotides. This is thought to be the result of inhibition of the normal mechanisms for reduction of the oxidized forms caused by the presence of manifold increased oxygen tensions. A cellular deficit in NADH or NADPH would lead to breakdown of enzyme systems dependent on these cofactors.

Gross and her group (ref 48) have utilized certain abnormalities present in the blood of full-term and premature newborn infants to study the role of pyridine nucleotides in red cell metabolism. These abnormalities include decreased red cell survival, increased susceptibility to Heinz body formation and to methemoglobinemia, and the occurrence of unexplained hemolytic anemias. They determined the concentrations of NAD, NADH, NADP, and NADPH in the cord blood of infants and in the blood of healthy adults. They found no difference in the levels between the two groups. This same group had previously demonstrated that there is no

decrease, but in fact, there is an increase in the activities of the pyridine nucleotide dependent enzymes in both the aerobic and anaerobic pathways of the erythrocytes in these infants, so the etiology of this hemolytic tendency remains obscure.

Third of these groups are energy rich phosphate bonds, primarily in the form of ATP (adenosine triphosphate), and the maintenance of adequate energy levels in the cell. Cellular integrity is dependent on energy stores adequate for ATP dependent enzymatic steps and to support mechanisms such as the postulated sodium pump which maintains intracellular levels of sodium and potassium against an osmotic gradient. Deficits in available ATP could result from breakdown of steps in the anaerobic pathway which normally yield ATP. Recent work done in this laboratory (ref 49) has shown that a breakdown in oxidative phosphorylation occurs in liver cells after *in vivo* exposure to oxygen at toxic levels and it is reasonable to assume that the same may occur in the red cell.

The fourth, and perhaps most important group, is the naturally occurring anti-oxidants. Work by Mengel (ref 35) has illustrated the potential role of one of these, tocopherol. The reduced pyridine nucleotides, in addition to their roles as enzymatic cofactors, probably also contribute to the protection of oxygen sensitive components by being preferentially oxidized.

Glutathione, particularly, seems to have a key role in maintaining cellular integrity by acting as a protective anti-oxidant. Reduced glutathione (GSH) protects both enzymes containing sulfhydryl groups and hemoglobin from oxidative breakdown by acting as a hydrogen donor (ref 50, 51). *In vitro* studies (ref 50) have shown that red cells in which all hemoglobin has been converted to methemoglobin by sodium nitrite, contain no GSH. Horse blood which is GSH deficient hemolyzes much more rapidly on exposure to air than normal horse blood, and the rate of hemolysis does not increase until the GSH level has fallen to at least 40% of its initial level. In addition, this protective effect of GSH is dependent on the presence of an additional nonhemoglobin protein factor or enzyme which Mills has called "glutathione peroxidase" (ref 51, 52, 53). This enzyme catalyzes the oxidation of GSH by hydrogen peroxide and appears to be much more effective than catalase in protecting the red cell from oxidative breakdown. The preferential oxidation of GSH uses up the threatening oxidant, thereby protecting other susceptible constituents of the cell. Glutathione is easily and directly oxidized by oxygen but normally in the presence of adequate amounts of glucose, glutathione reductase and NADPH is rapidly reduced again so that the equilibrium between reduced and oxidized forms remains constant. Jocelyn (ref 54) was able to shift this equilibrium by bubbling oxygen through a suspension of red cells deficient in glucose. In addition to finding a decrease in the concentration of reduced glutathione under these circumstances, he also noted a decrease in total glutathione both oxidized and reduced, and theorized that in a hyperoxic environment excess oxidized glutathione combines with proteins containing sulfhydryl groups to form inert GSS-protein disulfide bonds.

It would follow from this that although many studies of animals and humans exposed to hyperoxia have included glutathione determinations and have revealed no deficiencies, an adequate evaluation of the GSH system is impossible unless analyses of glutathione reductase, glutathione peroxidase and NADPH are included.

Additional clues to the mode of oxidative hemolysis are available from studies of hemolytic anemias induced by chemical oxidants. These are usually aromatic compounds with amino, nitro or hydroxy groups, but also include inorganic compounds (hydroxylamines, nitrates, nitrites and chlorates). The distinctive features of these anemias are (1) appearance of methemoglobin, and (2) formation of Heinz bodies (ref 21). Oxidative anemias are often accompanied by spherocytosis and increased osmotic fragility and old red cells are more susceptible than young. Negroes sensitive to primaquine are deficient in glucose-6-phosphate dehydrogenase, have low glutathione levels and form Heinz bodies when undergoing primaquine induced hemolysis (ref 55). In fact, studies of red cells from individuals susceptible to hemolysis from primaquine, sulfanilamides, acetanilide, primazone and acetylphenylhydrazine have shown that they are all relatively GSH depleted after hemolysis, and that the GSH depletion precedes the hemolysis (ref 56). The rate of hemolysis and GSH depletion in these cells is also accelerated by exposure to oxygen. In addition, when whole blood is incubated with phenylhydrazine, ATP levels fall with a concomitant rise in ADP and AMP levels (ref 57).

In Mengel's various studies of animals and humans exposed to hyperbaric oxygen (ref 40, 41, 34), there was no GSH or G-6-PD deficiency paralleling lipid peroxide formation and hemolysis and no increase in methemoglobin levels or appearance of Heinz bodies, even in tocopherol deficient mice that hemolyzed *in vivo*. However, in humans exposed to 2-4 atmospheres of oxygen for 8-10 hours they noted a decrease in ATP with concomitant increase in ADP and inorganic phosphate levels. In addition, Mengel noted an increase in levels of fructose 1, 6 diphosphate, and theorized that there may have been inhibition of the enzyme triosephosphate dehydrogenase (which is a sulfhydryl-bearing enzyme) causing a buildup of preceding intermediaries.

Desforges (ref 46), in a review of mechanisms of hemolysis, has emphasized the role of aging on the activity of several enzyme systems. Glucose-6-phosphate dehydrogenase (ref 58) and glyceraldehyde-3-phosphate dehydrogenase (ref 59) both decline in activity with aging. The former is essential for NADPH generation and the latter for the only NADH producing step. Decline in activity of these enzymes could lead to NADPH and NADH deficiency and consequent breakdown of NADPH and NADH dependent reactions. An example of this would be the conversion of glucose to glucose-6 phosphate. This step requires the enzyme hexokinase which, in turn, is dependent upon the presence of glutathione in the reduced state. The reduction of glutathione requires NADPH. Methemoglobin diaphorase, an enzyme effective in removing methemoglobin from the cell, is also NADPH dependent. The observation of increased methemoglobin content in older cells (ref 60) may be related to unavailability of this cofactor and breakdown of this reaction.

Probably because these NADPH and NADH dependent steps precede those responsible for high energy phosphate bond formation, older cells are also found to be relatively depleted in ATP, a factor which surely contributes to their ultimate demise (ref 57).

Therefore, it is not difficult to find many analogies between alterations in cellular membrane and intracellular components and activity normally arising as consequence of erythrocyte aging, and changes occurring on exposure of the red cell to a hyperoxic environment.

Danon (ref 61) has studied the effects of red cell aging extensively, and reports that older red cells have a higher specific weight, higher osmotic fragility, selective lower enzyme activities, different electrophoretic mobility, and alterations of the cell membrane that can be distinguished by electron microscopy. The young erythrocyte membrane is a granular structure with large, concentric foldings. The old cell membrane is thinner and smoother, larger in diameter, and has only a few folds. Using these criteria, he has determined that the circulation in humans and various other mammals normally contains 60-95% young erythrocytes, with the majority having between 80 and 90%.

A majority of old cells may be seen in cases of drug or viral induced hemolytic anemias or documented glucose-6-phosphate dehydrogenase deficiency. On the basis of these observations, a program supported by this laboratory was initiated by Dr. Danon to investigate the effects of increased oxygen tensions on the rate of red cell aging (ref 62).

Rabbits were exposed to 95-100% oxygen at sea level for 4 days. Blood was sampled periodically at 24-hour intervals for density distribution of red cells, osmotic and alkaline fragility of red cells, and enzymatic activity of G-6-PD and hexokinase. Red cell membranes were examined electron-microscopically. Rabbit blood showed marked alterations in age population of erythrocytes within 72 hours, with increased osmotic fragility, indicating that there was an increase in population of functionally older cells. Reticulocytes present at zero time disappeared after 48 hours, presumably as a result of maturation without replacement by hematopoiesis. No statistically significant alterations in enzyme activity were noted. Although these are preliminary data they suggest that Priestly's supposition made 200 years ago that oxygen may make us "live out too fast, and the animal powers be too soon exhausted" may have been quite correct.

With continued exposure Danon was able to demonstrate a secondary reversal with the return of higher concentrations of younger cells in the circulating blood and, on this basis, has proposed that the reduction in circulating red cell mass seen in the Gemini astronauts may be the result of sequestration of senescent cells in the postcapillary bed.

We may tentatively conclude that the changes associated with oxidative damage to the red cell may be the functional equivalent of accelerated aging, leading to a premature senescence and subsequent removal from the circulation. This would correlate well with the observation that young cells are more resistant to oxygen poisoning than older ones.

The effect of increases in oxygen tension on rate of red cell production has been less extensively investigated. It is known that hypoxia causes increased erythropoietin activity and this is the basis for some erythropoietin bioassay procedures. Whether the converse is true, i. e., hyperoxia causes decreased erythropoietin activity, is less certain. Early work done by Boycott (ref 5) suggested that erythropoiesis is suppressed when animals are maintained in a hyperoxic environment. Jacobson et al (ref 6) have stated that increase in the supply of oxygen when demand remains normal produces decreased erythropoiesis in the rat. Katchman (ref 64) was unable to show any significant alteration in erythropoietin levels in rats exposed to 100% oxygen at 1 atmosphere. However, his determinations were dependent on a bioassay technique which he concluded was

probably not adequately sensitive. Gyllensten suggests that those reporting increases in erythropoiesis in oxygen-poisoned animals may have failed to consider the possibility of preexisting hypoxia arising from pulmonary oxygen toxicity, and resulting secondary polycythemia. In contradistinction to these animal data, analysis of ^{51}Cr red cell survival curve obtained from the astronauts piloting the Gemini mission clearly indicates that erythropoietic rates remained normal. However, analysis of other land-based exposures of humans to similar oxygen tensions (at least on the basis of the consistent delay in the appearance of reticulocytosis, after return to an ambient atmosphere) continues to suggest that a significant increase in blood oxygen tension does suppress marrow erythropoietic activity to some extent.

SUMMARY AND CONCLUSIONS

Interest in the susceptibility of the red cell to variations in the oxygen tension of the circulating blood currently has two practical applications. One is the effect of the manifold increments experienced by individuals exposed to pure oxygen hyperbaric pressures of 2-3 atmospheres (1500-2300 mm Hg of oxygen) and the other is the significance of the modest increment resulting from prolonged confinement in manned space capsules where the atmosphere is pure oxygen at 1/3 atmosphere (258 mm Hg of oxygen) as compared with normal ambient levels (150 mm Hg of oxygen). It would appear that these situations must be treated independently and that extrapolations from one to the other are not necessarily valid.

The bulk of data arising from both animal and human exposures to increased oxygen tensions is both incomplete and inconsistent. An attempt has been made only recently to specifically study the hematologic effects of exposure to oxygen rather than just recording scattered hematologic data as peripheral observations in experiments designed for other reasons. Nevertheless, the analysis of available information would suggest the following:

1. The erythrocyte is sensitive to small variations in oxygen tension in the blood and the foci of sensitivity to increased oxygen tension are in the cell membrane where unsaturated fatty acids are subject to peroxidation, and intracellularly, where the balance between aerobic and anaerobic metabolic pathways is altered and the activities and integrity of various enzyme systems in both pathways are possibly affected. Resultant structural change in the cell membrane, oxidative degradation of hemoglobin, decrease in cellular energy production in the form of ATP, and deficit in intracellular antioxidants arising from decreased NAD and NADPH production and GSH stability, can interfere with normal ionic exchange and osmotic equilibrium and lead to cell lysis. These changes may be the same as those naturally occurring in cell aging and equivalent to an acceleration of that process.

2. Hematopoiesis, specifically erythropoiesis, is probably depressed by increased oxygen tensions just as it is stimulated by decreased oxygen tensions. This is a reversible change and may not be significant below a threshold which is greater than 258 mm Hg of oxygen.

3. When exposed continually to a space capsule environment of pure oxygen at 5 psi, the normal individual probably experiences a decrease in circulatory

red cell mass secondary to gradual hemolysis arising from the above cited mechanisms and occurring only after his antioxidant defenses are overcome. This reduction is not compensated for by increased erythropoiesis as long as the individual remains in the hyperoxic environment but is rapidly compensated on return to ambient oxygen tensions. The reduction is self-limited and not indefinitely progressive with increased duration of exposure, and possibly represents a desirable adaptation to the new environment.

4. When exposed to the markedly increased oxygen tensions of a hyperbaric chamber, an individual probably undergoes the same changes but at a relatively accelerated rate. The organism's ability to adjust to an altered environment may well be overcome in this situation because of the magnitude of the change and significant and progressive hemolysis may occur with increased duration of exposure. However, the greater sensitivity of the central nervous system probably is the limiting factor and convulsions would probably preclude further exposure before hemolysis became a significant factor.

5. Leukocytosis, seen in most of the exposures cited, is probably a nonspecific stress response. There have been no attempts to evaluate the effects of high oxygen tensions on white cell metabolism. Platelet concentrations and clotting mechanisms do not appear to be affected.

ACKNOWLEDGMENT

This work was funded in part by National Aeronautics and Space Administration (Ames) under NASA Contract No. R-87.

REFERENCES

1. Priestly, J. The Discovery of Oxygen, Alembic Club Reprints, No. 7, Uni Chicago Press, Chicago, 1906.
2. Bert, P. La Pression Barometrique. Masson, Paris, 1878, translated by Hitchcock, F. Barometric Pressure, Longs College Book Co., Columbus, C 1943.
3. Smith, J. L. "The Pathological Effects Due to Increase of Oxygen Tension the Air Breathed", J. Physiol. 24, 9, 1899.
4. Campbell, J. A. "Further Observations on Oxygen Acclimatization", J. Physiol. 63, 325, 1927.
5. Boycott, A. E., and Oakley, C. C. "The Regulation of Marrow Activity: Experiment on Blood Transfusions and on the Influence of Atmospheres Rich in Oxygen", J. Path. Bactiol. 36, 205, 1933.
6. Behnke, A. R., Johnson, F. S., Poppen, J. R., and Motley, E. P. "The Effect of Oxygen on Man at Pressures from 1-4 Atmospheres", Amer. J. Physiol. 110, 565, 1934.
7. Becker-Freyseng, H., and Clamann, H. G. "Zur frage der Sauerstoffverg", Klin. Wochensch. 18, 1385, 1939.
8. Binet, L., Bochet, M., and Bryskier, A. "Les Atmospheres Suroxygenees", J. de Physiol. et de Path. 37, 524, 1939.
9. Anthony, A. J., and Biedenkopf, H. "Der Einfluss Kurzdauernder Sauerstoffatmung auf Hämoglobingehalt und Erythrocytenzahl des Menschlichen Blutes", Z. F. Exp. Med. 103, 451, 1938.
10. Reinhard, E. H., Moore, C. V., Dubach, R., and Wade, L. J. "Depressive Effects of High Concentrations of Inspired Oxygen on Erythrocytogenesis: Observations on Patients with Sickle Cell Anemia, with a Description of the Observed Toxic Manifestations of Oxygen", J. Clin. Invest. 23, 683, 1944.
11. Tinsley, J. C., Moore, C. V., Dubach, R., Minnich, V., and Grinstein, J. "The Role of Oxygen in the Regulation of Erythropoiesis", J. Clin. Invest. 1544, 1949.
12. Ohlsson, W. T. L. "A Study of Oxygen Toxicity at Atmospheric Pressure", Acta Med. Scand. (Suppl. 190) 1, 1947.
13. Michel, E. L., Langevin, R. W., and Gell, C. F. "Effect of Continuous Human Exposure to Oxygen Tension of 418 mm Hg for 168 Hours", Aerospace Med. 31, 138, 1960.
14. Hall, A. L., and Martin, R. J. "Prolonged Exposures in the Navy Full Pressure Suit at Space Equivalent Altitude", Aerospace Med. 31, 116, 1960.

REFERENCES (cont'd)

15. Morgan, T. E., Ulvedal, F., and Welch, B. E. "Observations in the SAM Two-Man Space Cabin Simulator; II - Biomedical Aspects", Aerospace Med. **32**, 591, 1961.
16. Zalusky, R., Ulvedal, F., Herlocher, J. E., and Welch, B. E. "Physiologic Response to Increased Partial Pressure; III - Hematopoiesis", Aerospace Med. **35**, 622, 1964.
17. Morgan, T. E., Cutter, R. G., Shaw, E. G., Ulvedal, F., Hargreaves, J. J., Moyer, J. E., McKenzie, R. F., and Welch, B. E. "Physiologic Effects of Exposure to Increased Oxygen Tension at 5 psia". In "Gaseous Environment Considerations and Evaluation Programs Leading to Spacecraft Atmosphere Selection". NASA TN-D-2506, National Aeronautics and Space Administration, Jan. 1965.
18. Mammen, R. E., Critz, G. T., Dery, D. W., Highly, F. M., and Hendler, E. "The Effect of Sequential Exposure to Acceleration and the Gaseous Environment of the Space Capsule Upon the Physiologic Adaptation of Man". In Gaseous Environment Considerations and Evaluation Programs Leading to Spacecraft Atmosphere Selection. NASA TN-D-2506, National Aeronautics and Space Administration, Jan. 1965.
19. Kellett, G. L., and Coburn, K. R. "The Effects upon the Red Blood Cells of Subjects Exposed for a Prolonged Period to 100% Oxygen at 5 psi". Presented at the 37th Annual Scientific Meeting, Aerospace Medical Association, Las Vegas, Nevada, 18 Apr. 1966.
20. Helvey, W. M., Albright, G. A., Benjamin, F. B., Gall, L. S., Peters, J. M., and Rind, H. Effect of Prolonged Exposure to Pure Oxygen on Human Performance. Repub. Aviation Corp. 393-1, 30 Nov. 1962, and in NASA-TN-D 2506, National Aeronautics and Space Administration, Jan. 1965.
21. Jaudl, J. H., Engle, L. K., and Allen, D. W. "Oxidative Hemolysis and Precipitation of Hemoglobin I - Heinz Body Anemias as an Acceleration of Red Cell Aging", J. Clin. Invest. **39**, 1818, 1960.
22. Roth, E. M. Space Cabin Atmospheres, Part I - Oxygen Toxicity. NASA-SP-47, National Aeronautics and Space Administration, 1964.
23. Mengel, C. E., Kann, H. E., Heyman, A., and Metz, E. "Effects of In Vivo Hyperoxia on Erythrocytes II - Hemolysis in a Human after Exposure to Oxygen under High Pressure", Blood **25**, 822, 1965.
24. Gemini Program Mission Report - Gemini IV. NASA-MSC-G-R-65-3, June 1965.
25. Fischer, C. L. NASA-MSC, Houston, Texas. Personal Communication.
26. Gemini Program Mission Report - Gemini V. NASA-MSC-G-R-65-4, Oct. 1965.

REFERENCES (cont'd)

27. Fischer, C. L. Personal Communication.
28. "Soviet Manned Space Flights." In Highlights of Foreign Bioastronautics 2, #2, 14 Aug. 1964.
29. Vasil'yev, P. V., and Volynkin, Yu M. "Some Results of Medical Investigations Carried Out During the Flight of Voskhod", 2nd International Symposium on Basic Environmental Problems of Man in Space, Paris, 14-18 June 1965.
30. Morse, B. USAF School of Aerospace Medicine, Brooks AFB, Personal Communication.
31. Back, K. "Toxicity Studies on Animals Exposed Continuously for Periods up to 235 Days to a 5 psia, 100% Oxygen Environment", 2nd Annual Conference on Atmospheric Contamination in Confined Spaces, 4 May 1966, Dayton, Ohio
32. Agadzhanian, N. A. "Effects on the Organism of Prolonged Exposure (100 days) to Pure Oxygen at a General Pressure of 198 mm Hg". 2nd International Symposium on Basic Environmental Problems of Man in Space, Paris, 14-18 June 1965.
33. Felig, P. "Observations on Rats Exposed to a Space Cabin Atmosphere for Two Weeks". Aerospace Med. 36, 858, 1965.
34. Raiha, N. "Hemolysis of Human Blood Caused by Oxygen and Its Prevention with Vitamin E", Acta Paediat. (Uppsala) 44, 128, 1955.
35. Mengel, C. E., Kann, H. F., Smith, W. W., and Horton, B. D. "Effects of In Vivo Hyperoxia on Erythrocytes I. Hemolysis in Mice Exposed to Hyperbaric Oxygenation", Proc. Soc. Exp. Biol. & Med. 116, 259, 1964.
36. Zirkle, L. G., Mengel, C. E., Butler, S. A., and Fuson, R. "Effects of In Vivo Hyperoxia on Erythrocytes; IV. Studies in Dogs Exposed to Hyperbaric Oxygenation", Proc. Soc. Exp. Biol. & Med. 119, 833, 1965.
37. Binder, H. J., Herting, D. C., Hurst, V., Finch, S. L., and Spiro, H. M. "Tocopherol Deficiency in Man", New Eng. J. Med. 273, 1289, 1965.
38. Wilbur, K. M., Bernheim, F., and Shapiro, O. W. "The Thiobarbituric Acid Reagent as a Test for the Oxidation of Unsaturated Fatty Acids by Various Agents", Arch. Biochem. 24, 305, 1949.
39. Bunyan, J., Green, J., Edwin, E. E., and Diplock, A. T. "Lipid Peroxidation in Dialuric Acid - Induced Hemolysis of Vitamin E Deficient Erythrocytes", Biochem. J. 77, 47, 1960.
40. Kann, H. E., Mengel, C. E., Smith, W., and Horton, B. "Oxygen Toxicity and Vitamin E", Aerospace Med. 35, 840, 1964.

REFERENCES (cont'd)

41. Zirkle, L. G., Mengel, C. E., Horton, B., and Duffy, E. J. "Studies of Oxygen Toxicity in the Central Nervous System", Aerospace Med. 36, 1027, 1965.
42. Lewis, S. E., and Wills, E. D. "The Destruction of -SH Groups of Proteins and Amino Acids by Peroxides of Unsaturated Fatty Acids", Biochem. Pharmacol. 11, 901, 1962.
43. Murphy, J. R. "Erythrocyte Metabolism; II: Glucose Metabolism and Pathways." J. Lab & Clin. Med. 55, 286, 1960.
44. Denstedt, O. F. "Enzymology of the Erythrocyte". In Tullis, J., editor: Blood Cells, New York, 1953, Academic Press pp 197-243.
45. Crevasse, L., and Hewson, W. H. "Glucose Metabolism of Red Blood Cells." J. Lab & Clin. Med. 65, 539, 1965.
46. Desforges, J. F. "Erythrocyte Metabolism in Hemolysis", New Eng. J. Med. 273, 1310, 1965.
47. Chance, B., Jamieson, D., and Coles, H. "Energy Linked Pyridine Nucleotide Reduction: Inhibitory Effects of Hyperbaric Oxygen in vitro and in vivo", Nature 206, 257, 1965.
48. Gross, R. T., Schroeder, E. A., and Gabrio, B. W. "Pyridine Nucleotides in Erythrocyte Metabolism", J. Clin. Invest. 45, 249, 1966.
49. Riesen, W. H. "Cellular Biochemistry of Oxygen Toxicity." 2nd Annual Conference on Atmospheric Contamination in Confined Spaces, 4 May 1966, Dayton, Ohio.
50. Fegler, G. "Relationship Between Reduced Glutathione Content and Spontaneous Hemolysis in Shed Blood." Nature 170, 624, 1952.
51. Mills, G. C. "Hemoglobin Catabolism I - Glutathione Peroxidase, An Erythrocyte Enzyme which Protects Hemoglobin from Oxidative Breakdown", J. Biol. Chem. 229, 189, 1957.
52. Allen, D. W., and Jaudl, J. H. "Oxidative Hemolysis and Precipitation of Hemoglobin II - Role of Thiols in Oxidant Drug Action", J. Clin. Invest. 40, 454, 1961.
53. Hill, A. S., Haut, A., Cartwright, G. E., and Wintrobe, M. M. "The Role of Nonhemoglobin Proteins and Reduced Glutathione in the Protection of Hemoglobin from Oxidation in Vitro." J. Clin. Invest. 43, 17, 1964.
54. Jocelyn, P. C. "The Effect of Some Protein Solutions on the Oxidation of Glutathione in Oxygenated Erythrocytes", Biochem. 77, 368, 1960.

REFERENCES (cont'd)

55. Carson, P. E., Flanagan, C. L., Ickes, C. E., and Alving, A. S. "Enzyme Deficiency in Primaquine - Sensitive Erythrocytes", Science 124, 484, 1956.
56. Beutler, E. "The Glutathione Instability of Drug Sensitive Red Cells", J. Lab. & Clin. Med. 49, 84, 1957.
57. Mohler, D. N., and Williams, W. J. "The Effect of Phenylhydrazine on the ATP Content of Normal and G-6-PD Deficient Human Blood", J. Clin. Med. 1735, 1961.
58. Marks, P. A., Johnson, A. B., and Hirschberg, E. "Effect of Age on Enzyme Activity in Erythrocytes", Proc. Nat. Acad. Sci. 44, 529, 1958.
59. Löhner, G. W., Waller, H. D., Karges, O., Schlegel, B., and Muller, A. "Zur Biochemie der Alterung Menschlicher Erythrocyten", Klin. Wochenschr. 36, 1008, 1958.
60. Jalavisto, E., and Solantera, L. "Methemoglobin Reduction Rate of Nitrite Treated Red Cells as a Function of Cell Age", Acta Physiol. Scand. 46, 27, 1959.
61. Danon, D., and Perk, K. "Age Population Distribution of Erythrocytes in Domestic Animals - An Electron Microscopic Study", J. Cell and Comp. Physiol. 59, 117, 1962.
62. Danon, D. "Influence of Oxygen Toxicity on the Rate of Red Cell Aging", Administrative Report, Air Force Contract (unpublished data).
63. Jacobson, L. O., Goldwasser, E., Fried, W., and Plzak, L. "Role of Kidney in Erythropoiesis", Nature 179, 633, 1957.
64. Katchman, B. Evaluation of Techniques for Bioassay of Erythropoietin in Sera of Humans and Animals in Ambient and Hyperoxic Environments. AM TR-65-85.
65. Gyllensten, L., and Swanbeck, G. "Influence of Concentrated Oxygen on the Circulating Erythrocytes in Growing Mice", Acta Path. Microbiol. Scand. 45, 229, 1959.

DISCUSSION

DR. COULSTON: I'd like to ask a very simple and naïve question: why can't you account for all this by simply saying there was pooling in the splanchnic sinuses and the liver sinusoids?

CAPT. KAPLAN: Well, this is a very real question. This is what I meant to bring up in my remarks about circulatory dynamic changes. Namely, is it merely a question of the plasma volume in circulatory changes that we know occur in the weightless environment? Or is it splanchnic pooling and then stagnant hypoxia secondary to this occurring during the multiple G forces that occur on reentry? Or is it inactivity itself and what effect this has on circulatory dynamics? Or is it a combination of all these? I think the only thing that suggests that this is not the entire explanation (and I'm not really sure that it isn't) is the fact that if, due to deceleration and splanchnic pooling, you had a rapidly occurring hemolysis on reentry, you would probably immediately afterward (at least in the first day or couple of days) see overt evidence of hemolysis, increased urine urobilinogen and serum bilirubin levels plus reticulocytosis. This has not been seen. What we're stuck with really is that we have a decrease in circulating red cell mass and we're not really sure whether these cells are destroyed or just going somewhere else. Except that in the results of the Gemini 7 flights, the liver and spleen scans and the osmotic fragility studies all suggest that hemolysis really is occurring. Now I got the data on the Gemini 7 flight from Dr. Fischer who is here, and at the time I prepared this presentation the data was incomplete. He can make me look very silly now by telling you what else he has found out.

DR. THOMAS: Let's keep in mind that we have not seen this hemolysis in the 8 month animal studies. So this would weaken the argument for possible oxygen effects.

CAPT. KAPLAN: I omitted any mention of animal exposures for brevity's sake, but Dr. Back had mentioned there was no change in these animals and other work we've done with animals has shown occasionally only a minimal drop in hematocrit but nothing significant.

DR. THOMAS: Maybe this is not a toxicological problem. This might be a biodynamics problem.

DR. COULSTON: Before getting to any other people, I'd like to call on Dr. Danon. He's done a lot of work in this area.

DR. DANON (Weizmann Institute): Four years ago I wanted to find out what is the rate of aging of cells. My aim was to have an increased proportion of aging cells, cells that are in the status of passing from mature cells to old cells. One of the parameters that would describe the age distribution of cells was osmotic fragility. Unfortunately, the osmotic fragility test as it is generally carried out in the laboratory has several drawbacks. One, we need a large amount of blood (and I could not afford in my laboratory to work with humans and take 700 milliliters of blood). I wanted to work on mice or rats or rabbits and take only the amount of blood for osmotic fragility that will not induce reticulocytosis. We, therefore, developed a system which permits us to use the tiniest drop of blood that you can take

out of the tail tip of the mouse and will give you an automatically recorded osmotic fragility curve with its mathematical derivative giving the age distribution of cells. All this takes 5 minutes.

In the classical, conventional method the cells are submitted to gradually hypotonic solutions using about 20 test tubes. Everything must be very accurately controlled, including the hypotonicity, and you need a large amount of blood. The cells are then centrifuged down and the supernatant is analyzed in the photometer to find out how much hemoglobin leaked out. In our new method blood cells are suspended in an isotonic solution. The dialysis membrane is sitting in a beaker containing distilled water. As the water penetrates the dialysis membrane, the suspension of cells will be in a solution which becomes gradually more and more hypotonic.

Looking at this membrane at zero time you will see that the contents are absolutely opaque like every suspension of red blood cells. As osmotic pressure is reduced and the cells begin to hemolyze the solution becomes more and more transparent, the ghosts being unable to refract the light, and if you look at it in cinematography with the phase-contrast microscope the refractive index inside the ghosts and outside is identical and that is why they become transparent to the light. Now with a light source and a photoelectric cell this process can be recorded. As the cells hemolyze more, more light will reach the photoelectric cell. The main difficulty was in the use of this dialysis bag, which is definitely not an optical system. Finally we mounted the bag on a frame with an optical window. Thus we have a microcuvette, the volume of which is 40 λ , and inside are the cells suspended in isotonic solution. Now, introducing this microcuvette into a vessel containing distilled water, as hemolysis progresses we get an increasing signal which is transmitted to a recorder and is automatically recorded in 5 minutes. Also, the first signal at time zero is put into a capacitor and 1 second later the second signal. The difference between the change of the two capacitors is transmitted into a recorder and we get a derivative. This gives the age distribution of cells. The reproducibility is much beyond anything we are used to in the conventional method. We have taken mice and submitted them to pure oxygen to see how this shoulder in the derivative shifts. It shifted to the left, which means an increase in osmotically more fragile cells and, therefore, cells that are more aged. You will see also a kind of peak increase in the derivative, which means a more uniform population, because the young cells are maturing and new cells are not formed. Practically there is a complete arrest of formation of new reticulocytes.

FROM THE FLOOR: Is this pure oxygen at one atmosphere?

DR. DANON: No, it's not pure oxygen. It's between 95% oxygen and 100% oxygen at one atmosphere, and our oxygen analysis is done only every several hours. We have seen different reactions with different species. Some react in a more dramatic way. Rats are unreliable. They react in a very peculiar form. Sometimes you almost get the feeling they like oxygen. Therefore, we discontinued using rats. Also, we have put rats into the similar system using compressed air instead of oxygen and we obtained similar results. We don't know what happens with rats. So we went to guinea pigs, but finally we came to the conclusion that rabbits are ideal. I heard so many papers but nobody used rabbits. I don't know why. The most dramatic, most consistent effect was found in rabbits.

PSYCHOPHARMACOLOGICAL EVALUATION OF PRIMATES EXPOSED TO 5 PSIA 100% OXYGEN ATMOSPHERE

Thomas L. Wolfle, Captain, VC, USAF

6571st Aeromedical Research Laboratory
Holloman Air Force Base, New Mexico

INTRODUCTION

Since Paul Bert discovered the toxic effects of oxygen at increased pressures and embodied his findings in 1878 in his classic, *La Pression Barometrique* (ref 1), numerous investigators have studied the physiological effects of oxygen administered at high partial pressures. These are well documented by Bean (ref 2) and others (ref 3, 4, 5, 6).

As the prospects for prolonged manned space flights increase, so does the need for more definitive information about the spacecraft atmosphere. As pointed out by Morgan, et al (ref 7), the selection of a single gas atmosphere offers many advantages. There has been, however, a void in information about the effects of 100% oxygen at low ambient pressures, and the reports of behavioral effects of this environment are scarce indeed.

Davidson (ref 8), however, who studied behavioral effects in 1926 reported that oxygen at 1 atm had no effect on reaction times, but Shilling and Willgrube (1937) (ref 9) showed a slowing in problem solving and related this slowing to the subject's mental ability. The mental effects of oxygen at high pressures were first described in detail by Hill and Phillips (ref 10) in 1932. They associated certain "personality types" with the appearance of certain symptoms. Behnke, et al (1935) (ref 5), demonstrated that breathing oxygen at 3 atm caused progressive loss of peripheral vision; however, impaired neuromuscular coordination occurred in one out of four subjects who breathed oxygen at 1 atm for 1 to 2 hours. Furthermore, Harris, et al (1960) (ref 11), found that performance was unimpaired after breathing oxygen at 1 atm for 3.5 hours. More recently Beehler, et al (1963) (ref 12), demonstrated damage to the rods and cones of adult dogs (with retinal detachment) exposed to 0.8 to 1 atm for 48 hours. The etiology of this condition appears quite different from the well-known retrolental fibroplasia of premature human infants (ref 13).

Of the behavioral studies reported on humans (ref 14, 15, 16) at oxygen partial pressures of less than 250 mm Hg at 5 psia or less, it is not possible to state that this environment has adverse effects on behavior. Hartman, et al (ref 15), did observe significant decrements in response times to visual tasks as a function of low signal rates. They indicated that signal rates of less than 80 per hour adversely affected response times. This observation had been proposed a year earlier by McKenzie, et al (ref 16), after two ground-level cabin simulator studies. Morgan (ref 14) states that he and his co-worker were unable to demonstrate performance decrements as measured by (1) complex discrimination, (2) simple monitoring, and (3) encoding arithmetic. They were, in fact, able to show a decrease in reaction time over 14-day studies (at a pO_2 of 243 mm Hg at 5 psia), indicating task improvement.

Reynolds (ref 17) and Farrer (ref 18) have both shown that the chimpanzee exhibits no serious performance decrements at 5 psia, 100% oxygen for up to 80

The need for more information on performance changes which might be associated with a single gas environment, at altitude, over a significant period of time became apparent to personnel in the Toxic Hazards Division of the Aerospace Medical Research Laboratories, Wright-Patterson Air Force Base, Ohio. Consequently, we joined with them in designing this experiment to evaluate the effects on performance of breathing 100% oxygen at 5 psia for 90 days.

METHOD

Subjects

The subjects were 12 mature subhuman primates weighing between 3.6 and 7.0 kg. All third molar teeth were "in wear" in all subjects. The subjects' numbers, species and average weight are given in table I. All subjects had received extensive training for several months at the Aeromedical Laboratory, Holloman Air Force Base, New Mexico, on the behavioral tasks.

TABLE I
SPECIES AND WEIGHT OF SUBJECTS

<u>Subject No.</u>	<u>Species</u>	<u>Weight</u>	
		<u>Kg</u>	<u>Lb</u>
8	Macaca irus	3.64	8
9	Macaca irus	4.54	10
22	Macaca mulatta	6.36	14
25	Macaca mulatta	3.64	8
51	Macaca mulatta	3.18	7
52	Macaca mulatta	4.09	9
55	Macaca Mulatta	4.54	10
56	Macaca mulatto	3.86	8.5
58	Macaca mulatta	5.00	11
62	Macaca mulatta	4.32	9.5
70	Macaca irus	3.41	7.5
84	Macaca mulatta	5.00	11

Design

Eight work sessions per day constituted the daily experimental period, and each session was comprised of three integrated tasks.

In order to facilitate the analyses, all data gathered for each 5-day week was to be pooled and considered one work unit. For each behavioral task, then, there would be 1 week of ground level preexperimental baseline (Pr. B.), 13 weeks experimental data (I-XIII) at 5 psia, 100% oxygen; and 1 week postexperimental baseline at ground level (Po. B.).

Tests were planned to determine whether parametric or nonparametric statistics should be used to compare preexperimental baseline data with the 13 weeks of experimental data. It was further planned that, if the proper assumptions could be met, the preexperimental baseline means would be pooled for all subjects on each task and used to establish .05 confidence limits for predictive purposes.

Apparatus

The apparatus can most conveniently be divided into three components:

1. Individual work chambers, figure 1, were specifically designed to fit into the Thomas Dome hypobaric chamber (ref 19). Each work chamber provided adequate quarters for a small primate for an extended time period. In addition, each chamber was fitted with a psychomotor work panel and automatic system for water ad libitum.

2. Solid state electronic programming console (figure 1).

3. Thomas Dome Hypobaric Chamber.

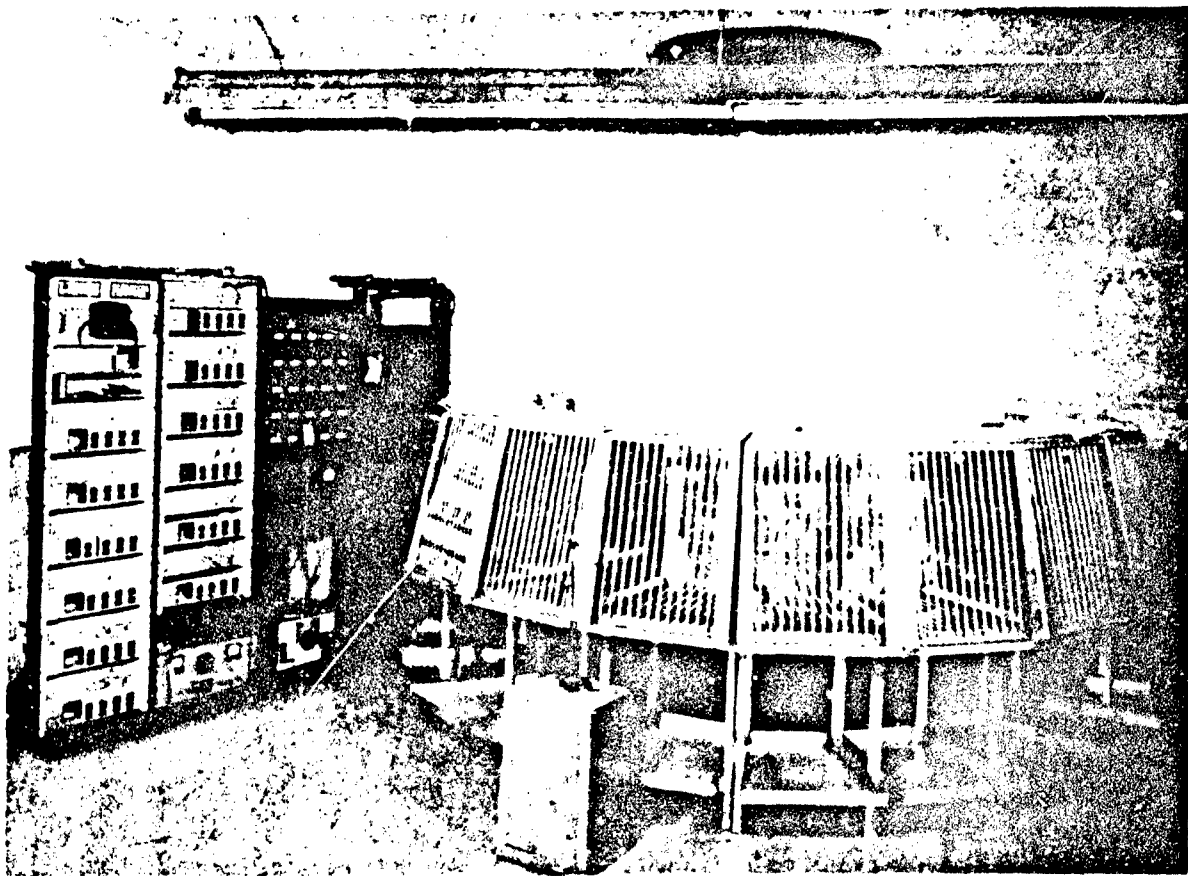

Figure 1. INDIVIDUAL WORK CHAMBERS AND ELECTRONIC PROGRAMMING CONSOLE

Performance Task

The schedule was essentially that described by Reynolds and Back (ref 20) with minor modifications.

The schedule was 15 minutes in duration, followed by a 45-minute rest period and consisted of three integrated tasks: (1) Dual Continuance Avoidance, (2) Auditory Response Time, and (3) Visual Response Time. The Discrete Auditory and Visual Tasks were superimposed upon the Continuous Avoidance Task (table II).

TABLE II

THOMAS DOME HOURLY WORK SCHEDULE

Min/Sec

0' 0"	Program Start	8' 00"	ART
0' 50"	VRT	9' 00"	VRT
0' 75"	ART	9' 30"	ART
1' 15"	VRT	10' 00"	VRT
1' 45"	ART	10' 30"	ART
2' 30"	ART	12' 00"	VRT
3' 00"	VRT	12' 30"	ART
4' 00"	ART	12' 45"	VRT
4' 30"	VRT	14' 00"	VRT
5' 00"	ART	14' 30"	ART
5' 15"	VRT	15' 00"	Program End
5' 30"	VRT	15' 01"	- 59' 59" Rest Period
5' 45"	ART	CA-15"	RS Interval
6' 30"	ART	ART-VRT-2"	RS Interval
7' 30"	VRT	ART-VRT	12 Presentations

1. Dual Continuance Avoidance (CA)

Two red lights signaled the start of this program which was to be in effect for the entire 15 minutes. A response to the right-hand lever, located under a red light, delayed shock for 15 seconds. Any failure to respond within a 15-second period resulted in a mild shock delivered through the floor and walls of the cage. A similar program was in effect utilizing the left-hand red light and lever.

The total number of shocks possible on this dual avoidance schedule was: 4 shocks per minute for 15 minutes = 60 shocks per lever or 120 shocks total per 15 minute work session.

2. Auditory Response Time (ART)

Superimposed upon the continuous avoidance schedule were twelve (12) randomly presented auditory signals (1000 cps, 80 db). Each presentation required a response on the stimulus response key through which the tone was

emitted. Failure to respond within 2 seconds after onset of the stimulus (RS interval = 2 seconds) resulted in shock. The total shocks possible on this task were 12 per session.

3. Visual Response Time (VRT)

Twelve randomly presented visual (yellow) signals were presented during the 15-minute work session. The time intervals were identical to the auditory task, i. e. 2 seconds RS intervals. A response consisted of depressing the stimulus response key from which the light emanated. The total shocks possible on this task were 12 per session.

4. Shock Avoidance Efficiency (SAE)

As an additional variable, all shocks received by the subjects on all tasks were summed and expressed as a percentage of the total number of shocks possible.

Procedure

Two weeks of preexperimental baseline data were obtained; the first week at Holloman Air Force Base, New Mexico and the second at Wright-Patterson Air Force Base, Ohio. Because of considerable differences between these 2 weeks in specific subjects, F-tests were performed on grouped data to test for differences between the variances of the two weeks. F was found to be significant (.05) for two variables, Auditory Response Time and Shocks, and thus the 2 weeks were not combined and only the latter (W-PAFB) week was used.

All 12 subjects underwent identical experimental conditions and were grouped together for the data analysis.

Data from the CA task were recorded as mean responses per minute; for ART and VRT as mean response times in hundredths of seconds and for shocks as Shock Avoidance Efficiency. It was thought more meaningful to present the shock data in terms of avoidance efficiency rather than simply total shock. When it is realized that each subject could receive 5760 shocks on all tasks per week, the efficiency of avoiding shocks, expressed as a percentage, becomes quite a meaningful indicator of overall performance.

Behavioral data were collected only 5 days a week as it was decided that over 13 weeks duration, the weekends would not add significantly to the reliability of the data and did not justify the additional manpower requirements.

Environmental Conditions

All subjects remained at altitude (5 psia) on 100% oxygen for the duration of the 13-week experimental period, except for three brief instances of power failure which caused some rise in pressure in the chamber. This occurred on days 3, 29, and 64. The durations of these periods was brief and the pO_2 changes accompanying the power losses were from 260 mm Hg to 560 mm, 280 mm, and an "insignificant change", respectively. The temperature was maintained at 72-74 F with a relative humidity ranging from 18 to 60%.

The subjects were fed and the chamber cleaned once daily. Entrances (through personnel locks) was generally limited to this daily routine and occurred at the end of the work day after all behavioral testing had been completed. Water was continuously available through lick valves maintained at 5 psia over chamber pressure.

Clinical Chemistry and Hematology

Blood samples were taken twice during baseline at ground level on days 15, 29, and 57 of the experimental phase and once during the postbaseline. All samples were collected in the mornings, before the subjects started to work for that day and 15 hours after the last feeding. The values studied were: for Hematology - WBC, Differential, Sedimentation Rate, RBC, Hematocrit, and Hemoglobin; and for Blood Chemistry - Sodium, Potassium, Calcium, Total Protein, Albumin, Alkaline Phosphatase, Total LDH, Total Phosphorus, SGPT, SGOT, and BUN.

Ten ml of blood was withdrawn from the femoral vein with the animal under physical (but not chemical) restraint.

RESULTS AND DISCUSSION

It is generally conceded that one would rather be on the cautious side in statistical interpretation and try to control Type I errors at the expense of increasing chances of making the Type II error. However, due to the nature of this study and the possibility of human safety resting on the outcome of this and similar studies, it was decided that the Type II error was most important to guard against. That is to say, we did not want to accept our null hypothesis and claim there is no difference between a small primate's ability to perform at ground level and at 5 psia (100% oxygen) when there just might be a difference. Thus, we chose to test our null hypothesis of no difference at the .05 level of significance instead of the .01 level using a two-tail test.

When the subjects responded to the discriminative stimulus within the allotted time (CA RS interval 15 seconds, ART and VRT RS intervals 2 seconds) and thus avoided shock, it seemed reasonable to conclude that, regardless of minor changes in behavior on other variables the shock avoidance efficiency provided the best single indicator of overall performance capability.

Table III groups all tasks together to show the mean shock avoidance efficiency for each subject for the following weeks: Baseline (Pr. B.), I, VII, XIII, and Postbaseline (Po. B.). Five of the twelve subjects (42%) never fell below 99% SAE. After the first week at altitude, when apparatus troubles caused numerous undeserved shocks, the least efficient subject in any one of the following experimental weeks received 373 shocks out of a possible 5760, resulting in a fairly impressive shock avoidance efficiency of 93.5%. This occurred in the 11th week of the study and was the only point (after the first week of equipment malfunctioning) at which the SAE fell below the 95% confidence limit. On the other hand, the upper limit of the confidence interval was exceeded during 4 different weeks. As a matter of interest, these four points correspond with the only points on the Left Lever Avoidance Graph which drop below the baseline mean (Pr. B.). This might be

explained on the basis of the subjects "attending" more closely to the total program, making only the minimal responses required to avoid shock on the CA, thus becoming more proficient in terms of overall shock avoidance efficiency. However, this explanation should be viewed cautiously.

TABLE III
REPRESENTATIVE SHOCK AVOIDANCE EFFICIENCY*

Subject No.	Pr. B.	I	Weeks			Po. B.
			VII	XIII		
8	98.8	92.6	97.5	99.5	99.7	
9	99.7	99.1	96.8	99.9	99.9	
22	99.7	99.1	99.9	99.9	100.0	
25	99.8	99.1	99.9	99.9	100.0	
51	99.6	98.4	99.8	99.9	99.9	
52	99.5	98.8	99.9	99.9	99.9	
55	99.6	98.6	100.0	99.9	100.0	
56	99.4	98.6	99.7	99.7	99.9	
58	99.4	99.6	99.9	99.9	99.8	
62	99.0	99.4	99.8	99.9	99.9	
70	98.7	97.6	99.6	99.9	97.7	
84	99.7	99.1	99.9	99.9	100.0	
Mean	99.4	98.4	99.4	99.9	99.8	

*Maximum shocks possible per subject per week = 5,760

Although the mean response latencies for the auditory presentations were significantly higher throughout the 13 weeks, these latencies never exceeded the 2-second allowable interval (maximum latency for any 1 week was 1.08 seconds). A statistically significant change from an established mean response time must be interpreted carefully by keeping in mind the range within which the subject is permitted to vary (0-2 seconds). For example, beginning with week 10 the Auditory Response Times increased considerably. This increase was associated with preventive maintenance on the Thomas Dome pumps the preceding weekend, which produced a 20% elevation of the background noise level within the Dome (from 87.5 to 105 dB). By week 11 one subject (No. 70) had stopped responding to the auditory signal and had begun receiving numerous shocks which might well have affected performance on the other tasks. At this point in the experiment, auditory presentations were eliminated from the program for all subjects. In addition, associated with the increased (decrement) mean auditory response time was a decrease (an improvement) in the visual response time to the lowest point during the experimental period, and a decrease in shock avoidance efficiency. The increased number of shocks can be explained on the basis of the increased auditory response times and are primarily attributable to the subject (No. 70) which had stopped responding to the auditory signal. The improvement in response time to the visual stimulus also probably results from increased "attending" to the stimulus panel, the motivation no doubt deriving from the increased number of shocks received due to the inability to detect the 1,000 cps 80 dB signal. To further substantiate that this increase in auditory response time and its resultant

effects on other portions of the schedule was due to a masking effect of the increased noise level, the postbaseline mean for the auditory response time returned to the limits predicted by the preexperimental baseline data. This strongly suggests that adequate background noise control was never achieved during the 13 weeks altitude. In future studies of this nature either (1) auditory signals must be delivered from the program or (2) a significant reduction in background noise must be achieved.

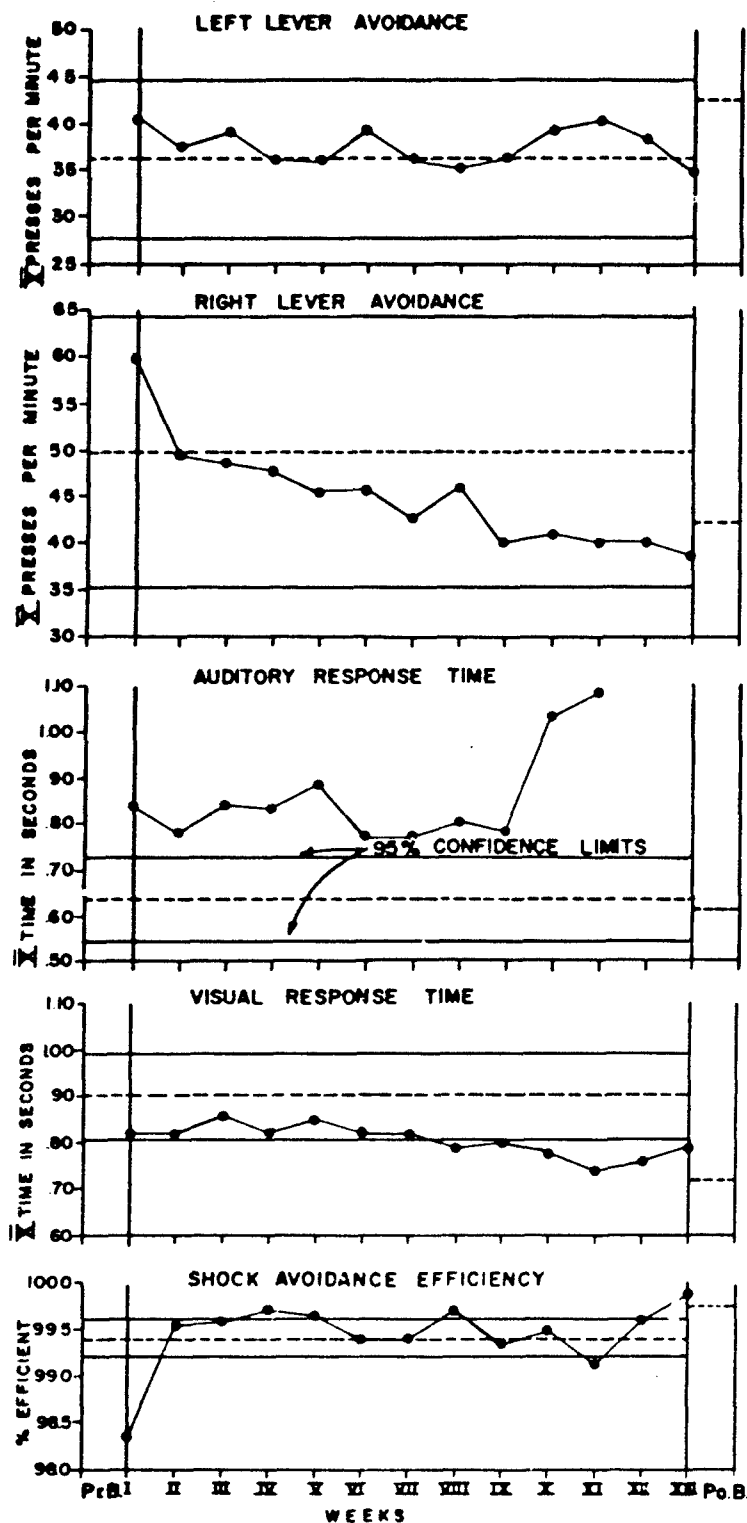

Figure 2. BEHAVIORAL DATA. All subjects combined with pre-experimental baseline means (Pr. B.) and 95% confidence limits. Postexperimental baseline - Po. B.

With few exceptions, each point in these tables which varies outside the 95% confidence limits has been associated with severe loss in environmental control, e. g., equipment failure, power loss, and chamber pressure changes. While it cannot be readily inferred from these data whether there are subtle behavioral effects of 100% oxygen at 5 psia, the fact that each point of statistically significant departure from predicted limits has occurred during moments of unprogrammed stress permits us some confidence in our original research hypothesis, i. e., the experimental environment would not have a detrimental effect on performance.

No definite hematological changes could be observed (table IV).

TABLE IV
HEMATOLOGY AND BLOOD CHEMISTRY

	Pr. B.	II	Week			Po. B.
			IV	VIII	XIII*	
Hematocrit	37.5	36.6	34.7	34.8	37.3	33.5
Hemoglobin	11.6	11.3	10.3	11.1	11.6	10.8
RBC	5.16	5.07	4.84	4.87	5.23	4.82
WBC	10.4	11.0	11.4	10.5	12.5	8.6
Neutrophiles	29.9	32.2	31.4	31.4	43.2	-
Lymphocytes	61.2	60.1	61.6	61.2	47.9	-
Bands	2.6	1.6	0.4	0.0	0.7	-
Monocytes	0.1	1.5	0.5	2.8	2.0	0.8
Eosinophiles	6.2	4.6	6.1	4.2	6.2	5.6
Sed. Rate	0.6	1.2	0.3	1.2	2.0	6.5
Sodium	152.0	150.2	151.8	148.6	144.2	143.4
Potassium	5.5	5.9	5.4	5.1	4.3	4.5
Calcium	5.4	5.8	5.8	6.3	5.6	5.6
Total Protein	7.8	7.9	7.4	7.4	8.4	7.7
Albumin/Globulin	4.9	4.8	4.8	4.5	4.8	4.3
SGPT	99.	98.	87.	108.	90.	46.
SGOT	77.	88.	78.	82.	42.	49.
Alk. Phosphatase	13.2	9.5	8.4	9.3	10.6	14.8
Total Phosphorus	4.6	4.8	4.6	3.7	3.4	4.1
Total LDH	560.	632.	822.	778.	720.	632.
BUN	18.2	18.9	20.2	17.9	18.2	15.9

*A: /60 mm ambient

Again, however, there were complicating circumstances which caused difficulty in interpreting the trends in blood values. The transportation of the trained subjects from an altitude of 4,300 feet in New Mexico to 983 feet in Ohio was reflected by a considerable drop in red cells (5.3%), hematocrit (12.5%), and hemoglobin (13.4%). These changes were seen in all subjects after their arrival in Ohio and within 10 days of their last bleeding in New Mexico, and no subject showed a rise in these values. Because of these "physiological adaptations" to altitude changes, the physiological baseline data obtained in New Mexico were discarded. Only slight changes were observed in any of the cellular components of the blood during

the experimental phase of the study, which closely agrees with the findings of Zaluske and co-workers (ref 21). Sodium and potassium showed gradual downward trends which were exhibited by all subjects. Blood calcium rose slightly over the 90 days at altitude. Transaminase values reflected the numerous "stressful" events which occurred during the study and are generally elevated over baseline values throughout the study, returning to slightly below baseline at the postbaseline analysis.

Alkaline phosphatase, total phosphorus, total LDH, and BUN were too variable to detect any trends.

CONCLUSIONS

On the basis of the experimental findings it may reasonably be concluded that:

1. Subhuman primates do not exhibit performance changes of any serious consequence when exposed to 100% oxygen at 5 psia for 3 months.
2. Performance decrements which were detected were generally closely associated with loss of environmental control or apparatus malfunctioning.
3. Measures of auditory functioning can be made only when noise within the experimental situation is sufficiently low or masked to preclude interference with the signal to the subject. Otherwise, proper inferences concerning the integrity of the auditory sense modality cannot be made.
4. Proper controls over the environment and experimental apparatus must be planned for and accomplished if the reliability and validity of performance measures is to be achieved. This will insure that future experiments of this variety will yield the best possible results for purposes of extrapolation and application.

REFERENCES

1. Bert, Paul. La Pression Barometrique (1878). English Translation, M. A. Hitchcock and F. A. Hitchcock, Columbus, Ohio, College Book Company, 1943.
2. Bean, V. W. Effects of Oxygen of Increased Pressure. Physiol. Review 25: 1, 1945.
3. Smith, J. L. (1899). The Pathological Effects Due to Increase of Oxygen Tension in the Air Breathed. J. Physiol., 24, 19-35.
4. Thompson, W. A. R. (1935). The Physiology of Deep-Sea Diving. British Med. J. ii, 208.
5. Behnke, A. R., Forbes, H. S., and Motley, E. P. (1935). Circulatory and Visual Effects of Oxygen at 3 atm Pressure. Am. J. Physiol. 144, 436-442.
6. Behnke, A. R., Johnson, F. S., Poppen, J. R., and Motley, E. P. (1935). The Effect of Oxygen on Man at Pressures from 1-4 atm. Am. J. Physiol. 110, 565.
7. Morgan, Thomas E., Jr., Capt. USAF, MC, Ulvedal, F., Cutler, R. G., and Welch, B. E. Effects on Man of Prolonged Exposure to Oxygen at a Total Pressure of 190 mm Hg. Aerospace Med., Vol. 34, No. 7, July 1963.
8. Davidson, B. J. Pharmacol. 26, 111, 1926.
9. Shilling, C. W., and Willgrube, W. W. U. S. Naval Med. Bull. 35, 373, 1937.
10. Hill, L., and Phillips, A. E. J. Roy. Naval Med. Serv., 18, 157, 1932.
11. Harris, J. G., Reischer, D. E., and Everson, D. (1960). The Effects of Inhalation of 100% Oxygen on Performance of a Task Involving Auditory Conflict. Bureau of Med. & Surgery Project MR. 005, 13-1002, Subtask II, Report 3, USN School of Aviation Medicine, Pensacola, Fla.
12. Eechler, C. C., Newton, N. L., Culver, J. F., and Tredici, T. (1963). Occular Hyperoxia. Aerospace Med. 34, 1017-1020.
13. Gordon, H. H., Lubchenco, L., and Hix, L. (1954). Observations on the Aetiology of Retrolental Fibrophasia. Bull. Johns Hopkins Hosp. 94, 34.
14. Morgan, Thomas E., Jr. M.D., Cutler, R. E., Shaw, E. G., Ulvedal, F., Hargreaves, J. J., Moyer, J. E., McKenzie, R. E., and Welch, B. E. Physiological Effects of Exposure to Increased Oxygen Tension at 5 psia. Aerospace Med. Vol. 34, No. 8, Aug. 1963.
15. Hartman, B. O., McKenzie, R. E., and Welch, B. E. Performance Effects in 17-day Simulated Space Flights. Aerospace Med., 33: 1098, 1962.

REFERENCES (cont'd)

16. McKenzie, R. E., Hartman, B. O., and Welch, B. E. Observations in the SAM Two-Man Space Cabin Simulator. III Systems Operator Performance Factors. Aerospace Med. 32: 603, 1961.
17. Reynolds, H. H., Gilbert, G. A., Bogo, V., and Barnhart, G. T. Chimpanzee Performance During Eight Days of Simulated Orbital Flight. Tech. Doc. No. ARL-TDR 64-2, Aeromedical Research Laboratory, Holloman Air Force Base, New Mexico, Feb. 1964.
18. Farrer, D. N., Bogo, V. Chimpanzee Performance During a Simulated Three-Day Space Flight. Tech. Doc. Rept. No. ARL-TDR 62-25, Dec. 1962.
19. Thomas, Anthony A., M.D. "Chamber Equipment Design Considerations for Altitude Exposures." In Proceedings of the Conference on Atmospheric Contamination in Confined Spaces, AMRL-TR 65-230, Aerospace Medical Research Laboratories, Wright-Patterson Air Force Base, Ohio, pp 9-17 Apr. 1965.
20. Reynolds, H. H., and Back, Kenneth C. Effect of Decaborane Injection on Operant Behavior of Monkeys. Toxicology and Applied Pharmacology, Vol. No. 2, Mar. 1966.
21. Zaluske, R., Ulvedal, F., Herlocker, J. E., and Welch, B. E. Physiological Response to Increased Oxygen Partial Pressure III. Hematopoiesis. Aer Med. 35, 622-626, 1964.

DISCUSSION

FROM THE FLOOR: I'd like to know if you saw any difference between the mulatta and the irus?

CAPT. WOLFLE: I must admit we did not analyze the differences in this study. I intend to when I go back and look at some of the other data. The laboratory has not found classical differences between them, although they have used them in other studies together.

OXYGEN EFFECT ON CONTAMINANT TOXICITY

Co-Chairmen

Dr. Edward J. Fairchild
Division of Occupational Health
U. S. Public Health Service
Cincinnati, Ohio

Dr. Paul Gross
Industrial Hygiene Foundation of
America, Inc.
Mellon Institute
Pittsburgh, Pennsylvania

COMPARATIVE TOXICITY STUDIES ON ANIMALS EXPOSED CONTINUOUSLY
FOR PERIODS UP TO 90 DAYS TO NO₂, O₃, AND CCl₄
IN AMBIENT AIR VS. 5 PSIA 100% OXYGEN ATMOSPHERE

James D. MacEwen, Ph. D.
Robert P. Geckler, Ph. D.

Aerojet-General Corporation
Wright-Patterson Air Force Base, Ohio

INTRODUCTION

One of the objectives of the inhalation toxicology research program of the Air Force is the evaluation of the response of animals to toxic materials administered under conditions of reduced pressure and varying partial pressures of oxygen. The data gathered under these conditions are directly applicable to manned space flight programs, wherein they may be used in the definition of contaminant tolerance levels and acceptable atmospheres for space cabins enduring prolonged flights.

Prior to the advent of manned space flight, there was little demand for information on continuous exposures to low concentrations of atmosphere contaminant materials (ref 1, 2). Stokinger (ref 3) discussed the now very apparent necessity for developing methods by which data obtained in an industrial setting may be extrapolated to the conditions extant in space cabins. He identified seven factors which might be expected to change industrial threshold limit values (TLV) for application to space flight. Stokinger's extrapolated equation is given below.

$$TLV_{space} = \frac{TLV_{ind} \times F_{press}}{F_{cont} \times F_{temp} \times F_{rm} \times F_{O_2} \times F_{fat} \times F^*_{int}}$$

where

- F_{press} = Dosage factor from ambient pressure change to 5 psi = 3
- F_{cont} = Toxicity factor from continuous dosage = 1 to 4
- F_{temp} = Toxicity factor from temperature change, F_{ΔT}
- F_{rm} = Toxicity factor due to restricted motion, F_{ΔM}
- F_{O₂} = Toxicity due to 100% O₂ at 5 psi
- F_{fat} = Toxicity factor due to fatigue, F_{ΔF}
- F^{*}_{int} = Toxicity factor from interaction

He further emphasized the need for investigations which will quantify the influence of the seven factors so that data obtained from discontinuous exposures can be used

in manned space programs. In the experiments about to be discussed, three of the factors described by Stokinger (ref 3) received attention, namely, oxygen atmosphere, reduced pressure, and continuous exposure: beagle dogs, rhesus monkeys, mice, and rats (and in one case, guinea pigs) were subjected to continuous exposure of TLV concentrations of nitrogen dioxide, ozone, and carbon tetrachloride for periods of 90 days in both 100% oxygen at 260 mm Hg and air at 720-740 mm pressure. These three compounds were logical choices for investigation because of the wealth of toxicological data available for them and their mechanisms of action; ozone and nitrogen dioxide are recognized pulmonary irritants and carbon tetrachloride is a systemic poison.

The basis and justification of this series of investigations are the results of 2-week continuous studies, reported at the first Conference on Atmospheric Contamination in Confined Spaces (ref 4), with the same contaminants at varying concentrations. Although the subject of this paper is primarily the 90-day exposure, the data of the 2-week experiments will be briefly reviewed for coordination with the pathology results to be presented in a subsequent paper in this report.

MATERIALS AND METHODS

Animal exposure facilities (ref 5) of the Aerospace Medical Research Laboratories were used for the 90-day continuous experiments being reported. To reiterate, the atmosphere compositions were 100% oxygen at 260 mm Hg pressure and air at either 720 ($p_{O_2} = 154$ mm Hg) or 740 mm Hg ($p_{O_2} = 148$ mm Hg) pressure. Contaminant concentrations used were nominally the TLV for human normal industrial exposures. The actual exposure concentrations for ozone were 0.19 mg/M³; for nitrogen dioxide, 9.3 mg/M³; and for carbon tetrachloride, 63 mg/M³. Ozone was generated by a Welsbach Silent Discharge Generator. The nitrogen dioxide and carbon tetrachloride were reagent grade chemicals obtained from commercial sources.

As mentioned above, the experimental animals included beagle dogs, rhesus monkeys, rats, mice, and guinea pigs. The beagles, obtained from commercial sources, weighed 6-7 kg; the monkeys, 3-4 kg. The weight of the rats varied from 125 to 150 g and that of the mice from 20 to 25 g. The guinea pigs, used only in the ozone experiment, weighed approximately 250 g. All animals received routine inspection and were quarantined before initiation of the experiments; appropriate baseline data were obtained for all experimental subjects.

During the course of an experiment, all animals are observed at 30-minute intervals for effects of contaminant exposure; upon dying, animals are removed from the exposure chamber immediately for postmortem examination and tissue sampling. Clinical blood determinations for the beagle dogs and rhesus monkeys are done on a biweekly basis. For rats, these determinations are made and compared with control values at the time of sacrifice. Clinical chemistry analyses include the following: hematocrit, hemoglobin, red blood cell count, white blood cell count, sodium, potassium, calcium, total protein, albumin, SGOT, SGPT, alkaline phosphatase, total phosphorus and LDH.

In addition to these analyses, tissue samples for histopathological examination are taken at the time of death or sacrifice. At the time of this report, the

histopathological data for the 90-day exposures are not available. Organ weights for beagles, monkeys, and rats are determined for each experiment; of particular interest in the O₃ and NO₂ exposures is the lung to body weight ratio and, in the CCl₄ exposures, the liver to body weight ratio.

EXPERIMENTAL RESULTS

REVIEW OF TWO-WEEK CONTINUOUS EXPOSURES

Mortality during 2-week continuous exposures to NO₂, O₃, and CCl₄ is presented in tables I, II, and III, respectively. There is some indication in the NO₂ data (table I) that mortality is less at reduced pressure than at 700 mm Hg pressure. Since, however, the 700 mm Hg pressure gas mixture is air ($p_{O_2} = 140$ mm Hg) and the 260 mm Hg pressure atmosphere is 100% oxygen, it cannot be determined from this comparison if mortality variation is due to either oxygen tension or total pressure. The possible protective effect of increased oxygen partial pressure will be discussed in a later paper in this report.

Ozone gave results similar to NO₂ (table II); less mortality occurred in those groups subjected to 100% oxygen, reduced pressure atmosphere than in those subjected to ambient air.

Table III reveals only rat and mice deaths in the exposures to CCl₄. As discussed elsewhere (ref 4, 6), the rat mortality may be attributed to strain differences in response to reduced pressure. In the highest CCl₄ concentration exposure of mice, there is a difference between the two groups. However, there does not appear to be any protective effect in 100% oxygen, 5 psia experiment such as was seen in the O₃ and NO₂ exposures shown in previous tables.

Table IV contains data on blood enzymes of dogs and monkeys exposed for 2 weeks to CCl₄. The three enzymes measured all showed considerable increase over normal values. However, no clear-cut differences due to low pressure environment are evident from this table.

An analysis of organ to body weight data of this series reveals the effect of ozone on the lung to body weight ratios in rats, dogs, and monkeys. These data, in table V, indicate a direct dose response relationship over a wide range of exposures. In the case of NO₂ exposures, no such relationship was obtained, the response being relatively uniform and apparently unrelated to dose.

90-DAY CONTINUOUS EXPOSURE RESULTS

The mortality results of the 90-day continuous exposures to TLV for O₃, NO₂, and CCl₄ are detailed in table VI. The data are unremarkable except for the deaths at 720 mm Hg pressure in the ozone exposures. Mice appear somewhat more sensitive to ozone than the other three species. Guinea pigs also showed mortality upon exposure to ozone, which was the only material to which this species was exposed. Note that most of the deaths occurred during the first half of the 90-day exposure suggesting some degree of adaptation in the survivors.

Mortality is, of course, too severe an endpoint to consider using for practical applications. For this reason, it is important to look into the subtle effects as they may be reflected in changes in the clinical chemistry and pathology of the animals. Clinical information from dogs obtained in the 90-day experiments is listed in table VII. Hematocrit, hemoglobin, red and white blood cell counts, and the electrolytes, sodium, potassium, and calcium are shown. These data represent mean values of biweekly determinations for exposed animals (columns 1 and 2) as well as control animals (column 3) taken over the course of the experiment. All of the data in this table are within normal values and there is no reason to suspect any changes. Table VIII shows similar data on monkeys; again, the data are within normal ranges. Tables IX and X present mean values for total protein, albumin, SGPT, SGOT, alkaline phosphatase, total phosphorus, and LDH for dogs and monkeys, respectively.

In dogs, SGPT and SGOT responses were similar for all contaminants, a slight rise being observed in exposed animals. However, in monkeys, SGPT shows a difference only for NO_2 and CCl_4 ; SGOT responses were not clearly discernible in the monkey species. The control animals showed values somewhat higher than might be expected although they were still within the normal range.

The values for clinical determinations are mean values calculated from all test values obtained biweekly over the total experiment period (except for rat data). Differences could appear temporarily during the course of the experiment which would not be obvious when only the means were compared. For this reason, the biweekly mean values of the SGOT and SGPT, the only clinical chemistry measurements showing variation between experimental groups, are graphically presented over the 90-day period. Figures 2 through 7 present these data from dogs; lack of time prevents consideration of data for these measurements from monkeys.

In figures 1, 2, and 3, the SGOT data are plotted for NO_2 , CCl_4 , and O_3 exposures, respectively. In figure 1, the data from exposed animals exceeded those of the controls at each determination except the initial and final one; from analysis of figure 2, it can generally be said that the values for the exposed animals again exceeded their controls; and, finally, in figure 3, the exposed animal data, although more variable, exceed the controls in most cases. SGPT values show much the same trend, as may be determined from examination of figures 4, 5, and 6. Qualitatively, it may be said that, though the means of all the data taken during the 90-day period do not show statistically significant differences, there may well be differences during the course of the experiment in SGOT and SGPT values. The data are consistent with the hypothesis that the animals first respond to the atmospheric contaminant and then adapt to the changed environment. The data do not, however, reveal significant differences between those animals exposed to contaminants at reduced pressure in 100% oxygen and those exposed at normal atmospheric pressure (740 mm Hg).

Rat data taken at sacrifice at the end of the experiment showed significant differences in four instances between the controls and those animals exposed to the TLV of CCl_4 ; LDH, SGPT, SGOT, and alkaline phosphatase were all significantly higher. These data are shown in table XI. The greater susceptibility of rodents, as compared with dogs and monkeys, to the effects of CCl_4 seen in the two 90-day experiments was consistent with the mortality results of the 2-week studies at a higher CCl_4 concentration (594 mg/M^3) previously reported. In this CCl_4 exposu

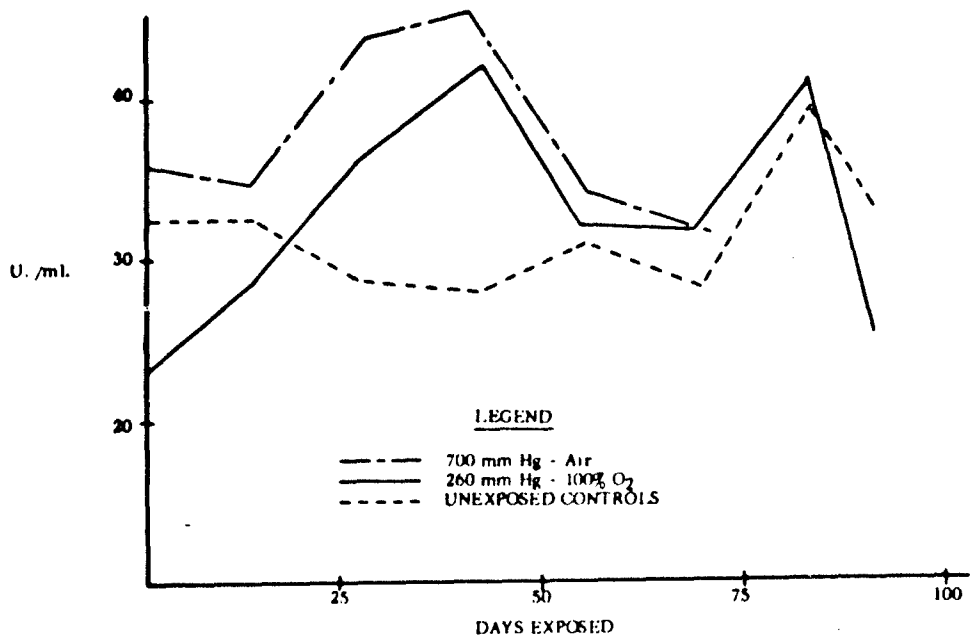

Figure 1. EFFECT OF $9.3 \text{ mg/M}^3 \text{ NO}_2$ 90-DAY CONTINUOUS INHALATION EXPOSURE ON BEAGLE DOGS SERUM SGOT LEVEL

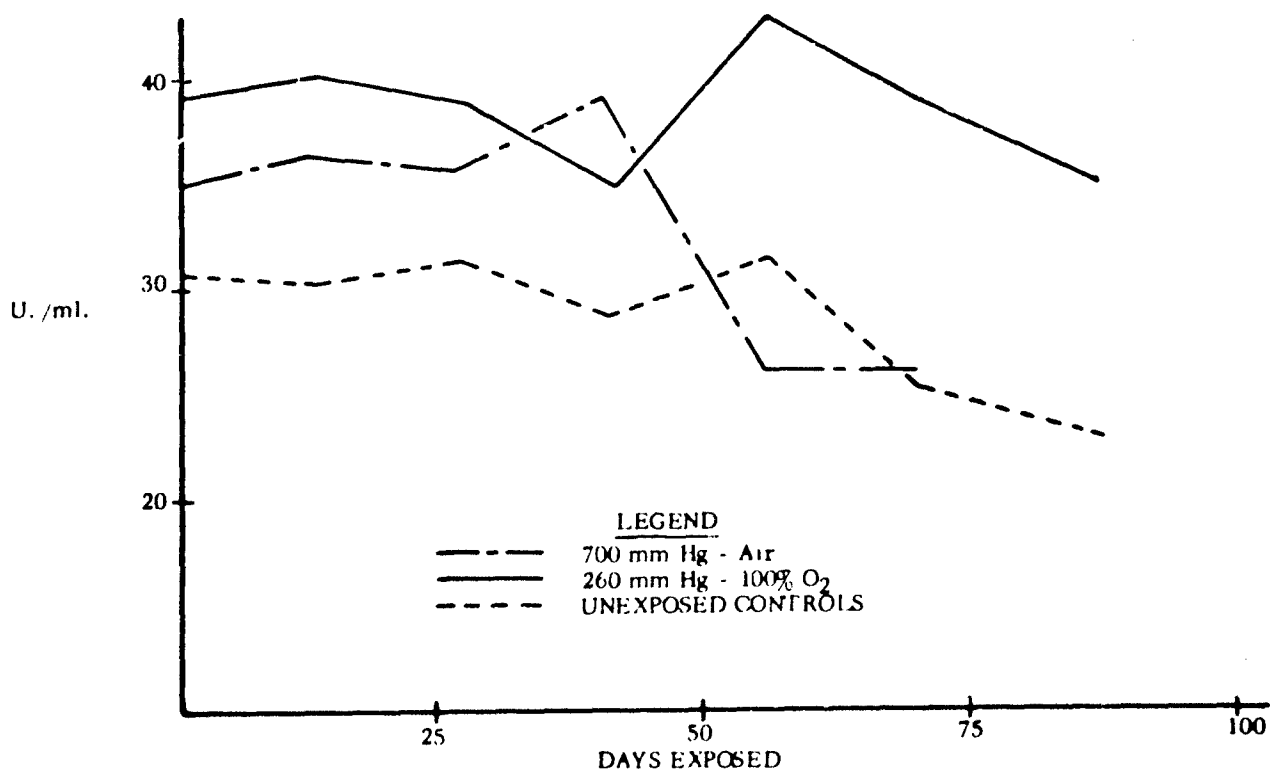

Figure 2. EFFECT OF $63 \text{ mg/M}^3 \text{ CCl}_4$ 90-DAY CONTINUOUS INHALATION EXPOSURE ON BEAGLE DOGS SERUM SGOT LEVEL

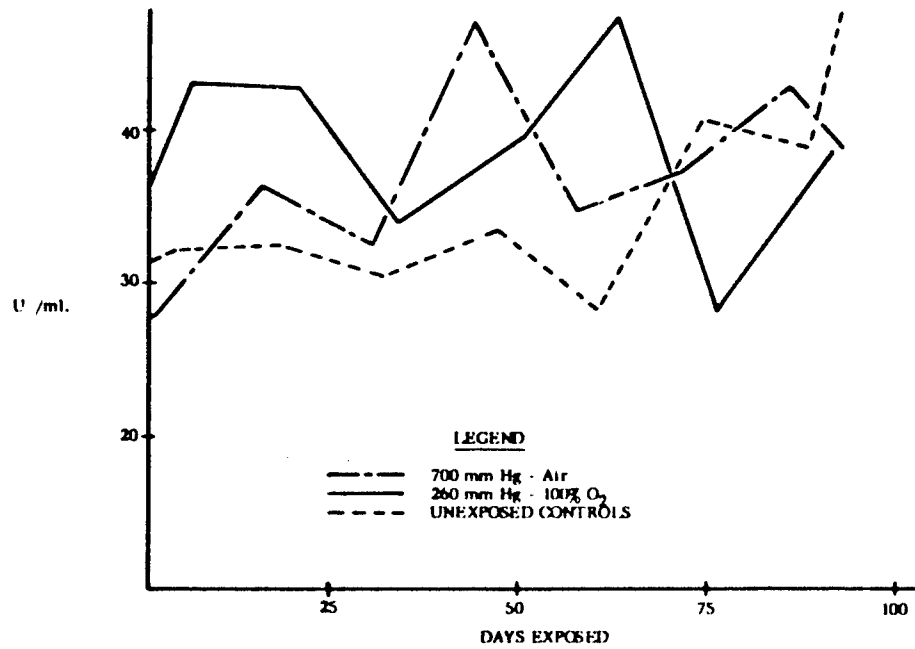

Figure 3. EFFECT OF 0.19 mg/M³ O₃ 90-DAY CONTINUOUS INHALATION EXPC ON BEAGLE DOGS SERUM SGOT LEVEL

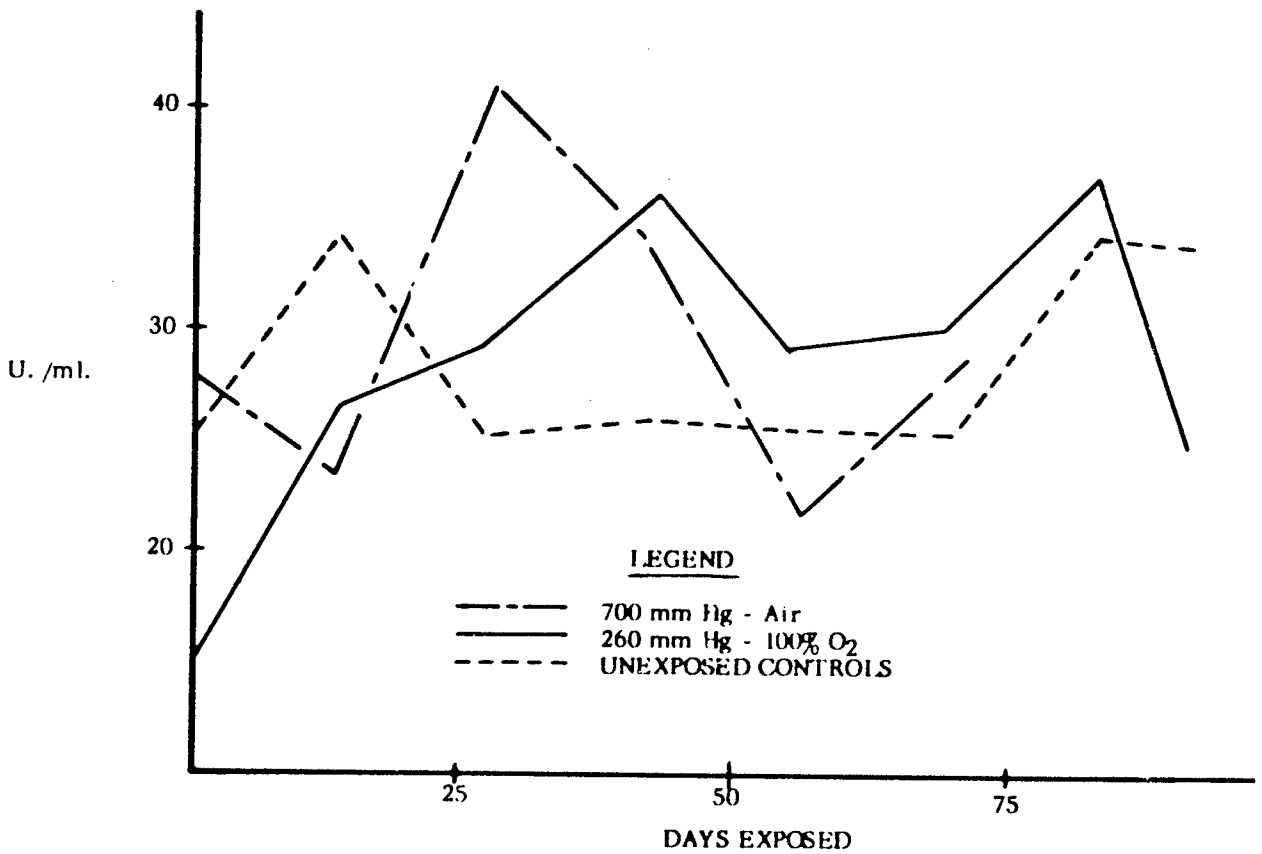

Figure 4. EFFECT OF 9.3 mg/M³ NO₂ 90-DAY CONTINUOUS INHALATION EXPC ON BEAGLE DOGS SERUM SGPT LEVEL

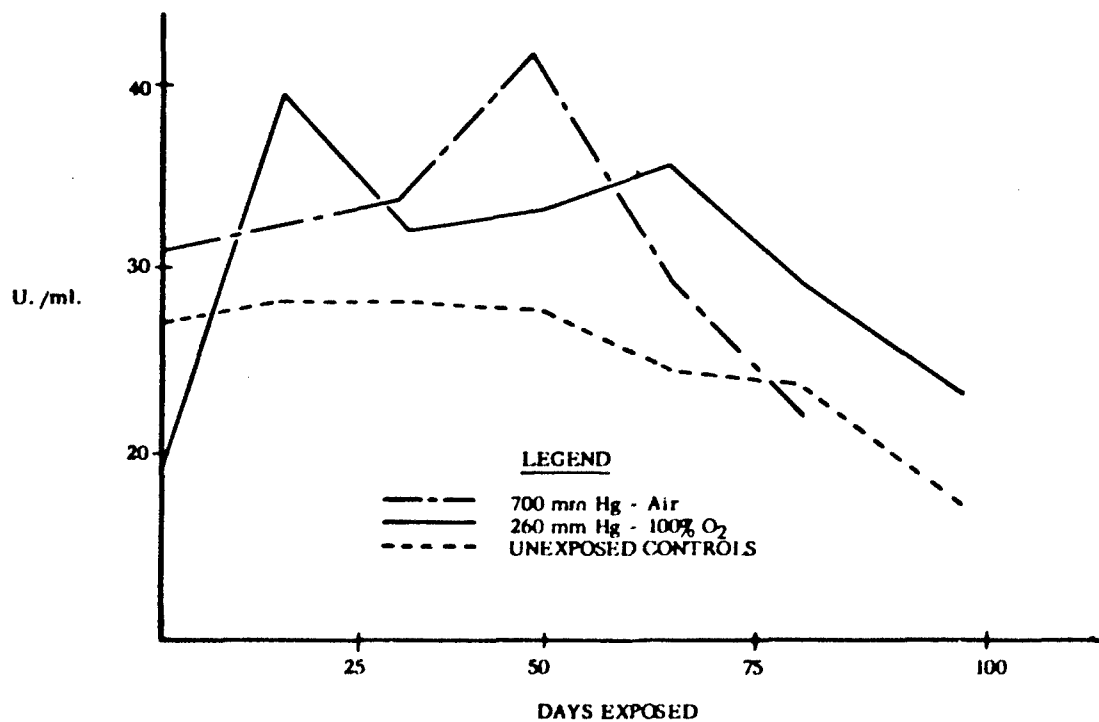

Figure 5. EFFECT OF $63 \text{ mg/M}^3 \text{ CCl}_4$ 90-DAY CONTINUOUS INHALATION EXPOSURE ON BEAGLE DOGS SERUM SGPI LEVEL

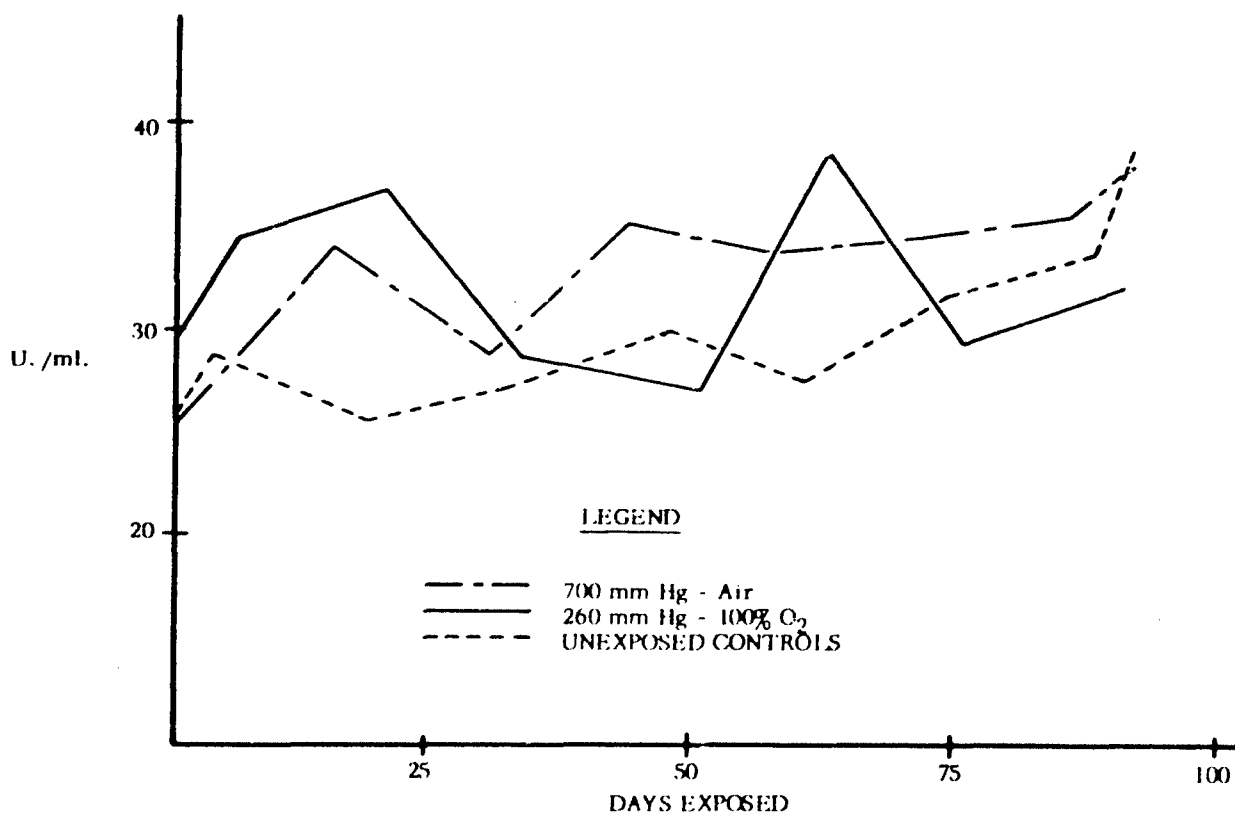

Figure 6. EFFECT OF $0.19 \text{ mg/M}^3 \text{ O}_3$ 90-DAY CONTINUOUS INHALATION EXPOSURE ON BEAGLE DOGS SERUM SGPT LEVEL

rats showed a significant (at the 1% level) difference in the liver to body weight ratio. This ratio was also higher in the exposed dogs, but because of the small number of animals statistical significance could not be demonstrated. At necropsy all species showed gross changes in liver tissue. Frozen sections were prepared and fat stains made on these sections revealed fatty disposition in the liver of all tested which was considerably greater in those animals exposed to CCl_4 under test conditions.

DISCUSSION

The lack of mortality during the 90-day continuous exposures is in marked contrast to the mortality previously published (ref 4, 6) for 2-week continuous exposures at higher concentrations. However, the lung of the one dog which died during the 90-day exposure to ozone showed a typical ozone response: marked diffuse pulmonary hemorrhage and edema, a typical acute response to many pulmonary irritant materials. With respect to the clinical data, although the values for the serum enzymes of exposed animals were different from the control values, no adverse effects on the experimental animals were noted. Perhaps the pathological data will demonstrate significant permanent changes. The natural variability and small differences observed in these enzyme data under discussion make it unwise to draw conclusions on anything but a tentative basis. Obviously, much more work needs to be done to substantiate any conclusions offered.

On the basis of the data obtained, the evidence is reasonably conclusive that for the materials and conditions used in the experiments, the TLV for space conditions may not be radically different from industrial TLV. Some care should be taken in interpreting the foregoing remark. Threshold limit values have classically included a large and sometimes unknown safety factor. Because of the fact that some differences were found, there is a hint that perhaps the safety factor for the TLV for the three materials studied were about to be exceeded. In summarizing, it does appear clear that the TLV for space applications may not be radically different from industrial TLV if only the factors of continuous dosage, reduced pressure, and pure oxygen atmosphere are considered.

TABLE I

MORTALITY -
14-DAY CONTINUOUS EXPOSURE TO NO₂

AGENT	AVG. CONC. (mg/M ³)	ABSOLUTE PRESSURE ' (mm Hg)	MORTALITY BY SPECIES (NO. DEAD/NO. EXPOSED)				
			MONKEYS	DOGS	RATS	MICE	GUINEA PIGS
NO ₂	0	750	-	-	0/40	0/40	-
	0	260	0/4	0/4	0/40	0/40	-
	36	700	4/4	0/5	5/50	2/40	-
	38	260	2/4	0/8	3/50	0/40	-
	89	700	4/4	8/8	50/50	40/40	-
	81	260	4/4	7/8	37/50	40/40	-

TABLE II
MORTALITY -
14-DAY CONTINUOUS EXPOSURE TO O₃

AGENT	AVG. CONC. (mg/M ³)	ABSOLUTE PRESSURE (mm Hg)	MORTALITY BY SPECIES (NO. DEAD/NO. EXPOSED)				
			MONKEYS	DOGS	RATS	MICE	GUINEA PIGS
O ₃	0	750	-	-	0/50	0/40	0/8
	0	260	0/4	0/4	3/20	3/20	0/8
	8	700	2/4	5/5	50/50	34/40	8/8
	8	260	0/4	2/8	45/50	33/40	8/8
	15	700	1/4	8/8	50/50	40/40	8/8
	15	260	0/4	6/8	-	-	-

TABLE III
MORTALITY -
14-DAY CONTINUOUS EXPOSURE TO CCl₄

AGENT	AVG. CONC. (mg/M ³)	ABSOLUTE PRESSURE (mm Hg)	MORTALITY BY SPECIES (NO. DEAD/NO. EXPOSED)				
			MONKEYS	DOGS	RATS	MICE	GUINEA PIGS
CCl ₄	0	750	-	-	0/40	0/40	-
	0	260	0/2	0/2	8/40*	0/40	-
	35	700	0/4	0/6	0/50	0/40	-
	32	260	0/4	0/8	8/50*	0/40	-
	576	700	0/4	0/8	0/50	2/40	-
	594	260	0/4	0/8	0/50	39/40	-

*Due to poor tolerance of Wistar strain rats to reduced-pressure parameters

TABLE IV

EFFECT OF 14-DAY CONTINUOUS "HIGH-LEVEL" CCl₄ EXPOSURES ON THE
 SGPT, SGOT AND ALKALINE PHOSPHATASE LEVELS IN LABORATORY ANIMALS
 ALTITUDE VS. AMBIENT CONDITIONS

CONDITIONS	CONC. (mg/M ³)	SGPT (MEAN + RANGE)	SGOT (MEAN + RANGE)	ALK. PHOS. (MEAN + RANGE)
<u>MALE BEAGLES</u>				
ALTITUDE	594	324 (250-465)	115 (95-150)	24 (14-34)
AMBIENT	577	461 (300-818)	94 (74-135)	12 (7-21)
<u>FEMALE BEAGLES</u>				
ALTITUDE	594	503 (290-680)	127 (108-170)	21 (10-27)
AMBIENT	577	539 (348-818)	106 (74-150)	11 (6-18)
<u>MONKEYS</u>				
ALTITUDE	594	127 (39-250)	49 (40-64)	26 (20-34)
AMBIENT	577	44 (30-60)	54 (45-64)	28 (26-33)

TABLE V
 EFFECT OF OZONE ON LUNG WEIGHTS
 (14-DAY CONTINUOUS EXPOSURE 100% O₂, 5 PSIA)

Conc. (mg/M ³)	Lung Weight (wet)/Body Weight Ratios				
	Rat (mg/gm)		Beagle (gm/kg)		Monkey (gm/kg)
	Male	Female	Male	Female	Female
1.9	8	9	10	12	8
4.2	12	10	15	12	7
8.0	21	24	29	20	10
15.4	--	--	34	--	14

TABLE VI
 COMPARATIVE TOXICITY STUDIES
 AT REDUCED AND AMBIENT PRESSURES
 CHRONIC EXPOSURE
 MORTALITY
 (NO. DEATHS/NO. EXPOSED)

AGENT	OZONE		NO ₂		CCl ₄	
CONCENTRATION (mg/M ³)	0.19	0.19 --	9.3	9.3 --	63	62 --
PRESSURE (mm Hg)	260	720 740	260	740 740	260	740 740
ATMOSPHERE COMPOSITION	100% O ₂	Air Air	100% O ₂	Air Air	100% O ₂	Air Air
<u>MORTALITY BY SPECIES</u>						
MICE	2/40	7/40 0/60	2/40	1/40 0/80	1/39	0/40 0/80
RATS	0/50	0/50 1/100	0/50	0/50 0/100	0/50	1/50 3/100
DOGS	0/7	1/8 0/8	0/8	0/8 0/8	0/8	0/8 0/8
MONKEYS	0/4	0/4 0/4	0/4	0/4 0/4	0/4	0/4 0/4
GUINEA PIGS	1/6	4/6 2/7	-	- -	-	- -

TABLE VII

COMPARATIVE TOXICITY STUDIES
AT REDUCED AND AMBIENT PRESSURES
90 DAY - TLV EXPOSURES
CLINICAL DETERMINATIONS
BEAGLE DOGS

AGENT	OZONE		NO ₂		CCl ₄	
CONCENTRATION (mg/M ³)	0.19	0.19	9.3	9.3	63	62
PRESSURE (mm Hg)	260	720	740	740	260	740
ATMOSPHERE COMPOSITION	100% O ₂	Air	Air	100% O ₂	100% O ₂	Air
<u>BLOOD TEST</u>						
HCT (Vol. %)	43	44	46	41	45	45
HGB (gm %)	14.3	15.0	15.4	13.3	15.0	15.1
RBC (x 10 ⁶)	5.7	6.1	6.2	5.7	6.3	6.3
WBC (x 10 ³)	14.0	15.2	14.1	13.0	15.8	14.8
SODIUM (mEq. /l.)	140	145	146	146	143	145
POTASSIUM (mEq./l.)	4.6	5.0	5.0	5.1	4.9	5.0
CALCIUM (mEq./l.)	5.3	5.3	5.4	5.5	5.5	5.7

TABLE VIII
 COMPARATIVE TOXICITY STUDIES
 AT REDUCED AND AMBIENT PRESSURES
 90 DAY - TLV EXPOSURES
 CLINICAL DETERMINATIONS
 MONKEYS

AGENT	OZONE		NO ₂		CCl ₄	
CONCENTRATION (mg/M ³)	0.19	0.19	--	9.3	9.3	--
PRESSURE (mm Hg)	260	720	740	260	740	740
ATMOSPHERE COMPOSITION	100% O ₂	Air	Air	100% O ₂	Air	100% O ₂ Air
<u>BLOOD TEST</u>						
HCT (Vol. %)	38	41	42	37	35	42
HGB (gm %)	11.8	12.7	13.4	11.8	10.9	13.1
RBC (x 10 ⁶)	4.7	5.3	5.2	5.0	5.3	5.6
WBC (x 10 ³)	10.9	10.7	10.2	9.2	9.8	12.3
SODIUM (mEq./l.)	145	148	147	148	145	147
POTASSIUM (mEq./l.)	4.7	4.7	4.8	4.6	4.9	5.1
CALCIUM (mEq./l.)	5.3	5.3	5.4	5.3	5.8	5.6
						42
						62
						740
						100% O ₂ Air
						42
						12.8
						5.5
						12.1
						17.2
						147
						146
						4.7
						4.6
						5.7
						5.7

TABLE IX

COMPARATIVE TOXICITY STUDIES
AT REDUCED AND AMBIENT PRESSURES
90 DAY - TLV EXPOSURES
CLINICAL DETERMINATIONS
BEAGLE DOGS

AGENT	OZONE		NO ₂		CCl ₄		
CONCENTRATION (mg/M ³)	0.19	0.19	9.3	9.3	63	62	--
PRESSURE (mm Hg)	260	720	740	740	260	740	740
ATMOSPHERE COMPOSITION	100% O ₂	Air	Air	100% O ₂	100% O ₂	Air	Air
<u>BLOOD TEST</u>							
TOTAL PROTEIN (gm.%)	5.8	5.7	5.9	6.1	6.0	6.0	5.9
ALBUMIN (gm.%)	3.5	3.4	3.5	3.3	3.5	3.4	3.4
SGPT (U./ml.)	32	33	30	30	28	33	27
SGOT (U./ml.)	38	37	35	38	31	38	29
ALK. P'TASE (U./ml.)	1.5	2.0	1.4	2.0	1.5	0.9	1.2
TOTAL PHOS. (mg%)	5.6	6.7	6.8	6.1	5.9	5.8	5.3
LDH (U./ml.)	259	262	217	302	204	179	223

TABLE X
 COMPARATIVE TOXICITY STUDIES
 AT REDUCED AND AMBIENT PRESSURES
 90 DAY - TLV EXPOSURES
 CLINICAL DETERMINATIONS
 MONKEYS

AGENT	OZONE		NO ₂		CCl ₄	
	0.19	0.19 --	9.3	9.3 --	63	62 --
CONCENTRATION (mg/M ³)	0.19	0.19 --	9.3	9.3 --	63	62 --
PRESSURE (mm Hg)	260	720	740	740	260	740
ATMOSPHERE COMPOSITION	100% O ₂	Air	Air	Air	100% O ₂	Air
<u>BLOOD TEST</u>						
TOTAL PROTEIN (gm.%)	7.5	8.1	8.1	7.2	7.4	7.8
ALBUMIN (gm.%)	4.9	5.0	5.0	4.8	4.6	4.8
SGPT (U./ml.)	31	31	30	28	29	26
SGOT (U./ml.)	50	41	36	40	41	51
ALK. P'TASE (U./ml.)	22	14	18	16	23	21
TOTAL PHOS. (mg%)	5.5	6.0	6.4	5.0	6.0	6.3
LDH (U./ml.)	437	463	352	429	359	384
					266	205
					100% O ₂	Air
					7.5	7.5
					4.5	4.5
					41	51
					47	51
					21	24
					5.6	6.1
					266	205

TABLE XI
 EFFECT OF CARBON TETRACHLORIDE ON
 SERUM ENZYME LEVELS IN ALBINO RATS
 90-DAY CONTINUOUS EXPOSURE - 63 mg/M³ CCl₄
 U. /ml.

<u>SERUM ENZYME</u>	<u>EXPOSED ANIMALS</u>	<u>UNEXPOSED CONTROLS</u>
SGPT	73	30
SGOT	203	79
ALK. P'TASE	35	22
LDH	2653	1060

REFERENCES

1. Sandage, C., Tolerance Criteria for Continuous Inhalation Exposure to T Material. I. Effects on Animals of 90-Day Exposure to Phenol, CCl₄, and Mixture of Indole, Skatole, H₂S, and Methyl Mercaptan. ASD Technical 61-519 (I), Aerospace Medical Research Laboratories, Aeronautical Syst Division, Wright-Patterson Air Force Base, Ohio, October 1961.
2. Back, K. E., C. Sandage, and A. A. Tamas, Development of Space Cabin Tolerance Criteria to Trace Contaminants. Aerospace Med. 33: 1438.
3. Stokinger, H. E., "Validity and Hazards of Extrapolating Threshold Lim Values to Continuous Exposures". In M. Honma and H. J. Crosby (Ed.), Proceedings of a Symposium on Toxicity in the Closed Ecological System 103-123, Lockheed Missiles and Space Co., Research Laboratories, Pal Alto, California, 1963.
4. McNerney, J. M., "Preliminary Results of Toxicity Studies in 5 PSIA 100 Oxygen Environment". In Proceedings of the Conference on Atmospheric Contamination in Confined Spaces, pp. 98-123, AMRL-TR-65-230, Aero Medical Research Laboratories, Wright-Patterson Air Force Base, Ohio December 1965.
5. MacEwen, J. D., Toxic Hazards Research Unit, AMRL Technical Report 65-125, Aerospace Medical Research Laboratories, Wright-Patterson Air Force Base, Ohio, September 1965.
6. McNerney, J. M., and J. D. MacEwen, "Comparative Toxicity Studies at Reduced and Ambient Pressures. I. Acute Response". Am. Ind. Hyg. 26: 568-573, 1965.

DISCUSSION

MR. WAGNER (Division of Occupational Health Service): Your expression "adaptation to experimental conditions" should be strictly in reference to the ozone. I think more specifically we should infer that this is an adaptation to the ozone itself. The tolerance formation is to ozone rather than to other conditions existing in the experimental design.

DR. DANON (Weizmann Institute): I would like to ask if any attempt was made to estimate the capacity of the liver ribosomes to synthesize proteins at the different stages. The question is whether there was a damage done to the protein synthesis mechanism of the liver from the carbon tetrachloride.

DR. MAC EWEN: No, there was no attempt to sacrifice the animals and make enzyme and protein determinations upon the liver during these tests. The number of animals is somewhat limited by the size of the chambers. I think this is a refinement we can go to in further experiments.

DR. MAC FARLAND (Hazleton Laboratories): In an experiment where you expose animals to a concentration of carbon tetrachloride at 5 psia of oxygen and speak of comparing this with the control, what are the control conditions?

DR. GECKLER: All of the controls for both of these 90-day studies were held in the ambient room at normal pressure conditions. We were actually comparing the groups of animals exposed in ambient pressure air to the threshold limit values of these three toxic agents with the groups exposed to the same concentrations in 100% oxygen at 5 psia pressure. I might add that the lung to body weight ratios were wet weight to total body weight. There was orderly progression of increasing body weight in the ozone exposed animals with increasing concentration within the chamber. This we did not find with nitrogen dioxide. There we found somewhat more erratic results, a sort of go, no-go type of response.

DR. FAIRCHILD: There is one point I would like to bring up. We see now that when we reduce pressures, oxygen toxicity is reduced. At least you've shown in these reduced pressure experiments that these irritants are not giving an additive toxicity; you are actually going back in the other direction. The point I wish to bring out is: do we know that we are getting the same amount of material to the target site at reduced pressure? Can the pulmonary physiologist eventually say something about this or can we do something on distribution of particles or using something tagged to see what's going on in the lung?

DR. MAC EWEN: We reported on this last year and perhaps we neglected to mention it this year. The concentrations of contaminants within the chamber were precisely the same and are expressed in terms of mg/M^3 . Now at 5 psia there are less total gas molecules present at the alveolar surface since there are only one-third as many oxygen molecules at 5 psi as air molecules at ambient pressure. There are an equivalent number of nitrogen dioxide, ozone, or carbon tetrachloride molecules in both instances. To accomplish this mechanically in a dynamic gassing system, you have to have in your incoming stream three times as much contaminant in the carrier gas in the reduced pressure experiment to balance out the relative difference. If you take your samples within the dome they come out the same. One

other comment I might make that perhaps wasn't clear, there was a very pronounced species response difference between dogs and monkeys to the two pulmonary irritants, nitrogen dioxide and ozone. The monkey was highly resistant to the ozone concentrations even as high as 4 or 8 mg/M³, but the dog was highly susceptible. The reverse occurred in the nitrogen dioxide experiments. The monkey was extremely susceptible and at reasonably low concentrations 100% mortality was achieved in a few hours. The dog was much more resistant to this material. Rodents are uniformly more susceptible than both of the higher species.

DR. FAIRCHILD: This is a very odd peculiarity which should be looked into.

PATHOLOGICAL EFFECTS OF EXPOSURE TO PULMONARY IRRITANTS
 AT AMBIENT AIR VS. 5 PSIA 100% OXYGEN ATMOSPHERE
 FOR PERIODS UP TO 90 DAYS

R. L. Patrick, M.D.

Laboratory for Experimental Biology
 St. Louis, Missouri

The purpose of this study was to compare the toxic effects of contaminants under conditions of 5 psia (pounds per square inch, absolute) and 100% oxygen and under normal atmospheric conditions. Mortality and pathologic alterations were evaluated in monkeys, rats, and dogs exposed continuously to various concentrations of nitrogen dioxide and ozone for 14 days.

Animals were exposed to these compounds, sacrificed, and examined grossly at the Toxic Hazards Research Unit. Tissues were sent to the Laboratory for Experimental Biology to be examined microscopically.

Table I shows the mortality of rats, dogs and monkeys exposed to ozone for 14 days. All 14 rats exposed to ozone, 8 mg/m³, at ambient conditions died. Ten died during the first day and four during the second day. At altitude (5 psia, 100% oxygen), 10 died the first day and one died on the 3rd, 7th, and 10th days of exposure. Six survived for the 14-day period. Rats that died in each group on the first day showed similar pulmonary changes - edema, congestion, and hemorrhage. No rats surviving in the altitude group showed no changes considered to be related to the exposure. Others showed acute bronchiolitis and organizing bronchopneumonia.

TABLE I
 MORTALITY PRODUCED BY A 14-DAY
 CONTINUOUS EXPOSURE TO OZONE

CONCENTRATION (mg/m ³)	CONDITION	NUMBER DEAD / NUMBER EXPOSED		
		RATS	BEAGLES	MONKEYS
8	Ambient	14/14	5/5	2/4
8	Altitude	13/19	2/8	0/4
15.3	Ambient	-	8/8	1/4
15	Altitude	-	6/8	0/4

All five dogs which were exposed to 8 mg/m^3 ozone died at ambient conditions. Deaths occurred at 1, 2, 3, 4, and 12 days of exposure. At the same concentration only two of eight died in the altitude group. Both died during the first day of exposure. All animals in both groups showed severe pulmonary pathology in the form of acute inflammation. Edema and hemorrhage were prominent in those that died early in both groups. Edema and hemorrhage were less marked in dogs in the altitude group. At the higher concentration, all 8 died in the ambient group and six of eight in the altitude group. There was severe bronchopneumonia in the two survivors.

Mortality was greater in monkeys exposed to ozone at ambient conditions. At the lower concentration inflammatory changes were similar in all animals. The two that died early showed pulmonary edema. At the higher concentration, pulmonary changes in both groups were similar.

Rats exposed to NO_2 (table II) showed greater mortality under ambient than altitude conditions. At the lower concentration there was no essential difference in the survivors of the two groups. At the higher concentration all ten rats in the ambient group died during the first day. Edema and congestion constituted the main findings. Early bronchiolitis was also noted. In the altitude group at the higher concentration 14 of 25 died. Nine died on the second day. No difference was noted in those dying early. The survivors in the altitude group showed more bronchiolitis and pneumonia and less edema than in the ambient group.

TABLE II
MORTALITY PRODUCED BY A 14-DAY
CONTINUOUS EXPOSURE TO NO_2

CONCENTRATION (mg/m^3)	CONDITION	NUMBER DEAD / NUMBER EXPOSED		
		RATS	BEAGLES	MONKEYS
37.8	Ambient	6/16	0/5	4/4
37.6	Altitude	3/17	0/8	2/4
81	Ambient	10/10	8/8	4/4
75	Altitude	15/25	7/8	4/4

All dogs exposed to NO_2 survived in both groups at the lower concentration. All animals except one in the altitude group showed bronchiolitis or bronchopneumonia. At the higher concentration only one animal survived. This animal was in the altitude group and showed only a mild bronchiolitis. Otherwise, no difference was noted in pathologic alterations in the two groups.

All monkeys in both groups exposed to the higher level of NO₂ died. Patho- alterations in each group were similar. At the lower concentration all four als in the ambient group died during the first day. At altitude the two that died ed alveolar hemorrhage, edema and inflammatory changes similar to that noted : ambient group. Alveolar hemorrhage and edema were not noted in the two vors.

In summary, all three species exposed to two concentrations of NO₂ and ozone ed greater mortality at ambient conditions than at altitude. Animals dying showed similar changes under both conditions. Survivors of each group ed similar changes except in isolated instances. Alveolar hemorrhage and a were the most prominent changes associated with early death. It would seem i psia, 100% oxygen offered some degree of protection against alveolar hemor- : and edema. In some groups inflammatory changes were more marked under de conditions; however, this is thought to reflect the longer survival of this).

DISCUSSION

DR. GROSS: I might say in opening the discussion that the data presented indicate what might be expected of a respiratory irritant administered in fairly large doses. The primary target is the alveolar capillary which responded, as I indicated yesterday, first with exudation of fluid, and if the animal survived several days with the further exudation of cells and exudation of fibrin. It is also of interest that the more extended survivors, presumably a week or more, responded with what Dr. Patrick indicated was an organizing pneumonia which in reality is a response of the alveolar membrane with proliferations of alveolar cells and supporting stroma.

DR. FAIRCHILD: I didn't quite understand - in many instances animals were dying in the chamber and then of course you did your necropsy. In other instances the survivors were sacrificed after the experiment was over. It has been our experience with pulmonary edema that you can get a quite different aspect when you look at the lung immediately after spontaneous death or just before. In other words, there seems to be a much greater development of edema in the very terminal moments just before death. Was there an attempt to correlate these changes here?

DR. PATRICK: I haven't attempted to correlate these specifically, but I think your point is very well made. We have some possible indication that altitude conditions might have some protective effect as far as nitrogen dioxide and ozone are concerned. I think to nail down what this might be though, a group of animals would have to be killed on the first or the second day so that one could compare them at the same time during the experiment and under the same conditions.

DR. GROSS: I would like to discuss Dr. Fairchild's comments a little bit; that is, the difference between the lung weights of animals that have died and animals that were sacrificed even though the exposure was the same. This difference, I believe, is to be sought in the fact that in the animals that died the pulmonary edema and hemorrhage caused the death of the animals. In other words, the pulmonary edema and hemorrhage reached its ultimate in those animals that died, whereas this progressive extravasation of fluid and blood into the lung was cut short by the deliberate killing of the animals for the purpose of sampling.

DR. FAIRCHILD: Very often in a given group of exposed animals some die immediately, some later, and some still later. You'll find often that the animals dying early have very little pulmonary edema, at least in the case of ozone and perhaps phosgene. So I don't quite agree with the last comment. In other words, the animal can go on and on and it keeps developing edema, but those which die very early have very little edema. You have some other processes at work perhaps.

DR. VORWALD (Wayne State University): There is a great variation in the way animals respond and this is one of the great problems not only in experimental research with a biological system but also in human studies, and if this were not true, I think many of our problems would be much simpler than what they are at the present time.

DR. MAC EWEN (Aerojet-General Corporation): I might further elaborate is just slightly. When the animal dies immediately there is an appearance of shock reaction that goes along with it. The animals, particularly the monkeys exposed with ozone, all showed this shock reaction in the first 24 hours. They did reach a tolerance point and recovered rather rapidly and became normal in appearance within 48 to 72 hours. In the nitrogen dioxide experiments we occasionally saw dogs which looked very bad the first 24 hours and then went back to completely normal reactions within another day or so. I think it's really a shock mechanism with early death and that's why you don't see as much as a or hemorrhage.

DR. FAIRCHILD: That's really what I was getting to. I just meant to say we should look at other causes besides the pulmonary edema. We have recent experiments with whooping cough vaccine. We can produce tremendous amounts of pulmonary edema in rats, but if this vaccine has been heated and the adjuvant sensitizing factor is destroyed, you have the edema but you have no death because there's no shock effect. This is the point I wanted to bring out.

COMPARATIVE PATHOLOGY OF ANIMALS EXPOSED TO CARBON TETRACHLORIDE AT AMBIENT AIR VS. 5 PSIA 100% OXYGEN ATMOSPHERE

David T. Harper, Jr., Captain, MC, USAF
Farrel R. Robinson, Major, VC, USAF

Aerospace Medical Research Laboratories
Wright-Patterson Air Force Base, Ohio

INTRODUCTION

Carbon tetrachloride, a well-known metabolic poison, was used as a contaminant in a series of 2-week animal exposures in atmospheres of 100% oxygen at 258 mm Hg (5 psia) and air at 700 mm Hg.

The implications of these studies are twofold. First, the effect of alterations of atmospheric composition on the toxic properties of this specific systemic agent may well be applicable to other possible contaminants in confined systems. Second, recent biochemical findings pertaining to carbon tetrachloride toxicity suggest that an atmosphere containing a high partial pressure of oxygen would exert a synergistic effect with this agent. Conversely, the experimental proof of this synergy would lend credibility to recently proposed theories of action of this toxic agent.

METHOD

General experimental procedures and altitude chamber operation have been discussed earlier (ref 1, 2). Young male and female beagle dogs, *Macaca mulatta* monkeys, Wistar and SPF Sprague-Dawley rats, and male Harlan ICR mice (table I), after baseline studies and 1-3 day preconditioning periods in the chamber at ambient conditions, were either exposed to a purge of 100% oxygen and then elevated slowly over 1.5 hours to a simulated altitude of 27,500 feet (258 mm Hg), or else elevated only slightly to a pressure of 700 mm Hg in air. The 870 cubic foot chamber is a dynamic flow system with oxygen or air flows at approximately 20 cfm. The contaminant was fed into the gas supply lines to insure complete mixing in the chamber itself. Exposures were all continuous and of 14 days duration. Daily dome entries by personnel for animal care and retrieval of dead animals did not affect the environment. The environments and concentrations of contaminant were maintained as in table II. Oxygen and carbon dioxide levels were quite well maintained. Carbon tetrachloride levels varied more widely because of technical factors affecting the rate of introduction into the gas supply lines. Continuous analysis of concentrations of oxygen, carbon dioxide, and contaminant was made as specified in the preceding papers (1, 2).

Animals were caged as in other studies. All controls were maintained under similar conditions of caging and sacrificed concurrently. Control animals for exposures at altitude were maintained at 5 psi in 96-98% oxygen and at room conditions in air. Controls for exposures near ambient pressure in air were maintained in room air. Dead animals were retrieved from the chamber immediately, and either necropsied or placed in a refrigerator until necropsy not more than 6 hours later. All surviving animals were sacrificed immediately after the contaminant exposure.

TABLE I

ANIMALS USED IN ALTITUDE CHAMBER DURING EXPOSURES TO
CARBON TETRACHLORIDE AND CONTROL ENVIRONMENTS

<u>Experimental Group</u>	<u>Dogs</u>	<u>Monkeys</u>	<u>Rats</u> <u>Wistar</u>	<u>Mice</u>
psia O ₂ ; CCl ₄ - 13 mg/m ³	8	4	50	40
psia O ₂ ; CCl ₄ - 32 mg/m ³	8	4	50	40
psia O ₂ ; CCl ₄ - 80 mg/m ³	8	4	50	40
psia O ₂ ; Controls	2	2	40	40
Room Air Controls	-	-	50	40
			Sprague- Dawley	
psia O ₂ ; CCl ₄ - 594 mg/m ³	8	4	50	40
psia O ₂ ; Controls	4	6	39	40
Room Air Controls	-	-	50	40
air (700 mm Hg); CCl ₄ - 576 mg/m ³	8	4	50	40
air (700 mm Hg) Controls	5	4	50	40
air (700 mm Hg); CCl ₄ - 35 mg/m ³	6	4	50	40
air (700 mm Hg) Controls	1	4	50	35**

* Held in Animal Room

* 15 Died of Water Deprivation; Remaining 20 used as Controls

Complete necropsies were performed on all dogs and monkeys. Specimens of heart, lungs, liver, spleen, and kidneys were taken from rats and mice and representative sections were retained for microscopic study. Histological specimens were fixed in neutral buffered formalin, dehydrated and embedded in Paraplast*, sectioned and stained with hematoxylin and eosin. Frozen formalin-fixed tissue was stained with Oil Red O for fat (ref 3). Special stains were used on occasion to demonstrate reticular structures.

Scientific Products, Evanston, Illinois

TABLE II

SUMMARY OF 14-DAY CARBON TETRACHLORIDE EXPOSURE SCHEDULES

NOMINAL CONC.	ACTUAL CONC.	TOTAL PRESSURE	O ₂	CO ₂	MORTALITY
mg/m ³	mg/m ³	mm Hg	%	%	
13	8.19-16.38	240-260	95-99	.06-.39	6/50 Wistar Rats
32	26.46-38.43	245-360	95-99	.04-.35	8/50 Wistar Rats
80	47.82-99.35	245-260 ¹	95-99	.04-.47	8/50 Wistar Rats
5 psia O ₂ Controls	---	240-260 ²	95-99	.04-.51	8/40 Wistar Rats
Room Air Controls	---	---	---	---	No Mortality
594	485-690	270 ³	97-99	0-.14	38/40 Mice
5 psia O ₂ Controls	---	270-280 ⁴	95-99	n. a.	1/40 Mice
Room Air Controls	---	---	---	---	No Mortality
576	416-653	690-700	---	.05-.38	4/40 Mice
Air (700 mm Hg) Controls	---	n. a.	---	---	No Mortality
35	25.4-40.3	700	---	.14-2.2	No Mortality
Air (700 mm Hg) Controls	---	690-760	---	.07-.22	(15/35 Mice) ⁵

- 1) Recomp to 760 mm Hg Day 13
- 2) Recomp to 740 mm Hg Day 4
- 3) Recomp to 520 mm Hg Day 14
- 4) Recomp to 520 mm Hg Day 14
- 5) Water Deprivation

RESULTS

Mortality

No dogs or monkeys died after any exposure (table II). Deaths among rats were confined to the Wistar strain used in the initial series of altitude exposures and altitude controls. Mortality was 6/50 rats at 13 mg/m³ CCl₄, 8/50 at 32 mg/m³ CCl₄, 8/50 at 80 mg/m³ CCl₄, and 8/40 in the altitude control group at 5 psia, 100% oxygen. Death in this strain at altitude has been discussed in another paper (ref 2) and because of the lack of mortality among rats in CCl₄ at much higher concentrations later in this program, this agent was not thought to be important in the etiology. At 594 mg/m³ CCl₄ 38/40 mice died and in the altitude control group for this exposure 1/40 mice died. Four of 40 mice died at 576 mg/m³ CCl₄ in air at 700 mm Hg and 15/35 mice died in the 700 mm Hg air control environment for the 35 mg/m³ CCl₄ exposure. The last group was deprived of water because of an equipment malfunction and cannot be considered to have died because of exposure to air at this pressure.

Pathology

Dogs: Bronchiolar smooth muscle hypertrophy was seen only after exposure to CCl_4 at altitude, whereas alveolar septal widening with influx of mononuclear cells, and hyperplasia and metaplasia of bronchiolar mucosal lining cells were each seen after all CCl_4 exposures and twice among altitude controls.

Gross pallor of the liver (table III) was uniformly present at the two highest concentrations of CCl_4 , but elsewhere was observed only once at 35 mg/m^3 . Scattered fatty vacuoles in liver cells were observed after altitude exposure to lower concentrations of CCl_4 , whereas the high concentrations produced severe hepatic fatty alterations, most marked centrally and obviously distorting the lobular architecture. No vacuoles were noted after exposure to 35 mg/m^3 CCl_4 at ambient. Focal necrosis of liver cells was observed sporadically at the three highest concentrations. Because of variability in staining and fixation, mild cytoplasmic alterations such as clumping of proteinaceous material and eosinophilia which were seen at all concentrations and in some control animals, could not be attributed to exposure.

Of the four species exposed, the dog was the least apt to show stainable liver fat at any given concentration. After exposure to 594 mg/m^3 CCl_4 at altitude four Oil Red O stains were 2, 3, 3, 3, /4+, whereas after exposure to 576 mg/m^3 CCl_4 at ambient three stains were 1, 1, 1/4+. Fat stains at lower concentrations of CCl_4 were negative. Rare instances of fat vacuoles in renal tubules were observed after exposure at altitude.

Pulmonary congestion, hemorrhage and edema, focal atelectasis and emphysema, pneumonia and bronchitis, granulomas and interstitial fibrosis were observed sporadically, often more frequently among controls, and cannot be related to exposure to CCl_4 . Incidence of these pulmonary lesions was higher in the initial series of exposures. Nephritis and pyelitis were quite common, occurring in every group.

Monkeys: Gross pallor (table III) or increased lobular pattern of the liver were observed after all CCl_4 exposures and were more marked at the higher concentrations. The monkey was the species most severely affected by fatty change. Focal vacuoles in liver cells appeared in one animal at 13 mg/m^3 CCl_4 but at all higher concentrations a severe centrilobular fatty change occupying 30-90% of the lobule was seen in every exposed animal. Only one small focal necrosis was seen at 576 mg/m^3 CCl_4 at ambient. All exposed groups of monkeys had stainable fat in liver, this being most marked (3/4+) after the three highest concentrations of CCl_4 at altitude.

Focal pulmonary hemorrhages, lung mite lesions, (Pneumonyssus simicola) pneumonia, bronchitis, interstitial inflammation and fibrosis, tracheitis, atelectasis and emphysema appeared sporadically or among both exposed and control groups, and cannot be related to CCl_4 exposure. Focal hepatic, renal and myocardial inflammation were also noted but felt to be manifestations of enzootic diseases of this species. Pulmonary congestion and edema appeared sporadically but only after exposure to CCl_4 and were more common after exposure at altitude.

TABLE III

PATHOLOGY OF CARBON TETRACHLORIDE EXPOSURES

	13 mg/m ³	32 mg/m ³	80 mg/m ³	Alt. Cont.	Rm. Air Cont.	594 mg/m ³	Alt. Cont.	Rm. Air Cont.	576 mg/m ³	Amb. Cont.	35 mg/m ³	Amb. Cont.
DOGS: Liver Pallor												
Vacuoles	4/8	3/8	3/8			7/8			8/8		1/6	
Severe fatty						2/8						
Focal necrosis			1/8			6/8			9/8			
Oil Red O	0001*	00	000	0		2/8			1/8			
Kidney Fatty vacuoles	1/8	1/8				2333			111		00	
						2/8						
MONKEYS: Liver Pallor												
Inc. lobulation	1/4	1/4	1/4			4/4			4/4		4/4	
Vacuoles	1/4	4/4	1/4			4/4			4/4			
Severe fatty		4/4	4/4			4/4			4/4		4/4	
Focal necrosis									1/4			
Oil Red O	11*	233	2333	0		3			222		12	
RATS: WISTARS	X	X	X	X	X	X	X	X	X	X	X	X
SPRAGUE-DAWLEYS												
Liver Pallor												
Inc. lobulation			5/43			X			X		X	
Vacuoles	9/18	15/18	5/43			37/50			50/50			
Focal necrosis	1/18	4/15	13/15	5/13	1/11	37/50					5/50	
Oil Red O	0000*	11222	4/15	1/13		10/10			12/12		12/12	
	0002		22223	0000	00	3/10			2/12		5/12	
Kidney Fatty vacuoles	4/18	3/18	3/15			44			23		233	
MICE: Liver Pallor												
Inc. lobulation	2/40	14/40	31/40			13/13			36/39		40/40	
Vacuoles	1/6	11/40	9/40						38/39		40/40	
Focal necrosis		5/5	6/6		1/5	7/8			6/8		10/10	
Massive necrosis		4/5				2/8			2/8		3/10	
Oil Red O	123*	22	23	0	00	6/8			123		133	
						112234						

Each digit represents one determination of stainable liver fat by Oil Red O staining, graded on a 0-4 scale.

Rats: Livers of rats exposed to the higher concentrations of CCl_4 were pale, with an accentuated lobular pattern (table III). Varying degrees of distinct hepatocellular cytoplasmic vacuolization were seen microscopically in almost every animal exposed to more than $13 \text{ mg/m}^3 \text{ CCl}_4$. A few control Wistar rats had similar liver cell vacuoles which were all devoid of stainable fat. At the higher concentrations of CCl_4 , more severe centrilobular fatty alteration was occasionally observed but no consistent dose-response relationship could be identified. Focal hepatic necrosis occurred frequently at all but the lowest concentrations of CCl_4 , but was not usually accompanied by inflammation which appeared to be an independent, probably infectious process. Oil Red O stains revealed stainable fat at all concentrations of CCl_4 . This was most marked (4/4+) at $594 \text{ mg/m}^3 \text{ CCl}_4$ at altitude. Degenerative fatty vacuoles and pyknosis in renal tubular cells were observed only among exposed Wistars dying in the groups exposed initially.

Wistar rats dying during the initial series of exposures and their altitude controls had the same heavy wet red lungs observed repeatedly in fatalities in this strain at altitude. Several had bloody middle ears. Many instances of pulmonary congestion, hemorrhage, edema, exudation, lymphocytic nodules, eosinophilic perivascularitis, chronic pneumonitis, pulmonary artery edema, alveolar septal widening with influx of mononuclear cells and focal hepatic inflammation were observed among survivors of this strain. These changes were not related to exposure and did not appear so often among Sprague-Dawley rats used later. Other lesions appearing primarily among Sprague-Dawley rats, but also not related to exposure, included atelectasis, advanced murine pneumonia, bronchitis, tracheitis, and pulmonary abscess.

Mice: Pallor and increased lobular pattern of the liver appeared in most exposed mice (table III), being more common in those exposed to the highest concentrations. Three cases of pallor of the kidneys occurred at the highest concentrations, but these were not correlated with any histological lesion. Vacuolization of liver cell cytoplasm was uniformly present in all exposed mice except in the lowest concentration group at altitude in which only 1/6 mice examined had this lesion. Oil Red O stains revealed stainable fat in livers in all exposed groups. The most marked change (4/4+) was found in the $594 \text{ mg/m}^3 \text{ CCl}_4$ group at altitude. Massive necrosis of liver appeared in all six mice examined histologically from the group dying after exposure in this group, and both survivors showed focal necrosis. Five instances of focal hepatic cell necrosis were observed among exposed mice at ambient conditions.

Mice dying during exposure or because of lack of water during the final air control period uniformly had marked confluent pulmonary hemorrhage, congestion and edema. Other lesions observed which were unrelated to the exposures included focal pulmonary congestion, hemorrhage, edema and inflammatory exudate, atelectasis, alveolar septal widening with influx of mononuclear cells, pulmonary arterial edema, bloody or infected middle ears, and pulmonary inflammatory disease represented by peribronchial lymphocytic nodules, bronchitis, and pneumonia. Sporadic cases of focal chronic hepatic inflammation appeared, mostly among exposed animals. Three cases of chronic nephritis occurred in a control group.

DISCUSSION

All species had high levels of sporadic, enzootic, and unrelated pathology, which must not be confused with lesions resulting from the exposure itself.

Although alveolar septal thickening with appearance of large numbers of mononuclear cells, metaplasia of bronchiolar epithelium, and bronchiolar smooth muscle hypertrophy appeared to be related to exposure of dogs to CCl_4 , they have actually been observed before in this laboratory, not only in dogs exposed to 100% oxygen alone at 5 psia, but also among controls.

Pulmonary congestion, edema, and exudation in monkeys were also observed only after exposure to CCl_4 , but because of the sporadic nature of their appearance and the complete absence of any dose relationship, these lesions cannot be attributed to the experimental conditions.

Pulmonary infectious disease in rats, so well described by Innes (ref 4), has been a persistent problem in this work, and despite the use of so-called "Specific Pathogen Free" (Sprague-Dawley) rats in the latter portion of this study, the incidence remained high. This reduces the chance of critically evaluating pulmonary toxicity of this agent in this species.

The Wistar strain is suspect because of its high incidence of mortality at altitude. The 12-20% mortality in this strain is quite comparable to the 15-22% occurring during a 90-day exposure of this strain to the altitude condition alone. Several pathological findings including wet red edematous lungs, absence of pleural effusions, and hemorrhages into the middle ears indicate that vasomotor effects of altitude are possibly important and diminish the likelihood of this mortality being entirely oxygen-induced.

Deaths among ambient control mice were undoubtedly related to water deprivation. The single death in the altitude control group was followed by cannibalization and no pathological examination was possible.

This careful limitation of the proper grounds on which to evaluate comparable effects of CCl_4 at altitude and ambient conditions leaves two areas: changes in the liver in each species and deaths among exposed mice.

In all species the gross appearance of the liver was similar after exposure at comparable concentrations of CCl_4 . No pallor or "nutmeg" pattern was seen in dogs except at the highest concentrations, whereas in monkeys and mice at least occasional pallor was seen at all concentrations.

Mild vacuole formation appeared in dogs at lower concentrations of CCl_4 only at altitude, but at the highest concentrations fatty change was equally severe at altitude and at ambient in air. In monkeys fatty change was severe at all except the lowest concentration. In rats and mice fatty change never became as severe as in both of the above species, and no significant differences between altitude and ambient groups at any concentration were observed.

Focal necrosis was seen sporadically in livers of dogs at the three highest concentrations, and appeared once in a monkey liver at 576 mg/m^3 CCl_4 at ambient.

This lesion occurred frequently in rats at all but the lowest concentrations, but no difference between altitude and ambient groups was demonstrable. All mice examined after death at 594 mg/m³ CCl₄ at altitude had massive necrosis of most of the lobule, most severe centrally. Focal necrosis was also present in both survivors examined, and in some animals at the higher doses both at altitude and ambient, without significant differences between the two environmental conditions.

Oil Red O demonstrated a clear-cut increase in stainable liver fat in dogs at 94 mg/m³ CCl₄ at altitude over that in dogs at 576 mg/m³ CCl₄ at ambient. No other dogs had significant amounts of stainable fat in their livers. In monkeys this stain revealed a greater amount of fat in altitude groups at each comparable concentration. Similarly in rats and mice an extremely large amount of fat was stained at 94 mg/m³ CCl₄, while lesser amounts were found at other concentrations. The difference between comparable groups at lower concentrations was not significant.

Fatty vacuoles in kidney tubules were noted in four dogs and several Wistar rats, all exposed to CCl₄ at altitude. This lesion has not been noted before in these species.

Perhaps the most telling argument for an increased toxic effect of CCl₄ under altitude conditions is the great difference in mortality among mice exposed at the highest concentrations. A total of 38 of 40 mice died at 594 mg/m³ at altitude. All six dead mice examined after the altitude exposure had massive necrosis of liver, and the absence of this lesion in mice dying at ambient would indicate that it was not solely a result of death, but also had some relationship to the exposure to high concentrations of CCl₄ at altitude.

The classic histologic signs of CCl₄ poisoning of the liver are fatty metamorphosis, cytoplasmic acidophilia, cloudy swelling and hydropic degeneration, and cellular necrosis and inflammation (ref 5). All of these were observed in this study. Can one account for the increased incidence of massive necrosis of liver and mortality among mice, and increased stainable fat in all species at comparable concentrations of CCl₄ at altitude?

Recent work has elucidated the basic mechanisms in CCl₄ toxicity. These include loss of intracellular potassium and influx of calcium (ref 6); damage to the endoplasmic reticulum (ref 6, 7, 8, 9, 10); impairment of mitochondrial membrane integrity with entrance of calcium ion (ref 7, 8, 10, 11); swelling of mitochondria with uncoupling of oxidative phosphorylation (ref 6, 7, 10, 11); depressed levels of ATP (ref 12), cytochrome C reductase (ref 11), and reduced forms of pyridine nucleotides (ref 6, 11); increased cytoplasmic levels of acid phosphatase and other enzymes associated with increased activity of unstable lysosomes (ref 9, 13); and peroxidation of unsaturated fatty acids (ref 5).

Cytoplasmic acidophilia has been attributed to release of lysosomal acid phosphatase (ref 9), and the fatty accumulations to decreased ability of the liver to mobilize triglycerides to extrahepatic storage sites and to synthesize stable lipoproteins (ref 5, 7). Cloudy swelling and hydropic change are thought to reflect the damaged and deranged functional state of mitochondria and rough endoplasmic reticulum leading to later autophagocytosis and cellular necrosis (ref 5).

The provocative aspect of these findings is not so much their correlation with the observed histological events as their similarity to the mechanisms thought to be important in oxygen toxicity. Lipid peroxidation, mitochondrial swelling and reduplication, uncoupling of oxidative phosphorylation and depressed levels of reduced pyridine nucleotides have all been observed with oxygen.

Further correlations have been made. Reduced oxygen consumption and metabolic activity as produced by postcordotomy or artificial hypothermia (ref 11, 14) and antioxidants such as vitamin E (alpha-tocopherol) and N, N'-diphenyl-p-phenylenediamine (DPPD) have either ameliorated or slowed the rate of development of some of the manifestations of CCl₄ toxicity, such as necrosis, stainable fat and elevated hepatic triglyceride levels (ref 5). These measures probably act by reducing the formation of lipid peroxides and maintaining the integrity of mitochondrial membranes. DPNH and cytochrome C reductase levels have been stabilized by alpha-tocopherol (ref 5). Administration of ATP (ref 12), and of Phenergan (promethazine hydrochloride) to stabilize mitochondrial membranes (ref 6, 15) have also been protective. EDTA acts similarly, probably by binding calcium ions (ref 11). The actions of some of these agents resemble those produced under the stress of high partial pressures of oxygen alone. Tocopherol especially has been salutary in its effect on hemolysis of red cells exposed to high concentrations of oxygen (ref 16) and on central nervous system manifestations of oxygen toxicity (ref 17).

It is very likely that the basic biochemical mechanisms of both oxygen and CCl₄ toxicity are highly similar. The superimposition of the one stress on the other therefore would be expected to have an additive or synergistic effect, and this is what was found in this study.

REFERENCES

1. Thomas, A. A., Low Ambient Pressure Environments and Toxicity. Arch. Environ. Health, 1965, 11:316-322.
2. Harper, D. T., and Robinson, F. R., Pathology of Animals Exposed for Prolonged Periods to a Pure Oxygen Atmosphere at Reduced Pressures. In preparation.
3. McVean, D. E., et al, An Aqueous Oil Red O Fixative Stain for Histological Preparations. Amer. J. Clin. Path., 1965, 43:291-293.
4. Innes, J. R. M., et al, Pulmonary Disease in Rats. Amer. J. Pathol., 1956, 32:141-159.
5. DiLuzio, N. R., and Costales, F., Inhibition of Ethanol and Carbon Tetrachloride-Induced Fatty Liver by Antioxidants. Exp. Molec. Pathol., 1965, 4:141-154.
6. Dinman, B. D., et al, Carbon Tetrachloride Toxicity III: Hepatostructural and Enzymatic Change. Arch. Environ. Health, 1963, 7:630-646.
7. Heimberg, M., et al, Carbon Tetrachloride Hepatotoxicity: The Direct Action of CCl₄ on the Liver. J. Pharmacol. Exp. Ther., 1964, 145:92-101.
3. Dinman, B. D., Enzymatic Insights to Cell Toxicity. Arch. Environ. Health, 1965, 11:265-271.
2. Stenger, R. J., Hepatic Parenchymal Cell Alterations After Long-Term Carbon Tetrachloride Administration. Amer. J. Pathol., 1963, 43:867-895.
1. Reynolds, E. S., Liver Parenchymal Cell Injury. Lab. Invest., 1964, 13:1457-1470.
1. Plaa, G. L., and Larson, R. E., Carbon Tetrachloride-Induced Liver Damage. Arch. Environ. Health, 1964, 9:536-543.
2. Hyams, D. E., and Isselbacher, K. J., Prevention of Fatty Liver by Administration of Adenosine Triphosphate. Nature, 1964, 204:1196-1197.
3. Schatzki, P. F., Rat Liver Adenosinetriphosphatase. Arch. Path., 1963, 75:85-90.
4. Larson, R. E., and Plaa, G. L., A Correlation of the Effects of Cervical Cordotomy, Hypothermia and Catecholamines on Carbon-Tetrachloride-Induced Hepatic Necrosis. J. Pharmacol. Exp. Ther., 1965, 147:103-111.
5. Rees, K. R., and Smith, J. F., The Presence of Mitochondrial Enzymes in Fat in the Liver in Carbon Tetrachloride Poisoning. J. Path. Bact., 1963, 86:327-331.

REFERENCES (cont'd)

16. Mengel, C. E., et al, Mechanisms of In Vivo Hemolysis Induced by Hyperoxia. Aerosp. Med., 1964, 35:857-860.
17. Zirkle, L. G., et al, Studies of Oxygen Toxicity in the Central Nervous System, Aerosp. Med., 1965, 36:1028-1032.

DISCUSSION

DR. DANON (Weizmann Institute): I would like to draw attention to one misleading impression. In many of the experiments we have heard in the last two days, we put our finger on one finding and then think that the animal died from it. I am referring to the discussion of the previous paper. This carbon tetrachloride intoxication is no exception. At a certain point you can increase the intoxication to such an extent that death will come very soon, and you would think, well, what happened to the cell is what killed the animal. But it is not the mitochondrial function, it is not the use of oxygen, and it is not even the protein synthesis. The proof is that if you take the liver out completely the animal will not die as quickly as it does with carbon tetrachloride. So you should look also into the central nervous system.

CAPT. HARPER: I couldn't agree more. We have seen some pulmonary changes that are statistically suggestive of being introduced by carbon tetrachloride, but we have not been able to show that this is really the mechanism. I have no doubt the central nervous system could also be affected by this agent. All we were able to show in this series of experiments was that the liver changes were enhanced at a comparable concentration of carbon tetrachloride under altitude conditions.

MR. WAGNER (Division of Occupational Health Service): I believe in your report yesterday the inference was that the possible increase in mortality in theistar strain perhaps could have been due to the breaks in the altitude condition. Did this occur in this particular experiment?

CAPT. HARPER: The 80 mg/M³ CCl₄ and the controls each recompressed. I didn't mention this yesterday but in the 14-day group that I spoke about yesterday there was a sharp temporary rise in the rate of death in that dome immediately after one of the recompressions with oxygen. Subsequent recompressions were without from outside leaks, and were not associated with mortality.

DR. MAC FARLAND (Hazleton Laboratories): On that slide you just put on that described some of the conditions of exposure you show some actual concentrations which were above the nominal concentrations. Would you explain how this is possible?

CAPT. HARPER: I'd like to refer that to Dr. MacEwen.

DR. MAC EWEN (Aerojet-General Corporation): As in any experiment you get some fluctuation in the level of contaminant introduction. You have temporary, very short duration high rises or falls. Perhaps something in the generating system would cause it to give a short burst, an accumulation of material in the line suddenly comes through and there was probably a transient low before this. We get the same thing with nitrogen dioxide which we are generating from a compressed liquid which is very temperature sensitive. We occasionally get a little liquification in our delivery system that gives us a short decrease followed by a short high rise. But these are not usually very large.

DR. MAC FARLAND: The reason I asked this question is that in normal experience, of course, actual concentration fluctuates, but it fluctuates well below

the nominal concentration. If I remember the operating characteristics of your chamber, it has a total volume of something on the order of 850 cubic feet or thereabouts.

DR. MAC EWEN: These are not truly what you might call "nominal" concentrations as he indicated. When they said nominal they really meant the concentration we intended to get. We adjusted to that point on the basis of our grab samples. We held it as close to this target as we could and we had probably a plus or minus 15 or 20% variation occasionally.

DR. RIESEN (IIT Research Institute): Just a general comment. I think there's a dimension here we should not overlook. How much of these substances are actually reaching the target organ? Let's consider now anything down to a molecular level, not below that. Oxygen carried by hemoglobin is apparently diffusible through the mitochondrial membrane, is free to enter the mitochondria and produce derangement in the electron transport mechanism. Now let us consider other substances such as carbon tetrachloride. The question I have is whether carbon tetrachloride reaches the site of the mitochondrion at all. We are certain that it gets into the structure and I just wonder where it goes. It's interesting that gamma radiation has been shown in vitro to do many of the same things to enzymes that oxygen does, and it has been shown that some of the protective substances that act against oxygen might act against gamma radiation. It's interesting though that in some other studies of ours we have found that enzyme patterns of LDH are completely and very dramatically deranged in gamma radiation, while with oxygen toxicity this is a nebulous affair. So what is the target, what is predominating, at what level, and how much of this is getting to where this thing is acting? I think these are things that I would like to throw open, particularly for the discussion that follows later.

DR. FAIRCHILD: I think Dr. Riesen's point is real good and hope we can get into this in the forum. Another point brought out by two people, including the speaker, is that we know with hyperbaric oxygen there have been many implications of central nervous system overstimulation. In the mechanisms of oxygen toxicity in general you should think of the sympathetic nervous system.

DR. THOMAS (Toxic Hazards Division): Thank you very much, Dr. Gross and Dr. Fairchild. Let me just once more point out to you that the primary purpose of these studies was not to cast further light on the mechanism of action of carbon tetrachloride. This has been done many, many times at the Gordon Research Conference and I don't think we can compete with that group. All we wanted to do is see if there is an influence on the toxicity of these agents by oxygen atmospheres.

DR. ROTH (Lovelace Foundation): Because of the toxic or more likely chronic adaptive changes produced by 100% oxygen, the medical community has been insistent that the aerospace community get away from 5 psi 100% oxygen and get to a mixed gas environment with more normal partial pressures of oxygen. A 5 psi system was chosen and not a 3-1/2 psi system, primarily to avoid the decompression problem that arises in taking a man from sea level with a minimum period of pre-oxygenation to a 3-1/2 psi environment. If one substitutes an inert gas-oxygen mixture one runs into other problems. Decompression problem is a serious one. There are minor problems with the environmental control system. On the whole, there is no overwhelming mandate for any one of the inert gases from a physiological

or from an engineering point of view. There are minor advantages when you look at decompression sickness with a gas like neon. This is only from a theoretical point of view. There doesn't seem to be any major difference in bend tendency between the helium and the nitrogen environment. When you look at more serious decompression problems, neurocirculatory collapse, chokes, helium does appear to be an advantage. Once again, one can't prove this experimentally because of the rarity of serious symptoms. Therefore, I think it behooves the aerospace community to get as much information as possible on the chronic effects of helium-oxygen, neon-oxygen and nitrogen-oxygen atmospheres.

SESSION IV

SINGLE VS. MIXED GAS ATMOSPHERES

Chairman

Dr. Emanuel M. Roth
Department of Aerospace Medicine
Lovelace Foundation for Medical
Education & Research
Albuquerque, New Mexico

RESUME OF MANNED EXPERIMENTS

Lester J. Krasnogor, Captain, USAF, MC
B. E. Welch, Ph.D.

USAF School of Aerospace Medicine
Brooks Air Force Base, Texas

Several gaseous environments have been considered for manned space flight, ranging from air at sea level pressure to 100% oxygen at an ambient cabin pressure of 181 mm Hg (3.5 psia). An atmosphere of 100% oxygen at low ambient pressure appears attractive from an engineering and monitoring standpoint. Due to concern about chronic exposure to pure oxygen atmospheres (ref 10), there has been great interest in the addition of an inert gas to the space cabin atmosphere with nitrogen and helium receiving the most attention. The purpose of this paper is to present portions of some of the studies (table I) conducted by the Environmental Systems Branch of the USAF School of Aerospace Medicine regarding the biomedical effects of potential space cabin environments. Table I includes only those studies pertinent to the issue of single versus mixed gas atmospheres for manned space flight.

TABLE I

POTENTIAL SPACECRAFT ATMOSPHERES STUDIED AT THE
USAF SCHOOL OF AEROSPACE MEDICINE
ENVIRONMENTAL SYSTEMS BRANCH

<u>Number of Subjects</u>	<u>Duration (Days)</u>	<u>Year Completed</u>	<u>Total Pressure</u>		<u>P_AO₂</u>	<u>Atmosphere Composition</u>	<u>Reference</u>
			<u>mm Hg</u>	<u>psia</u>	<u>mm Hg</u>		
8	17	1961	192	3.7	105	100% Oxygen	5, 7
4	30	1963	258	5.0	171	100% Oxygen	3
4	14	1962	258	5.0	170	100% Oxygen	6
4	56	1965	258	5.0	103	70% Oxygen - 30% Helium	14
4	15	1965	380	7.3	104	44% Oxygen - 56% Helium	13
2	30	1960	380	7.3	90*	40% Oxygen - 60% Nitrogen	7
4	30	1963	700	13.5	171	33% Oxygen - 67% Nitrogen	3

*Approximate calculated value, direct measurement was not done.

The experiments were performed in the USAF School of Aerospace Medicine 2- and 4-Man Space Cabin Simulators over a period of 5 years. Experimental conditions were closely monitored with continuous observation and atmosphere control, scheduled activity, and accurate recording of food and water intake and

excretory output. The subjects underwent extensive physical examination and laboratory evaluation in the pre- and postexperimental periods. Tests of blood, urine, and feces, as well as physiologic measurements (e.g., vital signs, pulmonary function), were carried out during the experimental periods. A medical review of systems was taken by a physician twice daily in addition to continual medical supervision.

In 1961, Morgan et al (ref 5) studied eight subjects exposed to a 100% oxygen atmosphere with a total barometric pressure of 192 mm Hg (3.7 psia) for a period of 17 days. All eight subjects tolerated the atmosphere with only minor complaints. Mucous membrane dryness manifested by eye irritation, pharyngeal inflammation, and nasal dryness were almost universal symptoms. These symptoms were initially suspected of being caused by oxygen toxicity, but subsequently have been shown to be caused by low chamber humidity (ref 3). Aural atelectasis or ear discomfort was a prominent complaint, all subjects noting that they were forced to clear their ears frequently, especially after arising from sleep. Five of the eight subjects had ear discomfort and difficulty clearing their ears at some time during the experimental period.

Crepitant inspiratory rales were heard at the posterior lung bases in six of the eight subjects immediately following the experimental period upon return to ground-level pressure and atmospheric composition. The rales cleared with several deep inspirations. Subsequent chest x-rays were normal. Also, postexperimentally and in contrast to preexperimental results, two subjects showed arterial unsaturation while breathing 100% oxygen at ground level. This finding remains unexplained and was not observed in subsequent 100% oxygen studies (ref 3, 6) in which arterial blood samples were obtained at altitude and in the experimental environment. Pulmonary function tests demonstrated a small decrease (average 7.6%) in forced vital capacity after ascent to altitude with prompt return to baseline values upon descent to ground-level pressures. The fall in forced vital capacity is associated with reduced barometric pressures, but the exact mechanism for the change remains unexplained in the literature. Maximum breathing capacity (MBC) was increased due to the decreased density of the atmosphere which lowers the resistance to flow in the airways.

Cardiovascular deconditioning was observed, manifested by a decrease in treadmill time (Balke Test), decreased orthostatic tolerance on the tilt table, and increase in the pulse rate during the Master's Exercise Tolerance Test, as compared with preexperimental baseline values. This has been observed in all of the other studies with the exception of that reported by Zeff et al (ref 14) and is believed due to inactivity which accompanies confinement in the space cabin simulator (ref 4). In that particular study, a rigorous exercise program counteracted the effects of confinement, and cardiovascular deconditioning was prevented.

In a second 100% oxygen study (ref 6), four subjects were exposed for 14 days at a total barometric pressure of 258 mm Hg (5 psia). No arterial desaturation was observed in any of the subjects on days 1, 7, and 14 of the exposure. A fall in hematocrit was observed during the initial part of the experiment, averaging 6.7% lower than preexperimental values. The fourth subject showed a more pronounced decrease and was thought to have a "self-limiting non-specific anemia. . .". The authors did not attribute the change in hematocrit directly to the hyperoxia and felt that the loss of blood due to repetitive sampling was a confusing factor. Atelectasis

was not noted, either on x-ray films obtained at altitude or by comparison of duplicate vital capacity values.

Similar results were obtained in a longer duration, more comprehensive study of four subjects exposed to a 258 mm Hg (5 psia) atmosphere for 30 days (ref 3). Few symptoms were noted, and mucous membrane dryness and aural atelectasis continued to be major complaints. Rales were heard on auscultation of the lungs in two subjects on one occasion, but no postexperimental x-ray abnormality was found. A decrease in vital capacity and an increase in MBC, related to decreased barometric pressure, were again observed (ref 8). Arterial unsaturation was not noted, nor was there any change in carbon monoxide diffusing capacity.

A major finding in this study (ref 12) was an average drop in the hematocrit of 9.1% as opposed to 3.4% in the control subjects. Most of the decrease in hematocrit took place during the first 2 weeks of exposure and the hematocrit stabilized during the last 2 weeks. Similar changes were noted in hemoglobin levels and red cell counts. Extensive hematologic studies were essentially normal, and no evidence for hemolysis was found. The hematology evaluations included plasma ^{59}Fe clearance rates, red cell utilization of ^{59}Fe , bone marrows, osmotic fragility curves, ^{51}Cr half-life, red cell glutathione stability and glucose-6-phosphate dehydrogenase levels, and urine and fecal urobilinogen. The fall in hematocrit is most likely related to hyperoxia ($P_{\text{A}\text{O}_2} = 171$ mm Hg), but the exact mechanism remains unexplained and is presently under extensive investigation. The change in hematocrit was not of enough magnitude to constitute a clinical problem, at least for 30 days.

A companion study (ref 3) to the 100% oxygen experiment just discussed was performed in order to investigate the effects of the presence of an inert gas. The alveolar oxygen tension was kept the same in both studies ($P_{\text{A}\text{O}_2} = 171$ mm Hg), but in this case, an inert gas (nitrogen) was added, bringing the total barometric pressure to 700 mm Hg (13.5 psia). No symptoms were reported by the subjects. Aural atelectasis, a prominent finding in the two 100% oxygen studies, was not observed since the presence of an inert gas limits the development of a significant negative pressure in the middle ear which occurs as oxygen is absorbed by the mucosal lining.

No changes in pulmonary function were observed (ref 8), as expected, because of the small reduction in total barometric pressure. A fall in hematocrit was observed (average 6.7%) (ref 12), but was not as large as in the companion 100% oxygen study (average 9.1%). The remainder of the hematological studies were normal.

In another oxygen-nitrogen study (ref 7), two subjects were exposed to 40% oxygen with a total barometric pressure of 380 mm Hg (7.35 psia) for 30 days. This atmosphere provided an alveolar oxygen tension of approximately 90 mm Hg. The subjects tolerated the conditions very well, and no symptoms were reported.

Two large-scale studies (ref 13, 14) have been carried out by the Environmental Systems Branch using a helium-oxygen environment. In the first experiment (ref 13), four subjects lived in a 44% oxygen-56% helium atmosphere at a total pressure of 380 mm Hg (7.35 psia) for 15 days. This atmosphere resulted in

an average alveolar oxygen tension of 104 mm Hg. Except for eye irritation when the cabin humidity was low, no symptoms were reported. Minimal proteinuria was observed intermittently on morning urine specimens in three subjects (including one subject who had to be removed from the cabin because of acute prostatitis). The proteinuria was thought probably to be related to the concentration of the early morning specimens as other renal studies were normal, and no proteinuria was found on 24-hour urine specimens in the second longer duration oxygen-helium flight (ref 2). The prostatitis was unrelated to the experimental exposure.

In an attempt to prevent the cardiovascular deconditioning associated with confinement and inactivity and to study thermal balance, the subjects exercised on a bicycle ergometer for 1 hour every 4th day. This exercise regimen resulted in somewhat less of a deconditioning effect than was seen on earlier studies (ref 3, 7). The treadmill time (Balke Test) decreased 18% on the average as opposed to earlier reports of 29% (ref 7) and 35% (ref 3). The thermal balance study (ref 1) revealed heat exchange to be essentially unchanged from that in air at ground level.

In a second helium-oxygen study (ref 14), four subjects were exposed for 56 days to a 70% oxygen-30% helium atmosphere at a total pressure of 258 mm Hg (5 psia). Alveolar oxygen tensions were found to average 103 mm Hg. This atmosphere was well tolerated by all four subjects, and only two significant symptoms were reported: dry mucous membranes and increased intestinal gas and flatus. The dry membranes were relieved with an increase in cabin humidity. Fruit juices in the diet were most likely responsible for the excess intestinal gas and flatus. This problem may have been aggravated by helium which would tend to be less readily absorbed from the GI tract than oxygen.

One subject showed a small rise in serum glutamic oxaloacetic transaminase (SGOT) and serum glutamic pyruvic transaminase (SGPT) (figure 1), which returned to normal values before the end of the exposure. All other liver function tests were normal, including serum protein electrophoresis and bromsulphthalein (BSP) excretion. This enzyme change was thought to be unrelated to the atmosphere exposure and perhaps represented a mild anicteric viral hepatitis. Another subject showed mucous membrane thickening of the left frontal and maxillary sinuses. This rapidly cleared with erythromycin therapy.

Cardiovascular deconditioning was not observed in this study (ref 15). Each subject exercised on a bicycle ergometer for 20 minutes three times a day for 6 days each week. This exercise regimen proved vigorous enough to counteract the effects of confinement and inactivity associated with all previous space cabin simulator studies. No changes in hematocrit were observed in either the first or second helium-oxygen studies (ref 13, 14), and all other hematologic measurements remained normal.

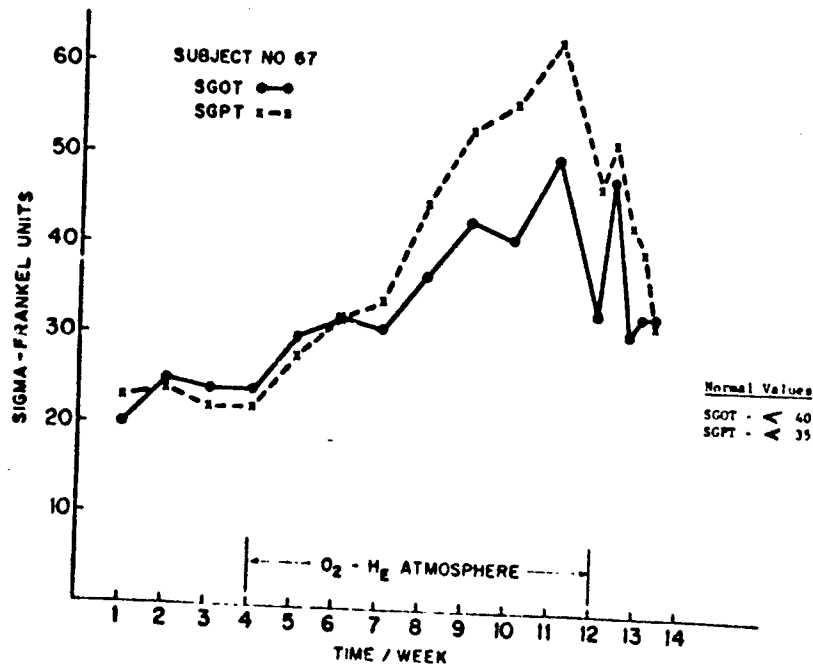

Figure 1. SERUM GLUTAMIC-OXALOACETIC AND GLUTAMIC-PYRUVIC TRANSAMINASES (From Zeft, et al)

DISCUSSION

Mucous membrane drying with its consequent symptoms was observed in all of these studies and could be prevented by keeping the cabin relative humidity above 30-40%. Aural atelectasis was a consistent finding in the 100% oxygen studies and was prevented when an inert gas was present in the atmosphere. Conceivably, an incapacitating middle ear block could occur in a 100% oxygen atmosphere, but a severe block with a serous or hemorrhagic exudate has not yet occurred in actual or simulated space flight in a single gas atmosphere (i. e., 100% oxygen).

Although rales were occasionally heard in the single gas environment, no conclusive evidence for atelectasis was found in these studies. The presence of an inert gas would seem to offer an extra margin of safety against possible atelectasis under conditions of increased G forces such as encountered during exit and reentry phases of space flight (ref 11).

The fall in hematocrit observed in the 258 mm Hg 100% oxygen studies is presently under investigation. The hyperoxia ($P_{A_{O_2}} = 171$ mm Hg) in these studies and in the companion oxygen-nitrogen study is most likely responsible for the observed change in hematocrit. In the two helium studies, the average alveolar oxygen tension approximated ground level conditions in air (ref 8, 9), and no decrease in hematocrit was observed. In addition, both of these studies, unlike the others discussed, included exercise programs which would tend to counteract any decrease in hematocrit seen with deconditioning (ref 4).

SUMMARY

All atmospheres tested were tolerated well enough so that the studies were all completed without major difficulties. Those studies involving oxygen at higher

than normal alveolar tensions resulted in decreases in hematocrit which were not of enough magnitude to be a clinical problem over the span of the experiments but could conceivably become serious in a more prolonged exposure. The presence of an inert gas has certain real and theoretical advantages over the single gas atmosphere. There were no detectable differences between nitrogen and helium that would favor either gas from a biomedical viewpoint.

As a final comment, it should be pointed out that in light of all the changes presented in animal studies in earlier talks at this Conference, there is a greater need for reevaluation and further research regarding the correlation of findings in animals with those in humans.

REFERENCES

1. Epperson, W. L., Quigley, D. G., Robertson, W. G., Behar, V. S., and Welch, B. E.: Observations on Man in an Oxygen-Helium Environment at 380 mm Hg Total Pressure: III. Heat Exchange. Aerospace Med., 37:457, 1966.
2. Glatte, H. V., and Giannetta, C. L.: The Study of Man During a 56-Day Exposure to an Oxygen-Helium Atmosphere at 258 mm Hg Total Pressure: III. Renal Response. Aerospace Med., 37:559, 1966.
3. Herlocher, James E., Quigley, David G., Behar, Victor S., Shaw, E. G., and Welch, B. E.: Physiologic Response to Increased Oxygen Partial Pressure. I. Clinical Observations. Aerospace Med., 35:613, 1964.
4. Lamb, L. E., Johnson, R. L., Stevens, P. M., and Welch, B. E.: Cardiovascular Deconditioning from Space Cabin Simulator Confinement. Aerospace Med., 35:420, 1964.
5. Morgan, Thomas E., Jr., Ulvedal, Frode, Cutler, Ralph G., and Welch, B. E.: Effects on Man of Prolonged Exposure to Oxygen at a Total Pressure of 190 mm Hg. Aerospace Med., 34:589, 1963.
6. Morgan, Thomas E., Jr., Cutler, Ralph G., Shaw, Emil G., Ulvedal, Frode, Hargreaves, John J., Moyer, James E., McKenzie, Richard E., and Welch, B. E.: Physiologic Effects of Exposure to Increased Oxygen Tension at 5 psia. Aerospace Med., 34:720, 1963.
7. Morgan, Thomas E., Jr., Ulvedal, Frode, and Welch, B. E.: Observations in the SAM Two-Man Space Cabin Simulator. II. Biomedical Aspects. Aerospace Med., 32:591, 1961.
8. Robertson, William G., Hargreaves, John J., Herlocher, James E., and Welch, B. E.: Physiologic Response to Increased Oxygen Partial Pressure. II. Respiratory Studies. Aerospace Med., 35:618, 1964.
9. Robertson, W. G., and McRae, G. L.: The Study of Man During a 56-Day Exposure to an Oxygen-Helium Atmosphere at 258 mm Hg Total Pressure: VII. Respiratory Function. Aerospace Med., 37:578, 1966.

REFERENCES (CONT'D)

10. Welch, B. E., Morgan, T. E., Jr., and Clamann, H. G.: Time-Concentration Effects in Relation to Oxygen Toxicity in Man. Fed. Proc., 22:1053, 1963.
11. Welch, B. E., and Robertson, William G.: Effect of Inert Gases in Cabin Atmospheres. Third International Symposium on Bioastronautics and the Exploration of Space, Aerospace Medical Division, USAF, Brooks AFB, Texas, December 1965.
12. Zalusky, Ralph, Ulvedal, Frode, Herlocher, James E., and Welch, B. E.: Physiologic Response to Increased Oxygen Partial Pressure. III. Hematopoiesis. Aerospace Med., 35:622, 1964.
13. Zeft, Howard J., Behar, Victor S., Quigley, David G., Ulvedal, Frode, Shaw, E. G., and Welch, B. E.: Observations on Man in an Oxygen-Helium Environment at 380 mm Hg Total Pressure: I. Clinical. Aerospace Med., 37:449, 1966.
14. Zeft, Howard J., Krasnogor, Lester J., Motsay, George J., Glatte, Hayden V., Robertson, William G., and Welch, B. E.: The Study of Man During a 56-Day Exposure to an Oxygen-Helium Atmosphere at 258 mm Hg Total Pressure: XII. Clinical Observations. Aerospace Med., 37:601, 1966.
15. Zeft, Howard J., Robertson, William G., and Welch, B. E.: The Study of Man During a 56-Day Exposure to an Oxygen-Helium Atmosphere at 258 mm Hg Total Pressure: V. Exercise Performance and Cardiovascular Response. Aerospace Med., 37:566, 1966.

DISCUSSION

CAPT. KAPLAN (Toxic Hazards Division): I think it's been pretty well accepted that the atelectasis which occurs in the pure oxygen environment is, as you suggested, because of the collapse of distal alveoli that are normally kept expanded by the presence of inert gases between deep respirations that we usually only take about once every 15 minutes or so. A couple of years ago, Akadasian did some experiments with mice with a long exposure for about 60 days I think, or perhaps even longer than that, and found definite evidence of atelectasis occurring initially in pure oxygen. After about the 40th day, this disappeared and the suggestion was that perhaps these animals adapt on a reflex basis, taking their deeper respirations instead of every 15 minutes perhaps once every 5 minutes. There was an attempt made to examine the respiratory patterns in pure oxygen exposures of the human volunteers to see if there was any change in the breathing pattern later in the experimental exposure.

CAPT. KRASNOGOR: I don't believe any specific investigation along these lines was conducted. However, no signs of deeper respirations were noted and in all the pulmonary function studies that were done there were no changes in breathing pattern.

MR. BROOKSBY (NASA Ames Research Center): In those studies where you had a decrease in vital capacity, did that persist throughout the duration of the experiment or was it a transitory thing they experienced when they first went to altitude? What was the situation there?

CAPT. KRASNOGOR: The decreased vital capacity is seen in all studies where the subjects were taken to altitude. It was present throughout the study, it remained constant, it ranged from about 2.5% to 6.5% decrease, and immediately returned to normal values upon descent to ground level conditions.

MR. BUSBY (Ohio State University): I was wondering whether or not you had had any need for shortening your sleep cycle to prevent problems with aural atelectasis, and I was also wondering whether Dr. Welch thought of doing any audiometry on his subjects to see whether or not there were minor changes in hearing.

CAPT. KRASNOGOR: As far as the sleep cycles were concerned, we did not have to shorten them. The subjects slept a normal amount of time except for noise in the chamber, such as during pass-lock operations, when they would be awakened and perhaps unconsciously clear their ears during this period of time. Subjects did have extensive ear, nose, and throat work before and after these studies. There was no testing done during the actual flights themselves.

DR. FISCHER (NASA Manned Spacecraft Center): Whenever you do a study in which you observe a decrease in the hematocrit and you do a Chromium $T_{1/2}$ without referencing it to directly observed red cell masses, you might get a disparity such as was reported. For instance, you assume when you do a Chromium $T_{1/2}$ that's the method employed in this test, that you have a constant red cell mass and a constant rate of production. I think they very nicely showed that the rate of

roduction didn't change. There's a possibility at least that the red cell mass did indeed decrease and this, of course, changes the Chromium $T_{1/2}$ back toward a normal slope and I think unless you have directly measured $T^{51}\text{Cr}$ red cell masses you can't make the statement that the red cell survival based on the Chromium $T_{1/2}$ was normal. I think this is a technical problem.

CAPT. KRASNOGOR: Plasma volumes were done which weren't changed but we did not have the direct red cell mass determination on the 56-day helium oxygen.

MR. MASON (NASA Langley Research Center): Captain, would you comment a little further on the thermal balance studies that you did?

CAPT. KRASNOGOR: These studies involved the methods of loss of heat by convection and conduction. There were skin thermocouples placed on the subjects and I don't know the details of the study since I was not there at the time, but having read the paper and having spoken with the investigator, they found that in that particular atmosphere of helium and oxygen there was no change in loss of heat from the body via convection or conduction. It was no different from ground level ambient air conditions.

DR. ROTH: May I add a bit to that? I have just reviewed the thermal problem in mixed gas systems and had a chance to talk with Dr. Welch about this. The only significant finding I think was that the comfort zone temperature - the average temperature which people set the thermostat on a voluntary basis - was about 75 F compared to about 69 F under ambient conditions. So this is essentially what might be predicted from a purely thermodynamic basis. You have a dilution of the helium effect by virtue of the fact you have only 30% helium and 70% oxygen. You do get an increase in thermal conductivity which allows you to maintain a higher comfort zone temperature. I think that's the only significant finding.

EFFECT OF A MIXED GAS ATMOSPHERE AT 5 PSIA ON THE TOXICITY OF NO₂ AND O₃ IN ANIMALS

James D. MacEwen, Ph.D.
James M. McNerney, M.S.

Aerojet-General Corporation
Wright-Patterson Air Force Base, Ohio

Comparative toxicity studies on NO₂ and O₃, both in 100% oxygen and in air at near atmospheric pressure, were presented at the 1st Annual Conference on 30 March - 1 April 1965. The primary conclusion drawn from these studies was that the 5 psia 100% oxygen environment produced a protective effect against the pulmonary irritant gases. This protective effect was believed to be due to the increased partial pressure of oxygen present in the alveolar environment of the exposed animal.

There is a strong possibility that future space systems may use an atmosphere composed of two gases, oxygen and helium, with a pO₂ of 175 mm Hg. The question arose whether the protective action of 5 psia 100% oxygen against pulmonary irritants would exist with this gas mixture of lower oxygen partial pressure. An experimental protocol, similar to that used previously for 2-week continuous exposures to the intermediate chamber concentrations of NO₂ and O₃ (38.8 and 8.0 mg/M³, respectively), was designed to study the effect of a mixed gas environment on the toxicity of these gases. Nitrogen, rather than helium, was used as the inert part of the gas mixture. The reason for its application is twofold: (1) the chambers were already equipped to prepare air-oxygen mixtures and the desired mixture could be obtained by proper adjustment of the gas blending valves and (2) the use of helium would have required modification of the chamber gas supply system and the costly installation of helium storage facilities.

Baseline values were obtained for animal room controls, dome test controls and animals for actual contaminant exposure; these nonfasting values represent five preexposure tests at 2-week intervals. For a period of 2 weeks, the dome test control group animals were subjected to the same environmental conditions as the "test" group but minus the pulmonary irritant gas. At the end of that period, examination of the control animals exposed to the mixed gas environment at 5 psia showed no significant differences between their clinical laboratory test values and either those baseline values of the animal room controls or their own preexposure values. The blood values for the conditions studied in beagle dogs and monkeys are shown in table I. Although there appears to be a slight upward trend in SGPT and SGOT serum levels, the increase is not significant and is within the normal variation of individual animals. Growth rates and organ-to-body weight ratios were comparable in both the animal room and dome test control animals.

The 14-day continuous exposure of laboratory animals to an ozone chamber concentration of 8.0 mg/M³ in the mixed gas environment at 5 psia resulted in a mortality that was intermediate to the studies reported previously (table II). There was no significant change in rodent mortality, but in dogs and monkeys there was an effect intermediate to those in ambient air and 5 psia 100% oxygen environments which appeared to be in proportion to the oxygen partial pressure.

TABLE I

EFFECT OF 5 PSIA - MIXED GAS ENVIRONMENT,
68% O₂ - 32% N₂, 14-DAY CONTINUOUS EXPOSURE
ON CLINICAL LABORATORY TEST VALUES

BLOOD TEST	UNITS	MONKEYS					
		BEAGLE DOGS			MONKEYS		
		BASE- LINE	14-DAY EXPOSURE	A. R. CONTROLS	BASE- LINE	14-DAY EXPOSURE	A. R. CONTROLS
HCT	(Vol. /%)	44	44	49	40	43	41
HGB	(gm. %)	14.9	14.2	15.6	12.6	12.8	12.0
RBC	(x 10 ⁶)	6.2	6.2	6.8	5.3	5.5	5.3
WBC	(x 10 ³)	14.4	15.5	13.8	10.9	12.8	13.4
SODIUM	(mEq./l.)	143	143	148	145	144	148
POTASSIUM	(mEq./l.)	4.7	5.1	5.6	4.5	4.2	5.1
CALCIUM	(mEq./l.)	5.5	5.4	5.9	5.4	5.2	6.0
T. PROTEIN	(gm. %)	5.5	6.0	6.0	7.6	7.6	7.3
ALBUMIN	(gm. %)	3.3	3.3	3.6	4.6	4.6	3.9
SGPT	(U./ml.)	24	31	21	31	35	20
SGOT	(U./ml.)	29	36	37	42	49	38
ALK. P'TASE	(U./ml.)	2.3	2.5	1.8	25	19	14
T. PHOS.	(mg. %)	5.4	6.1	6.0	5.1	6.1	4.4
LDH	(U./ml.)	234	324	382	429	408	475

In order to verify the protective effect of oxygen against O₃ toxicity, an additional experiment was conducted at near ambient pressure (720 mm Hg) air enriched with oxygen to produce a pO₂ of 260 mm Hg. Only dogs and monkeys were used in this experiment since there had been no clear-cut protection in rodents during prior experiments. The mortality response was reduced to zero (table II) and no clinical symptoms of ozone toxicity could be observed in the exposed animals.

TABLE II

MORTALITY PRODUCED DURING
14-DAY CONTINUOUS EXPOSURE
TO OZONE - 8.0 mg/M³
(NO. DEATHS/NO. EXPOSED)

TOTAL PRESSURE (mm Hg)	700	260	260	720
pO ₂ (mm Hg)	140	175	260	257
GAS SUPPLY	Air	68% O ₂ - 32% N ₂	100% O ₂	36% O ₂ - 64% N ₂
<hr/>				
<u>SPECIES</u>				
MICE	33/40	32/40	33/40	-
RATS	50/50	45/50	45/50	-
GUINEA PIGS	8/8	9/9	8/8	-
DOGS	5/5	6/8	2/8	0/8
MONKEYS	2/4	1/4	0/4	0/4

Clinical blood test data on samples taken from survivors showed no significant differences between the animals exposed to 8.0 mg/M³ O₃ concentrations at the four environmental conditions studied. There were differences, however, in the lung weight to body weight ratios, shown in table III, for the various test environments. The intermediate pO₂ of the mixed gas environment resulted in the highest lung weight to body weight ratio while the test conducted at near ambient pressure with oxygen-enriched air resulted in a near normal pattern.

The effect of mixed gas environments at reduced pressure on NO₂ toxicity were somewhat different from those seen in O₃ toxicity. As shown in table IV, there appears to be an intermediate effect in monkey mortality in comparison with ambient or 5 psia 100% oxygen conditions. When, however, dogs and monkeys were challenged with the same atmospheric concentration of NO₂ in oxygen-enriched air at near ambient pressure, the toxic response was more like that seen earlier in air at near ambient pressure, i. e., no decrease in mortality. Again, rodents were not used since insignificant mortality had been observed in previous exposures at the same chamber concentration of toxicant.

TABLE III

EFFECT OF OZONE ON LUNG WEIGHT TO BODY WEIGHT RATIO
FOR A 14-DAY CONTINUOUS EXPOSURE(CHAMBER CONCENTRATION - 8.0 mg/M³)

TOTAL PRESSURE (mm Hg)	700	260	260	720	
pO ₂ (mm Hg)	140	260	175	260	UNEXPOSED
GAS SUPPLY	Air	100% O ₂	68% O ₂ - 32% N ₂	36% O ₂ - 64% N ₂	CONTROLS
<hr/>					
<u>BEAGLE DOGS</u>					
MALES (4) TEST	.033	.029	.041	.019	.012
FEMALES (4) TEST	.039	.020	.053	.018	.010
<u>MONKEYS</u>					
MALES (2) TEST	.016	--	.021	.011	.009
FEMALES (2) TEST	--	.010	.018	.012	.007
<u>RATS</u>					
MALE (25) TEST	.026	.021	.024	--	.006
FEMALES (25) TEST	.027	.025	.025	--	.008

TABLE IV

MORTALITY PRODUCED DURING
14-DAY CONTINUOUS EXPOSURE
TO NITROGEN DIOXIDE - 38.8 mg/M³
(NO. DEATHS/NO. EXPOSED)

TOTAL PRESSURE (mm Hg)	700	260	260	720
pO ₂ (mm Hg)	140	175	260	260
GAS SUPPLY	Air	68% O ₂ - 32% N ₂	100% O ₂	36% O ₂ - 64% N ₂
<hr/>				
<u>SPECIES</u>				
MICE	2/40	8/40	0/40	
RATS	7/50	1/50	3/50	
DOGS	0/6	0/8	0/8	1/8
MONKEYS	4/4	3/4	2/4	4/4

TABLE V

MORTALITY PRODUCED DURING CONTINUOUS EXPOSURE
TO HIGH CONCENTRATIONS OF NITROGEN DIOXIDE -
85 mg/M³

TOTAL PRESSURE (mm Hg)	OCCURRENCE OF DEATHS BY SPECIES														
	MICE (40)			RATS (50)			BEAGLES (8)								
	260	700	720	260	700	720	260	700	720	260	700	720			
pO ₂ (mm Hg)	260	140	260	260	140	260	260	140	260	260	140	260			
GAS SUPPLY	100% O ₂	Air	36% O ₂ - 64% N ₂	100% O ₂	Air	36% O ₂ - 64% N ₂	100% O ₂	Air	36% O ₂ - 64% N ₂	100% O ₂	Air	36% O ₂ - 64% N ₂			
DAY OF EXPOSURE	1	2	3	4	5	6	7	8	9	10	11	12	13	14	
	0	9	8	2	1	6	4	1	2	2	2	3	1	0	1
	0	3	15	2	3	*	0	3	0	8	7	6	1	1	2
	0	21	16	3	0	0	0	41	0	0	0	0	0	0	0
	0	3	2	3	0	0	0	9	25	18	3	0	0	0	0
	0	0	0	0	0	0	0	0	0	0	0	0	0	0	0
	0	0	0	0	0	0	0	0	0	0	0	0	0	0	0
	0	0	0	0	0	0	0	0	0	0	0	0	0	0	0
	0	0	0	0	0	0	0	0	0	0	0	0	0	0	0
	0	0	0	0	0	0	0	0	0	0	0	0	0	0	0
	0	0	0	0	0	0	0	0	0	0	0	0	0	0	0
TOTALS	40	40	23*	37	50	46*	7	8	7*						

*Terminated after 5 days

There was some indication of prolongation of time to death in this latter experiment. Therefore, another experiment was conducted challenging the animals to a higher concentration of NO_2 but with the same environmental conditions. In table V, the results of this experiment are compared with previous studies with the increased contaminant concentration also conducted in this laboratory. The oxygen-enriched atmosphere did delay the time of death and the surviving animals showed clinical signs of improvement. The experiment was terminated after 5 days, however, since the information sought had been obtained.

In conclusion, it may be said again that there is a reduction in toxicity of pulmonary irritants in a 5 psia 100% oxygen environment and that this protection is apparently the result of increased oxygen partial pressure. In ozone, the protective action of oxygen is clear-cut and extends into the ambient pressure range. This may indicate the potential efficacy of oxygen therapy in ozone exposures. The evidence for the protective action of oxygen against NO_2 toxicity is not as definite.

It has been shown by Fairchild (ref 1, 2) and others that the probable mechanism of action of ozone toxicity is action on biologic sulfhydryl-containing compounds of the protein-lipid lung-film layer with free radical formation. It has also been stated by Stokinger (ref 3) that the mechanism of NO_2 toxicity appeared to be the same as that of ozone by analogy of their common effects in experimental animals. It would appear from the results of the experiments described herein that there are at least subtle differences between the biologic mechanisms of action of O_3 and NO_2 that are yet to be resolved.

ACKNOWLEDGMENT

This work was supported by the Aerospace Medical Research Laboratories under Contract AF 33(657)-11305 and by the National Aeronautics and Space Administration under PR T-31248-G.

REFERENCES

1. Fairchild, E. J. II. Neurohumoral Factors in Injury From Inhaled Irritants. *Arch. Envir. Health* 6, 79, 1963.
2. Fairchild, E. J. II and S. L. Graham. Thyroid Influence on the Toxicity of Respiratory Irritant Gases, Ozone and Nitrogen Dioxide. *J. Pharmacol. Exptl. Therap.* 139, 177, 1963.
3. Handbook of Physiology, Vol. II of Section III. W. O. Fenn and H. Rahn (editors), Chapter 42, American Physiology Society, Washington, D.C. 1965.

DISCUSSION

DR. ROTH: I'd like to open the discussion and ask whether there was any difference in the amount of atelectasis shown in the two situations?

DR. THOMAS: The pathology data are not complete yet but we don't see gross atelectasis. We don't have it at the beginning even.

DR. MAC EWEN: These experiments were just completed within the last month or so.

DR. SCHAEFER (U. S. Naval Medical Research Laboratory): Is there an explanation of the protective effect of oxygen?

DR. MAC EWEN: No, I think that we need to look into mechanisms a little further.

DR. SCHAEFER: Any suggestions?

DR. MAC EWEN: No, not really at this point.

OPEN FORUM

DR. ROTH (Lovelace Foundation): The ground rules for the discussion are the following: we have received questions here, most of which seem to be quite pertinent. We'll try to go through the questions in the order that they were received. Quite often they're directed to an individual. That individual can rise and answer the question; otherwise, we'll throw the question open to general discussion and try to cut it off as soon as we can without getting out on the fringes.

The first question was directed to Dr. Fischer, NASA, Manned Spacecraft Center, by several people. Dr. Fischer has been involved with the studies of red cell changes in the astronauts and it was felt that the review of this problem presented by Capt. Kaplan did not go into enough detail on the red cell changes which were of interest to several individuals. I wonder if Dr. Fischer would wish to say a few words about the studies that were actually done on the red cell changes in the astronauts in the Gemini series?

DR. FISCHER: Actually our studies started out very modestly. We initially did only a plasma volume, not expecting to look at the red cells in any detail, and subsequently, more or less just as a matter of interest, we calculated the red cell mass, pre- and postflight, from a peripheral hematocrit and on ^{125}I plasma volume. It was for the first time that we demonstrated at least a suggestion of a decreased red cell mass, and as Capt. Kaplan reported, the loss was in the neighborhood of 13% for the command pilot and the pilot. Of course, we realized that a calculated red cell mass is a very gross thing, it has many inherent inaccuracies, and that it would, therefore, be necessary on the subsequent flights to do a ^{51}Cr tag and directly measure red cell mass and plasma volume. On GT-V this, indeed, was done. We demonstrated after 6 days in space a directly measured loss of 20% of the circulating red cell mass. It must also be said that comparison on subsequent flights showed that the peripheral hematocrit and the total body hematocrit ratio changed between the basal preflight condition and the basal postflight condition. This means that our calculated red cell mass on GT-IV had to be corrected; in other words, instead of a 13% drop upon recalculation based on direct observations later on, it was more in the neighborhood of 8%. After 4 days we had an 8% calculated drop in red cell mass. After 8 days in flight we had a 20% drop in red cell mass and on GT-VII, which was 14 days in space, we again repeated the direct ^{51}Cr red cell mass determination of plasma volume. One pilot, as Capt. Kaplan mentioned, exhibited a reduction of 19% at 14 days while the other pilot had essentially no change. Now, as he also mentioned, the man who showed no loss of red cell mass was not a normal person in this respect. He apparently has familial intermittent hyperbilirubinemia (indirect hyperbilirubinemia) or Gilbert's syndrome. This is only a clinical entity - at the moment. There are many enzyme defects which appear to be associated with this syndrome and it is not very well understood to date. However, we have observed that this individual frequently runs about a 2 milligram percent indirect bilirubin. We have sort of a pathological control here. In other words, the "normal" man shows the typical response noted in the four other pilots. The man with Gilbert's shows no response at all.

We have some special hematologic data that backs up the observation on GT-VII. These are, specifically, extensive red cell indices, osmotic fragility

done by the classical basic technique, and reticulocyte counts, all monitored for extended periods before and after the flight. Just briefly, I can say that the man on GT-VII who showed a decreasing red cell mass also showed a pronounced shift of his red cell osmotic fragility into the more fragile zone. It was quite significant and quite dramatic. It was well controlled. I always run my own blood sample concurrently, so I always know whether observed variations from normal arise from errors in technique or whether they reflect actual changes. The observations I'm reporting here were all valid. We also saw a very dramatic increase of mean corpuscular volume. This astronaut's mean for five separate determinations in a week, I think, prior to mission, showed a volume averaging between 86 and 89 cubic microns. Postflight for the first three days he consistently ran mean cell volumes over 100 cubic microns, as high as 102. This was associated with the concomitant decrease in the mean corpuscular hemoglobin concentration. I think this was signifying that the cell was imbibing a diluent. These things added together correlate very nicely with the shift in basic osmotic fragility. Also, at just about the time expected, about the fourth postflight day, indeed, the red cell mass decreased. You'd expect to see his reticulocytes start up, and they did, and they reached a 3.6% level by the 20th day, after which no further reticulocyte counts were done. I think it makes it a pretty nice, clear-cut picture that one, a drop in red cell mass does occur on space flights; two, there is apparently (at least in one observation where many of the tests were done) an associated increase in the size of the cell, probably due to an imbibation of fluid. The cell becomes more fragile and apparently is lysed.

This is not a red cell production problem. We have only one gross estimate of production and that is the slope of our Chromium $T_{1/2}$ red cell survival curve. It does not follow a pattern that would correlate with failure of red cell production. In other words, it slopes off, meaning the red cell population is indeed being diluted by new cells; otherwise you would get a very flat red cell survival curve. So it's not a problem in production, it is an active hemolysis and the basis for the hemolysis we don't know. I say this is hemolysis because we know there is no sequestration (and when I say "sequestration" I mean an unavailability of some portion of the red cell mass). We can make this statement based on the fact that samples taken at 6, 12, 24, and 48 hours after the mission and for about four days show no reappearance of any portion of the red cell mass which might have been previously unavailable for mixing. Complete mixing is achieved pre- and postflight by the 6th minute and our samples aren't taken until the 15th, so we know complete mixing of the circulation indeed occurred and there's no portion of the red cell mass which was unavailable for mixing with the tagged cell population. Therefore, this is hemolytic anemia.

There are some other things, as I mentioned previously. As far as the Chromium survival is concerned, we adjust our Chromium survival always with the red cell mass done for every point on the red cell survival curve. It's a very important thing because as I said before, when you do a red cell survival, if you don't measure your red cell mass, you have to assume a constant red cell mass and a constant rate of production. We don't assume this, we measure it. I think that more or less covers most of the comments I had. Oh, yes, as far as which portion of the red cell population is being affected, it's our feeling at the moment and this is not yet well demonstrated objectively, that the older cells are being selected out, are undergoing you might say, an early senescence. We base this on the fact that the Chromium $T_{1/2}$ values obtained postflight are markedly elevated.

meaning that a younger population of cells have probably been tagged. We have a very intensive program in the offing for the next few missions and I think we can start now looking into this in earnest. I think the reduction in red cell mass is well demonstrated and now it's up to us to find out exactly what the mechanisms are.

DR. COULSTON (Albany Medical College): I have a couple of comments. Did you ever see any of the so-called "Innen Körper" in the red cells of these people?

DR. FISCHER: I'm not acquainted with that term.

DR. COULSTON: These are the little dots that appear in certain nutritional dyscrasias and are also characteristic of some drug toxicities. There was no visualization of any inclusion bodies?

DR. FISCHER: No, I reviewed the slides. Dr. Swisch, a researcher from the University of Rochester, has also reviewed them and neither of us have found any inclusions of any kind. The only morphologic changes were prominent aniso- and poikilocytosis in the one man who showed hemolysis in GT-VII. Crenation was a very big finding. This does not appear to be a slide artifact.

DR. COULSTON: With some drugs such as chloramphenicol it's quite common to see simple anemias which are described clinically as a drop in red blood cells. As you know, we very often predict this by using iron uptake studies. Were iron uptake studies done in any of these people?

DR. FISCHER: No, the iron uptake studies were not done.

DR. COULSTON: Wouldn't this be a very important thing to do?

DR. FISCHER: Yes, I think iron uptake studies would be. Operationally, though, it's very difficult to get too many studies done in the immediate preflight and postflight interval.

DR. COULSTON: I would think this is more important than doing the Chromium studies.

DR. FISCHER: No, because we had to demonstrate objectively first of all that there was indeed a problem. This was not very well accepted initially.

DR. COULSTON: You have your reticulocyte counts, which had to be accepted, whether you did the Chromium study or not.

DR. FISCHER: There's one other comment I think needs to be made. We've done a subsequent oxygen study and the study was monitored quite closely as far as hematological parameters were concerned, and oxygen does not seem to explain all the findings that we find inside the Gemini space capsule. So, although oxygen may be a component, it appears at the moment not to be the entire story. This is a well controlled oxygen study we just completed.

DR. COULSTON: I suggested two possibilities, some kind of a chemical or some nutritional factor. We'll let it go at that.

CAPT. KAPLAN (Toxic Hazards Division): I'd just like quickly to clarify a few points. First, Dr. Coulston, the search for inclusion bodies in this particular work has usually meant search for Heinz bodies which are one of the characteristic findings of oxidative hemolytic anemias. This observation is based mostly on work done with chemical and pharmaceutical oxidants like Primaguine and others which usually characteristically cause the appearance of Heinz bodies as intracellular inclusion bodies. They consist of denatured protein, thought to arise from the oxidative degradation of hemoglobin. Not only in these studies but also in other land-based studies such as those reported earlier today, searches for Heinz bodies have not shown any to appear in the oxygen exposure situation. Secondly, the situation with chloramphenicol, which you alluded to, is clearly known to be a bone marrow effect and a defect in production. Dr. Fischer's data suggest that, on the basis of his Chromium studies, there is no suppression of production of red cells. However, other land-based studies, some of which have included iron utilization studies on both animals and humans, have variously suggested that there may be a transient slight suppression of erythropoiesis. I think you have been talking about red cell production and Dr. Fischer has been talking about red cell degradation. In this case, we are more interested in the degradation because although there may be a slight suppression of production there is good evidence that there is not a marked decrease in production.

The only other point I want to make is to clear up the use of this word "sequestration". Dr. Fischer has pointed out that the deficit in circulating red cell mass does not derive from missing cells that are sequestered at the time their measurements are done. However, this does not rule out the possibility that transient sequestration occurred during the flight or during reentry. For example, splanchnic pooling of blood resulting from cardiovascular dynamic changes could lead to a stagnant hypoxia which would cause those cells which had been sequestered to lyse. Then, by the time the measurements were made on recovery, all the cells would again be back in the circulation but those which had been transiently sequestered during the flight would have been lysed. The fact that sequestration is not present during the time of the studies (which is after the recovery of the astronauts) does not eliminate the possibility that the hemolysis is on the basis of sequestration which transiently occurred due to the changes in vascular dynamics during the flight.

DR. STOKINGER (U. S. Public Health Service): In the light of this hemolytic anemia, there's an interesting possible side issue, and that is this: in the destruction of hemoglobin to urobilinogen, some Swedish work has recently shown that for every molecule of hemoglobin destroyed, there's a molecule of carbon monoxide produced. So this might account for some of these high values of carbon monoxide in the space cabin that were reported yesterday.

DR. ROTH: I tried to corner the Russian visitors at the Aerospace Medicine Association meeting to ask them about their data on this point since they use an air atmosphere. I thought it would be interesting to get some hard numbers, but the only fact I could get was that some of their people had as high a decrease in red cell mass as we found. Others had much less. The individuals I questioned were not familiar with the techniques of measurement used. I think this is the only comparative data that we have from across the sea.

The next question has been asked by several and I'll combine it with other questions directed to Capt. Wolfle. "What was the mean and maximum background noise level in the exposure and what thoughts does Capt. Wolfle have on the methods of evaluating human performance during artificial environment exposure?"

DR. BACK (Toxic Hazards Division): I'll probably have to answer the first one myself. During the experiment which Capt. Wolfle was talking about, it was about 105 to 110 dB in the center of the Dome. Out at the cages, which are on the periphery out toward the windows, the noise level is about 95-98 dB. After some changes we've got those way down now to around 80 to 85 dB. Even 5 dB is a great saving because we've got very small speakers in there and the masking effect from noise is right at the cps that we're using. In other words, the biggest noise level is right around 1500 to 2000 cps and that's the sound these monkeys are listening to. Now, as you'll see them today working, no more problems whatsoever. They can hear it, loud and clear. In summary, noise level is pretty loud. Still, these animals do not seem to have had a decrement in hearing.

DR. ROTH: Now the second part of that question: thoughts on evaluating human performance during artificial environment exposure - does anyone have any thoughts on that, other than having the individuals do the tasks routinely assigned within a simulator?

DR. HENDLER (Naval Air Engineering Center): We've found in our studies at the Aerospace Crew Equipment Laboratories in Philadelphia that one of the ways we could get some reliable performance from subjects confined in the chamber for long periods of time was to have some of these subjects believe naively that they were actually controlling the environment in the chamber. In one case, I think, a big gong went off when these subjects, who were performing their various tracking and control tasks, sort of "goofed" off and allowed things to get out of hand. By this loud noise being produced at these times it woke up some of the other people who were sleeping in the chamber and the ire of the social environment concentrated on the fellow who was supposed to be performing his task. This was one way of forcing these people to do their utmost and keep them motivated because on these very simple type tasks that the psychologists usually rigged up, we have found that the people soon became bored and really didn't concentrate on doing a good job.

DR. ROTH: Thank you, Dr. Hendler. Any other comments on this point?

DR. DANON (Weizmann Institute): I would like to draw attention to something that is probably exaggerated, but the possible mechanisms of sequestration of red cells that Capt. Kaplan has described must draw attention to the fact that red cells are not sequestered only in the spleen. In similar experiments, sequestration of red cells has been seen to result from experimental traumas or traumas that occur clinically. Recent indications of some difficulty in certain reflexes arising in traumatized humans indicated that punch-drunkenness symptoms can occur about 24 hours after trauma. I think it would be worthwhile looking in the humans and experimental animals submitted to these experimental traumas to see whether there is any sign of sludging in the conjunctiva or any other capillaries and try to test for very fine reflexes.

DR. ROTH: Thank you. I think we'd better go on to the next question. This is addressed to Dr. Riesen and I think it is a rather interesting point: "Cellular biochemical changes associated with oxygen effects appear to be related to uncoupling of oxidative phosphorylation. It is known that thyromimetic or thyroid drugs will produce similar effects to those you have reported. Therefore, has any work you know of been done or directed toward measurement of thyroid activity following oxygen exposure? That is, will oxygen exposure change the uptake and/or release of thyroid hormone or will it alter the release rate of TSH from the pituitary?"

DR. RIESEN (IIT Research Institute): I'm not aware of any work directed exactly to that area except the work of Dr. Felig, which preceded ours. By lactate administration he could delay mortality and reduce the numbers of animals dying. There was some thought that this might be related to a thyroid-like effect. This possibility was eliminated by experimental observations. Perhaps Capt. Kaplan knows more about the details of this work. I was convinced in reading the papers and discussing this with Dr. Felig that the possibility of thyroid effect had been eliminated in this particular circumstance. I do think that additional work in this area may very well be indicated.

DR. ROTH: To this point, during World War II, people working in high pressure oxygen showed that thyroid hormone will intensify symptoms and thyroidectomy will relieve symptoms. I know of no other specific work along this line.

DR. RIESEN: I have only one comment. That is that we are talking about general metabolic stimulators and depressors as, for example, in hypothermia everything slows down and it would be natural that all rate phenomena would be decreased. We have to consider specificity or an oxygen effect here in light of these general metabolic stimulators and depressants.

CAPT. KAPLAN: I was just going to say that everything comes full cycle here and again the morphology and the biochemistry correlate because the findings of electron microscopy in the liver, namely, the mitochondrial swelling, were initially suggestive of a thyrotoxic effect. Dr. Felig did initiate studies to determine what the activity of thyroid hormone was in rats exposed to pure oxygen at one atmosphere and found, much to his surprise, that rather than a hyperthyroid state, there was a hypothyroid state (at least on the basis of measurement of protein bound iodine in the blood). Initial attempts to clarify this were based upon investigation of the activity of thyroid hormone oxidase and transaminase. It was thought that perhaps oxygen was increasing the activity of these enzymes causing excess removal of thyroid hormone from the blood. This has not been proven to be so and now, on the basis of the biochemical work reported here, we think that more likely what is happening is that the same breakdown in oxidative phosphorylation and uncoupling that we see in the liver is occurring in the thyroid gland, leading to a decrease in production of thyroid hormone rather than an increase in breakdown. So, I think we can pretty clearly say that the uncoupling that we see is not a thyrotoxic effect although it may be similar to it.

DR. FAIRCHILD (U. S. Public Health Service): That was my question. I wanted to make a point here. Have you done metabolic studies? Are these animals hypo- or hypermetabolic? I bring this up again because with ozone, thyroid hormone increases the toxicity terrifically and we thought of the possibility of a metabolic

ect such as uncoupling oxidative phosphorylation; but when we use 2, 4, Dinitro-
nol, we get no effect at all. My question is whether these aspects had been
ked into because it would explain possibly some of those changes in the sub-
lular fractions mentioned yesterday by the electron microscopists.

DR. RIESEN: I think when we talk about metabolic effects we immediately
e to narrow them down to something highly specific both in a morphological and
a biochemical sense (because these cannot be separated). When we prepare
ochondria, our design philosophy first of all is to work out the best techniques
isolating mitochondria so that we can measure their most rapid, their most
ensive capability, whatever this is, with regard to metabolism. No one has
r seen mitochondria as they lie in the cell. I don't think that any electron
roscopist will be able to tell us just what a mitochondrion looks like in a cell.
guess is that it's probably, more than anything else, like an accordion, because
know that the bellows action of the mitochondria inside a cell is ATP and calcium
l potassium linked. So it is a very hazardous business to extrapolate from either
electron microscopist's findings or the biochemist's findings alone to the
lular situation. All we are doing is lifting the mitochondria out and trying to
tect them best as we can biochemically and show what they are capable of doing.
the cell the mitochondrion is sort of coasting along. In periods of stress, energy
required for anything that the cell attempts to do as an adaptive mechanism.
hat energy is not available, as occurs in vitro after the exposure period, then
; just not there.

Let's distinguish one other thing. In mitochondria and cell homogenates,
n whole cells, QO_2 measurements might be the closest approximation of the
eral rate of the metabolism. Certainly, if the oxygen uptake is high, we have a
h rate of general metabolism. However, if it is high and very little of the
gen shows up as high-energy phosphate, this now is uncoupling. Oxygen, let
now realize, has only one function in mammals. Everything else I feel is
ondary. Really, basically, the role of oxygen is simply to produce high-energy
osphate bonds from the food we eat. The efficiency of this mechanism is what
PO ratio very basically measures. This is general in all cells, except for the
throcytes which are very unusual cells in this regard and are a problem all of
ir own. I don't know if this answers your question.

DR. FAIRCHILD: Yes, but I still don't know whether these animals are
er- or hypometabolic under 5 psi oxygen.

CAPT. KRASNOGOR (USAF School of Aerospace Medicine): We have done
Rs on the volunteers in the 5 psia, 100% oxygen run and found no changes in
al metabolic rates.

DR. ROTH: I think we'd better go on to the next question. Unfortunately
key reaction involved here, the actual biochemical mechanism of oxidative
s phosphorylation, how oxygen interacts with the phosphorylating mechanism, is
exactly known. Once we understand this we'll have a better handle on how
gen toxicity is affecting this process.

The next question was stimulated by Mr. Saunders' excellent review of
dichloroacetylene problem. It says, "Does trichlorethylene (and its related
composition products) constitute an Air Force problem and what would be the

advantages and disadvantages of a study in chimpanzees with dichloroacetylene and a conditioned response? What other studies might be fruitful?" This is open to general discussion.

MR. SAUNDERS (Naval Research Laboratory): I think it's an important problem to the Air Force. I think it would be nice if they could do some toxicological studies on this and other contaminants using as a test animal perhaps human volunteers. Dr. Stewart at Dow Chemical has long used employees of Dow Chemical as volunteers for studying the toxicity of various chlorinated hydrocarbons they manufacture. Here, in the case of dichloroacetylene, we could bring these people up to the first indication of a symptom and then stop the test. It would be important to know at what low levels these first symptoms appear. Capt. Siegel's work right now with rats shows that the rats actually seem to thrive on concentrations of 5 ppm in air. They then increase the concentration up to about 20 ppm and the rats look happy, but later, on necropsy, these rats show extensive liver damage. It's hard to tell with rats when they're going to have headaches or some of these other odd symptoms that the humans experienced.

DR. HARRIS (NASA, Manned Spacecraft Center): I would like to comment on that. I think Mr. Saunders' contribution here is bigger than the question of trichlorethylene and its decomposition products. Trichlorethylene as such may not be any particular problem to the Air Force and NASA. On the other hand, the demonstration that a failure in the environmental control system (and, at that, what does not appear to be a large change in terms of failure) can result in the production of new toxic contaminants in the atmosphere is undoubtedly the most important contribution of this and something we should all bear in mind.

DR. ROTH: I think we can go on to the next question. This is addressed to Dr. Harris and is along the very same lines. "Has inclusion of flammability data such as spontaneous ignition temperatures, flame spread-rates and combustion products for parts and materials in manned spacecraft been considered in the data retrieval program?"

DR. HARRIS: The flammability data in terms of autogenous ignition is included in the data retrieval system. The nature of the thermal decomposition products is not yet. One of the problems here is trying to define thermal decomposition products; as soon as you change your conditions slightly, the products are grossly altered so that you're entering into a highly complex area if you are going to attempt to define all of this and include it in a system.

DR. ROTH: Thank you. This is directed to Capt. Kaplan. "It has been shown by Haugaard and others that glyceraldehyde-3-phosphate dehydrogenase can be inhibited by a 15-minute exposure to oxygen at one atmosphere in vitro. Do you think that inhibition of this enzyme in vivo could be a factor in the red cell hemolysis seen during prolonged exposures to oxygen?"

CAPT. KAPLAN: I can make this very brief and say yes. As I tried to indicate yesterday, this step precedes all the steps in the red cell that are responsible for the production of ATP; it is also a step responsible for the production of NADH. Both the presence of adequate amounts of ATP and adequate amounts of reduced pyridine nucleotide are essential for the maintenance of the integrity of the red cell (as of any other cell). Unfortunately, as Dr. Riesen points out, in vitro

tests just test the enzyme activity itself and do not take into account various adaptations and interactions that can occur in the in vivo state. I think this certainly is one of the enzymes which needs to be considered in the etiology of hemolysis but I don't think any really good determinations of this have been done yet.

DR. ROTH: We'll go on to the next question then. This takes us back to red cell metabolism. "It has been suggested that although the morphologic changes seen in the liver by electron microscopic examination after oxygen exposure probably do not represent detrimental changes, they may reflect alterations in the liver's detoxification mechanisms. In this regard, what potential toxicants or contaminants would be most profitably investigated in future liver electron microscopy and cellular biochemistry studies? Does anyone know of any concrete evidence that 100% oxygen at 5 psia is unsafe for humans?" I think we can add to that the kidney problem. We have the chance of studying both the liver and the kidney, doing some rather sophisticated metabolic studies, trying to correlate these microscopic changes, and I wonder if someone would rise to the occasion and suggest what sort of thing should be done with these two organs and, finally, any concrete evidence regarding the human problem with 100% oxygen. Any liver or kidney physiologists who'd like to get a few words in?

CAPT. KRASNOGOR: I'm no liver-kidney physiologist, but in humans exposed to 100% oxygen at 5 psia, we did elaborate renal function as well as all the liver function tests that are known to man and haven't been able to demonstrate any changes.

DR. THOMAS (Toxic Hazards Division): Since we're going to publish the proceedings of this Conference, let's set one thing straight right now before some news leaks out and becomes misinterpreted. I don't think anybody has got enough evidence at the present stage of the game to imply the possibility that the 5 psia oxygen atmosphere (as it's used presently by NASA and the Air Force) is unsafe for mission durations which we are contemplating. This is very important; I want to get this clearly across. Since we have 56-day exposure, or similar long studies at the School of Aerospace Medicine with human volunteers who are evaluated in the best clinical manner, and we can't find anything wrong with them, and now we can add to these the result of 8 months' continuous exposure of large numbers of animals, and they are clinically well (granted we have found some marginal histological changes), we can extrapolate with reasonable assurance that 5 psia oxygen will be definitely safe for at least 30-day, if not for 90-day missions. Let's also keep in mind that if there are any changes, as you've heard the pathologists say, they are very likely to be adaptive in nature, or if they are pathological in nature, they are probably at the reversible stage. Now, if anybody wants to sink his teeth into that, he's welcome.

DR. ROTH: Any biters?

DR. RIESEN: I couldn't agree more fully with everything that has been stated. I'm no physiologist, I'm no pathologist, no pharmacologist. I would like to suggest, however, that perhaps we haven't really gotten into the black box. Maybe we're looking at what's going in and we're looking at what's coming out. Biochemists were at this stage decades ago and it wasn't until they found methods for preparing pure mitochondria out of the cell, pure mitochondrial subparticles and many other preparations of this sort, and it wasn't until the physiologists looked

at muscle-nerve preparations, it wasn't until they were able to perfuse organs, it wasn't until they were able to take the heart out and look at it as an organ by perfusion that they began to understand mechanisms. I'm suggesting that perhaps some of these techniques might enable us to determine the effects of particular concentrations of oxygen, of various pharmacological toxicants and atmospheric intoxicants upon specific organs. Certainly it is very difficult to get into the animal and measure the amount of oxygen that's being delivered to the mitochondrion. I've seen calculations made in this regard reported in the New York Academy Symposium on Hyperbaric Oxygen, and they're probably the best that can be done. I wonder if we don't need some biological preparations which will give us a screening method for the organs. That's the only suggestion I have in this regard.

DR. ROTH: There's one other point with respect to pulmonary testing. A question had been asked of me and several others as to what sort of test can one do in animals to study pulmonary function, to correlate the changes one sees in the membrane with pulmonary function changes. We were recently visited by a Professor of Pathology at the University of Muenster in West Germany who has worked out a technique of studying in vitro postmortem lungs and has applied a battery of pulmonary function tests to the postmortem lungs which give a superb correlation with the pulmonary function tests during the immediate pre-mortem life of the individual. I think techniques of this sort might come in very handy. You can get maximum breathing capacity evaluation, diffusion problems, compliance, and various other factors can be studied almost as well as they can in vivo. I think by using techniques of this type one might be able to get a better correlation between the pathological changes seen in the lung and actual functional equivalents.

DR. VORWALD (Wayne State University): May I comment on this? For years we have been concerned with this problem of doing pulmonary function studies in animals and man. With respect to experimental animals, the specifications are that the study shall be applicable to all kinds of animals, done repetitively during the various periods of the day, that they will not impose any undue stress upon the animal, and that they will be of a high degree of validity. In consequence of this, some 5 years ago we developed pulmonary function studies for all the dynamics, all the volumes, inhalation-exhalation, vital capacity, forced vital capacity on both inhalation and exhalation and flow rates both on inhalation and exhalation, and maximum breathing capacity. All this can now be done with the new tool which was developed, namely, capacitance respirometry, eliminating, therefore, all masks, all boxes, all tubes, all insults to the animal. The same thing applies to man. The animal is merely placed in an electronic field with but a small wire attachment to the tail or the ear, or human subjects stand on an electrode in stocking feet, and we can monitor all the volumes of the lung which I have mentioned, in a room at any distance. There is no impediment of mouthpieces, masks, resistance of tubes and all these things. This can all be done in a gassing chamber or the animal can be in an altitude chamber. You can get the baseline before he's ever exposed and you can follow, monitor, his pulmonary function with respect to volumes as he is inhaling this air at different concentration. Diffusing capacity of the lung can be obtained in these animals and in man too by putting in an indwelling catheter; and you can draw blood ad lib and it can be correlated immediately with the character and nature of the volume changes. This is merely a comment. It has bothered us as it has bothered you, but I think finally we have a method which is applicable and I invite you to try it. Results can be put on tape if you are doing a multitude of tests, a multitude of animals, a multitude of men,

nd at the end of the day's run, hand the reels to the computer. The next morning you can have the values, that is the volume values with respect to tidal air, vital capacity, maneuvers, maximum breathing capacity and all the others.

DR. GROSS: I would also like to make a comment in regard to methodology in examining the lungs after an exposure of any kind. In looking for a no-effect dose, in examining the lung histologically, it behooves one to look in addition to sections stained with hematoxylin and eosin also at sections stained for the argyrophilic stroma (the reticulin stroma). I have found this method to be a much more delicate and sensitive method for picking up abnormalities than merely looking at routinely stained sections. I think it's a must.

DR. SCHAEFER (U. S. Naval Medical Research Laboratory): In partial answer to Capt. Kaplan's question, I'm wondering whether ring hydroxylation could not be checked out as part of the detoxification mechanism of many compounds?

DR. FAIRCHILD: Dr. Thomas, do you wish to completely discount the findings in dogs after 90 days at 5 psi, this thickening of the alveolar membrane which is seen to persist for 40 days after this exposure? Pulmonary function I do not believe will detect anything that can occur along these lines, possibly diffusion of carbon monoxide uptake would. I just wanted to have a comment on that. Could it lead to something further?

DR. THOMAS: I don't like to ignore pathology. All I'm trying to say here is that these changes are probably reversible. Moreover, the morphometric analysis of electron microscopy findings by Dr. Kistler has not shown significant thickening after 8-month exposure. We don't know enough about long term effects yet, but when we go to longer duration missions they might very well become important. I'm just remembering what Dr. Vorwald said yesterday. As we go into 1-year and 2-year mission duration for missions like Mars fly-by and so on, I think we will have to be very careful to make sure that we are not, in effect, creating an occupational hazard for our astronauts. I think this is the time when we should keep our animals for survival times, for observation of accelerated aging processes, and observe them and evaluate them very, very carefully. But from a 30- or 90-day mission I don't think anybody will come back with an irreparable pulmonary or other pathology.

DR. VORWALD: I'm very much concerned about the deposition of collagen in the alveolar septa. I am not convinced that alveolar collagen can completely and totally resolve without leaving in its wake an impaired alveolar septa. I'm very much concerned about this, although from a conventional, histopathological point of view, it can be seen to regress. But yet, we can do pulmonary function studies, detailed diffusion capacity on individual subjects and we find they have a diffusion impairment. The explanation of it is not known but I merely present to you the thought - I think it's reiterating what Dr. Thomas has said - let us not think that collagen degeneration of the alveolar septa regresses without leaving in its wake an impaired septa.

DR. FAIRCHILD: You have all this beautiful work in electron microscopy. Has anyone attempted to find anything in cardiac tissue? The reason I bring this up is because with very low levels of ozone a group of workers in the Netherlands has

recently reported necrosis in myocardial tissue. Of course, ozone is a much more toxic material but possibly some mechanisms are basic, relative one to the other. With about 0.3, 0.2 ppm of ozone for as short a time as 30 minutes in man, rabbit and mice, they can indeed demonstrate necrosis in myocardial tissue.

DR. THOMAS: Did you see some myocardial changes, Dr. Harper? There's something in the back of my head that that was with light microscopy.

CAPT. HARPER: We had one instance in the 90-day oxygen exposure of systemic necrosis involving kidney, liver, and heart. This was the only case of this nature. It appeared to be more likely on an infectious basis than anything else. I would say in regard to those alveolar septal changes observed in the lung of dog in the 90-day study that the major problem was that it occurred quite early, after as little as 14 days, but then was not present in many of the dogs at 60 days. It was present in only one dog at 60 days and in all the dogs at 90 days. I cannot say whether or not adaptation is occurring during the exposure, but the fact that it was not observed much later in the 235-day exposure, and its appearance, disappearance and reappearance during a rather short 90-day exposure would indicate to me that it is more likely factitious. I don't think we have any kind of uniformity in this species to indicate a direct toxic effect of this atmosphere.

DR. SCHAFFNER: I'd like to make two comments. First, dealing with the problem of the lung and fibrosis: this year at the Federation Meetings, we reported studies done on animals exposed for 10 days at 700 mm pure oxygen. These animals showed more or less an extension of what Dr. Kistler showed, and we felt this was an adaptive change occurring probably to protect the rest of the body from hyperoxia. One of the things that bothered me was what happens when you suddenly bring such an animal or individual back to ground level ambient air? It seems to me that while they are at altitude or in flight they should be fine and protected. Now in answer to what Dr. Thomas said about the safety of the 5 psia oxygen atmosphere, certainly it looks as though it's perfectly safe. It's a lot safer to breathe oxygen at 5 psia than to take ten drinks a day for ten days, at least as far as the liver is concerned. We have studies on this demonstrating that the changes are more severe after alcohol than after oxygen. We've learned something from alcohol which I think we have to learn from oxygen too and that is, if an individual is drinking alcohol and gets carbon tetrachloride he gets very sick. Now, the question comes up, which of the intoxicants would we be willing to study from a morphological point of view? In answer to Dr. Kaplan's question, and seeing the long list presented yesterday of all the chemicals that the individuals might come in contact with, there was none that I could really pick out that I would like to study. Since the only one that seems to have caused any clinical symptoms is trichlorethylene I think that its degradation products are the ones we should go after.

DR. ROTH: There's one other problem here and this is what happens to an individual who gets exposed to hypoxia, after having his lungs damaged somewhat by 5 psia 100% oxygen, and I think this would be something worthwhile looking in from an emergency point of view.

DR. THOMAS: We did such experiments. We exposed animals to high concentrations of oxygen near ambient pressure to create that typical lesion and then brought some of them back to ambient air immediately and the rest of them went to 5 psi oxygen environment. The latter seemed to have had a protective effect. May we get Major Robinson to answer this?

MAJOR ROBINSON: We felt there was after exposure protection in 5 psia oxygen as I tried to point out yesterday. You may recall the slide where we brought our monkeys out of the chamber to ambient air before they were killed. There was an extreme amount of exudation and hemorrhage that we felt was a terminal event while in the other animals killed in the same environment to which they'd been exposed, the lungs were free of these lesions. So I think it's quite reasonable to expect a drastic or a fatal terminal event in animals or possibly in people returning to ambient conditions following exposures to high concentrations of oxygen at near ambient pressure.

DR. ROTH: Along this line, Rahn using, I think, about 200 mm of mercury of oxygen found that animals born in this environment, returned to ground level, and then again returned into this environment died soon after. This phenomena has never been really explained. He had a lot more atelectasis than I think we tend to see with the 5 psi.

CAPT. KAPLAN: I'd just like to say on this question, which is very pertinent, let's not confuse the oxygen exposures at one atmosphere and close to that with the 5 psia situation. Now, remember that the lung damage that we see even on the ultrastructural level at 5 psi, for either very long or very short durations of exposure, is minimal. If you remember Dr. Kistler's work, it was not even visible morphologically with the electron microscope. It was only on the basis of morphometric determination that it was suggested there was some change in the thickness of the barrier and that was a reduction in thickness. The slight changes that were seen in histology in the dogs at 90 days, thickening of the membrane, I think, as Dr. Schaffner suggests, may well be a protection. Pathology here on the ground is not necessarily pathology in the pure oxygen environment. This may be just what the animal needs to induce a partial diffusion block and prevent him from having hyperoxia in his blood. A pertinent question is, does this go away when the animals come back to the ambient environment and do not need a diffusion block any more? We know at one atmosphere it doesn't. You take monkeys and expose them to one atmosphere; they can go for 4 or 5 or 6 days and look very well in the pure oxygen environment, but within 3 minutes after you take them out of the dome they're dead, because they've reached the point where they have so much pulmonary damage that they're dependent on 100% oxygen to get even minimal levels of arterial oxygen saturation to keep them alive. I think the question is, do these minimal changes occurring at 5 psi, which is what we are really interested in, go away on return to ambient? We have approached this question precisely because all the work we have done recently has involved not only examination of the animals after exposure, but also examination after returning them to the ambient environment and keeping them that way for about a month. A lot of this work including pulmonary electron microscopic studies of lungs of animals returned in this way is presently being done. We have no results yet but I think we'll have very specific answers to this question; namely, do these changes which do occur minimally at 5 psi in oxygen go away completely after return to the ambient environment or do they leave some residual damage which, although protective in oxygen, is detrimental when you return to the ground?

DR. ROTH: Along this line, Dr. Back asked me yesterday about diffusion capacity studies in humans exposed to 100% oxygen. In 1961 John Ernstein at Farnborough did a study. He exposed individuals to 100% oxygen for 3 hours and did diffusing capacities and found a less than 10% reduction in diffusion capacity.

He repeated the same work with 50% oxygen for 3 hours and found no change. So there might be a significant factor in humans. Of course this was at higher pressure than the 5 psi, 100% oxygen, but I think it is worthwhile following through.

DR. HENDLER: In one of our most recent studies we exposed six subjects to 100% oxygen for 20 days at 5 psia, and during regular intervals, I don't recall what they were right now, but at regular intervals during the exposure, both before and after, we measured diffusion capacity of the lung and this was done in collaboration with Dr. Forcer of the University of Pennsylvania. We found no significant changes.

DR. BACK: This is while they were at altitude?

DR. HENDLER: Yes, both before and while they were at altitude and after they returned to sea level.

DR. BACK: Good. This is fundamental. You see, diffusion capacity certainly has a great deal to do with how much compound the animal or man finally gets into his system. I have never had any data that tells me just exactly what is going on dynamically in the lungs while at altitude. This is the first indication that I know of that it's being done at least.

DR. HENDLER: I could just say this, this report has recently been completed and it has been actually issued to NASA, who funded this particular study. So it should be available very soon. (Dr. Hendler later retracted this statement. They have not measured diffusing capacity while at altitude. Ed.)

DR. ROTH: There's one more question along this line?

FROM THE FLOOR: I've been rather hesitant to speak up because most of the work we're doing at Ames is rather new. We've only been working on the problem for about the last 6 months. We've been interested in pulmonary physiology after exposure of animals to oxygen concentrations for long periods of time; so we've been measuring a standard battery of pulmonary measurements in rabbits after they've been exposed to oxygen for as long as 6 months at 600-450 mm Hg pressure. We are also doing cardiac catheterization in dogs who have been exposed to oxygen to determine if there are any changes in pulmonary vascular resistance upon exposure to oxygen. I think there is one other researcher in the country making the same kind of measurements and that's George Kidd at Johnsville, who is also doing this type of study. We have found that rats that have been exposed to pure oxygen at 600 mm for as long as a month developed this typical symptom of thickening of the alveolar wall and it persists for as long as a month after they are taken out of the oxygen. It is interesting that when you do compliance measurements on these rats, the pressure involved in inflating of the lung is markedly higher than in the control rat. This persists for as long as a month after the rat is taken out of oxygen. We have developed a good deal of pulmonary physiology measurements in rabbits by using a whole body plethysmograph and we're presently making measurements in pulmonary function changes in rabbits after exposure to oxygen for a long period of time. The rabbit is a very funny animal. It's extremely sensitive to oxygen. Probably the most sensitive of all. We've had a good deal of difficulty keeping rabbits alive after we've taken them out of oxygen.

DR. FAIRCHILD: We have some beneficial aspects of this thickening at least with a very slight inhalation of ozone. You produce thickening of the alveolar membrane, these animals then are resistant to multilethal doses of phosgene, nitrogen dioxide, nitrosyl chloride, and many other edemogenic agents, other than say adrenalin, which has its effects by pressure change.

DR. COULSTON: I'm very much interested in this so-called cardiac - I don't want to say "necrosis" - but "changes" that have been observed. I'd like to ask the question based on this premise. It's pretty well established now that changes in the ratios of norepinephrine and epinephrine in almost every species of animal will cause changes in the capillaries with cardiac necrosis. What is the pituitary adrenal axis of these animals that have been studied? Has anybody looked into the catecholamines? Has anybody studied the histology of the heart to see what the relationships are?

DR. FAIRCHILD: I think I can add a little bit to that. The work of Bean and Johnson at the University of Michigan - this has been quite some time ago - and Pershman at Rochester have shown that in hyperbaric oxygen there is definitely a compensatory or emergency excretion of epinephrine and that if you adrenalectomize animals or do a medullectomy you get good protection against the oxygen toxicity, or if you do a hypophysectomy to eliminate thyroid influences, you also get good protection. If you use thyroid blocking agents as we did with respiratory irritants other than ozone, you get a significant protection and, as you well know, thyroid hormone is in some way synergistic with the catecholamine and indolamine effects. Quite a bit of this background work has been done, but it's all been on hyperbaric oxygen.

DR. VORWALD: I know Dr. Thomas is going to ask the question ultimately there's time - where do we go from here? During the course of this entire symposium I haven't heard much about the degradation of endocrine function. Are we paying enough attention to the endocrine glands? Are we paying enough attention to the adrenal? I'm particularly interested in the pancreas, the pituitary, and the thyroid in all of our studies. I ask the question, is it possible that what we see as manifestations of the toxicity are but a reflection, a mirror, of things going on in the endocrine system?

DR. FAIRCHILD: I have a very strong feeling that the reason that you get a reduction in oxygen toxicity at 5 psi, one-third atmosphere, is that you're just going in the other direction and that the homeostatic mechanisms are much more competent to protect the animal.

DR. ROTH: I'd like to get on to the last question here, which I think is very important. It was raised yesterday and is asked by Dr. Stokinger. "Dissatisfaction was expressed with the value of the results obtained on enzyme activities in the serum of animals exposed to oxygen, and the intention was expressed to resort to punch biopsy of the lung. Omitting for the moment the possible misinterpretation of the serum findings, the question is, how can consistent interpretable results be obtained from punch biopsy when Dr. Robinson showed (as well as others) patchy distribution of injury in the lung and even in different sections of the individual animals? I would like to expand this and recommend other procedures, and I think could also extend this on to punch biopsies mentioned by other authors. What can be gained and how does one go about it?"

DR. BACK: I'd like to state something first. I may have been misinterpreted yesterday. I didn't mean to imply that I thought serum enzymes or any other serum parameter that we're studying were worthless. I just meant to imply that we couldn't detect early changes in serum. By the time you get a serum change, you've already got a pretty full-blown change in tissue levels. I suggested if we want to look at early changes we're going to have to go to punch biopsy. On the other hand, we're never going to stop doing all these tests because we need the data badly just to see how the animals are doing. It's a good way of knowing whether the animal is at least well or not. When we get these animals in, many of them have reversed AG ratios, SGOTs, SGPTs, and LDHs may be high. If we keep them around for a month or two and after we put another hundred dollars worth of care and medication in them, they become real fine animals, and all of their parameters are back in their normal ranges. This is the only way we have of knowing where they are to begin with. Punch biopsy, I think, is probably going to be absolutely necessary if we want to get early changes, if we want to see it at its very earliest stage, because by the time we do get a reflection in blood it's already happened.

CAPT. KAPLAN: I want to correct what I think was a misimpression. I don't think we are suggesting punch biopsies of the lung. Certainly our group doesn't intend to do that. I think for the reasons stated, in addition to other reasons, random punch biopsies of the lung would not necessarily give us what we want to know. However, to answer the other part of the question, the liver and the kidney, although the lesions may be patchy in distribution in terms of comparing one mitochondrion to the next, or one cell to the next, within the size of a needle biopsy of tissue, distribution is pretty even. We have found by doing several biopsies on the same liver, or the same kidney, different parts of the tissue look pretty much the same. This is why we are now doing percutaneous biopsies of liver and kidney because of its advantages, not the least of which is that it allows us to do serial biopsies on the same animal without even anesthetizing it (just using a local anesthetic). Each animal then acts as his own control and we can get very nice serial determinations of the evolution of the lesion. This is not true of the lung.

DR. BACK: I'd like to make another comment on that. I want to make perfectly clear that I think this is the only way we can get enzyme changes. These are chemistries I'm talking about, not morphological changes necessarily. The other thing is I've heard different people talking about some of our data. As you see it presented, it's all lumped together and averaged out. We have a real problem of presentation. Every animal in our laboratory is treated as his own control. I don't want you to go away from here thinking we're just lumping 16 dogs and 17 monkeys and making averages of them. That's the way most of the data were presented, however. We are treating each animal as his own control and following him individually. The problem you get into is if you don't treat them individually you sometimes see statistically significant grouped averages which are not really significant at all if you look at each individual in that group. You can come away in real bad shape if you don't treat your animals individually, and we are.

DR. HARRIS: I'd like to ask a question regarding the punch biopsies. What enzymes are you considering in particular? The ones you are talking about in terms of serum and plasma reflect gross tissue damage and leakage so that you are going to be concerned with a completely different set of enzymes if you are going into tissue biopsies.

DR. BACK: Yes, I think this depends upon what compound we are talking about. In other words, I don't think we can at this moment pick any set of enzymes and say 'these are the ones we have to use'. I think we have to follow our nose and look at mechanisms.

DR. HARRIS: The point I wanted to make is that, on the basis of what was presented, the changes which you were looking for probably would not be evident until the animal was pretty far gone.

DR. THOMAS: I think the point Dr. Back is making is that by the time we can pick up serum enzyme change, I'm sure we will have enough morphological change even for light microscopy. Let's face it, serum enzymes in general are not a sensitive method for early indication of damage but they are very necessary to follow the status of the animal.

DR. ROTH: This has been the experience in the radiation area. I know at Lovelace we have an inhalation study on fallout materials. The animals get massive doses of fallout isotopes and are followed along with serum enzyme studies and they don't show anything until it's quite obvious they're moribund. We've gone to punch biopsies focusing on those enzyme systems that tend to be most sensitive to radiation.

DR. COULSTON: Biopsy is not a very difficult procedure. Routinely in all monkeys we do the following: liver biopsies, intestinal biopsies at two levels, fat biopsies, kidney biopsies, and testicular biopsies. We also do this in man when indicated. We do not do lung biopsies because we agree it's difficult. We often do bronchoscopy and you can find a great deal that way. There's no mysterious thing about doing these biopsies. Many of the ones we have just described have been done routinely in hospitals and medical colleges. The use of indwelling catheters is a very great advantage. There's no great surgical problem to put an indwelling catheter into the splenic vein or portal vein, or the hepatic vein. You can isolate on an intact unanesthetized animal the liver, if you will, and obtain control blood and blood after giving compounds. I think we tend to make a fetish of doing a liver biopsy in man. It's not a dangerous thing any longer. It's done in every hospital in the country when indicated.

DR. MAC EWEN: I'd like to make one comment about the serum enzymes. In the 90-day threshold limit value experiment with ozone at ambient pressure air, one dog out of the eight died on day 30. That same morning he had been sampled and his clinical chemistry and hematological parameters were determined. The dog showed no indication of injury whatsoever, looked apparently healthy, and had not lost weight. That same evening the dog died. On necropsy there was extensive pulmonary hemorrhage and edema, the typical picture you see with ozone toxicity. I hoped that this would have been covered here today in the pathology presentation. I guess they haven't evaluated enough of the histopathology on these 90-day studies to make comments.

DR. ROTH: Dr. Thomas, would you like to close the forum and meeting?

DR. THOMAS: And so this Conference comes to an end and let me then just ask the question, "Where do we go from here?" It's very obvious that we have just scratched the surface. Another thing which is quite obvious is that we have to

take care of our operational requirements first. We must do lots of basic research yet, but necessarily it will have to be done at a limited pace because there are not that many dollars available and not that many exposure chambers available in this country. I think that we will have to look at the astronaut with the eye of the industrial physician. The things which were brought up at this Conference very well may present themselves as an occupational disease of an astronaut who has been flying long enough hours and has been exposed for long enough time continuously at least to basic space cabin atmospheres alone. If we have an inadequate life support or a fouled up life support system he will be exposed to contaminants also. We are going to do the basic research. I think we learned from this Conference that there are some very good leads here which we will certainly follow up. But when we start investigating these changes, we have to start with high enough concentrations that are likely to produce damage in order to get our "baselines" that we know what we are looking for. This is why you heard so much work presented on oxygen at near ambient pressure. The big moot question is: does oxygen act by the same mechanism when pressure gets down to 5 psia or is it a different mechanism? This is the first thing I think we'll have to find out. Is there truly an adaptation? The thickening of the alveolar wall might be a protective process, but will it disappear after return to normal atmosphere? I think that we will have to look at the hormones, the cellular and subcellular metabolism, and see what we can pick up there. I think there are plenty of leads on pulmonary irritants which are applicable to this area. Oxygen is a pulmonary irritant given enough partial pressure. There is some indication that it might be a mild pulmonary irritant even at 5 psia. So is cigarette smoke, but the question is, where do we quit? There is a mission to be accomplished. It is entirely possible that we will find changes. There might be a permanent 5 or 10% disability after a 2-year flight, but I don't think this will keep mankind away from outer space. So, with that, let me thank every one of you, our wonderful chairmen, speakers, and participating scientists, for a very, very profitable meeting. We hope to see you next year.

DOCUMENT CONTROL DATA - R&D

(Security classification of title, body of abstract and indexing annotation must be entered when the overall report is classified)

1. ORIGINATING ACTIVITY (Corporate author) Aerospace Medical Research Laboratories Aerospace Medical Division, Air Force Systems Command, Wright-Patterson Air Force Base, Ohio		2a. REPORT SECURITY CLASSIFICATION UNCLASSIFIED	
		2b. GROUP N/A	
3. REPORT TITLE PROCEEDINGS OF THE 2ND ANNUAL CONFERENCE ON ATMOSPHERIC CONTAMINATION IN CONFINED SPACES 4 AND 5 MAY 1966			
4. DESCRIPTIVE NOTES (Type of report and inclusive dates)			
5. AUTHOR(S) (Last name, first name, initial)			
6. REPORT DATE December 1966		7a. TOTAL NO. OF PAGES 314	7b. NO. OF REFS
8a. CONTRACT OR GRANT NO. AF 33(657)-11305*		9a. ORIGINATOR'S REPORT NUMBER(S) AMRL-TR-66-120	
A. PROJECT NO. 6302		9b. OTHER REPORT NO(S) (Any other numbers that may be assigned this report)	
c.			
d.			
10. AVAILABILITY/LIMITATION NOTICES Distribution of this document is unlimited.			
11. SUPPLEMENTARY NOTES *Conference was arranged by the Toxic Hazards Research Unit of Aerojet-General Corporation.		12. SPONSORING MILITARY ACTIVITY Aerospace Medical Research Laboratories, Aerospace Medical Div., Air Force Systems Command, Wright-Patterson AFB, Ohio	
13. ABSTRACT This report is a complete compilation of the papers presented and the Proceedings of the 2nd Annual Conference on Atmospheric Contamination in Confined Spaces, sponsored by the Aerospace Medical Research Laboratories and held in Dayton, Ohio on 4 and 5 May 1966. Major technical areas discussed by the invited speakers, members of the Open Forum, and Conference attendees included toxicology of space cabin materials, comparative toxicology and pathology of oxygen, and the effects of oxygen on contaminant toxicity.			

Security Classification

14. KEY WORDS	LINK A		LINK B		LINK C	
	ROLE	WT	ROLE	WT	ROLE	WT
Space cabin materials Space cabin toxicology Oxygen Subcellular biochemistry Space contaminants Pathology Electron microscopy Psychopharmacology Thomas Domes						

INSTRUCTIONS

1. **ORIGINATING ACTIVITY:** Enter the name and address of the contractor, subcontractor, grantee, Department of Defense activity or other organization (*corporate author*) issuing the report.
- 2a. **REPORT SECURITY CLASSIFICATION:** Enter the overall security classification of the report. Indicate whether "Restricted Data" is included. Marking is to be in accordance with appropriate security regulations.
- 2b. **GROUP:** Automatic downgrading is specified in DoD Directive 5200.10 and Armed Forces Industrial Manual. Enter the group number. Also, when applicable, show that optional markings have been used for Group 3 and Group 4 as authorized.
3. **REPORT TITLE:** Enter the complete report title in all capital letters. Titles in all cases should be unclassified. If a meaningful title cannot be selected without classification, show title classification in all capitals in parenthesis immediately following the title.
4. **DESCRIPTIVE NOTES:** If appropriate, enter the type of report, e.g., interim, progress, summary, annual, or final. Give the inclusive dates when a specific reporting period is covered.
5. **AUTHOR(S):** Enter the name(s) of author(s) as shown on or in the report. Enter last name, first name, middle initial, if military, show rank and branch of service. The name of the principal author is an absolute minimum requirement.
6. **REPORT DATE:** Enter the date of the report as day, month, year, or month, year. If more than one date appears on the report, use date of publication.
- 7a. **TOTAL NUMBER OF PAGES:** The total page count should follow normal pagination procedures, i.e., enter the number of pages containing information.
- 7b. **NUMBER OF REFERENCES:** Enter the total number of references cited in the report.
- 8a. **CONTRACT OR GRANT NUMBER:** If appropriate, enter the applicable number of the contract or grant under which the report was written.
- 8b, 8c, & 8d. **PROJECT NUMBER:** Enter the appropriate military department identification, such as project number, subproject number, system numbers, task number, etc.
- 9a. **ORIGINATOR'S REPORT NUMBER(S):** Enter the official report number by which the document will be identified and controlled by the originating activity. This number must be unique to this report.
- 9b. **OTHER REPORT NUMBER(S):** If the report has been assigned any other report numbers (*either by the originator or by the sponsor*), also enter this number(s).
10. **AVAILABILITY/LIMITATION NOTICES:** Enter any limitations on further dissemination of the report, other than those

imposed by security classification, using standard statements such as:

- (1) "Qualified requesters may obtain copies of this report from DDC."
- (2) "Foreign announcement and dissemination of this report by DDC is not authorized."
- (3) "U. S. Government agencies may obtain copies of this report directly from DDC. Other qualified DDC users shall request through _____."
- (4) "U. S. military agencies may obtain copies of this report directly from DDC. Other qualified users shall request through _____."
- (5) "All distribution of this report is controlled. Qualified DDC users shall request through _____."

If the report has been furnished to the Office of Technical Services, Department of Commerce, for sale to the public, indicate this fact and enter the price, if known.

11. **SUPPLEMENTARY NOTES:** Use for additional explanatory notes.

12. **SPONSORING MILITARY ACTIVITY:** Enter the name of the departmental project office or laboratory sponsoring (*paying for*) the research and development. Include address.

13. **ABSTRACT:** Enter an abstract giving a brief and factual summary of the document indicative of the report, even though it may also appear elsewhere in the body of the technical report. If additional space is required, a continuation sheet shall be attached.

It is highly desirable that the abstract of classified reports be unclassified. Each paragraph of the abstract shall end with an indication of the military security classification of the information in the paragraph, represented as (TS), (S), (C), or (U).

There is no limitation on the length of the abstract. However, the suggested length is from 150 to 225 words.

14. **KEY WORDS:** Key words are technically meaningful terms or short phrases that characterize a report and may be used as index entries in cataloging the report. Key words must be selected so that no security classification is required. Identifiers, such as equipment model designation, trade name, military project code name, geographic location, may be used as key words but will be followed by an indication of technical content. The assignment of links, rules, and weights is optional.

AD 646 572

646512

ERRATA - January 1967

The following corrections apply to Technical Report No. AMRL-TR-66-120, Proceedings of the 2nd Annual Conference on Atmospheric Contamination in Confined Spaces 4 and 5 May 1966.

The following pages were misnumbered and are out of order in the text:

Page 202 should be 205

Page 203 should be 202

Page 204 should be 203

Page 205 should be 204

On page 122, the caption for figure 8 should be:

CONTROL LUNG CB. Phase contrast micrograph of thin section.
Note red cells in capillaries and delicate air-blood barrier. X600.

On page 178, paragraph 3 - ref 1 should be figure 1

On page 179, paragraph 2 - figure 1 should be ref 1

Table I on page 260 and Table II on page 261 are in error with respect to the mortality ratios of rats. The fractional numbers depict spontaneous mortality in the total number of animals submitted for histopathological examination. For correct mortality refer to Table I on page 246 and Table II on page 247.

D D C
R FEB 16 1967
C