

AD 646218

**BIOELECTRIC CONTROL OF PROSTHESES**

**RALPH ALTER**

**TECHNICAL REPORT 446**

**DECEMBER 1, 1966**

**MASSACHUSETTS INSTITUTE OF TECHNOLOGY  
RESEARCH LABORATORY OF ELECTRONICS  
CAMBRIDGE, MASSACHUSETTS**

**ARCHIVE COPY**

The Research Laboratory of Electronics is an interdepartmental laboratory in which faculty members and graduate students from numerous academic departments conduct research.

The research reported in this document was made possible in part by support extended the Massachusetts Institute of Technology, Research Laboratory of Electronics, by the JOINT SERVICES ELECTRONICS PROGRAMS (U.S. Army, U.S. Navy, and U.S. Air Force) under Contract No. DA 36-039-AMC-03200(2); additional support was received from the Liberty Mutual Insurance Company.

Reproduction in whole or in part is permitted for any purpose of the United States Government.

Qualified requesters may obtain copies of this report from DDC.

ACCESSION NO.	
0001	WRITE SECTION
000	CONF. SECTION <input type="checkbox"/>
UNANNOUNCED	<input type="checkbox"/>
JUG. INFORMATION	
BY	
DISTRIBUTION/AVAILABILITY CODES	
BIST.	AVAIL. AND/OR SPECIAL

MASSACHUSETTS INSTITUTE OF TECHNOLOGY

RESEARCH LABORATORY OF ELECTRONICS

Technical Report 446

December 1, 1966

BIOELECTRIC CONTROL OF PROSTHESES

Ralph Alter

Submitted to the Department of Electrical Engineering, M. I. T.,  
August 23, 1965, in partial fulfillment of the requirements for  
the degree of Doctor of Science.

(Manuscript received September 28, 1965)

Abstract

Externally powered prostheses have been studied for many years, in efforts to provide more effective rehabilitation of amputees. In order to take advantage of the benefits offered by external power in prostheses, however, the mode of control of the prosthesis by the amputee must also be improved. Conventional control methods require a high degree of mental concentration by the amputee on his prosthesis, because of at least two important factors: (i) the mode of control of a prosthesis motion conventionally is different from control of the corresponding normal action; and (ii) there is no feedback of sensation from the prosthesis to the patient except through the visual sense.

Bioelectric control offers the possibility that control of the prosthesis action can be similar to control of the corresponding body action, which was lost through the amputation. The muscles in the body produce an electrical signal, called the electromyogram (emg), which can be sensed directly from the surface of the skin. Several experimental prostheses have been developed previously, which use emg signals for control purposes. The major shortcoming of most of these devices has been the lack of graded control of their behavior.

A system has been developed which utilizes surface emg signals from the biceps and triceps of an amputee's arm to provide graded control of an elbow prosthesis. The development included as an intermediate step the control of a simulated forearm in a digital computer, in real time. In its present form the signal processing consists of full-wave rectification and lowpass filtering of the emg signals from biceps and triceps muscles; an actual mechanical elbow prosthesis can now be voluntarily controlled through the subject's emg signals.

The performance of the system in its present form is described, and its indications for future work are outlined. Foremost among these is the need for feedback to the patient of (at least) position information from the prosthesis, outside of the visual sense. One method by which it may be possible to accomplish this in an inherently normal manner is suggested.

The use of nerve signals as the control signal for a prosthesis offers many potential advantages over the use of the emg signal; the practical problems involved in observing nerve signals, however, combined with the lack of information as to how to properly interpret them, makes this approach infeasible now. Preliminary experiments aimed at deriving the necessary information in order that nerve signals can ultimately be used are described here. The results are still inconclusive.

## TABLE OF CONTENTS

I.	INTRODUCTION	1
II.	AMPUTEES AND PROSTHESES: THE PROBLEM	3
	2.1 General Background	3
	2.2 Standard Means of Prosthesis Control	4
	2.3 Cineplasty	7
	2.4 External Power	7
	2.5 Bioelectric Control	9
III.	PHYSIOLOGY	13
	3.1 Nerve	13
	3.2 Muscle	16
	3.3 Muscle Spindles	18
	3.4 Organization of the Neuromuscular System	18
	3.5 Conscious Control and Sensation	21
IV.	INVESTIGATION OF NERVE SIGNALS	23
	4.1 Reasons for our Interest	25
	4.2 Other Recordings of Gross Nerve Potentials	28
	4.3 Our Attempts to Measure Nerve Signals	29
	4.4 Conclusions on the Nerve Experiments	35
V.	USE OF MUSCLE SIGNALS FOR PROSTHESIS CONTROL	37
	5.1 Factors Affecting Use of Muscle Signals	37
	5.2 Data on EMG Signals	39
	5.3 Proposed EMG-Controlled Prosthetic System	45
VI.	DEVELOPMENT OF THE PROSTHETIC SYSTEM	47
	6.1 Simulation of the Proposed System	47
	6.2 The Prosthetic Arm	57
	6.3 EMG-Controlled Prosthetic System	59
VII.	EVALUATION OF THE SYSTEM - SUGGESTIONS FOR THE FUTURE	65
	7.1 Over-all System Performance	65
	7.2 Mechanical Portion of the System	68
	7.3 EMG Signal Processing	69
	7.4 Feedback to the Amputee	71

## CONTENTS

APPENDIX I Equipment Used in Attempts to Record Gross  
Nerve Potentials

APPENDIX II Method Used for Measuring Power Spectra of  
Bioelectric Signals

Acknowledgment

Bibliography

## I. INTRODUCTION

For many years, the standard means of control of the action of a prosthesis has been through gross body motions of the amputee. In the early 1950's the late Norbert Wiener observed that the biological signals that controlled actions which had been lost in amputation, were still present in the body of the amputee. Professor Wiener suggested that certain of these signals could be used to control a prosthesis, instead of using gross body motions. The main advantage of such an approach is that its mode of control would be similar to the control of the corresponding body section that had been amputated. Thus one could logically expect that the amputee's ability to control the device would exceed his ability to control a conventional prosthesis.

Interest in Professor Wiener's idea grew slowly in this country. In Britain and the Soviet Union, however, at least two groups of workers began work in the field. By 1955, the British had reported some progress,<sup>12</sup> and the Russians reported their first accomplishments in 1959.<sup>24,90</sup> The Russian work received a great deal of publicity and, in 1961, on a visit to Russia, Dr. M. Glimcher witnessed a demonstration of the prosthesis that had been developed.

Upon Dr. Glimcher's return, he approached Professor Wiener, who suggested that Professor Amar G. Bose, of the Department of Electrical Engineering at M.I.T., might be willing to undertake a research project in this direction. This author expressed interest in the idea, and it was agreed that the work would be undertaken under Professor Bose's guidance, as this author's Doctor of Science thesis research. Financial support was obtained from the Liberty Mutual Insurance Company, whose interest stemmed from their long-time involvement at the forefront of rehabilitation of the disabled.

In this research effort we continually emphasized a fundamental approach to the problem. The work began in February 1962, and included from the outset one year of study in physiology, prosthetics, and related fields. As a result of this work, we undertook to carry out two investigations simultaneously. Through the study of the relevant physiology it became clear that the use of nerve signals for control purposes could potentially offer considerably improved rehabilitation, as compared with that possible through the use of muscle signals. Thus, despite the practical difficulties involved in the study and use of nerve signals, we elected to investigate the various factors affecting their application to prosthesis control. Some preliminary data on nerve signals have been obtained.

It is clear, however, that for use in the immediate future, the electromyographic signal (emg) is the most practical bioelectric signal for control purposes. Thus we set out to study, in parallel with the investigation of nerve signals, the properties of the muscle signal. This began with an investigation of the spectral characteristics of the emg signal, as a function of muscle tension. The study of physiology, combined with the experiences of others in prosthetics, have led us to emphasize that the control

behavior in the prosthesis should be similar to that in a normal arm. Our interest in this ideal of normal behavior caused us to choose a very flexible form of signal processor, the digital computer, for our experimental emg-controlled prosthesis. Although it was clear that the ultimate control system must be small and compact, and therefore simple, we chose to place as few restrictions as possible on the initial form of the system. In this way the fundamental issues relating to the control problem could most easily be identified and studied.

## II. AMPUTEES AND PROSTHESES: THE PROBLEM

### 2.1 GENERAL BACKGROUND

Mechanical devices have been devised for many years to assist persons who have, through various medical disorders or accidents, or congenitally, been deprived of some measure of normal physical ability.<sup>49,87</sup> There are examples of such prostheses dating from medieval times. For surgical amputation of an arm or leg, prostheses have taken many forms, and all have had certain deficiencies, for which scientists have not yet found completely satisfactory solutions. Generally speaking, the shortcomings of the arm prostheses that are now clinically available are the following.

1. The prostheses have far fewer degrees of freedom than the normal arm for which they are intended to substitute. Thus they perform certain tasks in an awkward manner, and in some cases only with great difficulty for the amputee.
2. The controls (i.e., the actions of the amputee which control motions of the prosthesis) for a given prosthesis motion are not related to the actions of a normal person which cause the corresponding motion of a normal arm. For example, flexion of the "elbow" of a prosthesis may result only from movement of the shoulder of the amputee; whereas in a normal person elbow and shoulder motions can be independent. The result of this is that the amputee must learn an entirely new pattern of activity in order to make the prosthesis useful to him, and his ultimate performance is often limited because the degree of relearning which is required is so great, and the constraints of the control system are so severe.
3. The only sensation that the amputee receives from the prosthesis is that which he can obtain from visual observation of its performance, and from any extraneous noises that it makes or forces that it transmits back through the socket and harness. We will see that this is significantly less sensory information than is present in a real arm. The degree of visual concentration which is required to properly operate present prostheses precludes development of more complex, more flexible devices because the patient could not adequately control a device more complex than one of the current types. Furthermore, it is now very difficult for an amputee to carry on a conversation or engage in any other activity that reduces his conscious concentration on the prosthesis, while simultaneously operating his prosthesis; while for a normal person a large number of common activities involving his arm can be carried on while he is talking and performing other activities perfectly naturally, and with very little concentration on or attention to his arm motions.

Although recent concerted efforts in prosthesis design have been historically related to the World Wars, the number of civilian amputees now far exceeds the number of amputees resulting from war injuries. A recent estimate places the number of civilian amputees at approximately one-half million, while the veteran amputees of all wars number approximately 40,000.<sup>50</sup> Nevertheless, it was immediately following



World War II, through the efforts of the National Research Council in this country, and simultaneously in other countries, that scientific research was channelled into this field. By comparison of the engineering sophistication of many of the machines that have been developed by modern science with that of current prostheses, one cannot avoid feeling that the area of prosthesis development has been largely ignored. It is clear that a concerted effort cannot fail to provide significant improvement in the capabilities of the prostheses available for amputees. It is probably for these reasons that the present broad effort on the over-all problems of the amputee has developed.

Arm amputees vary over a wide range in many ways. For example, amputation may be due to injuries leaving stumps in various stages of injury themselves. Amputations may be due to diseases leaving the muscles and nerves in the stump and the surrounding area of the person in various stages of damage. An amputation may be congenital, and the existing stump in such a case may not closely resemble that of a normal person. The strength and psychological state of amputees vary widely, depending on age, cause of amputation, and so forth. A patient may have other injuries or disabilities that constrain the way in which he may be fitted. Finally, an upper-extremity amputation may be at any of at least six functionally different levels, as shown in Fig. 1, from a wrist disarticulation, in which case normal wrist rotation is usually retained, to a removal of the whole arm and shoulder (interscapulothoracic) in which case no arm or shoulder function exists at all. The breadth of these variations of course, only increases the difficulty of building one or a few types of devices to fit all cases; the individual cases will often impose constraints on the type of prosthesis which can be fitted, which may preclude the application of any "standard" device.

## 2.2 STANDARD MEANS OF PROSTHESIS CONTROL

An important evaluation with respect to any amputee is the number of possible sites which he can provide for control of the prosthesis. By this is meant the number of motions or actions which he can control, and which either are of no present use to him because of his amputation or are less important than some of the actions that have been lost in the amputation and can be restored by a prosthesis. The intention is to retrain the patient to use these actions to control other actions in the prosthesis. The three most common control motions for an above-elbow prosthesis, for example, are flexion and extension of the shoulder, and the shoulder shrug.<sup>135</sup> The concept of using motions to control a given activity of the prosthesis which are not associated with such activities in a normal person has been accepted for many years, largely because very little choice was possible. In most cases the amputation leaves so little of the normal activity which it is desired to restore that there is no possibility of prosthesis control by the remainder.

Generally speaking, the longer the stump, the greater the number of possible control sites, and the smaller the number needed, because of the relatively lesser degree of disability in these cases. Thus the extremely short stumps are the ones that are

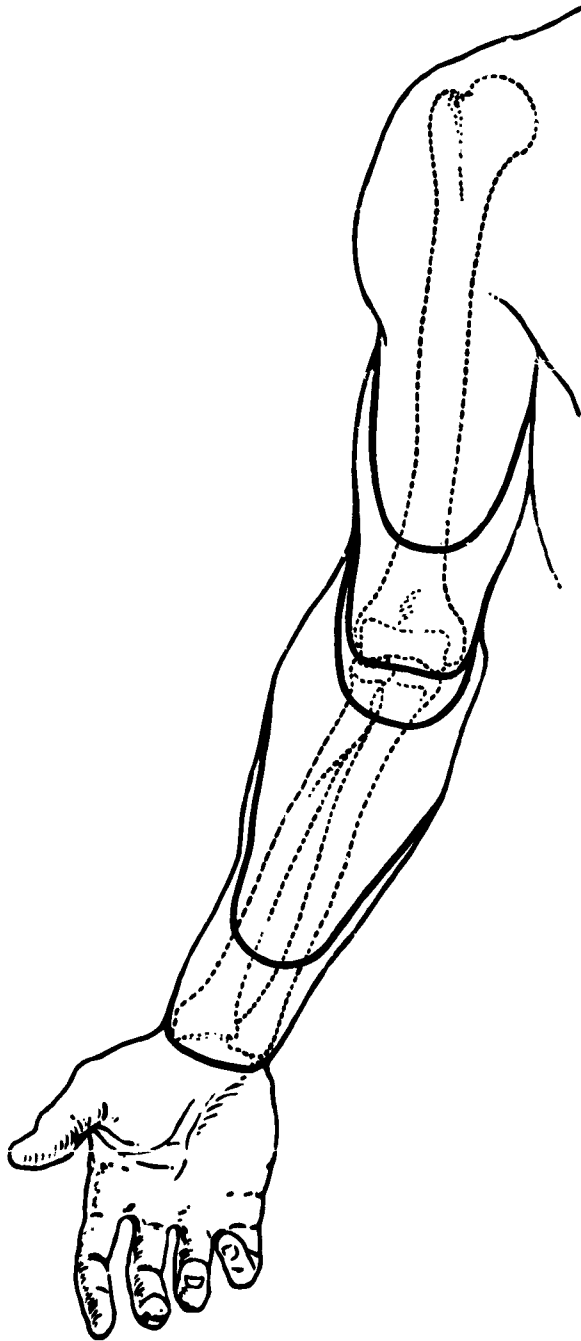

From Human Limbs and Their Substitutes by P. E. Klopsteg and P. D. Wilson. Copyright ©1954 McGraw-Hill Book Company, Inc. Reproduced by permission of McGraw-Hill Book Company.

Fig. 1. Major sites of amputation in the upper extremity.

most discouraging, since the patient needs a great amount of help and has the least residual function with which he can be helped.

The types of controls which are most common consist of a cable anchored to some point on the harness which is supporting the prosthesis, connected at its other end to

the segment of the prosthesis which it is desired to move. The point on the harness which is used is carefully chosen so that by some motion that the amputee is able to perform he can exert tension on the cable. At most, three such motions have been successfully used in one above-elbow prosthesis, as shown in Fig. 2. Considering the number of degrees of freedom in the human arm this is very little indeed. We must remember, however, that the restoration of even one degree of freedom to an amputee is considered by him to be a considerable improvement, especially if the choice of action to be restored and action to be used in controlling it are carefully tailored to the patient's needs. On the other hand, it seems apparent that any effort to find improved ways of providing this assistance, which may make possible far greater help for the handicapped, is justified.

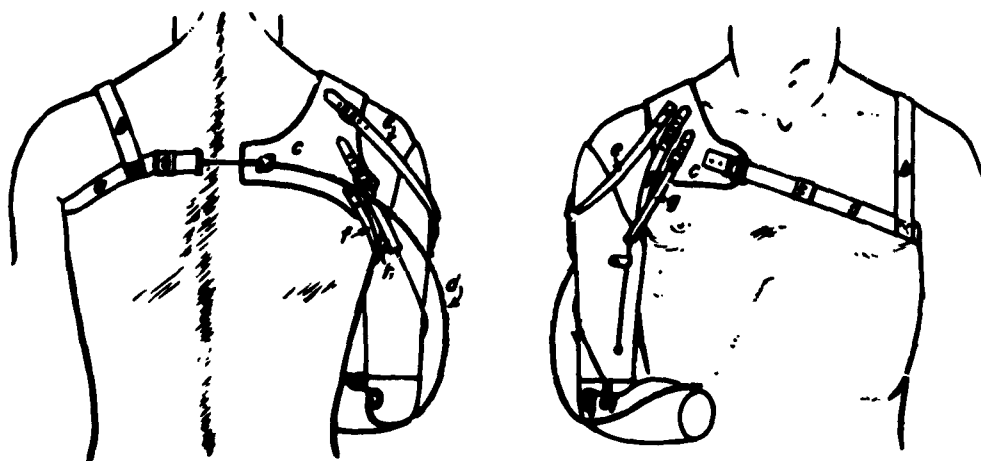

Above-elbow triple control with shoulder saddle. Chest strap *a* buckles near front apron of shoulder saddle *c* and passes around opposite axilla to give rise to shrug-control cable *d*. Strap *b* gives vertical suspension to *c*. Straps *e* and *f* are suspensors passing through D rings on the lateral and medial aspects of the socket. Arm-extension control *g* runs from shoulder saddle to elbow lock. Arm-flexion control *h* passes around socket and attaches to forearm lever *i*.

From Human Limbs and Their Substitutes by P. E. Klopsteg and P. D. Wilson. Copyright © 1954 McGraw-Hill Book Company, Inc. Reproduced by permission of McGraw-Hill Book Company.

Fig. 2. Triple-control harness for an above-elbow amputee.

Besides the problem of using a very few control sites to control a device that should have a rather large number of degrees of freedom, one other factor plays an important part in prosthesis design. That is, that the control site must have available enough force to deliver to the prosthesis, and it must be able to impart to the control cable sufficient excursion to operate the prosthesis motion for which it is intended. Of course, by appropriate lever arrangements force can be traded for excursion, but the product of the two, force times excursion, must be sufficient for the required prosthesis action. This requirement has led to the abandonment of a great number of otherwise satisfactory control sites.

When an actual gross body motion is used to control a prosthesis, this motion is coupled to the prosthesis so that in addition to its normal action as before, that motion also controls the desired action of the prosthesis. Thus the amputee is in the position of having to perform some unrelated body motion in order to control the prosthesis. The external effect of this is undesirable. It has long been considered an important goal to control a prosthesis directly from the force of some muscle, rather than through the motion of some part of the body. If this were possible, any muscle which could be flexed would be a potential control site. The same technique could possibly be applied to the muscles in the stump which formerly moved a portion of the body which was amputated, and if these muscles were then connected to control the corresponding prosthesis action, then the resulting over-all effect could logically be expected to be more natural for the amputee than any other possible means of control of that action.

### 2.3 CINEPLASTY

A technique was developed which could make these goals attainable. It is called cineplasty, and dates in its earliest forms from before World War I. It consists of surgically modifying a muscle by creating a skin-lined "tunnel" through it, through which a pin can be inserted, which in turn can operate a control cable to a prosthesis.<sup>86</sup> Cineplastic tunnels have been made in biceps and/or triceps, in the pectoral, and with less success in the forearm flexor and extensor groups. They have been most successful in the biceps in the case of below-elbow amputations, in which case the normal insertion of the biceps into the stump of the forearm is released, leaving to other muscles the job of flexing the elbow, and the biceps "muscle motor" is used to control closing of the terminal device. Because of harnessing problems, however, cineplasty has not been as successful as one might hope in using muscles to control the prosthesis motion corresponding to the real motion those muscles formerly controlled.

Despite its potential, the cineplastic technique has fallen into disuse in recent years, at least in the United States. The cineplastic tunnels have been found to be very difficult to keep clean, and are a frequent source of irritations and infections. Furthermore, they involve a surgical modification to the body which amputees and their families have found difficult to accept. Hence cineplastic operations, which were at one time quite prevalent in this country, are now virtually unknown.

### 2.4 EXTERNAL POWER

Another important concept has been the application of external power, controlled by a very small motion at some control site, for operation of the prosthesis.<sup>112</sup> For example, the bulge of a muscle as it tenses would be a possible control site if it were able to impart to the prosthesis sufficient force and excursion for prosthesis operation. By connecting such a control site to operate an electrical switch, which in turn operates an electrically powered prosthesis, or to operate a mechanical valve which in turn applies pressurized carbon dioxide to a gas-powered prosthesis, as examples, it would be possible to relax considerably the restrictions on the choice of acceptable control sites.<sup>53,85,105,149</sup>

The results of the various research efforts in the application of external power to prosthetics has shown that such techniques are feasible in many cases, from the point of view of the equipment weight and volume considerations. It is possible to provide the power mechanisms, and the necessary power supply sources, in packages with the capacity for a normal day's activity, at least for upper-extremity prostheses.

It has become clear, however, that new developments are needed in the way in which amputees must control their prostheses. The interface between the man and his prosthesis must be made less abrupt. The equipment must in its mode of control take account of the limitations and needs of the amputee. The concept of sequential control, by using a very few control sites for control of a large number of motions, does not meet these requirements. Thus the application of external power alone does not provide the most satisfactory prostheses. Indeed, by making possible the movement of several more joints than would be possible with conventional prostheses, it challenges the imagination of the researcher with the problem that the amputee is actually less able to control the "improved" device than he would be to control a conventional prosthesis.

One reaction to this result has been an aversion to "complexity" in prostheses. This was well-founded in the day of the "IBM arm", which was admittedly very complex, both in construction and in control. But it is a contention of this author that complexity in and of itself is completely irrelevant to the amputee; rather it is the complexity of the control operations which the amputee must perform, for motions which may in fact be very simple, which matters. One of the assumptions that is basic to the work reported here is that, although complexity in the prosthesis itself ought to be avoided when possible for many good reasons (such as cost and trouble-free performance), one of those reasons is not the fear that the amputee will reject the prosthesis. Complexity from the point of view of the control required to operate the prosthesis, however, should definitely be avoided.

## 2.5 BIOELECTRIC CONTROL

It has been shown that many amputees are potentially capable of learning wholly new patterns of activity in order to control a prosthesis whose mode of control is very different from that of a real arm. For example, the present standard prostheses all require such a readjustment, and there are many patients who operate them remarkably well indeed. It is admittedly difficult to find a fair basis for comparing the performance of a normal arm with that of a prosthesis, and it is probable that at least in the details of the motions considered, the real arm will always be superior. It is another contention of this author that a prosthesis design that requires a minimal adjustment by the patient to the control mode of the prosthesis is preferable to one requiring considerable adjustment, for the reasons that (1) a large proportion of patients will not be completely successful in learning a wholly new mode of control, and (2) even the patient who is best adjusted to his prosthesis will still be limited in his performance by the limitations of the control system, and by the limits of his ability to produce all of the various control

signals necessary. Thus we propose that, if such an ideal were attainable, the proper method of controlling an artificial arm would be to control it in an identical manner to that in which a real arm is controlled, specifically the real arm that was just amputated. This would, if it were possible, provide a measure of precision and coordination which may never be attainable by other means.

The ideal manner in which such a scheme might be implemented would be to electrically sense human nerve or brain signals, which were intended by the brain to operate a muscle or a joint which was no longer operative because of the amputation. This signal could then be used to control the corresponding action in the prosthesis. This means any motion, however complex, which had been learned by the patient before his amputation, would again be possible for him after his amputation. A related possibility is that electrical stimuli might be applied to the person, which could give him the same sensations (touch, feel, proprioception) that he formerly had in his real arm.

As we shall see, there are many different ways in which this broad suggestion can be interpreted. Early in the 1950's, Norbert Wiener suggested the use of an electrical signal generated by muscles when they contract, called the "electromyogram" (abbreviated emg). For practical reasons, most of the effort toward applying bioelectric control to externally powered prostheses has utilized the emg for the control signal. This signal can be sensed by very simple means; for example, almost any type of electrode taped to the surface of the skin will suffice for observation of the emg. In 1955, Battye, Nightingale, and Whillis<sup>12</sup> described an experimental prosthetic device using emg as the control signal. This was a prosthetic hook, potentially suitable for a forearm amputee, and used surface electrodes to sense the emg signal. The forearm flexor and extensor groups of muscles, which are normally flexors and extensors of the fingers and wrist, generated the signals which controlled the prosthesis. This device had the capability only of being open or closed under control of the emg signal. No control of force, velocity or any intermediate positions was possible. Those authors did discuss several different possible procedures that might yield a graded control, which would be more satisfactory for the amputee. They suggested either a position or a velocity control servo, and discussed some of the advantages and disadvantages of both types. They do not appear to have considered the normal relations between muscle activity and the emg signals; nor did they emphasize the restoration of an action to the amputee in such a way that his control of it was similar to the control of the normal arm he had lost.

Around 1956, a similar prosthesis was developed in Russia, by Kobrinsky et al.<sup>24,90-93</sup> Details have been lacking for many years, but the best available information indicates that the earliest version was quite similar in its capabilities to the British prosthesis.<sup>54</sup> The Russians have continued to develop their device, however, and the latest version of which this author is aware operates as follows: The emg signals (from a pair of opposing muscles or muscle groups) are processed in such a way that the prosthetic hand either closes or opens at one constant velocity, or stays in

any intermediate position. Thus the amputee can control the position of his terminal device, but he still cannot control its velocity; and only through spurious mechanical slack in the mechanism is he able to control the force that the device is exerting.<sup>140</sup> Nevertheless, this device has apparently found wide acceptance in the Soviet Union; it is understood that at least 200 are in use. This version is known to have been licensed to both British and Canadian groups.

A recent development has been announced by Bottomley and Cowell.<sup>22</sup> In their case, a prosthetic hand or hook is controlled by emg; amplitude information in the emg signal is used, and the amputee is able to control both velocity and force. This device is a significant step in the direction of providing normal behavior for the emg-controlled prosthetic terminal device. It uses both a force and a velocity feedback loop, and the amplitude of the processed emg signal is made proportional to velocity while the hand is open, that is, while the force that it is exerting is negligible. When the hand encounters resistance, however, while it is closing on some object, the force feedback loop dominates the behavior, and the force with which the object is clasped is then proportional to the amplitude of the processed emg signal. The latest information available to this author is that this device has not yet been widely used; reactions of amputees to its behavior would be interesting and valuable.

It has been the purpose of the research described in this report to study the problems associated with providing for amputees graded control of prostheses, by using voluntarily generated bioelectric signals as the control source and an external supply of power to operate the prosthesis. In order to create an experimental situation that could be studied without the severe mechanical constraints inherent in the lower extremity, we decided to focus our attention initially on arm rather than leg prostheses. Considering the foregoing summary of the work in related areas which has preceded our effort, it is considered of prime importance that the behavior of a normal arm be our model, and that every effort be made to duplicate the control aspects of a normal arm in the prosthesis. It will be seen that feedback from sensory organs in a normal arm contributes significantly to control of the arm, and certain aspects of the control of the prosthesis are limited by the lack of feedback (other than visual) to the amputee. The topic of feedback will be discussed further, although time has not allowed us to devote significant attention to this area.

### III. PHYSIOLOGY

Our basic problem, of utilizing bioelectric signals for prosthesis control, led directly to a need for information about the various signals involved in the body in the control of muscle action. Our emphasis on the concept of restoring normal control to an amputee, to whatever extent possible, raised questions about the normal neuromuscular control in the body. By a study of physiology, the various signals present in the system, and their interactions, could be identified, and those most interesting for bioelectric control in an amputee could be studied further. We shall now summarize the information available on the organization of the neuromuscular system, and the details of the important components in that system. This information bears both directly and indirectly on the remainder of the work discussed in this report.

#### 3.1 NERVE

All of the activities of life, including both voluntary and involuntary activities, involve in their performance a multiplicity of devices in the body, called nerves.<sup>52,150</sup> This includes thinking, receiving any sensation, such as touch, smell, vision, and performing any motion. The brain itself is, for the most part, a collection of nerves. In the sense in which the term is being used here, a nerve consists of a cell body, an axon, and, depending on the type and function of the nerve, it may also include dendrites or some nerve ending appropriate to the function of the nerve. In this sense, the term "nerve" is synonymous with neuron.

The cell body of a nerve is the source of nourishment for the nerve; a section of a nerve which is separated from the cell body degenerates rapidly. The axon, often referred to as the nerve fiber, conducts a nerve impulse in either direction, although for any given nerve axon only one direction of transmission is used by the body. For a neuron in the brain, spinal cord, or a motor nerve in some peripheral area of the body, there are dendrites serving to receive nerve impulses from other neurons. Depending on the state of a given neuron, which of the other neurons that connect to its dendrites are actually transmitting nerve impulses, and in what sequence, a nerve impulse may be initiated in the given neuron to travel down its axon. For a sensory nerve, there are specialized nerve endings such as Pacinian corpuscles, Golgi tendon organs, and many others, which serve to measure the variable appropriate to the type of nerve, and cause the axon to transmit a signal to the central nervous system which will be interpreted as the proper sensation.

In the peripheral nervous system, which is the portion of the nervous system outside of the brain and spinal cord, the term nerve has another meaning: In this area of the body, many nerve axons communicate between muscles and sensory endings and the spinal cord, and the paths along which they do so each contain thousands of such axons. The group of nerve fibers which travel a common path, collectively are also referred to as a nerve. Thus the radial nerve in man, for example, is one of the main nerves in the



erm, and contains both sensory and motor nerve fibers. A sensory nerve fiber is one that conducts impulses from some sensory ending toward the central nervous system, and is also referred to as an afferent fiber. Motor fibers, which conduct signals from the central nervous system to some muscle, are often referred to as efferent fibers.

Little is known about the details of the action of any of the parts of the nerve, with the single exception of the axon. The axon of the squid has been extensively studied because it is large and has therefore been susceptible to physiological techniques that cannot be applied to the neural elements found in the human body, since they are much smaller.<sup>69-73</sup> There appears to be a great deal of similarity between the types of components found in human and other mammalian nervous systems.

The nerve axon, in the "resting" state (in the absence of a nerve impulse), has a potential of approximately -90 mv as measured from the inside of the axon membrane (+) to the exterior liquid (-). This potential is maintained by an ion transport mechanism for which models exist but which is not thoroughly understood. During the transmission of a nerve impulse, the nerve membrane is depolarized in one region at a time, this depolarization being propagated from one point on the axon to the adjacent one by the ion currents resulting from the depolarization at the first point. At the peak of the depolarization curve, the potential of the axon reaches approximately +30 mv, measured as before. Just after a nerve impulse has passed a given point on a nerve axon, there is a period during which that region of the nerve membrane is less sensitive to stimulation than before. This interval is referred to as the refractory period. A sketch of the potential of a nerve impulse being propagated along a nerve axon is shown in Fig. 3.

The point at which a nerve ends on the dendrites or the cell body of another nerve is called a synapse. There appear to be both excitatory and inhibitory types of such connections, the former being those at which the impinging of a nerve impulse is likely to cause the generation of another such impulse in the axon of the succeeding nerve, and the latter being synapses at which the appearance of a nerve impulse will tend to inhibit the generation of such a second impulse. The stimulus is thought to be transmitted across the synapse by an electrical depolarization of the membrane of the succeeding nerve. Details of the action of many aspects of nerve activity are not well understood because experimental techniques are still not capable of the required precision, small size, and so forth.

Nerve fibers in mammals range in diameter from as small as 0.3 micron (1 micron =  $10^{-6}$  meters) to as large as 22 microns. Roughly speaking, the larger the fiber diameter, the faster the conduction rate. Nerve conduction rates range from less than 1 meter to more than 100 meters per second. Conducting rates of nerve fibers fall in certain groups; depending on the nerve trunk considered as many as 4 or 5 of these groups can be identified, and they are labelled, in order of decreasing conduction rate, alpha, beta, gamma, . . . .

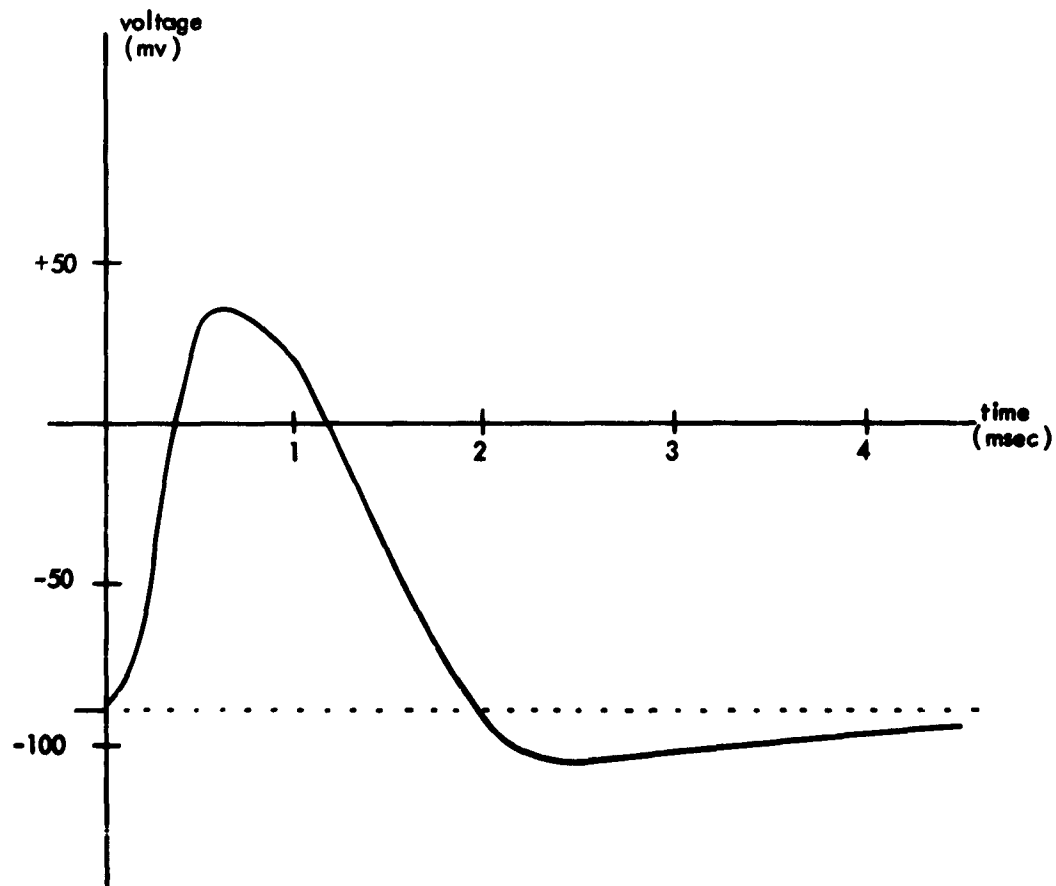

Fig. 3. Electrical nerve impulse measured between an intracellular electrode (+) and an extracellular electrode (-). Resting potential approximately -90 mv. (After Hodgkin and Huxley.<sup>73</sup>)

### 3.2 MUSCLE

There are two major classes of muscle in mammals: skeletal and cardiac (smooth muscle).<sup>151</sup> Skeletal muscle is responsible for all voluntary movements, and concerns us most in this work. Cardiac muscle is to a greater extent involuntarily controlled; examples are the heart and other visceral bodies.

A skeletal muscle consists of thousands of thin filaments, called muscle fibers. A muscle is usually innervated by a branch of one nerve, consisting of several hundred motor nerve axons, and some sensory nerve fibers. Each muscle fiber is innervated once by one of the motor nerve axons, which also innervates other muscle fibers. A set of muscle fibers innervated by any one nerve fiber is called a motor unit. Although perhaps not all muscle fibers in a motor unit contract each time a nerve impulse is received along the nerve fiber that innervates them, it is understood that only when an impulse is received along that nerve fiber will the muscle fiber contract.

The connection between a motor nerve fiber and a muscle fiber is called a motor end plate. The means of transmission of the nerve stimulus to the muscle fiber at the end plate is fairly well established to be by chemical means. The muscle-fiber membrane is depolarized by the appearance of the nerve impulse and, by means which are probably similar to propagation of a nerve impulse, this depolarization is propagated throughout the muscle fiber. The result is an electrical impulse somewhat similar in shape to that of a nerve axon, but longer in terms of spike duration than in the case of a nerve. The conduction rate is of the same order of magnitude as that of the motor nerves that innervate the muscle, being about 5 meters per second in mammalian muscle. Beginning during the electrical impulse, however, and continuing for a considerable time afterwards, the muscle fiber produces also a mechanical twitch of tension. When the fiber is held at a fixed length during the twitch (an isometric contraction), the relations among the arriving nerve impulse, the muscle electrical response and the mechanical twitch are shown qualitatively in Fig. 4.

Electrically, a muscle exhibits a refractory period similar to that of nerve. This refractory period probably plays little part in the usual function of muscle, since the "logic" functions of nerve do not appear to exist in muscle. Mechanically, however, muscle twitches can superimpose and add to a maximum tension that considerably exceeds maximal twitch tension. This is referred to as tetanus; there is evidence that a stimulus rate of 50 per second or more is often required before the twitches fuse completely and the maximal tetanus tension is attained.<sup>151</sup>

In any voluntary contraction, the familiar uniformity of tension is attained by exciting many motor units in a muscle in a "random" pattern, in such a way that the total tension over the whole muscle is approximately the same at any instant. The macroscopic effect is then the smooth muscular activity with which we are familiar. For a motor unit whose average excitation frequency is less than that which results in complete tetanus, the average tension which it is contributing to the total muscle tens

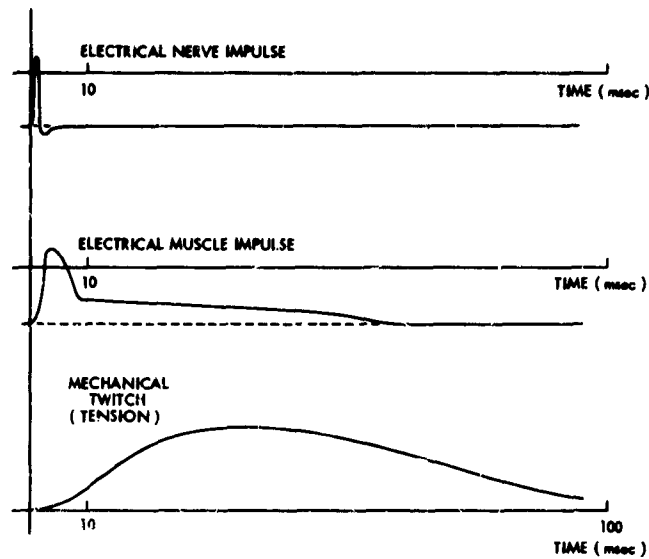

Fig. 4. Comparison of the nerve impulse, the electrical muscle impulse, and the mechanical muscle twitch. Qualitative relations only are shown for isometric conditions. (After Woodbury and Ruch.<sup>151</sup>)

can be varied by varying its excitation rate. Another way in which the total muscle tension can be varied is by varying the number of motor units which are active in the contraction.

There is evidence that both of these methods of gradation of muscle activity are used in the body. At low tensions, there are apparently only a few motor units active, and the over-all muscle force is varied by varying the discharge frequencies of these few motor units. At high degrees of tension, however, other motor units are recruited, and apparently their discharge frequency is not varied as widely as was that of the motor units active at low tensions. Rather, gradation of tension at high levels is obtained largely by varying the number of active motor units.<sup>18</sup>

It is interesting to note here that, in voluntary contractions, excitation rates to given motor units sufficient to cause complete tetanus are not always observed; maximum rates that have been observed are in the range 35-40 pulses per second, whereas complete tetanus often requires a rate as high as 50-60 pulses per second. Hence it is probably only in maximal efforts that any significant number of motor units are stimulated tetanically.<sup>141</sup>

When any muscle fiber is stimulated, the depolarization of its membrane produces an electric field whose potential appears across any pair of electrodes in the vicinity. The combined effects of the fields of all muscle fibers in a muscle, as observed with a pair of electrodes neither of which is inside a muscle fiber, is the electromyogram (emg). Whereas the electrical membrane potential is fairly well defined, the emg signal seen in any voluntary contraction is the interaction of the potentials created by a great many muscle fibers, all being excited in some random manner. Thus the emg

does not have well-defined characteristics; the geometry of the relations among the various muscle fibers and the electrodes, and the electrical properties of the tissue surrounding the muscle, are so complex that it is impractical to attempt to formulate the field equations in order to predict the emg signal. Even if this were possible, the statistics of the distribution of stimuli to the various motor units of a muscle are not known.

### 3.3 MUSCLE SPINDLES

There is a small number of devices distributed within the muscle which are not active in producing tension, but are sensory in nature.<sup>52,57,120</sup> These are called muscle spindles. The central portion of a muscle spindle (called the nuclear bag) is elastic and can be stretched but cannot actively contract. Connecting to either end of the nuclear bag are two contractile poles, consisting of a few small muscle fibers (called intrafusal fibers). The nuclear bag is innervated by a large fast-conducting sensory nerve fiber. The intrafusal fibers are innervated by small, slow-conducting motor nerve fibers (gamma efferents).

Because of the relative ease with which they can be found and worked with (relative to other sensory devices), the muscle spindles are probably the best understood of sensory structures. The sensory nerve apparently transmits nerve impulses at a rate that is logarithmically related to the length of the nuclear bag. Thus the muscle spindle contributes to a position sense. The spindles seem to exhibit only slight adaptation and this only after a period of several minutes.<sup>120</sup>

Spindles stretch parallel to the primary muscle fibers in the muscle, connecting the tendons or bones in much the same way as the remainder of the muscle does. There are two ways in which the nuclear bag can be stretched: (1) by lengthening the muscle which then would lengthen the nuclear bag accordingly, and (2) by excitation of the intrafusal fibers by the gamma efferent nerve fibers, in which case even if the over-all muscle length remains constant, the nuclear bag will be forced to lengthen.

### 3.4 ORGANIZATION OF THE NEUROMUSCULAR SYSTEM

The well-known knee-jerk response to a tap on the tendon just below the kneecap is an example of the action of a reflex arc which is a very common type of connection in the neuromuscular system. Studies of the reflex arc have contributed vastly to our understanding of the mechanism that provides proprioceptive control of joint position.<sup>43,62,63,77,100-102</sup> The ability to hold a joint in some constant position without conscious attention to its position (and with only very small movements about that position) is likely to be the main function of the reflex arc, and certainly is a main function of the muscle spindle. The muscle spindle is the prime component in the postural position control system.

The gray matter of the spinal cord is sketched in section in Fig. 5. Motor neurons are located in the ventral horn, and travel down the peripheral nerve from there to th

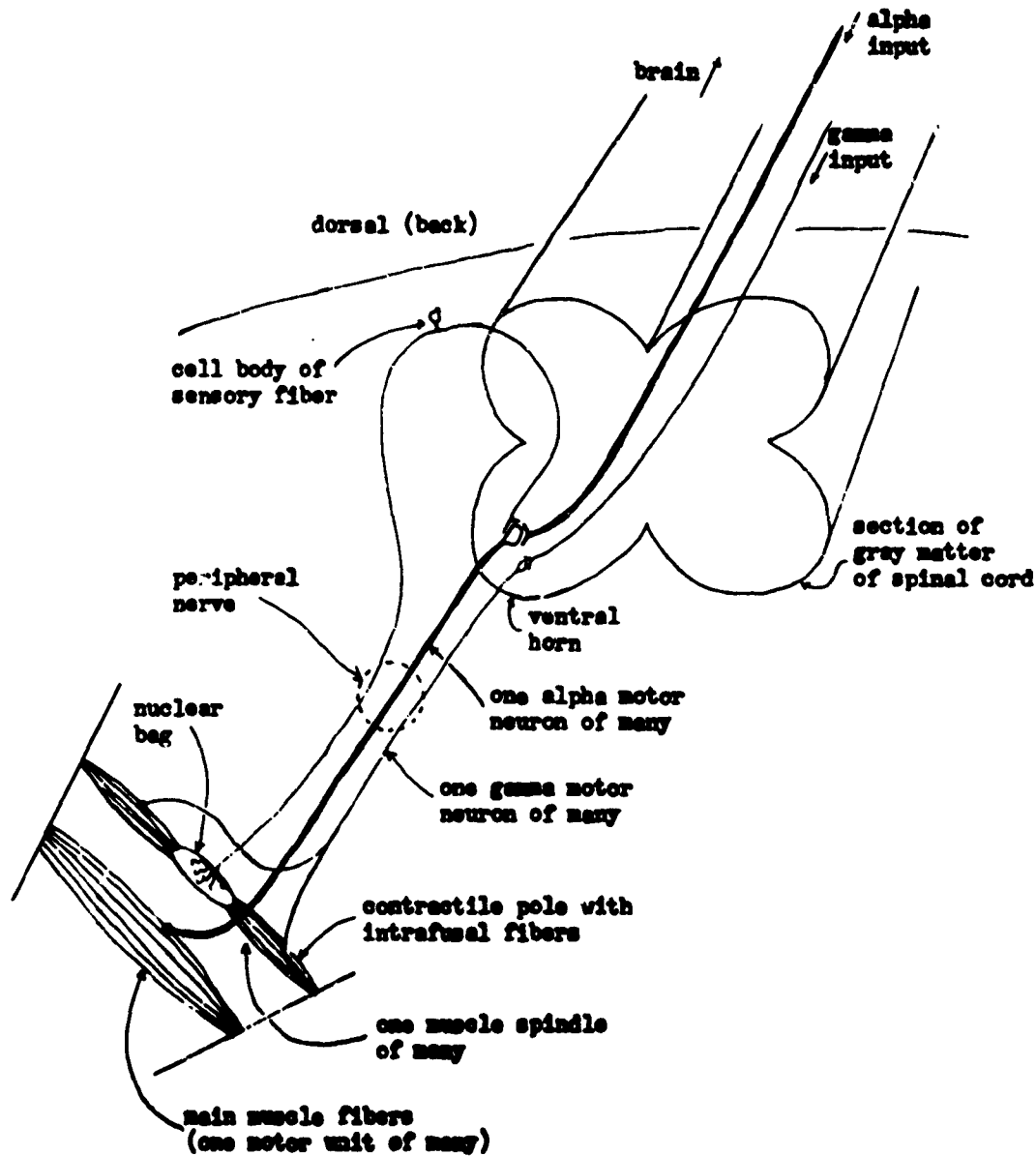

Fig. 5. Section of the spinal cord in man, and the important peripheral pathways.

muscle. Sensory fibers enter the spinal cord by the dorsal root, their cell bodies being located in the dorsal-root ganglion. The sensory fibers that concern us most at this time are those innervating the nuclear bags of the muscle spindles of a given muscle. There is considerable weight of evidence to indicate that these spindle signals, upon entering the spinal cord, directly form excitatory synapses with the alpha motor neurons for the muscles from which they came.

The effect of such a connection can be understood as follows: Assume that the muscles and nervous system are in some stationary stable state, and that some external

influence forces some small change upon this situation, such as the tap on the tendon, which momentarily stretches some muscle. Then the spindles in that muscle will sense an increase in muscle length, and return an increased nerve impulse rate along their respective sensory nerve fibers. This signal will then in turn cause the average impulse rate along the alpha motor nerve fibers of the muscle which was just stretched to increase. The result will be an increase in the tension in that muscle, causing the joint in question to move in a direction so as to shorten the muscle, tending to reduce the spindle discharge rate, and thereby returning the system to its former state. At the same time, there is evidence that the alpha motor neurons for the antagonist muscles are forced to decrease their average discharge rate, although this may not be due to a direct connection from the spindles. This will decrease the tension in those muscles, tending once again to assist in returning the joint to its former position. The position feedback control loop so formed is diagrammed schematically in Fig. 6.

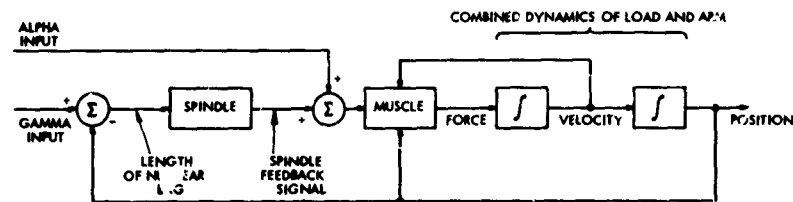

Fig. 6. Reflex control loop

Of course the description above is grossly oversimplified in several ways. In the first place, there are rarely only two muscles, an agonist and an antagonist, for a given joint. Second, there are several muscle spindles in each muscle, and many alpha motor nerve fibers. Nevertheless, the action of the reflex arc seems to be consistent with the oversimplified description given.

The "control loop" shown in Fig. 6 contains two inputs. The one that is understood to be relevant in the postural type of performance just outlined is the gamma input. This corresponds to a signal applied to the gamma motor fibers from the central nervous system, and it can be seen that this corresponds to a different "set point" of desired position for the joint. Thus the postural control system can be used with a different input signal to regulate position at any point.

The second input to the neuromuscular control loop shown in Fig. 6 is labelled the "alpha input," and is intended to represent a direct input from higher centers in the brain to the muscle, by which a rapid action can be caused, without the relatively long time delays that are involved in the gamma system. It is thought by most researchers that this alpha input is the signal used for rapid voluntary motions.

From the way in which the gamma input and muscle spindle are interconnected, however, it is clear that the gamma-nerve signals could be used as voluntary command signals for slow movements from some initial position to some final one. Whether or

not the gamma signals are so used is not universally agreed upon. Many apparently believe that the gamma input is activated for postural control only. If this were so, then at least near the termination of some voluntary motion the spindles would be activated (through the gamma system) to provide a reference point for the steady position that should follow the motion, but during the motion the spindles should have no effect. Some unpublished experiments by Stark and Rushworth seem to support this theory.<sup>132</sup> Nevertheless, Granit, Merton, and others appear to believe that the gamma system is used for all slow carefully controlled motions.<sup>42,44,58,59,109</sup> It has been pointed out by Hunt that the gamma and alpha systems appear to receive simultaneous stimuli.<sup>79</sup> His interpretation is that this serves to keep the spindle operating in a sensitive portion of its characteristic. Merton suggests that this is exactly the type of behavior to be expected if the gamma system is actually being used for servo operation during the voluntary motion.<sup>109</sup>

There is one other type of sensory organ associated with muscular activity which has been identified specifically. That is the Golgi tendon organ, which is located in the muscle tendons where it measures muscle tension. It has been found that the Golgi tendon organ has a high threshold, thereby producing only small signals until the muscle tension reaches high levels. There is a clinical observation tending to correlate with these data on high threshold of the Golgi tendon organ, called the "clasp-knife" reflex.<sup>120</sup> In extraordinary feats of exertion of muscles, it is not an unusual experience that the muscles should suddenly "give," temporarily losing their capability to provide the forces expected of them. This action is similar to that of a clasp knife, in which a great deal of force is required to begin the motion of closing the knife, after which the knife suddenly "snaps" closed. This and other data indicate that the Golgi tendon organ acts as an inhibitor of the alpha motor neurons, at high muscle tensions; its function is thought to be mainly that of a "safety valve," serving to release the tension in the muscles when this tension reaches such a high level that damage to the muscle could result.

### 3.5 CONSCIOUS CONTROL AND SENSATION

A voluntary motion exists in the conscious thought in terms of a functional rather than a specific description. That is, the act of grasping some object is thought of in just those terms, and a general idea of the shape and perhaps weight of the object, along with its position in space relative to the person is the type of information which exists on a conscious level. "Lower" in the brain, however, the concept of grasping is translated to a preprogrammed sequence of individual muscle motions, based on the person's experience since birth in grasping objects, which will enable the grasping action to come close enough to the object that local feedback can complete it. Clearly, this translation occurs between the conscious level and the level of the lower motor neurons, since they are specialized to the specific muscles they control. It is understood that some major portion of this "coding" is performed in the cerebellum, an area of the brain which apparently is an important link in the coordination of muscle activities.<sup>42,44,58</sup>



In any case, at the level in the spinal cord where the specific motor signals leave the cord and travel down the proper peripheral nerve to the muscle, the motor neurons for the correct muscles are activated in the proper sequence. The signals are carried along the nerves to the muscles, and they begin to contract in the required manner. This operation may or may not involve regulation by the spindles. As the hand contacts the object, the sense of touch relays this information back to the spinal cord, and to higher levels, and the closing of the hand is coordinated.

Many other senses are involved in activities related to muscle actions. Certainly the visual sense is one of the most active, being not only the source of the idea that initiates many actions (i.e., the sight of an object might suggest reaching for it), but also furnishing continuous feedback of position information with which the remainder of the motion can be optimized. There are joint position receptors in joints, whose function it is to report joint position to the central nervous system, so that we may "feel" position without visual observation. Certainly, the sense of touch is involved in grasping and other actions. The ability to feel shape, temperature, and pressure, is due to the existence of specialized receptors in skin for sensing these variables, and for various types of muscle activities all of these sensory signals play a part.

It is of interest to consider what sense we have on a conscious level, that is, what sensory information existing in the body is in such a form that the person can be consciously aware of it. Certainly, it is true that we can feel the positions of many joints in the body, at least for short times. For example, with one's eyes closed it is possible to bring the forearm to some specified angle with the upper arm, to a surprising degree of accuracy. It is apparently the opinion of many researchers that the spindle signals, which could provide this information, do not reach a conscious level. We conclude that the conscious feel of joint position is probably due to the joint receptors alone.

This author and several others had the occasion to perform a very crude experiment which, if repeated in a well-controlled manner, would cast doubt on the conclusion that conscious sensation of joint position is due only to the joint receptors. We were fortunate to have the opportunity to examine an amputee whose amputation was very long, but still slightly above the elbow. That is, he had no part of the lower arm or the elbow joint remaining, but otherwise his upper arm was complete. We asked him to attempt to show us, by positioning his other (normal) arm, in what position he felt as if his amputated arm was at each instant. We then commenced to move his biceps and triceps muscles by external pressures through the skin, including pushing in a direction on the skin opposite to that in which the underlying muscle was being pushed. It is unfortunate that we were ill-prepared for this experiment, for we were not able to anesthetize the skin in order to be absolutely certain that no skin sensation was confusing our conclusions. In every case when the biceps was displaced upwards, and the triceps was moved in the opposite direction, he claimed to "feel" that the missing arm was being raised. This applied for small and large displacements and in all cases of

various attempts to mask any skin sensation by forcing the skin in different directions. This also applied when the triceps was left slack, and only the biceps was moved. Furthermore, he had remarkable sensation not only of direction, but of magnitude, for he could follow displacements varying from very small to very large, and he demonstrated that his sensation was as if the missing forearm had moved through the complete range of positions. Finally, we were able to have him feel that his missing forearm was being supported in one position for a period in excess of 60 seconds, with no observable adaptation, which tends to eliminate the skin as a source of the position sense which he demonstrated.

As a result of the experiment described above, we suggest that (1) either there are other position sensors in the body, not in the skin, whose signals are transmitted to a conscious level, which have not been found, or (2) the muscle-spindle signals do reach a conscious level. In order to be absolutely certain of these conclusions, the experiment should be repeated on several other subjects, and with better controls than we had. It is certain in this case, however, that the conscious sensation of position of his missing arm was not derived from information transmitted by the joint receptors, since these were not present in the subject.

It is questionable whether any direct feedback of force (or weight) information from sensory organs to a conscious level exists. Consider, for example, the usual method used to compare the weights of two objects: One "hefts" them, then "catches" them. Thus the response in any position sensor could be the source of the signal which is measured. Consider also the fact that when one attempts to apply a constant tension to a spring balance, without looking at the balance, a rapid, wide drift in the force applied will be observed.

On the other hand, one still has some conscious "feel" of the force that he is applying against an infinite load, for example. And it is very easy to distinguish two very different weights. It is possible that this sensation of force is only an indirect one, derived from a knowledge of the conscious effort being applied to support the weight. Another possibility is that the pressure sensors in the skin, which are assumed to adapt very rapidly, are maintained in an active state by small motions of the hand which is applying the force, thereby yielding a continuing measurement of the force that is applied. This would then apply most clearly when a significant surface area of the person's skin was in continuing contact with the object against which the force was being applied.

There are a great many details about the coordination of motions with the responses of the many different sensory receptors in man, which are unknown. Thus we find ourselves potentially limited by our lack of knowledge, in our desire to restore lost function in a normal way to an amputee. On the other hand, it should be reasonably clear from our discussions that many aspects of the control and coordination of a normal arm are not provided by present prostheses. It is reasonable to say that present prostheses can provide the mechanical capabilities for the more important actions, but the lack

of sensory information of any sort other than visual, seen against the background of the richness of sensory feedback in the normal, is a handicap which severely limits the ability of an amputee to take full advantage of the mechanical capabilities of the prosthesis.

Thus we see that the most important efforts required in the development of superior prostheses are: to provide normal control of the prosthesis in the "motor" direction, in order that the training required of the patient be minimized, and attempt to provide at least the elements of sensory feedback, again in a way that is as close as possible to that observed in a normal arm.

## IV. INVESTIGATION OF NERVE SIGNALS

### 4.1 REASONS FOR OUR INTEREST

Although it was anticipated at the beginning of our research that the emg signal would be the most practical biological signal for prosthesis control initially, we resolved to study other possibilities in order to assess their advantages and disadvantages, and to determine the magnitude of the practical problems involved in using other signal sources. Our intent was to derive the information that will be needed in the future, when the use of signals other than emg for control purposes may become feasible. For these and other reasons, we undertook the basic study of physiology described in Section III, and one of the concepts suggested by that work was the theoretical possibility of utilizing signals derived from peripheral nerves for prosthesis control. The organization of the neuromuscular system and the central nervous system are such that all of the neural control and sensory information transmitted between the central nervous system and all portions of an arm is transmitted along nerve fibers contained in the very few nerve trunks in the arm. As a result, the most straightforward approach to the use of bioelectric signals for prosthesis control, from the point of view of the theoretical availability of all of the requisite signals and control paths, consists of connecting to the central nervous system at the point where the arm previously did; that is, of connecting to the main nerves in the arm.

More specifically, some of the potential advantages are the following.

1. By connecting to the amputee at the level of the ends of his remaining nerves (if such a connection were possible on a practical level), we inherently use all that remains in his body for its normal purpose; we restore function in a way that cannot interfere with the normal action of what remains in his body.

2. At least in principle, we have available exactly the same nervous channels for prosthesis use as previously communicated with the portion of the arm which was amputated. Thus, theoretically, there should be no limits on our ability to provide as many degrees of freedom in the prosthesis as were lost in the amputation.

3. There appear to be no limits on our ability to provide this restoration of function in a way that will seem perfectly normal to the amputee, since it is theoretically possible to use the nervous channels that exist for their normal actions.

4. It is in principle possible to provide sensory inputs to the amputee, again in a way by which the sensation that he receives should resemble normal sensation.

Of course, in the comments above practical considerations are ignored. It should be clear from the discussion in Sec. III that the means of "coding" a signal in the central nervous system, which we have so glibly referred to, is not simple. In fact, there are in any nerve trunk in the human arm thousands of nerve fibers, including motor fibers, proprioceptive sensory fibers, and other sensory fibers, in a distribution which, to this author's knowledge, has never been investigated fully. Certainly, the motor fibers

relate to from 20 to as many as 50 or so muscles in the arm, the number depending the level of the amputation. The sensory fibers, however, formerly branched to all areas of the skin, in addition to the muscles, and there are perhaps 6 or more different types of fibers, if we classify them according to the type of sensation which they previously carried. Furthermore, there is a series of experiments tending to indicate that, even if the sensory fibers were used to send the same signal as each previously did before amputation, there may be some complex coding necessary to properly identify these signals to the central nervous system. That is, the sensation received may not only be a function of the nerve fiber along which it is received, but also a function of specific type of nerve ending which produced it, or the tissue in which that ending is imbedded, coded in a way that is completely unknown at present.<sup>111</sup> Thus there is a great number of questions which must be answered before use of specific nerve-fiber signals for prosthesis control can be attempted.

There is at least one other problem associated with any attempt to use the various individual nerve-fiber signals for control purposes. It is not now possible, even in experimental environments, to specify any one nerve fiber, identify it, and place an electrode in it. All microelectrode studies of single-fiber potentials in intact nerve trunks, of cats or any other animal (including humans), to the knowledge of this author have simply involved placing the electrode in any fiber, without any a priori knowledge of that fiber's identity, and perhaps moving the electrode from there to some other initially unidentified fiber. Furthermore, by using any of the various techniques that have been found useful in studying single-fiber potentials in multiple-fiber preparations, it has rarely been possible to keep the electrode in the same fiber for a period in excess of several hours. Finally, even if it were possible to sense single-fiber potentials, the extremely large number of such signals makes it quite unlikely that a system could be constructed to make use of the data so obtained. Only if we accept the principle of retraining the patient to an unnatural mode of control, might a small number of individual fiber potentials suffice for control purposes. Basmajian<sup>11</sup> has reported some initial success in training patients to voluntarily control individual muscle motor units, and hence individual nerve fibers. We feel that the main advantages to the potential use of nerve signals for prosthesis control are lost when the approach requires the degree of training of the patient which would be necessary in order for a patient to voluntarily control individual nerve fibers.

There is an overwhelming list of serious problems and limitations to any attempt to use individual nerve-fiber signals for prosthesis control, of which those discussed above are only a few. Thus we have no difficulty in concluding that such a system is not possible now, nor will it be possible for many years.

There is another level at which the idea of using voluntarily generated nerve signals can be interpreted. Although it is impossible at this time to use the signals travelling along individual nerve fibers for control purposes, it may be possible, at least in the foreseeable future, to place electrodes on nerve trunks as a whole, and to

use signals that may be obtained by this technique. Failing this, it may be possible to spatially separate from each other the nerve fibers that serve different functions (the group of motor fibers which control one muscle might be grouped together), and place gross electrodes on each of these groups of nerve fibers. A partial separation of this type may even be found to exist in the body, at some level of the nerve. The important questions relevant to such an approach are, What signals can be obtained by this technique?, and, How can these signals be interpreted in order that they may be used for control purposes?

In one very real sense, of course, the problem of using nerve signals is compounded, not simplified, by the restriction that the electrodes be placed only on the nerve trunks as a whole. For, although the identity of the signals seen at the nerve-fiber level was unclear, the confusion of the thousands of nerve-fiber signals which will be observed at the level of the nerve trunk (if any are observed at all) may be overwhelming.

The possibility that some means of control may be attainable by this technique rests on a few important observations.

1. With a few exceptions only, the majority of the motor fibers destined for any given muscle travel down some one nerve trunk.
2. The muscles are composed of many motor units, and there is one motor nerve fiber for each. Because smooth motions are performed by a statistical distribution of excitations throughout the muscle, it is not necessary to identify precisely which motor unit (and hence which nerve fiber) is being excited, but only to determine from the signals received the average number of motor units which are active in each muscle and their average rates of excitation.
3. Most normal motions are performed through contributions from many muscles. This applies even to the simplest of motions, of which perhaps elbow flexion is one. Motion of the elbow joint, independently of motion of any other joint in the body, may involve as many as 6 muscles or more.<sup>60</sup> Hence it may be possible to use gross information derived from the nerves to identify which action is being performed, through the distribution of the over-all activity to the various nerve trunks or the groups of nerve fibers.

Many of the limitations on electrode techniques, mentioned above, apply in this case also. To the knowledge of this author, there are no reports of attempts to place gross electrodes on nerve trunks, and leave them in place for extended periods, without injury to the wearer, deterioration of the signal received, or movement of the electrodes.

On the other hand, during recent years there has been considerable publicity of the success in implanting "pacemakers," with a pair of electrodes, in and near the heart. There has been a great deal of research on suitable materials for implanting in the body. There are several implantable transmitters in existence, in various stages of research and testing, with many types of electrodes and other transducers for many body parameters.<sup>89,95,130</sup> Hence it seems reasonable to expect that if there were some purpose to such a project, an implantable nerve-trunk signal transmitter could be

developed rather quickly. The physical constraints on such an instrument do not seem to be considerably different from the constraints placed on devices that have been reported, at least experimentally. The major difference between the requirements on a nerve-signal transmitter and those on transmitters which have already been developed seems to be that the signal under consideration is one derived from a gross nerve trunk, and that the electrodes must in some way be designed for this type of duty.

Hence we undertook as a separate part of this research to study signals derived from gross-nerve trunks, the various electrode configurations which were possible among those which were best, and any other questions that might arise related to our ultimate desire to utilize those signals, if possible, for prosthesis control. This work was undertaken with the full knowledge that in all probability it would not turn out to be feasible for a great many years, but the potential advantages of such an approach were so attractive that we considered our effort, and any others which could be stimulated, justified.

#### 4.2 OTHER RECORDINGS OF GROSS NERVE POTENTIALS

There have been many studies of the transmission of nerve signals in nerve trunks in which the initial signal was produced by a gross electrical stimulus at some point on the nerve.<sup>27,118</sup> Such works led to the classifications of nerves according to their conduction velocities, and eventually to the correlation of conduction velocities with fiber diameters. The fact that gross signals could be recorded by this method is not relevant to our work, because the stimuli were such that all fibers that were active at all were transmitting a signal which began in synchronism with that in all of the other fibers. In a certain sense, such an experiment is not measuring a normal system because the transmission measured is in one of two directions, and for whatever direction is studied either the motor or the sensory fibers are transmitting in their normal direction (orthodromic), but the other set of fibers is transmitting in a direction that is never used by the body under normal conditions (antidromic).

Various experiments have been performed in which sensory stimuli were applied peripherally, and gross responses at various points in the central nervous system have been noted. A common experience is that at some intermediate point, say, at the level of some peripheral nerve, no gross signal can be observed, yet electrodes placed in the proper area of the cortex are able to provide signals, which are synchronized with the stimuli to such an extent as to leave no doubt about their identity.<sup>55</sup> Such findings have two valuable lessons for our work.

1. It may not be possible to record a signal from a gross nerve bundle even when that bundle is transmitting a signal that has some meaning.
2. The answer to the question of whether the desired signal is available may depend on the stimulus that generated the signal in the first place.

Voluntary signals inherently have no precise time identification corresponding to those resulting from external stimulation. Hence the expected signal in the case of a

voluntary action is a "random" discharge, some average properties of which would be related to the activity that is being performed. In simple terms, we are looking for information about the signal transmitted by the brain, which may look different from that which appears at the same point in response to some artificial stimulus.

In animals, it is possible to study voluntary signals, but the only way in which these signals may be controlled and synchronized is by some stimulus. In order that the response of the animal be reasonably considered to be voluntary, the stimulus must be an indirect one; that is, the stimulus must make no direct connection to the system being studied. One way of meeting this criterion is to condition the animal by training him to respond in the desired way to some simple stimulus such as the sound of a buzzer. Some issue can still be made as to whether a signal elicited in this way is really the result of a voluntary motion, even in this case. We must also consider the details of our assumptions about the source of the signals that we hope to observe. It is reasonable to expect that gross signals of the type that we wish to investigate, if they are observed at all, are the result of some advantageous synchronization of the potentials in a large number of nerve fibers. Since such synchronization appears to exist under some conditions and not under others,<sup>55</sup> it is likely that the presence of the signals that we wish to study will depend on the specific features of the action that is being performed, and the specific nerve trunk that is being observed, as related to the particular anatomy of that species. Finally, we wish to study the responses obtained from a single subject as he performs various actions, and as he performs one action many times, with small, controlled variations. This requires a degree of control of the animal which is very difficult to achieve. As a result of these considerations, we concluded that the results obtained for animals would not necessarily carry over to humans, because of the unique nature of the information of interest to us in the data. Since our aim is to evaluate these data from the point of view of their potential value in the future for prosthesis control, it is necessary that our data relate to the human.

#### 4.3 OUR ATTEMPTS TO MEASURE NERVE SIGNALS

There are several surgical procedures on humans in the course of which one or more nerve trunks in the arm are exposed. In amputees, operations occasionally are performed in which the nerve trunks are to be severed. In these cases, it may be possible to place electrodes on the various nerve trunks and attempt to record signals from them.

We were fortunate to have the opportunity to be present in five such operations, the details of which will be described subsequently. In all, we attempted three basically different electrode configurations, in at least one of which significant electrical signals of definitely biological origin were recorded. It is not certain, however, that any of the signals recorded was generated by the nerve fibers themselves. The details of our attempts to trace these signals will be elaborated below.



In the first of the operations, the patient was a unilateral forearm amputee, in whose stump the several main nerve trunks had attempted to regrow, with the result that painful neuromae had developed. The pain was localized near the end of the stump but except for sensation, the whole portion of each of the nerves below the elbow joint was of no value to the patient, and in the surgery it was planned to sever all of the nerve trunks sharply at or near the elbow. A section of each of the nerve trunks was to be removed to ensure no further attempts at regrowth. The portion of the surgery preceding the recording of nerve potentials was to be done under local anesthesia only, in order to ensure that the patient would be awake and able to attempt to perform the motions in (amputated) arm as instructed.

The first electrode configuration attempted consisted of wrapping the outside of each of the nerve trunks with a pair of thin wires, and using these wires as the electrodes. This technique yielded a signal that was quite low in amplitude when the patient was instructed to relax, and increased significantly in any nerve trunk when the patient was asked to perform some action involving muscles controlled by that nerve. Typical actions were "make a fist," "spread fingers apart," "extend fingers," and so on. The signals appeared on the three nerve trunks studied (ulnar, median, and radial) in approximately the proper patterns for the actions being performed, under the assurance of the usual anatomy of innervation of the various muscles by the nerves.

The equipment used to record the potentials in this operation is described in Appendix I. A sample of the signal observed on the ulnar nerve, during the command "fan fingers apart," is shown in Fig. 7. For comparison, a sample of the signal observed during the command "relax" is also shown. It is clear that there is significant signal present, corresponding to the effort being made by the patient. By placing emg needles in the proper muscles, it was easily verified (when it was not obvious by visual observation of the forearm) that strong muscle activity was present, showing that indeed the signals were being transmitted down the nerve to the muscle, as expected. (Recall that the amputee had no fingers to fan apart; he was trying to perform the necessary action both from memory and by knowing the corresponding actions on his other hand, which was normal.)

The power spectra for the signals shown in Fig. 7 are shown in Fig. 8. The procedure used to prepare these data is described in Appendix II. It is again clear from this form of the data that there is significant signal present when the patient is asked to perform the activity, which is absent otherwise.

On the other hand, the details of the signal do not resemble those that we were expecting from a summation of nerve activity. Referring to the nerve impulse sketch in Fig. 3, we see a pulse width of 1-2 msec at most, while the activity observed with our electrode configuration shows slow waves, of width  $\approx$  2-15 msec. The "fast spike" activity anticipated from nerve fibers seems to be attenuated very much more than expected. In fact, the observed signal resembles the emg signal generated by muscles, often observed clinically. A sample of emg signal, recorded with a pair of needle electrodes placed in the flexor carpi ulnaris muscle, and its spectrum, is shown for

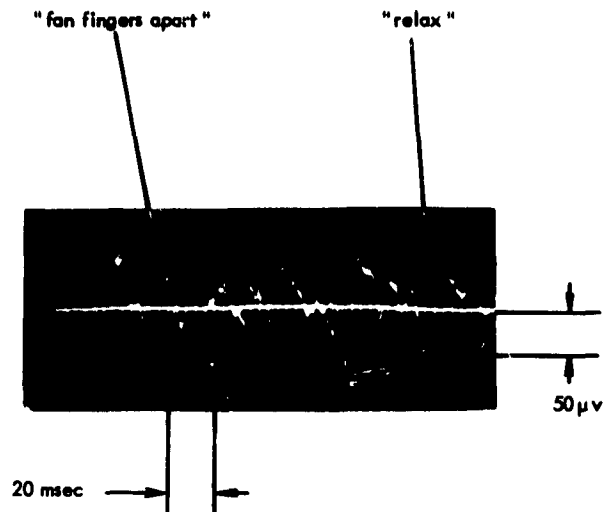

Fig. 7.  
Samples of signals recorded  
at ulnar nerve.

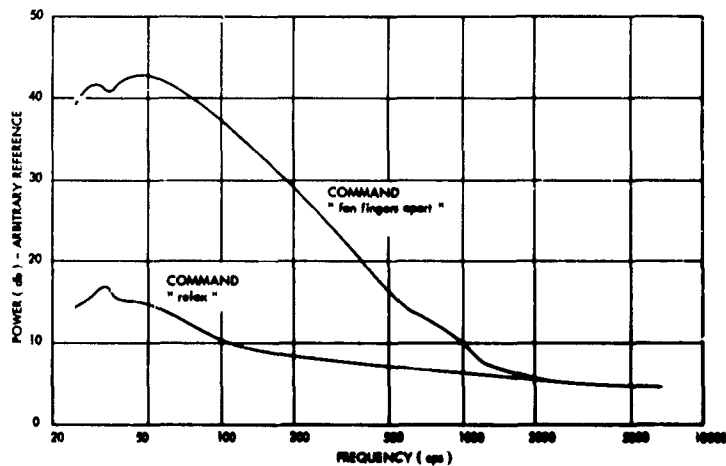

Fig. 8.  
Power spectra of signals  
recorded at ulnar nerve.

comparison purposes in Figs. 9 and 10. The nerve and emg signals are not identical, of course, as can be seen by comparing Figs. 7 and 9, or the power spectra in Figs. 8 and 10. It is clear, however, that the frequencies containing most of the power are approximately the same for the two signals; and there is not as much power at high frequencies in Fig. 8 as one might have expected.

Because of the large volume of muscle in the vicinity of the nerve with which we were working, we anticipated that the emg signal might appear on our records if no precautions were taken, and so our experimental procedure was designed as follows: The sections of nerve on which the electrodes were placed were approximately

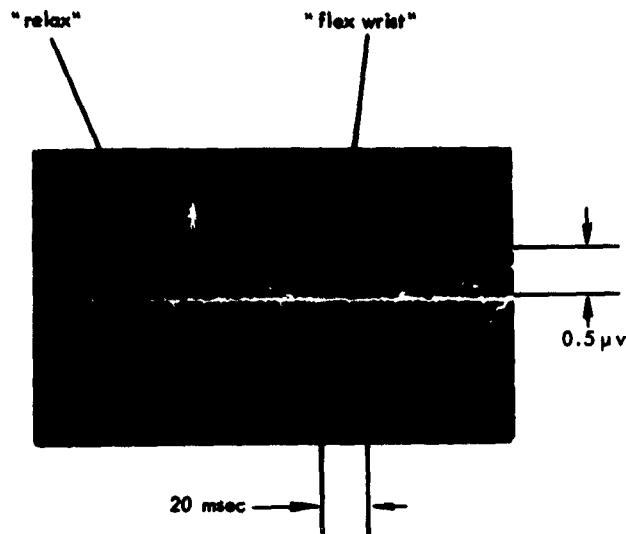

Fig. 9.  
Sample of needle emg recording  
from flexor carpi ulnaris.

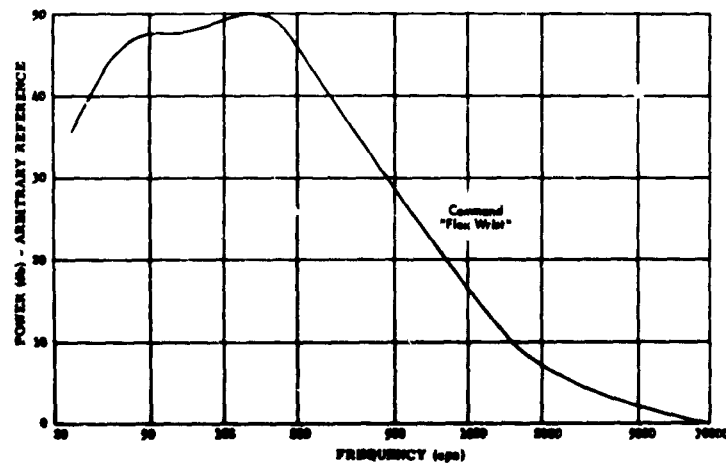

Fig. 10.  
Power spectrum for needle  
emg recording of Fig. 9.

2-3 in. long, and were separated from the other tissue, including muscle, by a rubber sheet, placed between the nerve and the remainder of the arm. The nerve was, however, kept wet with saline solution, in order to preserve it. It was our initial intention that the rubber sheet would effectively insulate the nerve from the remainder of the tissue, so that the signal observed could only come from the nerve itself. In retrospect, however, we suspected that the saline (a good electrical conductor), held in the rubber sheet against the nerve, may have allowed the nerve trunk to act as an electrical conductor, and to pass the emg signal observed at one or the other end of the nerve segment to the recording electrodes.

During this same operation, two variations of the electrode configuration were attempted: In the first, one of the electrodes on a given nerve was wrapped around the nerve bundle as before, while the second electrode only touched the outside of the nerve trunk at one point. In the second variation, again one of the electrodes was wrapped around the nerve trunk as before, but the second electrode was placed inside the nerve bundle from one cut end of the nerve. (The portion of the nerve in which the electrode was placed was then removed by sectioning the nerve proximal to the electrode locations.) Neither of these two electrode techniques was satisfactory, no clear signals being observed.

The following three operations at which we were able to attempt to record nerve data were "ulnar transplants." In these cases, a segment of the ulnar nerve near the elbow (the "funny bone") had been irritated by the groove in the bone along which it passed. The surgical correction consists of "transplanting" the ulnar nerve at this point over to the inside of the elbow, where it can pass undisturbed. Two patients were involved in these three operations, one on both arms. All three arms were normal, and it should be observed that in this type of operation, the nerves are intact and are intended to remain that way; hence certain of the experiments attempted with the first patient were not possible in these cases.

Our electrodes in these later operations were stainless-steel wires, 0.050 inch in diameter, assembled in pairs into pieces of cork, so that the electrodes were spaced approximately 3/4 inch apart. The cork served to hold the pairs together, and was placed 3 inches from the ends of the electrodes. The ends were hooked so that they could support the nerve trunk; such a construction was found to operate as well as the wrapped wires did in the first operation. Our technique consisted of exposing the nerve trunks through approximately 3 inches of their length, lifting them out of the surrounding tissue, and supporting them each with a pair of electrode hooks, in turn supported by a length of thread. The electrode pairs were located approximately in the center of the exposed segments of their respective nerves, and the nerves were lifted so that the center of this section, where the electrodes were, was approximately 1 inch from the nearest other tissue. The nerve trunk was not otherwise supported, and rather than being soaked in saline, it was only gently wiped occasionally with a saline-soaked blotter. The first of this series of three operations, our second of all, duplicated the significant results obtained in the first operation.

We desired to prove conclusively whether the signals that we had recorded in the first two operations were actually generated by the transmission of nerve impulses or were spurious signals such as emg from some nearby muscle. For the last three operations we evolved the following procedure: We planned to record the signal observed from the ulnar nerve on one channel of a tape recorder, the emg from the abductor digiti quinti muscle (chosen because it is very far distal from the recording site and innervated by the ulnar nerve) on a second channel, and emg from any muscle near the nerve electrodes on a third channel. After verifying that the expected signals

were observed, we planned to inject curare into all of the muscles in the immediate vicinity of the nerve segment that was being studied. Curare acts to temporarily block neuromuscular transmission at the motor end plates. By observing the emg in all of the surrounding muscles, we intended to check if indeed those muscles no longer were active. If our hypothesis was correct that the signals we had been observing at the nerve were generated directly by the nerve fibers, then those signals should remain active as before. And the abductor digiti quinti should also remain active. This would indicate that nerve transmission has not been affected by the curare which had been applied to the muscles near the nerve. There was no reason to believe that the curare should have any effect on nerve operation, and this was borne out in the experiment.

The second step in the plan was to block the nerve transmission, by an injection of xylocaine into the nerve, at some point. In the first of the three operations, this was to be done distally to the recording electrodes, in which case the signal on the nerve electrodes should remain undisturbed if our hypothesis as to their origin was correct. In the two other experiments, the nerve block was attempted proximally to the electrodes first, in which case that portion of the nerve signal which is due to motor nerve fiber impulses would be expected to disappear. In either case, muscle activity in all muscles innervated distally by that nerve should disappear, and any sensation that the patient received from areas of the skin innervated distally by that nerve should also disappear. In the case of the nerve block proximal to the electrodes, any signal still appearing on the nerve electrodes would be expected to be due to sensory fiber signals from areas distal to the recording site. In the case of the nerve block distal to the recording site any signal that disappeared from that previously observed on the nerve electrode would be due to such sensory information.

As a final step, a second nerve block was planned to be made on the other side of the electrode recording site. The final result should be a complete absence of signal on the nerve electrodes.

In two of the three operations of this sequence of experiments the curare was effective in inactivating the muscles in the vicinity of the nerve electrodes, and in these two cases the signal appearing on those electrodes was not perceptively affected. This tends to indicate that the signal is not, as was suspected, caused by conduction of emg signal along the nerve from adjacent active muscles. Such a conclusion is not a firm one, however, until the complete sequence of experiments is successfully accomplished and it is shown that no signal remains; otherwise the possibility that there were other muscles still active through which the nerve passed, and that emg from these was the source of the signal recorded on the nerve electrodes, cannot be excluded.

In no case, however, was any attempt at blocking nerve transmission successful. In no case did the emg signal in the muscle innervated by that nerve completely disappear, although it decreased significantly in all cases. In no case did sensation from areas of the skin innervated by that nerve completely disappear, although this also decreased. Finally, in all cases the signal observed at the nerve electrodes decreased,

but it never disappeared. Thus because these nerve blocks were never completely effective we cannot be certain that the observed signals were actually generated by the nerve fibers directly, since such a conclusion would depend on the assumption that there are no other sources of electrical signals except the nerve fibers and the specific muscles that were inactivated with curare. The conclusive test of whether these signals are actually motor-nerve fiber signals is whether they can be eliminated with a nerve block proximal to the recording site. Until this has been accomplished, we must leave the question of their source open.

#### 4.4 CONCLUSIONS ON THE NERVE EXPERIMENTS

By conducting a large number of experiments calculated to test our equipment and our recording and electrode techniques, we satisfied ourselves that the recorded signals were biological in origin, and were observed at the pair of electrodes claimed. Although we believe that our plan for tracing the origin of the observed signals is valid, experimental difficulties prevented success in carrying out this plan in the three attempts that were made. The most recent suggestion as to the cause of our inability to effect satisfactory nerve blocks is that the xylocaine actually takes as long as an hour to completely diffuse throughout the nerve trunk, and even though certain fibers may be inactivated earlier, it may be necessary to wait this long for the block to become completely effective. If such an experiment is satisfactorily carried out, then the question of whether the signals that we have described actually originate in the motor-nerve fibers themselves, should be answered.

It is our opinion, based on the precautions taken to electrically insulate the nerve from all other possible sources of signal, that the observed signals are generated by motor-nerve fibers. The main argument tending to cast doubt on that statement is that the observed signals seem to be too slow for nerve signals; i.e., that if they were generated by the nerve-fiber action potentials transmitted along the nerve trunk, then they should be dominated by the high frequencies present in the relatively fast activity of a single nerve-fiber action potential. Recall, however, that the nerve fibers are surrounded by a heavy fascia sheath, whose effect on the signals is almost certainly that of a lowpass filter.

Under the assumption that the various nerve fiber potentials are of the same general shape and are short compared with the time constant of the lowpass filter formed by the fascia sheath, within the passband of that filter, we can assume that their spectrum is approximately uniform. In such a case, the spectrum of the signal obtained at the output of the filter carries very little information about the spectrum of the input signal, but reflects only the system function of the filter itself. Translating this back to the nerve potentials under consideration, we realize that the relative frequency content in the signals observed by our technique will not identify the source of those signals, because of the smoothing action of the fascia sheath.

There are observations in different areas of the nervous system which reflect similar behavior. For example, Goldstein and Kiang<sup>55</sup> show data to which we have already referred, in which the stimulus is an auditory noise burst, and the auditory nerve response is a summation of the fast spikes expected. But the cortical response, observed with a gross electrode, contains a long, slow component despite the fact that, by assumption, that signal is the gross effect of many faster action potentials in the nerves in the surrounding area of the cortex. These results are completely consistent with the mathematical model summarized above, if the nerve potentials are assumed to produce an over-all signal whose spectrum is uniform in the frequency band that is being observed. Assuming that the action of the surrounding tissue is that of a low-pass filter, we find that the observation of a low-frequency component at the electrodes is perfectly reasonable. As a result of these considerations, we conclude that the presence of a low-frequency component, and the absence of the high frequencies, are observations perfectly consistent with, rather than contradictory to, the assumption that the observed signal was generated by the asynchronous activity of many nerve fibers.

The work outlined here is an attempt to answer the first of the important questions relative to the application of gross nerve signals to prosthesis control; namely, What signals can be obtained by the use of gross-nerve electrodes? Assuming for the moment that the observed signals were motor nerve signals observed on the nerve trunks, a much more extensive study must be undertaken to determine the specific relations of these signals to the details of the various intended muscle actions. We recall that, generally speaking, the signals did appear in the expected patterns on the three nerves in the one operation where such data were obtained. Such work would probably have to be done on humans, for similar reasons as those that caused us to do so. The development of transmitters suitable for surgically implanting near the nerves of patients, would probably be a prerequisite to such an investigation. The various studies required would of necessity take many years to accomplish. But we suggest that such a possibility is not far-fetched; we feel that any related research should be encouraged in view of the potential advantages to nerve-controlled prostheses.

For the present, however, it is clear that no nerve-controlled prosthesis can be constructed. We proceed in Section V to study the emg signal, and to show that a system using muscle potentials, albeit with limitations more strict than are desirable, can be constructed, and may prove a valuable contribution to the prosthetic art at this time.

## V. USE OF MUSCLE SIGNALS FOR PROSTHESIS CONTROL

### 5.1 FACTORS AFFECTING USE OF MUSCLE SIGNALS

Relative to nerve signals, the emg signal is very simple to observe in the body. In fact, the emg is so dominant an electrical signal in the body that it is often a serious interference source with respect to nerve signal studies because it tends to mask out the nerve signals of interest.<sup>27</sup> The simplest method of observing the emg signal is to place any pair of electrodes on the surface of the skin over a muscle, tape them in place, and look for a signal resembling the output of a noise generator, which increases and decreases in correspondence with the tension in the muscle. The signal may reach an amplitude of a few millivolts rms; the output impedance of the skin and electrodes in these circumstances may be as high as 50K  $\Omega$  to 100K  $\Omega$ .

On the other hand, beyond the casual observation that the emg signal increases and decreases with tension in the muscle, that signal is as difficult to properly interpret as any nerve or other biological signal. Some work by others, and some results obtained by this author, in attempts to "decode" the emg signal will be outlined below.

There is one fundamental drawback to the use of emg signals for prosthesis control. The anatomy of the body is such that if the joint that must be restored through emg control is too far distal from the amputation site, then the muscles that formerly controlled that motion are no longer present. For example, the muscles controlling hand and wrist motions are almost all contained in the forearm and the hand. Thus it would not be possible to use emg control in the normal manner that we have been advocating, to restore wrist and hand motions to an above-elbow amputee; such an amputee could, of course, potentially have emg control of elbow motion in a normal manner. It might be possible to retrain such a patient to use other muscles, not normally associated with hand and wrist actions, as the source of the emg signals for the control of hand and wrist motions. As we have discussed, it is our opinion that the main advantage of the use of emg control is lost by such a procedure. Thus, except where otherwise specified, in the rest of this report we shall always intend emg control to provide control of a corresponding action in the prosthesis to that which the same muscle previously controlled in the normal arm.

There are two ways in which the emg signal can be sensed. In one case a pair of electrodes is placed inside the muscle (although no attempt is made to place either of them inside a muscle fiber; the electrodes are usually much larger than muscle fibers). This can be done either by surgically implanting the electrodes or, more commonly, by inserting a pair of thin wires into the muscle through the skin, by any of various techniques. There are coaxial needle electrode constructions for clinical use, and other specialized needle electrode configurations for research purposes.

There have been several studies aimed at learning more about the distribution of motor units and excitations to various motor units throughout the muscle, in which



various special types of needle electrodes were used. The results of these studies indicate that the fibers of one motor unit are distributed no more widely than a circular cross-section area in the muscle of 5-7 mm diameter, and an area of that size contains fibers from approximately 25 motor units.<sup>34</sup> They also indicate that the signal from given motor unit attenuates very rapidly with distance from the center of the area covered by fibers belonging to that unit; one report states that the signal attenuates one-tenth of its maximum value in a distance of only 0.38 mm.<sup>142</sup> Hence a pair of wire or other small electrodes will be far more sensitive to the signals from the small number of motor units with which it is in close proximity than from the rest of the muscle. The larger the muscle, the poorer the sample of over-all muscle activity that will be obtained by such electrode techniques. Although the distribution of signals to the many motor units in various contractions is not known, the information on gradations of muscle activity suggests that under some circumstances certain motor units would show no activity, while others would be active. Thus we suspect that for certain contractions electrodes placed in the muscle could show little or no signal. This has been verified by Bigland and Lippold,<sup>17</sup> who show that at low muscle tensions, the signal from small needle electrodes agrees fairly well with that from surface electrodes, but the signal obtained from the small electrodes tends to "saturate" at high muscle tensions.

There are other difficulties with needle or wire electrodes. One of the most important ones is the problem of getting the signal through the skin. Whereas it is possible to insert wires through the skin for clinical and experimental purposes, one doubts that without very special precautions it would be possible to leave them there for several years, as would be necessary for the purposes of prosthesis control. The full range of environments to which patients may be exposed have not yet been fully investigated, and the possibilities of infections, deterioration of the electrodes, and so forth, must be evaluated. There is at least one report of an investigation of this issue; its results were quite encouraging, although the scope of the experiments was not extensive.<sup>127</sup> There have been experimental emg transmitters developed which can be implanted in muscles, and can serve to send the emg signal through the skin without the necessity of wires piercing the skin. The potential formation of scar tissue around the electrodes over a long period of time, which could cause the signal to be degraded, has not been fully investigated. Furthermore, the limitations of small electrodes placed within the muscle apply in any case.<sup>89,95</sup>

The second method of observing emg signals is the one already mentioned, which involved the use of surface electrodes only. The two main advantages as compared with the needle electrode techniques are that there is no requirement that wires pierce the skin at any time; and that the ratio of the distance from the electrodes to the furthest motor unit to the distance to the nearest motor unit in the muscle is now not as great as in the case of needle electrodes. Hence it is likely that the signal measured by a pair of fairly large electrodes on the surface of the skin would represent a less biased

average of the whole muscle activity than would the signal derived from small electrodes placed in the muscle.

The potential difficulties associated with surface electrodes have been listed by many. One of the most serious is the movement artefact: that is, the electrical noise generated by small motions of the electrodes relative to the surface of the skin. With all types of surface electrodes available before 1964 which this author has studied or used, the movement artefact was serious enough by itself to suggest abandonment of the use of surface electrodes for our purposes. The usual method of lowering the skin impedance in order to make a better electrical connection has involved slight abrasion of the skin, followed by the application of some special electrode paste. Often, however, the electrode paste would dry out in perhaps as little as 1 hour, rendering the degree of contact between the electrode and the skin to the same state as if no paste had been applied, or worse. The two problems, of movement artefact and drying of the electrode paste, have both been effectively eliminated by one new type of skin electrode, developed only recently.<sup>13</sup> In this electrode an annular ring of adhesive, double-sided, is used to firmly anchor the electrode to the skin. The central portion of the electrode is recessed, and set inside the electrode unit is a silver-silver chloride pellet, which is the electrical contact itself; however, no portion of the electrode touches the skin. The contact between the pellet and the skin is made purely by the electrode paste, which is sealed from the air so that it cannot dry out. The result is an electrode that can be applied in the morning and used all day with insignificant drying of the electrode paste and with negligible movement artefact.

There are a few other factors relating to the use of surface electrodes. For example, the same factor that makes the surface electrodes responsive to signals from a wider area of the muscle makes them also responsive, to some extent, to signals from other muscles. Thus in an area where many muscles are near the site of the electrodes it is possible to receive unwanted signals from adjacent muscles. This in turn makes it rather more difficult to obtain as many independent muscle "channels" as would be desired; more seriously, it may decrease the degree to which the system duplicates the normal behavior, since if this "crosstalk" is a serious problem the patient may again have to resort to specialized training to learn to minimize the signal in the interfering muscles, which would otherwise cause spurious operation of the prosthesis.

Despite the drawbacks, it should be clear that the use of surface electrodes for sensing emg signals, and use of the signals so obtained for prosthesis control, is the only one of the methods that have been discussed which can be considered practical at this time. The relative simplicity of this technique is so inherently appealing that, throughout the remainder of this report, we shall concentrate solely on this approach.

## 5.2 DATA ON EMG SIGNALS

One of the difficulties that concerned us during the early part of this work, before the improved surface electrodes mentioned above were available, was caused by the

varying degree of contact between the surface electrodes and the skin. One method that we investigated which might have been successful in compensating for such electrode difficulties depended on a variation of the distribution of frequencies in emg signals with muscle tension. Specifically, if certain frequency components in the emg signal increased by a different factor than others did as muscle tension increased, then it would be possible to use a comparison of the levels of different frequency components in the emg to determine the muscle tension. This would make it possible for the electrode contact to change, under the assumption that the effect of such a change was to uniformly attenuate all frequencies, and the prosthesis operation could be made independent of this variation. We refer to the desired property of the emg signal spectrum as a "spectrum tilt."

In order to determine if this idea was applicable, and, more generally, in order to determine if there was any information about muscle tension to be gained by observation of the frequency content of the emg signal, it was necessary to obtain data on the relation between the power spectrum of the emg signal and the muscle tension. Emg was obtained from the biceps of one subject, when he was lifting a 5 and a 15 pound load in the hand. The upper arm was vertical, the lower arm horizontal, and surface electrodes were used. The power spectra for one sample of each of the two emg signals are shown in Fig. 11. These data agree well with those of Hayes,<sup>64</sup> and indicate that, in the frequency band where the signal varies significantly with tension, the power spectrum of the emg signal does not change shape significantly as the muscle tension changes, but increases approximately uniformly throughout that frequency band as muscle tension increases. Similar data for a needle electrode study on a different subject are shown in Fig. 12, showing that the same approximately uniform variation of emg spectrum with tension applies at the higher frequencies than are observable in the needle electrode emg signals.

As a result of these data, the possibility of compensating for variations of signal amplitude resulting from varying degrees of contact of the surface electrodes with the skin was ruled out, at least by the method proposed. We resigned ourselves to accepting whatever variations in signal strength were forced upon us by the electrode configuration to be used. We are fortunate that this did not become a serious difficulty, owing to the improved electrodes which became available.

The emg signal, as observed either with surface or needle electrodes, is an "interference pattern," caused by the interference of the signals generated by the many motor units in the muscle. Although each motor unit probably generates a fairly well-defined pattern for that unit, the statistical nature of the excitation times for the many motor units in the muscle, combined with the geometric arrangement of the motor units with respect to each other and to the electrodes, causes the "random" nature of the resultant emg signal. Considering the way in which the emg signal is generated, it seems unlikely that any detailed characteristics of the waveform of the emg signal should have significance with respect to over-all muscle tension. The usual way of

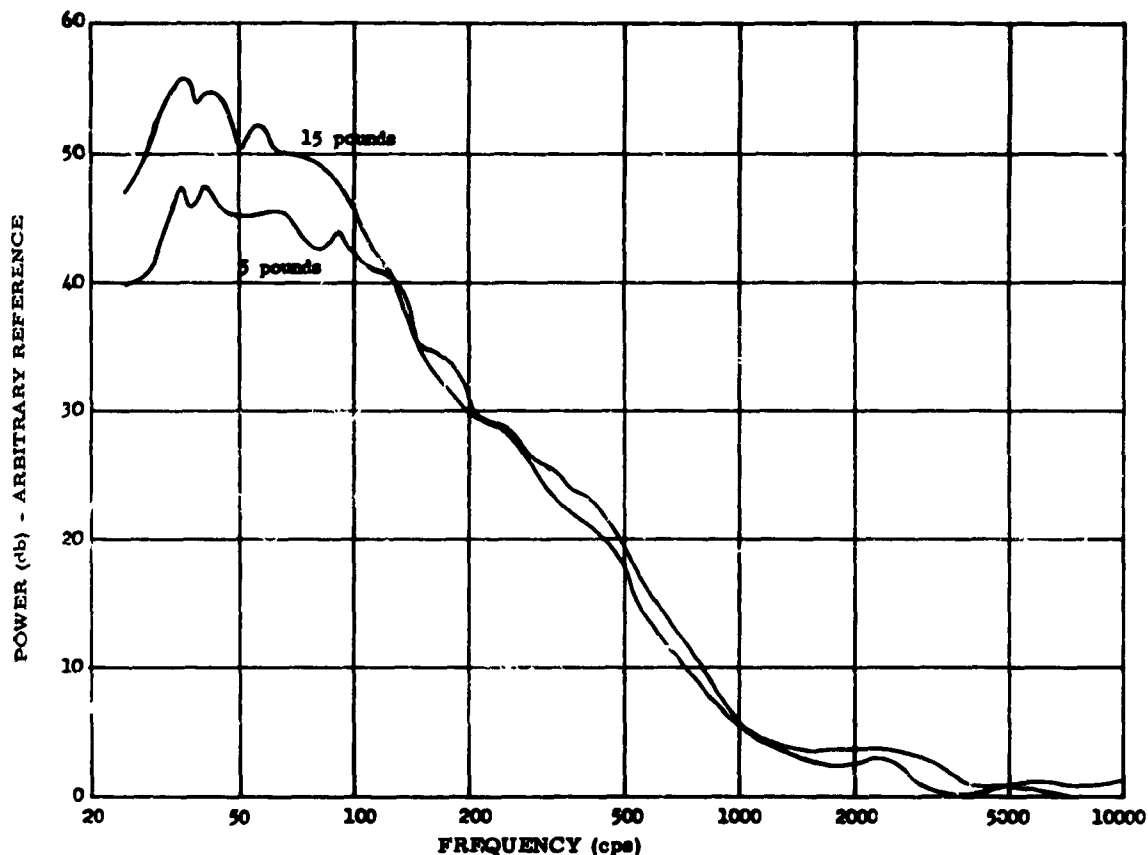

Fig. 11. Power spectra for surface emg signals

Measuring an emg signal has been to consider some average measure of its activity. Various measures of emg behavior were compared by Weltman and Lyman,<sup>145</sup> but they were comparing these measures with respect to their ability to provide discrimination information as to which motion of several was being performed.

There are two measures of emg activity most often described as being informative of the muscle tension. The first is called the "integrated emg," actually consisting of rectification followed by lowpass filtering, the time constant of the filter being long compared with the dominant frequencies contained in the emg signal.<sup>16-18,80,99</sup> The longer the time constant the more precise is the result of this processing, and for constant tension there is no restriction on the length of this time constant. On the other hand, we are concerned with using some processing technique on emg signal while the emg signal is changing its behavior, hopefully in just the same way the emg signal changes its behavior in a normal motion. Thus the time constant should not be so long that the time delay introduced by the filter is an appreciable part of the time taken for the motion itself, or the ability of the patient to control the motion will be badly degraded.

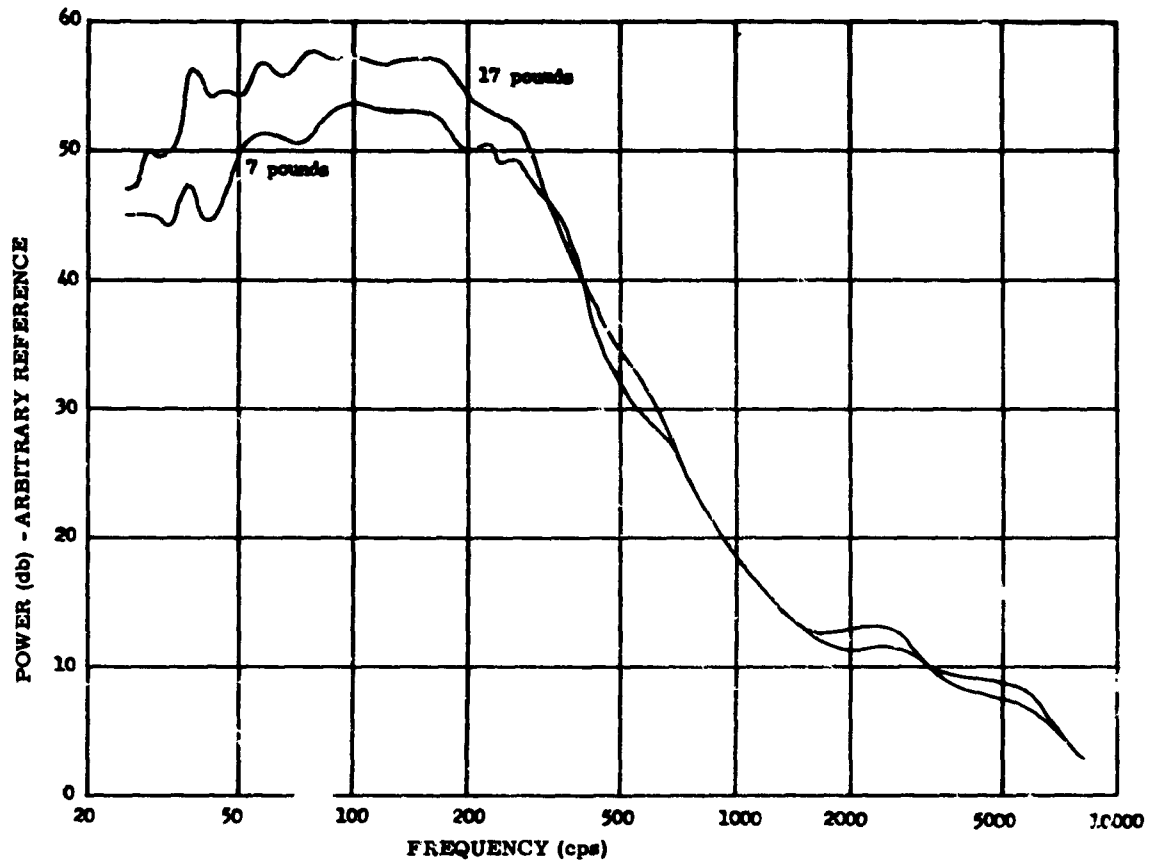

Fig. 12. Power spectra for needle emg signals

There is one other way of measuring emg activity, which has been used by several researchers.<sup>15,142</sup> This consists of counting the number of relative maxima of the emg signal per unit time. Bergstrom<sup>15</sup> compared this measure of emg activity with the "integrated" signal described above, and found these two equivalent, as long as fatigue and motor unit synchronization do not occur. For high tensions, however, when synchronization of action potentials from various motor units is appreciable,<sup>154</sup> it is reasonable to expect that the count of pulses will deteriorate in its accuracy as a measure of over-all activity.

Because of the relative simplicity of implementation of the rectifier-filter combination, in addition to the reasons given above, we chose to use the "integrated" emg as a measure of muscle activity. It remains to study as fully as possible the relation between this "integrated" emg and the tension in the muscle.

Many have reported that the "integrated" emg (hereafter abbreviated "emg") is linearly proportional to muscle tension under isometric conditions; that is, when the muscle length is held constant.<sup>22,80,99</sup> Bigland and Lippold<sup>17</sup> carried this one step further, however, showing that, at any constant velocity of change of muscle length

(including as a special case zero velocity, the case mentioned above), the emg is linearly proportional to tension. The constant of proportionality depends on the muscle velocity, the direction of this velocity, and the muscle length. As the velocity of shortening of the muscle increases, for the same tension in the muscle the emg signal is greater. For lengthening velocities, the emg signal decreases with increasing velocity, at fixed tension.

If we intend to control a prosthesis from the integrated emg signal, then the data above hold a potential difficulty for us: The muscles of the amputee which previously controlled his forearm (in the case of an elbow prosthesis) are no longer connected to his forearm; thus when they are stimulated by the nerves, they may shorten without an opposing load, and their velocity of shortening cannot be either controlled or measured. But without the information as to muscle velocity, the data discussed above tell us that we may not be able to properly interpret the emg signal to deduce from it the desired muscle tension. Under some conditions of amputation, the muscles may instead become attached to the skin or other tissue in the stump; in this case the muscle may be shortening against some load, but its velocity will again not vary with time in any way that we can control or measure. There will be no guarantee that in a given amputee the conditions will not change with time, nor will these conditions be similar from one amputee to another.

As a result of these considerations, it seems desirable that we control the muscle velocity, in order that the operation of the proposed prosthesis be as normal as possible for the amputee. It is possible that through a learning process the amputee might bring himself to control the prosthesis accurately if we ignored the variation of the emg signal with muscle velocity. But, as we have stated, it is exactly this type of compensation on the part of the amputee which we desire to minimize. As a result, in consultation with two orthopedic surgeons, we decided that, if it became necessary, in future amputations to which it is desired to fit our proposed prosthesis the muscle lengths would be fixed, by attachment of the muscles to bone or in any other way possible. Under conditions of fixed muscle length, the relation discussed above between the muscle tension under isometric conditions and the emg applies; under the assumption that the length and velocity are fixed, this relation will not be contaminated by other variations.

In an attempt to verify the data on the relation between emg and muscle tension in isometric contractions, the following experiment was performed: By means of a set of strain gauges mounted to a steel bar, the force applied by a subject's hand was measured while his upper arm was in a vertical position and his forearm was horizontal. Simultaneously, the emg signals from his biceps and triceps were sensed, rectified, and lowpass filtered. We consider the difference between the two muscle forces as the effective force of a hypothetical single muscle, which can apply both tension and compression forces. Accordingly, the signal produced by subtracting the two integrated emg signals was applied to the vertical axis of an oscilloscope, and the force being applied by the hand, as measured by the strain gauges, was applied to the horizontal axis.

The data discussed above led us to expect that the locus of points displayed on the oscilloscope should be a straight line through the origin. (The gain of the triceps channel was adjusted so that the slope of the emg-force relation in pushing down was the same as that on pushing up, thereby compensating for any inherent differences in the two muscles.) In our experiment, the instrumentation was again done digitally, in this case not because it was necessary, but because it was convenient to do so. In the digital program variation of parameters, such as gains, time constants, etc., can be performed with ease, whereas some effort would have to be applied to provide the same flexibility in analog equipment.

In fact, the pattern traced out on the oscilloscope is qualitatively that shown in Fig. 13. Near zero force, the emg-force plot is linear, as expected, but as the tension is increased in either direction, the emg increases more than a linear relation would indicate. Then, when the force is decreased from some maximum value, the emg does not follow the same line it traced out when the force was increasing, but rather decreases more slowly. Thus a double-valued emg-force relation is traced out. In fact, by repeating the same experiment with different maximum values of force, one can determine that the relation is actually many-valued; this suggests the possibility that some variable involved in the relation that is being studied has been ignored. It might be thought that this may be due to the fact that the force-emg relation is different for shortening than for lengthening muscle, but the steel bar bends only very slightly, and the effect is so striking that one hesitates to suspect that the small changes in muscle length which are involved could be the cause. These data were observed simultaneously in England by Bottomley.<sup>21</sup>

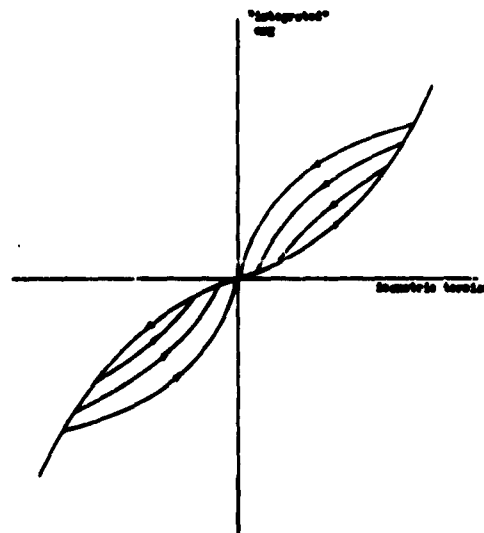

Fig. 13. Multiple-valued nonlinear emg-force relation. Biceps and Triceps surface electrodes. Integrator time constants 300 ms. Relation is qualitative only. Tension measure at hand, elbow angle 90°.

The time constant involved in lowpass filtering the rectified emg signals in this experiment was 300 ms. This value was found to offer a fair compromise between the two requirements that the signal (after the filter) respond rapidly enough to a motion so that the signal and the force remain synchronized, and the time constant be long enough so that at constant tension the signal remain fairly stationary. In spite of the above-mentioned considerations, at constant tension the signal varies from one moment to the next by a sufficient amount that it is very difficult to be certain about details of the way in which the emg-force relation is being traced out on the oscilloscope screen. Nevertheless, there is little doubt that the relation is curved rather than straight, and that it takes on multiple values.

Let us postulate the existence in a given muscle of several different types of motor units, as follows: Let us assume that certain motor units are active only while the muscle is shortening, and others are active when the muscle is lengthening. Let us assume that the motor units that are active in shortening have an emg-force relation that is such that the signal produced while the muscle is supporting a given force is less than that which the motor units that are active in lengthening would produce while supporting the same force. These assumptions lead to an over-all emg-force relation with the multiple values observed by us and described above. The curvature that we observed could be explained by an assumption that such a nonlinearity exists in the emg-force relation of the individual motor units.

We do not suggest that these assumptions represent an accurate picture of the operation of the muscle. We do suggest, however, that the existence of different motor units in a given muscle, with different functions and different emg-force relations, could explain the observations that we have made. There is evidence that motor units do exist with different functions; gradation of activity in a muscle depends on this fact.<sup>18</sup> But in our case it is only the over-all muscle tension that causes different groups of motor units to be activated; whereas to explain the data observed by us the activation of the various types of motor units would have to depend on something other than just the over-all muscle tension. Wagman and Pierce<sup>141</sup> also mentioned certain data on different types of motor units, but their report is not available for reference.

Beyond this theory, this author is unable to advance any reasonable suggestion to explain the curvature and the multiple values observed in the emg-force relation.

### 3 PROPOSED EMG-CONTROLLED PROSTHETIC SYSTEM

The hand, used as a subject for rehabilitation in the three previous studies of emg-controlled prostheses (discussed in Section II), has the property that its normal mode of action is discontinuous. The act of grasping some object consists of two phases: the hand closes on the object at any velocity, while exerting no force; and upon encountering the object, the hand immediately begins applying some force, but its velocity remains thereafter very close to zero. Thus the mode of control changes quite discontinuously from one of velocity control to one of force control. Less often is the



requirement imposed that the hand both exert force and close with some velocity at the same time, such as in the act of "squeezing" to compress some object.<sup>22</sup>

Elbow motion, on the other hand, typically involves the exertion of a force simultaneously with control of motion at some nonzero velocity. And both the force exerted and the velocity of the motion can be varied independently over wide ranges (within the capabilities of the arm). With respect to obtaining the proper emg signals for normal control of an elbow, the anatomy of the musculature which controls normal elbow motion is relatively simple, as compared with hand or wrist motions. Although as many as 6 muscles may sometimes contribute to elbow flexion alone,<sup>60</sup> under most conditions the two muscles, biceps and triceps, contribute most of the required torque for elbow flexion and extension. And these two muscles are large and in the upper layer of muscles in the arm; thus obtaining useful emg signals from them should be quite simple, in that the chance of interference from other muscles is minimal. Finally, the geometry of a piece of equipment to replace lost elbow motion is very simple, there being only one degree of freedom associated with an elbow.

All of the reasons given above combine to make the elbow joint an advantageous subject for an emg-controlled prosthesis. We proceeded, therefore, to design and construct such a device, and to study thereby the effect of various parameter variations on the performance, and to what extent the curvature and the multiple valued characteristics of the emg-force relation would interfere with accurate control. Despite our efforts toward a "normal" behavior, we anticipated that some training of the amputee would be necessary before he could adequately handle the prosthesis; the system that we constructed can be a vehicle for studying this question also. Finally, we have considered the question of what types of feedback from the prosthesis to the amputee would be most valuable to the amputee. This consideration has been based on our observations of the performance of the system in the absence of any feedback other than visual. A suggestion as to how position feedback to the amputee might be implemented in an inherently normal manner can be made.

The steps in the development of this system, and a description of its performance at the present time, follow.

## VI. DEVELOPMENT OF THE PROSTHETIC SYSTEM

### 6.1 SIMULATION OF THE PROPOSED SYSTEM

The purpose of constructing a prosthetic system as a part of our research effort was primarily in order to have available a way of studying the control problem created by the requirements of graded control, using emg as the controlling signal. At the beginning of the construction of this experimental system, there was not yet available a mechanical elbow joint with which to work; the initial approach taken was to simulate such a device on a digital computer. Such a simulation could have been performed on an analog computer, but for several reasons the digital machine was considered preferable. Some of the reasons follow.

1. Variation of various parameters in the simulation could be accomplished on either type of computer, but it was considered easier to provide the required flexibility on the digital computer.

2. In order to properly analyze the control problems associated with the device, the simulation was required to be in real time; that is, the result of some action on the part of the emg signal at the input, was required to produce the proper response at the output, "simultaneously." Only in this way could the interactions between the patient's actions and the responses of the system, and vice versa, be properly evaluated.

Normally a requirement of this sort leads to the use of an analog computer, because certain operations are capable of being performed faster on an analog than a digital computer. In this case it was possible to attain the required speed on a digital computer, as will be discussed below. The requirement that we provide a display of the simulated arm which the subject will find convenient to use, is met more easily on the digital computer.

3. Whereas linear operations are equally simply performed on digital and analog computers, nonlinear operations are more easily implemented on a digital computer. There are exceptions to this statement, but in general it is fair to say that if the various nonlinearities are not to be specified exactly at the beginning, if their interconnections into the system may change from one experiment to the next, or if the nonlinearities are not of certain simple types, then the digital computer provides a flexibility which can handle the nonlinearities more easily than the analog computer does. In this experiment, the dynamical equations for the computation of torques involve trigonometric functions, which, given the time, can be computed more easily on a digital computer than generated on an analog machine.

4. It was not certain at the beginning that the proposed system of processing the emg signal would be satisfactory, nor that any revisions to it which became necessary would be as simple to implement in analog equipment as the initial system would have been. In order to provide complete flexibility for making any such revisions with a minimum of effort, the digital computer was considered a superior choice.

The hypothetical forearm which was simulated was simplified as much as possible. Basically, it was represented in the computer by its weight  $W_P$ , a distance  $d$  from the elbow joint to the center of gravity, a moment of inertia  $I$  about the elbow joint, and a length  $b$  from the elbow joint to a point called the "hand", on which could be placed a point mass with a specified weight  $W_L$ . The torques acting on the forearm resulted from the weight of the forearm, the weight of any object placed in the hand, an angular viscous friction acting at the elbow joint, and the muscular force. As was mentioned previously, the muscular force, derived from the emg signals generated by two muscles, is converted to a form such that it represents the force of one hypothetical "muscle" with the capability of both pulling and pushing. This "muscle" is assumed to act in a direction parallel to the upper arm in the model, and to act at a point on the hypothetical forearm whose distance from the elbow joint  $a$  is specified. Finally, the angle  $\beta$  of the upper arm to the horizontal is specified (in order to know the angle at which that simulated muscle is acting). The above relationships are summarized in Fig. 14.

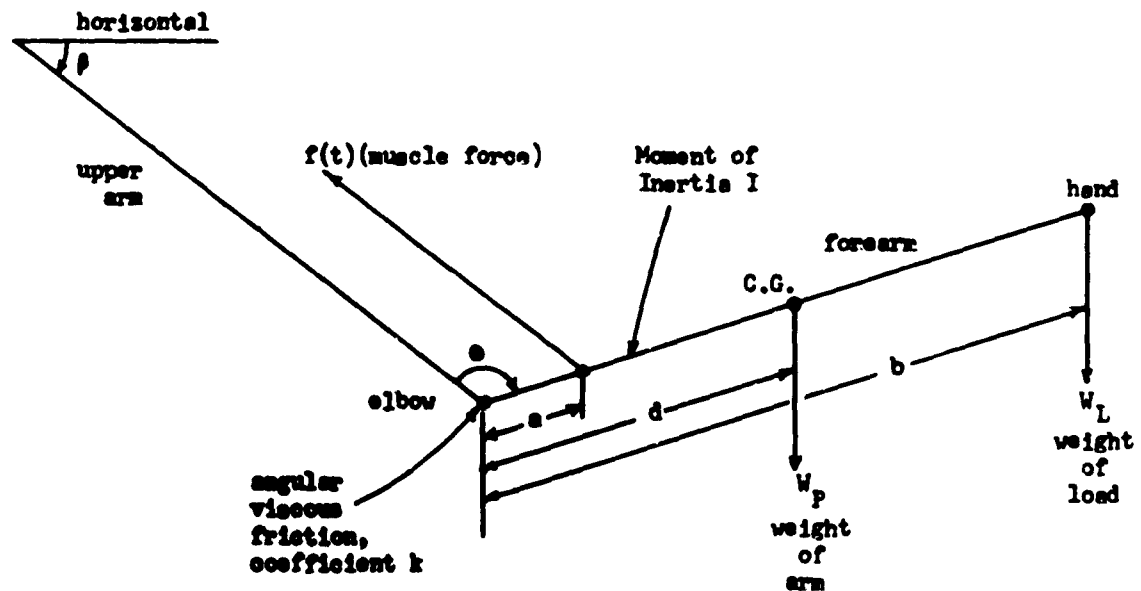

Fig. 14. Idealized arm model used in simulation

The equations governing the simulation are given below; the symbols are defined in Figs. 14 and 15. The total of the torques acting on the forearm, in a clockwise direction is equal to the product of the moment of inertia about the elbow and the angular acceleration of the forearm:

$$-(W_L b + W_P d) \cos(\beta + \theta) - a f(t) \sin \theta - k \dot{\theta} = (I + W_L b^2) \ddot{\theta}. \quad (1)$$

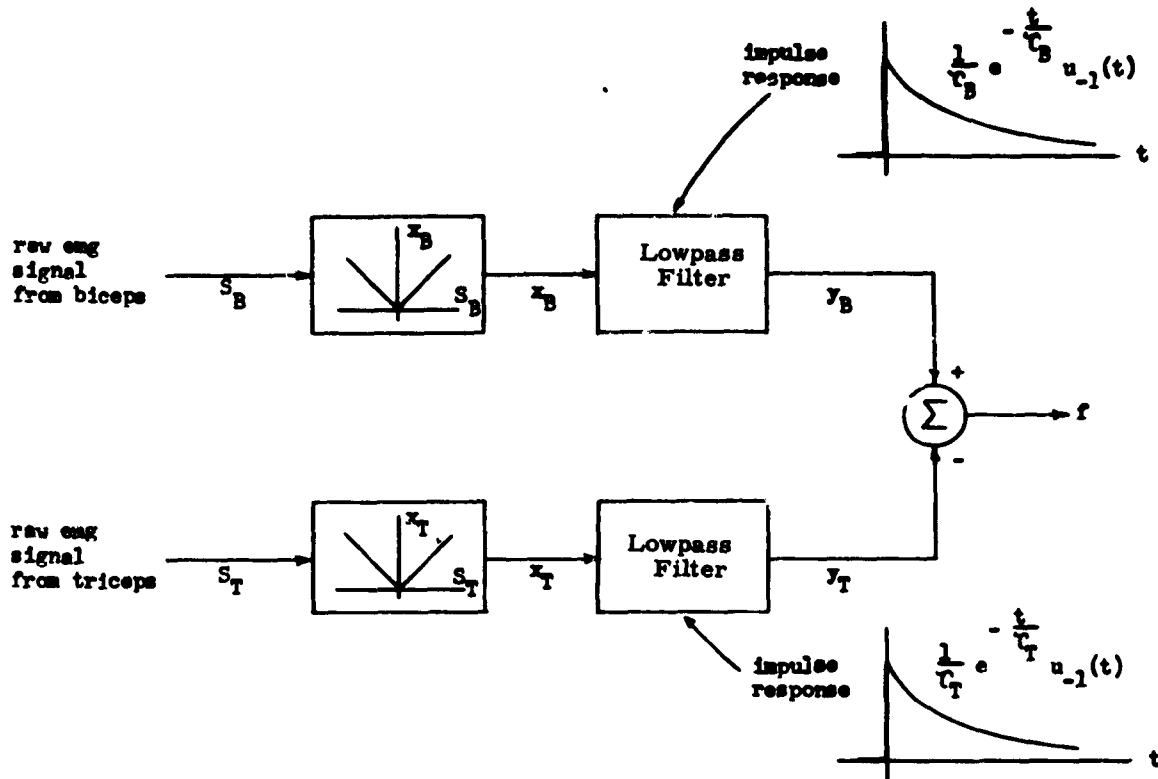

Fig. 15. Block diagram of the emg signal processing

The emg signals derived from the two muscles, biceps and triceps, were initially processed as shown schematically in Fig. 15. Thus

$$f(t) = y_B(t) - y_T(t), \quad (2)$$

where

$$y_B(t) = \frac{1}{\tau_B} \int_{-\infty}^t e^{-\frac{(t-\alpha)}{\tau_B}} |S_B(\alpha)| d\alpha, \quad (3)$$

and a similar relation holds for  $y_T(t)$ .

Equation 1 is a second-order, nonlinear differential equation with constant coefficients. The process of solving these equations simultaneously for  $\theta$  at each instant of time  $t$  consists of sampling the two signals  $S_B(t)$  and  $S_T(t)$  repetitively, at a sampling interval  $T$  to be determined. We use a subscript  $i$  to indicate the interval to which a given sample corresponds. Thus at the  $n^{\text{th}}$  interval, the samples of the biceps and triceps signals are labelled  $S_B(t_n)$  and  $S_T(t_n)$ , respectively. Similarly, from (2),

$$f(t_n) = y_B(t_n) - y_T(t_n). \quad (4)$$

As step 1 of the procedure for computing  $\theta$ , the absolute values of the two emg signal samples can be computed. This is quite straightforward on a digital computer; the program steps necessary to compute the absolute value of one sample of one of the signals on the PDP-1 computer<sup>39</sup> are:

```

lac s      /value of one of the samples of one signal;
spa       /skip the next instruction if that sample is positive;
cma       /otherwise change its sign;
dac x     /and save the absolute value.

```

(5)

(The information to the right of each diagonal is a comment, used here to describe the function of the corresponding instruction.)

The second step in the computation of  $\theta$  consists of determining the output of each of the lowpass filters,  $y_B(t_n)$  and  $y_T(t_n)$ . We can rewrite  $y_B(t)$  from Eq. 3 in the form:

$$y_B(t_n) = \frac{T}{\tau_B} \sum_{k=-\infty}^n e^{-\frac{(n-k)T}{\tau_B}} x(t_k), \quad (6)$$

where we have replaced the integral by a summation of values at sample instants.

Separating the last term in the summation, we obtain

$$\begin{aligned}
 y_B(t_n) &= \left[ \frac{T}{\tau_B} \sum_{k=-\infty}^{n-1} e^{-\frac{(n-k)T}{\tau_B}} x(t_k) \right] + \frac{T}{\tau_B} x(t_n) \\
 &= \left[ \frac{T}{\tau_B} \sum_{k=-\infty}^{n-1} e^{-\frac{(n-1-k)T}{\tau_B}} x(t_k) \right] e^{-\frac{T}{\tau_B}} + \frac{T}{\tau_B} x(t_n),
 \end{aligned}$$

or

$$y_B(t_n) = e^{-\frac{T}{\tau_B}} y_B(t_{n-1}) + \frac{T}{\tau_B} x(t_n). \quad (7)$$

Now, if  $T \ll \tau_B$ , then the exponential form  $e^{-\frac{T}{\tau_B}}$  can be written as  $(1 - \frac{T}{\tau_B})$ , with an

error of the order of  $\frac{T^2}{2\tau_B^2}$ , leading to the difference equation

$$y_B(t_n) = y_B(t_{n-1}) + \frac{T}{\tau_B} \left[ x(t_n) - y_B(t_{n-1}) \right] \quad (8)$$

which is a form that is simple to implement in digital computer instructions. In PDP-1 language, the necessary instruction sequence is

```

lac x      /value of x, this interval;
sub y      /value of y, last interval;
mul c      /a constant, equal to T/rB;
add y
dac y      /new value of y; this interval.

```

(9)

Having used this procedure to determine the two signals  $y_B(t_n)$  and  $y_T(t_n)$ , the "equivalent muscle force,"  $f(t_n)$ , can be obtained from Eq. (4), as step number 3. This force is one of the factors in one term of the total torque about the elbow, according to Eq. (1). Rewriting that equation, attaching subscripts to the time variable, we obtain

$$\ddot{\theta}(t_n) = \frac{-1}{I+W_L b^2} \left\{ f(t_n) a \sin \left[ \theta(t_n) \right] + k \dot{\theta}(t_n) + (W_L b + W_P d) \cos \left[ \beta + \theta(t_n) \right] \right\}. \quad (10)$$

Now we can interpret that equation with respect to the time sequence of events: The torques are computed at the  $n^{\text{th}}$  interval, by using values for angle  $\theta$  and angular velocity  $\dot{\theta}$  at that point in time. By using Eq. (10), the angular acceleration  $\ddot{\theta}$  at that instant is then determined as step 4.

As the last step in the iteration procedure, the angular velocity and position must be extrapolated, and the values of each at the next time interval,  $t_{n+1}$ , calculated, in order that the process can be repeated. The angular acceleration, computed above, is used in these extrapolations. For simplicity, we use a rectangular rule for the integration to  $\dot{\theta}$ . The form of the difference equation is

$$\dot{\theta}(t_{n+1}) = \dot{\theta}(t_n) + T \ddot{\theta}(t_n). \quad (11)$$

The use of Eq. (11) is equivalent to making a stepwise approximation to the acceleration  $\ddot{\theta}$ , under the assumption that a value of  $\ddot{\theta}$  calculated at a point  $t_n$  in time is valid at that time and through the succeeding interval, until  $t_{n+1}$ . The approximation on the velocity  $\dot{\theta}$  then is trapezoidal. Using the following difference equation, we can finally integrate to the angle  $\theta$ :

$$\theta(t_{n+1}) = \theta(t_n) + T \dot{\theta}(t_n) + \frac{T^2}{2} \ddot{\theta}(t_n). \quad (12)$$

The approximation on the angle  $\theta$  is thus parabolic, consistent with the assumption of a stepwise approximation on the acceleration.

The simulation procedure is slightly complicated by the addition of limiters on certain variables; for example, the arm position is bounded so that the angle  $\theta$  is always between  $45^\circ$  and  $165^\circ$ . Although a normal arm can usually be extended to  $180^\circ$ , and often slightly beyond, our simplified model is such that the muscle moment arm about the elbow joint is reduced to zero at  $180^\circ$ . Hence this angle had to be excluded in order that the simulated arm would not "stick" at that position, with no force able to move it from there. A complete block diagram of the system is shown in Fig. 16, showing both the signal processing and the arm dynamics.

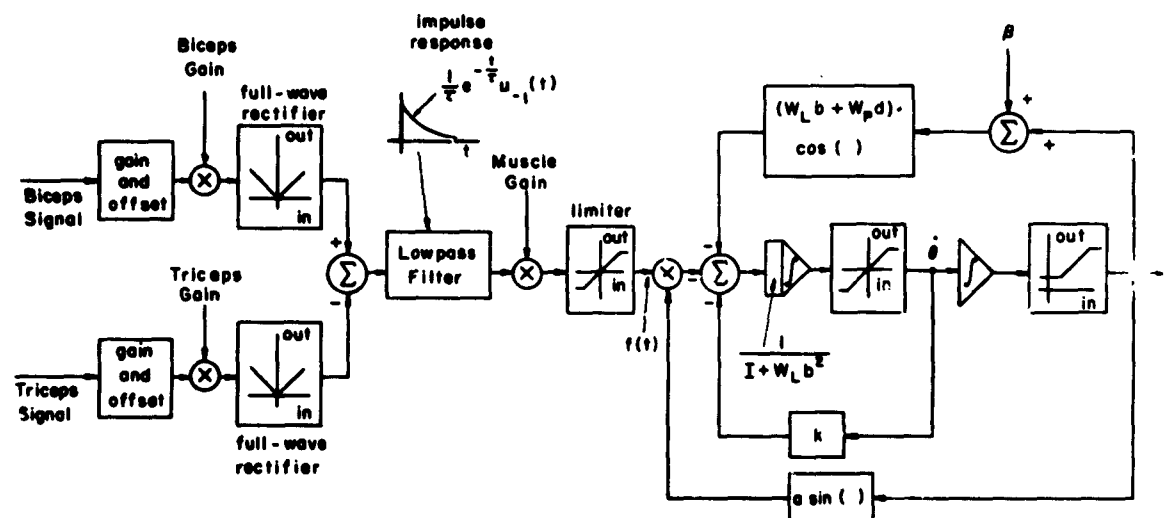

Fig. 16. Block diagram of over-all simulation program

Except for the limiter on the elbow angle, the others were there mainly to inform the operator when any of the bounds were exceeded, since in each case the limits imposed were large enough that under normal conditions they should not be exceeded. A light on the computer console was connected to each of the other limiters by the program, so that the light was lit when the bound was being exceeded.

In practice, it was found that the adjustments for time constant of the two lowpass filters were so broad that there was no basis on which to choose different values for them. Thus their values were always equal, and this fact allows a simplification of the processing diagram, as shown in Fig. 16. Because the time constants are equal, the two emg signals occur before this filter, rather than after it. This simplification is purely a formal one, however; that is, it does not imply that the difference between the two absolute values of the raw emg signals has any significance. The result of the signal processing, however, is identical to what it was before.

At the end of the iteration process described above, the loop must begin again. The time taken to perform the process once varies from one time through the loop to the

next. This is because the times for the execution of multiply and divide instructions vary, and because certain instructions or groups of instructions are skipped sometimes and executed other times, depending on the partial results of the calculation. (For example, in determining the absolute value for one of the signals, in Eq. (5), the "cma" instruction is skipped if the sample value is already positive. The time for one execution of that sequence of instructions alone will be either 25 or 30  $\mu$ sec, depending on the data value.) These variations in time for the processing would cause corresponding variations in the times at which the various signals were sampled, and it would not be possible to carry out the calculations indicated in (9) or the integrations in (11) and (12), since the sampling interval would be varying and there would be no way for the program to determine the value of that sampling interval at each instant. Thus, the beginning of each pass through the processing loop must be synchronized to a "clock", which generates pulses to the program at regular intervals.

The PDP-1 available at the Research Laboratory of Electronics, M.I.T., has, in addition to analog-to-digital conversion hardware and certain special instructions, a very flexible panel at which other external hardware can be connected for signalling the program or receiving signals from the program. Accordingly, a variable clock was connected at this point, and the program was written to wait for a "sequence break" caused by this clock before initiating a pass through the sampling and processing loop. At the completion of the processing, the program would wait, with time available, until the next clock signal. By this means the sampling interval was kept constant.

One of the features which thus far has not been mentioned about the program is the mode of output. This was in the form of a moving display on a large program-controlled digital display oscilloscope. An example of the form of the display is shown in Fig. 17. The two radial lines that are very close together represent the upper arm, and these remained static throughout a given computer run. They could be moved to a new angle, by entering into the program a new angle between the upper arm and the horizontal; that angle for the case shown in Fig. 17 was  $90^\circ$ . The center of the screen represents the elbow joint, and the third radial line represents the forearm. This line moved as the program was running, and continually represented the position of the simulated forearm. The study of control performance was accomplished by placing the subject in front of the display, with electrodes mounted to his biceps and triceps muscles, and instructing him to attempt to lift and otherwise control the line position as if it was a prosthetic forearm, through actions in his muscles.

The display must be updated continually by the program; its persistence is fairly low. On the other hand, some degree of flicker in the display is acceptable; in most cases it is not noticeable. Thus the program, instead of doing nothing while it is waiting for the clock signals mentioned above, was written to make use of this time to regenerate the display. The "sequence break" caused by the clock also caused all information about what point the program was displaying to be saved, and upon completion of the processing required for that clock interval the program returned to the point where it was interrupted, continuing the display where it left off.





Fig. 17. View of the aluminum and steel for operation.

There is a set of knobs on the computer, which can be used to enter values into the program. Individual "gain" controls on the biceps and triceps signals, and one gain control on the difference between them, were programmed on those knobs; thus, for example, when it was found that too much biceps effort was required for the force being lifted, the gain could be increased easily. Other parameters in the program could also be varied, but in most cases this required typing a number into a certain register, rather than changing the values dynamically. A change of this sort would only take 10 seconds, after which the program could be restarted, so the time lost was still negligible.

The processing to be performed per sample required about 2.5 msec of computation. This sets a lower bound on the sampling interval. To allow for a reasonable amount of time for replenishing the display, a 3 msec sampling interval was chosen. This required a strict bandlimiting of the emg signals so that no "aliasing" of the high frequency components would introduce noise into the signals. The Sampling Theorem<sup>106</sup> requires, for a 3 msec sampling interval, that no frequency components exist in the signals to be sampled above about 166 cps. We chose to lowpass filter the signals to approximately 100 cps, with a corresponding slight loss of signal information. We are fortunate that the spectrum analyses described in Section V proved that, with respect to the emg-force relation, any portion of the power spectrum of the emg contains as much information as any other. This permits us to eliminate any chosen bands of frequency components in the emg signal, yet be certain that we are not losing any important information, and that the distortion of the signal which we are causing will not affect our results. It should be noted that the filter being discussed here is distinct from that filter described above as a part of the program, and being an important part of the required signal processing; the filter being discussed here is one which cannot be implemented in the computer program, because to do so would presuppose some sampling procedure. It is just this sampling procedure which we are making meaningful by the addition of this external analog filter.

The program which implemented this simulation requires approximately 2400 of the 4096 registers of PDP-1 storage. A great deal of the program consists of calibration and other introductory subroutines, which are not an important part of the simulation per se. The actual arm simulation loop requires about 400 registers.

Many of the limiters shown in the processing block diagram of Fig. 16 were placed there only as an aid to the further development of the program. The signal processing has remained as simple as it is only because none of the variations which were attempted succeeded in improving the overall performance. One feature which initially was included in the system is a "dead zone" between the lowpass filter in the signal processing and the computation of the torques. This "dead zone" had a form such that small variations in the processed signal at this point were not passed on to the dynamics of the arm. This device seems to be a useful improvement in theory, but in fact its heuristics are

wrong: certain of the small variations which this system failed to pass on to the dynamics were the perfectly reasonable attempts of the subject to compensate for so small errors in the behavior of the system. Thus the proper type of device to insert this point would know how to distinguish between these two types of small variation in the processed signal. Unfortunately, insufficient information about the characteristic of the emg signal is available to allow us to make this distinction. As a result, the system has been left as shown in Fig. 16; its performance in that form is superior to that which was attained with any "backlash" generator or other variations which were attempted.

We have stated previously that, in order to properly process the emg signal and derive the force information from it, it was desirable that the lengths of the muscles which were generating the emg signals be fixed. In fact, although the simulated arm moves quite readily if the subject is a normal person and he makes any movement of his arm, it is very difficult for a normal person to control the movements of the simulated arm in this manner, although an amputee may not have the same difficulty. All of the conclusions drawn in this work, and all of the opinions stated, with reference to the performance of the simulated arm described above, are the results of experiment with one subject, this author, who created the situation of fixed muscle lengths in his arm by holding the edge of a table with his hand as he applied lifting or pushing force to control the simulated prosthetic arm. Although there may be some degree of internal shortening of the muscles in such a case, against the elasticity of the tendons, it is thought that this amount of shortening probably exceeds the amount which may be remaining in an amputee's arm when his muscles have been "fixed." If this is so, then the fact that satisfactory performance was achieved with the subject as described suggests that the results should also be satisfactory with an amputee.

With the arm simulation and signal processing as described, the author was able to control the arm position quite well when there was sufficient viscous friction in the simulated elbow joint. As the viscous friction was decreased, the arm velocities would increase to the point that little control was possible. The time constant in the signal processing was required to be a minimum of 300 ms., in order that the variations in the resultant processed emg signal were small enough that the random arm motions were in turn acceptably small. All evaluations on the resultant degree of control of the simulated arm are qualitative only, but a good test of the ability of the system was found to be an attempt by the subject to hold the simulated arm in some fixed position for 15 seconds or longer. If the motions of the arm during such a test were judged small enough to be acceptable, then the set of parameters which enabled that result to be achieved was considered acceptable. For conditions under which the above performance was satisfactory, it was also possible for the subject to control the velocity of the arm motion.

The performance of the arm was very critical; that is, it seemed to respond to small variations in the muscular effort more rapidly than seemed consistent with the

maximum velocity which it could attain with the same set of system parameters. It is possible that by the insertion of nonlinear friction losses, such that the starting friction would exceed the moving friction, the performance might have been improved. There are probably other specific improvements which could have been made, but no further refinements were attempted. The work on the arm simulation was terminated at this point, for reasons discussed below.

Generally speaking, the study of emg control which was carried out through the simulation effort described above served very well to allow determination of the form of the signal processing system, and to demonstrate that graded control of prostheses through voluntarily-generated emg signals was feasible. However, it was not possible, with the crude arm model which was simulated, to draw conclusions about the precision of the control which was possible.

A mechanical arm was being developed for this project by another worker; this device was ultimately planned as the research prototype for an emg-controlled prosthetic system which could be tested with amputees. It became clear that this artificial arm would contain certain mechanical characteristics which were different from those in a normal arm, and which were also different from those in the simulated arm model described above. The fact that these mechanical characteristics differed from those in a normal arm made it advisable that we not continue to refine the simulation of a normal arm model, but rather begin to study the way in which the particular characteristics of this artificial arm would affect the ability of a subject to control it. On the other hand, the very complex nature of certain features contained in that device made a simulation of its performance, in a manner similar to that described above for the simplified arm model, very difficult. An algorithm was deduced which would have simulated the action of that arm fairly accurately, but its implementation on the PDP-1 computer would have required an estimated ten milliseconds of computing time for each "pass" through the processing loop. This would in turn have required such a low upper-frequency bound on the emg signals that the attempt to simulate that arm was abandoned. The artificial arm itself was at that time close enough to completion that it was decided to create a system which controlled that arm through the emg signal processing which had already been developed, and to continue the development work as applied to that system.

We digress at this point to discuss the features of the arm, which have significance for our work.

## 6.2 THE PROSTHETIC ARM

During the phase of the research which was described above, a parallel development was being carried on, in order to produce a prosthetic elbow suitable for emg control.<sup>126</sup> The purpose of this phase of the work was to make available an actual prosthetic arm which would enable the continuation of the research effort towards learning more about the problems of emg control. The arm so developed was intentionally designed so that,

should it become desirable to do so, it could be mounted to an above-elbow socket and actually fitted to an amputee in order that his experiences in using the device could be better studied.

We shall now summarize the features of the arm, developed by Rothchild, which play a part in our work. More detailed information on these and other innovations included in the design of the arm can be obtained by referring to Rothchild's report.

In order to support a weight with a standard prosthesis, either the subject must exert a continuous effort, or he must lock the elbow joint. In externally powered prostheses, the exertion of continuous effort on the part of the system will normally result in rapid exhaustion of the power supply. The inclusion of a separate locking device, however, which must be operated by the subject, creates a system which is inherently dissimilar from a normal arm. The usual solution to this difficulty has been the inclusion of a self-locking screw mechanism,<sup>22</sup> which unfortunately carries high frictional losses. It is certainly desirable in an electrically-operated device that the losses be minimized; because supporting a weight in a fixed position is a very common occurrence, it became necessary in our system to minimize the amount of battery power required for that activity. Hence one of the design constraints on the electrically powered arm was that it be able to support a weight in any fixed position indefinitely, with nominally zero drain on the battery.

The solution to that part of the arm design was accomplished by Rothchild by including a unique mechanical clutch in the drive train of the arm. This clutch performs the function of allowing the motor to move the arm up or down, but of fixing the arm position when the motor power is off, independent of the load. Thus the load cannot cause motion of the elbow joint when no signal is applied to the motor, but the motor can move the arm in either direction.

One by-product of the inclusion of that clutch, however, is the fact that now the load had no effect on the muscular effort necessary to maintain elbow position. Such a mode of performance is inherently not normal, for it is a common experience that the effort necessary to support a heavy weight in a normal hand exceeds that necessary to support a light weight. This is doubtless one of the ways (if not the most direct way) which force information is fed back to the human, through the knowledge of the effort which he is exerting in order to support the opposing load.

Thus, as a further innovation in the development of the arm, to compensate for the effect of the inclusion of that clutch, Rothchild specified a set of strain gauges on the arm, placed in such a position that they measure (approximately) the total load torque about the elbow. He specified that this signal be fed back to the motor control circuit in such a way that the motor signal is reduced to zero, causing the arm to stop moving at any point, only when the effective muscular torque equals the load torque, as measured by the strain gauges.

The input to the arm, to cause its elbow to move, is a direct input to a dc motor, the polarity of the input signal specifies the direction of travel of the arm, and the

magnitude of the signal applied specifies the strength of the effort with which the arm should attempt to move. Due to the changing motor velocity, the resulting changing armature voltage, and the various other nonlinear losses in the system, the linear force produced in the arm's "muscle" is proportional to the applied voltage only at constant velocity. Due to the complex geometry of the arm, the torque about the elbow, produced by a given input signal to the motor at some constant speed, depends on the arm position at that instant in a different way than the torque produced by a given effort in a real muscle does. The nonlinearities which are involved in these relations are quite complex and it is difficult to compensate for them; as a result, it is possible that at certain angles of the arm the subject may anticipate through his experience with a normal arm that some certain effort will be required, but because of a more favorable lever arm than the person's experience is aware of, the effort resulting in the artificial arm may be greater than intended. This is one of the areas where the ability of the patient to adapt to small variations from the normal arm's characteristics is necessary.

### 6.3 EMG-CONTROLLED PROSTHETIC SYSTEM

In order to integrate the artificial arm into the emg control system which was developed through the simulation study, it was necessary to modify the program which was used previously. The simulation of arm dynamics was removed, and that section was replaced with the necessary program sequence to apply the proper control signal to the arm. The block diagram of the motor control loop, including the connection of the feedback signal from the strain gauges, is shown in Fig. 18. The strain gauge signal is shown as indicated in Fig. 18 because, in fact, only under static conditions is that signal actually proportional to the total torque; inertial forces will produce transient signals at that point also.

The motor control portion of the program is quite simple. Again, there are certain aspects of the program which are not shown in Fig. 18, but in principle the program needs only to sample the strain gauge signal once each time through the processing loop, compute the difference between that signal and the result of the emg signal processing, and transmit the result back out of the computer to the motor. The signal-processing section of the simulation program is retained intact, and the computation of arm position through the application of the equations for the dynamics of the simulated arm and load has been removed.

The computation which is now involved in the program is quite simple. In fact, except for the flexibility to make gross revisions to the overall block diagram that is involved in translating the emg signals into the required motor signal, there is no further need for the computer. Its functions are now reduced to those of several adders, amplifiers and one low-pass filter, which could be implemented easily in analog instruments. The computer has been retained as part of the system at this time for only two reasons: The existence of the large part of the program which was carried over intact from the simulation to the present operation made it easier to produce a working system

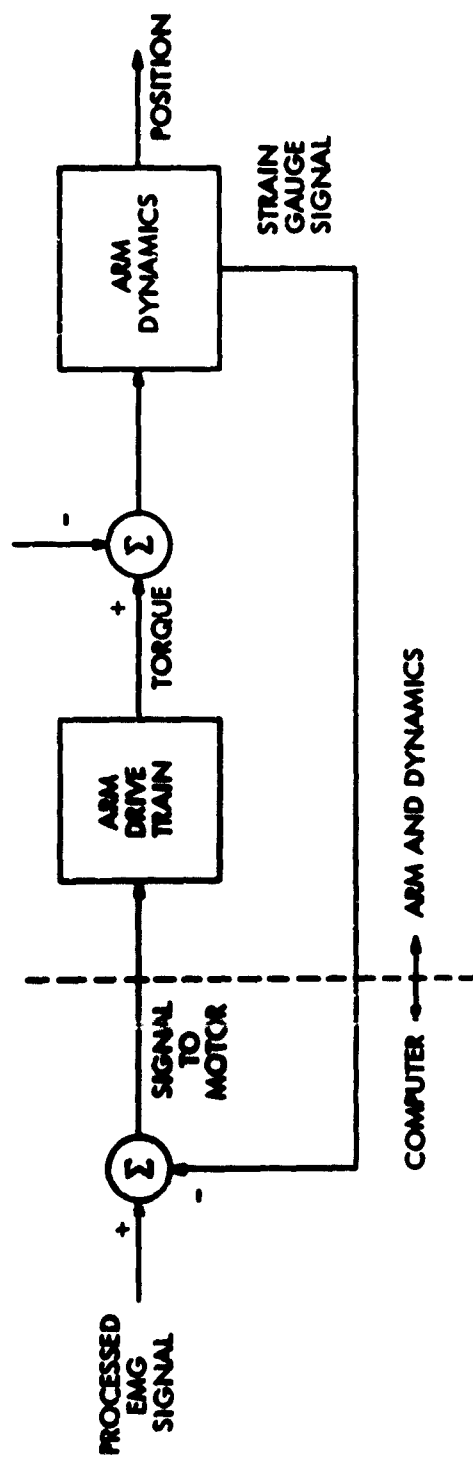
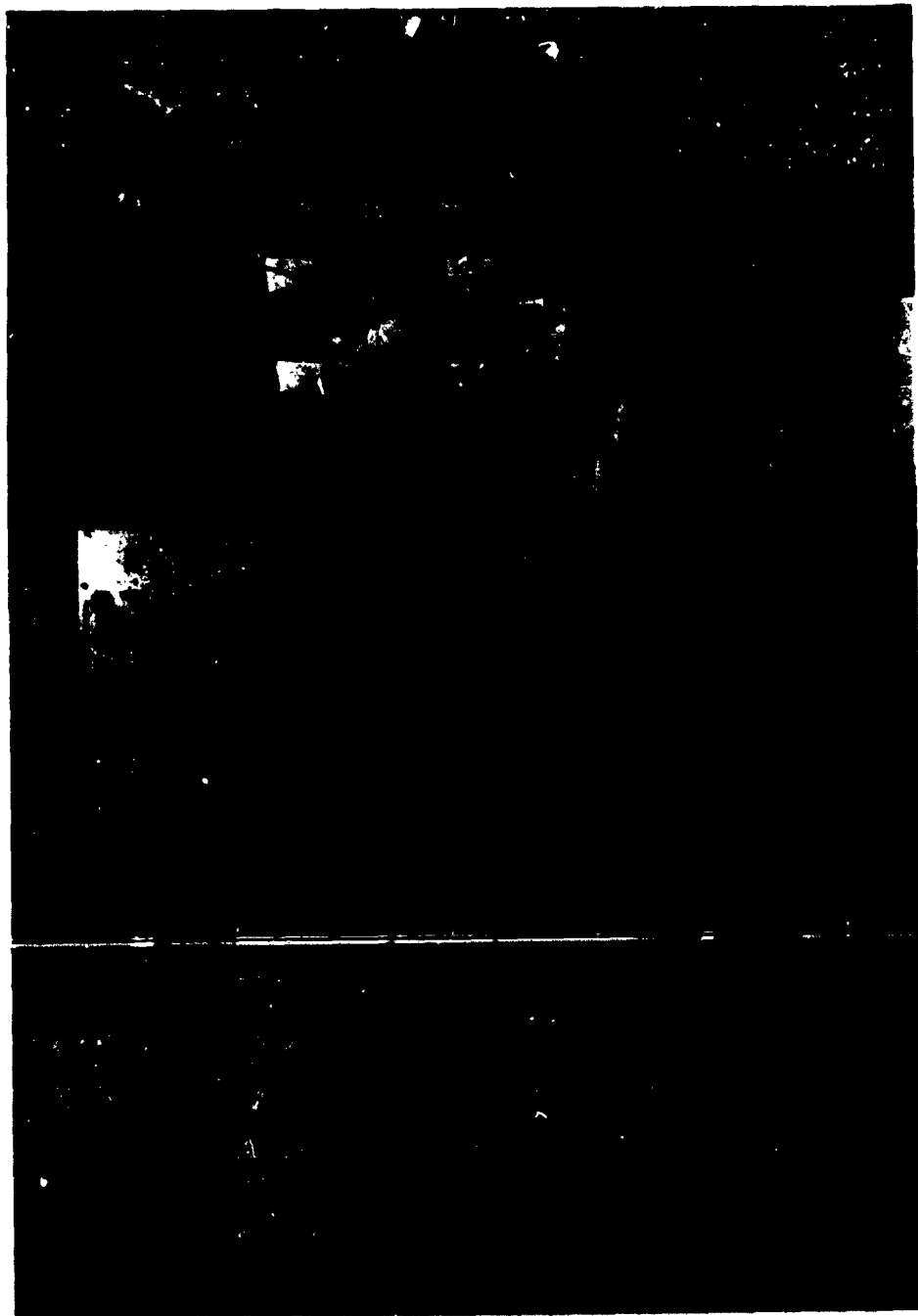
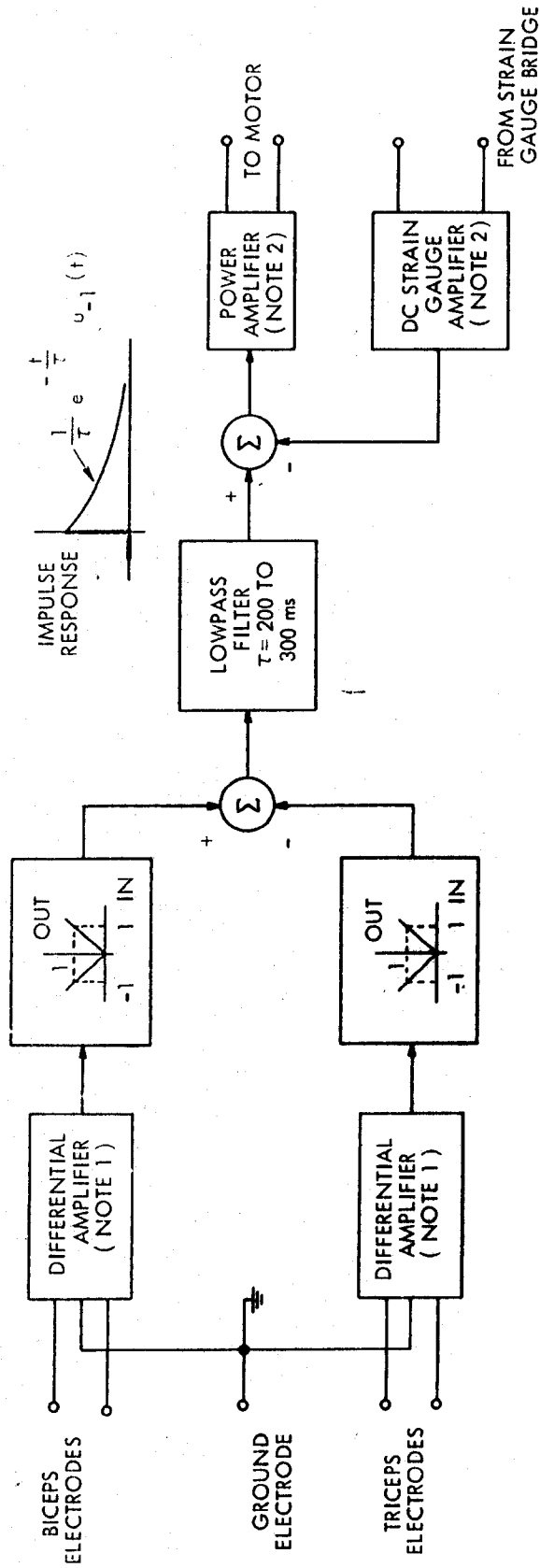

Fig. 18. Block diagram of the motor control loop in the arm-operating program



**Fig. 19.** View of equipment used in operating the prosthetic arm.  
(Photograph by D. Moffitt.)





NOTE 1. AC DIFFERENTIAL AMPLIFIERS :

DIFFERENTIAL GAIN ADJUSTABLE 1000 TO 10000.  
 GOOD COMMON MODE REJECTION.  
 DIFFERENTIAL INPUT IMPEDANCE  $\geq 1 \text{ M}\Omega$ .  
 BANDPASS NEED NOT BE WIDER THAN 10-500 cps.  
 IT MAY BE SOMEWHAT NARROWER, AND IS NOT CRITICAL.  
 GAIN MAY NEED TO BE INCREASED IF BANDPASS IS TOO NARROW.

NOTE 2. DC POWER AMPLIFIER :

OUTPUT IMPEDANCE ADJUSTABLE 1-10  $\Omega$ .  
 OUTPUT VOLTAGE SATURATING AT  $\pm 26$  volts.  
 OUTPUT CURRENT PEAK 8 amps, AVERAGE 2 amps.  
 VOLTAGE GAIN ( OPEN-CIRCUIT )  $\approx 500$ .

NOTE 3. DC STRAIN GAUGE AMPLIFIER :

AMPLIFIER, STRAIN GAUGES, AND STRAIN GAUGE SUPPLY VOLTAGE SHOULD BE CHOSEN SO THAT AMPLIFIER OUTPUT VOLTAGE VARIES BETWEEN  $\pm 200 \text{ mV}$  WHEN LOAD IN PROSTHETIC HAND IS VARIED BETWEEN  $\pm 10 \text{ lbs}$  AT AN ELBOW ANGLE OF APPROXIMATELY  $125^\circ$ . GAIN SHOULD BE ADJUSTABLE OVER A RATIO 10 : 1 UP TO THIS VALUE.

Fig. 20. Equivalent analog prosthetic control system to that now requiring the computer. (In the specifications it is assumed that the mechanical arm is unchanged from its present form.)

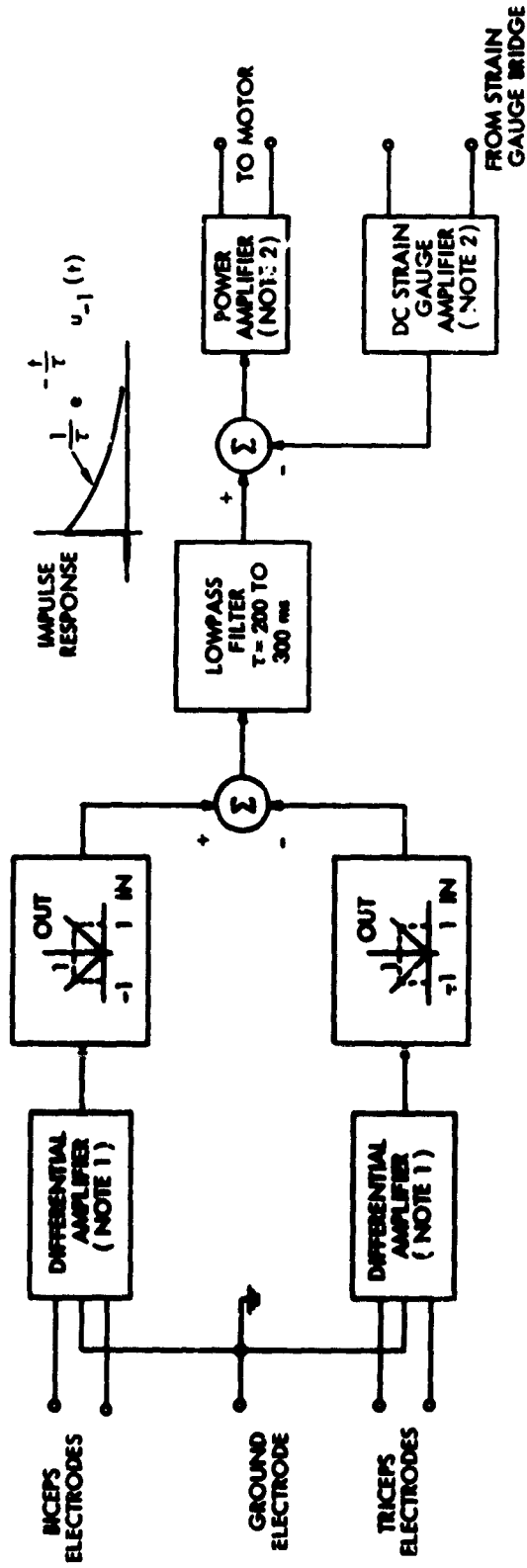

**NOTE 1. AC DIFFERENTIAL AMPLIFIERS:**

DIFFERENTIAL GAIN ADJUSTABLE 1000 TO 10000.  
 GOOD COMMON MODE REJECTION.  
 DIFFERENTIAL INPUT IMPEDANCE  $\geq 1$  M $\Omega$ .  
 BANDPASS NEED NOT BE WIDER THAN 10-500 cps.  
 IT MAY BE SOMEWHAT NARROWER, AND IS NOT CRITICAL.  
 GAIN MAY NEED TO BE INCREASED IF BANDPASS IS TOO NARROW.

**NOTE 2. DC POWER AMPLIFIER:**

OUTPUT IMPEDANCE ADJUSTABLE  $\approx 10 \Omega$ .  
 OUTPUT VOLTAGE SATURATING AT  $\pm 26$  volts.  
 OUTPUT CURRENT PEAK 8 amps, AVERAGE 2 amps.  
 VOLTAGE GAIN (OPEN-CIRCUIT)  $\approx 500$ .

**NOTE 3. DC STRAIN GAUGE AMPLIFIER:**

AMPLIFIER, STRAIN GAUGES, AND STRAIN GAUGE SUPPLY VOLTAGE SHOULD BE CHOSEN SO THAT AMPLIFIER OUTPUT VOLTAGE VARIES BETWEEN  $\pm 200$  mv WHEN LOAD IN PROSTHETIC HAND IS VARIED BETWEEN  $\pm 10$  lbs AT AN ELBOW ANGLE OF APPROXIMATELY  $125^\circ$ . GAIN SHOULD BE ADJUSTABLE OVER A RATIO 10 : 1 UP TO THIS VALUE.

Fig. 20. Equivalent analog prosthetic control system to that now required by the computer.  
 (In the amplification it is assumed that the computer is used.)

by retaining the computer as a block in the system than to do otherwise; and although the form of a working system had been demonstrated through the simulation studies, the specific parameters had not been set, and the differences between the mechanical arm and the simulated arm were significant enough to indicate the need to retain experimental flexibility.

The changes necessary to operate the mechanical arm have been minor however. The arm displays some mechanical slack, and some significant starting friction. These characteristics actually help to smooth the operation so that the extreme sensitivity apparent in the simulated arm has disappeared. The time constant involved in processing the emg signals has now been reduced to 200 to 250 ms., resulting in slightly faster response to rapid inputs, with no decrease in the ability of the subject to control the arm position. In fact, the subject can control the mechanical arm more accurately, with respect to speed control while the arm is moving, and with respect to stability in one position when that is desired, than was possible with the simulated arm.

With the emg signals removed from the system, but the strain gauge signal connected normally, the arm can be manually lifted and dropped, and, by varying the gain of the strain gauge signal, its "feel" can be adjusted to be similar to that of a normal arm. In this mode, the strain gauges are the source of the signal which allows the motion of the arm up or down. If the strain gauge signal is also removed, or the motor is disconnected, then the arm cannot be manually moved, since it is the function of the clutch to prevent such motion. It is only because of the signal from the strain gauges that the arm can, for example, fall of its own weight when the emg signals are removed by the subject's relaxing his muscles.

If the strain gauges were not there, but the clutch were, then relaxing the muscles when the arm was at some point would result in the arm's remaining at that point indefinitely. This would result in the subject's having no awareness whatsoever of the force he was supporting. The addition of the strain gauges, however, provides the system with the normal characteristic of requiring continuing muscular effort in order to support a weight in a fixed position.

A view of the computer room and the equipment necessary for running the system in the form described above is shown in Fig. 19. For reference purposes, a block diagram of an equivalent analog system which should produce performance substantially similar to that obtained as above, is shown in Fig. 20. The specifications for the various elements in that diagram are given there also.

## VII. EVALUATION OF THE SYSTEM - SUGGESTIONS FOR THE FUTURE

### 7.1 OVER-ALL SYSTEM PERFORMANCE

At present the system can only be operated in the configuration shown in Fig. 19. One rack of equipment serves to translate the analog signals derived from the two muscles and from the strain gauges into the proper format for input to the computer. The DEC PDP-1 computer is a part of the system; the arm-operating program tape, prepared by this author, serves to cause the computer to perform the necessary signal processing of the emg signals. A second rack of equipment holds the arm itself and its associated power supplies, and receives from the computer the necessary signal for activation of the motor in the arm. The electrodes used are those already described,<sup>13</sup> because of their relative lack of motion artefact, and excellent contact with the skin over long periods of time.

Thus far, only two persons have operated the prosthetic system as subjects. One, the author, has been the subject many times. The author has two normal arms, and on different occasions either arm has been used as the signal source. The condition of fixed muscle length was simulated in all these cases by the author's holding the edge of a table, or otherwise preventing elbow motion as his biceps and triceps muscles were tensed. The positions for the electrodes were never marked, and no other precautions were taken to ensure placing the electrodes in identical positions on different days. The electrode placement was always determined simply by the criteria that the two electrodes should be placed over the largest portion of the muscle when that muscle was flexed, as determined by palpation.

In the case of the author the emg signals reached a level of about two millivolts rms in a fairly strong contraction. The signal obtained from the triceps was weaker than that seen at the biceps. The author was able to energize either muscle selectively while relaxing the other; under these conditions there was no observable signal from the electrodes over the relaxed muscle. When both muscles were intentionally relaxed, the biceps signal decreased at least by a factor of fifty from its maximum, and the triceps signal decreased to a comparable level.

The other subject was involved on only one occasion. He was a unilateral medium above-elbow amputee. He was approximately 55 years old, and his amputation was about 25 years old. He regularly wore a prosthesis of the conventional type, with two cables: One cable, operated by a shrug of the shoulder on the amputated side, controlled locking and unlocking of the elbow. Pulses of tension performed alternately the locking and unlocking actions. With the elbow unlocked, flexion of the shoulder caused flexion of the elbow joint through the second cable. With the elbow locked, flexion of the shoulder (or a shrug of the opposite shoulder) caused opening of the terminal device (hook), which was normally closed. During the 25 years since his amputation, he had not used his biceps and triceps on the amputated side, and he had learned to associate motion of the elbow on that side with shoulder motion rather than with activity of the biceps and triceps muscles.

Because of the short stump length, this amputee had very little of either of his biceps or triceps muscles remaining. Further, because of the long time since those muscles had been used, they showed a considerable degree of atrophy. It was very difficult to feel the positions of the muscles through the skin, and so electrode placement was somewhat difficult. Nevertheless, the electrode positions were chosen simply by palpation and no readjustment of their positions was found to be necessary. The signals observed from his muscles never exceeded about 500 microvolts rms. The biceps and triceps showed about the same maximum emg levels.

At the beginning of the experiment with this amputee, we found that his ability to selectively energize his two muscles (biceps and triceps) had been lost. When asked to energize his biceps alone, not only did he energize his biceps as requested, but the triceps was also energized. The emg signal observed on the triceps was approximately one-third of that observed at the biceps, and by palpation it was clear that there was a significant contraction in the triceps as well as biceps. His efforts to energize his triceps alone, however, were less successful: In this case, the signals observed at the two electrode sites were about equal.

The total training time that this amputee received in the use of the prosthetic elbow consisted of one two-hour session. By the end of this session, it was remarkable to observe the extent to which his ability to selectively energize the two muscles had returned. The signals observed on his two muscles had each almost doubled, for approximately the same effort, and he could cause the signal observed in the triceps to exceed that in the biceps by about a factor of three. This degree of increase in his ability in such a short time exceeded our most optimistic hopes. By the end of the session he was able to control the arm position very well.

Either of the two subjects was able to lift the arm to any position in its range, while carefully observing its position visually. This was possible with the arm either unloaded or with a load as great as two pounds on the terminal device. Either subject could hold the arm in that position, with only small motions about that position, for a period as long as thirty seconds, as long as it was possible to concentrate on that task both visually and mentally. Either subject was able to move the arm smoothly, controlling the velocity of the motion as desired.

Either subject was able to control the force which was being exerted by the arm against a load; the undesired variations in this force were proportionally somewhat greater than were the undesired variations in position mentioned above. There are several possible causes for this observation. One possibility is that the means of feedback to the subject of the arm's performance, which was in these cases only visual, is considerably more efficient at sensing a change of position, than a change of force. Another possibility is that, mathematically, position is the second integral of force, and the smoothing action of two integrations would be expected to cause the percentage variations in position to be smaller than the variations in force. With respect to this suggestion, we must keep in mind that these measurements apply to different

experiments: The undesired variations in force relate to an experiment in which the goal verbally posed to the subject was to hold the force constant, irrespective of variations of position, and it is these positions which are the second integral of the forces discussed. In the case where the position variations were measured, the task was to maintain a fixed position, irrespective of the forces necessary. Finally, it is worth noting that the control of force in the normal person is itself probably not as effective under certain conditions as the control of position, as discussed in Section III.

There is a simple experiment which serves to investigate the "response time" of the overall system, as follows: Someone holds the arm in position while the subject uses his emg control to exert a force against the person's hand. The arm is then released without warning, and the subject must return it to its former position as quickly as possible. The typical response in the case of our system includes an oscillation of the arm position about the desired position, at a rate as slow as one cycle per second under some conditions, settling at the desired position within approximately four seconds. There is, however, considerable variation in the details of this response from one attempt to the next. These variations are to some extent related to the mental attitude and "voluntary tension" of the subject, with respect to whether he is "tense" or "relaxed". In Okabe et al,<sup>168</sup> similar observations in the wrist position control system in normal subjects were described. The limiting factor with respect to the frequency of the oscillation about the final position in our system seems to be the time constant used in the signal processing; this will be discussed further in Sec. 7.3.

The details of the system as employed for the two subjects varied slightly, as will be described subsequently. The major difference between the performances of the system with the two operators was the fact that the undesired motions of the arm about its desired position were more frequent and larger for the amputee as subject than they were for the author as subject. It must be emphasized, however, that the author had had considerable experience in the control of the arm. Because of the nature of the research effort involved for the author, it is impossible to make a fair estimate of an equivalent amount of training time for an amputee, but it probably exceeds 20 hours. The amputee, as mentioned earlier, had no more than two hours of training in the control of the arm. It is certain, however, from the experience in the case of the author as subject, that the accuracy of the control which a subject can exert over the arm operation does improve significantly with practice.

It was difficult to determine the reaction of the amputee to the emg-controlled elbow; it is very difficult for the author to make meaningful statements about the "feeling" of controlling the arm. One aspect of the present form of the system which interferes with a more detailed evaluation of the system is the fact that the arm is mounted to a rack of equipment rather than to the subject, and the tasks which can be posed the subject allow full concentration on the elbow motion. A more meaningful situation would have the arm mounted to a socket, and fitted to an amputee. His tasks would then include the simultaneous control of the elbow joint, his normal shoulder joint

(in order to position the arm), and the terminal device. Since the subject's control of all of these various aspects of the action are interrelated for any motion, the task would then be more realistic in the degree of mental concentration on the motion of the elbow joint which the subject was allowed. The ability of an amputee to lift objects and perform simple motor co-ordination tests in such a situation would be a good estimate of the capabilities of the overall system. It is our opinion, based on the limited evaluation which has been possible, that the capabilities of the emg-controlled elbow joint, which we have described above, are such as to indicate that the present system is a useful step toward an effective prosthesis.

## 7.2 MECHANICAL PORTION OF THE SYSTEM

For any given motor voltage, the flexion speed of the arm depends on its load. The arm can lift a weight of up to approximately ten pounds, very slowly, and its time to go from zero load through its complete angular range can be less than 0.75 sec.<sup>126</sup> These figures apply when there is very little external damping in the motor drive circuitry. In all of our operation, we have used external damping considerably in excess of that indicated above, in order to limit the peak flexion speeds to about one-half of that described above. It appeared even as early as the simulation studies that very rapid flexion capabilities of the prosthetic arm could exceed the subject's ability to correct for the small disturbances in the motion of the arm, and the over-all performance was thus degraded. An informal observation by this author is that, after many sessions of experience in operating the arm, it has been possible to decrease the damping, resulting in faster flexion speeds, with little or no degradation in performance.

The weight of the arm in its present form is slightly over two pounds, as compared with the weight of the arm of an average adult male of about three pounds. On the other hand, all of the drive train components, which account for most of the weight, are located in the forearm section, and the moment of inertia about the elbow joint is probably excessive. Rothchild suggests that for the distribution of weight in the present device, the total weight should not exceed about one and one-half pounds in order that an amputee be able to properly support and operate it. Thus certain weight reductions are necessary in the arm itself.

There is space in the forearm section around the motor and other drive components in which the necessary drive and signal processing electronics might be placed, if suitably miniaturized. It is our opinion that careful circuit design could result in an analog system, equivalent to the drive and processing electronics now comprising several racks of equipment and the computer in our realization of the system, which could be placed in that space. Both because of weight and size considerations, it is probably not advisable to attempt to include the batteries in this area; Rothchild's figures show that, in order to lift a five-pound load 360 times in a day (without recharging the batteries), approximately one pound of battery might be required. The efficiencies of the final control and processing circuitry would affect this figure, of course.

There appears to be a minimum flexion speed of which the arm is presently capable. By powering the arm externally this can be demonstrated to be due to frictional effects in the arm. Rothchild suggests the addition of velocity feedback in the motor control loop to compensate for this effect; we have not studied this possibility.

Under conditions of sufficient gain in the strain gauge loop, there is an oscillation of the arm position, when the subject is attempting to hold the arm position fixed. It appears that the short section above the elbow joint on the arm, whose function is to provide a suitable platform for mounting the arm to the socket, and on which the strain gauges are mounted, has unsatisfactory dynamic properties. The same type of oscillation can be stimulated at slightly lower strain gauge gains by lifting the arm up rapidly and then stopping; the discontinuity of effort appears to cause the oscillation in this case. Rothchild has suggested that this section be made stiffer.

When attempting to use the emg control to slowly lower the arm under load, there is a mode of operation in which the clutch is very noisy. The complete explanation for this is not known, although it seems to be a property of the clutch mechanism itself.

The terminal device (hook) which is presently mounted to the arm is not powered; there is at present no way to operate it except manually. Before the prosthesis can be fitted to an amputee and studies made of his ability to adequately control it in real situations, a control for the terminal device must be developed. Because of the fact that the muscles which previously controlled hand and wrist actions are not present in an above-elbow amputee, as mentioned in Sec. V, it is not possible to provide emg control for the terminal device in a normal manner. Emg control from other muscles, or conventional mechanical control of the terminal device, will be necessary for an above elbow amputee.

### 7.3 EMG SIGNAL PROCESSING

The signal processing now in use is equivalent to that shown in the block diagram in Fig. 15; the time constants of the two lowpass filters are equal, and are approximately 200 - 300 msec. For the author as subject, the time constants can be as short as 200 msec without noticeable degradation of control performance. For the amputee described above as subject, no value for the time constants was tried except the one value of 300 msec, and it is the author's judgement, from viewing the results, that a value of time constant less than 300 msec would not at this time be acceptable for this subject. Even with this longer time constant, the undesired motions of the arm, when controlled by this amputee, were both more frequent and larger than when the author was subject.

Early in the author's experience at operating the arm, a time constant of 300 msec was found to be necessary for his case also; however, over the course of the "training" which the author experienced, his ability to control the device seemed to improve. Thus at present, the faster response times in the arm motion, which result from the decreased time constant in the signal processing, can be adequately handled by the author. It is assumed that further experience on the part of the one amputee we investigated would



result in a similar improvement in his ability to control the arm with more rapid responses.

In addition to the difference between the time constants employed with the two subjects, noted above, there was of course an increased gain in the emg channels in the case of the amputee, to account for the decreased signal amplitude observed. Although a considerable range of adjustment of this gain should be allowed to accommodate the wide range of signal strengths to be expected from various subjects, it has been the experience of the author after many sessions of practice at operating the arm that the necessary gain did not vary significantly from day to day. Small variations in gain which might result from variations in electrode placement are apparently compensated for by the inherent visual feedback.

Between the output of the signal processing block diagram shown in Fig. 15, at the point at which the emg-generated signal is applied to the computation of the motor control signal, a "dead-zone", or "backlash generator" was tried in an attempt to decrease the frequency and amplitude of the undesired motions of the prosthesis. This was not found to improve the performance of the system. Bottomley shows emg data which he interprets as indicating that, not only should such a "backlash" scheme be included, but its "slack" should depend on the signal amplitude, in an approximately linear manner.<sup>22</sup> As explained in Sec. VI, we do not agree that the presence of "backlash" in the emg--force relation suggests the addition of more backlash in the signal processing "decoder". It is true that there are occasionally spurious, unintentional motions of the prosthesis, resulting from corresponding unintended variations in the emg signal. It is the experience of this author, however, that these decrease in frequency and amplitude with the amount of experience of the subject, and, most markedly, with the degree of concentration of the subject on his task of controlling the arm. Although a backlash system does tend to decrease these variations, it does so at the expense of the ability of the patient to exert fine control over the prosthesis: The small signals he intends for small modifications of the action of the system are themselves filtered out by the backlash generator, and he is thus obliged to produce wider variations in emg for small adjustments in prosthesis action.

On the other hand, it is admitted that a system is undesirable if its performance on everyday tasks (such as supporting a weight in a fixed position) demands excessive mental and visual concentration on the part of the user. Our tentative suggestions as to how the degree of concentration which is required might be reduced are outlined in the following section.

The effects of the curvature and multiple values in the emg--force relation (discussed in Sec. V) remain to be investigated. We have not observed any characteristic of the prosthesis action which seem related to these features. We assume that the effects of the multiple values and the curvature are likewise compensated for by the inherent visual feedback: The fact that the emg signal does not change exactly as intended, for example, becomes apparent to the subject through his observation that the

speed of the arm motion is not exactly that intended, and is corrected by a compensatory change in the muscular effort.

Bottomley has suggested the use of high-gain feedback around a portion of the signal processing network, in order to produce the effect of having the force exerted by the prosthesis under loaded conditions, or the velocity of the prosthesis under unloaded conditions, proportional to the integrated emg signal. The feedback from the strain gauges in our system is not intended to perform the function of causing some aspect of the action of the device to be proportional to the emg signal. Instead, this feedback is for the sole purpose of correcting for the abnormal mode of behavior introduced by the clutch, as discussed previously.

Our system design was initially motivated by the fact that, grossly speaking, there is a proportionality between the integrated emg and the force, under constant-velocity conditions. The resulting system, however, does not adhere strictly to that relation. It has been our experience that, as mentioned before, certain variations from that relationship in the system do not appear to seriously affect the over-all performance. It has been our assumption that this is due to the inherent visual feedback, and hence any improvement in this feedback to the patient would be expected to improve the subject's operation of the prosthesis. As a result, we have not concentrated on adjusting the characteristics of the arm or drive train in order to approach the proportionality relation more closely; we have instead accepted those characteristics as imposed by the arm itself.

We feel that the major shortcoming of the present signal processing is the fact that, at its output, there are small variations in the signal, which are not correlated with the variations in force being exerted by the subject. None of our attempts to improve this aspect of the signal processing, described previously, were successful. It has been suggested that the lowpass filter in the signal processing be changed to have some form other than one with an exponential impulse response. We have not attempted to study this possibility. General as our digital computer was as a signal processor, the realization of an impulse response which is not of exponential form is awkward, and would require considerable processing time, which was not available.

It is our impression that the goal of normal behavior of the prosthetic arm can best be approached through attaining feedback to the amputee outside of the visual channel. The addition of high-gain feedback around parts of the system not including the subject, can only serve to correct for anomalies in those parts of the system. Where the difficulty lies in variations in the signal generated, any feedback which is to be effective in decreasing these variations must include the subject in the feedback loop.

#### 7.4 FEEDBACK TO THE AMPUTEE

In its present form, the only means of feedback of prosthesis information to the amputee is through his visual observation of the arm performance. If the subject is distracted from his task of controlling the arm, then the performance of the system is degraded.

Conventional prostheses also rely on the visual feedback channel, but there are two other feedback paths to the subject. One is a reaction of the prosthesis force on the stump of the amputee. It is not clear exactly what information is received in this manner, but amputees do grow to depend on it through their experience. This aspect of feedback to the subject can be expected to be similar in the case of the emg-controlled elbow to that of the conventional prosthesis. However, the contribution of this feedback information to the operation of our prosthesis has not been evaluated because our prosthesis has not yet been fitted to an amputee.

The means of activating a conventional prosthesis provides also some inherent feedback which our prosthesis does not. In conventional prostheses, the movement of some part of the body is harnessed directly to the prosthesis action, and hence force and position information can be "felt" through the harness. In the case of our prosthesis, the control path utilizes a set of electrical contacts with the skin, and the contact is inherently one-way. Thus the feedback of information about prosthesis action to the amputee will probably be less with our emg-controlled device than that which conventional prostheses offer.

Although through the use of emg control it has been possible to provide control of the motor action of the prosthesis which is fairly close to that in a normal person, it is not possible at this time to provide normal sensation to an amputee. Many possible methods of feedback of sensory information to an amputee, which are all somewhat artificial in nature, have been suggested. For example, a tactile stimulation of the skin either through vibration, pressure, jets of air, etc., have been tried experimentally. Basically these all involve finding some means of transmitting information through the skin, and relying on the subject's ability to learn to associate the cutaneous sensation received with the proper sensation of prosthesis action.

It is the opinion of the author, based on both the information derived from the study of physiology, and on observation of the emg-controlled prosthesis, that the most important sensory information which is lacking from the present system, is the position information. It is this information which allows a normal person to hold his arm in a fixed position for an extended period without visual observation. This position information, if provided to the amputee in a satisfactory manner, might allow similar postural control of arm position to that in the normal. It would certainly make it possible for the amputee to perform some manipulations without the necessity that he visually concentrate on the prosthesis at each instant.

Considering the sensation of position information by the subject, there are two "systems" in the body to which this information should be provided: (1) the conscious system, so that the person can exert conscious control over the overall action being performed, and (2) the proprioceptive system, so that, through the normal postural regulation system, the emg signals sent to the muscles for correction of small variations about the desired motion can be sensed and used to provide the same corrections for the prosthesis position. To this end, we draw upon the experiment described in Sec. III in

which it was suggested that perhaps the muscle spindle signals do reach a conscious level. If this were true, then stimulation of the muscle spindles would be a means of providing both types of position feedback information through one feedback channel. Although we cannot be certain that such an approach can work, we believe it deserves study.

One possible method of stimulating the muscle spindles which occurred to us early, might be to use a small cineplastic tunnel, whose function is not to transmit muscular forces out of the body, but through which feedback signals could be transmitted back into the body. Upon further study, we concluded that such a technique had the same drawbacks as the conventional use of cineplasty (See Sec. 2.3). The next logical idea seemed to be to stimulate the muscle spindles externally, by pushing on the muscles. Although it may not actually have been the muscle spindles which were stimulated, it is certain that in our attempts to do so on the one subject described in Sec. III, he was able to derive sensory information from the stimulus being presented, which he could project as elbow position. Thus one of the most interesting, and probably by far the simplest, means of providing position information to an above-elbow amputee might be simply to devise a specialized socket construction for mounting the arm to the amputee, which pushed upwards on the biceps as the arm was raised, proportionally to the amount by which the elbow joint was moved from its extreme position. From the very limited consideration we have given to the feedback problem, we believe that the above suggestion is one which may approach the normal mode of feedback as closely as can be accomplished at this time.

## APPENDIX I

### Equipment Used in Attempts to Record Gross Nerve Potentials

In the first of the five experiments in which we attempted to record gross nerve potentials, the equipment used was as follows: Up to three channels of signal were recorded, on an Ampex FM Tape Recording System, at a tape speed of 60 inches per second. This provided a potential bandwidth from DC to 10 kcps. We chose such a high bandwidth because initially it was not clear that there was not significant information up to such high frequencies. The preamplifiers were three channels of a clinical electromyograph, a Disa Type 13A69. This device had an input impedance of 100 Megohms, and a bandwidth of approximately 2 cps. to 10 kcps. In order to properly match impedance levels, the outputs of these preamplifiers were each attenuated through resistive voltage dividers, which then drove Hewlett-Packard Model 450A Amplifiers, producing the proper 1.5 volt peak level required for the tape recorder system. The overall system had a bandwidth of approximately the bandwidth of the Disa equipment, 2 cps. to 10 kcps. The electrodes used were described in Sec. IV. A ground electrode was taped to the patient's shoulder, using electrode paste to assure a good electrical contact. This ground was connected to the ground point on the electromyograph, and from there to each piece of equipment at one point, and also to a water pipe.

A fourth channel on the magnetic tape was used to record a voice signal, which served to identify the various blocks of data, and, most importantly, to synchronize the signals observed to the commands given the patient.

The equipment used in each of the last four experiments was functionally the same as that described above, but consisted of totally different equipment. The preamplifiers were Grass Instrument Co. Model P-5 Physiological Preamplifiers, with high-impedance probes. These provided an input impedance of 2000 Megohms, push-pull. The signals were recorded directly on a Sanborn Model 2000 FM tape recording system, again at a tape speed of 60 inches per second. The two electrodes used for observation of each signal were connected to the differential inputs of the preamplifier probes. The output was used as a single-ended signal only. The over-all bandwidth could be adjusted to be as wide as approximately 0.1 cps. to 10 kcps, and was usually used in this position for recording of the nerve potentials. The noise observed at the output of the preamplifiers was equivalent to less than 10  $\mu$ v. at the input of the preamplifier. The nerve signals observed typically had peak amplitudes on the order of 100  $\mu$ v or more.

## APPENDIX II

### Method Used for Measuring Power Spectra of Bioelectric Signals

All of the signals for which the power spectra were desired were recorded in an FM mode on magnetic tape. In order to retain the original data in an intact form, the sections of tape that we desired to analyze were re-recorded on an Ampex Model 351 Tape Recording System, at a tape speed of 15 inches per second; the bandwidth of this recording was 30 cps to 15 kcps, and so it included the frequency band of interest. The resulting tape was cut and tape loops were formed, whose length each was approximately two seconds of signal. These loops were each played back repetitively, and each signal was analyzed by a General Radio Model 1554-A Sound and Vibration Analyzer. The Analyzer was preceded by a "pinking filter" whose system function falls at a constant rate of 6 db per octave over the band of interest. This serves, in effect, to convert the output of the analyzer from one of constant percentage bandwidth to one of constant absolute bandwidth. (With the pinking filter in place, a "white" noise, a signal with constant power per unit frequency band, does produce an output which is a constant level at all frequencies of interest.) The output of the Analyzer was automatically plotted on a General Radio Graphic Level Recorder Type 1521-A. The results were then transferred by hand to the Figures displayed in the text.

The sample length of two seconds is such that detail in the spectrum on the order of one cps wide or more could be observed. This is a fineness of spectral detail which considerably exceeds that of which the analyzer is capable in the frequency band of interest; thus the analysis procedure itself did not significantly distort the spectrum measured. Great care was taken to assure that the two-second section of the signal which was analyzed was actually representative of the complete signal of interest. Thus the spectral data displayed in the text is a fair measure of that observed for the conditions stated.

## Acknowledgment

Many have assisted the author by their guidance and suggestions. At the head of the list must be placed Professor Amar G. Bose, whose advice when it was needed most and stimuli when progress was slowest have contributed so much to this work. Dr. Melvin Glimcher and Dr. Thomas L. DeLorme, both of Massachusetts General Hospital, Harvard University Medical School, and the Rehabilitation Center of the Liberty Mutual Insurance Company, provided a wealth of medical experience and assistance, without which none of the experiments described in this report would never have been undertaken.

The readers of this thesis research have included Dr. L. W. Stark (now of the University of Chicago), Dr. M. H. Goldstein, Jr. (now of Johns Hopkins University), Prof. T. G. Stockham. Their assistance is gratefully acknowledged.

The work was undertaken at the Research Laboratory of Electronics of the Massachusetts Institute of Technology. Many personnel have assisted at one time or another and the author is grateful to all. The assistance of the staff of the PDP-1 Computer is especially acknowledged. The author wishes to thank the Research Laboratory of Electronics for the use of their facilities.

Financial support for this work was generously provided by the Liberty Mutual Insurance Company, for which the author is indebted.

## BIBLIOGRAPHY

1. Abbott, B. C., and Aubert, X., Changes of Energy in a Muscle During Slow Stretches, Proc. Royal Soc., B139, 104-117, 1951.
2. Abbott, B. C., Bigland, B., and Ritchie, J. M., The physiological cost of negative work, J. Physiol., 117, 380-390, 1952.
3. Abbott, B. C., and Bigland, B., The effects of force and speed changes on the rate of oxygen consumption during negative work, J. Physiol., 120, 319-325, 1953.
4. Adrian, E. D., Interpretation of the Electromyogram I, Lancet, June 13, 1925, 1229-1233.
5. Adrian, E. D., Interpretation of the Electromyogram II, Lancet, June 20, 1925, 1282-1286.
6. Adrian, E. D., and Bronk, D. W., The discharge of impulses in motor nerve fibres, J. Physiol., 67, 119-151, 1929.
7. Alderson, S. W., The Electric Arm, Chap. 13 in Human Limbs and Their Substitutes, ed. Klopsteg, P. E., and Wilson, P. D., McGraw-Hill, New York, 1954, 359-408.
8. Alderson, S. W., Electrical Energy Sources for Externally Powered Prosthetic and Orthopedic Devices, The application of External Power in Prosthetics and Orthotics, National Academy of Sciences--National Research Council Publication 874, 71-78, 1961.
9. Ashby, W. R., Design for a Brain, Wiley, 1952.
10. Atwood, J., Elkind, J., Houk, J., King, M., Stark, L., and Willis, P. A., Digital Computer Simulation of a neurological system, Quarterly Progress Report No. 63, Research Laboratory of Electronics, M. I. T., October 15, 1961, pp. 215-217.
11. Easmajian, J. V., Conscious Control of Single Nerve Cells, New Scientist, 20 (No. 369), 662-664, Dec. 12, 1963.
12. Battye, C. K., Nightingale, A., and Whillis, J., The use of myoelectric currents in the operation of prostheses, J. Bone, Jt. Surg., 37B, 506-510, 1955.
13. Beckman Instruments, Inc., Beckman Biopotential Skin Electrodes, Spinco Div., 1117 California Ave., Palo Alto, Calif. 94304.
14. Berger, W., and Huppert, C. R., The use of electrical and mechanical muscular forces for the control of an electrical prosthesis, Amer. J. Occupational Therapy, 6, No. 3, 110-114, May-June 1952.
15. Bergstrom, R. M., The relation between the number of impulses and the integrated electric activity in the EMG, Acta Physiol. Scand., 45, 97-101, March 31, 1959.
16. Bigland, B., Lippold, O.C.J., and Wrench, A. M., The electrical activity in isotonic contractions of human calf muscles, J. Physiol., 120, 40-41, 1953.
17. Bigland, B., and Lippold, O.C.J., The relation between force, velocity and integrated electrical activity in human muscles, J. Physiol., 123, 214-224, 1954.
18. Bigland, B., and Lippold, O.C.J., Motor unit activity in the voluntary contraction of human muscle, J. Physiol., 125, 322-325, 1959.
19. Billig, H. E., Van Harrevelde, A., and Wiersma, C.A.G., On the re-innervation of paretic muscles by use of their residual nerve, J. Neuropath. Exp. Neurol., 5, 1-23, 1946.
20. Borchardt, M. et al., eds., "Ersatzglieder und Arbeitshilfen", Springer, Berlin, 1919.
21. Bottomley, A. H., private communication.
22. Bottomley, A. H., and Cowell, T. K., An artificial hand controlled by the nerves, New Scientist, 21 (No. 382), 668-671, Mar. 12, 1964.



23. Braune, W., and Fischer, O., Rotationsmomente der beugemuskeln am Ellbogengelenk des Menschen, Abhandl. d. K. S. Ges. d. Wiss., 26, 242-310 and 5 tab., 1889.
24. Breydo, M. G., et al., A Bioelectric Control System, Problems of Cybernetics, No. 2, 203-212, Moscow, 1959 (in Russian). Translation available from U. S. Dept. of Commerce, Office of Technical Services; OTS 60-11, 255, JPRS 2240-N (Feb. 9, 1960).
25. Bronk, D. W., The energy expended in maintaining a muscular contraction, J. Physiol., 69, 306-315, 1930.
26. Brown, G. L., and Burns, B. D., Fatigue and neuromuscular block in mammalian skeletal muscle, Proc. Roy. Society, B136, 182-195, 1949.
27. Brown, J. E., A parametric study of neuroelectric responses to skin stimuli, Mass. Inst. of Tech. E. E. Thesis, Elec. Eng., 1960.
28. Brown, M. E., Long, C., and Weiss, G., Electromyographic Kinesiology of the hand, Part I, Method, Physical Therapy Review, 40, 453-458, 1960.
29. Buchthal, F., Problems of the pathologic physiology of poliomyelitis, Amer. J. Med., 6, 579-591, 1949.
30. Buchthal, F., The general concept of the motor unit, Neuromuscular Disorders, 34, Research Publication of the Association for Research in Nervous and Mental Disease, 3-30, 1961.
31. Buchthal, F., Guld, C., and Rosenfalck, P., Multielectrode study of the territory of a motor unit, Acta Physiol. Scand., B39, 83-104, 1957.
32. Buchthal, F., Guld, C., and Rosenfalck, P., Volume conduction of the spike of the motor unit potential investigated with a new type of multielectrode, Acta Physiol. Scand., A38, 331-354, 1957.
33. Buchthal, F., and Madsen, A., Synchronous activity in normal and atrophic muscle, EEG Clin. Neurophysiol., 2, 425-444, 1950.
34. Buchthal, F., et al., Motor unit territory in different human muscles, Acta Physiol. Scand., 45, 72-87, 1959.
35. Contini, R., Electromechanical Analogues in prosthetic systems, NEREM Record, 74-75, 197, 1962.
36. Davenport, W. B., and Root, W. L., An Introduction to the Theory of Random Signals and Noise, McGraw-Hill, New York, 1958, 103.
37. Dawson, G. D., and Scott, J. W., The recording of nerve action potentials through skin in man, J. Neurol., Neurosurg. Psychiat., 12, 259-267, 1949.
38. Denny-Brown, D., Interpretation of the EMG, Arch. Neurol. Psychiat. Chicago, 61, 99-128, 1949.
39. Digital Equipment Corp., Maynard, Mass., PDP-1 Handbook, Manual on the DEC PDP-1 Digital Computer.
40. Eccles, J. C., Eccles, R. M., Iggo, A., and Lundberg, A., Electrophysiological studies on gamma motoneurons, Acta Physiol. Scand., 50, 32-40, 1960.
41. Edwards, C., Changes in the discharge for a muscle spindle produced by electrotonus in the sensory nerve, J. Physiol., 127, 636-640, 1955.
42. Eldred, E., Granit, R., Holmgren, B., and Merton, P. A., Proprioceptive control of muscular contraction and the cerebellum, J. Physiol., 123, 46-47P, 1954.
43. Eldred, E., Granit, R., and Merton, P. A., Observations of "Intact", de-afferented and de-efferented muscle spindles, Acta Physiol. Scand., 29, 83-85, 1953.
44. Eldred, E., Granit, R., and Merton, P. A., Supraspinal control of the muscle spindles and its significance, J. Physiol., 122, 498-523, 1953.
45. Ermini, F., Buchthal, F., and Rosenfalck, P., Motor unit territory and muscle fiber concentration in paresis due to peripheral nerve injury and anterior horn cell involvement, Neurology, 9, No. 10, 657-671, 1959.

23. Braune, W., and Fischer, O., Rotationsmomente der beugemuskeln am Ellbogengelenk des Menschen, Abhandl. d. K. S. Ges. d. Wiss, 26, 242-310 and 5 tab., 1889.
24. Breydo, M. G., et al., A Bioelectric Control System, Problems of Cybernetics, No. 2, 203-212, Moscow, 1959 (in Russian). Translation available from U. S. Dep of Commerce, Office of Technical Services; OTS 60-11, 255, JPRS 2240-N (Feb. 9, 1960).
25. Bronk, D. W., The energy expended in maintaining a muscular contraction, J. Physiol., 69, 306-315, 1930.
26. Brown, G. L., and Burns, B. D., Fatigue and neuromuscular block in mammalian skeletal muscle, Proc. Roy. Society, B136, 182-195, 1949.
27. Brown, J. E., A parametric study of neuroelectric responses to skin stimuli, Mass. Inst. of Tech. E. E. Thesis, Elec. Eng., 1960.
28. Brown, M. E., Long, C., and Weiss, G., Electromyographic Kinesiology of the hand Part I, Method, Physical Therapy Review, 40, 453-458, 1960.
29. Buchthal, F., Problems of the pathologic physiology of poliomyelitis, Amer. J. Med., 5, 579-591, 1949.
30. Buchthal, F., The general concept of the motor unit, Neuromuscular Disorders, 34, Research Publication of the Association for Research in Nervous and Mental Disease, 3-30, 1961.
31. Buchthal, F., Guld, C., and Rosenfalck, P., Multielectrode study of the territory of a motor unit, Acta Physiol. Scand., B39, 83-104, 1957.
32. Buchthal, F., Guld, C., and Rosenfalck, P., Volume conduction of the spike of a motor unit potential investigated with a new type of multielectrode, Acta Physiol. Scand., A38, 331-354, 1957.
33. Buchthal, F., and Madsen, A., Synchronous activity in normal and atrophic muscles, EEG Clin. Neurophysiol., 2, 425-444, 1950.
34. Buchthal, F., et al., Motor unit territory in different human muscles, Acta Physiol. Scand., 45, 72-87, 1959.
35. Contini, R., Electromechanical Analogues in prosthetic systems, NEREM Record, 74-75, 197, 1962.
36. Davenport, W. B., and Root, W. L., An Introduction to the Theory of Random Signals and Noise, McGraw-Hill, New York, 1958, 103.
37. Dawson, G. D., and Scott, J. W., The recording of nerve action potentials through skin in man, J. Neurol., Neurosurg. Psychiat., 12, 259-267, 1949.
38. Denny-Brown, D., Interpretation of the EMG, Arch. Neurol. Psychiat. Chicago, 61, 99-128, 1949.
39. Digital Equipment Corp., Maynard, Mass., PDP-1 Handbook, Manual on the DEC PDP-1 Digital Computer.
40. Eccles, J. C., Eccles, R. M., Iggo, A., and Lundberg, A., Electrophysiological studies on gamma motoneurons, Acta Physiol. Scand., 50, 32-40, 1960.
41. Edwards, C., Changes in the discharge for a muscle spindle produced by electrotonus in the sensory nerve, J. Physiol., 127, 636-640, 1955.
42. Eldred, E., Granit, R., Holmgren, B., and Merton, P. A., Proprioceptive control of muscular contraction and the cerebellum, J. Physiol., 123, 46-47P, 1954.
43. Eldred, E., Granit, R., and Merton, P. A., Observations of "Intact", de-afferented and de-efferented muscle spindles, Acta Physiol. Scand., 29, 83-85, 1953.
44. Eldred, E., Granit, R., and Merton, P. A., Supraspinal control of the muscle spindles and its significance, J. Physiol., 122, 498-523, 1953.
45. Ermini, F., Buchthal, F., and Rosenfalck, P., Motor unit territory and muscle fiber concentration in paresis due to peripheral nerve injury and anterior horn cell involvement, Neurology, 9, No. 10, 657-671, 1959.

46. Ernst, H. A., A computer-operated mechanical hand, Mass. Inst. of Tech., Sc.D. Thesis, Elec. Eng., Dec. 1961.
47. Fenn, W. O., and Marsh, B. S., Muscular force at different speeds of shortening, *J. Physiol.*, 85, 277-297, 1935.
48. Fischer, E., Physiology of skeletal muscle, Chapter 3 in Electrodiagnosis and Electromyography, ed. Licht, S., Waverly Press, Baltimore, Md., 1961, 66-112.
49. Furman, B., Progress in prosthetics, U. S. Dept. of Health, Education, and Welfare, Office of Vocational Rehabilitation, available from Supt. of Documents, U. S. Government Printing Office, 1962.
50. Ibid., p. 1.
51. Furman, G. G., Neuro muscular control: possible subject for bionic study, Univ. of Calif. (Berkeley) Electronics Research Laboratory, Inst. of Eng. Research Series No. 60, Issue No. 393, AFOSR 1750, 1961.
52. Gardner, E., Fundamentals of Neurology, 3rd ed., W. B. Saunders Co., 1958.
53. Geddes, L. A., Moore, A. C., Spencer, W. A., and Hoff, H. E., Electropneumatic control of the McKibben synthetic muscle, *Orthopaedic and Prosthetic Appliance J.*, 13, 33-36, 1959.
54. Glimcher, M., private communication.
55. Goldstein, M. H. Jr., and Kiang, N. Y-S, Synchrony of neural activity in electric responses evoked by transient acoustic stimuli, *J. Acoust. Soc. Am.*, 30, No. 2, 107-114, Feb. 1958.
56. Granit, R., Neuromuscular interaction in postsutural tone of the cat's isometric soleus muscle, *J. Physiol.*, 143, 387-402, 1958.
57. Granit, R., Receptors and Sensory Perception, Yale Univ. Press, New Haven, Conn., 1955.
58. Granit, R., Holmgren, B., Merton, P. A., The two routes for excitation of muscle and their subservience to the cerebellum, *J. Physiol.*, 130, 213-224, 1955.
59. Granit, R., and Kaada, B. R., The influence of stimulation of central nervous structures on muscle spindles in the cat, *Acta Physiol. Scand.*, 27, 130-160, 1952.
60. Gwynne, G. E., Kinesiology of elbow flexion, Univ. of Calif. (L.A.) Biol. Lab. Prog. Rpt., Dec. 15, 1960, 10-20.
61. Hall, M. J., private communication.
62. Hammond, P. H., An experimental study of servo action in human muscular control, Third International Conference on Medical Electronics, July 22, 1960.
63. Hammond, P. H., Merton, P. A., and Sutton, G. G., Nervous gradation of muscular contraction, *British Medical Bulletin*, 13, No. 3, 214-218, 1956.
64. Hayes, K. J., Wave analysis of tissue noise and muscle action potentials, *J. Appl. Physiol.*, 15, 749-752, 1960.
65. Hill, A. V., The heat of shortening and the dynamic constants of muscle, *Proc. Royal Soc. (London)*, B126, 136, 1936.
66. Hill, A. V., The abrupt transition from rest to activity in muscle, *Proc. Royal Soc.*, B136, 399-420, 1949.
67. Hill, A. V., A discussion on muscular contraction and relaxation: their physical and chemical basis, *Proc. Roy. Soc. (London)*, B137, 40, 1950.
68. Hill, A. V., The mechanics of voluntary muscle, *Lancet*, 947-951, Nov. 24, 1951.
69. Hodgkin, A. L., Huxley, A. F., and Katz, B., Measurement of current-voltage relations in the membrane of the giant axon of Loligo, *J. Physiol.*, 116, 424-448, 1952.

70. Hodgkin, A. L., and Huxley, A. F., Currents carried by sodium and potassium ions through the membrane of the giant squid axon of Loligo, J. Physiol., 116, 449-496, 1952.
71. Hodgkin, A. L., and Huxley, A. F., The components of membrane conductance in the giant axon of Loligo, J. Physiol., 116, 473-496, 1952.
72. Hodgkin, A. L., and Huxley, A. F., The dual effect of membrane potential on membrane conductance in the giant axon of Loligo, J. Physiol., 116, 497-506, 1952.
73. Hodgkin, A. L., and Huxley, A. F., A quantitative description of membrane current and its application to conduction and excitation in nerve, J. Physiol., 117, 500-551, 1952.
74. Hofer, P.F.A., and Putnam, J. J., Action potentials of muscles in normal subjects, Arch. Neurol. Psychiat. Chicago, 42, 201-218, 1939.
75. Holmgren, B., and Merton, P.A., Local feedback control of motoneurons, J. Physiol., 123, 47-48, 1954.
76. Houk, J., Okabe, Y., Rhodes, H. E., Stark, L., and Willis, P., Transient responses of human motor coordination system, Quarterly Progress Report No. 64, Research Laboratory of Electronics, M.I.T., January 15, 1962, pp. 315-326.
77. Houk, J. C., and Stark, L., An analytical model of a muscle spindle receptor for simulation of motor coordination, Quarterly Progress Report No. 66, Research Laboratory of Electronics, M.I.T., July 15, 1962, pp. 384-389.
78. Hubbard, S. J., A study of rapid mechanical events in a mechano-receptor, J. Physiol., 141, 198-218, 1958.
79. Hunt, C. C., The reflex activity of mammalian small-nerve fibres, J. Physiol., 115, 456-469, 1951.
80. Inman, V., Ralston, P., Saunders, I., Feinstein, A., Wright, Relation of human electromyogram to muscular tension, EEG and Clin. Neurophysiol., 4, 187-193, 1952.
81. International Business Machines Corp., Endicott, N. Y., Research and Development of Arms and Hands by Electrical, Hydraulic, and Pneumatic Methods; Development of Nylon Hands; Arm and Hand Motion Studies. Subcontractor's final report to the National Research Council Committee on Artificial Limbs, covering the period June 1945 through June 1947.
82. Kats, B., The relation between force and speed in muscular contraction, J. Physiol., 96, 45, 1939.
83. Kats, B., Depolarization of sensory terminals and the initiation of impulses in the muscle spindle, J. Physiol., 111, 261-282, 1959.
84. Kay, W. N., and Peiser, E., Studies of the upper-extremity amputee, Artificial Limbs, 5, 32, August, 1958.
85. Kiessling, E. A., Pneumatic prosthetic components; Rigid servo mechanisms and their functional control valves. Report on the conference held at Lake Arrowhead, Calif., Sept. 1960. Available from Printing and Publishing Office, National Academy of Sciences--National Research Council, Washington 25, D.C., 116-131.
86. Klijn, J. A., Some new data on electromyography, Acta Physiol. Pharmacol. Neerlandica, 2, 82-96, 1960.
87. Klopsteg, P. E., and Wilson, P. D., Human Limbs and their Substitutes, McGraw Hill, N. Y., 1954.
88. Ibid., Chapter 3, 48-78.
89. Ko, W. H., Thompson, W., and Yon, E., Tunnel diode transmitter for medical applications and laboratory telemetering, Proc. 1962 International Solid State Circuits Conference.

90. Kobrinsky, A. E., Use of biocurrents for control purposes, *Izvestia AN USSR, OTN, EIA*, No. 3, 150-154, 1959, (in Russian). Translation AFCRC-TN-60-354, AF19(604)-5970 (1960), available from Air Force Cambridge Research Center, Bedford, Mass.
91. Kobrinsky, A. E., Bioelectric control systems, *Radio*, No. 11, 37-39, 1960, (in Russian). Translation available from ASTIA, AD-276 927.
92. Kobrinsky, A. E., Bioelectric control of prosthetic devices, *Herald of the Academy of Sciences USSR*, 30, No. 7, Moscow, 58-61, July 1960, (in Russian). Translation JPRS 7075, Nov. 18, 1960, available from Office of Technical Services, U. S. Dept. of Commerce, Washington 25, D. C.
93. Kobrinsky, A. E., et al., Problems of bioelectric control, Proc. 2 of the International Federation of Automatic Control Conference, Moscow, 1960, 1119-1122, available from Butterworths Scientific Publications, London, 1960.
94. Kotel'Nikova, E. G., and Zakhar'iants, IuZ., A method for a complex EMG and biomedical analysis of muscle work, *Sech. Physiol. J. USSR*, 46, 877-880, July 1960.
95. Kuck, A., Liebman, F. M., and Kussick, L., A miniature transmitter for telemetering muscle potentials, *IRE Trans. Biomedical Elec.*, July 1963, 117-119.
96. Lenman, J.A.R., Quantitative electromyographic changes associated with muscular weakness, *J. Neurol. Neurosurg., Psychiat.*, 22, 306-310, 1959.
97. Licht, S., Electrodiagnosis and Electromyography, Waverly Press, Baltimore, Md., 1961.
98. Lindsley, D., Electrical activity of human motor units during voluntary contraction, *Amer. J. Physiol.*, 114, 90-99, 1935.
99. Lippold, O., The relation between integrated action potentials in a human muscle and its isometric tension, *J. Physiol.*, 117, 492-499, 1952.
100. Lippold, O., Redfearn, J., and Vuco, J., The effect of sinusoidal stretching upon the activity of stretch receptors in voluntary muscle and their reflex responses, *J. Physiol.*, 144, 373-386, 1958.
101. Lippold, O., Nichols, and Redfearn, J., Electrical and mechanical factors in the adaptation of a mammalian muscle spindle, *J. Physiol.*, 153, 209-217, 1960.
102. Loewenstein, W. R., Excitation and changes in adaptation by stretch of mechanoreceptors, *J. Physiol.* 133, 588-602, 1956.
103. Long, C., Brown, M. E., Weiss, G., An EMG study of the extrinsic-intrinsic kinesiology of the hand; Prelim. Rpt., *Arch. Phys. Med. and Reh.*, 41, 175-181, May 1960.
104. Long, C., Brown, M. E., Weiss, G., EMG Kinesiology of the hand: Part II. Third dorsal interosseous and extensor digitorum of the long finger, *Arch. Phys. Med.*, 42, 559-565, Aug. 1961.
105. Marquardt, E., and Hafner, O., Technical adequacy and practical application of the Heidelberg pneumatic prosthesis, *World Veterans Federation Rehabilitation Bulletin* No. 15, 11-24. Also *Archiv. fur Orthopaedische und Unfall-Chirurgie*, 48, 1-5, (in German). Translation available from International Society for the Welfare of Cripples, 701 First Ave., New York 17, N.Y.
106. Mason, S. J., and Zimmermann, H. J., Electronic Circuits, Signals, and Systems, Wiley, 1960, p. 281.
107. Matthews, B.H.C., The response of a single end organ, *J. Physiol.*, 71, 64-110, 1931.
108. Matthews, B.H.C., Nerve endings in mammalian muscle, *J. Physiol.*, 78, 1-53, 1933.
109. Merton, P. A., Speculations on the servo-control of movement, *CIBA Symposium, The Spinal Cord*, 247-260, 1953.

110. Mikyska, A., Simultaneous registration on magnetic tape of pulse frequency and EMG data in physiological studies, *Sech. Phys. J. USSR*, 47, 524, April 1961.
111. Miner, N., Integumental specification of sensory fibers in the development of cutaneous local sign, *J. Comp. Neurol.*, 105, 161-170, 1956.
112. National Academy of Sciences-National Research Council, The application of external power in prosthetics and orthotics, Report on the conference held at Lake Arrowhead, Calif., Sept. 22-25, 1960. Available from Printing and Publishing Office, National Academy of Sciences--National Research Council, Washington, D.C., Publication #
113. Nightingale, A., Background noise in electromyography, *Phys. Med. Biol.*, 3, 325-338, 1959.
114. Nightingale, A., The graphic representation of movement. II. Relationship between muscle force and the electromyogram in the stand-at-ease position, *Ann. Phys. Med.*, 5, 187-191, 1960.
115. Northrop Aircraft, Inc., Hawthorne, Calif., Subcontractor's final report to the NRC Committee on Artificial Limbs, A Report on Prosthesis Development covering the period Jan. 2, 1945 to July 1, 1947.
116. Okabe, Y., Rhodes, H. E., Stark, L., Willis, P. A., Transient responses of human motor coordination system, Quarterly Progress Report No. 66, Research Laboratory of Electronics, M. I. T., July 15, 1962, pp. 389-395.
117. Okabe, Y., Rhodes, H. E., Stark, L., Willis, P. A., Simultaneous hand and eye tracking movements, QPR No. 66, R. L. E., M. I. T., July 15, 1962, pp. 395-401.
118. Patton, H. D., Special properties of nerve trunks and tracts, Chapter 3, 66-95, in Ruch, T. C., and Fulton, J. F., Medical Physiology and Biophysics, W. B. Saunders Co., 1960.
119. Patton, H. D., Spinal reflexes and synaptic transmission, Chapter 5, 130-166, in Ruch, T. C., and Fulton, J. F., Medical Physiology and Biophysics, W. B. Saunders Co., 1960.
120. Patton, H. D., Reflex regulation of movement and posture, Chapter 6, 167-205, in Ruch, T. C., and Fulton, J. F., Medical Physiology and Biophysics, W. B. Saunders Co., 1960.
121. Pierce, D. S., and Wagman, I. H., A method of recording from single muscle fibers or motor units in human skeletal muscle, *J. Appl. Physiol.*, 19, No. 2, 366-368, March 1964.
122. Pinelli, P., and Buchthal, F., Duration, amplitude and shape of muscle action potentials in poliomyelitis, *EEG Clin. Neurophysiol.*, 3, 497-504, 1951.
123. Ralston, H. J., Uses and limitations of electromyography in the quantitative study of skeletal muscle function, *Amer. J. Orthodontics*, 47, 521-530, 1961.
124. Ralston, H. J., Inman, V. T., Strait, L. A., and Shaffrath, M. C., Mechanics of human isolated voluntary muscle, *Amer. J. Physiol.*, 151, 612-620, 1947.
125. Reswick, J. B., et al., Conscious control of programmed motions in orthotics and prosthetics, Case Inst. of Tech., Medical Eng. Report No. EDC 4-62-2, Aug. 1961.
126. Rothchild, R., Design of an externally powered artificial elbow for electromyogram control, Mass. Inst. of Tech., Dept. of Mech. Eng., S. M. Thesis, May 21, 1965.
127. Scott, R. N., Processing the EMG signal, Report of the Conference on the Control of External Power in Upper-Extremity Rehabilitation, Airlie House, Warrenton, Va., April 8-10, 1965 (in press).
128. Smith, O. C., Action potentials from single motor units in voluntary contraction, *Amer. J. Physiol.*, 108, 629-638, 1934.
129. Smith, O. J. M., Nonlinear computations in the human controller, *IRE PGBME*, April 1962, 125-128.

130. Sperry, C., Gadsden, G., Rodriguez, C., and Bach, L., Miniature subcutaneous FM transmitter for brain potentials, *Science*, 134, 1423, Nov. 1961.
131. Stark, L., Neurological organization of the control system for movement, *Quarterly Progress Report No. 61*, Research Laboratory of Electronics, M. I. T., April 15, 1961, pp. 234-238.
132. Stark, L. W., personal communication.
133. Stark, L., Houk, J., Willis, P. A., and Elkind, J., The dynamic characteristics of a muscle model used in digital computer simulation of an agonist-antagonist muscle system in man, *Quarterly Progress Report No. 64*, Research Laboratory of Electronics, M. I. T., January 15, 1962, pp. 309-315.
134. Taylor, C. L., The biomechanics of the normal and of the amputated upper extremity, Chapter 7 in Klopsteg, P. E., and Wilson, P. D., Human Limbs and Their Substitutes, (McGraw-Hill, New York, 1954), pp. 169-221.
135. Ibid., p. 217.
136. Tomovic, R., Human hand as a feedback system, Proc. I., IFAC Congress, Moscow, 1960, in Butterworths Scientific Publications, London, 1961, pp. 31-35.
137. Tomovic, R., Artificial hand responds to touch, *Electronics*, pp. 76-82, May 18, 1962.
138. Tomovic, R., and Boni, G., An adaptive artificial hand, IRE PGAC, April 1962, pp. 3-10.
139. Van Harreveld, A., Reinnervation of denervated muscle fibres by adjacent functioning motor units, *Amer. J. Physiol.*, 144, 477-493, 1945.
140. Waggott, J. B., personal communication.
141. Wagman, I. H., and Pierce, D. S., Some electrical properties of the neuromuscular system, Report of the Conference on the Control of External Power in Upper-Extremity Rehabilitation, Airlie House, Warrenton, Va., April 8-10, 1965, National Academy of Sciences, National Research Council Publication 1352, pp. 35-44, 1966.
142. Waring, W., and Nickel, V. L., Investigation of myoelectric control of functional braces, Final Report on Planning Grant RD-1655-M-64, from Vocational Rehabilitation Administration, Dept. of Health, Education and Welfare, to Attending Staff Association, Rancho Los Amigos Hospital, Downey, Calif., March 1965.
143. Weiss, P., and Edds, M. V. Jr., Spontaneous recovery of muscle following partial denervation, *Amer. J. Physiol.*, 145, 587-607, 1945-1946.
144. Weltman, G., Groth, H., and Lyman, J., An analysis of bioelectrical prosthesis control, Univ. of Calif. (L. A.) Bio-Technology Lab. Tech. Report No. 1, July 1959.
145. Weltman, G., and Lyman, J., The effects of electronic transformations on the pattern of myoelectric activity during arm movement, Univ. of Calif. (L. A.) Biotechnology Lab. Tech. Rpt. No. 6, Sept. 1960.
146. Wiersma, C. A. G., Muscles consisting of a single motor unit after poliomyelitis *Proc. Soc. Exper. Biol. Med.*, 61, 85-89, 1946.
147. Wilkie, D. R., The relation between force and velocity in human muscle, *J. Physiol.*, 110, 249-280, 1950.
148. Willis, D. G., Plastic neurons as memory elements, International Conference on Information Processing, N. Y., 1960. In Proceedings, available from Unesco Publications Ctr., N. Y.
149. Wilson, A. B., The Hendon pneumatic prosthesis motor, *Brit. Med. J.*, 227, July 16, 1960.
150. Woodbury, J. W., and Patton, H. D., Action potential; cable and excitable properties of the cell membrane, Chapter 2, 32-65, in Ruch, T. C., and Fulton, J. F., Medical Physiology and Biophysics, W. B. Saunders Co., 1960.

151. Woodbury, J. W., and Ruch, T., Muscle, Chapter 4, 96-127, in Ruch, T. C., and Fulton, J. F., Medical Physiology and Biophysics. W. B. Saunders Co., 1960.
152. Yon, E., A study of R.F. power supply for implanted transmitters, Report No. EDC 3-62-1, Solid State Electronics Laboratory, Case Institute of Technology, May 1962.
153. Young, L. R., and Stark, L., A sampled-data model for eye-tracking movements, Quarterly Progress Report No. 66, Research Laboratory of Electronics, M. I. T., July 15, 1962, pp. 370-384.
154. Zhukov, E. K., and Zakhar'iants, Iu. Z., Synchronized rhythm of action potentials during muscular activity in man, Sechenov Physiol. J. (U. S. S. R.) 45, 1053-1059 (September 1959).
155. Bliss, J. C., and Crane, H. D., Quantitative tactile experiments with dynamic spatial patterns, Report of the Conference on the Control of External Power in Upper-Extremity Rehabilitation, Airlie House, Warrenton, Va., April 8-10, 1965, National Academy of Sciences, National Research Council Publication 1352, pp. 255-261, 1966.
156. Hahn, J. F., Summary report on communication via the skin, The Application of External Power in Prosthesis and Orthotics, National Academy of Sciences, National Research Council Publication 874, pp. 145-149, 1961.



UNCLASSIFIED

Security Classification

DOCUMENT CONTROL DATA - R & D		
<i>(Security classification of title, body of abstract and indexing annotation must be entered when the overall report is classified)</i>		
1. ORIGINATING ACTIVITY (Corporate author) Research Laboratory of Electronics Massachusetts Institute of Technology Cambridge, Massachusetts	2a. REPORT SECURITY CLASSIFICATION Unclassified	2b. GROUP None
3. REPORT TITLE Bioelectric Control of Prostheses		
4. DESCRIPTIVE NOTES (Type of report and, inclusive dates) Technical Report		
5. AUTHOR(S) (First name, middle initial, last name) Ralph Alter		
6. REPORT DATE December 1, 1966	7a. TOTAL NO. OF PAGES 100	7b. NO. OF REFS 156
8a. CONTRACT OR GRANT NO. DA 36-039-AMC-03200(E) b. PROJECT NO 200-14501-B31F c. d.	9a. ORIGINATOR'S REPORT NUMBER(S) Technical Report <del>445</del> 446 9b. OTHER REPORT NO(S) (Any other numbers that may be assigned this report)	
10. DISTRIBUTION STATEMENT Distribution of this report is unlimited		
11. SUPPLEMENTARY NOTES	12. SPONSORING MILITARY ACTIVITY Joint Services Electronics Program thru USAECOM, Fort Monmouth, N. J.	
13. <del>ABSTRACT</del> Externally powered prostheses have been studied for many years, to provide more effective rehabilitation of amputees. To take advantage of the benefits offered by external power in prostheses, however, the mode of control of the prosthesis by the amputee must be improved. Conventional control methods require a high degree of mental concentration by the amputee on his prosthesis, because of at least two important factors: (i) the mode of control of a prosthesis motion is different from control of the corresponding normal action; (ii) there is no feedback of sensation from the prosthesis to the patient except through the visual sense. Our system utilizes surface electromyographic (emg) signals from the biceps and triceps of an amputee's arm to provide graded control of an elbow prosthesis. Included as an intermediate step is the control of a simulated forearm in a digital computer, in real time. At present, the signal processing consists of full-wave rectification and lowpass filtering of the emg signals from biceps and triceps muscles; mechanical elbow prosthesis can now be voluntarily controlled through the subject's emg signals. The performance of the system and indications for future work are outlined. Foremost is the need for feedback to the patient of position information from the prosthesis, outside of the visual sense. A possible method for accomplishing this in an inherently normal manner is suggested. The use of nerve signals as the control signal for a prosthesis offers potential advantages over the use of the emg signal; the practical problems in observing nerve signals, combined with lack of information on how to interpret them, makes this approach infeasible now. Preliminary experiments for deriving the information so that nerve signals can be used are described. Results are still inclusive.		

DD FORM 1 NOV 65 1473 (PAGE 1)  
S/N 0101-807-6811

UNCLASSIFIED  
Security Classification

A-31408

**UNCLASSIFIED**

Security Classification

14 KEY WORDS	LINK A		LINK B		LINK C	
	ROLE	WT	ROLE	WT	ROLE	WT
Amputee rehabilitation Prostheses, externally powered Prosthesis motion, mode of control Electromyographic signal control Simulated forearm, signal processing Nerve-signal control, present infeasibility Prostheses, bioelectric control						

DD FORM 1 NOV 68 **1473** (BACK)  
S/N 0101-807-6821

**UNCLASSIFIED**

Security Classification

A-314