

AEDC-TR-66-228



**RECENT DEVELOPMENTS IN
HEAT-TRANSFER-RATE, PRESSURE,
AND FORCE MEASUREMENTS FOR HOTSHOT TUNNELS**

**R. L. Ledford, W. E. Smotherman, and C. T. Kidd
ARO, Inc.**

January 1967

Distribution of this document is unlimited.

**VON KÁRMÁN GAS DYNAMICS FACILITY
ARNOLD ENGINEERING DEVELOPMENT CENTER
AIR FORCE SYSTEMS COMMAND
ARNOLD AIR FORCE STATION, TENNESSEE**

NOTICES

When U. S. Government drawings specifications, or other data are used for any purpose other than a definitely related Government procurement operation, the Government thereby incurs no responsibility nor any obligation whatsoever, and the fact that the Government may have formulated, furnished, or in any way supplied the said drawings, specifications, or other data, is not to be regarded by implication or otherwise, or in any manner licensing the holder or any other person or corporation, or conveying any rights or permission to manufacture, use, or sell any patented invention that may in any way be related thereto.

Qualified users may obtain copies of this report from the Defense Documentation Center.

References to named commercial products in this report are not to be considered in any sense as an endorsement of the product by the United States Air Force or the Government.

RECENT DEVELOPMENTS IN
HEAT-TRANSFER-RATE, PRESSURE,
AND FORCE MEASUREMENTS FOR HOTSHOT TUNNELS

R. L. Ledford, W. E. Smotherman, and C. T. Kidd
ARO, Inc.

Distribution of this document is unlimited.

FOREWORD

The work reported herein was sponsored by Headquarters, Arnold Engineering Development Center (AEDC), Air Force Systems Command (AFSC), under Program Element 65402234.

The research and development were done by ARO, Inc. (a subsidiary of Sverdrup & Parcel and Associates, Inc.), contract operator of the AEDC, AFSC, Arnold Air Force Station, Tennessee, under Contract AF 40(600)-1200. Applicable ARO Project Numbers are VW2920, VW2983, and VT3503, and the manuscript was submitted for publication on October 20, 1966.

This report was presented at the 2nd International Congress on Instrumentation in Aerospace Simulation Facilities sponsored by the Institute of Electronic and Electrical Engineers.

This technical report has been reviewed and is approved.

Marshall Kingery
Technical Facility
Development Division
Directorate of Plans and Technology

Edward R. Feicht
Colonel, USAF
Director of Plans and Technology

ABSTRACT

Heat-transfer rate, pressure, and force are essential parameters which must be measured in the operation of a hotshot wind tunnel. Transducers of the proper size, range, and time reponse required for making these measurements are not generally available on a commercial basis. Therefore, developmental programs directed towards satisfaction of these measurement requirements were undertaken at the AEDC. As a result of these programs, transducers were developed which enabled these measurements to be made. Recent developments have resulted in measurement capabilities and accuracies which are superior to those of transducers which were developed early in these programs (about 1960). A description of these improved transducers and their performance characteristics are contained herein.

CONTENTS

	<u>Page</u>
ABSTRACT	iii
NOMENCLATURE	vi
I. INTRODUCTION	1
II. HEAT-TRANSFER-RATE MEASUREMENT.	1
III. PRESSURE MEASUREMENTS.	8
IV. FORCE MEASUREMENTS	13
V. CONCLUSIONS	20
REFERENCES.	23

ILLUSTRATIONS

Figure

1. Cross Section of Calorimeter-Type Heat-Transfer-Rate Transducer with Thin-Film Resistance Thermometer Temperature Sensor (RT Gage).	3
2. Heat-Transfer-Rate Transducer (RT Gage) Time Response	4
3. Heat-Transfer-Rate Transducer Instrumentation System	5
4. Heat-Transfer-Rate and Pressure Oscillogram	7
5. Variable Reluctance Wafer Pressure Transducer	8
6. Semiconductor Wafer Gage Assembly	9
7. Pressure Transducer Instrumentation System	12
8. Six-Component Balance Load Cell Positions	14
9. Six-Component Balance Cross Section	15
10. Six-Component Balance Assembly	16
11. Balance Components	17
12. Block Diagram of Instrumentation Required for Measurement of One Component of Force	19
13. Six-Component Force Balance Oscillogram	22

TABLES

	<u>Page</u>
I. Semiconductor Wafer and Variable Reluctance Wafer Pressure Transducer Specifications	11
II. Six-Component Force Balance Interaction Matrix	21

NOMENCLATURE

c_p	Specific heat, Btu/lb - °F
E	Excitation voltage, v
E_o	Output signal voltage, v
K_1, K_2	Constants
k	Thermal diffusivity, in. ² /sec
l	Disk thickness, in.
\dot{q}	Heat-transfer rate, Btu/ft ² - sec
R_1, R_2, R_3	Resistance, ohms
R_o	Initial resistance, ohms
R_T	Resistance at temperature T, ohms
T	Temperature, °F
t	Time, sec
α	Thermal coefficient of resistance, $\Omega/\Omega/^\circ\text{F}$
ρ	Density, lb/in. ³
Ω	Ohm

SECTION I INTRODUCTION

Continuous efforts are made at the Arnold Engineering Development Center (AEDC) to improve techniques for the measurement of heat-transfer rates, pressures, and forces in the hotshot tunnels of the von Kármán Gas Dynamics Facility (VKF). Significant advances have recently been made in each of these measurement areas. A calorimeter-type heat-transfer-rate transducer which utilizes a thin-film resistance thermometer sensor has been developed which provides a large increase in sensitivity over thermocouple-type sensors previously used. Miniature pressure transducers which employ semiconductor strain gages have been developed for model pressure measurements. These transducers can operate over a much wider measurement range (≈ 0.05 to 15 psid) than variable reluctance models and also require far less maintenance. A six-component force balance which employs semiconductor strain gages for instrumentation of its load cells and accelerometers has been developed. This balance has a greater sensitivity and lower interactions than others which have been used. Accelerometers which can compensate for the effects of inertial forces produced by vibration of the model-support system are an integral part of the balance. A description of each of these devices, all of which have been used satisfactorily in tunnel tests, will be presented in this report.

The hotshot tunnel (Ref. 1) (Tunnel F) in which these transducers are used has a 100-in. -diam test section, and the run times vary from 50 to 100 msec. Instrumentation used with these transducers consists of a carrier amplifier-demodulator system which provides a regulated 5-v, 20-kc source for transducer excitation and has a maximum voltage gain of 2500. Data are recorded with light-beam galvanometer-type oscillographs and with a high speed analog-to-digital system which provides a data format acceptable for an electronic computer.

SECTION II HEAT-TRANSFER-RATE MEASUREMENT

For the past five years, model heat-transfer-rate measurements in the AEDC hypervelocity facilities have been made with a calorimetric transducer (TCG) which uses a thermocouple as a temperature sensor (Ref. 2). Approximately 2500 of these transducers have been fabricated and used for test measurements which ranged from 0.5 to 150 Btu/ft²-sec. Although these transducers provide satisfactory measurements, their sensitivity is low, and of greater consequence, the d-c signal produced

by the thermocouple is incompatible with the 20-kc carrier system in use. This incompatibility requires that chopper modulator units (Ref. 2) be employed with these transducers to permit their use with the 20-kc carrier instrumentation. Therefore, efforts have been made to develop a transducer which does not suffer from these aforementioned inadequacies. As a result of these efforts, a transducer called the RT gage has been developed. This new transducer has a sensitivity approximately 25 times greater than its predecessor, and it is used in a Wheatstone bridge circuit which operates directly into a carrier system without the necessity of a chopper modulator unit.

The gage developed (Fig. 1) uses a thin-film platinum resistance thermometer to sense the temperature of an aluminum disk which is exposed to the heat flux which is to be measured. The aluminum disk is mounted in a thermally insulated holder (nylon) and acts as a calorimetric mass. The film is sputtered (Refs. 3 and 4) on the back surface of the disk and is electrically insulated from it by a thin (0.00012 in.) anodized layer of aluminum.

Electrical connections to the film are made with small (0.001-in.-diam) copper leads which are attached with conductive epoxy cement. Other construction details are similar to the TCG and are given in Ref. 2. The thin-film resistance is nominally 150 Ω , and its temperature coefficient of resistance is approximately $1 \times 10^{-3} \Omega/\Omega/^\circ\text{F}$.

For a given measurement, a disk thickness is selected which will result in a maximum disk temperature rise of about 175 $^\circ\text{F}$; thicknesses of 0.010, 0.020, and 0.032 in. are in common use.

The basic theory enabling the slug calorimeter to be used for the measurement of heat-transfer rate is expressed by the equation (Refs. 2, 5, and 6):

$$\dot{q} = \rho l c_p \frac{dT}{dt} \quad (1)$$

This theory assumes that the calorimeter heat losses are negligible compared to its heat gains during measurement. Studies of the slug calorimeter have shown that this is a valid assumption for most hypervelocity test conditions; however, significant measurement errors can be incurred when the tunnel has a "hot start" (much higher heat-transfer rate during the tunnel start than during the period of desired measurement) and thin calorimeter disks (<0.005 in.) are used. Use of the RT gage reduces these errors since thicker disks can be used for a given measurement than could be used with a TCG because of the RT gage's increased sensitivity.

Typical Transducer Size Is 0.250-in. Diameter by 0.30 in. Long;
 Aluminum Disk Diameter Is 0.187 in.

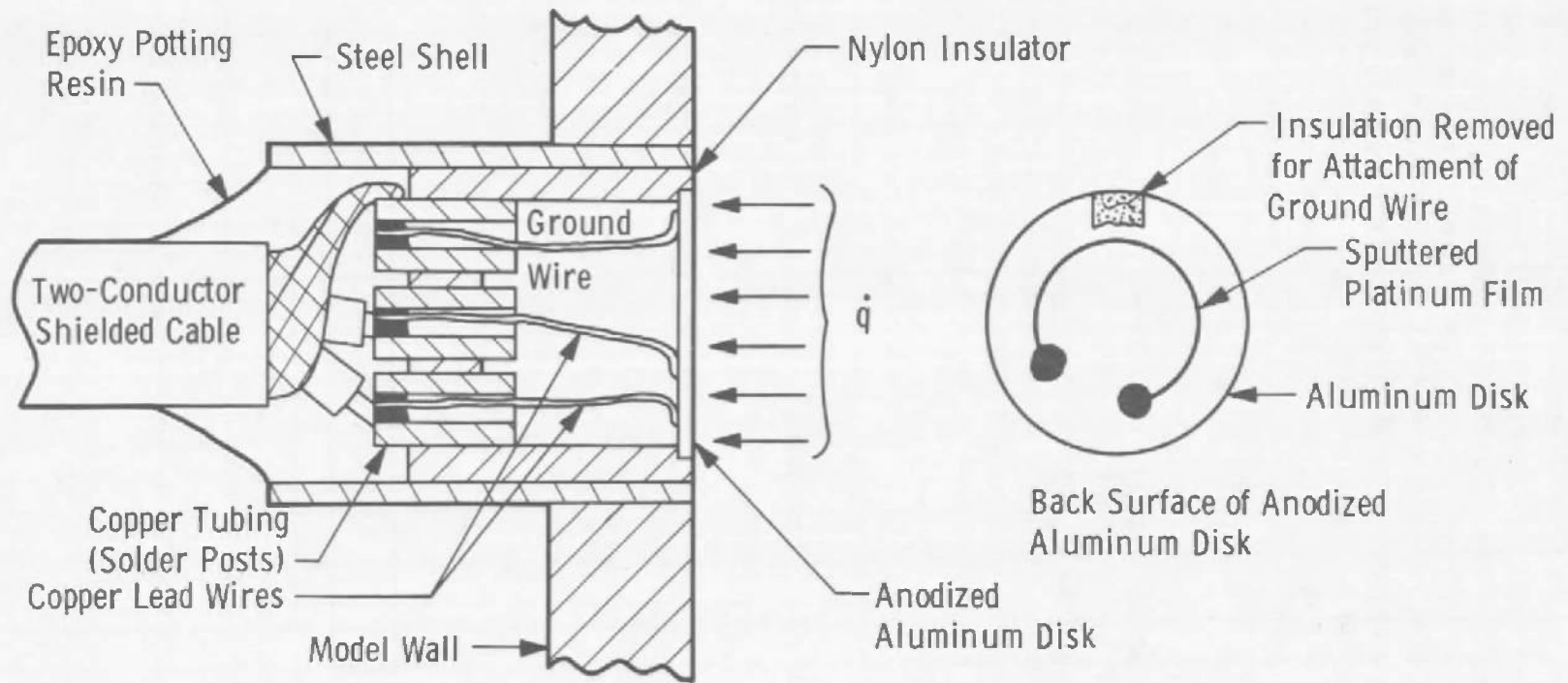

Fig. 1 Cross Section of Calorimeter-Type Heat-Transfer-Rate Transducer with Thin-Film Resistance Thermometer Temperature Sensor (RT Gage)

This theory also presupposes that the average temperature of the disk is indicated within allowable limits by the back surface temperature of the disk and that the time lag between the application of heat to the front surface of the calorimeter and the temperature response at the back surface is brief enough for the intended measurement application. The equation describing the time response of the slug calorimeter is approximated by the expression:

$$t \cong - \frac{\ell^2}{k\pi^2} \ln \left(\frac{1 - \frac{\dot{q}_{\text{indicated}}}{\dot{q}_{\text{input}}}}{2} \right) \tag{2}$$

which can be derived from expressions given in Ref. 7.

Figure 2 gives the time response of aluminum calorimeters of various thicknesses, and it shows that the theoretical time response of the RT gages is satisfactory for use in Tunnel F. (Calculations show that the time lag introduced by the anodized insulation and the thin film is approximately 1 μsec.)

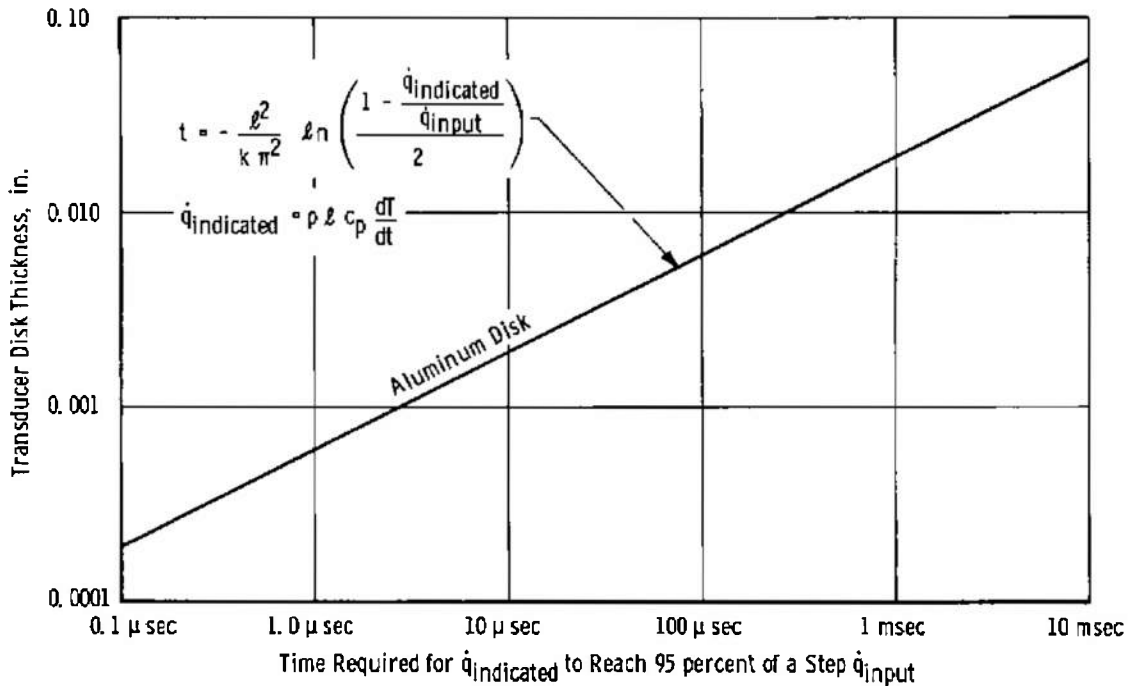

Fig. 2 Heat-Transfer-Rate Transducer (RT Gage) Time Response

The relationship between the thin-film temperature and its electrical resistance is:

$$R_T = R_o (1 + \alpha \Delta T) \tag{3}$$

Therefore, $R_T - R_o = \Delta R_o = R_o \alpha \Delta T$

and
$$\Delta T = \frac{\Delta R_o}{\alpha R_o} \quad (4)$$

The temperature coefficient of resistance has been found constant over the operable temperature range of this transducer.

Using the relationship of Eq. (4), Eq. (1) can be written:

$$\dot{q} = \frac{\rho \ell c_p}{\alpha R_o} \frac{dR_o}{dt} \quad (5)$$

By limiting the operating temperature of the transducer to a value (75 to 250°F) which permits ρ , ℓ , and c_p to be assumed constant, Eq. (5) can be written as:

$$\dot{q} = K_1 \frac{dR_o}{dt} \quad (6)$$

The resistance changes experienced by the thin film can be conveniently converted to voltage by the use of a Wheatstone bridge circuit as shown in Fig. 3. The output signal (ΔE_o) from the bridge caused by an increase in the resistance (ΔR_o) of the thin film is given by:

$$\Delta E_o = E \left(\frac{R_o + \Delta R_o}{R_o + \Delta R_o + R_2} - \frac{R_3}{R_1 + R_3} \right) \quad (7)$$

which can be rearranged as:

$$\Delta R_o = \frac{E(R_o R_1 - R_2 R_3) - \Delta E_o (R_1 + R_3) (R_o + R_2)}{\Delta E_o (R_1 + R_3) - E R_1} \quad (8)$$

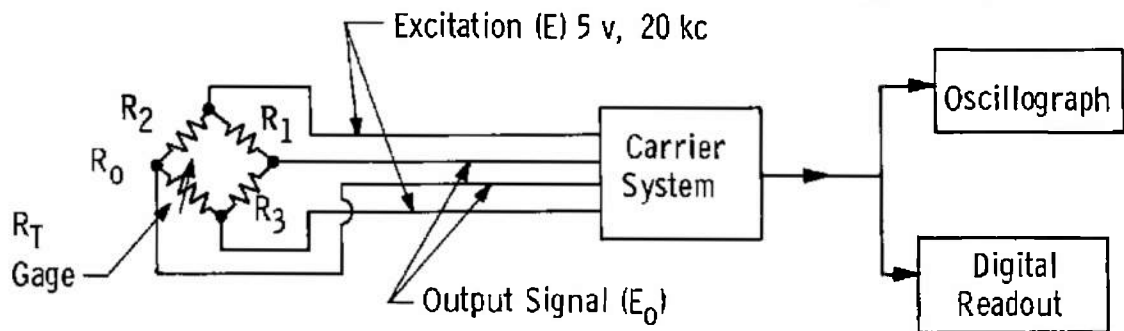

$$R_1 = R_2 = 700 \Omega$$

$$R_0 = R_3 = 150 \Omega$$

Fig. 3 Heat-Transfer-Rate Transducer Instrumentation System

It should be noted that the ΔR_0 term in the denominator of Eq. (7) results in nonlinearity; i. e., ΔE_0 is not directly proportional to ΔR_0 . However, by proper selection of the bridge resistances, the nonlinearity is insignificant in the operating range of the RT gage.

When the bridge components are selected so that $R_1 = R_2$ and $R_0 = R_3$, Eq. (8) becomes:

$$\Delta R_0 \cong \frac{\Delta E_0 (R_1 + R_3) (R_0 + R_2)}{ER_1} \quad (9)$$

since $\Delta E_0 (R_1 + R_3)$ is negligible in comparison to ER_1 .

Combination of Eqs. (5) and (9) gives:

$$\dot{q} = \frac{\rho l c_p}{\alpha R_0} \frac{(R_1 + R_3) (R_0 + R_2)}{ER_1} \frac{dE_0}{dt}$$

which can be reduced to:

$$\dot{q} = K_2 \frac{dE_0}{dt} \quad (10)$$

which shows that the derivative of the transducer-bridge circuit output with respect to time is directly proportional to the heat flux incident on the transducer.

Calibration of the RT gage is achieved by the application of a known heat flux to the gage and recording its time-resolved output signal. This permits evaluation of the constant K_2 . An oxy-acetylene flame is used as a heat flux source for gage calibrations (Ref. 8). Conventional shunt calibration techniques may be used to transfer gage calibrations from laboratory to tunnel areas. Tunnel data reduction requires multiplication of the gage calibration constant times the derivative of the gage output signal with respect to time at a given time point.

Tunnel tests have shown that the greater sensitivity of the RT gage results in several advantages over the thermocouple transducer:

1. A larger signal-to-noise ratio is realized.
2. Fewer gages are required to cover a given measurement range.
3. Thicker, more rugged disks can be used for a given measurement.
4. Lower heat-transfer rates can be measured (0.1 Btu/ft²-sec has been measured).

A typical tunnel data trace is shown in Fig. 4.

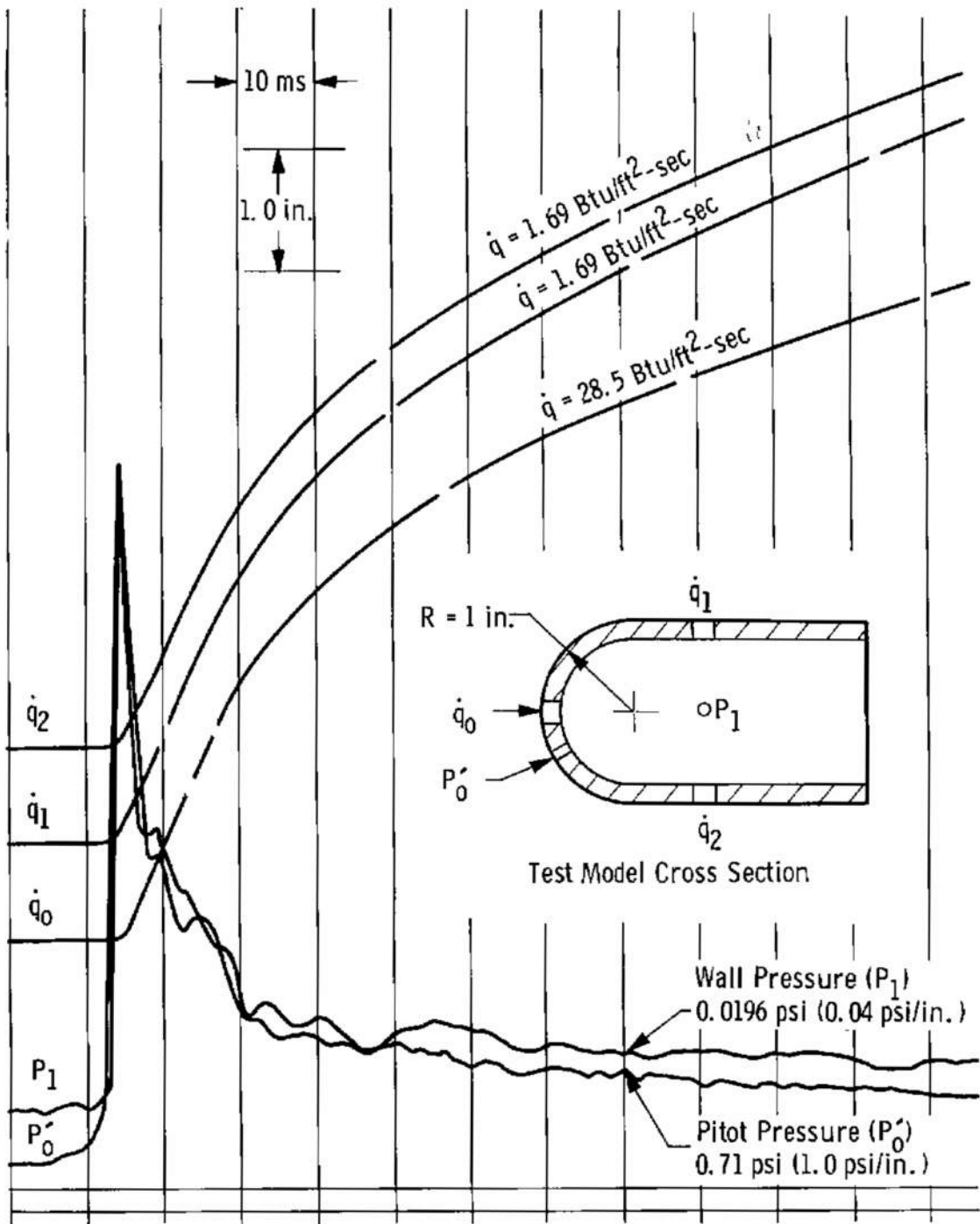
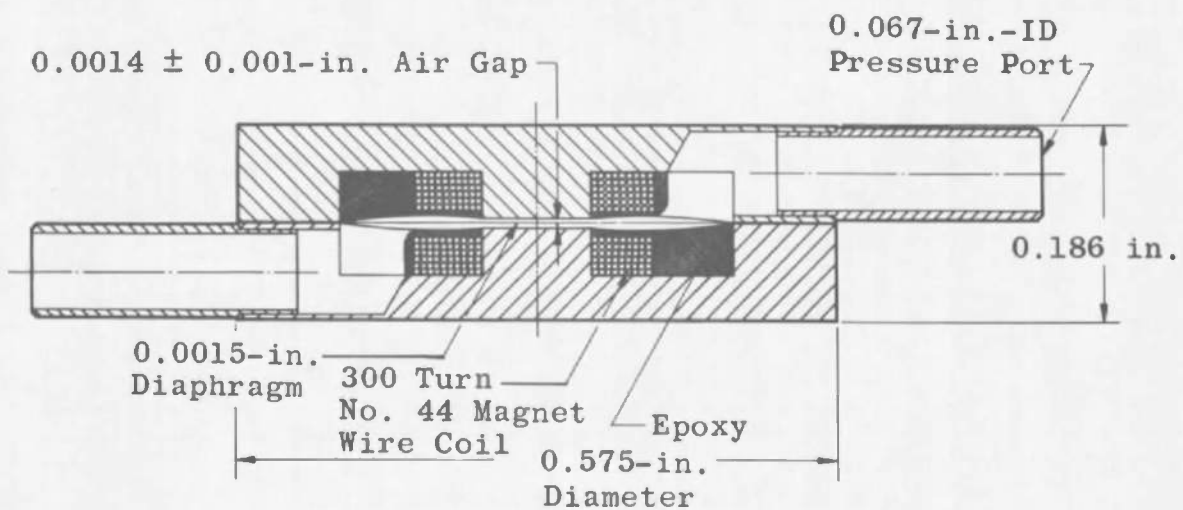
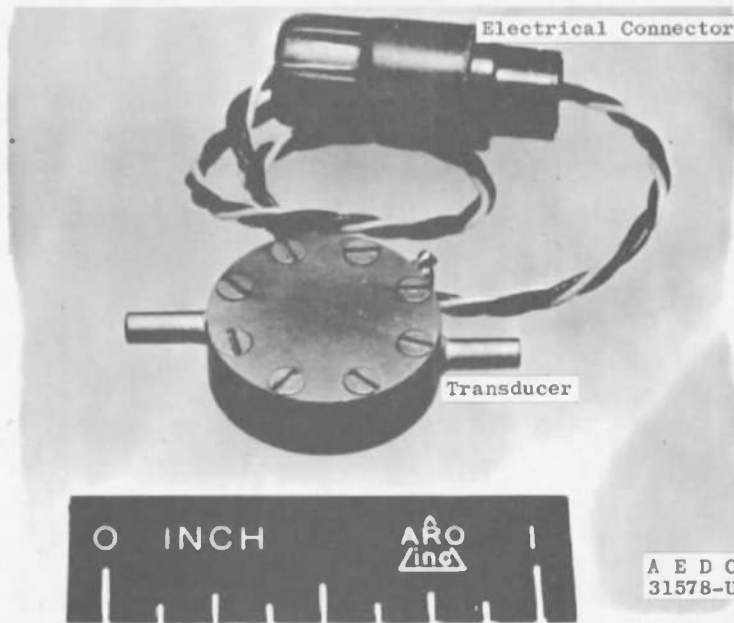

Fig. 4 Heat-Transfer-Rate and Pressure Oscillogram

SECTION III
PRESSURE MEASUREMENTS

Model pressure measurements in a hotshot tunnel require a small, fast-response transducer which can be placed in the test models. Such a transducer was developed at the AEDC in 1959 (Refs. 9 and 10). This transducer is a variable reluctance type (Fig. 5) and is built in full-scale pressure ranges of 0.1, 0.5, 3.0, and 10 psid to encompass the required measurement range of the tunnel.



Cross Section

Fig. 5 Variable Reluctance Wafer Pressure Transducer

This transducer has performed well during six years of usage but it has certain inherent limitations. Each transducer has a limited range, and the transducer is plagued by contaminants contained in the tunnel flow medium. These contaminating particles enter the transducer through its pressure ports and are deposited in the small gap (0.0014 in.) between the diaphragm and the transducer's coils or magnetic center pole piece. In this position, they can prevent the diaphragm from deflecting properly and/or distort the transducer's magnetic flux field. The large number of transducers in use (400), coupled with the frequency of repair which is required, results in the consumption of a large amount of time spent in maintenance.

In consideration of these limitations, a strain-gage-type transducer has been developed which does not possess these shortcomings. The transducer has the shape of a thin wafer (Fig. 6) permitting the installation of several transducers in a test model. A cross section of the

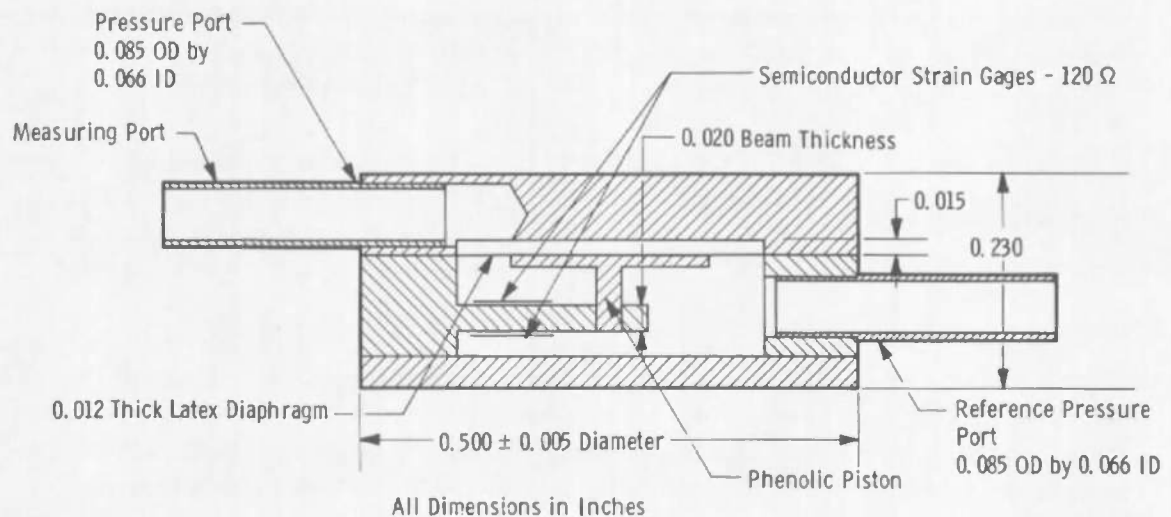
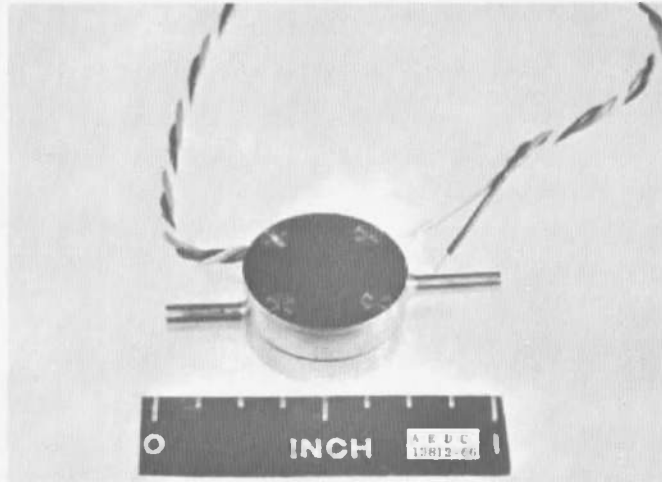

Fig. 6 Semiconductor Wafer Gage Assembly

transducer is also shown in Fig. 6. The transducer is a differential pressure measuring device with the higher pressure always being applied to the top port as shown in Fig. 6. Application of a differential pressure produces a force on the flexible, rubber (latex) diaphragm which is transmitted through the phenolic piston to the cantilever beam. The cantilever beam is instrumented with two semiconductor strain gages which sense the deflection of the beam. The relative stiffness of the diaphragm and cantilever beam is such that practically all of the restraint to the pressure loading is supplied by the cantilever beam.

The range of this transducer is 15 psid; its sensitivity is nominally 10 mv/psi when excited with 5 v. Combined hysteresis and nonlinearity of the transducer is ± 2 percent of full scale, and it has a resonant frequency of about 1300 cps. The resistance of the strain gages used is 120 Ω each, and their gage factor is 120. The transducer's coefficient of temperature sensitivity is 0.1 percent/ $^{\circ}$ F over the temperature range from 75 to 120 $^{\circ}$ F. Effects of temperature on electrical zero are low enough to be inconsequential in hotshot testing since the strain gages are isolated from the tunnel flow by the diaphragm and phenolic piston.

The response time of the transducer (time required to reach 95 percent of full output) to a pressure step of 0.1 psia has been measured as about 1.0 msec. Step inputs at higher absolute pressure levels result in shorter response times. A comparison of the response times and other characteristics of the semiconductor wafer and the variable reluctance wafer is shown in Table I.

The electrical configuration which the transducer assumes is as shown in Fig. 7. The two semiconductor strain gages form the active arms of a Wheatstone bridge circuit which can be excited with a-c or d-c voltages as great as 5 v. The carrier amplifier instrumentation system in use in the VKF permits full-scale pressure measurements ranging from 0.05 to 15 psid to be made with this transducer.

From data taken to date, indications are that the maintenance required with the semiconductor wafer transducer is practically nil in contrast with maintenance of the variable reluctance model. A test point is cited below:

Four semiconductor wafer gages and four variable reluctance transducers were employed for pitot pressure measurements of about 1 psi in the 100-in. hotshot tunnel for 15 consecutive runs. The variable reluctance transducers were equipped with particle traps to offer some protection from contamination, but the semiconductor wafers were not. None of the semiconductor gages had to be replaced, and their calibration

TABLE I
SEMICONDUCTOR WAFER AND VARIABLE RELUCTANCE WAFER
PRESSURE TRANSDUCER SPECIFICATIONS

Specifications	Semiconductor Wafer	Wafer Gage
Type	Semiconductor Strain Gage	Variable Reluctance
Range	0.05 to 15.0 psi	0.001 to 10.0 psi in Four Transducers 0 to 0.1, 0 to 0.5, 0 to 3.0, 0 to 10.0
Size	0.500-in. Diameter by 0.230 in. Thick	0.575-in. Diameter by 0.186 in. Thick
Excitation	5.0 vdc or vac	5.0 vrms 20 kc
Sensitivity	≈2 mv/v/psi	≈60 mv Full Scale for the Four Transducers
Hysteresis and Nonlinearity	±2 percent or Less of Calibrated Range	±2 percent or Less of Calibrated Range
Temperature Coefficient of Sensitivity	0.1 percent/°F (75 to 125°F)	0.03 to 0.06 percent/°F (32 to 140°F)
Resonant Frequency	≈13 kc	≈3 to 12 kc Depending on Range
Response Time (95-percent Excursion)	1.0 msec at 0.1 psia	0.9 msec at 0.1 psia

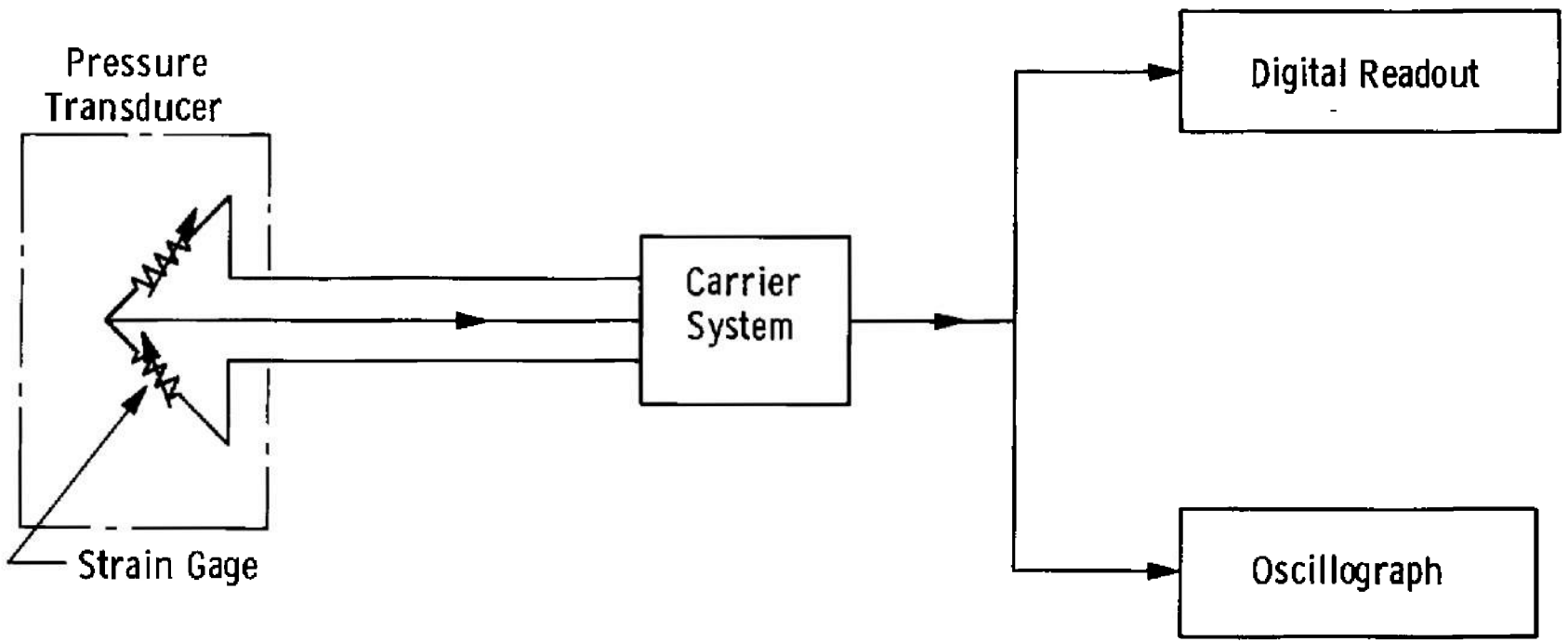

Fig. 7 Pressure Transducer Instrumentation System

factors remained constant during the series of runs. Upon completion of the tunnel tests, laboratory calibrations were made, and these calibrations agreed within 1 percent of the laboratory calibrations taken prior to tunnel entry. Of the four variable reluctance devices, six replacements were required during the 15 runs.

A typical oscillogram recorded during a hotshot tunnel run is shown in Fig. 4. This trace presents the output from two semiconductor wafers used to measure wall and pitot pressures on a 2-in. -diam hemispherical model. The pressure sensitivity of the wall transducer is 0.04 psi/in., with the absolute value being approximately 0.02 psi. The pitot transducer sensitivity is 1 psi/in., and pressure of approximately 0.7 psi is measured.

SECTION IV FORCE MEASUREMENTS

A six-component force balance has been developed for hotshot force measurements. The balance employs removable load cells and accelerometers which are instrumented with semiconductor strain gages. The accelerometers are used to compensate for inertial loads which result from vibration of the model support during the tunnel test period (Ref. 11). The balance has been built in two sizes: 1-in. OD by 5.683 in. long and 1-1/4-in. OD by 5.683-in. long. A simplified form of the arrangement of the load cells is shown in Fig. 8. A cross-sectional view of the balance and a test model are shown in Fig. 9. A photograph of the balance with its outer shell removed is shown in Fig. 10.

Strain gages which are used for instrumentation of the load cells are 120 Ω gages, and their gage factor is 120. The normal and side force load cells in the balance are identical. The sensor is a semiconductor gaged cantilever beam loaded through a flexured rod which is very limber in all directions except along an axis normal to the gaged surface of the cantilever. The rolling moment load cell is formed by a thin-walled cylinder which is gaged to provide torsional sensitivity. A bellows acts as the flexural unit which renders the cell relatively insensitive to all loads other than rolling moments. Each of the load cells is instrumented as a half-bridge circuit, and a flexible silicone compound is applied over the strain gages to insulate them thermally. This coating is required to prevent zero instability of the gages when they are exposed to the hot gases which circulate over them during tunnel testing. Load cell sensitivities are typically 3.5 mv/lb with 5-v bridge excitation. Linearity and repeatability are within the tolerances of the readout system ordinarily employed ($\approx \pm 2$ percent). Figure 11 is a photograph of the load cells.

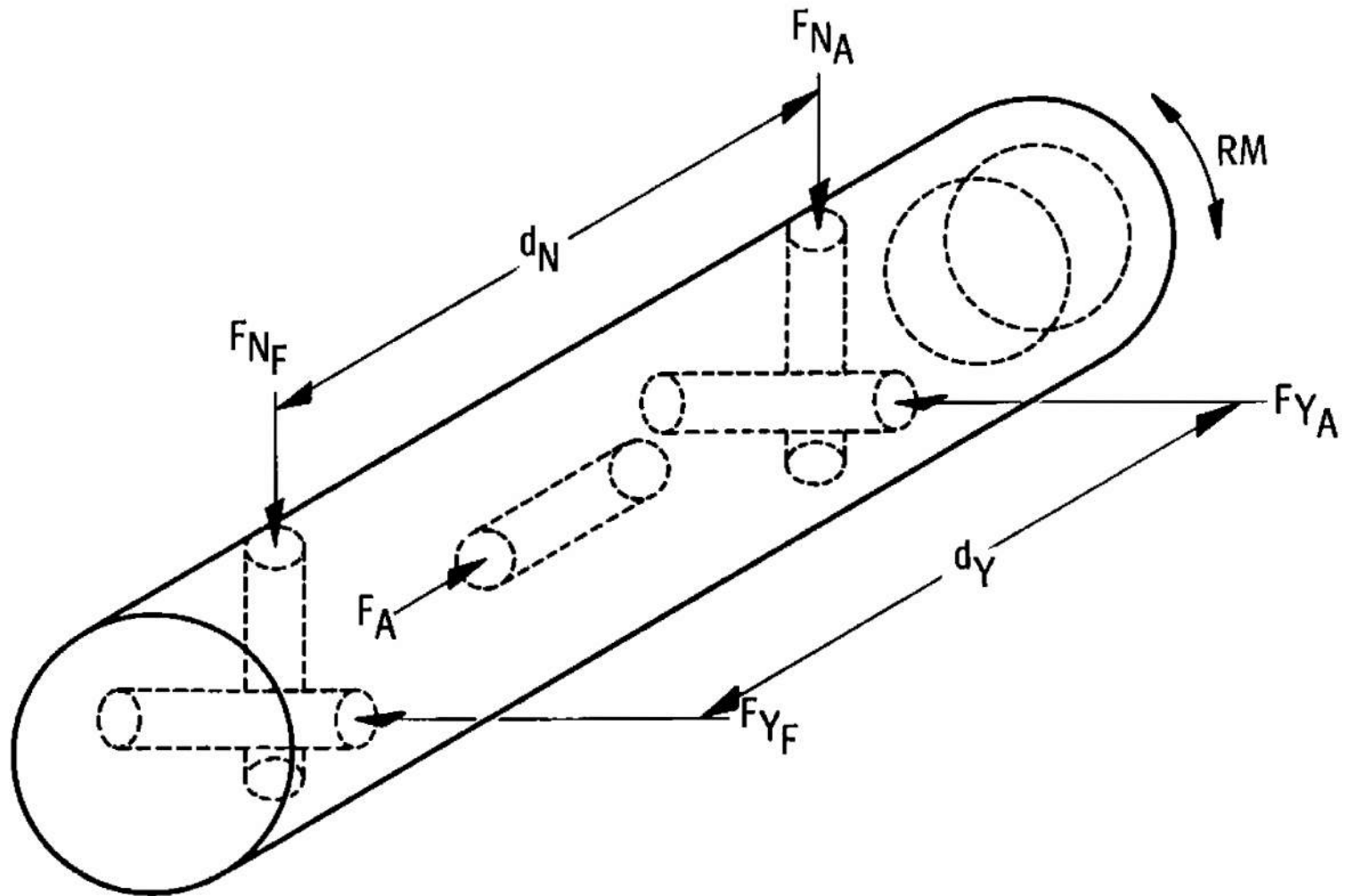

Fig. 8 Six-Component Balance Load Cell Positions

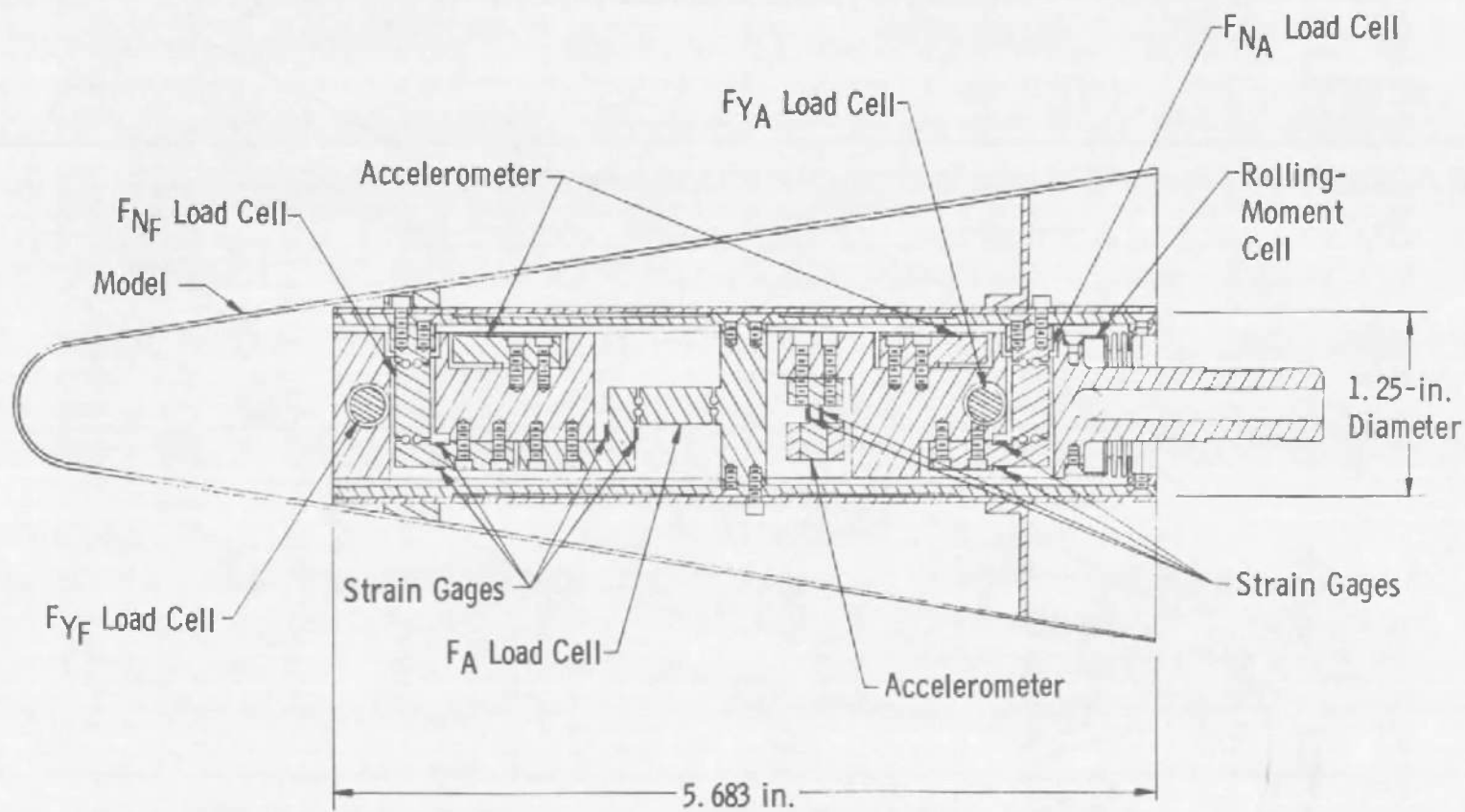

Fig. 9 Six-Component Balance Cross Section

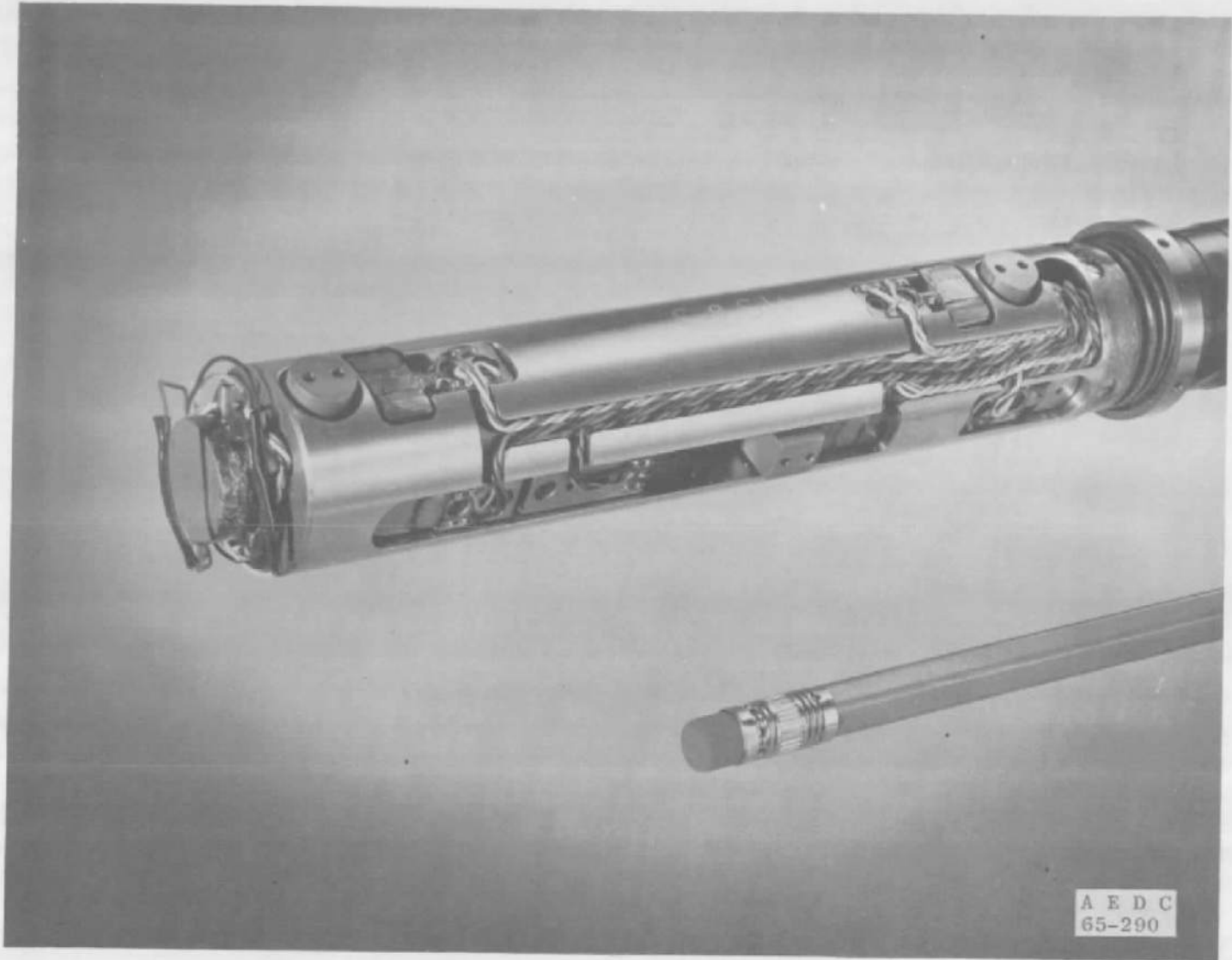

Fig. 10 Six-Component Balance Assembly

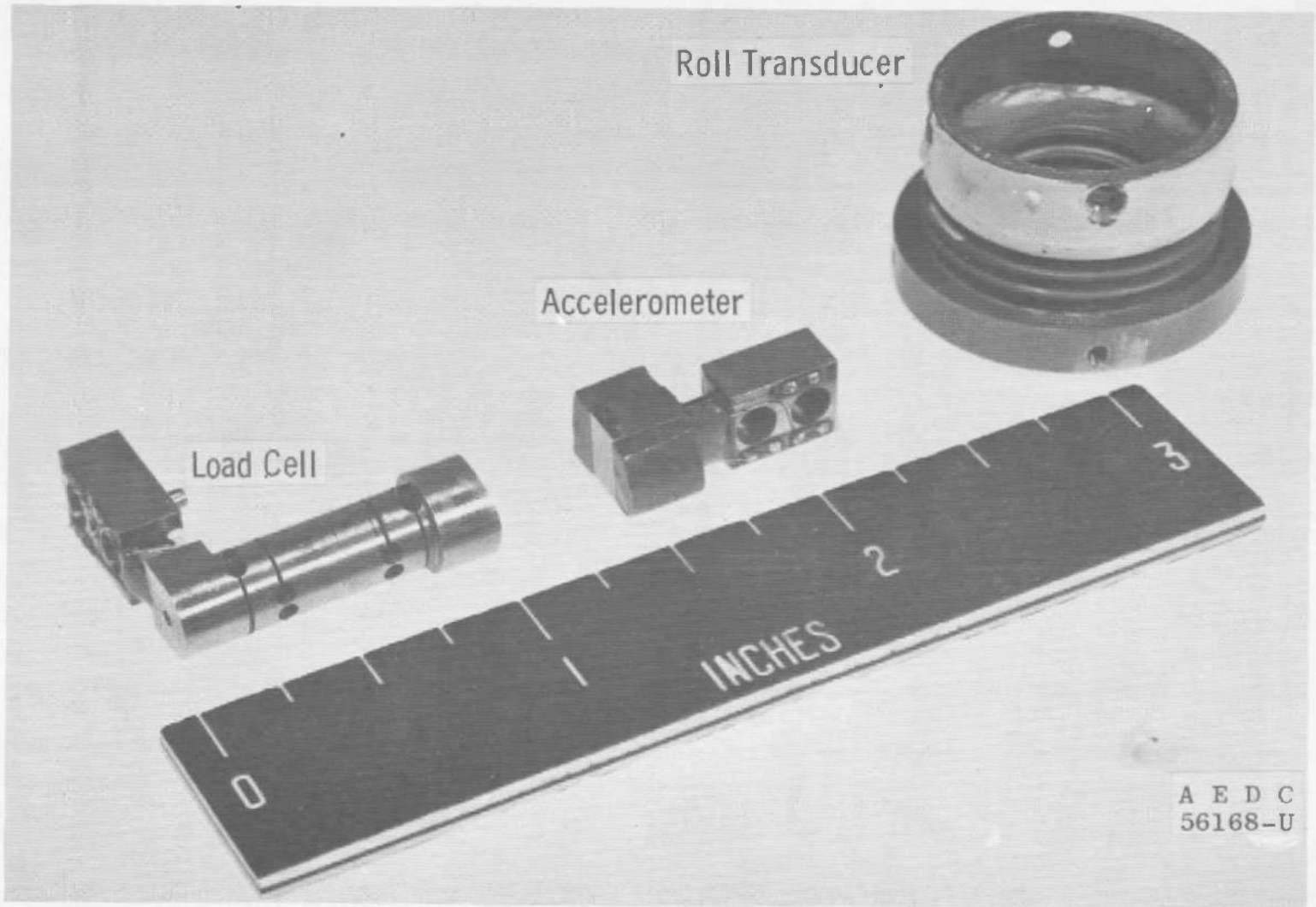

Fig. 11 Balance Components

The accelerometers which are used to compensate for the effects of model-support-system vibration are also shown in Fig. 11. These accelerometers are merely gaged cantilever beams with concentrated masses attached to the end of the beams. These gages are also insulated thermally with a silicone compound. Except for the rolling moment, one accelerometer is required for each force component. No compensation is required for rolling moment.

By referring to Figs. 8 and 9, one can see how the balance functions. Each of the load cells attaches to an external shell which is supported entirely by the load cells. Each of the cells provides stiffness in one direction, and in unison they provide stiffness in all directions, each helping to support the other in a particular plane. The model attaches to the external shell, and aerodynamic forces on the model are transmitted through the shell to individual load cells. As can be seen in Fig. 8, the cells are arranged in such a way that a forward and an aft, normal and side force are measured along with axial force and rolling moment. By summing these forces in an appropriate fashion, the six-components of force which can act on a body are determined thusly:

$$\begin{aligned}
 \text{Yaw Force} &= F_{Y_A} + F_{Y_F} \\
 \text{Yaw Moment}^* &= (F_{Y_F} - F_{Y_A}) d_Y \\
 \text{Normal Force} &= F_{N_A} + F_{N_F} \\
 \text{Pitching Moment}^* &= (F_{N_F} - F_{N_A}) d_N \\
 \text{Rolling Moment} &= RM \\
 \text{Axial Force} &= F_A
 \end{aligned}$$

* Moment reference points are midpoints between subject load cells.

Compensation of inertial loads produced by vibration of the model-support is achieved by electrically summing the outputs of individual load cells with their corresponding accelerometers as shown in Fig. 12. The accelerometers sense the acceleration of the model-support; the load cells measure this acceleration plus the aerodynamic load imposed on the test model. With appropriate accelerometer and load cell gains, their summed signal represents the aerodynamic force with no acceleration component.

The interactions (apparent loads in load cells which are not being loaded) of these balances are very low, generally less than 1 to 2 percent,

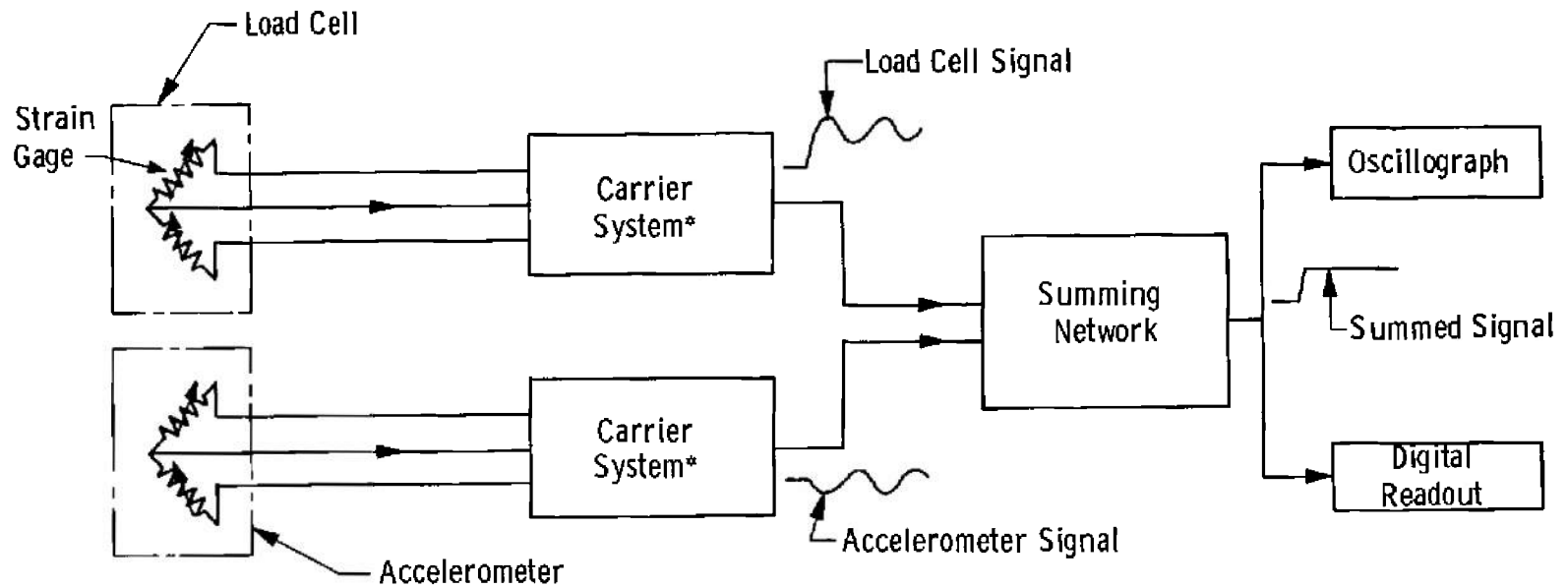

*Carrier system consists of regulated 5-v, 20-kc supply, bridge completion network, amplifier, and demodulator.

Fig. 12 Block Diagram of Instrumentation Required for Measurement of One Component of Force

with the exception of side force on rolling moment which can be relatively large (5 percent). The values of the interactions present in a typical six-component balance are given in matrix form in Table II.

The load range of this type balance is determined primarily by the load cell dimensions. Balances fabricated to date have had capabilities of measuring 20 lb on any cell and rolling moments of 10 in. -lb. Forces as low as 0.02 lb have been resolved with the instrumentation system in use.

The resonant frequencies presented by this force measuring system are dependent on both the mass and mass moment of inertia of the model employed. For a typical model constructed of balsa, magnesium, and fiberglass (weighing between 100 and 200 g and with a mass moment of inertia of approximately 0.07 in. -lb/sec²), these frequencies are typically 1200 cps with the exception of rolling moment which may be of the order of 400 cps. Accelerometer resonant frequencies are approximately 1500 cps. Extreme care must be exercised in model design and construction to avoid low frequency resonances.

If model resonant frequencies are kept relatively high, data recording may be made with a recording oscillograph employing galvanometers with a resonant frequency of 200 cps. This provides adequate response time for the run durations experienced in the VKF hotshot tunnels. The galvanometers also serve as filters and remove the resonant frequencies of the load cells, accelerometers, and model from the oscillograph trace. A typical six-component test trace is given in Fig. 13. The individual component sensitivities are as given on the trace.

SECTION V CONCLUSIONS

Efforts directed towards the improvement of heat-transfer-rate, pressure, and force measurements in the AEDC hotshot facilities have resulted in the development of transducers whose test performance has shown them to be superior to their predecessors.

TABLE II
SIX-COMPONENT FORCE BALANCE INTERACTION MATRIX

Interactions:

	F_{NF}	F_{NA}	F_A	F_{YF}	F_{YA}	RM
F_{NF}	---	**	0.003	0.010	0.002	0.023
F_{NA}	**	---	0.02	0.002	-0.001	0.002
F_A	0.00	0.00	---	0.00	0.00	0.00
F_{YF}	0.005	0.00	-0.005	---	**	-0.004
F_{YA}	0.00	-0.003	-0.002	**	---	-0.058
RM	0.00	0.04	0.00	0.00	0.00	---

**Zero by Definition

EXAMPLES: $\frac{\partial F_A}{\partial F_{NA}} = 0.02$; $\frac{\partial F_{YF}}{\partial F_{NF}} = 0.010$

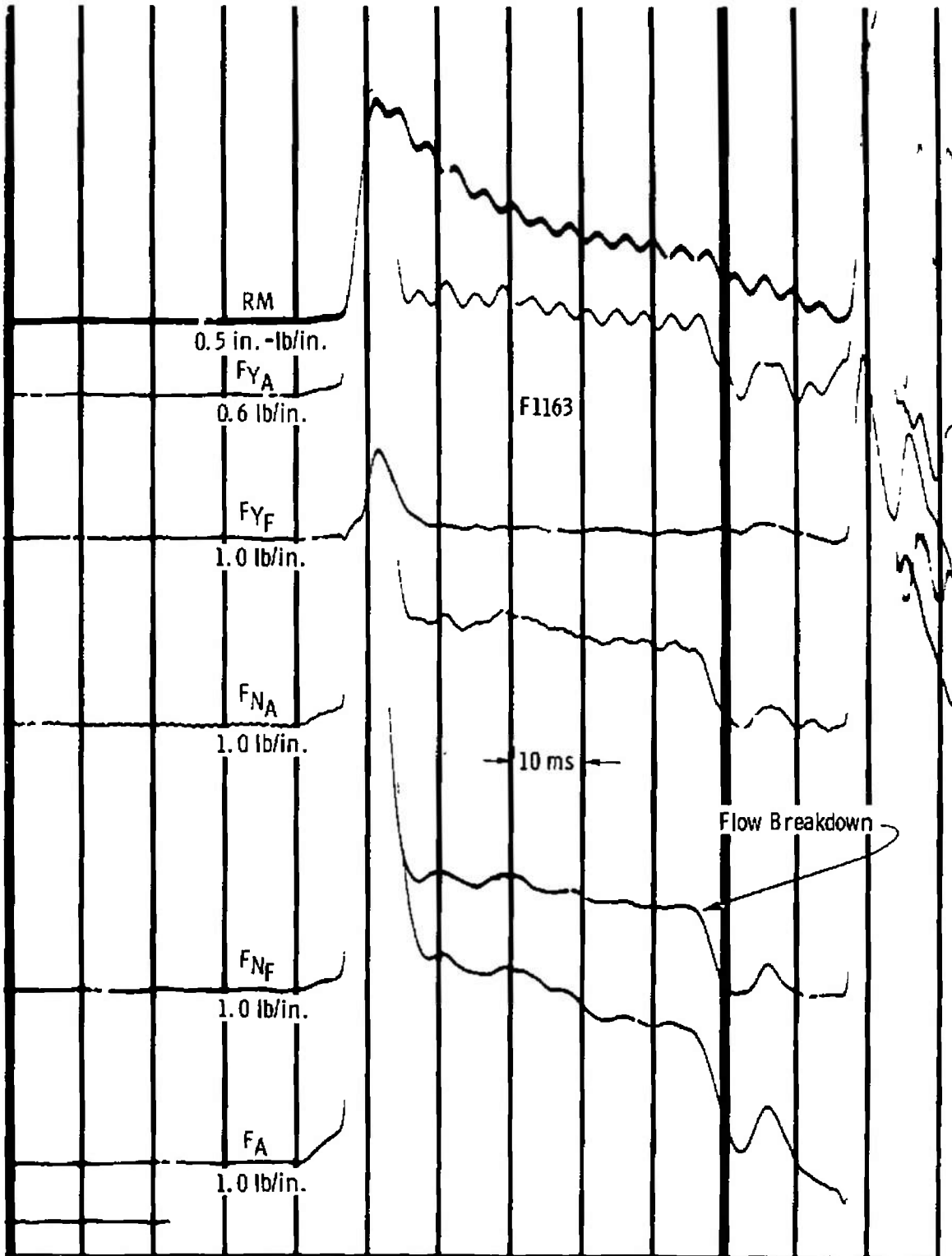

Fig. 13 Six-Component Force Balance Oscillogram

REFERENCES

1. Ball, H. W. "Calibration of the 100-inch Hypervelocity Tunnel (F)." AEDC-TDR-63-46 (AD298279), March 1963.
2. Ledford, R. L. "A Device for Measuring Heat Transfer Rates in Arc Discharge Hypervelocity Wind Tunnels." AEDC-TDR-62-64 (AD275740), May 1962.
3. Belser, R. B. and Hickun, W. H. "Simple, Rapid Sputtering Apparatus." The Review of Scientific Instruments, Vol. 27, No. 5, pp. 293-296 (May 1956)
4. Blevis, E. H. "Glow Discharge Sputtering - Theory and Practice." Distributed by the R. D. Mathis Co., Long Beach, California, February 1964.
5. Jones, D. L. "Reduction of Data from the Hy-Cal-C-1080 Calorimeter." STL/TOR 6120-6242-N-0-000, Jan. 11, 1962.
6. Malone, E. H. "Heat Flux Measurements." Boeing Report D2-35057 January 1963.
7. Carslaw, H. S. and Jaeger, J. C. Conduction of Heat in Solids. Second Edition, Oxford, Clarendon Press, 1959.
8. Morgan, D. C. and Andrews, J. C. "Morgandyne Heat-Transfer Transducer and a Flame-Torch Calibration Technique for Hypervelocity Wind Tunnels." AEDC-TR-60-1, February 1960.
9. Smotherman, W. E. "A Miniature Wafer-Style Pressure Transducer." AEDC-TR-60-11 (AD232236), October 1960.
10. Smotherman, W. E. and Maddox, W. V. "Variable Reluctance Pressure Transducer Development." AEDC-TDR-63-135 (AD410171), July 1963.
11. Edenfield, E. E. and Ledford, R. L. "Compensation of Dynamic Sting Effects in Hotshot Force Measurement." AEDC-TDR-62-122 (AD277055), June 1962.

DOCUMENT CONTROL DATA - R&D

(Security classification of title, body of abstract and indexing annotation must be entered when the overall report is classified)

1 ORIGINATING ACTIVITY (Corporate author) Arnold Engineering Development Center ARO, Inc., Operating Contractor Arnold Air Force Station, Tennessee		2a REPORT SECURITY CLASSIFICATION UNCLASSIFIED	
		2b GROUP N/A	
3 REPORT TITLE RECENT DEVELOPMENTS IN HEAT-TRANSFER-RATE, PRESSURE, AND FORCE MEASUREMENTS FOR HOTSHOT TUNNELS			
4 DESCRIPTIVE NOTES (Type of report and inclusive dates) N/A			
5 AUTHOR(S) (Last name, first name, initial) Ledford, R. L., Smotherman, W. E., and Kidd, C. T., ARO, Inc.			
6. REPORT DATE January 1967		7a TOTAL NO OF PAGES 29	7b NO OF REFS 11
8a CONTRACT OR GRANT NO. AF40(600)-1200		9a ORIGINATOR'S REPORT NUMBER(S) AEDC-TR-66-228	
b. PROJECT NO. c. Program Element 65402234		9b. OTHER REPORT NO(S) (Any other numbers that may be assigned this report) N/A	
10 AVAILABILITY/LIMITATION NOTICES Distribution of this document is unlimited.			
11. SUPPLEMENTARY NOTES Available in DDC		12. SPONSORING MILITARY ACTIVITY Arnold Engineering Development Center Air Force Systems Command Arnold Air Force Station, Tennessee	
13 ABSTRACT Heat-transfer rate, pressure, and force are essential parameters which must be measured in the operation of a hotshot wind tunnel. Transducers of the proper size, range, and time reponse required for making these measurements are not generally available on a commercial basis. Therefore, developmental programs directed towards satisfaction of these measurement requirements were undertaken at the AEDC. As a result of these programs, transducers were developed which enabled these measurements to be made. Recent developments have resulted in measurement capabilities and accuracies which are superior to those of transducers which were developed early in these programs (about 1960). A description of these improved transducers and their performance characteristics are contained herein.			

14 KEY WORDS	LINK A		LINK B		LINK C	
	ROLE	WT	ROLE	WT	ROLE	WT
heat-transfer rate pressure force wind tunnels transducers						

INSTRUCTIONS

1. **ORIGINATING ACTIVITY:** Enter the name and address of the contractor, subcontractor, grantee, Department of Defense activity or other organization (*corporate author*) issuing the report.

2a. **REPORT SECURITY CLASSIFICATION:** Enter the overall security classification of the report. Indicate whether "Restricted Data" is included. Marking is to be in accordance with appropriate security regulations.

2b. **GROUP:** Automatic downgrading is specified in DoD Directive 5200.10 and Armed Forces Industrial Manual. Enter the group number. Also, when applicable, show that optional markings have been used for Group 3 and Group 4 as authorized.

3. **REPORT TITLE:** Enter the complete report title in all capital letters. Titles in all cases should be unclassified. If a meaningful title cannot be selected without classification, show title classification in all capitals in parenthesis immediately following the title.

4. **DESCRIPTIVE NOTES:** If appropriate, enter the type of report, e.g., interim, progress, summary, annual, or final. Give the inclusive dates when a specific reporting period is covered.

5. **AUTHOR(S):** Enter the name(s) of author(s) as shown on or in the report. Enter last name, first name, middle initial. If military, show rank and branch of service. The name of the principal author is an absolute minimum requirement.

6. **REPORT DATE:** Enter the date of the report as day, month, year; or month, year. If more than one date appears on the report, use date of publication.

7a. **TOTAL NUMBER OF PAGES:** The total page count should follow normal pagination procedures, i.e., enter the number of pages containing information.

7b. **NUMBER OF REFERENCES:** Enter the total number of references cited in the report.

8a. **CONTRACT OR GRANT NUMBER:** If appropriate, enter the applicable number of the contract or grant under which the report was written.

8b, 8c, & 8d. **PROJECT NUMBER:** Enter the appropriate military department identification, such as project number, subproject number, system numbers, task number, etc.

9a. **ORIGINATOR'S REPORT NUMBER(S):** Enter the official report number by which the document will be identified and controlled by the originating activity. This number must be unique to this report.

9b. **OTHER REPORT NUMBER(S):** If the report has been assigned any other report numbers (*either by the originator or by the sponsor*), also enter this number(s).

10. **AVAILABILITY/LIMITATION NOTICES:** Enter any limitations on further dissemination of the report, other than those

imposed by security classification, using standard statements such as:

- (1) "Qualified requesters may obtain copies of this report from DDC."
- (2) "Foreign announcement and dissemination of this report by DDC is not authorized."
- (3) "U. S. Government agencies may obtain copies of this report directly from DDC. Other qualified DDC users shall request through _____."
- (4) "U. S. military agencies may obtain copies of this report directly from DDC. Other qualified users shall request through _____."
- (5) "All distribution of this report is controlled. Qualified DDC users shall request through _____."

If the report has been furnished to the Office of Technical Services, Department of Commerce, for sale to the public, indicate this fact and enter the price, if known.

11. **SUPPLEMENTARY NOTES:** Use for additional explanatory notes.

12. **SPONSORING MILITARY ACTIVITY:** Enter the name of the departmental project office or laboratory sponsoring (*paying for*) the research and development. Include address.

13. **ABSTRACT:** Enter an abstract giving a brief and factual summary of the document indicative of the report, even though it may also appear elsewhere in the body of the technical report. If additional space is required, a continuation sheet shall be attached.

It is highly desirable that the abstract of classified reports be unclassified. Each paragraph of the abstract shall end with an indication of the military security classification of the information in the paragraph, represented as (TS), (S), (C), or (U)

There is no limitation on the length of the abstract. However, the suggested length is from 150 to 225 words.

14. **KEY WORDS:** Key words are technically meaningful terms or short phrases that characterize a report and may be used as index entries for cataloging the report. Key words must be selected so that no security classification is required. Identifiers, such as equipment model designation, trade name, military project code name, geographic location, may be used as key words but will be followed by an indication of technical context. The assignment of links, rules, and weights is optional.