

AD 644698

OCD Work Unit No. III3A
USNRDL-TR-1064
27 January 1965

DESIGN OF ROOF WASHDOWN SYSTEMS
(FINAL REPORT)

by
R. H. Heiskell

CLEARINGHOUSE FOR FEDERAL SCIENTIFIC AND TECHNICAL INFORMATION			
Hardcopy	Microfiche		
\$3.00	\$.65	59 pp	as
1 ARCHIVE COPY			

DDC
RECEIVED
JAN 9 1967
C

U.S. NAVAL RADIOLOGICAL
DEFENSE LABORATORY

SAN FRANCISCO · CALIFORNIA · 94135

Best Available Copy

F

TECHNICAL DEVELOPMENTS BRANCH
R. R. Soule, Head

CHEMICAL TECHNOLOGY DIVISION
R. Cole, Head

ADMINISTRATIVE INFORMATION

The work reported was part of a project sponsored by the Office of Civil Defense, under Contract No. CDM-SR-59-54, Work Unit 1113A.

ACKNOWLEDGMENT

The author is grateful to Mr. W. S. Kehrer for his assistance in planning and carrying out the roof washdown studies and presentation of the data, to N. J. Vella for his outstanding assistance in conducting the washdown studies, to J. Pond for his assistance in developing the basic washdown design, and to A. J. Guay for his assistance in reducing the data. The assistance rendered by A. R. Dale in preparing the cost estimates was invaluable.

DDC AVAILABILITY NOTICE

ACCESSION FOR	Distribution of this document is unlimited.
CFSTI	WRITE SECTION <input checked="" type="checkbox"/>
DDC	DDP SECTION <input type="checkbox"/>
ORIGINATOR'S	Per statement
JOB: 10.1107	on Doc
BY	fm
DISTRIBUTION/AVAILABILITY CODES	
DIST.	AVAIL. MOD/ or SPECIAL
1	

Eugene P. Cooper
Eugene P. Cooper
Technical Director

OCD REVIEW NOTICE

This report has been reviewed in the Office of Civil Defense and approved for publication. Approval does not signify that the contents necessarily reflect the views and policies of the Office of Civil Defense.

D. C. Campbell
D. C. Campbell, CAPT USN
Commanding Officer and Director

ABSTRACT

Roof washdown studies were conducted on typical roofing surfaces and a basic washdown system was developed. An analysis of the roof washdown countermeasure showed it to be valuable only on buildings with heavily shielded walls or where the occupants are confined to the center of a building with a very large floor area. A complete recirculating roof washdown system will cost only 45 % of the cost of a concrete roof that would give a similar reduction of 98 % in the roof contribution to gamma radiation exposure inside the structure.

SUMMARY

Problem

To develop design specification for a roof washdown system.

Findings

A complete recirculating roof washdown system on a fiberglass epoxy laminated roof will cost only 45 % of the cost of a 12-inch concrete roof that would give a similar reduction in the roof contribution to the total gamma radiation exposure inside the building.

Rotary lawn type sprinklers when properly installed in sufficient number will remove 95 to 98 % of fallout particles from all five of the standard roofing surfaces tested at most slopes.

CONTENTS

ABSTRACT 1
SUMMARY 11

CHAPTER 1 INTRODUCTION 1
1.1 Background 1
1.2 Studies of Basic Principles of Transport by Water Films 2
1.3 Scope of the Roof Washdown Development Project 3
1.4 Scope of This Report 6

CHAPTER 2 SUMMARY OF ROOF WASHDOWN EXPERIMENTS 8
2.1 Experimental Set-Up 8
2.1.1 Roofing Surfaces 8
2.1.2 Water System 8
2.1.3 Fallout Disperser 11
2.2 Experimental Procedures 11
2.3 Results and Discussion 15
2.3.1 Flooding Nozzle Results 15
2.3.2 Rotary Nozzle Results 16
2.3.3 Effect of Deposition on Dry Surfaces vs Wetted Surfaces 23
2.3.4 Effect of Obstructions on Washdown Effectiveness 23

CHAPTER 3 ROOF WASHDOWN DESIGN 26
3.1 Washdown Limitations 26
3.2 Basic Design 26
3.3 Reduction of Radiation Exposure 28
3.4 Cost of Roof Washdown vs Concrete Roofs 36
3.5 Limitation of Estimates 38

CHAPTER 4 CONCLUSIONS AND RECOMMENDATIONS 40
4.1 Conclusions 40
4.2 Recommendations 41

REFERENCES 43

APPENDIX A CALCULATION OF DOSAGE REDUCTION FACTORS IN SIMPLE WINDOWLESS ABOVE-GROUND BUILDINGS 45

APPENDIX B CONSTRUCTION COST ESTIMATES 47

TABLES

1	Washdown Effectiveness of Rotary Nozzle Compared to that of Flooding Nozzles Giving the Same Flow Surface: Fiberglass-Epoxy Laminate	18
2	Washdown Effectiveness of Rotary Nozzle Compared to that of Flooding Nozzles Giving the Same Flow Surface: Roll Roofing	19
3	Washdown Effectiveness of Rotary Nozzle Compared to that of Flooding Nozzles Giving the Same Flow Surface: Aluminum Shingles Installation II.	20
4	Washdown Effectiveness of Rotary Nozzle Compared to that of Flooding Nozzles Giving the Same Flow Surface: Composition Shingles Installation II	21
5	Washdown Effectiveness of Rotary Nozzle Compared to that of Flooding Nozzles Giving the Same Flow Surface: Corrugated Galvanized Steel.	22
6	Washdown Turned on After Fallout was Deposited	24
7	Ground Contribution Through Walls as Fraction of Free-Field Exposure	34
8	Factors Contributing to the Interior Exposure of Windowless Buildings with 30 ft High, 18-inch-thick Concrete Walls. . . .	34
9	Total Accumulated Exposure to Personnel in the Center of the Ground Floor of Windowless Buildings, Based on an Accumulated Free-Field Exposure of 5,000 r	35
10	Cost of Installing a Roof Washdown System on an Existing Roof.	37
11	Comparison of Roofing Material Cost	37
12	Comparative Costs of Concrete Roof and Roof Washdown on Light Roof Structure for a 4000 ft ² (50 x 80 ft) Building . .	39
A.1	Calculation of Exposure Reduction Factors in Simple, Windowless, Above-Ground Buildings	46

FIGURES

1	Water Surface Waves	4
2	Water Surface Profiles	5
3	Test Plane Raised to a 1:4 Slope	9
4	Flooding Nozzle Manifold	10
5	Rotary Nozzle.	12
6	Individual Fallout Dispenser	13
7	Sieve Used to Collect Particles Removed from Roof.	14
8	Build-Up of Small Particles Around Larger Spherical Particles. .	25
9	Basic Washdown System For 4000 sq. ft. Radiologically Protected Building	29-30
10	Basic Washdown System For 4000 sq. ft. Radiologically Protected Building	31-32

CHAPTER I

INTRODUCTION

Many installations have a requirement for continuous 24-hour-a-day operation of certain facilities. During a nuclear attack or subsequent to a nuclear detonation, these installations may be located in a highly radioactive fallout area. The personnel operating the essential facilities therefore must be protected from the high-level radiation field that may result. This can be accomplished by constructing the building with heavy shielding in the walls and roof.

Roof washdown has been proposed as a method of removing the contamination from building roofs, thus reducing the amount of costly shielding that would otherwise be necessary for comparable dosage reduction. Roof washdown is a system for transporting the fallout particles from the roof by a continuous flow of water. A recirculating water system was recommended in Ref. 1 which would re-use the washdown water after running it through a settling and filtration tank. A roof washdown system utilizing recirculated water has the advantage of being able to supply the relatively large volume of water required and keep the system operative even though the water supply to the building may be cut off as a result of a nuclear detonation.

1.1 BACKGROUND

The flushing of building roofs with water to remove radiological fallout was proposed a number of years ago as a radiological countermeasure, but the first development work on a washdown system was directed towards its application to Navy ships. Development tests were conducted in 1949 with simulants of contaminated seawater sprayed onto vertically mounted 1-ft² plates; 99 % of the liquid simulant was removed when the surface was covered with a sheet of water, prior to and during contamination.²

In June 1951, tests were conducted by the Bureau of Ships on a destroyer to determine whether the salt-water pumping capacity of a ship were sufficient to adequately decontaminate its weather surfaces. Tests were then conducted by NRDL on the USS Worcester (CL-144) during January 1952, using non-radioactive dyes as simulants.³ The results of the Worcester tests confirmed the 99-% effectiveness results obtained in laboratory tests on 1-ft² plates. In these tests, the creation of a water curtain was accomplished chiefly by varying the placement of the spray nozzles and visually observing their effectiveness until maximum wetting of the surface was obtained. Later, in July 1952, similar qualitative tests were carried out on the aircraft carrier USS Shangri-La (CV-38). The same order of effectiveness was reported.⁴ At Operation CASTLE, installed washdown systems on test ships were found to be 87 to 94 % effective in removing the radioactive fallout from a thermonuclear detonation.⁵ The contaminant deposited on the ships during these tests contained a high percentage of insoluble radioactive coral particles as well as liquid contaminant. Since these coral particles closely resemble the type of particulate material that may be deposited on building roofs, it was realized, when attention was focused on roof washdown, that the development of an effective roof washdown system might be more difficult to accomplish than originally thought.

1.2 STUDIES OF BASIC PRINCIPLES OF TRANSPORT BY WATER FILMS

A series of laboratory studies was conducted to provide a better understanding of the basic principles involved in the transport of particulate matter by water films. These studies were conducted on plate glass which provided an ideally smooth surface to investigate the effect of the many variables other than surface roughness.

It was observed, for a near horizontal surface, (Ref. 6) that irregularly shaped silica particles of the fallout particle-size range moved with starts and stops, with pauses of various lengths of time. There was no apparent pattern in the length of the pauses or the distance traveled while in motion.

Raising the plane to the slightest slope produced gravity or surface waves which contributed greatly to the movement of the particles. Studies of this wave action on the transport of particulate matter were reported in references 7 to 10 and summarized in reference 11.

A typical wave formation is shown in Fig. 1. The waves induced a pulsing action on the particles as they passed over them. The particles at rest were jarred loose by the waves and were moved along at the same velocity as the wave for a short distance. The transport velocity of the particles which were in motion at the time a wave passed over them was increased to the velocity of the waves for a short distance. After the particles were given such a boost by the wave passing over, they continued to move with starts and stops as described above.

At all slopes the gravity wave action becomes the biggest factor in the transport of particulate matter on any surface. As the slope increases the water film thins out. The thinning out of the film resulted in the increase in the frequency of the waves as shown in Fig. 2 which is a typical plot of a water surface profile. It was also shown in these studies that the wave development is accomplished with relatively low water flow rate which points out that effective transport of fallout particles does not necessarily result from large volumes of washdown water, but efficient use of the water. This also indicates the possibility of developing more efficient washdown systems through the use of special methods of applying the water to the roofing surface.

1.3 SCOPE OF THE ROOF WASHDOWN DEVELOPMENT PROJECT

The effectiveness of a roof washdown system is dependent upon the following design variables - Roofing Surface Type, Roof Slope, and Washdown Water Flow Rate. The architect of a new building could change all of these within certain specification limitations; however, if washdown is being considered for an existing structure the surface type and roof slope may be fixed and the washdown water will be the only variable which can be changed in the washdown design to give maximum removal efficiency. Another uncontrollable variable which will contribute to the effectiveness of a roof washdown system in removing fallout is the particle size of the material being removed. The size of the particles falling on a certain building is dependent, of course, on the size of the nuclear detonation, the prevailing wind conditions, and distance from that detonation. Since this variable is uncontrollable the washdown system must be capable of removing any size particle that might be deposited on the roof.

To develop optimum roof washdown designs a full-scale test facility was constructed at the NRD L field station at Camp Parks, Pleasanton, Calif. to determine the relationship of the many variables to particle-removal effectiveness on typical roofing surfaces. Irregularly shaped

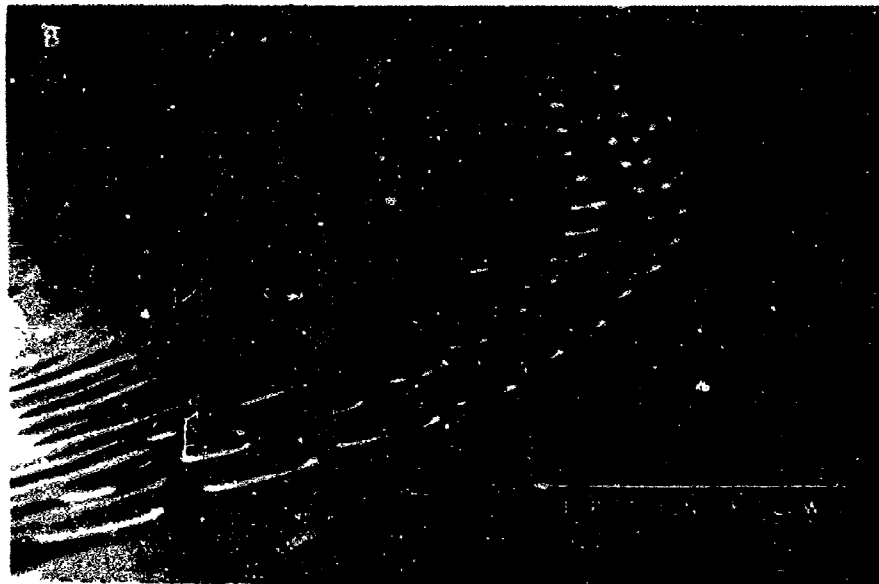
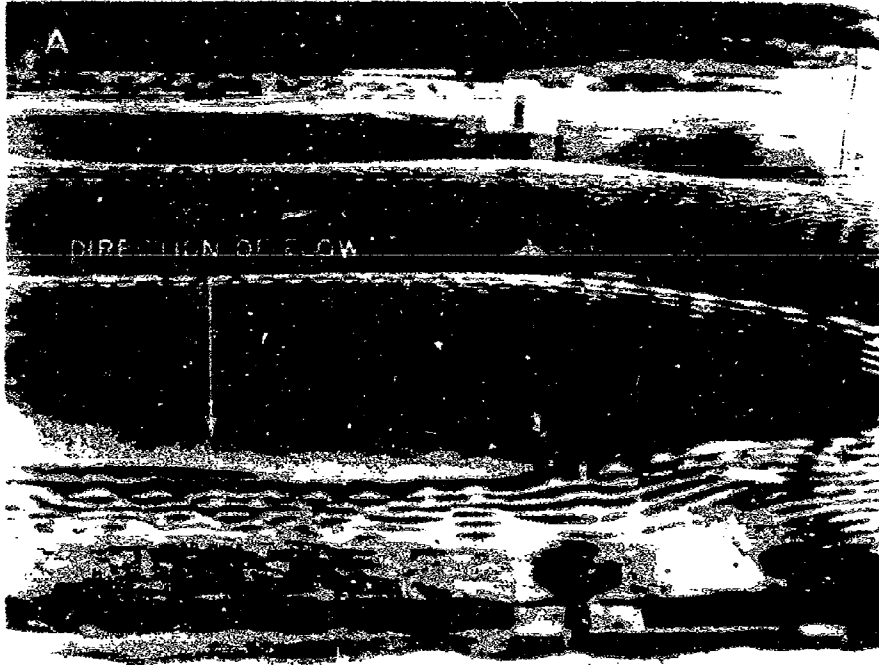

- A. Water Surface Waves on Glass Plane
- B. Typical Wave Front

Fig. 1 Water Surface Waves

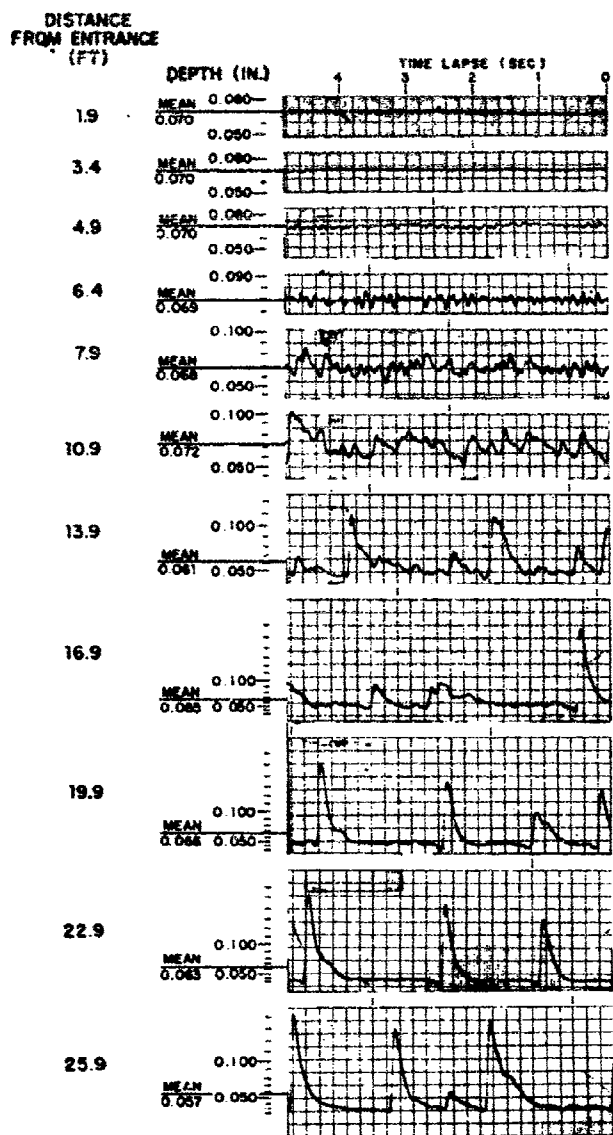

SURFACE - GLASS
 FLOW RATE - 1.83 GPM/FT OF WIDTH
 SLOPE - 0.04

Fig. 2 Water Surface Profiles

river-bed silica (sp. gr. 2.3) with rounded corners was used as the fallout simulant in these studies. This material, which ranged from 44 to 1190 microns in diameter, was separated into five fractions, and a series of tests was conducted on each fraction. Phase I of these tests was conducted using 177 to 350 micron (average - 262 μ) and 350 to 590 micron (average - 450 μ) particles and the results are reported in Ref. 12. Phase II of these tests was conducted using 590 to 1190 micron (average - 910 μ), 88 to 177 micron (average - 112 μ) and 44 to 88 micron (average - 63 μ) particles and the results are reported in Ref. 13.

In all of these tests, flooding nozzles were used as the means of delivering the washdown water onto the test surface. This method of applying water to the test surface was not intended to be the ideal method for use in a roof washdown system, but rather to provide a free-flowing sheet of water over the entire test surface for the study of variables such as roofing surface, roof slope, water-volume requirements, and fallout particle size.

During the course of these studies, consideration was given to other types of nozzles for applying water to the roof. A commercially available rotary lawn-sprinkling nozzle was selected for evaluation and a series of tests was conducted to determine the effectiveness of this nozzle.

1.4 SCOPE OF THIS REPORT

This report includes:

- a. A summary of all previous work on the study of basic design requirements for roof washdown systems and gives a comparison of effectiveness on five typical roofing surfaces.
- b. Evaluation results on a superior method of applying the washdown water to a building roof.
- c. An analysis of roof washdown limitations.
- d. A complete basic roof washdown system for a properly shielded building which could be occupied during a heavy radioactive fallout and continuously, around the clock, after the nuclear detonation.

e. An analysis of reduction in the roof contribution to interior gamma radiation exposure provided by roof washdown on a variety of building sizes.

f. Estimated comparative construction cost of a roof washdown system on a light roof of zero shielding mass to a high mass roof which would give an equivalent interior radiation reduction.

CHAPTER 2

SUMMARY OF ROOF WASHDOWN EXPERIMENTS

2.1 EXPERIMENTAL SET-UP

2.1.1 Roofing Surfaces

The roofing surfaces were mounted on two planes, each 24 ft wide by 48 ft long. Each plane could be tilted to any slope from 0 to 1:4 by a hydraulic system (Fig. 3). Each plane was divided into three sections, forming a total of six areas each 8 x 48 ft to accommodate the following five different roofing materials and one experimental surface:

- Aluminum shingles.
- Composition shingles.
- Roll roofing.
- Tar and gravel roofing.
- Corrugated galvanized steel.
- Fiberglass epoxy laminate - experimental surface.

Specifications for the surfaces are given in references 1 and 2.

2.1.2 Water System

A recirculating water system was used during all tests. The wash down water from the test surfaces ran into settling and filtration tanks. The water was then pumped back to the test surfaces for re-use.

Two types of nozzles were used to deliver the washdown water to the test surfaces. Flooding nozzles were used to establish the water flow requirements on the various roofing surfaces. These nozzles were mounted in a header across the 8 ft width at the top of each test section and provide a continuous sheet flow of water at the test surfaces (Fig. 4). Complete details of the flooding nozzle installation are given in References 12 and 13. Rotary lawn sprinkling nozzles were tested as a more efficient means of distributing the washdown water. These nozzles were suspended in an inverted position (at 12 ft intervals)

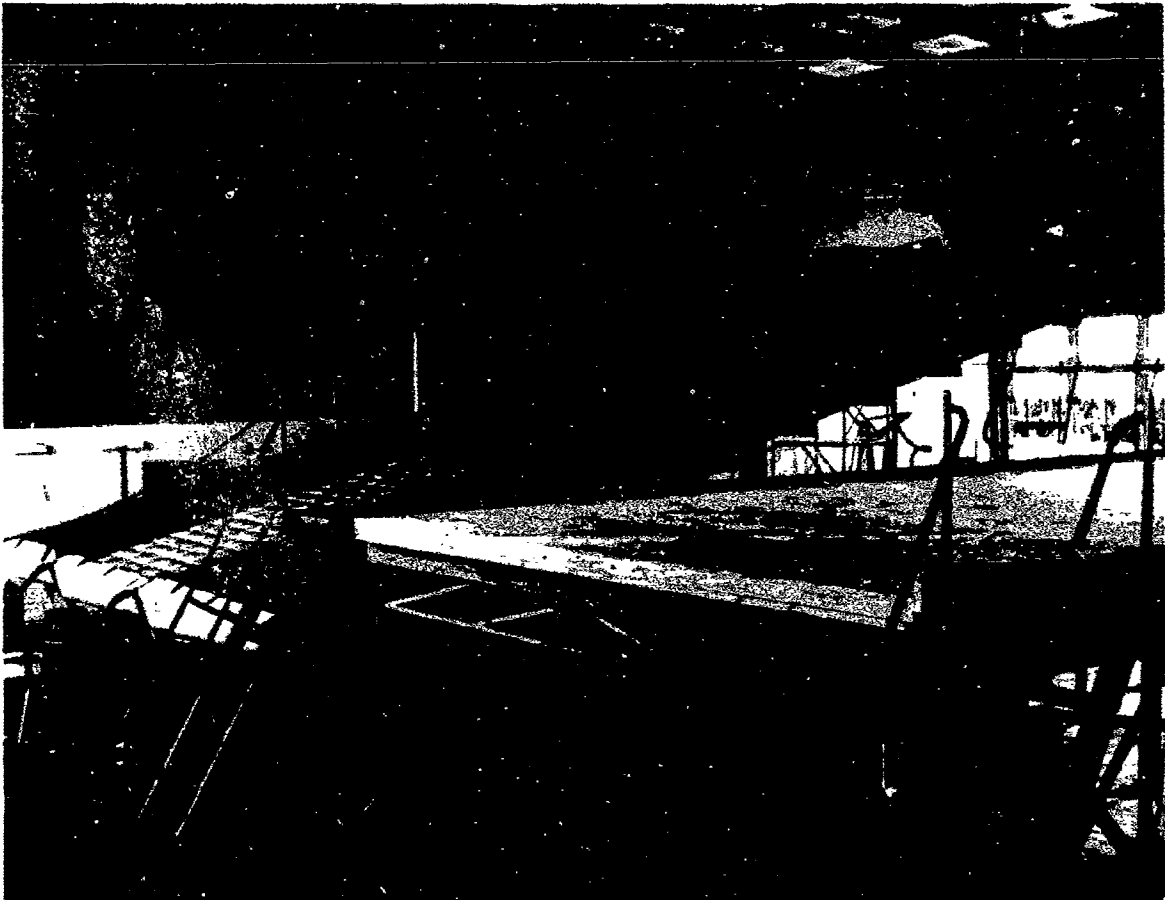

Fig. 3 Test Plane Raised to a 1:4 Slope

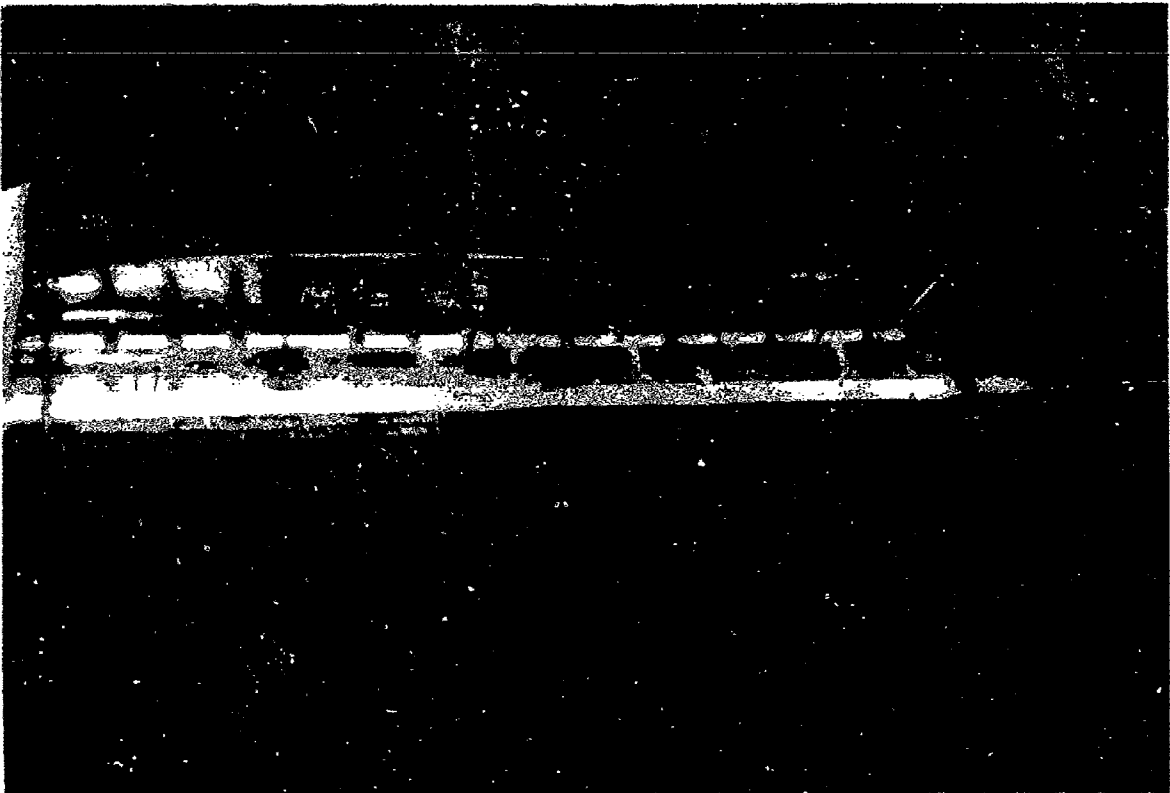

Fig. 4 Flooding Nozzle Manifold. At top of roll roofing test surface.

from a water supply line running lengthwise down the center of each test surface. (Fig. 5) The lowest portion of the nozzles was about 8" above the test surface and were set to oscillate only 90° to each side of the lengthwise centerline.

2.1.3 Fallout Disperser

The fallout disperser system consisted of 18 individual dispersers mounted over each of the two tilt planes, approximately 24 ft above the planes when the planes were in a horizontal position. During operation, continuously metered amounts of the simulant particles were fed to the sand blast nozzles in the individual dispersers, where an air stream picked them up and blasted them against a deflector plate (Fig. 6). The particles then scattered and fell over the 8 by 8-ft area covered by each disperser.

Regulation of the working air pressure and the addition of deflector panels and curtains to the individual dispersers were required to obtain uniform distribution of the particles on the test surfaces.

Further details of the fallout dispersers are given in References 12, 13, and 14.

2.2 EXPERIMENTAL PROCEDURES

In all the washdown-effectiveness studies, a fallout dispersal period of 30 min at a fallout rate of approximately 2 g/min/ft² was used. This rate and the total amount deposited were used because they represent an extreme case which greatly exceeds the maximum that would be expected from a land surface nuclear detonation.

The fallout simulant dispersal was started after the washdown water was turned on, and the test surfaces had been completely wetted. The washdown water flowed during the 30-min dispersal period and for 30 min after the cessation of deposition.

The particles removed from each test surface during this 1-hour period were collected in sieves (Fig. 7). After the washdown period, the sieves were replaced with clean ones, and the residual fallout simulant on the surfaces was removed by manual flushing with a garden hose for 30 min. Longer and repeated flushing removed more material, but the additional percentage removed was only a fraction of a percent after the first 15 min of flushing with the garden hose.

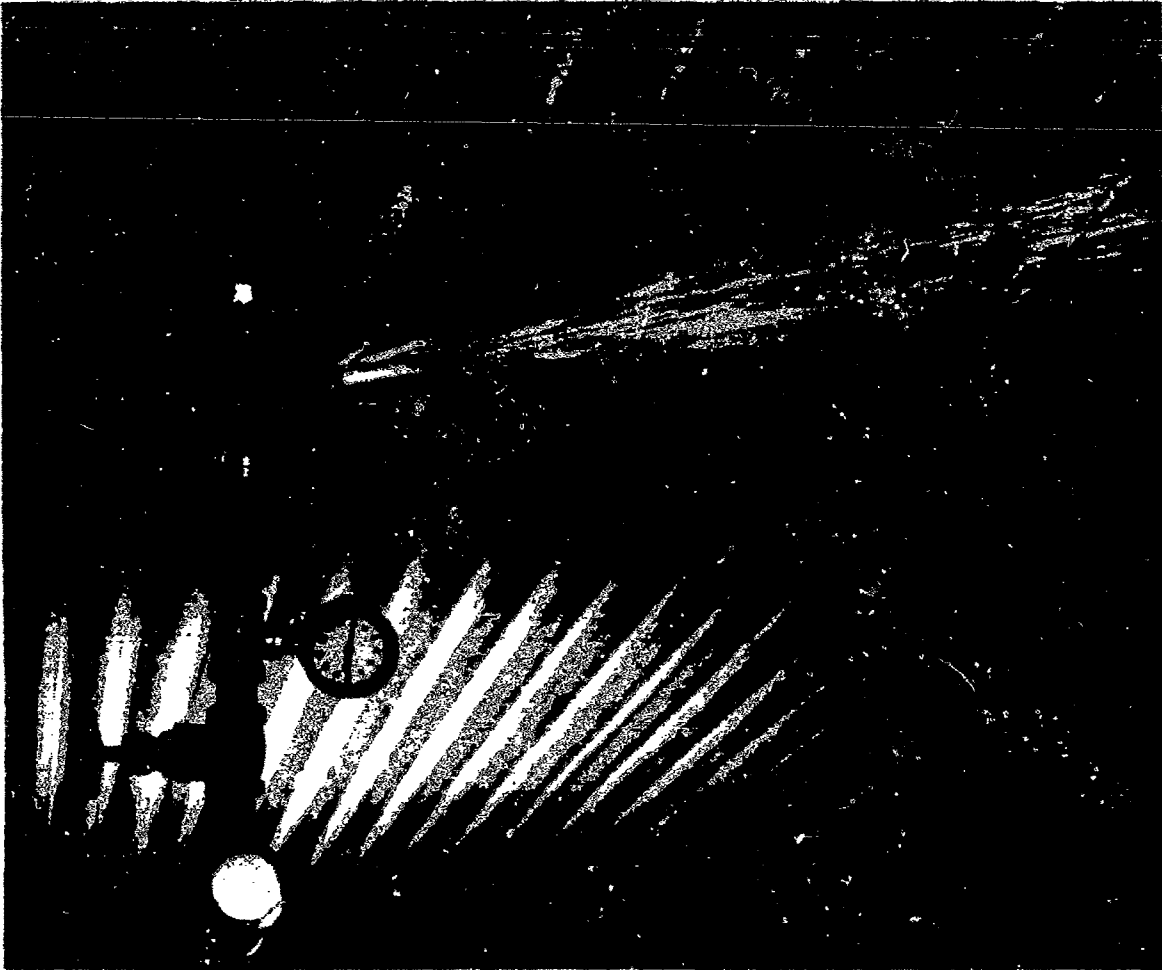

Fig. 5 Rotary Nozzle. Mounted over corrugated roofing surface.

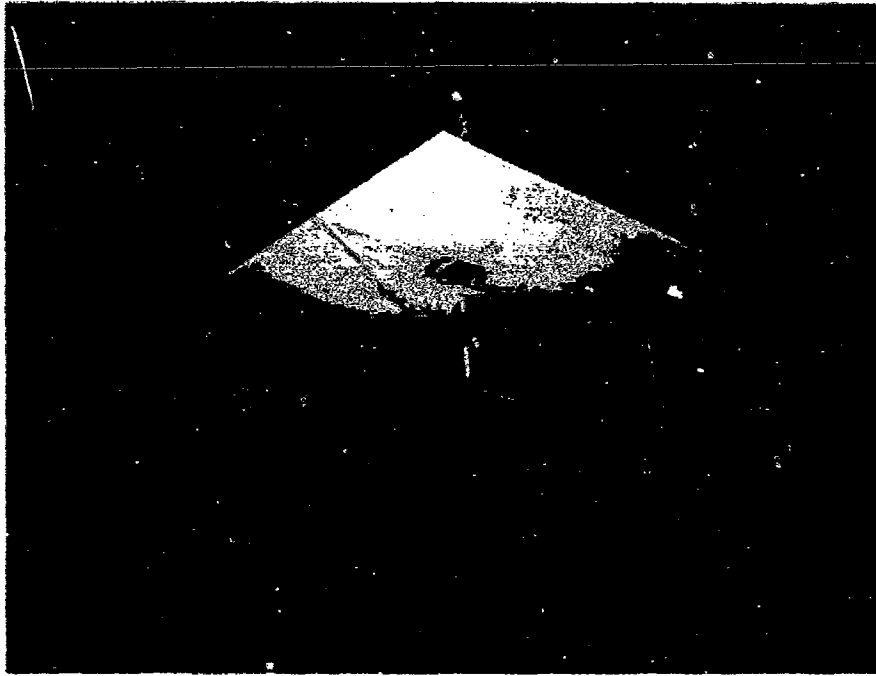

Fig. 6 Individual Fallout Disperser

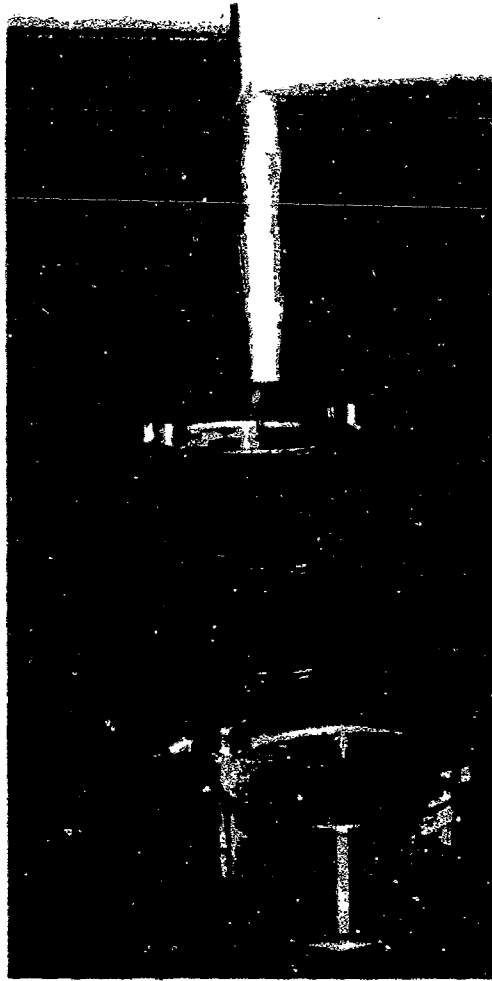

Fig. 7 Sieve Used to Collect Particles Removed from Roof

The simulated fallout particles removed during the washdown period and the residual particles later removed with the garden hose were weighed wet by submerging the sieves and simulated fallout particles in water, allowing them to drain for exactly 10 min, and then weighing them on a platform scale. This technique eliminated the time delay in drying the samples. The wet weight factor of the particles was determined in calibration tests to be 1.25 for the 590 to 1190 μ particles, and 1.27 for the 117 to 350 μ , 88 to 177 μ and the 44 to 88 μ particles.

2.3 RESULTS AND DISCUSSION

2.3.1 Flooding Nozzle Results

The effectiveness of washdown on any roofing surface is dependent upon the roof slope and water flow rate and this effectiveness will vary with the size of the fallout particles deposited on the roof. A roof must be at maximum slope for optimum washdown effectiveness but installation on an existing roof where the slope could not be increased appreciably would require adjustment of other variables to obtain maximum effectiveness. The incorporation of roof washdown into a new building design may permit more freedom in the selection of critical variables such as roof slope, but all buildings will have certain architectural features or basic design requirements that will limit the use of optimum roof slope.

To provide data for the design of a washdown system for both old and new buildings it was necessary to make a thorough study of all the variables involved. A series of washdown tests were conducted on each of 5 different slopes to determine the residual mass with 5 different fallout particle size fractions from 44 to 1190 μ and various water flow rates. From this data presented in references 12 and 13 it is possible to develop design specifications for a variety of roof surfaces under a wide variety of building design limitations.

The effect of fallout particle size on the residual retained on a roof was more pronounced on the corrugated galvanized roofing than any surface tested. Less than 10 % residual could be obtained over a wide range of water flow rates with the 590 to 1190 μ particles, but with the 88 to 177 μ particles the residual mass could not be reduced below 25 to 30 % of the total deposit at all slopes with a water flow as high as 7 gpm/ft of width. The high residual with the fine particles is due to the fallout sticking to the crest of the corrugations, whereas the larger particles roll down into the troughs where the washdown water is flowing.

The smallest effect of fallout particle size was shown on the fiberglass epoxy roof. The 590 to 1190 μ particles required a flow rate of 2 gpm/ft of width on the 1:24 slope to give a residual of 0.5 % as compared to a residual variation of only 0.3 to 0.7 % for the other four sizes. At the 1:4 slope, however, a water flow of only 0.5 gpm/ft of width gave equally low reduction with the largest fallout particles.

On roll roofing, composition shingles and aluminum shingles the 44 to 88 μ particles were the most difficult to remove at all slopes studied and on these three surfaces either the 177 to 350 or 350 to 590 μ particles gave lower residual than any of the other sizes including the 590 to 1190 μ particles. Slope, however, affected the residual much more than particle size.

Corrugated galvanized steel showed the highest percentage residual mass remaining of the 6 surfaces tested with the exception of tar and gravel roofing which is impractical as a roofing surface where wash-down is to be used. This was particularly true with the 88 to 177 μ size particles. A flow of 7 gpm/ft of width was required on the corrugated roof at all three slopes tested (1:8, 1:6 and 1:4) to remove as much as 75 % of the fallout deposit.

Composition shingles surface was the next most difficult to decontaminate. A slope of 1:8 or higher and a water flow rate of at least 4 gpm/ft of width were required to reduce the residual mass to less than 10 %. These same conditions on the aluminum shingles reduced the residual to 5 % or less. A flow of only 2 gpm/ft of width was required on the composition shingles, at a slope of 1:8, to reduce the residual mass of the 590 to 1190 μ particles to less than 10 % as compared to 3 gpm/ft of width for the corrugated surface. At the 1:6 and 1:4 slope a flow of 1.5 and 1.1 gpm/ft of width respectively reduced the residual to 10 % on the composition shingles.

The fiberglass epoxy roofing surface was the easiest surface to decontaminate. At most slopes a flow of only 1/2 gpm/ft of width was required to give better than 90 % removal of the fallout.

The aluminum shingle surface was slightly easier to decontaminate than the roll roofing surface at most conditions but they were both easier to decontaminate than the composition shingle surface.

2.3.2 Rotary Nozzle Results

The removal effectiveness of the rotary nozzles on 5 roofing surfaces is shown in Tables 1 to 5. The values given are percent residual remaining at the conclusion of the washdown period. The values shown in the parentheses in these tables are the percent residual obtained with

the flooding nozzles operating at the same total flow as the rotary nozzles. The rotary nozzles tested are designed to operate at 40 psi. Since the flow of water through the nozzles provides the power for rotation they function more effectively when operated at this pressure. A limited number of tests were conducted, however, at 20 psi to show the comparative removal effectiveness.

The total amount of water delivered by the 4 rotary nozzles on each roofing surface was 15.2 and 21.6 gallons per minute at 20 and 40 psi operating pressure, respectively or 1.9 and 2.7 gallons per minute. These flow rates are the actual volume of water coming off the end of the plane and is the accumulation of the flow from the four nozzles. There was no evidence that the removal was less effective on the upper sections of the roofs where only one nozzle was operating with a flow of 0.48 and 6.8 gallons per minute per foot of width respectively. If the removal effectiveness of the flooding nozzles for these flow rates were used for comparison, the rotary nozzles would look even better. The data presented, however, showed the rotary nozzles to be much more effective than the flooding nozzles on all surfaces. The improvement on the fiberglass laminate, where the residual values were very small, was not as pronounced as on the other surfaces. The rotary nozzles did not remove as much fallout, however, when operated at 20 psi on the 88-177 micron particles as the flooding nozzles. The largest difference in the two nozzles is shown at the 1:24 slope on all surfaces where the rotary nozzles operating at 40 psi are far more superior to the flooding nozzles. In fact, slope becomes a much less important variable with the rotary nozzles. For example, on the roll roofing surface the rotary nozzles gave on 88-177 μ particles a residual of 0.2 % at the 1:4 slope and 1.3 and 1.6 % respectively at 1:8 and 1:6 slope compared to 2.1, 6.8 and 13.0 % respectively with the flooding nozzles. At the 1:24 slope the residual was 4.5 % with the rotary nozzles compared to 33.0 % with the flooding nozzles. The effect of slope was even less with the 590 to 1190 μ particles. The residual was 0.3 % at 1:4, 0.4 % at 1:8, and 3.6 % at 1:24 compared to 1.6, 5.0 and 55.0 % respectively with the flooding nozzles.

The effect of particle size was practically eliminated on the corrugated roof by the rotary nozzles. The 88 to 177 μ particles left only 0.7 % residual compared to 50 % with the flooding nozzles.

The type of water film produced by the rotary nozzles accounts for their effectiveness. They produce a water stream that hits the surface with a force which is effective in jarring particles loose, and as the stream rotates across the surface the water film thins out to produce an abundance of surface waves which keep the particles in motion. Before all the water flows off the surface, the rotary nozzle makes another pass and the process is repeated.

TABLE 1

Washdown Effectiveness of Rotary Nozzle Compared to that of Flooding
Nozzles Giving the Same Flow

Surface: Fiberglass-Epoxy Laminate

Particle Size	Percent Residual						
	1:4	1:8	1:24	1:4	1:8	1:12	1:24
Rotary Nozzles Only							
	Rotary Nozzles at 40 psi Water Flow - 2.7 gpm/ft			Rotary Nozzles at 20 psi Water Flow - 1.9 gpm/ft			
44-88	1.2 (0.7) ^a	0.9 (0.5)	1.4 (-)				
88-177	0.4 (0.3)	0.5 (0.2)	0.9 (2.3)	0.6 (0.3)	0.8 (0.3)	0.7 (0.4)	9.8 (4.2)
350-590	0.3 (0.6)	0.2 (1.0)	0.3 (1.2)	-	-	-	-
590-1190	0.1 (0.3)	0.3 (0.5)	0.4 (2.8)	-	-	-	-
Rotary Nozzles in Combination with Flooding Nozzles (Flooding Nozzles Delivering - 1 gpm/ft)							
	Rotary Nozzles at 40 psi Total Water Flow - 3.7 gpm/ft			Rotary Nozzles at 20 psi Total Water Flow - 2.9 gpm/ft			
88-177	0.5 (0.2)	0.4 (0.2)	0.4 (1.2)	0.6 (0.2)	0.9 (0.2)	0.5 (0.3)	1.8 (2.0)

a. Parentheses indicate values for flooding nozzles giving same total flow.

TABLE 2

Washdown Effectiveness of Rotary Nozzle Compared to that of Flooding
Nozzles Giving the Same Flow

Surface: Roll Roofing

Particle Size	Percent Residual						
	1:4	1:8	1:12	1:24	1:4	1:8	1:24
Rotary Nozzles Only							
	Rotary Nozzles at 40 psi Water Flow - 2.7 gpm/ft				Rotary Nozzles at 20 psi Water Flow - 1.9 gpm/ft		
44-88	3.2 (4.0) ^a	2.3 (8.2)	-	5.5 (-)	-	-	-
88-177	0.2 (2.1)	1.3 (6.8)	1.6 (13.0)	4.5 (33.0)	1.5 (2.7)	3.1 (9.6)	52.7 (41.0)
350-590	0.6 (1.3)	0.3 (5.5)	-	0.6 (12.5)	-	-	-
590-1190	0.3 (1.6)	0.4 (5.0)	-	3.6 (55.0)	-	-	-
Rotary Nozzles in Combination with Flooding Nozzles (Flooding Nozzles Delivering - 1 gpm/ft)							
	Rotary Nozzles at 40 psi Total Water Flow - 3.7 gpm/ft				Rotary Nozzles at 20 psi Total Water Flow - 2.9 gpm/ft		
88-177	0.1 (1.7)	0.3 (4.0)	0.4 (9.5)	1.3 (25.0)	0.9 (2.0)	1.8 (6.0)	24.7 (32.0)

a. Parentheses indicate values for flooding nozzles giving same total flow.

TABLE 3

Washdown Effectiveness of Rotary Nozzle Compared to that of Flooding
Nozzles Giving the Same Flow

Surface: Aluminum Shingles Installation II

Particle Size	Percent Residual					
	1:4	1:6	1:8	1:4	1:6	1:8
Rotary Nozzles Only						
	Rotary Nozzles at 40 psi Water Flow - 2.7 gpm/ft			Rotary Nozzles at 20 psi Water Flow - 1.9 gpm/ft		
44-88	2.6 (4.2) ^a	-	3.1 (-)	-	-	-
88-177	1.9 (3.0)	2.1 (12.0)	6.4 (40.0)	2.4 (4.0)	3.1 (23.0)	8.6 (52.0)
350-590	0.7 (2.5)	-	1.3 (12.0)			
590-1190	1.1 (3.0)	-	1.3 (15.0)			
Rotary Nozzles in Combination with Flooding Nozzles (Flooding Nozzles Delivering - 1 gpm/ft)						
	Rotary Nozzles at 40 psi Total Water Flow - 3.7 gpm/ft			Rotary Nozzles at 20 psi Total Water Flow - 2.9 gpm/ft		
88-177	1.4 (2.4)	1.6 (7.8)	4.8 (28.0)	1.2 (2.9)	1.5 (11.0)	3.1 (38.0)

a. Parentheses indicate values for flooding nozzles giving same total flow.

TABLE 4

Washdown Effectiveness of Rotary Nozzle Compared to that of Flooding
Nozzles Giving the Same Flow

Surface: Composition Shingles Installation II

Particle Size	Percent Residual					
	1:4	1:6	1:8	1:4	1:6	1:8
Rotary Nozzles Only						
	Rotary Nozzles at 40 psi Water Flow - 2.7 gpm/ft			Rotary Nozzles at 20 psi Water Flow - 1.9 gpm/ft		
44-88	9.7 (10.3) ^a	-	11.1 (-)	-	-	-
88-177	3.5 (6.2)	3.9 (-)	5.1 (-)	5.3 (7.8)	6.7 (10.1)	10.3 (19.0)
350-590	3.4 (8.8)	-	7.2 (15.0)	-	-	-
590-1190	3.2 (2.2)	-	5.9 (8.0)	-	-	-
Rotary Nozzles in Combination with Flooding Nozzles (Flooding Nozzles Delivering - 1 gpm/ft)						
	Rotary Nozzles at 40 psi Total Water Flow-3.7 gpm/ft			Rotary Nozzles at 20 psi Total Water Flow-2.9 gpm/ft		
88-177	2.8 (5.6)	2.8 (7.6)	4.2 (12.0)	3.3 (6.0)	3.7 (7.6)	8.7 (14.0)

a. Parentheses indicate values for flooding nozzles giving same total flow.

TABLE 5

Washdown Effectiveness of Rotary Nozzle Compared to that of Flooding
Nozzles Giving the Same Flow

Surface: Corrugated Galvanized Steel

Particle Size	Percent Residual			
	1:4	1:8	1:4	1:8
Rotary Nozzles Only				
	Rotary Nozzles at 40 psi Water Flow - 2.7 gpm/ft		Rotary Nozzles at 20 psi Water Flow - 1.9 gpm/ft	
44-88	2.8 (57.0) ^a	0.8 (-)	-	-
88-177	1.3 (40.0)	0.7 (50.0)	0.5 (44.0)	0.8 (55.0)
350-590	0.3 (-)	0.4 (-)	-	-
590-1190	0.5 (5.2)	0.3 (10.1)	-	-
Rotary Nozzles in Combination with Flooding Nozzles (Flooding Nozzles Delivering - 1 gpm/ft)				
	Rotary Nozzles at 40 psi Total Water Flow - 3.7 gpm/ft		Rotary Nozzles at 20 psi Total Water Flow - 2.9 gpm/ft	
88-177	1.0 (35.0)	0.4 (44.0)	0.7 (38.0)	0.6 (48.0)

a. Parentheses indicate values for flooding nozzles giving same total flow.

There is the possibility that fallout particles will lodge in the rotary nozzles, thus preventing rotation. A protective cover was designed for the nozzles and an effective roof washdown system built around these nozzles should have a low flow admitted at the crest of the roof with flooding nozzles to assure transport in the event that one of the rotary nozzles will fail to rotate. A test was conducted on the 88 to 177 micron particles with a combination of rotary and flooding nozzles. A low flow of only 1 gpm per ft of width was delivered by the flooding nozzles in these tests. On all 5 surfaces the residual showed a greater reduction with the combination of nozzles.

2.3.3 Effect of Deposition on Dry Surfaces vs Wetted Surfaces

In all of these studies the washdown water was turned on prior to the initiation of fallout. It was originally planned to study the effect of removal from dry surfaces vs wetted surfaces.* It was found, however, that approximately the same residual was obtained when the washdown was turned on after the fallout had ceased and most of the material was removed in the first 15 minutes of washdown as shown in Table 6.

Since it is desirable to remove the fallout from a roof as soon as possible, particularly at early times after the nuclear detonation, operation personnel should be instructed to turn on the washdown system prior to the arrival of fallout or shortly after fallout starts. For a very small additional expense a radiation alarm system or an automatic electric pump switch operated by a radiation sensing device could be installed.

2.3.4 Effect of Obstructions on Washdown Effectiveness

In the early studies of the transport of particulate matter by water films (Reference 6) it was observed that objects placed in the water stream produced eddy currents which actually caused particles to move upstream and collect behind the objects. It was also observed that large particles affect the transport of smaller particles as shown in Fig. 8. In this particular case the spherical particle was stationary and the smaller particles started collecting around it and here again the eddy currents caused the particles passing nearby to be pulled upstream and to be deposited behind the larger particle.

The proper placement of obstructions on a roof, such as skylights and vents, should be considered in the design of an efficient washdown system.

* R. H. Heiskell, R. H. Black, H. L. Burge. Transport of Contaminant by Water Film Studies. U. S. Naval Radiological Defense Laboratory Reviews and Lectures No. 68, February 1958.

TABLE 6

Washdown Turned on After Fallout was Deposited
 Fallout Particle Size - 88 to 177 μ
 Fallout Disperser on for 15 minutes at approx 2 grams/min/ft²

Surface	Washdown Water Flow Rate gpm/ft of width	% of Total Removal in 1st 15 min of Washdown	% of Total Removal in 2nd 15 min of Washdown
Aluminum Shingles	4.0	97.5	2.5
Composition Shingles	4.0	98.3	1.7
Fiberglass Laminate	2.0	99.8	0.2
Roll Roofing	4.0	99.5	0.5
Corrugated	4.0	99.6	0.4



Fig. 8 Build-Up of Small Particles Around Larger Spherical Particles.

CHAPTER 3

ROOF WASHDOWN DESIGN

3.1 WASHDOWN LIMITATIONS

Reduction of a building's interior gamma radiation by roof washdown can be effective only when the roof contamination is the dominant source of gamma radiation. Adequate protection can be provided in a building with high-mass walls and light roof structure by removing the roof contamination with an effective washdown system. However, washdown would be of little value on a building with light wall construction when the occupants are required to remain in close proximity to the walls. The protection furnished by such a building structure may be adequate if the occupants are confined to the center of the building which has a large floor area. The majority of buildings where protection is needed have a floor area much smaller than would be required to provide adequate protection by distance. Therefore, heavily shielded walls would be necessary.

3.2 BASIC DESIGN

The roof washdown experiments (described in Chapter 2) provided the following basic design information that will assure effective removal of radioactive fallout particles from building roofs:

1. Rotary lawn sprinklers are the most effective type of nozzle tested to date.
2. The rotary sprinklers should be spaced 10 ft apart across the roof and in rows 12 ft apart down the roof, from crest to trough. Each nozzle should be operated at a pressure of approximately 40 psi to deliver about 5.4 gpm.
3. Flooding-type nozzles should be installed across the width of the roof at the crest to deliver 1 gallon of water per ft of width.

The sheet flow produced by these nozzles will act as insurance in the event that a rotary nozzle fails to rotate.

4. A laminated fiberglass epoxy roof is the most desirable surface for a washdown system.

5. Roll roofing is the second best roofing surface for a roof equipped with washdown.

6. A roof slope of 1:24 is adequate for the rotary nozzles on either laminated fiberglass or roll roofing.

7. The building should have a parapet to minimize water loss to the wind.

8. A recirculating water system is desirable and will make the system independent of the regular water supply, which might be interrupted by a nuclear detonation.

9. A shielded tank must be provided to contain the radioactive contamination washed from the roof.

A building design incorporating these design features is shown in Figures 9 and 10. This is a complete basic design for a radiologically protected building with a reduction factor of 350 for the 18 inch thick concrete shielding walls. This particular building design is similar to that of the Federal Aviation Agency buildings at Fremont, Calif.; Fort Worth, Texas; and Jacksonville, Florida. (NRDL was consulted in the design of the roof washdown spray system for these buildings.) The 30 ft high walls reduce the skyshine and transit exposure contributions. The exposure contribution from the roof without the washdown operating is 78 % of the total interior exposure as described in Section 3.3 below.

No experimental data is presently available on the transport of large masses of fallout particles with large volumes of water in drainage gutters and pipes. The FAA radiologically-protected building at Fremont, Calif., for example, was designed with the aid of standard engineering data, but when the washdown system was tested with a deposit of simulated fallout on the roof the drains were found to be inadequate to handle the flow. It was necessary to increase the number of drain lines.

Washdown can be used to advantage on existing buildings if certain requirements are met.

1. The building must have high mass walls or be of such design that the mass thickness can be increased easily and economically, or be large enough that the occupants could be confined to a center section of the building after a nuclear attack.

The mass thickness of the Air Force Radar Station at Alameda, Calif. was increased by putting up walls outside the existing walls and filling the 16 inch cavity between with soil. A false roof was then installed to give proper slope and washdown was installed. These design features were based on data supplied to the Air Force* and private conferences with Air Force Engineers in San Francisco.

2. The roof must have a slope of at least 1:8 if the roofing surface is composition shingles, aluminum shingles, or corrugated metal.

3. If the roofing surface is tar and gravel or is similarly rough, the surface must be removed and replaced with a surface comparable in smoothness to that of the other surfaces tested in these roof washdown experiments.

4. The drain gutters on the building must be of sufficient size and slope to handle the volume of water required and the mass of fallout particles.

3.3 REDUCTION OF RADIATION EXPOSURE

The sources which contribute to the radiation exposure of personnel inside a building at some distance from a nuclear detonation are (1) ground contribution (direct radiation from fallout on the ground surrounding the building), (2) roof contribution (direct radiation from fallout on the roof), (3) skyshine (an effect produced by the scattering of radiation by the air) and (4) transit exposure (the exposure from the fallout cloud as it passes near the building).

The exposure can be reduced by means of shielding in the walls or roof, a roof washdown system, or a combination of the two. The importance of shielding in the exterior walls of a building, which reduces mainly the ground contribution to the interior, is shown in Table 7. The data are taken from Ref. 15 and are based on the assumption that the detector is 3 ft above the floor in the center of the building.

The roof contribution, skyshine, and transit exposure all can be reduced by shielding with a concrete roof. The effectiveness of this method depends upon the thickness of the roof, which makes it less attractive since a concrete roof is comparatively expensive.

* R. H. Heiskell. Air Force Conference on AC&W Fallout Protection. U. S. Naval Radiological Defense Laboratory Trip Report, 933, RHH, 17 May 1963.

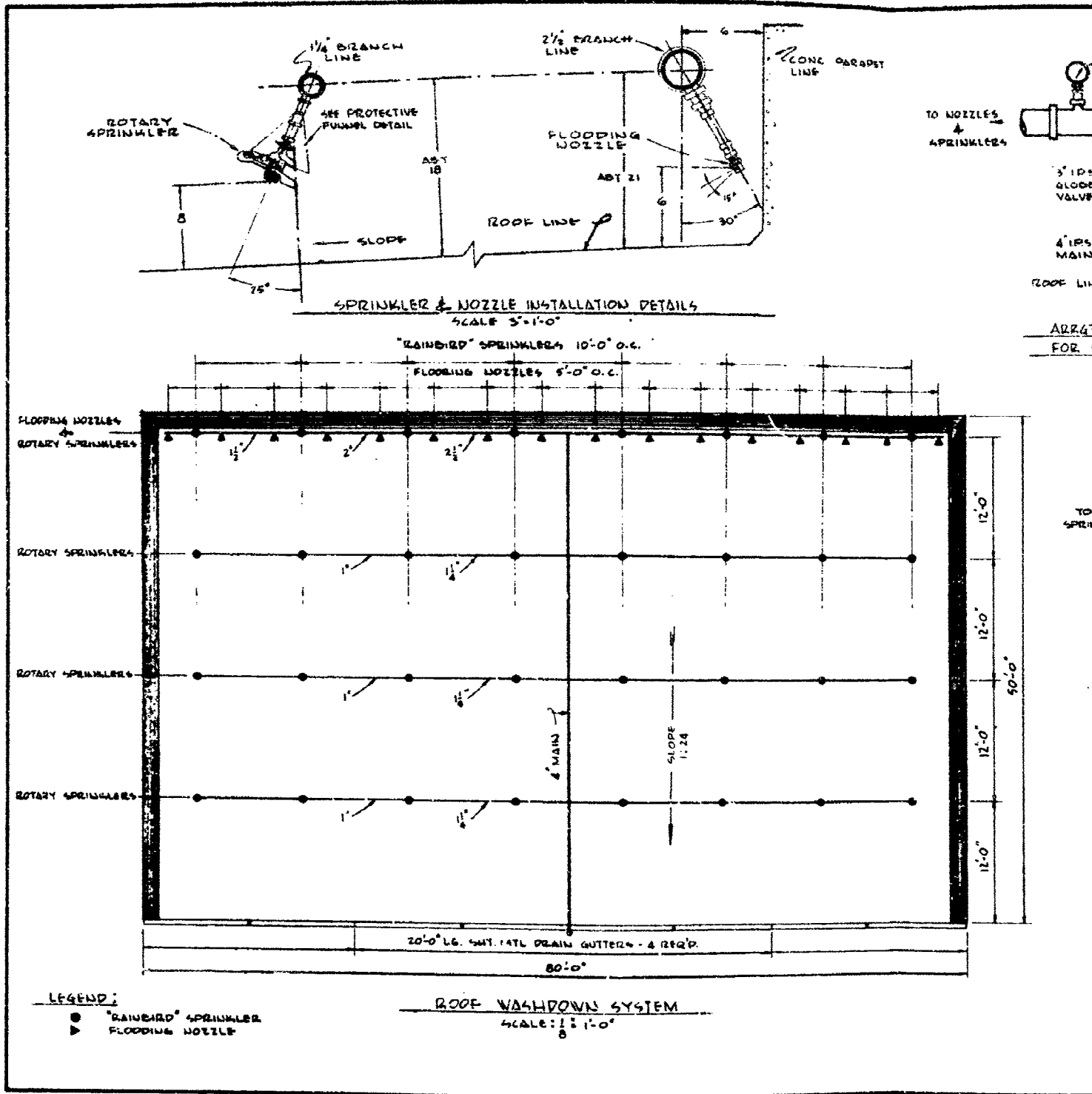
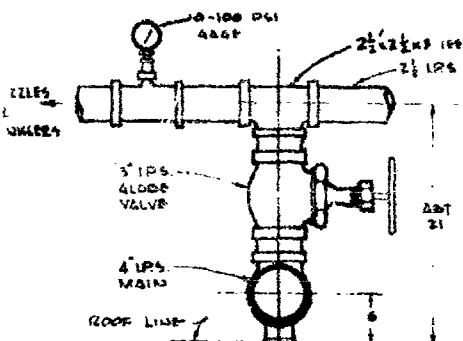
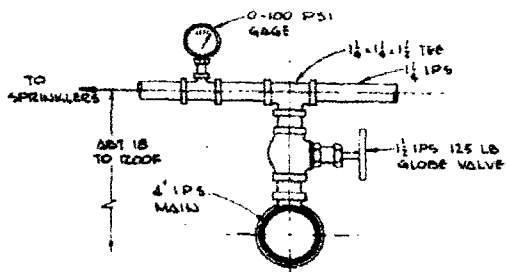

Fig. 9 Basic Washdown System For 4000 sq Protected Building (Dwg CT-64-563)



ARRGT of 2 1/2 IPS BRANCH FEEDER
FOR FLOODING NOZZLES & ROTARY
SPRINKLERS
SCALE: 2"-1'-0"

NOZZLE &
SPRINKLER
FEEDER



TYP ARRGT of 1 1/2 IPS BRANCH
FEEDER FOR ROTARY SPRINKLER
SCALE: 2"-1'-0"

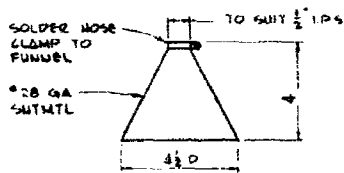

PROTECTIVE FUNNEL
DETAIL
SCALE: 4"-1'-0"

LIST OF MATERIAL				
QUANTITIES SHOWN ARE FOR ONE INSTALLATION				
NO	NAME	NO REQ	MATL	REMARKS
1	ROTARY SPRINKLER	32	BRASS ORIFICE	RANGE 2" 25
2	FLOODING NOZZLE	16	BRASS ORIFICE	2" 25
3	GLOBE VALVE	1	ATL 5" IPS	125 LB
4	GLOBE VALVE	2	4" IPS	125 LB
5	PRESSURE GAGE	4	0-100 PSI	WATER TYPE
6	MAIN PIPE	40	4" IPS	4 GALV. CL. 40
7	FEEDER PIPING	20	2 1/2" IPS	
8	FEEDER PIPING	20	2" IPS	
9	FEEDER PIPING	30	2" IPS	
10	FEEDER PIPING	60	1 1/2" IPS	
11	FEEDER PIPING	120	1" IPS	
12	PROTECT FUNNELS	32	4" DIA	#28 GA G-1
13	TEE	1	4x4x3	125 LB GALV
14	TEE	1	3x3x3	
15	NIPPLES	2	5" IPS	
16	TEE	8	2 1/2x2 1/2	
17	REDUCER	10	1" - 2"	
18	TEE	4	2x2x1/2	
19	TEE	2	2x1 1/2x1/2	
20	TEE	2	2 1/2x2x1/2	
21	TEE	8	1 1/2x1 1/2	
22	TEE	3	4x4x1	
23	TEE	5	1 1/2x1 1/2x1/2	
24	NIPPLES	6	1 1/2" IPS	
25	TEE	6	1 1/2x1 1/2	
26	TEE	6	1 1/2x1 1/2	
27	TEE	10	1x1x1/2	
28	PLUG	6	1" IPS	
29	PLUG	2	1 1/2" IPS	

NOTES:

- SEE SHT 2 FOR BALANCE OF SYSTEM: DRAINS, FILTER TANK, ETC.
- ALL PIPING TO BE PROPERLY MOUNTED ON SUPPORTS.

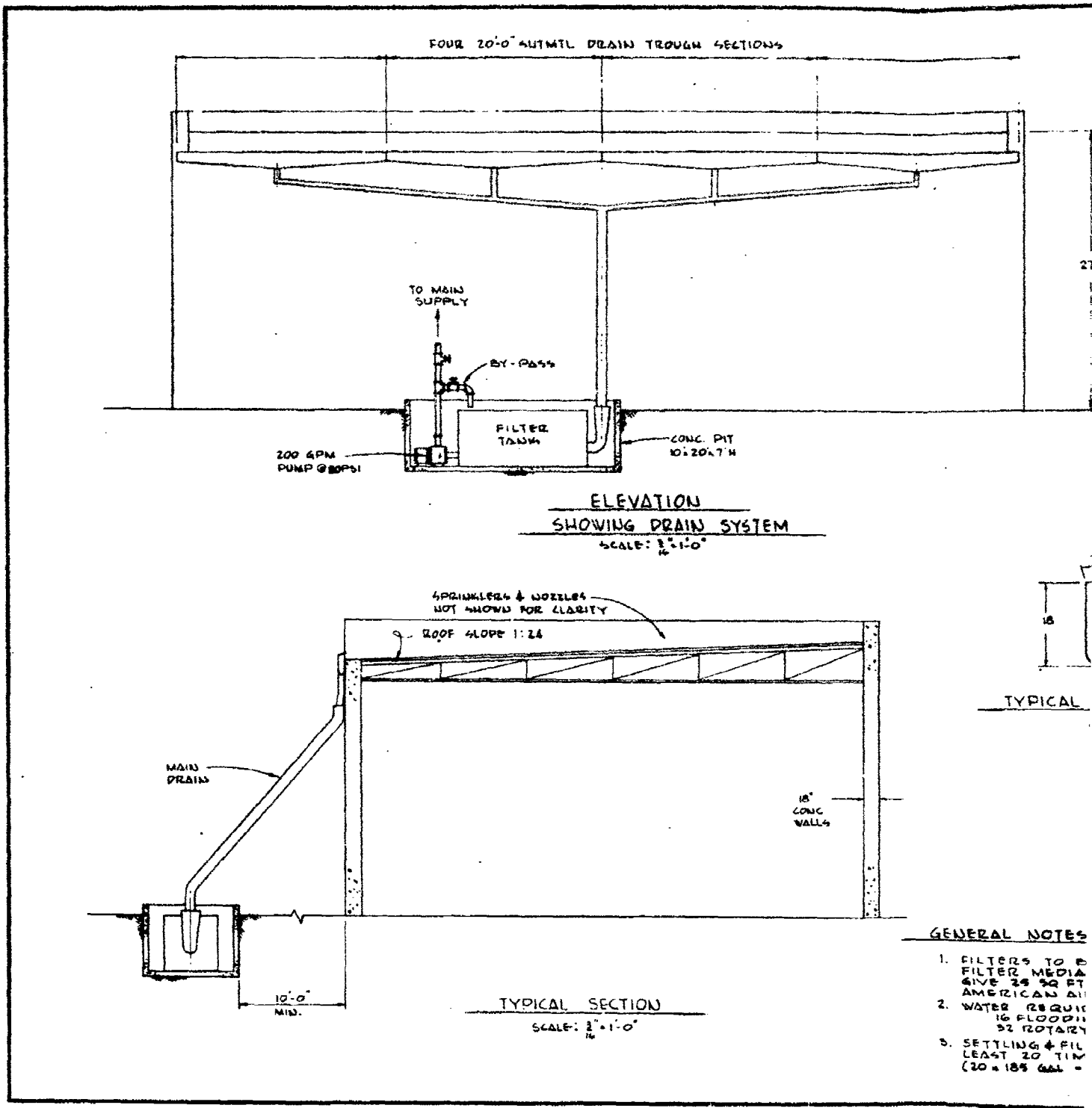
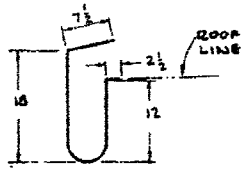
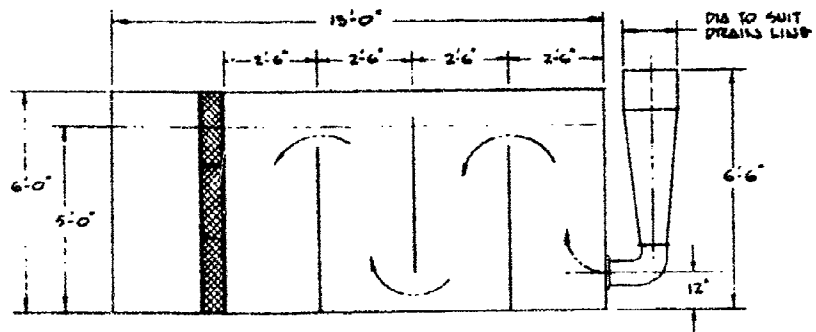
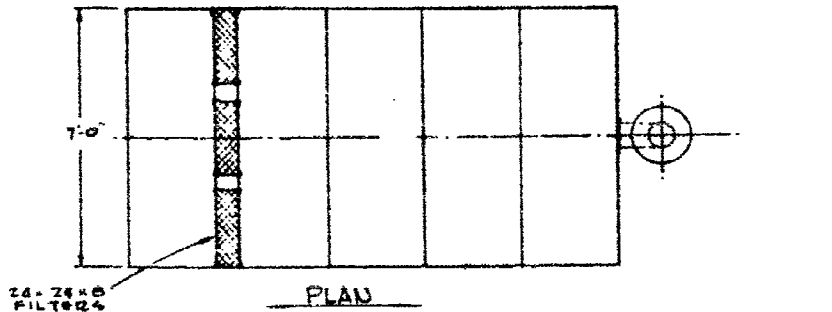
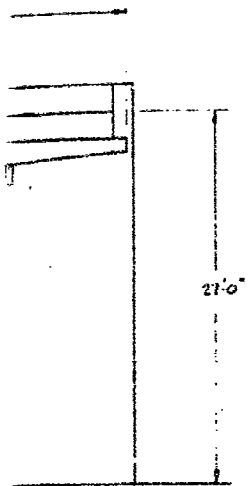

Fig. 10 Basic Washdown System For 4(Protected Building (Dwg CT-

A



TYPICAL TROUGH SECTION
SCALE: 1/2" = 1'-0"

ELEV
ARRGT. OF SETTLING AND
FILTRATION TANK
SCALE: 1/4" = 1'-0"

GENERAL NOTES:

1. FILTERS TO BE 24" x 24" x 6" WITH 3/16" FIBREGLASS FILTER MEDIA FOLDED IN ACCORDION PLEAT TO GIVE 28 SQ FT OF SURFACE. SIMILAR OR EQUAL TO AMERICAN AIR FILTER CO., AIRMAT
2. WATER REQUIREMENTS:
 16 FLOODING NOZZLES @ 6 GPM _____ 96 GPM
 32 ROTARY LAWN SPRINKLERS @ 27 GPM _____ 864 GPM
3. SETTLING & FILTRATION TANK CAPACITY TO BE AT LEAST 20 TIMES TOTAL FLOW RATE PER MINUTE (20 x 189 GAL = 3780 GAL)

Water System For 4000 sq. ft. Radiologically Contaminated Building (Dwg CT-64-563, Sheet 2 of 2)

The roof washdown system can reduce the roof contribution, but cannot reduce the skyshine or transit exposure. However, since only a minimum thickness of roof is required to support the washdown system, the reduced cost of the roof and building is one of the main reasons for the use of the washdown.

Table 8 gives the fraction of the free-field exposure for each of the contributing factors for buildings of three different sizes. These buildings are assumed to be windowless and to have a roof of negligible mass thickness so the total roof contribution is 71 to 79 % of the total interior exposure. The buildings have 18-inch-thick concrete walls up to the roof, which is 30 ft above the ground floor. The skyshine contribution as given in Ref. 15 is 0.15 of the roof contribution, and the exterior transit exposure is assumed to be 3 % of the total free-field exposure, as discussed in Appendix A.

Table 9 gives the total accumulated exposure for personnel in the center of the buildings without the washdown system, and with a washdown system that reduces the roof contamination to 10, 5 and 2 % of the total amount deposited. The free-field accumulated exposure is to be 5,000 r, and could be accumulated during the period from 1 hr to 30 days after detonation time in an area where the free-field exposure rate at H + 1 is about 1500 r/hr at 1 hr. It is assumed that reclamation operations outside the buildings will reduce the radiation field after 30 days so the buildings can be occupied without further concern.

This table shows that the roof contribution increases with an increase of the building size, and the effectiveness of roof washdown increases accordingly. In the hypothetical case where the free-field exposure rate is 1500 r/hr at 1 hr, an interior exposure of only 235 r would be accumulated in a 1000-ft² building without washdown, so a washdown system is desirable but not required. However, washdown would be required on a building of this size if an initial exposure rate of 4,000 to 5,000 r/hr at 1 hr were anticipated.

If the larger buildings are located in an area where a radiation field of 1500 r/hr at 1 hr is anticipated, roof washdown is essential on both the 4000 and 10,000 ft² buildings in order to reduce the interior exposure to a safe level.

TABLE 7

Ground Contribution Through Walls as Fraction of Free Field-Exposure

Wall Thickness (inches of concrete)	Mass Thickness (lb/ft ²)	Fraction of Free-Field Exposure ^a		
		Floor Area of Building		
		1000 ft ² (25 x 40 ft)	4000 ft ² (50 x 80 ft)	10,000 ft ² (60 x 170 ft)
0	0	0.6	0.44	0.32
6	75	0.094	0.06	0.04
12	150	0.024	0.015	0.0095
18	225	0.0045	0.0028	0.0019

a. Free-field exposure is the exposure in a field free of buildings or other shieldings.

TABLE 8

Factors Contributing to the Interior Exposure of Windowless Buildings with 30 ft High, 18-inch-thick Concrete Walls

	Fraction of Free-Field Exposure ^a		
	Floor Area of Building		
	1000 ft ² (25 x 40 ft)	4000 ft ² (50 x 80 ft)	10,000 ft ² (60 x 170 ft)
Roof Contribution ^b	0.033	0.0960	0.1500
Skyshine	0.005	0.0144	0.0225
Ground Contribution	0.0045	0.0028	0.0019
Transit Dose	<u>0.0043</u>	<u>0.0102</u>	<u>0.0158</u>
Total Contribution ^c	0.0468	0.1234	0.1902
Total Roof Contribution in Percent of Total Interior Dose	71 %	78 %	79 %

a. The methods of calculation are given in Appendix A.

b. Roof is assumed to have zero mass thickness, and no allowance is made for partitions or intermediate floors.

c. Detector is located 3 ft above the center of the ground floor.

TABLE 9

Total Accumulated Exposure to Personnel in the Center of the Ground Floor of Windowless Buildings*, Based on an Accumulated Free-Field Exposure of 5,000 r.

	Fraction of Free-Field Contribution	Total Accumulated Exposure in r			
		Without Washdown	Percent Residual, with Washdown		
			10	5	2
<u>1,000 ft² Floor Area</u>					
Roof Contribution	0.033	165	17	8	3
Skyshine	0.005	25	25	25	25
Wall Contribution	0.0045	23	23	23	23
Transit	0.0043	22	22	22	22
Total	0.0468	235	97	78	73
<u>4,000 ft² Floor Area</u>					
Roof Contribution	0.096	480	48	24	10
Skyshine	0.0144	72	72	72	72
Wall Contribution	0.0028	14	14	14	14
Transit	0.0102	51	51	51	51
Total	0.1234	617	185	161	147
<u>10,000 ft² Floor Area</u>					
Roof Contribution	0.15	750	75	38	15
Skyshine	0.0225	113	113	113	113
Wall Contribution	0.0019	10	10	10	10
Transit	0.0158	79	79	79	79
Total	0.1902	952	277	240	217

*Buildings have 18 inch concrete walls (mass thickness of 225 lbs/ft²) up to the roofs, which are 30 ft above the ground floor level.

3.4 COST OF ROOF WASHDOWN VS CONCRETE ROOFS

The primary purpose of roof washdown is to reduce the exposure received in a building interior for a minimum expenditure. A concrete roof which gives an equivalent reduction in radiation exposure rate is used for cost comparison with the roof washdown system. A concrete roof approximately 6 inches thick is required to provide a 95 % reduction of the roof contribution and approximately 12 inches of concrete is required to provide 98 % reduction (Ref. 1).

The installation cost of a roof washdown system on a hypothetical building design has been calculated for buildings of three sizes, 1,000, 4,000 and 10,000 ft². These buildings are single-story structures with 18-inch-thick concrete walls up to the roof which is 30 ft above the floor. This design is similar to that of Federal Aviation Agency buildings at Fremont, Calif.; Fort Worth, Texas; and Jacksonville, Florida. Only two types of roofing surfaces, fiberglass epoxy laminate and roll roofing are considered in these comparisons.

Table 10 gives the cost for installation of a roof washdown system on existing buildings with 1,000, 4,000, and 10,000 ft². These figures include the cost of the entire system, consisting of piping, nozzles, water supply, settling and filtration tank, concrete pit for supply tank, drainage system, pump, and installation. A summary of the cost of the various components is given in Appendix B.

The cost of a new roof structure prior to installation of a washdown system is given in Table 11. The roof structure considered here is of light-weight, minimum construction. Two types of roofing surfaces are considered, fiberglass laminate and roll roofing. The fiberglass epoxy laminate is recommended as the ideal roofing surface to be used with roof washdown; it will provide a long-life, trouble-free roof. The roll roofing is presented as the best of the commercial surfacings of low initial cost.

The fiberglass laminated roofing is about 50 % more expensive than roll roofing on the 1000 and 4000-ft² building, but only about 30 % higher on the 10,000-ft² building. The cost figure on the 10,000-ft² building is based on a conservative figure of \$1.10/ft² for the fiberglass epoxy laminate installed on a plywood sub-base. The cost of installing the fiberglass laminate should actually go down to 75 or 80 cents/ft² on a roof of this size, which would make it only 18 % higher. Therefore it is highly recommended that the fiberglass epoxy laminate be used because of the increased washdown effectiveness, durability, and low maintenance cost of this type of roof.

TABLE 10

Cost of Installing a Roof Washdown System on an Existing Roof

	Building Size (ft ²)		
	1,000 (25 x 40 ft)	4,000 (50 x 80 ft)	10,200 (60 x 170 ft)
Total Cost	\$2805	\$6702	\$14,175
Cost per sq. ft.	\$2.80	\$1.68	\$1.42

TABLE 11

Comparison of Roofing Material Cost

	Building Size (ft ²)		
	1000 (25 x 40 ft)	4000 (50 x 80 ft)	10,200 (60 x 170 ft)
Fiberglass Epoxy Laminate on Structural Steel Trusses and Wood Roof			
Total Cost	\$3170	\$10,516	\$25,560
Cost per sq. ft.	\$3.17	\$2.63	\$2.56
Roll Roofing on Structural Steel Trusses and Wood Roof			
Total Cost	\$2060	\$6996	\$19,356
Cost per sq. ft.	\$2.06	\$1.75	\$1.94

Table 12 gives the comparative costs for 6-inch- and 12-inch-thick concrete roof slabs for the 4000 ft² building which are approximately equivalent in radiation dose reduction to 95- and 98-%-effective roof washdown systems respectively.

This table shows that roof washdown installed on a fiberglass epoxy laminated roof will cost only 45 % of the cost of a 12-inch concrete roof that would give an equivalent reduction in roof contribution to interior exposure.

3.5 LIMITATION OF ESTIMATES

The estimates given in this study are based strictly on an "open bay" type building wherein the roof section is completely cantilevered from outside wall to outside wall. It is to be noted appreciable savings could be effected, particularly in the larger-size buildings, by dividing a building into two or even three bays. The heavy structural requirements based on long-span supports could then be reduced considerably.

All estimates are subject to scrutiny, as the local conditions of labor and material costs vary over a range of 10 to 25 %. The estimates quoted for this report reflect the comparatively high values of the San Francisco area.

Costs are further based on the latest practice of using the prefabricated lightweight long-span joists with the Warren trussing. For standard structural-steel practices, costs should be increased by 50 % based on a comparison of steel weights, the factor most used in estimating steel work.

The washdown system will also vary in cost, as the gutter design is based on the sizes used in the roof washdown studies. Inasmuch as no studies have been made regarding the sizing of gutters and piping, the estimates for the drainage system should be regarded as only preliminary, subject to experimental corroboration.

TABLE 12

Comparative Costs of Concrete Roof and Roof Washdown on Light Roof Structure for a 4000 ft² (50 x 80 ft) Building

Protective Roof	95 % Reduction	98 % Reduction
<u>Concrete, with Tar and Gravel Roofing</u>	(6-inch Thickness)	(12-inch Thickness)
Total Cost	\$24,075	\$38,490
Cost per sq ft	\$6.02	\$9.62
<u>Washdown on Roll Roofing Surface</u>		
Total Cost	\$13,698	98 % reduction not likely with roll roofing
Cost per sq ft	\$3.43	
% saved	43	
<u>Washdown on Fiberglass Surface</u>		
Total Cost	98 % reduction obtained with this surface	\$17,218
Cost per sq ft		\$4.31
% saved		55

CHAPTER 4

CONCLUSIONS AND RECOMMENDATIONS

4.1 CONCLUSIONS

Roof washdown is of value as a radiological countermeasure only on buildings with heavily shielded walls or where the occupants are confined to the center of a building with a very large floor area. No benefit would be gained from the installation of a roof washdown system on a civilian building such as a home with a thin wall structure. Roof washdown therefore, is of value only in reducing building construction cost by eliminating the need for high mass concrete roofs. A complete recirculating roof washdown system installed on a fiberglass epoxy laminated roof which will reduce the roof contamination to less than 1 % will cost only 45 % of the cost of a 12 inch concrete roof that would give a similar reduction (98 %) in roof contribution to interior exposure.

Corrugated galvanized steel showed the highest percentage residual mass remaining of the 6 surfaces tested using the flooding type nozzles, particularly with the 88 to 177 μ size particles. A water flow of 7 gpm/ft of width was required at all three slopes tested to reduce the residual to as low as 25 %.

Composition shingle was the next most difficult surface to decontaminate with the system fitted with flooding nozzles. A slope of 1:8 or higher and a water flow rate of at least 4 gpm/ft of width were required to reduce the residual mass to less than 10 %. These same conditions on the aluminum shingles reduced the residual to 5 % or less.

The fiberglass epoxy laminated roof was the easiest surface to decontaminate. At most slopes a flow from the flooding nozzles of only 0.5 gpm/ft of width was required to give better than 90 % removal of the fallout.

The aluminum shingle surface was slightly easier to decontaminate than the roll roofing surface at most conditions but they were both easier to decontaminate than the composition shingle surface.

The effect of fallout particle size on the residual retained on a roof was more pronounced on the corrugated galvanized roofing than any other surface tested. The high residual with the smaller particles is due to the fallout's sticking to the crest of the corrugations, whereas the larger particles roll down into the trough where the washdown waste is flowing.

The smallest effect of fallout particles on removal rate with the flooding nozzles was shown on the fiberglass epoxy laminated roof.

Slope affected the residual on all surfaces with the flooding nozzles much more than particle size did.

The rotary lawn type sprinklers were much more effective than the flooding nozzles on all surfaces. The largest difference in the two nozzles is shown at the 1:24 slope on all surfaces where the rotary nozzles are far superior. Slope becomes a much less important variable with the rotary nozzles.

The effect of particle size on washdown efficiency was practically eliminated by the rotary nozzles on the corrugated roof.

Rotary type lawn sprinklers are effective in removing 95 to 98 % of the fallout from all five of the standard roofing surfaces tested at most slopes.

A fiberglass epoxy laminated roofing surface is the most desirable surface tested for a roofing system and roll roofing is the second best. A roof slope of 1:24 is adequate for both of these surfaces. Design criteria have been established for the complete roof washdown system with the exception of the drainage gutters.

Obstructions in the path of flow of thin water films actually causes particles to move upstream and concentrate in back of the obstruction. Large particles which failed to move had the same effect on the transport of smaller particles as a fixed obstruction.

4.2 RECOMMENDATIONS

If definite needs for roof washdown systems are developed in the future, it is recommended that laboratory studies be made to supply the additional data required for the design of a complete washdown system.

These studies should be designed to determine (1) the optimum size, shape, and slope of gutters and drain pipes required to transport the mass of fallout particles and washdown water from the roof to the settling and filtration tank, and (2) the optimum configuration, size, and method of attaching common obstructions (such as skylights and vent pipes) to a roof for effective washdown removal.

REFERENCES

1. W. S. Kehrer, M. B. Hewkins. Feasibility and Applicability of Roof Washdown System. U. S. Naval Radiological Defense Laboratory Technical Report, USNRDL-TR-232, 7 May 1958.
2. R. R. Soule, R. L. Stetson, W. G. Neall. Efficacy of a Contact Water Curtain in Preventing or Minimizing Contamination. U. S. Naval Radiological Defense Laboratory Report, USNRDL-AD-187(T), 3 January 1950 (CLASSIFIED).
3. M. M. Bigger. Field Evaluation of Washdown Effectiveness. U. S. Naval Radiological Defense Laboratory Report, USNRDL-361, 1 May 1952 (CLASSIFIED).
4. M. M. Bigger, H. R. Rinnert, J. C. Sherwin, F. K. Kawahara, H. Lee. Field Effectiveness Tests of a Washdown System on an Aircraft Carrier. U. S. Naval Radiological Defense Laboratory Report, USNRDL-416, 3 June 1953.
5. G. G. Molumphy, M. M. Bigger. Proof-Testing of AW Ship Countermeasures, Operation CASTLE, Project 6.4. U. S. Naval Radiological Defense Laboratory Report, WT-927, 25 October 1957 (CLASSIFIED), published by Armed Forces Special Weapons Project.
6. R. H. Heiskell, R. J. Crew, A. J. Guay. Transport of Particulate Matter on a Near Horizontal Ideal Surface. U. S. Naval Radiological Defense Laboratory Report, USNRDL-TR-360, 21 August 1959.
7. R. H. Heiskell, R. J. Crew, R. H. Black, S. Salkin, A. J. Guay. Transport of Particulate Matter on an Ideal Surface at 0.02 Slope. U. S. Naval Radiological Defense Laboratory Report, USNRDL-TR-404, 8 March 1960.
8. R. H. Heiskell, R. J. Crew, S. Salkin, P. A. Loeb, L. Herrington, A. J. Guay. Transport of Particulate Matter on an Ideal Surface at 0.04 Slope. U. S. Naval Radiological Defense Laboratory Technical Report, USNRDL-TR-416, 29 March 1960.

9. R. H. Heiskell, R. J. Crew, P. A. Loeb. Transport of Particulate Matter on an Ideal Surface at 0.08 Slope. U. S. Naval Radiological Defense Laboratory Report, USNRDL-TR-436, 7 July 1960.
10. R. H. Heiskell, R. J. Crew, S. Salkin. Transport of Particulate Matter on an Ideal Surface at 0.165 Slope. U. S. Naval Radiological Defense Laboratory Report, USNRDL-TR-437, 7 July 1960.
11. R. H. Heiskell, R. J. Crew, N. J. Vella. Relationship of Slope to Transport of Particulate Matter by Water Films on an Ideal Surface. U. S. Naval Radiological Defense Laboratory Report, USNRDL-TR-834, 4 June 1964.
12. R. H. Heiskell, W. S. Kehrer, N. J. Vella, G. Brown, LCDR, USN (Ret). Design Criteria for Roof Washdown System. Phase I. Fallout Removal Studies on Typical Roofing Surfaces for Two Size Ranges of Particles (177-350 μ and 350-590 μ). U. S. Naval Radiological Defense Laboratory Technical Report, USNRDL-TR-672, 18 July 1963.
13. R. H. Heiskell, W. S. Kehrer, N. J. Vella. Design Criteria for Roof Washdown. Phase II Fallout Removal Studies on Typical Roofing Surfaces for Three Size Ranges of Particles (44 to 88 μ , 88 to 177 μ and 590 to 1190 μ). U. S. Naval Radiological Defense Laboratory Technical Report, USNRDL-TR-789, 11 August 1964.
14. W. S. Kehrer. A Dispenser for Depositing Simulated Dry Fallout Material on Large Roof Surfaces. U. S. Naval Radiological Defense Laboratory Technical Report, USNRDL-TR-609, 13 December 1962.
15. Fallout Shelter Surveys; Guide for Architects and Engineers, NP-10-2, National Plan Appendix Series (Appendix 2 to Annex 10 - National Shelter Plan), Office of Civil and Defense Mobilization, May 1960.
16. I. O. Huebsch. A Method of Calculating Transit and Deposit-Radiation Dose Rates and Doses for a Ship Moving in a Fallout Field. U. S. Naval Radiological Defense Laboratory Technical Report, USNRDL-TR-685, 28 October 1963.
17. District Public Works, 12th MD, Basic Units for New Construction and Building Cost Indexes. 19 January 1964.
18. Robert Snow Means Co., Engineers and Estimators, P. O. Box 36, Duxbury, Mass. 02332. "Building Construction Cost Data.", 22nd Annual Edition, 1964.

APPENDIX A

CALCULATION OF DOSAGE REDUCTION FACTORS IN SIMPLE WINDOWLESS ABOVE-GROUND BUILDINGS

Method of calculation is given in Supplement A (Part 2 and 3) and Supplement B (Part 2,3 and 7) of Ref. 15. Charts and tables cited in this appendix are from Ref. 15.

The following specifications and assumptions are used:

1. Roofs are 30 ft above ground floor.
2. Walls are 18-inch concrete up to roof and have a mass thickness of 225 lb/ft².
3. Detectors are located 3 ft above the center of the ground floor.
4. Roofs are assumed to have zero mass thickness.

TABLE A.1

Calculation of Exposure Reduction Factors in Simple, Windowless,
Above-Ground Buildings*

	Floor Area		
	1,000 ft ² 25 x 40 ft	4,000 ft ² 30 x 80 ft	10,000 ft ² 60 x 170 ft
<u>Roof Contribution</u>			
Total Area (ft ²)	1,000	4,000	10,000
Distance - roof to detector (ft)	27	27	27
Distance correction factor	0.14	0.14	0.14
Adjusted total area (ft ²)	140	560	1,400
Overhead mass thickness	0	0	0
Roof contribution (from Chart 2)	0.033	0.096	0.15
<u>Skyshine</u> (from Table CF-2)	0.0050	0.0144	0.0225
<u>Ground Contribution</u>			
Ground floor area (ft ²)	1,000	4,000	10,000
Exterior wall mass thickness (lb/ft ²)	225	225	225
Percent of wall which is solid	100 %	100 %	100 %
Height of detector (ft)	3	3	3
Ground contribution (from Chart 3)	0.0045	0.0028	0.0019
Total contribution of roof, ground, and skyshine	0.0425	0.1132	0.1744
<u>Transit Dose</u>			
Building shielding factor**			
through roof	0.1380	0.3360	0.5230
through walls	0.0037	0.0036	0.0028
Total Shielding Factor	0.1417	0.3396	0.5258
Fraction of total free-field accumulated dose***	0.03	0.03	0.03
Transit dose fraction	0.0043	0.0102	0.0158

* Calculation for Roof Contribution, Skyshine, and Ground Contribution made in accordance with the method described in Ref. 15.

** Determined by Endel Laumets. Graphic Method for Computing Steel-Slab Attenuation of Gamma Radiation From Air Volume-Source Configuration. U.S. Naval Radiological Defense Laboratory Technical Report in preparation.

*** Transit and Deposition dose was calculated using the method presented in** for a 5-Megaton surface burst in a 15-knot wind using Nevada particle-size-activity distribution. The rate of cloud rise and expansion used in the computer program was in accordance with Ref. 16. The calculations showed the transit dose to be 2.5 to 3 % of the total infinite dose.

APPENDIX B

CONSTRUCTION COST ESTIMATES

(References 17 and 18 used as a guide in making these cost calculations)

	Building Size (ft ²)		
	1,000 (25 x 40 ft)	4,000 (50 x 80 ft)	10,200 (60 x 170 ft)
<u>Washdown System Only</u>			
Piping, Nozzles & Fittings Installed	\$ 660	\$2,176	\$4,920
Drainage System	230	464	870
Water Supply Tank Including Filters*	750	1,200	2,210
Concrete Pit for Tank	560	1,393	3,577
Pump Installed	350	860	1,800
	<u>\$2,550</u>	<u>\$6,093</u>	<u>\$13,377</u>
10% Contingency	255	609	1,338
Total	<u>\$2,805</u>	<u>\$6,702</u>	<u>\$14,715</u>
<u>Roof on New Structure</u>			
<u>Structural Steel Trusses and Wood Roof</u>			
Steel Trusses**	\$1,100	\$2,890	\$7,600
Purlins (2 in. x 3/4 in. Plywood Material and Labor	645	2,670	5,636
10% Contingency	175	556	1,324
Total	<u>\$1,920</u>	<u>\$6,116</u>	<u>\$14,560</u>
<u>Roofing Surface</u>			
Roll Roofing	\$ 140	\$ 880	\$4,796
Fiberglass Epoxy Laminate	1,250	4,400	11,000
<u>Total Washdown System and Roof Cost</u>			
Roll Roofing	\$4,865	\$13,698	\$34,071
Fiberglass Epoxy Laminate	5,975	17,218	40,275

* Supply Tank Sizes, respectively: 170, 460 and two at 550 ft³.

**Longspan nailable joists with a Warren-type web system similar, or equal to Sheffield Division, Armco Steel Corporation, Kansas City, Mo. Model No. 16H5, 20H5, and 26H9 for 1,000, 4,000, and 10,000 ft² buildings.

SUMMARY OF RESEARCH REPORT

DESIGN OF ROOF WASHDOWN SYSTEMS

USNRDL-TR-1064, dated 27 January 1965 by R. H. Heiskell.

PURPOSE

The purpose of this report is to describe an operational roof wash-down system for the removal of radioactive fallout particles. A roof washdown system can be used instead of costly roof shielding to reduce radiation exposure to personnel inside the building.

OBJECTIVE

To develop design specifications for a roof washdown system from experimental data.

SCOPE

This report covers:

- a. A summary of all previous work on the study of basic design requirements for roof washdown systems and gives a comparison of effectiveness on five typical roofing surfaces.
- b. Evaluation results on a superior method of applying the wash-down water to a building roof.
- c. An analysis of roof washdown limitations.
- d. A complete basic roof washdown system for a properly shielded building which could be occupied during a heavy radioactive fallout and continuously, around the clock, after the nuclear detonation.
- e. An analysis of reduction in interior dosage by roof washdown on a variety of building sizes.
- f. Estimated comparative construction cost of a roof washdown system on a light roof of zero shielding mass to a high mass roof which would give an equivalent interior dosage reduction.

SIGNIFICANT FINDINGS AND CONCLUSIONS

Roof washdown is of value as a radiological countermeasure only on buildings with heavily shielded walls or where the occupants are confined to the center of a building with a very large floor area.

The rotary lawn type sprinklers when installed in sufficient number with proper spacing will remove 95 to 98 % of fallout particles from all five of the standard roofing surfaces tested at most slopes.

A fiberglass epoxy laminated roofing surface is the most desirable surface tested for a roofing system and roll roofing is the second best.

The effect of particle size on washdown efficiency was practically eliminated by the rotary nozzles on most of the standard roofing surfaces. Slope was also found to be of much less importance with the rotary nozzles.

A complete recirculating roof washdown system on a fiberglass epoxy laminated roof will cost only 45 % of the cost of a 12 inch. concrete roof that would give a similar reduction of 98 % in the roof contribution to gamma reduction exposure inside the structure.

RECOMMENDATIONS

If definite needs for roof washdown systems are developed in the future, it is recommended that studies be made to develop (1) the optimum design specifications for gutters and drain pipes to handle the mass of fallout particles and washdown water and (2) the optimum specifications for protrusions and obstructions on the roof which will permit effective washdown removal.

UNCLASSIFIED
Security Classification

DOCUMENT CONTROL DATA - R&D

(Security classification of title, body of abstract and indexing annotation must be entered when the overall report is classified)

1. ORIGINATING ACTIVITY (Corporate author) U.S. Naval Radiological Defense Laboratory San Francisco, California 94135		2a. REPORT SECURITY CLASSIFICATION UNCLASSIFIED	
		2b. GROUP	
3. REPORT TITLE DESIGN OF ROOF WASHDOWN SYSTEMS (Final Report)			
4. DESCRIPTIVE NOTES (Type of report and inclusive dates)			
5. AUTHOR(S) (Last name, first name, initial) Heiskell, Raymond H.			
6. REPORT DATE 20 December 1966		7a. TOTAL NO. OF PAGES 58	7b. NO. OF REFS 18
8a. CONTRACT OR GRANT NO. OCD Contract No. CDM-SR-59-54, Work Unit 1113A b. PROJECT NO.		8a. ORIGINATOR'S REPORT NUMBER(S) USNRDL-TR-1064	
c. d.		9b. OTHER REPORT NO(S) (Any other numbers that may be assigned this report)	
10. AVAILABILITY/LIMITATION NOTICES Distribution of this document is unlimited.			
11. SUPPLEMENTARY NOTES		12. SPONSORING MILITARY ACTIVITY Office of Civil Defense Washington, D.C. 20310	
13. ABSTRACT Roof washdown studies were conducted on typical roofing surfaces and a basic washdown system was developed. An analysis of the roof washdown counter-measure showed it to be valuable only on buildings with heavily shielded walls or where the occupants are confined to the center of a building with a very large floor area. A complete recirculating roof washdown system will cost only 45 % of the cost of a concrete roof that would give a similar reduction of 98 % in the roof contribution to gamma radiation exposure inside the structure.			

DD FORM 1473
1 JAN 64

UNCLASSIFIED
Security Classification

14. KEY WORDS	LINK A		LINK B		LINK C	
	ROLE	WT	ROLE	WT	ROLE	WT
Roofs Washdown Surface properties Particles Radioactive fallout Decontamination						

INSTRUCTIONS

1. ORIGINATING ACTIVITY: Enter the name and address of the contractor, subcontractor, grantee, Department of Defense activity or other organization (*corporate author*) issuing the report.

2a. REPORT SECURITY CLASSIFICATION: Enter the overall security classification of the report. Indicate whether "Restricted Data" is included. Marking is to be in accordance with appropriate security regulations.

2b. GROUP: Automatic downgrading is specified in DoD Directive S200.10 and Armed Forces Industrial Manual. Enter the group number. Also, when applicable, show that optional markings have been used for Group 3 and Group 4 as authorized.

3. REPORT TITLE: Enter the complete report title in all capital letters. Titles in all cases should be unclassified. If a meaningful title cannot be selected without classification, show title classification in all capitals in parenthesis immediately following the title.

4. DESCRIPTIVE NOTES: If appropriate, enter the type of report, e.g., interim, progress, summary, annual, or final. Give the inclusive dates when a specific reporting period is covered.

5. AUTHOR(S): Enter the name(s) of author(s) as shown on or in the report. Enter last name, first name, middle initial. If military, show rank and branch of service. The name of the principal author is an absolute minimum requirement.

6. REPORT DATE: Enter the date of the report as day, month, year; or month, year. If more than one date appears on the report, use date of publication.

7a. TOTAL NUMBER OF PAGES: The total page count should follow normal pagination procedures, i.e., enter the number of pages containing information.

7b. NUMBER OF REFERENCES: Enter the total number of references cited in the report.

8a. CONTRACT OR GRANT NUMBER: If appropriate, enter the applicable number of the contract or grant under which the report was written.

8b, 8c, & 8d. PROJECT NUMBER: Enter the appropriate military department identification, such as project number, subproject number, system numbers, task number, etc.

9a. ORIGINATOR'S REPORT NUMBER(S): Enter the official report number by which the document will be identified and controlled by the originating activity. This number must be unique to this report.

9b. OTHER REPORT NUMBER(S): If the report has been assigned any other report numbers (*either by the originator or by the sponsor*), also enter this number(s).

10. AVAILABILITY/LIMITATION NOTICES: Enter any limitations on further dissemination of the report, other than those

imposed by security classification, using standard statements such as:

- (1) "Qualified requesters may obtain copies of this report from DDC."
- (2) "Foreign announcement and dissemination of this report by DDC is not authorized."
- (3) "U. S. Government agencies may obtain copies of this report directly from DDC. Other qualified DDC users shall request through _____."
- (4) "U. S. military agencies may obtain copies of this report directly from DDC. Other qualified users shall request through _____."
- (5) "All distribution of this report is controlled. Qualified DDC users shall request through _____."

If the report has been furnished to the Office of Technical Services, Department of Commerce, for sale to the public, indicate this fact and enter the price, if known.

11. SUPPLEMENTARY NOTES: Use for additional explanatory notes.

12. SPONSORING MILITARY ACTIVITY: Enter the name of the departmental project office or laboratory sponsoring (*paying for*) the research and development. Include address.

13. ABSTRACT: Enter an abstract giving a brief and factual summary of the document indicative of the report, even though it may also appear elsewhere in the body of the technical report. If additional space is required, a continuation sheet shall be attached.

It is highly desirable that the abstract of classified reports be unclassified. Each paragraph of the abstract shall end with an indication of the military security classification of the information in the paragraph, represented as (TS), (S), (C), or (U).

There is no limitation on the length of the abstract. However, the suggested length is from 150 to 225 words.

14. KEY WORDS: Key words are technically meaningful terms or short phrases that characterize a report and may be used as index entries for cataloging the report. Key words must be selected so that no security classification is required. Identifiers, such as equipment model designation, trade name, military project code name, geographic location, may be used as key words but will be followed by an indication of technical context. The assignment of links, rules, and weights is optional.

CONT.

U.S. NAVAL RADIOLOGICAL DEFENSE LABORATORY
San Francisco, California 94135

224
EB:cls
24 January 1967

From: Commanding Officer and Director
To: Distribution for Report USNRDL-TR-1064

Subj: U.S. Naval Radiological Defense Laboratory Report USNRDL-TR-1064
entitled "Design of Roof Washdown Systems (Final Report)" (UN-
CLASSIFIED) by R. H. Heiskell; errata for

Encl: (1) Corrected page 11/12 of TR-1064

1. Recipients of subject report are requested to remove page 11/12 from
the report and replace it with the corrected page 11/12 forwarded here-
with as enclosure (1).

T. J. Mathews
T. J. MATHEWS
By direction

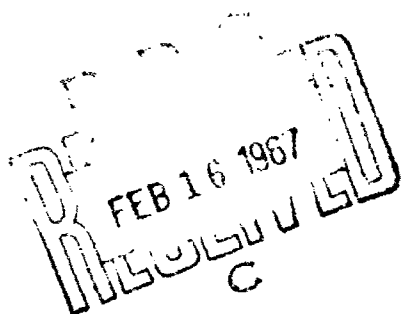

ARCHIVE COPY

from a water supply line running lengthwise down the center of each test surface. (Fig. 5) The lowest portion of the nozzles was about 8" above the test surface and were set to oscillate only 90° to each side of the lengthwise centerline.

2.1.3 Fallout Disperser

The fallout disperser system consisted of 18 individual dispersers mounted over each of the two tilt planes, approximately 24 ft above the planes when the planes were in a horizontal position. During operation, continuously metered amounts of the simulant particles were fed to the sand blast nozzles in the individual dispersers, where an air stream picked them up and blasted them against a deflector plate (Fig. 6). The particles then scattered and fell over the 8 by 8-ft area covered by each disperser.

Regulation of the working air pressure and the addition of deflector panels and curtains to the individual dispersers were required to obtain uniform distribution of the particles on the test surfaces.

Further details of the fallout dispersers are given in References 12, 13, and 14.

2.2 EXPERIMENTAL PROCEDURES

In all the washdown-effectiveness studies, a fallout dispersal period of 30 min at a fallout rate of approximately 2 g/min/ft² was used. This rate and the total amount deposited were used because they represent an extreme case which greatly exceeds the maximum that would be expected from a land surface nuclear detonation.

The fallout simulant dispersal was started after the washdown water was turned on, and the test surfaces had been completely wetted. The washdown water flowed during the 30-min dispersal period and for 30 min after the cessation of deposition.

The particles removed from each test surface during this 1-hour period were collected in sieves (Fig. 7). After the washdown period, the sieves were replaced with clean ones, and the residual fallout simulant on the surfaces was removed by manual flushing with a garden hose for 30 min. Longer and repeated flushing removed more material, but the additional percentage removed was only a fraction of a percent after the first 15 min of flushing with the garden hose.

CFSTI
MAR 20 1967
RECEIVED

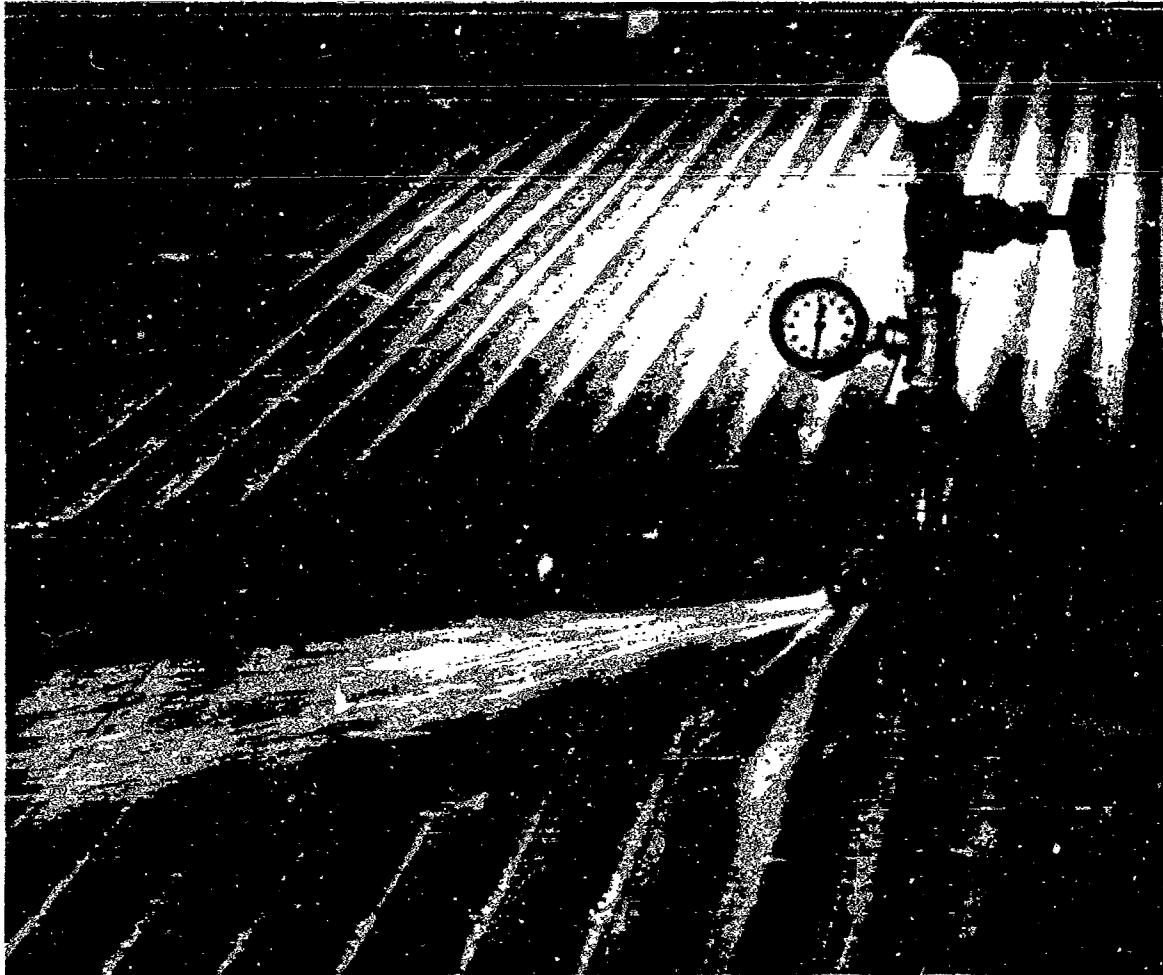

Fig. 5 Rotary Nozzle. Mounted over corrugated roofing surface.