

República Argentina  
Comisión Nacional de Energía Atómica  
Departamento de Metalurgia

AD640971

PRIMERA CONFERENCIA DE EXPERTOS LATINOAMERICANOS  
EN METALURGIA DE TRANSFORMACION

DISC-12007 DE NS 5215  
COMPTON 13 10/19/66

FIRST LATIN AMERICAN CONFERENCE ON PROCESS  
METALLURGY AND METAL WORKING

Buenos Aires, 18 - 23 Agosto, 1964

CLEARINGHOUSE FOR FEDERAL SCIENTIFIC AND TECHNICAL INFORMATION		
Hardcopy	Microfiche	
\$7.10	\$1.75	406 pp/BL
ARCHIVE COPY		

code 1

VOLUMEN II

DDC  
RECORDED  
OCT 19 1966  
RUBEN L  
C

**Best  
Available  
Copy**

**PRIMERA CONFERENCIA DE EXPERTOS LATINGAMERICANOS**

**EN METALURGIA DE TRANSFORMACION**

**Esta Conferencia fué patrocinada por la Air Force Office  
of Scientific Research - Grant AF-AFOSR-717-65.**

\*

**FIRST LATIN AMERICAN CONFERENCE ON PROCESS**

**METALLURGY AND METAL WORKING**

**This Conference was sponsored by the Air Force Office  
of Scientific Research - Grant AF-AFOSR-717-65.**

\*

**Buenos Aires, 18-23 Agosto, 1964**

**Volumen II**

**Comisión Nacional de Energía Atómica  
Departamento de Metalurgia  
República Argentina  
1966**

**Nota:** La Comisión Nacional de Energía Atómica no se hace responsable, como Institución, por la información y opiniones vertidas en esta publicación.

**Note:** The Argentine Atomic Energy Commission is not responsible, as a body, for the statements and opinions advanced in this publication.

Impreso en Buenos Aires - Argentina  
Agosto 1966

I N D I C E - I N D E X

VOLUMEN I

- A. PROLOGO - FOREWORD
- B. INDICE - INDEX
- C. INTRODUCCION - INTRODUCTION
- D. PROGRAMA TECNICO - TECHNICAL PAPERS
- E. TRABAJOS PRESENTADOS - PAPERS PRESENTED
- I. -"Desarrollos Recientes en Materiales y Procesos"  
-"Some Recent Developments in Engineering Materials and Processes"  
E. R. PARKER  
- (University of California,  
USA)
- II. -"Desarrollo y Plan de Actividades del Laboratorio de Fundición del  
Instituto de Tecnología y Química de la Facultad de Ingeniería y  
Agrimensura de la Universidad de la República Oriental del Uruguay"  
-"Development and Plan of Activities of the Casting Laboratory at the  
Metals Department of the Chemistry and Technology Institute of the  
School of Engineering of the University of Uruguay"  
ALFONSO GAGGERO and BLAS MELISSARI  
(Facultad de Ingeniería, Universidad del Uruguay) -
- III. -"El Instituto de Investigaciones Tecnológicas de San Pablo y sus  
Contribuciones al Desarrollo de la Metalurgia en el Brasil".  
-"The Technological Research Institute of Sao Paulo and its Con-  
tributions to the Development of Metallurgy in Brazil"  
LUIZ CORREA DA SILVA  
(Instituto de Pesquisas Tecnológicas, Sao Paulo, Brasil) -

- IV.            -"Plan de Actividades del Departamento de Metalurgia de la Comisión Nacional de Energía Atómica, Argentina"  
              -"Plan of Activities of the Department of Metallurgy of the CNEA"  
                  JORGE A. SABATO  
                  (Departamento de Metalurgia, CNEA, Argentina)
- V.             -"Plan de Actividades del Servicio de Asistencia Técnica a la Industria Metalúrgica"  
              -"Plan of Activities of the Service of Technical Assistance to Industry (SATI)"  
                  OSCAR WORTMAN  
                  (Departamento de Metalurgia, CNEA, Argentina)
- VI.            -"Breve Reseña de la Investigación Metalúrgica en Chile"  
              -"A Review of the Metallurgical Research Activities in Chile"  
                  DAVID FULLER  
                  (Universidad Católica de Chile)
- VII.           -"Algunos Comentarios sobre la Metalurgia Física del Hierro y del Acero"  
              -"Some Remarks on the Physical Metallurgy of Iron and Steel"  
                  H. PAXTON  
                  (Carnegie Institute of Technology, USA)
- VIII.          -"Nuevos Aceros Americanos Ultra Resistentes"  
              -"New American Ultrahigh-strength Steels"  
                  F. MORRAL  
                  (Batelle Memorial Institute, USA)
- IX.            -"Racionalización en el empleo de aceros de construcción"  
              -"Rationalized Use of Constructional Steels"  
                  DIONISIO FARIAS  
                  (Universidad Católica de Córdoba, Argentina) -
- X.             -"Materiales Metálicos Celulares"  
              -"Cellular Metallic Materials"  
                  S. LIPSON  
                  (Frankford Arsenal, USA)



- XIX.        -"Refinación a Fuego y otras Soluciones para los Problemas Presentados por la Presencia de Impurezas en Cobre Latones Alfa"  
              -"Fire-Refining Process and other Solutions to Problems Arisen from Impurities in Cu and Brass"  
                  H. J. DESTAILLATS, E. GERARDUZZI R. A. MORANDO  
                  (Departamento de Metalurgia, CNEA, Argentina)
- XX.         -"Determinación de las Propiedades Residuales de Arenas de Moldeo"  
              -"Determination of Residual Properties of Foundry Sands"  
                  V. LO RE  
                  (I. P. T., Sao Paulo, Brasil)
- XXI.        -"Algunos Aspectos del Trabajado de Metales"  
              -"Some Aspects of Metal Forming"  
                  E. THOMSEN  
                  (University of California, USA)
- XXII.       -"El Programa Coordinado de Trabajado y Procesado de Metales de las tres Fuerzas Armadas"  
              -"Tri-Service Coordinated Metal Working and Processing Program"  
                  N. L. REED  
                  (U. S. Army Materials Research Agency, USA)
- XXIII.      -"Algunos Aspectos Técnicos del Programa de Trabajado de Metales, Procesos y Equipos (M. P. E. P.) de los Estados Unidos de Norte América"  
              -"Some Technical Aspects of the United States Metalworking, Processes and Equipment Program (M. P. E. P.)"  
                  N. PROMISEL  
                  (U. S. Navy Bureau of Naval Weapons, USA)
- XXIV.       -"Investigación de Materiales en Apoyo de una Tecnología Avanzada"  
              -"Materials Research in Support of Advanced Technology"  
                  S. VALENCIA . P. A. G. CARBONARO  
                  (U. S. Army Materials Research Agency, USA)
- XXV.        -"Producción de Electrodo Rotativos de Cobre-Cobalto-Silicio"  
              -"Production of Copper-Cobalt-Silicon Rotating Seam-Welding Electrodes"  
                  S. DE SOUZA . L. CORREA DA SILVA  
                  (I. P. T., Sao Paulo, Brasil)



- XXVI. -"Propiedades de una Aleación de Cobre de Alta Resistencia al Ablandamiento y Alta Conductividad"  
-"Fabrication and Properties of a High Resistance to Softening and High Conductivity Copper Alloy"  
D. OBRUTSKY, M. SARRATE, O. WORTMAN  
(Departamento de Metalurgia, CNEA, Argentina)
- XXVII. -"Manufactura de Chapas No-Ferrosas"  
-"Non Ferrous Metal Sheet Manufacturing"  
F. MORRAL  
(Battelle Memorial Institute, USA)
- XXVIII. -"Influencias de las Investigaciones sobre Materiales en la Optimización de Diseño"  
-"Design Optimization Through Materials Research"  
M. STEINBERG  
(Lockheed Missiles and Space Co., USA)
- XXIX. -"Trabajado de Metales con Explosivos"  
-"Explosive Working of Metals"  
J. RINEHART  
(Colorado School of Mines, USA)
- XXX. -"Nuevos Procesos de Manufactura de Metales en los EE. UU. - Posible Aplicación en Países Latinoamericanos"  
-"New Metal Manufacturing Processes in the USA of Possible Application in Latin American Countries"  
F. MORRAL  
(Battelle Memorial Institute, USA)
- XXXI. -"Colada Contínua de Aluminio"  
-"Continuous Casting of Aluminum"  
J. CIARLO, R. MEILLAT  
(C. A. M. E. A. . Argentina)
- XXXII. -"Estudio de la Colaminación de metales"  
-"Roll-bonding of Metals"  
J. ALMAGRO, G. CUSMINSKY, C. A. MARTINEZ VIDAL  
(Departamento de Metalurgia, CNEA, Argentina)
- XXXIII. -"Influencia del Efecto de Tamaño y Entalladura en la Resistencia a la Fatiga de Elementos Estructurales y de Máquinas"  
-"The Effect of Size and Shape on the Fatigue Strength of Structural and Machine Members"  
R. KUGUEL  
(Ins. Nacional de Tecnología Industrial, INTI, Argentina)

- XXXV. -"Estrategia de la investigación metalúrgica en Latino-América"  
- "Strategy of Metallurgical Research on Latin America"  
J. SABATO  
(Departamento de Metalúrgia, CNEA, Argentina) -
- XXXVI. -"Objetivos de una colaboración regional en materia de investigación  
tecnológica"  
- "Objectives of Regional Collaboration on Technological Searching"  
J. A. SABATO  
(Departamento de Metalúrgia, CNEA, Argentina) -

ALGUNS PROBLEMAS DE CORROSAO DE METAIS (\*)

Stephan Wolynec (\*\*)

Idel Metzger (\*\*\*)

RESUMO - No presente trabalho os autores fazem um apanhado sobre alguns problemas de corrosao de metais que devido ao seu alto grau de destrutividade tem sido trazidos para estudo no Instituto de Pesquisas Tecnológicas. A descrição de cada caso é precedida de um resumo teórico sobre o mecanismo particular da corrosao que nele atua. São descritos os seguintes casos: corrosao por correntes dispersas ("stray currents") de tubos de aço enterrados de uma adutora de água; corrosao sob tensão ("stress corrosion") de arames de aço empregados na protensão de concreto; corrosao de contato ("crevice corrosion") de chapas de aço inoxidável; corrosao intergranular devida a sensitização (precipitação de carbonetos intergranulares) de tubos de aço inoxidável.

- 
- (\*) Contribuição Técnica N<sup>o</sup> , apresentada ao XIX Congresso Anual da Associação Brasileira de Metais; São Paulo, S. P. julho de 1964.
- (\*\*) Membro da ABM; Engenheiro Responsável da Seção de Físico-Química Metalúrgica do Instituto de Pesquisas Tecnológicas; São Paulo, S. P.
- (\*\*\*) Membro da ABM; Engenheiro Assistente da Seção de Físico-Química Metalúrgica do Instituto de Pesquisas Tecnológicas; São Paulo, S. P.

## I INTRODUÇÃO

Os prejuizos que a corrosao dos metais causa a indústria e a comunidade constituem uma parcela apreciável da sua receita. Ela diminui a eficiencia dos equipamentos, contamina produtos, destrói estruturas e causa acidentes.

A applicao de processos científicos e tecnológicos pode reduzir de maneira efetiva os efeitos da corrosao. Em várias partes do mundo estuda-se, exaustivamente, o fenomeno e desenvolvem-se técnicas e produtos, sempre mais efficientes no sentido de minorar a sua ação.

No Brasil pouca atencao tem sido dispensada aos problemas de corrosao. O nosso "know how" sobre o assunto é ainda incipiente. O recente desenvolvimento tecnológico do país exige, no entanto, que se lhe de a devida importancia.

No decorrer dos últimos 20 anos, o Instituto de Pesquisas Tecnológicas de Sao Paulo teve oportunidade de, através da sua Secção de Metalografia e, no último ano, através da Secção de Físico-Química Metalúrgica, lidar com uma variedade apreciável de problemas de corrosao, o que lhe permitiu acumular certa experiencia no assunto. O presente trabalho visa difundir alguns dos problemas apresentados nesse tempo e que apresentam interesse geral.

Dentre os problemas de corrosao, devemos distinguir os fenomenos, que sao corriqueiros, daqueles cujas consequencias inesperadas os fazem assumir importancia excepcional. Referimo-nos, no primeiro caso, aos problemas de corrosao de estruturas metálicas em meios perfeitamente conhecidos e cuja agressividade é também perfeitamente previsível. Neste caso, uma vez considerados os fatores economicos, procura-se utilizar os metais ou métodos mais apropriados para resistir a agressividade do meio. Desse modo, a corrosao fica sob controle, isto é, a ação destrutiva da corrosao é diminuida ao máximo, dentro dos limites viáveis e é computada no custo de utilizacao, quando necessário.

No segundo caso, os problemas que surgem nao sao previstos e resultam de condições que nao foram levadas em consideracao quando do projeto da estrutura. Em virtude disso, nem sempre se faz a escolha apropriada dos metais ou métodos de protecao contra a agressao do meio, resultando, em geral, um colapso desastroso. O desconhecimento de certas características físico-químicas do meio e a nao consideracao de certos fatores mecanicos e de construçao como possíveis promotores da corrosao, levam a adocao de projetos impróprios, com as consequencias posteriores.

De um modo geral, os problemas trazidos a apreciacao do Instituto de Pesquisas Tecnológicas enquadram-se nesse segundo caso. Trata-se, quase sempre

pre, de corrosões que, em face de seu desenvolvimento altamente danoso, causam graves transtornos aos interessados.

Os problemas que passamos a descrever referem-se a corrosão por correntes dispersas, corrosão em frestas, corrosão intergranular de aços inoxidáveis e corrosão sob tensão. A descrição de cada problema é precedida de um resumo teórico sobre o mecanismo particular de corrosão que nele atua.

## II CORROSAO DE METAIS POR CORRENTES DISPERSAS

### II.1 Mecanismo da corrosao

A corrosão por correntes dispersas ("stray-currents corrosion" ou "electrolysis") ocorre em estruturas metálicas enterradas ou submersas. Ela é devida a correntes causadas por uma diferença de potencial entre a estrutura em questão e partes de outras instalações ou equipamentos próximos. Essa diferença de potencial é geralmente causada por um gerador, de corrente contínua ou, então, uma outra estrutura que se encontra num potencial diferente.

Os danos que esse tipo de corrosão pode causar são de apreciável monta, uma vez que há uma aceleração e uma localização preferencial do ataque. A seguir, damos alguns exemplos de casos em que a corrosão por correntes dispersas pode ocorrer:

- corrosão de oleodutos ou aquedutos, enterrados próximos de estradas de ferro eletrificadas ou linhas de bondes;
- corrosão de cascos de navios em virtude das operações de solda elétrica, quando acostados em estaleiros para construção ou reparos;
- corrosão de estruturas enterradas, quando próximas de outras protegidas catódicamente;
- etc.

O aparecimento de correntes dispersas num determinado meio eletrolítico é devido a uma deficiência, ou eventualmente ausência, de isolamento de alguma porção de um circuito que passa por esse meio e que encontra-se num potencial diferente do potencial do meio. Como a condutividade média da maioria dos me-

tais é muito maior do que condutividade média dos diferentes eletrólitos, principalmente se considerarmos como tais o solo ou a água do mar, as estruturas enterradas ou submersas atuam como condutores de baixa resistência e, em consequência, passam a conduzir a maior parte da corrente causada pela diferença de potencial mencionada.

Existem dois mecanismos pelos quais as correntes dispersas podem promover corrosão numa estrutura metálica (1). No primeiro mecanismo, esquematizado na Fig. 1, uma parte da corrente dispersa que passa pela estrutura é, em virtude do gradiente de potencial existente, desviada pelo eletrólito. No segundo mecanismo, esquematizado na Fig. 2, há uma inversão de papéis, cabendo a estrutura metálica desviar parte da corrente dispersa que circula pelo eletrólito. Tanto o primeiro como o segundo mecanismos dão origem as células de corrosão, responsáveis pela entrada, na região anódica, de cátions metálicos em solução no eletrólito. Essas células de corrosão dão origem as chamadas "correntes de corrosão" que podem ser encaradas como fluxos de cargas positivas. Esses fluxos não são necessariamente acompanhados de movimento de cátions, mas antes pela transferência de carga de um ponto a outro. O sentido de uma corrente de corrosão coincide com o sentido convencional de uma corrente elétrica, ou seja, é contrário ao sentido do fluxo das cargas negativas.

Em cada um dos mecanismos, tanto a região anódica como região catódica, são sujeitas a polarização devido a corrente que flui pelo circuito de corrosão. Esta polarização é uma função da corrente do circuito. Assim, sendo  $V_c^0$  e  $V_a^0$  os potenciais do catodo e do anodo, respectivamente, em circuito aberto; os correspondentes potenciais  $V_c$  e  $V_a$  em circuito fechado serão (2):

$$V_c = V_c^0 - f_c(i) \quad (1)$$

$$V_a = V_a^0 + f_a(i) \quad (2)$$

onde

$f_c(i)$  = função de polarização do catodo,  
 $f_a(i)$  = função de polarização do anodo e  
 $i$  = corrente de corrosão

Tendo em vista a segunda lei de Kirchhoff, pode-se escrever:

$$V_c - V_a = Ri \quad (3)$$

onde

$R$  = resistência total do circuito de corrosão.

Substituindo (1) e (2) em (3), resulta:

$$(V_c^0 - V_a^0) - f_c(i) + f_a(i) = Ri$$

Como  $V_c^0 - V_a^0 = V_d =$  diferença de potencial induzida por correntes dispersas e fazendo-se  $f_c(i) + f_a(i) = f(i)$ , resulta:

$$i = \frac{V_d - f(i)}{R} \quad (4)$$

## II.2 Meios de prevenção

Tendo em vista que a intensidade da corrosão é uma função direta da corrente  $i$ , todo processo que vise diminuí-la deve reduzir o valor de  $i$  sem aumentar a densidade da corrente anódica. Deste modo, considerando-se a relação (4), a corrosão por correntes dispersas pode ser debelada por (1):

- a - diminuição ou eliminação de  $V_d$ ;
- b - aumento de  $f(i)$ ;
- c - aumento de  $R$ .

### a Diminuição ou eliminação de $V_d$ :

Esta diminuição ou eliminação pode ser conseguida de dois modos:

- 1º por eliminação das correntes dispersas, isolando-se convenientemente todo o circuito responsável pelo seu aparecimento no eletrólito;
- 2º Levando a estrutura a um potencial mais negativo, ou seja, tornando-a catódica com relação ao eletrólito. Conseguise isto por vários processos, entre os quais, a proteção catódica e a ligação da estrutura ao pólo negativo da fonte geradora das correntes dispersas constituindo os meios mais práticos.

Aumento de  $f(i)$ :

O aumento da polarização  $f(i)$  se consegue revestindo as regiões catódicas da estrutura com camadas protetoras apropriadas (em geral, asfalto betuminoso). Com isto promove-se, em virtude dos furos no revestimento, um aumento na densidade de corrente catódica e, em consequência, da polarização. Este processo, em geral, é de difícil aplicação pois a localização das áreas catódicas não é simples.

c Aumento de  $R_i$ :

O aumento da resistência do circuito pode ser conseguido aumentando-se a resistência do eletrólito que circunda a estrutura. No caso de estruturas enterradas no solo consegue-se isto substituindo o solo, que circunda a estrutura, por um material de elevada resistividade elétrica como, por exemplo, areia limpa. Um outro processo de aumentar  $R$  consistiria em se aumentar a resistência da estrutura, inserindo juntas isolantes entre várias porções da mesma. No entanto, este processo pode, as vezes, criar problemas de corrosão por correntes dispersas nas partes internas de estruturas que contem eletrólitos.

A adoção, de um ou outro processo de eliminação ou diminuição de corrosão por correntes dispersas é determinada por fatores econômicos peculiares a cada caso.

II.3 Corrosão de tubos de uma linha adutora de águaa) Generalidades

O caso que passamos a descrever constitui um exemplo típico da corrosão de metais por correntes dispersas. Trata-se da corrosão ocorrida com os tubos de aço da linha adutora de água de um município do Estado de São Paulo (3).

A linha adutora estende-se por cerca de 14 km, entre o reservatório e a caixa d'água da cidade. Ela é constituída por tubos de aço de 500 mm de diâmetro, ligados por solda, e apresenta dois trechos distintos.



O primeiro trecho, que se estende desde o reservatório até, aproximadamente, metade do percurso da adutora, é o mais antigo e é constituído por tubos soldados lateralmente. O segundo trecho, que corresponde ao restante da adutora, é o mais recente e é constituído por tubos soldados em hélice.

Toda a linha adutora é subterrânea, com excepção das regiões em que ela atravessa lagoas ou riachos e de em que ela passa sobre uma estrada de ferro. Nessas regiões ela é aérea.

Os tubos da adutora são todos revestidos externamente por uma camada de "primer" e uma outra de asfalto, sendo que, nos tubos do trecho mais novo, esse asfalto apresenta-se misturado com la de vidro. A espessura do revestimento, no trecho mais velho, varia entre 2,5 e 3,0 mm e no mais novo entre 3,5 e 4,0 mm.

Em dois pontos de seu percurso a linha adutora cruza com a estrada de ferro. Um desses pontos já foi mencionado anteriormente e o outro situa-se numa região na qual a adutora passa por baixo dos trilhos.

A disposição da estrada de ferro, com relação a linha adutora, é mostrada na Fig. 3. Observa-se que ela se mantém razoavelmente paralela a linha adutora num percurso de, aproximadamente, 2 km, variando a distância entre ambos de 125 a 325 m.

A estrada de ferro é de uma única via e emprega sistema de tração elétrica por corrente contínua. A tensão na linha é de 600 volts e os trilhos estão ligados ao terminal negativo dos geradores. No trecho indicado na Fig. 3, a estrada de ferro é alimentada por dois geradores. Um desses geradores (Gerador 1) está instalado perto da cidade e a sua ação estende-se para além do cruzamento com a linha adutora.

O trecho restante da linha é alimentado por um outro gerador (Gerador 2) instalado no outro extremo da estrada de ferro.

b) Observação da corrosão

A corrosão dos tubos da adutora foi notada ao longo de todo o seu percurso. No entanto, manifestou-se de modo mais grave em duas regiões, cada uma próxima de uma lagoa e não muito afastada da estrada de ferro. A primeira dessas regiões localiza-se no trecho mais antigo da adutora, próximo ao seu cruzamento com a estrada de ferro na qual a adutora passa

sob os trilhos. Um esquema do perfil dessa região está indicado na Fig. 4. A segunda região, consideravelmente atacada, encontra-se no trecho novo da adutora e corresponde a porção que mais se aproxima da estrada de ferro, antes do ponto em que as duas se separam (ver região assinalada na Fig. 3).

Em ambas as regiões a corrosão promoveu nos tubos mais de 100 furos, resultando, em consequência, fortes vazamentos. Este fato provocou uma forte erosão no terreno, expondo uma boa parte da tubulação e chegando, em certos lugares, a criar problemas de estabilidade mecânica. A Fig. 5 mostra o alcance da erosão provocada pelos vazamentos num trecho próximo do cruzamento com a estrada de ferro. Como solução provisória, os furos resultantes da corrosão foram tapados com pinos de madeira, como pode ser observado na Fig. 6.

Em muitos dos pontos, onde as tubulações foram expostas, observou-se ausência do revestimento externo. Isto foi motivado, provavelmente, pelos danos causados por correntes, talhas ou outros instrumentos empregados durante a sua colocação, ou então, pela ação do solo e das raízes. Além disso, a remoção de alguns pedaços do revestimento do tubo revelou tratar-se de um produto bastante quebradiço e, em certos pontos, esponjoso.

A corrosão, no entanto, manifestou-se de preferência em pontos aparentemente revestidos. O início da corrosão deu-se sob o revestimento e a sua continuação era caracterizada pela formação de uma protuberância do tipo observado na Fig. 7; a quebra do revestimento da protuberância revelou um material amarelado que era o produto da corrosão do tubo e também do próprio revestimento. A remoção deste produto mostrou-se que a corrosão do tubo de aço é do tipo alveolar (pitting corrosion) conforme pode ser observado na Fig. 8 e na Fig. 9; a Fig. 8 apresenta a mesma região da Fig. 7, porém, após a remoção de uma das protuberâncias e do respectivo produto de corrosão. O desenvolvimento da corrosão dos tubos está esquematizado na Fig. 10.

A disposição dos furos na tubulação era, em geral, ao acaso, porém observou-se uma certa predominância deles na parte inferior e lateral. As regiões soldadas, de modo geral, não foram atacadas a não ser em alguns pontos.

c) Ensaio realizados

A fim de verificar-se a agressividade do solo, foi retirada uma amostra do mesmo nas regiões fortemente corroídas e executou-se a determinação do potencial de oxidação-redução. Essa determinação foi feita com referência ao eletrodo de calomelano e apresentou como resultado o valor de 0,268 volts. Starkey e Wight (4) determinaram uma correlação entre o potencial de oxidação-redução de um solo e a correspondente severidade de corrosão, estabelecendo o seguinte critério:

<u>Faixa do potencial de oxidação-redução do solo</u>	<u>Grau de corrosividade</u>
Abaixo de 100 mv	Severo
100 a 200 mv	Moderado
200 a 400 mv	Leve
Acima de 400 mv	Não corrosivo

Desse modo, o valor encontrado classifica o solo da região como sendo levemente corrosivo.

Para verificar o comportamento eletrolítico dos tubos enterrados, determinou-se, em vários pontos da linha adutora no trecho próximo do cruzamento com a estrada de ferro, a diferença de potencial entre o tubo e o solo. Essas determinações foram feitas com auxílio de uma meia célula de (cobre-sulfato de cobre) e de um voltímetro, conforme esquema representado na Fig. 11. Os resultados obtidos estão na Tabela I e correspondem aos pontos indicados na Fig. 4.

TABELA I

Ponto de ensaio	Potencial tubo-solo (volts)	
	Meia célula sobre o tubo	Meia célula a 7 m do tubo
1	- 0,483	-
2	- 0,775	- 0,580
3	- 0,685	Variável com o tempo entre -0,5 e + 2,5
4	Variável com o tempo entre -0,5 e +3,5	

Os resultados nao-variáveis da Tabela I foram obtidos quando o trem nao se achava na linha ou entao estava afastado para o lado da cidade. Já os resultados variáveis com o tempo foram determinados quando o trem percorria os trechos próximos da linha adutora.

A média célula empregada no ensaio foi montada no Instituto de Pesquisas Tecnológicas e está indicada na Fig. 12. A Fig. 13 mostra os seus detalhes construtivos.

A variação com o tempo do potencial tubo-solo provou a existencia de correntes dispersas na regio testada (5). Por outro lado do potencial tubo-solo se tornar menos negativo quando a determinação se fez com a célula afastada do tubo, provou que essa regio era anódica (6).

d) Causas da corrosao

Em face das observações e dos ensaios realizados concluiu-se que os principais causadores da corrosao dos tubos da adutora, nas duas regioes mais fortemente atingidas, foram as correntes dispersas. Estas correntes foram devidas aos geradores da estrada de ferro, pois uma parte da corrente que passava pelos trilhos era desviada pelo solo. Como a condutividade da maioria dos metais é cerca de um bilhao de vezes maior do que a condutividade média dos solos (7), os tubos de aço enterrados atuaram como condutores de baixa resistencia e conduziram a maior parte desviada da corrente dos trilhos. Nestas condições criaram-se regioes catódicas e anódicas ao longo de linha adutora. A Fig. 14 ilustra esquematicamente o fenómeno.

As correntes dispersas nao podem ser consideradas como as únicas responsáveis pela corrosao, no entanto, elas aceleraram-na consideravelmente, principalmente no que se refere a formação de furos. De fato, como se mencionou antes, os furos ocorriam de preferencia em regioes aparentemente revestidas pelo asfalto. Isso foi devido, na realidade, a existencia de pequenas trincas no asfalto que se encarregaram de colocar o aço do tubo em contato com o eletrólito do solo. Essas 5 trincas funcionaram pois, como verdadeiros condutores elétricos, e como a corrente que passou pelos tubos foi aumentada pelas correntes dispersas, a densidade de corrente nas regioes em contato com essas trincas passou a ser bastante elevada, em virtude da pequena área. Desse modo, a corrosao se tornou localizada e rápida.

Apesar do ensaio realizado com uma amostra de solo ter revelado

tratar-se de um solo apenas ligeiramente corrosivo, a sua ação, aliada com a dos demais fatores, foi de considerável monta. Deve-se, principalmente, levar em conta que as regiões mais atingidas pela corrosão localizam-se próxima de lagoas, e que é justificável, pois nestes locais a resistividade do solo é diminuída pela umidade resultante dessa proximidade. Essa baixa resistividade facilitou a circulação de correntes dispersas pelo solo e, em consequência, aumentou a sua agressividade.

Cumpra-se notar que o ensaio realizado com o solo tem significação restrita, uma vez que não computa a influência da umidade e da aeração.

O revestimento asfáltico dos tubos da linha adutora, conforme foi possível observar nos trechos descobertos pela erosão, perdeu a sua continuidade, isto é, tornou-se trincado e deformado. Essa perda de continuidade foi mais acentuada no trecho mais velho da linha adutora e foi devido, principalmente, à ausência de laje de vidro, que normalmente costuma-se adicionar ao asfalto, antes de sua aplicação sobre os tubos, a fim de aumentar a sua resistência às distorções e à formação de trincas. Além disso, a camada de asfalto nesse trecho não foi suficientemente espessa, o que diminuiu a sua resistência à absorção de água (8). A água absorvida pelo revestimento tornou-o esponjoso e quebradiço, e fez com que ele perdesse as suas qualidades protetoras, favorecendo na realidade ainda mais o aparecimento da corrosão alveolar.

e) Medidas sugeridas para eliminar a corrosão

Tendo em vista as causas que promoveram a corrosão dos tubos da linha adutora, sugeriu-se uma das seguintes medidas para eliminar ou, eventualmente, diminuir a corrosão por correntes dispersas:

1. Substituir o solo que circunda os tubos por um material de elevada resistividade elétrica como, por exemplo, areia limpa.
2. Inserir juntas isolantes entre várias porções da linha adutora. Este processo apenas reduziria a corrosão por correntes dispersas, porém, não a eliminaria.
3. Aplicar proteção catódica. Neste caso poder-se-ia promover proteção total da linha desde que se criasse, nos tubos, um potencial mais negativo do que -0,85 volts em relação a meia célula de (cobre)-(sulfato de cobre)(1). Isso pode ser conseguido

através de anodos de sacrificio ou, entao, de geradores de corrente contnua, cuja instalação e dimensionamento exigiram um levantamento completo da resistividade do solo e do potencial tubo-solo ao longo de toda a linha adutora.

4. Ligar os tubos da linha adutora aos trilhos da estrada de ferro. Este método que de todos é o mais acessível, consiste na ligação dos tubos da linha adutora aos trilhos da estrada de ferro, ou entao, se possível, ao polo negativo do Gerador, por meio de um condutor bem isolado, e através de um transformador-retificador, conforme esquema indicado na Fig.15. O sistema deve ser dimensionado para suportar correntes de até 100 amperes (9). Os pontos sugeridos para a ligação entre a linha adutora e a estrada de ferro estão indicados na Fig.3 e são os mais convenientes, pois correspondem aos trechos mais anódicos da linha.

### III CORROSAO EM FRESTAS

#### III.1 Mecanismo da corrosao

A corrosao em frestas ("crevice corrosion") caracteriza-se por um ataque altamente localizado e ocorre nas frestas que resultam do contato de duas peças de materiais diferentes ou de mesmo material. Este tipo de corrosao somente ocorre em presença de um eletrólito que consegue penetrar nas frestas. Como nessas frestas a aeração é pequena, resulta, em consequencia, uma diferente concentração de oxigenio no eletrólito que se encontra dentro das frestas e no eletrólito que se encontra em contato com o material na parte externa. A Fig.16 esquematiza esse fenomeno.

A diferença de concentração em oxigenio desenvolve, na superfície da maioria dos metais e suas ligas, áreas catódicas e anódicas correspondentes, respectivamente, as regioes de alta e baixa concentração em oxigenio. Criam-se, assim, as chamadas "células de concentração de oxigenio" (10) que promovem uma corrosao acentuada de um metal que esteja em contato com a fresta.

A corrosao em frestas ocorre com uma série de metais e ligas em uma grande variedade de meios corrosivos. No entanto, os metais e ligas que apresentam tendencia a passivação, ou seja, formação de uma película fina e aderente de óxido na superfície, são particularmente sensíveis a esse tipo de ataque. É o caso, por exemplo, do alumínio, chumbo e aço inoxidável, entre outros. Nes

tes metais, o empobrecimento de oxigênio destrói o seu "film" protetor, tornando-os quimicamente mais ativos. Assim, quando este empobrecimento é confinado apenas a uma porção da sua superfície, resulta uma diferença de potencial entre a porção que se tornou ativa, e o restante da superfície, que continua passiva, dando origem a chamada "célula ativa-passiva". (11). A ação dessa célula simultaneamente com a de concentração de oxigênio reforça a intensidade de corrosão.

A corrosão em frestas nem sempre ocorre na região de contato. Há casos em que ela se dá na região imediatamente próxima ao contato dos materiais, porém fora das frestas. É o que costuma ocorrer, as vezes, com o cobre e as ligas de alto cobre (11). Neste caso, ocorre uma acumulação de íons de cobre dentro da fresta e resulta uma célula de concentração de cobre, cuja ação é contrária a de uma célula de concentração de oxigênio. Esta célula está esquematizada na Fig.17. Quando a concentração dos íons de cobre atinge um determinado nível, ela se torna mais ativa do que a de concentração de oxigênio e promove a corrosão na região citada.

### III.2 Fatores dos quais depende a corrosão em frestas

A corrosão em frestas, de um metal ou liga, depende de uma série de fatores, entre os quais podem ser citados os seguintes:

- a natureza do material em contato;
- b natureza do eletrólito;
- c pH do eletrólito;
- d espessura da fresta;
- e tensão superficial do eletrólito;
- f vulnerabilidade do metal ou liga em perder a passividade;
- g extensão da área externa as frestas.

#### a Natureza do material em contato

Certos materiais quando em contato com um metal ou liga favorecem mais a sua corrosão do que outros. Assim, são particularmente propícios a corrosão em frestas os seguintes materiais (11): madeira, plásticos, vidro, tecidos, borracha, porcelana, mica, cera, asbestos, organismos marinhos, etc. Materiais que contêm enxofre são, de um modo geral mais danosos do que aqueles que não o contêm. Por exemplo, uma borracha que contém enxofre causa maior corrosão em frestas do que uma livre de enxofre. Trata-se de uma ação suplementar a das células pelo enrique-

cimento do eletrólito em compostos de enxofre.

b Natureza do eletrólito

Os tipos de eletrólitos que promovem a corrosão em frestas são as soluções de sais e de certos ácidos redutores. (11) Entre as soluções de sais merece destaque a de cloreto de sódio, não tanto pela sua agressividade, como pelo fato de ser uma das mais comuns causadoras desse tipo de corrosão. De um modo geral, soluções que apresentam íons halogênicos são apropriadas ao desenvolvimento da corrosão em frestas (15). Em certos casos peculiares esta corrosão pode ocorrer também em presença de soluções de ácidos oxidantes, como por exemplo, ácido nítrico. Contudo, o mecanismo de perda de passividade do metal é, neste caso, distinto.

c pH do eletrólito

A influência do pH do eletrólito sobre a corrosão em frestas depende da natureza do metal ou liga. De um modo geral, metais e ligas ferrosas são mais susceptíveis a corrosão em frestas quando o eletrólito é neutro ou ácido (11). Alumínio e suas ligas são menos susceptíveis a essa corrosão apenas em meio neutro.

d Espessura da fresta

A espessura de uma fresta formada pelo metal e o material em contato varia de um caso a outro, dependendo do estado de acabamento da superfície de cada um deles e do aperto a que ficam sujeitos. Em geral ela é da ordem de centésimos de milímetro ou menos (11). Não é possível estabelecer de um modo completo qual a espessura mais favorável para a corrosão em frestas, uma vez que ela depende de todos os demais fatores. No entanto, uma vez fixados esses fatores, existirá uma espessura ótima para o desenvolvimento da corrosão em frestas, na qual é possível o acesso do eletrólito a fresta. Concomitantemente, essa espessura ótima vai permitir uma grande diferença de concentração de oxigênio.



e Tensao superficial do eletrólito

A influencia da tensao superficial do eletrólito, sobre a corrosao em frestas, está intimamente ligada a espessura das frestas, pois é ela quem estabelece a "molhabilidade" das frestas pelo eletrólito, e por con seguinte, determina as regices que serao atacadas.

f Vulnerabilidade do metal ou liga em perder a passividade

Trata-se da maior ou menor facilidade com que um metal ou liga dá origem a uma "célula ativa-passiva", uma vez que a destruicao do filme protetor, devido ao empobrecimento em oxigenio, nao se dá com a mes ma facilidade em todos eles. Assim, por exemplo, o aço inoxidável AISI 304, é mais vulnerável a perda de passivação do que o aço inoxidável AISI 316, pois neste último, o molibdenio promove a formação de um "film" protetor mais estável do que no primeiro. Por esse motivo o aço AISI 316 resiste melhor a corrosao em frestas está diretamente ligada a extensao da área do metal que está livremente exposta, isto é, que nao está em con tato com o outro material. Quando esta área tende a zero, a corrosao dentro das frestas também tende a zero (12):

### III.3 Corrosao em frestas de chapas de aço inoxidável

a) Generalidades

Como já se mencionou anteriormente, os aços inoxidáveis apresen tam-se particularmente sensíveis a corrosao em frestas em virtude da sua vulnerabilidade em perder a passividade quando ocorre uma diferenca de concentraçao em oxigenio. O caso que passamos a descrever ilustra bem o fenomeno. Trata-se da corrosao em frestas de placas de aço inoxi dável empregadas numa máquina de pasteurizaçao de leite (13).

As placas em questao foram fabricadas a partir de chapas de aço inoxidável AISI 316 e apresentam o aspecto indicado no Fig.18. Na máqui na de pasteurizaçao de leite, as placas sao mantidas em posicao vertical, cada uma apertada contra a outra através de vedaçoes de borracha. Conforme pode ser observado na Fig.18, essas vedaçoes ficam coladas as pla

cas dentro de canaletas periféricas apropriadas. Cada placa apresenta uma das faces em contato com a salmoura, de pH entre 8 e 9 e a temperatura abaixo de 0<sup>o</sup> C. A salmoura é alimentada através de um dos furos existentes nos cantos das placas. A outra face é mantida em contato com o leite, alimentado por um outro furo. A saída, tanto da salmoura como do leite, se dá pelos furos existentes no outro extremo da placa.

Após um certo período de uso, algumas placas foram, em virtude da sua corrosão, substituídas por novas, de fabricação mais recente. Contudo, constatou-se que essas placas novas não estavam apresentando a mesma resistência a corrosão que as antigas. Na Fig. 18, a placa antiga e a placa B uma nova.

A limpeza das placas, antes da colocação das novas, era feita semanalmente. Porém, como as placas novas começaram a apresentar maior corrosão do que as antigas a limpeza passou a ser realizada diariamente.

b) Observação da corrosão

A corrosão foi observada apenas dentro das canaletas que estavam em contato com as borrachas de vedação e no lado que estava banhado pela salmoura. O tipo de ataque foi alveolar ("pitting corrosion"), conforme pode ser observado na Fig. 19. A Fig. 20 mostra uma seção diametral de um desses alvéolos.

c) Ensaio realizados

A fim de identificar os materiais empregados na fabricação das placas foram executados o exame metalográfico e a análise química. O exame metalográfico confirmou que tanto o aço da Placa A como da Placa B apresentavam estrutura austenítica. A análise química deu os seguintes resultados:

	<u>Placa A</u>	<u>Placa B</u>
C	0,10 %	0,10 %
Si	0,61 %	0,52 %
Mn	1,40 %	0,51 %
P	0,037 %	0,031 %
S	traços	traços
Cr	17,4 %	18,3 %
Ni	8,11 %	6,18 %
Mo	2,10 %	2,10 %

A composição nominal de um aço inoxidável AISI 316 é a seguinte:

C, max	0,08%
Mn, max	2,00%
Si, max	1,00%
Cr	16,00 a 18,00%
Ni	10,00 a 14,00%
Mo	2,00 a 3,00%

Verifica-se pois que os aços das duas placas não atenderam as especificações acima no que concerne ao carbono e níquel, principalmente este último, que na Placa B apresentou um valor bastante baixo.

d) Tipo e causas da corrosão

Pelo fato da corrosão observada ter sido alveolar e tendo em vista que a mesma se manifestou em presença de um eletrólito (salmoura) na região de contato entre o aço e a borracha de vedação, conclui-se que trata-se de um caso de corrosão em frestas.

A explicação para a menor resistência a corrosão em frestas da Placa B, quando comparada com a da Placa A, reside provavelmente no seu menor teor em níquel. É sabido que a resistência dos aços inoxidáveis a corrosão normal, por soluções neutras de cloretos, é uma função direta do seu teor em níquel (14) conforme está ilustrado na Fig. 21. Esta resistência pode ser estendida a corrosão em frestas, pois acreditamos que a oposição a perda de passivação varie no mesmo sentido.

Um fato que deve ser levado em consideração, e que, provavelmente, acelerou a corrosão em frestas é o fato de se adotar de executar-se a limpeza diariamente. Enquanto as placas ficavam apertadas uma

contra a outra, a salmoura tinha pequeno acesso as frestas. Porém, quando se desapertava as placas, as frestas se abriam e a salmoura adquiria maior facilidade de acesso e, como as vedações são coladas as placas, não se conseguia eliminá-la completamente durante a limpeza. Desse modo, o aumento das operações de desmontagem do sistema de placas aumentou o tempo de permanência, das regiões cobertas pela borracha, em contato com a salmoura, resultando, em consequência, uma maior corrosão.

e) Medidas sugeridas para debelar a corrosão

A fim de debelar a corrosão em frestas das placas, sugeriram-se as seguintes medidas:

1. Selagem com petrolatos. A aplicação de petrolatos (vaselinas) entre a placa e a vedação de borracha permite manter afastado o eletrólito da região susceptível a corrosão. Poderse-ia empregar outros produtos porém os petrolatos são os mais eficientes (11).
2. Proteção catódica (15). Consistiria em se dispor alguns anodos de sacrifício, como por exemplo, de magnésio ou de zinco, ao longo do eixo dos furos de alimentação e saída da salmoura. Esses anodos devem ficar convenientemente isolados das placas na parte banhada pela salmoura, sendo que a ligação anodo-placa deve ser feita externamente (16).
3. Emprego de inibidores. Alguns compostos adicionados ao eletrólito parecem inibir a corrosão em frestas sendo, no entanto, discutível o seu mérito. Entre eles destacam-se: soda cáustica, carbonato de sódio, sulfato de sódio, sulfato de manganês, bicarbonato de potássio e nitrato de potássio (17).

#### IV CORROSÃO INTERGRANULAR DE AÇOS INOXIDÁVEIS AUSTENÍTICOS

##### IV.1 Introdução

Certos aços inoxidáveis austeníticos ficam, sob certas condições, suscep

tíveis a forte corrosão intergranular, mesmo quando o meio é relativamente pouco agressivo. Esse comportamento anormal ocorre quando os aços, após terem sido solubilizados são aquecidos, durante um certo tempo, dentro de uma determinada faixa de temperatura.

A susceptibilidade a corrosão intergranular pode ocorrer sob diferentes circunstâncias. Assim, por exemplo, durante uma operação de solda de um aço austenítico inoxidável podem surgir áreas que, durante a operação e o resfriamento, permanecem tempo suficiente dentro da faixa crítica de temperaturas, para promover a sua modificação de comportamento ante a corrosão. Do mesmo modo, peças desses aços, empregadas em operações sujeitas a temperaturas que caem dentro da faixa crítica, sofrem o mesmo fenômeno.

Essa mudança de comportamento de um aço inoxidável austenítico, ante a corrosão, é devida a precipitação de certos constituintes nos contornos dos grãos e que ocorre quando o metal é aquecido de modo mencionado. Trata-se da chamada sensitização (18).

Os constituintes que precipitam nos contornos dos grãos são carbonatos complexos de cromo e ferro. A corrosão intergranular não se dá, no entanto, ao longo desses constituintes, e sim ao longo das regiões compreendidas entre o corpo dos grãos e os constituintes precipitados.

Várias teorias foram propostas para explicar o mecanismo da corrosão intergranular dos aços inoxidáveis austeníticos. A mais difundida é a que admite que a diminuição da resistência a corrosão é devida ao empobrecimento em cromo das áreas próximas dos contornos dos grãos. Este empobrecimento é causado pela precipitação dos carbonetos que removem quantidades apreciáveis de cromo dessas regiões, uma vez que se constatou que a relação cromo/carbono nos carbonetos é, aproximadamente, igual a 9. A Fig. 22 esquematiza a variação do teor de cromo ao longo dos grãos e seus contornos. Segundo a teoria em questão, as áreas empobrecidas em cromo perderiam a sua tendência a passivação e, em consequência, ficariam susceptíveis a corrosão. Essa teoria, no entanto, não se aplica aos aços austeníticos de elevado cromo e níquel (por exemplo, 25% Cr e 20% Ni), pois o empobrecimento das áreas vizinhas aos carbonetos não é suficiente para fazê-las perder a sua passivação. Por outro lado, ela também não considera a influência do níquel que, como se verifica praticamente, aumenta a tendência a corrosão intergranular (18).

Uma outra teoria aceita o mecanismo do empobrecimento, porém não considera a perda de passivação como a responsável pela corrosão, e sim a diferença de potencial que resulta da variação da concentração do cromo ao longo do grão. (19) Segundo esta teoria, como o potencial eletroquímico de uma solução sólida de cromo em ferro varia diretamente com o teor de cromo, o núcleo de um grão ficaria

num potencial mais elevado do que a área empobrecida próxima do contorno do grao. Além disso, o próprio carboneto do contorno do grao também apresentaria potencial eletroquímico mais elevado do que o dessa área. Como consequência, a área empobrecida em cromo ficaria anódica em relação aos demais constituintes e portanto, quando em presença de um agente corrosivo, seria a primeira a sofrer ataque químico.

Outras teorias foram propostas para explicar o fenômeno (20). Contudo, ater-nos-emos às acima citadas, pois um alongamento neste assunto fugiria aos propósitos do presente trabalho.

#### IV.2 Fatores que determinam a tendência à corrosão intergranular.

A susceptibilidade dos aços inoxidáveis austeníticos à corrosão intergranular depende da sua tendência à sensitização e esta, por sua vez, depende de uma série de fatores, entre os quais podem ser citados, os seguintes:

1. tempo de permanência dentro da faixa crítica de temperaturas;
2. teor de carbono;
3. tamanho dos grãos;
4. deformação a frio;
5. presença de molibdenio;
6. presença de elemento, com forte afinidade pelo carbono.

##### 1. Tempo de permanência dentro da faixa crítica de temperaturas.

O tempo de permanência durante o qual o aço austenítico inoxidável é mantido dentro da faixa crítica de temperaturas desempenha um importante papel. Com efeito, foi verificado, experimentalmente, que, a uma dada temperatura da faixa crítica, a variação da tendência à corrosão com o tempo de permanência se dá com um máximo, isto é, ela cresce inicialmente, atinge um máximo e depois decresce até o desaparecimento total da corrosão (20). A Fig. 23 ilustra o fenômeno, que pode ser explicado tendo por base a segunda teoria. De fato, a quantidade de carbonetos precipitados aumenta com o tempo e, em consequência, aumenta também a quantidade de cromo retirada do grao. Como a difusão do cromo é mais lenta que do carbono, haverá um empobrecimento em cromo, na região periférica do

grao, sempre mais acentuado e, portanto, uma maior diferença de potencial. Porém, após um certo tempo, a precipitação dos carbonetos alcança o equilíbrio, e, então, a partir desse momento haverá uma difusão nos graos, no sentido de nivelar o seu teor em cromo. Quando isto for alcançado, desaparecerá a diferença de potencial entre o núcleo e a periferia do grao, restando apenas a diferença de potencial entre o grao e os carbonetos do seu contorno. Os carbonetos apresentam um potencial eletroquímico mais elevado do que o grao de modo que este último tornar-se-á anódico. No entanto, sendo a sua área muito grande, relativamente a área dos carbonetos de contorno, a corrosão resultante dessa diferença de potencial se tornará desprezível.

A cada temperatura dentro da faixa crítica corresponde um tempo de aquecimento mínimo  $Z$ , necessário para que o aço se torne susceptível a corrosão intergranular. Esse tempo pode ser correlacionado com a temperatura de aquecimento  $T$  (em graus absolutos) pela seguinte expressão(20):

$$\log Z = \frac{C}{T}$$

onde  $C$  é uma constante do aço. O valor de  $Z$  varia também com a velocidade de resfriamento após a solubilização: quanto mais rápido o resfriamento maior o tempo necessário para um aço austenítico tornar-se susceptível a corrosão intergranular (20). A Fig. 24 indica a variação de  $Z$  com a temperatura de um aço inoxidável austenítico 18/8 resfriado (após a solubilização) de dois modos distintos. A disponibilidade desse tipo de curvas é útil na determinação da soldabilidade dos diferentes aços austeníticos.

Essa variação de  $Z$  com a velocidade de resfriamento (após a solubilização) pode ser explicada tendo em vista que a precipitação de constituintes nos contornos dos graos é um processo de nucleação e crescimento. A passagem, pela faixa crítica de temperaturas, implica no aparecimento de um certo número de núcleos que é tanto maior quanto maior for o tempo de permanência do aço nessa faixa. Assim, um resfriamento mais lento promoverá a formação de um apreciável número de núcleos que, posteriormente, quando do novo aquecimento, já sofreram crescimento.

## 2. Teor de carbono

A susceptibilidade, de um aço inoxidável austenítico a corrosão intergranular, varia, quase linearmente, com o seu teor de carbono (18)(20). Isto é de se esperar, uma vez que o carbono é um dos principais constituintes dos precipitados dos contornos de grao e, portanto, o responsável direto pela sensitização. A Fig. 25 ilustra a variação da corrosão intergranular com o teor de carbono de um aço 18/8. Note-se que, abaixo de 0,03% de

carbono, a corrosão é praticamente desprezível. No entanto, esse valor não pode ser considerado como limite de separação entre a susceptibilidade e não-susceptibilidade a corrosão intergranular, pois o mesmo varia com os demais fatores.

3. Tamanho de grão

Aços inoxidáveis austeníticos com grãos grandes são mais susceptíveis a corrosão intergranular do que aqueles com tamanho de grão pequeno (20). Isso se deve, provavelmente, ao fato de que com o aumento do tamanho de grão a relação entre a área catódica e anódica também aumenta, resultando, em consequência, um aumento de densidade de corrente na área anódica.

4. Deformação a frio

A deformação a frio dos aços inoxidáveis austeníticos, previamente solubilizados, diminui fortemente a sua tendência a corrosão intergranular (20). Uma deformação a frio acima de 15% encoraja-se de "abrir" os planos de escorregamento dentro dos grãos, de modo que, quando o aço for aquecido para dentro da faixa crítica, a precipitação de carbonetos se dará de preferência ao longo desses planos e não dos contornos. Em face disso, resultará uma dispersão dos carbonetos dentro dos grãos com consequente diminuição da susceptibilidade a corrosão intergranular.

5. Presença de molibdenio

Aços inoxidáveis austeníticos, com 1 a 3% de molibdenio, são menos susceptíveis a corrosão intergranular do que os que não o contêm (20). O molibdenio, sendo um componente estabilizador da ferrita, favorece a formação da estrutura austenito-ferrítica no aço. No entanto, a presença de ferrita favorece a precipitação da fase sigma nos contornos de grão que atua de modo semelhante a dos demais precipitados no que se refere a corrosão. Desse modo, a adição de molibdenio a um aço austenítico inoxidável não resolve o problema de sensitização, porém apenas a diminui ligeiramente.

6. Presença de elementos com forte afinidade pelo carbono

A adição de certos elementos aos aços inoxidáveis austeníticos, como por exemplo, titânio, columbio e tántalo (10) (20), aumenta consideravelmente a sua resistência a corrosão intergranular. Esses elementos apresentam uma afinidade pelo carbono maior do que o cromo, de modo que, os carbonetos que precipitam são de preferência desses elementos.



Desse modo, o cromo permanece em soluçao sólida, evitando a formação de gradientes de concentraçao que sao responsáveis pela corrosao intergranular. Pelo fato de conferirem aos aços grande resistencia a corrosao intergranular esses elementos sao chamados de "estabilizadores" e o aço que os contém é chamada "estabilizado".

#### IV.3 Medidas para eliminar a corrosao intergranular.

Quando um aço inoxidável austenítico é utilizado em condições em que ele não sofre aquecimento para dentro da faixa crítica de temperaturas, não há necessidade de nenhuma medida no sentido de eliminar a sua susceptibilidade a corrosao intergranular, sendo suficiente apenas um tratamento de solubilizaçao na faixa de temperaturas de 1050 a 1100°C, seguido de resfriamento brusco. A solubilizaçao encarrega-se de dissolver todos os carbonetos de contorno e o resfriamento brusco evita a sua re-precipitaçao (18). No entanto, estes tratamentos térmicos não podem ser aplicados a peças grandes, ou, então, peças que não possam tolerar escamas e empenamentos que ocorrem nesses tratamentos.

Para esse tipo de peças, e para peças que são aquecidas para dentro da faixa crítica, há necessidade de se adotar uma ou uma combinaçao das seguintes medidas:

1. Reduzir o teor de carbono ao mínimo possível.
2. Manter um pequeno tamanho de grão.
3. Promover deformaçao a frio após a solubilizaçao e depois aquecer para dentro da faixa crítica no sentido de promover a precipitaçao dos carbonetos ao longo dos planos de escorregamento.
4. Aquecer a peça dentro da faixa crítica, longe de agentes corrosivos, por tempo suficiente para promover a homogeinizaçao do cromo dentro dos grãos.
5. Adicionar ao aço elementos estabilizantes (titanio, colúmbio e tántalo).

De todas essas medidas, as mais largamente utilizadas são a primeira e a última.

#### IV.4 Exemplos: Dois casos de corrosão intergranular

##### IV.4.1. Corrosão de um tubo de aço inoxidável empregado na proteção de uma resistência elétrica

Trata-se de um caso de corrosão intergranular ocorrido com um tubo de aço inoxidável AISI 316 utilizado na proteção de uma resistência elétrica (21). Esse tubo trabsihou mergulhado, até sofrer ruptura, num banho de sal fundido de um forno de tratamentos térmicos, durante cerca de 20 horas. A temperatura do trabalho do banho era em média de 270° C. O sal era um combinação de nitrito de sódio, nitrato de sódio e nitrato de potássio e continha, além disso, quantidades apreciáveis de cloretos.

O exame do tubo permitiu verificar que a sua corrosão foi generalizada em toda a superfície externa, que estava em contato com o banho. A corrosão foi tipicamente intergranular, conforme pode ser observado nas Figuras 26 e 27. A Fig. 27 mostra, além disso, presença de carbonetos em contorno de grão que, na realidade, não estão muito nítidos em virtude do baixo teor de carbono do aço.

Em face do exposto conclui-se que se trata de um caso de sensibilização do aço. Encontrando um meio razoavelmente corrosivo, uma vez que os cloretos constituíam parcela apreciável dentro do sal, e tendo em vista a temperatura de trabalho, o tubo sofreu forte corrosão, chegando a ruptura. Deve-se notar que, apesar da temperatura de trabalho do banho ter sido de 270° C, a temperatura do tubo foi consideravelmente superior, em virtude do gradiente térmico que ocorreu nessas condições.

##### IV.4.2. Corrosão de um anel de aço inoxidável utilizado num equipamento químico

Trata-se de um caso de sensibilização devida a solda, ocorrido com um anel de aço inoxidável austenítico AISI 302. (22) Este anel apresentava duas soldas longitudinais e trabalhava em contato com ácido sulfúrico em equipamento químico.

A corrosão desenvolveu-se apenas nas regiões vizinhas as soldas, conforme pode ser visto na Fig. 28, e, além disso, foi tipicamente intergranular, segundo mostra a Fig. 29. A precipitação de carbonetos nos contornos dos grãos foi confirmada por exame metalográfico.

## V. FRATURA POR CORROSAO SOB TENSAO

### V.1. Características gerais

Se um metal ou liga está submetido a uma tensão de tração estática considerável, num meio agressivo, podemos ter simplesmente uma aceleração do processo corrosivo. Entretanto, em certas condições, pode dar-se o aparecimento de um fenómeno de características diferentes, que recebe o nome de "fratura por corrosão sob tensão" ("stress corrosion cracking"). Este fenómeno se caracteriza pelo aparecimento e posterior desenvolvimento de trincas que conduzem a ruptura do metal.

O tempo necessário para que haja a ruptura depende da tensão de tração aplicada, da agressividade do meio e da liga utilizada.

A corrosão sob tensão assume características próprias para cada liga e para cada meio corrosivo. Podemos enumerar, entretanto, características comuns a todos os casos:

1. A fratura causada pela corrosão sob tensão, em geral, não apresenta estrição e o aspecto é semelhante do dado por fadiga. Com a propagação progressiva da trinca resulta uma diminuição na secção resistente até ser atingido o limite de resistência do material. Desse modo, aparecem na fratura duas zonas distintas: a primeira, mais lisa, correspondendo a trinca propagada e a segunda, de aspecto rugoso e grosseiro, correspondendo a ruptura brusca.
2. A corrosão sob tensão só se manifesta quando há a ação simultânea de considerável tensão de tração e de um meio corrosivo. Isto significa que não haverá ruptura se mantivermos sob tração, em meio não corrosivo, um material previamente corroído (23).
3. Tensões de compressão não causam rupturas. Ao contrário, a introdução de tensões de compressão na superfície de um metal ou liga pode prevenir o trincamento devido a corrosão sob tensão.
4. As rupturas podem ser devidas tanto as tensões internas residuais quanto as tensões externas aplicadas.
5. As trincas podem ser intergranulares, transgranulares ou mistas. Uma trinca originada por um processo corrosivo intergranular terá um desenvolvimento predominantemente intergranular. Por outro lado um ataque corrosivo, que se dá no corpo do grão, dará uma trinca de desenvolvimento

vimento transgranular (24).

6. A corrosão é, em geral, altamente localizada. Isto significa que podemos ter peças trincadas ou rompidas por corrosão sob tensão sem que a superfície das mesmas denote evidência de processo corrosivo generalizado.
7. As trincas se desenvolvem perpendicularmente à direção do esforço de tração.
8. Em muitos casos tem-se observado a existência de uma tensão mínima abaixo da qual não se verificam rupturas num tempo finito bastante grande (Fig. 30).

## V.2. Mecanismo do trincamento por corrosão sob tensão

O aparecimento e a propagação de trincas num material metálico, corroído sob tensão, é um fenômeno complexo resultante de ações mecânicas e eletroquímicas simultâneas.

As tensões mecânicas, além de serem diretamente responsáveis pela propagação da trinca e consequente destruição dos materiais, modificam também o seu comportamento eletroquímico.

Para explicarmos o mecanismo do trincamento por corrosão sob tensão devemos considerar cada um dos dois estágios em que se pode dividir o processo, a saber, a formação da trinca e a sua posterior propagação.

### a) Formação da trinca

A formação da trinca se deve a um ataque corrosivo localizado. Este ataque pode se dar em:

1. áreas anódicas nos contornos de grão que são devidas à presença de precipitados, ao alto acúmulo número de defeitos cristalinos ou à concentração de tensões;
2. Pontos de ruptura do filme superficial de óxido;
3. áreas anódicas devidas à deformação plástica, podendo se ter inclusive a precipitação de fases meta-estáveis;

4. áreas de contornos sub-estruturais nas quais podemos ter uma segregação de átomos de soluto ou acúmulo de defeitos cristalinos (25)(26).

b) Propagação da trinca

A propagação da trinca tem como explicação mais plausível uma teoria mecânica. A concentração de tensões no fundo de uma fissura inicialmente formada pode provocar, em certos pontos, a deformação plástica com a consequente propagação da trinca. A deformação plástica provoca ainda a ruptura do filme protetor. O meio corrosivo que penetra na fissura acelera a propagação da trinca. Assim, se por qualquer motivo for interrompida a propagação, o ataque corrosivo no interior da fissura reiniciará o processo. As trincas maiores possuem tendência de se propagarem mais rapidamente que as menores. Assim que uma trinca se torna dominante ela interrompe o desenvolvimento de outras.

A velocidade de propagação de uma trinca aumenta em progressão geométrica com o tempo (Eq. 31)(26).

### V.3 Exemplo: Corrosão sob tensão de barras protendidas.

Com a generalização do emprego de concreto protendido na construção civil, um bom número de casos de rupturas de barras, devidas a corrosão sob tensão, tem surgido, uma vez que as barras das armaduras são empregadas sob tensões de tração próximas do limite de escoamento. Nestas condições um meio mais agressivo poderá causar graves danos à estrutura. É o caso do concreto que contém cloreto de cálcio como acelerador da pega. Este componente tem se revelado um agente danoso na corrosão sob tensão(27).

A presença de nitratos também tem provocado o fenômeno (29).

O gás sulfídrico é mais drástico, devido à difusão de hidrogênio no retículo, provocando assim fragilização localizada (28).

A proteção imperfeita da barra ou arame pelo concreto pode também favorecer forte ataque corrosivo.

Além das condições do meio, influem também sobre a resistência do material a natureza e tratamento do mesmo. Assim, material temperado é em geral

sensível a corrosão sob tensão (30). Por outro lado, barras encruadas e aliviadas de tensão possuem melhor resistência (27).

Passaremos a descrever, em seguida o caso de arame empregado na armadura de tubo protendido na segunda adutora de Ribeirão das Lajes e que foi enviado ao I. P. T. para determinação da causa de fratura (31).

Este arame foi aplicado sob tensão, sobre uma camisa de aço, que por sua vez revestia um tubo de concreto com espessura média de 6 cm. O tubo tinha o diâmetro de 1,75m e o arame era aplicado em espiral em torno dele. Nas extremidades o arame era preso por meio de luvas que eram soldadas a camisa. As emendas, quando necessárias, eram feitas através de luvas especiais. Os tubos assim protendidos eram revestidos externamente por uma argamassa a fim de proteger a camisa e o arame contra a corrosão. A Fig. 32 mostra um desses tubos com argamassa parcialmente removida.

As rupturas tiveram início depois dos tubos estarem em serviço por mais de 4 anos e se deram no trecho de pressão máxima da linha (80 m de água). O aspecto das fraturas resultantes encontra-se na Fig. 33.

Nas amostras recebidas constatou-se que certas porções do arame eram francamente quebradiças e se rompiam ao serem dobradas, enquanto que outras suportavam flexão manual forte.

Na fratura, a região correspondente a tração é escura (devido a corrosão) enquanto que a região rompida bruscamente por flexão é mais brilhante.

Uma porcentagem muito pequena do arame rompeu com estrangulamento pronunciado, característico de material tenaz rompido por tração, com pequeno alongamento e grande estricção.

Observações preliminares feitas com lupa ao longo de numerosas amostras do arame pertencentes aos tubos rompidos, revelaram a existência de trincas transversais, conforme pode-se observar nas Figuras 34 e 35. A Fig. 35 apresenta detalhes de duas trincas da Fig. 35.

As observações, feitas nos tubos rompidos, revelaram que nos locais em que a ruptura do arame provocou a fissuração da argamassa protetora, o arame se apresentava enferrujado. Entretanto, em outros locais, onde a ruptura do arame não provocou a fissuração da argamassa, não foi notada a presença de ferrugem a não ser na seção da fratura.

O exame micrográfico do material revelou tratar-se de aço temperado e revenido, não denotando qualquer anomalia.

Se o arame já estivesse trincado quando da sua aplicação dificilmente teria resistido a protensão e mais 4 anos de trabalho. Portanto, do acima exposto conclui-se que as trincas surgiram no material depois de instalado. Tendo em vista que o arame estava submetido a considerável tensão de tração e que as evidências apresentadas denotaram a possibilidade de um ataque corrosivo, conclui-se que as trincas surgiram e se propagaram devido ao fenômeno de corrosão sob tensão.

## REFERENCIAS

1. J. H. Morgan - Cathodic Protection. Leonard Hill (Books) Ltd., 1959, pág. 253-273.
2. W. A. Wesley and R. H. Brown - Fundamental Behavior of Galvanic Couples. The Corrosion Handbook, H. H. Uhlig (ed.), John Wiley & Sons Inc., 1948, pág. 481-483.
3. Instituto de Pesquisas Tecnológicas - Relatório Nº 3637-1964.
4. R. L. Starkey and K. M. Wight - Anaerobic Corrosion of Iron in Soils. Final Report of the American Gas Association Corrosion Research Fellowship, Monograph, Monograph Am. Gas. Assoc., 1945.
5. B. Husock - Use of Pipe-to-Soil Potential in Analyzing Underground Corrosion, v.17, Nº 8, Aug. 1961, pág. 391-395 t.
6. Op. Cit (1), pág. 22-23.
7. S. P. Ewing - Corrosion by Stray Currents. The Corrosion Handbook, H. H. Uhlig (ed.), John Wiley & Sons Inc., 1948, pág. 601-606.
8. M. Romanoff - Underground Corrosion. National Bureau of Standards Circ. 579, pág. 132. 1957
9. L. M. Applegate - Cathodic Protection. McGraw Hill Book Co., Inc. pag. 217
10. R. J. McKay - Common Occurrence of Corrosion by Electrolytic Concentration Cells. Ind. Eng. Chem., v.17. 1925, pág. 23-24.



11. E.H. Wyche, L.R. Voight and F. L. LaQue - Corrosion in Crevices. Transactions of The Electrochemical Society, v. 89, 1946, pág.149-166.
12. O.B. Ellis and F. L. LaQue - Area Effects in Crevice Corrosion. Corrosion v.7, nº11. Nov. 1951, pág.362-364.
13. Instituto de Pesquisas Tecnológicas - Relatório Nº 3625 - 1963.
14. C.A. Zapffe - Stainless Steels. The American Society for Metals, 1949, pág.41-43.
15. T. P. May and H.A. Humble - Effectiveness of Cathodic Currents in Reducing Crevice Corrosion and Pitting of Several Materials in Sea Water. Corrosion, v.8, Nº2, Feb.1952, pág.50-56.
16. Op. Cit (1) - pág.214-252.
17. R. Franks - Chromium-Nickel Austenitic Stainless Steels. The Corrosion Handbook, H.H.Uhlig (ed.), John Wiley & Sons Inc., 1948, pág.150-165.
18. Op. Cit. (12) - pág.43-58.
19. V. Cihal and M. Prazak - A Contribution to the Explanation of Intergranular Corrosion of Chromium-Nickel Steel. Corrosion, v.16, nº10 Oct.1960, pág.530-532 t.
20. G. L. Shvartz and M. M. Kristal - Corrosion of Chemical Apparatus. Consultants Bureau, Inc. 1959, pág.93-123.
21. Instituto de Pesquisas Tecnológicas - Relatório Nº 3627 - 1962.
22. Instituto de Pesquisas Tecnológicas - Certificado Oficial Nº 83134 - 1949.
23. V.V. Romanov - Stress Corrosion Cracking of Metals. Israel Program for Scientific Translations, 1961, pág.1-5.
24. J. J. Harwood - The Phenomena and Mechanism of Stress Corrosion Cracking. Stress Corrosion Cracking and Embrittlement, W.D. Robertson (ed.), A Symposium Arranged by the Corrosion Division of The Electrochemical Society (1954), John Wiley & Sons., Inc. pág.3-4.

25. Op. Cit. (23) - pág.29-34.
26. Op. Cit. (26) - pág.10-19.
27. J.H.Godfrey - Corrosion Tests on Prestress and Concrete Wire. Corrosion, v.17, nº4, April 1961, pág.24.
28. W.Grundig - A Fragilizaçao pelo hidrogenio como causa de ruptura de arame de aço para protender concreto. Boletim da Associação Brasileira de Metais, v.14 nº53, Out.1958, pág.473-515.
29. R. L. McGlasson, W. D. Greathouse, C. M. Hidgins - Stress Corrosion Cracking of Carbon Steels in Concentrated Sodium Nitrate. Corrosion, v.16, nº11, Nov.1960, pág.557 t.
30. Op. Cit (20) - pág.46-49.
31. Instituto de Pesquisas Tecnológicas - Relatório Nº 2134 (1953).

#### Referencias Siplementares

##### I - Corrosao por correntes dispersas

1. U.R.Evans - The Corrosion and Oxidation of Metals: Scientific Principles and Practical Applications. Edward Arnold (Publishers) Ltd., 1961, pág.264-268.
2. O.W.Zastrow- Corrosion Problems In Rural Power Distribution, Corrosion, v.7, nº9, Sept.1951, pág.308.
3. L.Horvath, H.E.Nerhood, S. M. Seidman and R. H. Travers - Isolation of Trolley Bus Negative Return To Prevent Stray Current Corrosion, v.8, nº6, June 1952, pág.205-211.

4. L.W.Ewing Jr. - Installing a Large Diameter Products Pipe Line Through a Heavily Industrialized Area. Corrosion, v.10, n<sup>o</sup>10, Oct. 1954, pág.315-317.
5. R.H.Pope - Corrosion, by Stray Currents. Corrosion, v.10, n<sup>o</sup>10, Oct. 1954, pág.324.
6. R.H.Pope - Passing of the Stray Current Problem. Corrosion, v.10, n<sup>o</sup>11 Nov.1954, pág.420.
7. F.W.Ringer - Solution of Cathodic Protection Interference Problems; Corrosion, v.11, n<sup>o</sup>3, March 1955, pág.131-138 t.
8. W.S.Woodward - Two Cases of Corrosion in Suburban New York Disguised as Galvanic - Their Cause and Mitigation, v.12, n<sup>o</sup>9, Sept. 1956, pág.427-432 t.
9. K.G.Compton - Sources of Underground Corrosion Potential Differences - Corrosion, v.16, n<sup>o</sup>2, Feb.1960 pág.43-46t.
10. E.U.Thalmann - New Developments in the Mitigation of Corrosion in the Utility Field. Corrosion, v.16, n<sup>o</sup>11, Nov.1960, pág.543-552t.
11. O.Handerson - Methods and Experience in Underground Cathodic Protection: Lead Sheathed Communication Cables (Part 1). Corrosion, v.17, n<sup>o</sup>1, Jan 1961, pág.45-46t.
12. P.P.Skule - Methods and Experience in Underground Cathodic Protection: Gas Transmission and Distribution Lines (Part 3). Corrosion v.17, n<sup>o</sup>1, Jan 1961, pág.48-49t.
13. S.Fukuta, S.Kondo, N.Usami and S.Sekimoto - Design for Prevention of of Pipe Line Corrosion Based on Survey of Ground Potential Distribution. Corrosion, v.17, n<sup>o</sup>1, Jan 1961, pág.50-52t.
14. D.O.Sprows and M.E.Carlisle Jr. - Resistance of Aluminum Alloys To Underground Corrosion, v.17, n<sup>o</sup>3, March 1961, pág.125-132t.
15. K.G.Compton - Factors Involved in Corrosion of Lead Cable Sheath. Corrosion, v.17, n<sup>o</sup>8, Aug.1961, pág.409-412 t.
16. G.V.Akimov - Factors Influencing Corrosion, v.15, n<sup>o</sup>9, Sept.1959, pág.455-468 t.

17. J. C. Vogt - Engineering and Economic Problems Involved in Cathodic Protection of Laclede Gas System. *Materials Protection*, c.1, nº2, Feb.1962, pág.34-37.
18. A. W. Peabody - Pipeline Corrosion Survey Techniques. *Materials Protection*, v.1, nº4, April 1962, pág.62-76.
19. E. C. Paver - Stray Current Drainage Switch for Gas Distribution System. *Corrosion*, v.12, nº12, Dec.1956, pág.593-594t.
20. E. P. Teale - Corrosion Control System for Underground Cables in Conduit in a Stray Current Area. *Corrosion*, v.13, nº3, March 1957, 165-172t.
21. V. B. Pike - A New Electrolysis Switch For Underground Lead Sheath Cable Drainage Systems. *Corrosion*, v.7, nº10, Oct.1951, pág.1.
22. V. B. Pike - An Improved Electrolysis Switch. *Corrosion*, v.8, nº9, Sept. 1952, pág.311-313.
23. G. H. Cantwell - Artificial Insulating Joints for Stray Current Mitigative Measurements. *Corrosion*, v.13, nº10, Oct.1957, pág.616-618t.
24. R. E. Francis and L. S. Birnbaum - Automatic Control of a Platinum Anode Cathodic Protection System. *Corrosion*, v.17, nº1, Jan. 1961, pág.20-22.

## II - Corrosao em frestas

25. U. R. Evans - The Corrosion and Oxidation of Metals: Scientific Principles and Practical Applications. Edward Arnold (Publishers) Ltd. 1961, pág.207-212-528.
26. J. Arnott - Contact Corrosion of Stainless Steel. *Metallurgia*, v.19, nº114, April 1939, pág.223-224.
27. K. M. Huston and R. B. Teel - Some Observations of the Potentials of Stainless Steels in Flowing Sea Water. *Corrosion*, v.8, nº7, July 1952, pág.251-256.
28. E. V. Kunkel - Selecting Gaskets to Limit Corrosion of Stainless Steel

Bolted Joints In a Chemical Plant. Corrosion, v.10, n<sup>o</sup> 8  
Aug.1954, pág.261.

29. J. A. Collins - Effect of Design, Fabrication and Installation on the Performance of Stainless Steel Equipment. Corrosion, v.11 n<sup>o</sup> 1, Jan. 1955, pág.11-18t.
30. D. J. de Paul - Corrosion Engineering Problems in High Purity Water, Corrosion, v.13, n<sup>o</sup> 1, Jan. 1957, pág.75-80t.
31. F. L. LaQue - Theoretical Studies and Laboratory Techniques in Sea Water Corrosion Testing Evaluation. Corrosion, v.13, n<sup>o</sup> 5, May 1957, pág.303-314t.
32. A. J. Freedman and A. Dravnieks - Evaluation of Refinery Corrosion Inhibitors. Corrosion, v.14, n<sup>o</sup> 12, Dec.1958, pág.567-570 t.
33. K. R. Walston and A. Dravnieks - Corrosion of Refinery Equipment During Acid Cleaning. Corrosion, v.14, n<sup>o</sup> 12, Dec.1958. pág.571-577 t.
34. J. M. Turnbull - Salt Refinery Corrosion Caused by Varying Evaporator Conditions. Corrosion, v.16, n<sup>o</sup> 7, July 1960, pág.11-16.
35. L. W. Gleckman and R. K. Swandby - Massive De-Aluminization of Aluminum Bronze by Chloride Crevice Attack. Corrosion, v.17, n<sup>o</sup> 3, March 1961, pág.144-148t.
36. W. M. Scott - Calcium Sulfate Scale Causes Corrosion of Stainless Steel Pulp Digesters. Corrosion, v.17, n<sup>o</sup> 6, June 1961, pág.14-18.
37. R. Benes, F. J. Holsinger and R. E. Pierson - Corrosion in the Corn Wet Milling Industry. Corrosion, v.15, n<sup>o</sup> 3, March 1959, pág.113-116t.
38. H. P. Godard - Galvanic Corrosion Behavior of Aluminum in the Atmosphere. Materials Protection, v. 2, n<sup>o</sup> 6, June 1963, pág.38-47.

III - Corrosao Intergranular de Aços Inoxidáveis Austeníticos

39. American Society for Metals - Metals Handbook, vol.1, Properties and Selection of Metals, 8a.ediçao, 1961, pág.565, 590-591.
40. J.A. Levin (ed.) - Intercristalline Corrosion and Corrosion of Metals under Stress. Consultants Bureau, 1962, pág.25-158.
41. M. L. Holzworth, F. H. Beck and M. G. Fontana - The Mechanism of Knife-Line Attack In Welded Type 347 Stainless Steel. Corrosion, v.7, nº12, Dec.1951, pág.441-449.
42. G.A. Works - A Case History Involving Intergranular Failure of Stainless Steel Heater Tubes. Corrosion, v.8, nº6, June 1952, pág. 217-221.
43. J.J. Heger and J. L. Hamilton - Effect of Minor Constituents on the Intergranular Corrosion of Austenitic Stainless Steels. Corrosion, v.11, nº1, Jan.1955, pág.6-10t.
44. A.J. Freedman, G.F. Tisnai and E.S. Troscinski - Selection of Alloys For Refinery Processing Equipment, Corrosion, v.16, nº1, Jan 1960, pág.19-23t.
45. D. Warren - Corrosion and Weldability Studies on Chromium-Manganese Austenitic Stainless Steels. Corrosion, v.16, nº3, March 1960, pág.119-130t.
46. J.E. Prior - Corrosion of Valve Seat Ring Results in Flexible Metal. Corrosion, v.15, nº1, Jan 1959, pág.1 t.
47. A.C. Hamstead and L.S. Van Delinder - Comparative Corrosion Resistance of 200 and 300 Series Stainless Steels in Chemical Manufacturing Processes. Corrosion, v.15, nº3, March 1959, pág. 147-157t.
48. D. Warren - The Effect of Sigma Phase vs. Chromium Carbides on the Intergranular Corrosion of Rype 316 and 316L Stainless Steel. Part 1: Corrosion, v.15, nº4, April 1959, pág.213-220t. Part 2: Corrosion, v.15, nº5, May 1959, pág.221-232t.
49. U.R. Evans - Corrosion in Relation to Welding. Corrosion Technology, v. 1, nº5, July 1954, pág.136-140.

50. NACE Technical Committee Report - Cathodic Protection of Process Equipment, Publication 59-9; Corrosion, v.15, nº3, March 1959, pág.123-124t.

IV - Fratura por Corrosao sob Tensao

51. R. B. Mears, R. H. Brown and E. H. Dix Jr. - A Generalized Theory of Stress Corrosion of Alloys. Symposium on Stress Corrosion Cracking of Metals, ASTM-AIME, 1944, pág.323-344.
52. R. E. Pollard - Stress Corrosion Tests of Bridge-Cable Wire. Symposium on Stress Corrosion Cracking of Metals, ASTM-AIME, 1944 pág.437-957.
53. I. Connet - Corrosion of Prestressed Concrete Tanks. Materials Protection v.3, nº1, Jan.1964, pág.90-100.
54. A. H. S. Feijó, M. C. M. Silva, A. C. Cantição, E. G. Andrade e H. L. Radino - O Acidente da Segunda Adutora de Ribeirao das Lajes. Boletim da Associação Brasileira de Metais, v.9, nº32, Julho 1953, pág.382.
55. W. O. Everling - Stress Corrosion in High Tensile Wire. Wire and Wire Products, v.30, nº3, March 1955, pág.316.
56. F. Schwier - Stress Corrosion and Relaxation of High Carbon Steel Wire for Prestressed Concrete. Wire and Wire Products, v.30, nº12, Dec.1955, pág.1473-9, 1519-21.

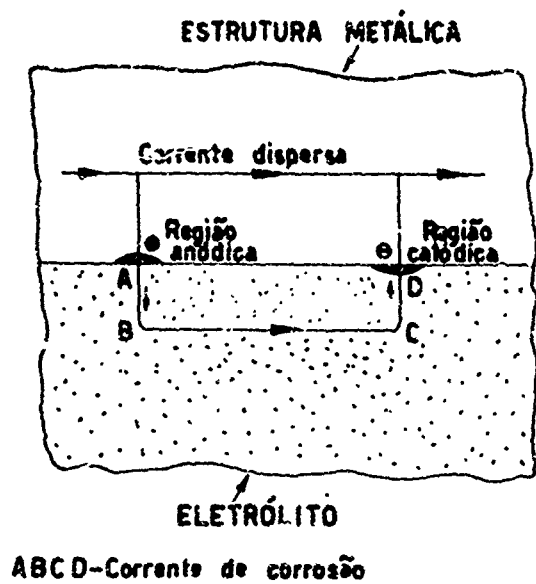

FIG.1

Esquema do mecanismo da corrosão por correntes dispersas que passam pela estrutura.

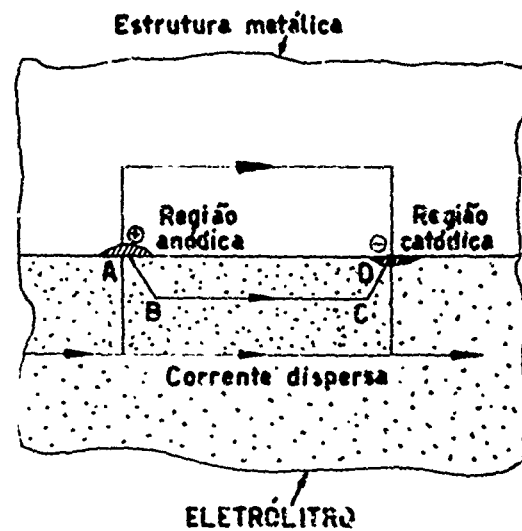

FIG. 2

Esquema do mecanismo da corrosão por correntes dispersas que passam pelo eletrólito.

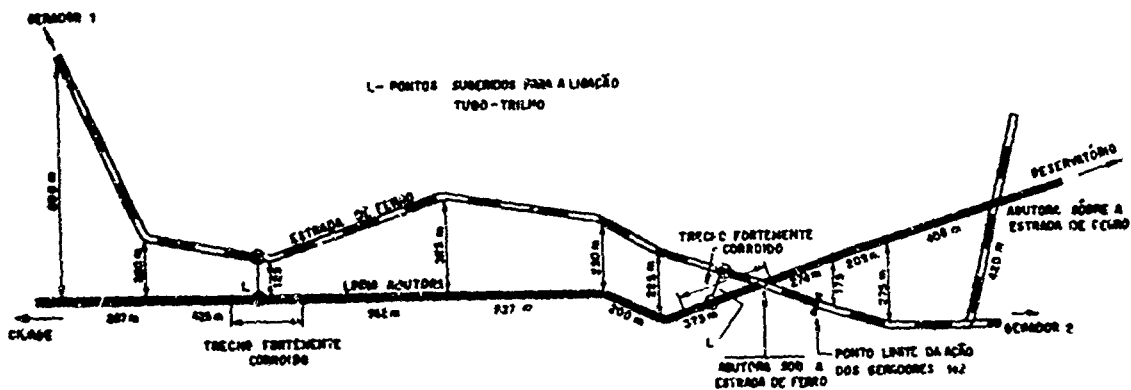

FIG. 3

Disposição da estrada de ferro em relação à linha adutora.



Esquema do perfil da linha adutora de água na região em que se observou a corrosão mais intensa.



FIG. 4

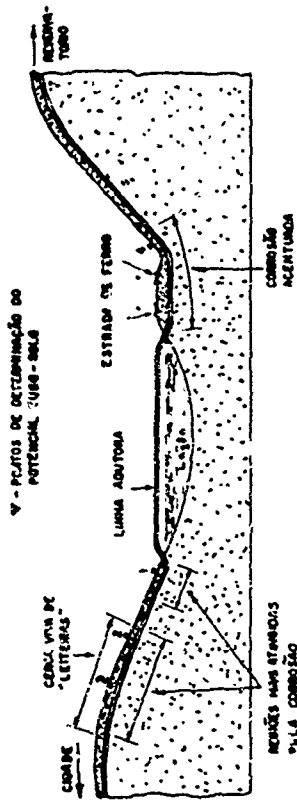

FIG. 5 Aspecto da erosão causada pelo vazamento de água através dos furos provocados pela corrosão. Observe-se o jato de água que sai por um furo destapado.

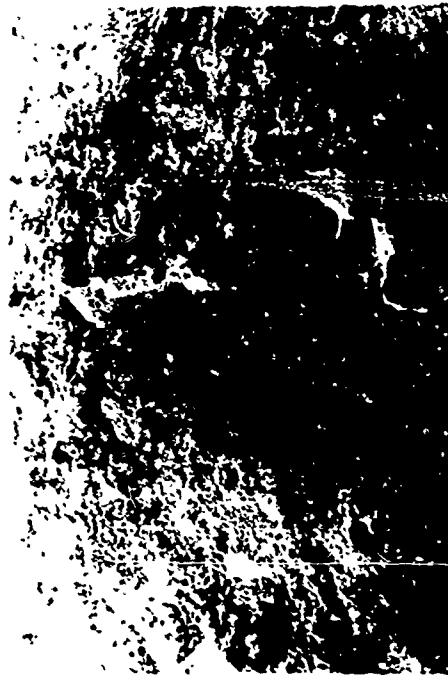

FIG. 6 Furo causado pela corrosão e tapado com um pino de madeira.

FIG. 6



FIG. 7

Protuberâncias causadas na camada asfáltica externa pela corrosão alveolar.



XVI - 43

FIG. 8 Mesma região da Fig. 7 após a remoção da camada asfáltica externa de um dos alvéolos e do produto de corrosão nele contido.



FIG. 9

Aspecto da corrosão alveolar bem avançada em três pontos próximos. O alvéolo da direita localiza-se na parte superior do tubo colocado horizontalmente. Os outros dois estão na mesma secção transversal. O revestimento asfáltico foi removido a fim de melhor observar-se a corrosão.

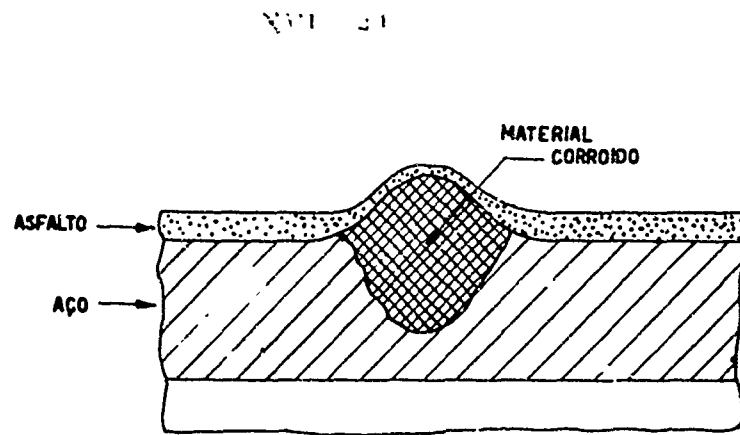

FIG. 10 Esquema de um alvéolo de corrosão.

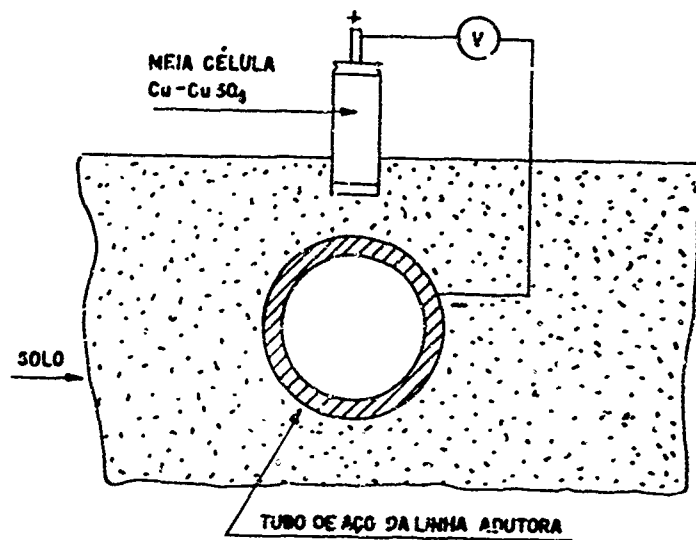

FIG. 11 Esquema da disposição utilizada para a determinação do potencial tubo-solo.

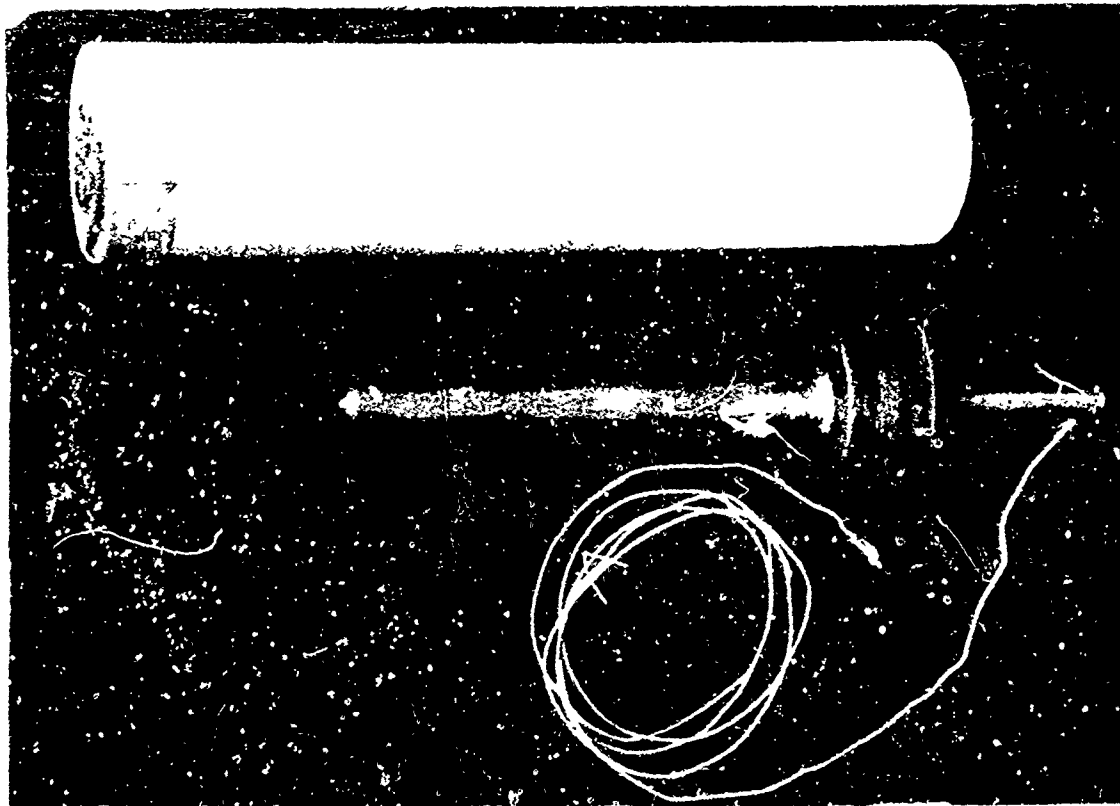

FIG.12 Meia célula de (cobre)-(sulfato de cobre)

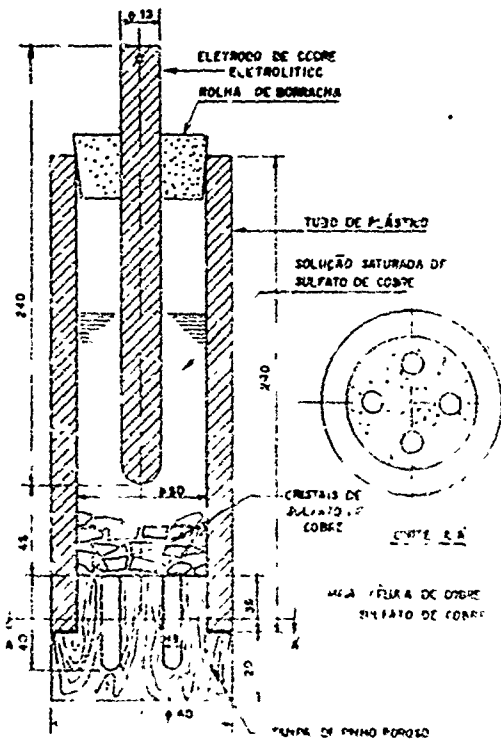

FIG.13 Desenho da meia célula de (cobre)-(sulfato de cobre)

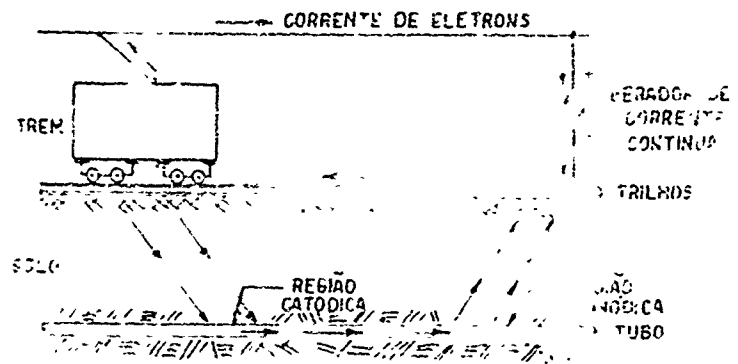

FIG.14 Esquema da situação que dá origem à corrosão por corrente contínua das tubos enterrados.

FIG. 15

Esquema da ligação tubo-trilho com em-  
prêgo de um transformador-retificador.  
(Ref. (1), pág. 263).

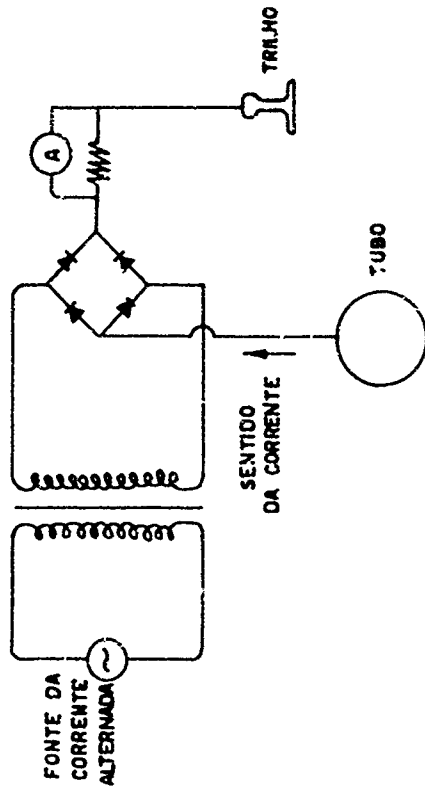

FIG. 16 Ilustração da formação de uma célula de  
concentração de oxigênio devida ao conta-  
to entre dois materiais em presença de  
um eletrólito.

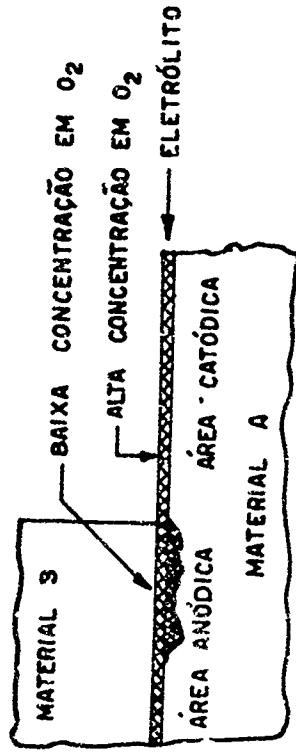
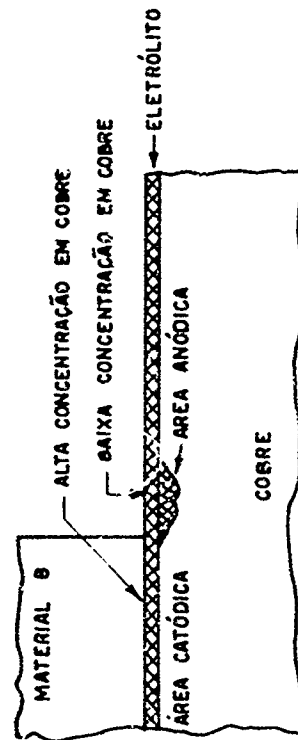

FIG. 17

Corrosão em frestas devida à formação  
de uma célula de concentração de cobre.



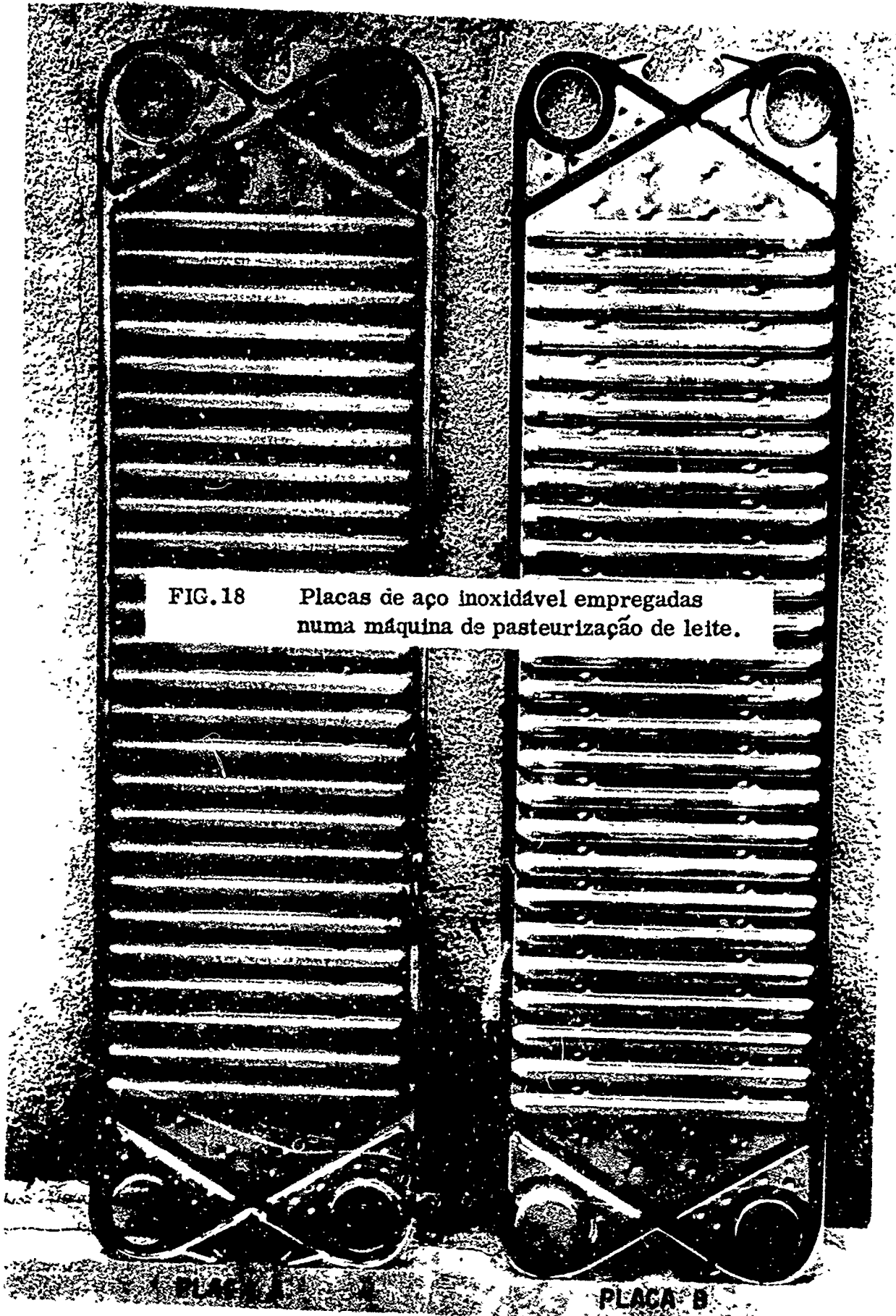

FIG. 18 Placas de aço inoxidável empregadas numa máquina de pasteurização de leite.

PLACA A

PLACA B

XVI - 45

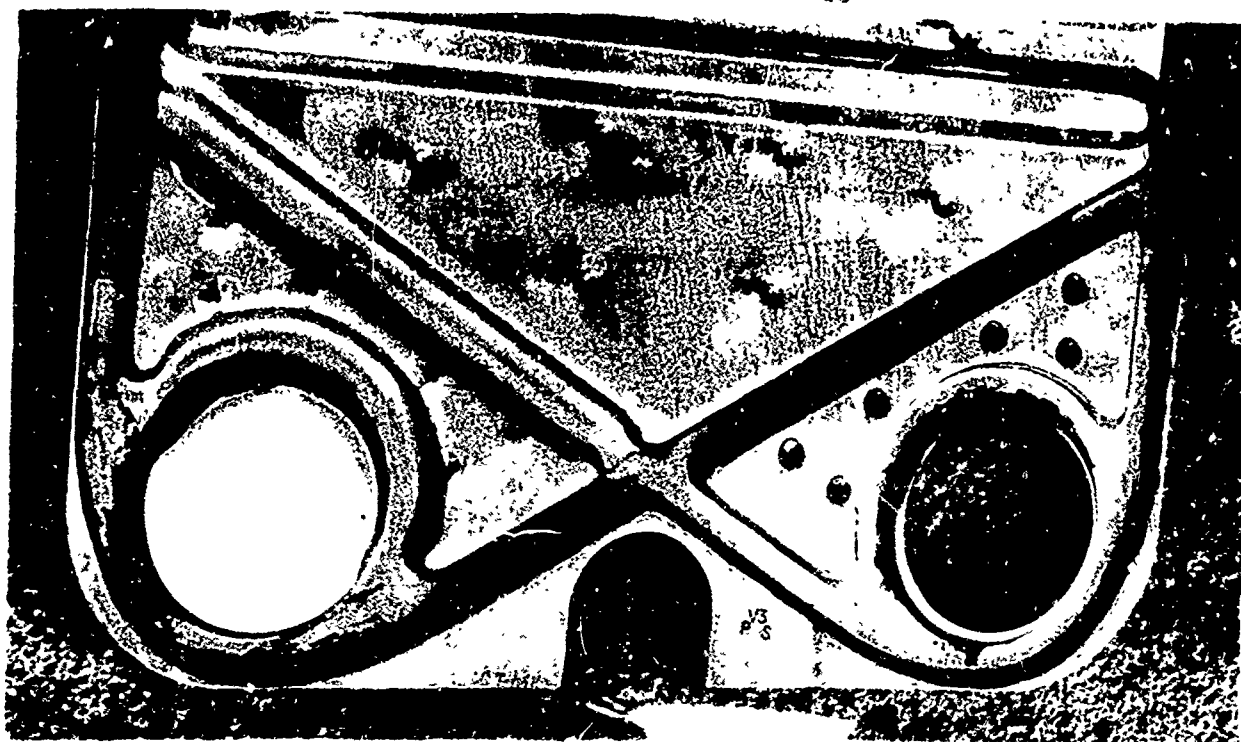

FIG. 19 Corrosão alveolar dentro da canaleta  
circundante do furo de alimentação da  
salmoura.



FIG. 20 Secção diametral de um alvéolo da Fig. 19  
Ampliação de 50 diametros.

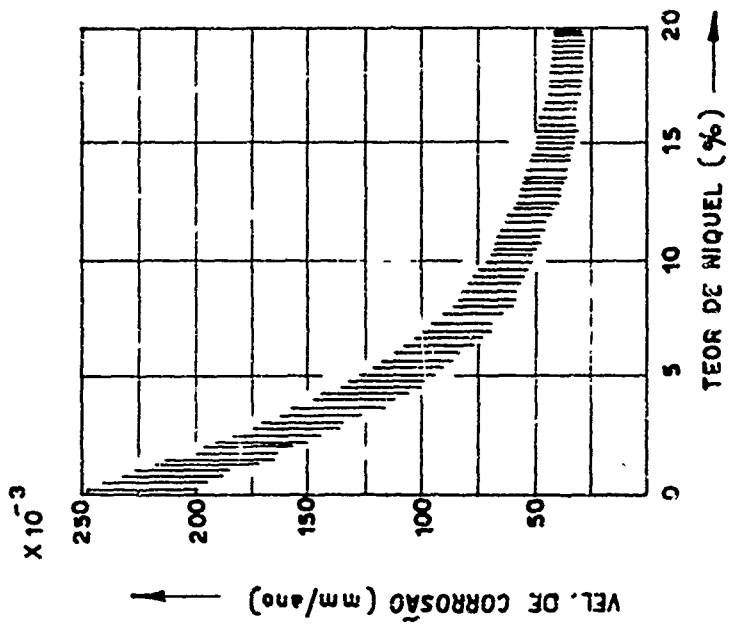

FIG. 21

Variación da resistência à corrosão de aços inoxidáveis com 15% de cromo em função do teor de níquel. A área hachureada inclui todos os valores obtidos em ensaios de 20 horas, a 30°C, realizados em água do mar saturada com oxigênio, e ativada, em uma solução de 5% de NaCl e em uma solução de 20% de CaCl<sub>2</sub> (Ref. (14), pág. 43).

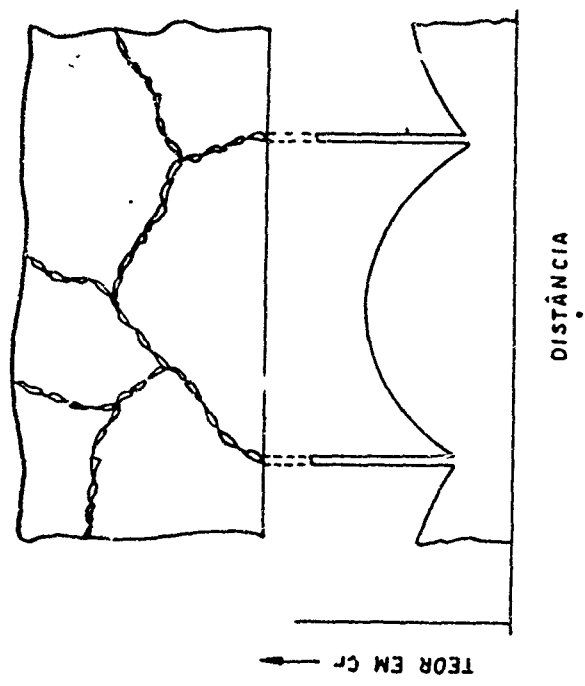

FIG. 22 Variación do teor de cromo entre o interior e o contorno dos grãos, causada pela sensibilidade.

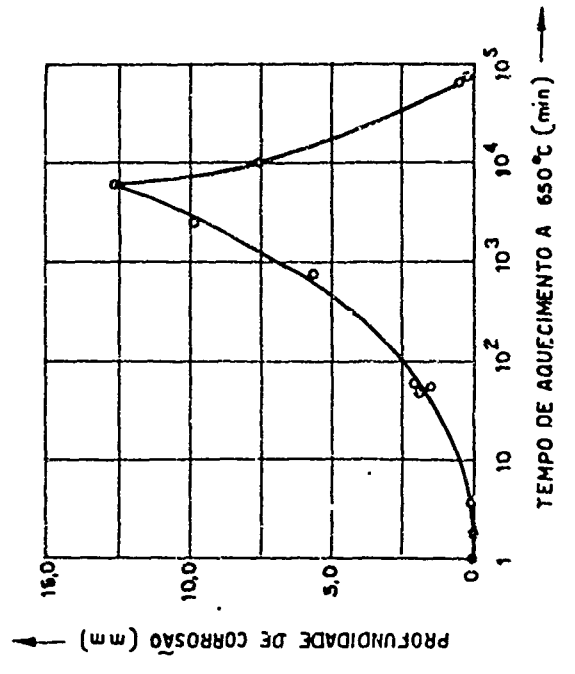

FIG. 23

Profundidade de corrosão intergranular de um aço 18/8 (contendo 0,08% de carbono e previamente solubilizado) em função do tempo de aquecimento a 650°C. A profundidade de corrosão foi medida após 100 horas de permanência em uma solução ácida de sulfato de cobre. (Ref. (20), pág. 94).



FIG. 24 Tempo necessário para sensibilização do aço inoxidável 18/8 em função da temperatura de aquecimento, e após dois diferentes tratamentos prévios: 1-aquecimento a 1100°C e resfriamento ao ar; 2-aquecimento a 1100°C e resfriamento em água. (Ref. (20), pág. 95).

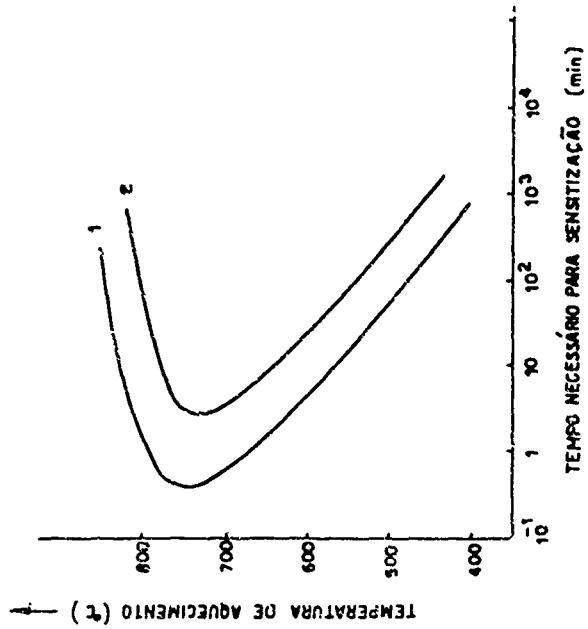

FIG. 25 Efeito de teor de carbono sobre a máxima penetração da corrosão intergranular de um aço 18/8 solubilizado após 1000 horas a 800°C e 100 horas em solução ácida de sulfato de cobre. (Ref. (20), pág. 93).

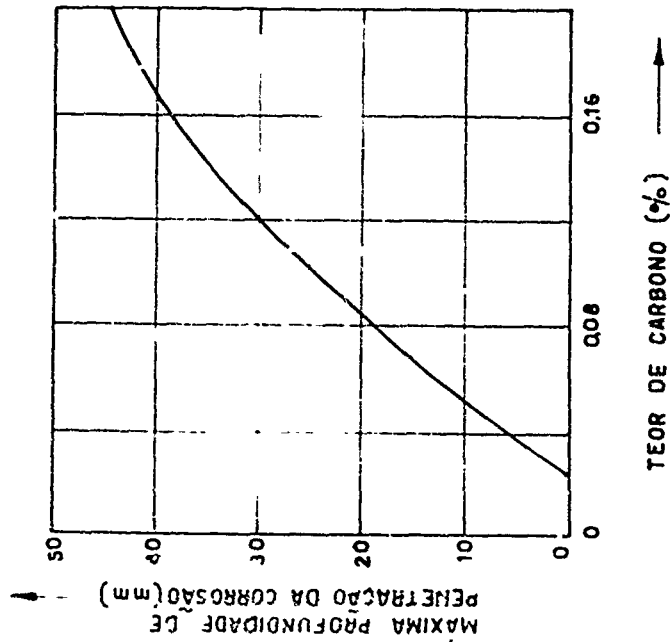

FIG. 26 Corrosão intergranular de um tubo de aço inoxidável austenítico AISI 316. Seção transversal. Sem ataque. Ampliação de 200 diâmetros.





FIG. 27 Mesmo aço da Fig. 26. Grãos de austenita e carbonetos em contornos de grão. Corrosão intergranular na parte inferior. Secção transversal. Ataque: água+régia. Ampliação de 1000 diâmetros.



FIG. 28 Aspecto do desenvolvimento da corrosão nas regiões vizinhas a uma das soldas do anel de aço inoxidável AISI 302. Secção transversal. Ataque: ácido clorídrico. Ampliação de 10 diâmetros.

FIG. 29 Corrosão intergranular do anel de aço inoxidável na região da solda. Seção transversal. Sem ataque. Ampliação de 200 diâmetros.

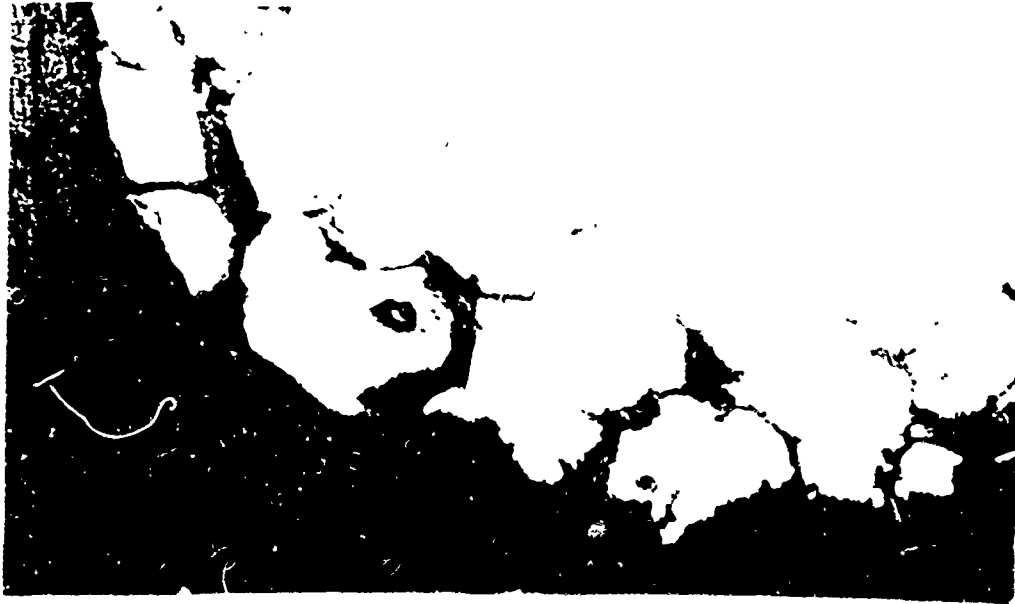

FIG. 30 Tempo decorrido antes da ruptura em função da tensão aplicada. (Ref. (24), pág.5).

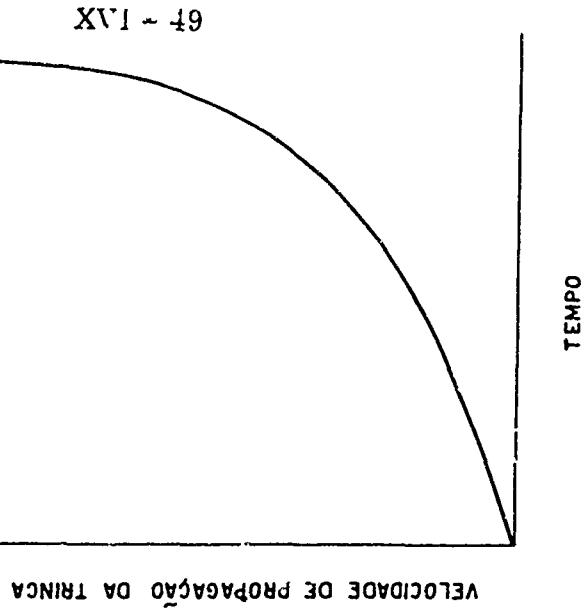
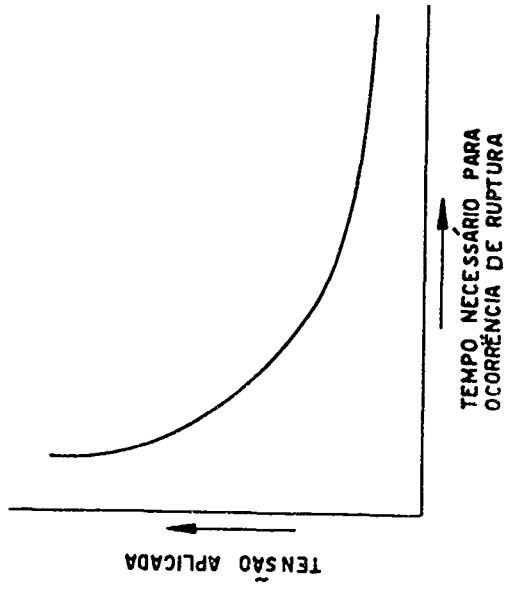

FIG. 31 Aumento da velocidade de propagação da trinca com o tempo. (Ref. (26), pág.5).



FIG. 32 Tubo com argamassa parcialmente removida, mostrando arames rompidos.

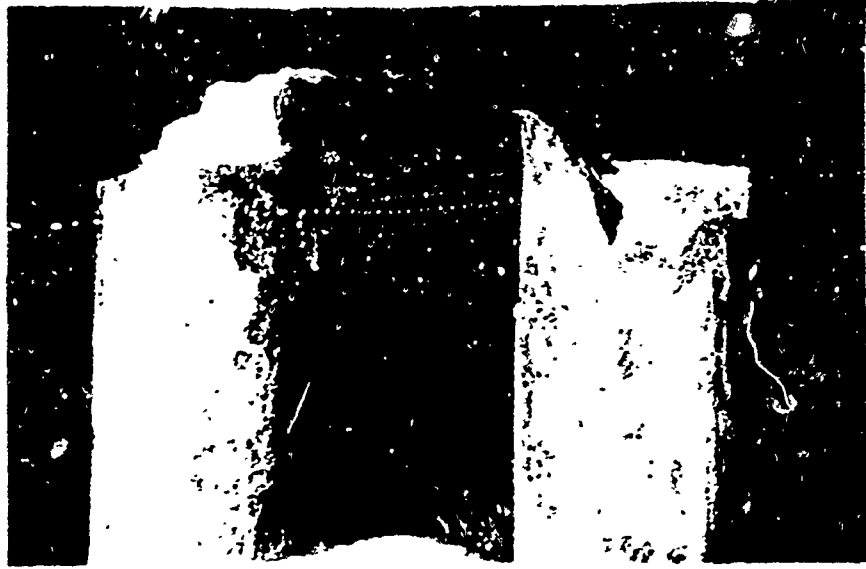

FIG. 33 Aspecto de duas fraturas frágeis observadas.

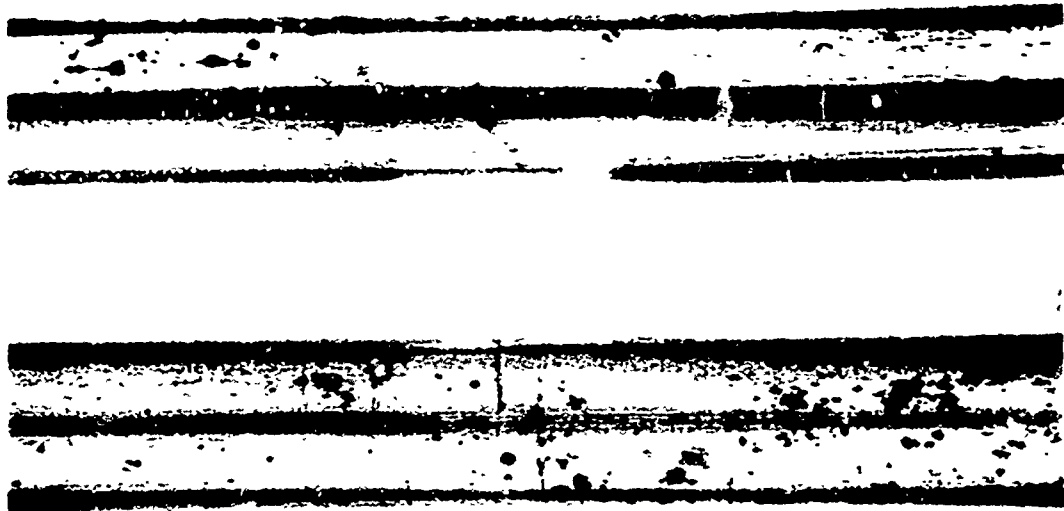

FIG. 34 Aspectos da superfície dos arames.  
Ampliação de 4 diâmetros.

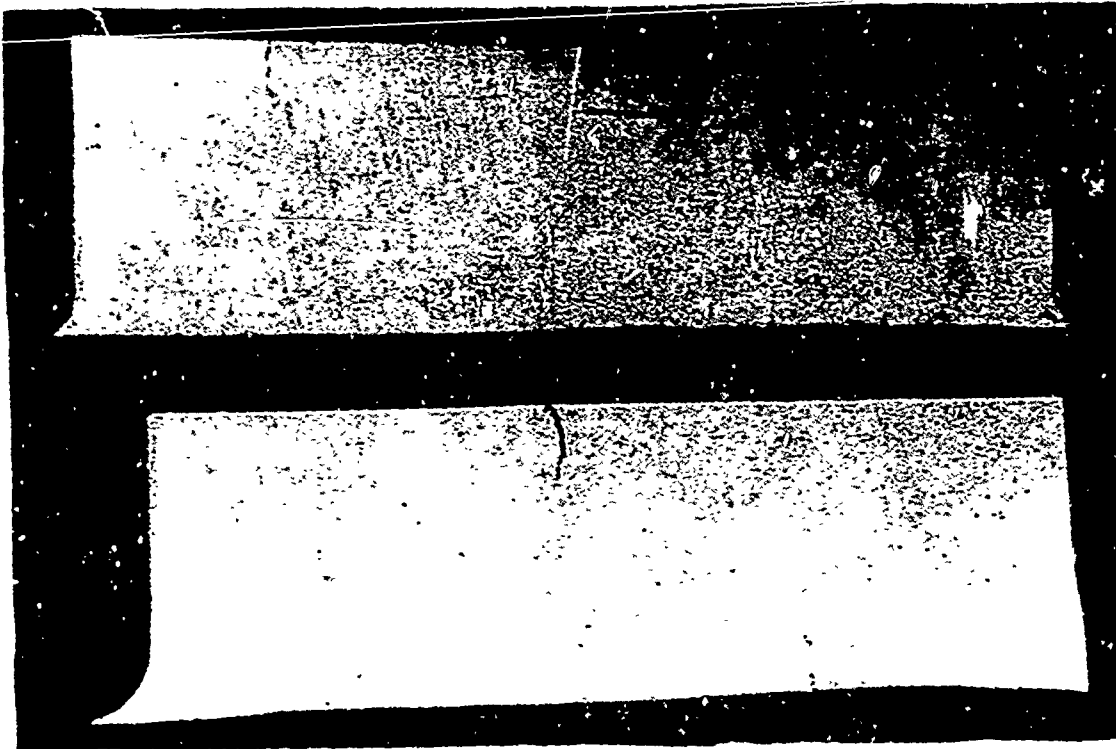

FIG. 35 Fissuras observadas na secção longitudinal. Ampliação de 7 diâmetros.

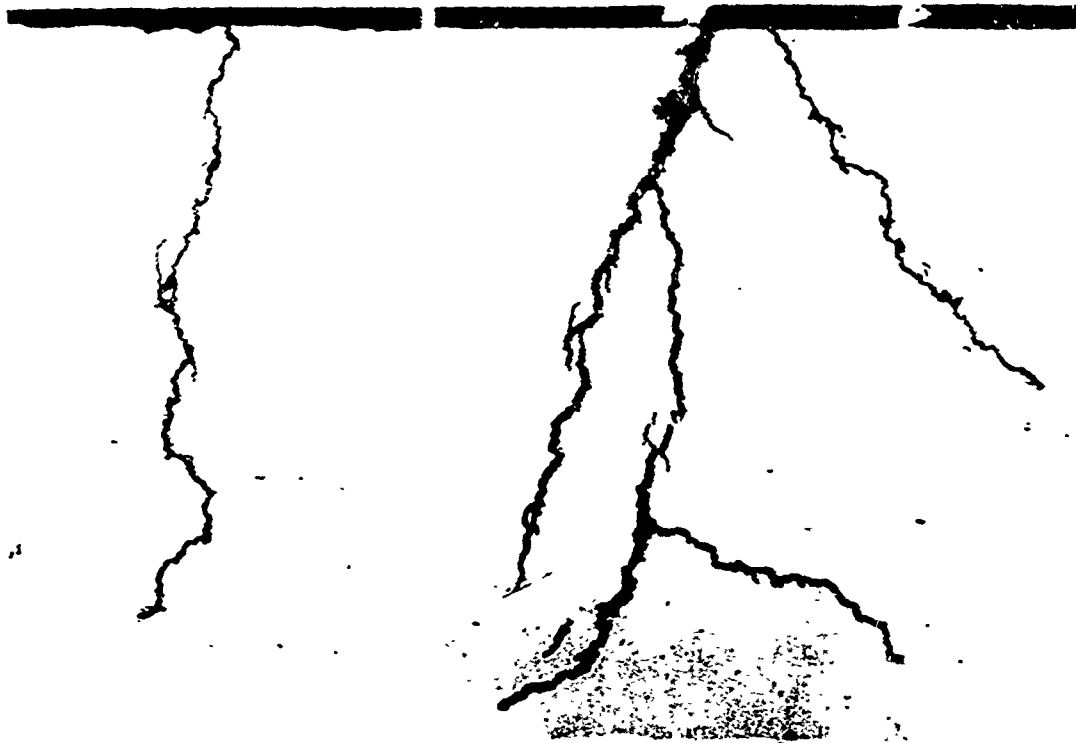

FIG. 36 Detalhes de fissuras da figura anterior. Ampliação de 80 diâmetros.

## FABRICACION DE PLACAS PORCSAS

por Luis A. Boschi

### Introducción

El objetivo del presente trabajo es la obtención de materiales filtrantes en forma de placas a partir de polvos metálicos y la medición de sus propiedades más importantes. Todo ello contemplando especialmente el problema nacional en cuanto a materias primas y equipos, con miras a ser utilizado por la industria. Se describe además una nueva atmósfera protectora de muy fácil producción.

### EQUIPO UTILIZADO

#### Prensa

Se utilizó una pequeña prensa manual capaz de dar una carga de 10 toneladas. La escala se recalibró con un dinamómetro de aro deformable asegurándose las lecturas en 3%.

#### Matricería

Se usaron dos tipos de matrices: para prensar en frío, fabricadas en acero plata, para pastillas de 20 mm de diam., y para prensar en caliente, fabricadas en acero W K Z de 10 mm de diam. Ambas con pistón superior e inferior móviles para facilitar la extracción de la muestra prensada. La matriz para prensar en caliente tiene un sistema calefactor exterior eléctrico, termostaticado con termocupla y pirómetro de corte automático, algunos detalles pueden observarse en la Figura 1.

#### Horno

Para el tratamiento térmico en atmósfera reductora, se usó un horno tubu-

lar de 4 cm de diam. y 45 cm de largo, de cuarzo, bobinado con alambre Kantal que permite llegar hasta 1300°C consumiendo una potencia de 1,2 kw. El sistema está termostatzado con pirómetro de corte automático y termocupla de cromel-alumel. La atmósfera reductora se introduce por una de las tapas de acero inoxidable y sale por la otra, la termocupla de medición y control entra a través de la primera, tapa envainada en acero inoxidable, el cierre hermético de ambas tapas se obtiene con guarniciones de amianto, el gas protector remanente es quemado a la salida, este último detalle permite un control permanente del mismo, ver Figura 2.

### Granulometría de los polvos

Se determinó con un equipo de tamices seriados vibratorios del tipo convencional.

### Dispositivo para medir el caudal del líquido que pasa a través de la pastilla porosa, en función de la presión de entrada

Fue construido con accesorios comunes de instalación de gas domiciliario, con una cupla de unión de 3/4 pulgada de diam. y dos niples de la misma rosca se armó el sistema esquematizado en la Figura 3, en el cual la pastilla porosa queda entre dos guarniciones de goma, prensada por los niples. Al niple más largo se le soldó con estaño un tubo lateral para acoplarle el manómetro de medida de la presión de entrada, por este mismo niple entra también el agua usada en la medición obtenida directamente de la red de distribución domiciliaria. Las medidas de caudal se hicieron recogiendo el agua de salida en un recipiente de volumen conocido y midiendo el tiempo con un cronómetro.

### Dispositivo para medir la carga de rotura

Se construyó en acero, sin templear y de acuerdo al diseño adjunto, Fig. 4, en el cual la pastilla queda firmemente sujeta al apretar la rosca inferior de sujeción, evitándose las pérdidas de presión mediante las guarniciones de goma. En la parte superior se coloca grasa liviana para la uniforme transmisión de la presión y además evitar, por su viscosidad, pérdidas. Para que la grasa no pase a través de la pastilla en ensayo cerramos sus poros con un disco de polietileno delgado (0,2 mm) el cual resiste muy bien la presión ejercida por la grasa pues se apoya contra la pastilla porosa sin entrar en sus poros y además al romperse ésta, no ofrece ninguna resistencia mecánica. Para realizar el ensayo todo el dispositivo es comprimido en la prensa antes citada y la carga de rotura leída en la misma, solo resta calcular el área de la pastilla en ensayo y de ahí deducir la presión específica de rotura.



TRABAJO REALIZADO

Se estudiaron tres materias primas de nuestra plaza y luego de algunos ensayos previos consistentes en: observación microscópica, determinación de granulometría y compresión en frío, se seleccionó un polvo de bronce provisto por Mercader (La Plata), que tiene las siguientes características:

Composición química:	Cobre	90%
	Estaño	8,5%
	Zinc	0,5%

Método de obtención: por pulverización en estado líquido, fundido

Observación microscópica: forma prácticamente esférica y muy regular, ver fotomicrografía No. 1.

Determinación de la granulometría y del tamaño de las partículas por medición al microscopio con micrómetro ocular:

Malla	retenido %	diám. mínimo y máximo	
50	34,4	350	500
70	26,7	250	350
100	19,6	150	250
150	13,6	80	150
200	4,3	70	80
250	0,9	45	70
325	0,23	30	45
menos 325	0,21	menos de 30	

Se hicieron ensayos de compactación en frío con muy mal resultado, las pastillas no tenían cohesión suficiente aún prensadas a 20 ton/cm<sup>2</sup> pese a ser ya muy poco porosas. Los ensayos de compactación en caliente hechos a 300°C y 500°C dieron prácticamente el mismo resultado solo a 600°C las pastillas tenían cohesión, pero su densidad aparente se había elevado a 8,5, es decir casi la del bronce, lo cual significa muy pocos poros.

De todo lo anterior se observa que el número de poros es muy pequeño y la tecnología de producción muy compleja, además el prensado en caliente acorta extraordinariamente la vida útil de las matrices. Por lo tanto se intentó usar el "fritage", es decir: la sinterización sin prensado previo, para ello se construyó

una serie de doce matrices cilíndricas con ambas caras desmontables según el diseño adjunto (Fig. 5).

El material usado fue hierro común de caño de gas, para el cuerpo y chapa de hierro para las tapas. Usamos para el tratamiento térmico el horno antes descrito y adoptamos en primera instancia el gas común de cañería domiciliaria (metano 90%, propano 10%) como atmósfera protectora, para ello conectamos directamente la entrada del horno a la red de distribución y quemamos el gas en el caño de salida con una llama luminosa de 5 a 6 cm de alto. Iniciamos la serie de ensayos a la temperatura de 700°C y una hora de tratamiento térmico, esto significa cargar las muestras en el horno frío, comenzar a circular el gas hasta desalojar todo el aire del interior del mismo, conectar la calefacción y al llegar a 700°C mantener dicha temperatura durante una hora, interrumpir la calefacción y dejar enfriar en el horno hasta temperatura ambiente siempre con circulación de gas.

Las mallas usadas en este ensayo fueron: 50, 70, 100 y 150. El resultado no fue nada satisfactorio pues si bien las muestras eran muy porosas, no tenían resistencia mecánica, se desmenuzaban al rascarlas con la uña, el efecto era muy evidente en las mallas más gruesas 50 y 70.

El ensayo siguiente, aumentado la temperatura a 800°C, prácticamente no mejoró la calidad de las pastillas. Decidimos cambiar la atmósfera por otra mucho más protectora, usamos hidrógeno puro. Se cargaron en el horno las mismas mallas anteriores, la temperatura se fijó en 700°C y el tiempo una hora.

El resultado fue una mejora notable de la superficie, la cual se presenta limpia y casi brillante de color metálico rojizo, pero las probetas no tienen suficiente cohesión, se desgranar al rascarlas. En el ensayo siguiente elevamos la temperatura a 800°C, manteniendo las otras condiciones iguales. Resultado: las pastillas se contraen fuertemente en sus moldes, aproximadamente el 15% en volumen, se redujo el número de poros, su aspecto era limpio y metálico, tenían desde luego gran resistencia mecánica.

Todo ello es prueba de excesiva temperatura, un ensayo a 750°C nos dió poca cohesión, por lo tanto decidimos acortar el tiempo, manteniendo 800°C a media hora. El resultado fué excelente: buena cohesión, poca contracción (2 a 3%), superficie limpia y pulida. En un intento de bajar el costo y los riesgos del proceso cuando se usa hidrógeno, se nos ocurrió probar una atmósfera muy reductora formada por burbujeo de gas natural en alcohol metílico, se pueden ver detalles de la instalación en el diagrama adjunto (Fig. 2).

Repetimos las condiciones anteriores: cargamos las mallas 50, 70, 100 y 150, la temperatura fué de 800°C y el tiempo fué de media hora, usando la nueva atmósfera. Resultado: realmente extraordinario, con mejoramiento del brillo superficial. La idea ha sido objeto de una patente nacional tramitada con el número 183.356 el 28 de Agosto de 1963. Con este ensayo dimos por terminada la producción de pastillas y comenzamos a medir sus propiedades.

DETERMINACION DEL CAUDAL EN FUNCION DE LA PRESION

Con el dispositivo descrito anteriormente se midió, usando agua, el caudal que pasa a través de los filtros en función de la presión de entrada, la presión de salida es la atmosférica. Es decir, manteniendo la presión de entrada constante se midieron los segundos que tarda en pasar un determinado volumen, eso a varias presiones de entrada y para cada filtro, tipificado por su malla. Los resultados de dichas mediciones se presentan en la Figura 6.

MEDICION DE LA PRESION DE ROTURA

Usando la técnica y el aparato antes descrito se realizaron una serie de ensayos hasta rotura, tres por cada filtro, correspondiente a cada malla. Con esos datos se calculó por unidad de área filtrante y por milímetro de espesor la resistencia específica para cada malla:

Malla	presión de rotura por cm <sup>2</sup> y por mm. de espesor
50	60 atmósferas
70	70 "
100	85 "
150	88 "

OBSERVACION MICROSCOPICA

Se utilizó un microscopio metalográfico Leitz para fotomicrografía modelo Panphot, con accesorios para macrografía. Las placas eran de vidrio 9 x 12, procedencia nacional, marca Lasaf y tipo normal. Se comenzó por obtener fotomicrografías del polvo sin sinterizar, pero después de haber sido tamizado se tomaron las mallas extremas 50 y 150 y se procesaron juntas en la misma copia (Fig. 7).

Podemos observar con toda claridad el aspecto uniforme de cada partícula. La fotomicrografía de la Fig. 8 muestra las probetas tratadas a 800°C durante una hora, es decir un tratamiento excesivo; dichas probetas habían disminuido su volumen aproximadamente el 15% y con ello el número de poros.

Estas pastillas antes de ser observadas fueron pulidas con papeles esmeril de grano 100, 180, 400 y 600, y luego atacadas con ácido nítrico al 50%. Como ve

mos en la fotografía las partículas han dejado de ser esféricas para tomar formas poliédricas preferentemente de corte exagonal, tendiendo así a ocupar todo el espacio y eliminar los huecos y poros. La foto de la Figura 9 corresponde a una de las mejores muestras obtenidas a 800°C, media hora y atmósfera gas-metanol. La probeta fué atacada y pulida igual que las anteriores. En ella se vé con toda claridad el proceso de sinterizado en el cuello de contacto de los granos, donde desaparece toda discontinuidad quedando las esferas metálicas soldadas, por difusión entre sí, dejando a sus lados poros de forma aproximadamente tetraédrica, cuyo corte da los triángulos negros de la foto.

La fotomicrografía de la Fig. 10 corresponde a dos filtros terminados, aumentados 6 veces correspondientes a las mallas 50 y 150.

### CONCLUSIONES

Primera: Para la obtención de filtros de buenas propiedades debe partirse de polvos esferoidales como los obtenidos por soplado en estado líquido.

Segunda: No es necesaria ninguna presión de compactación ni en frío ni en caliente. Esto hace al proceso de muy bajo costo, pues solamente deben construirse matrices de chapa de hierro con la forma del filtro a obtener. La vida de las matrices es muy larga, pues no están sometidas a ningún esfuerzo mecánico ni ataque térmico u oxidación al ser calentadas en atmósfera protectora.

Tercera: La atmósfera protectora es muy simple, solo gas de la red de distribución domiciliaria añadido de metanol por burbujeo. Patente Argentina en trámite No. 183.356.

Cuarta: La capacidad filtrante es muy buena, para un filtro obtenido con polvo malla 50 (350 a 500 micrones) que retiene partículas de 40 micrones es capaz de filtrar un litro por minuto y por cm<sup>2</sup> con una presión de entrada de solamente 0,5 atmósfera.

Quinta: Muy buena resistencia mecánica, el mismo filtro citado en la conclusión anterior es capaz de soportar una presión máxima de 300 atmósferas siendo su espesor de 5 mm y su diámetro de 20 mm.

Sexta: Además el filtro metálico posee las siguientes características: a) buena resistencia a la corrosión; b) resistencia a temperaturas elevadas, se pueden filtrar líquidos muy calientes; c) no son absorbentes; d) son de fácil limpieza (a contracorriente); e) se pueden fabricar con una gran uniformidad y en formas muy variadas y complejas; f) pueden ser mecanizados y soldados.

AGRADECIMIENTO

Mi sincero reconocimiento al Dr. Alberto Zanetta por haber orientado este trabajo, al Prof. J. A. Sabato por haberme facilitado las condiciones para la realización del mismo, al Dr. Antonio Carrea por sus útiles sugerencias y apoyo, y por último a los señores Riva y Baroni por la entusiasta colaboración prestada durante su desarrollo.

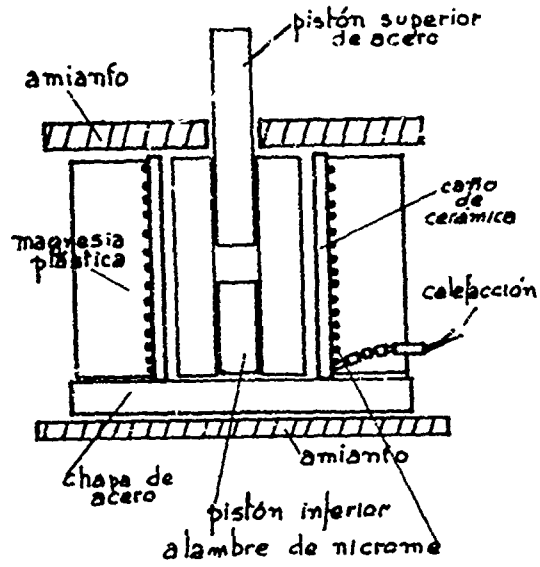

Fig. 1 Horno y Matriz de Sinterizado en Caliente

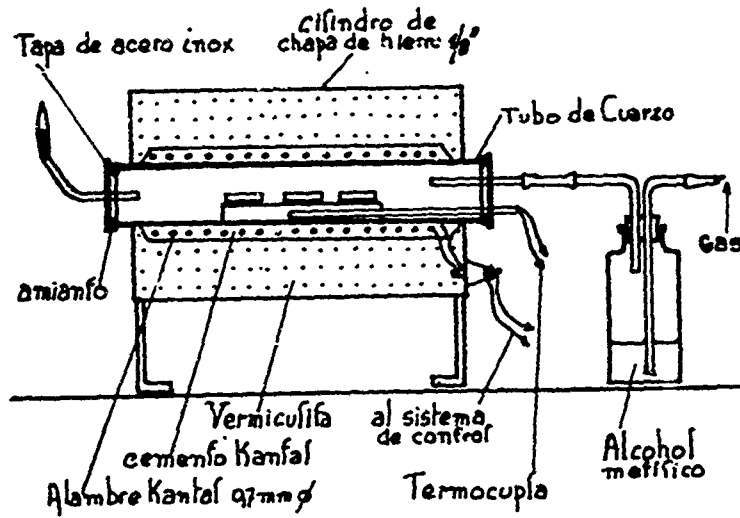

Fig. 2 Horno de Atmósfera Controlada

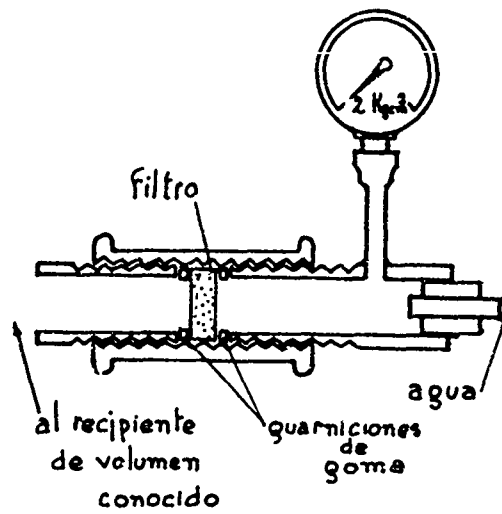

Fig. 3 Medidor del Caudal de Salida en Función de la Presión de Entrada

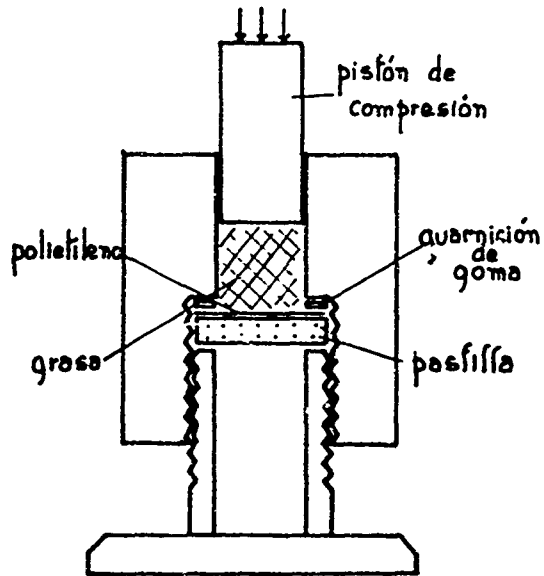

Fig. 4 Dispositivo de Medida de la Presión de Rotura

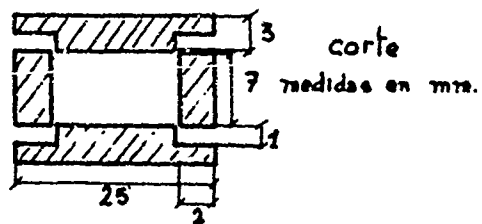

Fig. 5 Matriz para Sinterizado sin Compresión, sólo Calefacción

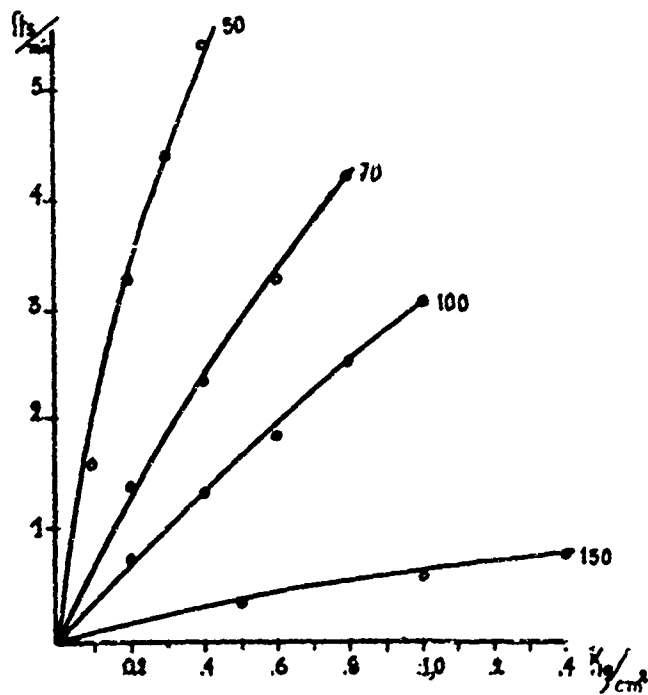

Fig. 6 Caudal de Salida en Función de la Presión de Entrada





Figura 7 Determinación de Forma de Grano y Comparación de Polvo de Bronce



Figura 8 Determinación de Granos y Sinterizado en Filtros

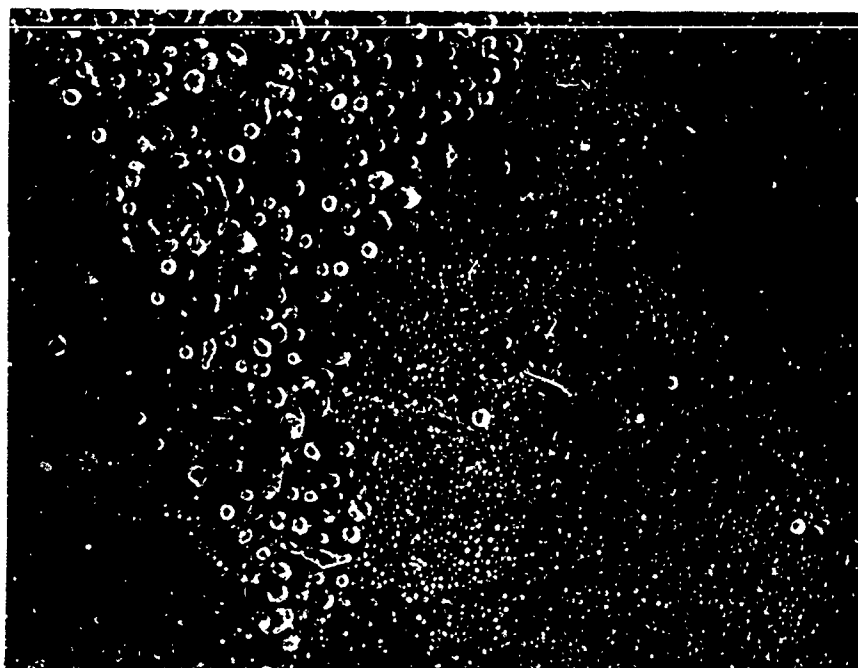

Figura 9 Determinación de Granos y Sinterizado en Filtros

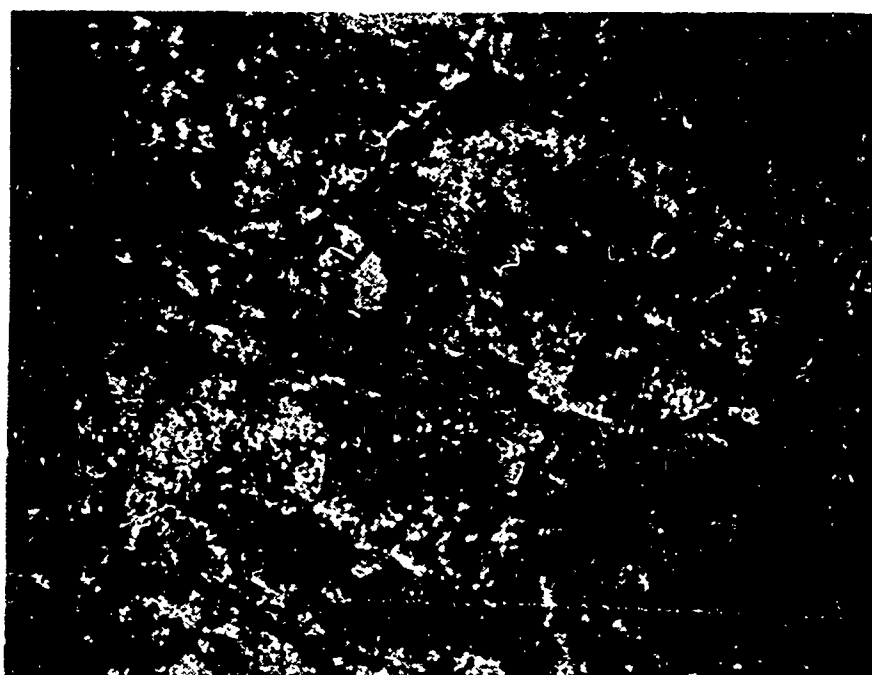

Figura 10 Determinación de Granos y Sinterizado en Filtros

NUEVA TEORIA PARA EL CALCULO DE ESFUERZOS  
EN LOS TRATAMIENTOS MECANICOS

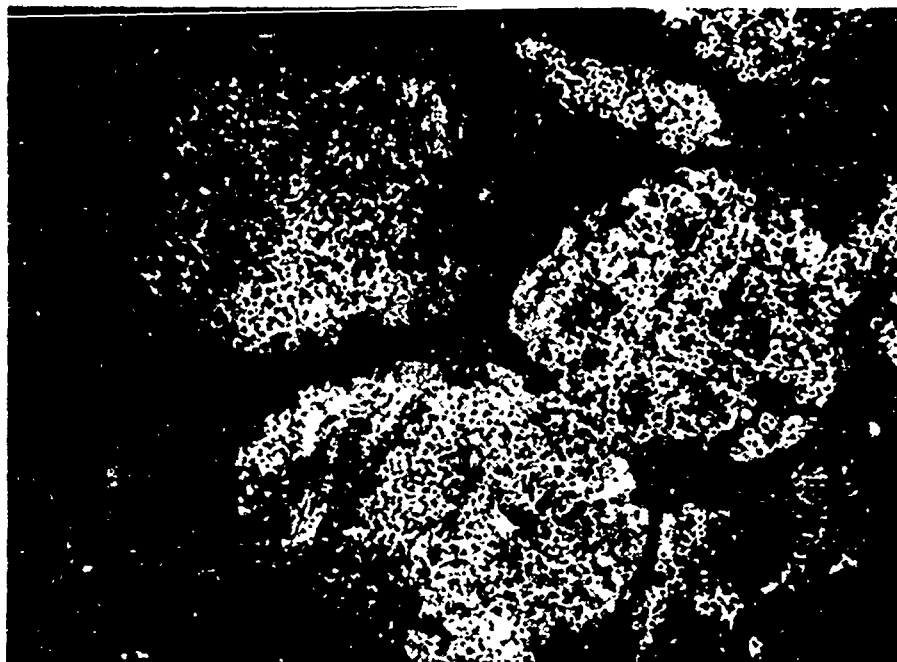
por Eduardo R. Abril

Introducción

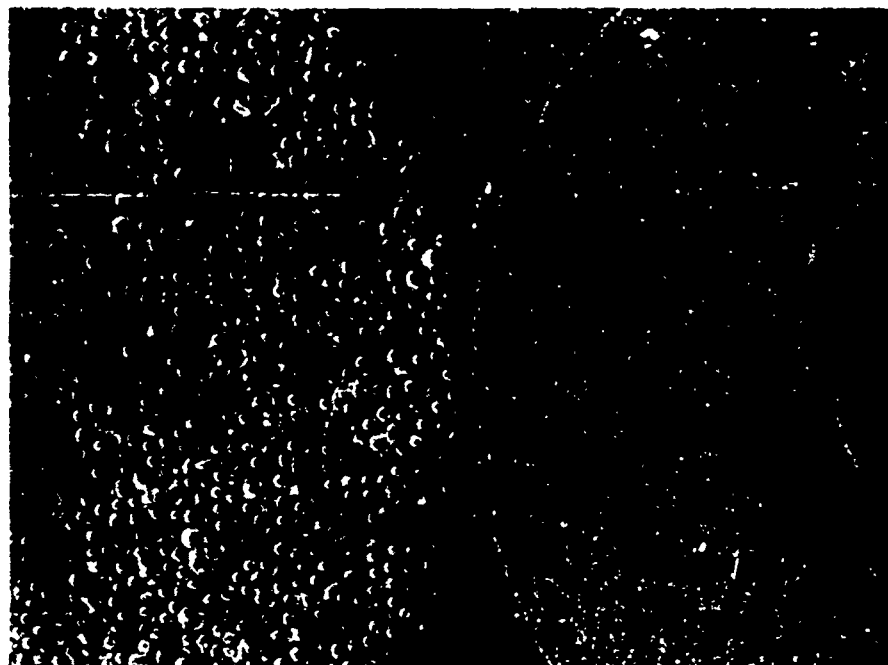
La aplicación de principios termodinámicos ha permitido, en muchos casos, resolver en forma clara y sencilla problemas tecnológicos cuya solución por otros medios era sumamente compleja.

Se considera que, siempre que sea posible aplicar criterios termodinámicos, las conclusiones a que se arribe serán rigurosamente ciertas, si las hipótesis iniciales lo son.

Independientemente de las objeciones de carácter lógico que pueda tener la aplicación en la solución de problemas prácticos, de leyes generales aceptadas "a priori", como lo son las termodinámicas, la verdad es que los resultados obtenidos hasta hoy dan a esas leyes una fuerza de convicción indiscutible en los campos en que han sido aplicadas.

Una de las ventajas innegables del método termodinámico es que permite prescindir de los detalles característicos de las transformaciones de los sistemas, y obtener conclusiones vinculadas exclusivamente con los estados inicial y final de dichos sistemas.

Este es el criterio que se utiliza en el presente trabajo, donde se encara la solución del problema de la determinación de potencias y esfuerzos en los procesos tecnológicos de deformación plástica, y por ello es posible decir que se ha aplicado un criterio termodinámico.

LA ENERGIA EN LOS SISTEMAS MECANICOS

Toda vez que se aplica un esfuerzo a un cuerpo sólido, se producen defor-

maciones en el mismo. Como consecuencia de ello, el cuerpo absorbe una cierta cantidad de energía que podrá quedar almacenada en el mismo o ser devuelta principalmente en forma de calor.

Cuando los esfuerzos aplicados son bastante elevados y los materiales tienen capacidad de deformación plástica, como sucede en los procesos que aquí se analizan, los cuerpos cambian de forma, y la cantidad de energía que el cuerpo retiene es sumamente pequeña en comparación con la que ha sido necesaria aplicar (aproximadamente el 10%).

El cambio de forma por deformación plástica es, pues, un problema de muy poco rendimiento termodinámico. A ello debe agregarse el hecho de que, para producir el cambio de forma es generalmente necesario consumir una gran cantidad de energía destinada a vencer los frotamientos que se originan por contacto entre el material y los dispositivos usados en la transformación.

La energía requerida por un proceso de deformación plástica, mediante el cual un cuerpo pasa de un estado a otro, puede calcularse si se conoce la variación, durante el proceso, de las tensiones existentes en cada punto del material, y además la ley que vincula dichas tensiones con las deformaciones unitarias que las acompañan.

En el estado actual, ese conocimiento es muy relativo y prácticamente desconocido en ciertos procesos, como el de estirado de alambres en hileras.

En vez de analizar la variación de tensiones y deformaciones que se producen durante el proceso, tal como se hace en la teoría clásica, se propone aquí la hipótesis de que la energía requerida para el cambio de forma por deformación plástica depende de los estados iniciales y finales del cuerpo, y no del modo en que se ha producido la deformación, siempre que en el proceso no se originen trabajos redundantes.

Aceptado este principio, y aclarado el concepto de trabajo redundante, es posible determinar, sobre nuevas bases, fórmulas para calcular la energía y los esfuerzos requeridos en procesos tecnológicos.

Antes de hablar del trabajo redundante y prescindiendo del mismo, se analizarán las razones que abonan la hipótesis de que el trabajo requerido para un cambio de forma es independiente del método usado para producir dicho cambio.

La principal razón es la idea de que la naturaleza trata siempre de ahorrar energía en sus transformaciones. Si un cambio de forma puede ser logrado de dos modos distintos, ambos continuos y progresivos, parece lógico que la naturaleza no tuviera interés en gastar más energía en un caso que en el otro, si los estados finales, en forma y propiedades, son iguales.

Como se observa que, a igualdad de temperatura, las propiedades físicas y

químicas de los materiales metálicos al final de los procesos tecnológicos dependen prácticamente del cambio de dimensiones (grado de reducción) y no de la manera en que dicho cambio se ha logrado, resulta lógico suponer que la energía absorbida por el cuerpo en ambos casos sea la misma. También resulta bastante lógico admitir, siempre prescindiendo del trabajo redundante, que la energía cedida en forma de calor al ambiente y por ende la energía total requerida sea la misma en ambos casos.

### TRABAJO REDUNDANTE

El cambio experimentado por un cuerpo al pasar de un estado A a un estado B, de mayor nivel energético, exige siempre una energía mayor que la diferencia entre las energías que contiene el cuerpo en ambos estados.

Se supone en este estudio que existe un mínimo de energía adicional para que un material dado pueda pasar, por deformación plástica, de un estado de forma A a un estado de forma B, en igualdad de condiciones de temperatura y velocidad de deformación.

Sumando esa energía mínima adicional y la energía retenida en el cuerpo como consecuencia de la deformación, que se supone constante para un cambio de forma dado, se obtendrá lo que se designa como energía requerida para el cambio de forma. Si la energía utilizada en un proceso tecnológico es mayor que la requerida para el cambio de forma, se dice que el exceso corresponde a un trabajo redundante recibido por el cuerpo.

Un ejemplo aclarará este concepto de trabajo redundante. Si el cilindro de forma A de la Fig. 1 recibe un trabajo mecánico T para ser llevado a la forma B y otro trabajo igual para restituirlo a sus dimensiones iniciales como se muestra en C, diremos que el cuerpo ha recibido un trabajo redundante igual a 2T. Si el proceso continuara hasta que el cuerpo alcance la forma D, empleándose para ello un trabajo adicional T', la energía total recibida por el cuerpo en el proceso sería:

$$E = 2T + T'$$

El primer término del segundo miembro de esta expresión será considerado trabajo redundante en relación al proceso de pasar de A a D.

Se origina trabajo redundante siempre que exista fricción, y también cuando cambia el sentido de las fuerzas aplicadas, como sucede en muchas operaciones de forja.

Dado que en el ejemplo anterior el cambio de propiedades, y por consi-

guiente, de energía retenida, en los estados A y C puede llegar a tener cierta importancia, es lógico admitir que no todo el trabajo redundante es trabajo perdido con respecto a los estados iniciales y finales de un proceso, pero recordando que el trabajo retenido en los procesos tecnológicos es del orden del 10% del empleado, esas diferencias pueden considerarse despreciables y decir que el trabajo redundante se pierde siempre totalmente en forma de calor.

### EL TRABAJO REDUNDANTE EN LA FRICCIÓN

Consideremos el caso de estirado de un alambre a través de una hilera cónica. Si la superficie de ésta es teóricamente perfecta, no existirá frotamiento entre el material del alambre y el de la hilera, y el proceso de transformación será continuo y homogéneo mediante la progresiva disminución de área de cada sección transversal del alambre.

Por el contrario, si las superficies presentan rugosidades, cada sección transversal del alambre sufrirá variaciones no continuas de área. En efecto, dichas secciones en vez de disminuir progresivamente desde su entrada en la hilera hasta su salida, sufrirán, como consecuencia de las rugosidades de la hilera, aumentos parciales de área, tal como lo muestra exageradamente la Fig. 2.

En dicho ejemplo, el diámetro  $D_0$  de un segmento de volumen  $\Delta V$  disminuirá en forma continua hasta  $D'$ . En ese momento su valor como consecuencia de la rugosidad de la hilera, aumentará hasta  $D''$  para disminuir luego el valor  $D'$  antes de continuar el proceso.

Cada vez que se produce, como consecuencia de la rugosidad de las paredes de la hilera, un paso tal como el de  $D' - D'' - D'$ , se efectúa un trabajo redundante  $2T$ , siendo  $T$  el trabajo relacionado con el paso de  $D'$  a  $D''$  e igualmente el requerido para volver de  $D''$  a  $D'$ .

### ENERGÍA REQUERIDA PARA EL CAMBIO DE FORMA EN EL ESTIRADO DE ALAMBRES EN HILERAS

Si bien la teoría que se desarrolla en este trabajo es aplicable a cualquier proceso tecnológico de deformación plástica, a continuación se tratará solamente el problema del estirado de alambres o barras en hileras ("trefilación"), dejando para otra oportunidad la aplicación de los principios enunciados a otros procesos.

Si se plantea el problema de transformar por deformación plástica un cilindro metálico de sección  $A_0$  y longitud  $L_0$  en otro de sección  $A_1$  y longitud  $L_1$ , se admite en general que el volumen se mantendrá inalterable, es decir:

$$V = A_0 L_0 = A_1 L_1 \quad (1)$$

De acuerdo con la hipótesis, antes establecida, de que la energía necesaria para el cambio de forma depende sólo de los estados iniciales y finales, podremos calcular cual es el valor de esa energía suponiendo que hemos pasado del estado inicial al estado final, estirando el cilindro mediante un ensayo de tracción. El diagrama obtenido en dicho ensayo nos permitirá calcular el valor de la energía empleada en el proceso. Ese valor podrá luego utilizarse en relación a cualquier otro modo de producir el mismo cambio de forma.

El hecho de que, en un ensayo de tracción, los materiales metálicos de gran plasticidad sufran un fenómeno de inestabilidad llamado estricción, impide obtener reducciones de sección uniformes del orden de las obtenidas en los procesos tecnológicos. Sin embargo, ello no es un inconveniente para que podamos determinar con bastante exactitud el aspecto que presentaría el diagrama de tracción, si la estricción pudiera ser evitada y la sección transversal llevada al valor mínimo correspondiente al momento de la rotura en la zona de estricción (\*).

La fig. 3 muestra un diagrama típico convencional de tracción y el aspecto que el mismo presentaría si la estricción pudiera ser evitada hasta el momento de la rotura.

Suponiendo que el ensayo se suspendiera cuando el cilindro de longitud  $L_0$  alcance la longitud  $L_1$ , la distancia  $L_1 - L_0$  determinará el alargamiento experimentado hasta ese momento, y la energía consumida en el cambio de forma será la correspondiente a la superficie del diagrama hasta la línea BC.

Si produjéramos el estiramiento del cilindro de longitud  $L_0$  hasta el valor  $L_1$  de otro modo, y también sin trabajo redundante, la energía absorbida sería la misma que la anterior, de acuerdo a lo ya expresado. El valor de esta energía puede ser calculado con bastante exactitud si se la asimila a la superficie del rectángulo OABC (\*\*).

Dicha superficie W es igual a:

$$W = P_m (L_1 - L_0)$$

(\*) Mediante ensayos de tracción en un medio bajo presión hidrostática puede ser evitada la estricción. También es posible imaginar un ensayo discontinuo en el que la probeta se vaya tomando cada vez en la zona estriccionada, para lograr una deformación prácticamente uniforme.

(\*\*) Si se requiriese mayor exactitud, dicha superficie puede ser afectada de un coeficiente que resultará siempre muy próximo a la unidad, debido al gran valor de la deformación de rotura al eliminarse la estricción.

donde  $P_m$  es la carga máxima alcanzada en el ensayo. Como, por definición, la resistencia a la tracción de un material es igual a la carga máxima sobre la sección inicial, el valor de  $W$  puede expresarse así:

$$W = \sigma_0 A_0 (L_1 - L_0) \quad (2)$$

donde  $\sigma_0$  es la resistencia a la tracción del material "antes de ser sometido al estiramiento".

Si quisiéramos conocer el valor de la energía requerida para producir el cambio de la forma del cilindro desde  $A_0 L_0$  hasta  $A_1 L_1$  (sin frotamientos ni otros trabajos redundantes), por un proceso tecnológico tal como el de estirado en hileras, bastaría, pues, conocer el valor de la resistencia a la tracción del material y los cambios de forma experimentados en el proceso. Esto permite encarar el problema en forma más simple que la utilizada corrientemente.

#### CALCULO DE LA FUERZA TEORICA EN EL PROCESO DE ESTIRADO

En el proceso de estirado en hileras interesa, más que la potencia, la fuerza que es necesario aplicar para producir el estiramiento.

Es posible, de acuerdo con lo anterior, calcular fácilmente (siempre prescindiendo de los frotamientos) el valor de esa fuerza que llamaremos  $P_0$ .

Teniendo en cuenta que la energía  $W$  será igual a  $P_0 L_1$ , podemos reemplazar en (2) y, realizando algunas transformaciones matemáticas basadas en la igualdad (1), llegar a la sencilla expresión:

$$P_0 = \sigma_0 (A_0 - A_1) \quad (3)$$

En el punto Verificaciones Experimentales se menciona una verificación experimental indirecta de esta fórmula.

#### LA FRICCION EN EL PROCESO DE ESTIRADO

Las fórmulas actualmente en uso para calcular el valor de  $P_0$  en el estirado en hileras, dan valores que en general no difieren mucho de los correspondientes a la fórmula (3), tratándose de reducciones corrientemente empleadas en la práctica.



Admitida una fórmula cualquiera para el valor  $P_0$  es posible calcular el valor  $P$  de la fuerza total (incluidos los frotamientos), si se adopta un valor determinado para el coeficiente de fricción  $\mu$ . Así, utilizando la fórmula (3), dicho valor resulta:

$$P = \sigma_0 (A_0 - A_1) (1 + \mu \operatorname{ctg} \alpha) \quad (4)$$

donde  $\alpha$  es el semiángulo de la hilera.

La gran cantidad de experiencias realizadas para verificar las fórmulas de cálculo de  $P$  llevan necesariamente a la conclusión de que, independientemente de los errores que puedan existir en la determinación de  $P_0$ , la influencia de la fricción en el proceso no puede ser la que establece la teoría clásica de la fricción, ya que las discrepancias encontradas entre la teoría y la práctica no pueden explicarse simplemente en función del error que pueda existir en el cálculo de  $P_0$ . Todo sucede como si el valor  $\mu$  variase grandemente en función de la geometría de la hilera, y no solamente de la rugosidad de las paredes de la misma y la influencia del lubricante.

Se ha intentado dar al fenómeno de fricción, interpretaciones distintas a la clásica, con el fin de lograr una mejor concordancia con los valores experimentales, y en general se acepta que la teoría clásica de fricción no puede aplicarse sin correcciones al proceso de estirado en hileras.

Veiler y Lihtman (3) encaran el problema asimilando el coeficiente de fricción a una tensión de corte. Ello parece aplicable en los casos en que se utilizan lubricantes sólidos, pero inadecuado en otros casos.

La teoría que aquí se presenta, establece que la fricción absorbe energía solamente en función del trabajo redundante asociado al fenómeno, y que ese trabajo redundante depende de los cambios de forma que experimenta el material como consecuencia de la rugosidad de las superficies contra las cuales se produce el fenómeno de fricción.

Lo explicado en relación a la fig. 2 aclara esta interpretación del fenómeno de fricción. Se supone que si la hilera tuviera una rugosidad cero (imposible de alcanzar), el valor de  $P$  en la "trefilación" sería igual a  $P_0$ . La rugosidad de las paredes introduce un trabajo redundante que dependerá del grado de rugosidad de la superficie y de la efectividad del lubricante.

La acción del lubricante debe entenderse del modo siguiente: no existiendo lubricante, la barra al atravesar la hilera llenará íntegramente todas las rugosidades de ésta produciendo aumentos y disminuciones de sección (a las que se asocia el trabajo redundante); existiendo lubricante, éste se alojará parcialmente en las rugosidades, e impedirá el "llenado" total de las mismas por el metal, por lo cual el trabajo redundante disminuirá. El lubricante no puede escapar, a pesar de las grandes presiones ejercidas sobre él, debido al "sellado" que origina el metal en los bordes de las depresiones (8).

En el caso de lubricantes sólidos la acción es equivalente, pero una energía adicional es requerida para vencer las tensiones de corte del material que sirve de lubricante. En este caso P puede disminuir por ser más efectivo el "llenado" de las rugosidades de la hilera, pero aumentar por el esfuerzo requerido en la deformación tangencial del lubricante.

### CALCULO DEL ESFUERZO PARA VENCER LA FRICCION

Aceptado el criterio anterior respecto al fenómeno de fricción durante el estirado de alambre en hileras, es posible calcular el valor del incremento de es fuerza requerido en el proceso, considerando que este incremento de esfuerzo corresponde a un trabajo redundante necesario para "llenar" las rugosidades y volver el material a las dimensiones que tendría si la hilera estuviera exenta totalmente de rugosidad.

A los fines de fijar conceptos, supongamos que fuese posible hacer que la hilera, en un momento determinado del proceso, elimine todas sus rugosidades, adquiriendo una superficie teóricamente lisa. Para ello deberíamos suponer una hilera hipotética con segmentos deslizantes sobre los que fuerzas  $F_1$ ,  $F_2$ , etc., permitieran a voluntad crear o eliminar rugosidades (ver fig. 2). Partiendo de un estado dado de rugosidad, el tronco de cono alojado en la hilera habrá recibido un trabajo redundante T necesario para llenar las rugosidades; ahora bien, si incrementamos luego las fuerzas  $F_1$ ,  $F_2$ , etc., hasta establecer el perfil teórico de la hilera, dichas fuerzas realizarán un trabajo que con gran aproximación podemos suponer igual a T.

El trabajo redundante asociado al material alojado en el tronco de cono será, pues, igual a  $2T$  y dependerá de la profundidad media de las depresiones inicialmente existentes en la hilera.

Este trabajo adicional se realiza en la práctica incrementando el valor de la fuerza teórica con un valor  $\Delta P$  que se admite como constante durante todo el proceso. Se tendrá entonces:

$$2T = d \cdot \Delta P$$

donde d será la distancia recorrida por  $\Delta P$  para ejecutar el trabajo  $2T$  asociado al material contenido en el tronco de cono de la hilera.

El valor d será la longitud correspondiente a un cilindro de sección  $A_1$  y volumen  $V_c$  igual al del tronco de cono de la hilera, es decir:

$$d = \frac{V_c}{A_1}$$

de donde resulta:

$$2T = \frac{\Delta P V_c}{A_1}$$

o sea:

$$\Delta P = \frac{2 T A_1}{V_c} \quad (5)$$

### TRABAJO REDUNDANTE ADICIONAL EN EL ESTIRADO DE ALAMBRES

Aparte del trabajo redundante asociado a la fricción, existe, durante el estirado de alambres, otro trabajo redundante debido a un abultamiento del material que se produce a la entrada de la matriz, tal como lo indica la fig. 4.

Este trabajo puede llegar a ser muy importante y en algunos casos superar el correspondiente a la fricción.

Si bien los factores que afectan a uno y otro tipo de trabajo redundante son distintos, la rugosidad de las paredes de la hilera afecta a ambos por lo que, con el fin de desarrollar una fórmula de fácil aplicación, se hará una hipótesis simplificada que permita analizar en conjunto ambos trabajos redundantes.

Si llamamos  $T'$  al trabajo redundante necesario para que el volumen  $V_c$  sufra el proceso de abultarse antes de entrar a la hilera y tenemos en cuenta que hace falta otro trabajo igual para eliminar dicho abultamiento, el trabajo redundante total (incluido el de fricción) será  $2T + 2T'$  y la fórmula (5) se transformaría en:

$$\Delta P = \frac{2 (T + T') A_1}{V_c} \quad (6)$$

### CALCULO DEL ESFUERZO DEBIDO AL TRABAJO REDUNDANTE

El valor  $T + T'$  de la fórmula (6) puede calcularse, y hallar así el valor  $\Delta P$ , con las siguientes consideraciones simplificativas:

1. El trabajo redundante puede asimilarse al necesario para incrementar en una cantidad  $e$  los radios de las secciones transversales del material contenido en un momento determinado del proceso en el tronco de cono teórico de la hilera, y para volver después los radios a sus medidas iniciales.
2. El tronco de cono de la hilera puede ser asimilado a un cilindro del diámetro igual al diámetro medio de aquél.
3. El trabajo redundante total puede considerarse aplicado intermitentemente a volúmenes iguales a  $V_c$ .

El valor  $e$ , que debe adoptarse en el cálculo, será mucho mayor que la rugosidad media de la hilera, pues, por una parte, el abultamiento a la entrada de la hilera es de un orden muy superior a dicha rugosidad media, y por otra la acción del abultamiento y de la rugosidad se manifiesta en forma progresiva, y no intermitente. El carácter progresivo del proceso hace sufrir a cada volumen elemental  $V$ , una serie de variaciones de sección motivadas por las rugosidades, contrariamente a lo que sucede en el supuesto movimiento intermitente.

Con las consideraciones anteriores pasamos a determinar el valor  $T + T'$ .

Este trabajo redundante será considerado igual al necesario para que el material contenido en el tronco de cono de dimensiones teóricas tome las dimensiones de otro tronco de cono de igual volumen, pero con los radios de sus secciones transversales incrementados en la magnitud, o bien, lo que se supone equivalente para que el proceso se realice en sentido inverso (\*).

Considerando cilindros de igual volumen y altura que los troncos de cono mencionados, con secciones transversales  $A_m$  y  $A'_m$  (según correspondan al tronco de cono primitivo o al incremento), las áreas de estas secciones corresponderán respectivamente a las áreas de las secciones medias de ambos troncos de cono.

Si llamamos respectivamente  $h$  y  $h'$  a las alturas de los cilindros considerados tendremos, debido a la constancia del volumen aceptada:

$$V_c = h' A'_m = h A_m \quad (7)$$

De acuerdo a la fórmula (2) el trabajo necesario para pasar de un cilindro

(\*) Las hipótesis simplificativas adoptadas aquí, equivalen a suponer que el trabajo redundante, requerido en el proceso de estirado, es igual al trabajo necesario para el cambio de forma de un cilindro de radio  $R_m + e$  a otro de radio  $R_m$ , siendo  $R_m$  el radio medio de la hilera y  $e$  una dimensión relacionada con la profundidad de las rugosidades y con el valor del abultamiento. En este caso el proceso sería continuo y no intermitente. Esto da otro método de deducción de la fórmula (9).

de sección  $A'm$  y longitud  $h'$  a otro de sección menor  $A_m$  y longitud mayor  $h$  será igual a:

$$W = \sigma_0 A'm (h - h')$$

Este trabajo será igual a la mitad del trabajo redundante asociado al tronco de cono de la hilera o sea:

$$T \cdot T' = \sigma_0 A'm (h - h')$$

Teniendo en cuenta la constancia del volumen  $V_c$  esta fórmula puede escribirse como:

$$T \cdot T' = \sigma_0 (A'm - A_m) \cdot h$$

Reemplazando el valor de  $h$  deducido de la fórmula (7) y llamando  $C$  al área de la corona circular determinada por  $A'm - A_m$  se tendrá:

$$T \cdot T' = \frac{\sigma_0 C V_c}{A_m}$$

Siendo  $e$  el espesor de la corona circular de área  $C$ , el valor de este área resulta con gran aproximación:

$$C = D_m \cdot e$$

De donde:

$$T \cdot T' = \frac{D_m e \sigma_0 V_c}{A_m} \quad (8)$$

Reemplazando este valor de  $T \cdot T'$  en fórmula (6) resulta:

$$\Delta P = \frac{2 D_m \sigma_0 e A_1}{A_m}$$

Por transformaciones matemáticas se llega a:

$$\Delta P = 4 \sqrt{2 \pi} \cdot \frac{\sigma_0 e A_1}{\sqrt{A_0 + A_1}}$$

que con gran aproximación puede escribirse:

$$\Delta P = 10 e \frac{\sigma_0 A_1}{\sqrt{A_0 + A_1}} \quad (9)$$

CONSIDERACIONES ACERCA DEL FACTOR e

El factor e de la fórmula (9) desempeña un papel similar al que, en las fórmulas basadas en la teoría clásica de la fricción desempeña el coeficiente de fricción.

La dimensión de e es, sin embargo, el de una longitud, por lo que su valor depende del sistema de unidades lineales adoptado, a diferencia del valor  $\mu$  que es adimensional.

El valor e depende, a la vez, de la profundidad de las rugosidades de hilera y de la magnitud lineal del abultamiento que se produce en el material a la entrada de una hilera. Ambos factores influyen en forma independiente en la determinación del trabajo redundante y ello introduciría un motivo de crítica a la fórmula (9).

Esto no obstante, la influencia de ambos factores puede ser representada por el coeficiente e de la fórmula (9) si suponemos que dicho valor es igual a la suma de dos términos: e' correspondiente a la rugosidad y e'' correspondiente al abultamiento.

Para la determinación del valor de estos términos partimos de la hipótesis de que ambos varían proporcionalmente con el incremento de la rugosidad de la hilera y que solamente el segundo término crece proporcionalmente con el aumento de las dimensiones lineales del tronco de cono de la hilera.

Por otra parte se supone que los restantes factores que intervienen en la magnitud del trabajo redundante influyen en forma equivalente en ambos términos, o cuando lo hacen en forma opuesta se autocompensan en las condiciones normalmente encontradas en la práctica.

En base a las experiencias analizadas en este trabajo, ha sido posible establecer que las suposiciones arriba mencionadas son correctas y que se puede asignar el siguiente valor para e:

$$e = e' + e'' = e' + e' (\sqrt{A_0 + A_1})$$

donde  $\sqrt{A_0 + A_1}$  representa la influencia del aumento de dimensiones lineales del tronco de cono de la hilera en el término e''.

Con esta consideración podemos modificar la fórmula (9) de la siguiente manera:

$$\Delta P = 10 e' \sigma_0 A_1 \left( \frac{1}{\sqrt{A_0 + A_1}} + 1 \right)$$

Para simplificar esta fórmula, llamaremos f al producto  $10 e'$  al que denominaremos "coeficiente de trabajo redundante".

De acuerdo con esto, la fórmula anterior puede expresarse:

$$\Delta P = \sigma_0 A_1 \left( \frac{1}{\sqrt{A_0 + A_1}} + 1 \right) f \quad (10)$$

### NUEVA FORMULA PARA EL CALCULO DE LA FUERZA DE ESTIRADO EN HILERAS

Sumando los esfuerzos correspondientes al cambio de forma y al trabajo redundante, se llega a la fórmula siguiente para el cálculo de la fuerza P requerida en los procesos de estirado:

$$P = P_0 + \Delta P = \sigma_0 (A_0 - A_1) + \sigma_0 A_1 \left( \frac{1}{\sqrt{A_0 + A_1}} + 1 \right) f \quad (11)$$

La diferencia fundamental de esta fórmula con otras utilizadas es la presencia del valor correspondiente a la resistencia de tracción  $\sigma_0$ , y la ausencia del valor del ángulo de la hilera. El valor de P resulta así dependiendo de una característica muy conocida del material: su resistencia a la tracción y del grado de reducción que se quiere aplicar en el proceso, además de un coeficiente cuya determinación experimental resulta sencilla para condiciones dadas de rugosidad de las paredes de la hilera y para características conocidas del lubricante. Las variaciones de este factor, para diferentes condiciones de trabajo y diferentes materiales, se analiza en el punto Interpretación de los Resultados.

Dado que el esfuerzo requerido en el proceso depende de la resistencia a la tracción antes del estirado, se puede aplicar esta misma fórmula a procesos realizados a distintas temperaturas y velocidades de deformación. Sólo será necesario determinar en cada caso el valor de  $\sigma_0$ , del material a la temperatura y velocidad de deformación del proceso.

En las fórmulas clásicas las características del material figuran con un coeficiente relacionado con la resistencia del material en los estados inicial y final del mismo. Debido a que la resistencia después del proceso puede variar mucho, dicho coeficiente no puede adoptarse como constante, aunque muchas veces se lo tome así. El valor inicial de la resistencia a la tracción es, por el contrario, siempre constante para un material dado, en igualdad de condiciones.

INFLUENCIA DEL ANGULO DE LA HILERA

Para una misma reducción de área, todas las fórmulas hasta ahora utilizadas expresan el valor de la fuerza de estirado en función de la magnitud del semi-ángulo  $\alpha$  del cono de la hilera.

Esa función no aparece expresada en la fórmula (11); ello podría hacer pensar que las hipótesis simplificativas que llevaron a la deducción de dicha fórmula, no son aceptables.

Se estima sin embargo que la influencia del ángulo  $\alpha$  sobre los coeficientes relacionados con el abultamiento y la rugosidad son de carácter opuesto y se autocompensan en la mayor parte de los casos encontrados en la práctica.

Las experiencias que se analizan más adelante, y que son interpretadas en el punto Interpretación de los Resultados, permiten establecer que la mencionada autocompensación es satisfactoria en la gran mayoría de los casos estudiados.

La figura 5, transcripta de un trabajo de Wistreich (1), y a la que se ha agregado la curva representativa de la fórmula (11), muestra que si se trazaron curvas correspondientes a los diversos ángulos utilizados, ellas se entrecruzarían, y que las diferencias entre los valores de Wistreich y los obtenidos con la fórmula (11) están, en general, dentro de lo que podría considerarse errores experimentales.

VERIFICACIONES EXPERIMENTALES

En el trabajo de S. Ya. Veler y V. I. Likhtman (3) figura una experiencia que, realizada con otra finalidad, representa una verificación experimental de la fórmula (3).

Mediante ensayos hechos en una hilera formada por rodillos libres de girar pudo determinarse el valor del esfuerzo de estirado sin fricción. Dichos autores trataron de encontrar una expresión para ese esfuerzo, con el fin de poder calcular el valor del esfuerzo correspondiente a la fricción y establecer una teoría sobre el mismo. Basándose en una fórmula primitiva de Sachs, que establece que el valor de  $P_0$  es igual a una cierta tensión vinculada con las características del material, multiplicada por  $(A_0 - A_1)$ , ellos encontraron, experimentando con varios materiales en distintas condiciones, que dicha tensión coincidía muy exactamente con la resistencia a la tracción del material, por lo que adoptaron para el esfuerzo de estirado sin fricción la expresión de nuestra fórmula (3).



Admitido como exacto el valor de  $P_0$ , se analiza -en las Tablas I a IX- una serie de experiencias ajenas, complementadas con experiencias propias (Tabla IX), destinadas a determinar el grado de exactitud de la fórmula (11).

El análisis realizado se refleja en las tablas mencionadas, en las cuales se ha determinado los valores teóricos de la fuerza de estirado y se los ha comparado con los valores experimentales.

La diferencia entre esos valores, expresada en porcentajes, figura en dichas tablas, como  $\Delta \%$ .

En las mencionadas tablas se han utilizado, además de los símbolos ya de finidos, los siguientes:

- $f_p$  = Promedio del coeficiente de trabajo redundante.
- $\Delta P_t$  = Fuerza debida al trabajo redundante calculada en base a  $f_p$ .
- $\Delta$  = Diferencia en kg entre la fuerza total teórica y la experimental.
- $r\%$  = Reducción de área, en por ciento.

Se ha puesto que, en cada experiencia, las condiciones de rugosidad de la hilera, y la efectividad de la lubricación han sido iguales y definidas por el valor de  $f_p$ , excepto para las experiencias de la Tabla VII, en las que se han utilizado dos tipos distintos de lubricantes.

### INTERPRETACION DE LOS RESULTADOS

Los valores de  $f_p$  varían en las distintas experiencias entre 0,04 y 0,25.

Esta diferencia se considera perfectamente justificada si se tiene en cuenta que, como se puede ver en la Tabla VIII, el simple cambio de lubricante, sin modificar ningún otro factor, hace variar la fuerza de estirado en un 20%, y que ello representa una variación para  $f_p$  entre 0,04 y 0,09.

El valor  $f_p = 0,25$  de las experiencias que figuran en la Tabla V corresponden a ensayos hechos con un lubricante inadecuado para los procesos de estirado, y que se empleó en ese caso por necesitarse un lubricante que pudiera ser aplicado a presión, con el fin de verificar la influencia de ésta en el valor del esfuerzo de estirado.

Cuando los valores de  $\Delta \%$  de las tablas son menores del 10% se conside-

ra que los mismos están dentro del grado de exactitud con que pueden realizarse los experimentos. De los cuatro casos, sobre un total de 48, en los que el error resulta superior al 10%, solamente uno, el correspondiente al ensayo 15 de la Tabla I, parece estar apreciablemente influenciado por la exactitud de la fórmula (11). Esta, como consecuencia de haber supuesto nula la influencia del ángulo de la hilera, parecería que tiende a dar valores bajos para condiciones de reducción pequeña y ángulo grande, como los correspondientes a ese ensayo.

Es de hacer notar, sin embargo, que el error que se obtiene en ese caso con la fórmula (11), (37,5%) es sensiblemente inferior al que obtiene Whitton (62%) para el mismo caso, a pesar de haber utilizado éste las fórmulas clásicas corregidas con un término adicional, completamente empírico deducido precisamente en base a las experiencias de Wistreich.

Difícilmente se dan en la práctica de estirado en hileras condiciones de ángulo y reducción de área como las correspondientes al ensayo 15 de la Tabla I.

En los otros tres casos, en que el error resultante de aplicar la fórmula (11) excede del 10%, las diferencias son mucho menores que en el caso anterior, y dichas diferencias se pueden considerar afectadas fundamentalmente por factores experimentales. El pequeño diámetro de los alambres empleados en dichos casos, hace que la influencia de los factores experimentales pueda incidir notablemente en los resultados.

### CONCLUSIONES

La fórmula (11), deducida por un procedimiento completamente distinto de los usuales, permite calcular con gran exactitud el valor de la fuerza requerida en los procesos de estirado en hileras.

La determinación del valor de  $f$ , para un tipo dado de lubricante y características también dadas de rugosidad superficial y geometría de la hilera puede hacerse simplemente en una máquina de ensayos de tracción, que es como se realizan los ensayos de la Tabla IX.

Mediante ensayos de este tipo pueden compararse cuantitativamente los resultados obtenidos al introducir, en los procesos de estirado, modificaciones relacionadas con el tipo de lubricante empleado, forma de la hilera y acabado superficial de la misma.

Para aplicaciones prácticas con los lubricantes e hileras utilizados corrientemente, puede adoptarse con gran aproximación el valor 0.1 mm para el factor  $f$ .

AGRADECIMIENTO

El autor agradece la colaboración prestada en la parte experimental de este trabajo por los ingenieros George Py y Juan E. Casanovas, y al Ing. Leoncio Falco por su ayuda en la corrección de los originales.

Igualmente agradece a las autoridades de la Facultad de Ciencias Exactas, Físicas y Naturales de la Universidad Nacional de Córdoba y de Industrias Kaiser Argentina, en cuyos laboratorios se han realizado los estudios y experiencias relacionados con el presente trabajo, por la colaboración prestada en la preparación del mismo.

REFERENCIAS

1. J. G. WISTREICH: "Proc. Inst. Mech. Eng." 1955, Vol. 169, núm. 35. Investigation of the mechanics of wire drawing.
2. P. W. WHITTON: "Wire industry". August 1958. The calculation of drawing force and die pressure in wire-drawing.
3. S. YA VEILER y V. I. LIKHTMAN: "Doklady Akademii Nauk SSSR". Vol. 114, 1957. Traducción inglesa por H. Brucher. Relaciones en el estirado de alambres metálicos en presencia de lubricantes.
4. H. G. BARON y F. C. THOMPSON: "J. Inst. Metals", 1950-51 (78), 415.
5. E. L. FRANCIS y F. C. THOMPSON: "J. Inst. Metals", 1931 (46), 313.
6. G. SACHS y K. R. VAN HORN: "Practical Metallurgy", 1949. Cleveland (0) (American Society for Metals).
7. HOFFMAN y SACHS: "Theory of Plasticity".
8. L. H. BUTTLER: "J. Inst. Metals", marzo 1960. The effect of interposed lubricants on the surface deformation of metals during plastic working.
9. V. F. MOSEEV y A. A. KOROSTELIN: "New Method of feeding lubricant to the deformation zone in wire drawing". Stal (edición inglesa), marzo 1962.
10. D. PUGH: "Metal Treatment", mayo, 1960. Cold deformation of metals.
11. C. T. YANG: "Trans Asmc", "J. Engng. Ing." 83 (1961).



Figura 1 Trabajo Redundante en la Deformación Plástica



Figura 2 Trabajo Redundante en la Fricción

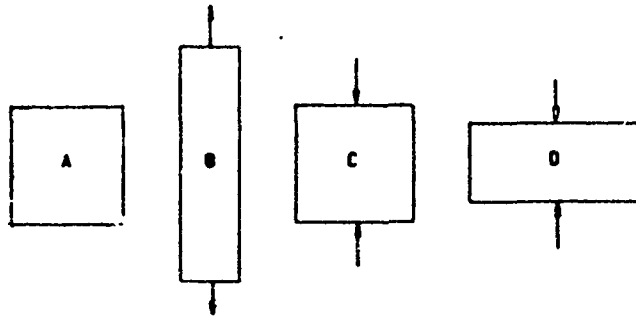

Figura 3 Diagramas de Tracción con y sin Estricción

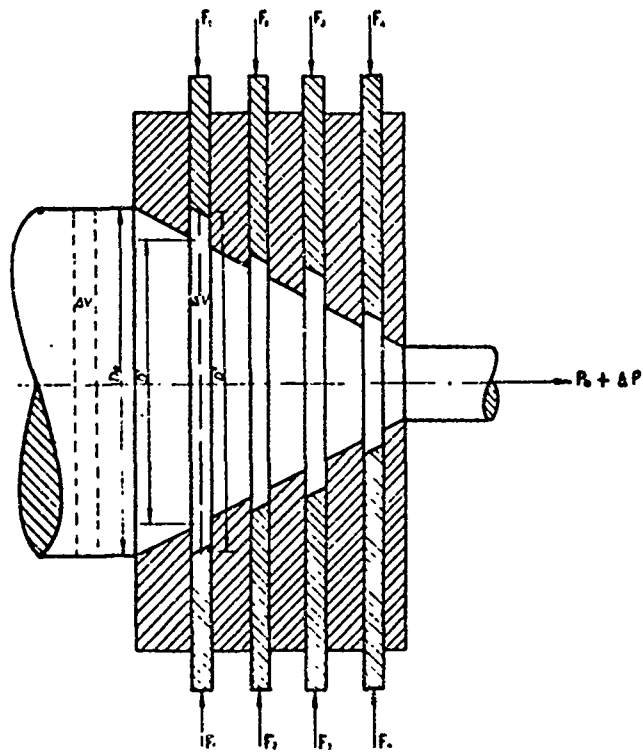

Figura 4 Trabajo Redundante por Abultamiento

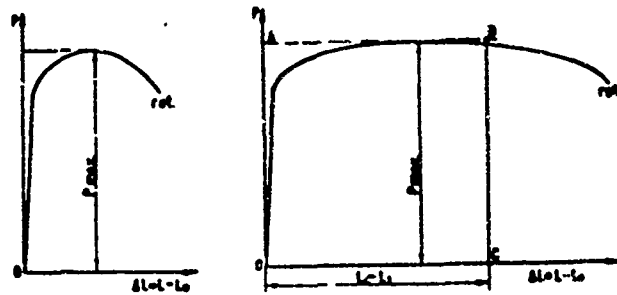

Figura 5 Experiencias de Wistreich Comparadas con la Fórmula (11)

XVIII-21

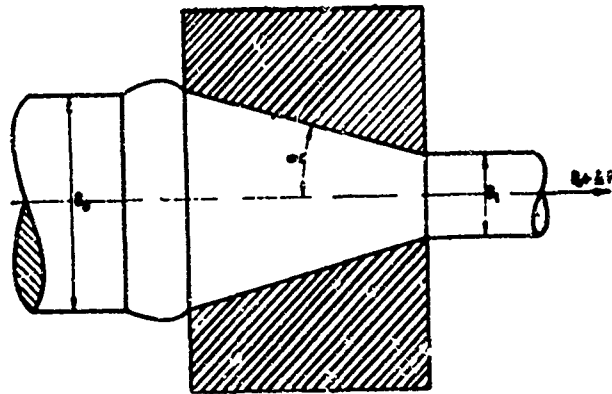
T A B L A I

Referencia: J. G. Wietrich(?). — Material: cobre endurecido — Resistencia a la tracción:  $\sigma_0 = 33 \text{ kg/mm}^2$ . — Lubricante: estearato de sodio. — Hileras: acero de herramientas.

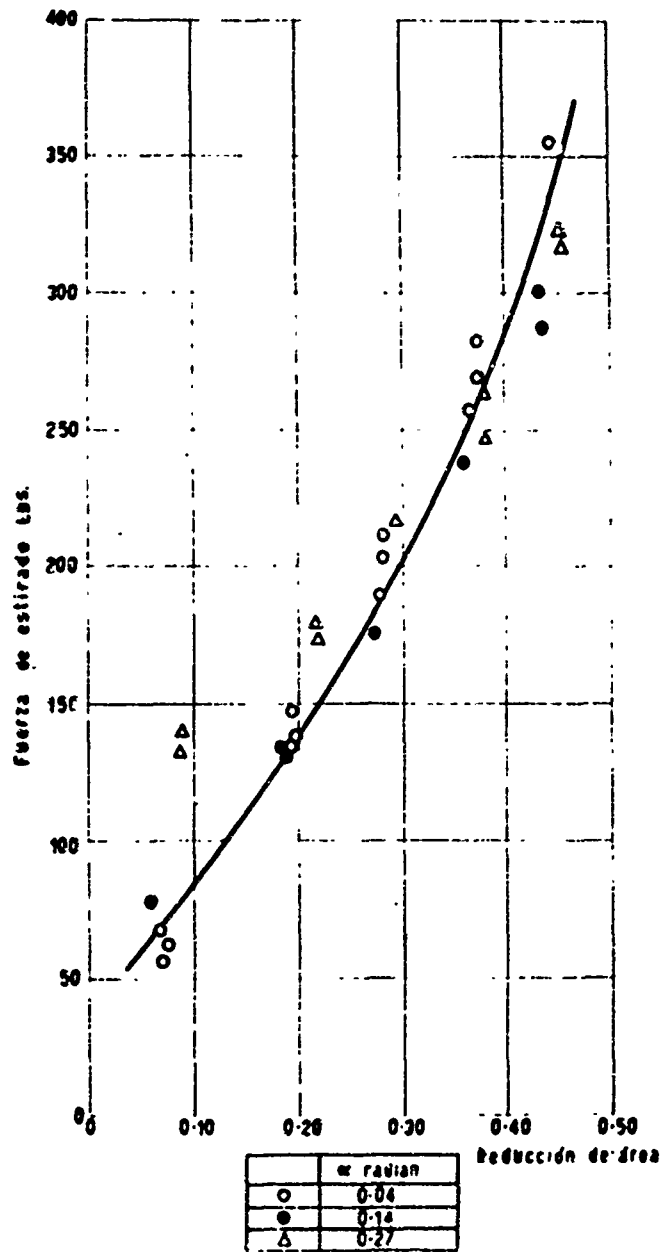
N.º	$A_0$ mm <sup>2</sup>	$A_1$ mm <sup>2</sup>	$A_0 - A_1$ mm <sup>2</sup>	$P_0$ kg	$P_{\text{app}}$ kg	$\Delta P$ kg	$\frac{\Delta P}{l}$ kg/mm	$l$ mm	$l_p$ mm	$\Delta P_l$ kg	$\Delta$ kg	$\Delta \%$	$\alpha$ grados	$\epsilon \%$
1	9,20	6,06	4,14	136,5	155,0	18,5	210	0,088	0,09	18,9	+ 0,6	+ 0,4	2,29	45
2	8,03	»	2,97	98,1	120,0	21,9	213	0,103	»	19,2	- 2,7	- 2,2	»	37
3	7,26	»	2,20	73,0	94,5	21,5	214	0,100	»	19,3	- 2,2	- 2,6	»	30
4	6,35	»	1,29	42,6	63,8	21,2	215	0,098	»	19,4	- 1,8	- 2,9	»	20
5	5,62	»	0,56	18,5	38,0	17,5	217	0,080	»	19,5	+ 2,0	+ 5,5	»	10
6	9,20	»	4,14	136,5	146,0	9,5	210	0,045	»	18,9	+ 9,4	+ 6,4	8,00	45
7	8,03	»	2,97	98,1	107,0	8,9	213	0,042	»	19,2	+ 10,3	+ 9,6	»	37
8	7,26	»	2,20	73,0	88,0	15,0	214	0,070	»	10,3	+ 4,3	+ 4,9	»	30
9	6,35	»	1,29	42,6	64,1	21,5	215	0,100	»	19,4	- 2,1	- 3,3	»	20
10	5,62	»	0,56	18,5	41,5	23,0	217	0,105	»	19,5	- 3,6	- 8,4	»	10
11	9,20	»	4,14	136,5	146,0	10,0	210	0,048	»	18,9	+ 9,4	+ 6,4	15,50	45
12	8,03	»	2,97	98,1	113,0	14,9	213	0,070	»	19,2	+ 4,3	+ 3,8	»	37
13	7,26	»	2,20	73,0	94,0	21,0	214	0,098	»	19,3	- 1,7	- 1,8	»	30
14	6,35	»	1,29	42,6	75,0	33,0	215	0,153	»	19,4	- 13,0	- 17,3	»	20
15	5,62	»	0,56	18,5	60,8	42,3	217	0,190	»	10,5	- 22,8	- 37,5	»	10

T A B L A II

Referencia: Francis and Thompson(?) (Tomado de P. W. Whitton(?)). — Material: cobre recocido — Resistencia a la tracción adoptada:  $\sigma_0 = 31 \text{ kg/mm}^2$ . — Lubricante: jabón. — Hileras: carburo de tungsteno sinterizado.

N.º	$A_0$ mm <sup>2</sup>	$A_1$ mm <sup>2</sup>	$A_0 - A_1$ mm <sup>2</sup>	$P_0$ kg	$P_{\text{app}}$ kg	$\Delta P$ kg	$\frac{\Delta P}{l}$ kg/mm	$l$ mm	$l_p$ mm	$\Delta P_l$ kg	$\Delta$ kg	$\Delta \%$	$\alpha$ grados	$\epsilon \%$
1	2,60	1,09	0,91	28,2	31,7	3,5	77,1	0,05	0,064	4,9	+ 0,5	+ 1,6	12	34,9
2	»	»	»	»	31,7	3,5	»	0,05	»	»	+ 0,5	+ 1,6	10	»
3	»	»	»	»	31,7	3,5	»	0,05	»	»	+ 0,5	+ 1,6	8	»
4	»	»	»	»	31,4	3,2	»	0,04	»	»	+ 0,8	+ 2,6	3	»
5	»	»	»	»	38,0	9,6	»	0,13	»	»	- 4,9	- 12,9	4	»

T A B L A III

Referencia: Francis and Thompson(?) (Tomado de P. W. Whitton(?)). — Material: latón 70:30 recocido — Resistencia a la tracción adoptada:  $\sigma_0 = 31,5 \text{ kg/mm}^2$ . — Lubricante: jabón. — Hileras: carburo de tungsteno sinterizado.

N.º	$A_0$ mm <sup>2</sup>	$A_1$ mm <sup>2</sup>	$A_0 - A_1$ mm <sup>2</sup>	$P_0$ kg	$P_{\text{app}}$ kg	$\Delta P$ kg	$\frac{\Delta P}{l}$ kg/mm	$l$ mm	$l_p$ mm	$\Delta P_l$ kg	$\Delta$ kg	$\Delta \%$	$\alpha$ grados	$\epsilon \%$
1	2,6	2,08	0,52	16,2	22,5	6,3	110	0,06	0,06	6,3	0	0	12	20
2	»	»	»	»	22,5	6,3	»	0,06	»	»	0	0	10	»
3	»	»	»	»	22,2	6,0	»	0,05	»	»	+ 0,3	+ 1,4	8	»
4	»	»	»	»	22,2	6,0	»	0,05	»	»	+ 0,3	+ 1,4	6	»
5	»	»	»	»	23,8	7,6	»	0,07	»	»	- 1,3	- 5,0	4	»

T A B L A IV

Referencia: Bacon and Thompson(?) (Tomado de P. W. Whitton(?)). — Material: latón 65:35 — Resistencia a la tracción adoptada:  $\sigma_0 = 35 \text{ kg/mm}^2$ . — Lubricante: jabón. — Hileras: carburo de tungsteno sinterizado.

N.º	$A_0$ mm <sup>2</sup>	$A_1$ mm <sup>2</sup>	$A_0 - A_1$ mm <sup>2</sup>	$P_0$ kg	$P_{\text{app}}$ kg	$\Delta P$ kg	$\frac{\Delta P}{l}$ kg/mm	$l$ mm	$l_p$ mm	$\Delta P_l$ kg	$\Delta$ kg	$\Delta \%$	$\alpha$ grados	$\epsilon \%$
1	2,10	1,534	0,566	19,8	23,2	3,4	82,3	0,04	0,11	9,0	+ 5,6	+ 24,3	5,5	27,0
2	»	1,322	0,778	27,2	34,5	7,3	71,3	0,10	»	7,8	+ 9,5	+ 1,4	5,0	37,0
3	»	1,112	0,988	34,6	44,8	10,2	60,6	0,17	»	6,7	- 2,5	- 7,5	3,0	47,0
4	»	1,122	0,978	34,2	43,1	8,9	61,2	0,14	»	6,7	- 2,2	- 5,1	4,4	46,5
5	»	1,092	1,008	35,3	43,3	8,0	59,6	0,13	»	6,5	- 1,6	- 3,5	6,1	48,0
6	»	1,186	0,914	32,0	38,5	6,5	64,7	0,10	»	7,1	+ 0,9	+ 1,5	11,0	43,5

T A B L A V

Referencia: V. F. Mossov y A. A. Korostelin(?). — Material: acero St 20 — Resistencia a la tracción:  $\sigma_0 = 65 \text{ kg/mm}^2$ . — Lubricante: mezcla de aceite lubricante y kerosene.

N.º	$A_0$ mm <sup>2</sup>	$A_1$ mm <sup>2</sup>	$A_0 - A_1$ mm <sup>2</sup>	$P_0$ kg	$P_{exp}$ kg	$\Delta P$ kg	$\frac{\Delta P}{l}$ kg/mm	$l$ mm	$l_p$ mm	$\Delta P_1$ kg	$\Delta$ kg	$\Delta\%$	$\alpha$ grados	$r\%$
1	3,00	1,04	0,36	23,4	65,0	41,6	162	0,28	0,25	40,8	-1,0	-1,5	12	17,8
2	>	1,495	0,506	32,8	70,0	37,2	149	0,25	>	37,2	0,0	0,0	>	25,4
3	>	1,30	0,70	45,5	77,0	31,5	131	0,24	>	32,8	+1,3	+1,7	>	35,0

T A B L A V I

Referencia: Hoffman y Sachs(?). — Material: acero para resortes — Resistencia a la tracción:  $\sigma_0 = 100 \text{ kg/mm}^2$ . — Lubricante: compuesto especial. — Hilera: carburos sinterizados.

N.º	$A_0$ mm <sup>2</sup>	$A_1$ mm <sup>2</sup>	$A_0 - A_1$ mm <sup>2</sup>	$P_0$ kg	$P_{exp}$ kg	$\Delta P$ kg	$\frac{\Delta P}{l}$ kg/mm	$l$ mm	$l_p$ mm	$\Delta P_1$ kg	$\Delta$ kg	$\Delta\%$	$\alpha$ grados	$r\%$
1	13	11,78	1,22	122	364	242	1412	0,172	0,19	208	+28	+7,1	5,6	16
2	>	10,52	2,48	248	495	247	1272	0,194	>	242	-5	-0,1	>	19
3	>	9,35	3,65	365	620	255	1137	0,224	>	216	-39	-6,4	>	28
4	>	8,32	4,68	468	627	199	1012	0,197	>	192	-7	-0,1	>	38
5	>	7,28	5,72	572	724	152	888	0,172	>	169	+17	+7,4	>	44

T A B L A V I I

Referencia: Veiler y Lichtman(?). — Material: cobre — Resistencia a la tracción:  $\sigma_0 = 35 \text{ kg/mm}^2$ . — Lubricante N.º 1: ácido oleico. — Lubricante N.º 2: solución al 5% de alcatraz de sodio.

N.º	$A_0$ mm <sup>2</sup>	$A_1$ mm <sup>2</sup>	$A_0 - A_1$ mm <sup>2</sup>	$P_0$ kg	$P_{exp}$ kg	$\Delta P$ kg	$\frac{\Delta P}{l}$ kg/mm	$l$ mm	$l_p$ mm	$\Delta P_1$ kg	$\Delta$ kg	$\Delta\%$	$\alpha$ grados	$r\%$
1	63,8	50,3	13,5	462	639	177	1920	0,09	0,09	7,3	7,3	21	21	21
2	63,8	50,3	13,5	462	541	79	1920	0,04	0,04	7,3	7,3	21	21	21

T A B L A V I I I

Referencia: C. T. Yang(?). — Material: aluminio — Resistencia a la tracción adoptada:  $\sigma_0 = 20 \text{ kg/mm}^2$ . — Lubricante: alhaxalde y aceite de máquina.

N.º	$A_0$ mm <sup>2</sup>	$A_1$ mm <sup>2</sup>	$A_0 - A_1$ mm <sup>2</sup>	$P_0$ kg	$P_{exp}$ kg	$\Delta P$ kg	$\frac{\Delta P}{l}$ kg/mm	$l$ mm	$l_p$ mm	$\Delta P_1$ kg	$\Delta$ kg	$\Delta\%$	$\alpha$ grados	$r\%$
1	26,82	25,70	1,12	11,2	43,9	32,7	292	0,112	0,105	30,7	-2,0	-4,6	10,1	4,07
2	28,00	>	2,30	23,0	58,3	35,3	>	0,121	>	>	-4,6	-7,9	>	8,11
3	30,18	>	4,48	44,8	74,9	30,1	>	0,108	>	>	-0,6	0,8	>	14,06
4	31,65	>	5,95	59,5	82,4	22,9	>	0,079	>	>	+7,8	+9,4	>	18,82

T A B L A I X

Referencia: experiencias propias hechas en una máquina universal de ensayos de 30 t. — Materiales: los indicados al pie de la tabla. — Lubricante: jabón común. — Hilera: acero de herramientas Rc 60. — Acabado superficial: 13 micro-inches.

N.º	$A_0$ mm <sup>2</sup>	$A_1$ mm <sup>2</sup>	$A_0 - A_1$ mm <sup>2</sup>	$P_0$ kg	$P_{exp}$ kg	$\Delta P$ kg	$A_0 + A_1$ mm <sup>2</sup>	$\frac{\Delta P}{l}$ kg/mm	$l$ mm	$l_p$ mm	$\Delta P_1$ kg	$\Delta$ kg	$\Delta\%$	$\alpha$ grados	$r\%$
1	284	241	43	1288	2000	712	525	7600	0,095	0,08	601	-111	-5,6	4	0,16
2	283	>	42	2915	4150	1345	524	16720	0,080	>	1345	0,0	0,0	>	>
3	281	>	40	2555	3620	1065	522	15880	0,066	>	1280	+215	+6,0	>	>

Material N.º 1: cobre recocido —  $\sigma_0 = 30 \text{ kg/mm}^2$ . — Resistencia a la tracción después del proceso: 32 kg/mm<sup>2</sup>.  
 Material N.º 2: acero de bajo carbono calibrado en frío —  $\sigma_0 = 67 \text{ kg/mm}^2$ . — Resistencia a la tracción después del proceso: 69 kg/mm<sup>2</sup>.  
 Material N.º 3: acero para herramientas recocido —  $\sigma_0 = 61 \text{ kg/mm}^2$ . — Resistencia a la tracción después del proceso: 75 kg/mm<sup>2</sup>.



REFINACION A FUEGO Y OTRAS SOLUCIONES PARA LOS PROBLEMAS  
PRESENTADOS POR LA PRESENCIA DE IMPUREZAS EN  
COBRE Y LATONES ALFA

Por H. J. Destailiats, E. Gerarduzzi, R. A. Morando\*

En nuestro país, las industrias de transformación de no-ferrosos, han sufrido durante los últimos años el efecto de una fuerte presión competitiva. Por ello, para disminuir sus costos, han intensificado el uso de rezagos -muchas veces en forma inadecuada- y esto ha traído aparejados una serie de problemas derivados de la impurificación de los productos obtenidos. Al mismo tiempo, el precio de los rezagos, sufrió una fuerte alza en relación al de los metales puros.

Así, el correcto aprovechamiento de una materia prima como el "scrap" de cobre, resulta un problema económico cuya solución sólo puede llegar por la vía técnica. Por eso algunas fábricas que no han seguido este camino se han encontrado fuera de competencia, por precio o por calidad.

Tratando de contribuir a solucionar este problema, que es de interés para el país en la medida en que puede significar un ahorro de importaciones y mejora de calidad, hemos trabajado sobre dos líneas relacionadas entre sí:

1. La puesta a punto de una técnica de refinación a fuego de cobre adaptada a las necesidades de fábricas transformadoras de tamaño medio.
2. El estudio, con miras a su aplicación industrial, de un método para eliminar el "hot shortness" producido por el plomo en cobre y latones.

A continuación pasamos a describir ambas técnicas.

---

\* Departamento de Metalurgia. Comisión Nacional de Energía Atómica.

1. Refinación a Fuego de Cobre en una Instalación Industrial de Mediana Capacidad

De los dos caminos universalmente usados para la purificación del cobre -electrólisis o refinación a fuego- hemos elegido este último por razones económicas.

Si bien es cierto que la electrólisis da directamente un producto de calidad, su costo, unido al de las dos fundiciones necesarias para llegar a la forma final a partir de re-agos, la hacen antieconómica.

La refinación a fuego da en una sola operación el producto terminado y, partiendo de scrap común, se puede obtener un producto cuya calidad resulta igual a la del otro proceso.

Por otra parte, en la Argentina, el gran mercado del cobre se encuentra en Buenos Aires, donde la energía eléctrica es cara y aún escasa.

Las principales impurezas que se presentan en el scrap de cobre, cuya fuente más común son conductores eléctricos en desuso, son: Pb, Sn, Fe, Zn, Al, Si, Ni.

De éstas, por sus efectos perjudiciales en el trabajado en caliente y por su relativamente difícil eliminación en la refinación pirometalúrgica, el Pb resulta el elemento más indeseable. Su presencia, sin embargo es muy común, originada en recubrimientos de cables, piezas estañadas con Sn-Pb, y a veces en cables protegidos con minio ( $Pb_3O_4$ ) que se reduce fácilmente con materia orgánica de revestimiento.

El Sn resulta también difícil de eliminar en comparación, por ejemplo, con el Fe, Zn, P o Al y produce aumento de endurecimiento por trabajado, y notable disminución de la conductividad eléctrica.

La manera en que las distintas impurezas afectan las propiedades físicas del cobre es bien conocida (1) y la mayor o menor facilidad relativa con que pueden eliminarse por oxidación está directamente relacionada con las energías libres de formación de los óxidos respectivos (2)(Fig. 1).

Previamente a la puesta a punto del proceso de fábrica se realizaron experiencias en escala de planta piloto en el laboratorio de Metalurgia del SATI-CNEA. En las mismas se estudió la introducción de variantes sobre el proceso clásico de oxidación-reducción con miras a adaptarlo a la escala y los medios disponibles en industrias de mediano tamaño.

Estas variantes son:

1. el uso de cloro como agente purificador;
2. la reducción con agentes gaseosos.

Describiremos su aplicación más adelante al hablar del proceso industrial.

### Ensayos en planta piloto

Se modificó un horno del tipo volcador a crisol, de manera de poder utilizarlo como horno de "batea" a fuego directo. En las figs. 3 y 4 se ve un esquema del mismo. En la parte postero-inferior se lo proveyó de una tobera cuyo diseño se muestra en la fig. 5. La capacidad del horno así modificado es de 50 kgs.

La fusión de la carga se produce en la posición de la fig. 3, o sea con la tobera fuera del nivel del líquido. Para hacer burbujear aire o los otros gases usados en el proceso, se comienza el pasaje de los mismos en esa posición y luego se baja el horno hasta llegar a la posición de la fig. 4.

En este horno se ensayaron las etapas de refinación y también el comportamiento de los distintos refractarios. Se estudió la eliminación de impurezas usando scrap de distintos orígenes y también agregándolas como ligas madres. Así hemos obtenido, a partir de una materia prima con un contenido de 97% de Cu muestras que responden a la especificación ASTM para cobre tough pitch.

Toda la experiencia recogida en el trabajo en escala piloto fué trasladada a la puesta a punto en planta de un horno de refinación semi-rotativo de 1500 kgs de capacidad. En la fig. 6 se puede ver un esquema del horno usado. En la misma se pueden apreciar las 3 toberas agregadas, similares a la descripta antes.

La operación consta de las siguientes etapas que son las clásicas y bien conocidas:

1. carga y fusión
2. oxidación
3. escoriado
4. reducción a tough pitch (o desoxidación)
5. colada

Además hemos introducido optativamente, antes o después de la reducción según el producto final deseado, una etapa de purificación por cloración.

Describiremos a continuación someramente cada una de estas etapas, deteniéndonos sobre los detalles novedosos o de mayor interés.

Fusión: Se conduce usando llama oxidante. Con esto se acorta bastante el período de oxidación posterior, ya que la incidencia directa de la llama contra el material aún no fundido tiene un efecto rápido. El combustible usado es diesel oil, de bajo contenido de azufre. En realidad esto es importante sólo después de la etapa de reducción, que es cuando el material puede absorber S.

Oxidación: Se inyecta aire a presión con las toberas en posición alta, y se gira el horno hasta obtener un fuerte burbujeo en el cobre. Este sistema tiene muchas ventajas sobre el método de burbujear aire por medio de caños de hierro. Además de resultar más cómodo, ahorra el consumo de caños y elimina la posibilidad de contaminación por Fe. Una vez solucionados algunos inconvenientes constructivos iniciales no han habido problemas de obturación de toberas. El proceso es seguido en la forma habitual, o sea, sacando muestras y observando las fracturas. El tiempo total en esta etapa es de alrededor de 1 hora, variando naturalmente con el tenor de impurezas presentes. Es necesario llegar a 0,6-0,7% de oxígeno, valor con el cual prácticamente se tiene una buena eliminación de impurezas hacia la escoria.

Escoriado: Se usa arena seca para ayudar a retirar la escoria. Es muy importante que no quede escoria en el horno ya que en la etapa de reducción pueden reincorporarse impurezas que contiene aquella.

Cloración: Comparando los valores de las energías libres de formación de los compuestos clorados de los elementos presentes como impurezas con la del  $\text{Cl}_2\text{Cu}_2$  (Fig. 2) se puede ver que la relación entre  $\text{Cl}_2\text{Pb}$  y la del  $\text{Cl}_2\text{Cu}_2$  es más favorable que las correspondientes a los óxidos respectivos. De aquí se puede inferir que la cloración del baño fundido podría resultar un método más eficiente para la eliminación del plomo que la oxidación. Existe al respecto una publicación (3) en la cual el autor trabaja con valores más bien altos de elementos aleantes. Nosotros hemos aplicado el método -sólo y en combinación con la oxidación- para la eliminación de cantidades máximas de 0,5% de Pb.

Además de la influencia de los valores termodinámicos citados, es importante hacer notar que el  $\text{Cl}_2\text{Pb}$  tiene un peso específico de 5,85. Esto hace que el  $\text{Cl}_2\text{Pb}$  que se forma, flote y sea fácilmente eliminado del sistema, condición que

que no se dá con los óxidos de Pb cuyo peso específico oscila entre 8,5 y 9 y cuya separación es más difícil por esta razón. En efecto, para que los óxidos sean eliminados es necesario que entren en contacto con la sílice de la escoria o, si se usa refractario ácido, de este último. Como el peso específico es similar al del Cu esta es una cuestión mecánica que generalmente debe ser resuelta por una agitación muy efectiva.

En la práctica hemos comprobado que efectivamente, la reacción del Cl con el Pb se verifica rápidamente. En el gráfico de la fig. 7 se puede ver la disminución del contenido de Pb en función del tiempo en un ensayo de cloración realizado sobre una carga sin oxidar. El valor final a que se llegó resultó menor que 0,005%.

Consideramos sin embargo que lo más conveniente es emplear la cloración como complemento de la oxidación, y no realizar toda la refinación a base de cloro debido a varias razones:

1. al precio del Cl contra el del aire comprimido;
2. al clorar siempre se forma  $\text{Cl}_2\text{Cu}$  y  $\text{Cl}_2\text{Cu}_2$ . Como estas sales son insolubles en el cobre fundido, pasan a la escoria formando una capa muy fluida y volátil que ocasiona cierta pérdida de Cu. En vez, en el proceso de oxidación el óxido cuproso que se forma se disuelve en el cobre y es recuperado en la etapa de reducción;
3. el efecto de eliminación de estaño por cloración (ver Fig. 7) es prácticamente nulo y esto hace que de todas maneras sea necesario pasar por la etapa de oxidación cuando este elemento está presente;
4. dado que siempre existen problemas toxicológicos con el uso del cloro, es preferible reducir su empleo a lo indispensable.

Cuando el producto final deseado es tough-pitch conviene hacer la cloración antes de reducir. La causa de esto es que el cloro puede modificar el equilibrio Cu-H-O que rige la cantidad de vapor de agua formado en el momento de la solidificación y variar así el nivel característico del lingote colado horizontalmente.

Por el contrario, si se quiere terminar con Cu desoxidado con P, no hay inconveniente en clorar después de reducir, con la ventaja de eliminar de este modo las impurezas que pudieran reincorporarse a causa de un escoriado deficiente.

El problema del ataque de los materiales de construcción por el cloro fue solucionado usando un tubo de cuarzo en lugar de hierro en la tobera. Los metales son violentamente atacados por el cloro caliente y por lo tanto no pueden ser usados.

### Reducción

Es conocida universalmente la utilización de palos verdes para reducir el contenido de oxígeno hasta el límite de 0,03 a 0,07% correspondiente al tough pitch. Sin embargo, existe actualmente una tendencia a usar agentes químicos reductores que permiten independizarse de los palos verdes cuyo empleo es muchas veces engorroso y aún antieconómico.

Por otra parte, en un horno relativamente chico como el que usamos, resulta muy difícil el empleo de madera para la reducción debido a que mientras es tán puestos los palos dentro del cobre no se puede encender el horno porque se quema la parte de aquellos que emerge.

Debido a la baja relación entre volumen y superficie con respecto a un hor no grande, la inercia térmica es poca o sea, dicho en otras palabras, el horno se enfría demasiado rápidamente y no da tiempo a completar la operación. Por el contrario, inyectando un reductor gaseoso por las toberas, se puede mantener al mismo tiempo el horno encendido y la temperatura no cae. Además resulta mucho más controlable la cantidad de material reductor que se inyecta, con lo que se disminuye el peligro de "pasarse" y también es más cómodo y limpio su empleo.

En 1962, S. S. Cole y L. W. Rowe describen la primera planta diseñada con éxito sobre esta base (4). En ella se emplea gas natural (metano) parcialmente oxidado como agente reductor. Prácticamente el gas usado resulta una mezcla de CO y H<sub>2</sub> como agentes activos, más un cierto porcentaje de N<sub>2</sub>. El gas natural no es usado en su estado original debido a su inactividad química. Su oxidación catalítica se realiza en una instalación de funcionamiento continuo que es descrita en el citado trabajo.

Nosotros, .. hemos usado una mezcla de alcohol metílico con gas natural o gas licuado, como vehículo. El dispositivo para su inyección es simple y puede verse en la fig. 8. Su costo es suficientemente bajo y puede adaptarse fácilmente a una instalación del tipo usado aquí. Su manejo es también relativamente sencillo y sin peligros siempre que se tomen las precauciones elementales.

La operación de reducción se comienza pasando gas solo y luego bajando las toberas hasta la posición de burbujeo. Recién entonces se abre la entrada de metanol controlando su caudal con un rotómetro. Se sigue el proceso de la reducción sacando muestras del mismo tipo que las usadas para la oxidación y además botones que permiten observar el "set".

Hemos contrastado las probetas mediante una técnica rápida de metalografía, empleando el procedimiento de pulido químico, pero la conclusión es que el mejor método para decidir cuándo la operación está terminada sigue siendo el del ojo experto, usado en el cobre con éxito desde hace unos 40 siglos.

Pasamos ahora a la segunda parte de este trabajo. En la misma describiremos los estudios hechos hasta el momento sobre los:

2. Efectos del Agregado de Uranio en Latones Alfa conteniendo Pb

Es conocido el efecto del plomo en la pérdida de ductilidad del cobre y latones que son laminados en caliente. La misma es explicada por la insolubilidad del plomo que a la temperatura de trabajado del material forma una fase líquida la cual provoca la pérdida de cohesión entre los granos al ser sometidos a tensiones mecánicas.

En algunos casos este efecto puede ser eliminado o disminuido por adición de ciertos elementos. Los mecanismos por los cuales actúan estas condiciones no son siempre los mismos, y están aún en discusión. Por ejemplo, pequeñas cantidades de bismuto como 0,001% causan el mismo efecto que el plomo en cobre laminado a temperaturas superiores a 270°C. Pero a muy altas temperaturas de trabajado, se tolera una mayor cantidad de bismuto. Según (5) el agregado de fósforo tiene un efecto beneficioso en estos mismos casos y algunos atribuyen estas variaciones a un cambio en la tensión superficial bismuto-cobre.

Otro caso parecido, descrito por Cottrell (6), es el de las adiciones de bismuto a latones conteniendo plomo. Según este autor debido también a un cambio de la tensión superficial entre el plomo-bismuto y el material base se mejora la ductilidad en caliente.

R. Thomson y J. O. Edwards (7) han trabajado con uranio como elemento adicionante, agregado en proporciones variadas con respecto al plomo. Así han conseguido eliminar el efecto de "hot shortness" en latones alfa. Según estos autores esto es explicado por la formación de un compuesto intermetálico uranio-plomo que tiene un punto de fusión más alto que la temperatura de trabajado.

Nuestro trabajo ha consistido en estudiar metalográficamente y en relación con su comportamiento mecánico, latones 70-30 con varios contenidos de plomo y uranio. Esto fue hecho con la intención de aclarar el mecanismo por el cual se produce el fenómeno y con miras a su posible aplicación industrial.

A continuación describiremos brevemente el procedimiento seguido para la obtención de las aleaciones ensayadas.

La fundición se realizó en un horno Tamman, en crisol de grafito y bajo atmósfera de argón. Se colocaron el latón y el plomo juntos y se llevaron a una tem

peratura de 1050°C; luego se introdujo el uranio en forma de láminas delgadas, envueltas en hojas de cobre. Se mantuvo a 1050°C durante 20 minutos agitando periódicamente y se coló en lingotera de hierro.

Los resultados obtenidos los podemos resumir de la siguiente manera:

1. Las muestras conteniendo hasta 0,3% de plomo pudieron ser laminadas en caliente sin dificultad, cuando se les agregó uranio en proporciones iguales y hasta triples del contenido de plomo (Fig. 11a, 11b). No así con contenidos menores de uranio que de plomo en cuyo caso se producen fisuras en las primeras reducciones (Fig. 11c).
2. Cuando se trabajó con 0,5% de plomo no fué posible evitar la pérdida de ductilidad, ni aún con agregados considerablemente mayores de uranio. Tampoco tuvo efecto alguno la variación de otros factores como el aumento del tiempo de contacto con el metal líquido.

Si bien la necesidad de una relación mínima uranio/plomo = 1 parece abogar la idea de la formación de un intermetálico, nosotros no hemos podido detectar metalográficamente el menor vestigio del mismo.

Por el contrario, las únicas fases que aparecen son las  $Cu_5U$ , de color celeste y ubicada interdendríticamente y el plomo, precipitado como placas de color oscuro. La primera resulta idéntica a la obtenida en una muestra con 3% de uranio pero libre de plomo, como puede verse en las micrografías de la fig. 9.

Además la distribución relativa de las fases  $Cu_5U$  y Pb es la misma en todas las probetas (Fig. 10) de modo que no se explica por qué razón el supuesto intermetálico dejaría de formarse al aumentar el contenido de plomo de 0,3 a 0,5%.

## CONCLUSIONES

Aunque el estudio realizado no nos permite aún enunciar una teoría fundamentada al respecto, la ubicación de una fase  $Cu_5U$  en los límites de grano nos hace pensar que el efecto puede ser debido al desplazamiento del plomo de esa posición o bien al cambio de las tensiones interfaciales por formación de este compuesto. Ninguna de estas teorías explica sin embargo porqué con contenidos de 0,5% de plomo el fenómeno desaparece.

Creemos que este método puede llegar a ser una técnica interesante para ser utilizada industrialmente sobre todo como complemento de otras técnicas de refinación de cobre con altos contenidos de impurezas. La principal dificultad



que vemos para esta aplicación es que debido a la gran reactividad del uranio se producen pérdidas importantes de este elemento cuando se lo agrega en un crisol con material fundido al aire y por lo tanto serían necesarias técnicas especiales de fundición para su uso exitoso.

B I B L I O G R A F I A

- (1) Butts, Copper, the metal, its alloys and compounds (1954) p. 410
- (2) AFS New Technology, Oct. 1961, p. 459.
- (3) J. Muller W. Buchen Die Verwendung von gas förmigen Raffination-smitteln beim Schmelzen von Kupfer usw. Giesserei 27 August 1959.
- (4) Trans. AIME, April 1962.
- (5) Effect of Residual Elements on the Properties of Metals, F. N. Rhines, p. 63
- (6) Metalurgia Física, Cottrell, p. 142.
- (7) Hot Workability of Alpha brasses - R. Thomson and J. O. Edwards.

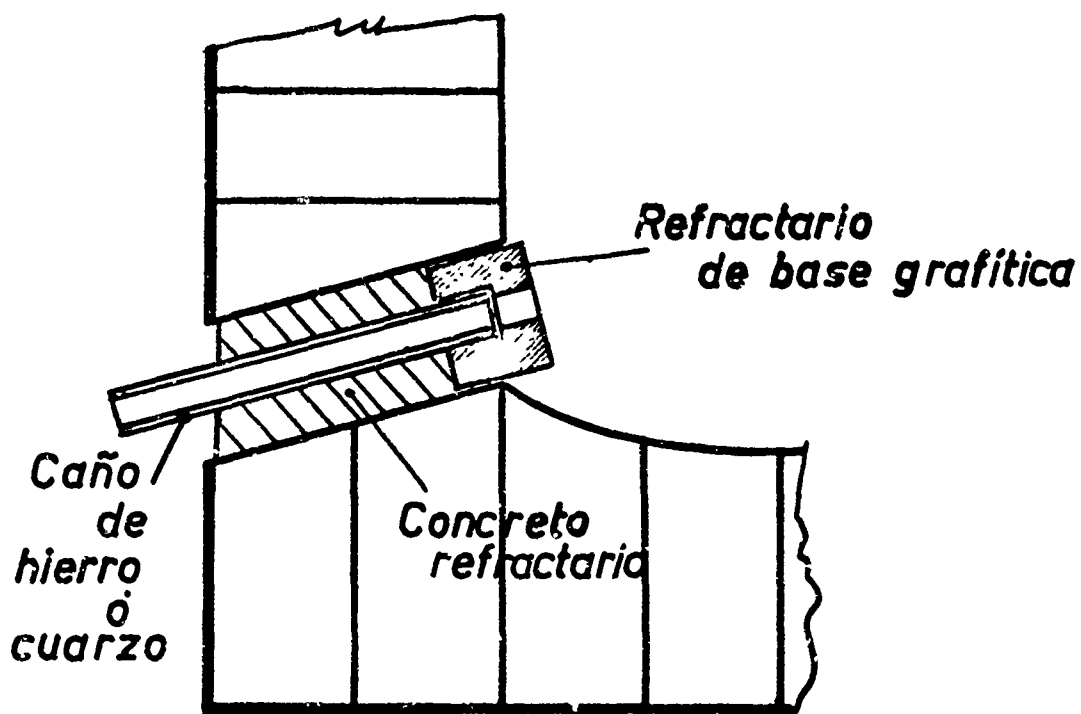
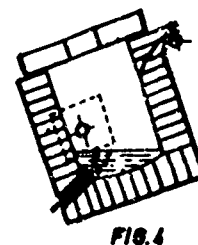
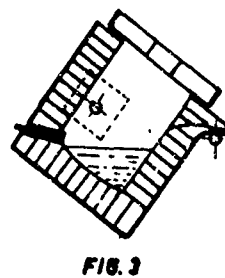
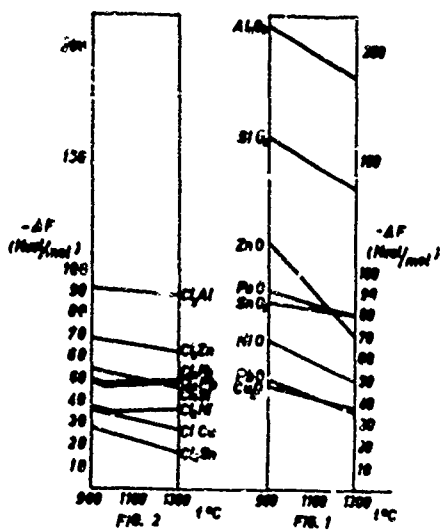

FIG. 5

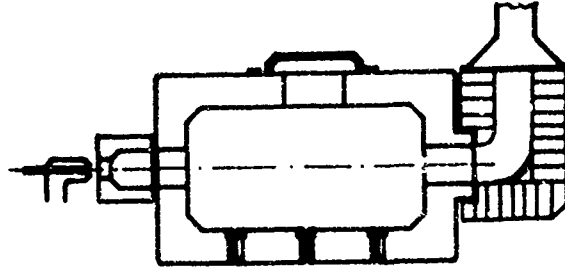

FIG. 6

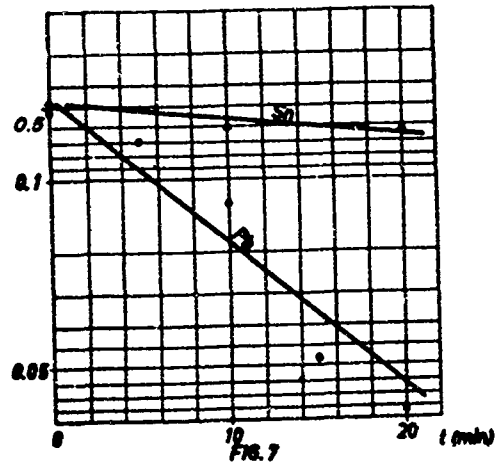

FIG. 7

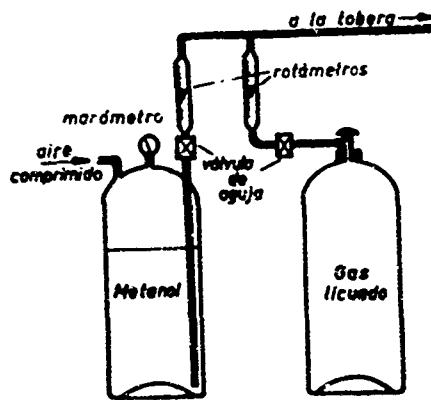

FIG. 8

XIX-12

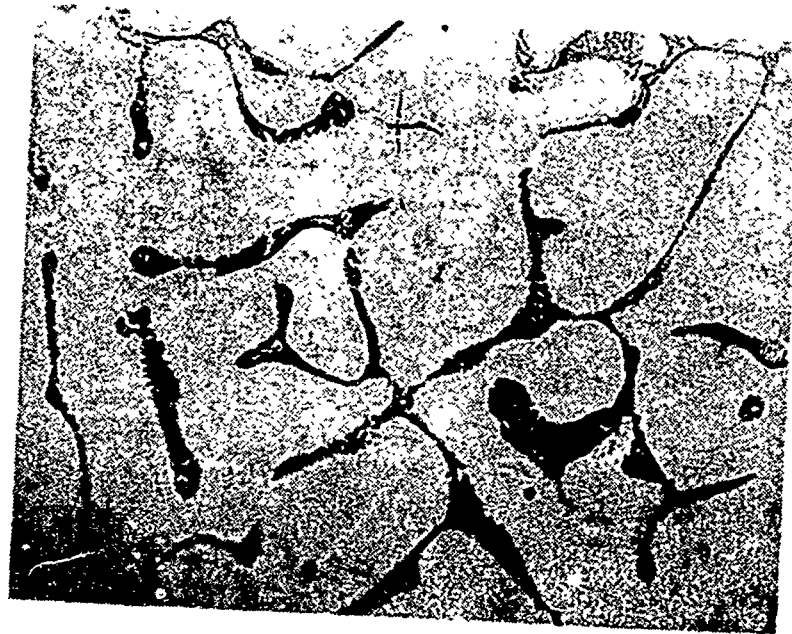

Fig. 9: Cu U (3%) 800 x

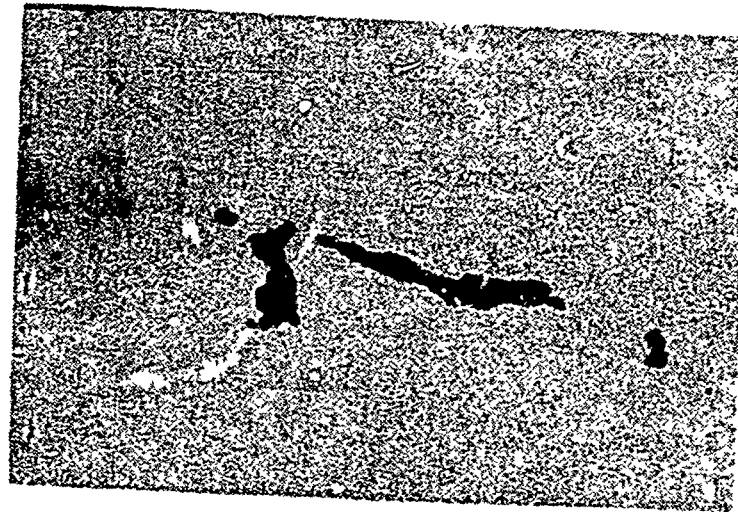

Fig. 10 : Latón 70-30 - Pb 0,3%; U 0,9% 1000 x

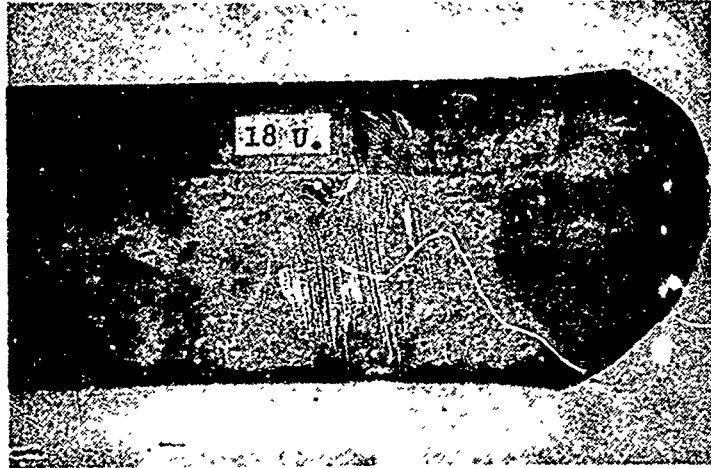

Fig. 11a : Latón 70-30. Pb 0,3%; U 0,9%

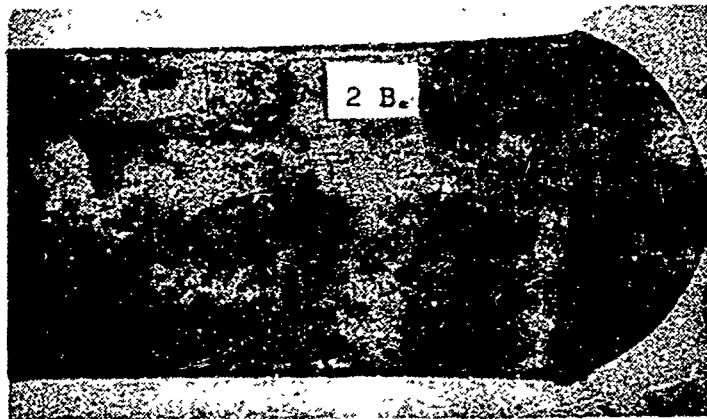

Fig. 11b : Latón 70-30. Pb 0,3%; U 0,3%



Fig. 11c : Latón 70-30 . Pb 0,5%; U 1%

ESTUDO SÔBRE A DETERMINAÇÃO DE ALGUMAS CARACTERÍSTICAS  
RESIDUAIS DAS AREIAS DE MOLDAGEM

Quim. Victor Lo Ré (\*)

RESUMO - O presente trabalho visa estudar a possibilidade de estabelecer um método de ensaio, que permita a determinação de algumas características residuais nas areias de moldagem, após seu contato com o metal líquido. Estas determinações, efetuadas em corpos de prova padrão, ajudam a esclarecer o comportamento da areia durante o enchimento do molde. As características apresentadas pelas areias, depois de submetidas a ação do metal líquido, poderão servir de orientação para um melhor controle das adições de aglomerantes e aditivos às areias de moldagem. As experiências nos levaram a concluir que o método é susceptível a modificações embora demonstrasse a exequibilidade do processo. O método permite estabelecer algumas correlações com resultados obtidos em outros tipos de ensaio.

1. INTRODUÇÃO

Os ensaios das areias de moldagem, à alta temperatura, são normalmente efetuados em laboratório, com o emprego do dilatômetro. Este consiste essen-

---

(\*) Responsável da Seção de Areias e Materiais de Moldagem do Instituto de Pesquisas Tecnológicas; São Paulo, SP.

cialmente de u'a máquina de ensaio a compressão a quente, onde o corpo de prova e o dispositivo de transmissão de esforço ficam localizados em um forno aquecido eletricamente. A câmara do dilatômetro deve satisfazer às seguintes condições: temperatura uniforme e regulável e capacidade térmica para restabelecer a temperatura rapidamente depois de colocado o c.p. (fig. 1).

Diversos trabalhos têm sido apresentados, modificando a técnica de ensaio a altas temperaturas, porém, sempre utilizando o dilatômetro como instrumento de medida (1). Consistiu em exceção um trabalho apresentado por Woodliff, "Mold surface behavior", sobre a medida da expansão das areias, em que o corpo de prova de areia é envolvido pelo metal, e a medida é feita utilizando-se um defletômetro ligado por uma haste de quartzo apoiado no c.p. que transmitirá as variações da altura do c.p. (2). O ensaio assim realizado nos parece mais interessante comparado ao método do dilatômetro, pois que estando a areia em contacto direto com o metal, traduz resultados mais próximos do trabalho real na fundição. Diante destas observações, pareceu interessante tentar desenvolver um método que permitisse determinar algumas características residuais das areias de moldagem, após terem sido submetidas à ação do metal líquido.

Assim, foi estudada inicialmente a possibilidade de se determinar a resistência mecânica residual, a permeabilidade e a dureza superficial. O aparelhamento de medida consistiu em u'a máquina universal para ensaio de resistência de areias de moldagem, um permeâmetro e um medidor de dureza. Estes aparelhos são facilmente encontrados em laboratórios de areia de fundição, ao contrário do dilatômetro que, pelo seu alto custo, somente pode ser adquirido por fundições de grande porte. Os corpos de prova utilizados foram preparados a partir de areia de composição conhecida, em medida padrão, e de acordo com métodos padronizados. Algumas caixas para conter os corpos de prova foram estudadas e utilizadas no decorrer deste estudo. A maior dificuldade deste trabalho consistiu no preparo de caixas adequadas para conter e submeter os corpos de prova ao contacto com o metal líquido, sem que os mesmos se danificassem ao serem retirados para ensaio.

Diversas tentativas foram feitas, alterando-se o tipo de caixa, e evoluindo para um sistema prático que eventualmente poderia vir a ser padronizado.

## 2. APARELHAMENTO E ENSAIO

Foram os seguintes os aparelhos utilizados para a realização do ensaio:

1. Máquina Universal H. Dietert, empregada para a determinação de resistência em c.p. úmidos, secos ou estufados. Consiste essencialmente em um braço-motor e pêndulo que giram em torno de um eixo montado em base pesada, com suportes articulados para receber o c.p.
2. Permeâmetro Dieter. Consiste em um depósito cilíndrico com água, no qual flutua, disposto telescopicamente, um tambor, em borbado em água de modo a reter volume de ar superior a 2.000cm<sup>3</sup> sob pressão estática de 10 g/cm<sup>2</sup>, tubulação de cerca de 5mm de diâmetro, e pondo em comunicação o ar com a cuba contendo mercúrio, onde é colocado o c.p. manômetro ligado a cuba de mercúrio com ábaco espiralado onde é feita a leitura direta da permeabilidade.
3. Esclerômetro. Utilizado para determinar a dureza superficial em c.p. secos. Penetrador em forma de faca.

Os métodos de ensaio e detalhes de aparelhamento são descritos nos métodos de ensaio M-32 a M-46 do IPT (3). Os corpos de prova foram preparados de acordo com o método M-36 IPT, nas dimensões de 50,8 mm de altura por 50,8mm de diâmetro.

### 3. COMPOSIÇÃO DAS AREIAS ESTUDADAS

Os corpos de prova foram obtidos a partir de misturas dos seguintes tipos de areia preparados de acordo com a técnica recomendada (4):

- a) Areia estufada para machos e moldes;
- b) Composição modificada de a); e
- c) A mesma composição de a) com adição de serragem.

Nos casos b e c as modificações deliberadamente introduzidas foram no sentido de verificar comparativamente a diminuição da resistência residual e conseqüentemente a colapsibilidade. A areia a) é normalmente empregada para a fundição de peças de ferro fundido comum, as areias tipo b) e c) são utilizadas



para ferro fundido de alto silício (Duriron).

Composição	a	b	c
Areia do mar (mod. 90-100) kg	100	100	100
Argila	4	4	4
Mogul	1,5	-	1,5
Dextrina	-	2	-
Oleo (oiticica)	2	1	2
Água	5	5	5
Serragem			1
<b>Características</b>			
<u>C.p. úmidos</u>			
Umidade (%)	5	5	5
Permeabilidade (AFS)	40	45	46
Resistência a compressão (kg/cm <sup>2</sup> )	2,8	3,5	2,1
Dureza	60	55	45
Deformação (%)	3,0	3,5	3,0
<u>C.p. secos - 22(1) C - 3h</u>			
Resistência a compressão (kg/cm <sup>2</sup> )	19	19	19
Permeabilidade (AFS)	60	60	65
Dureza (AFS)	100	95	80

#### 4. ENSAIO

Para a execução do ensaio, foram preparadas caixas de areia, nas medidas de 355 x 455 x 100 mm, nas quais foram montados os corpos de prova com separadores, também de areia. Os corpos de prova são envolvidos por 1 cm de (figs. 2-2a e 3).

Procedido o vazamento, após a caixa fria, desmolda-se cuidadosamente, retirando-se os corpos de prova que estão envolvidos pelo metal solidificado. Esta operação é facilitada pelos separadores de areia como poderá ser visto nas figs. 2 e 3.

Este tipo de montagem, entre outros, tem o inconveniente de obrigar ao vazamento individual de cada c.p. e ainda por setor isolado pelos separadores. Não fôra só o inconveniente da morosidade do processo, acresce ainda que as condições de vazamento podem se alterar para cada corpo de prova no que se refere a temperatura e velocidade de vazamento, dificultando assim uma padronização do

ensaio. Este tipo de caixa poderá eventualmente servir para serem observadas as reações metal-areia.

Resultados obtidos com o 1º tipo de caixa (fig. 3):

1a. Série - Areia tipo a:

Temperatura inicial  
de vazamento  
1300º C

Permeabilidade (AFS)	50	60	50	45	48	60	50
Resistência à compressão (kg/cm <sup>2</sup> )	4,9	4,3	4,5	3,9	3,5	2,1	
Dureza (AFS)	49	45	49	47	42	40	45

2º Série - Areia tipo a:

Temperatura inicial  
de vazamento  
1280º C

Permeabilidade (AFS)	67	65	62	55			
Resistência à compressão (kg/cm <sup>2</sup> )	4,5	3,1	4,2	3,5	2,2		
Dureza (AFS)	49	45	49	42	40		

3a. Série - Areia tipo b:

Temperatura inicial  
de vazamento  
1290º C

Permeabilidade (AFS)	63	65	45	50	45	30	
Resistência à compressão (kg/cm <sup>2</sup> )	8,4	3,5	4,9	2,2	2,1	2,5	
Dureza (AFS)	50	52	49	49	45	40	

No sentido de corrigir as deficiências do processo anterior, várias caixas foram estudadas, evoluindo para a confecção de uma placa com canal central de alimentação, permitindo desta forma o vazamento simultâneo de seis c.p., e reproduzindo aproximadamente o trabalho de uma areia em uma caixa de fundição. Inicialmente foi usado o modelo da fig. 4, modificado conforme pode ser visto na

fig. 5, na parte referente aos canais, visando desta forma a retirada mais fácil dos c.p. Nêstes dois últimos processos o vazamento é feito em caixa fechada, ao contrário do primeiro que era em caixa aberta. O número de separadores foi reduzido a 2.

Resultados obtidos com o 2º tipo de caixa (fig. 4):

1a. Série - Areis tipo a:

Temperatura inicial  
de vazamento  
1300º C

Permeabilidade (AFS)	50	50	48	49	52
Resistência à compressão (kg/cm <sup>2</sup> )	3,5	4,2	4,8	4,7	4,5
Dureza (AFS)	60	65	64	62	59

2a. Série - Areia tipo b:

Temperatura inicial  
de vazamento  
1300º C

Permeabilidade (AFS)	-	-	-	-	-
Resistência à compressão (kg/cm <sup>2</sup> )	2,1	2,2			
Dureza (AFS)	40	50	45		

Resultados obtidos com o 3º tipo de caixa (fig. 5):

1a. Série - Areia tipo a:

Temperatura inicial  
de vazamento  
1280º C

Permeabilidade (AFS)	45	48	50	45
Resistência à compressão (kg/cm <sup>2</sup> )	4,2	3,6	4,1	
Dureza (AFS)	35	45	45	35

2a. Série Areia tipo c:

Temperatura inicial  
de vazamento  
1280° C

Permeabilidade (AFS)	-	-	-	-	-
Resistência a compressão (kg/cm <sup>2</sup> )	2,1	1,9	1,7		
Dureza (AFS)	40	30	40		

Areia tipo b (não foi possível a determinação)

Nestes dois últimos tipos de caixa, a retirada dos corpos de prova de areia de baixa resistência (b e c) foi muito difícil. Para c.p. de resistência abaixo de 3 kg/cm<sup>2</sup>, é aconselhável o 1º tipo de caixa (caixa aberta), pois os três separadores de areia permitem a retirada dos espécimes mais facilmente, sem danificá-los.

Um novo estudo dos projetos das caixas tipo 4 e 5, com a montagem de 3 separadores de areia, deverá permitir a fácil retirada dos c.p., com a vantagem do vazamento uniforme.

Como primeiro estudo foi tentada uma nova forma de alimentação vista nas figs. 6, 7 e 8.

Resultados obtidos com o 6º tipo de caixa:

Areia tipo a:

Temperatura inicial  
de vazamento  
1300° C

Permeabilidade (AFS)	70	68	68	68
Resistência à compressão (kg/cm <sup>2</sup> )	6,3	6,5	6,3	6,2
Dureza (AFS)	70	80	80	70

Areia tipo b:

Temperatura inicial de vazamento 1300° C		
Permeabilidade (AFS)	50	48
Resistência à compressão (kg/cm <sup>2</sup> )	2,8	3,0
Dureza (AFS)	45	45

A desmoldagem dos corpos de prova processou-se sem dificuldade, permitindo a retirada dos mesmos sem danificá-los. Como apenas uma experiência foi efetuada, os resultados deverão ser confirmados em mais alguns vazamentos. Na fig. 9 podemos observar o último tipo de placa utilizada para o preparo de caixas. Note-se os quatro separadores de areia visando facilitar a retirada dos corpos de prova.

Menos do que a obtenção de resultados precisos, em grande número, o objetivo principal deste trabalho foi verificar a exequibilidade do ensaio através do estudo das caixas para conter os corpos de prova e a possibilidade de se obter resultados reprodutíveis para c.p. nas mesmas condições de vazamento.

## 5. CONCLUSÕES

1. A tentativa para estabelecer um método inédito de ensaio é suscetível de modificações, sendo necessário prosseguir os estudos.
2. Será aconselhável o estudo do efeito da aplicação de carga de compressão nos corpos de prova submetidos ao contato direto com o metal líquido, no momento do vazamento.
3. Os valores obtidos para a resistência residual permitem estabelecer uma correlação com a colapsibilidade no caso das areias para macho.

4. O conhecimento das características residuais de uma areia de moagem permite um melhor controle na adição de aglomerantes e aditivos visando efeitos especiais, inclusive na aplicação de pinturas.
5. Os resultados obtidos permitirão, em estudo futuro, estabelecer comparação com outros resultados obtidos em ensaios de alta temperatura realizados com o dilatômetro.
6. Dos estudos realizados poderão resultar tipos de ensaios, permitindo a observação da areia após seu efetivo uso, de forma mais evidente do que os ensaios efetuados no dilatômetro.
7. Os resultados obtidos autorizam a afirmar que o campo fica aberto ao estudo de inúmeras composições de areia, onde argilas e outros aditivos podem ser analisados em face da resistência residual, correlacionando o seu comportamento com a colapsibilidade.
8. As reações metal-areia poderão vir a ser estudadas pelo método descrito.
9. O método estudado é econômico, prático, e pode ser usado na maioria das fundições.

BIBLIOGRAFIA

1. HEINE, R.W., SCHUMACHER, J.S., KING, E.H. - Molding and core sand high temperature testing. Transactions AFS - v.69 1961.
2. ROBERTS DAN & WOODLIFF EARL, E. - Mold surface behavior. Transactions AFS - 1958, pg.74.
3. Métodos de ensaio elaborados peio Instituto de Pesquisas Tecnológicas de São Paulo. M-31 a M-46.
4. LO RE, V. - Prática no preparo de areias sintéticas para ferros fundidos. ABM - Boletim, v.16, nº58.

AGRADECIMENTO

Queremos deixar aqui consignado o nosso agradecimento ao Eng. Dr. Luiz C. Corrêa da Silva, Eng. Chefe da Divisão de Metalurgia do IPT, pela sua cooperação no decorrer dêste trabalho, através das sugestões feitas.

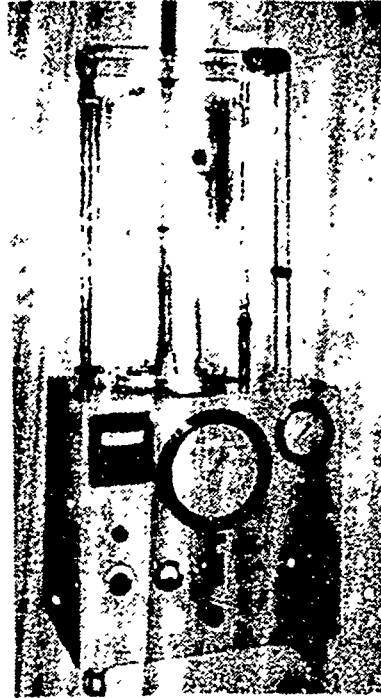

Fig. 1 Aspecto do dilatometro para ensaio de areias de moldagem a altas temperaturas. Consiste essencialmente num dispositivo de compressao a quente; o corpo de prova fica localizado no forno superior, aquecido eletricamente.

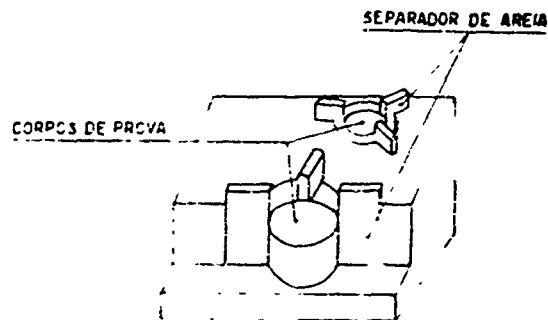

Fig. 2 Caixa de areia individual para ensaio do corpo de prova de areia de moldagem; veem-se os separadores de areia



"X 1.



Aspecto fotográfico da caixa de atoma da figura anterior. Os corpos  
-b- prov. são envolvidos por uma camada de membr. de 1 cm  
de espessura

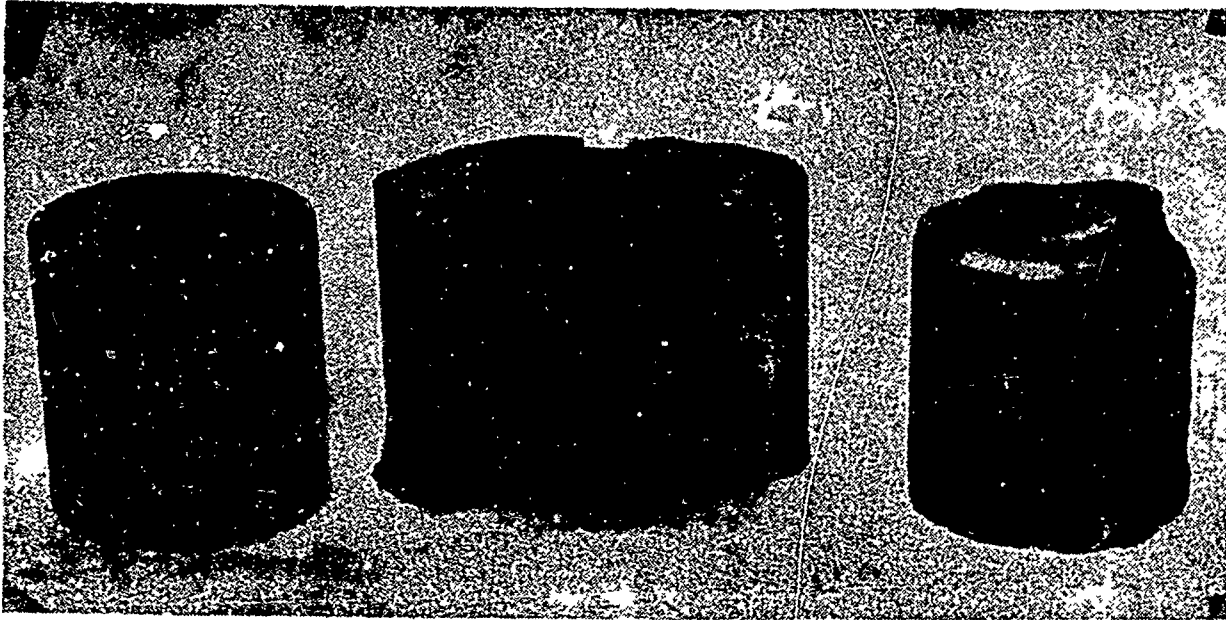

Fig. 3 Aspectos dos corpos de prova da experiencia da figura anterior

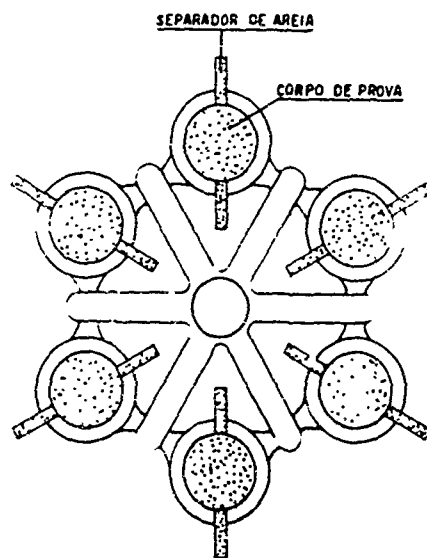

Fig. 4 A caixa das figuras 2 e 3 evoluiu para uma placa com canal central de alimentação; permite o vazamento simultaneo de 6 corpos de prova e se aproxima mais de uma fundição real

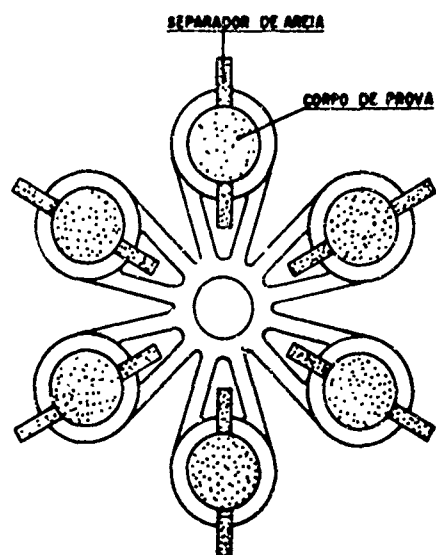

Fig. 5 A placa da figura anterior foi melhorada na parte referente aos canais; visando a retirada mais fácil dos corpos de prova

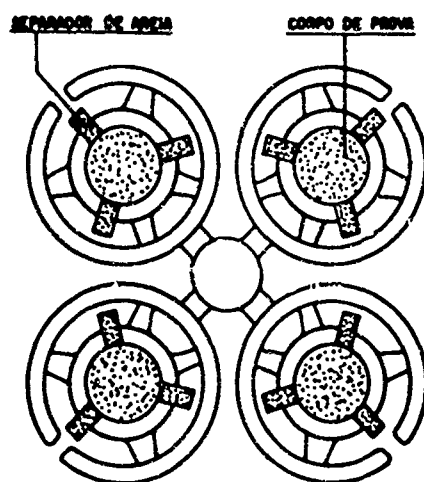

Fig. 6 Nova forma de alimentação foi tentada; a desmoldagem dos corpos de prova processou-se sem dificuldade. Os ensaios prosseguem com esta nova caixa

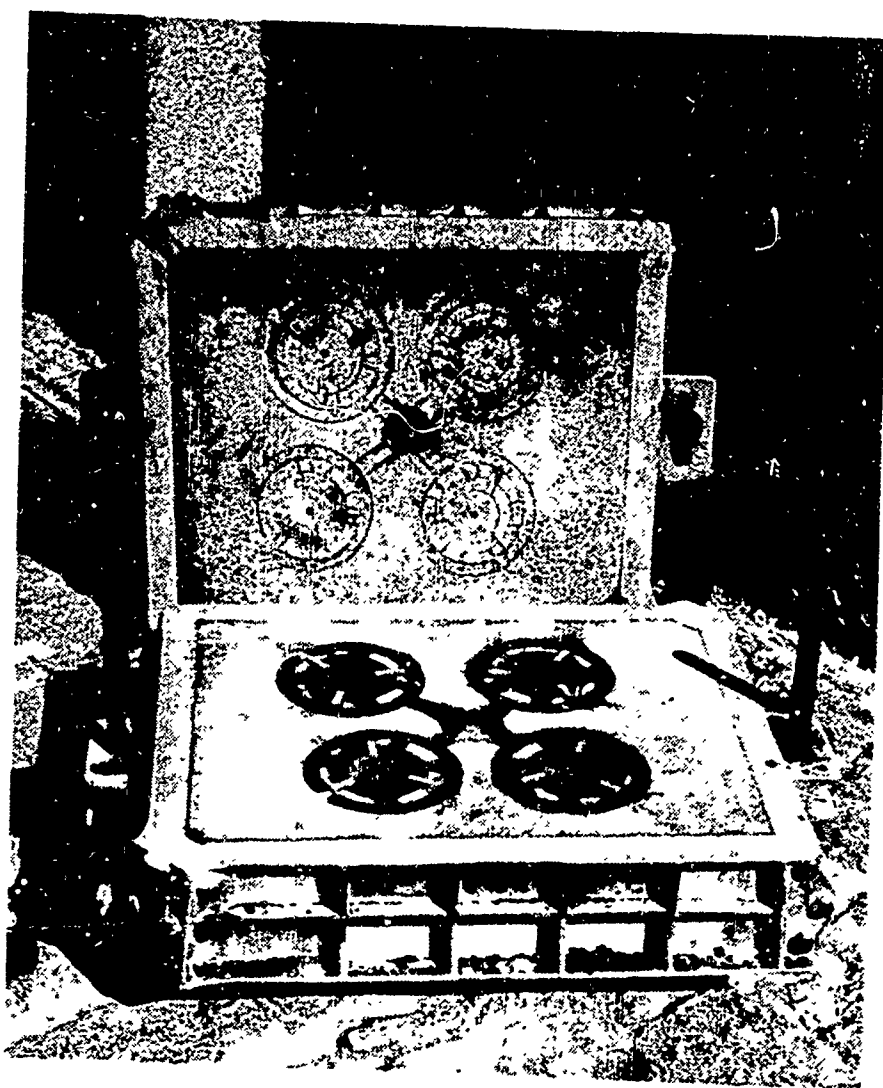

Fig. 7 Vista fotogrfica da caixa da figura 6, ainda nao desmoldada

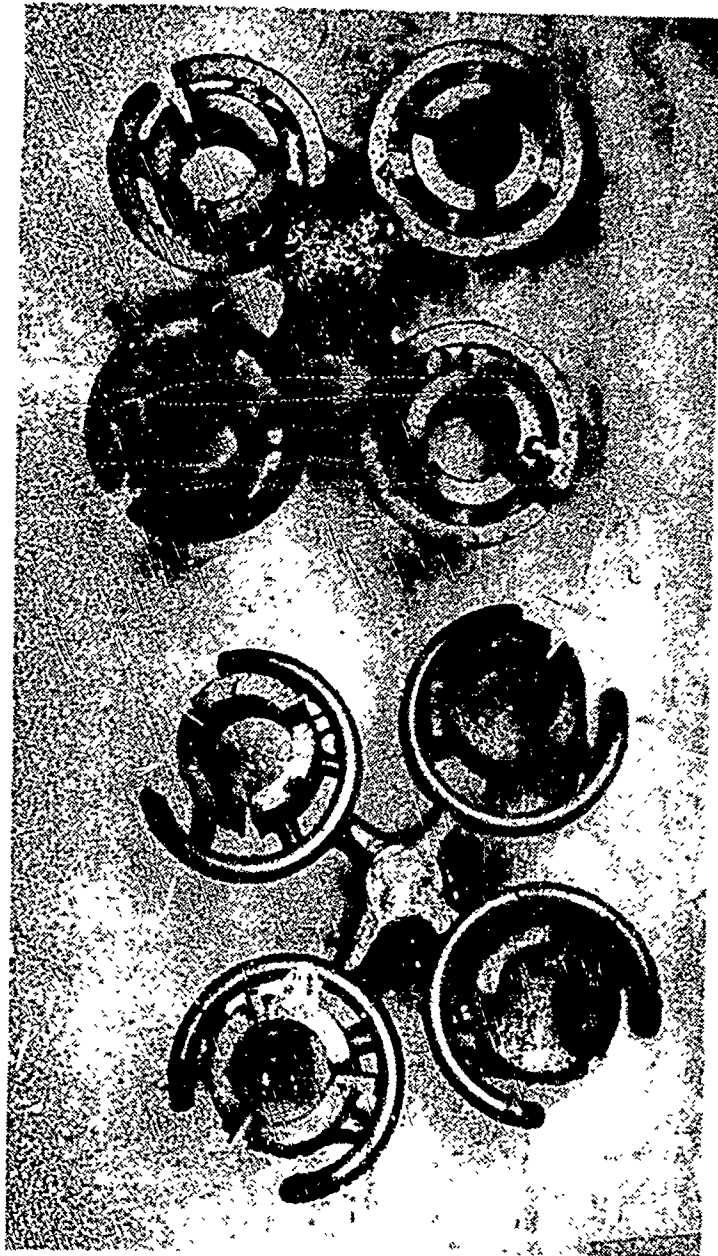

Fig. 8 Detalhes do ensaio com a caixa da figura 6

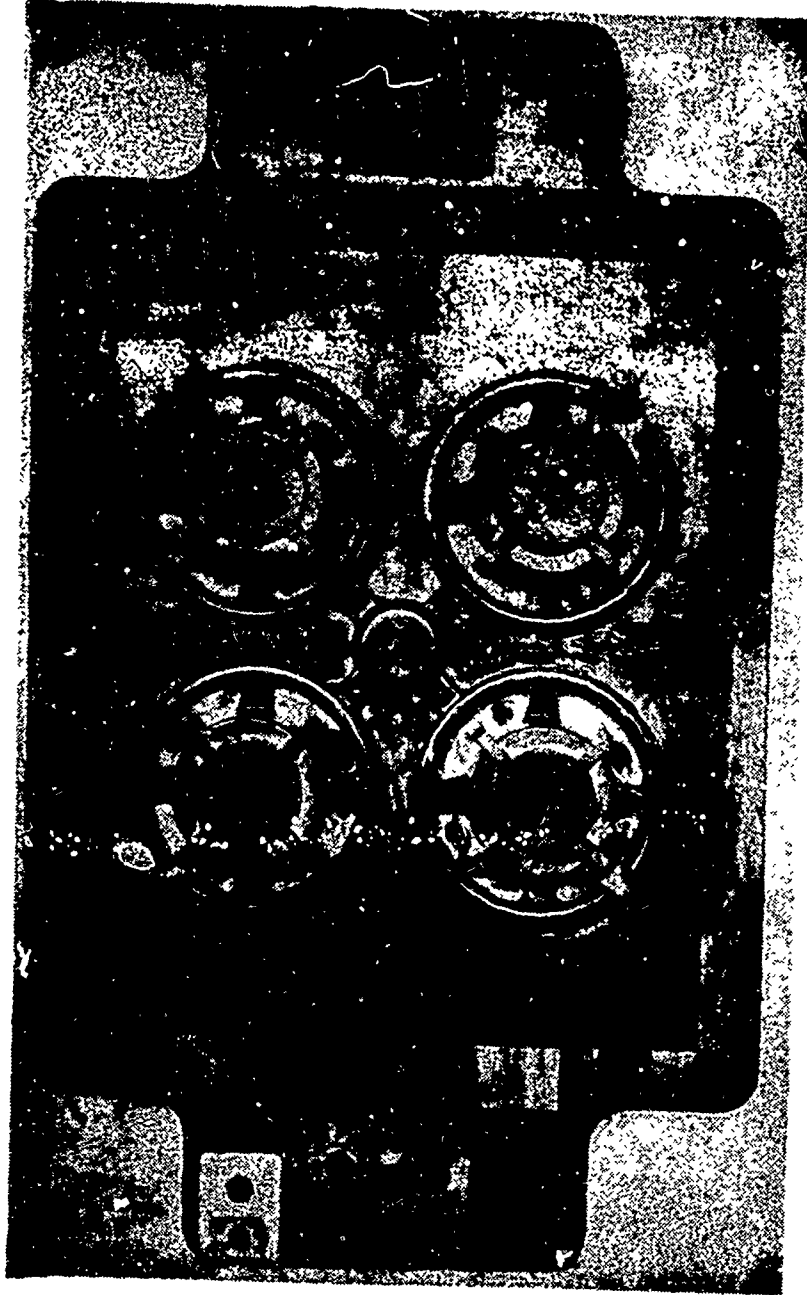

Fig. 9 Ultimo Tipo de Placa utilizada para o preparo de caixas

## SOME ASPECTS OF METAL PROCESSING

---

by Erich G. Thomsen

### Abstract

In a period of rapid advancement of science proficiency can no longer be achieved in any field of endeavor solely through practical experience. This is especially true in metal processing where it is necessary to apply advanced knowledge to the understanding of the behavior of metals in order to select the most suitable and the most economic process and material for a given industrial application.

A short review of the principles of plastic deformation is given and it is shown that forming characteristics and forming limits depend primarily on the state of stress. Accordingly, a classification of the major forming processes based on this concept is presented. In addition several methods of obtaining approximate solutions to forming pressures in forming problems are discussed and a comparison for an upsetting problem is given.

It is shown further that a treatment of forming problems is not complete unless a careful examination of the energy equation is made and every term of the equation properly accounted for. This ensures that no major errors are introduced when making energy balances.

Finally it is suggested that in practice the prediction of forces and energy alone is not sufficient and more thought must be given to the possibility of predicting among others, mechanical properties, surface finish, forming defects. It is

suggested therefore that more research be directed toward model studies in which all of the important parameters in forming and cutting processes can be evaluated. Once such information is available, the possibility exists that a mathematical model can be found which accurately describes the metal-processing operations.

## 1. Introduction

Success in manufacturing under present day economic competition requires exploitation of the most recent advances in the technology of metal processing. The advances in this field are numerous and the application to practice will often result in the modification of an existing process, its reduction in demand, or even its complete elimination. A few of the newer processes which have been accepted in production or are under consideration for application in practice are: continuous casting of steel slabs immediately followed by rolling, laser and electron beam welding, magnetic and explosive forming, spin forging, hydrostatic extruding, piercing and blanking yielding smoothly sheared edges, electrolytic and spark erosion machining, chemical milling, ultrasonic vibration-assisted cutting and forming.

During the time when innovations in manufacturing were few and when processes remained the same for long periods of time, it was possible to obtain the necessary "know how" for production through long years of experience. For example, the open-hearth process in steel-making remained essentially the same for nearly a century lasting until just a few years ago when liquid oxygen was introduced to speed up the refining process. Similarly the conventional metal-cutting process, except for increases in cutting speeds as better tool materials became available and better machine tools were built, remained essentially the same for almost as many years. Our rapidly advancing knowledge in science and technology, however, has changed all this and new ideas and new processes are constantly going into production over much shorter periods of time. Consequently, there is no longer the possibility to gain the necessary "know how" through long experience or by an uneconomical trial and error method. On the contrary, we must try to understand the underlying principles of a new idea or of a new process in order to predict performance with the aid of perhaps only a few critical experiments.

We will give a short account in this paper of the mechanism of plastic deformation and the important role that stresses play in forming operations. We will classify forming operations logically on the basis of stresses and will illustrate the type of solutions available. We will point out further a certain danger that looms ahead unless we treat forming operations as systems and attempt to account



for the expenditure of all energies.

## 2. Rules for Plastic Deformation

It is a well-known fact that metals at low deformation rates (or strain rates) will deform at first elastically following Hooke's law. As deformation continues a critical stress will be reached where plastic deformation is initiated. This stress is called the yield point or yield strength depending on whether the point is well defined or occurs over a small region of straining. This critical stress is also often simply referred to as the yield stress. The yield stress is readily obtainable from a compression or a tensile test for the condition of uniaxial loading when the material remains reasonably isotropic. In the event the forming load occurs in the presence of multiaxial stresses then the yield stress or yield condition is generally accepted to be the effective stress  $\bar{\sigma}$ . This stress is also called the "von Mises yield condition" named for the mathematician von Mises who demonstrated its existence. It applies well to isotropic ductile metals encountered in forming problems, but not to brittle materials. For brittle materials the "Tresca maximum shear stress criterion" generally gives slightly better results.

The effective stress for a general combined state of stress is given by the square root of the sum of the squares of the three shear stresses, which act on the faces of an elemental cube, and the sum of the squares of the resultant shear stresses on the diagonal surfaces of the cube, which are due to the normal stresses acting on the faces of the cube. A general state of stress is shown in Figure 1. Thus, the effective stress (also known as a stress invariant) is essentially the root mean square shearing stress which takes on a critical value when plastic deformation is initiated. Thus the importance of the state of stress in yielding becomes at once evident. It reduces to the yield stress in tension or compression and can be evaluated readily from these tests under static conditions. Under dynamic conditions, or at temperatures other than atmospheric, its magnitude will not be constant and it will depend on the strain rate, metallurgical structure, and temperature. The behavior of the yield stress has been studied from a solid-state physics point of view, where the model is the imperfect crystal, characterized by dislocations. There are also some experimental data for some regions of stressing mainly during high temperature creep and in some scattered tests on impact loading. The available data, however, are incomplete and much more experimental work is required to give the forming engineer the necessary tools for analysis and for prediction of forming results.

After the yield condition has been exceeded the metal will deform plastically in accordance with the rules of plastic deformation. If the metal is cold worked, it will become stronger because of the effects known as work-hardening. The equations relating the stresses to the plastic strains under these conditions are known as the plasticity equations. These equations are useful in calculating strains from the stresses, or vice versa provided the stress or strain path is known. During plastic deformation, the density of the material remains essentially constant, from which it follows that the sum of the finite normal strains is zero.

The resulting plastic deformation is irreversible and appears as heat energy. In the event the deformation is discontinued or it is completed, only the elastic energy is recovered. This is due to the fact that the plastic energy is irreversible and essentially, all will have been converted into heat. The elastic strains associated with the accompanying plastic strains are small and usually can be ignored when compared with the much larger plastic strains. They cannot be neglected, however, when both strains are of the same order of magnitude. Also, the elastic strains can not be ignored when the straining during the deformation process was heterogeneous, because residual stresses will remain in the formed part. These residual stresses may be undesirable as illustrated by the springback of formed flanges during unloading.

### 3. Classification of Forming Processes

From what has been said, it is clear that the forming stresses play an important part in forming problems. It would seem logical, therefore, to use the average state of stress as a criterion for classifying forming operations. Such a classification is given in Figure 2.

An inspection of Figure 2 reveals that the state of stress for large deformations is generally of a compressive nature. The processes carried out under these stresses are classified as squeezing operations and normally are used when a heavy reduction or change in shape is required as in rolling. The extent of deformation under these conditions can be very large because internal cracks, gas cavities, and pin hole porosity are repaired under the influence of compressive loading. One defect which limits the squeezing type of deformation is that of buckling, which occurs in upsetting operations when the workpiece is inadequately supported.

In the drawing group one or more of the forming stresses may have changed to tensile stresses. These forming operations are generally limited in the extent of deformation which may be achieved, because cracks and other defects may open

up rather than be healed and the process may be limited by fracture. In addition, in simple or combined tensile type of loading, the load condition may lead to a type of failure called necking. This failure is typical in a tension test of a ductile material and occurs at the maximum load. It is because the rate of reduction in area exceeds the rate of increase in strength due to work-hardening. Thus the weakest section, which reaches the maximum load first will start necking and will decrease in cross section more rapidly than any other. This type of failure is found also in stretching operations, bulging, stretch flanging, tube expanding, and others. It severely limits the extent of deformation possible.

The bending group of forming operations is principally concerned with the change in shape rather than reduction in cross section. The extent of deformation is much less than that in the squeezing group. The applied load is a moment and the stresses across the section of the workpiece vary from compression on the inner side of the bend radius to tension on the outer side. Thus, bending occurs, in the presence of stress gradients, which lead to residual stresses and to spring-back upon unloading.

The cutting group of metal-working processes can be divided into (a) processes where separation by shearing in a single cut take place as on a press brake and (b) where excess metal is removed by peeling a chip from the workpiece as in metal cutting. Both processes require plastic deformation in the cutting zone. It is important to note that in most forming processes the metallurgical structure of the workpiece is refined due to the plastic deformation process. This is not the case in machining where only the waste material is severely deformed, while the part being machined remains essentially unaffected.

#### 4. Some Methods of Solution to Forming Problems

The subject of determining forming loads and average forming pressures has been a favorite with investigators working in the fields of applied mathematics and engineering mechanics. Due to this effort, much is now known about solutions to forming problems and it is possible to obtain approximate forming pressures. Except for simple problems, however, general methods of obtaining exact solutions are not available. Consequently, an approximate theoretical solution still must be checked with experimental data to assure complete confidence. The reason rests with the assumptions required in the analysis, the effects of which cannot always be predicted. It is seen from Figure 2 that the state of stress in the metal under deformation is an important factor for classification. The state of stress is also important in the evaluation of the forming energy as will be shown subsequently.

The important methods of solution are (a) the Siebel uniform-energy method, (b) the Sachs slab method, (c) the Hencky slip-line method, (d) the Johnson-Kudo-Kobayashi upper-bound method, and (e) the Thomsen viscoplasticity method. The solutions obtained with the methods a-d are compared in Figure 3 for a slab under compression in which the width remains constant (plane strain). Of the solutions the uniform energy method is the simplest and usually gives a value of forming load which is low because of neglect of shear deformation.

The average pressure is given by  $p_{ave} = \int_0^{\bar{\epsilon}} \bar{\sigma} d\bar{\epsilon}$ , where the definite integral is the energy per unit volume of the material deformed and is simply the area under the tensile or compressive stress-strain curve at an identical effective strain  $\bar{\epsilon}$ . The magnitude of  $p_{ave}$  is usually low since  $\bar{\epsilon}$  cannot be determined exactly in an arbitrary forming problem since shearing strains are not known. A better value of  $p_{ave}$  is obtained if friction is also taken into account and if a shear coefficient is used to compensate for the neglect of shear deformation. For the upsetting problem shown in row (a) of Figure 3, experiments have shown that neglect of shear deformation is not serious for this problem and the value of  $p_{ave}/\bar{\sigma} = 3.1$  is a realistic value for maximum friction and for a condition when  $l_f/h = 6.72$ . Thus,  $p_{ave}/\bar{\sigma} = 3.1$  where  $\bar{\sigma}$  is the effective yield stress which must be taken as an average value.

The slab method is shown in (b) of Figure 3, which involves the integration of a linear differential equation and relates the stress gradient in the width direction  $x$  to the variable height  $h$  for the maximum condition of friction. The plasticity and yield conditions furnish the required interrelation between these variables. The solution is seen to be identical to that obtained with the uniform-energy method.

The slip-line solution for the same problem is shown in (c) of Figure 3. The figure to the right shows lines which indicate the maximum shear directions. These lines are drawn to satisfy the static stress-equilibrium equations for the given boundary conditions as well as for the velocity distribution of the metal. The equations shown on the left of the sketch permit the determination of the pressure distribution from which  $p_{ave}$  can be calculated. It is seen that the magnitude of  $p_{ave}/\bar{\sigma} = 2.83$ , is somewhat below the other two solutions.

The upper-bound solution is shown in (d) of Figure 3. This method consists of dividing the plastic region into small triangles as shown in the figure. In each of these triangles, the metal is assumed to flow as a rigid body and all plastic deformation occurs along the diagonals and along the die surfaces. The problem consists of determining the shear-strain rates along these lines and summing up all energies to obtain the total minimum energy required for deformation. It is seen that the value of  $p_{ave}/\bar{\sigma} = 2.9$  lies between those of (a) or (b) and (d) of Fig. 3. It should be remarked that the agreement among these solutions is not always as close as in the foregoing example and only a comparison with results from an ex-

pe

mi  
anc  
equ  
for  
vel  
dis  
uti  
stethe  
whi  
ing  
ma

5.

pro  
gas  
fro  
all  
ati  
andin  
equ  
anc  
ofat  
exa  
in  
thr  
for

periment can furnish the basis for making the selection of the best solution.

Finally, viscoplasticity is a method in which the metal flow field is determined from an experiment. This flow field is then used to calculate strain rates and the internal stresses. It utilizes the plasticity equations, the equilibrium equations and the stress-strain or strain-rate equations in analytical or graphical form. Figure 4 shows deformed grid lines of an aluminum extrusion. The particle velocities can be obtained by deforming the metal in small steps and noting the displacements of the grid-line intersections. The resulting axial-stress distribution is shown in Figure 5 obtained under the assumption that the flow was in steady-state.

The selection of the "best solution" for any given problem will depend on the resourcefulness of the engineer and his prime task is the choice of that method which appears to be most likely to give a useful answer. The engineer must be ingenious and the choice of the method and interpretation of the results must be made shrewdly.

## 5. The Energy Equation

In the foregoing metal-working operations have been considered as isolated processes, much as one would consider a compression or expansion process of a gas in heat engines. Actually, however, metal-working operations are not isolated from their surroundings and one ought to consider systems in their entirety with all materials and energies entering and leaving accounted for. Such a consideration leads to the energy equation, which is in fact an energy-accounting equation and assures that no important quantities have been neglected.

While it is common practice to use the energy equation for a flow system in problems of thermodynamics, fluid flow, and heat transfer as the starting equation, metal-processing and production engineers often overlook its importance. However, its significance is at once apparent when the relative importance of each term in the equation is considered.

Let Figure 6 represent a metal-shaping device in which metal is flowing in at the bottom and leaves in a transformed state at the top. The shaping device, for example, may be a drawing die where the metal is continuously pulled through as in wire or bar drawing, it may be an extrusion apparatus where the metal is pushed through a die or it may be a metal-cutting zone in machining. The exact process for the present argument is unimportant, but let the dotted lines 1 and 2 represent

the boundaries between which the shaping process takes place. It is assumed that metal can enter and leave via sections 1 and 2 only, but the energy may flow across the boundaries of the device. Then an energy balance may be written for the condition of steady state flow,

$$J (h_2 - h_1) + (v_2^2 - v_1^2)/2g + (z_2 - z_1) - JQ - E = 0, \quad (1)$$

where in the foot-lb. system for each pound of material flowing,

- $h$  = enthalpy or heat content, Btu per pound of material
- $v$  = velocity, ft/sec
- $z$  = position of section, ft
- $Q$  = heat flow into system Btu/lb
- $E$  = mechanical, chemical, or electrical work done on system ft. lbs./lb
- $J$  = mechanical equivalent of heat (1 Btu = 778.28 ft. lbs.)

The several terms in the energy equation do not necessarily have the same significance in all metal-shaping processes of industrial importance.

The potential energy by virtue of position ( $z_2 - z_1$ ) can usually be neglected. Also, the kinetic energy term  $(v_2^2 - v_1^2)/2g$  can often be ignored, since this energy is usually small when compared with the electrical or mechanical energy required to carry out a forming process. In an electrolytic machining process shown schematically in Figure 7, the work material is shaped by removing the excess material by electrolysis. This requires normally the discharge of a substantial dc current through a narrow gap between the negative tool (cathode) and the positive workpiece (anode). The electrolyte is alkaline and may be a dilute solution of common table salt ( $\text{NaCl}$  in  $\text{H}_2\text{O}$ ), modified with an inhibitor to prevent corrosion. It is pumped continuously through the gap to carry off the heat and the reaction products. Thus for the electrolysis, Equation 1 reduces to

$$J (h_2 - h_1) - JQ = E$$

$$\text{or} \quad J (h) - JQ = E, \quad (2)$$

where the energy  $E$  must be sufficient to account for the heat flow  $-Q$  out of the system and the formation energy of the reaction products  $\Delta h$  required for the electrolysis. The current flow can be computed by making use of Faraday's law which states that one gram equivalent weight of metal is altered at each electrode for each 96500 coulombs (1 coulomb = 1 ampere per second). In the electrolysis hydrogen is liberated at the tool surface while excess metal is removed from the work surface. Thus, the process in essence is a deplating process, and the reactions in the narrow gap between the tool and workpiece due to the presence of ions in the solution and the passage of a strong current are as follows:

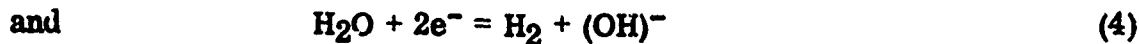
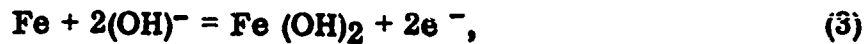

The reaction (3) occurs at the anode and liberates iron which first forms the insoluble compound  $\text{Fe}(\text{OH})_2$ , but later in contact with air is oxidized to  $\text{Fe}(\text{OH})_3$  and can be filtered out, while reaction (4) liberates  $\text{H}_2$  at the cathode. The tool is not affected by the reaction and for each atom of iron removed two electrons ( $2e^-$ ) must be supplied from an outside agency.

In order to calculate the enthalpy change in the system it is necessary to consider the heat of formation of the products in the reaction. Writing the complete reaction of Equations (3) and (4) results in



for which by substitution of the heats of formation at the standard temperature of  $18^\circ\text{C}$  and 1 atm. pressure results in the equation

$$2 \times 68 + 0 = 2(-50) + 136 + \Delta H. \quad (6)$$

Thus the formation of the reaction products results in the net energy absorption of

$$\Delta H = 100 \text{ kilocalories,}$$

or

$$\Delta H = 100 \times 3.97 = 397 \text{ Btu/gram mol of iron} \quad (7)$$

This heat is absorbed in the formation of hydrogen gas and  $\Delta H$  can be used to calculate  $\Delta h$  per lb. of iron removed from the workpiece, namely

$$\Delta h = \frac{w}{\text{mol (Fe)}} \Delta H = \frac{454}{55.84} \times 397 = 3130 \text{ Btu/lb.} \quad (8)$$

where  $w = 454$  grams per pound of iron and one  $\text{mol}(\text{Fe}) = 55.84$  grams is the molecular weight of iron.

The electrical energy  $E$  can be calculated from the required current for the electrolytic reaction and the voltage drop across the gap between the electrodes. The number of coulombs of electricity is obtained from Faraday's law, where the gram equivalent weight of iron is given by  $\text{mol}(\text{Fe})/2e^- = 55.84/2 = 27.42$  grams. Hence the electricity requirement in coulombs for each gram of Fe liberated is given by

$$\frac{96,500}{27.42} = 3510 \text{ coulombs/gram Fe} \quad (9)$$

Assuming that the removal rate is one pound of iron per minute, then the current requirement from Equation (9) is given by

$$i = 3510 \times \frac{454}{60} = 26,800 \text{ amperes} \quad (10)$$

Assuming further that the voltage drop between the electrodes is 10 volts according to observations in practice, then the power requirement would be

$$E = iV = \frac{26,800 \times 10}{100} = 268 \text{ kilowatts} \quad (11)$$

The heat removal rate (-Q) in Btu per minute from the electrolyte by refrigeration can now be calculated from Equation (2)

$$-JQ = E - J(\Delta H)$$

$$\text{or} \quad -Q = 268 \times 56.9 - 3130 = 12100 \text{ Btu/min,} \quad (12)$$

where 56.9 is the conversion factor from kilowatts to Btu per min. of heat flow. It is seen that in this process the energies are enormous and the current flow and the refrigeration rates (approximately 60 tons of refrigeration) are large. Commercial electrolytic machining units of about one third of the capacity of electrical energy are in practical use, but there is reason to believe that units as large or larger than the one discussed are feasible.

Consider next the application of the energy equation to a metalcutting problem. For simplicity a two-dimensional cutting process (orthogonal cutting) is considered as shown in Figure 8. The main energy for cutting is consumed in the region (a), where plastic deformation by shear takes place in a narrow zone. Additional energy consumption occurs at (b) through friction between the chip and tool face and to a smaller extent at (c) by friction between the flank of the tool and the machined surface. If one assumes that the cutting velocities are in the practical range, then the potential and kinetic energy terms of Equation (1) may again be neglected when compared with the plastic flow and friction energy terms, and the mechanical energy rate  $E'$  is given by

$$E' = F_c V \quad (13)$$

Thus the energy balance gives the equation

$$w'J [-Q + w c_p (T_2 - T_0)] = F_c V, \quad (14)$$

where:



- $w'$  = lbs. of metal removed in the form of the chip, lbs/sec.  
 $c_p$  = specific heat at constant pressure, Btu/lb. deg. F  
 $T_2$  = final average chip temperature, deg. F  
 $T_0$  = initial workpiece temperature, deg. F  
 $F_c$  = cutting force in the direction of motion, lbs  
 $V$  = cutting velocity, ft/sec  
 $-Q$  = rate of heat flow out of the cutting region into the tool, the workpiece, and the surroundings, Btu for  $w'$  lbs

If the cutting process is carried out at higher speeds, say 300 ft/min or more, then the process approaches adiabatic conditions and the heat flow  $-Q$  to the surroundings is nearly zero. Thus, we may write

$$Jw'c_p(T_2 - T_0) = F_c V \quad (15)$$

and all energy will leave with the chip as internal energy. Thus, equation (15) permits the determination of  $F_c$ , when  $T_0$ ,  $c_p$  and the rate of metal removal  $w'$  are known. Also the forces in forming as well as in cutting may then be calculated from the energy required for plastic deformation and friction.

While it was possible to neglect the kinetic energy term in the foregoing examples, this is not always justified. A case in point would be ultra-high speed cutting at, say, 100,000 ft./min. This velocity was achieved on an experimental basis by letting a projectile graze a stationary cutting tool, where the projectile was the moving workpiece. It was found in these experimental cutting tests that the chips were formed in continuous ribbons in a manner similar to conventional cutting. However, while chip formation may be similar, energies are not, and the kinetic energy term of Equation (1) can no longer be ignored, since the chip must be deflected at high speed by the tool in a direction parallel with the tool face. Table I shows calculated force and energy values for several cutting speeds and it is evident that the dynamic character of the process takes on major significance.

Table I

Effect of Cutting Speed on Energy Absorption  
of SAE 1112 Steel Orthogonal cut

rake angle,  $\alpha = 0^\circ$

undeformed chip thickness,  $t_0 = 0.008$  ips

depth of cut,  $w_0 = 0.20$  in

cutting ratio,  $r_c = 0.47$

cutting speed ft/min.	Mechanical Energy ft. lb./lb	Kinetic Energy ft. lb./lb	Total Energy ft. lb./lb
$10^2$	-56,300	-0.03	-56,300
$10^3$	-56,300	-3.3	-56,303
$10^4$	-57,300	-336	-57,636
$10^5$	-142,500	-33600	-176,100

### Conclusions

From the foregoing discussion it is evident that substantial progress has been made in understanding the mechanics of plastic deformation in forming processes and in utilizing this knowledge for the purpose of determining energies and forming loads. However, while the knowledge of forming loads and energies has theoretical importance, it may not have the same importance in practice. Among the problems that remain are: the determination of (a) structural change in the metal during deformation, state of work-hardening and strain, (b) damage imposed by forming through the formation of microcracks, (c) limits of forming imposed by necking, buckling, and fracturing, (d) effect of hydrostatic pressure and high strain rate on flow and forming limits, (e) mechanism of friction under conditions found in metal forming, (f) stress-strain rate-temperature relationships for common metals and range of conditions used in practice, (g) surface quality and surface finish.

Some information is available but it is spotty and it is incomplete. Necking for example, has been studied and predictions have been proposed for which experimental evidence is lacking, especially for combined stresses and high-rate

forming. Buckling has been investigated and equations are available for prediction but little or no experimental evidence is available. Fracturing, also, has been under study for many years, but only brittle fracture is reasonably well understood, whereas our knowledge of ductile fracture of metals is incomplete. In addition it has been shown that yielding and flow do not seem to be influenced by hydrostatic pressure, but it is not known what effect this pressure has on fracture and on other forming limits.

It appears that many of these unsolved forming problems are not amenable to analysis alone and that more experimental data are needed. However, unless the experiments are chosen in such a way that generalization is possible, the results will have only limited application. Careful planning of experiments will be an essential ingredient to success. The author believes that wider use should be made of model studies in order to gain a better insight into actual deformation processes in aiding in the determination of texture, strain, residual stresses, surface finish and other important properties of the finished workpiece.

In conclusion it should be said that an important consideration in metal-working problems in the future would be to take into account not only forces and energies required in forming operations but to explore the interaction between the final shape and properties of the formed part, and the material and its structure, its initial shape, the tools, the forming machines and the deformation processes. Hence, the model for a forming process besides energies should include such items as are shown in Figure 9, which should let us better describe all important properties of the material before and after forming.

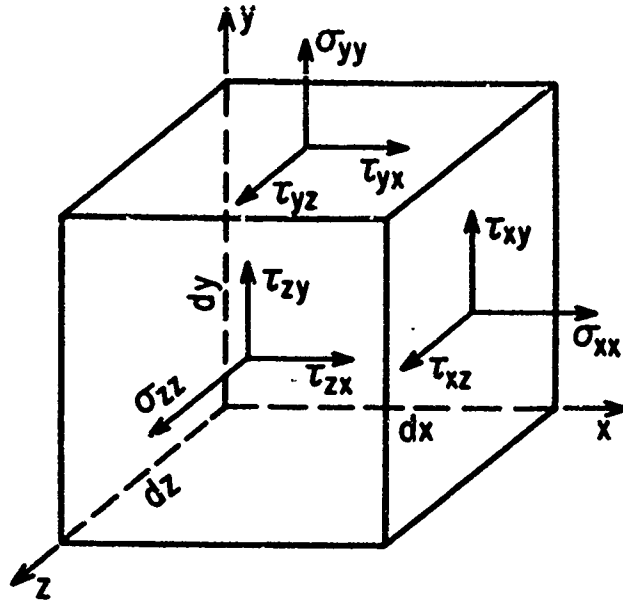

Fig. 1 State of Stress at a Point

BASIC DEFORMATION MECHANISM	SKETCH OF OPERATION	STATE OF STRESS (AT SOLID SQUARE/IN. SKETCH)	NAME	BASIC DEFORMATION MECHANISM	SKETCH OF OPERATION	STATE OF STRESS (AT SOLID SQUARE/IN. SKETCH)	NAME
SQUEEZING			CLOSED DIE FORGING	SQUEEZING			EXTRUDING (BACKWARD)
SQUEEZING			COINING	SQUEEZING			EXTRUDING OF CAN (BACKWARD)
SQUEEZING			UPSETTING (OPEN DIES)	SQUEEZING			ROLLING
SQUEEZING			UPSETTING (CLOSED DIES)	SQUEEZING			SPIN FORGING OF TUBES (FORWARD)
SQUEEZING			EXTRUDING (FORWARD)	SQUEEZING			SPIN FORGING OF TUBES (BACKWARD)

Fig. 2 Some Metal-Forming Operations

BASIC DEFORMATION MECHANISM	SKETCH OF OPERATION	STATE OF STRESS (AT SOLID SQUARE/IN. SKETCH)	NAME	BASIC DEFORMATION MECHANISM	SKETCH OF OPERATION	STATE OF STRESS (AT SOLID SQUARE/IN. SKETCH)	NAME
SQUEEZING			SPIN FORGING OF CONES	BENDING			STRETCH FLANGING
SQUEEZING			SWAGING	BENDING			SHRINK FLANGING
DRAWING			BAR AND WIRE DRAWING	BENDING			SEAMING
DRAWING			TUBE DRAWING	CUTTING (CHIPLESS)			PRESS SHEARING AND CUTTING OFF
DRAWING			DEEP DRAWING	CUTTING (CHIPLESS)			NOTCHING AND NIBBLING
DRAWING			EMBOSSING	CUTTING (CHIPLESS)			PIERCING AND BLANKING
DRAWING			STRETCH FORMING	CUTTING (CHIP FORMING)			SHAVING
DRAWING			BULGING	CUTTING (CHIP FORMING)			MACHINING (SINGLE AND MULTI POINT TOOLS)
DRAWING			ROLL FORMING	CUTTING (CHIP FORMING)			GRINDING
BENDING			STRAIGHT FLANGING				

Fig. 2 (Cont.)

PLANE STRAIN  
 $l_f/h = 0.72$ ; PERFECTLY ROUGH DIES



a. UNIFORM-ENERGY METHOD

$$\frac{P_{ext}}{\sigma} = \sqrt{3} \left( 1 + \frac{1}{4} \frac{l_f}{h} \right) = 3.1$$

b. SLAB METHOD



$$\frac{P_{ext}}{\sigma} = \sqrt{3} \left( 1 + \frac{1}{4} \frac{l_f}{h} \right) = 3.1$$

c. SLIP-LINE METHOD

$$\left. \begin{aligned} \sigma_x &= -p - k \sin 2\phi \\ \sigma_y &= -p + k \sin 2\phi \\ \tau_{xy} &= k \cos 2\phi \end{aligned} \right\} \frac{P_{ext}}{\sigma} = 2.83$$

$k = \sigma/\sqrt{3}$



d. UPPER-BOUND METHOD

$$\frac{P_{ext}}{\sigma} = \sqrt{3} \left[ \left( m - \frac{1}{2} \right) \frac{h}{l_f} + \left( \frac{m+1}{4m-1} \right) \frac{l_f}{h} \right]$$

$= 2.9 \quad (m=3)$



Fig. 3 Some Methods of Solution Applied to an Upsetting Problem

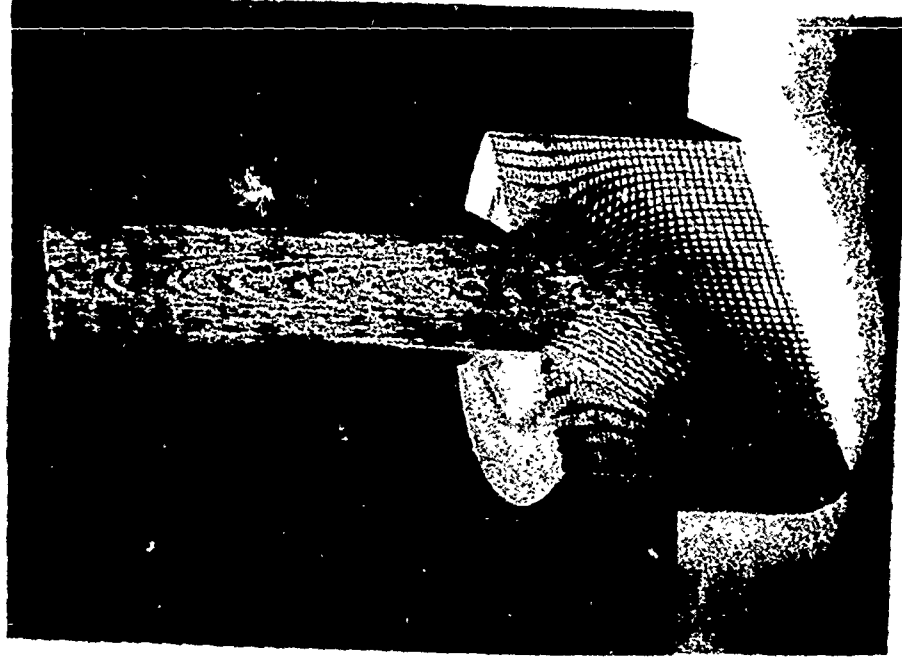

Fig. 4 Deformed Grid Lines in an Extrusion

Fig. 1-17

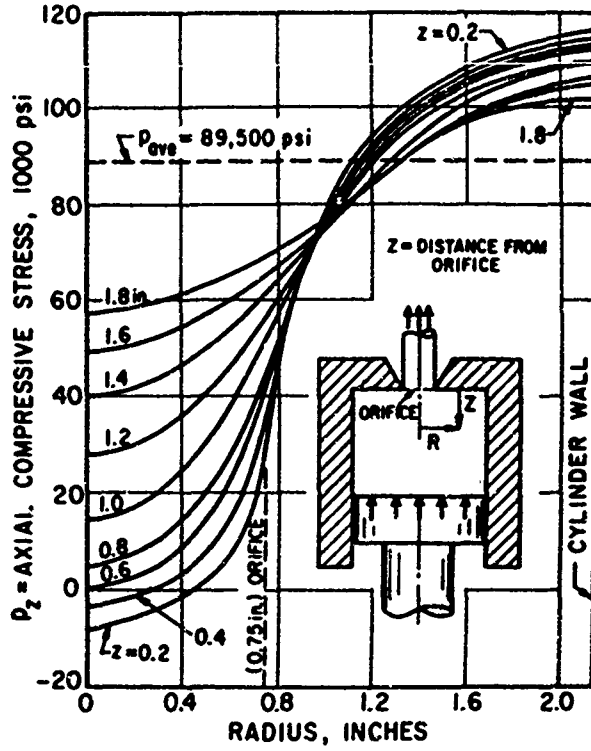

Fig. 5 Axial Stress Distribution in a 4.3 in. Diameter Aluminum Billet Extruded into a 1.5 in. Dia. Rod.

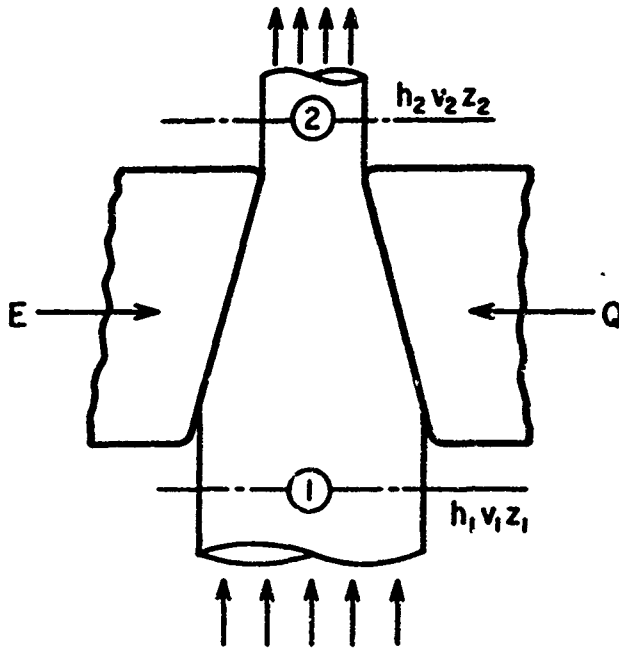

Fig. 6 Schematic Diagram of Metal Shaping Device

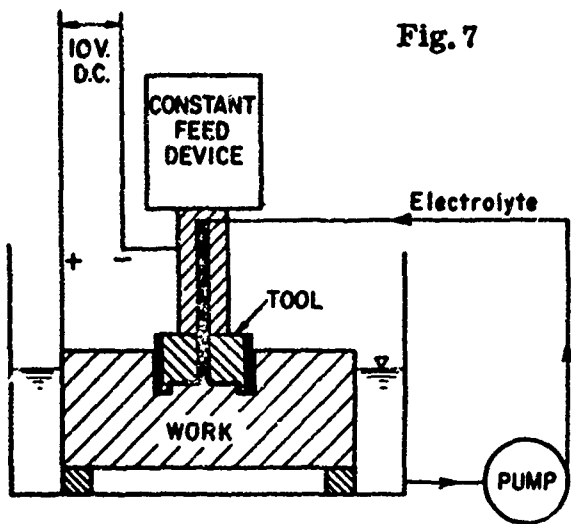

Fig. 7 Schematic Diagram of an Electrolytic Machining Process

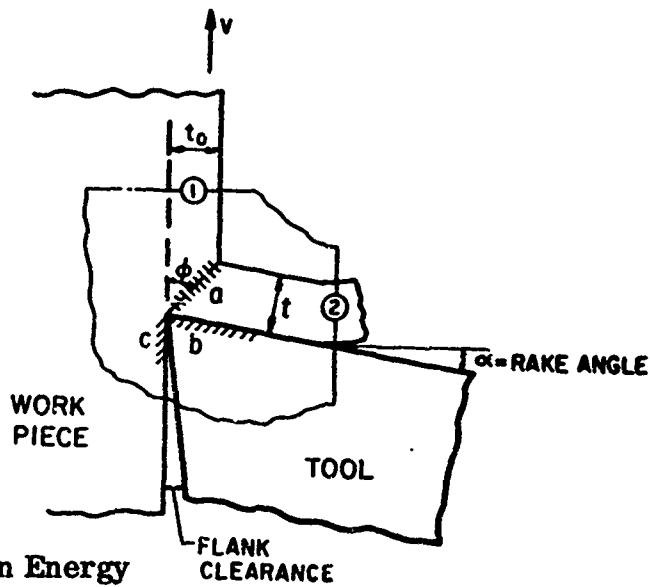
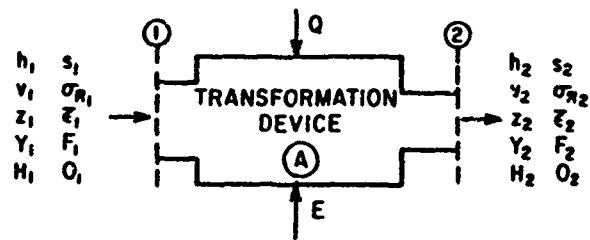

Fig. 8 Metal Cutting Zone as an Energy Transformation Device



$h$  = enthalpy  
 $v$  = velocity  
 $z$  = elevation  
 $s$  = structure  
 $\sigma_R$  = residual stress  
 $\bar{\epsilon}$  = finite strain  
 $F$  = surface finish and lay  
 $Y$  = yield strength  
 $H$  = hardness  
 $O$  = orientation of defects (Mech. fibering)  
 [at (A), complete information on process is required]

Fig. 9 Modified Sketch of Energy Transformation Device Showing Additional Information of Vital Interest in Forming Problems



TRI-SERVICE COORDINATED METAL WORKING AND PROCESSING PROGRAM

---

by Norman L. Reed

Introduction

Land, sea, and air are the natural divisions of the earth on which we live. The responsibilities of the United States Army, Navy, and Air Force are mainly parallel to these three natural states. The three services work together in an endeavor to maintain a national posture. In like manner, researchers, scientists, and engineers work together in the metals working and processing program to translate research knowledge into useful engineering and structural metals.

Having recognized the need to be ever moving forward to meet the requirements placed on our Army agencies and to minimize the time interval between research knowledge and the final production or manufacture of useful "hardware", it is evident that concerted effort is justified to improve old and invent new ways of handling and processing metals into usable shapes with optimum properties under quality-controlled conditions.

In general, industry currently produces heavy tonnages of the usual engineering metals to rather rigid requirements and these metals are, in turn, shaped, joined, and fabricated into the thousands of items used daily in our homes, factories, schools, automobiles, etc. The endeavor of the Army, working in close cooperation with the Navy and Air Force, is to develop methods of converting the unusual and costly metals into closely controlled shapes, sizes, and contours while avoiding excessive loss or waste of these metals as they become functional parts of a system.

Although quality control or process control is not a part of this program per se, it is expected that the working and fabrication of the unusual metals or unique shapes of the more standard metals will reveal that new quality control

techniques will be required. The research and development teams working on the program being reported here, having developed new processing techniques, will be of great assistance to those responsible for developing quality assurance techniques.

Additional background relative to the establishment of the coordinated metal working and processing program included an assignment by the Department of Defense to the Materials Advisory Board of the National Academy of Sciences to make an exploratory investigation on the topic of deformation of metals. An ad hoc committee was formed for this purpose. Although the committee has been dissolved, its deliberations interested many segments of the Department of Defense and in part instigated the holding of a research conference in August 1962\*, on "Fundamentals of Deformation Processing", which was sponsored by the U. S. Army Materials Research Agency (AMRA) in conjunction with Syracuse University under the chairmanship of the author of this paper. This conference, attended by carefully selected talent, did much to solidify the known information of the universities, industry and Government on this subject.

#### Participating organizations

Under the authority of the Department of Defense, the Army, Navy, and Air force joined in the establishment of the current Metalworking Processes and Equipment Program (MPEP) in the latter part of 1962. The National Aeronautics and Space Administration was also interested and joined the endeavor. The Navy was assigned the responsibility of coordinating the program and Mr. Thomas F. Kearns was named Chairman of the Government Steering Group of the MPEP. The above three services and NASA have membership in this group, in addition to other representation from the Department of Defense and the Defense Metals Information Center. This group meets approximately three times a year and deliberately chooses to assemble at locations where considerable activity in metal working is taking place.

Following the frequent custom of the Department of Defense to assure as broad as possible advice on a particular subject, the Department requested the National Academy of Sciences to establish a Metalworking Processes and Equipment Committee under its Materials Advisory Board (not ad hoc committee, as

---

\*Under a contractual agreement, the proceedings of this conference have been published by Syracuse University Press in a book bearing the same title.

previously reported). Members of this committee are currently drawn from four universities, from four prominent companies in industry, and from two research institutes or laboratories. It convenes under the chairmanship of Dr. William Rostoker of the Research Institute of Illinois Institute of Technology.

#### Purpose of the program

The program is designed to fulfill a continuing need to assess research information on metal deformation, devise and promote improved metal processing equipment, and recommend processing conditions that will yield optimum characteristics in the variety of metals required by the Department of Defense, some of which are frequently difficult to process. Three phases of this effort have been recognized. They are:

- a. compilation of existing knowledge of the deformation characteristics imposed by the various processes, \*
- b. recommendation of programs necessary to overcome gaps in the present knowledge, and
- c. design, construction, and operation of new metalworking equipment.

#### Activities under the program

Attention has been focused to a considerable extent on the deformation characteristics of refractory metals, on beryllium, and on super alloys, with initial emphasis on the rolling process. Attention to extrusion, spinning, drawing and the like will be initiated at a later date. Consideration of strain rate, effect of temperature, anisotropy, crystallographic texture, and of ultrasonic energy and high pressure have been included in the program.

---

\*Processing of metals in the solid state includes cold drawing, cold extrusion, rolling, etc.

It has been obvious from the start that dissemination of the results of the program was essential: thus, preparation of reports that would acquaint processing equipment designers and manufacturers with the advances in deformation processing has been included.

A reasonably complete listing of programs in Government laboratories or conducted under contract, either planned, under way, or completed, has been compiled. As an aid in visualizing the program, a list of typical efforts is attached as Appendix A, which notes the sponsors as well as those conducting the research.

Meetings of the Government Steering Group of MPEP have been held at the Bureau of Naval Weapons, at Wright-Patterson Air Force Base, and at AMRA, with opportunity to observe some of the activities associated with the program. There were three presentations made to the Steering Group at the AMRA meeting. These were:

- a. Thermomechanical Treatment of Steel - Dr. E. B. Kula
- b. Metal Behavior in Rolling and Wire Drawing - Mr. E. DiCesare
- c. Development of Anisotropy in Titanium - Mr. F. R. Larson

The Steering Group sponsored a "Symposium on Ultrasonics in Metal Deformation" in June of 1963. The Defense Metals Information Center (DMIC) prepared a report of the symposium, DMIC Report 187, dated 16 August 1963, entitled "The Application of Ultrasonic Energy in the Deformation of Metals". Some excerpts from this are given in Appendix B.

In addition, a second symposium on high pressure in metal-deformation processing was held in October 1963. The DMIC was likewise charged with the responsibility of reporting on this meeting and issued DMIC Report 199, dated 2 March 1964, entitled "The Application of High Pressure in Metal-Deformation Processing". Some excerpts from this report are given in Appendix C.

#### Materials advisory board program

As noted previously at the request of the Department of Defense, the

Materials Advisory Board had established a Metalworking Processes and Equipment Committee composed entirely of non-Government scientists and engineers. This committee, acting under the auspices of the National Academy of Sciences, has been asked to provide advice and assistance to the Department of Defense in the organization and conduct of an integrated program on the advancement of deformation theory and its application to the manufacturing process. The letter of assignment from DOD noted (a) that basic and applied research has resulted in an increase in knowledge of metals deformation phenomena; (b) an interservice program (MPEP) involving participation of a Government Steering Group has been initiated to reduce this knowledge to practice; (c) that the cooperation of the scientific community and the metal working equipment producers and users would be desirable in MPEP; and (d) that an MAB committee should be organized to promote this cooperation. The ground rules for the MAB committee are as follows: (a) to serve as a forum for discussion of deformation technology among well-informed individuals from industry, academic organizations, and Government; (b) to review and guide Army, Navy, and Air Force programs, both present and proposed; and (c) through the issuance of advisory reports, to make recommendations for initiation or the conduct of research and development in deformation processes.

The first meeting of the MAB committee was held in November of 1963 in Chicago, Illinois. The committee agreed to focus its attention upon the direction and balance of the research and development projects in the early stages of effort and on those projects now being planned. It is also possible that the MAB committee will be asked to review and comment on the specific proposals received by the Services.

For longer range activity the committee suggested that it could concern itself with (a) discussions involving exploration of unexploited areas which might lead to the development of new manufacturing techniques; (b) arranging for trade association and industrial representatives to discuss the obstacles and factors which limit design and operation of present equipment; and (c) investigating the fruitful avenues for displaying the findings of the Government program to a large segment of the engineering community.

This committee recognizes that the disciplines of primary importance to the current program are physical metallurgy, mechanical metallurgy, materials engineering, physics, applied mechanics, and mechanical engineering.

A second meeting of the MAB committee was held in April of 1964. The presentations covered capacities and limitations of present ultrasonic generators and of high-pressure hydrostatic systems as applied to metalworking, a review of some of the effort underway, a review of some proposals received, a discussion on continuum mechanics, a paper on the applicability of flow stress and strain measurement to the analysis of real deformation processes, and a paper on super-

plasticity.

Summary

The Department of Defense has embarked on a research and development program covering the facets of metalworking and processes that now limit our ability to produce, as economically as possible, structural metals (most frequently the highcost uncommon metals) with optimum properties and in optimum shapes. The approach reported is quite typical of those used by the three Services of the Department of Defense to thoroughly coordinate the many facets of a broad program. To date the program is "young". We confidently expect that it will have profound effects on the availability, in quantity, of a variety of metals with shapes and characteristics that are not now attainable. Results of the effort have been and will continue to be reported in the open literature.

APPENDIX A

LISTING OF TYPICAL EFFORTS RELATING TO  
METALWORKING PROCESSES AND EQUIPMENT PROGRAM

Category I. Modes of Deformation

Typical Programs

Flow and Fracture Characteristics of Titanium  
Flow and Fracture Characteristics of Tungsten and Tungsten Alloys  
Flow and Fracture Characteristics of Beryllium  
Tungsten Single Crystals  
Bauschinger Effects  
Fracture in Polycrystalline Tungsten  
Effect of Precipitates in Plastic Flow at Low Temperatures

Typical Sponsors

Army Materials Research Agency  
Navy - Bureau of Weapons  
Air Force - Materials Laboratory

Typical Research Groups

Franklin Institute  
Linde Company  
European Research Associates  
Battelle Memorial Institute  
Cornell Aeronautical Laboratory

**Category II. Strain Rate and Temperature Studies**

**Typical Programs**

**Effect of High Strain Rates on Mode of Deformation and Ductile  
Brittle Fracture Transition**  
**Determination of Shear Forming Parameters for 18%Ni Alloys for  
Gun Tube Production**  
**Warm Working of Armor Steel for Increased Toughness and Strength**  
**Polycrystalline Aggregates in Metal**  
**Dynamic Plastic Deformation in Aluminum Single Crystals**  
**Stress-Strain Characteristics of Materials at High Rates of Strain**  
**Effect of Strain Rate and Temperature on Deformation Character-  
istics of Beryllium, Tungsten, and Udimet 700**  
**Development of Explosive Forming Techniques in Metal Forming**  
**Extrusion, Rolling, Forging of Refractory Metals**  
**Extrudability Parameters for Ingot Extrusion**  
**Deformation and Fracture of Crystalline Solids Under Dynamic  
Loading**  
**Cyclic Strain Accumulation Under Complex Multiaxial Loading**  
**Basic Parameters of Metal Behavior under High Energy Rate Forming**  
**Metal Behavior in Rolling and Wire Drawing**  
**Warm Swaging of Refractory Metals**

**Typical Sponsors**

**Army - Watervliet Arsenal**  
**Army - Tank and Automotive Center**  
**Army Research Office - Durham**  
**Army Materials Research Agency**  
**Navy - Bureau of Weapons**  
**Air Force - Materials Central**  
**Air Force - European Research Office**  
**National Aeronautics and Space Administration**

**Typical Research Groups**

**Army - Watervliet Arsenal**  
**University of California**  
**Southwest Research Institute**  
**University of Texas**  
**Naval Ordnance Test Station**



New England Materials Laboratory  
Central Institute of Industrial Research - Norway  
Westinghouse Electric Corporation  
Wright-Patterson Air Force Base Metals Laboratory  
Convair Division - General Dynamics  
University of Liverpool - England  
University of Illinois  
Rutgers University  
Aerojet General Corporation  
Lewis Research Center - NASA  
Army Materials Research Agency  
Arthur D. Little Company  
Frankford Arsenal

**Category III. High Pressure Effects**

**Typical Programs**

Structural Changes in Anisotropic Materials Under Hydraulic  
Pressure to 40,000 Atmospheres  
Hydrostatic Extrusion of Tungsten and Beryllium Under High Pres-  
sures  
Drawing Sheet Metals Under Hydrostatic Pressure  
Hydrostatic Extrusion of Refractory Metals

**Typical Sponsors**

Army - Watervliet Arsenal  
Navy - Bureau of Weapons  
Air Force - Materials Central  
National Aeronautics and Space Administration

**Typical Research Groups**

Army - Watervliet Arsenal  
Pressure Technology Corporation of America  
General Electric Corporation Research Laboratory  
Battelle Memorial Institute

**Category IV. Ultrasonic Effects**

**Typical Programs**

**Effect of Ultrasonics, Temperature and Strain Rate on Deformation Characteristics of Structural Metals**  
**Effect of Ultrasonics on Deformation Characteristics of Metals**  
**Effects of Ultrasonics on Wire Drawing**  
**Application of Ultrasonics to the Rolling Process**  
**Feasibility of Ultrasonics for Determination of Structural Inhomogeneities and Residual Stress in Various Metal and Non-Metal Structures**

**Typical Sponsors**

**Navy - Bureau of Weapons**  
**Air Force - Materials Laboratory**  
**Cincinnati Milling and Grinding Machines Inc.**

**Typical Research Groups**

**Cincinnati Milling and Grinding Machines Inc.**  
**Naval Ordnance Test Station**  
**University of Michigan**  
**Westinghouse Electric Corporation**  
**University of Vienna**

**Category V. Orientation and Texture Studies**

**Typical Programs**

**Strength and Plasticity of Anisotropic Metals**  
**Structural Changes in Anisotropic Materials by High Pressures**  
**Orientation and Texture Studies During Rolling of Titanium Sheet Materials**  
**Effect of Crystallographic Textures of Several Anisotropic Metals on Deformation**  
**Deformation and Texture Studies in Tantalum and Molybdenum**  
**Thermo-Mechanical Studies on Beryllium Sheet**

**Typical Sponsors**

**Army Materials Research Agency  
Navy - Bureau of Weapons  
Air Force - Materials Laboratory**

**Typical Research Groups**

**Army Materials Research Agency  
Massachusetts Institute of Technology  
Air Force - Materials Laboratory  
Army - Watervliet Arsenal  
Pechiney Company - France  
Franklin Institute**

**Category VI. Friction and Wear Studies**

**Typical Programs**

**Extrusion Lubricants  
Effect of Surface Films on Mechanical Properties  
Surface Effects of Solids  
Effect of Surface on Mechanical Behavior of Metals**

**Typical Sponsors**

**Air Force - Materials Laboratory  
Navy - Bureau of Weapons**

**Typical Research Groups**

**Air Force - Materials Laboratory  
Thompson Ramo Woolridge, Inc.  
The Martin Company  
General Mills, Inc.  
Martin-Marietta Corporation**

**Category VII. Mechanics of Processing**

**Typical Programs**

**Mechanics of Deformation in the Rolling Process Using Visioplasticity Methods of Analysis**  
**Work-Hardening Phenomena**  
**A Study of Forging Variables**  
**Hot Working of Metal**

**Typical Sponsors**

**Army - Frankford Arsenal**  
**Navy - Bureau of Weapons**  
**Air Force - Materials Laboratory**

**Typical Research Groups**

**Army - Frankford Arsenal**  
**University of California**  
**United Aircraft Corporation**  
**Battelle Memorial Institute**  
**University of Birmingham, England**

**Category VIII. Superplasticity**

**Typical Program**

**Evaluation of Superplasticity Phenomena Applied to Difficult-to-Process Metals**

**Typical Sponsor**

**Army - Frankford Arsenal**

**Typical Research Group**

**Army - Frankford Arsenal**

APPENDIX B

Excerpts from DMIC Report 187 :

THE APPLICATION OF ULTRASONIC ENERGY IN THE  
DEFORMATION OF METALS

Report on an Informal Symposium

Summary

"On June 21 a symposium was sponsored by the Bureau of Naval Weapons on the application of ultrasonic energy in the deformation of metals. At this session, a number of investigators actively working in the field reported informally on the results of their research. The reports revealed that the results achieved by incorporating ultrasonic transducers into conventional metal-forming and -cutting operations are sufficiently promising that the technique merits further attention. Data are available to indicate that application of ultrasonic vibrations during metalworking can increase speeds, lower forces, and improve surface finishes. All of these results have been obtained without any observed difference in properties between ultrasonically and conventionally fabricated parts.

"During the meeting the use of this technique was demonstrated in many common forming operations (drawing, grinding, tapping, extrusion, rolling), mainly on materials with low yield strength and low creep resistance (zinc, lead, aluminum, etc). There was no agreement as to the cause of the improved fabricability, both a lowering of the yield stress and a reduction of friction being suggested.

"Some details on design of experimental and pilot-plant equipment are given".

Presentations were made by:

Dr. B. Langenecker, Naval Ordnance Test Station, China Lake, California.

Professor L. V. Colwell, University of Michigan, Ann Arbor, Michigan.

Mr. A. T. Robinson, Naval Ordnance Test Station, China Lake, California.

Dr. C. A. Boyd and Mr. N. Maropis, Aeroprojects, Inc., West Chester, Pennsylvania.

Dr. C. A. Boyd and Mr. H. Kartluke, Aeroprojects, Inc., West Chester, Pennsylvania.

Mr. B. Mainwaring, Uniform Tubes, Inc., Collegeville, Pennsylvania.

Dr. W. B. Tarpley, Jr., Aeroprojects, Inc., West Chester, Pennsylvania.

Dr. R. R. Weber, Cincinnati Milling Machine Company, Cincinnati, Ohio.

Mr. H. L. McKaig, Jr., Aeroprojects, Inc., West Chester, Pennsylvania.

#### Suggestions For Future Work

"(1) If the use of ultrasonics is to spread, one of two conditions must be met: its use must either make the production of materials and shapes now being fabricated more economical or it must permit the fabrication of materials which cannot now be handled by conventional processes. A good example of the former is the report of Uniform Tubes, Inc., that, by using ultrasonics, the number of drawing reductions can be reduced from three to two in producing thin-walled aluminum tubing. On the other hand, few data have appeared which would indicate that ultrasonics will be a help in fabricating refractory or brittle materials. The most sensational results have been obtained on materials such as zinc, lead, aluminum, and copper which are quite ductile and have little creep resistance. From the viewpoint of the MPEP program, interest in ultrasonic forming is contingent on its ability to fabricate materials possessing good creep resistance. Since it has not been shown that ultrasonic forming will provide a solution to this problem, a demonstration of improved fabricability in any one of a number of refractory alloys should have top priority. For example, F48 is a columbium-base alloy which showed good promise as a high-temperature material but which has been largely written off, mainly due to its lack of fabricability. Another case is the alloy composition  $Nb_3Zr$  which could be the basis for large-scale introduction

of superconductivity in the electrical industry.

"(2) In using ultrasonic energy in metal deformation, design of equipment and monitoring of experiments appear to be difficult. The installation of ultrasonics requires experience in use of transducers and in the design of resonating systems. Furthermore, questions such as where to apply the vibrations, should vibration be axial, radial, or flexural; and what frequencies and amplitudes are optimum must be answered separately for each operation and each piece of equipment. Equipment must be designed which will optimize the delivery of ultrasonic energy to the workpiece and guidelines for answering the above questions should be developed. The monitoring problem must also be considered. It is easy to measure the power input to the transducer, but very little has been done to measure the power delivered to the workpiece. Measurements of temperature rise of the workpiece have not been reported, although this may be an important effect as suggested by the buildup of metal on wire-drawing dies in experiments at the U. S. Naval Ordnance Test Station. Finally, although speeds are relatively easy to measure, caution should be used in analyzing reported drawing tensions since sophisticated rapid-response electronic gear must be used to make such measurements accurately. More data on speeds, efficiencies, and tensions are certainly needed. Programs such as that initiated at Cincinnati Milling Machine should provide the answer to the question of whether friction or yield-point effects (or both) are causing the reported improvements in fabricability.

"(3) Even if the yield-point effect proves to be of minor practical importance in forming operations, its undoubted existence presents a challenge to the theoretician. It is strange that the large amount of prior effort in the field of internal friction did not predict this effect. Its cause is also unknown, and a valid mechanism for absorption of ultrasonic energy is needed. Transmission electron microscopy of conventionally and ultrasonically formed materials would be helpful. Perhaps fatigue data will give information on what effects are to be expected at low frequencies and will be useful in determining optimum frequencies".

APPENDIX C

Excerpts from DMIC Report 199

**THE APPLICATION OF HIGH PRESSURE IN  
METAL-DEFORMATION PROCESSING**

**Report on an Informal Symposium of the  
Metalworking Processes and Equipment Program**

Summary

"On October 3, 1963, a symposium was sponsored by the Bureau of Naval Weapons, Metalworking Processes and Equipment Program, on the application of high pressure in metal-deformation processing. Informal talks were given by eight investigators actively working in the field, covering both fundamental and applied aspects of high pressure effects.

"Past research, largely by Bridgman, has shown that superimposed hydrostatic pressure can significantly increase the ductility at fracture of various materials. These observations have stimulated considerable interest in applying this hydrostatic-pressure effect to metal deformation processing, where it was anticipated that improved ductility and fabricability of brittle materials could be realized. Hydrostatic extrusion and hydrodynamic compressive forging were two such fabrication techniques discussed at the symposium, and preliminary results were found to be encouraging. Another fabrication process that will be investigated in the near future is sheet drawing, where the effect of superimposed pressure on drawability will be evaluated.

"Although it is generally observed that testing under high pressure improves the ductility to fracture, it was noted that pressure cycling did not improve either the strength or ductility of steels containing various amounts of carbon. In addition to the mechanical-property effects, hydrostatic pressure has been found



to affect measurably, numerous metallurgical properties of metals and alloys. These include modes of deformation: kinetics of recovery, recrystallization, and grain growth; and phase stability".

Presentations were made by:

Mr. T. F. Kearns, Head, Metals Branch Bureau of Naval Weapons, "High Pressure Studies in Relation to MPEP".

Dr. A. Bobrowsky, Pressure Technology Corporation, "Background on Deformation of Metals Under High Pressure".

Mr. H. L. D. Pugh, National Engineering Laboratory, East Kilbride, Scotland, "Effect of High Pressures on Metal Deformation".

Dr. A. Kulin, ManLabs, Inc., "Effect of High Pressure on Metals".

Mr. T. E. Davidson, Benet Research and Engineering Laboratories, Watervliet Arsenal, "Effects of Pressure on Structure and Deformation of Metals".

Mr. Robert Fiorentino, Battelle Memorial Institute, "Hydrostatic Extrusion".

Dr. H. C. Rogers, General Electric Company, Research Laboratory, "Drawing of Sheet Metal".

Mr. Richard M. Cogan, Thomson Engineering Laboratories, General Electric Company, "Hydrodynamic Compressive Forging".

## Suggestions for Future Work

### "Process Development

"Although the hydrostatic-pressure effect has been applied with encouraging results (at room temperature) to hydrodynamic compressive forging and hydrostatic extrusion, more research and development is required to fully evaluate these fabrication techniques. In particular, it is important to determine the subsequent mechanical properties of materials fabricated by these means to check for uniform-

ity and to compare with the properties of materials fabricated by more conventional techniques. Future work should also include efforts to apply these fabrication methods at elevated temperatures. Development of equipment with high-temperature capabilities will probably be necessary before these techniques can be successfully applied to fabrication of high-strength, high-melting-point materials. Additional research appears to be warranted to determine the mechanisms of lubrication during hydrostatic extrusion.

#### "Modes of Plastic Deformation

"(1) Considerable work is required to evaluate the modes of plastic deformation of materials tested with a superimposed hydrostatic pressure (e.g., slip, twinning, stacking faults, deformation bands, and kink bands). The utilization of special techniques, such as transmission electron microscopy, has provided substantial information regarding deformation mechanisms, but this type of work has not, as yet, been applied extensively to materials deformed under high hydrostatic pressures.

"(2) Recent (unpublished) experiments by E. P. Bullen and H. L. Wain in Australia have shown that brittle, recrystallized chromium becomes ductile at ambient temperature and pressure after being subjected to large hydrostatic pressures. For example, the room-temperature (1 atmosphere) ductilities were found to be as follows:

- "(a) Unpressurized - 0 per cent elongation, 0 per cent reduction in area
- "(b) Pressurized at  $10^4$  atmospheres - 65.4 per cent elongation  
47.3 per cent reduction in area

The ductilizing effect is probably the same as that due to prestraining above the ductile-to-brittle transition temperature. Prestraining removes the yield point by the introduction of fresh dislocations, and it is probable that the absence of a yield drop after pressurization is also caused by generation of mobile dislocations. This in turn could lower the propensity for twinning, which is one potent mechanism of crack initiation in chromium (e.g. at twin/twin and twin/grain boundary intersections). The mechanism of dislocation generation under pressure is still now known however, and it appears that some further research is warranted. In addition to such investigations, it might be of practical importance to determine whether complex shaped parts of brittle materials (which cannot be conveniently prestrained by normal methods) could be ductilized by hydrostatic pressurization".

## SOME TECHNICAL ASPECTS OF THE U. S. METALWORKING PROCESSES AND EQUIPMENT PROGRAM

---

by N. E. Promisel

A previous speaker has described the scope, objectives and general organization of the Metalworking Processes and Equipment Program. Essentially, in this paper I want to describe to you in greater detail some specific examples of the phenomena and metal behavior which we think must be considered in looking ahead to new processing techniques and new equipment.

Let me remind you first of two basic features of this program: The first point is that our objective is to develop techniques and equipment which are adjusted to the characteristic behavior of the material, instead of trying to modify the material to be "workable" in equipment or under conditions which have been developed for something else. It is not reasonable to expect to be able to roll most efficiently refractory metals like tungsten or some niobium alloys on rolling mills designed for rolling mild steel. The forces, temperatures, speeds, strain rates, etc. required for efficient processing are entirely different in both cases. Too often, a newly developed alloy has been deliberately made "weaker" because it could not be processed by conventional techniques. Unless we take a giant step forward, we can expect the situation to get worse, because so much effort is now being spent to deliberately develop materials which resist deformation at higher stresses, at higher temperatures for longer times, etc. Obviously, we must develop techniques and equipment which permit processing these materials without sacrificing this greater resistance to deformation in service.

The second feature of this program that I would recall to you is this. Since we are attempting to hold to a minimum any change in the material for the purpose of easing its processing, but which could be detrimental in other respects, it is necessary to examine thoroughly and basically the deformation characteristics of

the material and new concepts or phenomena which might help in designing new equipment and new conditions for processing. Fortunately, there has been considerable research work on metal deformation phenomena and we have many new tools to help us. Figure 1 lists some of these in which there are very interesting and even exciting possibilities. There is opportunity to refer to only some of these in this rather limited paper, but these are the kinds of things I plan to discuss; namely, the research and development work described by the previous speaker as Phase 2 of this program.

It is evidently not easy to identify all the necessary subjects for study and to take into account all the work that is going on in this field. It is for this reason, as mentioned by the previous speaker, that a broad and comprehensive organization is important and has been established to assist in this program. Figure 2 is an early outline of the organization, as it affects the U. S. Navy program.

Now let us look more specifically at some of these effects, starting with certain ultrasonic phenomena. In 1955, Blaha and Langenecker discovered a softening effect in zinc single crystals that were exposed to the influence of ultrasonic waves. They attached an ultrasonic transducer to the end of a tensile specimen and recorded stress strain characteristics. The result was a drop in apparent yield stress while the specimen was under the influence of the ultrasonic waves. Dr. Langenecker is now at one of the Navy laboratories in California and has repeated similar tests using single crystal aluminum and polycrystalline stainless steel and beryllium. Some results are shown in Figure 3. It will be noticed that the stress necessary, in stainless steel and beryllium, to achieve a certain percentage elongation drops very markedly as the ultrasonic energy is increased from zero up to about 600 watts per square inch. In Figure 4, there is a similar drop for aluminum. This drop in the stress strain curve can also be achieved by increasing the temperature at which the specimen is tested without ultrasonic vibrations as shown in the right hand side of the figure, but if we calculate the energy necessary to achieve this drop in yield stress by using heat and compare it with the estimated energy to achieve the same result using ultrasonic energy, the latter is sufficiently less to suggest a very definite effect from the ultrasonic waves themselves, independent of any temperature effects which might have resulted. This observation has been confirmed on tungsten where the difference between heat and vibrational energies for the same results is much greater. It is believed that this effect is due to the activation of dislocations by the ultrasonic energy, in their dissipation of the ultrasonic waves, permitting them to move under very small applied stresses, certainly smaller than would normally be necessary for the indicated amount of plastic deformation.

This reduction in yield stress could be very important in design of new equipment for metal processing. A reduction in the force necessary for a certain degree of deformation should make possible some major reductions in the equipment size, for example in rolling wide sheet or the rolling of very difficult alloys.

Although this is very encouraging, nevertheless we should not overlook some serious problems, such as the means for introducing ultrasonic energy into the work and properly controlling it. However, the attractiveness of this possibility in the design of new equipment is such that we are vigorously pursuing this phenomenon. In fact, some tests are now being run in a very small experimental rolling mill.

Another advantage of using ultrasonic vibration in metal working is the reduction of frictional forces. Tube drawing experiments have been run. Figure 5 shows results for copper, using hydraulic force to give a constant drawing rate. The decrease in drawing force when the ultrasonic power was applied is very marked. In Figure 6, a dead weight was used to obtain a constant drawing force for copper and zircalloy tubing. Here the increase in drawing rate is very noticeable. The implication of these data is that much heavier reductions per pass can be obtained using ultrasonics, since the mechanical properties of the final tubing are not affected. In fact, advantage is already being taken of this in industry for small diameter tubing. A free bonus is the impressive improvement in interior surface finish of aluminum tubing, due to reduction in friction by drawing the tubing over a vibrating mandrel. Ultrasonic vibration also has advantages in other forming operations; for example, in reducing forming forces and, in the case of die forming, filling the dies better. Figure 7 shows a curled tube cross-section, using only half the normal force.

Of course, there are some limitations to the advantages of using ultrasonic vibrations for reducing friction. For example, the biggest improvements are at very slow drawing speeds, and as the drawing speed increases the advantage of using vibrated dies decreases. Also, it might well be that with the use of the proper lubricants and the proper die design we might obtain just as effective results even more practically. However, it is important to recognize that we have in ultrasonic vibrations an additional tool in metal processing; for example where the use of lubricants might prove to be difficult to use at high temperatures, ultrasonics could be effective.

#### Effect of ultra high pressures

Bridgman appears to have been the first person to have investigated quantitatively the effect of pressure on the tensile properties of materials. He showed, with others, that the log of the reduction in area was a linear function of pressure, the equation\* containing only two constants which could be readily determined, at

$$* \text{Log} \frac{\text{original area}}{\text{final area}} = C_1 + C_2 P$$

least approximately. This equation has been confirmed for steels and for some aluminum alloys but does not appear to be true for all metals. For example, brass appears to gain little in ductility above about 90,000 psi. In tests on polycrystalline zinc, Pugh observed what appeared to be a transition pressure of about 8,000 to 12,000 psi below which reductions of area were less than 10% and above which the reductions of area approached 100%; that is, there was by no means a smooth linear relationship here.

Figure 8 shows tensile tests of pressed and sintered tungsten. The specimen on the extreme right shows the normal brittle tensile fracture at room temperature and pressure. At the extreme left is a ductile fracture when a hydrostatic pressure of 250,000 psi was used during testing, and in the center is a specimen which did not break when pulled to the capacity of the equipment under a pressure 350,000 psi but which showed considerable ductility. Polycrystalline tungsten seemed to remain brittle at room temperature up to pressures of about 110,000 psi. Above this amount it should be possible to deform tungsten a significant amount depending on the value of the pressure surrounding it. Figure 9 shows similar results of room temperature compression tests on small cylinders of beryllium. On the right hand side the edge cracking when the tests were run at atmospheric pressure can readily be seen. On the left hand side are the results obtained when the same amount of compression was performed under a fluid pressure of 150,000 psi and it is evident that there is considerable less edge cracking if any, thus indicating much greater ductility of the beryllium under pressure.

The results which I have just described on the impressive increase in deformability of tungsten and beryllium, confirmed by rather extensive tests on a variety of other metals, open up a very fruitful avenue for improving metalworking processes. It is worth noting that in those processes where the metal is actually being deformed under high pressures, due to the mechanical constraints and forces imposed on it, the metal's properties may well be different from those we measure in the laboratory at atmospheric pressure, and therefore these laboratory properties cannot be safely used to predict deformation during processing.

Fluid to fluid extrusion

Some very interesting work has been done in extrusion by substituting for the conventional ram a high fluid pressure, and forcing the material through the die into a lower fluid pressure container. This approach is shown schematically in Figure 10. Although this process has certain inherent problems such as the compatibility of the pressure fluids with temperature, this approach has the advantages of a considerable reduction in friction both in the die and on the cylinder

walls, the ability to minimize hoop tension forces on the die because of the counterbalancing hydrostatic forces, and the opportunity to modify the process by extruding from a very high pressure fluid into a lower pressure environment which nevertheless is still relatively high. In the diagrammatic sketch of Figure 10, the receiving area which is marked as being at low pressure ( $p$ ) is nevertheless above atmospheric pressure, even as high as a few hundred thousand pounds per square inch.

The work done thus far on this type of fluid extrusion has been limited to fairly small pieces, approximately two inches in diameter, but there does not seem to be any basic limitation on the process, other than the cost and difficulty of making high pressure equipment of the proper size. Pressures up to now have varied from less than 40,000 psi to about 450,000 psi maximum chamber pressure.

Figure 11 illustrates the results of tests of this type of extrusion on TZM molybdenum alloy which was deliberately recrystallized before extrusion, thus increasing the expected difficulty for good extrusion. The cracked specimen in the lower part of the figure was obtained by extruding into an atmospheric pressure zone. The uncracked specimen on top, which received the same 22% reduction was extruded into a receiver fluid at 40,000 psi. Tests on a sintered tungsten rod also gave a very sound extrusion at 14% reduction when the receiver pressure was raised to 150,000 to 200,000 psi.

### Texture

It is readily recognized that mechanical properties of metals and alloys can vary very markedly with crystal orientation. This certainly is the case in most hexagonal crystalline metals, where the anisotropy in mechanical properties is generally considerable, and this is likely also in some of the cubic systems. Therefore, crystal orientation and texture generally can be expected to be very important considerations in metal processing.

An example of the effect of crystal orientation may be found in the study of single crystals of beryllium. At room temperature and pressure, there are just three modes of deformation for the beryllium, as seen in Figure 12: slip on the basal (0001) and prism (1010) planes; and twinning on the (1012) plane. It should be noted that both of the slip directions are perpendicular to the "c" axis of the crystal; thus there is no extension along that axis. The twinning mode does give a minor change in length along the "c" axis but requires a lateral displacement to do so. In studies of the effect of even traces of impurities on the strength

and ductility of beryllium, a very great improvement in elongation as a result of basal slip was obtained by zone refining a single crystal until a very high degree of purity was obtained. Figure 13 shows the increasing elongations obtained as the purity was increased by increasing the number of zone refining passes. Corresponding reductions of the critical shear stress on the basal plane are also seen on this figure. In Figure 14 there is illustrated a tensile failure of a pure single crystal of beryllium with the basal plane oriented originally at about  $40^\circ$  to the longitudinal axis of the specimen. One could certainly expect that there should be little fabrication difficulty with a material that appears to be so ductile, i. e. with this high degree of elongation.

However, tests have been run on this apparently "ductile" material by loading single crystals in compression perpendicular to the basal plane. The results gave no evidence of plastic flow, and the stress level in both cases in these tests reached about 285,000 psi before the specimen shattered and flew in all directions. Yet in tension, this material showed 140% elongation! However, such results are not really surprising when one recalls that there is no slip mode that exists along the "c" direction at room temperature and recalling that the twinning mode is restrained by the lateral constraint of the faces of the die.

While this illustration may seem somewhat extreme, it does illustrate the importance of orientation and texture in deformation processes and the danger of generalizing or extrapolating from just limited tests.

### Superplasticity

A fascinating phenomenon that might prove to be very important in new concepts of metal deformation has to do with the unusual and often contradictory changes in plasticity that occur under conditions associated with structural changes in the atomic lattice such as phase changes and certain order-disorder reactions, presumably associated with the temporary breaking of atomic bonds. No effect is noted if there is no change in lattice parameter and conversely the greatest elongations correspond to the greatest changes in lattice parameter. A classic example is some work done by Sauveur in the torsion testing of iron over a temperature range of 600-1200°C. This may well be the earliest work representative of this phenomenon. Sauver and others since him found a relatively sharp increase in ductility near the gamma to alpha transition as the temperature decreased. Fig. 15 illustrates this phenomenon in the form of Sauveur's torsion results. A series of iron bars was heated at the centers to the temperatures indicated and simultaneously twisted in torsion. Obviously, when the temperature was high enough at the center, considerable ductility was shown as indicated by the twists in the bars.



However, at certain lower temperature areas along the bars, there was just as much ductility if not more than at the center or point of maximum temperature. These zones correspond to the  $A_{r3}$  temperature for that material. It will be seen that between the center of the bar and the  $A_{r3}$  zones there is not the same ductility, even though the temperatures were sometimes higher than those of the  $A_{r3}$  zones. In other words, where the phase change was taking place, an unusual degree of ductility was observed. Figure 16 illustrates this phenomenon in more recent work. Here a low carbon steel bar was loaded in tension at a relatively low load, corresponding to 400 psi. When the center of the bar was cycled from 800 to 1000°C so that parts of the bar reached the critical temperature corresponding to the phase change, unusual elongations were observed at these areas as compared with the center of the bar where the temperature was actually higher, but too high for a phase change. This change in elongation is shown on the two curves.

This ductility phenomenon, referred to for convenience as superplasticity, has been studied in Russia extensively for about the last twenty years. The most dramatic and spectacular elongation in some of this Russian work was obtained with aluminum-zinc alloys near the eutectoid composition (80% zinc) at 275°C, where elongations of about 650% were found without failure taking place. It is evident that there exists a number of conditions in many alloy systems where there is very low resistance to deformation and where one can find an extremely high degree of plasticity, beyond that expected for the material even at much higher temperatures. Besides the systems already mentioned, the phenomenon has been found near the phase boundary of nickel alloys with chromium, copper, and in various other aluminum systems, magnesium systems, copper-zinc systems, copper-nickel systems and others.

There is by no means agreement on a good explanation for superplasticity that fits all the observed data or even agreement on a good definition of superplasticity. Evidently, the phenomenon is related to a distortion of the atomic lattice under the application of stress, the availability of a metastable structure for subsequent stressing, and the weakening of the interatomic bonds that takes place during the reconstruction of the crystal lattice, as the alloy achieves a state of equilibrium. One dislocation mechanism to explain some of these observations, by Porter and Rosenthal, suggests that piled-up dislocations at grain boundaries and at other barriers produce stress fields which result in increased rate of nucleation. When the nucleus starts growing, the advancing interphase provides a sink for the piled-up dislocations resulting in observable plastic deformation. This suggested mechanism explains some observations but certainly not all. However, as further work continues in an attempt to derive explanations in terms of vacancies, dislocations, crystal structure, etc., it is hoped that the phenomenon itself may become useful in the development of new deformation processes.

## Conclusion

In concluding my remarks on our metalworking processes and equipment program, I would like to point out that the examples which I have given of a variety of factors, from ultrasonics through superplasticity, merely represent examples of a considerable body of knowledge which exists in the literature and represents a tremendous amount of work still continuing on the behavior of metals, which we hope can be taken into account in developing new processes and new equipment. One of the main features of this program is the complete freedom to try to adopt any new concept and any new metallurgical phenomenon to the design of new equipment or to the development of a new technique. It is difficult, of course, to predict with any certainty the results of a program such as this. However, although this program was started primarily to permit practical processing of difficult materials which, almost by definition, are hard to deform, it seems clear to me that if we are successful in this objective, there is also a good likelihood that we will have developed techniques and equipment which are cheaper, simpler, more productive or otherwise have advantages even for the more common metals. It is hoped that by distributing the information from this program, widely, in the form of reports and publications, there will be stimulation for many to try to apply this information to new equipment. It is conceivable, therefore, that in years to come there could grow up a different kind of processing industry which could have a significant effect on the economy, not only of metal working, but on the final metal products themselves, and in turn these could involve large sections of a country's activities --the industrial organizations, the material producers, the fabricators, the equipment builders. Where big investments in capital equipment do not already exist, there would seem to be particularly good opportunities to take advantage of new concepts and new developments. One could hope, also, that these practical applications would in turn inspire further studies in science and technology, thus furnishing that productive exchange between science and engineering application which all of us are trying to achieve.

## Acknowledgment

It has already been stated in this paper that one of the precepts of this program was the conclusion that there existed considerable data, and descriptions of a multiplicity of phenomena, which were, in essence, awaiting application to metal working process improvement. I have drawn freely, therefore, not only from investigations generated by the U.S. Navy, but from many other sources and reviews too numerous to list by detailed references. Included, for example, were Langenecker, Robinson, Eridgman, Bobrowski, Herman, Kaufman, Under-

wood, Rathenau, Sauveur, Sherby, Kearns.--to mention only some by name. To all of these sources of data and information I give grateful acknowledgment.

## DEFORMATION CONSIDERATIONS

ULTRASONIC EFFECTS  
 FRICTION, WEAR, AND SURFACE-  
 EFFECT STUDIES  
 HIGH-PRESSURE EFFECTS  
 DEFORMATION MODES  
 ORIENTATION AND TEXTURE  
 STUDIES  
 STRAIN-RATE TEMPERATURE  
 SUPERPLASTICITY

Fig. 1 New tools for metal deformation.

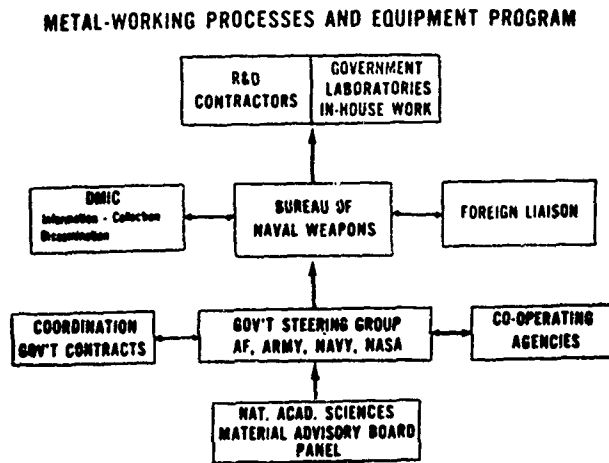

Fig. 2 Early outline of the Organization as it affects the U.S. Navy Program.

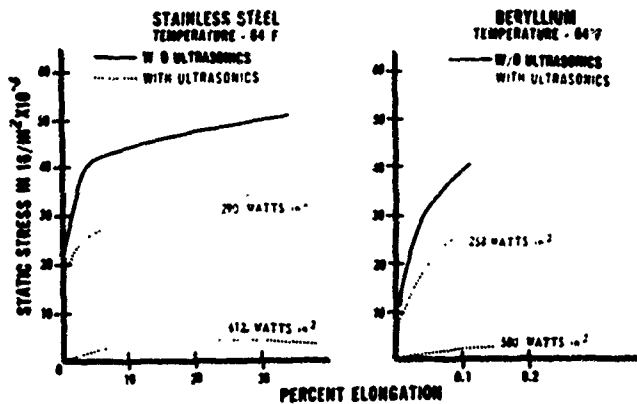

Fig. 3 Effect of ultrasonics on the yield stress of polycrystalline stainless and Beryllium.

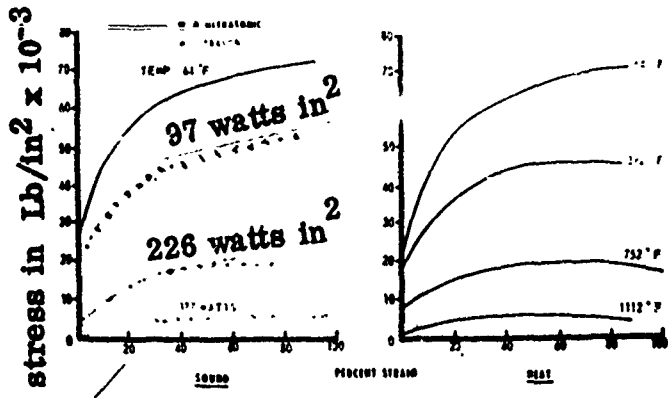

Fig. 4 Room temperature deformation of aluminum under influence of ultrasonics vs. deformation without ultrasonic activation at elevated temperatures.

ULTRASONIC TUBE DRAWING - COPPER  
Hydraulic Draw Bench - 20 KC/sec.

Dimensions-inches				Percent Area Reduction	Ultrasonic Power Level Watts (Input)	Force lbs. (Drawing)	Rate in./min.	Percent Force Reduction
Initial		Final						
O.D.	Wall	O.D.	Wall					
0.313	0.032	0.225	0.019	57	0	1800	15	-
					500	815	15	35
					1000	680	15	68
0.213	0.032	0.275	0.032	12	0	1950	60	-
					1000	815		42
0.275	0.032	0.225	0.019	50	0	1260	60	47
					1000	725		

Aeroproducts, Inc.

Fig. 5 Tube drawing experiments for Cooper under constant drawing rate.

ULTRASONIC TUBE DRAWING - COPPER AND ZIRCALOY-2  
Deadweight Drawing Apparatus - 20 KC/sec.  
Ultrasonic Power Level - 1000 Watts.

Material	Dimensions-inches				Percent Area Reduction	Condition	Draw Force lbs.	Rate in./min.
	Initial		Final					
	O.D.	Wall	O.D.	Wall				
	0.213	0.032	0.275	0.032	13	Control	410	217
						Ultrasonics	410	2600
Copper	0.213	0.032	0.250	0.0315	24	Control	395	0
						Ultrasonics	395	7.5
	0.275	0.032	0.250	0.0315	12	Control	616	0
						Ultrasonics	670	171
Zircaloy-2	0.250	0.025	0.225	0.025	19	Control	870	0.25
						Ultrasonics	1000	26

Aeroproducts, Inc.

Fig. 6 Tube drawing experiments for Cooper under constant drawing force.

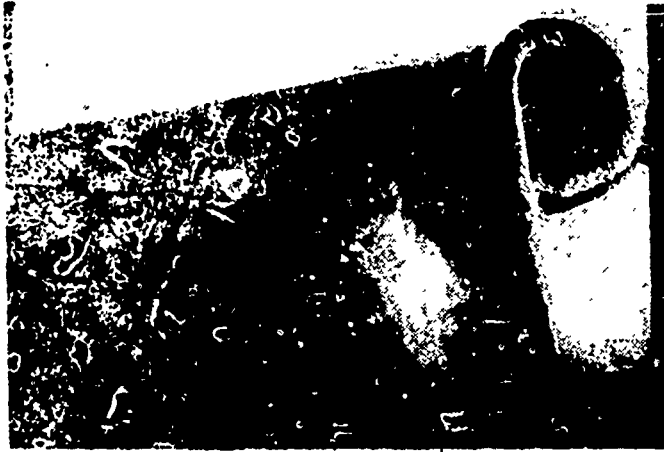

Fig. 7 Effects of ultrasonics on Die Forming.



Fig. 8 Tungsten rods in presses and sintered Tungsten.



Fig. 9 Effects of high pressure on the deformation behavior of Beryllium.

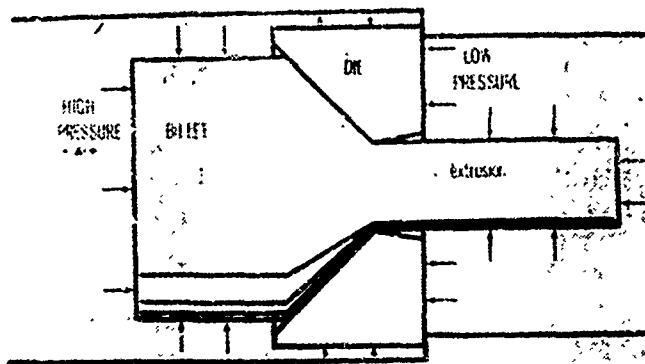

Fig. 10 Sketch of the set up for fluid to fluid extrusion.

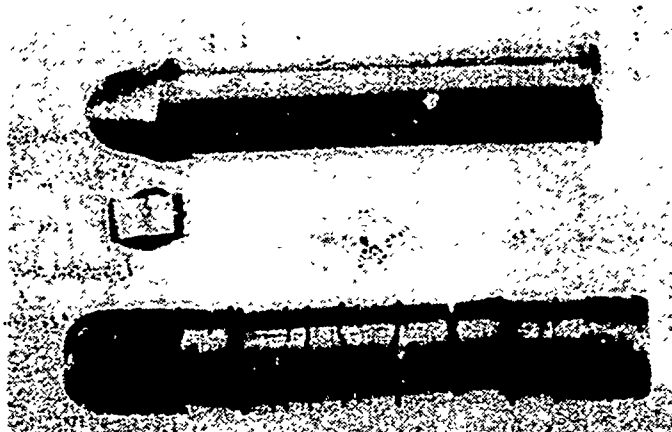

Fig. 11 Results of fluid to fluid extrusion on TZM Molybdenum.

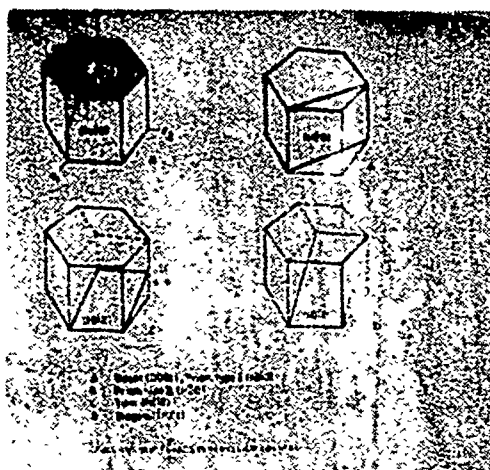

Fig. 12 Deformation Modes for Beryllium single crystals.

## TENSILE TESTS OF ZONE REFINED BERYLLIUM CRYSTALS

Angle Between Axis and Basal Plane	No. of Passes	Deformation Mode	Elongation			Critical Stress Kgr. cm <sup>-2</sup>
45°	Ref. melted Crystals	Basal	1	1	-	2500
45°	2	Basal	8.0	8.1	18	1750
45°	8	Basal	50.2	100	160	500

Fig. 13 Effect of purity on the elongation on critical shear stress of Beryllium single crystals.

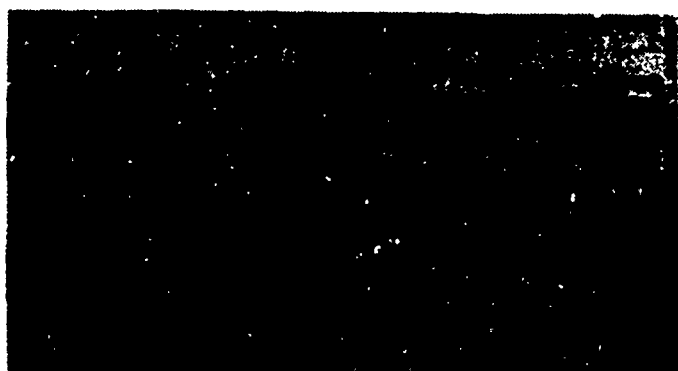

Fig. 14 Tensile failure of a pure single crystal of Beryllium.

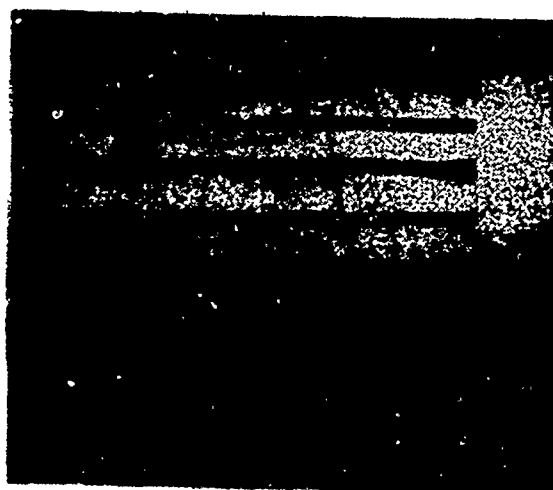

Fig. 15 Sauveur's Torsion results.

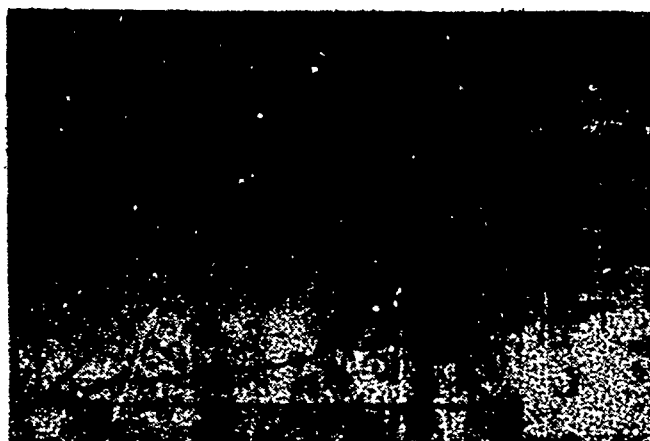

Fig. 16 Superplasticity of Iron with 0.03% Carbon.



## MATERIALS RESEARCH IN SUPPORT OF ADVANCED TECHNOLOGY

---

by S. Valencia and P.A.G. Carbonaro

### Introduction

The United States Army maintains an active research program to improve existing materials and to develop new materials. Advanced technology is fundamental for developing optimum materials which can be applied economically in military components.

Current trends of weaponry call for lighter weights, more intricate designs, higher strengths, greater toughness, and, for certain applications, resistance to high temperatures. These requirements, coupled with increasing labor costs, make research essential. Not only is such research necessary, but there is a need for the simultaneous accumulation of engineering data on new materials emerging from the research laboratories. When a new production technique is suggested for economic consideration, the effect of the new processing technology on engineering properties must be determined before that technique is qualified for productive purposes.

The United States Army Materials Research Agency, located at Watertown, Massachusetts, has a responsibility for the over-all broad Army program on materials research. This paper covers the following selected areas of interest:

- a. High-Strength Steel Castings

- b. Precision Forming Techniques - Cold Swaging
- c. Sub-Fusion Temperature Bonding
- d. High Energy Rate Forging
- e. Metal Removal

These processes augment rather than replace existing metal-shaping techniques and, when properly applied, produce highly superior products. However, it must be cautioned that before the processes are adopted, a study should be made to determine if they are practical and economical.

#### High-strength steel castings

Shape castings play an important role in weapon components because they lend themselves to intricate designs and offer great economic incentives over shapes fabricated by competing methods. In recent years, with the achievement of ultra-high strengths in steels, there has been an apparent need<sup>(1, 2)</sup> for upgrading the technology associated with the production of shapes from these high-strength steels. Accordingly, there has been a steady effort in the area of metals research directed at obtaining a better understanding of the fundamentals involved in the production of a cast shape. Increasing the basic knowledge in solidification of high-strength steels, fluid flow, mold-metal reactions, response to thermal treatment, etc., would provide a firm basis for the design and processing of military castings.

Two important areas of immediate consideration were determined by the United States Army Materials Research Agency to be melting and refining, and solidification. Melting and refining determines inherent metal quality, while the manner in which metal solidifies determines the size and distribution of the grain.

## Research on Melting and Refining

It is generally recognized that sulfur content is an important influencing element in steels. The greater the sulfur content, the poorer the mechanical properties since the sulfur tends to segregate during solidification. Because of this tendency, the effect would be more pronounced with a cast shape than with a forged structure. Standard methods of desulfurization employing a double slag basic arc furnace procedure<sup>(3)</sup> were investigated as well as rapid desulfurization techniques<sup>(4)</sup> that can be conveniently employed on small, experimental induction-melted heats. The results of these investigations are graphically illustrated in Figures 1 and 2.

In Figure 1 the ductility and toughness of arc furnace steels at constant strength levels are plotted against sulfur content. Improvement in ductility and toughness can be readily seen as the sulfur content decreases. Whereas in forged steels sulfur content below 0.025 percent is of little concern, in the case of steel castings there is a direct proportional increase in ductility with decrease in sulfur content even with comparatively small amounts (0.010 percent) of sulfur. The effect of sulfur upon the mechanical properties becomes even more pronounced at the ultra-high strength levels.

Figure 2 shows, in bar-graph form, the effect of sulfur content on steels at the tensile strength range of 275,000 to 300,000 psi. Silicon-modified 4340 steels at extremely low sulfur levels were compared with similar steels at the 0.017 percent level. The basic analyses and heat treatments were the same, and yet by decreasing the sulfur content there was as much as a twofold increase in ductility which is attributed directly to the decrease in sulfur content. The data in both Figures 1 and 2 represent results of controlled experiments where the sulfur content was the only variable.

This type of data, combined with similar results from other engineering laboratories and foundries, made possible the establishment of a specification for high-strength steel casting, MIL-S-46052 dated 28 September 1962. This specification, entitled "Steel Castings, High Strength, Low Alloy", cites the following combination of properties for high-strength castings:

### MECHANICAL PROPERTIES, MINIMUM

Class	Tensile Strength (psi)	Yield Strength 0.2% Offset (psi)	Reduction of Area (%)	Charpy V-Notch Impact Energy at -40 C (ft-lb)
180 - 150	180,000	150,000	20.0	15
220 - 180	220,000	180,000	15.0	12
260 - 210	260,000	210,000	6.0	9

With this limited but significant amount of work directed toward upgrading the melt quality, research effort was then increased in the area of solidification.

#### Solidification Research

The vulnerability of high-strength steels to metallurgical size effect has been established but the exact cause for this effect has been the basis for a continuing study program. The effect could be due to grain size, nonmetallic inclusions (size and distribution), microporosity microsegregation, or a combination of these variables. Studies of these variables have been underway at a number of laboratories and universities<sup>(5,6,7)</sup> under Department of the Army sponsorship.

Of particular interest in this general area of solidification research has been the study of dendrites, their formation and character.

Laboratory test ingots of silicon modified AISI 4340 steel were cast in such a manner as to provide a predetermined dendritic pattern. A typical test ingot is cylindrical, about 8 inches in diameter and 10 inches high, cooled so that dendritic structure will vary, giving the researcher columnar as well as equiaxed dendrites for study. Figure 3 shows a macrostructure of a transverse disk from such a test ingot. The structure was developed by etching in a solution of 38 percent hydrochloric acid, 12 percent sulfuric acid, and 50 percent water for 15 minutes at 170 F. The macrostructure contained a typical columnar zone in the outer portion with an equiaxed structure in the center portion.

The dendrites shown in Figure 4 were subjected to a variety of laboratory tests to determine microporosity, inclusions, and information on the extent of microsegregation within and at the boundaries of the dendrites. With the aid of an electron-beam analyzer it was possible to obtain quantitative chemical analyses of very small portions (1-1/2 microns in diameter) on the sample. By taking a series of analyses across a scan (a given distance), one can directly measure the change in chemical composition across dendritic arms. The size of a dendritic arm varies in the order of magnitude from 10 to 1000 microns and a rather complete analysis can be obtained from such a cross-scan distance. The only practical limitation for this technique is that quantitative chemical analysis cannot be obtained for elements below magnesium in atomic weight. Thus in the case of steel one cannot analyze for carbon, phosphorus, and sulfur, but all other elements of interest can be determined with the help of the probe. Typical results of the probe analysis are shown in Figures 5, 6 and 7 which indicate that conventional high temperature homogenization treatments have little effect on the diffusion of the segregated elements.

#### Future Requirements

Obviously any technique which may be generated to reduce the degree and size of segregation will enhance the over-all properties of the cast shape. In other studies the effect of size and type of dendritic structure is being scrutinized since the control of dendritic pattern within a cast shape will largely control the distribution of segregated areas. If the combination of properties listed below can be obtained as a result of this research program by establishing the necessary technology for actual manufacture, then the economical advantage is obvious for the production of complex military shapes.

Limitations to the wider use of high-strength steel cast shapes is primarily associated with current knowledge in the field, and the type of research described is required to establish the necessary fundamentals for ultimately advancing the state-of-the-art through new technology.

VI

**TARGET PROPERTIES FOR HIGH-STRENGTH,  
TOUGH, SHAPED STEEL CASTINGS**

Max. Crit. Section Size (in.)	Yield Strength 0.2% Offset (psi)	Reduction of Area (%)	Elongation (%)	Charpy V-Notch Impact Energy at -40 F (ft -lb)
3	160,000 - 169,999	25	14	24
	170,000 - 179,999	24	13	22
	180,000 - 189,999	23	12	20
2	190,000 - 199,999	22	11	19
	200,000 - 209,999	21	10	18
	210,000 - 219,999	20	9	17
1	220,000 - 229,999	19	8	16
	230,000 - 239,999	18	7	15
	240,000 - 249,999	17	6	14

**Precision forming techniques - Cold Swaging**

In another area, generally identified as "precision forming", the United States Army has been investigating comparatively new and modified processes which will yield a product requiring little or no machining in manufacture. The new precision-forming technique discussed herein is a further development of the well-known swaging process. This process was selected for investigation in an attempt to develop new techniques, not only to meet more exacting requirements and to produce a higher quality product, but also to offset labor costs. This particular process consists of the plastic reshaping of tubular workpieces by means of high pulsating pressure applications produced by rotating hammer dies. While the outside diameter of the tubular workpiece is being reduced, varied internal contours (such as splines) can be produced by introducing into the inside of the workpiece a contour mandrel whose shape can be reproduced on the inside of the tubular workpiece.

## Machine Tool

As part of a program sponsored by the United States Army for the development and application of the technique, a contract was negotiated with a commercial facility to design, develop, and construct a cold-swaging machine capable of producing intricate internal contours within cylindrical components. The resulting machine tool which is shown in Figure 8 was installed at the United States Army Materials Research Agency. The machine is composed of two main units: (1) the actual hammering unit known as the "head", and (2) the feeding unit known as the "slide".

The head contains the swaging mechanism which consists of all the components necessary to complete the hammering operation. The schematic drawings in Figures 9 and 10 show the main components of the head with the hammers in the closed and open positions. The shaft, in which the four hammers are located crosswise, is actuated by means of a 40-hp motor over a flywheel which is connected to the motor by V-belts.

The twelve rollers, equally spaced through the roller cage, are equipped at both ends of the rollers with a spacer ring. Spring power and centrifugal force effect a steady contact between the sinusoidal back surface of the hammers and one roller, and between the surface of the rollers and the liner. When the machine is in operation, the shaft rotates rapidly, at approximately 250 rpm. As a result of this rotation of the shaft, the hammers with their curved backs pass over the rollers, thus exerting a powerful squeezing action on the workpiece through the swaging dies. All hammers work simultaneously and the stroke is given by the high point of the sine curve on the back of each hammer. The hammers apply approximately 2000 blows per minute. Interchangeable dies may be used to permit the processing of tube sizes ranging from 1/2 inch to 3 inches outside diameter.

The slide contains the workpiece feeding mechanism which consists of a double screw drive with adjustable nuts. The screws actuate the slide carriage in which the freely rotating push rod supporting the workpiece is installed. The screws are driven by a Vari-Motor drive and chain drive over a cross-connected train of gears. This train of gears has two speed ratios and a special forward and reverse quick-feed gear. The feeding speed can be set to vary from 5 to 100 ipm. The slide is capable of feeding a workpiece with a maximum length of 60 inches and a maximum feed load of 40 tons.

Besides the head and the slide just described, the machine is equipped with a mandrel drive and a back pressure attachment. The mandrel drive is used to carry out all the movements necessary for the mandrel during the swaging operation and the back pressure attachment is required to guide and keep the workpiece

centered during swaging and to eject the work upon completion.

## Applications

Examples of applications which have been under investigation at the United States Army Materials Research Agency are: (1) rifling of small arms, and (2) forming of both chamber and rifling of small arms in one operation.

### Rifling Investigations

Typical of the investigations which have been conducted is the rifling of .30 caliber rifle barrels. The material used for the blanks was SAE 4150 steel heat treated to a  $R_c 32$ . The starting tubular workpieces used for these investigations were 1.350 inches outside diameter (O.D.), 0.348 inch inside diameter (I.D.), and 30 inches long. Figure 11 shows the dimensions of the workpiece prior to swaging, the rifled barrel after swaging, and the mandrel used for rifling. Based on these dimensions, the percentage reduction and elongation obtained was 14 percent. These tests have proved that the new technique can hold close tolerances and produce good surface finishes. As shown in Figure 11, the inside diameters have been held to within 0.0005 inch on the .30 caliber rifle barrels. In addition, the surface finish was improved from 75 microinches to an average of 8 microinches. Finally, the swaging speeds for these tests have been in the range of 10 to 15 ipm. Experiments have also been conducted with the rifling of .60 caliber and 20mm rifle barrels and the results have been successful.

### Swaging of Chamber and Rifling of Small Arms

In addition to the rifling tests, successful experiments have been conducted recently which include the swaging of both the chamber and the rifling of .30 caliber rifle barrels in one operation. The dimensions of the starting tubular workpieces used for these experiments were 1.350 inches O.D., 0.348 inches I.D., a length of 23 inches and a counterbore of 0.472 inch I.D. with a depth of 1.770 inches. Figure 12 shows the workpiece prior to swaging, the dimensions of the chamber and rifling after the swaging operation, and the mandrel tool employed. The chambering and rifling mandrel is a two-component tool joined in the manner shown by the drawing.



During the swaging of the chamber portion, both chamber and rifling mandrels travel forward together with the workpieces. Immediately upon completion of the chamber portion, the chamber mandrel separates from the rifling mandrel and continues travelling forward with the workpiece while the rifling mandrel is automatically locked in place within the throat of the dies and from then on cannot travel forward, although it remains free to rotate.

These experiments have further proved that the new technique can hold close tolerances and produce good surface finishes, and that both the chamber and rifling of small arms components can be formed by swaging.

### Die Design

As must be expected, die shape for swaging is extremely critical and the design illustrated in Figure 13 has been followed as closely as possible. The factors affecting and limiting die design are as follows:

#### Entrance Angle

The angle which the inlet end of the dies makes with the horizontal axis. This has been varied from  $3^{\circ}30'$  to  $5^{\circ}$  depending on the application.

#### Die Radius

The radius of the dies at the throat must be 6 to 8 percent more than the radius of the finished component.

#### Exit Angle

The angle which the exit end of the dies makes with the horizontal axis. This has been varied from  $1^{\circ}30'$  to  $2^{\circ}30'$ .

#### Die Material

Types of steels employed for the dies are listed as follows:

## ANALYSIS

Type	C	Mn	Si	Cr	W	V	Mo
A	0.35	0.30	0.30	3.50	9.00	0.40	---
B	1.00	0.70	0.30	5.25	---	0.25	1.15

### Die Hardness

All dies which have been employed have been heat treated to  $R_c63$ .

### Die Lubrication

The lubrication and cooling of the dies is effected by a flange-mounted pump. This same oil system lubricates the hammers and the rollers. The oil being used is eight parts lubricating to one part cutting oil.

### Mandrel Design

The mandrel, of course, plays a very important part in the operation. First of all, the mandrel determines the internal contour and the mandrel surface determines the surface finish on the inside of the tubular workpiece. The materials which have been used for the mandrels are tool steels which have been heat treated to an average hardness of  $R_c60$ .

### Unique Advantages of Swaging

Advantages derived by the employment of this process are not limited to the close tolerances possible or the fine surface finish which can be obtained. The process holds waste of material to a minimum because metal is displaced instead of cut, and it reduces time on secondary operations to a minimum since only end trimming of parts is involved. Another particular advantage is the fact that the physical properties of material are improved by the cold working. Furthermore, since such a machine can be easily automated for all types of swaging jobs, the

process makes economically feasible the mass production of parts. Finally and perhaps the most significant advantage is the fact that in many instances swaging proves to be the only feasible method of manufacture.

### Cost Comparison

Subsequent to the research and development work executed by the United States Army, several American manufacturers have produced improved versions of the United States Army-designed machine. These machines are now commercially available and some have already been installed at industrial plants. One of these machines is used by an automobile manufacturer for finishing the bore contours of starter motor clutch housings. Several commercial firearms manufacturers in the United States also use the swaging machine.

The operations usually involved in the conventional and the cold-swaging methods are:

#### Conventional

1. Deep hole drilling
2. Ream bore
3. Broach rifle profile
4. Machine chamber
5. Hand ream chamber

#### Cold Swaging

1. Deep hole drilling
2. Counter bore
3. Swaging of chamber and rifle profile

The following cost comparison can be made to show the savings which are possible by using cold swaging instead of the conventional method. The cost information was supplied by a commercial firearms facility which has two machines in operation. The comparison does not include the costs involved in items such as reaming oil, rifle broaching oil, scrap material, etc., since they are not required for the cold-swaging method.

Operation	Conventional Method		Cold Swaging	
	Labor	Tooling	Labor	Tooling
Ream Bore	\$ 3.36	\$24.17	-	-
Broach Rifle Profile	3.46	6.17	-	-
Machine Chamber	3.64	9.88	1.25	1.90
Hand Ream Chamber	3.58	2.37	-	-
Cold Swaging	-	-	3.07	-
Rifle Mandrel	-	-	-	1.40
Chamber Mandrel	-	-	-	4.00
Set of Dies	-	-	-	5.00
Subtotals	\$14.03	\$42.59	\$4.32	\$12.30
Grand Totals	\$56.62		\$16.62	

#### Sub-Fusion temperature bonding

A third area under investigation in recent years is the sub-fusion temperature or solid state bonding process for joining ultra-high-strength materials. Most high-strength materials, particularly alpha and beta type titanium alloys, are susceptible to severe embrittlement when bonded by the more common fusion welding techniques. Since these materials may be adversely affected by the fusion welding, this section covers an engineering study of one such material (a titanium alloy) to determine the feasibility of fabricating large-diameter rocket motor casings by solid state bonding. Preliminary tests were conducted with the titanium alloy selected and subsequently the material was applied to a prototype component since the test results indicated that the solid state bonding process could be employed. This study was executed by the United States Army Materials Research Agency<sup>(8)</sup> in conjunction with two industrial facilities as a joint program.

## Material

The high-strength material selected for the study was Ti-6Al-6V-2Sn alloy which is capable of being heat treated to a minimum (0.1% offset) uniaxial yield strength of 175,000 psi. The supplier's analysis of the material used in the experiment is as follows:

Heat No.	Element (Weight %)									
	C	N <sub>2</sub>	C <sub>2</sub>	Al	Sn	Fe	V	H	Cu	Ti
D-2001*	0.027	0.022	0.19	5.4	2.0	0.72	5.7	0.0045	0.68	Remainder
D-2003**	0.025	0.026	0.17	5.5	2.0	0.73	5.4	0.0035	0.67	Remainder

\*D-2001 was used to form hemispherical end closures

\*\*D-2003 was used to form cylindrical center sections

## Preliminary Heat-Treatment Tests

In order to determine the most suitable heat treatment for the completed prototype component, specimens of the material were subjected to two different heat treatments as shown in Table I along with the resulting mechanical properties:

TABLE I HEAT TREATMENT TEST DATA

Heat	Heat Treatment*		Y. S. 0.1% (ksi)	T. S. (ksi)	Elong. (%)	R. A. (%)	Charpy V-Notch Impact Energy at -40 F (ft-lb)
	Solution Temp.	Aging Temp.					
2003	1630	1150	178.5	190.0	6.0	9.2	6.0
		1 hr	4 hr	179.0	190.5	9.0	15.5
2001	WQ	AC	177.0	186.0	5.5	10.6	6.7
				176.0	185.0	5.0	9.9
2003	1580	1100	181.5	192.0	5.5	12.2	6.4
		1 hr	4 hr	180.0	191.0	7.0	13.3
2001	WQ	AC	177.5	187.5	8.5	19.4	7.0
				175.0	186.0	6.0	9.9

\*WQ = water quenched; AC = air cooled

Standard 0.252-inch-diameter tensile specimens (MIL-T.46038)

Standard 0.394-inch-square Charpy V-notch impact specimens (MIL-T-46038)

Preliminary Bond Evaluation Tests

Preparatory to fabricating the component, it was deemed necessary to conduct a number of experiments to establish the processing schedules for the actual forming operation and to conduct mechanical testing of the joint. The processing variables included (1) joint configuration; (2) surface finish; (3) heating media (oxyacetylene gas pressures); (4) loading pressures and cycle; (5) bonding time; and (6) degree of upset (hot gather). Tests were conducted on a test specimen, as shown in Figure 14, of similar configuration to the final component. The results of mechanical testing are contained in Table II, as received from the supplier.

TABLE II MECHANICAL TEST DATA

Specimen	Specimen		Ultimate			
	Diameter (in.)	Area (sq in.)	Load (lb)	T. S. (ksi)	Elong.* (%)	R. A. (%)
1	0.2490	0.0487	8080	165.9	16	32.2
2	0.2505	0.0493	8240	167.1	15	31.0
3	0.2505	0.0493	8220	166.7	14	24.3
4	0.2505	0.0493	8040	163.1	14	29.8
5	0.2505	0.0493	8080	163.9	14	28.4
6	0.2505	0.0493	8020	162.7	14	29.0
7	0.2505	0.0493	8120	164.7	14	29.0
8	0.2505	0.0493	8100	164.3	15	29.0
9	0.2505	0.0493	8120	164.7	13	27.8
10	0.2490	0.0487	8100	166.3	11	19.1
11	0.2500	0.0491	8140	165.8	13	28.1
12	0.2495	0.0489	8200	167.7	12	30.5
Average				165.2	13.75	28.2

\*0.5-inch gage length.

Standard 0.252-inch-diameter tensile specimens (see MIL-T.46038). All specimens were taken perpendicular to bonded interface.

Prototype Component Fabrication

After the preliminary tests were completed, fabrication of the prototype component proceeded. A cross-section view of the 22-inch-diameter cylinder is shown

in Figure 15. The end closure portions of the casing were hot hammer forged and the cylindrical center section was hot ring rolled. Prior to the joining operations, the cylindrical and the end closure sections were machined using accepted techniques for machining of titanium. The first step in the bonding operation consisted of placing one end closure and the center cylindrical section in the horizontal pressure bonding equipment shown in Figure 16. Joint interfaces were cleaned with ether and the components were butted together with the use of a force applied through the end closure and cylinder shoulders. The inside surfaces were protected from surface oxidation by means of purging gas. The joint was heated with an oxyacetylene flame ring to a temperature of approximately 1650 F in about 2 minutes. Figure 17 shows solid state bonded motor casing indicating pertinent items. A bonding pressure of 8000 psi was applied simultaneously with the heat, and plastic flow occurred as the preselected temperature was approached. The pressure was then dropped to 4000 psi and the bonding action was completed.

In order to bond the other end closure to the assembly, a similar cycle was repeated and a suitable bonding was effected. After bonding, the fabricated case was aged at 1100 F for one hour, followed by an air cool. Surfaces were finished by machining to the required dimensions indicated in Figure 15.

The fabricated case was then subjected to hydrostatic pressure and the test results were satisfactory. Final product is shown in Figure 18.

These experiments demonstrated that fabrication of large-diameter rocket motor casings by solid state bonding is feasible. It further demonstrates that with the use of such a process, high-strength alloys could be used with greater reliability by eliminating the adverse effects encountered in common fusion welding. In the particular case investigated, it would be impossible to fabricate the component by any other known method and, therefore, this process represents a new and economical industrial capability.

#### High energy rate forging

A fourth area of interest which the United States Army has been investigating<sup>(9)</sup> is the application of high energy to the forming of metals, ceramics, and other component materials. Here again, this new process was selected for investigation because it offers production and economic advantages.

This particular process consists of a metalworking machine that applies high rates of energy to materials by means of a pneumatic hydraulic system. The

energy source consists of an accumulator with stored high pressure gases which can be released practically instantaneously to actuate a piston that carries tooling to do useful work in compacting, forging, or extruding. The compressed gas drives the working piston at very high velocities.

### Machine Tool

The high energy rate forging machine employed for the investigation discussed here is shown in Figure 19. This machine is one of several models developed and marketed by a commercial facility.

This forging process has two major systems: first, a power source or energy-producing section, and second, a reaction system to absorb the high forces that can be produced. A better explanation of how the process works can be given by describing the schematic shown in Figure 20. The driving section or power source consists of a simple cylinder divided into two chambers by means of an orifice plate (Figure 20). Riding in the lower portion of this cylinder (Chamber B) is a piston which carries the working tooling. This piston carries a sliding seal that acts on the inner wall of the cylinder portion of Chamber B. Attached to the upper face of the piston is a resilient seal.

To facilitate explanation of the operational features of this process, let it be assumed that the cylinder has an inside diameter of 3.5 inches and that the orifice plate has a hole 1 inch in diameter. Thus the cross-sectional area of the cylinder and the orifice would be approximately 10 square inches and 1 square inch, respectively. If Chamber B is pressurized with gas to 200 psi, neglecting the area of the ram, a net force of 2000 pounds is generated on the lower face of the piston. This force causes the piston to seal tightly against the orifice plate. Chamber A can now be pressurized to 2000 psi without causing movement of the piston assembly. In the ready position, the 2000 psi pressure acts on the exposed piston area of approximately 1 square inch. The system is now in equilibrium. If the pressure in Chamber A is increased slightly, a net force is generated against the piston causing it to move away from the orifice plate.

A slight displacement allows the 2000 psi pressure of Chamber A to act over the entire upper face of the piston, thereby producing a propelling force of 20,000 pounds in less than one millisecond. This propelling force, applied to the piston, produces instantaneous velocities of several hundred inches per second.

The piston is returned to its original firing position by pumping high pres-



sure oil into Chamber B, forcing the high pressure gas back into Chamber A, and reseating the upper face of the piston against the orifice plate. After the seal is made, the oil is bled from the system and low pressure gas (200 psi) maintains the piston in position; the system is again in equilibrium awaiting the next firing cycle.

The reaction system, essentially a simple combination hydraulic and pneumatic recoil mechanism, is required to compensate for the high forces that are produced. This system consists of two pistons attached to the tie rods of the frame riding in a cylinder section as shown in Figure 20. The recoil mechanism tends to maintain the machine in a predetermined position.

### Application

Typical of the applications under investigation at the U. S. Army Materials Research Agency is the forming of a prototype component for the "Redeye" high-explosive case shown in Figure 21. To determine the feasibility of producing the component by the high energy rate process, experimental quantities were fabricated. The component is currently being formed by conventional upset forging techniques.

The forgings made by the high energy rate process were formed from 6Al-4V titanium alloy billets (2.830 inches in diameter and 1.750 inches in length) heated in air and forged from a temperature of 1750 F utilizing a fire pressure of 1000 psi. This pressure corresponds to an energy level of approximately 57,100 foot-pounds. A stroke of 10 inches was held constant for all forgings. A water-graphite mixture applied to the punch and die by means of a spray gun was used as a lubricant.

### Tooling

To carry out the feasibility studies and at the same time have appropriate tooling for other types of research programs, a set of universal tooling was obtained. It was designed to allow for maximum versatility and can be used for closed cavity extrusion molding, forward extrusion, and forging of small components by interchanging the various die sections. The universal die holder is shown in Fig. 22.

A set of forging tools was designed and fabricated to form the component for the Redeye high-explosive case. The design of the die used in conjunction with the set of universal tooling incorporated a threaded section within the die cavity (see Figure 23) into which the forged material would flow and thereby lock itself within the die. This arrangement made it possible to strip the forging from the punch upon retraction of the ram. The forging (Figure 24) was then unscrewed from the cavity by means of a special tool designed to fit the two projections at the rim of the forged cup. These two projections are formed at the time the component is forged by means of depressions at the shoulder of the punch shown in Figure 25.

### Cost Comparison

The following cost comparison can be made to show the savings which are possible by replacing the conventional upset forging method by the high energy rate process.

Items	Conventional Method	High Energy Rate Method
Forging Operation	\$ 48.00	\$ 96.00
Starting Workpiece	834.00	588.00
Totals	\$882.00	\$684.00
Savings per 100 units		\$198.00

The difference in the cost of the starting workpiece is based on the fact that 2.78 pounds of material are required for each item when produced by the conventional method and only 1.96 pounds are required per item for the high energy rate process. The cost of the titanium alloy for the comparison was assumed to be \$3.00 per pound.

The difference in the cost of forging is based on the fact that two operators are required for the high energy rate process, whereas only one operator is required for the conventional upset forging method.

## **Advantages**

Advantages which can be derived from the employment of the high energy rate forming process are not limited to material savings. This process also offers economic benefits in the production of better parts with smoother finishes and finer grain structures. For some applications, this process enables the part to be forged in one operation, thereby reducing the time and tooling costs involved in secondary operations. Another particular advantage is the fact that even the most difficult refractory metals have proved malleable when subjected to the high velocity rates generated by this process. Finally, high energy rate forming provides an additional fabrication technique for the design engineer's consideration.

## **Metal removal**

The last area of interest discussed here is the removal of metal at high velocity utilizing advanced ceramic cutting tool materials.

The critical supply of the materials commonly used for metal-cutting tools has always played an important role during periods of emergency. Difficulties in procuring tungsten carbide and high-speed tools during emergency periods indicated that it was mandatory to obtain a satisfactory nonstrategic cutting tool. Hard ceramic materials are available in abundant supply and can be used in place of tungsten carbide cutting tools and high-speed steel tools for some applications.

In view of the foregoing, the United States Army Materials Research Agency has been engaged in recent years in a continuing program designed for the advancement of the ceramic cutting tool in this country. The program has been carried out as a joint program between the United States Government, industry, and universities. Therefore, the following review of ceramic tools represents the result of a joint effort rather than the test results of any of the numerous projects carried on or sponsored by the United States Army.

## **Ceramic Tool Manufacture**

At the present time, all ceramic cutting tools being produced in quantity

are manufactures from aluminum oxide.

The current methods of ceramic tool manufacturing are the cold-pressed and hot-pressed techniques. The cold-pressed technique consists of forming the powdered alumina under pressures of 40 to 60 ksi followed by sintering in an atmosphere-controlled furnace at temperatures of 1700 to 1950 F. The second technique consists of simultaneously applying heat and high pressure to the alumina powder in a graphite crucible or mold. The second is more expensive but it produces a cutting tool with better physical properties. In both techniques, grain growth inhibitors are added to avoid excessive grain growth which embrittles the material.

At this Agency all evaluation studies have been conducted on a 2-1/2-inch turret lathe equipped with a dynamometer and recording instrumentation as shown in Figure 26. This turret lathe has a maximum rotational speed of 2000 rpm actuated by a 35-hp drive motor, and is equipped with variable speed control. Speeds of approximately 3500 surface feet per minute can be obtained if a work-piece of suitable diameter is employed. Other cooperating facilities conducted engineering studies under simulated or actual production conditions and attained machining speeds of 7000 surface feet per minute. The ceramic test results generated with this Agency's machine, coupled with the test results from other laboratories, have improved the status of ceramic tools.

### Tool Design

The most common type of ceramic tool is the disposable insert type (see Figure 27) which is produced in square, triangular, and circular shapes. The negative rake angle is generally preferred because the negative rake blank offers six to eight cutting edges, according to its particular shape. The positive rake square blank presents four cutting edges, and would, therefore, seem less economical.

A narrow negative land honed on the edge of the tool decreased the tendency of the tip to shear off. The nose radius should be as large as possible but small enough to prevent dangerous chatter and vibrations which shorten tool life.

## **Machining Test Results**

Ceramics have proven successful in machining all materials except for certain high-temperature steels such as the high nickel alloys, and certain light metals such as aluminum and titanium. The high-temperature steels appear to be too hard and abrasive to machine effectively. The reason for the difficulty in machining light metals has not been clearly established by investigators.

There is very little tendency for "built-up edge" to develop in ceramic cutting because there is less material adhesion than with other tool materials. The appearance of the chips produced in ceramic operations (see Figure 28) is different from that of chips produced by other cutting tool materials.

Excellent workpiece surface finishes can be produced, particularly in the high-speed range. Workpiece and cutting tool remain cool provided the chip breaker is adjusted properly. Coolant is not generally used during machining.

Ceramic tool failure occurs either by a sudden catastrophic fracture of a large portion of the tool or by a wearing away of small particles. However, it must be pointed out that vibrations and interrupted cutting have deleterious effects on ceramic cutting-tool life. Under certain machining conditions, ceramics can perform at cutting speeds at least 100 percent greater than those used with carbides.

## **Production Problems**

Although considerable experimentation has been carried out by industry, universities, and the United States Government, and ceramic tools have been tried on a number of machining applications, there are several problems which are currently inhibiting the universal use of ceramics in production application. One of these problems is the fact that specially trained operators are required for the successful application of ceramic tools. Another problem is directly related to machine tool requirements which are mandatory for attaining maximum efficiency in the utilization of ceramic cutting tools. In high-velocity machining, the speed of the machine must be correlated with adequate power supply. There is indicated a need for specially designed machine tools to take advantage of ceramic cutting tool techniques. Therefore, manufacturers who have decided to utilize ceramic cutting tools have had to make homemade additions to standard machine tools. Because of this, the production advantages gained from ultra-high machining speeds have been sacrificed.

Finally, the most important problem is that of economics. The cost of ceramic tools is at least twice that of high-grade carbides. Furthermore, ceramic tools with their negative rake angles and the higher speeds utilized in ceramic tool cutting require increased power consumption, resulting in higher costs.

### **Advantages**

Ceramic cutting tools offer the following advantages:

1. Ceramic materials are readily available
2. Ceramic tools have a longer life due to high hardness at both room temperature and elevated temperature
3. Machining can be carried out at higher speeds thus decreasing machining time
4. No built-up edge is generated
5. Finish of workpiece is improved

### **General Remarks**

Increased usage of ceramic tools is dependent on (a) greater familiarization by the tooling engineers, (b) specific application, (c) availability of adequate machine tools, and (d) economic consideration.

In the event of shortages of the more commonly employed cutting tool materials, ceramic tools will serve as a substitute material regardless of economic considerations.

## Summary

As stated in the introduction, the areas of interest covered in this paper represent only a sample of the current United States Army Materials Research Agency programs.

The casting studies conducted to date indicate that even greater effort must be expended to obtain a more fundamental understanding of the variables associated with solidification. There is a need for advanced castings technology but this cannot be done without basic data. Therefore, current United States Army programs are oriented toward materials research.

The rifling of barrels by swaging promises to become an acceptable process after the current experimental techniques are perfected and the pilot plant studies are completed. Rifling now produced by broaching will show substantial cost savings when produced by swaging. Furthermore, the new technique will provide the design engineers more latitude since such a machine tool will make inner contours unobtainable by other methods.

The sub-fusion temperature bonding experiments have demonstrated that in some cases advanced technology makes it possible to successfully employ certain materials such as the high-strength titanium alloy used to fabricate rocket motor casings. Employment of the solid state bonding process eliminated the adverse effects encountered in common fusion welding. In fact, the prototype component under investigation would have been impossible to fabricate by any other known method.

The high energy rate application studies conducted to date, although limited in quantity, indicate that such a method of forming opens new design possibilities since the process offers versatile production capabilities. The process can be used to forge, extrude, compact, upset, or perform any similar forming operation. Furthermore, advantages which can be derived by utilizing the high energy rate forging process include better parts, smoother finishes, less metal loss, and simpler tooling. Another particular advantage is the fact that the technique makes it possible to process refractory metals which are difficult to form.

Finally, the work in ceramic cutting tools carried out at the United States Army Materials Research Agency has stimulated considerable interest in the ceramic cutting tool industry in this country. The work continues but its full acceptance still has many obstacles. There is a need for educational programs before ceramic tools can be fully incorporated in the production line. Furthermore, the development of more adequate machine tools is essential. Availability of specially trained personnel and improved machine tools should increase the use

of ceramics.

The selected areas covered in this paper confirm that research is essential. Continuing materials research will advance the technology necessary to develop optimum materials for economical application of military components.



## REFERENCES

1. AHEARN, P.J., LANGE, E., and LANGENHEIM, A. Proposed Outline of Department of Defense Program on High Strength Steel Castings, 1959.
2. CARBONARO, P.A.G., and AHEARN, P.J. High Strength Steel Castings, Their Future in Army Materiel, SAE Paper 655B, Jan 1963.
3. ZOTOS, J. Significance of Reduced Phosphorus and Sulfur Content on the Ductility and Toughness of Cast Low Alloy Steels. Transactions, American Foundrymen's Society, v.67, 1959, p. 698-704.
4. COLLING, D.A., and AHEARN, P.J. Desulfurization of Cast Steel by Calcium Inoculation, Journal of the Iron and Steel Institute, London, England, v.200, March 1962, p.211-216.
5. GARLICK, R.G., and WALLACE, J.F., Grain Refinement of Solidifying Metals by Vibration, Transactions, American Foundrymen's Society, v.67, p.366-374. 1959.
6. MASSACHUSETTS INSTITUTE OF TECHNOLOGY Investigation of Solidification of High-Strength Steel Castings. Contract DA-19-020-ORD-5443. Interim Summary Report, February 1962.
7. COLLING, D.A., AHEARN, P.J., and LEMINGS, M.C. Effect of Solidification Variables on Mechanical Properties of Cast Steel, Watertown Arsenal Laboratories, WAL TR 311.1/1, July 1962; also Transactions, American Foundrymen's Society, v.70, 1962, p.1083-1094.
8. FITZPATRICK, R., COLTON, R.M., and RIZZITANO, F.J. Solid State Bonding of Prototype Titanium Rocket Motor Casings, (Work in process).
9. GAGNE, ROGER A. High Energy Rate Forging of Ti-6Al-4V Alloy. Work in process at U.S. Army Materials Research Agency.

BIBLIOGRAPHY

- AYVAZIAN, A., and VALENCIA, S. Study and Application of New Manufacturing Methods. Watertown Arsenal Interim Technical Report, RPL 31-6, May 1957.
- BARNES, G.W. Selecting Ceramic Cutting Tools. Metalworking, June 1961, p. 15-17.
- CARBONARO, P.A.G., and VALENCIA, S. Precision Forming Techniques - Cold Swaging. ASTME Technical Paper 290, v.60, Book 1, 1960.
- COLTON, R.M. The Effects of Fabrication Procedure on Properties of Ti-6Al-6V-2Sn-0.5Fe-0.25Cu. Abstract of Technical Presentation given at New York University Fifth Titanium Metallurgy Conference, 14-15 September 1959; Watertown Arsenal Laboratories Monograph Series, WAL MS-8.
- KENNEDY, W.B. Ceramics for Metal Cutting. Watertown Arsenal Report, TPR 80/7, 1956.
- KENNEDY, W.B. Experimental Machining with Ceramics. ASTE Paper No. 25, v.57, 1957.
- McNAMARA, HAROLD B., and NACINOVICH, T. Review of Status of Ceramic Tools. U.S. Army Materials Research Agency Monograph Series, AMRA MS 63-08, December 1963.
- MENNEL, R. Economic Analysis for Turning with Ceramic Tools. Watertown Arsenal Report, RPL 23/11, December 1959.
- OTTESTAD, J.B. "Dynapak" (A High Energy Rate Machine Tool), presented at the 40th Metal Congress, Cleveland, Ohio.
- ROMINS, H.E. Fracture Toughness Study of Ti-6Al-6V-2Sn Titanium Alloy Sheet 0.1-Inch Thick for Possible Application in the Construction of Welded Solid-Propellant Rocket Motor Cases. U.S. Naval Weapons Lab., Dahlgren, Virginia, NWL Report 1839.

SHAW, M. C., and SMITH, P. A. Tests Compare Finishes from Ceramic and Carbide Tools. *The Tool Engineer*, v.38, April 1957, p.97.

VALENCIA, S. Swaging: Should You Pick this New Method for Inside Jobs. *Metalworking*, September 1959, p.79-81.

VALENCIA, S. The Swaging Process. *Ordnance*, March-April 1960, p.806-807.

Minutes of Symposium on Ceramic Cutting Tools. Symposium held at Watertown Arsenal, Watertown, Massachusetts, 9 February 1955.

The Ti-6Al-6V-2Sn-0.5Fe-0.25Cu Alloy and Other Alpha-Beta Type Alloys Utilized at Watertown Arsenal. Abstract of Technical Presentation given at New York University at the Sixth Titanium Metals Conference, 12-13 September 1960; Watertown Arsenal Laboratories Monograph Series, WAL MS 21.

Titanium Alloys for Critical Ordnance Components. Watertown Arsenal Laboratories Monograph Series, WAL MS-18, April 1960.

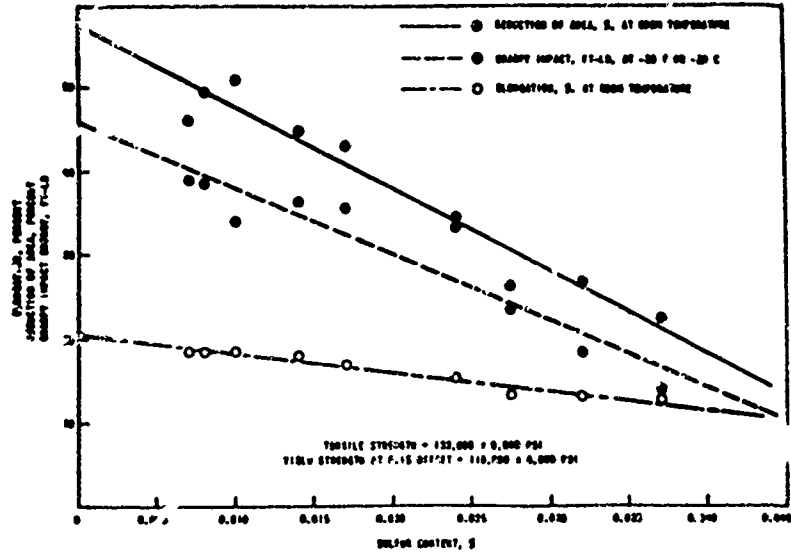

Fig. 1 Effect of Sulfur Content on Mechanical Properties of Cast High Nickel 4325 Steels (After Zotos)

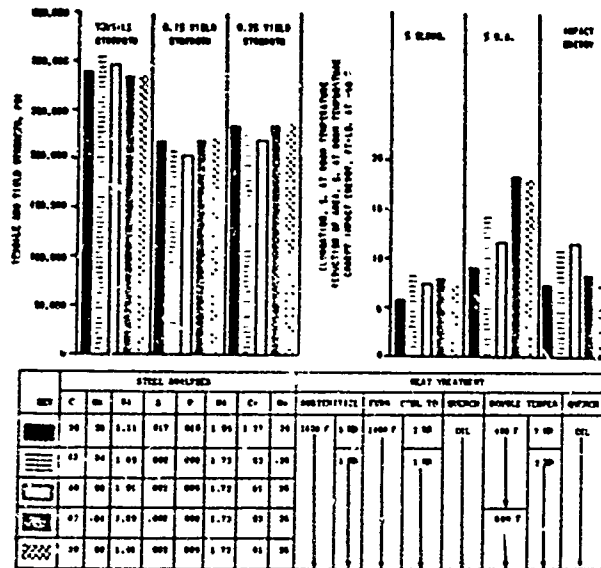

Fig. 2 Effect of Sulfur Content on the Ductility and Toughness of High Strength Steel Castings (After Colling and Ahearn)



Fig. 3 Typical Macrostructure of Experimental Casting Cross Section

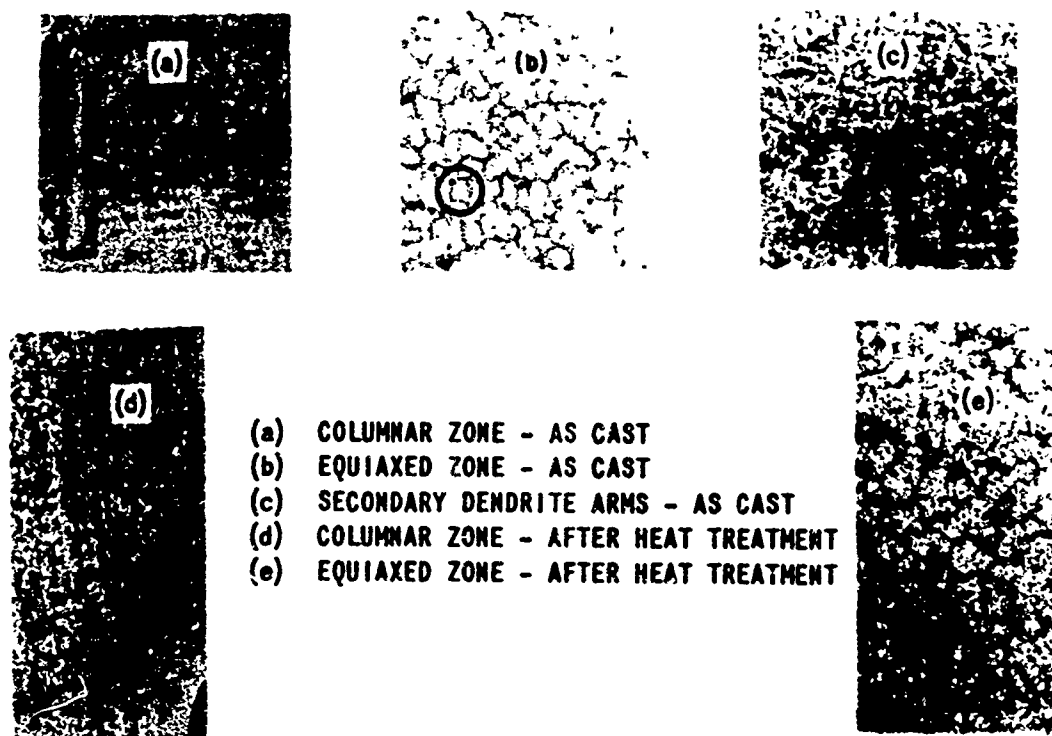

Fig. 4 Metallographic Specimens Used for Microsegregation Studies. Microanalysis is Limited to Enclosed Areas of Photomicrographs. Magnification: 6X as Cast

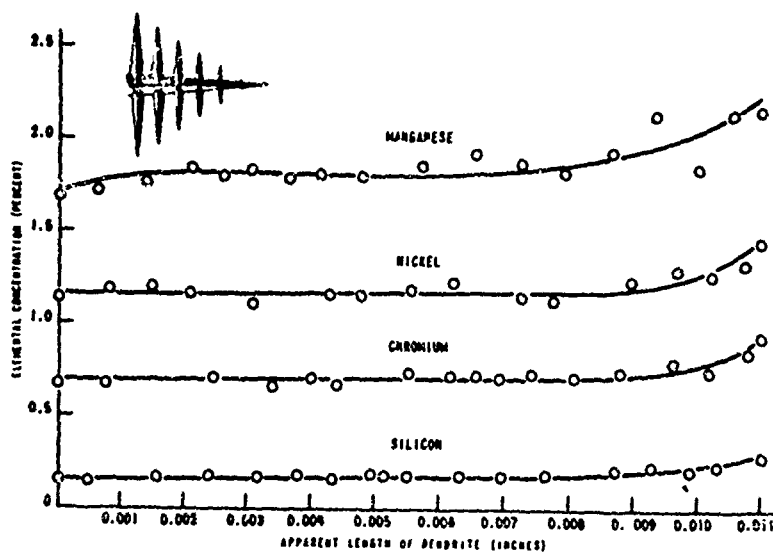

Fig. 5 Microsegregation Along a Dendritic Spine in the Columnar Zone - As Cast (After Colling Ahearn and Flemings)

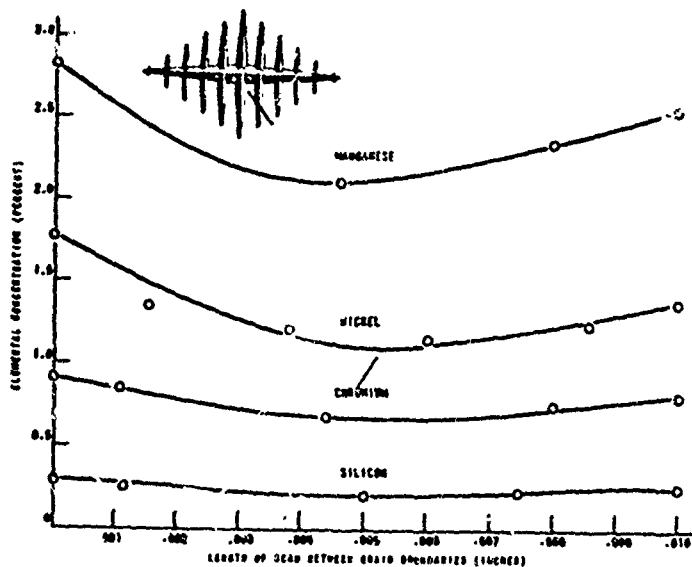

Fig. 6 Microsegregation Across a Primary Arm of an Equiaxed Dendrite - As Cast (After Colling, Ahearn and Flemings)

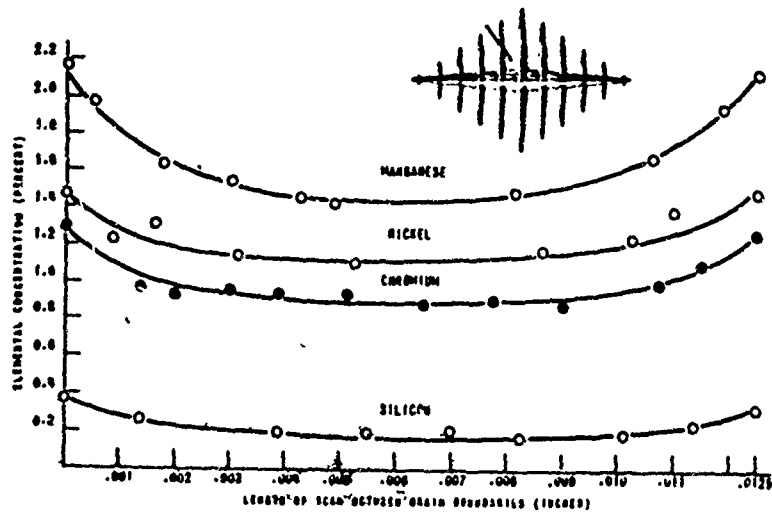

Fig. 7 Microsegregation Across a Primary Arm of an Equiaxed Dendrite - After Heat Treatment (After Colling, Ahearn and Flemings)

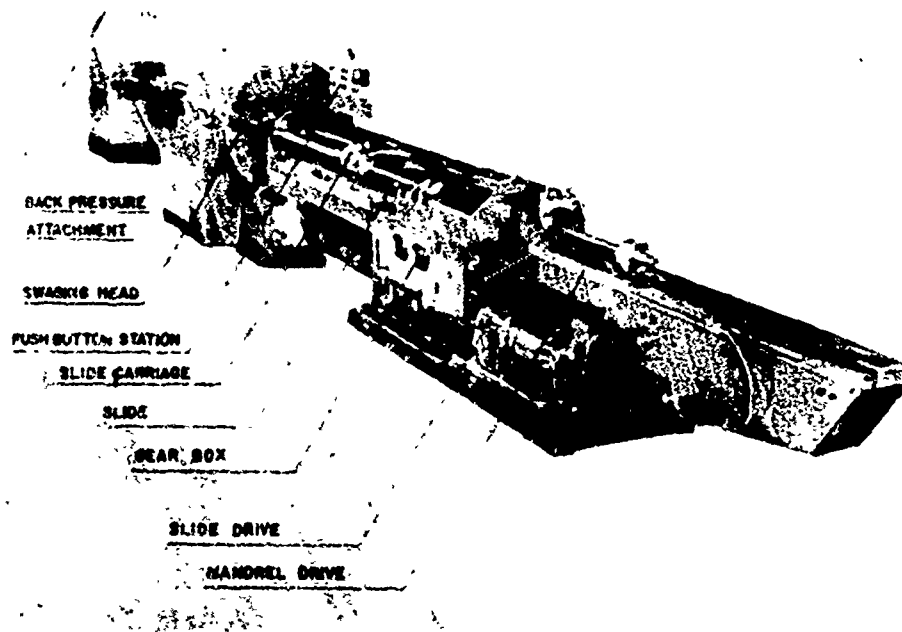

Fig. 8 Cold Swaging Machine - 200-Ton Capacity

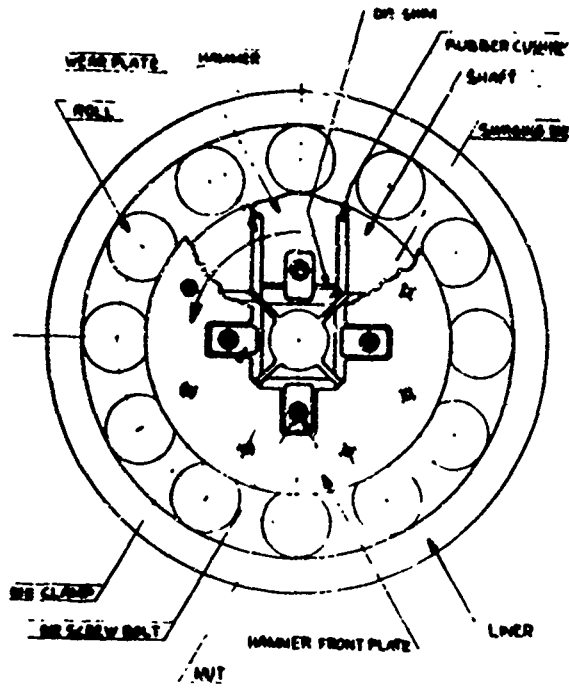

Fig. 9 Head with Hammers in Closed Position

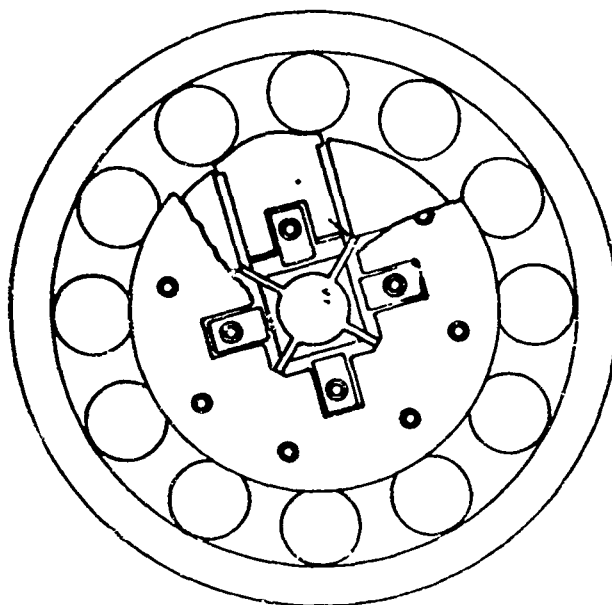

Fig. 10 Head with Hammers in Open Position



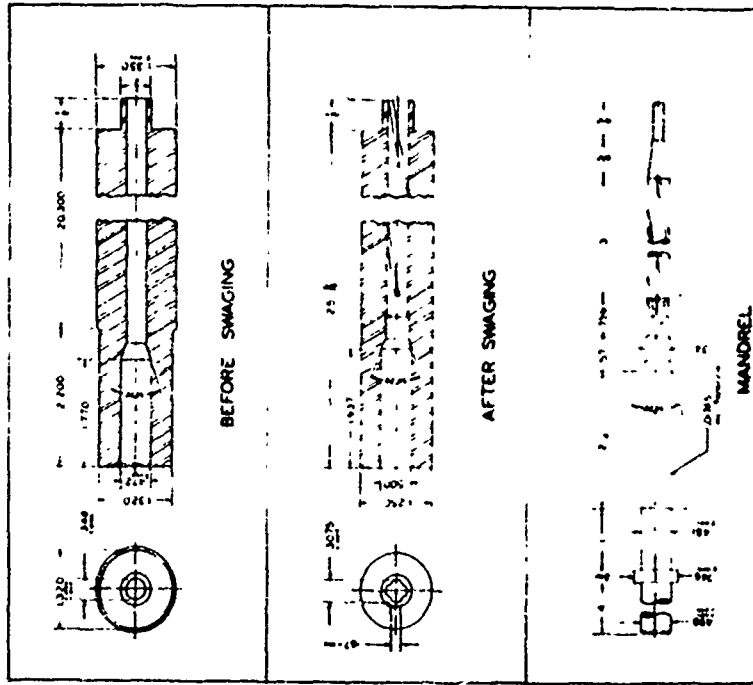

Fig. 12 Rifle Barrel, .30 Caliber - Chamber and Rifling

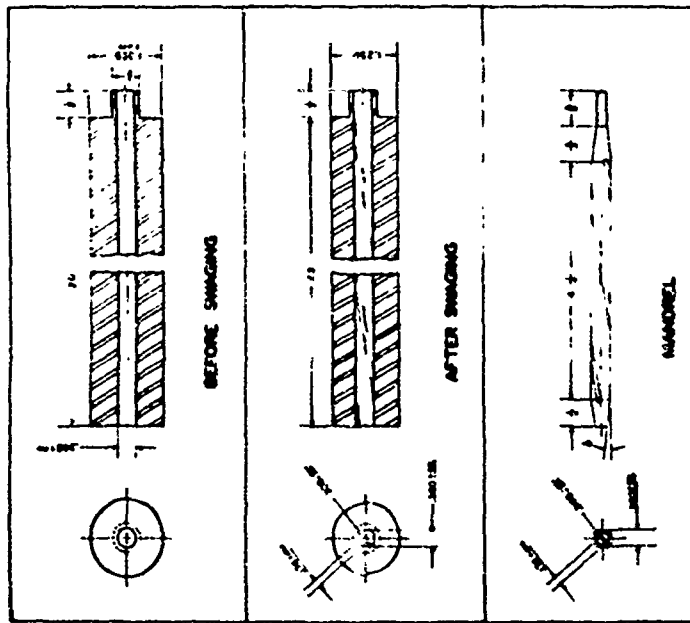

Fig. 11 Rifle Barrel, .30 Caliber - Rifling

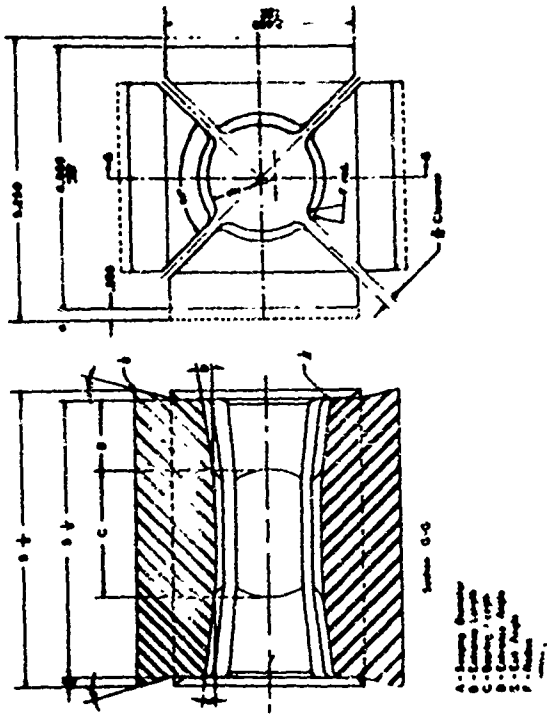

Fig. 13 Swaging Dies

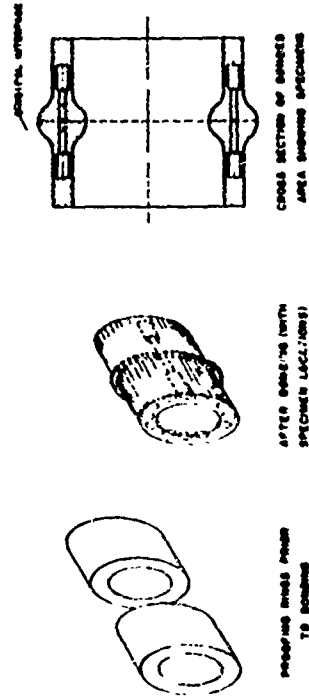
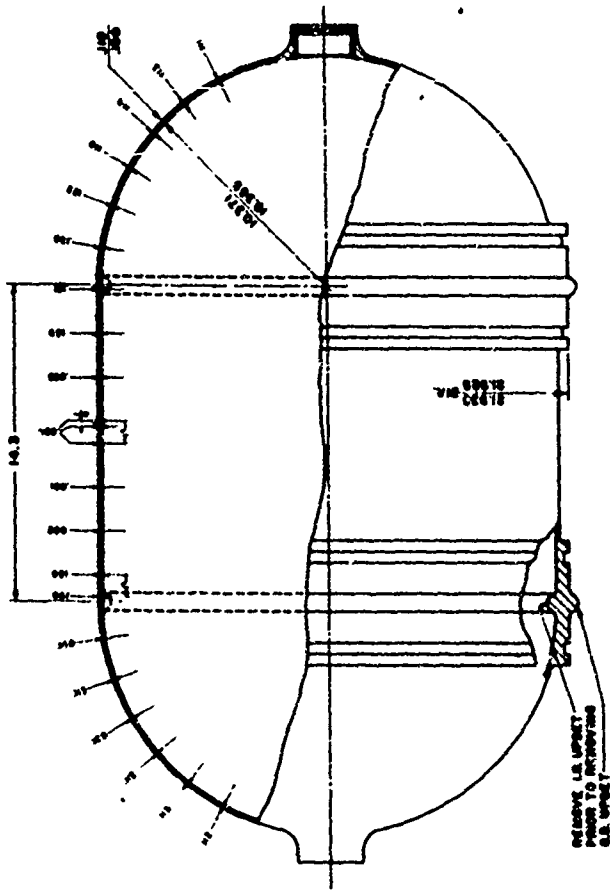

Fig. 14 Solid State Bonding Proof Testing



SEE ALL DIMENSIONS IN PARAGRAPHS 1 AND 2 OF DRAWING

Fig. 15 Solid State Bonded Motor Casing - Joint Location and Wall Thicknesses

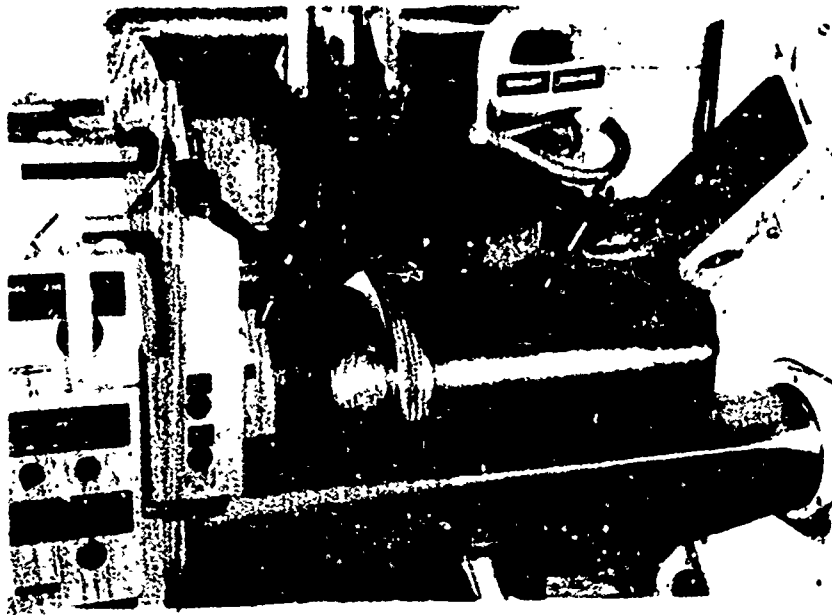

Fig. 16 Pressure Bonding Apparatus - During Bonding

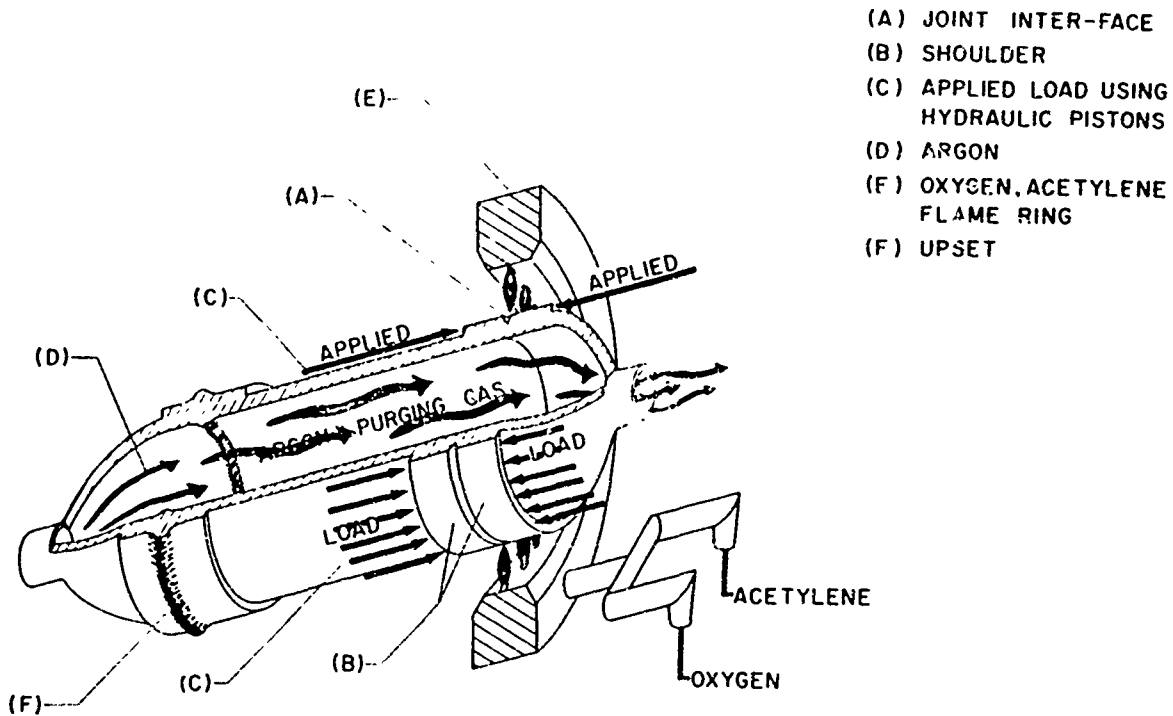

Fig. 17 Solid State Bonded Motor Casing - Bonding Procedure

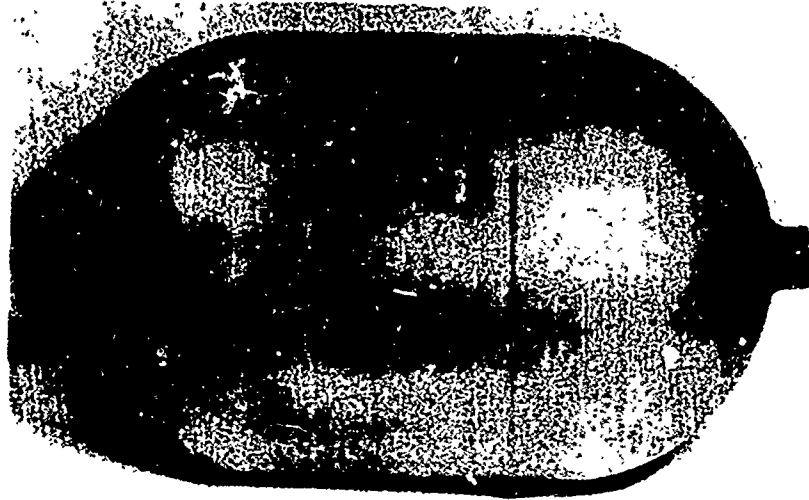

Fig. 18 Pressure - Bonded Casing - Machined



DTIC AF 80761 1230

Fig. 19 High Energy Rate Forging Machine

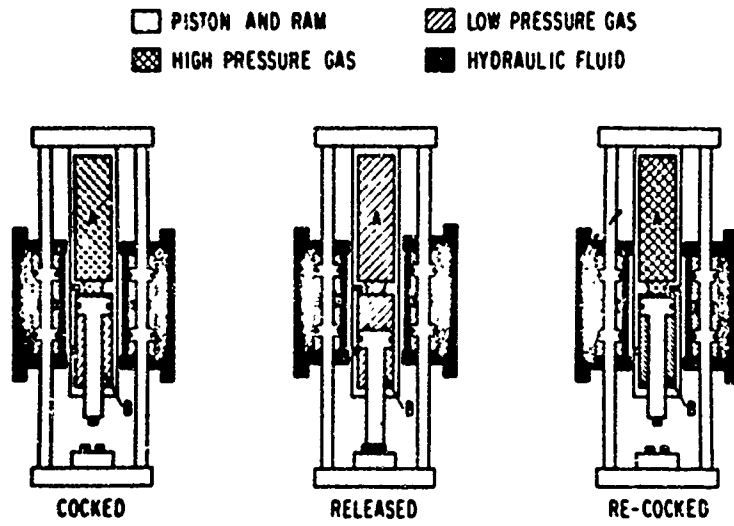

Fig. 20 High Energy Rate Forging Process

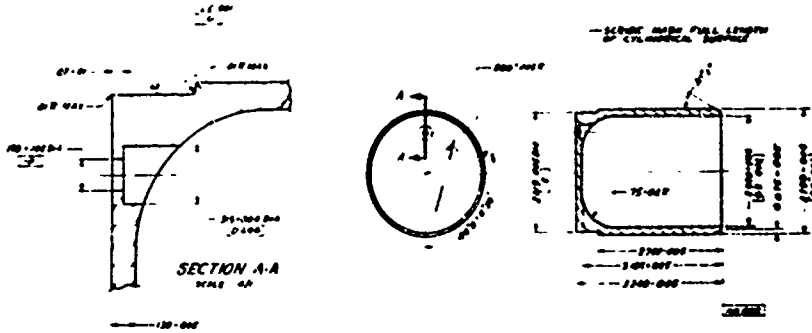

Fig. 21 Redeye High - Explosive Case

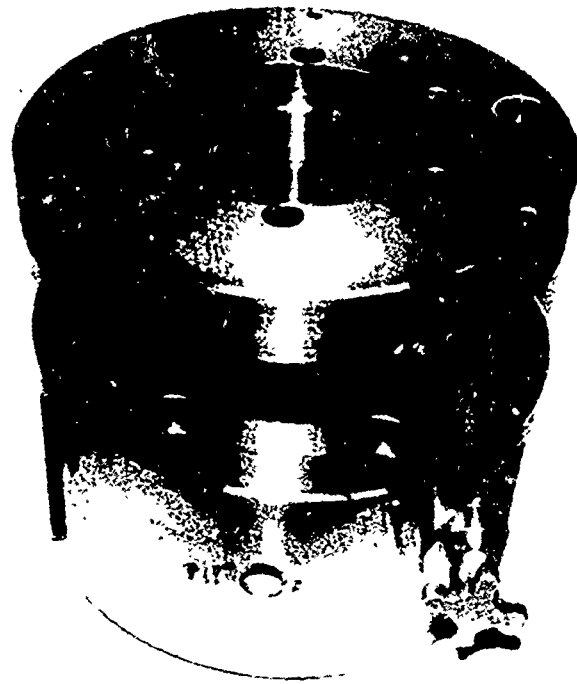

Fig. 22 Universal Die Holder and Stripper

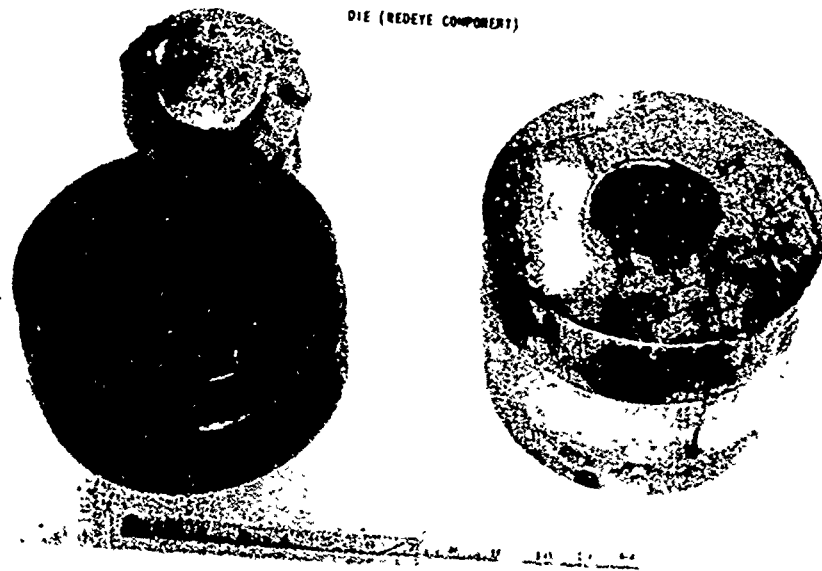

Fig. 23 Redeye Component

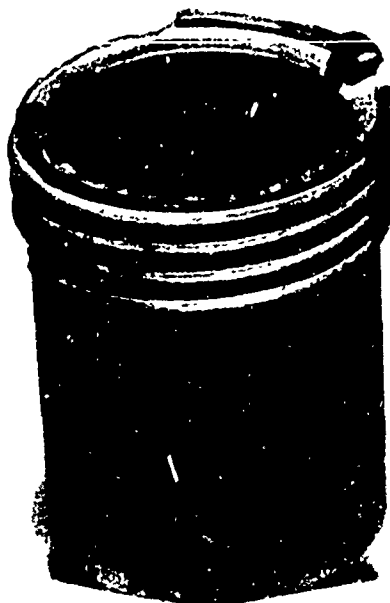

Fig. 24 Redeye Component Forged from GAP-4V-Ti Alloy



Fig. 25 Punch - Redeye Component

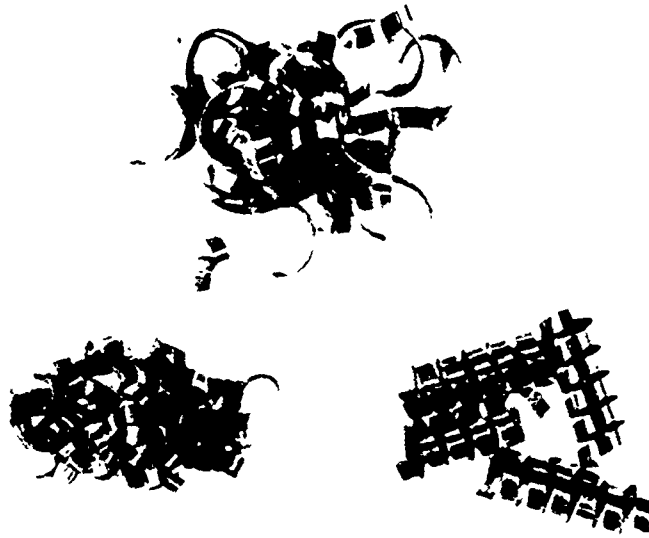

Fig. 26 Machine Tool



Fig. 27 Typical Tool - Holder for Throw-Away Carbide or Ceramic Blanks





**Fig. 28**      **Chips Produced with Ceramic Cutting Tools**

A PRODUÇÃO DE ELETRODOS GIRANTES PARA SOLDAGEM  
EM LIGA COBRE-COBALTO-SILÍCIO(\*)

Sérgio Augusto de Souza (\*\*)  
Luiz C. Correa da Silva (\*\*\*)

**RESUMO** - O trabalho relata a experiência da Divisão de Metalurgia do Instituto de Pesquisas Tecnológicas de São Paulo na produção de eletrodos girantes em liga cobre-cobalto-silício, para utilização em máquinas de soldar. Os trabalhos realizados no I. P. T. visaram atender, no possível, as necessidades da indústria local e evitar a total dependência de importações. Apresenta-se um resumo dos principais fatos e dados referentes aos eletrodos para máquinas de soldar. Descreve-se: a técnica de fundição dos anéis; o método de dimensionamento dos mesmos para conveniente forjamento posterior; a técnica de forjamento empregada e a execução dos tratamentos térmicos necessários. São apresentadas macro e micrografias visando ilustrar a estrutura dos eletrodos fundidos e forjados e dos eletrodos fundidos, forjados e tratados termicamente.

---

(\*) Contribuição Técnica apresentada ao XIX Congresso Anual da Associação Brasileira de Metais; São Paulo, julho de 1964.

(\*\*) Membro da ABM, Engenheiro Responsável pela Seção de Ligas Não-Ferrosas do Instituto de Pesquisas Tecnológicas.

(\*\*\*) Membro da ABM, Chefe da Divisão de Metalurgia do Instituto de Pesquisas Tecnológicas; Professor de Siderurgia da Escola Politécnica da U. S. P.

## 1. INTRODUÇÃO

A Secção de Ligas Não-Ferrosas do Instituto de Pesquisas Tecnológicas tem recebido, frequentemente, pedidos para confecção de anéis em liga de cobre de alta condutividade para serem usados como eletrodos girantes. Os pedidos variam quanto ao tamanho dos mesmos e quanto a liga, que pode ser de cobre-cromo, cobre-níquel-silício, cobre-cromo-silício ou cobre-cobalto-silício. Atualmente a primeira e a última das ligas mencionadas estão sendo preferidas, principalmente a liga cobre-cobalto-silício, que é objeto deste trabalho.

A princípio, para atender os Interessados, o processo usado era o de se fundir simplesmente as peças e entregá-las no estado bruto de fusão, para que aqueles fizessem os tratamentos térmicos necessários. Algumas peças apresentavam defeitos de fundição, tais como: bolhas, porosidades, inclusões de escória, trincas, sendo então decidido mudar-se o processo de confecção dos anéis, passando-se a forjá-los, depois de fundidos convenientemente. Devido ao caráter especial deste processo, relata-se aqui o estudo relativo às condições de fundição e de forjamento desses anéis.

## 2. CARACTERÍSTICAS DESEJÁVEIS PARA OS ELETRODOS

Um eletrodo girante para solda elétrica contínua de tubos, aplicação principal destes anéis, deve apresentar as seguintes propriedades<sup>(1)(2)</sup>:

- a. Dureza elevada, entre 120 e 200 Brinell.
- b. Dureza elevada mesmo a altas temperaturas.
- c. Condutibilidade elétrica e térmica elevadas.
- d. Boa resistência mecânica.
- e. Reduzida tendência de se fundir com as peças a serem soldadas. A isto, deve-se o grande desgaste a que o anel fica sujeito durante o seu uso.

### 3. TÉCNICA UTILIZADA NAS EXPERIÊNCIAS REALIZADAS

A técnica utilizada consistiu nas seguintes operações: fundição dos anéis em areia, seguindo-se a rebarbação e forjamento desses anéis fundidos até as dimensões desejadas, de tal modo a garantir cerca de 50% de redução na espessura; por fim, seguiram-se os tratamentos térmicos necessários.

No forjamento há naturalmente, uma variação dimensional de difícil previsão, sendo necessário estudá-la no decorrer da operação. Para facilitar o estudo fundiu-se um anel menor que os que se tem feito habitualmente, mas cujas dimensões guardaram as mesmas proporções dimensionais que estes.

O processo de forjamento foi realizado medindo-se a espessura, o diâmetro interno e o diâmetro externo do anel em diversos estágios da operação. Para os objetivos deste estudo considerou-se que uma deformação de 50% era satisfatória (diminuição da espessura do anel a metade da inicial). Esta deformação deve normalmente ser suficiente para assegurar o fechamento de bolhas e porosidades internas, bem como para promover uma estrutura mais fina em consequência da recristalização.

### 4. EXPERIÊNCIAS REALIZADAS

Com a finalidade de melhor esclarecer o trabalho realizado, parece interessante apresentar um relato mais detalhado das duas primeiras experiências realizadas. É de notar, porém, que após essas experiências que visaram a obtenção de dados sobre o comportamento dos anéis no forjamento, foram produzidos com sucesso mais de dez anéis forjados, para atender a solicitações da indústria local. Os resultados de mais dois forjamentos são dados em tabela no fim do trabalho.

#### 4.1. Primeira experiência

##### Fundição

O processo usado para a fundição do anel a ser forjado não se diferenciou muito do utilizado habitualmente.

As dimensões do modelo usado para a confecção do anel foram as

seguintes:

Diametro externo (D): 53 cm  
 Diametro interno (d): 37 cm  
 Espessura: 10 cm

O molde foi feito com a seguinte areia:

Areia do mar:	60% (módulo de finura: 90 a 100 AFS)
Areia usada:	40% (módulo de finura: 90 a 100 AFS)
Argila:	4% da areia base
Mogul:	1,5% da areia base
Óleo + breu	2% da areia base
Água:	5% da areia base

O molde foi estufado a cerca de 200°C durante duas horas, sendo depois colocado inclinado de mais ou menos 10°, com relação horizontal, para o vazamento (Figs. 1 e 2).

O sistema de alimentação está indicado nas Figuras 1 e 2. Foi feito um canal de descida oposto ao massalote; partindo desde canal há 2 canais de distribuição cada um com 3 canais de ataque (de entrada). O massalote único ficou situado na parte mais alta do molde. Assim, conseguiu-se que o metal, ao entrar, percorresse todo o molde, nos dois sentidos e tangencialmente as paredes do mesmo, indo se encontrar praticamente no massalote. A inclinação dada serviu para ajudar a alimentação. As dimensões dos canais foram as seguintes:

Canal de descida:	diametro de 4,5 cm
Canal de distribuição e canais de ataque:	largura de 6 cm e espessura de 2 cm
Massalote:	largura de 10 cm, espessura de 30 cm, e comprimento de 15 cm
Junção do massalote a peça:	largura de 6 cm; espessura de 11,5 cm, e comprimento de 6 cm.

O molde foi pintado com mistura de grafita, dextrina, bentonita e água.

Fusão da liga: a liga fundida deveria ter a seguinte composição: 2,5% Co, 0,5% Si e o restante cobre. Como as perdas por oxidação do cobalto e do silício são relativamente elevadas, adicionou-se um excesso de 0,5% Co e de 0,3% Si para compensá-las.

A preparação da liga procede-se habitualmente como segue: prepara-se primeiramente uma liga auxiliar ("liga-mae") de cobre com todo o cobalto e silfício; funde-se o cobre, protegido da atmosfera por escória apropriada, para evitar excessiva oxidação do banho, embora este deva estar levemente oxidado a fim de se eliminar ou evitar a entrada de hidrogenio. Quando o cobre estiver fundido, adiciona-se a liga auxiliar, retira-se a escória e procede-se ao vazamento. A desoxidação da liga é feita pelo próprio silfício de carga, o qual é colocado em excesso.

Na primeira experiencia realizada aproveitou-se, porém, sucata de aneis defeituosos e de canais de corridas anteriores, usando-se somente 50% de carga nova. Cobriu-se o banho com uma mistura de borax e vidro em cacos, para protecao. Depois de fundida a carga e colocada a "liga-mae", retirou-se a escória fluida e procedeu-se ao vazamento a 1200° C aproximadamente. Do forno (que no caso era um forno tipo Fisher, a óleo com cadinho carborundum), vazou-se numa panela préaquecida dotada de "bico de chaleira" para depois vazarse no molde. A liga auxiliar foi preparada num forno de inducao, tipo Ajax, em cadinho de grafita.

Retiraram-se cavacos dos canais para análise química, a qual acusou 2,81% Co e 0,68%Si. Assim, verificou-se que basta um excesso de 0,2 a 0,3% Co e de 0,2% Si para que a liga final fique dentro da especificação.

A dureza da peça simplesmente fundida foi de 47 Rockwell B.

As dimensoes da peça fundida foram as seguintes:

Diametro externo (D): 53 cm  
 Diametro interno (d): 36 cm  
 Espessura: 9,9 cm

Defeitos e dificuldades observados:

- a) Aparecimento de "chupagem" na parte onde o massalote esteve unido a peça. Esta dificuldade foi vencida pelo uso de um massalote dotado de uma junção mais grossa e melhor dimensionado, conforme artigos especializados em cálculo de canais em ligas de cobre<sup>(3)(4)</sup>.
- b) Aparecimento de uma superfície rugosa e acidentada na parte onde o metal entrou na peça pelos canais de ataque. Conseguiu-se melhorar muito o aspecto da superfície, colocando-se os canais de ataque tangenciais a peça.
- c) A entrada de escória no molde foi evitada com o uso do "bico de

leira" na panela de vazamento.

### Forjamento

Depois de rebarbada a peça, ela foi encaminhada para o forjamento. Nesta primeira peça, procurou-se apenas verificar a sua forjabilidade e o modo como se deformava durante a operação.

Aqueceu-se o anel até cerca de 900° C e forjou-se até uma espessura de 6 cm, medindo-se, então, os diâmetros interno e externo, de modo a se ter uma primeira idéia das deformações. A seguir, voltou o anel para o forno de aquecimento (forno aquecido a óleo com maçarico), a fim de reaquece-lo a 900° C. Forjou-se depois até uma espessura total de 5 cm e procedeu-se a medida dos diâmetros. Teve-se uma redução de 50% de forjamento. A tabela seguinte fornece os resultados.

Espessura (cm)	D (cm)	d (cm)
9,9 (inicial)	53	36
6,0	64	43
5,0	66	44,5

A peça forjou bem, não apresentando empenamento, deixando apenas de permanecer perfeitamente redonda (as medidas dos diâmetros externo e interno corresponderam a médias de várias medidas, pois em certas regiões da peça houve maior ou menor alargamento). Isso deveu-se a forjamento não uniforme, forjando-se mais fortemente algumas partes e menos outras. Na região onde estava situado o massalote notou-se o início de uma trinca superficial, demonstrando ser essa uma região crítica.

Constatou-se, portanto, que a liga usada é perfeitamente forjável na temperatura inicial de 900° C e que, para se obter alargamento uniforme, não se deve usar o martelo de forja muito fortemente ou com pancadas desiguais.

A dureza da peça forjada subiu para 52 Rockwell B.

### Tratamento térmico

Sendo esta questão muito crítica para o caso de ligas de cobre de alta condutividade, pois é o que determina praticamente as propriedades mais importantes para o uso da liga, será feito um estudo que tratará exclusivamente deste problema, e que será objeto de trabalho posterior. No entanto, convém citar os resultados obtidos.

Depois de forjada, a peça foi submetida a um tratamento de solubilização e precipitação. Estes tratamentos foram feitos da seguinte maneira:

- Solubilização: aqueceu-se a peça a 900° C durante 2 horas, resfriando-se em água.
- Precipitação: aqueceu-se a peça a 450° C durante 3,5 horas, resfriando-se ao ar.

A dureza obtida após a solubilização foi de 54 Rockwell B. A dureza obtida após a precipitação foi de 76 Rockwell B.

#### 4.2. Segunda experiência

##### Fundição

A técnica de fundição usada foi a mesma já descrita, exceto no que diz respeito a matéria prima: devido ao excesso de cobalto e de silício verificado na análise da corrida anterior, adicionou-se menor quantidade desses elementos. Assim, os teores de cobalto e de silício introduzidos na carga por intermédio da liga auxiliar foram de 2,8% Co e 0,7% Si, o que correspondeu a um excesso de apenas 0,3% Co e 0,2% Si.

A análise química desta segunda corrida revelou: 2,76% Co e 0,52% Si, o restante sendo cobre, composição essa geralmente recomendada para esta liga.

Procedeu-se normalmente ao vazamento, inicialmente pelo canal de descida até encher a peça, terminando por vaziar pelo massalote para melhor assegurar a limentação.

As medidas da peça fundida foram as seguintes:



\*\*\*\*\_o

Diámetro externo (D): 53 cm  
Diámetro interno (d): 35,5 cm  
Espessura: 9,8 cm

As dimensões dos canais foram as seguintes:

Canal de descida:	diámetro de 5 cm
Canal de distribuição:	largura de 6 cm e espessura de 2 cm
Tres canais de ataque:	largura de 6 cm cada um e espessura de 2 cm
Massalote:	largura de 10 cm, espessura de 28 cm e comprimento de 20 cm
Junção do massalote a peça:	largura de 8 cm, espessura de 13 cm e comprimento de 8 cm

### Forjamento

O forjamento da peça foi realizado conforme foi programado, isto é, partindo de uma espessura de 10 cm (praticamente), forjou-se em etapas, reduzindo-se a espessura de centímetro em centímetro até atingir-se uma espessura final de 5 cm aproximadamente. Cada vez que era reduzida a espessura de 1 cm, mediu-se o diámetro externo e o diámetro interno para se observar a deformação. Após cada medida, a peça retornava ao forno de aquecimento para atingir-se de novo a temperatura de forjamento (900°C). Obteve-se, assim, a seguinte tabela:

Espessura (cm)	D (cm)	d (cm)
9,8	53	35,5
9,0	56	38
8,0	57	40
6,8	61,5	41,5
5,9	65,5	43
5,0	67	44

### Tratamento térmico

Foi o mesmo que na experiencia anterior.

## 5. ANÁLISE DOS RESULTADOS OBTIDOS

Com as medidas feitas, pode-se traçar alguns gráficos úteis para prever a deformação dos anéis durante o forjamento (Figs. 3 e 4).

Para generalizar os resultados obtidos, é interessante exprimi-los também, em porcentagens de aumento de D e d, em função da espessura h (Figs. 5 e 6). Estes últimos gráficos dão as medidas em que deverão ser forjados os anéis de qualquer tamanho, em liga cobre-cobalto-silício, para se obter, no final, as dimensões desejadas para os mesmos.

Cálculo das porcentagens de aumento nos diâmetros D e d: Chamando de  $\Delta D$  e de  $\Delta d$  as porcentagens de aumento nos diâmetros externo e interno, respectivamente, e de  $\Delta h$  as porcentagens de redução da espessura, tem-se:

$$\Delta D \text{ ou } \Delta d = \frac{\text{dimensão após algum forjamento} - \text{dimensão inicial}}{\text{dimensão inicial}} \times 100$$

Obteve-se, assim, a tabela das porcentagens de redução na espessura e do aumento nos diâmetros. Dos dados desta tabela, conclui-se que durante a redução da espessura dos anéis a metade, por forjamento, nos diâmetros externo e interno aumentam de cerca de 25%. Naturalmente que, para cada caso, é necessário fazer-se uma experiência prévia para se determinar exatamente a variação das dimensões.

## 6. ESTRUTURA DAS PEÇAS

Foram realizados alguns exames metalográficos com o objetivo de melhor avaliar o efeito do forjamento e do tratamento térmico.

As macro e micrografias das Figuras 7, 8, 9 e 10 ilustram os tipos de estrutura observados. É facilmente observável a melhoria da estrutura pelo forja-

---

Tabela das porcentagens de reducao na espessura  
e do aumento nos diametros

---

$\Delta h$ (%)	$\Delta D$ (%)	$\Delta d$ (%)
1a. Experiencia		
40	20,7	19,5
50	24,5	23,6
2a. Experiencia		
10	5,7	7
20	7,5	13
30	16	17
40	23,5	21
50	26,5	25
3a. Experiencia		
10	7,5	5
20	12	9
30	17	12,5
40	24	21
50	26	24
4a. Experiencia		
10	7,5	9
20	12,5	13,5
30	16,5	18
40	22	23
50	25	25

---

mento seguido do tratamento térmico.

7. CONCLUSOES

Da experiencia adquirida na Secção de Ligas Nao-Ferrosas da Divisao de Metalurgia do I. P. T., pode-se concluir o seguinte:

- a. A produçao de eletrodos girantes para solda de tubos é problema que vem preocupando a indústria nacional, obrigada a importa-los ou a lançar mao de uma produçao local ainda insuficiente em quantidade e qualidade.
- b. A produçao de aneis de boa qualidade para eletrodos girantes, apenas por fundiçao, é difficil. O forjamento, garantindo a compacidade das peças bem como promovendo um refino de grao (por recristalizaçao), permite a obtençao de peças de boa qualidade e adequadas para a aplicaçao em vista.
- c. O forjamento provoca uma alteraçao das dimensoes, que precisa ser estudada previamente. No caso dos aneis estudados no I. P. T. observou-se que, para uma reduçao da espessura de 50%, os diâmetros interno e externo aumentavam de cerca de 25%.
- d. Para melhor estudar e resolver os problemas de produçao de eletrodos girantes, nao só de Cu-Co-Si como de outras ligas de cobre de alta condutividade, de modo a divulgar a técnica e melhor atender as necessidades da nossa indústria, é necessário prosseguir nos trabalhos iniciados, o que será feito pelo I. P. T.

BIBLIOGRAFIA

1. Bradaschia, Clovis - "A fundição de eletrodos girantes para a solda elétrica contínua de tubos". ABM-Boletim, vol.10, pag. 271, 1954.
2. Heuvert, René - "Eletrodos em discos na fabricação de tubos soldados". ABM-Boletim, vol. 11, pag.411, 1955.
3. Ruddle, R.W. - "Gating copper alloy castings". Foundry, dezembro de 1959, vol. 87, nº 12, pag. 72.
4. Ruddle, R.W. - "Risering copper alloy castings". Foundry, janeiro de 1960, vol.87, nº1, pag. 78.

AGRADECIMENTOS

Os autores agradecem a preciosa colaboração da Secção de Metalografia e da Secção de Aços (onde foram forjados os anéis).

PROPIEDADES DE UNA ALEACION DE COBRE DE ALTA RESISTENCIA  
AL ABLANDAMIENTO Y ALTA CONDUCTIVIDAD

por D. Obrutsky, M. Sarrate y O. Wortmann

Introducción

Trabajos previos de Saarivirta (1) y Saarivirta y Taulenblat (2) muestran que las aleaciones binarias Cu-Zr ofrecen interesantes perspectivas en el campo de las aleaciones de alta conductividad y alta resistencia mecánica a moderadas temperaturas.

En efecto, estas aleaciones aparentan tener ventajas sobre las aleaciones actualmente en uso, principalmente Cu-Cr y Cu-Ag. Su elevada conductividad en el estado de solubilizadas y envejecidas, así como sus propiedades de resistencia al creep y resistencia a la rotura a temperaturas del orden de 400°C, las convierten en materiales interesantes para ser utilizados en la industria eléctrica de conductores, conmutadores, transformadores, contactos, etc.

Una aplicación importante es la de electrodos para máquina de soldar por resistencia. Cu-Zr por su resistencia al creep ofrece la posibilidad de obtener electrodos de gran durabilidad.

El SATI decidió encarar el estudio de la cinética de precipitación de estas aleaciones dado que la bibliografía no ofrece mucha información que es necesaria para la aplicación industrial de las mismas.

PROCEDIMIENTO EXPERIMENTAL

Se fundieron aleaciones de Cu-Zr de las composiciones que se muestran en la Tabla I. Se partió de Cu cátodo y Zr (pureza 98%). Las aleaciones se fundieron en horno de inducción, bajo una atmósfera de 400 mm Hg. de A.

Los lingotes obtenidos tienen las siguientes dimensiones:

$\phi = 40 \text{ mm}$

$L = 200 \text{ mm}$

Estos lingotes se extrudaron a alambión de 20 mm  $\phi$  con una relación de extrusión de 4 : 1 a una temperatura de 550°C.

Los distintos ensayos físicos se realizaron sobre alambre trefilado.

Dureza fué medida sobre un alambre de	$\phi = 5$ mm	Long. aprox.	5 mm
Corte, en microprobetas de	$\phi = 1,5$ mm	Long. aprox.	25 mm
Resistividad, en alambre de	$\phi = 0,5$ mm	Long. aprox.	400 mm
Fuerza electromotriz termoeléctrica en alambre de	$\phi = 0,5$ mm	Long. aprox.	400 mm

El trefilado del alambión de 20 mm se realizó en pasadas de 10%, con recocidos intermedios bajo atmósfera de A recubriendo las barras, en todos los casos, con una pintura protectora.

TABLA I

Probeta	Contenido de Zr en %
1	0.26
3	0.20
5	0.16
6	0.13
7	0.11
8	0.10
9	0.08
10	0.05
17	0.03

El límite de solubilidad de Zr en Cu es motivo de discusión. Saarivirta (1), en base a determinaciones metalográficas, ha establecido que es de 0.15% en peso a 980°C. Para Showak (3) por otra parte, es de 0.24 a esa temperatura, mientras que Donachie (4), utilizando la microsonda de Castaing, da el valor 0.17%, que se acerca al de Saarivirta.

En este trabajo hemos adoptado como límite de solubilidad de Zr en Cu el valor de 0.15% en peso a 980°C.

## ESTUDIO DE PRECIPITACION

Se han utilizado distintas propiedades (5) a fin de seguir la precipitación de Zr.

Dureza VPH  
 Metalografía  
 Conductividad  
 Fuerza electromotriz termoeléctrica  
 Rayos X  
 Dilatometría  
 Ensayos de corte

Estos ensayos se realizaron sobre probetas que han tenido 0% y 75% de deformación previa en frío. La temperatura de solubilización es en todos los casos de 950°C.

## Dureza

En las figuras 2, 3 y 4 se observa la variación de dureza en función del tiempo para probetas de diferentes tenores de Zirconio envejecidas a 500°C, 400°C y 300°C con 75% de deformación inicial.

En las curvas de 400°C y 500°C se observa en ambos casos la presencia de un pico de dureza que está entre los 2½ y 5 minutos. Lo anterior vale para composiciones comprendidas entre 0.08 y 0.26%.

A 300°C y 200°C la cinética es mucho más lenta, estableciéndose los picos de dureza en 2 horas a 300°C y entre 72 y 96 horas para 200°C.

Se observa que adiciones de 0.08% de Zr elevan sensiblemente la temperatura de recristalización. A 300°C la probeta con 0.08% Zr mantiene su dureza luego de 250 horas.

Para las probetas con tenores de 0.13% de Zr o superiores, los  $\Delta H$  máximos se obtienen para un tratamiento de envejecimiento de 5 min. a 500°C.

En la figura 5 se han resumido los datos anteriores para la probeta 5 (0.16% Zr): construyéndose la familia de isócronas.

Del análisis de éstas se verifica que a diferencia de lo que ocurre en Al-Ag, en la cual aparecen dos picos en la curva, en este caso un solo mecanismo aparenta ser responsable del endurecimiento.

## Probetas solubilizadas con 0% de deformación inicial

Para temperaturas de 400°C y 500°C se ha observado que los máximos valores de dureza se obtienen para 80 horas y 15 min. respectivamente. En las metalografías de las figuras 6 y 7 tomadas con tratamientos térmicos de 60 min. a 500°C se observa la presencia de una estructura de Widmanstätten característica.



La fase precipitada es de composición  $\text{Cu}_3\text{Zr}$  (1) (2) (6). Dada la similitud en dimensiones cristalográficas entre Ti y Zr es razonable suponer que análogamente a lo que ocurre en aleaciones Cu Ti (7) la que precipita es una fase ordenada  $\text{Cu}_3\text{Zr}$ , isomorfa con el  $\text{Cu}_3\text{Ti}$  (8) (9).

#### Dilatometría y Rayos X

En este trabajo se han hecho determinaciones dilatométricas utilizando un dilatómetro Chevenard, realizando envejecimientos isotérmicos en el rango 200°C a 500°C. Con la precisión con que se contaba, en ningún caso se pudo observar variación de longitud. El coeficiente de amplificación del dilatómetro es = 1100.

Las mediciones de parámetro de red se realizaron con precisión de  $1 \times 10^{-3}$  Å utilizando el método de polvos con Cámara Debye Scherrer.

El parámetro se midió utilizando los dobletes  $\text{K}\alpha_1$   $\text{K}\alpha_2$  para los planos 331 y 420.

Se estudiaron probetas de composiciones crecientes de Zr 0.08, 0.13, 0.20 y 0.26 solubilizadas a 950°C y templadas.

No se observa que para composiciones crecientes el parámetro de red varíe con la composición.

Para probetas envejecidas no se observa la presencia de una segunda fase. Esto es explicable dada la pequeña cantidad de Zr presente.

#### Ensayos mecánicos

Con el objeto de comparar cualitativamente los distintos tratamientos térmicos para diferentes composiciones se realizaron ensayos de corte usando la micromáquina Chevenard. En dicho equipo la curva  $\tau$  en función de la deformación se inscribe por medio de registro fotográfico.

En la figura 8 se han representado los valores de  $\tau_{0.8}$  que provocan una deformación permanente igual a 0.8% del diámetro inicial. Esto se ha tomado como índice cualitativo de la resistencia a la deformación plástica del material.

Las propiedades mecánicas (flow stress) aumentan con el contenido de Zr hasta alcanzar un máximo para valores de Zr de aproximadamente 0.17% en peso.

Del análisis de la figura se observa que existe una caída en el valor de  $\tau_{0.8}$  al progresar el proceso de envejecimiento, caída que aumenta cuanto menor es el contenido de Zr.

Este efecto se manifiesta aún más claramente en la figura 9 en la que se ha representado el valor de  $\tau_{0.8}$  en función del tiempo de envejecimiento a distintas temperaturas para un contenido de 0.16% de Zr, con deformación previa del 75%.

Esta disminución inicial no concuerda con las curvas de dureza a esta misma temperatura (figura 2).

Dicha anomalía se atribuye a que el ensayo de corte se realizó en un plano normal al eje de trefilado.

La textura que es dable esperar en alambre trefilados de cobre consiste en forma preponderante de cristales con la dirección  $[100]$  y  $[111]$  paralela a la dirección de trefilado. La precipitación de  $\text{Cu}_3\text{Zr}$ , que se realiza en planos preferenciales, produce fuerte direccionalidad en las propiedades mecánicas.

### Conductividad

Medir la conductividad es una técnica importante para seguir cinéticas de precipitación.

En efecto (10) variaciones grandes de conductividad deben atribuirse preponderantemente a "clustering" o precipitación de átomos de soluto.

La medición de conductividad se realizó utilizando un potenciómetro K3 Leeds y Northrup.

Se mide la tensión sobre la probeta incógnita y sobre una resistencia patrón invirtiendo la corriente para evitar influencias de las resistencias de contacto. Luego de realizadas dos medidas con la corriente en distintos sentidos se promedian los resultados.

En la figura 10 se ha representado las curvas isócronas para 1 h. y 24 hs. de envejecimiento de Cu - 0.16% Zr con 0% y 75% de deformación. Se observa un aumento continuo de la conductividad con la temperatura del tratamiento térmico.

Los valores absolutos muestran que las probetas deformadas 75% alcanzan para iguales tiempos mayores valores de conductividad.

Esto es razonable teniendo en cuenta que la presencia de defectos producidos por el trabajo aumenta la cinética de precipitación.

Es decir, son necesarios menores tiempos para alcanzar iguales niveles de precipitación en probetas que han sufrido deformación en frío.

## Fuerza electromotriz termoelectrica

Se midió la fuerza electro motriz producida al calentar a 100°C una termocupla construída de la siguiente manera:

- a) Un alambre de Cu recocido.
- b) Un alambre de Cu-Zr solubilizado templado y envejecido por periodos diferentes.

En todos los casos se refirió la tensión al valor que se obtendría tomando como uno de los elementos del par un alambre de Cu-Zr solubilizado y templado.

En la figura 11 se observa la variación de la fuerza electromotriz termoelectrica para probetas con 0.16% de Zr.

Tal como se puede apreciar, la f. e. m. cambia en forma parecida a la conductividad en función del tiempo de envejecimiento (Fig. 11).

## Energía de activación del proceso de precipitación

Si se supone que la precipitación es un proceso controlado por difusión, la expresión de velocidad de transformación responde a una expresión de la forma

$$\frac{1}{t} = e^{-\frac{Q}{RT}}$$

siendo t el tiempo. Suponiendo que Q sea independiente de la temperatura, se obtiene una expresión que representada en escala semilogarítmica en función de  $\frac{1}{T}$  da una recta cuya pendiente es  $\frac{Q}{R}$ ; de aquí se puede despejar Q.

En nuestro caso hemos representado el lg. del tiempo necesario para alcanzar 1/2 de la máxima propiedad.

Se ha realizado esto para dureza, conductividad, y fem. Los valores obtenidos son:

Q dureza	= 23,000 cal/mol
Q fem	= 25,600 cal/mol
Q conductividad	= 22,000 cal/mol

## CONCLUSIONES

Se ha seguido la precipitación en aleaciones Cu-Zr utilizando dureza, conductividad, fuerza electromotriz termoeléctrica, dilatométrica, rayos X y etcétera.

Se verificó que adiciones de 0,08% Zr elevan notablemente la temperatura de recristalización, existiendo probetas que permanecieron 250 hs. a 300°C sin disminuir su dureza.

El máximo aumento de dureza se observa para envejecimientos de 5 min. a 300°C. Apparently un solo mecanismo es responsable por el envejecimiento, no presentando las curvas isotérmicas de dureza más que un solo máximo.

Las probetas precipitadas presentan una estructura de Widmanstätten característica, que por analogía y dada su similitud con Cu-Ti se supone que sea una fase  $\text{Cu}_3\text{Zr}$  ordenada e isomorfa del  $\text{Cu}_3\text{Ti}$ .

De las mediciones de parámetro de red se observó que la variación de la misma con la composición es muy pequeña ( $<$  que  $1 \times 10^{-3}$  Å).

Las propiedades mecánicas son dependientes de la orientación y esta dependencia es mayor cuanto mayor es el contenido de Zr.

La energía de activación de la precipitación se ha establecido en Q 23.000 cal/mol.

Para probetas solubilizadas, trabajadas 75% y envejecidas, las propiedades mecánicas son comparables y la conductividad es superior a las de Cu-Cr.

Por estas razones las aleaciones Cu-Zr presentan perspectivas interesantes dentro del campo de la industria eléctrica y de máquinas de soldar por resistencia.

## REFERENCIAS

1. SAARIVIRTA, Matti J. - "High Conductivity Copper Rich Cu-Zr Alloys" Transactions AIME, Vol. 218 June 1960 - 431-437.
2. SAARIVIRTA, Matti J.; TAULENBLANT, Pierre P. - "Some High Temperature Properties of Cu-Zr and Cu-Cr High Conductivity Alloys" Transactions AIME, Vol. 218 June 1960 - 935-939.
3. SHOWAK, Walter - "The Solid Solubility de Zr and Cu" Transactions AIME, Vol. 224 Dec. 1962, 1297.
4. DONACHIE, Matthew J. - "An Investigation of the Copper Rich Portion of the Copper Zirconium Phase Diagram by Electron Probe Microanalysis". The Journal of the Institute of Metals, February 1964, 180.
5. KÖSTER, Werner - "Eigenschaftsänderungen während der Aushärtung einer Kupfer - Chrom Legierung Zeitschrift für Metallkunde" Vol. 45 - 1954 pag. 350.
6. LINDEN, C.E.; McPHERSON, J.; HANSEN, M. - "System Zirconium Copper". Transactions AIME, Vol. 197, February 1953, 273-278.
7. BUCKIE, Charlotte; MANENC, Jack - "Etude de la precipitation dans les alliages binaires Cu-Ti riches in Cuivre". Memoires Scientifiques Revue Metallurgie. LVII No. 61960.
8. KARLSSON, Wils - "An X Ray Study of the Phases in the Cu-Ti System". Journal of the Institute of Metals 1951, Vol. 79, pag. 391.
9. DOI, Toshio - "On the Structure Changes Produced by Aging of Cu Ti Alloy". Acta Met., Vol. 7, April 1959.
10. KELLY, A.; NICHOLSON, R. B. - "Precipitation Hardening", Progress in Materials Science, Vol. 10, Pergamon Press 1963.

Tabla I.

Prueba N°	% Zr
1	0,26
2	0,20
3	0,16
4	0,14
5	0,12
6	0,10
7	0,08
8	0,05
9	0,03

Fig. 1 - Contenido de Zirconio de las aleaciones preparadas

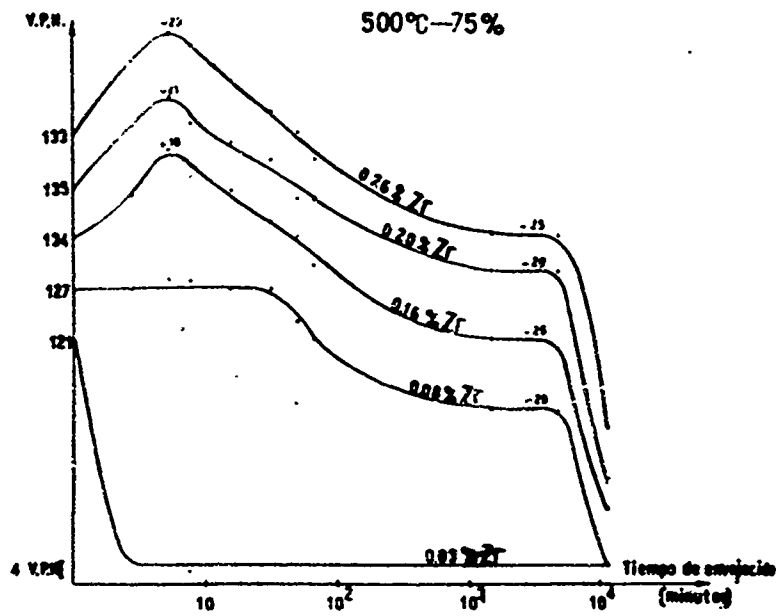

Fig. 2 - Variación de dureza Vickers en función del tiempo de envejecido.

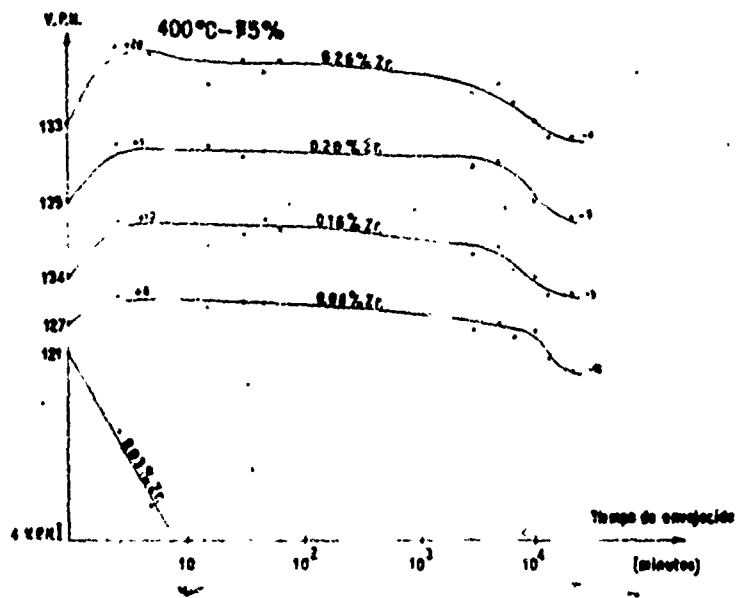

Fig. 3 Variación de dureza Vickers en función del tiempo de envejecido

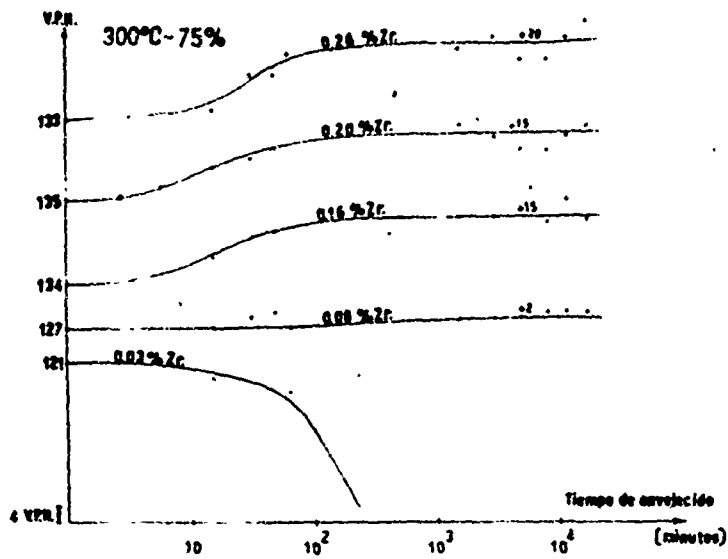

Fig. 4 - Variación de dureza Vickers en función del tiempo de envejecido.

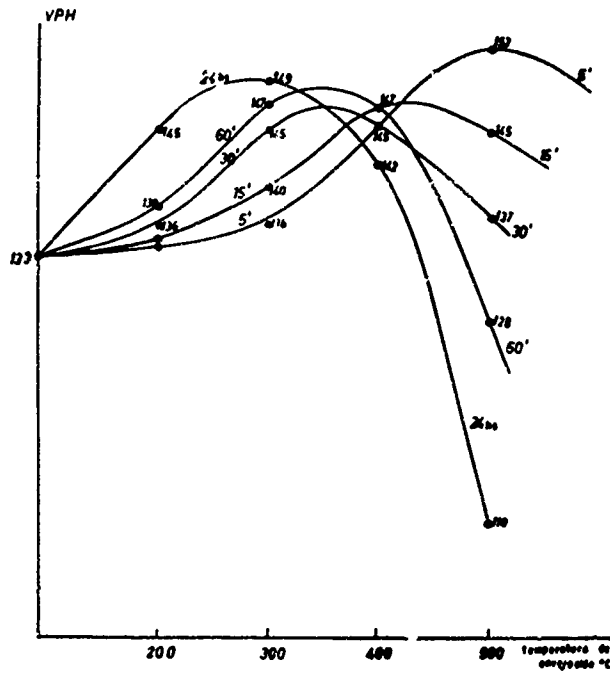

Fig. 5 - Isocrona de dureza para 0.16% de Zr con 75% deformación



Fig. 6 - Pulido por tampón  
 Reactivo  
 amoníaco y agua oxigenada  
 2:1. 400x





Fig. 7 - Pulido por tampón  
 Reactivo  
 amoníaco y agua  
 oxigenada  
 2:1 850x

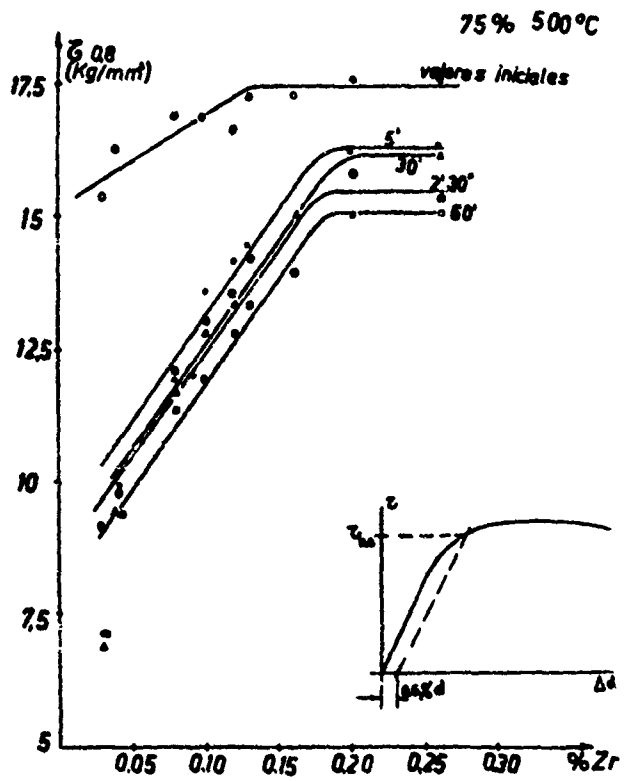

Fig. 8 - Propiedades mecánicas en función  
 de la composición para distintos  
 tiempos de envejecido

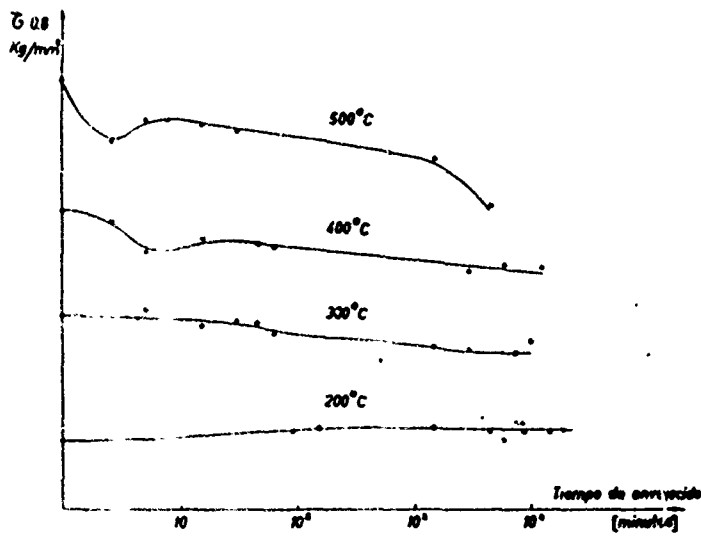

Fig. 9 -  $\sigma_{0.8}$  vs. tiempo de envejecido a distintas temperaturas para un contenido de 0.16% Zr con 75% de deformación.

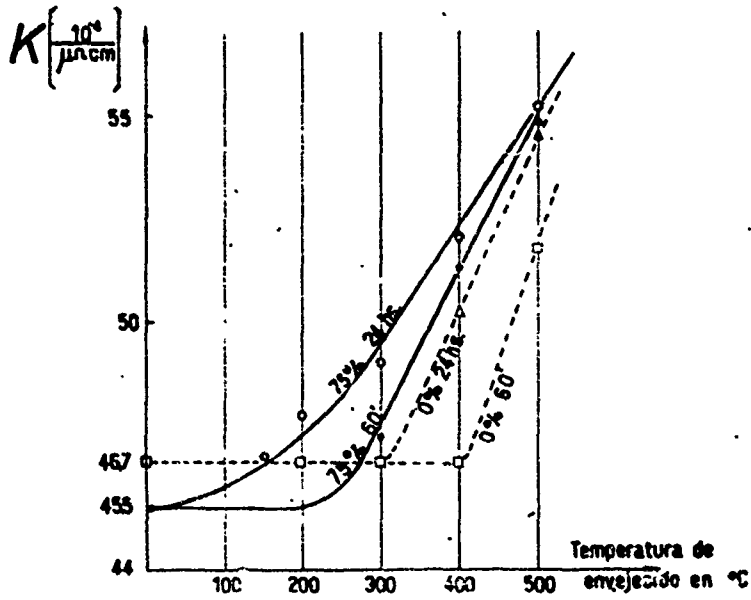

Fig. 10 - Isocronas de conductividad para 0.16% Zr.

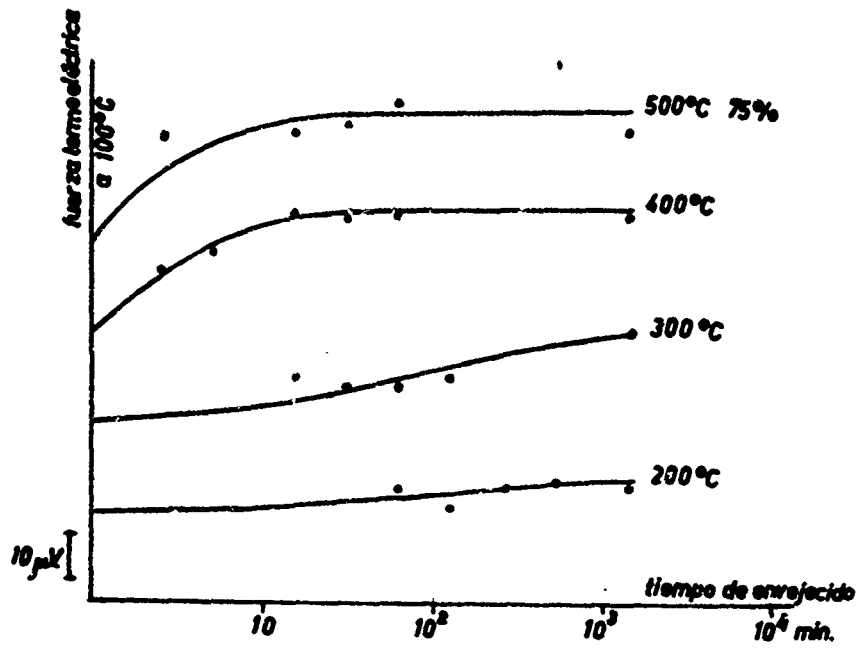

Fig. 11 - Variación de la fuerza electromotriz termoeléctrica para probetas con 0.16% de Zr.

## NONFERROUS METAL SHEET MANUFACTURING

---

By F. R. Morral

Semicontinuous casting, casting of thin slabs, and powder metallurgy are techniques used for producing sheet. Metallurgical characteristics and mechanical properties are discussed. Use of these techniques and related processes to manufacture sheet from common metals and alloys and from unusual metallic materials will be considered.

In companion papers, semicontinuous casting and casting of thin slabs of steel are discussed, as well as the production of steel sheet by powder metallurgy. Non ferrous metal sheet manufacturing follows these same principles, although the details may be simpler. In some instances, semicontinuous and continuous casting of slabs (the latter is also called "ingotless rolling") have proven advantageous over the method of casting ingots, working by various methods to plate or slab, then rolling to final size. The newer techniques are based on powder-metallurgy processes; a few illustrations will be given.

It can be said that the art of continuously casting both ferrous and non-ferrous metals has been developed to the point where any metal producer can undertake it. Only a little imagination may be required to adapt the process to more complex shapes. There are now about 50 variations of the process; however, no attempt will be made to discuss these since they have been presented in many articles and books<sup>(1)</sup>. Design of the unit and in-house construction should not present difficult problems, since compact melting and working units are available.

There are few nonferrous metals and alloys that have not been continuously cast on a production basis. So far, continuous casting of nonferrous metals has resulted in avoidance of turbulence and oxidation, better distribution of constituents, fine grain, and less porosity. Considerable savings have been effected by avoiding excessive scrap due to shrinkage voids and other defects. In general, the physical properties of finished continuously cast nonferrous metals have been better and more uniform than those of metals conventionally produced.

There are essentially these techniques:

1. Withdrawal of the billet directly from the liquid metal from furnace or ladle
2. Continuously rotating mold (Hazelett, Properzi)
3. Casting into water-cooled mold -usually semicontinuous casting. Although the fully continuous process gives nearly 100 percent yield and steady, continued production, it has an initially high cost and requires considerable head room, since the molten metal must be raised to a high level. While the yield with semicontinuous casting is in the range 96 to 99 percent, the cost of the plant is less and the molten metal is poured from ground level. Changes in size and shape of casting are also easy in the semicontinuous process, since a new mold can be put onto the second unit while the first is being poured. In small-scale production, pouring directly from the melting furnace offers many attractions.
4. Roll casting (Bessemer, Hunter-Douglas).

Problems still requiring attention are:

1. Solidification at mold
2. Strength of metal near its melting temperature
3. Heat transfer from ingot to mold, which controls the rate of ingot withdrawal
4. Fluidity of the metal
5. Efficient design of the mold
6. Efficient conditions and design of secondary cooling zone

7. Mechanism of formation of internal stresses in the ingot and means of reducing this detrimental effect

The advantages of continuous casting are:

1. Average yield is high
2. Lighter rolling equipment can be used since smaller sections are cast
3. Material quality is uniform and good
4. The mill is capable of meeting, or being developed to meet, most requirements
5. Little reheating is needed for immediate hot rolling.

#### Commercial Processes for Continuous Casting of Aluminum, Magnesium, and Their Alloys

In the United States, aluminum, magnesium, copper, and their alloys, and lead, zinc, tin, and nickel have been continuously cast for some years.

Several techniques are used to produce slabs 6 x 22 inches to 12 x 48 inches, with lengths up to 140 inches. That most used in America for aluminum is the ALCOA process, and in Germany, the equivalent VLW. These processes were developed between 1930 and 1940, and have also been used on brass with satisfactory results -sound slabs and surface quality. In both processes, the molten metal is controlled in a holding furnace before feeding into a stationary mold, or the metal is fed using electromagnetic pumping equipment. The plants are simple and economical and, although casting speeds seem slow in comparison with more elaborate plants, the advantages outweigh this one disadvantage. In one plant, there is complete integration -bauxite comes in one end, and aluminum sheet goes out the other.

The magnesium-type continuous-casting process is named for the company using it -Dow. Metal at about 1300 F (705 C) is pumped into the mold from 4,000-pound cast-steel pots. Virgin magnesium and scrap are charged into these pots and the mixture is heated to about 1400 F (760 C) for alloying and refining before casting. The pump is air-motor cooled. The mold, as short as possible, is made

of high-purity copper, although aluminum or magnesium could be used. It is encircled at the top and base with water-cooling rings. The top ring supplies a uniform film of water in downward streams over the mold exterior. The bottom ring directs water which assists that from the top ring and falls onto the cast product. Temperature and volume of the cooling water are carefully controlled. The whole unit should be on a rigidly supported base.

The Hunter-Douglas process for aluminum and its alloys is used particularly to produce aluminum sheet and strip and is also suited for foil. This is a horizontal continuous-casting process. Three Ajax low-frequency induction-melting furnaces, producing up to 6,000 pounds per hour, feed metal to two 20,000-pound gas-fired reverberatory furnaces. From open chutes in these furnaces, the metal is laundered to the casting machine. A constant and unbroken head of metal is maintained by means of an adjustable tap-hole valve. The mold in the casting machine is formed by two halves of a moving chain which consists of cast-iron blocks drilled for water cooling. As it leaves the endless chain, the metal has a temperature of 750-1000 F. After a 55-foot length of bar has been cast, a flying shear cuts it and it is rolled mechanically to a horizontal oven to be heated or cooled for hot rolling. Pinch rolls transfer the bar to a 6-stand tandem mill in which it is processed to 450-pound coils of 1/8-inch strip in about 60 seconds. The final operation is a cold reduction to gages between 0.0075 and 0.0092 inch with no intermediate anneals. Casting speeds run up to 15 feet per minute. The price of the caster, furnace, and auxiliary equipment is about \$500,000. Licensing and royalties are also involved<sup>(2)</sup>.

The Hazelett process has been suggested for aluminum, copper, brass, zinc, and steel. Molten metals poured between two belts are carried with them through the mill at speeds for aluminum of 27-35 feet per minute. Aluminum slabs 9 x 1/2 inch and strip up to 60 inches wide have been produced. It has been claimed that, with this process, stainless, silicon, and steel strip have been made with better properties than the same analysis rolled from conventional ingots. Now the cast metal strip is also continuously fed into a hot-rolling mill and then coiled (see Figure 1). The cost estimate for this equipment is nearly \$1,000,000, including the caster, furnace, auxiliary equipment, licensing, and royalties<sup>(2)</sup>.

Reynolds Metals Company recently announced a process for rolling sheet from pellets that could effect large savings in both plant investment and production costs. The new process operates continuously, produces a coil of sheet that may be of any length, and needs less equipment than a conventional rolling mill<sup>(3)</sup>. In contrast to heating and reheating large ingots, heat transfer to the small pellets is excellent, resulting in further savings in fuel costs. Pellets average 1/4 inch in length and 1/16 inch in diameter and must be free flowing. They are dropped through a vertical preheating furnace which brings their temperature to between

750 and 1000 F (400 and 540 C). Furnace time for each pellet is approximately 4 seconds, compared with several hours for an ingot. Hot pellets are fed between a pair of rolls where they are formed into a fully consolidated sheet. Thickness of sheet ranges from 0.1 inch down to foil gage. The company believes that the new process will have a significant impact on the aluminum-sheet industry.

A process suitable for aluminum strip and extrusion slugs is that developed by the Albert Mann Engineering Company, Ltd., of England. This consists of a rotary strip casting machine which produces up to 20-inch widths and permits easy changes in product size. The cost of the caster, furnace, and supporting equipment is quoted at about \$250,000. A company to produce 6,000,000 pounds of aluminum product per year should be able to recover its investment within a year in the United States. Licensing and royalty arrangements are not required(4).

A machine best suited for bus bars and extrusion billets has been recently described by Ugine. Figure 2 shows the general arrangement for the Ugine-Venthon horizontal-casting process. Slabs 4 to 8 inches thick and billets 4 inches in diameter and larger are cast.

### Powder-Metallurgy Techniques

H. Bessemer, in his autobiography, remarks that in 1843, while rolling fine brass turnings preparatory to making powder, the brass filaments tended to "issue from the rolls with a smooth continuous surface resembling an ordinary sheet of solid brass"(5). Therefore, he may be considered the grandfather of this technique of producing sheet and strip from powders. During the past 15 years, many powder-metallurgy processes have been patented(6).

The mechanism of compacting metal powder by rolling has been reviewed in detail by Evans(7) and others. Evans describes the effect on the finished material of such important factors as the rolling mill (roll diameter, size of roll gap, surface finish of roll, rate of powder feed to the roll, and roll speed), the powder (grain and particle size), and sintering (temperature, time, and protective atmosphere).

Direct powder rolling is expected to be cheaper and more continuous than the use of the pressed and sintered form, which is then rolled (possibly hot) to a certain thickness and then cold rolled to final size(8).

The cost of manufacturing components by powder-metallurgy techniques can



be greatly reduced by the use of automatic methods which make continuous compacting possible. In a companion paper, some requirements have been outlined. For the production of sheet, it may be interesting to note that the process originally suggested by Sir Henry Bessemer for liquid metals can be used on powdered metals. Here the rolls are generally heated instead of cooled. The process of sheet-making consists of sintering after rolling the powders, and then re-rolling to finished size. X

In the manufacture of very thin metal strip, the "direct rolling" of loose powders does, in some cases, have an economic advantage over the rolling of wrought metal. In direct rolling, powders are fed from a hopper directly into the throat of vertically or horizontally mounted rolls. The powders are carried by the surfaces of the rolls into the neck where they are compressed and finally ejected. It is well established that direct rolling of powder is most effective in producing very thin strip. A single pass through the rolls can provide 20- to 30-mil strip without difficulty.

Some aspects of direct rolling are not yet clearly understood. For example, much has yet to be learned about the effect on density and strip thickness of such factors as the diameter and pressure of the rolls, the shape and size of the powder, and the rate at which the powder is fed into the rolls. We have learned that the best product results when the diameters of the rolls are several hundred times the thickness of the strip and when powders of high green strength are used at moderate compression ratios (best to resist the stresses induced). By controlling these variables, densities up to 90 per cent of theoretical can be obtained for some metals in a single pass.

General factors affecting the sintering process are given in Table 1. Four types of factors must be closely considered -material (including source or method of making), particle size, compacting, and actual sintering. The sintered product may then be worked -hot or cold- to produce the final sheet or strip.

Continuous compacting of nickel, cobalt, copper, aluminum, and their alloys is a reality. This process merits much consideration if powder prices are low, if special properties are required, or only small runs are desired.

In 1958, Lund reported that the production of pure nickel strip by the continuous roll compacting of hydrogen-precipitated nickel powder, followed by suitable sintering and cold rolling, is practicable<sup>(9)</sup>. The mechanical properties of strip produced by this process are at least comparable to those of cast and wrought nickel in the same temper condition. Considerable amounts of this strip are now being coined into Canadian 5-cent pieces--truly "nickels"!

The process described below is a recent one, being used for nickel and

cobalt powder. The description is specifically of the production of cobalt strip on the rolling mill of the Sherritt-Gordon Mines Refinery in Fort Saskatchewan, Alberta, Canada.

Nickel and cobalt powders have a characteristically irregular shape. This appears beneficial in the production of a strong green strip on roll compacting. At Sherritt-Gordon, roll compacting is accomplished on a horizontally mounted unit so that the strip emerges vertically downward, is turned 90°, and wound into coils. The green strip is nominally 0.064 inch thick and 6-1/2 inches wide, with a theoretical density of 80-85 per cent that of the solid metal. The green strip is fed into a hot coiling furnace at 925 C. The sulfur content is lowered to 0.005 per cent and the carbon to 0.008 per cent by a moving hydrogen atmosphere, which prevents oxidation. When the strip is coiled in the furnace, the temperature is raised to 950 C. Hot rolling with a 25 per cent thickness reduction is followed by water-spray cooling and coiling under hydrogen atmosphere to prevent oxidation and discoloration. The density of the 0.048-inch thick cobalt strip is 8.72 g/cc (or 98.5 per cent of theoretical). The strip is annealed at 750 C after edge slitting and cold rolled 20 to 25 per cent in area. Annealing is done in bell furnaces at 930 C for 1 hour. The tensile properties are very sensitive to the procedure for obtaining tensile-test specimens and to the annealing temperatures<sup>(10)</sup>. In the case of cobalt, the close-packed hexagonal phase may be present, together with the face-centered cubic. It has been established that elongation values increase almost linearly, from 4 to 26 per cent, as the amount of cubic phase present increases from 7 to 50 per cent. Cold working affects the magnetic properties of cobalt, raising the remanence slightly and the coercivity considerably. Magnetostriction measurements agree with previously reported data.

Part of the reason for the improved properties may be the fine grain size, resulting from starting with fine powders. It is possible that, in some materials, the presence of oxides has a dispersion-hardening effect.

Sintered cobalt powders have been extruded in long bars with cross sections of varying complexity, and with densities close to 100 per cent.

The availability of cobalt strip opens new applications for this material such as anodes for electroplating and electroforming, memory tapes (because of high Curie temperature and other magnetic properties), tubing for inhomogeneous welding rods, bearings, and catalytic devices.

In general, the production of satisfactory sheet and other parts depends on factors indicated in Table 1. Table 2 gives data on sintering temperature and time for eight industrial elements and alloys.

Powder metallurgy is used to produce special sheet material, such as

dispersion-hardened nickel, known as TD-Ni (thoria dispersed in nickel). Experimental work has been done in which 5- and 10-mil fibers of tungsten have been embedded in cobalt powder; interesting properties at 2000 F (1095 C) have been obtained. (Metal whiskers could also be used). For these purposes, submicron powders both for "dispersant" and "dispersoid" are needed. To obtain the properties desired for TD-Ni, the mixture of powder has to be extruded. In fact, copper tubing is now under development and is believed to be economically feasible. The tubing made of copper powder seems to have unique features: greater toughness, improved formability, and higher yield strength. Reasons for these improved properties are not yet known. One contributing factor may be the dispersion-hardening effect of copper oxide particles.

There are three basic methods of extrusion: (1) direct extrusion of powders, (2) extrusion of pressed billets (as used for TD-Ni), and (3) extrusion of "canned" powder. The superalloy René 41 normally takes only 10-15 per cent cold work without annealing, but when starting with canned elemental powders, it is possible to cold reduce to 70 per cent. René 41 weld rods are made in this way.

Some alloys in the United States are available as powder. Another technique that has some promise is that of using precoated powders. Each grain (metal or nonmetal) is coated with a metal. In fact, individual grains can receive several different coatings of various elements. An interesting material is strip of a given porosity, such as may be used for plain bearings, filters, or air-permeable parts for pneumatic conveyors.

New technical properties can be imparted by the incorporation of certain additions to the metal powders before the sheet is produced (. e. g. , the frictional properties of bronze parts are improved by additions of graphite).

Of course, to make sheet or strip of refractory metals -W, Mo, Cb, etc. - the powder-metallurgy technique appears to be the only feasible one.

There is not time here to compare mechanical properties of metal and alloy sheet and strip made by semi- or continuous casting, or powder metals made with the conventional methods of melting, casting, and fabricating. The purity of the materials involved, the amount of work given, and in some instances, the heat treatment, make comparisons of tensile strength meaningless. An example is given in Table 3 for nickel sheet produced by powder metallurgy. Table 4 compares the properties of 316 stainless steel and Inconel made by powder metallurgy versus conventional processes<sup>(11)</sup>. Table 5 gives properties for a nickel-base superalloy, Udimet 500. Note that the extrusion product by powder metallurgy has properties in excess of those of the wrought material.

Curtiss Wright reported that, in their processing of scrap to powder, the

the cost for the latter ranged from 17.8¢ / lb for a 10-ton/day plant to 8.3¢ / lb for a 100-ton/day plant<sup>(11)</sup>. Sheet processing costs were estimated at about 10¢ / lb for a 50-ton/day plant making various grades of stainless steel and 25¢ / lb for a 10-ton/day plant turning out specialty alloys. They concluded that cost analyses looked favorable.

Should Central and South American countries consider the metal-fabrication processes discussed in this and companion papers? The answer lies in the following questions:

1. Is there a market or will there be one for materials or products manufactured by them?
2. What are the sources and prices of raw materials?
3. Can the equipment be produced in your country or must it be purchased from hard-money countries and imported?
4. Do you engineers have ideas to simplify or adapt these processes to your own specific needs?

Although the first item mentioned is the most important, it is the last that holds the key to the success of any method adopted. The possible economic advantage of these new methods (semi- and continuous casting and powder metallurgy) is evident; however, this is true only if your creative ability can adapt them to your own specific requirements. Here again, today's creative planning can mean tomorrow's productive living!

TABLE 1. FACTORS AFFECTING SINTERING PROCESS

<b>A. Material factors:</b>	<b>B. Particle factors:</b>
Crystal structure	Method of fabrication
Diffusion coefficient	Particle shape
Melting point	Particle surface conditions
Density	Particle size
<b>C. Compacting factors:</b>	<b>D. Sintering factors:</b>
Compacting pressure	Sintering temperature
Compacting temperature	Time at temperature
Compacting speed	Sintering atmosphere
Compacting atmosphere	Rate of heating
Duration of compacting	Rate of cooling

TABLE 2. SINTERING TEMPERATURE AND TIME  
(IN HIGH HEAT CHAMBER)

Material	Temperature, C	Time, minutes
Bronze	760 - 870	10 - 20
Copper	845 - 900	12 - 45
Brass	845 - 900	10 - 45
Iron, iron-graphite, etc.	1010 - 1150	8 - 45
Nickel	1010 - 1150	30 - 45
Stainless steel	1095 - 1290	30 - 60
Alnico magnets	1200 - 1300	120 - 150
Tungsten carbide	1425 - 1480	20 - 30

TABLE 3. PROPERTIES OF NICKEL STRIP MADE BY DIFFERENT METHODS

Material	Impurities, %							UTS tons/ in. <sup>2</sup>	Elong % on 2-in Test Gage Value		
	C	S	Fe	Si	Mn	Al	Mg			Cu	
Directly Rolled Nickel											
Soft*	0.01	0.001	0.005	0.005	0.005	0.01	0.005	0.005	24.4	19.0	8.91
						ca.					
Hard (64% reduction)	0.01	0.001	0.005	0.005	0.005	0.01	0.005	0.005	36.5	1	3.10
						ca.					
Conventionally Made Nickel											
Soft*	0.04	0.002	0.1	0.05	0.03	--	0.1	0.1	24.1	20.0	9.35
Hard (38% reduction)	0.04	0.002	0.1	0.05	0.03	--	0.1	0.1	44.3	1	4.50

\*Materials annealed under conditions to give a grain size of about 0.02 mm. Directly rolled nickel annealed for a nominal period of 30 sec. at 700 C; conventionally made nickel annealed for a similar period at 925 C.

TABLE 4. HOW POWDER STRIPS COMPARE

	Rolled 316 Stainless Strip(a)		Rolled Inconel Strip(b)	
	Powdered	Commercial	Powdered	Commercial
<b>Room-Temperature Properties</b>				
Yield strength, psi	46,800	29,900	34,200	30,300
Ultimate tensile strength, psi	101,000	78,900	90,550	84,410
Elongation, per cent	38.3	59.9	25.2	30
Hardness when heat treated, R <sub>c</sub>	--	--	--	--
<b>High-Temperature Properties</b>				
Time to rupture (in air at 1500°F under 10,000 psi load), hours	--	--	9.8	6.2
<b>Corrosion Test</b>				
Boiling 65% HNO <sub>3</sub> for 96 hours	7.5 mils/yr	8.6 mils/yr	--	--
<b>Interstitials</b>				
Carbon	0.07 %	0.05 %	--	--
Oxygen	0.05 %	0.01 %	--	--
Nitrogen	220 ppm	535 ppm	--	--
Hydrogen	17.4 ppm	12.7 ppm	--	--

(a) Annealed at 2025 F for 30 minutes

(b) Annealed at 1800 F for 30 minutes

TABLE 5. PROPERTIES OF UDIMET 500 POWDER-METAL EXTRUSIONS  
(Heat Treated)(a)

Specimen	Tensile Strength, 1000 psi	Yield Strength (0.2% offset), 1000 psi	Elongation, %
1	199	143	11.8
2	193	144	9.0
Typical(b)	175	110	15.0

(a) Solution treated 4 hours at 1975 F, air cooled; then aged 24 hours at 1150 F, air cooled; then aged 16 hours at 1400 F, air cooled.

(b) Properties reported in Utica Metals Bulletin. Source: Toaz, Davies, and Johnson, "Aircraft Superalloys by Powder Metallurgy", Progress in Powder Metallurgy, 152, 16, 1960.

## REFERENCES

1. Boichenko, M. C., Continuous Casting, orig. 1957, translated by L. Herdon and R. Servell, Butterworths, London, 1961.  
Bride, D. L., Continuous Casting, AIME, Interscience Publishers, New York City, 1962, 255 pages.  
Schwarzmeir, W., Stranggieszen, Berliner Union GmbH, Stuttgart, 1957, 225 pages text and 76 pages patents (1271 patents).  
Continuous Casting, British Iron & Steel, Special Report No. 76.  
Bailey, G. I., and Mantle, E. C., The Continuous and Semi-Continuous Casting of Copperalloy Billets and Rolling Slabs, J. Inst. of Met., 91, 1963, 385-391.
2. Steel, March 30, 1964, 132.
3. Wyman, B. H., Industrial & Engineering Chemistry, 55 (12), Dec. 1963, 53-59.
4. Steel, March 30, 1964, 133.
5. Engineering, London, 1905, 68.
6. Franszen, H., and Frauszen, N., Zt. Metallkunde, 53, 1962, 78-85.
7. Planseeberichte fur Pulvermetallurgie, 7, 1959, 102-116.
8. Davies, G. F., J. Metals, May, 1963, 352-354.
9. J. Metals, 10 (11), 1959, 731-734.
10. Fraser, R. W., Evans, D. J. I., and Mackiw, V. N., paper to be presented at Journees Internationales du Cobalt, June, 1964, Brussels, Belgium.
11. Iron Age, May 3, 1962, 73-75.



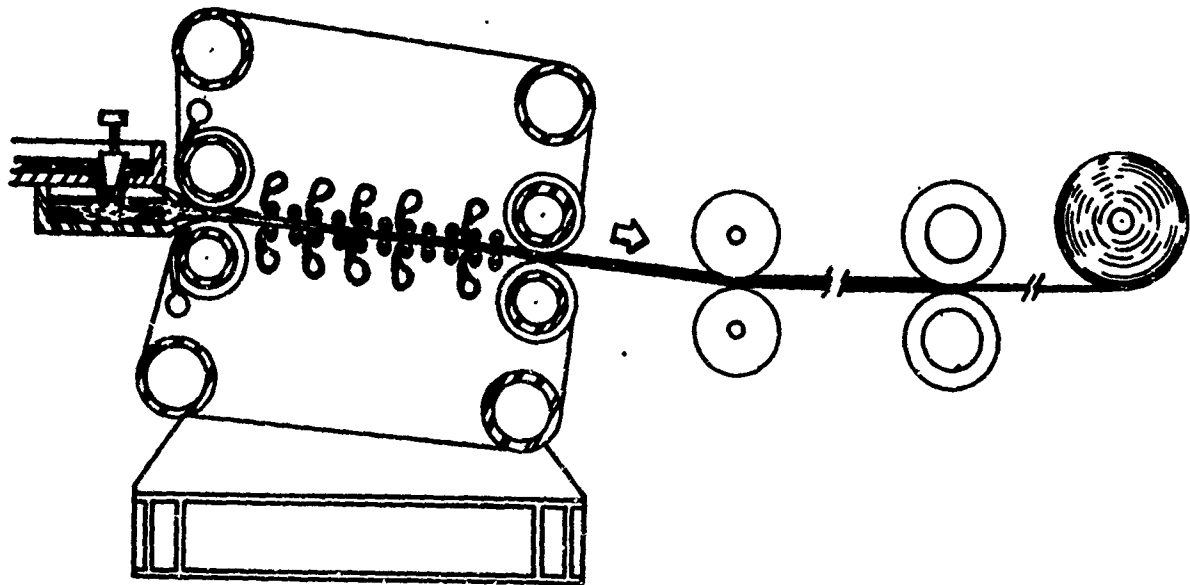

Figure 1 Hazlett Strip-Casting Process

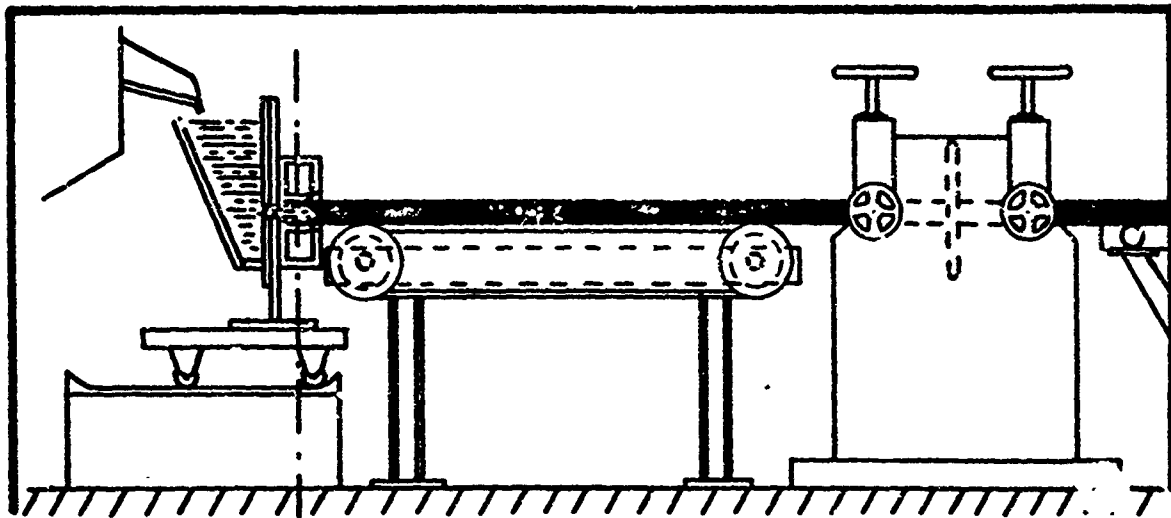

Figure 2 General Arrangement of the Uginé-Venthon Process for Horizontal Casting

## DESIGN OPTIMIZATION THROUGH MATERIALS RESEARCH

by

M. A. Steinberg

## 1. NEW METHODS IN MATERIALS RESEARCH

The traditional viewpoint in materials applications has been to cleverly adapt (and sometimes compromise) a design concept to the unyielding properties of the materials available, to cut and pare performance goals to the size of the often ill-fitting mold of conventional materials. In the aerospace field, as new and more demanding missions present more and more stringent requirements to the materials engineer, this traditional approach has had to be modified. Now materials men are faced with the problem of designing "to order" entirely new materials or combinations of materials with properties suitable to meet service conditions within the time schedule for system development. Materials are "tailor-made" with an end-service orientation, and each application may have its own unique solution with respect to materials and design.

We may characterize the older design procedure as linear, that is, it proceeded stepwise from known properties of proven materials, forced modification of preliminary design to suit materials available, and, through a trade-off process, resulted in a final design adapted to use of pre-existing materials. The newer procedure makes use of a more simultaneous method of attack. From extrapolations of properties of existing materials or combinations of materials, materials requirements are set at the initiation of a project. Then the researchers turn their efforts to satisfying these requirements while other elements of systems design are progressing. The complexity of materials problems in the aerospace industry stems from the fact that these requirements combine exacting and often unusual combinations of properties with short lead-times for research and development. Major difficulties arise because design concepts and critical environmental factors are still foreign to most members of the materials field.

The problem is further complicated by an incomplete or erroneous understanding of the basic properties and capabilities of new materials on the part of the user -- the design engineer. Close coordination between the activities of structural designers and materials specialists is essential to any materials research and development program. A harmonious working arrangement is necessary among producers, users, and government sponsors in planning and timing for future needs.

The transition from conventional aircraft construction to missiles and spacecraft characteristic of the past decade has spurred the development, through the "simultaneous" processes mentioned above, of high temperature structural materials as well as a number of newer developments in the fabrication of light-weight structures.

Weight is at a premium in every endeavor in this industry. Structures must be designed to the lightest possible weight at a supportable cost and equal to the capabilities of all of the other components of the system -- the power plant, guidance controls, propulsion, and payload. To accomplish this, the materials engineer must know the real value of each pound saved as well as knowing how material, fabrication, and installation costs vary from material to material.

Misleading results can be obtained in design optimizations for minimum weight if improper comparison parameters are used. W. R. Micks of Rand Corporation (Ref. 1) gives an example of this in a comparison of two materials for use in a narrow column. With given dimensions for a square cross section tube, a column of A Z31M magnesium (FS-1H) has a buckling strength of 2509 pounds. When a column of 7075-T6 aluminum is designed to the same weight, length, and cross-section proportions, the failure load for this equal-weight aluminum column is found to be only 1730 pounds.

Taking these facts, however, to mean that magnesium is 1.44 times as efficient, on a weight basis, as aluminum is erroneous, as Micks points out. In the first place, the geometric proportions of the aluminum column should not have been made the same as the magnesium, since the optimum aluminum column would have different proportions. When this error is corrected, the ratio of magnesium to aluminum strength now appears to be only 1.28. These comparisons are shown in the first three bars of Fig. 1.

A further error in the comparison is that the wrong parameter is being used for comparison. Strength, which the designer does not want to maximize, has been chosen instead of weight, which he does want to minimize. The strength is assumed to be a constant requirement of the mission with the weight to be made as small as possible. If an optimum aluminum column is designed to have the same strength as the magnesium column, the ratio of aluminum weight to magnesium weight is 1.13 as shown in Fig. 1.

To illustrate further how the comparison depends on the proper specification of the design, if the structural job, as measured by the ratio of the design load to the square of the effective pinned-end length over which the load is transmitted, is changed from  $P/L^2 = 1.0$  psi to  $P/L^2 = 100$  psi, we find that the relative efficiencies have been reversed, as shown in the right-hand bars of Fig. 1.

This example of design optimization depended on a proper comparison between properties of available materials. The more usual case is likely to involve requirements for materials properties which cannot be immediately met by any

available commercial material. The approach to this problem is an optimization study, as is done in systems work. Such a study is undertaken at the very beginning of a program in the generalized design or system study where the materials characteristics required are determined in terms of the relative importance to the need. This then delineates the level of materials research and development to be supported so that, in the development of the system, needs will be fulfilled in the proper time-scale position.

Thus, materials engineering is vitally concerned with preliminary design, a point worth dwelling on, since, to me, it is the one which differentiates the interdisciplinary approach to materials science from materials engineering.

In the broadest sense, materials engineering is intimately interwoven with mechanics (including mathematics), thermodynamics, aerodynamics, and structures, as well as with electronics or solid state physics. It is the close relationship in these fields that makes materials engineering a true engineering entity.

In fact, the linking of "feedback" is much stronger in these interdisciplinary fields than it is with physics of solids, or structure on an atomistic scale. It is from his fellow engineering colleagues that the materials engineer first gets a look at the environment problems that his materials will be faced with, and under which conditions they must operate. In general, the requirements are such that, in their delineation, a real language disability between materials specialist and the engineer (not designer) in the analytical fields can exist until one completely understands the other. Only when such a gap is bridged can innovations arising from materials science of elsewhere be brought to useful end-item hardware.

Obviously, research cannot be done on every material. Micks, of the Rand Corporation (Ref. 2) has recently written about materials engineering in the systems concept, delineating a number of steps to help decide which direction materials R & D should take to meet the material demands of a new major weapons system. He has suggested using the generalized design or systems study -- the method of operation for the preliminary designers or advanced system study engineers -- for determining the actual materials research and development to be conducted, and has indicated the steps shown in Table 1.

Utterly confusing to a materials engineer is to embark on a materials program for end-item application only to have the parameters change, causing a need for a continuously varying materials input for the end-item. Again, Micks has drawn up relationships to use as a guideline. Table 2 presents the kind of information with which a materials engineer and the aerothermo-structures researcher are constantly embroiled in satisfying the systems engineer or designer.

Many examples could be given of the tailor-making of materials or materials combinations to the requirements dictated by missile or spacecraft systems requirements. A few of these examples will be outlined later to show how this principle of "materials designed to order" applies to a wide range and variety of

Table 1

**STEPS TO EVOLVE AN R & D MATERIALS PROGRAM  
FOR A MAJOR WEAPONS SYSTEM (Ref. 2)**

1. Form the initial concept and advanced design of the system.
2. Determine how materials capability influences the end-item capability.
3. Derive from these interactions the information that is relevant to materials R & D planning.
4. Derive from this information the appropriate research directions and goals.
5. Form research and development programs that properly reflect these research directions and goals.
6. Judge and decide which programs to implement and at what relative levels of effort.
7. Conduct the actual research and development activity.

Table 2

**PARAMETRIC ANALYSIS OF COMPONENT AND  
MATERIALS CAPABILITIES AGAINST MISSION CAPABILITY (Ref. 2)**

1. Which vehicle components are the most important in determining the overall vehicle capability?
2. What are the most important materials parameters affecting the design of these components?
3. What ranges of parameter values are of interest?
4. In what range of parameter values is the greatest improvement obtained in the vehicle capability as a result of incremental improvements in the materials?
5. What are the relative payoffs for the various materials improvements?
6. What minimum improvements in the materials are necessary to provide an interesting improvement in the end-item?

types of materials. Possibly one of the most important such examples of this process in action is the design of thermal protection materials for reentry systems to which much work has been devoted in the past few years.

## 2. THERMAL PROTECTION MATERIALS FOR REENTRY STRUCTURES

The success of the many aerospace programs is dependent on the development of lightweight high temperature structures. To consider the problems involved in the design of high temperature structures, the following questions must be posed:

- \* Where may these configurations be applied?
- \* What is the minimum weight consideration?
- \* What materials are compatible with the design environment?
- \* Which methods of analysis are reliable in lightweight high temperature structural design?

### 2.1. Basic Concepts of Reentry Vehicles

One of the environments that is of interest for the large majority of high temperature applications in the aerospace field is reentry. Spacecraft entering from orbital and superorbital trajectories encounter severe heat pulses as well as maneuvering and deceleration loads. The conventional approach to the structural design of such vehicles is a load-carrying metallic structure with heat blocking materials provided where necessary. Re-use of such structures is, in most cases, not possible.

The aerodynamic heat input to a reentry structure is expressed as an instantaneous heat flux ( $\dot{q}$ ) in Btu/ft<sup>2</sup> sec and a total heat input ( $Q$ ) in Btu/ft<sup>2</sup>. From a materials requirements standpoint, the instantaneous heat flux ( $\dot{q}$ ) and the duration of the heat pulse are the most important considerations. These determine the optimum thermal protection system and the required materials characteristics. The maximum temperature attained depends to a large extent on the heat flux and the surface emissivity. High values of total heat input ( $Q$ ) are not necessarily critical, since this is a time-integrated function. Most of the total energy can be stored or dissipated by the system.

The following two approaches are used in the design of thermal protection

systems for reentry structures:

- \* Absorptive Systems -- heat flux is accommodated by mass-transfer heat absorption (ablation) or by storing heat during exposure (heat sink).
- \* Radiative Systems -- heat is dissipated to the atmosphere by radiation from a hot surface.

Absorptive systems usually are limited by weight considerations to short-time use and are best suited for very high heat flux ( $\dot{q} = 2000 \text{ Btu/ft}^2 \text{ sec}$ ). Radiative systems are limited by melting points of heat shields and structures to relatively low heat fluxes ( $\dot{q} = 200 \text{ Btu/ft}^2 \text{ sec}$ ) for long-time use or to higher fluxes for short-pulse heating cycles. Either of these methods, or a combination of both methods, may provide the optimum system for a given vehicle.

Reentry vehicles (Fig. 2) are divided into three major classifications based on the escape velocity at the start of reentry: (1) suborbital (1800 to 24,000 fps), (2) orbital (24,000 to 26,000 fps), and (3) superorbital (36,000 fps). The ballistic missile nose cone is the most familiar example of a suborbital vehicle.

Peak heating rates ( $\dot{q} = 1200 \text{ to } 3000 \text{ Btu/ft}^2 \text{ sec}$ ) are the highest for any class of vehicles, but the maximum heat pulse duration is short (1 min). Total heat input ranges from 10,000 to 30,000  $\text{Btu/ft}^2$ . Ablative and heat-sink materials are used widely in these structures.

Orbital vehicles, such as existing manned and unmanned reentry capsules and boost-glide vehicles, sustain the lowest instantaneous heat flux ( $\dot{q} = 200 \text{ to } 500$ ) over a much longer duration than those of ballistic reentry vehicles. The total heat input is similar to that for ballistic reentry, depending on the range. As previously mentioned, radiation cooling with insulated structures and heat shields provides the most efficient method of thermal protection for these vehicles.

Superorbital vehicles that must reenter the earth's atmosphere on return from a space mission present one of the most critical problems in thermal protection. Instantaneous heat fluxes approach those for ballistic reentry ( $\dot{q} = 200 \text{ to } 1100 \text{ Btu/ft}^2 \text{ sec}$ ) and must be sustained for long time periods. The total heat input ( $Q = 50,000 \text{ to } 300,000 \text{ Btu/ft}^2$ ) is highest for any class of vehicles. A combination of absorptive and radiative thermal-protection systems will most likely be required.

A typical mission flight corridor for a winged reentry vehicle with a specific  $W/C_dA$  is shown in Fig. 3.

Within each class of reentry vehicles, considerable variation in materials requirements is met, depending on vehicle design and nature of the flight.

## 2.2. Materials Considerations

As an illustration, let us consider the process of defining materials requirements for reentry vehicles, specifically those vehicles that do not have specific lifting and control surfaces such as wings and fins, and which are characterized by a lift-to-drag ratio of less than 0.5. Design of this class of vehicles would first of all be governed by the environment as generally described in Fig. 2. Next the complete range of environments likely to present problems must be examined for the subsystems of interest. For these reentry systems the aerodynamic thermal environment is likely to be a severe problem for heat shields, radomes, insulation, and sealants and a lesser one for primary load-bearing structures and internal structures. The solar thermal environment as well as solar and nuclear radiation will also adversely affect radomes and transparencies. Stresses due to static, cyclic, acoustic, accelerative, and thermal factors will likely be a problem for heat shields, load-bearing structures, and to a lesser extent, radomes and sealants. Insulation would not be affected. Impingement phenomena (meteoroids, sputtering) should affect only the heat shields and radomes. High vacuum is not likely to be a problem for any of these sub-systems. Nuclear radiation adversely affects heat shields, radomes, and sealants.

Based on this environment, we must then attempt to determine the most important parameters governing the various subsystems of this type of vehicle. Table 3 shows those properties which have been judged to be of primary and secondary significance for reentry vehicle performance. Having determined the significant properties we next specify the ranges, if known, over which these properties may vary.

A complete specification would include the range of properties required for all the materials to be used in the system, based on the expected environments to be encountered.

Once the required materials have been described as completely as possible, the design of optimum materials to meet these requirements can proceed. Two examples will be given here of thermal protection materials developed for reentry structures -- a thermal protection composite for heat shields, radomes, etc., and coated refractory metals for leading edges of lifting hypersonic vehicles, etc. The first example is that of Lock-Heat, a family of composite materials for thermal protection systems based on inorganic bonding of various refractory fibers, developed by Lockheed Missiles & Space Company. The material system can be modified for each application, to encompass a wide range of physical and thermal properties.

The fabrication process possesses great versatility in the placement of the various strata, i. e., the structure, insulation, porous refractory skeleton, and ablative-loaded refractory skeleton may be fabricated in any sequence. Moreover, the types and amounts of the various ingredients can be adjusted to provide optimum performance for minimum weight and most significantly they can be tailored to specific design requirements.



Table 3

**SIGNIFICANT MATERIALS PROPERTIES AFFECTING  
REENTRY VEHICLE PERFORMANCE**

Heat Shields

Ultimate Strength  
Yield Strength  
Ductility  
Stress Rupture  
Toughness  
Conductivity  
Specific Heat  
Emissivity and Absorptivity  
Effective Thermal Capacity  
Melting, Boiling Points  
Corrosion Resistance

Internal Structure

Yield Strength  
Elastic Modulus  
Toughness

Radomes and Transparencies

Ultimate Strength  
Elastic Modulus  
Dielectric Constant

Insulation

Conductivity

Primary Structure

Ultimate Strength  
Yield Strength  
Elastic Modulus  
Toughness  
Oxidation Resistance

Sealants

Ultimate Strength  
Elongation  
Creep

The properties requirements are given below for one of the subsystems of Table 3.

Ablative ShieldsKey Requirements:

Heat of Ablation ( $q^*$ ) = 15,000 Btu/lb  
(does not include re-radiation)  
Structural integrity at reactive temperatures  
Low thermal conductivity  
( $< 0.8 \times 10^{-5}$  Btu/hr- $^{\circ}$ F-ft)

Environmental Conditions:

Space environment: 1 to 100 r/hr  
dose rate  
Meteoroids: bombardment at velocities up to 72 km/sec up to 4000 km altitude  
Entry environment: high heating rates ( $> 2000$  Btu/ft $^2$ -sec)

Applications of interest with the Lock-Heat design capability include heat shields for missile and satellite reentry, radomes for high temperature use, exit cones for rocket motor components, and insulation of rocket components. Radar cross-section reduction and vulnerability reduction are obtained through controlled energy absorption. Figure 4 shows the backface temperature response of a Lock-Heat composite exposed to long time heating.

For radomes on missiles and spacecraft, the high thermal loads associated with reentry require both ablative cooling for high intensities and insulation for long soak times. A noncharring ablator is to be incorporated in a thin outer shell, while insulation will be provided by an inorganically bonded fibrous quartz network of fairly low density. The dielectric constants of the inner and outer shell will be balanced to a particular ratio prescribed by electromagnetic design considerations for the two frequency ranges to be transmitted. This approach is believed to be unique in current radome designs. Further applications of this versatile technique can be expected in the future.

A summary of mechanical properties determined for a specific Lock-Heat formulation is presented in Fig. 5, indicating modulus as well as tensile and compressive strengths at room and elevated temperatures. It is immediately obvious that Lock-Heat possesses certain physical properties at elevated temperatures which cannot be achieved by homogeneous materials. Consequently, under some circumstances, Lock-Heat materials can be considered for use as load-bearing structures and can also provide for mechanical attachment to sub-structures.

Refractory metals and alloys will be used most extensively in high supersonic and hypersonic cruise and hypersonic boost-glide or reentry vehicles. Limited local applications will be made in certain types of missiles and boosters. Development of these metals is required in the material forms and possessing the properties indicated under environments specified below.

The materials will be used on supersonic and hypersonic cruise vehicles and hypersonic boost-glide and reentry vehicles on their lower surfaces, leading edges, and nose cones under conditions of heat flux ranging from 5 Btu/ft<sup>2</sup>-sec to as high as 200 Btu/ft<sup>2</sup>-sec. The corresponding materials equilibrium surface temperatures will range from 2000 to 4500°F. Exposure times will range from 300 hours at 2000°F to 25 hours at 4500°F. Transient heat fluxes as high as 16,000 Btu/ft<sup>2</sup>-sec will be experienced on the nose and leading edges of high performance missiles.

Coated refractory metals may be used for these applications and for portions of the structure adjacent to the nose. However, the short-time duration of the heat pulse will tend to favor the use of ablatants. Some conditions which will influence designs and choice of materials are:

- \* Maximum loads will not occur at the same time as maximum temperatures.
- \* Fatigue, creep, and stress rupture from cycling temperatures and stress will be critical in design.
- \* Acoustic levels of 165 to 185 dB at the power plant to 205 dB on the surfaces will occur at high speeds and low levels.

The material forms required will be sheets less than 0.060-in. -thick, sandwich structures in foil gages  $\sim 0.005$  in.; extrusions may be required for low altitude cruise vehicles. For fastening and joining, welding and brazing will be favored but mechanical fasteners will also serve. There will be little use of castings, but forgings, weldments, and pressed and sintered parts will be used at local strong points (Ref. 5).

Properties that are required in these materials are good ductility, resistance to crack propagation, stress corrosion, and weldability. In addition, these materials must have good oxidation resistance or compatible coatings must be available for protection from low partial pressure oxidation. Besides the pure metals, alloys with good formability and which can be resistance-welded should be developed. Some desirable properties are elongation greater than 4% and ductile-to-brittle transition temperature less than  $-100^{\circ}\text{F}$ .

Because of the long heating times and heat flux levels encountered, special materials problems exist at the leading edges of the aerodynamic control surfaces (nose, wings, and fins). If a refractory material is considered, it is readily found that radiation cooling results in radiation equilibrium temperatures which can easily exceed  $3500^{\circ}\text{F}$ , a temperature regime which is much higher than can be tolerated by all but a very few materials.

Because of the high temperatures produced at the leading edges of control surfaces of hypersonic lifting vehicles and their sustained flight of an hour or more through the earth's reentry corridor, the penetration of the heat into the interior of the thermal shield and oxidation of the surface can occur. These conditions present problems in materials selection and design for these structures. The backface temperature of the heat shield must remain sufficiently low so that there is little danger of thermal failure of the attachments and the supporting structure. The material must resist surface oxidation which could cause shape changes that would alter the aerodynamic characteristics of the control surfaces (Fig. 6).

Success in using coated refractory metals requires careful matching of design features, manufacturing sequences, and service requirements to the characteristics of available coating systems. No one system has universal applicability since many factors other than temperature govern the basic performance and useful life of coated parts. Experience in the aerospace industry has shown that adequate reliability can be achieved in the scale-up of coating systems from the laboratory to production hardware. However, this can be done only within the performance capabilities of a given system as established in relation to a specific design and end-item use. Even the best of coating systems has an imposing number of limitations with respect to design, manufacture, and use. Most of the problems in using coated refractory metals result from a failure to recognize and design within the basic performance capabilities and inherent limitations of these materials.

The available performance data for specific coating systems are difficult

to evaluate due to lack of standardized testing procedures. Although coating compositions are standardized, uncontrolled variations in specimen geometry, specimen preparation, coating thickness, and testing conditions have produced a somewhat confusing picture of performance capabilities. Although the situation has improved considerably in the past year, a vast amount of work remains to be done to accurately and adequately characterize these materials. Available information should be treated in generalized terms and should not be considered as design criteria.

The major limitations in the use of coated refractory metals arise from variations in the basic factors that control useful life and mechanical properties. The more important of these factors are operating temperature, effective coating thickness, effective substrate thickness, and atmospheric pressure and composition.

The relation of coating life to temperature and initial coating thickness and the similarity in average life of all silicide-base coating systems suggests that a common factor controls overall performance. Studies of  $\text{MoSi}_2$  coatings on molybdenum at Lockheed Missiles & Space Company have resulted in a new interpretation and more complete understanding of coating behavior that may provide the key to the problem of predicting coating life. It now appears that useful life may be governed by the time required to convert the coating from the higher silicide ( $\text{MoSi}_2$ ) to the next lower silicide ( $\text{Mo}_5\text{Si}_3$ ) by diffusion.

Figure 7 indicates this change taking place as a function of time at elevated temperature (Ref. 6). The predicted lifetimes of  $\text{MoSi}_2$  coatings are shown in Fig. 8 (Ref. 7).

### 3. THE GLASS FILAMENT-EPOXY RESIN ROCKET MOTOR CASE

The factors involved in selecting the overall design features of a rocket motor for a specific missile function are established at the time the missile system is conceived. The requirements are based on the state-of-the-art and its projected growth throughout the period of motor development. In transforming target values into reliable engine components, sound judgment is the key in deciding when advanced technology can be incorporated into an operational system.

Once a choice of propellants has been made, the motor case and inert parts (nozzles, liners, and insulation) necessary to give minimum weight and reliability can be analyzed and the size and scope of the supporting development program measured to make sure that the projected values of strengths, and hence weights, are realistic in terms of deliverable hardware.

Let us consider a solid propellant rocket motor development for a missile system designed in 1960 to be operational in 1965, projecting 1960--1965 growth in terms of state-of-the-art and improvements in one area: the motor case (Ref. 4). The motor cases of interest are complicated by a number of off-center openings, i. e., for thrust reversal, nozzles, and igniters. Based on projected weights required and money available for development, of what material should we make the case and of what magnitude should the development effort be?

Initially, the rocket industry made solid propellant motor cases out of steel. As increased performance goals demanded lighter weight cases, steel case strengths were increased, and the lower density high-strength titanium alloys were given serious consideration. Finally, still lower density glass-filament-wound cases came into use. Motor cases of these three structural materials were analyzed in relation to their 1960 strength and weight. Forecasts of expected improvement in the state-of-the-art were made and considerations other than strength and weight (i. e., cost) which were expected to influence selection of a structural material for an advanced solid-weight propellant motor case were also evaluated.

Improvements expected in 1960 for incorporation into production hardware by 1964 and beyond are shown in Fig. 9. The projected values are presented on a strength-index basis. The strength used is the membrane hoop stress developed in the cylindrical section of a motor case as a result of the proof hydrotesting of each chamber. The strength index is the value obtained by dividing the stated strength value by the density of the structure. All values presented are for chambers without thrust reversers, and some weight penalty will be necessary for chambers with thrust reversers in a forward dome.

### 3.1. Filament-Wound Glass

A 1960 index for glass of  $0.858 \times 10^6$  was obtained from the then current proof hydrotest stress of 60,000 psi, the then current density of 0.070 and glass filament strength of 250,000 psi, and a burst factor of safety  $\alpha = 1.25$ . A 1961 index of  $0.943 \times 10^6$  was obtained from an improved proof hydrotest stress of 66,000 psi (reflecting improvement in winding inefficiency factor from 43 to 14%) and the same values of the other parameters. Without additional reduction of winding inefficiency factor, a 1964 index of  $1.058 \times 10^6$  is obtained from an improved proof hydrotest stress of 76,000 psi (resulting from an improved glass filament strength to 270,000 psi and a reduced burst factor of safety of 1.20) and an increased density of 0.072. A 1966 index of  $1.097 \times 10^6$  is obtained from an improved proof hydrotest stress of 80,000 psi (resulting from a further improvement in filament strength, some improvement in winding efficiency with such improved design concepts as large, single-end openings with winding terminating short of the polar region, and use of large metal inserts of reduced weight and reduced burst factor of safety of 1.176) and an estimated density of 0.073.

The projected strength-index values are plotted in Fig. 9 for the years in

which production glass cases are expected to be ready for use with propellant.

### 3.2. Titanium

A 1960 index for titanium of  $0.776 \times 10^6$  was obtained from the 135,000 psi heat-treated yield strength currently being produced with the 6 Al 4V alloy with a 1.25 yield factor of safety (proof hydrotest stress 124,000 psi) and the 0.160 density of this alloy. A 1961 index of  $0.915 \times 10^6$  was obtained from an improved proof hydrotest stress of 160,000 psi attainable with the B 120 VCA alloy at a yield factor of safety of 1.15 and the 0.175 density of this alloy. The reduced yield factor of safety was projected on the basis of an expected improved product reliability. A 1964 index of  $1.075 \times 10^6$  is obtained from an improved proof hydrotest stress of 188,000 psi (resulting from an improved heat-treated yield strength of 180,000 psi now being developed and expected to be in production use in 1964, and a further reduced yield factor of safety of 1.10) and the 0.175 density of the B120 VCA alloy. A 1966 index approaching  $1.1 \times 10^6$  is hopefully anticipated with a slight improvement in proof hydrotest stress to 192,500 psi (resulting only from an improved heat-treated yield strength without further reduction in the yield factor of safety). The density is unchanged at 0.175. These strength-index values are plotted in Fig. 9.

### 3.3. Low Alloy High Strength Steel

A 1960 index for steel of  $0.651 \times 10^6$  was obtained from the currently used heat-treated yield strength of 200,000 psi and the currently used yield factor of safety of 1.25 resulting in a proof hydrotest stress of 184,000 psi (density is 0.283). A 1961 index of  $0.866 \times 10^6$  was obtained from an improved proof hydrotest stress of 245,000 psi associated with a 1.15 yield factor of safety and a 245,000 psi heat-treated yield strength. A 1964 index of  $1.035 \times 10^6$  is obtained from an improved proof hydrotest stress of 293,000 psi associated with a 1.10 yield factor of safety and a 280,000 psi heat-treated yield strength. A 1966 index of  $1.09 \times 10^6$  is hopefully anticipated with a slight improvement in proof hydrotest stress to 308,000 psi associated with the 1.10 yield factor of safety and a 295,000 psi heat-treated yield strength. These strength-index values are plotted in Fig. 9.

### 3.4. Results

The question now arises: what have been the results of research and development aimed at meeting materials requirements set in 1960?

By 1965, the predictable development of the three chamber designs considered will lead to a situation where the strength-to-density ratios of all three materials, based on hoop stresses in cylindrical vessel bodies under ideal conditions, will be indistinguishable for all practical purposes (close to  $1.1 \times 10^6$ ).

As shown by the actual strength index values plotted also in Fig. 9, our research and development, end-item oriented to a low-cost minimum-weight reliable glass-epoxy chamber, has led to 1964 properties slightly surpassing the projected goals. Actual values of proof hydrotest stress of 78,000 psi are being achieved in production of solid-propellant motor chambers today.

Development programs instituted in 1960 on filament-wound composites have covered (1) numerically controlled filament winding, (2) process variables such as winding tensions, (3) prepreg treatments, (4) resin investigations, (5) cure cycles, (6) mandrel designs, (7) optimum case design, (8) closure problems, (9) moisture pickup, (10) dimensional changes and tolerances, (11) and finally, the development of newer high strength glass, the Owens-Corning S-994, which demonstrates 30% improved strength properties over E-glass filaments. Based on these programs, the projected targets for 1965, estimated in 1960, can be more than adequately met.

The selection of the construction material for a specific motor case design must also take cognizance of other factors such as external loads, storage environment, aerodynamic heating, internal wall temperatures during combustion, reliability and costs. On cost alone, a choice in 1960 could have been made based on projected strength/density ratios being projected as near equivalent in 1965 production, with ratio of costs being roughly in the following order: Ti/glass  $\approx$  10/1 and steel glass  $\approx$  4.5/1, on a cost basis. These are only rough-order-of-magnitude estimates.

Development costs as well as production costs may likewise be expected to be greater for metal cases than glass cases; however, the reliability of glass cases may not be as high as desired because of the lack of understanding of a number of factors pertinent to composite structures:

- \* Bond degradation -- shear strength loss  $\alpha$ . cyclic loading, heating (aerodynamic, etc.)
- \* Effect of moisture absorbed during storage
- \* Shear strength of the bonding resin in the presence of stresses due to external ground handling loads
- \* The effect of resin curing process on the dimensions and shapes of the case and on residual stresses
- \* Methods of flaw inspection for these composite structures

These questions have dictated the supporting research and development programs so that the glass filament-wound motor case could be tailor-made with end-service orientation in mind.

Perhaps, the greatest improvement in the state-of-the-art in the use of filament-wound structures for solid propellant motor chambers came about primarily from the interaction of materials research with design. The end goal, a minimum weight structure, could not have been obtained by research on materials alone, even with an all-out effort on the development of new glass compositions and newer resin systems. Instead, it resulted from the interaction of optimization in design and materials research, and with the analyses carried out to understand all of the pertinent factors of glass-chamber manufacture in order that the full properties of glass fibers could be obtained in the final end-item vessel. Since filaments carry load only along their axis (but not at any angle to their axis), minimum-weight glass chambers will be achieved when the industry is able to wind filaments exactly in the axis along which stresses are produced, thereby obtaining an isotensoid body. At burst pressure, all filaments are stressed to filament ultimate strength and all fail simultaneously. This condition has not yet been attained with closed-end vessels; it can be done with open-ended cylindrical bodies.

End domes have been the major stumbling block in attaining the reduced-weight potential of filament-wound glass chambers. Much research has been expended in the study of the end-dome contour. Because filaments on end domes cannot yet be placed to align exactly with developed stresses, more filaments than the required minimum are necessary. Since extra filaments on end domes become extra filaments longitudinally on the cylindrical portion of a chamber, full filament strength is not utilized in the longitudinally wound filaments. It was common, about a year ago, to have chambers in which hoop-wound filaments attained essentially 100% filament strength at burst while longitudinal filaments attained only 65% filament strength. Resin content of the composite did not have a very large effect.

When final modifications of end-dome contour were accomplished for optimum utilization of the glass fibers, strength utilization in all fibers more nearly approached 100% than any other design, permitting weight reductions.

#### 4. LIGHTWEIGHT, DUCTILE BERYLLIUM-ALUMINUM ALLOYS

Another example in which advanced requirements for aerospace missions have directed the development of new materials is the series of new beryllium-aluminum alloys, designated Lockalloys, developed by Lockheed Missiles & Space Company. In this case the requirements were not specific to one missile system but were general to a variety of potential vehicles (Ref. 8).

Theoretically, beryllium with its high Young's modulus of  $42 \times 10^6$  psi and low density of  $0.066 \text{ lb/in}^3$  is one of the best candidate materials for structural applications in missiles and spacecraft where compression buckling and crippling



is likely to be encountered. The serious drawbacks of pure beryllium are, of course, its brittleness and extreme sensitivity to surface damage. The results are poor fabricability and machinability. These serious objections have been largely overcome in the ductile Lockalloy, which retains much of the favorable elastic modulus and density of pure beryllium.

Lockalloys consist, essentially, of a fine beryllium network embedded in a matrix of ductile aluminum. The practical heat treatment and processing schedules give an extremely wide range of microstructures, and, consequently, an unusually large range of mechanical properties. Laboratory studies reveal that significant changes ( $\pm 10^6$  psi) in Young's modulus can be obtained by heat treatment. These changes can be related quantitatively to the beryllium particle size and its complexity of shape. A further important discovery is that these alloys also manifest strain-aging behaviour.

Figures 10, 11, and 12 are comparisons of the elastic weight index versus composition for the Lockalloys and for other important competitive alloys. The elastic weight index, as used here, is the ratio of the density of the alloy to the square root of its modulus. The lower the value of the elastic weight index, the more suitable is the alloy. Beryllium has a value near 100, whereas aluminum and its alloys are near 300. The lockalloys, both in the rolled and annealed condition, have intermediate values around 140. The position of typical magnesium alloys is indicated by the squares along the right-hand side of the graph.

A comparison of the mechanical properties of Lockalloys is given in Fig. 13. The bar graphs depict the relative values of tensile strength, yield strength, bend angle, density, and elastic modulus for the Lockalloys, beryllium, magnesium, and aluminum. This method of presentation shows quite clearly the favorable overall properties of the Lockalloys.

This newly developed structural composite alloy offers: (1) significant weight savings over Mg and Al alloys in compressively loaded structure and (2) advantages over Be in the form of improved useful ductility; relative insensitivity to surface damage as compared to Be; freedom from tedious chemical etching after machining; and improved machinability, weldability, fabricability, and forming characteristics which should result in significantly lower installed cost. The range of modulus, strength, density, and ductility available in Be-Al alloys presents a wide variety of previously unattainable trade-offs to the spacecraft designer, thus enabling him to meet many advanced system requirements.

## 5. IMPREGNATED REFRACTORY METAL ROCKET MOTOR NOZZLES

One of the most severe environments with which we must cope in the aerospace industry is that posed by the very hot and corrosive gases of the rocket motor exhaust. Materials suitable for use as nozzles for directing the flow of these gases must meet a unique combination of rigorous requirements including the following:

- \* Extreme stability of the structure (i. e., virtually zero change of the critical dimensions due to high pressure and temperature applications)
- \* High resistance to thermal shock during heating and cooling to prevent structural failure of the component during service
- \* Fabricability, including machinability, on an economical production scale
- \* Optimum reliability and reproducibility of relatively large sized components

When these stringent specifications were applied in the case of a recent nozzle development program, the choice of materials became by necessity extremely limited (Ref. 9). Tungsten and tungsten composite materials were believed to have more potential for meeting requirements than other high temperature resistant materials of appropriate physical and chemical properties. However, the requirements could not be completely satisfied with the materials and processes at that time available. A materials development design and process optimization program had to be initiated to bring to the stage of commercial availability materials with the desired combination of properties for nozzles by the time other parts of the complete system were ready.

With the application of infiltrated tungsten, the program became successful. Billets weighing up to 200 pounds of pressed and sintered tungsten of less than theoretical density (80%) are infiltrated with a metal of high thermal conductivity and high vapor pressure, such as copper or silver. Although much higher in cost, silver is preferred over copper because it best fits the infiltrant requirements of a low boiling point under the softening temperature of the tungsten, a satisfactory temperature span in the liquid state, a high heat content in the transformation from a solid to a vapor, and complete lack of reaction or alloying with the tungsten.

Nozzles made from silver-infiltrated tungsten have shown no erosion in full-scale prototype firings with high-energy propellants. Some thermal cracking of the outer diameter of the throat inserts has been observed, but the cracking has

not hampered nozzle performance. However, as a result of improvement in manufacture, thermal cracking has been reduced to an allowable minimum. It is believed that transpiration cooling of the infiltrant, resulting in film blocking in the boundary layer of the exhaust, accounts for the superior behavior of the infiltrated tungsten nozzle inserts.

To achieve optimum end-use performance of this composite, all of the manufacturing processing variables must be rigidly controlled and carefully optimized. Two of these variables were found to have significant bearing upon the ultimate properties. One of these is the tungsten powder particle size, which apparently influences the ultimate matrix density, permeability, tensile strength and tensile modulus of elasticity. The other is the infiltration temperature and infiltrant feeding technique which significantly influence the composite tensile strength, which must be about 33,000 psi at 1500°F, and the thermal conductivity, which must be high enough to minimize thermal stresses. Figure 14 compares tensile strength of infiltrated tungsten with the pressed and sintered tungsten matrix while Table 4 gives the mechanical and physical properties of infiltrated tungsten at various temperatures.

With the demands for longer range in future missiles, longer burning times, higher mass flow rates, higher temperatures, and consequently higher energy propellants will be required. Required will be lighter-weight constructions of nozzle components capable of withstanding the severe environment. The state-of-the-art of materials technology at this time is such that a major breakthrough in materials development for nozzles is required to produce components of low chemical reactivity, high erosion and thermal stress resistance, and low weight for service to temperatures as high as 7000 to 8000°F.

## 6. CONCLUSIONS

In the preceding four examples, we have examined instances of materials developed with specific properties or combinations of properties to meet the requirements of advanced missile and spacecraft requirements. Not only have requirements on properties steadily become more stringent but also the compression in development time has become more evident. As shown in Fig. 15 (Ref. 10), S. Pellini of the U. S. Naval Research Laboratory has expressed this convergence of system complexity (increasing) and development time (decreasing) very succinctly:

"In the old days of evolutionary growth in functional capabilities, we could rely on the input from the day-to-day problems of hardware development to sense the direction of R&D required to attain the next incremental step in functional capability. In effect, research mana-

Table 4  
 SUMMARY OF MECHANICAL\* AND PHYSICAL PROPERTIES OF 20% VCL  
 SILVER-TUNGSTEN (Ref. 9)

Temperature (°F)	0.2% Offset Yield Strength (10 <sup>3</sup> psi)	Ultimate Tensile Strength (10 <sup>3</sup> psi)	Modulus Of Elasticity (10 <sup>6</sup> psi)	Elongation in 1.25 in. (%)	Reduction in Area (%)	Ultimate Shear Strength (10 <sup>3</sup> psi)	Thermal Expansion ΔL, in./in.	Thermal Conductivity (Btu/hr/ft <sup>2</sup> /°F/in.)
75	--	74.0	39.1	0	0	42.7	--	--
500	--	67.2	36.4	0	0	38.6	1.1	1000
1000	44.7	48.0	38.0	9.2	11.2	20.3	2.7	900
1500	--	45.7	36.0	2.9	2.1	22.5	3.6	750
2000	23.6	35.2	38.5	4.6	0.0	17.9	4.7	640
2500	15.2	19.6	14.1	7.0	17.5	11.7	6.0	500
3000	10.4	11.7	10.0	7.3	18.5	6.8	7.6	300
3500	7.0	6.4	6.3	4.7	10.7	4.1	9.1	400
4000	5.5	6.2	5.6	2.9	10.7	2.2	10.3	410

\*Mechanical properties determined at a strain rate of 0.05 in./in./min

gement could proceed by adaptation, i. e., by sensing future direction from current experience. Today, we must project to jump increases in functional capabilities that can be attained only by jumps in capabilities of materials to perform more efficiently or to endure more severe environmental conditions. Actually, the analytical problem is complicated by a variety of possible jumps, each with a specific related jump in materials capabilities..."

It must be the job of the materials researcher to perform the necessary analysis of requirements and to effect the necessary synthesis of materials to make these jumps not only possible but to a high probability of success, predictable.

Future progress in the aerospace field is critically dependent on the solution of these crucial materials problems as they arise. Materials requirements for lunar space missions may reasonably be expected to be more severe than for satellite applications; Venus and Mars probes will put yet more rigorous demands on our ingenuity in supplying materials.

Traditionally, the point of view of the user of materials was to fit the design or product to the properties of a material. This attitude has changed. The major concern now is finding and applying a material or materials with the right combination of properties to meet the design and service conditions. This attitude is end-service oriented, and leads obviously and inevitably, to the tailor-making of materials.

## REFERENCES

1. W. R. Micks, "Selection of Materials in Minimum Weight Design", paper presented at the Design Engineering Conference of the American Society of Mechanical Engineers, New York, May 20-23, 1963, AD 401773
2. W. R. Micks, "Materials Engineering in the Systems Context", paper presented to 54th Annual Meeting, AIChE, New York, December 3-7, 1961
3. M. A. Steinberg, "The Role of Composites in Missile and Spacecraft Applications", paper presented at Fifth Plansee Seminar on Materials for the Space Age, Reutte, Tirol, Austria, June 22, 1964
4. M. A. Steinberg, "Materials Innovations and Optimization in Weapons Systems Development", paper presented at IAS 31st Annual Meeting, New York, January 21-23, 1963, IAS Paper No. 63-47
5. T. E. Tietz and R. A. Perkins, "Status of Refractory Metal Sheet Alloys: Availability, Properties, and Fabrication", Trans. AIAA-ASD Vehicle Design and Propulsion Meeting, Dayton, Ohio, November 4-6, 1963
6. R. A. Perkins, "Coating for Refractory Metals: Environmental and Reliability Problems", paper presented to 1964 Golden Gate Metals Conference, San Francisco, February 13-15, 1964.
7. R. A. Perkins, "Status of Coated Refractory Metals", First AIAA Annual Meeting, Washington, D. C., June 29-July 2, 1964, AIAA Preprint 64-357
8. R. W. Fenn, Jr., D. D. Crooks, and R. C. Pasternak, "New Ductile Beryllium-Aluminum Wrought Alloys", paper presented at 67th Annual Meeting of the American Society for Testing and Materials, June 21, 1964, Chicago
9. C. G. Goetzel and J. B. Rittenhouse, "The influence of Processing Conditions on Properties of Silver-Infiltrated Tungsten", paper presented to International Powder Metallurgy Symposium, Paris, June 15-17, 1964
10. W. S. Pellini, "The Management Problem of Organizational Interfaces in Materials R&D Laboratories", paper presented to Seminar on Management of Materials Research, American Institute of Mining and Metallurgical Engineers, Harriman, N. Y., May 27-29, 1962

ACKNOWLEDGEMENTS

The author wishes to acknowledge the assistance of Dr. John B. Singletary, Mr. John Rittenhouse, and other members of the Materials Sciences Laboratory in the preparation of this paper.

Gratefully acknowledged also are many private communications with Mr. William R. Micks of the Rand Corporation who provided information invaluable in the preparation of this paper.

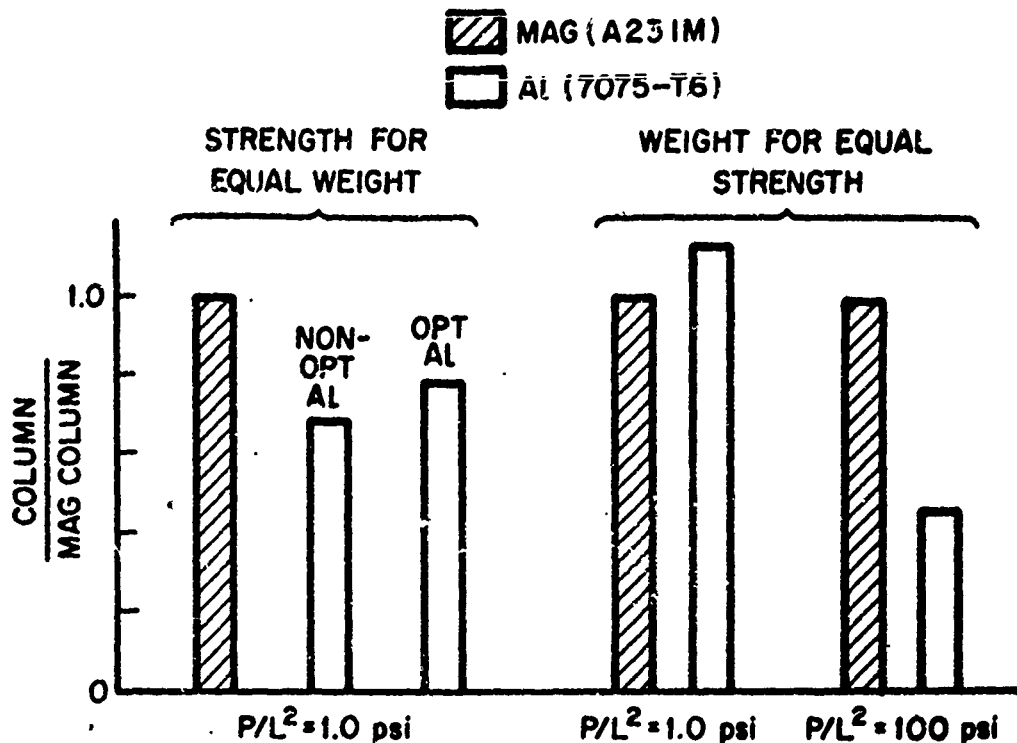

Fig. 1 Comparison of Relative Efficiency of Magnesium and Aluminum in Columns (Ref. 1)

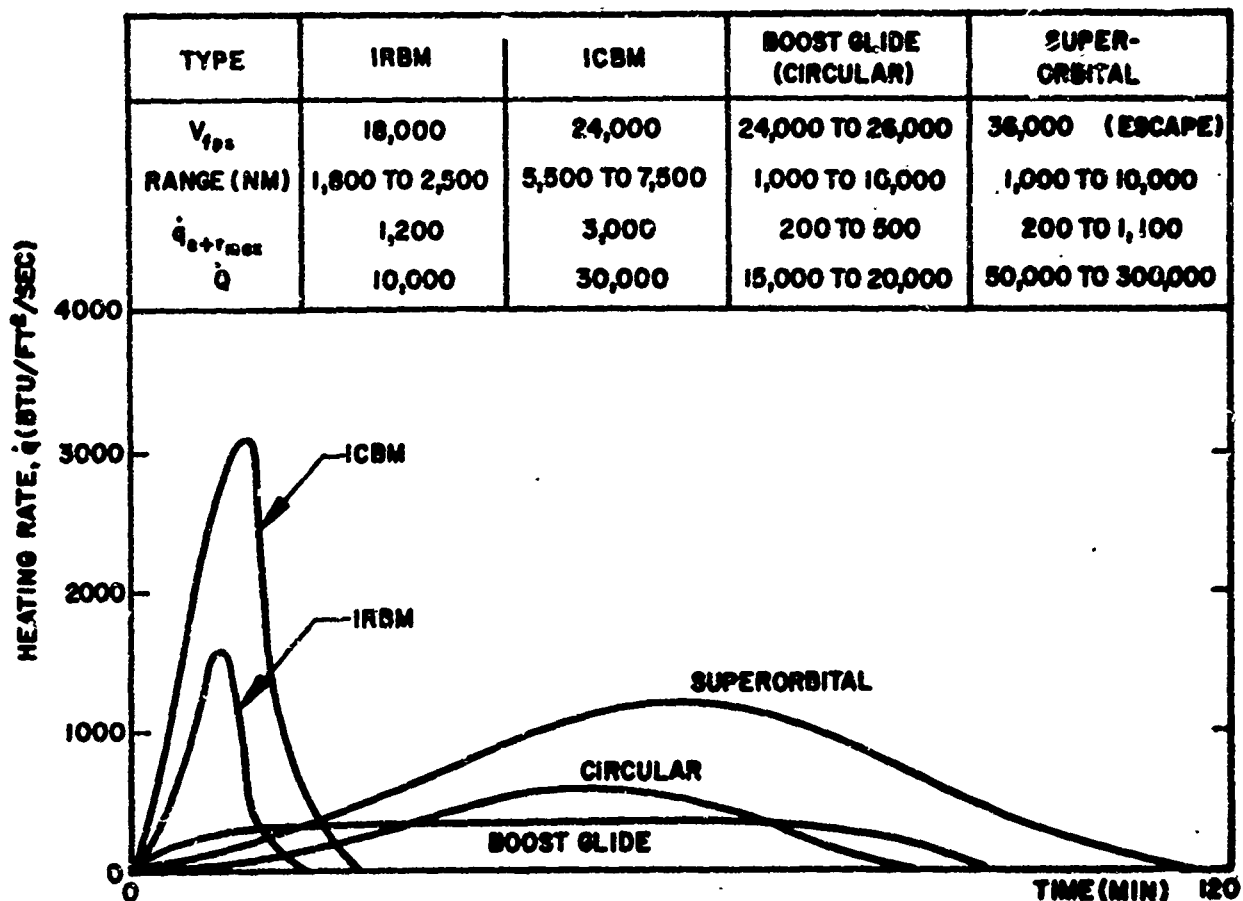

Figure 2 Comparison of Typical Reentry Parameters (Ref. 3)



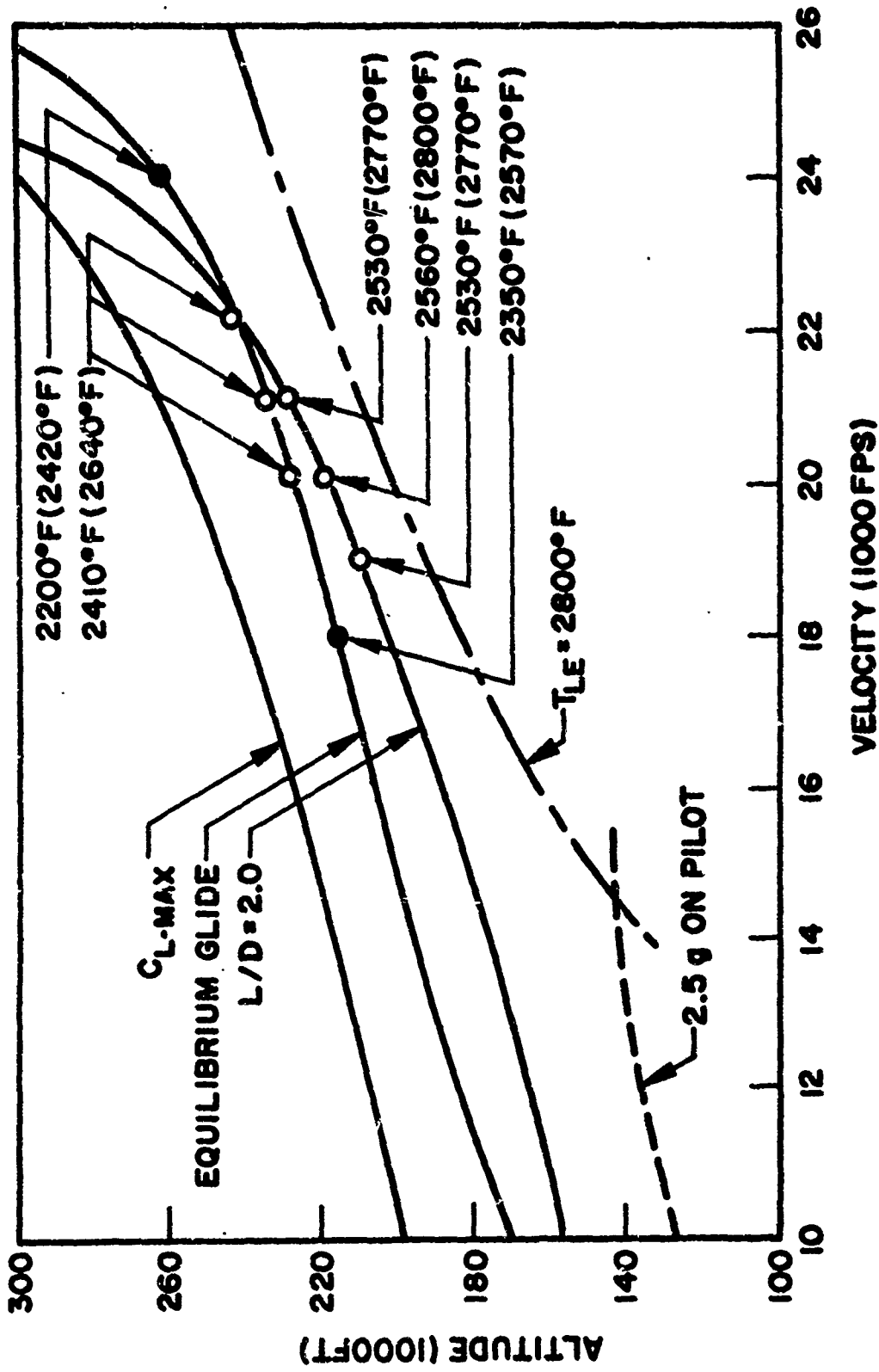

Fig. 3 Typical Flight Corridor of a Winged Reentry Vehicle  $W/C_{DA} = 200 \text{ lb/ft}^2$  (Ref. 4)

# H<sub>2</sub>O<sub>2</sub> BURNER FACILITY

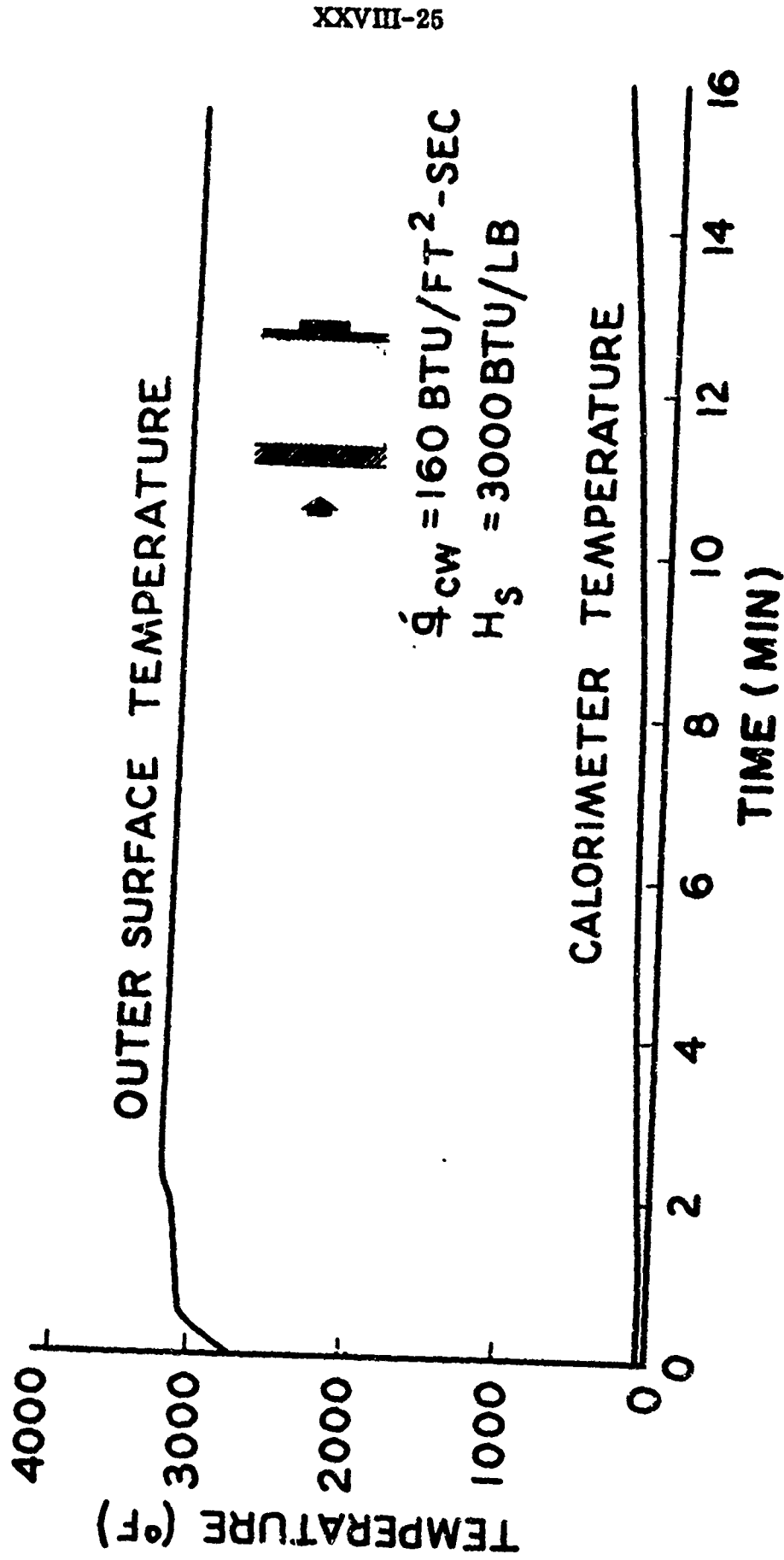

Fig. 4 Temperature Response of Lock-Heat Composite

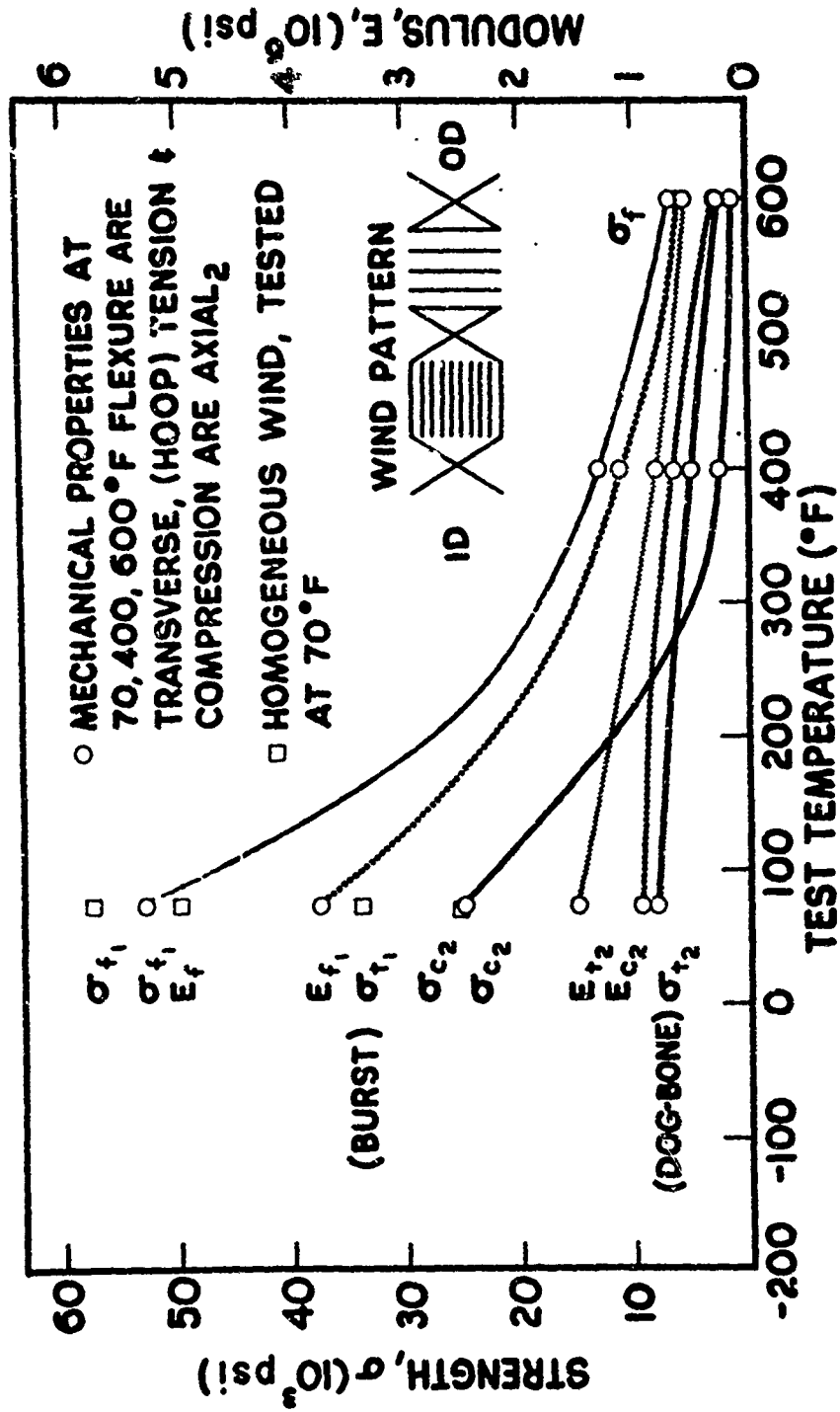

Fig. 5 Mechanical Properties of Lock-Heat

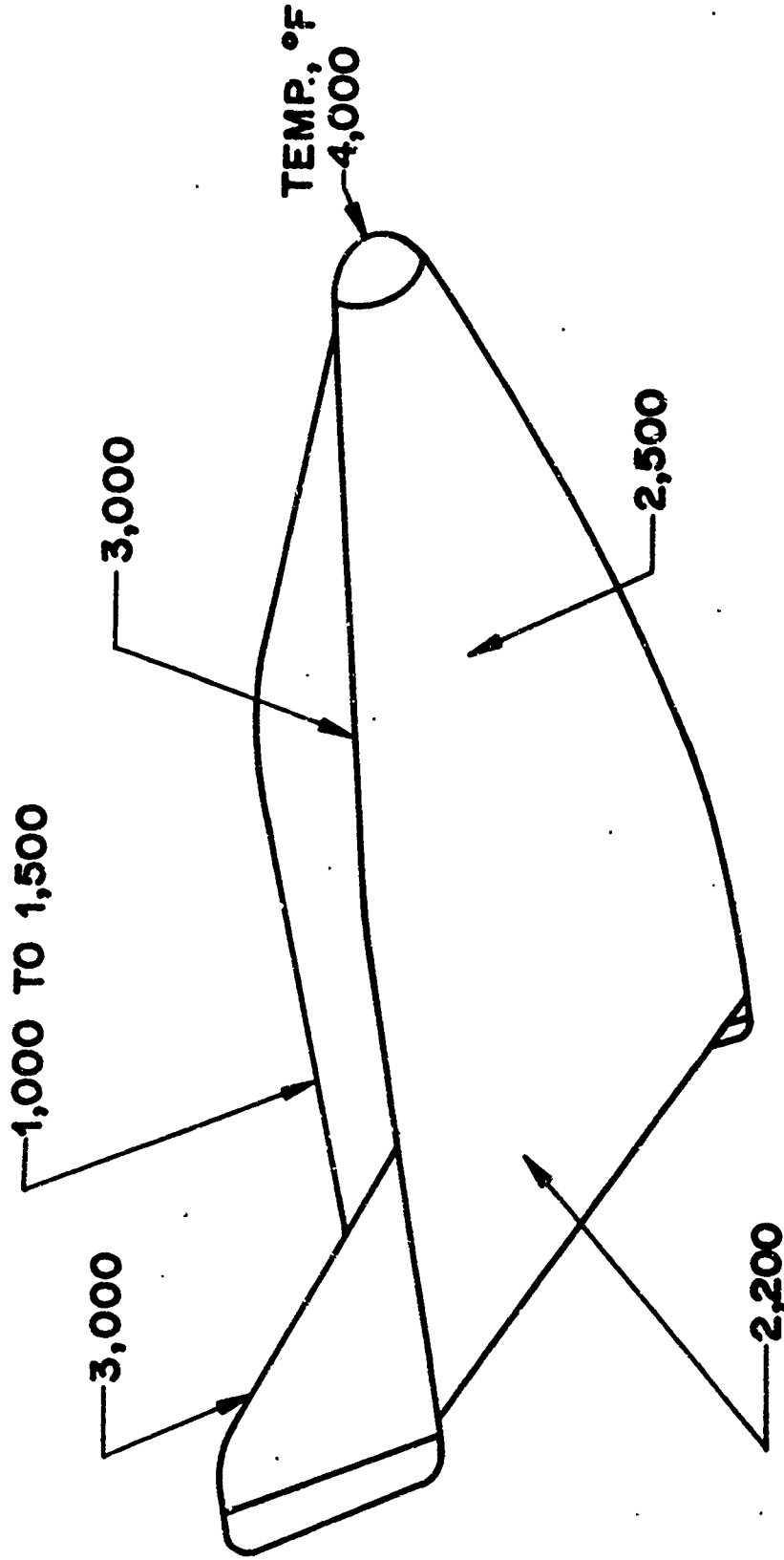

Fig. 6 Surface Radiation Equilibrium Temperatures for a Reentry Glider (Ref. 4)

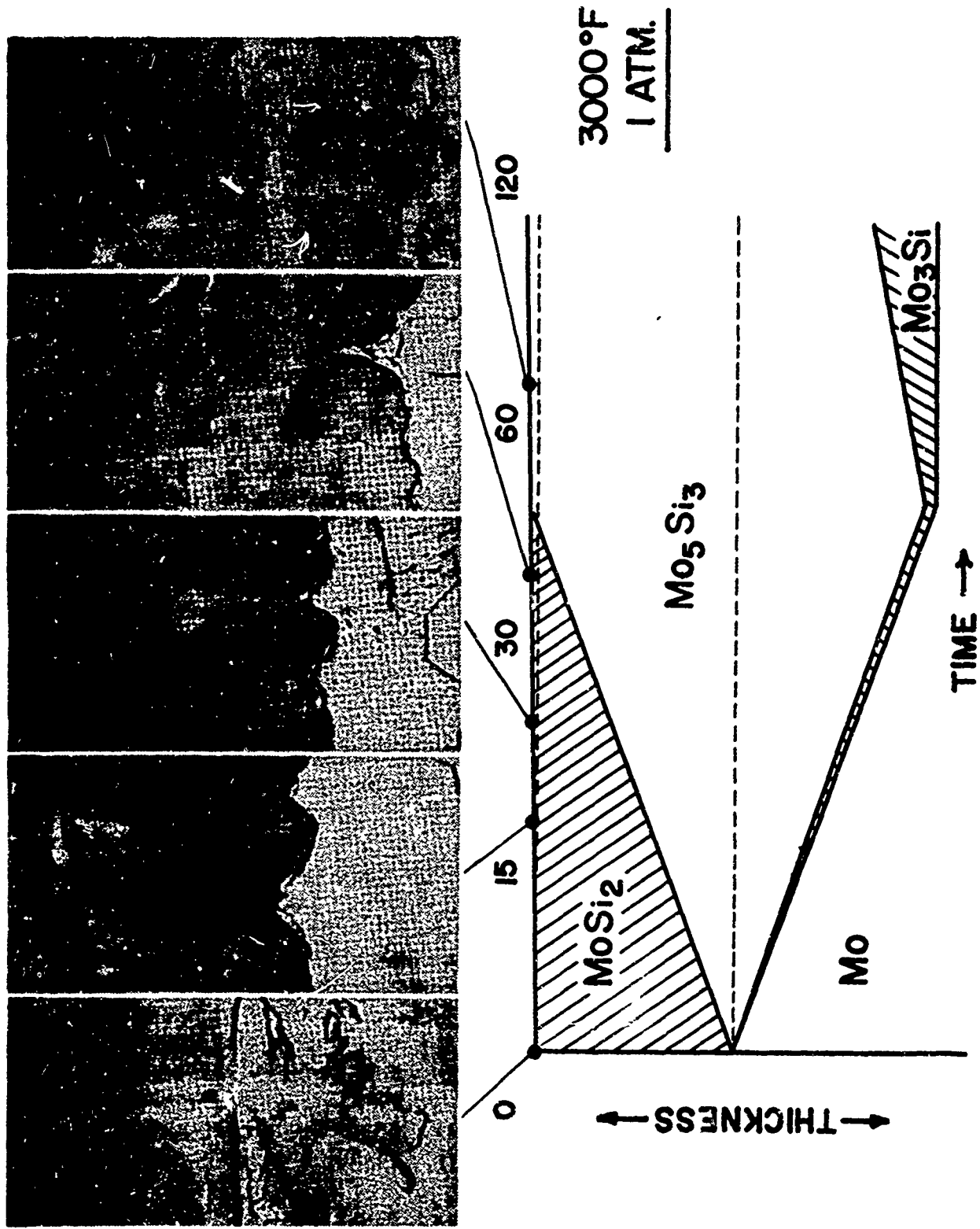
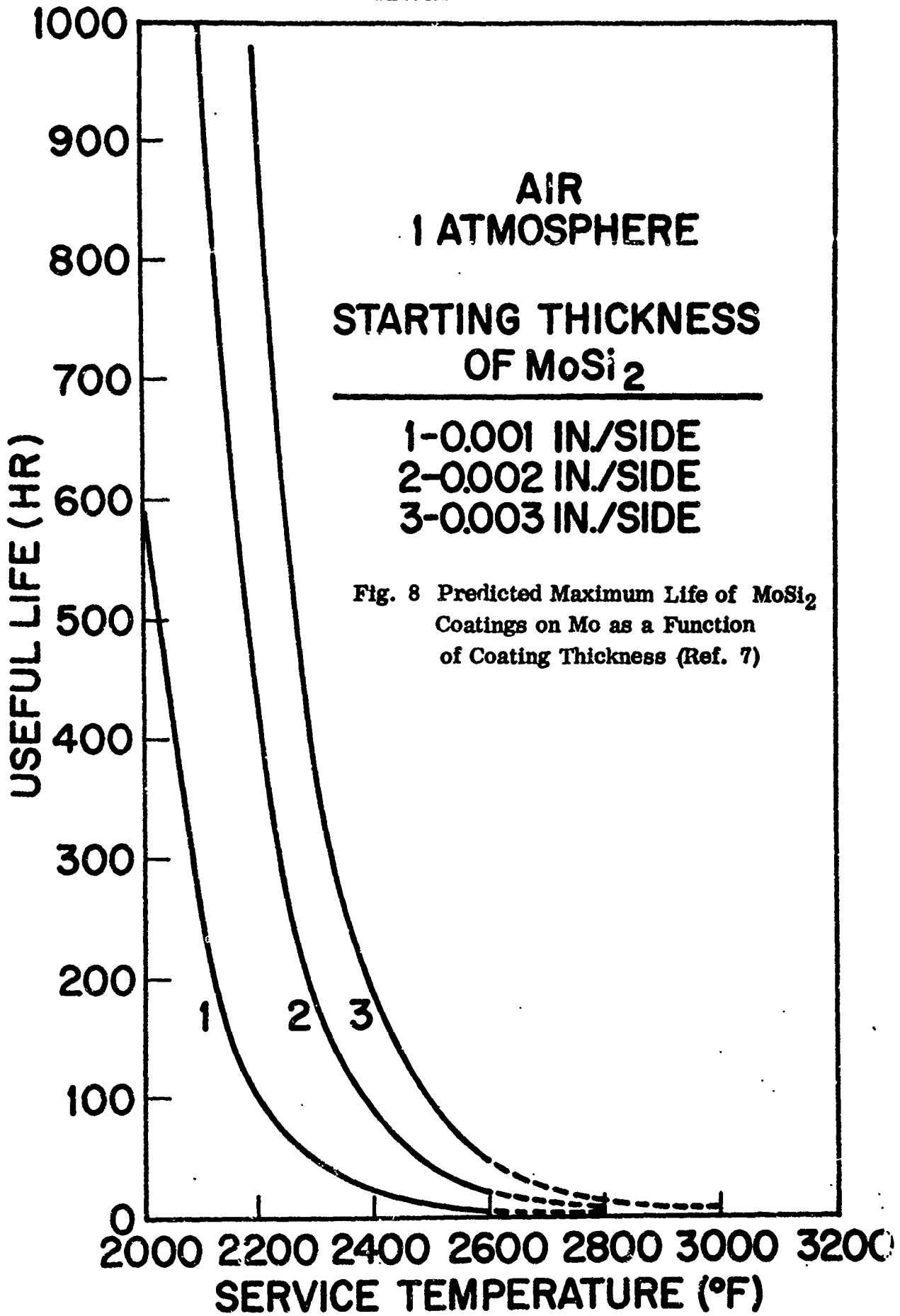

Fig. 7 Structural Changes Resulting From Diffusion of Silicon Into the Substrate (Ref. 6)



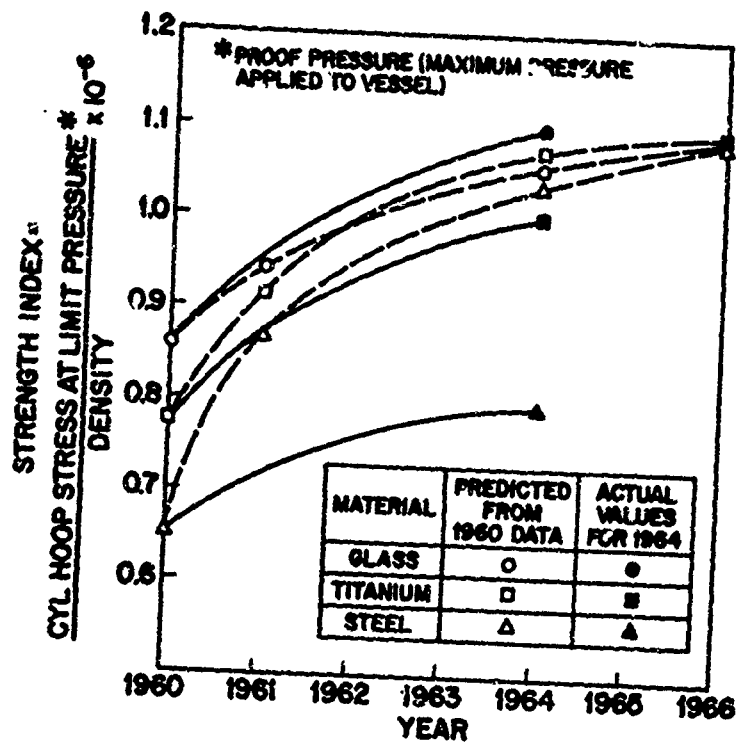

Fig. 9 Strength Index Values for Three Structural Materials (Ref. 3)

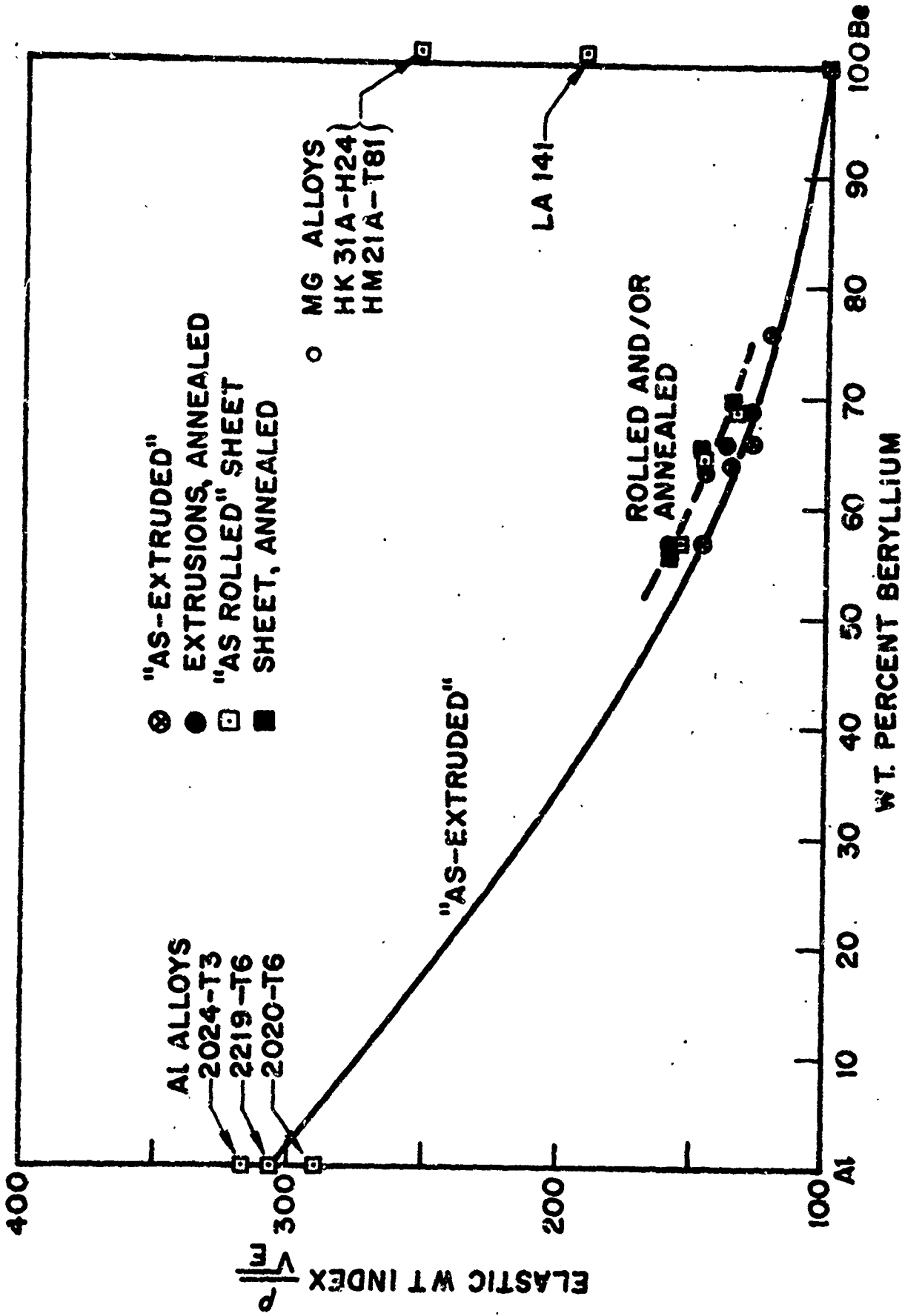

Fig. 10 Elastic Weight Index of Beryllium-Aluminum Alloys as Compared to Competitive Structural Materials: Beryllium; LA141, HM21A-T81 and HK31A-H24 Magnesium Alloys; and 2024-T3 2219-T6 and 2020-T6 Aluminum Alloys (Ref. 8)



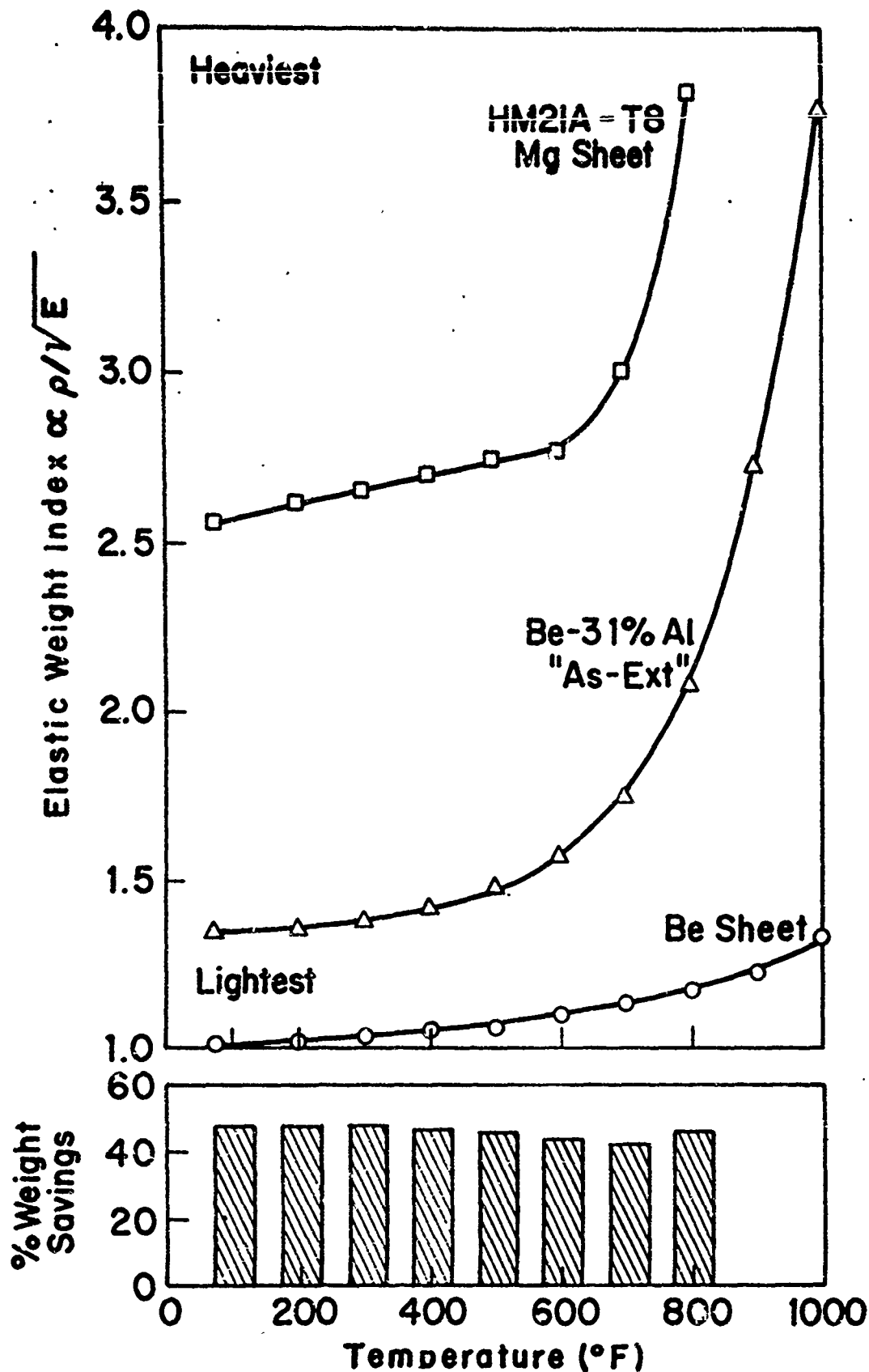

Fig. 11 (a) Elastic Weight Index of "As-Extruded" Be-31.4% Al Alloy Compared to Beryllium and HM21A-T8 Magnesium Sheet as a Function of Temperature; (b) Weight Saved by Substituting Be-31.4% Alloy for HM21A-T8 Magnesium Alloy as a Function of Temperature (Ref. 4)

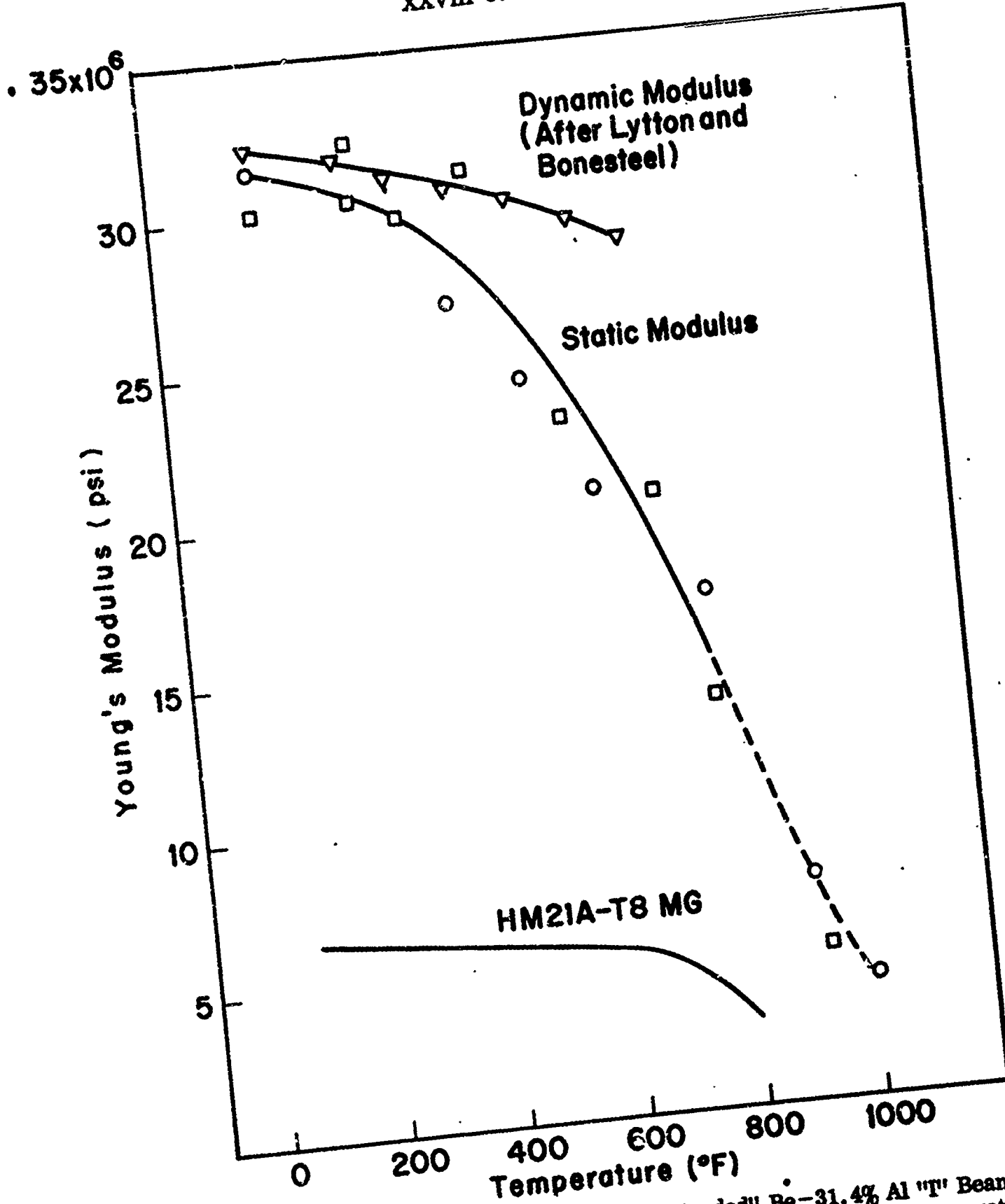

Fig. 12 Static and Dynamic Modulus of "As-Extruded" Be-31.4% Al "I" Beam Compared to HM21A-T8 Magnesium Alloy as a Function of Temperature (Longitudinal Direction) (Ref. 4)

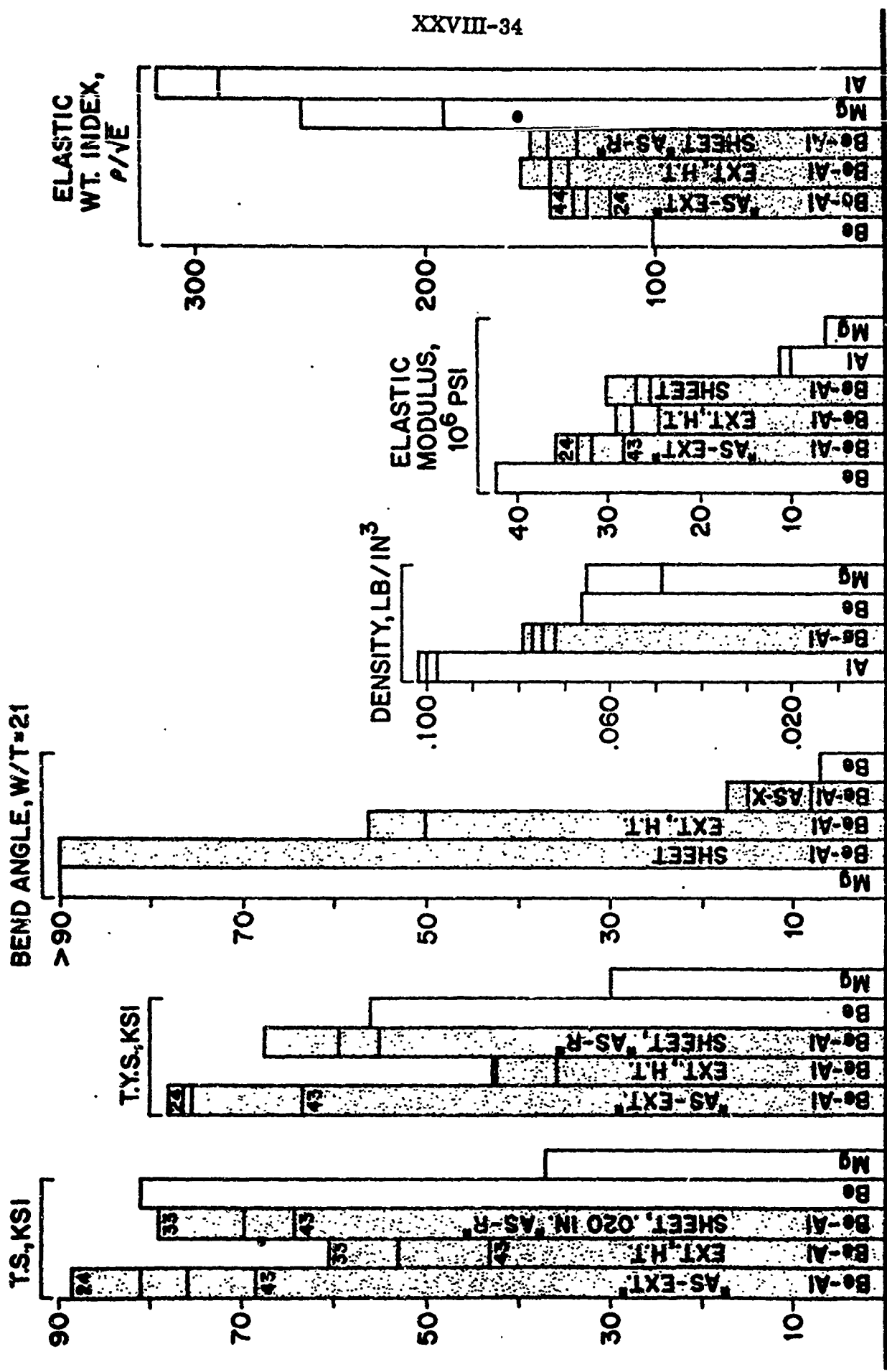

Fig. 13 Beryllium-Aluminum vs. Beryllium, Magnesium, and Aluminum at 75° F (Ref. 8)

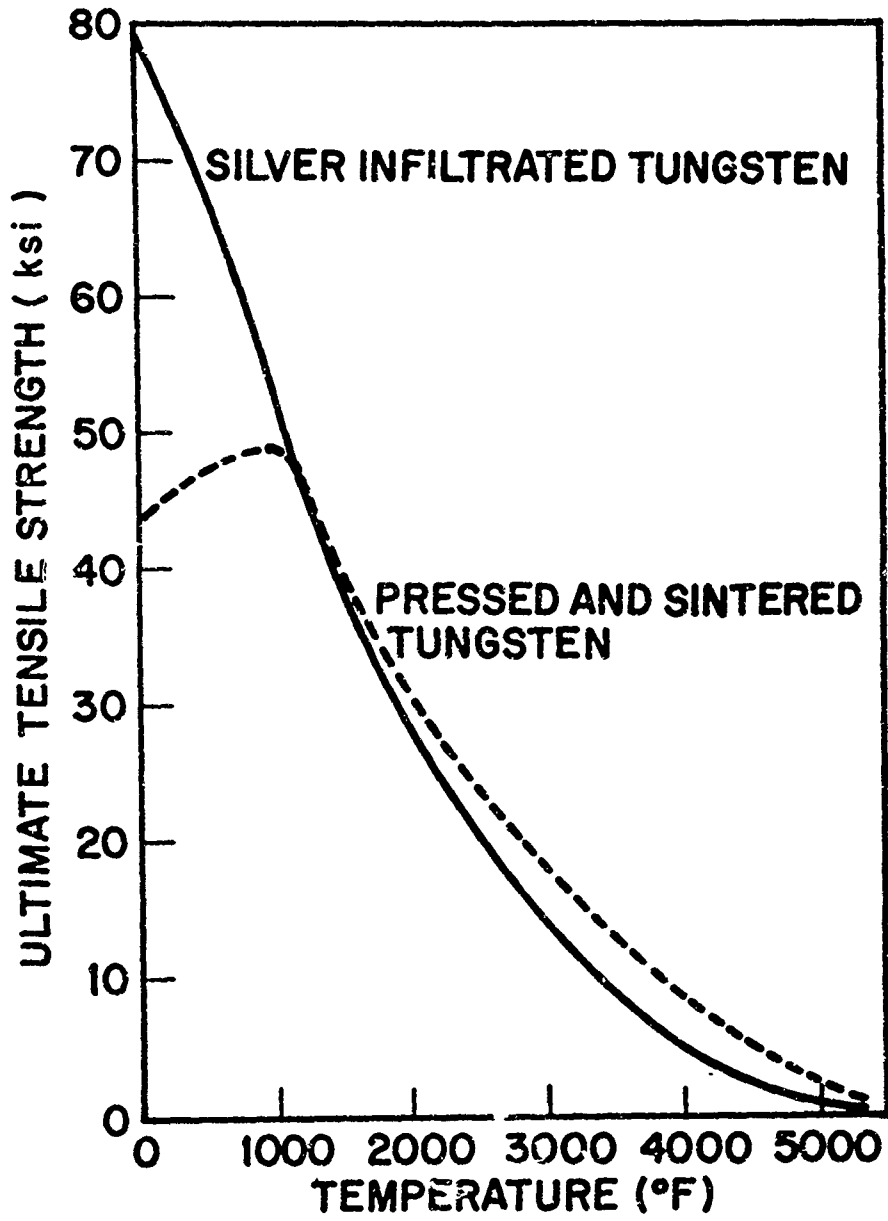

Fig. 14 Tensile Strength vs Temperature of Uninfiltrated and Porous Tungsten Body (Ref. 9)

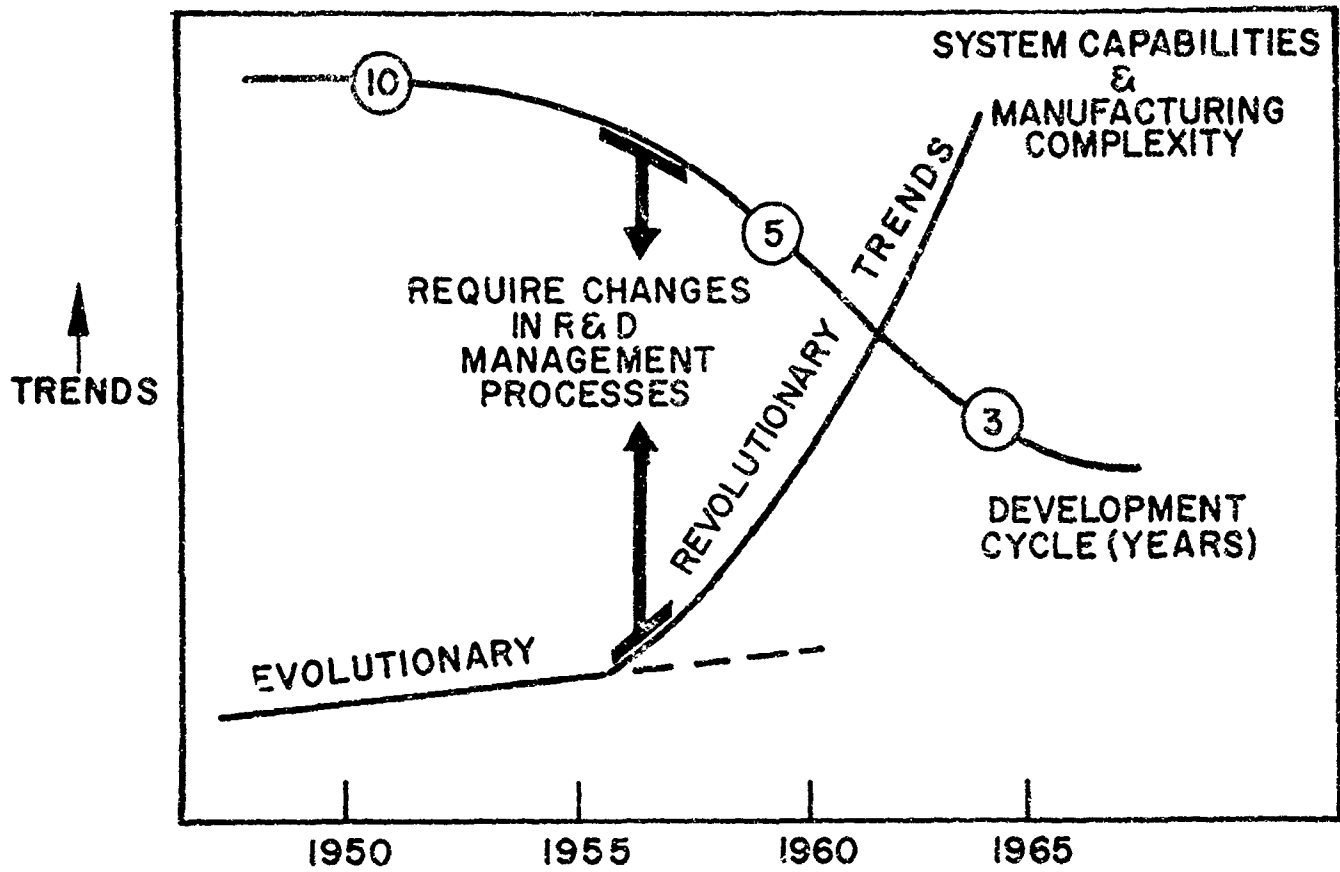

Fig. 15 Influence of System Factors on R & D Management Processes  
(Ref. 10)

## EXPLOSIVE WORKING OF METALS

by John S. Rinehart

## Introduction

Many metals are now being worked using the forces generated by explosive charges, and within the past ten years, a whole new technology has developed in this area which has been adopted throughout the world by several hundred manufacturers. By now, the techniques for explosively working metals, compacting metal powders, work hardening, drawing, forming, swedging, welding, and cutting metals are well understood and established.

Utilization of explosives to do work is not new. Explosives have been used constructively for many centuries by mining and civil engineers and farmers for blasting rock and earth and for removing obstructions, and they have been used for destructive purposes in military operations. It is, therefore, somewhat surprising that metal workers delayed so long in adopting explosives as an effective tool. Perhaps the main reason for this is that a knowledge of explosives is not one of the normal accoutrements of the average engineer; in fact, most engineers consider explosives to be dangerous and uncontrollable materials, which, upon detonation, produce exceedingly unpredictable effects. Quite the contrary is the case. Explosives are only dangerous when misused. Their proper application is not hazardous, and their effects are just as predictable as other types of force generators commonly used in metal working operations.

## EXPLOSIVES

Explosives fall into two categories: low explosives or propellants, and high explosives. Chemically the two types of explosives are not substantially different. They both contain chemical compounds rich in carbon, hydrogen, nitrogen, and oxygen, which react exothermically to produce large quantities of hot gases, carbon dioxide, carbon monoxide, nitrogen, and water vapor, that, on expansion, can work metals. The compositions of several explosives are listed in Table 1.

The heat of reaction ranges from about 700 cal/gm to 1200 cal/gm depending upon the explosive, and the amount of gas released is in the neighborhood of 1000 cc/gm when the gases have been expanded to normal temperature and pressure. Low explosives differ from high explosives in the rate at which the chemical reaction takes place. In low explosives, burning is relatively slow, only taking place at the surface of the material and moving inward at the rate of a few centimeters per second.

Furthermore, the rate of burning is strongly dependent upon ambient pressure; thus, confined propellant charges burn much more rapidly than when unconfined. The usual propellant charge takes several milliseconds to burn itself out.

High explosives, on the other hand, react extremely rapidly, detonation proceeding through the explosive at a rate of 6000 to 7000 km/sec, and the reaction is insensitive to ambient pressure. High explosive charges are consumed in a matter of microseconds.

The pressures generated by low explosives depend upon the extent to which the evolved gases are confined, pressures commonly ranging from 20 to 5 kilobars. High explosives generate pressures of 200 to 300 kilobars, the pressure being independent of the amount of explosive or confinement.

#### METAL-EXPLOSIVE SYSTEMS: LOW EXPLOSIVES

Many types of metal-explosive systems have been developed, some utilizing low explosives, and others high explosives. The low explosive system is usually a closed system in which the propellant is sealed within the workpiece, which, in turn, is surrounded by the die. The part to be formed expands and assumes the desired shape as a consequence of the steady, relatively slowly developing internal pressure resulting from the burning of the propellant. In practice, for ease of operation, the systems shown in Figs. 1 and 2 are quite common, the charge being contained in a shot-gun-like cartridge, which is easily ignited externally. In the bulging operation of Fig. 1, the hot gases fill the work-piece, pushing it into its new shape which is determined by the shape of the die. The situation in Fig. 2, a free forming operation, is different in that the final pressure is preselected so that the workpiece assumes the desired shape without the use of a constraining die.

A modification of the same sort of system is the operation illustrated in Fig. 3. In this case, the propellant gases actuate a piston which, in turn, pushes against hydraulic fluid contained within the tubular blank to be formed, the fluid bulging the blank to the shape of the closed die.

A spark-igniter guide, having two bulges, and formed from Type 310

stainless steel tubing, is shown in Fig. 4 along with a blank of the type from which it was formed. The blank was 5/8 inch O. D., 2 7/8 inches long, with a .01 inch thick wall, and was formed in a closed system using smokeless powder in the manner illustrated in Fig. 1. This is simply one of the many parts that can be formed this way. The closed system utilizing propellants is especially suitable for forming thin walled tubes used in manufacture of aircraft parts. Also, many companies are successfully sizing tubing by this method.

Low explosives which are usually in the form of gun powder are easy to package, handle, and ignite. They are also relatively noise free. Consequently they are finding extensive usage in small parts industries. They have the disadvantage of being useful only in closed systems which are difficult to fabricate and maintain and especially so when the parts to be worked are large.

#### METAL-EXPLOSIVE SYSTEMS: HIGH EXPLOSIVES

High explosives are utilized in two ways: in one, called a stand-off operation, the explosive charge is placed some distance from the work-piece, usually with water separating them; in the second, called a contact operation, the explosive is placed in intimate contact with the work-piece, or may be separated slightly from it by an intervening layer of solid material.

#### STAND-OFF OPERATIONS

A typical stand-off operation utilizing a concentrated point charge is illustrated in Fig. 5. The charge is placed in water some distance above the work-piece, which in this case consists of a flat plate held down at the edges. The work-piece is above a die, and when it is struck by the shock wave generated by detonation of the explosive, it is pushed down to conform to the shape of the die. On detonation, the high pressure explosion products push against the water, creating an intense, transient pressure pulse, or shock wave, which moves down through the water with a velocity of about 2 km/sec. The actual part made from this operation, a small fuel filter for a jet engine, is shown in Fig. 6. This part was fabricated from 201 stainless steel, 0.005 inches thick and about 1/2 inches in diameter. The explosive was a detonator containing about 20 grains of explosive and was positioned 2 inches from the work-piece.

The duration and intensity of such a water shock depends upon two factors: the size of the explosive charge, and the distance from the charge, being related



specifically by the two equations;

$$P_m = A (W^{1/3}/R) D$$

and

$$I = B W^{1/3} (W^{1/3}/R) F$$

where A, B, D, and F are constants given in Table 2 for three different explosives; P is the peak pressure; I is the impulse; W is the weight of the charge; and R is the distance from the charge at which the pressure and impulse are measured.

Nomographs relating peak pressure to charge weight and distance, and impulse to charge weight and distance are reproduced in Figs. 7 and 8 for TNT. Nomographs for other explosives will not differ substantially from these. Note that peak pressure and impulse are much more sensitive to distance than to charge weight. The pressure time profiles of shock waves generated in water by a one pound charge TNT are illustrated in Fig. 9 for four distances from the charge. The maximum pressures are in the neighborhood of one kilobar and the duration of the waves of the order of 150 microseconds. In some stand-off operations, air instead of water separates explosive and work-piece.

Since the coupling or impedance match between the explosive and air is so much less than the coupling between the explosive and water, the pressures of the shock waves in air will be very much less, one-fourth to one-fifth, than those in water, as illustrated in Fig. 10.

High explosives come in many forms, ranging from liquid nitroglycerin, which would never be used in an explosive forming operation, to granulated powder, cast and pressed blocks, and more convenient forms such as dynamite, sheet explosive, and Primacord. By far the easiest of these to use are the sheet explosive, an E. I. duPont de Nemours product consisting of a PETN-rubber mixture, and the Primacord, a small-diameter column of PETN wrapped in a plastic sheath, both of which can be readily cut and shaped. Electrically triggered detonators are generally available to set off the explosive.

A cubical, short cylindrical, or spherical charge produces a spherically expanding shock wave. In many explosive forming operations, such a shock does not produce the distribution of pressure on the work-piece that is best suited to forming the part, so that it is common practice to use other charge configurations.

The ring charge used in a cupping operation (Fig. 11) is made either from sheet explosive or Primacord. Such extended explosive charges are used when large pieces are being formed and it is desired to distribute the explosive force more evenly over a wider area. The arrangement of Fig. 11 has been used successfully in forming from 3/16 inch thick mild steel the 8 ft diameter railroad tank car head shown in Fig. 12. The ring charge consisted of 4.4 pounds of duPont EL 506 plastic sheet explosive.

The forming of a corrugated cylinder is best accomplished by using a line charge extending the full length along the axis of the cylinder as illustrated in the setup of Fig. 13. Figure 14 shows, on the left, a 6 inch diameter work-piece of 0.010 inch thick A-286 stainless steel, and, on the right, the final corrugated cylinder formed by this method. Tolerances in this case were 0.002 inches on the diameter. The explosive was a length of duPont mild detonating fuse.

The three systems, (concentrated point charge, Fig. 5; ring charge, Fig. 11; and line charge, Fig. 12), are only representative of a very large number of others which are essentially modifications, combinations, and permutations of these three. The sizes of the systems and the shapes and sizes of the parts produced therein range widely. The cupping operation of Fig. 11 has been used to produce parts weighing only a few ounces through missile noses 5 or 6 ft in diameter and on up to dishing the ends of tank cars and other structures many feet in diameter. There is almost no limit, small or large, to the size of piece. For exceedingly large pieces, multiple charges are sometimes used, these being fired either simultaneously or in sequence.

Techniques for choice of die construction, charge configuration, and detailed design features of many specific processes have been worked out. In most cases in the past, this has been done empirically using trial and error methods. However, a number of productive, more fundamental studies, are now underway. The matters to be considered are hold-down rings, die material, and die placement. A typical assembly for drawing a blank is illustrated in Fig. 15.

Hold-down is accomplished by a pressure plate held in place by 3/4 inch bolts. The space below the work-piece is sealed with an O-ring so that it can be evacuated. Evacuation is common in most operations of this type. The presence of air is not desirable for, on compression, when the work-piece begins to move, the air, being heated adiabatically, may cause the work-piece to weld itself to the die. The vacuum need not be a good one, a pressure of a few centimeters being entirely adequate.

There are many satisfactory die materials. Kirksite, the die material of Fig. 15, has been widely used because of its ease of fabrication. But equally satisfactory dies have been made from concrete alone, concrete lined with laminated plastics, wood, plaster of Paris, and other easily shaped materials, as well as steel and aluminum. The choice of a die material is determined by the nature and size of the part to be produced, and the number of parts. The entire die is then usually placed in a large tank of water where the explosive will be located.

The size and construction of the tank varies from operation to operation, but its construction presents no unusual problems. A typical tank is shown in Fig. 16. This has a somewhat special feature in that air bubbles are used to ameliorate the shock from the explosive, preventing the shock wave from damaging the tank itself. Such an air cushion, while a common feature of many tanks, is not at all essential if the tank itself is strong and large enough.

## CONTACT OPERATIONS

Cutting, welding, and work hardening of metals, and the compaction of metal powders involve using explosive charges detonated in intimate contact with the materials being worked. Under such circumstances, the very high pressures, several million pounds per square inch, developed within the explosion products, act directly upon the metal, influencing it in a very different way than if a standard operation were used. On detonation, the explosion products push against the metal itself, setting up within it high intensity shock waves which traverse the metal at a rate of several thousand feet per second. The particle velocities associated with this shock are a few thousand feet per second, about 2,000 ft/sec in the case of an explosive detonated in contact with steel.

Consequently, during the transition of the shock, the material is highly compressed, to densities 30 to 40 percent above normal. Thus, the material, if a metal, may be substantially work hardened as a consequence of this compression. Manganese steel is especially amenable to work hardening in this way, and explosive hardening of manganese steel has been widely adopted in industry. The technique is to apply to the surface of the piece to be work hardened, commonly a railroad switch frog or the prongs of a steam shovel bucket, a layer of explosive in the form of duPont EL-506 sheet explosive, and then to detonate it. The increase of hardness achieved in this way is illustrated in Fig. 17.

If the material is a powder to be compacted, then the temporary density increase attained during transit of the shock wave is retained permanently as a result of the filling of voids in the material. A number of techniques have been adopted for accomplishing this compaction. Usually the full force of the explosion is too severe, breaking up the powder to be compacted, and must be attenuated. Water or steel or some other intermediary material is used to lessen the force of the explosion, as illustrated in Fig. 18. In this case, the powder to be compressed is placed within a steel tube which in turn is surrounded by a thin layer of explosive. On detonation, the explosive contracts the steel tube, which compresses against the powder, compacting it. Extremely high powder densities, greater than 99 percent, have been achieved in this way.

There are two types of cutting operations. In one, the full force of an explosive is used to shear the material in two, such as the cutting of an I-beam illustrated in Fig. 19. Such operations have been of great military import for many years, and consequently there exists a large amount of empirical data regarding the amount of explosive needed to accomplish various tasks. The second type of cutting operation is more subtle. The transient shock waves generated by the explosive charges are harnessed and directed to cut in a preselected manner. This has become more possible in recent years as the nature and interactions of such shock waves have become better understood. A typical example of the cutting action of such waves is illustrated in Fig. 20, which shows the way in which an explosive charge can be used to break up a square ingot into four large identical

pieces. Cutting results from the interference of reflected shock waves, tension waves arising from reflection at free surfaces of a compression wave.

There are a large number of situations like this in which stress waves can be used in a predictable manner to fracture cylinders, blocks, ingots, and like bodies. The guiding principle is that through the interference of transient stress waves, highly localized inhomogeneities in stress develop which break the material apart. Fracturing of this type is not always desirable, there being a number of cases in hardening or compacting materials using explosives where unwanted fracturing develops. Enough is now known about the dynamics of transient stresses and their various interactions so that usually such deleterious fracturing can be eliminated.

Welding or cladding of one metal by another has been one of the most successful of the contact explosive working operations. The two basic systems for accomplishing welding and cladding are illustrated in Figs. 21 and 22. In the system of Fig. 21, both plates are projected by explosive charges detonated simultaneously. In the operation of Fig. 22, the heavy plate to be cladded is placed on a firm foundation with the thin cladding plate projected against the parent plate by a single explosive charge. The stratagem is to project one plate against another at high velocity in such a way that a firm bond develops between the two. The critical parameter in the system is the angle  $\beta$ , the angle between the two plates.

## CONCLUSIONS

Although it cannot be expected to replace most conventional metal working operations, explosive working of metals has now become firmly established in many metal processing plants. The processes where it has been most effectively and widely adopted fall into two categories: those in which the process can only be done by utilizing the exotic and extreme conditions generated by explosives, such as work hardening of manganese steel, compaction of metal powders, or the production of re-entrant contours; and second, those in which the working of the metal could be accomplished by other means but only at excessive expenditure of time, effort, and money. The sizing of missile noses, or the production of a railroad tank car fall into the second category. These operations could be performed by conventional methods, but construction and procurement of dies and presses required to produce these latter parts are only economically feasible when a large number of production parts are anticipated. Explosive forming of a few parts on the other hand is relatively inexpensive and simple since the dies and tanks required are relatively easy to fabricate.

While explosive working is playing an extremely significant role in the highly technologically developed countries such as the United States, it seems destined to

play an even more important role in less technologically advanced societies where progress is being hampered by the lack of expensive capital equipment. Since explosive forming, in most instances, requires relatively little capital outlay, the techniques are ideally suited to making up for this lack. There appears to be no reason why a country such as Argentina should not avail itself of these new explosive working methods and techniques to solve some of the metal working problems which it is now facing.

Table 1. Chemical Compositions of Several Explosives

Name	Formula
Nitroglycerin (NG)	$C_3H_5N_3O_9$
Nitrocellulose (NC)	$(C_6H_7H_3O_{11})_n$
Trinitrotulene (TNT)	$C_7H_5N_3O_6$
Pentaerythritol tetranitrate (PETN)	$C_5H_8N_{12}O_4$
Cyclotrimethylene trinitramine (CTMTN of RDX)	$C_3H_6N_6O_6$
Trinitrophenylmethylnitramine (Tetryl)	$C_7H_5O_8N_5$
Picric acid	$C_6H_3N_3O_7$
Lead trinitroresorcinate (lead styphnate)	$C_6H_3N_3O_9Pb$
Lead azide	$PbN_6$
Mercury fulminate	$C_2N_2O_2Hg$

Table 2. Parameters of Shock Wave Similarity Curves for Several Explosives

Explosive	Density $10^{-4}A$	Peak Pressure $P_m$		Impulse $I(t)$		Energy Density $E(t)$		Time of Integration
		D	B	F	$10^{-3}C$	G		
TNT	1.52	2.16	1.13	1.46	0.89	2.41	2.05	6.7 0
Loose tetryl	0.93	2.14	1.15	1.73	0.98	3.00	2.10	5.0 0
Pentolite	1.60	2.25	1.13	2.18	1.05	3.27	2.12	6.7 0

(W in lb, R in ft, E = in-lb/in<sup>2</sup>,  $P_m$  in psi, I in lb- sec/in<sup>2</sup>)

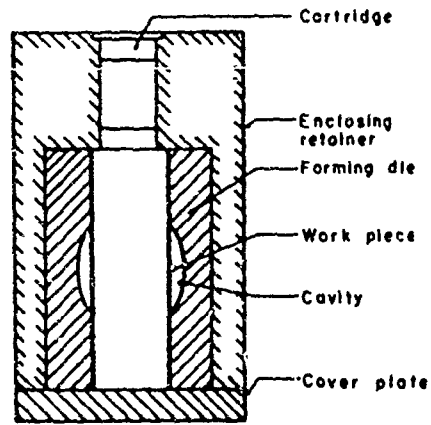

Figure 1 Bulging with a Powder Cartridge

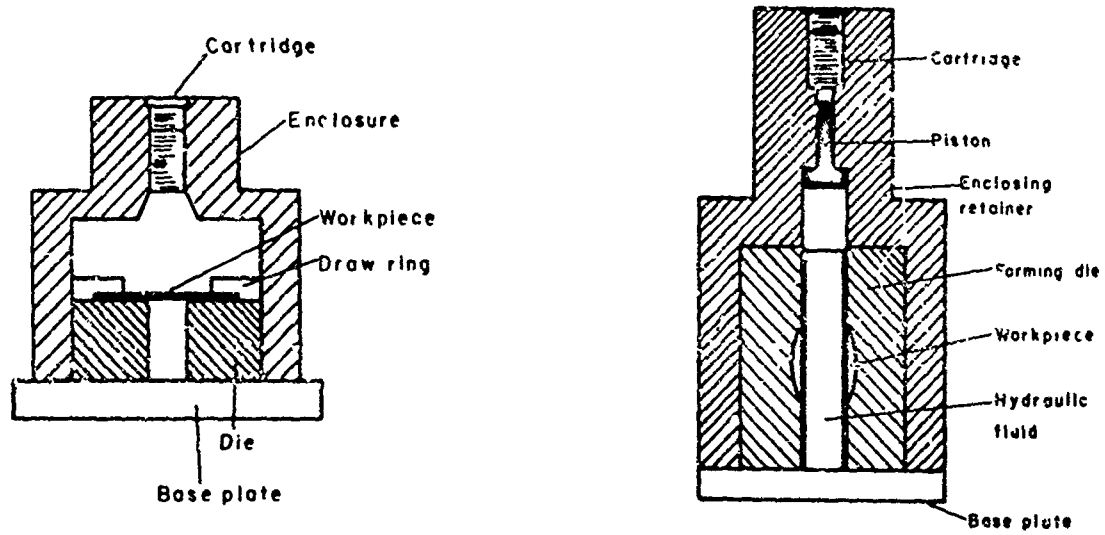

Figure 2 Free forming with a Powder Cartridge

Figure 3 Bulging Operation with a Cartridge-Hydraulic System



Figure 4 Spark Igniter Guide and Preform (Courtesy Olin Mathieson Chemical Corp.)

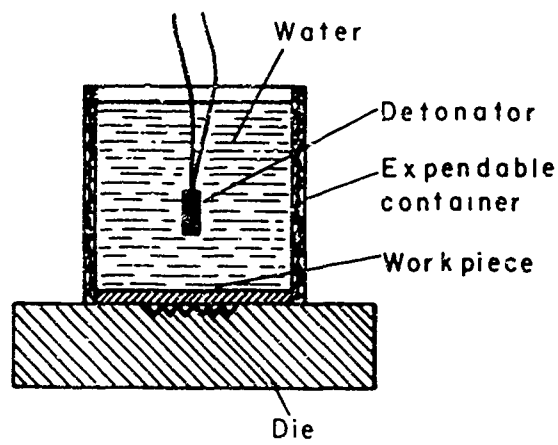

Figure 5 Method for Forming Flat Part with Detonator



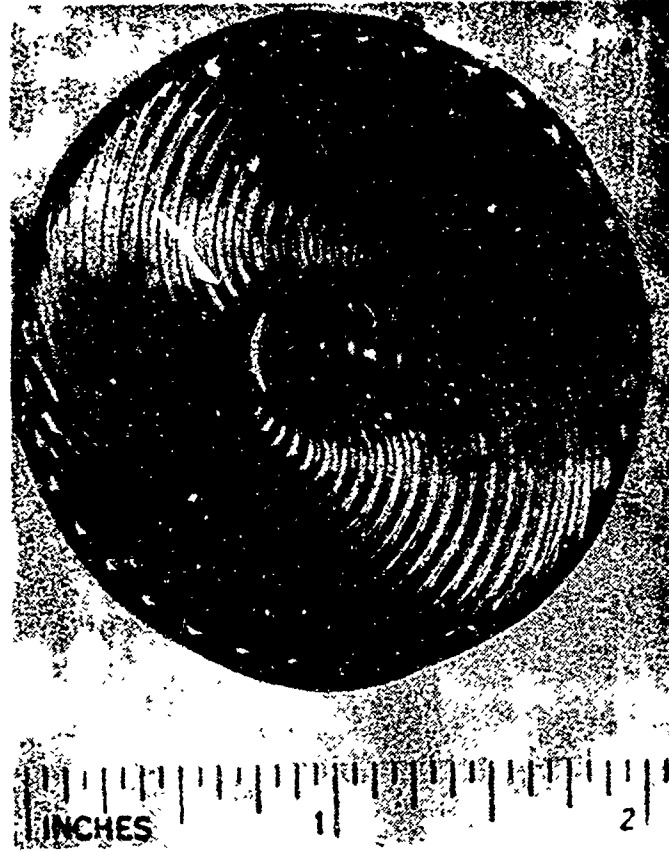

Figure 6 Jet Engine Fuel Filter

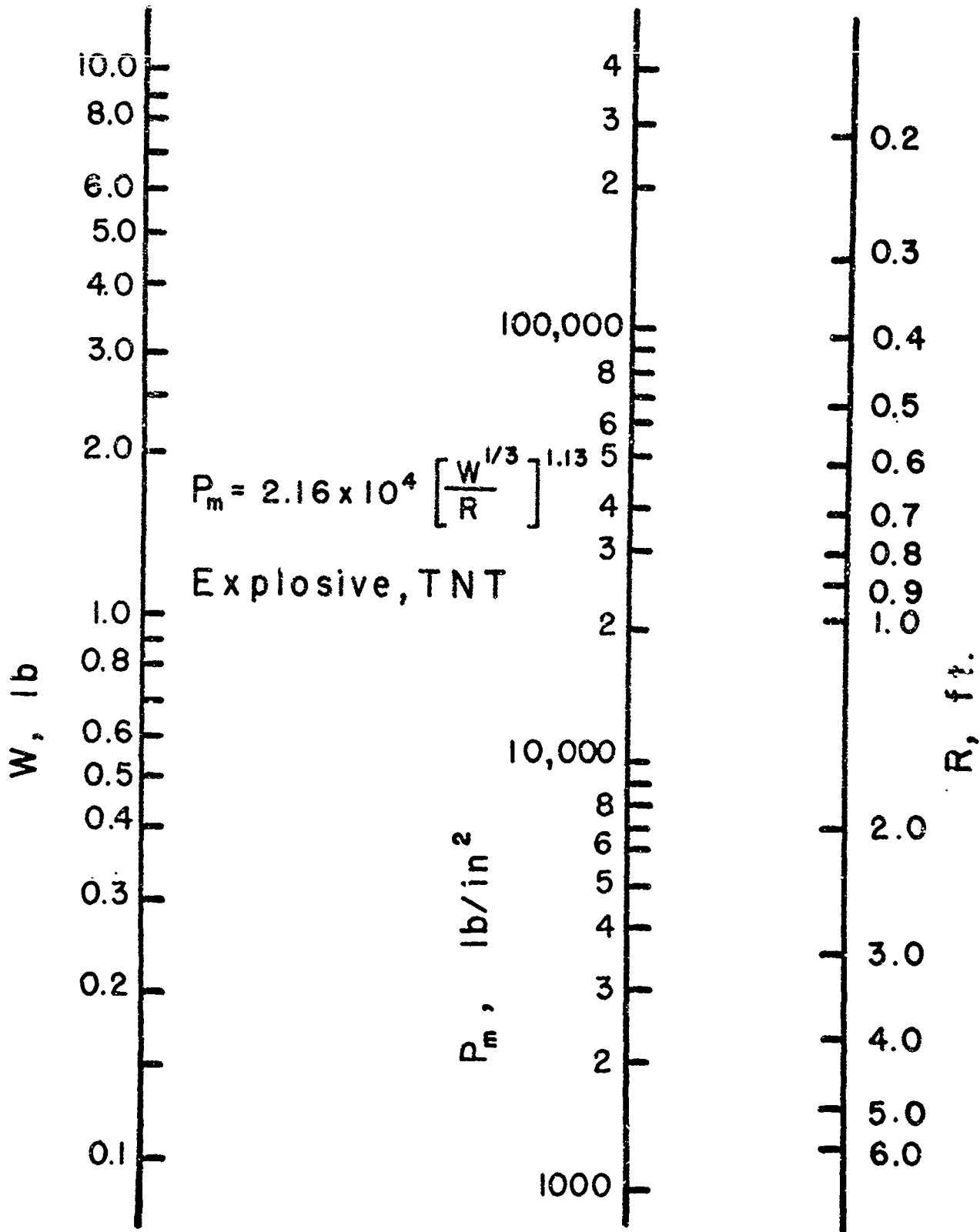

Figure 7 Nomograph for Computation of Pressures

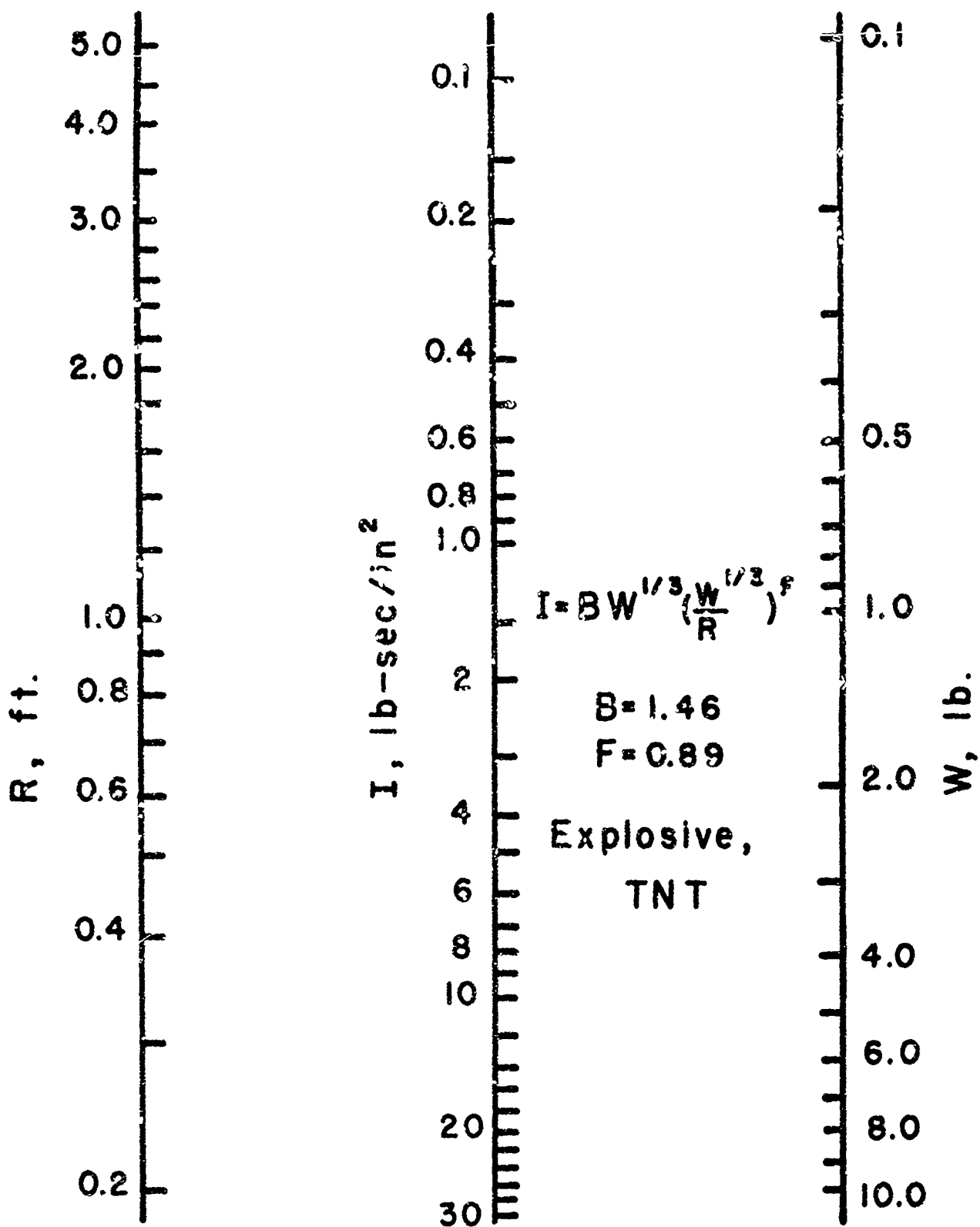

Figure 8 Nomograph for Computation of Impulses

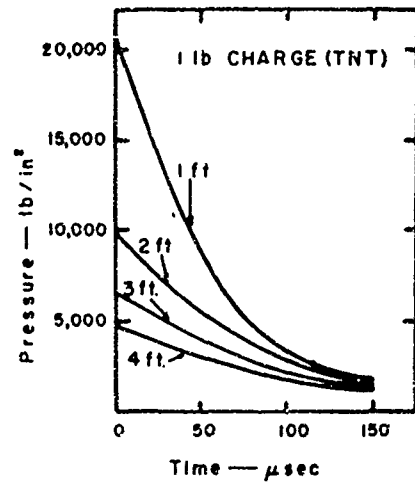

Figure 9 Pressure-Time Profiles of Shock Waves Explosively Generated in Water

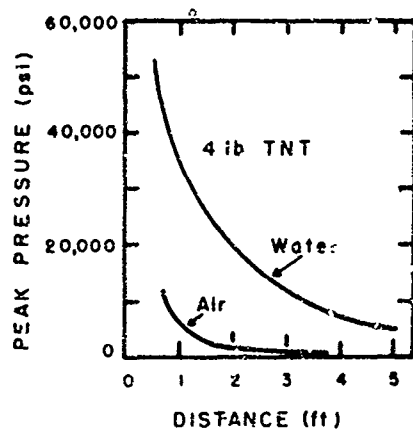

Figure 10 Comparison of Pressures in Shock Waves Generated in Air and Water by Detonation of an Explosive Charge

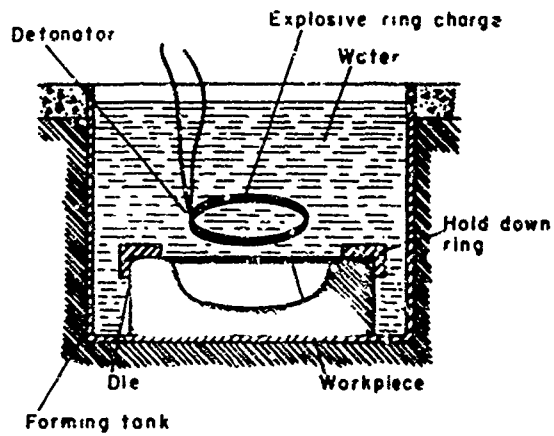

Figure 11 Method for Forming With a Ring-Shaped Charge

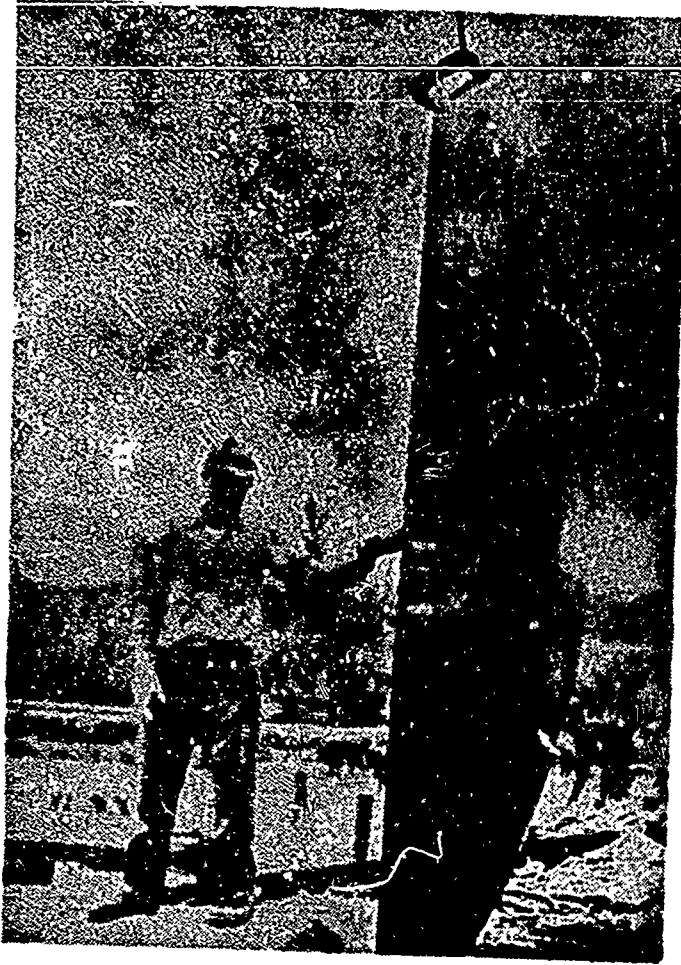

Figure 12 Tank Car Head (Courtesy E. I. duPont de Nemours, Inc.)

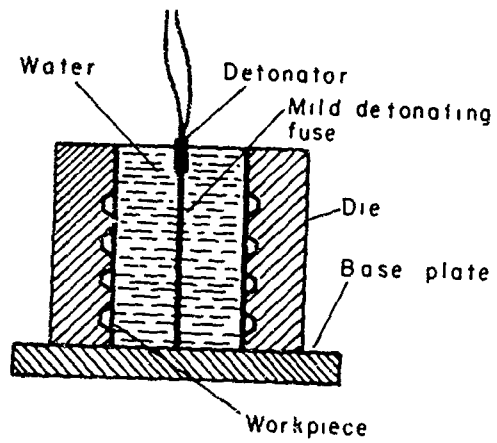

Figure 13 Method for Forming Corrugated Cylinder

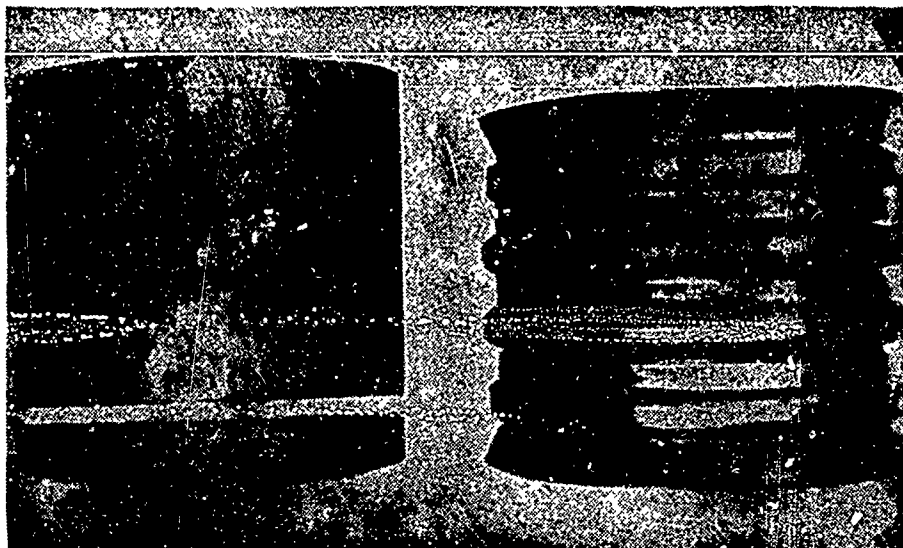

Figure 14 Formed Corrugated Cylinder (Courtesy E.I. duPont de Nemours, Inc.)

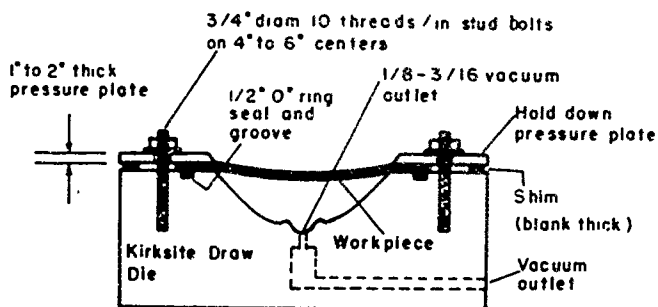

Figure 15 Typical Arrangement for Drawing a Blank

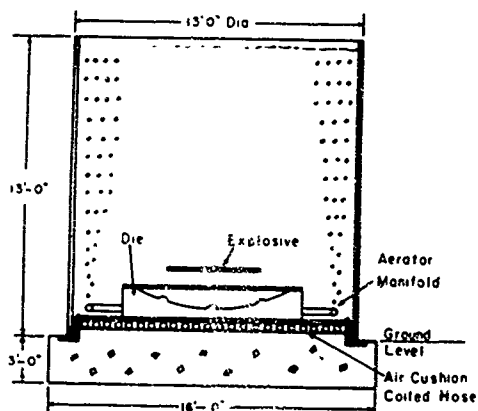

Figure 16 Forming Tank

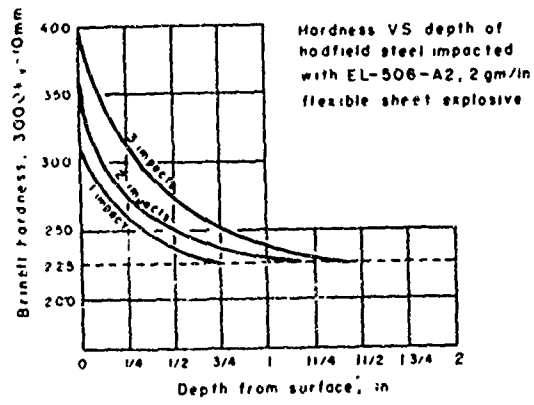

Figure 17 Hardness-Depth Curves for Explosively Hardening Manganese Steel

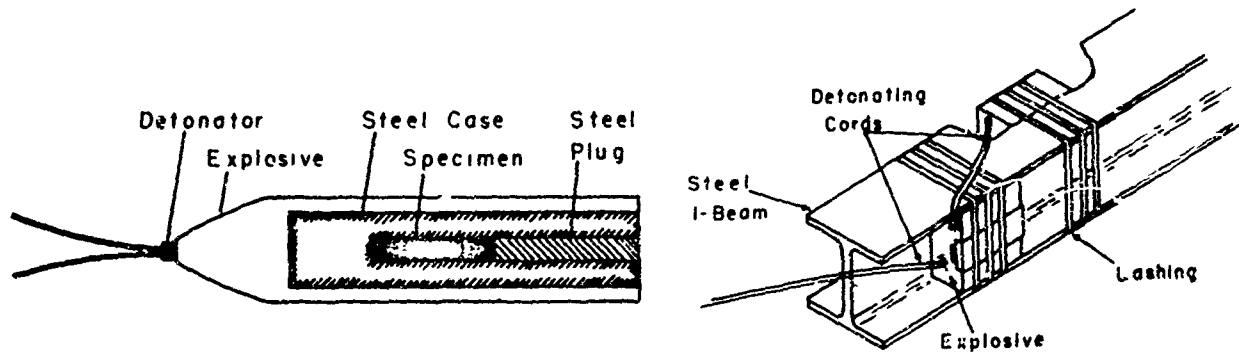

Figure 18 Collapsing Cylinder Type Explosive Press

Figure 19 Shearing an I-beam With Contact Charges

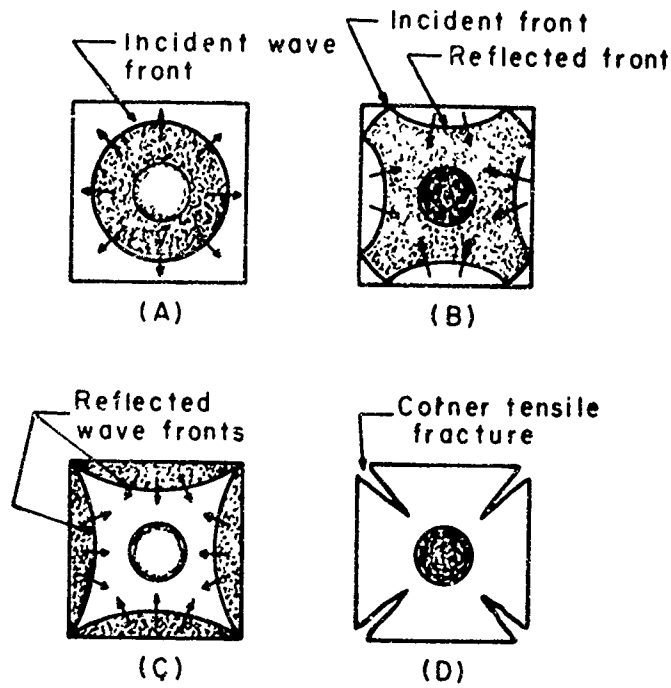

Figure 20 Cutting with Explosives

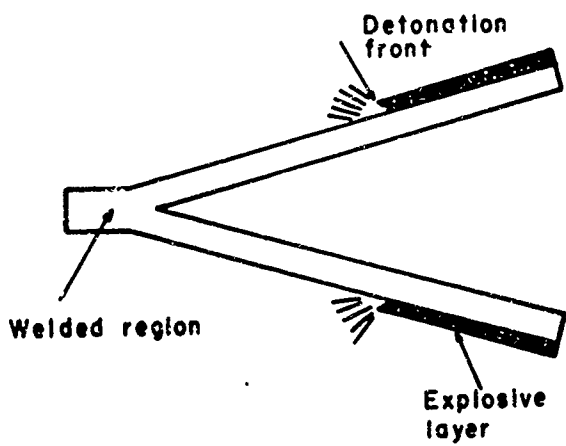

Figure 21 Experimental Arrangement for Explosive Welding of Plates

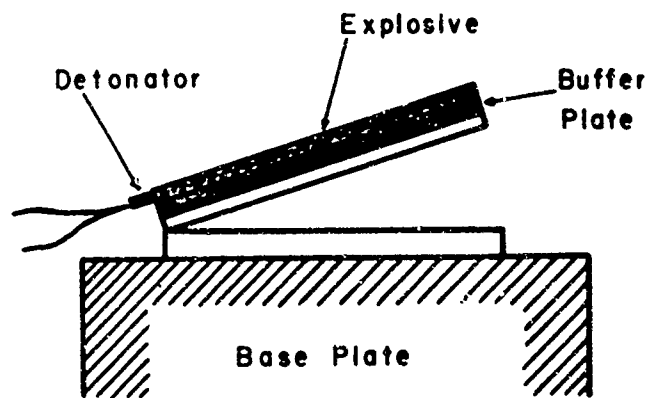

Figure 22 Cladding Operation



NEW METAL MANUFACTURING PROCESSES IN THE U. S. A.  
OF POSSIBLE APPLICATION IN LATIN AMERICAN COUNTRIES

by

F. R. Morral

Let me begin by admitting that since this is my first visit to South America, I cannot be specifically acquainted with your plants. Therefore, I am limited to more general considerations, based on broad economic conditions. This paper concerns, primarily, manufacturing processes for steel since the steel industry is considered in all countries to be the most important.

I understand that the purpose of this meeting is to increase productivity, in order to achieve the objective of a higher standard of living for the people of your nations. Increases in productivity will be due to invention and innovations, for which, of course, research and development provide the base. These innovations and developments will have to be adapted to your own resources and related to the particular needs of your people. You will not be able to just buy a plant or adopt a material. Rather, I believe, innovation or change will be necessary in any case. In the U. S. and other highly industrialized nations, the continued improvement in manufacturing, engineering, and industry depends to a large extent on the discovery of new manufacturing techniques and equipment which reduce the cost of metal making and fabrication.

The problems I foresee are: who is to support the effort necessary to bring about innovation? How can you successfully bridge the gap between research and production? Most of your organizations are small, and so I suspect that many of your firms cannot afford to invest the capital that may be necessary to introduce technical change. In fact, companies in the various countries may wish to consider forming international industry associations to be able to do it. There is evidence pointing to a high correlation between the size of the firm and its ability to assimilate scientific information, without which innovation is impossible. No doubt this stems in part from an inadequate scientific and technical awareness by management of the smaller firms. There is also the problem of heavy capital investment by small firms.

A serious problem may be the unavailability of qualified scientists and engineers engaged in research in your countries. Two others that you have, no doubt, are: unbalance of research support in the different segments of the industry and the difficulties of communication between those doing research and those who are in a position to apply the results. If researchers cannot get the results of research across to those who can make use of them, their effort is largely wasted.

Finally, there are economic factors that have an important bearing on the diffusion of innovations within industry: the firm's rate of growth, profit level, liquidity, and other nonmetallurgical factors.

### Processes Under Consideration

There are a number of alternative methods of producing useful metal shapes: (1) cast molten metal into a finished shape; (2) cast molten metal semi-continuously or continuously into ingots, bar, plate, rod, or other finished shapes, rails, etc.; (3) dissolve the ore, or concentrate, into an electrolyte and then make the finished shape by electroforming; (4) obtain the metal as powder, which subsequently is manufactured into the end shape by powder metallurgy.

Becoming more specific, metallic materials may be shaped or formed by one or a combination of the general methods indicated in Table 1. The choice depends upon the characteristics of the material, the dimensional accuracy required, and the expense permitted. Detailed information on the characteristics of these processes, their possibilities, and limitations is given in Tables 2 and 3.

Many of the difficulties encountered with the casting processes can be traced back to melting practice. The following points should be kept in mind:

- (1) Use and charge only clean material of known composition
- (2) Use only clean furnaces or crucibles for melting
- (3) Melt as quickly as is reasonably possible
- (4) Melt in a nearly neutral to slightly oxidizing furnace atmosphere
- (5) Do not superheat metal more than is absolutely necessary to insure adequate temperature as it is introduced to the mold
- (6) After removing from the furnace, skim the molten metal carefully without stirring or excessive agitation
- (7) Keep accurate temperature measurements of all melts

Foundry products generally have a poor reputation; however, by control, a great improvement can be achieved. For instance, voids caused by shrinkage during solidification are one of the primary sources of the low properties of, for example, aluminum castings. Surface defects on parts made in sand castings are common. Castells has shown that these defects can be eliminated by controlling

the pH of water-soluble constituents forming part of the sand <sup>(1)</sup>. Controlled foundry practice, proper melting and casting procedures, avoidance of oxide inclusions, proper grain-size refinement, heat treatment, and the use of radiography <sup>(3)</sup> help to produce guaranteed high-quality castings. An interesting innovation in making small castings is the self-heating crucible developed by Kemwell, Ltd., England. This consumable crucible does not require an outside source of heat and melts metals up to 3180 F. Ten pounds of many common engineering metals can be melted in 10 minutes <sup>(2)</sup>.

### Steel Mill Costs

Figure 1 is an outline of a traditional steel mill. Continuous casting of some steels and nonferrous metals is now done commercially (Figure 2). I note that you have already installed some units in Argentina, Mexico, Peru, and Venezuela.

A fully integrated steel mill costs between \$ 350 and \$ 600 per-ingot-ton-annual capacity, of which \$ 60-90 per ton is for the blast furnace. Economically, then, it seems worthwhile to consider one of the many methods of iron ore reduction other than the classical blast furnace (see Table 4). Generally, these require smaller investments, have greater flexibility of operation, and often employ a larger proportion of manpower. In addition, they do not require good metallurgical coking coal, which is relatively scarce in some of your countries. Among these methods, the following are most important: electric iron smelting, low shaft smelting, and other so-called direct reduction or direct iron methods which produce, in some instances, a high-grade product equivalent to scrap, and in others, some variety of pig iron with special characteristics. In Table 5, a comparison is made of the cost per-net-ton of iron, the total investment, and investment per-ton annual capacity <sup>(4)</sup>. Note that in the rotating-furnace process, the total cost is about half that for a blast furnace of the same capacity.

The electric furnace requires only one-half as much fuel reductant per ton of iron as a blast furnace. Of this small requirement, only one-third need be lump coke and the balance can be low-volatile coal or coke breeze. The Wiberg-Soderfors furnace operates efficiently in units with outputs as low as 100 tons per day.

### Steelmaking and Remelting of Sponge Iron

Steelmaking, on a small or medium scale, does not present the same problems as ironmaking. Summary cost data for both are included in Table 5.

Recently the British Iron & Steel Research Association announced FOS, a new fuel-oxygen-scrap process. This was developed successfully on a small unit. It can probably be used commercially for both small and large operations. It is

estimated that the cost of ingot making should be \$ 2.50-3.00 less than with electric steelmaking on a similar scale.

Figure 3 shows melting times, operation for various methods of making steel, and some advances (5). It may be seen that all processes are accelerated by using oxygen. Oxygen converters cut the cost of converting iron by \$ 4-8 per ton or roughly, in half.

Several techniques have been developed for the removal of gases from molten steel to reduce in-plant metal losses and improve the quality of the finished product. Efficiency of process, mechanical simplicity, and flexibility of operation are usually sought. Among the various new processes adopted by some American concerns are the Ruhrstahl-Heraeus and the Bochumer-Verein Processes. Vacuum degassing has been used primarily to remove hydrogen from large ingots of forging-grade steel. The Ruhrstahl-Heraeus Process also effects removal of oxygen and some nitrogen in the production of a wide variety of forged, cast, rolled, and continuous-casting plant products. This includes low-carbon strip for the automotive industry, for which vacuum degassing has only recently been considered.

The consumable-electrode vacuum-melting process is one in which electrodes made from a primary air-melted heat are remelted by an arc process. The product thus remelted solidifies in a water-cooled copper mold under vacuum. The cost of such material in the U.S. is about five times that of air-melted steel, and I do not believe the material is of interest to you. Similar results can be more economically obtained by: (1) stream degassing, (2) ladle degassing, and (3) the Dortmund-Horder (DH) process. In essence, each of these processes involves exposure of air-melted steel to a vacuum while the steel is still in a molten state. This usually results in a lower inclusion content, particularly those inclusions considered injurious to steels-oxides, silicates, and aluminates. Alloy additions can also be made under vacuum. This permits extremely close control of chemistry and permits producing variations in chemical analysis which heretofore were impractical. These processes have, I believe, great possibilities in your countries.

### Continuous Casting

Continuous casting shapes and solidifies the metal, readying it for semi-finishing in virtually one step (see Figure 2). This process, therefore, eliminates several costly steps as may be seen by comparing Figures 1 and 2 (see also Table 6). It reduces the number of personnel needed by half. For you in Latin America, it also may help solve some problems concerning ores, coke, and power.

Continuous casting may bring dramatic savings of \$ 29 per ton. Capital savings run as high as 50 per cent, and it is reported that operating economies are even greater than they appear. Not only are fewer people needed, but the scrap

loss is drastically reduced so the yield is raised from about 70 to more than 80 per cent. A material with a good surface can be obtained. The Roblin-Seaway Industries Inc., at Dunkirk, New York, claim to be able to produce steel billets on their continuous unit for \$ 30 a ton less than the \$ 115 per ton that is the current market price for billets. Theoretical figures show that savings could be double that. The mill is expected to turn out 120,000 tons of steel this year. Estimated savings: \$ 2 million a year over a conventional mill producing the same amount of steel, says Mr. Roblin, the president.

It is interesting to note that nearly 100 years ago (1865), Sir Henry Bessemer took a patent in England on pouring steel directly onto two water-cooled rollers and then withdrawing solidified plates. This technique, although not used on steel, is being used on some nonferrous metals which have lower solidification temperatures than steel. Incidentally, a modified technique is used, in which metal powder is shaped into sheet between two rolls. But more will be said about this in a companion paper.

Figure 4 is an outline of the continuous-casting installation. Although recent for steel, this type of setup has been used for semicontinuous casting of aluminum in the U. S. since the end of World War II.

Other methods have been adapted for special purposes. For critical bearings such as those used in aircraft engines, it is necessary to melt in vacuum. Induction-vacuum melting is the term applied to a process in which a cold charge is melted in an induction furnace and subsequently poured into ingots. This is essentially a small-tonnage operation.

Continuous casting of slabs for wide strip and heavy plate mills (1.5 m wide, 22.5 cm thick) has been discussed by Desfossez<sup>(6)</sup>. He describes operation of a recent continuous-casting mill in Germany and compares costs and space requirements of this with those of conventional mills.

The mold is the critical component of any continuous-casting system. There is a critical rate of descent for a billet of any given cross section. Exceeding this rate results in a solidification crater so deep that the skin may be warped and broken by the tensile and hydrostatic stresses exerted as the metal emerges from the mold. The rate of descent, or withdrawal speed, is further limited by the tendency of solidifying metal to stick to the mold.

Two-inch-square billets have been cast at speeds of 450 inches per minute. Figure 5 shows recent developments in the use of curved molds.

The reluctance of U. S. steel manufacturers to accept continuous casting stems from two misgivings: technologically, the process has not yet been applied to the production of all types of steel and, economically, most manufacturers are committed to operations into which continuous-casting methods are not easily assimilated.

Some plants are not ready to scrap their present, rather expensive, equipment. Now in 1964, however, National Steel announced building a mill containing the 3 devices for producing more steel at lower cost: oxygen furnaces, vacuum degassing, and continuous casting.

Continuous casting, so far, has not duplicated the combination of physical and chemical properties that characterize the "deep drawing" rimming steels. This is the type of steel used for automobile bodies, tin plate, and galvanizing sheets for many appliances. One plant in the U. S. hopes to produce a steel with good deep-drawing properties by vacuum degassing the liquid steel before it is poured into the ladle. If the steel does not have suitable deep-drawing characteristics on fabrication, failures and waste may result.

The investment in ingot-rolling machinery is so great that a profit-making primary mill of the continuous type must have a rated capacity of a million tons of steel per year. A continuous-casting plant, however, may have a much smaller capacity, so that the desired plant expansion can be accomplished in smaller increments than conventional equipment would efficiently allow.

The basic oxygen converter is best adapted to the needs of a continuous-casting machine because it can more readily supply the molten steel.

In summary, then, continuous casting offers capital savings as high as 50 per cent, with great operating economies. One company estimates an average cost of \$ 10 a ton for installation and an average saving of \$ 15 a ton in production costs. Under such conditions, a unit can pay for itself in less than four years. Plate and bar can be cast without the heavy-equipment blooming mill and part of the continuous mill. However, the ideal time for a producer to consider the use of a continuous-casting machine is when he is building an entirely new iron and steel mill, from blast furnaces and refining furnaces, through mill products. Thus, you, in starting, have an advantage.

#### Controlled Pressure Pouring

Another process which eliminates the need for a primary rolling mill, just as does the continuous-casting process, is known as controlled pressure pouring (see Figure 6) (8). The pressure-pouring mold often is capable of appreciable adjustments in the size of the section cast. As compared with continuous casting, very good surface and greater flexibility of cast-section sizes are obtained. This technique should be of particular value to the producer of specialty steels for whom sizes and annual tonnages are small, but the number of sizes required are large, as is found in high-volume plants. This process should be of interest to tool, stainless steel, and high-quality alloy steel producers, where special shapes are required. One such special shape might be a slab of metal 1 to 2 inches thick, 20 to 40 inches wide, 60 to 96 inches long, which then would be directly worked, either hot or cold, to final size. This technique has been very successful on some

difficult-to-work metals, such as superalloys, cobalt and nickel base, and refractory metals, tungsten, etc.

To obtain the desired mechanical and surface properties due to working, a reduction in size of at least 10 to 1 is required. Thus, the size of any precast or continuously cast slab which is destined for a secondary rolling operation must be kept sufficiently larger than the final bar, billet, shape, or sheet to allow adequate working.

The concept of the operation is simple. A ladle of steel is lowered into a chamber. A ceramic pouring tube attached to the chamber cover is placed over the ladle and the assembly lowered until, at the sealing level, the tube reaches within a few inches of the ladle bottom. The cover assembly is then clamped in position by hydraulic rams, and a mold assembly is placed over the pouring tube on top of the tank cover. Pneumatic pressure is applied to the chamber in which the ladle rests and forces molten steel up the pouring tube into the mold cavity. Once pouring begins, pressure is somewhat reduced to control the rate of flow. When the mold is filled, a special stopper arrangement seals off the pouring tube from the mold and the pressure is then reduced to normal in the ladle chamber. Either the ladle chamber or the mold will then move away, depending on plant design, and another empty mold will be sealed on the top of the pouring tube; the process then is repeated. The entire cycle is rapid, a matter of a very few minutes, and size changes in the mold are compensated for by use of differing pouring-tube sizes. The large mold, for example, is fed at a much greater rate per minute than are small wheel molds.

Several years ago, an interesting process using pig iron was developed by Stora Kopparbergs Bergslag A. B. (9). The process (see Figure 7) consists of mixing 85 per cent granulated pig iron and 15 per cent high-purity iron ore concentrate. The mixture is packed in a box made of thin sheet steel and decarburized at 1100 C. Then, at 1100-1200 C, the box of granules is run in a standard rolling mill. This sheet shows good deep-drawing properties and welds normally. It can be produced for an estimated \$10-20 per ton less than for steel sheet made by conventional methods.

#### Properzi System - for Rod and Wire

For continuous casting and shaping of nonferrous metals such as lead, aluminum, copper, and zinc, the Properzi system (see Figure 8) is interesting. Three units are now operating in Latin America, producing conductor-grade aluminum rod. Two models are available; on the small unit, 3,700 pounds per hour of 3/8-inch-diameter E. C. aluminum rod can be produced; while on the large unit, up to 9,000 pounds per hour can be produced. On this unit, also, about 10 tons per hour of copper rod can be produced. In some quarters, it is believed that this method of producing conductor redraw rod will render obsolete the now conventional method<sup>(7)</sup>.

The unit consists of two major pieces of equipment -- a rotary casting machine and the hot-rolling mill in tandem with the casting machine. The ring mold of the casting machine consists of a groove, roughly triangular, machined in copper, bounded over an arc of 150 degrees by an endless steel belt which forms a flat side (the top) of the mold. Molten metal moves from a holding furnace and passes through a cast-iron spout where the metal is deposited onto the wheel. This rotates in a clockwise direction. The sheeted metal passes through a water-cooling sequence, then leaves the casting wheel as a solid at the 7:00 position.

The wire emerges from the 17th stand at a diameter of 0.300 inch. Larger sizes of wire can be made by reducing the number of stands used.

A wide variety of problems can occur during solidification -- laps, seams, splits, fins, large slivers, scabs, roll marks, neckdowns, enfolding, or off-round. Smearred or embedded oxides also may be visible. Laps, scales, folds, cracks, and covered seams occur just below the surface.

These problems must be detected and controlled to produce quality products. The cost of a unit is about \$ 450,000 for the caster, furnace, and supporting equipment. No licensing or royalty payments are involved (Steel, March 30, 1964, p 133).

### Working

In 1938, the Krause mill was proposed <sup>(10)</sup>. It was then ahead of its time, but now bears careful consideration particularly because of the new materials available for rolls. Figure 9 shows the principle of operation. The heavy plate is introduced between two rolls which are forced to come closer together as they move along the inclined plane, thus essentially drawing and rolling the small bite of the plate taken and forcing reduction.

The use of sonic and ultrasonic vibration in controlling grain size during solidification of steel and nonferrous metals may be of interest to you. A recent summary report indicated that, for U.S. producers, grain refinement by sonic or ultrasonic treatment may not be economically attractive for steels going into everyday applications. It could however, be a very acceptable method for avoiding or minimizing undesirable properties attributed to banded structure. Incidentally, this technique seems to hold much promise for grain refinement of weld metals. Considerable work, both of a fundamental and practical nature, is necessary.

In the past few years, a number of new forming techniques have been developed. They are listed and compared with conventional techniques in Table 7. In a study of hard-to-form materials it was found that some showed increased formability at high velocity (up to 1000 ft/sec). Ductility was higher for some of these materials when this forming was done at temperatures other than room temperature. (W. W. Wood, Product Engineering, September 30, 1963, p 713). In ad-



dition, stainless alloys, light alloys, superalloys, and refractory alloys (Mo, W, 10-10 Cb) were tested.

The application of ultrasonic energy to conventional metalforming and melting operations is sufficiently promising that the technique merits your attention<sup>(11)</sup>. Data indicate that ultrasonic energy offers metalworking greater speeds, lower forces, and improved surface finishes.

These new high-energy-rate methods require considerably lower capital investments, produce parts to closer tolerances and with unusual material properties, and offer the ability to form high-strength and even brittle materials. The distinguishing characteristic is that work is performed during a rapid release of energy. Some of the techniques require special precautions, but the advantages far outweigh the hazards.

Liberating large amounts of energy at high rates can produce different effects on different metals. High explosives, propellants, gas mixtures, and high-pressure gas may be used in explosive-forming techniques. In the electric-discharge type of high-velocity metalworking techniques, three processes have been developed: (1) exploding wire, (2) spark discharge (see Table 7), and (3) magnetic field. The forming can be done in either a liquid medium or in air. The working velocity in these techniques is greater than 30 feet per second (see Table 7). In addition to metal forming, these techniques have found use in hardening, welding, metal removal, and powder compaction.

High-energy-rate forming (HERF) has permitted cost savings of 30-50 per cent. Difficult metals, thin walls, fine tolerances, and complex shapes are formed in a single blow.

Electric-spark forming is now a production tool in the U. S. A. A prime feature in the economics of this process is tooling, which saves half the cost. This process will make complex, even severe, shapes to fine tolerances. Spark forming makes parts in a 10-second cycle. Cleaning, after forming, is possible in operation because the spark energy and shock wave homogenize oil in water.

Magnetic forming has a good chance in the production of small parts. In tube expanding or swaging, shape control is excellent and there is no springback.

Ausforming, a thermomechanical process, is of particular interest because of the good properties obtained. Data obtained on several steels will be presented in a companion paper. The steel is deformed while it is still austenitic (in the unstable austenite range) and then allowed to transform to martensite. A high strength level, together with satisfactory ductilities, is obtained.

Heat Treating

To develop the maximum properties of an alloy, heat treatment may be necessary. These may be classified as follows:

Steels (see Figure 1.0)

Annealing: process, stress-relief,  
bright, "cyclic"

Normalizing

Austenitizing

Hardening: patenting, austempering  
martempering, ausforming

Tempering

Carburizing

Nitriding

Other Alloys

Solid-solution treatment

Precipitation treatment or  
aging

Cast Iron

Malleabilizing

I have been actively engaged in heat treating metals and alloys in salt baths. About 15 years ago, I became convinced that this processing technique had great possibilities because it could be applied to small or large processing runs. Although control is necessary, it is not difficult<sup>(12)</sup>. A basic knowledge of the chemistry permits use of simple means of control which will minimize any difficulties<sup>(13)</sup> (see Tables 8 and 9). Salt baths are a dependable and economical method of heat treating. Heat transfer is rapid and the process is applicable to most metals. It should be suitable for the new techniques of austempering, ausforming, and martempering steels.

Salt baths are useful for cleaning surfaces which have refractory oxide films. The chemical surface may be changed by carburizing, decarburizing, and cyano-nitriding. Other elements may also be applied to the surface by the use of salt baths and may be encouraged to diffuse into the surface of the part.

Machining

Machining is a well-known manufacturing process. New and unconventional techniques are given below:

Principle

Electrical-discharge  
machining

Process

Vaporization of workpiece by high-  
frequency electric sparks

<u>Principle</u>	<u>Process</u>
Electromechanical machining	Electrolyte dissolves reaction products formed on workpiece by electromechanical action
Chemical milling	Controlled attack of workpiece with suitable chemical reagents
Ultrasonic machining	Abrasive particles activated by tool vibrating ultrasonically remove workpiece material by impact
Electron-beam machining	Vaporization of workpiece by impinging high-energy electron beam
Plasma arc (and laser) machining	Melt metal, blow metal out of groove by angling torch

### Powder Metallurgy

Powder metallurgy was long considered an expensive method limited to relatively small shapes because of pressures required. However, there is now renewed interest in this process. Table 10 lists its advantages. Metal parts are formed by compacting metal powders to a certain shape and size and then sintering the compact at elevated temperatures (below the melting point of the main component) in order to obtain a material of the desired physical properties.

Frankly, I envy you engineers operating in Latin America. You have ahead a wonderful opportunity to use your creativity and know-how as you design and make operative new industries and adapt processes best suited to your local conditions, raw materials, power sources, needs, and economics. With largeness comes a certain restriction of innovation, with specialization comes a narrowing. It is in this younger stage of development, in which you now find yourselves, that the most ingenious and creative work can be done. Your creativity and skill today can bring great economic and technological advances to your countries.

## REFERENCES

- (1) Castells, J., La Fonderie Belge, 1960, pp 141-146, 167-174, 189-195, 234-239; Inst. Hierro y Acero, 13, 1960, pp 60-75
- (2) Iron and Steel, October, 1963, p 493
- (3) Can. Met. Quarterly, 1963
- (4) Contractor, G. R., and Morgan, N. A., Iron & Steel, December 19, 1963, pp 586-591
- (5) Schenck, H., Stahl und Eisen, 83, 1963, p 1688
- (6) Desfossez, P., J. Iron & Steel Inst., 200, October, 1962, pp 786-804
- (7) Russell, J. B., and Nichols, F. R., J. Inst. of Metals, 87, 1959, pp 202-219; Russell, J. B., Wire & Wire products, October, 1961
- (8) Industrial Heating, January, 1964, pp 74-76
- (9) Iron Age, June 27, 1957, pp 97-100
- (10) Knight, H. K., Materials and Methods, 23, January, 1946, pp 120-122; Iron & Steel Engr., August, 1938, pp 16-29; Steel, October 9, 1944, pp 248, 326; Keller, J. D., Steel, June 18, 1948, pp 108-123; Steel, June 25, 1948, pp 135-139, 173-174
- (11) Defense Metals Information Center Report No. 187, August, 1963
- (12) Morral, F. R., and Schaufelberger, F. A., Wire & Wire Products, Sept. 1953, pp 889-893, 921
- (13) Barber, S. J., Metals Engrg. Quarterly, 3 (4), 1963, pp 1-4
- Iron Age, October 31, 1963, pp 104-105
- Magnolo, G., The Canadian Mining & Metallurgical Bulletin, January, 1964, pp 57-62; Metalworking, Jan. 14, 1964, p 6
- Bor'chenko, M. C., Continuous Casting, Butterworth, London, England (1961)
- W. W. Wood, Product Engineering, September 30, 1963, p 713
- Morral, F. R., Wire & Wire Products, January, 1949, pp 39-47, 152-159, 235-243

REFERENCES TO ACTIVITIES IN LATIN AMERICA

- (1) Latin Steel, The Tide is Rising, S. D. Smoke, *Steel*, September 30, 1963, p 36
- (2) Where Metalworking Will Grow in Latin America, S. D. Smoke, *Steel*, Oct. 7, 1963, p 72
- (3) Use in the Rio Grande do Sul, H. C. Pfeifer, *Jnl. Iron & Steel Inst.*, March, 1964, p 283
- (4) Direct Reduction in Venezuela, *Iron Age Metalw. Int.*, 2, Oct. 26-27, 1963
- (5) Present and Future of Direct Reduction Processes in Latin America, P. W. Chase and D. L. McBride, *Blast Furn. Steel Plant*, 51, October, 1963, pp 868-878, 897
- (6) Strategic-Udy Process at Orinoco Steel Plant, Corp. Venezolana de Guayana, *Brit. Steel.*, 29, August, 1963, p 284
- (7) Strategic-Udy in Venezuela, *Met. Bull.*, July 16, 1963, pp 14-15

TABLE 1. METHODS FOR SHAPING OR FORMING MATERIALS

- 
- I. Casting While Liquid Into Molds
- (A) Gravity casting (with little or no added pressure)
1. Sand (green and dry), shell, plaster, investment-casting mold
  2. Semipermanent molds
  3. Permanent molds
- (B) Centrifugal casting-symmetrical or small unsymmetrical objects
- (C) Direct casting or continuous casting of plate, sheet, bar, or rod
- (D) Die or pressure casting
- II. Working (Hot or Cold), Heading, Piercing, Drawing (Wire, Tubing), Cupping, Forming, Spinning
- (A) Hot-rolling mills -- blooming, billet, continuous, or Morgan mills (two-, three-, or four-high cluster mills)
- (B) Cold rolling -- continuous, tandem, Steckel, Krause
- (C) Forging -- hammer, press, or die (open, closed), upset swaging
- III. Extruding (while in a very plastic condition at a suitable temperature either just below the melting range or, with some metals, close to room temperature)
- (A) Hot extrusion
- (B) Cold extrusion of Hooker process
- (C) Impact extrusion
- IV. Miscellaneous
- (A) Stamping
- (B) Machining
- (C) Electroforming
- (D) Powder metallurgy (May use extruding or roll compacting)
- (E) Joining -- soldering, brazing, welding
-

TABLE 2a. DESIGN FEATURES OF METAL FORMS

Form	Choice of Materials	Complexity of Part	Maximum Size	Minimum Size	Mechanical Properties	Precision, Tolerances	Special Structural Characteristics	Surface Smoothness	Surface Detail	Remarks
Sand Castings	Wide—ferrous and non-ferrous metals	Considerable—holes, bosses, flanging parts	Great—largest forms made are sand castings	1/2 in. in smallest practical section	Fair to high depending upon metal cast	±1/16 to 1/8 in./in. closer at extra cost	Good bearing structure	Poor	Poor	Usually require some machining before use
Shell Mold Castings	Wide—same as above except low carbon steels	Moderate—limited by mold removal problem	<60 in. square. Best for smaller parts	1/2-in. sections	Good—little porosity, few gas inclusions	±0.003-0.005 in./in.	High quality for cast metals	Good	Good	Considered best of low cost castings
Permanent Mold Castings	Restricted—brass, bronze, aluminum	Limited—restricted by use of rigid molds	Moderate—50 lb is practical limit in aluminum	1-oz. sections as thin as 0.1 in.	Good—high in centrifugal castings	±0.01-0.05 in.	As above	Good	Good	Large quantities allow productive economies
Plaster Mold Castings	Narrow—brass, bronze, aluminum	Considerable—mold destroyed in removal	Moderate—up to 15 lb for most materials	Small—1/8-in. sections possible	Fair	±0.010-0.005 in.	—	Good	Good	Little finishing required
Investment Castings	Wide—includes materials hard to forge or machine	Considerable—very few limitations	Moderate—best for parts under 2 lb	Small—sections down to 0.030 in.	Good	±0.005 in./in. common, ±0.002 in./in. possible	High quality for cast metals	Excellent	Excellent	Best for parts too complicated for other casting
Die Castings	Narrow—zinc, aluminum, brass, magnesium	Considerable—though costly dies might be required	Large—up to 75 lb in aluminum, 200 lb in zinc	Sections as small as 0.025 in.	Fair	±0.001 in./in.	Special properties can be obtained through use of inserts	Good	Good	Most economical where applicable
Drop Forgings	Medium—many ferrous, nonferrous alloys	Moderate—limited by die restrictions	Large	Small as fraction of an ounce	High	±0.010-0.030 in. without joining	Grain flow provides toughness	Fair	Fair	Used where high strength is required
Press Forgings	Medium—best for non-ferrous alloys	Limited—but greater than drop forgings	Large—300-400 lb practical maximum	Smaller than drop forgings	High	±0.005 in.	Hot working gives structural advantages	Fair	Fair	Closer tolerances and greater complexity than drop forgings
Upset Forgings	Medium—many ferrous, nonferrous alloys	Limited to cylindrical shapes	Medium—9-in. bar about largest	Moderate—not comparable to casting	High	Medium—compare to press forgings	Grain flow provides toughness	Medium	Medium	Best suited to small parts
Cold Handed Parts	Narrow—confined to steel, highly alloy alloys	Limited—less flexibility than forgings	Small—7 in. by 1/2 in. dia usual maximum	Small—1/2 in. dia parts can be made	H <sub>u</sub>	±0.010 in. common, ±0.002 in. possible	Tough structure	High	Fair	High production rates
Continuous Cast Parts	Narrow—bronze, nickel, brass	Limited—can be complex in cross section only	Moderate—3 in. max dia	Moderate—1/2 in. for sections	Good to high depending on alloys	±1/4 in. closer on rounds	High quality for cast metals	Good	Only as part of contour	Provides long sections and complex shapes
Extrusions	Restricted—light metals, some steels, copper, titanium	Limited—can be complex in cross section only	Medium—3 to 10 in. max dia	Small—0.050-in. sections to aluminum and magnesium	Good	±0.005 in. common	Grain flow improves properties	Good	Only as part of contour	Sometimes used as blanks for other processes
Impact Extrusions	Narrow—aluminum, magnesium, some steel	Limited—must be concentric	Small—6 in. dia in soft alloy, 4 in. in hard	Moderate—1/2 in. dia smallest	High—metal cold worked	±0.001 in. common	Grain flow improves properties	Good	Good	Can eliminate machining
Roll Formed Shapes	Narrow—cold rolled steel, some aluminum	Restricted to thin and uniform cross sections	Large	Sections from 0.125 in. up	Good	±0.002 in. common	Cold work improves properties	Good	None	Requires large quantities
Stamped and Press Formed Parts	Wide—all workable metals	Moderate—some design restrictions	Large	Small—sections as thin as 0.003 in. possible	Good to high	Good—to ±0.001 in. common	—	High	Good to excellent	Extremely low cost in quantity, otherwise moderate
Metal Powder Parts	Moderate—iron, steels, nickel, brass, nickel alloys, refractory metals	Limited—powders flow poorly, do not transmit pressure	Small—parts less than 4 in. square best	Small—<1/4 in. dia possible	Fair to good	Good—±0.001-0.005 in. common	Porosity can be controlled and complex materials formed	Fair	Fair	Can use materials not formable by other processes
Spinings	Wide—many sheet metals	Limited—cylindrical or concentric shapes	Large—up to several feet in dia	Moderate—1/2 in. dia in pipes less than 0.040 in.	Good	Fair—±0.015-0.060 in. common; better at added cost	Grain flow, cold work improve properties	Good	None	Good for large pieces or short runs
Screw Machine Parts	Wide—best suited to highly machinable metals	Moderate—limited to rotational shapes	Medium—up to 6 in. long, 2 1/2 in. dia	Small—<1/4 in. dia	High	±0.001-0.005 in. possible	—	Excellent	Good	High production rates, low cost
Electroformed Parts	Narrow—iron, copper, nickel, silver	Great—extreme complexity possible	Limited—1/2 in. sections can be built up	Small—0.005 in. or less	Fair—lower than wrought iron properties	High—±0.002-0.0002 in. common	—	Excellent	Excellent	Best when complexity and accuracy essential
Yieling	Wide—any ductile metal available in tubular form	Limited by sectional shapes of tubing	Usually 4 to 6 in. o.d.	Moderate—1/4 in. o.d.	Good—cold working improves properties	Good—depends on quality of tubing	Grain flow improves properties	Good	None	Good means of reducing costs
Welded and Brazed Parts	Wide—dissimilar metals can be joined	Great—extremely complex shapes	Unlimited	Moderate	Variable—depends upon components	Medium—not highly precise	Can combine parts with special properties	Depends on components	None	Often needed to meet design requirements

TABLE 2b. COMPARATIVE DATA TO PROCESS HOLLOW OR SOLID NONCONCENTRIC SHAPES (a)

RELATIVE PROCESS COSTS: IN PRODUCTION QUANTITIES

	PROCESS	PIECES PER HOUR	TOOLING		LABOR	MAT'L WASTE	10	100	1000	10,000	100,000
			Low	High							
C	Sand	1 to 20 up to 30									
A	Die	20 to 300 up to 550									
S	Centrifugal	1 to 5 up to 50									
T	Permanent mold	10 to 360									
I	Shell molding	10 to 75									
N	Investment	80 to 1500/day									
G	Plaster mold	5 to 10									
	Powder metallurgy	100 to 4000									
	Impact extrusion	500 to 7200									
	Continuous extrusion	2 to 700 ft/min									
	Roll forming	50 to 250 ft/min									
	Electro forming	Note 2									
	Brake forming	5 to 500									
	Die forging	10 to 500									
	Roll forging	1000 to 3000									
	Stamping	To 12,000									
	Wire forming	1500 to 30,000									
	Contour forming	60 to 100									
	Planing	-									
	Broaching	3 to 2000									
	Flame cutting	To 60 in./min.									
	Shaping	1 to 6									
	Milling	1 to 100									
	Contour sawing	2 to 20									

(a) Ref: Product Engineering, March 2, 1964, 48-49.



TABLE 3. GENERAL CHARACTERISTICS OF CASTINGS

Type ↓	Cost				Time*	Size			As-Cast Finish, rms*
	Labor	Equipment*	Material	Typical Pouring Rate, per hr <sup>b</sup>		Range	Avg. size <sup>d</sup>	Min Section Thk, in.	
Sand	High	Die low, tooling high, pattern 1/4 of die	Low	25	3-15 days	<1 oz to >200 tons	Few ounces to several tons	Special—1/16, small—1/32—1/8, large—1/16—1/4	Requires grinding, polishing, buffing
Precision Sand	Medium high	Low	High	300 per month	4-6 weeks	Max size not known. Present — <1 lb weight to 6 ft length	1-4	0.050	75-86
Permanent Mold	Medium	High	Nonferrous— high, gray iron—low	30	6-12 weeks	1 oz to 600 lb	1-10	0.090	100-125
Plaster Mold	Medium high	Low	High	4-5	4-6 weeks	<1 oz to >100 lb	3-5	0.040-0.060	50
Investment	High	Varies with quality of pattern die necessary	Wide range	Generally low; higher with plas- tics pattern	4-6 weeks	<1 oz to 25 lb —wax or plas- tics; >100 lb— frozen mercury	Up to 1	0.030	60—wax and plas- tics; 40— mercury
Die	Low	High	High	75-150 alumi- num, magnesium; copper-base; 300- 350 z.	8-14 weeks	<1 oz to 75 lb aluminum; <1 oz to 200 lb zinc	1/2-1	0.050	50

\* Dies, patterns and/or machines.

<sup>b</sup> These figures are general for one set of equipment. Actual rate of casting production depends on number of cavities per mold.<sup>c</sup> From complete design to production.<sup>d</sup> Average size of competitive castings.<sup>e</sup> Finish obtainable in limited areas.

TABLE 4. IRON MAKING PROCESSES

I.	Smelting	Shaft Furnaces	Conventional blast furnace; low shaft furnace (Demag-Humbolt) +
		Electric Furnaces	Tysland Hole*; Lubatti*; deSy Ghent <sup>+</sup>
		Electric Furnaces with Pre-reduction	Strategic-Udy*; Orcarb <sup>+</sup> ; Dwight-Lloyd-McWane <sup>+</sup>
		Rotary Kiln	Basset*; Stora Kopparbergs Bergslag
II.	Flash Smelting		Flame Smelting (Cyclosteel) <sup>+</sup> ; Jet Smelting <sup>+</sup> ; Diamond Alkali
III.	Direct Reduction (gas reductant)	Shaft Furnace	Wiberg-Soderfors; Lurgi Gailuser <sup>+</sup>
		Retort	Madars <sup>+</sup> ; HyL*
		Fluid Bed	Esso Little*; Nu-Iron <sup>+</sup> ; Armco H-Iron <sup>+</sup> ; Stelling <sup>+</sup> ; Magrigai
IV.	Direct Reduction (solid reductant)		Tunnel kiln (Hoganas-Sieurin) <sup>+</sup> ; Krupp-Renn; Bureau of Mines; R-N <sup>+</sup> ; Bruckner*; Urquehart <sup>+</sup>

\*Commercial

+Semi Works

‡Pilot

Source: Iron &amp; Steel, Dec. 1963, p 586

TABLE 5. COST COMPARISON OF VARIOUS PROCESSES

	<u>Cost per Net Ton</u>	<u>Total Investment or Ton-Year</u>	<u>Operating Costs</u>	<u>Remarks</u>
<b>A. <u>Iron Processes</u></b>				
Wiberg Sodefors	\$62	\$1,600,000		1958
Hy L		\$30	\$10	1958
Krupp-Renn	\$40-46	\$42-50		
R-N	\$43	\$19,500,000	\$4	
Strategic-Udy Submerged arc Electric		\$60-75		300 t/day
Rotating furnace Stora-Koppar- bergs Bergslag)		\$2,000,000		For 800 t/day For 130 t/day
<b>B. <u>Steel Processes</u></b>				
L-D Basic hot-blast		\$23-39		
Cupola	\$40-50	\$7-10		70,000 t/yr or more
Kalds process FO <sub>2</sub> S (Bisra) Plasma arc melting				

**Sources:**

G. P. Contractor and W. A. Morgan, Iron & Steel, December 1963, pp 586-591

Iron Age, October 31, 1963, pp 104-105

Fuel-oxygen-scrap process (Metalworking, January 14, 1964, p 6)

G. Magnolo, The Canadian Mining & Metallurgical Bulletin, January 1964, pp 57-62

TABLE 6. COMPARISON OF CONVENTIONAL AND CONTINUOUS CASTING

Conventional Casting	Continuous Casting
Melting furnace	Melting furnace
Ladle	Ladle
Crane transport to casting area	Crane transport to casting area
Ingot molds	Continuous casting machine
Rail transport to stripper	Semifinished products
Stripper	
Rail transport to soaking pits building	
Crane to soaking pits	
Crane to blooming mill	
Blooming mill	
Semifinished products	

TABLE 7. COMPARATIVE RATES OF ENERGY RELEASE

Type	Equipment size	Time, sec.	Power, ft-lb/sec	Remarks
Press	80 in/min, 1 in. stroke, 660 ton	0.75	158,000	
Hammer	180 in/sec, 1 in. stroke	$5.6 \times 10^{-3}$	20,000,000	
Pneumatic Mechanical	1200 in/sec, 1 in. stroke	$8 \times 10^{-4}$	140,000,000	
Electrospark (in liquid or air)	150,000 joules	$4 \times 10^{-4}$	280,000,000	Spark discharge: Spark jumps across electrodes submerged in fluid; creates shock wave. Exploding wire: Wire between electrodes vaporizes and converts to plasma, creating a shock wave.
Explosive (in liquid or air)	0.26 lb	$2.5 \times 10^{-5}$	4.4 billion	High velocity pressure wave caused by explosive deforms workpiece at high strain rate.
Electromagnetic Metal Forming				Rapidly changing magnetic field causes forces which move workpiece into die.

Note: 1 ft-lb/sec =  $1.82 \times 10^{-3}$  HP =  $1.36 \times 10^{-3}$  Kw.

TABLE 8. COMPOSITION OF COMMONLY USED HEAT-TREATING SALTS  
(Specification Mil. S-10699A)

Class	Constituent, wt %								
	NaNO <sub>2</sub>	NaNO <sub>3</sub>	KNO <sub>3</sub>	Na <sub>2</sub> CO <sub>3</sub>	NaCl	KCl	BaCl <sub>2</sub>	BaCl <sub>2</sub> plus SiO <sub>2</sub>	CaCl <sub>2</sub>
1	37-50	0-10	50-60						
2		45-57	15-57						
3				45-55		45-55			
4					15-25	20-32	50-60		
4A					10-15	25-30	40-45		15-20
5					40-60	40-60			
6						5-15	85-95		
7								98 min*	
8					3-7		93-97		

\*Class 7 salt shall be supplied in four forms containing the following amounts of rectifier, as specified: 7A--No silica; 7B--0.25 to 1.25 silica; 7C--1.5 to 2.5 silica; 7D--4.0 to 5.0 silica.

TABLE 9. WORKING RANGE AND PRINCIPAL USES OF SALT BATH LISTED IN TABLE 8

Class	Working Range, F	Principal Use
1	325 to 1100	Quenching and tempering steel
2	550 to 1100	Heat treating aluminum. Annealing and stress relieving of copper alloys
3	1150 to 1700	High-temperature tempering of low carbon steel. Annealing copper alloys
4	1100 to 1650	Wide temperature-range hardening and annealing of carbon steel
4a	1025 to 1400	Hot quenching and tempering of high speed steel
5	1300 to 1650	General heat treatment of carbon steels. Pre-heating bath
6	1650 to 2000	Annealing of stainless steel. Hardening high carbon-high chromium tool steels
7	1900 to 2400	Hardening high speed steels and certain high alloy steels
8	1650 to 2350	Hardening high speed steel and high carbon-high chromium steels

The composition range of the eight classes of heat-treating salts are given in Table 8. Table 8 is useful for government purchasing but I prefer a more inclusive classification, as follows:

1. Low-melting salts; oxidizing Class 1 and 2 (Mil. S-10699a)
2. Carbonate salts; alkaline, includes Class 3
3. Case-hardening and carburizing salts; cyanide mixtures
4. Neutral salts: (a) alkali metal chlorides, Class 5  
(b) alkaline earth metal chlorides, Class 4, 4a, 6, 7, and 8
5. Miscellaneous; Caustic mixes, glasses, etc.

TABLE 10. ADVANTAGES OF POWDER METALLURGY

1. <u>Applications properties</u>	2. <u>Production</u>
Close tolerances	Mass-production process
Density control	Fewer operations
Weight control	No scrap loss
High wear resistance	Cost reduction
Self-lubrication	Minimum machining
Parts may be plated	Minimum finishing
Parts may be hardened	



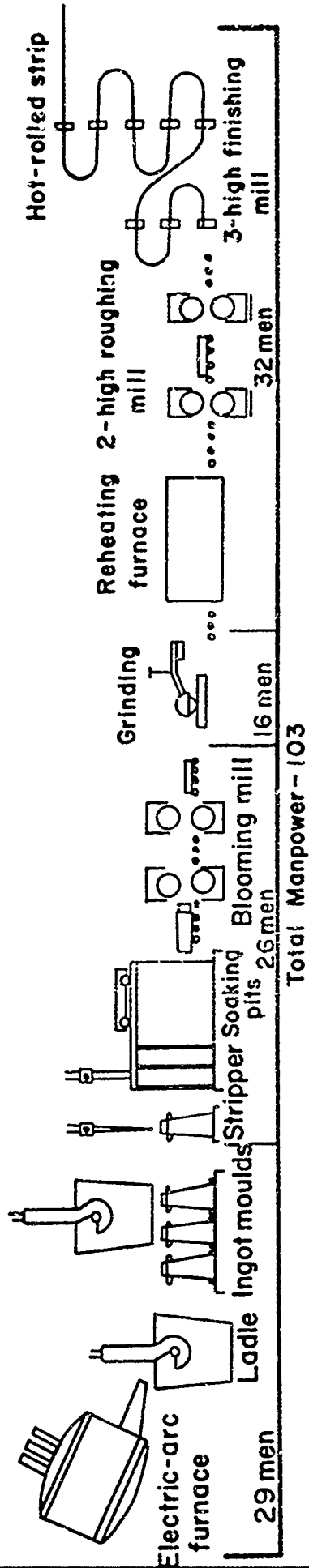

XXX-25

Figure 1 Schematic Diagram of a Steel Plant Using Arc Furnaces and Conventional Ingot and Rolling Facilities

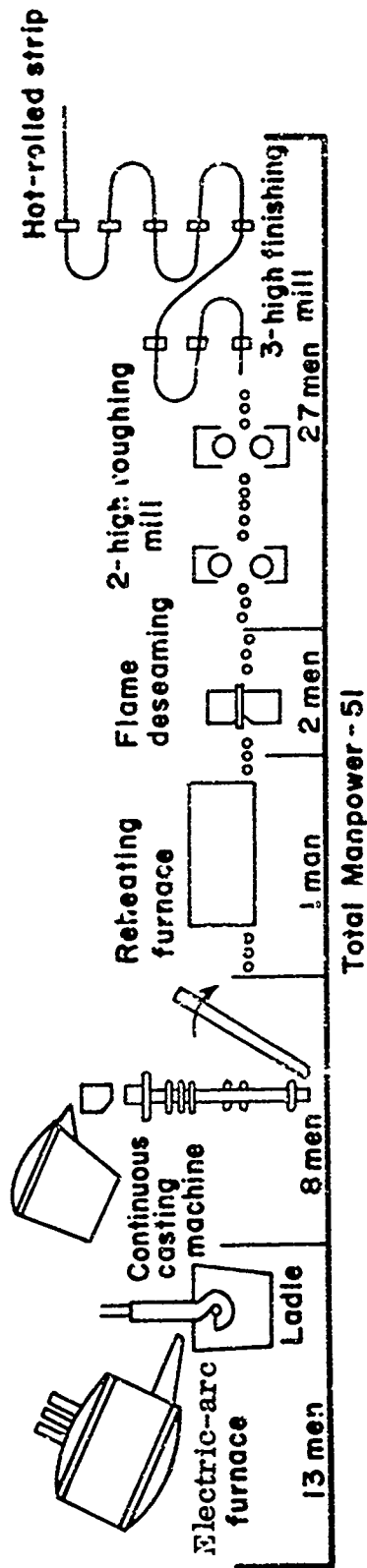

Figure 2 Schematic Diagram of a Steel Plant Using Arc Furnaces and Continuous Casting Facilities

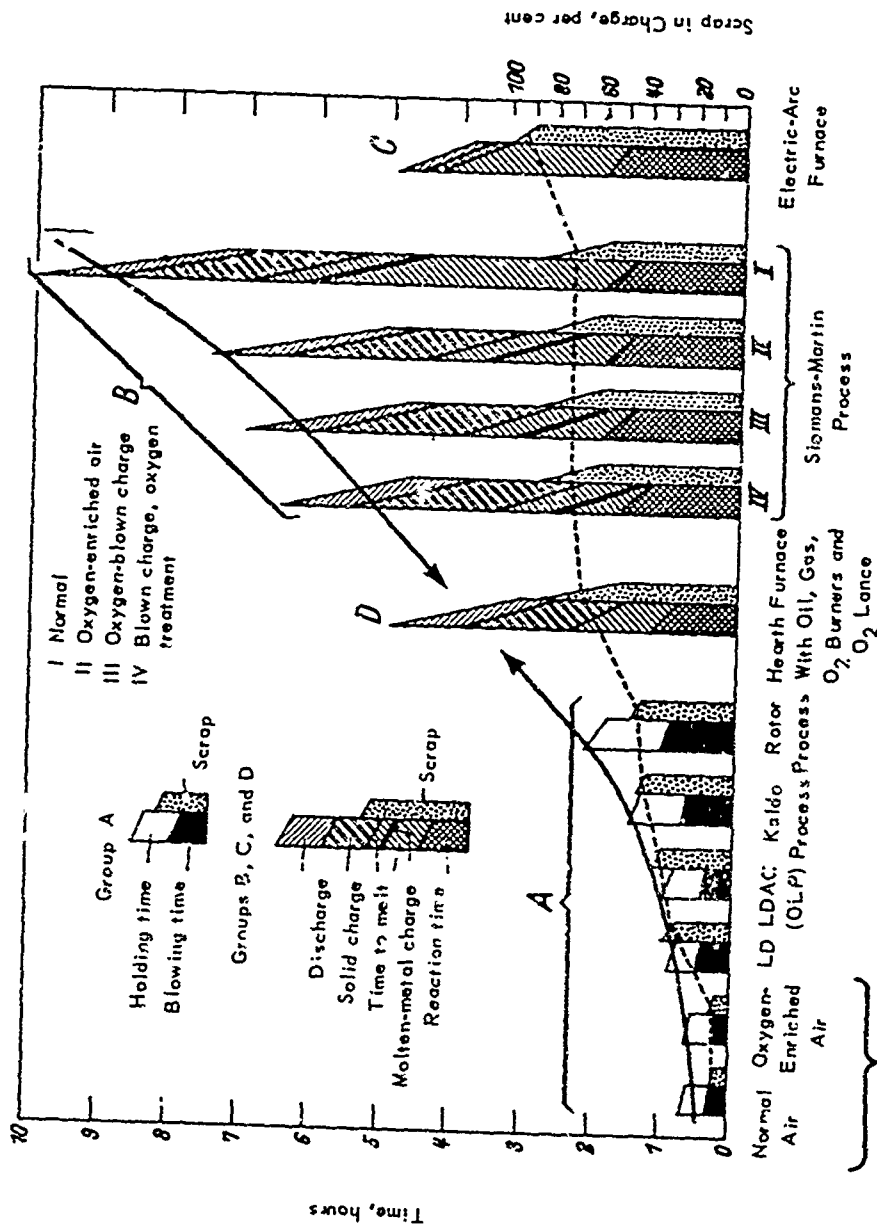

Figure 1 Comparison of Steel-Production Processes

XXX-27

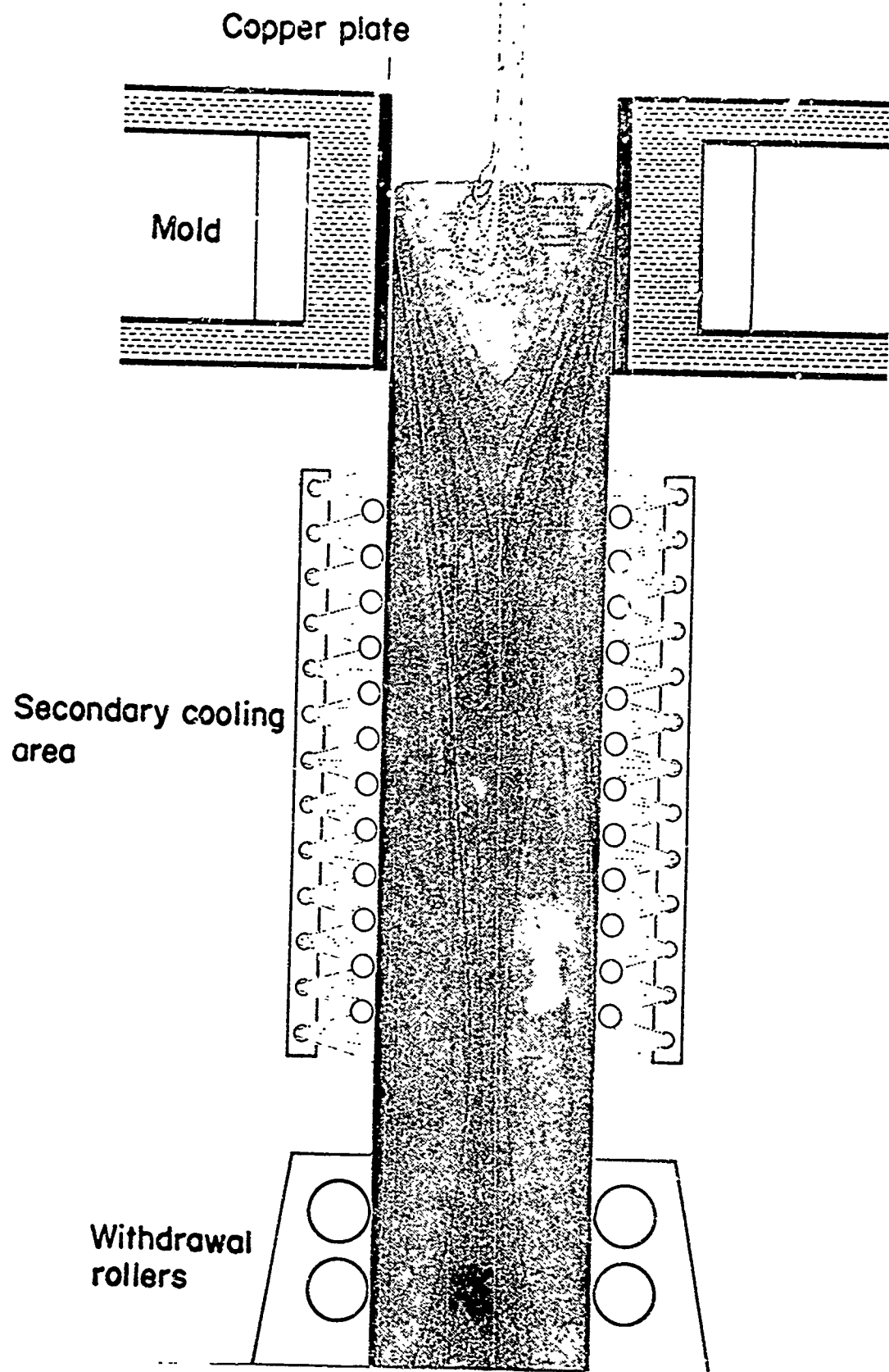

Figure 4 Continuous Casting of Steel

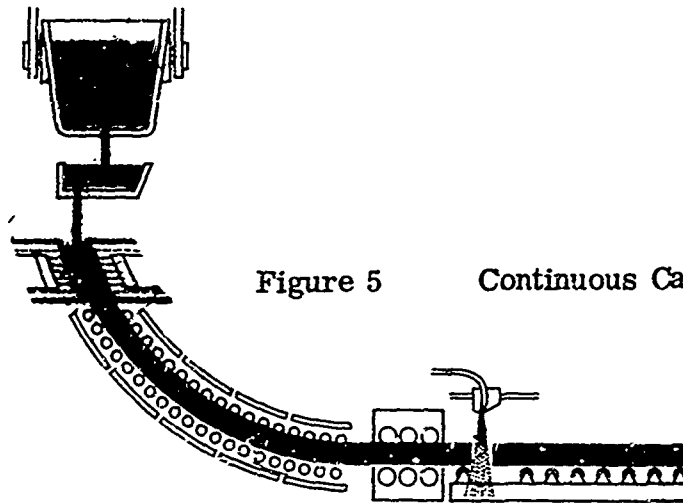

Figure 5 Continuous Casting of Steel

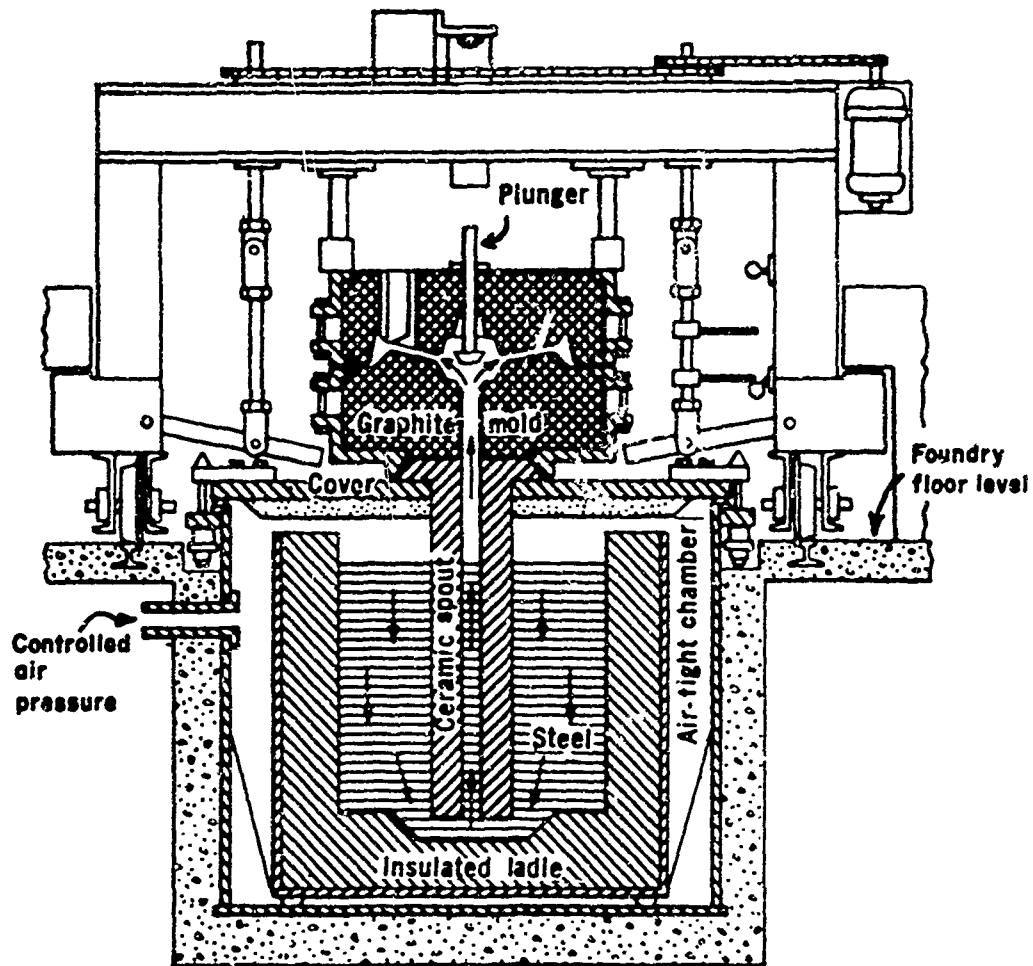

Figure 6 Process for Controlled-Pressure Pouring of Wheels With Suitable Molds the Process can be adapted to the Production of Steel Slabs

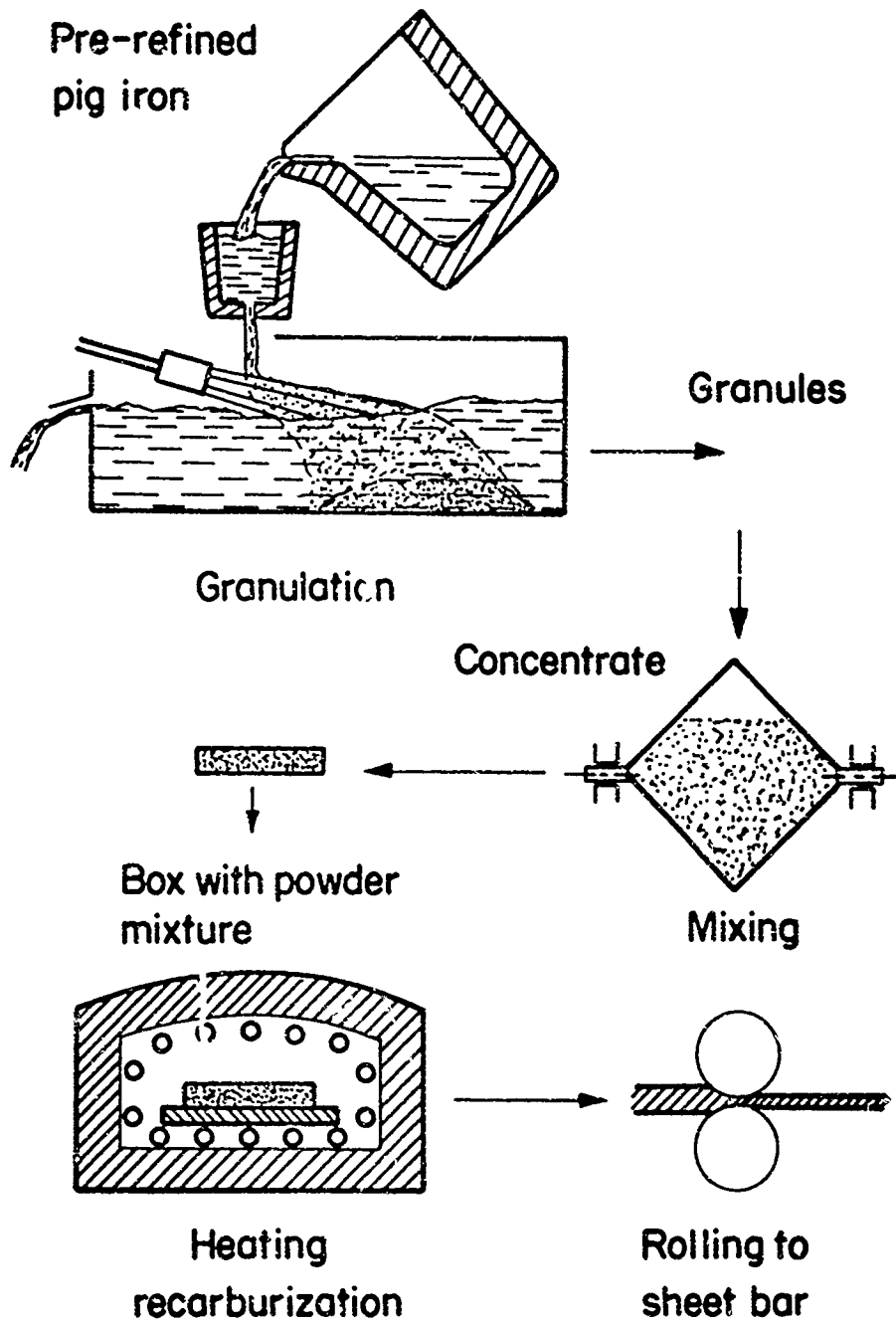

Figure 7 Steps in a Powder-Steel Process

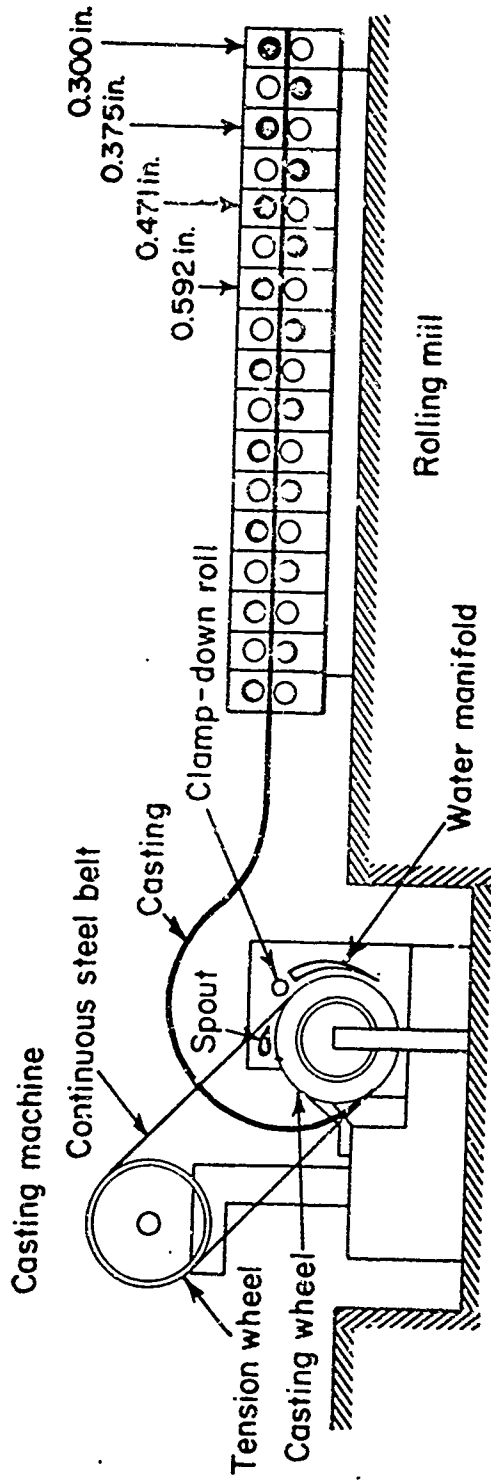

Figure 8 Casting Round Wire by the Properzi Process

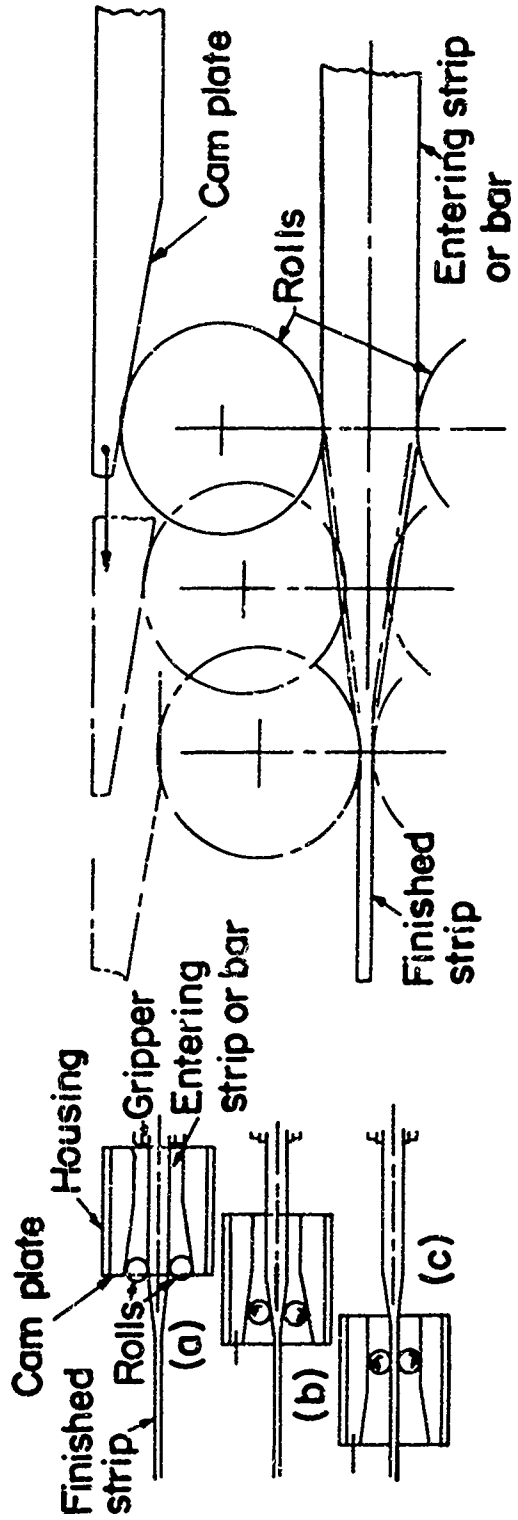

Figure 9 The Krause Mill

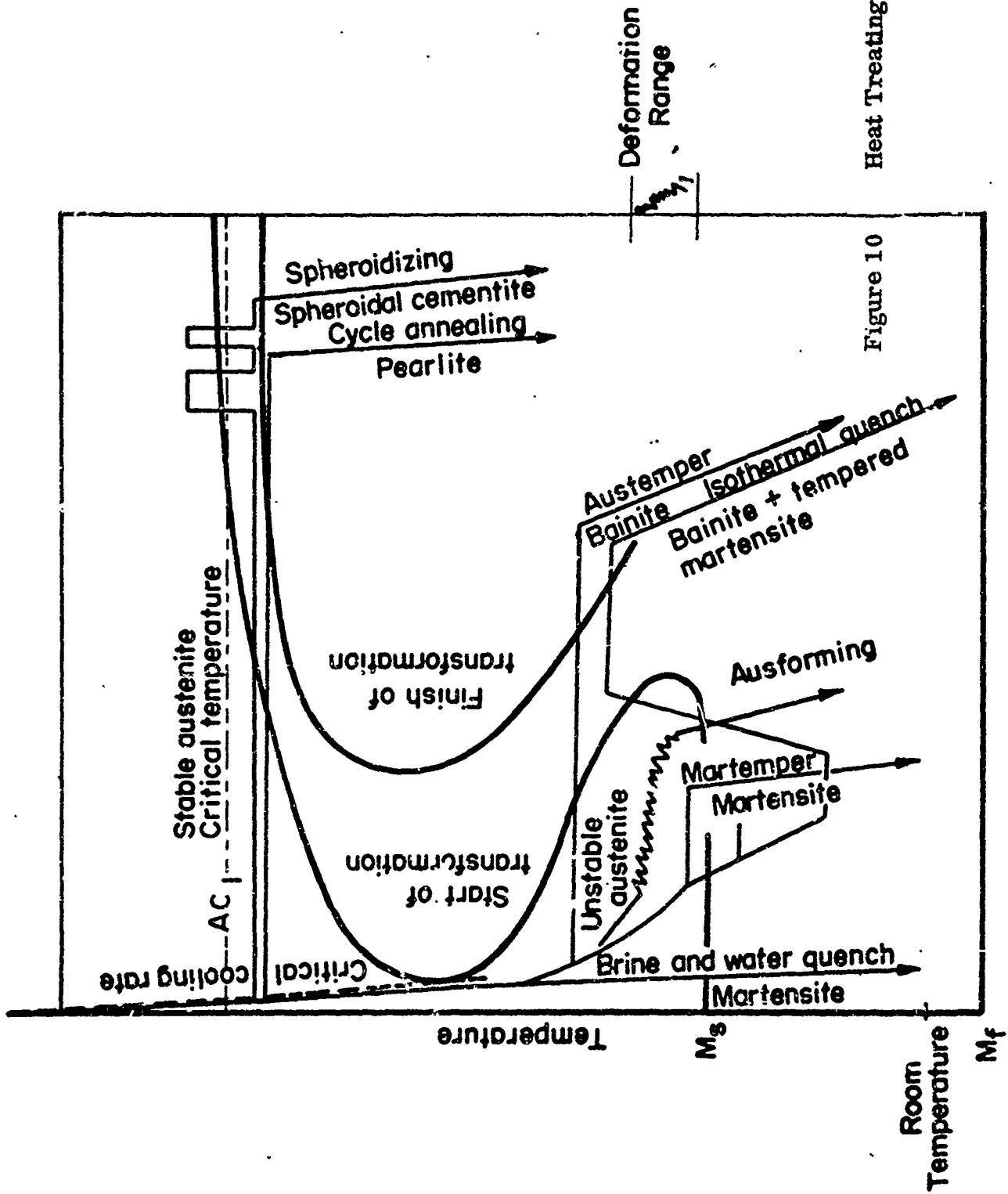

Figure 10



COLADA CONTINUA DE ALUMINIO

por Juan Luis Ciarlo y Roland Meillat

Introducción

En el presente trabajo hemos buscado mostrar, en forma concreta, el actual proceso de fabricación de Cables de aluminio-acero y almelec puesto a punto en CAMEA S. A. en sus modernas instalaciones de Villa Lugano - Capital Federal.

Teniendo en cuenta que la etapa más importante del proceso la constituyen la colada y laminado de la barra para obtener el alambre de  $\phi 9.5$  mm, se han desarrollado ambas operaciones en detalle, en tanto que las restantes de trefilado y cableado se mencionan a título complementario, dado que no difieren en líneas generales, de lo tradicional.

En lo fundamental, el proceso se basa en el denominado sistema Properzi.

Los primeros resultados obtenidos por Hilario PROPERZI en la colada y laminado de alambre de Pb (PF 327°C) condujeron a ensayar, con éxito, el mismo sistema para el zinc (PF 420°C) para pasar luego al Aluminio (PF 658°C).

Obtenido el alambre de aluminio se buscó entonces su adaptación para la utilización en la fabricación de cables conductores.

Las ventajas que presenta este sistema al evitar el precalentamiento intermedio de placas o barrotos antes del laminado o prensado, y la utilización de materiales y equipos mucho más livianos y veloces, con un menor costo de producción, habían despertado anteriormente el interés de varios investigadores.

Ya en 1858 Henry Bessemer proponía la colada directa del acero entre cilindros refrigerados, aunque lamentablemente con resultados poco alentadores.

Para el caso particular del aluminio merecen citarse:

- \* Máquina Hazelett - Para la obtención de bandas laminadas. La colada se efectúa entre dos cintas metálicas sin fin, paralelas y refrigeradas exteriormente por agua.

- \* Máquina Hunter Douglas - Similar a la anterior, para la obtención de bandas, presenta como diferencia el reemplazo de las cintas por cadenas de elementos de lingoteras articuladas refrigeradas individualmente por refrigeración con agua.
- \* Máquina Properzi - Para la obtención de alambrón. El metal es colado en la garganta tallada en una rueda de cobre refrigerada interiormente y cerrada a 180° por una cinta de acero enfriada exteriormente por agua.

Las 3 máquinas tienen como puntos comunes fundamentales los siguientes:

1. No existe desplazamiento relativo entre el metal en curso de solidificación y el molde.
2. El molde está completamente cerrado en toda su longitud.
3. El contacto entre el metal colado y el elemento refrigerado del molde se efectúa sobre una superficie relativamente importante. Por lo tanto las posibilidades de regular la refrigeración son amplias.

Los puntos enunciados permiten obtener un buen estado de superficie del producto colado y al no existir desplazamiento relativo metal-molde, se evitan los esfuerzos mecánicos sobre el metal en curso de solidificación, que pueden ser eventuales causas de fisuras o roturas, altamente nocivas para la transformación posterior.

Si bien luego de pacientes esfuerzos lograrse obtener un alambrón íntegro (libre de fisuras y sopladuras), quedaba aún por resolver el problema metalúrgico, que planteaba la calidad exigida para la utilización en el campo de la energía eléctrica.

Como veremos más adelante, la cuestión ha sido oportunamente resuelta y actualmente resulta posible -mediante el control y la regulación adecuada de las variables correspondientes- obtener una calidad que responde ampliamente a las exigencias de las normas internacionales.

Si bien este modernísimo proceso es conocido en algunos países del mundo, su presencia en nuestro país abre posibilidades insospechadas en cuanto a tonelaje y precios de alambre de aluminio o aleación.

Digamos que, al 31/8/64, CAMEA S.A. ha fabricado desde la puesta a punto del proceso -en 1963- más de 3.000 Km de cables de diversos tipos, equivalentes a un tonelaje global del orden de las 700 Tn y continúa con su programa de producción a fin de aprovisionar no sólo el mercado local sino la exportación hacia otros países del continente, en particular Brasil y Chile.

A continuación detallaremos nuestro proceso de fabricación que, en sus

grandes líneas responde al utilizado habitualmente en las usinas Pechinev en Francia, con las lógicas adaptaciones de una puesta a punto local, que permite igualmente mantener el standard de calidad que asegura al utilizador nacional y extranjero la regularidad de las características exigidas para este tipo de materiales.

### ASPECTOS TECNOLOGICOS DEL PROCESO

Tanto la elaboración del cable aluminio-acero como la del cable almelec se efectúan en las mismas instalaciones. Para el caso del Almelec se utilizan además dos hornos adicionales de tratamiento térmico (temple y revenido) indispensables para esta fabricación.

En el apéndice se incluyen las fichas técnicas de cada máquina con sus correspondientes producciones horarias aproximadas.

### FUSION

CAMEA S.A. cuenta para esta operación con modernos Hornos Gautschi de fusión, a gas natural, de 7 Tn de capacidad, equipados con 3 quemadores solidarios que totalizan un caudal horario del orden de los 200 m<sup>3</sup>/h. La marcha de los quemadores se regula automáticamente por un sistema de seguridad y la disposición estratégica de pirómetros de bóveda y de baño.

Por razones de calidad, como veremos más adelante, la composición de carga se efectúa preferentemente con 100% de metal nuevo - lingotes de A5C (aluminio conductor); Mg metálico y aleación madre AS 33 (aluminio-silicio 33%) para el caso del almelec.

La utilización preferente de lingotes de 1a. fusión permite, además de asegurar la regularidad y constancia de la composición química, reducir el ciclo de horno aumentando la velocidad de fusión, que puede estimarse en el orden de 2 Tn/h.

Completada la fusión se efectúa en el mismo horno el "tratamiento al flux" tendiente a eliminar las impurezas nocivas tales como el Titanio y el Vanadio, que inciden en forma importante sobre el aumento de la resistividad.

En cuanto al contenido de las demás impurezas, los valores máximos están asegurados por la calidad del aluminio de base y las precauciones que se toman tendientes a evitar la contaminación del metal en curso de transformación. Las temperaturas de fusión oscilan, según los casos entre 720 y 780°C.

## COLADA - LAMINADO

Ambas etapas se desarrollan simultáneamente mediante una sincronización adecuada de las instalaciones utilizadas. Ellas son:

### \* Horno Gautschi Eléctrico

De capacidad similar al horno de fusión de gas (7 Tn), éste es en cambio calentado por una serie de resistencias eléctricas colocadas convenientemente en la bóveda del mismo.

El consumo es del orden de los 80 Kwh y el calentamiento regulable sistemáticamente por pirómetros, ubicados en la bóveda y en el baño de metal líquido. Al igual que el horno de fusión es basculante a ambos lados por medio de un pistón hidráulico ubicado bajo el piso del mismo. Su peso es del orden de las 35 Tn.

El metal llega a través de una canaleta de transvase portatil, a la que es volcado haciendo bascular el horno de fusión.

El tiempo de transvase de 7 Tn es del orden de los 18 minutos.

En función del tipo de cable a fabricar (alu-acero o almelec) se mantiene el metal en el horno de colada hasta obtener la temperatura adecuada para cada tipo de material.

Resulta útil destacar que las características mecánicas y eléctricas exigidas para el alambre a diámetro final están, en el caso del cable alu-acero, íntimamente ligadas a las condiciones de colada y laminado de la barra, dado que la posterior transformación en frío (trefilado) se efectúa sin ningún tratamiento térmico adicional.

En el caso del almelec, las razones que rigen los parámetros de la colada obedecen fundamentalmente a la necesidad de obtener una barra sana en virtud de que, comparativamente con el aluminio, las aleaciones al Si Mg 2 presentan una mayor tendencia a fisurarse en caliente.

### \* Máquina de Colada Tipo Properzi

Si bien difiere ligeramente en sus dimensiones y aspecto exterior a la original Properzi, conserva en cambio sus características principales.

Está constituida por una rueda de colada, un recipiente o tanque intermedio entre el horno y la rueda, y un sistema de refrigeración interior y exterior de la misma.

\* Tanque intermedio

Se halla solidario con la rueda de colada, y ofrece la posibilidad de ser desplazado convenientemente hacia adelante o atrás para permitir la posición adecuada de la boquilla de colada en la garganta de la rueda. En nuestro caso la capacidad del tanque es del orden de  $\approx$  15 lts (40 Kg).

Su misión es la de mantener un nivel suficiente de metal que asegure una vena líquida regular y constante durante toda la colada.

El metal llega al tanque, construido en fundición de hierro, por medio de una canaleta ubicada debajo del pico de descarga del horno. Un mechero a gas permite aplicar un calentamiento continuo o intermitente a fin de mantener la temperatura del metal dentro de los límites pre-establecidos para cada caso.

En la pared situada al costado de la rueda se halla el orificio de salida donde se coloca la boquilla de colada, constituida en nuestro caso por un tubo acodado de dos piezas de fundición de hierro, cuya misión consiste en conducir la vena líquida hacia la garganta de la rueda.

A fin de mantener una colada "tranquila", sin turbulencias ni interrupciones de la vena líquida, es necesario mantener el extremo inferior de la boquilla levemente sumergido ( $\approx$  5mm) bajo el nivel del metal dentro de la garganta de la rueda. Ello se consigue accionando convenientemente el tapón cónico situado en el extremo anterior de la boquilla (dentro del tanque) por medio de un sencillo mecanismo de avance-retroceso; manejado por el mismo operario colador que regula de este modo el caudal de metal a enviar a la rueda en movimiento.

Teniendo en cuenta que el aluminio líquido disuelve el hierro de los elementos en su contacto, es necesario aplicar una pintura de protección a la canaleta, al tanque y a la boquilla de colada.

En el caso particular de esta última, la operación reviste cierto cuidado dado que la regularidad de la vena líquida está condicionada a una superficie interior de la boquilla perfectamente lisa, libre de granos o porosidades que puedan producir turbulencias o el ataque rápido de la misma, con los consiguientes inconvenientes.

Al igual que en la colada continua o semicontinua de placas y barrotes es necesario mantener el metal en movimiento por debajo de su piel de alúmina que lo cubre (colada en manantia!) para evitar el entranamiento de la misma película al romperse y de burbujas de aire que desmejoran la calidad del producto colado y originan inconvenientes durante la transformación posterior.

\* Rueda de colada

Está constituida por un anillo de cobre montado sobre dos discos de fundición de hierro refrigerados por dentro y accionados por un motor que le confiere un movimiento de rotación sobre su eje central.

En el anillo de cobre se ha tallado una garganta de sección trapezoidal de  $\approx 1000 \text{ mm}^2$ . La mitad de la garganta permanece cerrada por medio de una cinta de acero de bajo carbono, tendida en el borde opuesto por una polea loca del mismo diámetro de la rueda.

La tensión de cierre de la cinta de acero se logra mediante un tornillo sin fin.

La lingotera está constituida entonces por el sector de la garganta cerrado por la cinta y dada su extensión relativamente importante y la refrigeración exterior aplicada sobre la cinta a partir del contacto con el metal líquido, es posible regular con cierta amplitud la velocidad de solidificación a fin de obtener una barra íntegra y suficientemente plástica para favorecer la transformación inmediata en el laminador.

La velocidad de giro de la rueda es regulable oscilando alrededor de 3 rpm, lo que equivale a aproximadamente 10 mts de barra en ese lapso.

Si se tiene en cuenta que 1 mt de la barra pesa alrededor de 2,5 kg veremos que la producción horaria de la rueda oscila en los 1500 kg/h, lo que significa un ritmo de producción elevado además de otras ventajas, en comparación con los valores alcanzables por los métodos tradicionales, a los cuales es necesario agregar el precalentamiento del barrote o lingote a transformar; los recocidos intermedios, la limitación en el largo del alambrón a obtener y la utilización de máquinas y elementos de mayor volumen y peso.

A título ilustrativo digamos que para el caso de una colada de 7 Tn (que aún puede ser alimentada periódicamente en curso) se puede obtener un alambrón laminado a 9,5 mm de diámetro, cuyo peso es de  $\approx 200 \text{ gr/mt}$ , con un largo de 35 Km, sin cortes, en menos de cinco horas.

LAMINADOR SPIDEM

Presenta diferencias importantes con relación al original Properzi. En tanto que este último consta de 13 cajas de cilindros cruzadas y las secciones pasan consecutivamente de la forma triangular a la hexagonal, para terminar en sec

ción circular del alambrón, el Laminador SPIDEM presenta 8 cajas de cilindros también cruzadas y la sección de la barra pasa alternativamente de la forma oval a la circular terminando en ésta con el mismo diámetro final de 9,5 mm.

Las reducciones de sección entre cajas oscilan entre 20 y 30%, exceptuando la primera caja en la que se aplica una reducción del orden del 60% aprovechando la temperatura de entrada de la barra que es de alrededor de 450°C.

La sección de la barra a la entrada es de  $\approx 1000 \text{ mm}^2$  y luego de los 8 laminados sucesivos se obtiene el alambrón cuya sección es de  $\approx 70 \text{ mm}^2$ . Las velocidades de entrada y salida son respectivamente 10 y 120 mt/min aproximadamente, lo que equivale como hemos visto a  $\approx 1500 \text{ kg/h}$ .

La relación de velocidad de una caja a otra es fija, y se modifica gradualmente la velocidad del conjunto accionando sobre el control de un tablero ubicado cerca del operario colador.

De tal modo resulta posible sincronizar la velocidad del laminador con la rueda de colada.

Como elementos complementarios del laminador merecen citarse:

#### \* Horquilla contrapeso

Consiste en un juego de 2 rodillos contrapesados que se deslizan en forma vertical en una columna ubicada a distancia intermedia entre la rueda y el laminador.

Su misión es la de permitir la formación de un bucle en la barra, lo que facilita la sincronización gradual de las velocidades del conjunto rueda-laminador.

Como se verá luego, las variaciones de velocidad obedecen primeramente a la puesta en marcha y luego, al hecho de obtener obligatoriamente un determinado valor de resistencia a la tracción sobre el alambrón a 9,5 mm (en el caso del aluminio-acero) que permita luego del trefilado a diferentes diámetros finales del alambre de aluminio, mantener las características mecánicas dentro de los valores exigidos por las normas.

Tales variaciones resultan además función de las temperaturas del metal, en la rueda y durante su paso a través de las 8 cajas de cilindros del laminador.

A continuación de la horquilla contrapeso se ha ubicado una guillotina neumática que permite efectuar en forma rápida el corte o despunte de la barra antes de proceder a la introducción en los rodillos guía situados a la entrada de la 1a. caja del laminador.

\* Trompa de salida y envolvedor

Inmediatamente a la salida de la última caja y sobre la pared posterior del laminador se ha colocado en nuestro caso un caño de latón en forma de S ( $\varnothing$  50 mm - largo 9 mts), también contrapesado cuya misión es la de dirigir el alambrón que sale a 120 mts/min, con una temperatura comprendida entre 200 y 280°C, según los casos, hacia el envolvedor.

Este está constituido por un tonel formado por varios listones de madera dura dispuestos en forma circular y unidos entre sí por medio de 2 anillos exteriores de hierro, y se halla colocado sobre un chasis cuadrado montado sobre 4 ruedas locas.

El conjunto envolvedor-chasis se coloca inmediatamente debajo de la trompa de salida del laminador. Al iniciar la colada, el primer extremo del alambrón se dirige rápidamente hacia el borde interior del envolvedor produciéndose automáticamente el enrollado del alambrón sobre sí mismo.

El contrapeso situado en la zona media de la trompa facilita el fácil manejo de un extremo posterior, el que es acompañado por el operario a fin de obtener una bobina compacta cuyo peso total oscila en los 600 kg (≈ 12.000mts).

Mediante un segundo envolvedor colocado igualmente sobre un chasis con cuatro ruedas locas, se desplaza, en el momento oportuno, el envolvedor lleno reemplazándolo por el vacío acompañado con un golpe de mano enguantada, el alambrón hacia este último. Luego se corta con una tijera al efecto el tramo de alambrón que une ambos envolvedores, se retira del chasis el esqueleto del envolvedor lleno por medio de un pequeño guinche y se extrae la bobina con la ayuda de un tow-motor que la conduce hasta la balanza y posterior al stock.

\* Circuito de lubricación - refrigeración

El laminador SPIDEM dadas sus características particulares está equipado con un circuito de lubricación-refrigeración atento a la misión que debe cumplir el aceite de laminado que se utiliza.

Además se cuenta con un circuito de lubricación de cojinetes y mecanismos que si bien cumple una misión importante no incide sobre las características del metal a obtener.

Por el contrario, el aceite de laminado reviste una función fundamental al actuar en 2 sentidos:

1. Como lubricante propiamente dicho, evitando el "pegado" del metal al cilindro durante el laminado de la barra. Es sabido que una lubri



cación deficiente trae como consecuencia un fenómeno de adherencia o pegado de metal a los cilindros de laminado, metal que vuelve a depositarse luego sobre el mismo alambrón produciéndose sobre la superficie de éste el defecto denominado "escamas" o "pajuelas" sumamente perjudicial en las etapas posteriores y al estado final dado que resulta prácticamente imposible eliminarlo afectando no sólo el estado de superficie del alambre terminado sino también su conductividad eléctrica.

En nuestro caso se utiliza un aceite soluble de importación en una concentración que se verifica antes y durante cada colada y que debe mantenerse lo más próxima posible al 20 0/00.

2. Como refrigerante, al ser proyectado a una cierta presión, caudal y temperatura sobre los cilindros durante el laminado. La regulación adecuada de las 3 variables, que está a su vez ligada a la temperatura de la barra y a la velocidad del laminador permite aplicar una velocidad de enfriamiento, que resulta función de las 5 variables mencionadas, y cuya consecuencia se traduce en un determinado valor de  $R_t$  a obtener sobre el alambrón laminado. Este valor de  $R_t$  para una composición química determinada, es entonces función del grado de deformación en frío aplicada. A los efectos de regular más fácilmente la velocidad de enfriamiento, cada caja de cilindros ofrece la posibilidad de modificar inmediatamente el caudal de lubricante por medio de un robinete. La capacidad de la cuba de aceite soluble, siendo del orden de los 1500 lts asegura un caudal constante de aceite, el que a su vez debe ser mantenido a una temperatura lo más constante posible ( $\pm 50^\circ\text{C}$ ) según se trate de A5C ( $500^\circ\text{C}$ ) o Almelec ( $600^\circ\text{C}$ ). El aceite es reciclado por medio de bombas que lo dirigen desde la cuba hacia los picos situados frente a c/caja de cilindros. De allí, pasa a un colector ubicado en el piso del laminador que lo conduce nuevamente a la cuba pasando previamente por un filtro de papel especial que retiene las virutas de aluminio y las impurezas que recoge durante el laminado. A fin de regular la temperatura se dispone de un tanque intermedio con termostato que permite calentar o enfriar el aceite, según las necesidades, por medio de una serie de resistencias eléctricas y una serpentina donde circula agua fría respectivamente. La presión del aceite en trabajo es de  $\approx 0,5$  a  $0,8 \text{ kg/cm}^2$ . El consumo por tonelada laminada es del orden de 2,5 lts/Tn incluyendo las pérdidas por evaporación.

El equipo obrero afectado al funcionamiento del conjunto Horno de colada-rueda-laminador, está constituido por 3 obreros bajo la responsabilidad del operario colador quien, en acuerdo con el capataz de la sección, modifica las velocidades del conjunto según las necesidades. Los 2 obreros restantes una vez puesta en marcha la colada atienden la operación de enrollado y evacuación de las bobinas.

El control de las características mecánicas de c/rollo en el caso del A5C es efectuado por un agente del Servicio de Control asistido por el mismo capataz de la sección.

### TREFILADO

La fabricación de cables alu-acero y de almelec presentan en común la utilización de una moderna máquina trefiladora de 9 trefilas fabricada por OTT (Office Technique des Tréfilés).

En el caso particular del almelec se utiliza una trefiladora Robertson adicional para efectuar el primer desgrosado exigido por razones metalúrgicas que imponen un temple y madurado a un diámetro intermedio, que corresponde dentro de ciertos límites a dos veces y media el diámetro final del alambre a cablear.

Para el alambre de aluminio se procede en una sola etapa sobre la trefiladora OTT. La bobina proveniente del laminador SPIDEM, previamente enfriada al aire, es colocada en el costado de entrada de la OTT y enhebrada a través de las trefilas de la misma.

La elección de estas últimas está en función del diámetro final a obtener dado que el diámetro inicial (9,5mm para Alu y 6,25mm para Almelec) se mantiene sensiblemente constante.

Al igual que en las cajas de cilindros del laminador Spidem, la trefiladora OTT permite la regulación de la velocidad de trefilado en forma individual para cada trafila por medio de un tambor envolvedor de arrastre, refrigerado interiormente por circulación de agua facilitando de tal modo:

- a) el sincronizado de la marcha en conjunto
- b) el enfriamiento del metal en curso de transformación
- c) el trefilado sin deslizamiento relativo entre el alambre y el tambor de arrastre

Teniendo en cuenta que el diámetro final del alambre puede oscilar entre ámbitos relativamente importantes (4,86mm a 1,90mm en nuestro caso), la elección de las trafilas se hace buscando aplicar una reducción por sección, que generalmente resulta del orden del 30% promedio, para cada pasada.

Antes de completar el trefilado de la 1a. bobina se procede a soldar a tope, mediante una sencilla operación con pasaje de corriente eléctrica, el extremo final de esa bobina con el inicial de la siguiente. Ello asegura una continuidad de fabricación que permite alcanzar una producción horaria de 100 a 900 kg/h en función del diámetro de salida.

A la salida de la trefiladora el alambre es enrollado en bobinas de 40 a 50 kg de capacidad que son utilizadas posteriormente en la operación de cableado.

El manejo, carga y descarga de la trefiladora OTT queda a cargo de un solo operario, quien a su vez es responsable de la identificación del material y de efectuar las anotaciones correspondientes.

A título complementario podemos agregar que la Trefiladora OTT ha sido puesta en servicio a mediados de 1963 habiendo producido hasta el 31/8/64 aproximadamente 1000 Tn de alambres de distintos tipos, para usos diversos.

Como instalaciones complementarias de la operación de trefilado pueden mencionarse además de la trefiladora Robertson, los siguientes hornos de tratamiento térmico, utilizados únicamente en la fabricación de Cables Almelec.

#### \* Horno CL

Fabricado por la firma Gauschi, de Suiza, específicamente para el templeado y envejecido de productos extrudados (perfiles, barras, etc.) ha sido puesto a punto con éxito para el templeado y madurado de rollos de alambre de almelec de diámetro 6,25 mm - de ~ 250 kg c/u.

#### Templado

Esta operación, para ser efectiva requiere un tiempo de maniobra corto para asegurar el solubilizado del siliciuro de magnesio previamente puesto en solución mediante un mantenimiento mínimo de 20 minutos a 560°C, seguido de un enfriamiento brusco en agua a temperatura ambiente.

La calefacción del horno está asegurada por dos quemadores a gas de 40 m<sup>3</sup>/h de caudal c/u, colocados simétricamente en los extremos opuestos del horno cuyas dimensiones útiles aproximadas son: largo 7 mts, ancho 1 mt y alto 1,3 mts.

La carga total de los rollos, del orden de 2,5 Tn - 10 rollos - se coloca previamente en un bote (construido en caños de hierro) que es introducido y sacado del horno con ayuda del puente grúa de la sección.

Para la operación de temple se dispone de una cuba con agua fría en circulación cuyo volumen útil alcanza aproximadamente a 15000 litros.

Al igual que los restantes hornos a gas, el CL está equipado con un seguro sistema de alarma que corta automáticamente la llegada de gas a los quemadores en el caso de producirse una anomalía en el funcionamiento del mismo.

El manejo es sumamente sencillo y el control y regulación de temperatura se efectúan por medio de 2 pirómetros ubicados convenientemente.

Un registrador MECI permite obtener en cada instante un gráfico

de la temperatura del interior del horno, que es sensiblemente regular y constante en todos los puntos del mismo.

Ello resulta particularmente importante para no "quemar" metal por un sobrecalentamiento, asegurando por otra parte la puesta en solución cuantitativa del Si Mg 2 íntimamente ligada a la temperatura crítica del temple.

### Madurado

En el mismo horno CL se efectúa el tratamiento complementario de madurado artificial (10 hs a 100°C).

El objeto de este tratamiento particular, al acelerar el madurado natural que se efectúa a temperatura ambiente durante algunos días, es el de obtener además una repartición más homogénea de los constituyentes precipitados, lo que garantiza una mayor regularidad en las características mecánicas a obtener al estado final.

La misma carga de la operación anterior (templado) vuelve a ser introducida en el horno durante 10 hs a  $100^{\circ}\text{C} \pm 5^{\circ}\text{C}$  para producir la precipitación del Si Mg 2 previamente solubilizado.

La fácil regulación del horno, su buena inercia térmica y la gran estabilidad y regularidad de temperatura en toda la superficie del horno permiten efectuar los tratamientos de templado y madurado artificial sin inconvenientes.

La producción horaria para ambos tratamientos es del orden de 250 kg/h.

### \* Horno SL

Al igual que el CL se lo utiliza únicamente en el proceso de fabricación del cable almelec.

Las características de este tipo de horno, tales como

- Calefacción por tubos radiantes sobre las paredes laterales
- Fácil regulación de marcha
- Estabilidad y repartición homogénea de la temperatura interior

lo hacen perfectamente adaptable para el tratamiento de revenido final del alambre.

La finalidad de este tratamiento de 12 a 15 hs a  $160^{\circ}\text{C} \pm 5^{\circ}\text{C}$  es la de completar la eliminación del Si Mg de la solución sólida, disminuyendo de tal modo la resistividad por debajo de  $3,25 \mu \Omega \text{ cm}^2$ , y actual además sobre las características mecánicas, en particular el A%  $\geq 3$  manteniendo una  $R_t \geq 30 \text{ kg/mm}^2$ , valores todos ellos exigidos por las Normas Internacionales de Cables Conductores.

La producción horaria oscila en los 150-200 kg/h para cargas de  $\approx 2 \text{ Tn}$ .

CABLEADO

CAMEA S.A. cuenta en su planta de fabricación de cables con dos máquinas cableadoras que ofrecen la posibilidad de fabricar cables con o sin alma de acero, protegida o no esta última y con una cantidad de alambres o hilos que abarca la gama comprendida entre 3 y 127 hilos.

En los cuadros que figuran en anexo se consignan las características de los cables fabricados hasta el momento sobre pedido de clientes.

En las fichas técnicas correspondientes se acompañan las características de cada cableadora con indicación de la capacidad de producción promedio en función del diámetro de los alambres a cablear.

Ambas cableadoras CB 1 y CB 2 son atendidas por un operario responsable y un ayudante.

La velocidad de cableado puede oscilar entre 10 y 50 mts/min.

Teniendo en cuenta que nuestras cableadoras no difieren de lo tradicional en este tipo de máquinas, no nos extenderemos sobre el tema.

Digamos solamente que la producción de cables Alu-Acero y Almelec al 31/8/64 en función de la demanda, ha sido la siguiente:

	Km	Tn
Aluminio-Acero	1.814,7	354,5
Almelec	<u>1.231,7</u>	<u>301,0</u>
Total	3.046,4	655,5

La capacidad de producción actual de la Sección Cableado puede sobrepasar las 150 Tn/mensuales según el tipo de cable a fabricar.

CONSIDERACIONES METALURGICAS

Aún teniendo en cuenta que el objeto de este trabajo es puramente tecnológico estimamos necesario efectuar algunas consideraciones de orden metalúrgico dado que se imponen al proceso de fabricación ciertas limitaciones a respetar y cuya justificación, como es lógico resulta evidente.

Según normas internacionales se exige a la vez, para un mismo diámetro de alambre, un valor mínimo de carga de rotura, una resistividad máxima y una capacidad de deformación caracterizada, ya sea por el porcentaje de alargamiento o por el número de plegados sobre si mismo.

Se ha constatado que tales características están íntimamente ligadas a la composición química, a las condiciones de colada y laminado y al grado de deformación en frío aplicado. Por ej.: para una misma composición química, lo que incide favorablemente sobre la conductividad, actúa en forma contraria sobre las características mecánicas y vice-versa.

El estudio de las siguientes variables, efectuado por varios investigadores, ha permitido observar su influencia y resolver la cuestión.

## 1. Composición Química

### a) Caso del Aluminio Conductor (A5C)

Inciden en forma importante el tenor de impurezas presentes, destacándose algunas de ellas como muy nocivas aún en valores bajos, tales como el Ti ( $\leq 0,004\%$ ) y el Vanadio ( $\leq 0,001\%$ ).

El gráfico en anexo muestra la influencia de cada impureza sobre la resistividad del alambre a un mismo diámetro final - es decir idénticas condiciones de transformación.

Se destaca netamente que impurezas tales como el V Ti y Mn son altamente perjudiciales en tenores aún inferiores a 0,01.

Las 2 primeras (V y Ti) son eliminadas mediante un tratamiento con un flux especial que favorece la formación de compuestos que se eliminan parcialmente quedando el resto bajo forma de constituyentes fuera de la solución sólida que por lo tanto no perturban la transmisión de corriente eléctrica. El tenor residual después del tratamiento es del orden de V  $\leq 0,001\%$  y Ti  $\leq 0,004$ . Es de destacar que el V se encuentra a menudo en tenores prácticamente despreciables, aún antes del tratamiento al flux y el Mn no excede habitualmente los límites perjudiciales.

Los gráficos de dispersión que figuran en anexo muestran los valores de los productos CAMEA S. A. - que se hallan encuadrados dentro de las siguientes tolerancias fijadas para esta fabricación

Cu	Mg	Mn	Fe	Si	Ti	Zn
$\leq 0,008$	$\leq 0,008$	$\leq 0,006$	$0,20 \pm 0,02$	$0,07 \pm 0,01$	$\leq 0,004$	-

Digamos al pasar que el control de composición química se efectúa obligatoriamente (al igual de Rt y A%) a diámetro 9,5 durante la colada y laminado de cada rollo.

CAMEA S. A. posee un espectrolector CAMECA de lectura directa que permite conocer la composición química (7 elementos) de un material en menos de 5 minutos transcurridos entre la extracción de la probeta -en el tanque intermedio de la rueda de colada y la expresión de los resultados obtenidos sobre el espectrolector.

Con los valores indicados y una Rt  $\geq 17$  kg/mm<sup>2</sup>, se está en condiciones de garantizar una  $\rho \leq 2,8264 \mu\Omega \text{ cm}^2 \cdot \text{cm}$  (CEI).

b) Caso del Almelec

Al igual que para el A5C, los valores del gráfico de dispersión se hallan comprendidos dentro de los siguientes límites, fijados como máximos para garantizar una Rt  $\geq 33$  kg/mm<sup>2</sup> y una  $\rho \leq 3,28 \mu\Omega \text{ cm}^2 \cdot \text{cm}$  exigidas por las Normas Internacionales.

Cu	Mg	Mn	Fe	Si	Ti	Zn
$\leq 0,008$	$0,7 \pm 0,1$	$\leq 0,006$	$0,2 - 0,3$	$0,5 - 0,7$	$\leq 0,004$	-

2. Condiciones de Colada y Laminado

a) Caso del Aluminio Conductor A5C

Investigaciones anteriores han puesto en evidencia que las condiciones de colada, en particular la velocidad de enfriamiento, ejercían una influencia importante sobre la conductividad cuando se mantienen constantes las restantes variables.

Comparativamente con alambres obtenidos por el sistema clásico de prensado (o laminado) y trefilado, el alambre fabricado por el sistema PROPERZI presenta un valor de resistividad mayor. Además se constató que la repartición de constituyentes era mucho más fina en el proceso clásico que en el PROPERZI.

Varias explicaciones han sido dadas por diferentes autores. A continuación se resume la enunciada por el Ing. CHEVIGNY - Jefe del Servicio de Investigaciones de PECHINEY en Chambéry:

"Tanto en los barrotes cuadrados (sección 10.000 mm<sup>2</sup>) como en la barra SPIDEM (sección 1.000 mm<sup>2</sup>) la velocidad de solidificación

sería tal que determinaría segregaciones menores de las impurezas principales Fe y Si. Estas constituirían en la proximidad de los límites de las dendritas, zonas de baja conductividad, aislando en mayor o menor grado las dendritas entre sí.

En el caso de los barrotos cuadrados, varios factores favorecerían su destrucción, al menos parcial, tales como el precalentamiento a 450-500°C previo al laminado que favorecería la difusión de las impurezas y produciría un cierto efecto de homogeneizado, y además el % de deformación elevado - correspondiente a la transformación de una sección de 10.000 mm<sup>2</sup> dispersaría suficientemente las segregaciones para que éstas no tuvieran efecto importante sobre la conductividad.

Por el contrario, en la barra Properzi, el efecto de homogeneización no tendría tiempo de manifestarse dada la sucesión rápida de las operaciones. Además el grado de deformación, mucho menor que para los barrotos cuadrados no conduciría a una dispersión muy profunda. Con respecto a este último, un aumento en la sección de la barra Properzi, cuya consecuencia es un aumento del % de reducción posterior, mejora sensiblemente la conductividad del alambre. Por otra parte, un homogeneizado de los barrotos a 500°C mejora sensiblemente la conductividad, pero por razones obvias no se trata de efectuar un homogeneizado de la barra Properzi".

El problema fue resuelto prestando atención a las condiciones de colada y laminado y respetando las limitaciones en cuanto a composición química se refiere.

Se destaca que un recocido intermedio del alambrón mejora, para una misma composición química, la conductividad del alambre a diámetro final.

Resulta necesario destacar además que regulando convenientemente las condiciones de colada y laminado, se ha logrado evitar el recocido intermedio del alambrón pudiendo obtenerse no obstante las características mecánicas y eléctricas exigidas, como lo muestran los valores que figuran en el anexo.

Teniendo en cuenta que el diámetro de salida del alambrón se mantiene constante a 9,5 mm y que el diámetro final puede variar dentro de ámbitos importantes se debe prever una marcha del conjunto rueda-laminador tal que, a cada diámetro final corresponda una Rt a  $\phi$  9,5 que permita la transformación en frío necesaria para alcanzar la Rt final sin excederse dado que a una mayor Rt corresponde consecuentemente una mayor resistencia.

Mediante el cálculo teórico y la confirmación práctica se han logrado establecer los límites de Rt a  $\phi$  9,5 mm en cada caso particular, los que



son controlados obligatoriamente al comienzo de cada rollo en curso de fabricación por medio de una máquina de tracción Amsler de 2 Tn -en nuestro caso- colocada a la salida de la trompa del laminador.

b) Caso del Almelec

Dado que esta fabricación contempla un tratamiento de temple y ma-durado a aproximadamente dos veces y media el diámetro final, la marcha del conjunto rueda-laminador se rige por la necesidad de obtener una barra sana pues como ya hemos dicho anteriormente, las aleaciones al silicio de magnesio presentan, comparativamente con el aluminio, una mayor tenden-cia a fisurarse en caliente.

Analizadas las dos variables fundamentales sólo resta indicar que la última de ellas, la resistividad es función de aquellas.

En el caso particular del almelec no debe olvidarse que las caracterís-ticas mecánicas y eléctricas se obtienen por medio de un tratamiento térmico de revenido. Ello significa un control delicado de la evolución de tales características en curso de tratamiento para asegurar una calidad dentro de normas.

Un sencillo procedimiento mediante el empleo de "probetas piloto" nos ha permitido solucionar el problema satisfactoriamente.

CONCLUSION

Con el presente trabajo no pretendemos haber efectuado un nuevo aporte al campo de la Metalurgia de transformación del aluminio y de la aleación aluminio-silicio de magnesio destinados a la fabricación de cables conductores.

Nos hemos limitado solamente a exponer los métodos de fabricación empleados por una empresa local, con garantía de la calidad obtenida, comparable con la del material de importación.

El proceso enunciado no pretende ser exclusivo ni mucho menos, sólo aspira a poner en evidencia el nivel alcanzado en este Campo de la Metalurgia de Transformación en nuestro país. Ello ha sido posible merced a la gran facilidad del operario argentino para adaptarse a nuevas tareas y el sentido de responsabilidad que puede evidenciar cuando le es requerida su colaboración.

El actual déficit energético del país permite suponer un desarrollo de meru-

cado relativamente importante a corto plazo si se tiene en cuenta que es el Estado el cliente de mayor importancia a través de sus organismos especializados.

Es de destacar que se ha observado una marcada tendencia hacia la utilización del almelec, hecho que por otra parte se produce también en otros países del viejo y nuevo mundo, lo que ha permitido intensificar los esfuerzos en ese sentido.

Actualmente puede considerarse que CAMEA S. A. absorbe la mayor parte del consumo local y además fabrica cables para la exportación a países latinoamericanos tales como Brasil y Chile, que se hallan también abocados a la solución de su déficit energético.

Desde el punto de vista metalúrgico digamos que la colada continua y laminado simultáneo de la barra por el sistema Properzi es una solución elegante al problema de la fabricación de alambres de aluminio o almelec destinados no solamente a la fabricación de cables sino también a otros usos diversos.

Con relación al proceso clásico de fabricación de alambres por prensado (o laminado) del barrote y posterior trefilado, presenta una serie de ventajas entre las que merecen destacarse, además de la calidad y regularidad del producto terminado, un importante aumento de la productividad dado que disminuye considerablemente los costos por reducción del personal afectado y permite la utilización de bobinas más pesadas, lo que simplifica los inconvenientes de manutención, de almacenamiento y de transporte. La supresión casi total de las soldaduras es particularmente apreciada en el caso del almelec. No obstante, se trata de una fabricación que si bien requiere una mano de obra reducida obliga a una vigilancia y control técnico bastante severo para mantener el alto nivel de calidad exigido por la clientela. Las 700 Tn fabricadas dan una prueba de ello.

Por último, no queremos finalizar nuestra exposición sin hacer público nuestro agradecimiento al Directorio de CAMEA S. A. por haber permitido su divulgación y a todo el personal que ha colaborado en la recopilación y preparación de este trabajo.

BIBLIOGRAFIA

F.R. Nichols - Wire and Wire Products 1953 (28) - 1185

U. Lecis y B. Penbianco - Congreso Internacional del Aluminio - París 1954 - II -  
151

A. Crevet y J. C. Beguin - Rev. Aluminium 1958 (256) 751

J. Russell y F.R. Nichols - Inst of Metals 1959 - 209

P. Barand y R. Gadeau - Aluminio - Enciclopedia PECHINEY Eyrolles - Paris  
1964 - Tomos I y II

ESTUDIO DE LA COLAMINACION DE METALES

por J. Almagro, G. Cusminsky y C. Martínez Vidal

1. INTRODUCCION

Desde el punto de vista metalúrgico existen dos métodos básicos para unir metales. El primero consiste en obtener por fusión esa unión ya sea del mismo metal base (soldadura por fusión), o de otro metal, o aleación de menor punto de fusión ("brazing"). Por el segundo método, se obtiene esa unión en estado sólido.

Esta unión en estado sólido toma diferentes nombres en la literatura, según el proceso seguido: unión por difusión, unión por presión hidrostática, unión por indentación, unión por colaminación, etc. Podemos no obstante ordenarla y dividirla en dos grandes grupos:

- a) unión en frío: cuando la temperatura de trabajo está por debajo de la llamada temperatura de recuperación. En este caso actuaría sólo la presión.
- b) unión en caliente: cuando la temperatura de trabajo es mayor que la de recristalización. Aquí además de la presión, actúan la temperatura y el tiempo.

En la actualidad se obtienen industrialmente por estas técnicas, una variedad de materiales compuestos, que permiten aunar y aprovechar al máximo diferentes propiedades de distintos metales, con la consiguiente reducción de costos.

Si bien estos procesos entraron en su etapa industrial alrededor de 1935 y en la actualidad están bien definidos empíricamente, los mecanismos que operan en la unión no están suficientemente aclarados y varios investigadores postulan su dependencia de diferentes y contradictorios factores.

La necesidad de construir en la Comisión Nacional de Energía Atómica los elementos combustibles tipo MTR para un reactor de 5 MW, hizo que se pensara en estos métodos de unión, desarrollando las técnicas correspondientes. Para ello se eligió la colaminación, proceso en el que la presión está dada por la reducción obtenida al pasar el material entre los cilindros de una laminadora.

De esta manera se obtendría la estanqueidad y condiciones de transferencia térmica necesarias. El método consiste de cerrar totalmente el núcleo fisionable de aleación aluminio-uranio; lateralmente por un marco de aluminio, y las superficies con dos tapas de aluminio, que se colaminan con el marco y el núcleo (1).

## 2. COLAMINACION

### 2.1. Trabajos previos

En 1944 Kinzel (2) da un enfoque teórico al problema, atribuyendo las causas de la unión a la difusión. En 1956 Durst (3) atribuye las causas de unión a la aproximación de las superficies a distancias interatómicas obteniéndose fuerzas de atracción superiores a las de repulsión producidas por las fuerzas de recuperación elásticas.

Parks (4), Hoffmann y Ruge (5), Williams y Bever (6), Erdman-Jesnitzer (7), etc., efectúan trabajos sobre colaminación sin agregar nuevos conceptos a los anteriores.

En 1959 Milner comienza con sus colaboradores una sistemática que dura hasta 1962 y condensa la información en un "Review Paper" (8). Postula, al igual que Durst, que la unión se debe a la aproximación de las dos superficies, hasta llegar a distancias atómicas.

### 2.2. Parámetros analizados

Al iniciar el trabajo se tuvieron presentes dos objetivos:

- I) La determinación de las condiciones óptimas para obtener la colaminación en el problema concreto de elementos combustibles.
- II) Procurar aclarar o entender los mecanismos que operan en ese proceso.

Nos limitaremos al punto II, indicando el estado actual de los trabajos (9-10).

Al estudiar los parámetros que se suponía tenían influencia en la unión por colaminación, se les agrupó en:

- a) Condiciones de superficie en el material a unir, y
- b) Condiciones de laminación (proceso empleado).

En las condiciones de superficie enumeraremos:

- a<sub>1</sub> Contaminación superficial: i) oxidación  
ii) adsorción y absorción de otros gases
- a<sub>2</sub> Endurecimiento por deformaciones previas
- a<sub>3</sub> Rugosidad
- a<sub>4</sub> Energía almacenada

Para las condiciones de laminación se consideraron:

- b<sub>1</sub> Deformación, dada por la reducción en una pasada
- b<sub>2</sub> Presión específica media de laminación
- b<sub>3</sub> Velocidad de deformación
- b<sub>4</sub> Relación de potencia
- b<sub>5</sub> Temperatura de trabajo
- b<sub>6</sub> Aumento de temperatura por deformación

### 2.3. Equipos y material usados

Se utilizaron dos laminadoras, una de alta precisión para reducciones medias (Fig. 1), y otra de desbaste para grandes reducciones. Se medía presiones con celdas de carga hechas con "strain gages" y se registraban, como muestra la Fig. 1, además los equipos accesorios necesarios: microscopios, máquinas de ensayos, etc. El material utilizado fue aluminio de pureza comercial tipo 1100, analizado espectrográficamente en cada caso y con distintos grados de endurecimiento.

### 2.4. Método de trabajo

Se efectuaba la preparación superficial de las probetas. Se colaminaba con distintas reducciones y se cortaban probetas para ensayos mecánicos y metalografía. La Fig. 2 indica las entalladuras efectuadas para el ensayo tracción-corte y una probeta ya ensayada.

Cabe hacer notar la dificultad en la preparación de las probetas de tracción-corte, que recién dieron resultados satisfactorios a los seis meses de iniciado el trabajo.

### 3. RESULTADOS OBTENIDOS Y DISCUSION

#### 3.1. Colaminación en frío

##### a) Condiciones de superficie

Es bastante difícil, en un material como el aluminio, la separación de los distintos parámetros, pues ellos interactúan y forman parte de un todo que hemos llamado "preparación superficial". Todas las probetas fueron desengrasadas en vapores de tricloroetileno, decapadas en baño alcalino y posteriormente en ácido y secada con lámparas infrarrojas.

- a<sub>i</sub>) Oxidación: Se tomaron probetas pulidas y cepilladas, oxidándolas a distintas temperaturas y tiempos colaminándolas posteriormente. Las probetas pulidas colaminaron entre 26 y 30%, las cepilladas entre 40 y 45%.
- a<sub>ii</sub>) Se cepillaron y se dejaron tiempos variables en aire, con distinta humedad ambiente. Se observó que para tenores crecientes de humedad ambiente disminuía el tiempo en que se podría exponer la probeta luego de cepillada y antes de colaminar.
- a<sub>iii</sub>) Se cepillaron y se sellaron (evitando la posibilidad de contaminación en el aire) dejándose tiempos variables antes de colaminar. Se obtuvo una excelente unión incluso dos horas después del sellado.
- a<sub>c</sub>) Endurecimiento por deformaciones previas: Se observa un aumento en la deformación mínima de colaminación y un apreciable aumento en la resistencia, en oposición a otros resultados. La Fig. 3 muestra estos resultados.
- a<sub>g</sub>) Rugosidad: Luego de distintas tentativas, se determinó que el aumento de rugosidad es perjudicial si las probetas son posteriormente oxidadas.  
Con probetas cepilladas se observó metalográficamente en la interfase las lunas cuya microdureza es aproximadamente doble que la del material adyacente como se puede apreciar en la Fig. 4.
- a<sub>4</sub>) Lo complejo de su estudio, hizo que en esta primera fase se descartara.

##### b) Condiciones de laminación

- b<sub>1</sub>) Se determinó para las distintas preparaciones superficiales

ya enunciadas, la deformación mínima necesaria de colaminación. Se trazaron las curvas de resistencia de unión en función de la deformación. Fig. 3.

- b<sub>2</sub>) Para algunas condiciones se midió la fuerza separadora y se determinó la presión específica media de laminación. Se trazaron curvas en función de la deformación. Fig. 5.
- b<sub>3</sub>) Calculada la máxima variación de la velocidad de deformación se obtuvo entre 350%/seg a 450%/seg, lo que hace que se pueda suponer constante este parámetro.
- b<sub>4</sub>) La relación de potencia, altura inicial del material dividida por el diámetro del rodillo, se mantuvo constante en 4.75% en las dos laminadoras.
- b<sub>5</sub>) La temperatura de trabajo era la ambiente.
- b<sub>6</sub>) Según fórmula empírica de Siebel, se apreció que no era muy grande el aumento de temperatura por trabajado. Este parámetro se tuvo en cuenta para asegurar que no entráramos a temperaturas de recuperación.

## .2. Colaminación en caliente

### a) Condiciones de superficie

Desaparece el efecto del endurecimiento previo y de la energía almacenada. Se trabajó entre 550° y 600°C. Las probetas fueron desengrasadas y decapadas y secadas.

Se determinó que, para los tiempos de calentamiento necesarios (del orden de 30 minutos) la rugosidad resultaba perjudicial, obteniéndose uniones más limpias y con menor deformación mínima de colaminación, para probetas pulidas químicamente. La oxidación se estudió dejando tiempos crecientes en el horno. La deformación mínima de colaminación era de 7% para 30 min. a 600°C, y subía a 20% para 180 minutos a 600°C.

### b) Condiciones de laminación

En general puede decirse que continúan teniendo validez las de colaminación en frío.



#### 4. CONCLUSIONES

##### 4.1. Condiciones para obtener unión por colaminación

Del análisis de las condiciones de laminación surge claramente que, todos aquellos parámetros que de alguna manera aumentan la fuerza separadora y, por lo tanto, la presión específica media de laminación, incrementará la resistencia de la unión. Tal es el caso del endurecimiento por trabajado previo. Dicho en otras palabras, para incrementar la resistencia de la unión interesa la presión aplicada. Esto es válido para colaminación en frío y en caliente.

Las condiciones de superficie afectarían el umbral mínimo de unión. Al estudiar esas condiciones, ciertos parámetros tienden a disimular el efecto de otros, pero puede decirse en forma general que es fundamental eliminar la zona contaminada para obtener unión. En ambos casos de colaminación en caliente y en frío, es preferible la formación de óxidos frágiles, aunque sean de mayor espesor, que la de óxidos que sigan la deformación.

Pareciera claro que la unión se efectúa en la diferencia entre la zona deformada y la superficie inicial, que si el óxido es frágil se mantendría constante. Las figuras 6 y 7 muestran esto para deformaciones cercanas al umbral mínimo con diferentes aumentos.

El efecto de la rugosidad no pareciera claro, en la colaminación en frío. En caliente es evidentemente perjudicial por la gran oxidación que desarrolla.

##### 4.2. Dispersión de resultados

La bibliografía presenta una gran dispersión de resultados. No sería incorrecto suponer que ello se debe a dos factores:

- a) la dificultad para obtener ensayos mecánicos sencillos y reproducibles que midan la resistencia de unión de las probetas colaminadas
- b) la dificultad en asegurarse la eliminación total de la zona contaminada. Esto se obviaría efectuando la colaminación en alto vacío, pero no se tienen datos a la fecha.

##### 4.3. Temas en ejecución y a efectuarse

Se ha iniciado una sistemática tendencia a aclarar mejor el efecto de la rugosidad en la colaminación en frío.

Igualmente se trabaja en observar la distribución de óxidos para altas de-

formaciones procurando relacionar la superficie de unión con la resistencia de unión:

- a) Se considera interesante estudiar el efecto de la energía superficial almacenada sobre la unión.
- b) Estudiar en grandes cristales la facilidad de unión en función de las orientaciones relativas de las dos caras a unir.

#### BIBLIOGRAFIA

1. Fabrication of fuel elements for research reactors. Report P/837 3a. Conf. Int. sobre Utilización de la Energía Atómica con Fines Pacificos. Ginebra, 1964.
2. A. KINZEL. Welding J. 1944 (23) p.1124
3. G. DURST. J. of Metals 1956, p. 328
4. J. PARKS. Welding J. 1953 (32) p.209 S
5. W. HOFFMANN y J. RUGE. Z. Metallkunde 1952 (43), p.133
6. J. WILLIAMS y B. BEVER. A.S.M. preprint No. 175, 1959
7. F. ERDMANN-JESNITZER. Aluminium, 1957 (33), p. 730
8. D. MILNER y G. ROWE. Metallurgical Reviews 1962 (7), p.433
9. G. CUSMINSKY. Informe beca "Torcuato Di Tella", Soc. Científica Argentina, Bs. As., 1962
10. J. ALMAGRO y G. CUSMINSKY. Informe Facultad de Ciencias, La Plata, 1964



Figura 1 Laminadora, Equipo de Medición de Presiones y Sistema de Registro



Figura 2 Probeta Entallada, Dispuesta para el Ensayo y Probeta luego de éste Mostrando la Rotura sobre la Interfase

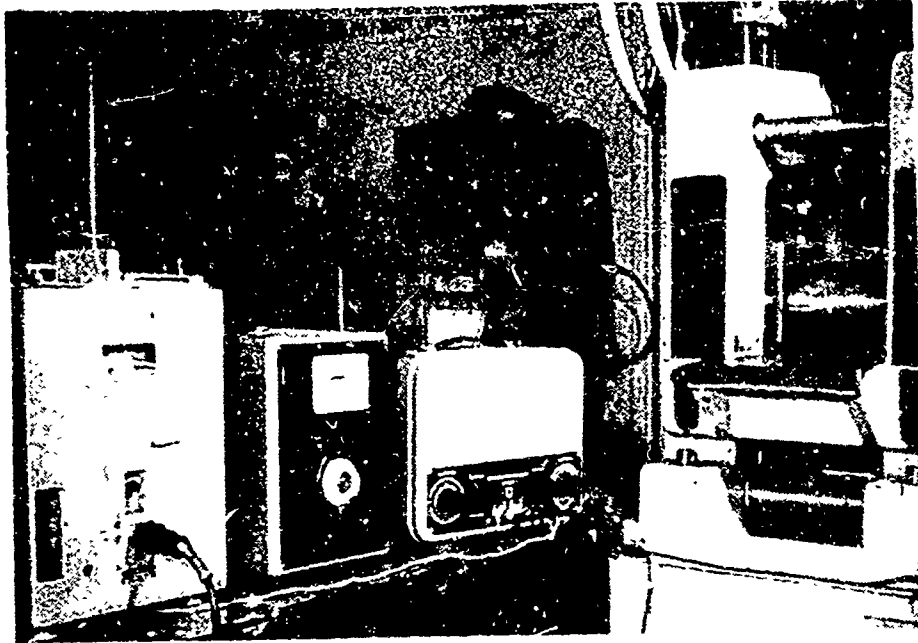

Figura 3 Resistencia de la Unión Colaminada

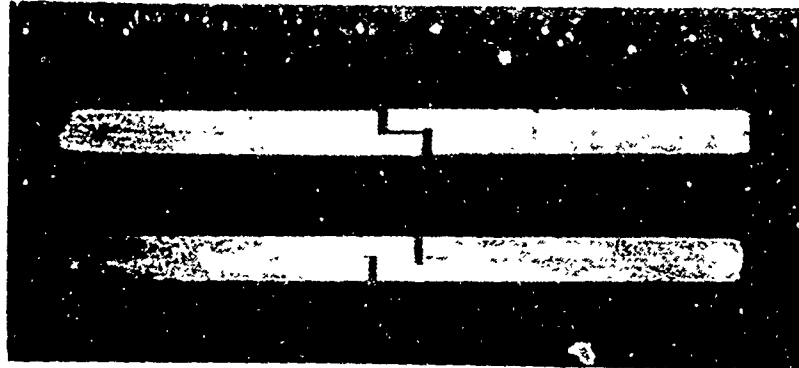

Figura 4 Impresiones de Microdureza en la Interfase de Al-Al Colaminado en Frfo 325 X

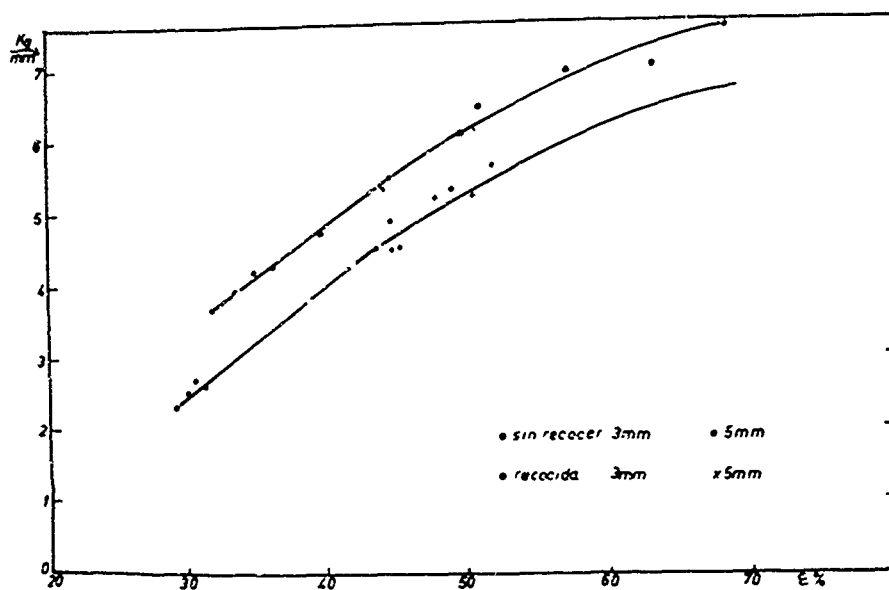

Figura 5 Presión Específica Media

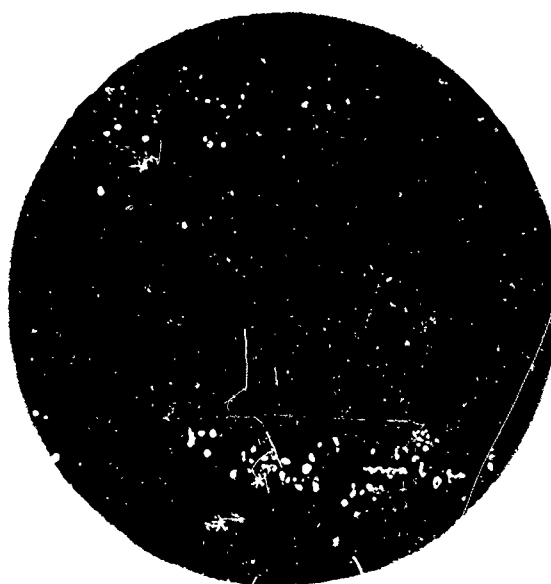

Figura 6 Micrografía de la Interfase de Unión para 30 seg. de Exposición al Aire. Ataque: Agua Regia Fluorada 80 X

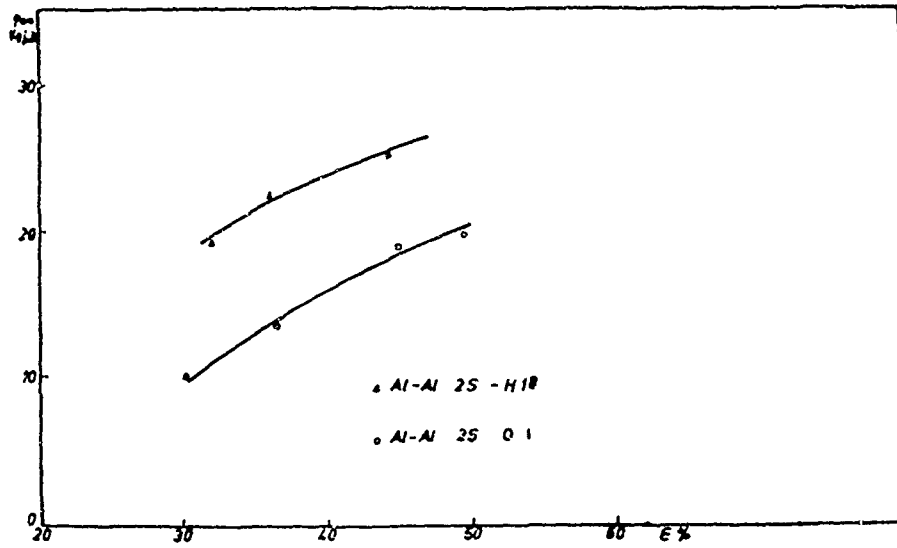

Figura 7 Micrografía de la Interfase de Unión presentando Lagunas Cerradas de Oxidos. Ataque: Reactivo de Milner 400 X

INFLUENCIA DEL EFECTO DE TAMAÑO Y ENTALLADURA  
EN LA RESISTENCIA A LA FATIGA DE ELEMENTOS ESTRUCTURALES  
Y DE MAQUINAS

por

Ing. Roberto Kuguel

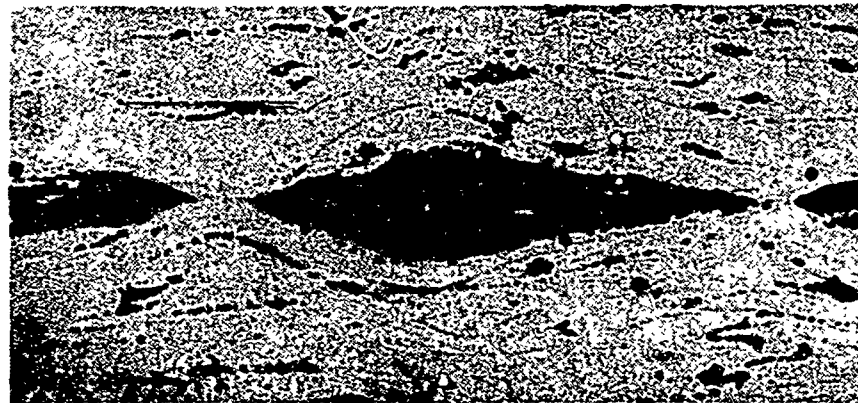
Introducción

Desde un punto de vista práctico, la resistencia a la fatiga, tal cual se determina en experiencias de laboratorio, es útil en la medida que sus resultados pueden ser trasladados de la pequeña probeta utilizada generalmente en el laboratorio, al tamaño real de la parte estructural en cuestión.

Para trasladar los valores de la resistencia a la fatiga de las pequeñas probetas de laboratorio a la pieza real, debe considerarse por lo menos la influencia de cuatro variables: la entalla, la variación de resistencia a la fatiga con el volumen (efecto de tamaño), la forma del elemento real, y la posible diferencia en la forma de aplicación de la carga.

En este estudio, se considerarán qué iguales condiciones tienen lugar en las probetas y elementos estructurales, con respecto a las otras variables.

Cada uno de los factores arriba mencionados han recibido la cuidadosa atención de muchos investigadores, que han tratado el problema desde algún punto de vista particular: la influencia de la entalla, la disminución de la resistencia a la fatiga con el diámetro, el comportamiento de diferentes conformaciones bajo cargas repetidas, etc. Desgraciadamente los resultados no fueron siempre concordantes, no habiendo sido posible compararlos debido a la ausencia de un factor común apropiado.

Propósitos y Alcance

El presente estudio trata de los diversos factores geométricos que intervienen en el problema del diseño bajo cargas repetidas en metales. esto es la entalla, los efectos de tamaño y forma, y la influencia de los diferentes tipos de cargas. Es su objeto encontrar una expresión simple suficientemente generalizable y

razonablemente segura, a fin de su inmediata aplicación al diseño.

Como parámetro o factor común, se investiga la influencia del volumen al tamente tensionado de material.

Aunque se delinea un procedimiento general, el alcance de este estudio con cierno primariamente a estado de flexión, debido a la falta de datos apropiados pa ra otros tipos de carga.

### Análisis

Es el propósito de este análisis, encontrar una expresión aplicable al problema de diseño bajo cargas repetidas. Trata de algunos de los factores que gobier nan la fractura por fatiga en probetas metálicas sometidas a momentos flexores o torsores.

### Gradiente de Tensión

La superficie, que es donde se inician con mayor frecuencia las fisuras, tienen una gran influencia en la rotura por fatiga; luego, su estado merece una cuidadosa atención en todo estudio dirigido al diseño.

Para un metal dado, puede definirse la superficie con el conocimiento de las siguientes variables: 1) ambiente, 2) rugosidad, 3) tensiones residuales, y 4) gradiente de tensiones. Se supondrán constantes los tres primeros y consideremos pues el gradiente de tensiones, definido como:

$$G = \frac{d \sigma_{\max}}{dy} \frac{1}{\sigma_{\max}} \left( \frac{1}{\text{cm}} \right) \quad (1)$$

Para probetas lisas, sometidas a flexión, el valor de G es inmediato:

$$G = 2/d \quad (2)$$

Para otros tipos de probetas, es posible derivar expresiones apropiadas, partiendo de las fórmulas de Neuber (ref. 1). Para probetas con entallas profundas sometidas a flexión o torsión, las derivaciones fueron dadas por Uzhik (ref. 2). En ref. 3 se dan ecuaciones aproximadas para computar G.

### Punto de Vista Estadístico

La falla por fatiga es un fenómeno estadístico. Está la rotura asociada con defectos en el seno del material: la probabilidad de encontrar un defecto es proporcional al volumen del mismo. Luego, la probabilidad de falla aumenta con el volumen de material. Este argumento es la base que permitió el desarrollo de diversas teorías estadísticas de fatiga (refs. 4 y 5).

### Volumen de Material Altamente Tensionado

Es posible combinar las premisas anteriormente expuestas, estableciendo consecuentemente que, dentro de un margen estadístico, dos probetas tendrán igual probabilidad de falla si ambas tienen el mismo volumen altamente tensionado. Por "volumen altamente tensionado" se entiende la delgada capa de material sometida a una tensión relativamente alta, por ejemplo 95% y más de  $\sigma_{max}$ . Cualquier región o porcentaje podría haberse elegido, siempre que el gradiente de tensión en la misma fuera aproximadamente lineal.

De ser cierta esa aseveración, la resistencia a la fatiga no dependería ya, entre otros factores, del diámetro de la probeta sino del volumen mencionado. Además, debe recalcar que un mismo valor de ese volumen puede alcanzarse en una probeta pequeña lisa, y en otra entallada, con mayores, apropiadas dimensiones.

### Efecto del Tamaño

La hipótesis será aplicada en primer término al efecto de tamaño, esto es la disminución de resistencia a la fatiga observada en piezas metálicas, cuando su tamaño aumenta. En primer término se trató de correlacionar el efecto de tamaño con la resistencia a la fatiga  $\sigma_f$  y la resistencia estática  $\sigma_u$ . Aunque sería dable esperar que los resultados en un diagrama  $\sigma_f$  vs  $\sigma_u$  se separaran en bandas que contendrían diferentes rangos de diámetro, ello no tuvo lugar.

Un segundo intento de correlación se efectuó entonces, ploteando el logaritmo del volumen altamente tensionado arriba mencionado versus logaritmo  $\sigma_{max}$ . Para ello se utilizaron resultados provenientes de trabajos de D. Morkovin y H. F. Moore (ref. 6), y H. F. Moore y T. J. Dolan (ref. 7).

El volumen altamente tensionado fue determinado tomando en cuenta el gradiente de tensión y las siguientes hipótesis simplificadoras (ver fig. 1 y ref. 8):

1. El área A será considerada triangular.
2. La distancia  $d'$  entre centros de gravedad de las áreas A es aproximadamente igual al diámetro d de la probeta.
3. El volumen V está sometido a un momento flexor puro.
4. El factor  $K_t$  no modifica su magnitud desde d a  $d_1$ .



Las hipótesis 3 y 4 dependen para su justificación de la distancia  $\Delta L$ , a cual en la gran mayoría de los casos es lo suficientemente pequeña para ello. Los resultados muestran (fig. 2) una relación pronunciadamente lineal (\*). La línea recta resultante puede ser representada por la ecuación:

$$\sigma_{\max} = B \cdot V^{-a} \quad (3)$$

A fin de hacer este procedimiento aplicable a problemas prácticos, esa recta fue dibujada a través de un valor experimental que tiene, en cada caso, el mismo volumen altamente tensionado:  $V_1 = 0.000349$  pulg<sup>3</sup>. Este volumen corresponde a una probeta lisa de  $d = 0.25$  pulg, y  $r = 1.25$  pulg. Luego, los parámetros de la ecuación (3) tendrán los siguientes valores:

$$B = 0.136 \sigma_{\max 1}$$

donde  $\sigma_{\max 1}$  es la tensión máxima para  $V_1$ , y

$$a = 0.034$$

En la fig. 2 están representadas estas rectas y las correspondientes a una banda de dispersión de  $\pm 10\%$ . Como puede observarse, todos los puntos yacen dentro de esas bandas, excepto dos.

#### Efecto de la Forma y del Tipo de Carga

El procedimiento anterior destinado a determinar el volumen de material altamente tensionado, no se ve restringido a la utilización de probetas con igual forma transversal o tipo de carga. Por ello, la técnica utilizada fue extendida a diversos casos seleccionados de las referencias 9 y 10.

La fig. 3 muestra el comportamiento de probetas de aleación de aluminio 24S-T en ensayos de flexión alternativa y rotativa, ref. 9. Como en este caso no hay probetas con el "volumen índice"  $V_1 = 0.000349$  pulg<sup>3</sup>, no es posible aplicar la ecuación (3). Sin embargo, se observa que las probetas siguen la tendencia general. También de la misma figura es posible observar que probetas con secciones transversales con esquinas agudas, tienen una definida reducción de resistencia, además del efecto de forma ya mencionado. En la figura anterior - número 2- se ha incluido también resultados para un acero SAE 4340, correspondientes a 4 diferentes formas de sección transversal, bajo flexión alternada. Estos resultados yacen dentro de la misma banda de dispersión determinada para el mismo acero, en ref. 7. No se han efectuado correcciones tendientes a considerar la pequeña diferencia de propiedades estáticas entre ambos aceros SAE 4340.

(\*) Como la mayoría de las probetas utilizadas en los estudios aquí detallados fueron construidas con la libra y pulgada como unidades de medida, se ha preferido seguir este sistema para desarrollar los resultados obtenidos.

## Ensayo Estático

Finalmente y escapando un poco del alcance establecido para este estudio, se da en la fig. 4 resultados de tensión de fluencia medida en ensayo estático: se da allí valores de la tensión de fluencia en función de  $\log. V$ , según resultados dados en ref. 11. Aquí también se observa una reducción lineal de la resistencia con  $V$ , aunque la inclinación resulta un poco mayor. No obstante, utilizando la misma pendiente que en los casos anteriores, la dispersión resulta ser menor del 20%.

Relación Entre  $K_t$  y  $K_f$ 

Es bien sabido que la mayoría de los metales no muestran una reducción de su resistencia a la fatiga tan importante como la predicha por el "factor teórico de concentración de tensiones"  $K_t$ , definido como

$$K_t = \frac{\sigma_{\max}}{\sigma_{\text{nom}}} \quad (4)$$

Es por ello que el factor empírico  $K_f$ , dado por la expresión siguiente:

$$K_f = \frac{\sigma_{fs}}{\sigma_{fn}} \quad (5)$$

debe ser usado en el diseño. La desigualdad  $K_f < K_t$  ha sido observada repetidamente en la práctica. La explicación más extendida al respecto se basa en consideraciones acerca de la deformación inelástica en la raíz de la entalla. Sin embargo, ella no da una explicación completa y consistente acerca del fenómeno. La cuestión importante que sobreviene, es la predicción del valor apropiado de  $K_f$ . Para solucionar este problema, Peterson (ref. 12) introdujo el importante concepto de "factor de sensibilidad a la entalla"  $q$ , definido como:

$$q = \frac{K_t - 1}{K_t - 1}$$

Este factor tiene el mérito de suministrar una escala para la medición de la sensibilidad a la entalla, que varía entre  $q = 0$  (efecto de entalla nulo) y  $q = 1$  (efecto de entalla total). Peterson sugiere que  $q$  depende del radio  $r_n$  en el fondo de la entalla y de la dureza del material. Sin embargo, se considera que  $r_n$  no constituye una completa representación de la entalla. Además, se ha observado que  $q$  es muy sensible a los valores experimentales y a la dispersión de los resultados. Aquí se considerará la relación entre los coeficientes  $K_t$  y  $K_f$ , a la luz del

concepto de volumen altamente tensionado.

Analisis

Introduzcamos en la ecuación (5), la fórmula empírica descripta en (3):

$$K_f = \frac{\sigma_{fs}}{\sigma_{fn}} = \frac{B \cdot V_s^{-a}}{B \cdot V_n^{-a}} = K \left( \frac{V_s}{V_n} \right)^{-a}$$

finalmente

$$\frac{K_f}{K_t} = \left( \frac{V_n}{V_s} \right)^{0.034} \quad (6)$$

Considerando ambas probetas, la lisa y la entallada, de igual diámetro, es evidente que  $V_n$  será menor que  $V_s$ ; consecuentemente,  $K_f$  será siempre menor que  $K_t$ . Se dará a continuación la relación entre  $K_f$  y  $K_t$  para probetas con entallas poco profundas, sometidas a flexión rotativa y carga axial repetida.

Para una probeta de diámetro  $d$  y radio del pedil  $r$ , la expresión para  $V$ , según se ha podido comprobar, está dada por:

$$V \approx 0.02 \sqrt{\frac{r \cdot d \cdot d}{G}} \quad (7)$$

Para probetas lisas, según (2) resultará:

$$V_s = 0.01 \sqrt{r_s \cdot d_s^5} \quad (8)$$

Y para probetas con entallas poco profundas  $G = 2.5/r_n$ . Luego en (7):

$$V_n \approx 0.008 \sqrt{r_n^3 \cdot d_s^3} \quad (9)$$

Teniendo en cuenta estas dos últimas expresiones, la ecuación (5) puede ser escrita así:

$$\frac{K_f}{K_t} = \left[ 0.8 \sqrt{\frac{r_n^3 \cdot d_n^3}{r_s \cdot d_s^5}} \right]^{0.034}$$

y para  $d_n = d_s = d$ :

$$\frac{K_f}{K_t} = (0.8)^{0.034} \cdot \frac{r_n^{0.051}}{r_s^{0.017} d^{0.034}} \quad (10)$$

Luego, la relación entre  $K_f$  y  $K_t$  depende solamente de la geometría de la sección crítica de ambas probetas, lisa y entallada, y no del material. En la parte B de la Discusión se volverá sobre este punto.

La incidencia de cada una de las características geométricas  $r_n$ ,  $d$  y  $r_s$  puede pesarse de acuerdo a la siguiente expresión:

$$\frac{d(K_f/K_t)}{(K_f/K_t)} = \pm \frac{\frac{\partial (K_f/K_t)}{\partial r_n} d r_n}{K_f/K_t} \pm \frac{\frac{\partial (K_f/K_t)}{\partial r_s} d r_s}{K_f/K_t} \pm \frac{\frac{\partial (K_f/K_t)}{\partial d} d d}{K_f/K_t}$$

Reemplazando las derivadas por sus valores y simplificando, resulta:

$$\frac{d(K_f/K_t)}{(K_f/K_t)} = \pm 0.051 \frac{d r_n}{r_n} \pm 0.017 \frac{d r_s}{r_s} \pm 0.034 \frac{d d}{d}$$

Luego, la variación de  $r_n$  tiene un efecto tres veces mayor que el de  $r_s$ , y 1.5 el de  $d$ .

De la consideración de una amplia gama de forma de probetas, se ha podido concluir que es fundamentalmente  $r_n$  el factor que puede modificar sustancialmente la relación entre  $K_f$  y  $K_t$ : una gran variación en las características geométricas de probetas lisas, sólo provocó un 15% de variación en la antedicha relación. Es por ello que, sin temor a errores importantes, puede tomarse las dimensiones de una probeta generalizada, lisa, de fatiga, como base para el análisis.

La fig. 5 resulta de considerar una probeta de  $d = 0.3$  pulg., y  $r_s = 10d$ . En estas condiciones, la (10) se transforma en:

$$K_f = K_t \cdot 1.0148 (r_n)^{0.051} \quad (11)$$

En la misma figura se han incluido 112 resultados experimentales tomados de ref. 13. Los valores de  $K_t$  variaron entre 1.4 y 2.8. Se observa que aproximadamente el 78% de los resultados yacen dentro de la banda de dispersión  $\pm 10\%$ .

A continuación se analizará la relación entre  $K_f$  y  $K_t$  para placas bajo carga axial repetida. En este caso, se ha podido determinar que los volúmenes  $V_s$  y  $V_n$  están dados por

$$V_s = 0.46 \sqrt{r_s \cdot b_s} \cdot t \cdot b_s$$

para probetas lisas. En el caso de probetas con entallas poco profundas:

$$V_n = 0.018 \sqrt{r_n \cdot b_n} \cdot t \cdot r_n$$

y para entallas profundas

$$V_n = 0.024 \sqrt{r_n \cdot b_n} \cdot t \cdot r_n$$

Estas ecuaciones fueron utilizadas para determinar los valores de  $K_f$  en placas sometidas a cargas axiales. En la tabla siguiente los valores computados se comparan con resultados experimentales extraídos de ref. 14 y 15.

$K_t$	$K_f$ calculado	$K_f$ experimental		
		Para aleación 24S-T3	Para aleación 75S-T6	Para acero SAE4130
2	1.8	1.8	1.9	1.9
2	1.6	1.8	1.9	1.7
2	1.6	1.8	1.9	1.7
4	3.0	3.1	4.0	3.4
4	2.8	2.4	3.2	2.8
5	3.6	3.4	5.0	4.7

Una banda de dispersión de  $\pm 10\%$ , incluiría el 58% de los 18 resultados compulsados.

### Discusión

#### A. Bases para la selección de la banda de dispersión de $\pm 10\%$

Dos características de los resultados de experiencias sobre fatiga que afectan la exactitud de la medición de la sensibilidad a la entalla, son la gran dispersión de los resultados y la influencia potencialmente importante de diversas variables "accidentales".

Se verán a continuación algunos de los factores que producen errores sistemáticos:

1. Forma de preparación de la probeta.  
La resistencia a la fatiga de probetas realizadas con el mismo material pero en diferentes talleres, y aun en el mismo taller pero con diferentes

operarios, puede diferir grandemente. Ese comportamiento irregular está provocado por las variaciones en las tensiones residuales, trabajado mecánico y rugosidad superficial introducidas por las diferentes técnicas empleadas en el mecanizado y pulido de probetas.

Gohn y Fox (ref. 16), han registrado por ejemplo, una diferencia del 25% en la resistencia a la fatiga de probetas de bronce fosforoso en ensayos de flexión rotativa, que habían sido maquinadas por dos diferentes talleres, pero ambos siguiendo los procedimientos normalizados por A. S. T. M. en el manual de ensayos de fatiga (ref. 17).

Aun en el caso de que las probetas sean preparadas por el mismo operario, las diferencias en los radios de las probetas lisas y las entalladas hace generalmente imposible utilizar la misma técnica de maquinado y pulido. Estos factores pueden introducir una diferencia sistemática y una falta inherente de reproducibilidad entre determinaciones experimentales de la sensibilidad a la entalla que, desde otro punto de vista, podrían ser totalmente comparables.

2. Influencia de las condiciones ambientales generalmente no controladas durante la experiencia.

La mayoría de los ensayos de fatiga efectuados a temperatura ambiente, se realizan sin control seguro de las condiciones ambientales variables periódicamente, tales como la temperatura y el contenido de humedad del aire del laboratorio. No obstante, estas variables pueden tener una pequeña pero concreta influencia en la vida de las probetas.

Así Liu y Corten (ref. 18) establecieron que el contenido de agua del aire influye en la vida a la fatiga de probetas de aleaciones de aluminio sometidas a tensiones repetidas: un incremento del contenido de agua desde 12 granos a 120 granos, por libra de aire seco, disminuyó la vida de fatiga por un factor aproximadamente igual a dos.

3. Naturaleza estadística del fenómeno de fatiga.

La fuente más importante en la dispersión azarosa de los valores experimentales de  $K_f$  reside en la naturaleza estadística misma del fenómeno de fatiga. Las heterogeneidades en el seno del material son los orígenes de las fisuras por fatiga y de la fractura consecuente. Probetas individuales de una dada población estadística exhiben una gran dispersión tanto en la vida como en la resistencia a la fatiga. En las determinaciones experimentales de  $K_f$  resumidas en la fig. 5, fue una práctica normal basar el valor de  $K_f$  en los resultados de diversas probetas ensayadas en la región del límite de fatiga (o resistencia a la fatiga a  $10^7$  ciclos). Cada investigador utilizó un gran número de probetas, pero el valor de  $K_f$  fue determinado por las pocas probetas ensayadas a tensiones muy cercanas a la resistencia a la fatiga. Luego, es válido preguntarse la importancia de la dispersión que puede estar presente en los resultados arriba mencionados. La respuesta puede provenir de la examinación de la variabilidad estadística, esto es la desviación standard que debe ser asociada a la resistencia a la fatiga.

Ensayos cuidadosamente planeados y controlados, donde todo aquello que no sea dispersión por fuente estadística fue minimizado, dieron los siguientes resultados (ref.19):

Material	$\sigma_f$ (ksi)	$\pm 0.10 \sigma_f$	+1 desviación standard	+ 2 desviaciones standard
SAE 1050	40.8	4.1	1.0	2.0
Hierro Armco recocido	29.8	3.0	2.3	4.6
SAE 4340 templ. y esferoidiz.	62.5	6.3	2.7	5.4
SAE 43440 templ. y normaliz.	97.6	9.8	7.2	14.4

La tabla anterior indica que una banda de dispersión de  $\pm 10\%$  cubre un rango levemente mayor a una desviación standard en dos casos, levemente superior a dos desviaciones standard en un tercer caso y cerca de 4 desviaciones standard en el cuarto.

Siendo  $K_f$  la relación de dos valores de resistencia a la fatiga, es apropiado determinar cómo la desviación standard de  $K_f$  está relacionada con ellos. Para un cociente tal como

$$K_f = \frac{\sigma_{fs}}{\sigma_{fn}}$$

la desviación standard está dada por (ref. 20)

$$S_{K_f}^2 = \bar{K}_f^{-2} \frac{S_{\sigma_{fs}}^2}{\sigma_{fs}^2} + \bar{K}_f^2 \frac{S_{\sigma_{fn}}^2}{\sigma_{fn}^2} \quad (12)$$

donde  $\bar{K}_f$ ,  $\bar{\sigma}_{fs}$  y  $\bar{\sigma}_{fn}$  son los valores medios de  $K_f$ ,  $\sigma_{fs}$  y  $\sigma_{fn}$  respectivamente.

De la (12) puede deducirse la siguiente expresión, donde

$$S_{\sigma_{fs}} = \alpha \cdot S_{\sigma_{fn}}$$

y en donde frecuentemente  $\alpha \gg 1$ , desde el momento que las probetas entalladas exhiben menos dispersión que las lisas:

$$\frac{S_{K_f}}{\bar{K}_f} = \sqrt{\left(\frac{\alpha}{(\bar{K}_f)^2}\right)^2 + 1} \frac{S_{\sigma_{fn}}}{\bar{\sigma}_{fn}} \quad (13)$$

Es obvio que la relación

$$S_{K_f} / \bar{K}_f$$

B.

má  
la  
re  
plá

su  
tal  
pu  
rá

Cc

es mayor que el cociente

$$S_{\bar{\sigma}_{fs}} / \bar{\sigma}_{fn}$$

y (como se puede mostrar en forma análoga) de

$$S_{\bar{\sigma}_{fn}} / \bar{\sigma}_{fn}$$

pues el valor del término bajo la raíz es necesariamente mayor que la unidad. Luego, el ancho de la banda de dispersión de  $K_f$  expresada en porcentaje de  $K_f$ , es mayor que la banda de dispersión asociada con  $\bar{\sigma}_{fs}$  o  $\bar{\sigma}_{fn}$ . Una vez acumuladas las fuentes de dispersión arriba mencionadas, puede concluirse que la banda de dispersión de  $\pm 10\%$ , da una estimación conservativa de la dispersión que debe esperarse en determinaciones de  $K_f$ , siempre que una ocurrencia de características especiales del material, geometría de la probeta, etc., no concurren para dar una falta bastante inusual de dispersión.

De los resultados que se muestran en la fig. 5, donde el 78% de los 112 puntos incluidos caen dentro de esa zona de dispersión, puede estimarse que la banda de  $\pm 10\%$  corresponde aproximadamente a 1.2 desviaciones standard.

Si bien un análisis más exacto de la dispersión sería deseable, la falta de resultados tratados estadísticamente, lo hace en la actualidad imposible.

## B. Alcance y limitaciones de la presente tentativa

El autor de este estudio supone que otras características geométricas, además del ya mencionado volumen V, tienen una influencia, aunque pequeña, en la relación entre  $K_f$  y  $K_t$ . Entre ellas podrían encontrarse los siguientes factores: dureza del material, heterogeneidades de la estructura cristalina y deformaciones plásticas localizadas.

Para el objeto de una estimación apropiada de  $K_f$  a usar en el diseño, se sugiere pues modificar  $K_t$  según el concepto del "volumen altamente tensionado" tal como fue expresado en la ecuación (6). Según los resultados dados en la fig. 5 puede anticiparse que en 4 de cada 5 casos, el valor de  $K_f$  así determinado, estará dentro de  $\pm 10\%$  de error.

## Conclusiones

Los resultados de este estudio parecen justificar las siguientes conclusiones:



1. La resistencia a la fatiga de los metales disminuye a medida que el volumen tensionado de material en la superficie, aumenta. Una región altamente tensionada que cubra, por ejemplo 95% y más de  $\sigma_{\max}$ , puede ser considerada para el diseño.
2. Se ha encontrado una función lineal, con una pendiente suficientemente invariable para muchos metales, en la relación entre el logaritmo del volumen  $V$  y la tensión máxima del material. La ecuación de esta recta puede definirse para un dado material conociendo solamente un valor de resistencia a la fatiga; la tensión máxima para  $V_1 = 0.000349 \text{ pulg}^3$ , que corresponde a una probeta lisa de 0.25 pulg de diámetro y  $r = 1.25 \text{ pulg}$ , sometida a un ensayo de flexión rotativa.  
Comparando esta ecuación con resultados existentes en ensayos de flexión alternada y rotativa, se encontró un error máximo de 10%.
3. Partiendo del mismo concepto, es posible inferir la desigualdad  $K_f < K_t$ .
4.  $K_f$  depende de  $K_t$ , el radio de las probetas lisas y entalladas y del diámetro  $d$ ; sin embargo, la influencia de  $K_t$  y el radio de la probeta entallada, son los factores más importantes.
5. La relación entre  $K_f$  y  $K_t$  para probetas sometidas a flexión rotativa, está registrada en la ecuación (10) y en la fig. 5. Examinados resultados experimentales, se observó que el 78% de los resultados estuvieron incluidos dentro de una banda de dispersión de  $\pm 10\%$ .
6. Experiencias ulteriores, actualmente en desarrollo, permitirán verificar sistemáticamente las expresiones aquí adelantadas.

## BIBLIOGRAFIA

1. H. NEUBER, "Theory of notch stress: Principles for exact stress calculation", Ann Arbor, Michigan, J. W. Edwards, 1946.
2. G. V. UZHIK, "Mechanical Aspect of size effect on fatigue of metals", Londres, Conferencia Internacional ASME-IME, Sesión 2, Trabajo 17, 1956.
3. F. B. SEELY y J. O. SMITH, "Advanced Mechanics of Materials", 2da. edición, New York, John Wiley, 1952.
4. W. WEIBULL, "A statistical theory of the strength of materials", Proceedings, Inst. Real Sueco para la Investigación en Ingeniería, No. 151, 1939.
5. A. M. FREUDENTHAL, "The statistical aspect of fatigue of materials", Journal, Royal Society of London, Serie A, v.187 (1946), p.416.
6. D. MORKOVIN y H. F. MOORE, "Third progress report on the effect of size of specimen on fatigue strength of three types of steel", Proceedings, A. S. T. M., v.44 (1944), p.137.
7. H. F. MOORE y T. J. DOLAN, "The effect of size and notch sensitivity of fatigue characteristics of two metallic materials", A. F. T. R. No. 5726, Air Materiel Command, U. S. A. F., Octubre, 1948.
8. R. KUGUEL, "The highly stressed volume of material as a fundamental parameter in the fatigue strength of metal members", T. A. M. Report 169, Universidad de Illinois, Urbana, Illinois.
9. H. T. CORTEN y T. J. DOLAN, "Shape as a factor in flexural fatigue strength" T. A. M. Report 84, Universidad de Illinois, Urbana, Ill., 1955.
10. T. J. DOLAN, J. H. McCLOW y W. J. CRAIG, "The influence of shape of cross section on the flexural fatigue strength of steel", Transactions, A. S. M. E., v.72 (julio 1950), p.469.
11. C. W. RICHARDS, "Effects of size on the yielding of mild steel beams", Proceedings, A. S. T. M., v.58 (1958), p.958.
12. R. E. PETERSON, "Stress concentration design factors", John Wiley, New York, 1953.
13. P. KUHN y H. F. HARDRATH, "An engineering method for estimating notch-size effect in fatigue test on steel", NACA TN 2805, 1952.
14. H. J. GROVER, S. M. BISHOP y L. R. JACKSON, "Fatigue strength of aircraft materials", NACA TN 2324, 1951.
15. H. J. GROVER, S. M. BISHOP y L. R. JACKSON, "Fatigue strength of aircraft materials", NACA TN 2389 y NACA TN 2390, 1951.
16. G. R. GOHN y A. FOX, "The R. R. Moore Rotating beam Fatigue Test", Proceedings, A. S. T. M., v.59, 1959.
17. ASTM, "Manual of fatigue testing", STP No. 91.
18. H. W. LIU y H. T. CORTEN, "Fatigue damage under varying stress amplitude", NASA TN D-647, 1960.
19. E. EPREMIAN y F. R. MEHL, "Investigation of statistical nature of fatigue properties", NACA TN No. 2719, 1952.
20. W. WOLK, "Applied statistics for engineers", McGraw Hill, New York, 1958.

## NOTACION

A	Area formada por la intersección del volumen altamente tensionado V, con un plano pasante por el eje de la probeta.
a	Exponente.
B	Coefficiente dependiente del material.
b	Ancho de una placa.
d	Diámetro crítico o más pequeño, de una probeta.
d'	Diámetro de una probeta, en los extremos.
d <sub>1</sub>	Distancia entre los centros de gravedad de las áreas A.
G	Gradiente específico de tensiones.
K <sub>f</sub>	Factor real de entalla.
K <sub>t</sub>	Factor teórico de concentración de tensiones.
q	Factor de sensibilidad a la entalla.
r	Radio del perfil de una probeta.
S	Desviación standard.
t	Espesor de una placa.
V	Volumen de una probeta, sometido a 95% y más de la tensión máxima.
$\Delta$	Semibase del triángulo formado por el área A.
$\sigma_f$	Tensión de fluencia
$\sigma_f$	Límite de fatiga de un metal. (Para aleaciones de aluminio, la tensión correspondiente a 10 <sup>7</sup> ciclos).
$\sigma_{max}$	Tensión máxima.
$\sigma_{nom}$	Tensión nominal.
$\sigma_u$	Tensión de rotura estática.

## Subíndices

n	Para probeta entallada.
s	Para probeta lisa.



Figura 1 Características Geométricas y Distribución de Tensiones en el Area A de una Probeta para Flexión Rotativa



Figura 2 Relación entre la Tensión Máxima ( $K_t T_{nom}$ ) y el Volumen Altamente Tensionado (Ref. 10)

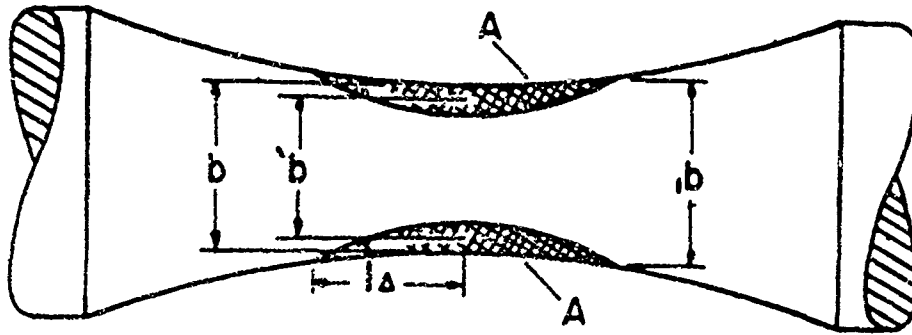

Volumen de material altamente tensionado, pulg.<sup>3</sup>

Figura 3 Relación entre la Tensión Máxima ( $K_t T_{nom}$ ) y el Volumen de Material Altamente Tensionado, para la Aleación de Aluminio 24 SPT (Ref. 9)

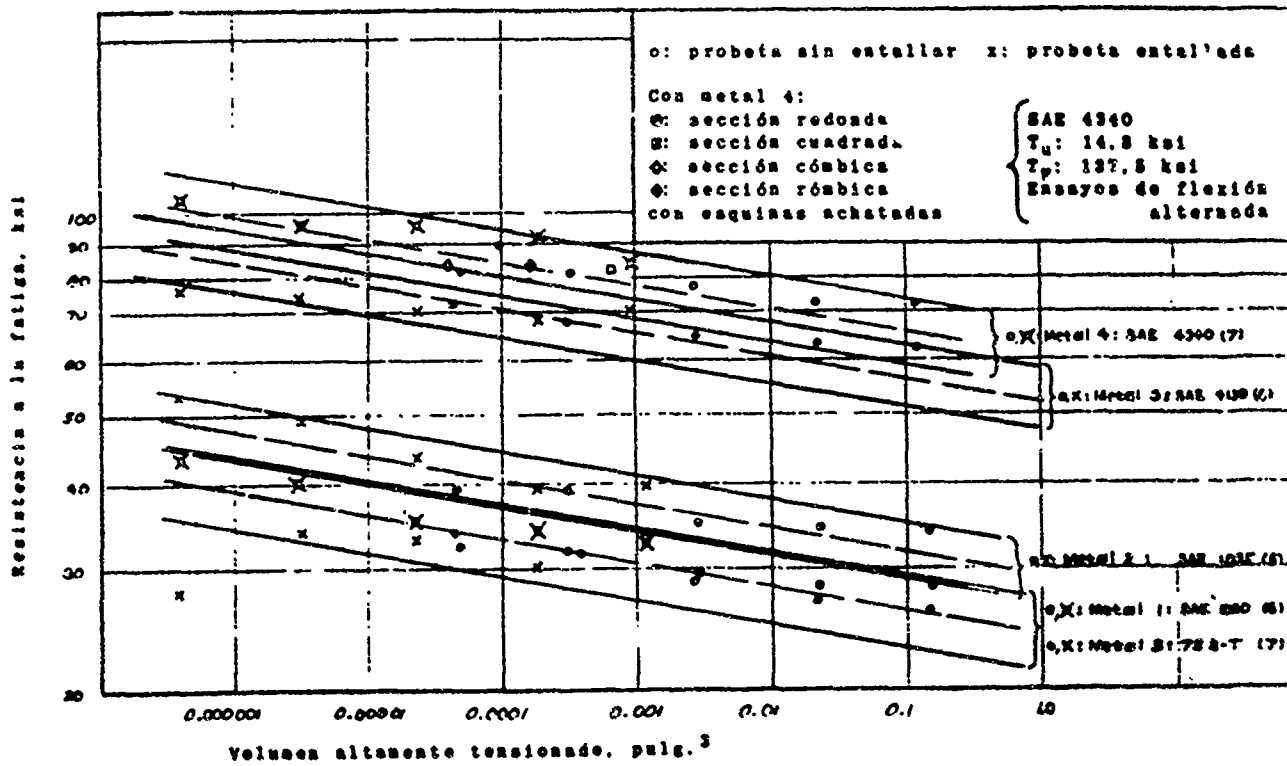
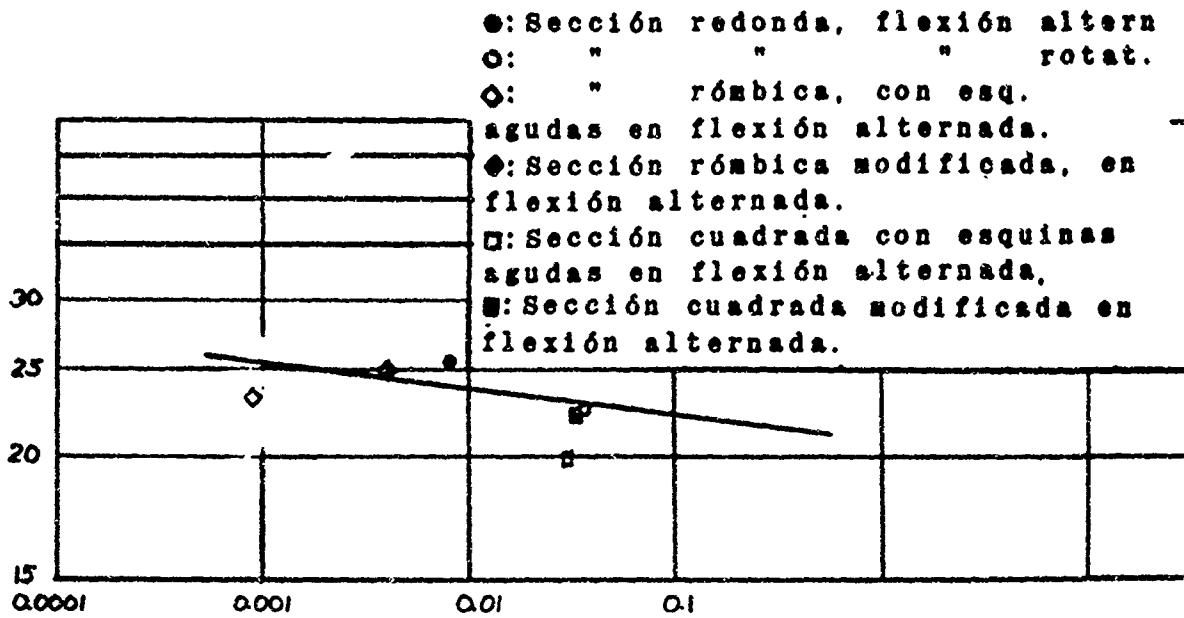

Figura 4 Relación entre la Resistencia a la Fluencia y el Volumen Altamente Tensionado. Ensayo Estático. Material: Acero con 0,18% de C



Figura 5 Relación entre  $K_f$  y  $K_t$  para  $d = 0,3$  pulg.,  $r_g = 10 d$ ,  $r_n = t = 0,003$  a  $0,090$  pulg.

"ESTRATEGIA DE LA INVESTIGACION METALURGICA  
EN LATINO AMERICA"

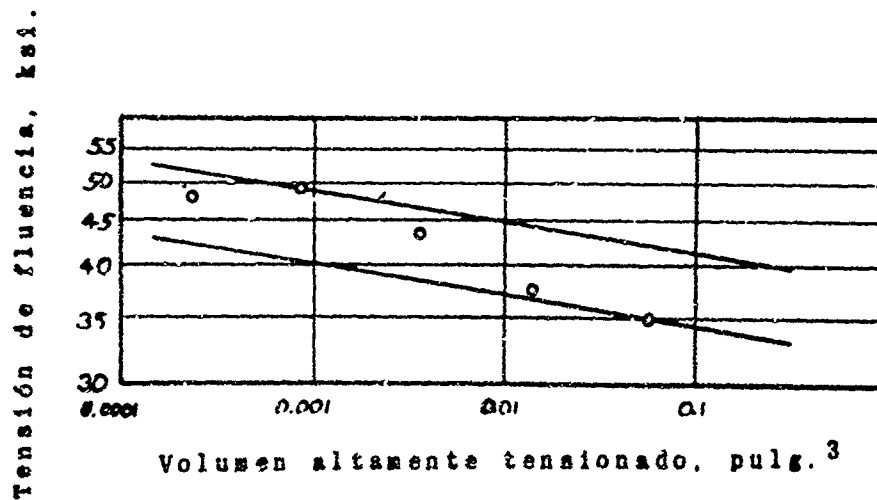
por Jorge Sábato

Si el Dr. Villanueva comenzó su exposición diciendo que eran bases preliminares para una discusión de una metodología general, Uds. me van a disculpar, porque las mías son bases preliminares para las bases preliminares del Dr. Villanueva. De manera que traer este tema a esta reunión ha tenido un objetivo fundamental que es, como el de muchos otros que se han traído a esta conferencia, la de producir una determinada inquietud en los que trabajan en metalurgia, por un lado y en los que planifican la economía y el desarrollo por otro.

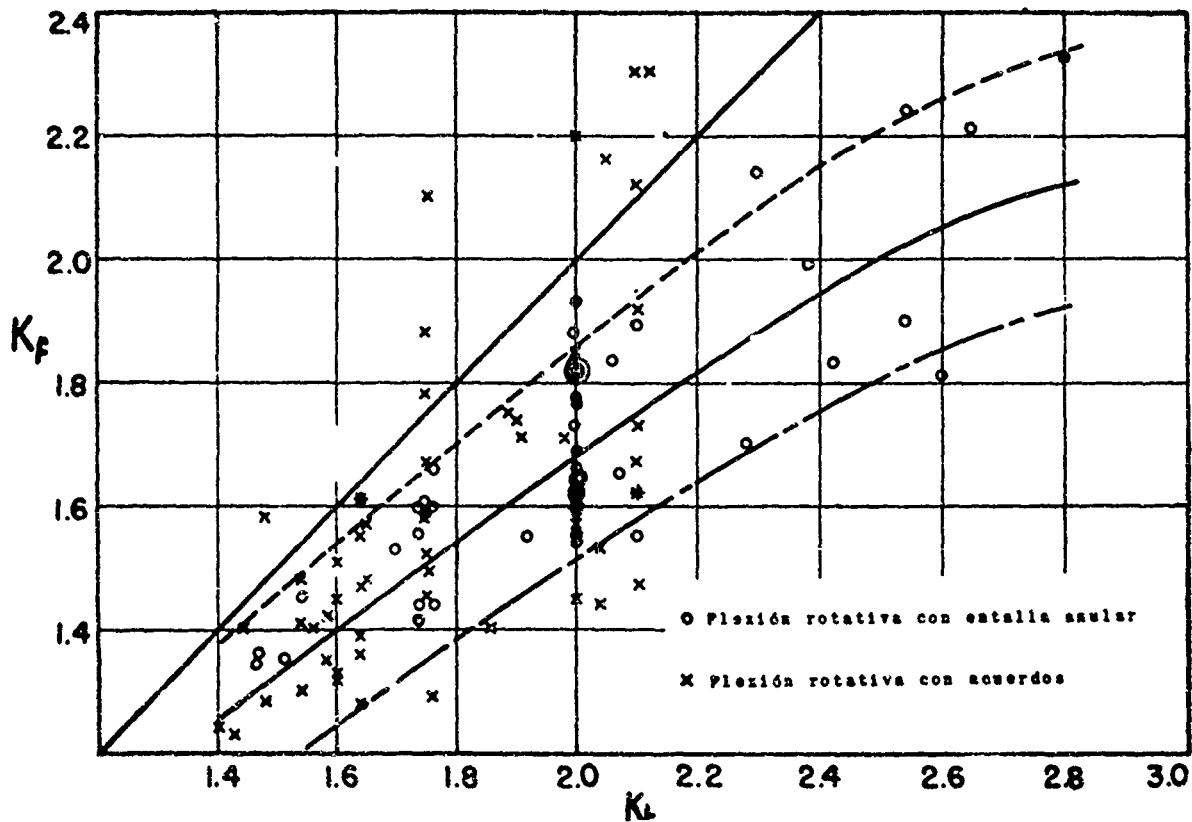
Corresponde naturalmente a una tendencia moderna que adquiere su aspecto más orgánico en los trabajos que realiza la O. E. C. D. en Europa. Por cuanto al tener que fijar y determinar la estrategia en varios países y al hacer cuenta de los recursos disponibles, la O. E. C. D. ha organizado comités especiales, meetings, reuniones de ministros de ciencia, etc., con el objeto de tratar de planificar o de fijar algunos términos de planificación para la investigación científica y/o técnica. El problema en términos generales es muy simple: frente al universo de cosas por investigar, evaluar los riesgos de la investigación, como lo expresara el Dr. Villanueva. En particular los riesgos medidos, no de una empresa particular, sino en una forma teórica general, para todo el mecanismo económico general. Teniendo en cuenta estos dos factores, no cabe ninguna duda que la preocupación, en particular en el caso de los miembros de la O. E. C. D., está fundamentada. Reflexionemos: si en el caso de la O. E. C. D., es decir en el caso de los países Europeos, esa preocupación está fundamentada, en países de estructura mucho más débil, como los países latinoamericanos, la fundamentación es muchísimo más obvia.

Si los recursos disponibles son escasos y si para emplear esos recursos disponibles no trazamos una estrategia adecuada, el rendimiento social de esos recursos será mucho menor todavía que si para los mismos dispusiéramos de una política inteligente. Por supuesto que estas son cosas generales por cuanto están en la base de la creación de los organismos denominados Consejos Nacionales de Investigación que existen en varios países latinoamericanos y que en los que no existen muy pronto se van a crear.

Pero es una preocupación moderna, por supuesto, es una preocupación que hubiera producido aberración no solamente a los economistas liberales sino a los

políticos liberales. Pero corresponden por otra parte a una realidad, que como siempre ocurre, es mucho más fuerte que los esquemas teóricos pre-existentes. En ciencia, como en otras actividades, habrá que planificar. Este es un imperativo. Conviene mucho que los que hacen investigación comiencen a pensar en este problema, por cuanto si nó, les ocurrirá lo que ha ocurrido en otras actividades: que serán planificadas de buenas a primeras, sin consultar su opinión y sin siquiera haber llegado a la preocupación del problema. Con el Dr. Villanueva revisamos bastante bibliografía sobre este tema, y encontramos que los tratamientos generales son débiles, que no hay una metodología a la cual podamos recurrir como criterio, como cartabón filosófico. Lo que hay son tentativas, aproximaciones al problema.

Toda vez que me encuentro que sólo hay aproximaciones tentativas en un problema, eso me alegra porque así tenemos chance de intervenir en la elaboración del mismo. Si el esquema teórico general -digo- es débil, la metodología misma está todavía en elaboración. Nosotros hemos pensado que lo interesante, por un lado sería tratar de hacer algún esquema teórico, como el que el Dr. Villanueva presentó, y por otro lado comenzar a aplicar algunas de esas ideas a una disciplina específica.

En lugar entonces de ocuparnos de la investigación científica, de la investigación tecnológica, como concepto general, entrar en una disciplina, en un área determinada, donde tenemos un producto un poco más evaluable que además lo podemos referir a necesidades y posibilidades nacionales de corto, de mediano y de largo alcance.

Por lo tanto, si el informe que presentó el Dr. Villanueva puede ser calificado de teórico y general o abstracto y general, sin que ninguno de esos tres adjetivos sean peyorativos, sino descriptivos, lo que yo voy a proponer ahora es exactamente la antítesis de eso: es un análisis muy crudo, muy descarnado, muy sobre elementos primarios de la metalurgia. Y lo hacemos un poco de intento, porque así podemos comenzar a ver si ciertas ideas generales se pueden aplicar al análisis de situaciones particulares.

Conviene que diga algunas cosas para beneficio de las personas que no están familiarizadas con la industria metalúrgica. Algunos datos referentes a esta industria, en el contexto de la economía Argentina. Las que voy a decir son muy breves, y fáciles de recordar, pero justifican un poco que si hacemos un esfuerzo en la dirección que he dicho sobre metalurgia, tendrá alguna significación social y económica.

Si evaluamos la importancia de la industria metalúrgica en términos del producto bruto nacional, a la industria metalúrgica le corresponde el 10% del producto bruto, según los datos de 1963. El número de establecimientos de la industria metalúrgica, referido al número total de establecimientos de la industria general, es del 27%; el número de obreros empleados en la industria metalúrgica es del 32%, respecto al total de obreros empleados en la industria manufacturera general.



Estos tres parámetros, estos tres datos, dan idea de que hacer un esfuerzo en el sector de la metalurgia es importante no solamente porque sea nuestro oficio, sino que además tendrá una significación económica social importante. Se podría aproximar el problema de una evaluación de las prioridades en la investigación metalúrgica, sobre bases del siguiente tipo:

Se podrían proponer influencias de corto, mediano y largo alcance en la economía nacional. Para dar un ejemplo: si tomamos un problema de corto alcance podríamos tratar de evaluar en él el riesgo que incurriremos en investigar ese problema y los beneficios que obtendría la sociedad en términos sociales y económicos.

Hago hincapié sobre esto de la sociedad y no de un establecimiento o una industria particular, porque entiendo que no cabe discusión alguna que en países de la estructura nuestra, países en desarrollo, no cabe ninguna duda deberá haber organismos de planificación que fijarán los objetivos sociales, no los objetivos individuales de determinado sector. Y digo que importa decir esto en términos sociales, porque es muy frecuente encontrarse con casos como este...:

Una persona viene y le dice a uno: Ud. qué investiga?

Y uno le contesta: un tema cualquiera -digamos dislocaciones- por decir una cosa muy abstrusa...

Qué lástima! Uds. tendrían que investigar cosas concretas.

Entonces uno dice: Qué son cosas concretas?

Cosas concretas son los clips, como éste que tengo en la mano. Fíjese que los que yo fabrico se rompen.

Uno le contesta: Qué lástima que se le rompan, trate de que no se le rompan... (puede ser una respuesta).

Entonces el señor irá muy disgustado y dirá: En lugar de estudiar dislocaciones, debería estudiar cosas concretas, como los clips.

Claro, son cosas concretas para él, que mide los términos de su problema, de su realidad de hoy a las 8 de la mañana, porque a las 10 quizás ya no fabrica más clips. Si uno pudiera evaluar el estudio de dislocaciones en términos sociales, a lo mejor es mucho más importante que los clips de aquél señor.

Un ejemplo posible en el caso particular de la Argentina podría ser el hierro silicio para transformadores. En este caso nadie viene a golpear la puerta para hacer preguntas científico-técnicas, porque el señor que importa el hierro silicio para los transformadores y los construye, no tiene ningún problema de ese tipo. Su negocio no es el hierro silicio; su negocio son los transformadores. Si él dispone de hierro silicio en el mercado internacional y a lo mejor hace buenos negocios con cosas laterales al hierro silicio, no tiene una preocupación latente. La tendrá el día que se cierre la importación, el día que sobrevenga una guerra, o el día que existan mecanismos de presión. En ese momento el problema se transforma para él en un algo concreto. Entonces el diagnóstico que debemos hacer debe conducirnos a determinar cuáles son los problemas concretos en términos sociales.

Eso nos va a decir cuáles son los problemas concretos para hoy o para mañana. Esos problemas concretos, en términos sociales, no están relacionados a un individuo o a una preocupación individual solamente. Debieran estar relacionados a un análisis en amplitud y en profundidad. Los países no han hecho esto muchas veces. Hay muchos ejemplos de que en los países, como estructuras sociales, no ha habido el incentivo directo del beneficio económico a que se refería el Dr. Villanueva anteriormente.

No es cierto que individualmente uno tenga presente esa necesidad social. En una economía de mercado lo que uno tiene presente son sus beneficios y éste es su objetivo fundamental; para eso está. Entonces, cuando decimos analizar prioridades de investigación en términos sociales y no individuales, determinación de riesgos de investigación en términos sociales y no individuales, y enumeración en forma de lista o nómina de los problemas concretos de la metalurgia en un país, nos volvemos a referir a términos sociales.

Entonces, en los problemas de corto alcance una primera aproximación muy grosera, insisto que muy grosera, pero es una hipótesis de trabajo, sería analizar la sustitución de productos metalúrgicos por su influencia directa en la balanza de pagos. Esto que se hace cuando hay una emergencia nacional, una guerra, un bloqueo, en lugar de hacerlo por una emergencia nacional podríamos hacerlo con plena conciencia. Analizamos la lista de productos metalúrgicos que importa el país y observamos su incidencia sobre la balanza de pagos. Medimos de esa manera su costo social, y esbozamos inmediatamente una primera lista, por así decir, de importancia. Esta lista no basta.

Aquí estaría la lista en relación con los términos de la balanza de pagos. No basta esta lista si no ponemos al lado otra lista que diga qué es lo que nos impide elaborar, manufacturar estos productos que aquí estamos importando. El impedimento no son sólo dificultades tecnológicas o científicas; pueden ser conveniencias nacionales, políticas, de todo tipo. El organismo de planificación también deberá evaluar esto y darle algún tipo de prioridad; deberá analizar esas causas.

Por último tendríamos que hacer una tercera tabla y evaluar si los impedimentos que nos impiden elaborar son de naturaleza tecnológica, o bien el producto está protegido por una red de patentes, por así decirlo, que impiden entrar a nosotros en su manufactura. Son productos cuyas inversiones de capital exceden posibilidades nacionales? Este análisis tiene que ver con el estado del producto en el mercado mundial; es decir, como son las reglas del arte de elaboración de tecnología y de ciencia, que están subyacentes en el producto en cuestión.

Con estas tres listas uno puede comenzar a hacer una primera secuencia de prioridades. Por supuesto por debajo de todas están las posibilidades existentes en el país, en materia de investigación. Si el país no tiene investigación toda esta lista -por supuesto- es ridícula.

Estoy partiendo de la base de que hemos aprendido la lección No. 0. Un país debe tener un estudio de investigación determinado. Esa lección la aprendimos hace bastante tiempo. Aunque no la hayamos aprendido del todo, aprendimos lo más importante. Entonces, esta primera aproximación de corto alcance (digo "de corto" porque solamente se ha tenido en cuenta un aspecto del problema económico, que es el impacto en su balanza de pagos), puede conducir por ejemplo, en el caso de la economía Argentina, a algunas cosas interesantes: la Argentina importa normalmente 20 millones de dólares aproximadamente en hojalata para envases de productos alimenticios. Ha sido una importación tradicional argentina, por supuesto. Estos 20 millones de dólares es una parte importante de nuestra importación anual, por cuanto importamos en el orden de los mil millones de dólares de productos totales, de manera que 20 millones de dólares no es una cifra ridícula o pequeña.

Qué importancia tendría una investigación que analizara aspectos tales como los siguientes: Por qué hojalata en tales envases o para tales productos? Por qué no otros productos? Por qué no aluminio? Por qué no plástico? Por qué no vidrios? Además: Por qué hojalata de tanto espesor, por qué hojalata de tal medida?

Y finalmente: Por qué no disminuir no solamente el espesor de la chapa sino el espesor del recubrimiento mismo, cuando este incide tanto en el producto final. Bueno, un desmenuzamiento de este tipo, del proceso, (estoy tomando un ejemplo relativamente ficticio, excepto los 20 millones de dólares), pero un desmenuzamiento de este problema tiene sentido por una razón muy importante: porque la tecnología de la hojalata es una tecnología vieja en el mundo. Existen numerosos sustitutos y sucedáneos que han sido desarrollados en otros países y que no han sido aplicados a sus economías respectivas, porque las inversiones de capital que están detrás de la industria de la hojalata, obstruyen esa aplicación. Por lo tanto, en el mercado internacional hay conocimiento en hojalata disponible, que podría ser transferido a la realidad nacional, re-analizado en términos del problema específico, y aplicado, si así fuere conveniente.

Pero hay algo más todavía: ése es un proceso dinámico, y así hemos visto hoy sorpresas mucho mayores que las de la hojalata, cuando hemos visto en las conferencias los otros días, la importancia de la fibra de vidrio en una cantidad de aplicaciones tradicionalmente metalúrgicas. En este terreno particular, el campo de posibilidades de creación original en términos de los productos nacionales o de los recursos nacionales- está muy abierto. Tendría sentido financiar, apoyar financieramente, investigaciones en este territorio. Y uno podría llegar en un segundo análisis a una valuación de riesgo, en la medida que uno dijera: si importamos 20 millones de dólares anuales de hojalata y un desplazamiento en su uso por otras cosas, puede reducir este costo social en dos millones de dólares, podemos saber cuánto valdría -en términos sociales- una investigación en hojalata.

Podríamos así arriesgar 2 millones de dólares, por cuanto si los perdiésemos sería una pérdida medida y en relación con una probable ganancia importante.

Entonces se podría hacer eso a través de un mecanismo crediticio adecuado, a través de un mecanismo de seguro o a través de los mecanismos de costo social que tiene toda economía.

Otro caso parecido al de la hojalata, con algunas variantes, es el de hierro silicio para transformadores. El país importa anualmente el orden de 10,000 tons. de chapa de hierro silicio. Hierro silicio para transformadores es una necesidad en todos los países, de cualquier parte del mundo, que comiencen cualquier proceso de industrialización, particularmente de electrificación. Una fábrica de transformadores es un buen símbolo de nivel tecnológico de un país. El hierro silicio es un material desarrollado y perfeccionado sobre todo en los últimos años por algunas firmas -particularmente americanas- que han protegido además ese desarrollo con una red de patentes tan cerrada que las firmas inglesas, en el mercado de hierro silicio, están ahora embarcadas en una investigación de manera tal de reemplazar el silicio en el hierro silicio, por cuanto de lo contrario no hay salida para esa trampa de patentes.

Acá tenemos un caso en el que no solamente hay un costo social sino un costo político. Por cuanto en la medida en que sobre el hierro silicio (que es un material tan estratégico como el cobre o más) haya un conocimiento, una tecnología monopolizada de una determinada manera, dependiente de una determinada estructura, nosotros tendremos no solamente un cuello de botella económico, sino un cuello de botella técnico. Entonces uno debe preguntarse cuál es el estado del arte de hierro silicio.

Esta es la segunda tabla a la que me refería anteriormente; es muy importante porque, claro, si el estado del arte es tal que nuestras chances de hacer algo en hierro silicio son cero, o casi cero, entonces el costo será tan grande que no podremos tomarlas. Esto exige un análisis con bases tan sólidas en metalurgia para saber a que distancia, o que dificultades son las que hay que vencer, que solamente un sólido conocimiento básico metalúrgico en un equipo de investigación puede dar la valoración correcta de esto. Y si uno no es capaz de darla, pues entonces puede no solamente no resolver el problema, que eso puede ocurrir muchas veces, sino cometer un desatino comenzándolo a estudiar.

En el caso particular del hierro silicio, para terminar con él, mi opinión personal (y a lo mejor en la audiencia va a haber mucha gente que difiera conmigo, y estaré encantado de que así sea) es que el conocimiento que ha derivado de esa malla de patentes es un conocimiento alcanzable, si se poseen conocimientos básicos fundamentales y se sabe, por supuesto, el oficio de investigar. Si se lo ignora no tiene sentido.

Los ejemplos de largo alcance tienen que partir de un análisis distinto que los de corto alcance. Los de corto alcance son basados en análisis inmediato de cosas, como la balanza de pagos, etc. Los de largo alcance tienen que basarse en un análisis distinto, que consiste esencialmente no en la predicción del riesgo económico, sino en algo diferente, en la predicción del cambio tecnológico. Ha-

cia donde va a cambiar la tecnología metalúrgica en los próximos 15 años. Una evaluación acertada del cambio de la tecnología metalúrgica en una determinada dirección, constituiría para un país en desarrollo, la posibilidad de un salto gigantesco en su desarrollo técnico, por cuanto le daría la oportunidad de convertirse de comprador de royalties, de pagador de "know-how" en el estado de subdesarrollo, al estado inverso: de exportador de conocimiento, exportador de "know how". Y lo que es más importante: una predicción adecuada del cambio permitiría que el país no instale industrias o tecnologías que son obsoletas en el momento mismo en que el país está tomando la decisión.

Estados Unidos posee instituciones especializadas en el análisis de la predicción de cambios tecnológicos. Rusia, por supuesto, en su estructura económica, filosófica más que económica, tiene subyacente este tipo de análisis. La O. E. C. D. está emprendiendo este análisis para ramas concretas de las disciplinas técnicas. Los países de América Latina deberán hacerlo con mayor razón todavía.

En el caso concreto, en el caso específico de la metalurgia, la predicción de cambio se podrá hacer en función de un análisis acabado del estado del arte actual, de un análisis de la proyección de las investigaciones en curso.

El Dr. Steinberg dió un muy buen ejemplo de ésto en un caso muy simple en el fondo pero muy interesante, de las visiones para la década del 60 de las propiedades para materiales destinados a los motores de cohetes: vidrio (en caso de ser fabricados en vidrio) titanio o acero. El programa MEP que expusieron ayer el Dr. Reed y el Dr. Promisel, no es otra cosa que la previsión del cambio tecnológico en acción, pagado con el presupuesto social del país, para determinar "de facto" cuáles van a ser aquellas direcciones de cambio más importantes. Lo menos que debemos hacer nosotros es estar muy vigilantes al programa que expusieron el Dr. Reed y el Dr. Promisel. Porque ellos no solamente están haciendo una predicción teórica, sino que están invirtiendo no se cuántos millones de dólares en producir la predicción a través de la investigación concreta.

Nada más.

OBJETIVOS DE UNA COLABORACION REGIONAL  
EN MATERIA DE INVESTIGACION TECNOLOGICA

por Jorge Sábato

De acuerdo al programa preparado para la Conferencia, la Secretaría de Organización dispuso que en la sesión de hoy se discutieran medios para continuar esta tarea que hemos comenzado ahora. La experiencia ha servido para que discutiésemos una cantidad de problemas y, más importante aún, para que nos conociésemos y encontrásemos la manera de seguir adelante.

Quiero recordarles a todos los presentes que esta reunión no ha sido otra cosa que la consecuencia de la reunión de Bogotá de enero de 1963 convocada por la OEA con el objeto de discutir la manera de llevar adelante una colaboración regional en materia de investigación tecnológica, y que Metalurgia fué una de las áreas discutidas en aquella conferencia y elegidas para que se celebrasen reuniones regionales en las cuales habría que encontrar la manera de llevar a cabo esa colaboración. Por lo tanto, el meeting en conjunto de toda la semana debe ser tenido como la preparación básica y el primer paso hacia un programa más ambicioso que naturalmente no se pretende estructurar ahora en detalle ni mucho menos, sino dar un pasito más adelante.

De esta reunión para adelante deberán ocurrir otras cosas, deberemos hacer otras cosas. No debe terminar naturalmente en una simple expresión de buenos deseos, sino que la Secretaría de Organización está animada del propósito de que así como realizamos esta conferencia, realicemos otras cosas.

En tal sentido voy a sugerir algunas de las cosas que podrían hacerse y el debate ilustrará sobre otras cosas más. Esta es una lista tentativa y de ninguna manera completa.

Yo quisiera, antes de empezar a enumerar esta lista, pedir que todos ustedes contribuyan con sus propias ideas y que en alguna medida nuestra discusión de hoy esté realizada bajo el lema siguiente: no pretendamos la perfectabilidad, sino consigamos formas de hacer.

Hay una expresión inglesa que todos ustedes creo que conocen y es "wishfull thinking" (buenos deseos) y muchas veces en el pasado esto ha sido bastante tradicional en las asambleas o reuniones latinoamericanas donde se levantan las copas

y se brinda por la felicidad de todos, el amor que todos nos tenemos y la herencia hispánica común, un gran destino, pero cuando nos volvemos a casa nos olvidamos de que eso hay que implementarlo con acción. Es decir, no sirve para nada y creo que ha sido el pecado nuestro desde que América Latina hizo la gran hazaña de liberarse de España, que fué una obra común. Desde entonces a la fecha parece que hemos padecido de una especie de esquizofrenia literario que nos conduce, como digo, a tener expresiones de muy buenos deseos y muy poca capacidad de acción.

La secretaría está inspirada en el propósito exactamente opuesto: que se realicen determinadas cosas, no las mejores, no las más perfectas, no todas, no de manera global y para siempre, sino de a pasos, como se construyen todas las cosas desde la familia hasta los países.

He aquí algunas de esas ideas:

#### 1. Entrenamiento del personal

La revisión de lo que está ocurriendo en los distintos institutos muestra claramente que la necesidad de personal calificado es seria y que va a ser mucho más seria en los próximos años.

El entrenamiento de personal puede consistir en muchos tipos de cosas. Puede haber cursos regionales abiertos a todos los países, puede haber cursos de un área que por razones de comodidad o de transporte, por ejemplo digamos de Chile-Uruguay-Argentina, puede ser Chile-Perú-Colombia, tampoco tienen por que ser todos, pueden ser los que más convenga, los cursos pueden ser de naturaleza general si hay áreas de debilidad o pueden ser de temas muy específicos. Algunos de esos cursos regionales han existido ya y existen, podría citar el curso que el Departamento de Metalurgia de la Comisión realizó en el 62, llamado "primer curso panamericano" que contó con becarios de nueve países de Latinoamérica. Hay otro curso parecido programado para el año 1965, que va a comenzar el 15 de marzo, de una duración de 10 meses. En estos cursos, tanto en el anterior como en este, como Uds. saben se da mucho énfasis a dar una preparación muy sólida en ciertos aspectos de la metalurgia y se descuidan otros porque no se pretende abarcar todos.

Ese curso en alguna medida puede ser una buena chance para que ciertos institutos envíen becarios. Cursos que han existido a nivel interno como los cursos de la A. B. M. (Asociación Brasileña de Metales) que se organizan anualmente son exitosos, muy conocidos y ha dado origen uno de ellos a la publicación del Dr. Correa Da Silva que creo todos conocemos aquí, podrían ser una posibilidad de que los Institutos se pusieran en contacto con la Asociación Brasileña o solicitaran la posibilidad de enviar técnicos y becarios a sus cursos, que se conociera con suficiente anticipación cuando van a ser, que temas, quiénes van a venir, etc., y habrá otras posibilidades que Uds. seguramente van a exponer.

El otro problema en materia de entrenamiento de personal, además de los cursos de este tipo, sería el problema de entrenamiento de investigadores en el sentido más general de la palabra, sin restringirlo de ninguna manera a la investigación llamada básica sino a la investigación metalúrgica en los aspectos que cada país necesita más, y en ese sentido todos más o menos ahora tenemos una idea de lo que está ocurriendo en distintos lugares y dónde sería conveniente enviar gente de un Instituto al otro por períodos que pueden ser cortos, largos, medianos, de acuerdo a lo que uno desee.

Hay un último punto en esto de entrenamiento de personal, es el que se refiere a entrenamiento de técnicos, de personal de operación. Esto se va a constituir cada vez más en el cuello de botella de las Instituciones que lleguen a trabajar en estado de régimen. Cuando una Institución comienza a operar no se nota demasiado la necesidad de contar con técnicos de operación debidamente entrenados. Cuando la Institución va a pasar a estado de régimen ése es uno de los cuellos de botella más fuerte, al extremo de que está agravado por el hecho de que así como existen alguna centena de posibilidades de beca de los organismos más raros, diversos y generales del mundo para preparar personal superior es decir PHD o ingenieros graduados o cosas por el estilo, es muy difícil, aparentemente, encontrar recursos o incluso lugares para el entrenamiento de técnicos.

Creo que en el entrenamiento de "technicians", si no se adopta una política desde ahora, nos va a dar dolores de cabeza dentro de 5 años como ya les da, por ejemplo, a los físicos. En latinoamérica se ha entrenado mucha gente en física, se dispone de excelentes laboratorios pero en este momento hay una escasez tan notoria de "technicians" capacitados, que es en verdad un ejército con generales y sin soldados. Llamo la atención para que no nos ocurra lo mismo a nosotros.

## 2. Utilización común, bilateral, o regional, de expertos extranjeros.

Recibimos de todos los países, corrientemente, metalurgistas de prestigio, que son caros, particularmente son caros de trasladar; una vez que han llegado a la Argentina muy poco costaría que hicieran una estada en el Uruguay o una estada en Chile o una estada en Sao Paulo, si esto se organizara con cuidado. Es decir, de obtener un poco más de beneficio no solamente de la capacidad técnica del hombre, sino también de sus experiencias, de su tradición, etc.

Esta política, nosotros, desde la Comisión, la hemos seguido muy conscientemente particularmente con los Institutos de Chile, Santiago, de Sao Paulo, que dirige el Dr. Correa da Silva, y también con el grupo de Córdoba. No siempre, pero generalmente la gente que invitamos nosotros, tratamos de que esté algunos días en Sao Paulo, otros días en Santiago y otros en Córdoba. Esto lo vamos a seguir haciendo, por supuesto, así de manera informal, no hay por qué firmar documentos para eso, basta con escribir unas líneas o hablar por teléfono, pero sería bueno escuchar otras ideas, conocer por ejemplo quién es la gente que va a



venir en el año 1965 al área. Nosotros vamos a traer el año que viene aproximadamente 10 metalurgistas, algunos de renombre tan grande como Bruce Chalmers, de Harvard, o Guinier, de Francia, o Dorn, de California, etc., pero sería muy bueno tener una lista "a priori" que permitiera entonces que las demás instituciones expresaran su interés en una determinada persona. Creo que esto sería simple de arreglar.

3. Intercambio de personal "senior" de las instituciones

Creo que debiéramos encontrar mecanismos que hicieran posible que una persona de nuestro laboratorio a nivel "senior" esté tres meses en un Instituto de Chile, o de Colombia, o de Perú, con el objeto de realizar un trabajo concreto. Eso lo va a llevar a un conocimiento más directo de lo que ocurre allí, particularmente al nivel de operación.

4. Temas concretos de investigación cooperativa

Habrán temas que puedan interesar a varios institutos. Yo he visto, por ejemplo, en esta reunión que es la preocupación de varios Institutos, el problema de arena de fundición. Un tema viejo, que a todos nos ha preocupado; en la Argentina se trabajó mucho en esto, hay una buena experiencia pero sería muy interesante probablemente, que dos o tres institutos del área tomaran el tema de arenas de fundición e hicieran un grupo de trabajo de operación concreto con un coordinador, pero un coordinador en algún lugar que convenga más y se haga un estudio sistemático.

La experiencia que está haciendo Chile, la que se ha hecho en la Argentina, la que se ha hecho en el IPT, la que está haciendo el Uruguay. Sería de tanta ayuda conocer, por ejemplo, nuestras materias primas, normalizar métodos, tratar de diseñar métodos propios. Por ejemplo, que el trabajo del Ing. Lo Ré tenía una idea central importante: un dilatómetro vale 15 mil dólares. Si el Ing. Lo Ré con su aparatito lo ha resuelto mejor o peor que con el dilatómetro, esto no me importa tanto, lo que importa es la inspiración que tuvo el Ing. Lo Ré.

Es muy común cuando no se tiene experiencia en investigación, comprar aparatos por catálogo y creer además que los aparatos funcionan más o menos solos. Alguien me dijo una vez que la imagen que en los países subdesarrollados se tiene de la investigación, es que la investigación consiste en comprar un aparato grande con muchos botones y uno apreta los botones y después salen las respuestas. Y si uno le une una computadora, se puede ir a su casa porque sale tabulado y casi impreso para la revista correspondiente.

Bueno, todo esto lo sabemos bien o simplemente lo cuento a título de que al tomar temas como el de arenas de fundición, donde hay un interés muy directo, los encaremos con criterio original.

Se pueden sugerir otros temas de interés también multilateral. Por ejemplo nosotros tenemos interés en electrodos para soldadura a punto para máquinas de soldar, creemos que es un tema que tiene interés para muchos otros más que nosotros, porque es un elemento que hay que usarlo y se va a usar cada vez más, donde por otra parte, la competencia, el know-how del exterior no es demasiado grande, digamos demasiado diferente, no estamos a distancias siderales del conocimiento. En el caso de electrodos aquí ha habido dos trabajos curiosamente sobre el mismo tema sin haber un acuerdo previo ni siquiera conocer el uno que lo iba a presentar el otro, que es el trabajo de Sao Paulo sobre electrodos y el nuestro sobre electrodos, lo que prueba que hay un problema común; no por casualidad nos hemos ocupado los dos de lo mismo.

#### 5. Para la financiación de los trabajos

Para la financiación de los trabajos que queremos realizar nosotros, en conjunto o individualmente, se dispone en los organismos internacionales generalmente, de una cierta cantidad de fondos con destino específico, como adiestramiento por ejemplo. Eso es necesario y debe ser utilizado. Pero yo creo que habría que hacer alguna presión orgánica sobre ciertos organismos en particular, para que además de entrenamiento destinen fondos para financiar trabajos de investigación y desarrollo.

Hay muy poca disponibilidad de lo que se llama "operating funds", fondos de operación. Es muy curioso ver que uno puede conseguir bastante dinero para "capital funds", pero esa es una trampa en la cual todos debiéramos tener mucho cuidado, porque hay que hacer el cálculo de cuánto se necesita de "operating funds" para cada dólar de "capital funds".

Obtener un préstamo de un millón de dólares para equipos y para expertos, supone un presupuesto de funcionamiento de 100 a 150.000 dólares anuales. De modo que antes de caer en la tentación de una máquina grande o de una instalación cara, analicemos muy cuidadosamente dónde van a estar los "operating funds", porque si no encontramos los "operating funds" ese peso del millón de dólares nos puede hundir, de esto hay ejemplos en toda América Latina de institutos con hermosos edificios y muy hermosos aparatos vacíos de toda actividad porque alguien se olvidó que los aparatos funcionan con gente y que hacen falta los cables, los termocuplas, etc.

#### 6. El problema de la evaluación de recursos humanos en metalurgia

El problema de la evaluación de recursos humanos en metalurgia en una proyección al 70-80 de nuestras necesidades. Creo que podríamos pedir estudios un poco específicos; proyección de recursos humanos y niveles de recursos humanos que va a demandar no la metalurgia en general, sino nuestra actividad en metalurgia.

UNCLASSIFIED

Security Classification

DOCUMENT CONTROL DATA - R & D

(Security classification of title, body of abstract and index information must be entered along with overall report classification)

1. ORIGINATING ACTIVITY (Corporate author) Argentine Comision Nacional de Energia Atomica Technical Assistance Services of the Metallurgy Indus. Buenos Aires, Argentina	2a. REPORT SECURITY CLASSIFICATION UNCLASSIFIED
2b. GROUP	

3. REPORT TITLE  
LATIN AMERICAN CONFERENCE ON [REDACTED] PROCESS METALLURGY AND METAL WORKING, 1st, Buenos Aires, 18-23 Aug. 1964, Volume I and II 1966

4. DESCRIPTIVE NOTES (Type of report and inclusive dates)  
Scientific Final

5. AUTHOR(S) (First name, middle initial, last name)  
Dr O Wortman and Others

6. REPORT DATE 4 October 1966	7a. TOTAL NO OF PAGES 827	7b. NO OF ILLS 463
----------------------------------	------------------------------	-----------------------

8a. CONTRACT OR GRANT NO AF-AFOSR-717-05	9. ORIGINATOR'S REPORT NUMBER(S)
b. PROJECT NO. 9761-01	
c. 61445014	10. OTHER REFERENCE NUM(S) (Any other numbers that may be assigned this report) <b>AFOSR 66-2001</b>
d. 681301	

10. DISTRIBUTION STATEMENT  
Distribution of this document is unlimited

11. SUPPLEMENTARY NOTES	12. SPONSORING MILITARY ACTIVITY Air Force Office of Scientific Research 1400 Wilson Boulevard (SRPS)
-------------------------	---

13. ABSTRACT  
This publication (2 volumes) contains all the works presented at the First Latin American Conference on Process Metallurgy and Metal Working, held in Buenos Aires, during August 18-23, 1964. It was organized by the Department of Metallurgy of the Argentine Atomic Energy Commission, with the co-sponsorship of the Department of Scientific Affairs of the Organization of American States, the Instituto Nacional de Tecnologia Industrial (INTI) (Argentina), and the United States Air Force Office of Scientific Research, being its aim to analyze the possibility of co-operation in the field of metallurgy research among Latin American Institutions- in order to develop a strategy elaborated from the study of the present state of Process Metallurgy in developed countries, the programs being held in Latin America and the Institutions' own needs.

UNCLASSIFIED

Security Classification

14	KEY WORDS	LINK A		LINK B		LINK C	
		ROLE	WT	ROLE	WT	ROLE	WT
	Metallurgy Ultra bigstrength Steels Metal Working Physical Metallurgy Engineering Materials Materials Metal Processing Aluminum Aluminum Alloys Steels						

UNCLASSIFIED