

Technical Report

AD 640 120

MECHANIZATION STUDY  
OF THE REFERENCE LIBRARY  
JOHNS HOPKINS UNIVERSITY  
APPLIED PHYSICS LABORATORY

Best Available Copy

## ABSTRACT

The Applied Physics Laboratory (APL) Reference Library uses IBM 7094 and 7040 computers to produce a quarterly list of serials holdings and a quarterly union list of serials, including APL's holdings and those of other participating libraries. The APL Document Library uses these computers to produce an accessions list, selective bibliographies in accordance with its SDI program, and reference or demand bibliographies as a result of search requests. The repertoire of programs used has been designated the Information Processing System.

## T A B L E O F C O N T E N T S

	<u>Page Number</u>
ABSTRACT	ii
INDEX OF FIGURES	vi
I. SUMMARY	1
II. MECHANIZATION	3
1. Chronology	3
2. Description of Processes--Reference Library	4
(1) Input Procedures for Master Serial Tape	4
(2) Outputs	5
3. Description of Processes--Document Library	6
(1) Daily Processes	7
(2) Biweekly Processes	10
(3) Information Retrieval System Output	14
(4) Comprehensive Literature Search Processes	18
(5) 20-Year Index of APL Reports	19
(6) Other Applications of the APL/IRS Package	19
4. Activities Being Planned or Developed for Mechanization-Reference Library	19
(1) Book Catalog	19
(2) Exciton Bibliography	20
(3) Translations	20
5. Activities Being Planned or Developed for Mechanization--Document Library	21

	<u>Page Number</u>
(1) Graphic Catalog and Computer Index	21
(2) Thesaurus	22
III. PROGRAM SYSTEM DATA	24
1. Files	24
2. Programs	25
IV. EQUIPMENT AND COSTS	32
1. Equipment	32
2. Costs and Time	34
BIBLIOGRAPHY	35

## A P P E N D I C E S

- A. ORGANIZATION CHART OF LIBRARY
- B. REFERENCE LIBRARY PROCESSING
- C. DOCUMENT LIBRARY PROCESSING
- D. GRAPHICS STORAGE AND RETRIEVAL
- E. THESAURUS SAMPLES
- F. EDIT PROGRAM
- G. PRINT PROGRAM

## INDEX OF FIGURES

<u>Figure</u>		<u>Page Number</u>
1.	Information Retrieval System--Daily Processing	8
2.	Information Retrieval System--Biweekly Processing	11
3.	Information Retrieval System Output	15
4.	Comprehensive Search Processing	17
5.	APL System 1	32

## I. SUMMARY

Mechanization at the Central Laboratory Library Group (CLB) at the Applied Physics Laboratory (APL) involves journal holdings, document accessions lists, an SDI listing, comprehensive searches, information retrieval, and the production of a union list of serials using the IBM 1401 and 7094 computers. Plans call for a storage and retrieval system for the graphics collection and a book catalog. Translations now being added to magnetic tape will be included in the book catalog.

The CLB consists of a Reference Library which services staff members with books, periodicals, and reference materials, and a Document Library, which provides staff members with unpublished literature--reports, specifications, visual aids, military handbooks, maps, and the like. In addition, there is a Translations and Bibliography Service as a staff function to the Librarian, who is also the CLB Group Supervisor. (For organization of the CLB, see Appendix A.)

The broad division of library services at APL into Document and Reference Libraries is prompted mainly by security reasons. The Reference Library has no security classified documents and,

herefore, is readily accessible to staff and visitors alike. The Document Library, on the other hand, has large holdings of classified material, and it is physically located apart from the Reference Library in a security closed area.

The Reference Library contains a total of 25,000 books, with an annual increase of 2,500 items. Periodical subscriptions number 750; there are 15,000 bound volumes. The Document Library collection consists of 140,000 classified and unclassified reports. The APL information retrieval system is comprised of 18,000 reports, with an annual increase of approximately 8,000.

Users are provided accessions lists, an SDI program, and xeroxed copies of journal articles. In addition, they may request literature searches, bibliographies, abstracts, and translations. Users, in most instances, visit the Reference Library but request from the Document Library through the preprinted request forms or the telephone.

Principal users of the Library are the scientists and engineers employed by the Laboratory. In addition, the Library has a large circulation through interlibrary loans that are made to government contractors and other scientific and technical libraries in the area.



## II. MECHANIZATION

### I. CHRONOLOGY

Documents were entered on the 1401 computer system beginning in March 1963. Also in 1963, the Laboratory acquired the IBM 7094 computer. Conversion of the information retrieval system from the 1401 to the 7094 was begun.

Early in 1964, the union list of serials became a reality, with plans developed and input complete enough for eight libraries so that the first listing was made in October. Also in the fall, the graphics collection became the responsibility of the Document Library, and development of a system to handle this collection began.

Beginning in January 1966, DoD, AEC, and NASA reports had one hard copy and one microfiche copy in file. A reports lifetime survey is being conducted and, when completed, should give some idea of when hard copies can be discarded.

## DESCRIPTION OF PROCESSES--REFERENCE LIBRARY

The Reference Library has, to the present time, limited its related activities to serial holdings, an exciton bibliography, a citations collection, and a List of Scientific-Technical Journals and Holdings in the Washington-Baltimore Area. The quarterly List of serial holdings is issued and routed to APL staff members from master tape. The List . . . . Area is produced irregularly, with assistance and cooperation of participating libraries who provide typed worksheets, punched cards, editing, and corrections for respective journal holdings. In return for their assistance, participating libraries receive a copy of the updated List when it is issued. The primary objective of this activity is to improve the ability of the Reference Library to serve the scientific staff members of APL.

### (1) Input Procedures for Master Serial Tape

1. Using the worksheet (see Appendix B-1), the periodical title, Library's code, and holdings (volume and year) are recorded for each title. Cross-references are included for titles that have changed.

2. Worksheets are then forwarded to the keypunch operator who produces the punched cards and forwards them to the Computer Center. From the cards, a printout is produced and returned to the Reference Library for editing.

3. The printout is checked, and correction cards are keypunched and sent to the Computer Center for addition to the Master Serials Tape.

(2) Outputs

1. Journal Titles and Holdings, APL Reference Library

Quarterly, the Master Serials Tape is searched for APL holdings, and a listing is made. This listing is routed to APL personnel and provides information on all titles currently held by the Reference Library as well as the volumes and years covered. The periodical title is followed (on the next line) by the volume number and the year in parentheses. An asterisk indicates missing issues. "Current Year" indicates that only issues of the current year are maintained as part of the collection. (For sample, see Appendix B-2.)

2. Union List of Scientific and Technical Journal Titles and Holdings in the Washington-Baltimore Area.

Issued irregularly, this publication currently provides titles and holdings for some 14 libraries in the Washington-Baltimore area. It is printed from the Master Serials Tape in the same format as the APL Reference Library listing. Alphabetic codes (limited to four letters) have been assigned various participating libraries, and the code precedes the holdings for that particular Library.

(See Appendix B-3 for a sample page.)

3. DESCRIPTION OF PROCESSES--DOCUMENT LIBRARY

The Document Library provides automated services to APL staff members in the areas of Selective Dissemination of Information; comprehensive literature searches; the APL Document Library Accessions Bulletin; the 20-Year Index of APL Reports, to be completed in cooperation with the Technical Reports Group at APL; and the Graphic Catalog and Computer Index.

(1) Daily Processes (See Figure 1)

1. Documents are received from Technical Processing. Prepunched accession number cards and classification cards are inserted inside each document's cover. Any special remarks for catalogers such as: (1) for Accessions Bulletin only, (2) for progress report file (progress reports are on separate tape), (3) classified title, or (4) no cataloging of any type are marked on these cards.

2. Documents are given to catalogers. The information retrieval system (IRS) input form (Appendix C-1) is prepared: accession number and classification are entered; abstract location and content in the document are indicated for keypunch operators; descriptors for authors, date of report, accession number, classification, source code, and contract number are entered. APL/IRS-modified COSATI headings are then assigned for field and group. The cataloger is then free to assign as many descriptors as he feels are necessary to describe and identify the particular report. Subject headings for the manual card catalog are then assigned. Finally, the cataloger dates and initials the preliminary input form.

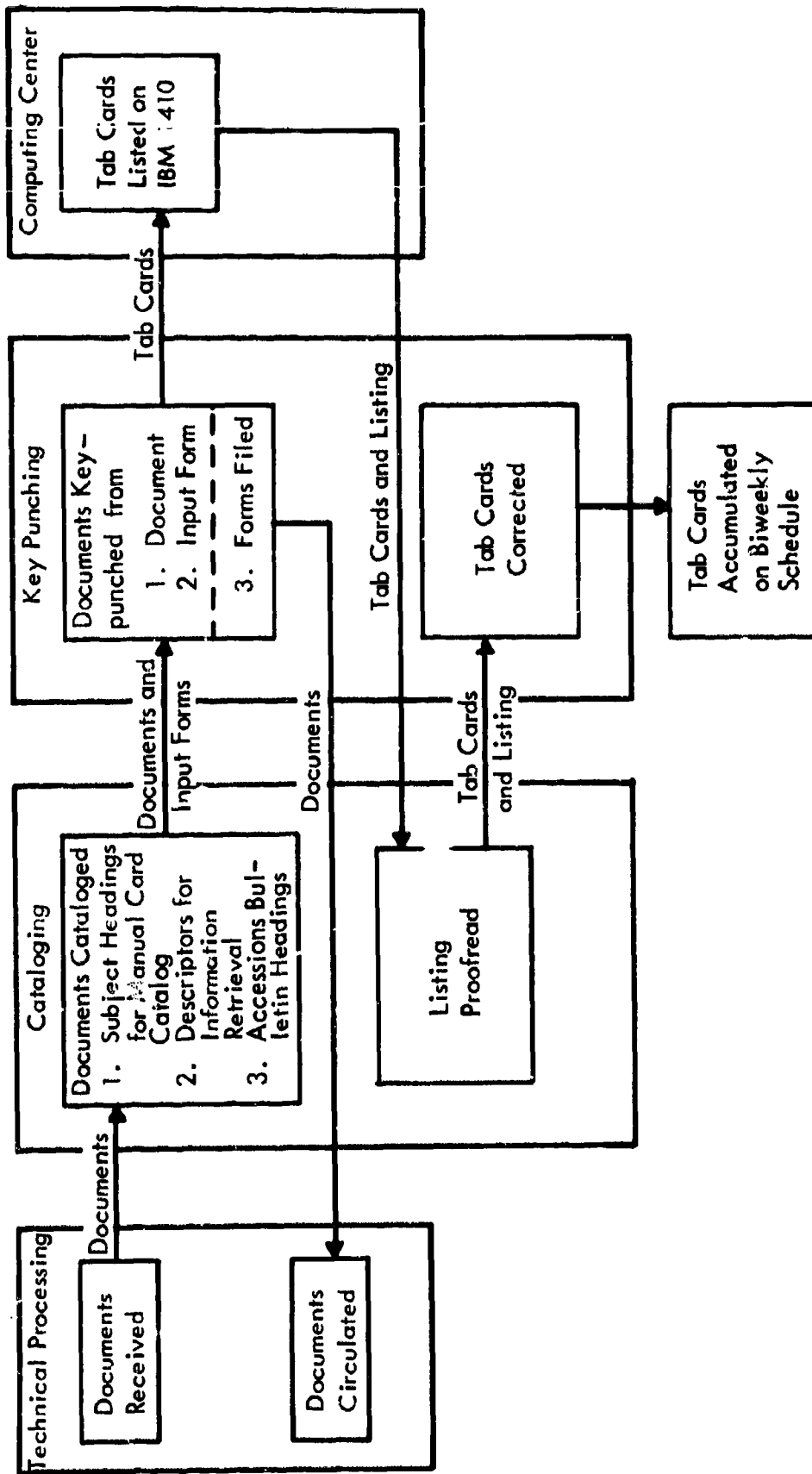

FIGURE 1  
Information Retrieval System--Daily Processing

3. The documents and forms are passed to the cataloger responsible for the Document Accessions Bulletin. At this point, the Accessions Bulletin heading is assigned, and the input forms are checked for consistency. (Those forms for which there is a major point of disagreement are returned, along with the document, to the catalogers for re-evaluation.) Documents and completed forms are returned to Technical Processing for catalog card production.

4. Documents and input forms are received by the key-punchers from Technical Processing when catalog cards are completed. Prepunched accession number card and classification card, input form, and document are checked to be sure no mixup has occurred. Prepunched cards are added manually to the new keypunched cards. The bibliographic information and indicated abstract are keypunched from the document. Descriptors are keypunched from the input form. Documents are returned to Technical Processing for circulation. At the end of the day, the daily accumulation of keypunched cards and the cards themselves are received from the Computer Center each morning. The listing is proofread by catalogers for content, spelling,

program signals (e. g. , asterisks for line breaks), descriptors, and Document Accessions Bulletin (DAB) headings.

6. The proofread listing and keypunched cards are forwarded to keypunch operators. Corrected cards are punched. Cards are then filed and held for input to magnetic tape.

(2) Biweekly Processes (See Figure 2)

1. Accumulated keypunched cards are taken to the Computer Center and listed on magnetic tape by an Edit Program. The output of this step is a preliminary work tape and a printout of records on that tape. The preliminary work tape is matched with an Alpha Comparison Program and an alphabetic descriptor tape. Descriptors on the work tape are compared with the alphabetic tape, and a list of nonstandard descriptors is given. (A second version of this step dispenses with the comparison and gives an alphabetic list of descriptors followed by the record number in which they appear.)



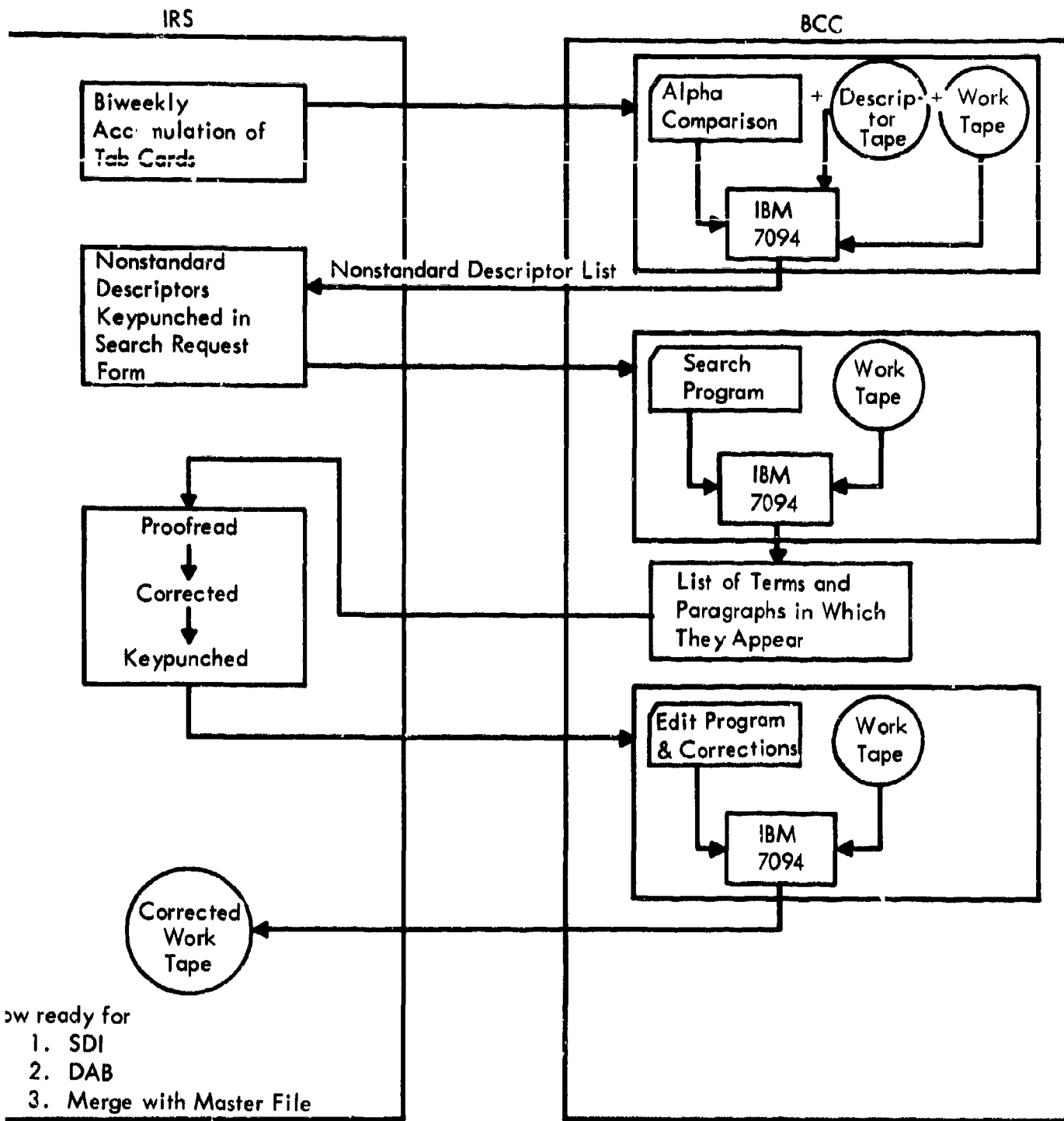

FIGURE 2

Information Retrieval System--Biweekly Processing

This set of jobs is put on the computer as one run. The output received is a preliminary work tape, a 100-character-per-line printout (see Appendix C-2), and an alphabetic list of standard descriptors.

In order to identify the location of errors on the 100-character-per-line printout, each line is divided into 10 columns of 10 spaces or characters, each numbered from 0 to 99 across the top and from top to bottom. This system permits the editor to locate the character number on the tape without tediously counting each character across the line to make a correction. Correction cards are then punched, indicating the location of the change and the change to be made, and the tape is revised accordingly.

For correction of descriptors, a simpler method is used. A card is punched containing the record number, the incorrect descriptor, and the substitution operator (SO) followed by the descriptor (i. e., \$160 = / RADAR / \$, SO, / RADAR /). The computer will then search for the indicated record on the tape and will make the correction.

2. The list of nonstandard descriptors is checked by the catalogers for misspellings, incorrect terms, and new words. The list is then given to the keypunch operators, who keypunch the terms in the form of search questions.

3. Search questions are added to a Search Program and are taken to the Computer Center along with the work tape. A search is then made for terms against the work tape descriptors. Output is a printout of each descriptor searched for, followed by the paragraph or paragraphs in which the descriptor appears.

4. Descriptors are then reviewed by the catalogers for corrections or additions to the thesaurus. Corrections are entered on coding forms and sent to keypunch operators. Additions to the thesaurus may be made at this time or may be held until future additions are ready.

5. Keypunched correction cards are added to the Edit program and are taken to the Computer Center along with the work tape. The preliminary work tape is then corrected. Output is a corrected work tape and a printout of the records in which corrections occurred.

6. The corrected work tape is now ready for SDI search, DAB search, and merging with the Master File.

) Information Retrieval System Output (See Figure 3)

1. Selective Dissemination of Information (SDI)

The SDI profile searches are run biweekly against the current corrected work tape. The output of the SDI search is a listing of the profile searches, a listing of hits per search, and a printout of the records satisfying each search. Each record contains the following bibliographic information: accession number, classification, source, report number, title, author, date, contract number, abstract (if available), and descriptors. The list of searches and the number of hits are filed. The printout is cut to page size, and pages are stamped with appropriate classification and bound with covers denoting the highest classification. Each search result is then circulated to the requester. Since the processing is done by a member of the IRS staff, the SDI results are circulated about two weeks prior to the circulation of the Document Accessions Bulletin.

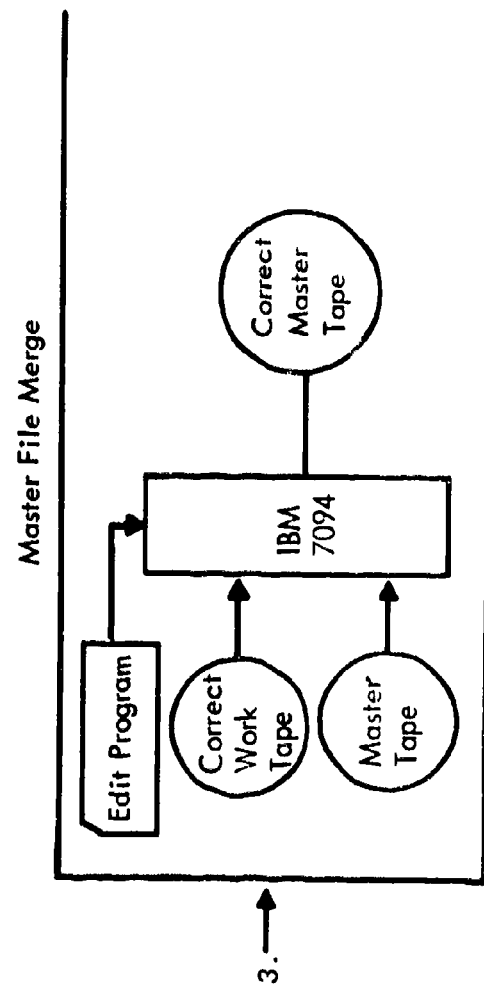
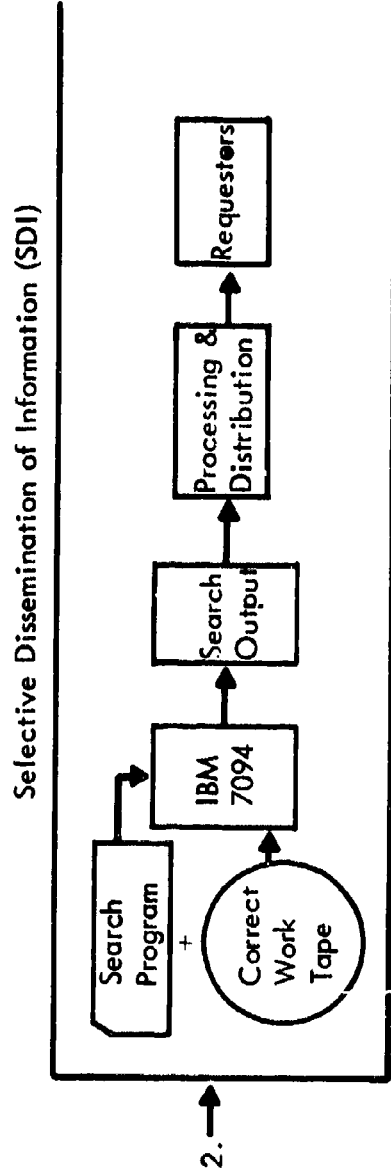
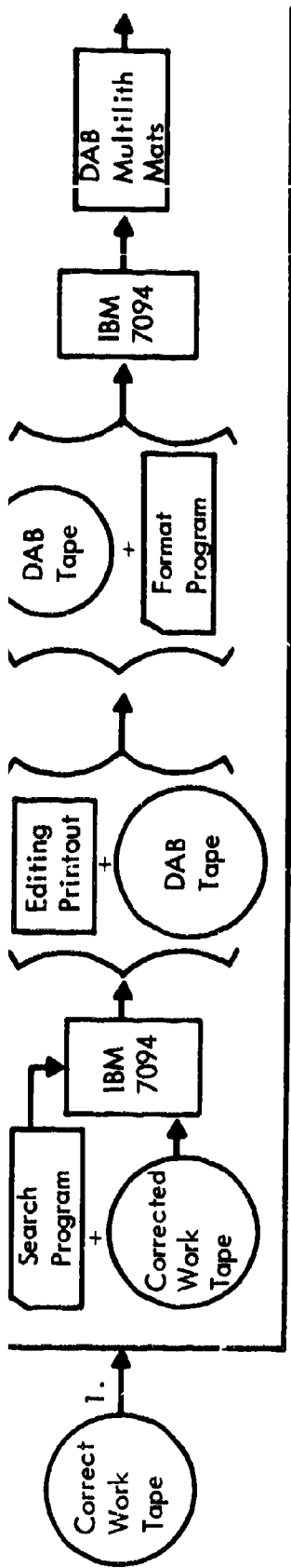

FIGURE 3  
Information Retrieval System  
Output

## 2. Document Accessions Bulletin

The DAB is arranged by APL/IRS-modified COSATI subject headings. (See Appendix C-3 for sample.) To obtain a tape with the records in subject heading order, a search is made against the current biweekly work tape, using the subject headings as searches. The tape received as output of this search is listed and visually scanned for formatting errors. If an error is found, corrections are made. The corrected DAB tape is then formatted, and the table of contents is created by a special formatting program and then printed on multilith mats. The major field headings are centered on the page with group headings in alphabetic order at the left margin. Under each heading are records containing accession number, classification, source, report number, title, author, and contract number. The table of contents lists field and group headings by page number. Document News and Notes are typed manually. All mats are sent to reproduction for circulation to the Technical Staff.

(4) Comprehensive Literature Search Processes (See Figure

A requester contacts one of the catalogers either by phone or by an office visit. The request is discussed until the cataloger feels that he knows what the requester wants. The cataloger writes the request in search language. (See Appendix C-4, C-5, and C-6 for example of search request form, query program coding sheet, and resulting punched card, respectively. See Appendix C-7 and C-8 for explanation of search logic.)

The search is combined with the Search Program, and Master File tapes are taken to the Computer Center at the end of the day. Computer runs are made at night. Output is received the next morning. The output is in three parts: (1) a list of searches (see Appendix C-9) and search question (see Appendix C-10), (2) a list giving number of hits per question (see Appendix C-11), and (3) a printout of records satisfying each search (see Appendix C-12). The printout is cut to page size, each page is stamped with the appropriate classification, and the request is bound and either distributed to the requester by the interoffice mail system or hand-carried if the cataloger wishes to discuss the results with the requester.

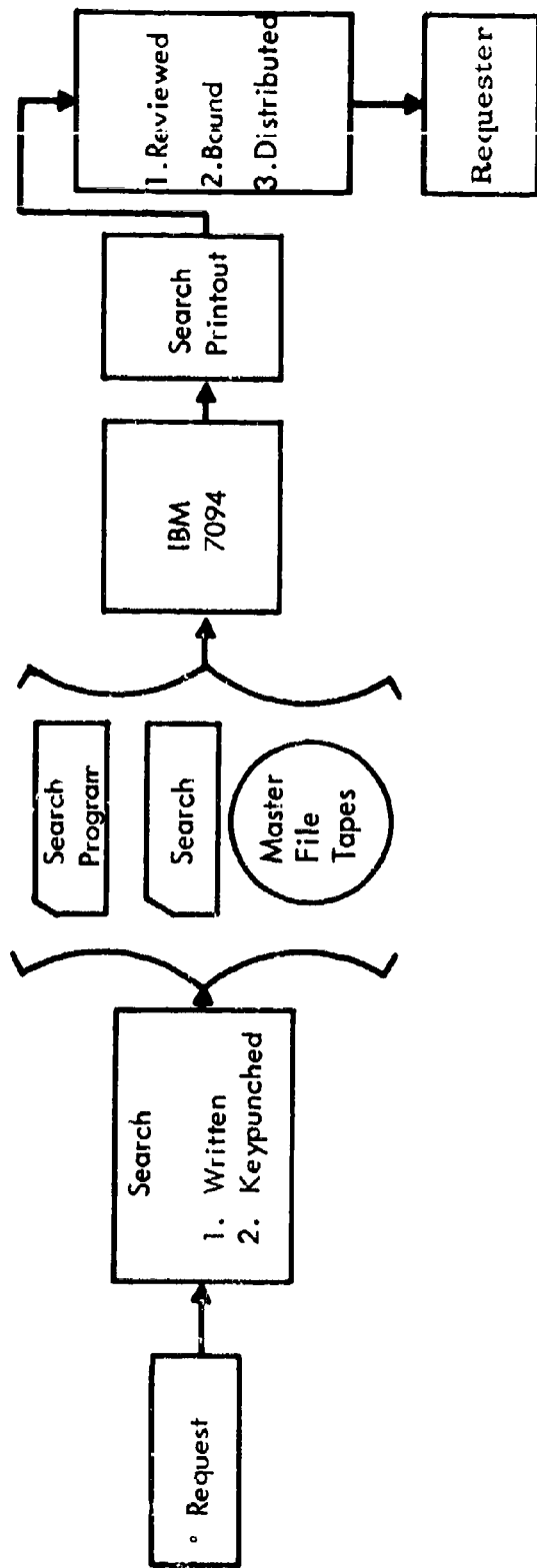

FIGURE 4  
Comprehensive Search Processing



(5) 20-Year Index of APL Reports

Internal reports indexes are now being keypunched. After the cards are keypunched and listings are edited, the records will be put on tape and a cumulative index will be printed out. According to present plans, annual supplements will be printed, and cumulations will be printed every five years. The indexes, which will be by author and subjects, will contain full bibliographic descriptions of the reports and will include abstracts.

(6) Other Applications of the APL/IRS Package

From time to time, the information retrieval package is used to solve other problems. The system has been adapted to hospital records, for example, and is currently being used to manipulate certain data that are not amenable to FORTRAN.

4. ACTIVITIES BEING PLANNED OR DEVELOPED FOR MECHANIZATION--REFERENCE LIBRARY

(1) Book Catalog

Experiments are being conducted to determine format for the book catalog. The Reference Library book catalog will contain some 30,000 items. It will consist of an author, subject, and title catalog. The first volume will be supplemented monthly.

Each monthly supplement will be cumulative; that is, the February supplement will include January's, March's will include both January's and February's, etc. Plans call for a book catalog in each office in which technical personnel are assigned. Discarding the card catalog in the main Library is not planned. However, the possibility of generating a new catalog is not being overlooked.

(2) Exciton Bibliography

Translations and Bibliography Service is currently entering all items concerning excitons to magnetic tape. This involves some 1,500 - 1,800 items and will be the basis for a continuing bibliography in this field. The information included for each reference contains author, title, journal title, volume, pagination, year, abstract, bibliographic descriptors for retrieval, and subject descriptors for indexing.

(3) Translations

Applied Physics Laboratory has approximately 2,000 individual translations in its collection. This task served as a pilot study to establish procedures and format for the book catalog. Tentative programs have been written to produce author, subject, and title catalogs. It is also possible to produce listings based

on report number, accession number, journal of publication, etc.  
Translations are being continually added.

5. ACTIVITIES BEING PLANNED OR DEVELOPED FOR  
MECHANIZATION--DOCUMENT LIBRARY

(1) Graphic Catalog and Computer Index

The Document Library has been given the responsibility of maintaining the visual aids file. A system has been developed and tested to index this material. Previously, a manual system using 5x8 cards (see Appendix D-1) provided the only control over this material. Punched cards are now used to prepare indexes for the collection and to serve as a manual card catalog.

The card contains space for the visual aid number, revision, classification, date, black and white negative indicator, color negative indicator, vu-graph, print and glossy photograph indicators, presentation number, originator's designation and number, title, subjects for the subject catalog, and remarks. The card also carries a Xerox reproduction of the visual aid. The blocks on the lower lefthand corner of the tab card are marked with X's by the Document Library to show the existing backup material and whether it is in black and white or in color. Blocks are also provided to show the two possible sizes for slides;

whether glossy photographs, prints, or vu-graphs exist; and the size of the original chart. The last blocks are for flip charts. (See Appendix D-2.)

This information will be transferred to magnetic tape, and indexes will then be generated by visual aid number, by originator, by black and white negative number, color negative number, and the like. A sample printout of these indexes is shown in Appendix D-3. Each originator will receive copies of the punched cards, and there will be copies in the Document Library for three or four subjects and visual aid numbers. Each contributor will receive a copy of the index.

(2) Thesaurus

An indexing handbook and thesaurus is being developed and is presently about one-third complete. When a concentrated effort was begun on this project in June 1965, terms already in the system represented a free vocabulary. Terms already in use were reviewed for inclusion in the thesaurus.

The thesaurus will contain two sections and two appendices. The first section will contain an alphabetical listing of terms, including their meanings, synonyms, use information (do not use,

use also, etc. ), and related terms (see Appendix E-1). The second section will contain the field structures, which is an expanded COSATI listing of categories. Thirty-five fields are provided, and each field is arranged into groups. The groups contain the pertinent descriptors plus related references and terms.

The first appendix will contain a list of abbreviations and rules and regulations for translating noncomputer characters. The second appendix contains the sources and their codes arranged in two ways--sources against codes and codes against sources (see Appendix E-2 and E-3).

### III. PROGRAM SYSTEM DATA

The APL repertoire of programs has been designated the Information Processing System (IPS). It consists of programs written for the IBM 7094 computer which are run under the APLSOS monitor system. The main emphasis in IPS is on the processing of nonnumerical data.

The IPS consists of five programs. Three of the programs are written in machine language: Search, Sort, and Manipulator. The two additional programs, Edit and Print, are written in Manipulator language.

#### 1. FILES

The standard file format assumed by most programs of IPS consists of any number of records, from zero to as many as the tape will hold or until the end of file is reached. The last record of the file is followed by a tape mark. Normally, a single file is kept on a single tape. Some programs of IPS have provisions for handling multiple files and multiple tapes, but such provisions are not standard.

Each standard record consists of at least nine and at most 10,000 characters. The first five characters of each record are decimal digits and generally represent a sequential record number. Characters 6 and 7 are used for printer format control. The last character of each record is a dollar sign. For Document Library application, the intervening characters (up to 9,992) are normally blocked into three fields consisting of fixed field, free text field, and descriptor field. There are only two restrictions imposed on the use of allowable characters. The virgule (/) is used to separate descriptors and cannot be used for any other purpose if the file is to be searched. The dollar sign, generally reserved for system use (i. e. , search operators), may occur in a record but not as part of a descriptor.

Programs written in manipulator language may assume any file format desired. However, if such programs produce a file to be used by the other programs, they must conform to the above format.

## 2. PROGRAMS

### (1) Search

The Search Program is designed to examine one or more magnetic tape files, in standard IPS format, and record on a new file those records which satisfy at least one search request.

(See Appendix C-8 for more details.) The program accepts as input a deck of cards specifying the requests for information plus a file or files suspected of containing the desired information. The search is made by looking for logical or positional combinations of descriptors, as specified by the search request, in each record of the input file(s).

The search technique is based on the use of three logical operators: AND (\$A), OR (\$O), and NOT (\$N), and five magnitude operators: EQUAL (\$E), LESS THAN OR EQUAL TO (\$L), GREATER THAN OR EQUAL TO (\$G), NUMERICAL (\$n), and SELECTIVE NUMERICAL (\$I, J). The use of these operators is explained in detail in Appendices C-7 and C-8. Each request is written in Polish Prefix Notation (i. e. , all operators to the left and words to the right). The request may contain any legal combination of the operators and descriptors, as complex as desired and nested to any depth. For example, the simple request \$O\$A/X/Y/Z/ selects items having either the descriptors /X/ and /Y/ or the descriptor /Z/. Thus, by combining any or all of the operators with the descriptors, a very specific search may be made.



The output is one file tape, in standard file format, containing each request followed immediately by those records which satisfy that request. A listing of the search requests is also provided plus a summary table indicating--for each request--the maximum number of records to be printed (as specified by the search request) as well as the actual number of hits obtained (see Appendix C-11). The output tape will normally contain four records for each request. These records are: Format Record, New Page Number Record, Search Request Record, and Page Eject Record. Records 1, 2, and 4 are used as control records by the Print Program in listing the output.

(2) Sort

The Sort Program performs a tape sort of one file of data contained on one tape. (See Appendix C-8 for more details.) The process is a split-merge. The original file of data is sorted internally into substrings and split onto two tapes. These two tapes are then merged onto two others and so on, until the merging produces one string on one tape.

The program accepts as input a tape to be sorted plus four scratch tapes and a data card specifying control information such as sort key position and length, sort code, etc. One of the

atch tapes, as specified by the user, will contain the sorted  
out. The items (i. e. records) of the tape may be of variable  
gth, as only the maximum length is required to be known. The  
to be sorted on may be any length and may begin at any posi-  
i in an item. However, it must be the same length in each  
n and must begin at the same position.

### Manipulator

The Manipulator language is an IPS language designed,  
ically, for the manipulation of strings of characters. The  
nipulator Program consists of two parts, the compiler and  
executer. The compiler performs a one-pass compilation  
eeping as an input cards written in Manipulator format and  
guage, and produces as an output an interpretive code. The  
ecuter accepts as an input the interpretive code generated by  
compiler and performs the operations indicated by the code.

The Manipulator language consists of instructions which  
ow the user to specify the particular information-processing  
cedure to be carried out. The repertoire of instructions  
ows for:

- General Input/Output--tape reading and writing, on-  
line and off-line printing, and off-line card reading.

- . String Moving--both character and bit strings. Character strings may be converted automatically to other characters.
- . Character String Scanning--for categories of characters as well as strings of characters, both left and right.
- . String Comparison--both character and bit strings.
- . Numerical Operations--basic numerical operations on converted data as well as some functions (i. e. sine, cosine).
- . Automatic Loop Control.

The Manipulator program and language are explained in detail in Applied Physics Laboratory documents BCC-340 and BCC-375.

(4) Edit

The Edit Program (see Appendix F for detail) is designed to establish (card-to-tape conversion) and maintain files of information. It accepts as input a deck of cards, called the change deck, which specifies what is to be done during the run, and a file (which may be empty if it is an initial run). Also, two files may be merged during a run.

The change deck consists of control cards plus text cards. The control cards specify the type of change being made, such as replacement or inclusion of a new item. The text cards contain the new information being entered in the file.

Some of the features made available by the Edit Program are:

- . Replacement of a string of characters by another string whenever it occurs in the file or in any subset of the file.
- . Replacement of a string of characters contained in certain bounds, where the bounds may be specified as strings of characters or character position in an item.
- . Inclusion of new items in a file. This is used to establish the file initially as well as to update it.

(5) Print

The Print Program (see Appendix G for detail) prints a file of information or any collection of subsets of a file in a variety of formats as specified by the user. The program accepts as input a file containing the information to be printed plus format parameter cards which, together with the two format control characters in position 6-7 of each record, specify the format. The program deck must be followed by a parameter card for each file on the tape. If listings of the same file in more than

one format are desired, then a parameter card must be included for each format. Only parameters which are to be changed from their values for the preceding file need to be put on the parameter card. If no changes are required, the parameter card will be blank but must still be included.

The user has control of what information is to be printed from each item in the file. However, the information from each item must be a continuous string. Also, the user may specify the margins for the first line of each item and for all other lines. For example, indented or overhanging paragraphs may be produced. In addition, the user has control of line breaks as well as pagination, such as causing the page to be ejected if there is insufficient room for an item on that page. For example, tables may be made always to print on a separate page or at least not be broken from one page to the next. Also, page headings, numbering, etc., are at the control of the user if he desires.

#### IV. EQUIPMENT AND COSTS

##### 1. EQUIPMENT

The information retrieval system and its associated operations utilize System 1 of the Laboratory. System 1 is depicted in Figure 5.

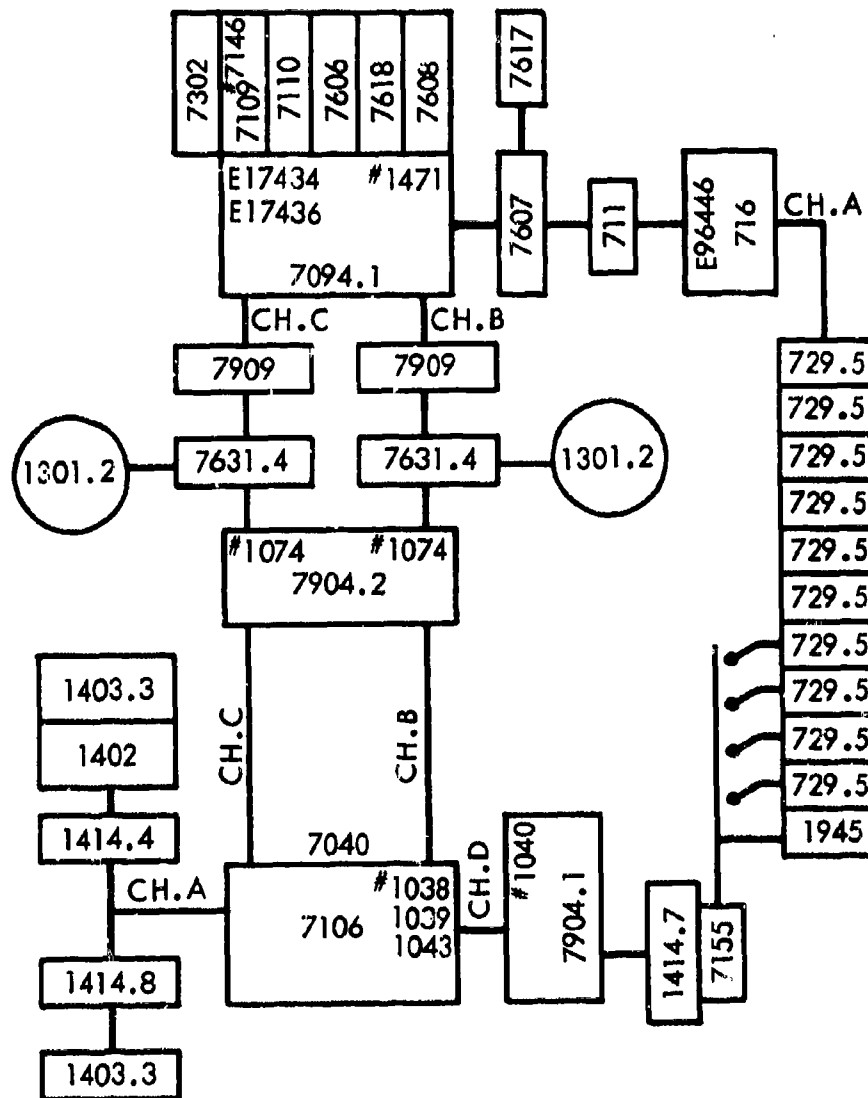

FIGURE 5  
APL System 1

IBM 7094

This system is used on line for the updating of the master file and processing of reference searches.

	7094	Mod 1 (7302 core storage unit)
	711	card reader
	716	printer
10	729	Mod 5 tape units; 4 shared with 7040
	7607	data channel (for reader, printer, tapes)
	7617	data channel control
2	7909	data channel (for disk storage)
2	1301	Mod 2 disk storage; shared with 7040
2	7631	Mod 4 file control; shared with 7040

IBM 7040

This system is used for card-to-tape conversions and preparation of printouts in support of the 7094.

	7040	(7106 processing unit)
4	729	Mod 5 tape units; shared with 7094
	7904	Mod 2 data channel (for disk storage)
2	1301	Mod 2 disk storage; shared with 7094
2	7631	Mod 4 file control; shared with 7094
	7904	Mod 1 data channel (for tape units)
	1414	Mod 7 input/output synchronizer (for tape units)
	1402	card reader/punch
2	1403	Mod 3 printer
2	1414	Mod 4 and Mod 8 input/output synchronizers

Additional equipment, which is located in the Library area, includes the following:

3	IBM 026 printing keypunch (leased)
1	Remington-Rand synchrotape (purchased)

2. COSTS AND TIME

Monthly equipment costs are:

026 keypunch (3 at \$67/mo)	\$ 201.00
7094/7040 computer system (average 11.5 hr/mo at \$465/hr)	<u>5,348.00</u>
<u>Total</u>	\$5,549.00

The three 026 keypunches combined are used approximately 16 hours per day. The 7094/7040 system is used on an average of 11.5 hours per month; however, only 6.5 hours are attributable to searches. The rest is used for file maintenance. The number of search questions per month presently average 250, with 200 of these in support of the SDI program and 50 attributable to comprehensive searches. The number of documents put on tape per month are presently averaging 650.

The comprehensive search requests require on the average of one-half hour for the library processing of the question. The time is divided as follows:

15-20 minutes of discussion per question

10 minutes to write the question and keypunch it.



## B I B L I O G R A P H Y

Manipulator Program, M. L. Douglas, J. E. Peebles, and R. P. Rich, Applied Physics Laboratory document BCC-340, 18 June 1965, Applied Physics Laboratory, Silver Spring, Maryland.

7094 Edit Program, R. P. Rich, Applied Physics Laboratory document BCC-345, 28 October 1965, Applied Physics Laboratory, Silver Spring, Maryland.

Information Processing System, J. E. Peebles, Applied Physics Laboratory document BCC-351, 13 October 1965, Applied Physics Laboratory, Silver Spring, Maryland.

7094 Print Program, R. P. Rich, Applied Physics Laboratory document BCC-352, 27 October 1965, Applied Physics Laboratory, Silver Spring, Maryland.

7094 Search Program-7094 Sort Program, J. E. Peebles, Applied Physics Laboratory document BCC-359, 6 October 1965, Applied Physics Laboratory, Silver Spring, Maryland.

Manipulator Primer, R. P. Rich, Applied Physics Laboratory document BCC-375, 27 September 1965, Applied Physics Laboratory, Silver Spring, Maryland.

The Applications of Computers to the APL Storage and Retrieval System, F. L. Kennedy and M. E. Brown, Applied Physics Laboratory document TG-669, March 1965, Applied Physics Laboratory, Silver Spring, Maryland.

**APPENDIX A**

**ORGANIZATION CHART OF THE CENTRAL LABORATORY  
LIBRARY GROUP**

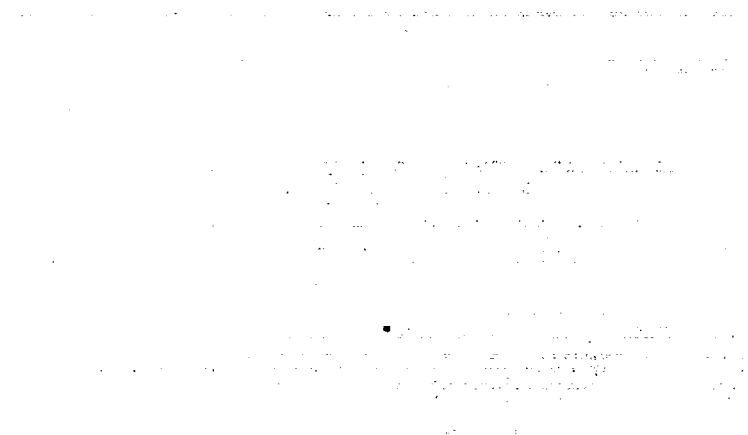

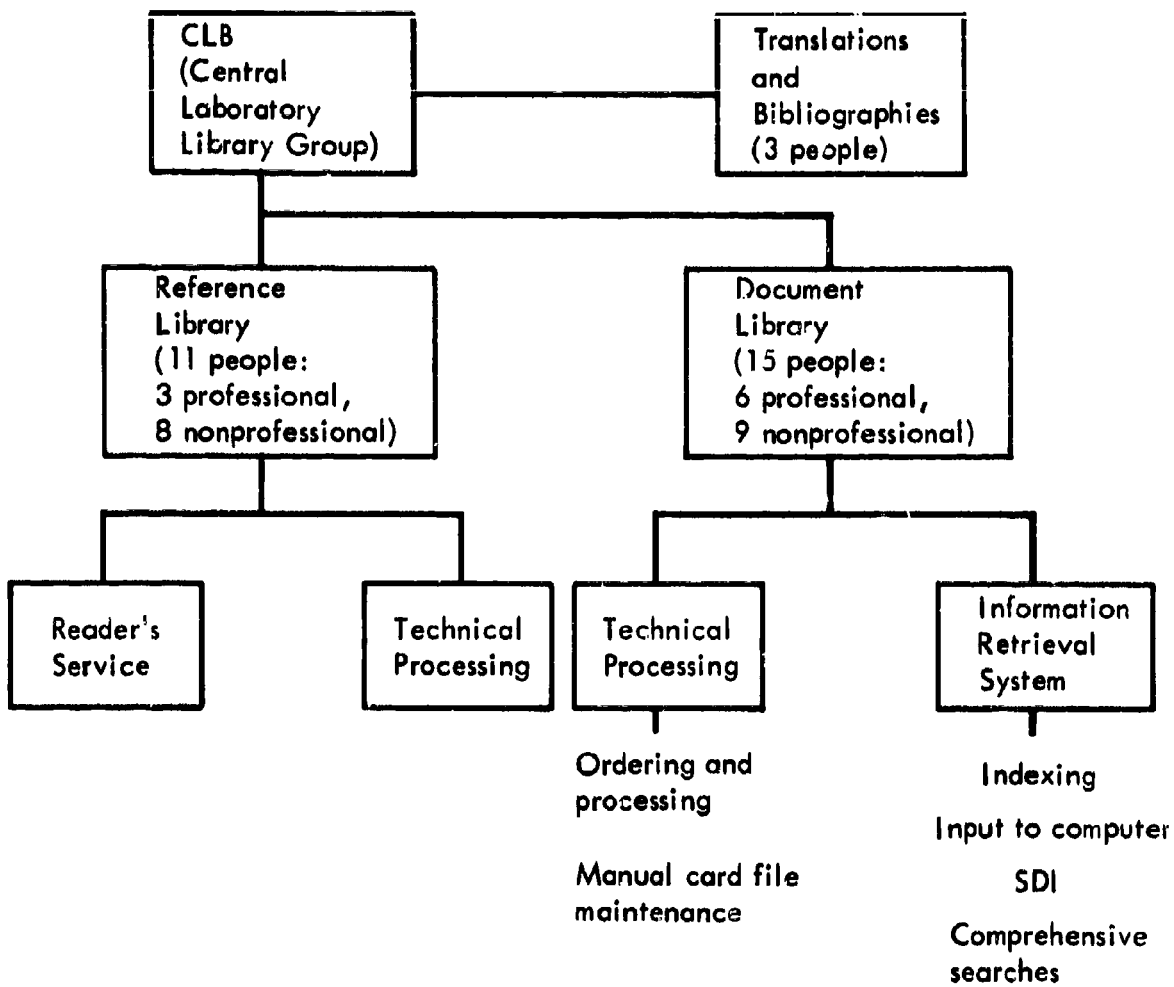

Applied Physics Laboratory Technical Library

**APPENDIX B**

**REFERENCE LIBRARY PROCESSING**

*[Faint, illegible text, likely bleed-through from the reverse side of the page]*



APL Reference Library Serials Listing

Sample

MATHEMATICAL ENGINEERING REVIEW (SEE AEROSPACE ENGINEERING)  
APL 2 (1942) - 17 (1958)

MATHEMATICAL QUARTERLY  
APL 2 (1949) TO DATE

MATHEMATICS (FUNCT 1962)  
APL 21 (1949) - 45 (1962)

PLANE AND COMMERCIAL AVIATION NEWS  
APL CURRENT YEAR

SPACE ENGINEERING (FORMERLY AERONAUTICAL ENGINEERING REVIEW)  
AERONAUTICS AND AEROSPACE ENGINEERING)  
APL 17 (1958) - 21 (1962)

APL 1958

TECHNICA  
APL 31 (1951) - 34 (1954)

BULLETIN (AMERICAN INSTITUTE OF AERONAUTICS AND ASTRONAUTICS)  
APL 1 (1954) TO DATE

JOURNAL (AMERICAN INSTITUTE OF AERONAUTICS AND ASTRONAUTICS)  
EARLY ARS JOURNAL, JOURNAL OF AEROSPACE SCIENCES, JET PROPUL-  
SION, AMERICAN ROCKET SOCIETY JOURNAL  
APL 1 (1953) TO DATE

JOURNAL (AMERICAN INSTITUTE OF CHEMICAL ENGINEERS)  
APL 1 (1955) TO DATE \*

UNIVERSITY PERIODICAL INDEX  
APL 9 (1956) - 11 (1960)

UNIVERSITY QUARTERLY REVIEW  
APL 1 (1947) - 8 (1956)

WAPT ENGINEERING  
APL 21 (1949) - 29 (1957), CURRENT YEAR

VEŠTA NAUK AZERBAJIDZHANSKOI SSR, TRUDY INSTITUTA MATEMATIKI I  
FIZIKI  
APL CURRENT YEAR

VEŠTA NAUK SSSR, DOKLADY  
APL 1 (1955) TO DATE

VEŠTA NAUK SSSR, TRUDY VYCHISLITEL'NOGO TSENTRA  
APL CURRENT YEAR

Union List of Serials  
Sample

43

ABSTRACTS OF BACTERIOLOGY

NR 1 (1917) - 9 (1925)

ACADEMIA SINICA, INSTITUTE OF ZOOLOGY, BULLETIN

NR 1 (1952) TO DATE

ACADEMIE DES SCIENCES, PARIS, COMPTES RENDUS

APL 224 (1947) TO DATE

NR 226 (1948)\* TO DATE

ACADEMY OF MANAGEMENT JOURNAL

IBM 4 (1961) TO DATE \*

ACADEMY OF SCIENCES, USSR, BULLETIN, DIVISION CHEMICAL SCIENCES

APL (1950) TO DATE

ACADEMY OF SCIENCES, USSR, BULLETIN, GEOPHYSICS SERIES

APL 1 (1957) TO DATE

ACADEMY OF SCIENCES, USSR, BULLETIN, PHYSICAL SERIES

APL 18\*-20\*, 21 (1957) TO DATE

ACADEMY OF SCIENCES, USSR, PROCEEDINGS, APPLIED PHYSICS SECTION  
(NOW SOVIET PHYSICS - DOKLADY)

APL 112-117 (1957)

ACADEMY OF SCIENCES, USSR, PROCEEDINGS, CHEMISTRY SECTION (DISCONTINUED 1961)

APL 118 (1958) - 141 (1961)

ACADEMY OF SCIENCES, USSR, PROCEEDINGS, PHYSICAL CHEMISTRY SECTION

APL 118 (1950) TO DATE

AGRO AND ENERGIA

BAAR 14 (1957) - 15 (1958)

ACOUSTICAL SOCIETY OF AMERICA JOURNAL

APL 1 (1929) TO DATE

ARC 21 (1949) TO DATE

CNA 36 (1964) TO DATE

ISA 31 (1959) TO DATE \*

NR 17 (1945) TO DATE

ACTA BIOCHIMICA POLONICA

NR 8 (1961)\* TO DATE

ACTA MATHEMATICA

APL 111 (1964) TO DATE

**APPENDIX C**

**DOCUMENT LIBRARY PROCESSING**





1	2	3	4	5	6	7	8	9	0
1234567890	1234567890	1234567890	1234567890	1234567890	1234567890	1234567890	1234567890	1234567890	1234567890
0	1	2	3	4	5	6	7	8	9
0000	745 UNCLASS	UNIV OF	SOUTHAPTO N.	ENGLAN D.	R-143.	ARL-TN-6	O-178.	RE COMBINATIO	N OF OXYGE
1	N IN A NOZ	ZLE--COMPA	RISON WITH	EXPERIFER	TAL RESULT	S FOR AIR	FROM GENER	AL ELECTRI	C RESEARCH
2	Y. 27P.	SEP 1960.	/BRAPAKIN	/1960/YEAR	/745557ACC	/U/IDEAL/G	AS/DISSOCI	ATION/HYFE	RSOHC/MOZ
3	IR/ATOMIC/	RECOMBINAT	ION/OXYGEN	/RECOMBINA	TION/AEROD	YNANIC/HEA	TING/HYPER	SONIC/FLOW	/GAS/FLOW/
4	/GAS/DYNAM	IC/FLUID/M	ECHANIC/NO	NEQUILIBRI	UM/FLOW/RE	SULTS ARE	PRESENTED	FROM CALCU	LATIONS ON
5	TS OF ATOM	IC RECOMBI	NATION ON	THE FLOW O	F AN IDEAL	GISSOCIAT	ING GAS TH	ROUGH A HY	PERSONIC N
6	ESE RESULT	S ARE COMP	ARE WITH	DATA FROM	SHOCK TUBE	WIND TUNN	EL EXPERIM	ENTS ON AT	R PUBLISHE
7	GENERAL ELE	CTRIC RESE	ARCH LABDR	ATORY FOR	SIMILAR CO	NDITIONS.	QUALITATI	VE AGREERE	NT IS FOUN
8	THE THEORE	TICAL AND	EXPERIMENT	AL RESULT	S.				

Sample of an editing printout, showing numbered spaces and lines for the convenience of an editor.

ACOUSTICS

Accessions Bulletin  
Sample

100000

CONFIDENTIAL

DEPT. OF THE NAVY; U.S. NAVAL ORDNANCE LABORATORY, WHITE  
OAK, MD. RPT. ONR-34-2500

ARMY RESEARCH DEPARTMENT - 1964, BY Y. F. JOHNSTON. 31  
DECEMBER 1964.

ALUMINUM

101000

UNCLASSIFIED

ALUMINUM COMPANY OF AMERICA, ALCOA RESEARCH LABORATORIES,  
PHILADELPHIA, PENNSYLVANIA. RPT. QR- 3 SEP 64-3 DEC 64,  
NO. 453733.

FRACURE TOUGHNESS, FATIGUE-CRACK PROPAGATION AND CORROSION  
CHARACTERISTICS OF ALUMINUM ALLOY PLATES FOR WING SKINS, BY  
G.E. NORDMARK, B.W. LIFKA AND J.G. KAUFMAN., PER. COV. 3  
SEPT 64-3 DEC 64., AF-33(657)-1155, AF-33(615)-2012.

102040

CONFIDENTIAL - RESTRICTED DATA

PRATT & WHITNEY AIRCRAFT, DIVISION OF UNITED AIRCRAFT COR-  
PORATION, MIDDLETOWN, CONNECTICUT., RPT. PMAC-1019.

ADVANCED MATERIALS PROGRAM FOR JANUARY AND FEBRUARY-1965.,  
APRIL 7, 1965., AT(30-1)-2789.

Sample

... STRENGTH LABORATORY, WHITE

... - 1964, BY T. F. JOHNSTON, 31

... RESEARCH LABORATORIES,

... CR- 3 SEP 64-3 DEC 64,

... PROPAGATION AND CORROSION  
... PLATES FOR WING SKINS, BY  
... KAUFMAN., PER. COV. 3  
... AF-33(615)-2012.

CONFIDENTIAL - RESTRICTED DATA

... DIVISION OF UNITED AIRCRAFT COR-  
... CONNECTICUT., RPT. PWAC-1019.

... PROGRAM FOR JANUARY AND FEBRUARY 1965.,  
... 1965., ATSC-1-1789.

THE JOHNS HOPKINS UNIVERSITY  
APPLIED PHYSICS LABORATORY  
DOCUMENT LIBRARY

INFORMATION RETRIEVAL SYSTEM  
SEARCH REQUEST FORM

REQUESTOR: FA... DATE REQUESTED: \_\_\_\_\_

GROUP: FIN EXT: 3 DATE REQUIRED: \_\_\_\_\_

CLASSIFICATION: (U) C S C-RD S-RD (CIRCLE HIGHEST)

SEARCH REQUEST

TOPIC: ...

FIELD:

A. MAJOR: ...

B. RELATED: \_\_\_\_\_

SYNONYMS: \_\_\_\_\_

SEARCH: \_\_\_\_\_ DATE: \_\_\_\_\_

I.B. If you know the author or organization please write it down.  
Synonyms for either the major phrases or words greatly increase the  
scope of the search.

*FOR REMARKS		OPERATION		ADDRESS, TAG, DECREMENT COUNT		COMMENTS	
LOCATION							
1	2	3	4	5	6	7	8
9	10	11	12	13	14	15	16
17	18	19	20	21	22	23	24
25	26	27	28	29	30	31	32
33	34	35	36	37	38	39	40
41	42	43	44	45	46	47	48
49	50	51	52	53	54	55	56
57	58	59	60	61	62	63	64
65	66	67	68	69	70	71	72
73	74	75	76	77	78	79	80
81	82	83	84	85	86	87	88
89	90	91	92	93	94	95	96
97	98	99	100				

H-2 3, 100, F.K. HILL \* \$AFA/COMPRESSIBLE/BOUNDARY LAYER

Prepared by: [illegible]  
 \*FOR REMARKS LABORATORY



## SEARCH TECHNIQUE

The search technique used for the 7094 is based on the use of three logical operators and five magnitude operators, which are used with Polish Prefix Notation (i. e. , all the operators to the left, and the words to the right).

Logical Operators

\$A - AND

\$O - OR

\$N - NOT

Magnitude Operators

\$E - EQUAL

\$G - GREATER THAN OR  
EQUAL TO\$L - LESS THAN OR  
EQUAL TO

\$n - NUMERICAL

\$I, J - SELECTIVE NUMERI-  
CAL

By combining these operators with the descriptors, searches can be made more specific. The selection of descriptors and the use of the magnitude operator EQUAL tend to reduce the number of false drops (incorrect answers). The IBM 7094 as programmed will search out, compare, and accept descriptors individually as uniterms. However,



if the descriptors are bound together by the EQUAL operator, as phrases in the search, the computer will accept these descriptors if they are in the same sequence. This technique prevents the acceptance of descriptors used in another context.

As an example, assume that a request is received by the librarian for information on "Underwater Detection Systems." Two documents may have these three descriptors listed on the tape but used in entirely different contexts. The first document might have the descriptors

/UNDERWATER/COMMUNICATION/SYSTEM/...../GAS/

DETECTION whereas a second document might have

/UNDER/DETECTION/SYSTEM/.

If the tape is searched by the single descriptors (uniterms)

/UNDERWATER/and/DETECTION/and/SYSTEM/

both documents will be accepted by the computer. The first document is obviously an incorrect answer. In the APL program, however, when /UNDERWATER/, /DETECTION/, and /SYSTEM/ are combined in the search by the EQUAL operator as follows:

\$A\$E/UNDERWATER/DETECTION\$E/DETECTION/SYSTEM/.

the IBM 7094 will accept the descriptors only when they are adjacent as in the phrase, "Underwater Detection System."

Another request might be for information on, "High temperature or heat resistant material but no aircraft material." The question would be phrased by the librarian in search language as follows:

\$A\$A\$O\$E/ HI/TEMP\$EHEAT/RESISTANT/MATERIAL\$N/AIR-  
CRAFT/

The search is built up with Polish Notation in the following manner:

1. "High" and "Temperature" are combined by the EQUAL Operator.

\$E/ HI/TEMP/

2. "Heat" and "Resistant" are combined by the EQUAL Operator and the logical operator OR is added to allow a choice of the two combinations.

\$O\$E/ HI/TEMP\$E/HEAT/RESISTANT/

3. The logical operator AND is added because "Materials" is also wanted.

\$A\$O\$E/ HI/TEMP\$E/HEAT/RESISTANT/MATERIAL./

4. The logical operators AND and NOT are added so that the computer will not accept documents with the descriptor "Aircraft".

\$A\$A\$O\$A/III/TEMP\$E/HEAT/RESISTANT/  
MATERIAL\$N/AIRCRAFT/

The magnitude operators \$L (less than or equal to) and \$G (Greater than or equal to) can be combined to give a range of specific temperatures, velocities, etc. For example:

\$A...\$G/1000/MPH\$L/2000/MPH/

Thus, the computer will select all documents that deal with speeds between these limits and contain the other specific descriptor combinations requested.

The NUMERICAL operator is an expanded EQUAL operator that permits a search for a phrase of two or more descriptors with fewer operators. For example, to search for "Underwater Detection Systems," it is merely necessary to enter the words in sequence behind the NUMERICAL operator as,

\$3/UNDERWATER/DETECTION/SYSTEM/,

which is simpler than the use of the EQUAL operator which requires

\$A\$E/UNDERWATER/DETECTION\$E/DETECTION/  
SYSTEM/.

With the NUMERICAL operator it is possible to combine as many words as desired, lessening the chance for error in writing the search.

The SELECTIVE NUMERICAL operator has two functions in the retrieval program. First, it allows the selection of a broad phrase from a specific phrase, and second, it permits the retrieval of an inverted phrase. Thus, if the broad phrase "Underwater Detection Systems" is requested, the librarian uses the SELECTIVE NUMERICAL operator:

\$3, 4/UNDERWATER/DETECTION/SYSTEM/.

The computer will then search for /SYSTEM/ and if /UNDERWATER/ /DETECTION/ are in sequence within three words in front of /SYSTEM/, it will accept the phrase. Thus, if /UNDERWATER/ /DETECTION/ SYSTEM/, /UNDERWATER/SHIP/DETECTION/SYSTEM/, or /UNDERWATER/TORPEDO/DETECTION/SYSTEM/ are listed in this sequence as descriptors for documents, these documents will be accepted and printed out.

Inverted phrases may also be searched by using the SELECTIVE NUMERICAL two or more times with a different descriptor in front of the last word of the phrase each time. A phrase can often be stated in two or more ways, such as "Laminar Compressible Viscous Flow,"

which also may be stated as "Compressible Laminar Viscous Flow," "Viscous Laminar Compressible Flow," "Compressible Viscous Laminar Flow," "Viscous Compressible Laminar Flow," and "Laminar Viscous Compressible Flow." The cataloger merely enters the phrase in the form the author writes it, and it is retrieved in the following manner:

```
$$$2,4/VISCOUS/FLOW$2,4/COMPRESSIBLE/FLOW$2,4/
LAMINAR/FLOW
```

The computer will accept any phrase in which /FLOW/ is the last word and /VISCOUS/ is in front of it within three words. /COMPRESSIBLE/ and /LAMINAR/ are selected in the same manner.

The IBM 7094 computer can process 1,000 or more questions at one time. The searches can be very complex, with many OR operators in a single search. As a result, time can be saved in the cataloging of documents. For example, a work tape of approximately 4,000 records can be searched for 600 separate descriptors in about four minutes. The time required for looking up each descriptor or code in file cataloging is not comparable to the time and expense of the computer.

C-8  
Search Program

1

BCC-359

6 OCT 1965

TO- DISTRIBUTION  
FROM- J. E. PEBBLES  
SUBJECT- 7094 SEARCH PROGRAM - 7094 SORT PROGRAM

TABLE OF CONTENTS

THE SEARCH PROGRAM

INTRODUCTION.....	1
INPUT.....	1
OUTPUT.....	1
DESCRIPTORS.....	2
CONCATENATION.....	2
DELETION OF SEARCH REQUEST FROM OUTPUT.....	4
THE SEARCH REQUEST.....	4
COLLATING SEQUENCE.....	5
THE OPERATOR \$L.....	6
THE OPERATOR \$E.....	6
THE OPERATOR \$G.....	6
THE OPERATOR \$I,J.....	7
THE LOGICAL OPERATORS.....	7
EXAMPLES.....	8
THE OPTION CARD.....	9
FORMAT CARDS.....	10
TAPE AND LABEL CARDS.....	10
ERROR MESSAGES.....	11

THE SORT PROGRAM

INTRODUCTION.....	12
THE SORT KEY.....	12
THE SORT CODE.....	12
THE SORT DATA CARD.....	12
USAGE OF THE SYSTEM.....	13
TABLE 1 - CHARACTER REPRESENTATION.....	16

\*\*\*\*\*  
 INTRODUCTION  
 \*\*\*\*\*

THE SEARCH PROGRAM IS DESIGNED TO EXAMINE ONE OR MORE MAGNETIC TAPE FILES IN STANDARD INFORMATION PROCESSING SYSTEM (SIPS) FORMAT AND RECORD ON A NEW FILE THOSE RECORDS WHICH SATISFY AT LEAST ONE SEARCH REQUEST.

A STANDARD SIPS FORMATTED FILE CONSISTS OF RECORDS UP TO 80,000 CHARACTERS LONG, THE LAST RECORD BEING FOLLOWED BY A FILE MARK. EACH RECORD CONSISTS OF A 5-DIGIT RECORD NUMBER, FOLLOWED BY TWO FORMAT CONTROL CHARACTERS (FOR USE BY THE 'PRINT' PROGRAM, SEE BCC-352), FOLLOWED BY THE TEXT OF THE RECORD, FOLLOWED BY A TERMINAL DOLLAR SIGN. THIS IS, FOR EXAMPLE, THE FORMAT PROVIDED BY THE 'EDIT' PROGRAM (SEE BCC-345).

THE SEARCH IS MADE BY LOOKING FOR LOGICAL OR POSITIONAL COMBINATIONS OF DESCRIPTORS (AS SPECIFIED BY THE SEARCH REQUEST) IN EACH RECORD OF THE INPUT FILE.

\*\*\*\*\*  
 INPUT  
 \*\*\*\*\*

THE SEARCH PROGRAM ACCEPTS AS INPUTS ONE OR MORE TAPE FILES IN STANDARD SIPS FORMAT AND A DECK OF CARDS CONTAINING PROGRAM PARAMETERS AND ONE OR MORE REQUESTS.

\*\*\*\*\*  
 OUTPUT  
 \*\*\*\*\*

THE OUTPUT IS WRITTEN TO A NEW FILE IN STANDARD FORMAT CONTAINING, FOR EACH REQUEST FOLLOWED IMMEDIATELY BY THOSE RECORDS WHICH SATISFY THAT REQUEST. A LISTING OF THE SEARCH REQUESTS IS ALSO PROVIDED PLUS A SUMMARY TABLE INDICATING, FOR EACH REQUEST, THE MAXIMUM NUMBER OF RECORDS TO BE PRINTED (AS SPECIFIED BY THE SEARCH REQUEST) AS WELL AS THE ACTUAL NUMBER OF HITS OBTAINED.

EACH REQUEST NORMALLY CAUSES FOUR RECORDS TO BE WRITTEN ON THE OUTPUT TAPE. THESE RECORDS ARE 1) A FORMAT RECORD, 2) A NEW PAGE NUMBER RECORD, 3) THE SEARCH REQUEST RECORD, 4) A PAGE EJECT RECORD. RECORDS 1, 2, AND 4 ARE USED AS CONTROL RECORDS BY THE 'PRINT' PROGRAM (BCC-352) IN LISTING THE OUTPUT.

THE 7094 SEARCH PROGRAM.  
OUTPUT

FOR EXAMPLE, AN OUTPUT TAPE MAY APPEAR AS FOLLOWS-

...  
00000F 'FORMAT PARAMETERS'  
00000N 001  
0000099'SEARCH REQUEST'  
00000\*  
(ALL RECORDS SATISFYING ABOVE REQUEST)  
...

\*\*\*\*\*  
DESCRIPTORS  
\*\*\*\*\*

BY A DESCRIPTOR WE MEAN A STRING OF CHARACTERS BOUNDED BY VIRGULES (/). THE CHARACTERS IN THIS STRING MAY BE ANY LEGITIMATE CHARACTERS EXCEPT THE VIRGULE ITSELF AND THE DOLLAR SIGN, WHICH IS RESERVED FOR USE OF THE SYSTEM. SPACES MAY BE USED, AND ARE TREATED LIKE ANY OTHER CHARACTER. THUS TWO DESCRIPTORS ARE THE SAME ONLY IF THEY ARE IDENTICAL CHARACTER BY CHARACTER, SPACES INCLUDED. A LIST OF THE AVAILABLE PRINTING CHARACTERS IS GIVEN IN TABLE 1.

A DESCRIPTOR MUST CONTAIN AT LEAST ONE CHARACTER (NOT COUNTING THE VIRGULES THAT BOUND IT) AND MAY CONTAIN AS MANY AS THE LENGTH OF THE RECORD PERMITS.

HOWEVER, IF SUCCESSIVE VIRGULES OCCUR, EACH ONE EXCEPT THE FIRST OF THE STRING IS TREATED AS DEFINING A ZERO-CHARACTERED DESCRIPTOR.

THE USUAL RECORD CONTAINS SOME FREE TEXT AS WELL AS SOME DESCRIPTORS. IT IS ADVISABLE TO PUT ALL THE DESCRIPTORS IN ONE CONSECUTIVE STRING (ONLY ONE VIRGULE BEING REQUIRED BETWEEN SUCCESSIVE DESCRIPTORS) AND PUT THE FREE TEXT EITHER AHEAD OF THIS STRING OR BEHIND IT, OR BOTH. IF FREE TEXT IS PUT BETWEEN TWO DESCRIPTORS THEN IT WILL BE BOUNDED BY THE VIRGULES OF THOSE DESCRIPTORS AND HENCE WILL ITSELF BE TAKEN AS A DESCRIPTOR. USUALLY THIS DOES NO HARM (EXCEPT BY SLOWING DOWN THE SEARCH A BIT) SINCE SUCH A STRING WILL NOT OFTEN COINCIDE EXACTLY WITH ONE OF THE REAL DESCRIPTORS IN THE SEARCH REQUEST.

\*\*\*\*\*  
CONCATENATION OF RECORDS  
\*\*\*\*\*

ASSUME THAT THERE IS A FIXED FIELD AT LEAST 3 CHARACTERS IN LENGTH BEGINNING IN COLUMN 8 OF EVERY RECORD OF THE FILE. IT IS POSSIBLE TO CAUSE ALL OF THE INFORMATION BETWEEN THIS FIXED FIELD AND THE END OF THE RECORD TO BE CONCATENATED WITH THIS SAME PORTION OF ALL OR SOME OF THE SUCCEEDING RECORDS BEFORE SEARCHING.

AN S IN THE RIGHTMOST COLUMN OF THE FIXED FIELD CAUSES CONCATENATION AT THE BEGINNING OF SUCCEEDING RECORDS. A T CAUSES CONCATENATION AT THE END OF THE RECORDS. THE S AND T WILL BE REFERRED



AS LEVEL INDICATORS. THE 2 CHARACTERS IMMEDIATELY PRECEDING LEVEL INDICATOR MUST CONTAIN AN INTEGER WHICH WILL BE REFERRED AS A LEVEL NUMBER. SINCE THERE ARE 99 POSSIBLE LEVELS OF CATENATION, IT IS POSSIBLE TO CONCATENATE UP TO 99 RECORDS AT BEGINNING AND UP TO 99 RECORDS AT THE END OF SUCCEEDING RE-DS.

THE SMALLER LEVEL NUMBERS PRECEDING AN S LEVEL INDICATOR SE THAT RECORD TO OCCUR FURTHER TO THE LEFT IN THE CONCATENATED STRING. THE SMALLER LEVEL NUMBERS PRECEDING A T LEVEL INDICATOR SE THAT RECORD TO OCCUR FURTHER TO THE RIGHT IN THE CONCATENATED STRING. ALSO, A LEVEL NUMBER CAUSES THE REPLACEMENT OF ALL PRECEDING RECORDS WITH THE SAME LEVEL INDICATOR WHICH HAD AN EQUAL HIGHER LEVEL NUMBER. IN PARTICULAR, A LEVEL NUMBER OF 0 WILL REPLACE ALL PRECEDING RECORDS WITH THE SAME LEVEL INDICATOR.

IT IS POSSIBLE TO SEARCH ALL RECORDS WITHOUT CONCATENATION, S THIS FEATURE IS COMPLETELY OPTIONAL. IN THIS CASE THE FIXED LD, IF PRESENT, WILL BE INCLUDED AS PART OF THE TEXT. THUS, IT NOT NECESSARY TO HAVE THE FIXED FIELD UNLESS CONCATENATION IS IRED.

HOWEVER, THERE ARE 3 OPTIONS AVAILABLE WHEN SEARCHING WITH CATENATION. THESE ARE -

- 1) SEARCH ONLY RECORDS WHICH HAVE NO LEVEL INDICATORS.
- 2) SEARCH ONLY RECORDS WHICH HAVE NO LEVEL INDICATORS OR HAVE LEVEL INDICATORS.
- 3) SEARCH ALL RECORDS.

CONSIDER THE FOLLOWING FILE WHICH HAS A FIXED FIELD 4 CHARAC-S LONG. NOTE THAT THE FIXED FIELD IN RECORDS WITH LEVEL INDICATORS IS UNIQUE AND THUS FORMS A HANDY SORT KEY FOR THESE RE-DS.

```
01 A01SBUMBLEBEE COMPUTING CENTERS$
02 A01T/BCC/GROUP/$
03     BCC$
04 B03SBUMBLEBEE COMPUTING PROGRAMMING$
05 B03T/BCC-1/PROJECT/$
06     BCC-1$
07 C03S LOGICAL PROGRAMMING$
08 C03T/BCC-3/PROJECT/$
09     BCC-3$
```

THE FOLLOWING WOULD BE THE APPEARANCE OF THE FILE AFTER CATENATION (I.E., AT SEARCH TIME).

```
01 A01SBUMBLEBEE COMPUTING CENTERS$
02 A01TBUMBLEBEE COMPUTING CENTER/BCC/GROUP/$
03     BUMBLEBEE COMPUTING CENTER BCC/BCC/GROUP/$
04 B03SBUMBLEBEE COMPUTING CENTER MATHEMATICAL PROGRAMMING/
/GROUP/$
05 B03TBUMBLEBEE COMPUTING CENTER MATHEMATICAL PROGRAMMING/
-1/PROJECT//BCC/GROUP/$
06     BUMBLEBEE COMPUTING CENTER MATHEMATICAL PROGRAMMING
-1/BCC-1/PROJECT//BCC/GROUP/$
```

THE 7094 SEARCH PROGRAM.  
CONCATENATION OF RECORDS

00007 C03SBUMBLEBEE COMPUTING CENTER LOGICAL PROGRAMMING/BCC-1/  
PROJECT//BCC/GROUP/\$  
00008 C03TBUMBLEBEE COMPUTING CENTER LOGICAL PROGRAMMING/BCC-3/  
PROJECT//BCC/GROUP/\$  
00009 BUMBLEBEE COMPUTING CENTER LOGICAL PROGRAMMING BCC-3/  
BCC-3/PROJECT//BCC/GROUP/\$

ALL OF THESE RECORDS WOULD BE SEARCHED UNDER OPTION 3,  
WHEREAS ONLY RECORDS 00002, 00003, 00005, 00006, 00008, 00009  
WOULD BE SEARCHED UNDER OPTION 2 AND RECORDS 00003, 00006, 00009  
WOULD BE SEARCHED UNDER OPTION 1.

NOTE THAT THE IDENTIFICATION OF EACH RECORD SEARCHED IS THAT  
OF THE LAST RECORD INCLUDED DURING CONCATENATION.

THIS FEATURE IS IMPLEMENTED BY PLACING THE OPTION NUMBER 1,  
2, OR 3 AND THE FIXED FIELD LENGTH IN THE APPROPRIATE FIELDS ON  
THE 'OPTION' CARD AS DESCRIBED LATER.

\*\*\*\*\*  
DELETION OF SEARCH REQUEST FROM OUTPUT  
\*\*\*\*\*

THE 7094 SEARCH PROGRAM IS PRESET TO INCLUDE THE SEARCH  
REQUEST ON THE HIT OUTPUT TAPE IMMEDIATELY PRECEDING THE RECORDS  
WHICH SATISFY THAT REQUEST. HOWEVER, A 1 IN THE APPROPRIATE FIELD  
OF THE 'OPTION' CARD WILL CAUSE THE FOUR RECORDS ASSOCIATED WITH  
EACH REQUEST (SEE OUTPUT SECTION) TO BE OMITTED FROM THE OUTPUT  
TAPE.

THIS FEATURE IS USEFUL FOR REARRANGING A FILE IN A SPECIFIED  
ORDER.

\*\*\*\*\*  
THE SEARCH REQUEST  
\*\*\*\*\*

EACH SEARCH REQUEST IS PUNCHED ON ONE OR MORE CARDS ACCORDING  
TO THE FOLLOWING RULE. THE FIRST CARD MUST NOT HAVE A BLANK IN  
COLUMN 1, AND ALL FOLLOWING CARDS OF THE SAME REQUEST MUST HAVE A  
BLANK IN COLUMN 1. IF THE LAST NON-SPACE CHARACTER ON A CARD IS A  
VIRGULE THEN ALL TRAILING BLANKS ARE DELETED. IF THE LAST NON-  
SPACE CHARACTER IS NOT A VIRGULE THEN ALL BUT ONE OF THE TRAILING  
BLANKS ARE DELETED. THEREFORE, IT IS NECESSARY TO END EACH CARD  
EITHER WITH A) A FULL WORD OF FREE TEXT OR B) A VIRGULE OF THE  
SEARCH DESCRIPTION FOLLOWING AN OPERATOR OR DESCRIPTOR. ALL  
LEADING BLANKS ON THE CARD ARE DELETED.

EACH REQUEST SHOULD START WITH AN IDENTIFYING NAME OF SIX  
CHARACTERS OR LESS, FOLLOWED BY A MAXIMUM OUTPUT COUNT AND THEN  
THE SEARCH DESCRIPTION, THE FIELDS BEING SEPARATED BY COMMAS. THE  
SEARCH DESCRIPTION MAY CONTAIN FREE TEXT IDENTIFYING THE SEARCH.  
FREE TEXT MAY PRECEDE AND/OR FOLLOW THE SEARCH DESCRIPTION.

IF THE MAXIMUM OUTPUT COUNT IS LESS THAN THE ACTUAL NUMBER OF  
HITS, ONLY THE NUMBER SPECIFIED BY THE MAXIMUM OUTPUT COUNT WILL  
APPEAR ON THE HIT OUTPUT TAPE. HOWEVER, THE SUMMARY TABLE WILL

THE 7094 SEARCH PROGRAM.  
THE SEARCH REQUEST

INDICATE THE ACTUAL NUMBER OF HITS. SPECIFICALLY, IF THE MAXIMUM OUTPUT COUNT IS 0, NO OUTPUT WILL APPEAR ON THE HIT TAPE FOR THAT REQUEST, BUT THE NUMBER OF HITS WILL BE RECORDED IN THE SUMMARY TABLE.

FOR EXAMPLE, THE FOLLOWING IS A LEGAL SEARCH REQUEST.

SRCH1,10, OBTAIN A MAXIMUM OF 10 ITEMS ABOUT COMPUTERS WHICH WERE PUBLISHED IN 1963 \$A/COMPUTERS\$E/1963/DATE/

THE FOLLOWING DISCUSSION WILL VERIFY THAT THIS REQUEST IS GRAMMATICALLY CORRECT.

THE SEARCH DESCRIPTION CONSISTS OF DESCRIPTORS, VIRGULES, AND THE OPERATORS

- \$A LOGICAL AND
- \$O LOGICAL OR (AND/OR)
- \$N LOGICAL NOT
- \$L LESS THAN OR EQUAL TO
- \$E EQUAL TO
- \$G GREATER THAN OR EQUAL TO.
- \$I, J NUMERICAL

THE SYNTAX AND SEMANTICS OF THE SEARCH DESCRIPTION ARE GIVEN IN DETAIL IN THE FOLLOWING PARAGRAPHS. THE SYNTAX IS BASED ON THE POLISH PREFIX NOTATION OF LUKASZEWICZ, IN WHICH BINARY OPERATORS ARE PUT AHEAD OF THE TWO OPERANDS INSTEAD OF BETWEEN THEM. THIS NOTATION AVOIDS THE NEED FOR GROUPING PARENTHESES AND SIMPLIFIES THE COMPUTER PROGRAM. AFTER THE INITIAL STRANGENESS HAS WORN OFF, YOU WILL FIND IT ECONOMICAL AND CONVENIENT.

NOTICE THAT EACH DESCRIPTOR IN THE SEARCH DESCRIPTION IS BOUNDED BY VIRGULES, AS IN THE STANDARD TAPE FORMAT, EXCEPT THAT A VIRGULE IMMEDIATELY PRECEDING A DOLLAR SIGN IS OMITTED.

\*\*\*\*\*  
COLLATING SEQUENCE  
\*\*\*\*\*

THE OPERATORS \$L AND \$G, AS DESCRIBED BELOW, REQUIRE THAT A DESCRIPTOR IN THE RECORD BE COMPARED FOR MAGNITUDE WITH A DESCRIPTOR IN THE SEARCH DESCRIPTION (IF THEY ARE NOT EQUAL).

THESE TWO DESCRIPTORS MAY BE OF UNEQUAL LENGTH, IN WHICH CASE THE SHORTER ONE WILL BE DEEMED THE LESSER. WHEN THE DESCRIPTORS ARE OF THE SAME LENGTH, THE COMPARISON IS MADE ACCORDING TO THE COLLATING SEQUENCE AS GIVEN IN DETAIL IN TABLE 1 AND IN GENERAL BELOW.

THE BLANK IS SMALLEST, FOLLOWED IN ORDER BY

- . ) + \* - , ( =
- ALPHABET IN USUAL ORDER
- DIGITS IN USUAL ORDER.

AS STATED EARLIER, TWO DESCRIPTORS ARE EQUAL WHEN THEY ARE IDENTICAL CHARACTER BY CHARACTER.

THE 7094 SEARCH PROGRAM.  
THE LESS THAN OPERATOR, \$L

\*\*\*\*\*  
THE LESS THAN OPERATOR, \$L  
\*\*\*\*\*

IF X, Y, AND Z ARE ANY DESCRIPTORS THEN \$L/X/Y/ IS A LEGITIMATE TERM IN A SEARCH DESCRIPTION. THIS TERM WILL SELECT A RECORD FROM THE INPUT FILE IF AND ONLY IF THAT RECORD CONTAINS THE TWO CONSECUTIVE DESCRIPTORS /Z/Y/ IN THAT ORDER AND

- A1) THE DESCRIPTORS X AND Z HAVE THE SAME NUMBER OF CHARACTERS, AND
- A2) Z EITHER IS THE SAME AS X OR PRECEDES IT IN THE COLLATING SEQUENCE (I.E. IS LESS THAN OR EQUAL TO X), OR

B) Z IS SHORTER (CONTAINS LESS CHARACTERS) THAN X.

ADDITIONALLY, THE TERM \$L/X\$I,J/X1/X2/.../X1/ WILL SELECT A RECORD IF

- A) THE TERM \$I,J/X1/X2/.../X1/ (SEE BELOW) IS SATISFIED AND
- B) THE DESCRIPTOR Z IMMEDIATELY PRECEDING X1 IN THE RECORD SATISFIES THE CONDITIONS A1, A2, AND B ABOVE.

\*\*\*\*\*  
THE EQUALS OPERATOR, \$E  
\*\*\*\*\*

IF X AND Y ARE ANY DESCRIPTORS, THEN \$E/X/Y/ IS A LEGITIMATE TERM IN A SEARCH DESCRIPTION. IT WILL SELECT A RECORD FROM THE INPUT FILE IF AND ONLY IF THAT RECORD CONTAINS THE TWO CONSECUTIVE DESCRIPTORS /X/Y/ IN THAT ORDER.

THE TERM \$E/X\$I,J/X1/X2/.../X1/ WILL SELECT A RECORD IF

- A) THE TERM \$I,J/X1/X2/.../X1/ (SEE BELOW) IS SATISFIED AND
- B) THE DESCRIPTOR Z IMMEDIATELY PRECEDING X1 IN THE RECORD IS THE SAME AS X.

\*\*\*\*\*  
THE GREATER THAN OPERATOR, \$G  
\*\*\*\*\*

IF X, Y, AND Z ARE ANY DESCRIPTORS THEN \$G/X/Y/ IS A LEGITIMATE TERM IN A SEARCH DESCRIPTION. THIS TERM WILL SELECT A RECORD FROM THE INPUT FILE IF AND ONLY IF THAT RECORD CONTAINS THE TWO CONSECUTIVE DESCRIPTORS /Z/Y/ IN THAT ORDER, AND

- A1) THE DESCRIPTORS X AND Z HAVE THE SAME NUMBER OF CHARACTERS, AND

A2) Z EITHER IS EQUAL TO X OR FOLLOWS IT IN THE COLLATING SEQUENCE (I.E. IS GREATER THAN OR EQUAL TO X), OR

B) Z IS LONGER (CONTAINS MORE CHARACTERS) THAN X.

ADDITIONALLY, THE TERM \$G/X\$I,J/X1/X2/.../X1/ WILL SELECT A RECORD IF

- A) THE TERM \$I,J/X1/X2/.../X1/ (SEE BELOW) IS SATISFIED AND
- B) THE DESCRIPTOR Z IMMEDIATELY PRECEDING X1 IN THE RECORD SATISFIES THE CONDITIONS A1, A2, AND B ABOVE.

THE NUMERICAL OPERATOR, \$I,J

\*\*\*\*\*  
 THE NUMERICAL OPERATOR, \$I,J  
 \*\*\*\*\*

LET I AND J BE ANY POSITIVE INTEGERS. IF  $X_1, X_2, \dots, X_I$  ARE ANY DESCRIPTORS AND J IS GREATER THAN OR EQUAL TO I, THEN  $\$I, J/X_1/X_2/\dots/X_I/$  IS A LEGITIMATE TERM IN A SEARCH DESCRIPTION. IT WILL SELECT A RECORD FROM THE INPUT FILE IF AND ONLY IF

A) THE RECORD CONTAINS THE I DESCRIPTORS  $X_1$  THROUGH  $X_I$  IN THE ORDER SPECIFIED, AND

B) THE DESCRIPTOR  $X_1$  OCCURS WITHIN J DESCRIPTORS OF  $X_I$ , I.E., THERE ARE NO MORE THAN J-2 DESCRIPTORS BETWEEN  $X_1$  AND  $X_I$ .

IN PARTICULAR,  $\$I/X_1/\dots/X_I/$  IS A LEGITIMATE TERM IN A SEARCH DESCRIPTION AND WILL BE CONVERTED BY THE PROGRAM TO  $\$I, I/X_1/\dots/X_I/$ .

IT IS NOTED, IN PASSING, THAT THE TERM  $\$2/X/Y/$  IS EQUIVALENT TO  $\$E/X/Y/$  ALREADY DISCUSSED.

\*\*\*\*\*  
 THE LOGICAL OPERATORS  
 \*\*\*\*\*

THE LOGICAL OPERATORS \$A (FOR AND), \$O (FOR OR), AND \$N (FOR NOT) MAY NOW BE DEFINED RECURSIVELY.

IF X AND Y ARE DESCRIPTORS THEN

A)  $/X/$  IS A SEARCH DESCRIPTION.

B)  $\$L/X/Y/$  IS A SEARCH DESCRIPTION.

C)  $\$E/X/Y/$  IS A SEARCH DESCRIPTION.

D)  $\$G/X/Y/$  IS A SEARCH DESCRIPTION.

E)  $\$I, J/X_1/X_2/\dots/X_I/$  IS A SEARCH DESCRIPTION

THE SEARCH DESCRIPTION  $/X/$  SELECTS A RECORD FROM THE INPUT FILE IF AND ONLY IF THAT RECORD CONTAINS THE DESCRIPTOR X. THE RULES BY WHICH THE DESCRIPTIONS CONTAINING \$L, \$E, \$G, AND \$I, J SELECT RECORDS HAVE BEEN GIVEN IN THE PRECEDING PARAGRAPHS. NOTICE THAT A LEGITIMATE SEARCH DESCRIPTION ALWAYS ENDS WITH A VIRGULE, AND MAY BEGIN WITH EITHER A VIRGULE OR A DOLLAR SIGN.

SUPPOSE S/, T/ ARE ANY SEARCH DESCRIPTIONS, SO THAT S IS A STRING OF SYMBOLS BEGINNING WITH EITHER A VIRGULE OR A DOLLAR SIGN, AND SO IS T. THEN

F)  $\$NS/$  IS A SEARCH DESCRIPTION WHICH SELECTS THOSE RECORDS WHICH S/ DOES NOT SELECT.

G)  $\$AST/$  IS A SEARCH DESCRIPTION WHICH SELECTS THOSE RECORDS SELECTED BY BOTH S/ AND T/.

H)  $\$OST/$  IS A SEARCH DESCRIPTION WHICH SELECTS THOSE RECORDS SELECTED BY EITHER S/ OR T/ OR BOTH.

THE 7094 SEARCH PROGRAM.  
EXAMPLES

\*\*\*\*\*  
EXAMPLES  
\*\*\*\*\*

IN THIS SET OF EXAMPLES WE ASSUME THAT THE INPUT REFERS TO THE TECHNICAL PAPERS ON SOME SUBJECT, SAY INFORMATION RETRIEVAL. EACH RECORD IN THE FILE PERTAINS TO ONE TECHNICAL PAPER AND CONTAINS THE USUAL BIBLIOGRAPHIC INFORMATION FOR THAT PAPER, AS WELL AS A STRING OF DESCRIPTORS. WE ASSUME THAT THE YEAR OF PUBLICATION OF THE PAPER (FOUR DECIMAL DIGITS) IS ALWAYS ONE OF THE DESCRIPTORS, AND IS IMMEDIATELY FOLLOWED BY THE DESCRIPTOR /DATE/.

THUS, FOR EXAMPLE, A PAPER PUBLISHED IN 1960 WOULD CONTAIN THE STRING .../1960/DATE/... SOMEWHERE AMONG THE SEQUENCE OF DESCRIPTORS.

THEN THE SEARCH DESCRIPTION

\$E/1960/DATE/

SELECTS ALL PAPERS PUBLISHED IN 1960.

\$N\$E/1960/DATE/

SELECTS ALL PAPERS NOT PUBLISHED IN 1960 (AS WELL AS ANY FOR WHICH THE DATE DESCRIPTOR-PAIR WAS OMITTED).

\$L/1960/DATE/

SELECTS ALL THE PAPERS PUBLISHED IN 1960 OR EARLIER.

\$L/1000\$2,3/COST/MATERIAL/

WOULD SELECT, AMONG OTHERS, A RECORD CONTAINING THE STRING OF DESCRIPTORS .../900/COST/OF/MATERIAL/... AS WELL AS A RECORD CONTAINING THE DESCRIPTORS .../900/COST/MATERIAL/...

\$G/1956/DATE/

SELECTS ALL THE PAPERS PUBLISHED IN 1956 OR LATER.

\$A\$G/1956/DATE\$L/1960/DATE/

SELECTS ALL THOSE PUBLISHED FROM 1956 TO 1960, INCLUSIVE.

\$N\$A\$G/1956/DATE\$L/1960/DATE/

SELECTS THOSE WHICH WERE NOT PUBLISHED BETWEEN 1956 AND 1960, INCLUSIVE.

\$O/JONES,AK\$A\$G/1956/DATE\$L/1960/DATE/

SELECTS THOSE PAPERS WHICH EITHER ARE BY A.K. JONES OR APPEARED

BETWEEN 1956 AND 1960.

\$3,4/BIG/BLACK/COW/

WOULD SELECT, FOR EXAMPLE, A RECORD CONTAINING THE STRING OF  
CHARACTERS .../BIG/FAT/BLACK/COW/... BUT NOT THE STRING .../BIG/  
/OLD/BLACK/COW/...

\*\*\*\*\*  
THE OPTION CARD  
\*\*\*\*\*

THE 'OPTION' CARD IS USED TO SUPPLY NECESSARY INFORMATION AS  
WELL AS OPTIONAL INFORMATION TO THE SEARCH PROGRAM. IT MUST BE  
INCLUDED AND SHOULD BE THE FIRST CARD OF THE SEARCH REQUEST DECK.  
THE 'OPTION' CARD MUST BE PUNCHED AS FOLLOWS -

COLS. 1-6 - THE WORD 'OPTION'  
COLS. 8- - 'MRS,TM,CCO,FFL,OPF,IT1,OT,ST,ST,ST,ST,IT2'

RE

- MRS = MAXIMUM RECORD SIZE OF INPUT FILE IN CHARACTERS.
- TM = A CODE SPECIFYING TAPE MODE.
  - 0 = UNBLOCKED TAPE
  - 1 = BLOCKED TAPE
- CCO = A CODE SPECIFYING THE CONCATENATION OPTION.
  - 0 = DO NOT CONCATENATE, SEARCH ALL RECORDS
  - 1 = CONCATENATE, SEARCH ONLY RECORDS WITHOUT LEVEL INDICATORS
  - 2 = CONCATENATE, SEARCH ONLY RECORDS WITHOUT LEVEL INDICATORS OR T INDICATORS
  - 3 = CONCATENATE, SEARCH ALL RECORDS
- FFL = THE FIXED FIELD LENGTH REQUIRED FOR CONCATENATION. THIS FIELD MUST BE INCLUDED BUT IS IGNORED IF 'CCO' IS 0.
- OPF = A CODE SPECIFYING AN OUTPUT OPTION.
  - 0 = INCLUDE FOUR RECORDS ASSOCIATED WITH SEARCH REQUEST ON OUTPUT TAPE
  - 1 = DO NOT INCLUDE THE FOUR RECORDS ON OUTPUT TAPE
- IT1 = SYMBOLIC TAPE NAME 'SYSXZN' FOR INPUT TAPE.
- OT = SYMBOLIC TAPE NAME 'SYSXZN' FOR OUTPUT TAPE.
- ST = SYMBOLIC TAPE NAME 'SYSXZN' FOR SCRATCH TAPE. THERE MUST BE 4 SCRATCH TAPES.
- IT2 = SYMBOLIC TAPE NAME 'SYSXZN' OF ALTERNATE INPUT UNIT IF THERE IS MORE THAN ONE INPUT FILE. OTHERWISE, THIS FIELD IS OMITTED.

BEGINNING IN COLUMN 8 AS INDICATED, ALL FIELDS ARE PUNCHED CONTINUOUSLY SEPARATED BY COMMAS WITH NO INTERVENING BLANKS.

\*\*\*\*\*  
FORMAT CARDS  
\*\*\*\*\*

SINCE THE OUTPUT TAPE MAY BE LISTED WITH THE 'PRINT' PROGRAM (SEE BCC-352), IT IS DESIRABLE THAT THE USER SPECIFY THE FORMAT FOR THIS LISTING THROUGH THE SEARCH PROGRAM. THIS SHOULD BE DONE BY PUNCHING A CARD WITH THE WORD 'FORMAT' IN COLS 1-6 AND FOLLOWING THIS CARD WITH A STANDARD PRINT PARAMETER CARD (SEE BCC-352). THESE CARDS SHOULD BE INSERTED IN FRONT OF THE REQUEST TO WHICH THEY APPLY. THE SPECIFIED FORMAT WILL APPLY TO THE OUTPUT OF ALL REQUESTS UNTIL ANOTHER FORMAT CARD APPEARS. THUS IT IS POSSIBLE TO HAVE THE OUTPUT FROM EACH REQUEST LISTED WITH A DIFFERENT FORMAT. IF NO FORMAT CARD IS SPECIFIED, A 'STANDARD' LISTING WILL BE GIVEN.

\*\*\*\*\*  
TAPE AND LABEL CARDS  
\*\*\*\*\*

IF THERE IS MORE THAN ONE INPUT TAPE, A TAPE CARD MUST BE INCLUDED FOR EACH TAPE. THESE CARDS ARE PLACED AT THE BEGINNING OF THE SEARCH REQUEST DECK (AFTER THE OPTION CARD) IN THE ORDER THAT THE TAPES ARE TO BE SEARCHED.

THESE CARDS SHOULD BE PUNCHED AS FOLLOWS

COLS.1-4 THE WORD 'TAPE'

COLS.5-72 THE FOLLOWING TWO FIELDS IN THAT ORDER

1. EXTERNAL TAPE NUMBER OR NAME
2. INTERNAL TAPE LABEL

THE TAPE LABEL SHOULD BE IMMEDIATELY PRECEDED AND FOLLOWED BY A \$. THE CHARACTERS BOUNDED BY THESE \$ SIGNS WILL BE COMPARED WITH A CORRESPONDING NUMBER OF CHARACTERS BEGINNING WITH POSITION 8 OF THE FIRST TAPE RECORD. IF THEY ARE NOT EQUAL, THIS TAPE WILL NOT BE SEARCHED. AN APPROPRIATE MESSAGE WILL BE PRINTED OFF-LINE AND THE JOB WILL CONTINUE TO PROCESS THE REMAINING TAPES.

THE INCLUSION OF A TAPE LABEL ON ANY TAPE CARD IS OPTIONAL. FOR A SINGLE TAPE SEARCH, THE TAPE CARD IS OPTIONAL.

SUPPOSE, FOR EXAMPLE, THAT A SEARCH IS TO BE RUN ON TAPES 100, 101, AND 102. ALSO SUPPOSE THAT TAPE 100 HAS THE LABEL 'SEARCH TAPE 1', TAPE 101 HAS NO LABEL, AND TAPE 102 HAS THE LABEL 'SEARCH TAPE 2'. THEN THE FOLLOWING TAPE CARDS SHOULD BE INCLUDED IN THE SEARCH REQUEST DECK. (PUNCHING BEGINS IN COLUMN 1)

TAPE 100 \$SEARCH TAPE 1\$  
TAPE 101  
TAPE 102 \$SEARCH TAPE 2\$



\*\*\*\*\*  
ERROR MESSAGES  
\*\*\*\*\*

THE FOLLOWING MESSAGES MAY OCCUR IN THE RIGHT MARGIN OF THE OFF--LINE LISTING OPPOSITE THE SEARCH REQUEST TO WHICH THEY APPLY DURING A SEARCH RUN -

PRINTOUT	MEANING	ACTION
ERROR 1	TOO FEW OPERATORS FOR THE DESCRIPTORS AT SOME POINT IN THE QUESTION	THIS SEARCH IS BYPASSED, NOTHING ON OUTPUT TAPE. REWRITE THE QUESTION.
ERROR 2	TOO FEW DESCRIPTORS FOR THE OPERATORS IN THE ENTIRE QUESTION	THIS SEARCH IS BYPASSED, NOTHING ON OUTPUT TAPE. REWRITE THE QUESTION.
ERROR 3	AN OPERATOR HAS OCCURRED IN AN ILLEGAL POSITION	THIS SEARCH IS BYPASSED, NOTHING ON OUTPUT TAPE. REWRITE THE QUESTION.
ERROR 4	SEARCH REQUEST DOES NOT END WITH A /	THIS SEARCH IS BYPASSED, NOTHING ON OUTPUT TAPE. REWRITE THE QUESTION.
ERROR 5	ILLEGAL OPERATOR	THIS SEARCH IS BYPASSED, NOTHING ON OUTPUT TAPE. REWRITE THE QUESTION.
ERROR 6	FIRST TERM AFTER \$L, \$E, OR \$G IS NOT A SIMPLE TERM	THIS SEARCH IS BYPASSED, NOTHING ON OUTPUT TAPE. REWRITE THE QUESTION.
ERROR 7	NUMERICAL OPERATOR NOT FOLLOWED BY PROPER NO. OF SIMPLE DESCRIPTORS	THIS SEARCH IS BYPASSED, NOTHING ON OUTPUT TAPE. REWRITE THE QUESTION.
ERROR 8	ILLEGAL OPERATOR AS SECOND TERM FOLLOWING A \$L, \$E, \$G	THIS SEARCH IS BYPASSED, NOTHING ON OUTPUT TAPE. REWRITE THE QUESTION.
ERROR 9	SECOND FIELD OF THE NUMERICAL OPERATOR IS NON-NUMERICAL	THIS SEARCH IS BYPASSED, NOTHING ON OUTPUT TAPE. REWRITE THE QUESTION.
ERROR 10	SECOND FIELD OF THE NUMERICAL OPERATOR IS LESS THAN THE FIRST FIELD	THIS SEARCH IS BYPASSED, NOTHING ON OUTPUT TAPE. REWRITE THE QUESTION.

ALL OTHER MESSAGES WHICH MAY OCCUR ARE SELF-EXPLANATORY.

\*\*\*\*\*  
 INTRODUCTION  
 \*\*\*\*\*

THE SORT PROGRAM IS DESIGNED TO REARRANGE THE CONTENTS OF A TAPE FILE IN AN ORDER SPECIFIED BY A SUBFIELD OF EACH ITEM OF THE FILE.

\*\*\*\*\*  
 THE SORT KEY  
 \*\*\*\*\*

THE ORDER CONTROLLING SUBFIELD OF EACH ITEM IS CALLED THE SORT KEY. THE SORT KEY MAY OCCUR AT ANY POSITION IN THE ITEM, HOWEVER IT MUST OCCUR AT THE SAME POSITION IN EVERY ITEM OF THE FILE. ALSO, THE SORT KEY MAY BE AS LONG AS DESIRED. IT IS ASSUMED TO BE CONTINUOUS WITH THE MOST SIGNIFICANT PART OF THE KEY FURTHEST TO THE LEFT.

ITEMS WHICH HAVE THE SAME SORT KEY MAY NOT OCCUR IN THE SAME ORDER RELATIVE TO EACH OTHER ON THE OUTPUT TAPE AS THEY WERE ON THE INPUT TAPE.

ALSO, ITEMS WHICH HAVE THE SAME SORT KEY MAY BE DELETED, MAINTAINING ONLY ONE OF THE ITEMS, BY AN APPROPRIATE OPTION ON THE SORT DATA CARD AS DESCRIBED LATER.

\*\*\*\*\*  
 THE SORT CODE  
 \*\*\*\*\*

THE SORT CODE SPECIFIES THE TYPE OF COMPARISON TO BE MADE ON THE SORT KEY OR THE COLLATING SEQUENCE TO BE USED. THERE ARE THREE CHOICES.

A NUMERICAL SORT ASSUMES THAT THE SORT KEY IS NUMERICAL DATA AND COMPARES IT IN THE USUAL WAY ACKNOWLEDGING THE SIGN BIT.

THE 7090/94 LOGICAL SORT ASSUMES THAT THE SORT KEY IS A STRING OF BITS AND COMPARES THEM STRICTLY ON MAGNITUDE WITH NO REGARD FOR SIGN. IF THE SORT KEY IS ACTUALLY A STRING OF CHARACTERS, THEN THEY ARE ESSENTIALLY SORTED ACCORDING TO THE 7090/94 COLLATING SEQUENCE - COLUMN 2 OF TABLE 1.

THE 1401 COLLATING SEQUENCE SORT ASSUMES THAT THE SORT KEY IS A STRING OF CHARACTERS AND COMPARES THEM ACCORDING TO THE STANDARD 1401 COLLATING SEQUENCE - COLUMN 1 OF TABLE 1.

\*\*\*\*\*  
 THE SORT DATA CARD  
 \*\*\*\*\*

IT IS NECESSARY TO SPECIFY CERTAIN CONTROL INFORMATION TO THE SORT PROGRAM SUCH AS SORT KEY POSITION AND LENGTH, SORT CODE, ETC. THIS IS DONE VIA THE SORT DATA CARD.

THE DATA CARD IS PUNCHED AS FOLLOWS BEGINNING IN COLUMN 1 WITH NO INTERVENING BLANKS.

\$MRS,NCS,FCP,SC,TM,DD,IT,OT,ST1,ST2,ST3

ERE -

- MRS = MAXIMUM RECORD SIZE IN CHARACTERS (1 CHAR. = 6 BITS, 6 CHARS. = 1 MACHINE WORD).
- NCS = NUMBER OF CHARACTERS IN SORT KEY.
- FCP = FIRST CHARACTER POSITION IN EACH ITEM OF THE SORT KEY.
- SC = THE SORT CODE (AS EXPLAINED EARLIER).
  - 1 = NUMERICAL SORT
  - 2 = 7090/94 LOGICAL SORT
  - 3 = 1401 COLLATING SEQUENCE SORT
- TM = A CODE SPECIFYING TAPE MODE.
  - 0 = UNBLOCKED
  - 1 = BLOCKED
- DD = A DUPLICATE DELETION CODE
  - 0 = OUTPUT ALL RECORDS
  - 1 = OUTPUT ONLY ONE RECORD OF A SET OF RECORDS WITH THE SAME SORT KEY.
- IT = SYMBOLIC TAPE NAME OF INPUT TAPE
- OT = SYMBOLIC TAPE NAME OF OUTPUT TAPE
- ST1 = SYMBOLIC TAPE NAME OF SCRATCH TAPE
- ST2 = SYMBOLIC TAPE NAME OF SCRATCH TAPE
- ST3 = SYMBOLIC TAPE NAME OF SCRATCH TAPE

INITIALLY, ALL TAPES EXCEPT THE INPUT TAPE ARE REWOUND. AT THE END OF THE TAPE SORT ALL TAPES ARE REWOUND.

\*\*\*\*\*  
 USAGE OF THE SYSTEM  
 \*\*\*\*\*

IN GENERAL, ONE OF THE MAIN PROBLEMS ASSOCIATED WITH USING COMPUTERS, ESPECIALLY ON A LARGE SCALE AS AT OUR INSTALLATION, IS THE TIME LAPSE BETWEEN SUBMITTING A JOB TO BE RUN AND RECEIVING THE RESULTS. THUS, IT IS DESIRABLE TO DO AS MUCH DURING ONE ACCESS TO THE COMPUTER AS POSSIBLE. TO ACCOMPLISH THIS END, IPS IS DESIGNED SO THAT ANY OR ALL OF THE PROGRAMS BELONGING TO IT MAY BE RUN DURING ONE TIME ON THE COMPUTER, IN ANY ORDER DETERMINED BY THE USER AND AS MANY TIMES AS NEEDED.

IT IS IMPORTANT THAT THE USER BE FAMILIAR WITH THE GENERAL CHECK SETUP FOR IPS AND UNDERSTAND THE NECESSARY CONTROL CARDS FOR THE SYSTEM. A MORE GENERAL DISCUSSION WILL BE FOUND IN BCC-351, WHICH DESCRIBES THE INFORMATION PROCESSING SYSTEM (OF WHICH THE SEARCH AND SORT PROGRAMS ARE ONLY A PART) AS A UNIT.

FIRST IT IS NECESSARY TO IDENTIFY YOURSELF TO THE SYSTEM AND PROVIDE CERTAIN BOOKKEEPING INFORMATION. THIS IS ACCOMPLISHED WITH THE 'JOB' CARD PUNCHED AS FOLLOWS.

THE 7094 SORT PROGRAM  
USAGE OF THE SYSTEM

14

COL. 1 - THE PUNCHES 7,8,9  
COLS. 8-10 - THE WORD 'JOB'  
COLS. 16- - JOB NUMBER,P, YOUR NAME, ESTIMATED TIME IN HUNDREDS OF HOURS, 999999, 10000

FOR EXAMPLE

JOB 1023,P,DOE,20,999999,10000

NEXT THE SYSTEM MUST BE TOLD WHICH TAPE DRIVES (OR AUXILIARY STORAGE MEDIUM) ARE TO BE USED AND THE OPERATOR INFORMED OF WHAT FILES TO BE MOUNTED. THIS IS ACCOMPLISHED BY THE 'ASSIGN' CARD AS FOLLOWS

COL. 1 - THE PUNCHES 7,8,9  
COLS. 8-13 - THE WORD 'ASSIGN'  
COLS. 16-24 - THE STRING 'CK=SYSXZN' WHERE CK IS THE PHYSICAL UNIT TO BE USED AND SYSXZN IS THE SYMBOLIC NAME REFERENCED BY THE PROGRAM.  
COLS. 26- - COMMENTS TO THE OPERATOR SUCH AS TAPE TO MOUNT.

FOR EXAMPLE

ASSIGN A5=SYSAR4 MOUNT TAPE NO. 100

THE USER SHOULD CHECK WITH THE PERSON TO WHOM HE SUBMITS HIS JOB TO BE SURE THAT THE PHYSICAL HARDWARE (SUCH AS TAPE DRIVES) WHICH HE IS REQUESTING IS AVAILABLE.

NOW IT IS TIME TO GET IPS INTO THE MACHINE. THE FOLLOWING CARD, CALLED AN 'LBRL' CARD, ACCOMPLISHES THIS.

COL. 1 - THE PUNCHES 7,8  
COLS. 8-11 - THE WORD 'LBRL'  
COLS. 16-21 - THE WORD 'INPACK' (FOR INFORMATION PACKAGE)

FOR EXAMPLE

LBRL INPACK

THE SEARCH OR SORT PROGRAM IS OBTAINED BY TWO SUCCESSIVE CARDS, NAMELY 'DATA' AND 'SEARCH' OR 'SORT'. THE 'DATA' CARD IS PUNCHED

COL. 1 - THE PUNCHES 7,8,9  
COLS. 8-11 - THE WORD 'DATA'  
COLS. 16-21 - THE WORD 'NOEDIT'

THE NEXT CARD MUST BE PUNCHED AS FOLLOWS

COLS. 8-13 - THE WORD 'SEARCH' OR 'SORT'  
COLS. 16- - A,B

SORT PROGRAM  
OF THE SYSTEM

15

IS 'GOIF' TO EXECUTE THIS PROGRAM REGARDLESS OF PREVIOUS  
OF JOBS IN THIS BATCH.  
S 'GOIFIF' TO EXECUTE THIS PROGRAM ONLY IF PREVIOUS 'GOIF'  
'IF' JOBS HAVE HAD NO ERRORS.  
IS 'SYSXZN' SPECIFYING THE TAPE UNIT CONTAINING THE NEXT  
TO EXECUTE.

NORMAL CASE FOR 'A,B' IS 'GOIFIF,SYSMIT' AND THIS IS  
IF 'A,B' IS OMITTED.

OWING THIS CARD MUST BE THE SEARCH REQUEST DECK OR SORT  
RD, DEPENDING ON THE PROGRAM. FOR EXAMPLE, THE FOLLOWING  
TYPICAL DECK SETUP FOR THE SEARCH PROGRAM FOLLOWED BY THE  
OGRAM TO LIST THE RESULTS.

```
JOB      NO.,P,DOE,20,999999,10000
ASSIGN  A4=SYSAR4      MOUNT TAPE XXX
ASSIGN  A5=SYSAR5      MOUNT BLANK TAPE - SAVE
ASSIGN  A6=SYSAU4      MOUNT SCRATCH TAPE
LBRL    INPACK
DATA    NOEDIT
SEARCH
ION 3600,1,0,0,0,SYSAU4,SYSAU4,SYSAU4,SYSES1,SYSES2,SYSES3
PE CARDS, IF USED)
RMAT AND SEARCH REQUEST CARDS)
LBRL    PRINT
SAR5
01
```

THE 7094 SORT PROGRAM  
 TABLE 1 - CHARACTER REPRESENTATION

SEQ NO.	DCT REP.	CARD REP.	CHARACTER	SEQ NO.	BIN REP.	CARD REP.	CHARACTER
00	60		BLANK	32	27	+7	G
01	33	+38	.	33	30	+8	H
02	34	+48	)	34	31	+9	I
03	35	+58	LEFT BRACKET	35	52	-0	- MINUS ZERO
04	36	+68	LESS THAN	36	41	-1	J
05	37	+78	GROUP MARK	37	42	-2	K
06	20	+	+	38	43	-3	L
07	53	-38	\$	39	44	-4	M
08	54	-48	*	40	45	-5	N
09	55	-58	RIGHT BRACKET	41	46	-6	O
10	56	-68	SEMICOLON	42	47	-7	P
11	57	-78	MODE CHANGE	43	50	-8	Q
12	40	-	-	44	51	-9	R
13	61	01	/	45	72	028	+ RECORD MARK
14	73	038	,	46	62	02	S
15	74	048	(	47	63	03	T
16	75	058	WORD SEPARATOR	48	64	04	U
17	76	068	NON PRINTING	49	65	05	V
18	77	078	TAPE SEGMENT	50	66	06	W
19	60	28	A-BIT	51	67	07	X
20	13	38	=	52	70	08	Y
21	14	48	' APOSTROPHE	53	71	09	Z
22	15	58	COLON	54	00	0	0
23	16	68	GREATER THAN	55	01	1	1
24	17	78	RADICAL	56	02	2	2
25	32	+0	+ PLUS ZERO	57	03	3	3
26	21	+1	A	58	04	4	4
27	22	+2	B	59	05	5	5
28	23	+3	C	60	06	6	6
29	24	+4	D	61	07	7	7
30	25	+5	E	62	10	8	8
31	26	+6	F	63	11	9	9

Reference Search - List of Searches

- OPTION 1
- JPC.1,0, AERONAUTICS. FABRICATION/MATERIALS/UTILIZATION/AVIATION/U//
- JPC.2,0, AGRICULTURE. MANUFACTURING/U//
- JPC.3,0, ASTRONOMY. FABRICATION/MATERIALS/UTILIZATION/U//
- JPC.4,0, ATMOSPHERE. FABRICATION/MATERIALS/UTILIZATION/U//
- JPC.5,0, SOCIAL SCI. FACTORING/STATISTICS/TECHNOLOGY/HUMAN ENGINEERING/ECONOMIC/HISTORY/GISTICS/PSYCHOLOGY/MANAGEMENT/DEVICES/TECHNOLOGY/U//
- JPC.6,0, BIOLOGY. FABRICATION/ELECTRONICS/PHOTONICS/PHYSIOLOGY/U//
- JPC.7,0, CHEMISTRY. MANUFACTURING/U//
- JPC.8,0, EARTH SCIENCES/GEOPHYSICS/CLIMATOLOGY/ATMOSPHERIC SCIENCE/AGRICULTURE/AGRICULTURE/AGRICULTURE/U//
- JPC.9,0, ELECTRONICS. FABRICATION/ELECTRONICS/ELECTRICAL/ELECTRONICS/U//
- JPC.10,0, ENERGY. FABRICATION/SUPPLY/U//
- JPC.11,0, MATERIAL. FABRICATION/MATERIALS/UTILIZATION/MATERIALS/ADHESIVE/CERAMIC/GLASS/COATING/FIBER METALURGY/METALLURGY/UTILE/UTILIZATION/PLASTIC/PAINT/SOLVENT/U//

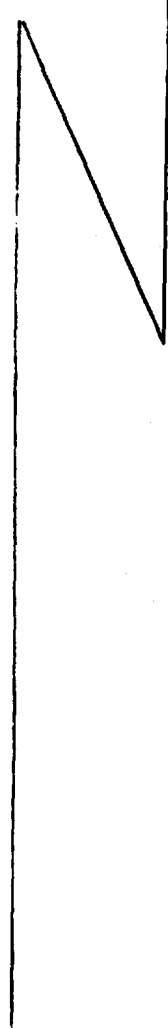

- S20.2,900. FABRICATION/ELECTRONICS/PHOTONICS/PHYSIOLOGY/U//
- S20.3,900. FABRICATION/MATERIALS/UTILIZATION/MATERIALS/ADHESIVE/CERAMIC/GLASS/COATING/FIBER METALURGY/METALLURGY/UTILE/UTILIZATION/PLASTIC/PAINT/SOLVENT/U//
- S20.4,900. FABRICATION/MATERIALS/UTILIZATION/MATERIALS/ADHESIVE/CERAMIC/GLASS/COATING/FIBER METALURGY/METALLURGY/UTILE/UTILIZATION/PLASTIC/PAINT/SOLVENT/U//

C-10

Reference Search Question

1

112.37140, P.K. HILL.  
1/25A/COMPENSIBLE/SUNDAY/LAYER/

Best Available Copy



**APPENDIX D**

**GRAPHICS STORAGE AND RETRIEVAL**



D-3

Graphics Index Printout  
Sample

448		69219	U		ADD-EDK	
605	MAY 1958	31732	U		SDD	BR 2757
718	NO DATE	50250	U		BBW-FLN	BBW/CF
807	NO DATE	70386	U		ADD-EDK	
3730	JUN 1965	70432	U		CLU	
3747	JUN 1965		U	70429	CLU	
3749	JUN 1965		U	70430	CLU	

VISUAL AID INDEX

BY ORIGINATOR

ORIGINATOR	ORIG NO	VA NO	DATE	NEG NO	NEG CIL	CLASS ST	PRES
CLU		3730	JUN 1965	70432			
CLU		3747	JUN 1965	70429			
CLU		3749	JUN 1965		70430		
CLU-NEG	RPL 101	1	JUL 1963	66748			U
TAD	CH 16	349	JUL 1962	53181	55218		
BPU-JHW	RPL 157A	6A	MAY 1958	33770			U
CLU	CLL 549 1	235	NO DATE	40674			C
FSU-LWF	RPL 115	2	JAN 1962	49439			C
SDD			NO DATE	37418			U
TAD	RPL 362F	307F	MAY 1956	25019			U
TEL-JFR	RPL 150K	3K	OCT 1961	44892	48502		C
TLG	RPL 658A	59A	MAY 1960	43357			C
TAD-SJA		274	NO DATE	46294			C

VISUAL AID INDEX

BY BLACK AND WHITE NEGATIVE NUMBER

NEG NO	NEG CIL	CLASS ST	PRES	ORIGINATOR	ORIG NO	VA NO	DATE
25019		U		TAD	RPL 362F	307F	MAY 1956

Best Available Copy

**APPENDIX E**  
**THESAURUS SAMPLES**

## List of Terms

A

A (CHEMICAL ELEMENT)  
 USE  
 ARGON

\*A-11-B  
 (SOLID PROPELLANT)  
 USE ALSO  
 SOLID/PROPELLANT

\*A-7-C  
 (SOLID PROPELLANT)  
 USE ALSO  
 PROPELLANT

\*AAJAC  
 (AUTOMATIC ANTI-JAMMING CIRCUITRY)

\*AAJAC MATE  
 (RADAR)

AAM  
 (AIR-TO-AIR MISSILE)  
 USE ALSO  
 MISSILE

AAW  
 (ANTI-AIR WARFARE)  
 USE ALSO  
 WAR

ABERRATION (OPTICS)

ABILITY  
 (HUMAN QUALITIES)  
 SEE ALSO  
 CAPABILITY (FOR EQUIPMENT)

ABLATING (ADJ.)

ABLATION  
 SEE ALSO  
 COOLING  
 HEAT/TRANSFER  
 SUBLIMATION  
 VAPORIZATION

ABLATIVE MATERIAL  
 USE  
 ABLATING/MATERIAL

ABLATOR  
 USE  
 ABLATING/MATERIAL

\*ABLE  
 (A.F./NASA. BOOSTER, PHASED OUT 1961)  
 USE ALSO  
 BOOSTER

ABNORMAL (PHYSIOLOGY)

ABM  
 (ANTIBALLISTIC MISSILE)  
 USE ALSO  
 MISSILE

ABORT  
 (PERMATURE AND ABRUPT TERMINATION OF MISSION)

ABRUPT (ADJ.)

ABSCISSA (MATHEMATICS)  
 (THE HORIZONTAL COORDINATE OF A POINT  
 IN A TWO-DIMENSIONAL SYSTEM)

A

AAB ARMY ARTILLERY BOARD, FT. SILL, OKLAHOMA  
 AACL ANDREW ALFORD CONSULTING ENGINEERS, BOSTON, MASS.  
 AAKRU ARMY AVIATION HUMAN RESEARCH UNIT, FT. RUCKER, ALA.  
 AAI AIRCRAFT ARMAMENTS, INC.  
 ABAC AMERICAN BOSCH ARMS CORP., GARDEN CITY, N.J.  
 ABL ALLEGANY BALLISTICS LAB, CUMBERLAND, MD  
 ABLAB ARMY BIOLOGICAL LAB, FT. DETRICK, MD.  
 ACAC ARMY CONTINENTAL ARMY COMMAND, FT. MONROE  
 ACDC ARMY COMBAT DEVELOPMENT COMMAND.  
 ACL ARMY CORPS OF ENGINEERS  
 ACF ACF INDUSTRIES, INC., HYATTSVILLE, MD.  
 AGRH ARGONNE CANCER RESEARCH HOSPITAL  
 AGRREL ARMY COLD REGIONS R+E LAB., HANOVER, N.H.  
 AD AGRICULTURE DEPT  
 AD-F AGRICULTURE DEPT., FOREST SERVICE  
 ADAPT ADAPTRONICS, INC., ALEXANDRIA, VA.  
 ADCOM ACCOM, INC., CAMBRIDGE, MASS.  
 ADELPHI ADELPHI UNIVERSITY  
 ADELRC ADELPHI RESEARCH CENTER  
 ADL ARTHUR D LITTLE, INC., CAMBRIDGE, MASS.  
 ADLI ADVANCED DEVELOPMENT LABS. INC.  
 AEC ATOMIC ENERGY COMMISSION.  
 AECOM ARMY ELECTRONICS COMMAND  
 AEDC ARNOLD ENGINEERING DEVELOPMENT CENTER  
 AEI ASSOCIATED ELECTRICAL INDUSTRIES, LTD.  
 AEON AEON LABORATORIES, SURRY, ENGLAND  
 AEPG ARMY ELECTRONIC PROVING GROUND, FT. HUACHUCA, ARIZ.  
 AERD ARMY ENGINEER R + D LAB, FT. BELVOIR, VA.  
 AERDA ARMY ELECTRONICS R+D ACTIVITY, WSMR  
 AERDL ARMY ELECTRONICS R + D LAB., FT. MONMOUTH, N.J.  
 AEROCHEM AEROCHEM RESEARCH LABS, INC., PRINCETON, N.J.  
 AEROFLEX AEROFLEX LABS, INC, PLAINVIEW, L.I., N.Y.  
 AEROJET AEROJET-GENERAL CORP, AZUSA, CALIF  
 AERON AERONAUTICAL RESEARCH COUNCIL  
 AERLNUC AERONUTRONIC, DIV OF PHILCO CO., NEWPORT BEACH, CAL.  
 AFA FRANKFORD ARSENAL, U.S. ARMY, PHILADELPHIA, PA.  
 AFACIC A.F. AERONAUTICAL CHART AND INFO. CTR., ST. LOUIS  
 AFAL A.F. AVIONICS LABORATORY  
 AFAMAC A.F. AIR MATERIEL COMMAND  
 AFAMC A.F. AEROSPACE MEDICAL CENTER, BROOKS AFB, TEXAS  
 AFAMD A.F. AEROSPACE MEDICAL DIV, BROOKS A.F.B.  
 AFAMRL A.F. AEROSPACE MEDICAL RESEARCH LABS, AFSC.  
 AFAPL A.F. AERD PROPULSION LABORATORY, AFSC, W-P, AFB.  
 AFARDC A.F. AIR RESEARCH + DEVELOPMENT COMMAND  
 AFARL A.F. AEROSPACE RESEARCH LABS.  
 AFASD A.F. AERONAUTICAL SYSTEMS DIV, W-P AFB.  
 AFATC A.F. AIR TRAINING COMMAND, SCOTT AFB  
 AFBSD A.F. BALLISTIC SYSTEMS DIV., WORTON AFB  
 AFCAD A.F. ACADEMY, COLORADO SPRINGS, COLORADO  
 AFCRL A.F. CAMBRIDGE RESEARCH LABS., BEDFORD, MASS.  
 AFESD A.F. SYSTEMS COMMAND - ELECTRONICS SYSTEMS DIV.  
 AFETR A.F. EASTERN TEST RANGE  
 AFFTD A.F. FOREIGN TECHNOLOGY DIVISION, W-P AFB.  
 AFWALC A.F. WRIGHT AIR DEVELOPMENT CENTER

SOURCE BY TITLE

30 NOVEMBER 1965

SOURCE

CODE

A

ACADEMY OF SCIENCES, NATIONAL RESEARCH COUNCIL	AS-NRC
ACF INDUSTRIES, INC., HYATTSVILLE, MD.	ACF
ADAPTRONICS, INC., ALEXANDRIA, VA.	ADAPT
ADCOM, INC, CAMBRIDGE, MASS.	ADCOM
ADELPHI RESEARCH CENTER	ADELRC
ADELPHI UNIVERSITY	ADELPHI
ADMIRALTY ENG. LAB, W. DRAYTON, MIDDLESEX	GTB-AEL
ADMIRALTY RESEARCH LAB. TEDDINGTON, MIDDLESEX	GTB-ARL
ADMIRALTY UNDERWATER WEAPONS ESTAB.	GTB-AUN
ADVANCED DEVELOPMENT LABS, INC.	ADLI
ADVANCED ENGINE + TECHNOLOGY DEPT., G.E.	GE-AE1D
ADVANCED METALS RESEARCH CORP, MASS.	AMRC
ADVANCED RESEARCH PROJECTS AGENCY.	ARPA
ADVANCED TECHNOLOGY CORP, TIMONIUM, MD.	ATC
ADVANCED TECHNOLOGY LABS, G.E.	GE-ATL
ADVISORY GROUP FOR AERONAUTICAL R&D, PARIS	AGARD
OF NORTH ATLANTIC TREATY ORGANIZATION	NATO
AEON LABORATORIES, SURRY, ENGLAND	AEON
AEROCHEM RESEARCH LABS, INC, PRINCETON, N.J.	AEROCHEM
SUBIDIARY OF PFAUDLER PERMUTIT, INC.	PP1
AEROFLEX LABS, INC, PLAINVIEW, L.I., N.Y.	AEROFLEX
AEROJET-GENERAL CORP, AZUSA, CALIF	AEROJET
AERONAUTICAL RESEARCH ASSOCIATES	ARAP
OF PRINCETON INC.	
AERONAUTICAL RESEARCH COUNCIL	AERON
AERONAUTICAL RESEARCH INST. OF SWEDEN	FFA
AERONUTRONIC, DIV. OF PHILCO, NEWPORT BEACH	AERONUT
AEROSPACE CORP., EL SEGUNDO, CALIF.	ASC
AERODYNAMICS + PROPULSION RESEARCH LAB.	
AEROSPACE INDUSTRIES ASSOCIATION	ATAAI
OF AMERICA INC, WASHINGTON, D.C.	
AEROSPACE RESEARCH ASSOC. INC, A. COVINA, CALIF	APAI
AEROSPACE RESEARCH LAB	ARL
HYPERSONIC RESEARCH LAB.	
OFFICE OF AEROSPACE RESEARCH	
AEROSYSTEMS INTERNATIONAL, INC. FAIRCHILD, N.J.	ASINC
AGRICULTURE DEPT	AD
FOREST SERVICE	AD-F
FOREST PRODUCTS LAB	
AIR FORCE-	
A.F. ACADEMY, COLORADO SPRINGS, COLORADO	AFCAD
A.F. AERONAUTICAL CHART AND INFO. CTR. ST. LOUIS	AFACIC
A.F. AERONAUTICAL SYSTEMS DIV, W-P AFB	AFASD
A.F. AERO PROPULSION LAB, AFSC, W-P AFB	AFAPL
A.F. AEROSPACE MEDICAL CENTER, BROOKS AFB	AFAMC
A.F. AEROSPACE MEDICAL DIV. BROOKS A.D.B.	AFAMD
A.F. AEROSPACE MEDICAL RESEARCH LABS, AFSC	AFAMRL
A.F. AEROSPACE RESEARCH LABS.	AFARL
A.F. AIR MATERIEL COMMAND	AFAMAC

**APPENDIX F**  
**EDIT PROGRAM**



TO - DISTRIBUTION  
FROM - R. P. RICH  
SUBJECT- 7094 EDIT PROGRAM

TABLE OF CONTENTS

INTRODUCTION.....  
THE CHANGE DECK.....  
CONTROL CARD FORMAT.....  
TREATMENT OF RIGHT END.....  
RECORD NUMBER PARAMETERS.....  
A-CARD. \$F1,F2,A SET A-TAPE.....  
B-CARD. \$F1,F2,B SET B-TAPE.....  
D-CARD. \$F1,F2,D DELETE RECORDS.....  
E-CARD. \$F1,E END CARD.....  
F-CARD. \$F1,F2,F FORMAT CARD.....  
I-CARD. \$F1,I,TEXT INDENTED PARAGRAPH INSERTION.....  
J-CARD. \$F1,J JOIN RECORDS.....  
K-CARD. \$K,TEXT AUTO-KEY INSERTION.....  
L-CARD. \$F1,L,TEXT LINE FOR LINE INSERTION.....  
NA-CARD. \$=SYSXZNS,NA NAME A-TAPE.....  
NB-CARD. \$=SYSXZNS,NB NAME B-TAPE.....  
NO-CARD. \$=SYSXZNS,NO NAME OUTPUT TAPE.....  
NT-CARD. \$=SYSXZNS,NT NAME CHANGE TAPE.....  
O-CARD. \$F1,O,TEXT OVERHANGING PARAGRAPH INSERTION.....  
P-CARD. \$F1,F2,F3,P NEW PARAGRAPH.....  
R-CARD. \$F1,F2,F3,R,TEXT REPLACE BY BOUNDARIES.....  
S-CARD. \$F1,F2,S,TEXT SUBSTITUTION IN ALL RECORDS.....  
SD-CARD. \$F1,F2,SD,TEXT SUBSTITUTE IN ONE RECORD.....  
SX-CARD. \$F1,SX TURN OFF S-CARDS.....  
T-CARD. \$F1,F2,T CHANGES ON TAPE.....  
TX-CARD. \$F1,F2,TX TURN OFF T-CARD.....  
U-CARD. \$F1,U,TEXT SUBSTITUTE IN CARDS.....  
UX-CARD. \$UX TURN OFF U-CARDS.....  
V-CARD. \$V VERIFY CARD ORDER.....  
VX-CARD. \$VX TURN OFF V-CARD.....  
Y-CARD. \$F1,....,Y,TEXT YOUR ROUTINE.....  
JOB DECK SETUP.....

\*\*\*\*\*  
 INTRODUCTION  
 \*\*\*\*\*

THE EDIT PROGRAM HERE DESCRIBED IS WRITTEN IN THE MANIPULATOR LANGUAGE FOR THE IBM 7094 COMPUTER, AND IS CONSISTENT WITH THE OTHER PROGRAMS OF THE 7094 INFORMATION PACKAGE.

THIS PROGRAM PERMITS THE INITIAL ESTABLISHMENT OR LATER MODIFICATION OF A STANDARD INFORMATION FILE.

A STANDARD FILE CONSISTS OF ONE OR MORE STANDARD RECORDS, ALL ON ONE MAGNETIC TAPE, FOLLOWED BY A FILE MARK.

A STANDARD RECORD CONSISTS OF A FIVE-DIGIT RECORD NUMBER (CONSECUTIVE STARTING AT 00001), FOLLOWED BY TWO FORMAT CONTROL CHARACTERS (WHOSE USE IS DESCRIBED IN THE 'PRINT' WRITE-UP), FOLLOWED BY THE TEXT OF THE RECORD (WITH TRAILING BLANKS AND DOLLAR SIGNS OMITTED), FOLLOWED BY A DOLLAR SIGN. THE TOTAL NUMBER OF CHARACTERS IN A RECORD MUST BE LESS THAN 10,000.

A DECK OF CHANGE CARDS (DESCRIBED IN DETAIL BELOW) SPECIFIES WHAT IS TO BE ON THE OUTPUT TAPE. IT MAY REFER TO AS MANY AS TWO INPUT TAPES (CALLED THE 'A-TAPE' AND 'B-TAPE' RESPECTIVELY). IF SO, EACH INPUT TAPE REFERRED TO MUST BE A STANDARD INFORMATION FILE AS DESCRIBED ABOVE. THE OUTPUT TAPE WILL ALWAYS CONSTITUTE A STANDARD INFORMATION FILE.

ANY RECORD ON THE NEW TAPE WHICH HAS BEEN EITHER ADDED OR CHANGED WILL BE PRINTED FOR CHECKING PURPOSES.

\*\*\*\*\*  
 THE CHANGE DECK.  
 \*\*\*\*\*

THE CHANGE DECK, WHICH SPECIFIES WHAT IS TO BE DONE DURING THIS RUN, CONSISTS OF CONTROL CARDS AND FREE TEXT CARDS. THE LAST CARD OF THE CHANGE DECK SHOULD ALWAYS BE AN E-CARD (SEE ALPHABETIC LIST OF CONTROL CARDS BELOW).

A CONTROL CARD ALWAYS HAS A DOLLAR SIGN IN COLUMN 1. A FREE TEXT CARD NEVER HAS A DOLLAR SIGN IN COLUMN 1. FREE TEXT CARDS NEVER OCCUR UNLESS IMMEDIATELY PRECEDED BY A CONTROL CARD SPECIFYING WHAT IS TO BE DONE WITH THE FREE TEXT, AND THE FORMAT OF THE FREE TEXT CARDS MUST BE THAT SPECIFIED BY THE GOVERNING CONTROL CARD.

\*\*\*\*\*  
 CONTROL CARD FORMAT.  
 \*\*\*\*\*

ALL CONTROL CARDS HAVE THE FOLLOWING FORMAT. COLUMN 1 IS A DOLLAR SIGN. THIS IS FOLLOWED BY THE PARAMETER FIELDS (IF ANY), FOLLOWED BY A CONTROL CODE (REQUIRED IN ALL CASES), FOLLOWED BY THE TEXT FIELD (IF ANY). NOTICE THAT THE WHOLE CONTROL STRING, FROM THE INITIAL DOLLAR SIGN THROUGH THE CONTROL CODE, MUST BE ON THE SAME CARD. THE TEXT FIELD (IF ANY) MAY BE CONTINUED ONTO FOLLOWING CARDS AS DESCRIBED BELOW.

THE PARAMETER FIELDS MAY BE EITHER NUMERIC OR LITERAL (DEPEN-

F (continued)

7094 EDIT PROGRAM

2

DING ON THE SPECIFICATIONS FOR THE TYPE OF CONTROL CARD).

A NUMERIC PARAMETER FIELD CONSISTS OF A SEQUENCE OF DECIMAL DIGITS, WITH THE USUAL INTERPRETATION. LEADING ZEROS NEED NOT BE WRITTEN, AND BLANKS MAY BE USED AS DESIRED EITHER TO THE LEFT OR TO THE RIGHT OF THE DIGIT STRING. A VACUOUS STRING IS INTERPRETED AS ZERO.

A LITERAL PARAMETER FIELD CONSISTS OF AN EQUAL SIGN (=), FOLLOWED BY A STRING OF CHARACTERS NONE OF WHICH IS A DOLLAR SIGN (\$), FOLLOWED BY A DOLLAR SIGN. BLANKS MAY BE USED AS DESIRED EITHER TO THE LEFT OF THE EQUALS SIGN OR TO THE RIGHT OF THE DOLLAR SIGN, AND WILL BE IGNORED. BUT BLANKS BETWEEN THE EQUALS SIGN AND THE DOLLAR SIGN FORM PART OF THE LITERAL STRING AND ARE TREATED LIKE ANY OTHER CHARACTER OF THE STRING.

A COMMA SHOULD BE WRITTEN BETWEEN TWO SUCCESSIVE PARAMETER FIELDS, BETWEEN THE LAST PARAMETER FIELD AND THE CODE, AND BETWEEN THE CONTROL CODE AND THE TEXT FIELD (IF ANY). IF THE LAST ONE OR MORE PARAMETER FIELDS ARE NULL THEN NEITHER THE FIELD NOR ITS FOLLOWING COMMA HAS TO BE WRITTEN.

BLANKS MAY BE USED AS DESIRED ON EITHER SIDE OF THE FIELD CHARACTERS, AND ARE IGNORED.

IF A TEXT FIELD OCCURS ON A CONTROL CARD, IT STARTS IMMEDIATELY TO THE RIGHT OF THE COMMA WHICH SEPARATES IT FROM THE CONTROL CODE. THE RIGHT TEXT END OF THE TEXT FIELD IS DETERMINED IN THE SAME WAY AS FOR FREE TEXT CARDS (SEE NEXT PARAGRAPH).

\*\*\*\*\*  
TREATMENT OF RIGHT END.  
\*\*\*\*\*

WHEN CARDS WITH TEXT ON THEM (WHETHER THE TEXT FIELD OF A CONTROL CARD OR A FREE TEXT CARD) ARE BEING PREPARED, IT IS CONVENIENT TO BE ABLE TO END AT A NATURAL PLACE IN THE TEXT RATHER THAN AT A SPECIFIED CARD COLUMN. THE FOLLOWING CONVENTIONS HAVE THEREFORE BEEN ADOPTED FOR ALL TEXT CARDS.

ALL BLANKS AND DOLLAR SIGNS ARE ELIMINATED FROM THE RIGHT END OF THE CARD LEFTWARD TO THE FIRST CHARACTER WHICH IS NEITHER ONE. CALL THAT CHARACTER THE SIGNIFICANT CHARACTER.

IF THE SIGNIFICANT CHARACTER IS A HYPHEN, THEN IT IS ELIMINATED.

IF THE SIGNIFICANT CHARACTER IS NOT A HYPHEN, THEN ONE BLANK IS ADDED TO THE RIGHT OF IT.

THESE RULES MEAN THAT IF YOU WANT TO PRESERVE BLANKS, DOLLAR SIGNS, OR HYPHENS AT THE RIGHT END OF A TEXT CARD THEN YOU MUST GUARD THEM FROM ERASURE BY A HYPHEN ON THEIR RIGHT.

\*\*\*\*\*  
RECORD NUMBER PARAMETERS.  
\*\*\*\*\*

SOME PARAMETER FIELDS DESIGNATE RECORDS ON THE ACTIVE INPUT TAPE. UNLESS THE CONTRARY IS EXPLICITLY STATED, SUCH FIELDS, ALTHOUGH CALLED 'RECORD NUMBERS', MAY BE EITHER NUMERIC OR LITERAL.

IF A RECORD NUMBER FIELD IS NUMERIC, IT REFERS TO THAT NUMBER RECORD ON THE INPUT TAPE, AS DETERMINED BY COUNTING RECORDS FROM

F (continued)

7094 EDIT PROGRAM

THE BEGINNING OF THE TAPE (NOT BY INSPECTING THE FIRST FIVE CHARACTERS OF EACH RECORD).

IF A RECORD NUMBER FIELD IS LITERAL, THEN THE STRING WITH THE SAME NUMBER OF CHARACTERS, STARTING IN POSITION EIGHT OF EACH INPUT RECORD, IS INTERPRETED AS A SEQUENCE CODE, AND COMPARED WITH THE GIVEN STRING. IN THIS CASE THE (RELEVANT PORTION OF THE) INPUT TAPE MUST BE IN ORDER BY ITS SEQUENCE CODES.

IF A RECORD NUMBER FIELD IS NULL, THEN USUALLY NOTHING HAPPENS TO THE INPUT TAPE, BUT WATCH FOR EXCEPTIONS.

\*\*\*\*\*  
A-CARD. \$F1,F2,A  
\*\*\*\*\*

THE A-CARD DESIGNATES TAPE A AS THE ACTIVE INPUT TAPE. THIS DESIGNATION REMAINS IN EFFECT UNTIL A B-CARD IS MET. TAPE A IS AUTOMATICALLY ASSUMED TO BE THE ACTIVE INPUT TAPE UNTIL THE FIRST A-CARD OR B-CARD OCCURS.

IF FIELD F1 IS NOT NULL THEN THE TAPE IS MOVED INTO POSITION TO READ RECORD NUMBER F1. IF F1 IS NUMERIC THIS MOVEMENT MAY BE EITHER BACKWARD OR FORWARD. BUT IF F1 IS LITERAL THEN BACKWARD MOVEMENT IS NOT PERMITTED.

IF FIELD F2 IS NOT NULL THEN TAPE A IS COPIED (FROM WHEREVER F1 LEFT IT) THROUGH RECORD NUMBER F2.

THIS CARD HAS NO TEXT FIELD, AND NO FOLLOWING FREE TEXT CARDS.

\*\*\*\*\*  
B-CARD. \$F1,F2,B  
\*\*\*\*\*

THE B-CARD DESIGNATES TAPE B AS THE ACTIVE INPUT TAPE. THIS DESIGNATION REMAINS IN EFFECT UNTIL THE NEXT A-CARD.

IF FIELD F1 IS NOT NULL THEN THE TAPE IS MOVED INTO POSITION TO READ RECORD NUMBER F1. IF F1 IS NUMERIC THIS MOVEMENT MAY BE EITHER BACKWARD OR FORWARD. BUT IF F1 IS LITERAL THEN BACKWARD MOVEMENT IS NOT PERMITTED.

IF FIELD F2 IS NOT NULL THEN TAPE B IS COPIED (FROM WHEREVER F1 LEFT IT) THROUGH RECORD NUMBER F2.

THIS CARD HAS NO TEXT FIELD, AND NO FOLLOWING FREE TEXT CARDS.

\*\*\*\*\*  
D-CARD. \$F1,F2,D  
\*\*\*\*\*

THIS CARD DELETES RECORDS F1 THROUGH F2. IF F2 IS NULL THEN THE SINGLE RECORD F1 IS DELETED. F1 SHOULD NOT BE NULL OR ASK FOR BACKWARD MOVEMENT OF THE INPUT TAPE.

F (continued)

7094 EDIT PROGRAM

\*\*\*\*\*  
E-CARD. \$F1,E  
\*\*\*\*\*

THIS END CARD SHOULD BE THE LAST CARD OF THE CHANGE DECK, AND SHOULD NOT OCCUR ELSEWHERE. THE ACTIVE INPUT TAPE IS COPIED THROUGH RECORD NUMBER F1 AND THE RUN IS TERMINATED. IF F1 IS NULL THEN NO RECORDS ARE COPIED.

IF THIS CARD IS OMITTED FROM THE DECK THEN A COPY OF IT (WITH F1 NULL) IS AUTOMATICALLY GENERATED AFTER THE LAST CHANGE CARD HAS BEEN TAKEN CARE OF.

\*\*\*\*\*  
F-CARD. \$F1,F2,F  
\*\*\*\*\*

THIS CARD SETS THE LEFT MARGIN FOR CHANGE CARDS TO F1, THE RIGHT MARGIN TO F2. CHARACTERS TO THE LEFT OF F1 AND TO THE RIGHT OF F2 ARE IGNORED. IF F1 IS ZERO (OR NULL) IT IS TAKEN AS 1. IF F2 IS ZERO (OR NULL) THE RIGHT MARGIN IS NOT CROPPED. BOTH F1 AND F2 MUST BE NUMERIC. THE MARGIN PARAMETERS ARE ASSUMED TO BE (0,0), TO USE THE FULL RECORD, UNTIL THE FIRST F-CARD IS MET. THEREAFTER, EACH F-CARD REMAINS IN FORCE UNTIL THE NEXT F-, T-, OR TX-CARD IS MET.

ELSEWHERE IN THIS MEMO SUCH PHRASES AS 'COLUMN ONE OF THE CHANGE CARD', 'THE LAST NONBLANK CHARACTER', ETC., APPLY TO WHAT IS LEFT AFTER THE MARGIN ADJUSTMENT HERE DESCRIBED.

\*\*\*\*\*  
I-CARD. \$F1,I,TEXT  
\*\*\*\*\*

THIS CARD INSERTS INDENTED PARAGRAPHS OF FREE TEXT AFTER RECORD NUMBER F1. IF F1 IS NULL THE INPUT TAPE IS NOT MOVED.

IF THE TEXT FIELD IS NOT NULL A NEW RECORD IS STARTED WITH THE FIRST CHARACTER OF THE TEXT IN COLUMN 6 OF THE TAPE RECORD.

THEN FREE TEXT CARDS ARE READ IN UNTIL THE NEXT CONTROL CARD IS MET. A FREE TEXT CARD STARTS A NEW RECORD (WITH ITS FIRST NON-BLANK CHARACTER PUT IN COLUMN 6 OF THE TAPE RECORD) IF ITS COLUMN 1 IS BLANK. IF COLUMN 1 OF THE CARD IS NOT BLANK, IT IS ADDED TO THE CURRENT OUTPUT RECORD, WITH STANDARD RIGHT-END TREATMENT.

\*\*\*\*\*  
J-CARD. \$F1,J  
\*\*\*\*\*

THIS CARD JOINS RECORD NUMBER F1 AND THE RECORD FOLLOWING IT INTO A SINGLE RECORD. THE TERMINAL DOLLAR SIGN OF RECORD F1 IS REPLACED BY A BLANK, WHICH IS IMMEDIATELY FOLLOWED BY THE CHARACTER IN COLUMN 6 OF THE NEXT RECORD.

A J-CARD, IF USED, MUST FOLLOW ALL THE R- AND P-CARDS APPLYING TO RECORD F1 AND PRECEDE ALL THOSE APPLYING TO RECORD F1+1.

F (continued)

94 EDIT PROGRAM

\*\*\*\*\*  
K-CARD. \$K,TEXT AUTO-KEY INSERTION  
\*\*\*\*\*

THIS CARD USES THE FIRST 28 CHARACTERS OF ITS TEXT AS A  
CORD DESIGNATOR (JUST AS THE I-CARD USES F1), AND AFTER THE  
CORD SO DESIGNATED INSERTS THIS NEW RECORD. THE FIRST CHARACTER  
THE TEXT FIELD BECOMES COLUMN 8 OF THE TAPE RECORD. FOLLOWING  
EE TEXT CARDS ARE THEN ADDED TO THE NEW RECORD. THEIR LEADING  
ANKS ARE ELIMINATED AND STANDARD RIGHT END TREATMENT IS USED.

\*\*\*\*\*  
L-CARD. \$F1,L,TEXT  
\*\*\*\*\*

THIS CARD INSERTS LINE-FOR-LINE FREE TEXT AFTER RECORD NUMBER  
. IF F1 IS NULL THE INPUT TAPE IS NOT MOVED.  
IF THE TEXT FIELD IS NOT NULL THEN A RECORD IS MADE WITH THE  
RST CHARACTER OF TEXT IN COLUMN 6.  
THEN FREE TEXT CARDS ARE READ IN UNTIL THE NEXT CONTROL CARD  
MET. EACH FREE TEXT CARD BECOMES A SINGLE RECORD WITH COLUMN 1  
THE CARD IN COLUMN 8 OF THE TAPE RECORD, AND STANDARD RIGHT-END  
EATMENT.

\*\*\*\*\*  
NA-CARD. \$=SYSXZN\$,NA  
\*\*\*\*\*

THIS CARD NAMES INPUT TAPE A AS SYSTEM TAPE 'SYSXZN', WHERE  
X = A OR B, SPECIFYING A SYMBOLIC CHANNEL.  
Z = R FOR A RESERVED TAPE,  
= U FOR A SCRATCH TAPE.  
N = 4-8 FOR SYMBOLIC UNIT.

THIS CARD DOES APPEAR, IT MUST PRECEDE ANY OTHER REFERENCE TO  
PE A. IF THIS CARD DOES NOT APPEAR, THEN TAPE A RECEIVES ITS  
ANDARD NAME (SYSAR4) AUTOMATICALLY.

\*\*\*\*\*  
NB-CARD. \$=SYSXZN\$,NH  
\*\*\*\*\*

THIS CARD NAMES INPUT TAPE B, JUST AS THE NA-CARD NAMES TAPE  
IF THIS CARD IS NOT USED, TAPE B RECEIVES ITS STANDARD NAME  
YSBR5).

F (continued)

094 EDIT PROGRAM

```
*****  
NO-CARD. $=SYSX7N1,NO  
*****
```

THIS CARD NAMES THE OUTPUT TAPE, JUST AS THE NA-CARD NAMES TAPE A. IF THIS CARD IS NOT USED, THE OUTPUT TAPE RECEIVES ITS STANDARD NAME (SYSBR6).

```
*****  
NT-CARD. $=SYSXZN$,NT  
*****
```

THIS CARD NAMES THE CHANGE TAPE (SEE T-CARD), JUST AS THE NA-CARD NAMES THE A-TAPE. IF THIS CARD IS NOT USED, THE CHANGE TAPE RECEIVES ITS STANDARD NAME (SYSAR6).

```
*****  
O-CARD. $F1,O,TEXT  
*****
```

THIS CARD INSERTS OVERHANGING PARAGRAPHS OF FREE TEXT AFTER RECORD NUMBER F1. IF F1 IS NULL THE INPUT TAPE IS NOT MOVED. IF THE TEXT FIELD IS NOT NULL THEN A NEW RECORD IS STARTED WITH THE FIRST CHARACTER OF TEXT IN COLUMN 6 OF THE TAPE RECORD. THEN FREE TEXT IS READ IN UNTIL THE NEXT CONTROL CARD IS MET. A FREE TEXT CARD STARTS A NEW RECORD (FIRST CARD CHARACTER IN COLUMN 8 OF TAPE RECORD) IF COLUMN 1 IS NOT BLANK. IF A FREE TEXT CARD HAS COLUMN 1 BLANK THEN ALL LEADING BLANKS ARE DELETED AND IT IS ADDED TO THE CURRENT OUTPUT RECORD, WITH STANDARD RIGHT-END TREATMENT.

```
*****  
P-CARD. $F1,F2,F3,P  
*****
```

THIS CARD STARTS A NEW RECORD AFTER CHARACTER NUMBER F2 OF RECORD NUMBER F1 AND (IF F3 IS NOT NULL) SETS THE INPUT LOCATION POINTER TO CHARACTER F3.

IF F2 IS NULL THE BREAK IS MADE AT THE PRESENT VALUE OF THE INPUT LOCATION POINTER.

IF F1 IS NULL THIS CARD APPLIES TO THE SAME RECORD AS THE PRECEDING CONTROL CARD.

IF EITHER F2 OR F3 IS LITERAL, THE INTERPRETATION IS SIMILAR TO THAT FOR THE R-CARD.

```
*****  
R-CARD. $F1,F2,F3,R,TEXT  
*****
```

THIS CARD INSERTS ITS TEXT FIELD (WITH STANDARD RIGHT-TREATMENT) AFTER CHARACTER NUMBER F2 OF RECORD NUMBER F1 AND (IF F3 IS NOT NULL) SETS THE INPUT LOCATION POINTER TO F3.

THE TEXT OF AN R-CARD MAY BE CONTINUED ON AS MANY SUBSEQUENT CARDS AS DESIRED. LEADING BLANKS ARE ELIMINATED AND STANDARD

F (continued)

194 EDIT PROGRAM

RIGHT-END TREATMENT IS USED.

IF F1 IS NULL, THIS CARD APPLIES TO THE SAME RECORD AS THE PRECEDING CONTROL CARD.

IF F2 IS A LITERAL THEN THE CHARACTER NUMBER USED IS THAT OF THE RIGHTMOST CHARACTER OF THE FIRST INSTANCE OF THE SPECIFIED STRING FOUND TO THE RIGHT OF THE PRESENT INPUT LOCATION POINTER.

IF F3 IS A LITERAL THEN THE CHARACTER NUMBER USED IS THAT OF THE LEFTMOST CHARACTER OF THE FIRST INSTANCE OF THE SPECIFIED STRING FOUND TO THE RIGHT OF CHARACTER F2.

IF EITHER F2 OR F3 IS LITERAL AND THE STRING IS NOT FOUND, THEN THE CHARACTER NUMBER USED IS THE END OF THE RECORD (EXCLUDING TERMINAL DOLLAR SIGN).

IF F2 IS GREATER THAN OR EQUAL TO THE NUMBER OF CHARACTERS IN THE RECORD, THEN IT IS SET TO THE CHARACTER JUST AHEAD OF THE TERMINAL DOLLAR SIGN.

\*\*\*\*\*  
S-CARD. \$F1,F2,S,TEXT  
\*\*\*\*\*

THIS CARD SPECIFIES THAT, STARTING WITH RECORD NUMBER F1, EACH OCCURRENCE OF THE STRING F2 IN AN OUTPUT RECORD IS TO BE REPLACED BY THE TEXT STRING (WITH STANDARD RIGHT END TREATMENT). THE TEXT MAY BE CONTINUED ON AS MANY FREE TEXT CARDS AS YOU PLEASE. LEADING BLANKS ARE ELIMINATED AND STANDARD RIGHT END TREATMENT IS USED. F2 MUST BE A NON-VACUOUS LITERAL.

EACH SUBSTITUTION SPECIFIED BY AN S-CARD REMAINS IN EFFECT UNTIL AN SX-CARD IS ENCOUNTERED.

IF MORE THAN ONE SUBSTITUTION IS IN EFFECT, THEN EACH IS MADE IN ORDER, IN THE ORDER RECEIVED, SO THAT SUBSTITUTIONS WITHIN PREVIOUS SUBSTITUTIONS ARE POSSIBLE. THIS CARD IS DIFFERENT FROM MOST OTHER CONTROL CARDS IN THAT IF ONLY ONE PARAMETER FIELD IS GIVEN IT IS ASSUMED TO BE F2 INSTEAD OF F1.

\*\*\*\*\*  
SO-CARD. \$F1,F2,SO,TEXT  
\*\*\*\*\*

THIS CARD ACTS THE SAME AS AN S-CARD, EXCEPT THAT THE INDICATED SUBSTITUTION IS DONE IN RECORD F1 ONLY, NOT IN THE FOLLOWING RECORDS. THE SO-CARD SUBSTITUTIONS ARE MADE BEFORE THE S-CARD SUBSTITUTIONS (IF ANY ARE IN EFFECT). THIS CARD IS DIFFERENT FROM MOST OTHER CONTROL CARDS IN THAT IF ONLY ONE PARAMETER FIELD IS GIVEN IT IS ASSUMED TO BE F2 INSTEAD OF F1.

\*\*\*\*\*  
SX-CARD. \$F1,SX  
\*\*\*\*\*

THIS CARD CANCELS ALL ACCUMULATED SUBSTITUTIONS SPECIFIED BY PRECEDING S-CARDS, EFFECTIVE WITH RECORD NUMBER F1. THAT IS, THE SUBSTITUTIONS WILL NOT BE MADE IN F1 AND FOLLOWING RECORDS.



F (continued)

7094 EDIT PROGRAM

\*\*\*\*\*  
T-CARD. \$F1,F2,T  
\*\*\*\*\*

THIS SETS A SWITCH TO READ THE FOLLOWING CHANGE RECORDS FROM TAPE INSTEAD OF CARDS, UNTIL A TX-CARD IS MET OR THE CHANGE TAPE. THE FIELDS F1 AND F2 SET THE MARGINS, JUST AS FOR AN F-CARD. EVERY RECORD ON THE CHANGE TAPE MUST HAVE ITS RIGHT END GUARDED BY A DOLLAR SIGN.

\*\*\*\*\*  
TX-CARD. \$F1,F2,TX  
\*\*\*\*\*

THIS RECORD RESETS THE SWITCH (SET BY A T-CARD) TO RESUME READING CHANGE RECORDS FROM CARDS INSTEAD OF TAPE. THE FIELDS F1 AND F2 SET MARGINS JUST AS IN THE F-CARD.

\*\*\*\*\*  
U-CARD. \$F1,U,TEXT  
\*\*\*\*\*

THIS CARD SPECIFIES THAT EACH OCCURRENCE OF THE STRING (L IN A CHANGE CARD (OTHER THAN U-CARDS) IS TO BE REPLACED BY THE TEXT STRING (WITH STANDARD RIGHT END TREATMENT). THE TEXT MAY BE CONTINUED ON AS MANY FREE TEXT CARDS AS YOU PLEASE. LEADING BLANKS ARE ELIMINATED AND STANDARD RIGHT END TREATMENT IS USED. F1 MUST BE A NON-VACUOUS LITERAL. THESE SUBSTITUTIONS REMAIN IN EFFECT UNTIL A UX-CARD IS ENCOUNTERED.

IF MORE THAN ONE SUBSTITUTION IS IN EFFECT, THEN EACH IS MADE AB INITIO, IN THE ORDER RECEIVED, SO THAT SUBSTITUTIONS WITHIN (PREVIOUS) SUBSTITUTIONS ARE POSSIBLE.

\*\*\*\*\*  
UX-CARD. \$UX  
\*\*\*\*\*

THIS CARD CANCELS THE EFFECT OF ALL PRECEDING U-CARDS.

\*\*\*\*\*  
V-CARD. \$V  
\*\*\*\*\*

THIS CARD PUTS THE PROGRAM IN THE SORTING MODE, SO TO REMAIN UNTIL A VX-CARD IS MET. ALL THE CARDS BETWEEN THE V-CARD AND THE NEXT FOLLOWING VX-CARD ARE SAID TO BE WITHIN THE SCOPE OF A V-CARD. ALL CARDS WITHIN THE SCOPE OF A V-CARD MUST BE EITHER CONTROL CARDS WHOSE FIRST FIELD IS A RECORD NUMBER (INCLUDING K-CARDS) OR FREE TEXT CARDS GOVERNED BY SUCH A CONTROL CARD PRECEDING THEM WITHIN THE SCOPE OF THE SAME V-CARD. IF A V-CARD OCCURS, THEN A VX-CARD MUST OCCUR BETWEEN IT AND THE E-CARD.

EACH CARD WITHIN THE SCOPE WILL HAVE A 24-CHARACTER SECURITY KEY ASSIGNED TO IT IN THE FOLLOWING WAY.

IF THE RECORD NUMBER IS NUMERIC AND NON-NULL THEN THE KEY

F (continued)

7094 EDIT PROGRAM

CONSISTS OF ITS FIVE DIGITS (WITH LEADING ZEROS ADDED) PADDED ON THE RIGHT WITH BLANKS.

IF THE RECORD NUMBER IS A LITERAL AND NON-VACUOUS THEN THE KEY CONSISTS OF ITS (FIRST 24) CHARACTERS, PADDED ON THE RIGHT WITH BLANKS.

IF THIS IS A K-CARD THEN THE KEY IS THE FIRST 24 CHARACTERS OF ITS TEXT FIELD.

IF THE RECORD NUMBER IS NULL OR VACUOUS, OR IF THIS IS A FREE TEXT CARD, THEN THE KEY IS THE SAME AS THAT OF THE PRECEDING CARD. INITIALLY, THE KEY CONSISTS OF 24 BLANKS UNTIL THE FIRST NON-NULL RECORD NUMBER IS MET. THE LAST FOUR CHARACTERS OF THE KEY ARE A FOUR-DIGIT SEQUENCE NUMBER, TO ENSURE THAT CARDS WITH THE SAME 24-CHARACTER KEYS KEEP THEIR ORIGINAL RELATIVE ORDER.

THE CARDS ARE NOW SORTED BY THEIR KEYS, AND THEN USED IN THE USUAL WAY. BECAUSE OF MEMORY LIMITATIONS IT IS NOT POSSIBLE TO REMEMBER MORE THAN 300 CARDS AT A TIME. HENCE, IF A CARD IN THE ORIGINAL SCOPE IS PRECEDED BY MORE THAN 300 CARDS WHICH SHOULD IN FACT FOLLOW IT, THEN IT WILL NOT BE PUT IN PROPER SEQUENCE. IF YOU ARE MAKING A LARGE NUMBER OF CHANGES IN THIS MODE, THEREFORE, THEY SHOULD BE MADE IN SECTIONS SO THAT ALL THE CARDS OF ONE SECTION PRECEDE ALL THE CARDS OF THE NEXT SECTION AND NO SECTION CONTAINS MORE THAN 300 CARDS. ALL THE SECTIONS MAY THEN FALL IN THE SAME SCOPE.

ONLY THE FIRST 80 CHARACTERS OF THE CHANGE CARD, AFTER CROPPING MARGINS (SEE F-CARD) BUT BEFORE SUBSTITUTING (SEE U-CARD) ARE KEPT DURING THE SORT. IF CARD INPUT IS USED, OF COURSE, THIS IS NO RESTRICTION. BUT IF TAPE INPUT (SEE T-CARD) IS USED, YOU MUST MAKE SURE YOUR CHANGE RECORDS STAY WITHIN THIS LIMIT IF THEY ARE WITHIN THE SCOPE OF A V-CARD (OTHERWISE THE NOMINAL LIMIT OF 999 CHARACTERS APPLIES).

SINCE DIGITS COLLATE AFTER ALL OTHER CHARACTERS, ALL CARDS GOVERNED BY NON-NULL NUMERIC FIELDS WILL SORT AFTER ALL CARDS GOVERNED BY LITERAL FIELDS NOT STARTING WITH A DECIMAL DIGIT. HENCE YOU MUST KEEP YOUR WITS ABOUT YOU IF YOU INCLUDE NUMERIC AND LITERAL F1-FIELDS WITHIN THE SAME SCOPE.

EVEN WITH ALL THE LIMITATIONS JUST DESCRIBED, THIS FEATURE CAN BE EXTREMELY USEFUL UNDER SOME CIRCUMSTANCES, AND IS WORTH BECOMING FAMILIAR WITH.

\*\*\*\*\*  
VX-CARD. \$VX  
\*\*\*\*\*

THIS CARD TERMINATES THE SCOPE OF A PRECEDING V-CARD. IF, BY MISTAKE, A VX-CARD IS ENCOUNTERED WHEN A V-CARD IS NOT IN EFFECT THEN THE VX-CARD IS IGNORED.

F (continued)

7094 EDIT PROGRAM

```
*****
Y-CARD. SFI,...,Y,TEXT
*****
```

IN THE STANDARD EDIT PROGRAM THIS CARD CONVERTS THE PARAMETER FIELDS (UP TO 8 OF THEM) AND TRANSFERS CONTROL TO SUBROUTINE 'DY' WITH THE 'CARD' LOCATION POINTER SET AT THE 'Y'. ROUTINE 'DY' NORMALLY PRINTS AN ALARM AND TAKES THE NEXT CARD. IF YOU WANT TO DO SOMETHING SPECIAL, HOWEVER, YOU MAY WRITE YOUR OWN 'DY' ROUTINE AND THUS OBTAIN AN AD HOC VERSION OF THE PROGRAM BY RECOMPILATION.

```
*****
JOB DECK SETUP.
*****
```

IN ADDITION TO THE CHANGE DECK DESCRIBED ABOVE, IT IS NECESSARY TO INCLUDE SYSTEM CONTROL CARDS TO ENSURE THAT THE MACHINE COMPORTS ITSELF PROPERLY. THE JOB DECK THEN HAS THE FOLLOWING FORM-

1. JOB CARD.
2. TAPE ASSIGNMENT CARDS.
3. MANIPULATOR PROGRAM.
4. EDIT PROGRAM.
5. CHANGE DECK.

THESE MAY BE FOLLOWED BY SUBDECKS TO CARRY OUT ANY LATER ACTIONS THAT ARE DESIRED, SUCH AS, FOR EXAMPLE, THE PRINT PROGRAM AND ITS CONTROL CARDS, ETC.

1. THE JOB CARD HAS 7-8-9 PUNCHES IN COLUMN 1, 'JOB' IN COLUMN 8, AND A FREE FIELD STARTING IN COLUMN 16 CONSISTING OF SIX ITEMS SEPARATED BY COMMAS. NAMELY, THE JOB NUMBER, THE LETTER 'P', YOUR NAME, THE ESTIMATED TIME IN HUNDRETHS OF HOURS, 999999, 999999. FOR EXAMPLE-

JOB 233,P,SMITH,20,999999,999999

NO ITEM CAN BE LONGER THAN SIX CHARACTERS AND NO SPACES CAN BE USED.

2. TAPE ASSIGNMENT CARDS FOR EACH TAPE TO BE USED. EACH SUCH CARD HAS 7-8-9 PUNCHES IN COLUMN 1, 'ASSIGN' IN COLUMN 8, AND 'CK=SYSXZN' IN COLUMN 16. AFTER LEAVING AT LEAST ONE SPACE YOU MAY THEN WRITE ANY COMMENT ABOUT THE TAPE THAT YOU WANT THE OPERATOR TO READ. IN THE ASSIGNMENT CODE 'CK=SYSXZN' THE 'C' IS A CHANNEL LETTER, THE 'K' A TAPE NUMBER, 'X' IS EITHER A OR B, 'Z' IS EITHER R OR U, AND 'N' IS A SYMBOLIC TAPE NUMBER. YOU SHOULD NORMALLY USE AS MANY OF THE FOLLOWING AS YOU NEED-

ASSIGN A4=SYSAR4 EDIT INPUT TAPE A (ALWAYS NEEDED FOR UPDATE)

ASSIGN A8=SYSBR5 EDIT INPUT TAPE B (NEEDED IF 4-CARD IS USED)

ASSIGN A7=SYSAR6 CHANGE TAPE (NEEDED IF T-CARD IS USED)

ASSIGN A5=SYSBR6 OUTPUT TAPE (ALWAYS NEEDED)

IF OTHER ASSIGNMENTS ARE NECESSARY (IE. IF NA-, NB-, NC-, OR NT-CARDS ARE USED), DISCUSS THE QUESTION WITH A PROGRAMMER.

3. THE MANIPULATOR PROGRAM IS CALLED IN FROM THE LIBRARY BY A CARD WITH 7-8 PUNCHES IN COLUMN 1, 'LHRL' IN COLUMN 8, AND 'IN-PACK' IN COLUMN 16. NAMELY-

F (continued)

7094 EDIT PROGRAM

11

LBRL INPACK

4. THE EDIT PROGRAM IS SIMILARLY CALLED, NAMELY-

LBRL EDIT

5. THE CHANGE DECK IS AS DESCRIBED ABOVE IN DETAIL.

**APPENDIX G**  
**PRINT PROGRAM**

TO- DISTRIBUTION  
 FROM- R.P. RICH  
 SUBJECT- 7094 PRINT PROGRAM

TABLE OF CONTENTS

THE PRINT PROGRAM.....	1
PARAMETER CARD.....	1
K1- FIRST CHARACTER PRINTED.....	2
K2- LEFT MARGIN, FIRST LINE.....	2
K3- LEFT MARGIN, OTHER LINES.....	2
K4- RIGHT MARGIN.....	2
K5- BLANKS BETWEEN RECORDS.....	3
K6- BLANKS BETWEEN LINES.....	3
K7- RIGHT MARGIN ADJUSTMENT.....	3
K8- LINES PER PAGE.....	3
K9- FILE CONTROL.....	4
K10- LAST CHARACTER PRINTED.....	4
K11- JUSTIFY RIGHT MARGIN.....	4
K12- NEW LINE CHARACTER.....	5
K14- SELECTION MODE.....	5
K15- LINE NUMBERING.....	5
K16- LEFT MARGIN FOR HEADINGS.....	6
K17- AUXILIARY LEFT MARGIN.....	6
K18- SELECTION CONTROL.....	6
K19- PUNCH CONTROL.....	7
FORMAT CONTROL CHARACTERS.....	6
HEADER RECORD.....	7
NEW PAGE NUMBER.....	7
FORMAT CHANGE RECORD.....	7
CONTENTS RECORD.....	7
CONTINUATION RECORD.....	7
ELIMINATION OF RECORD.....	8
SELECTION CONTROL.....	8
NEW PAGE WARNING.....	8
USE SECOND LINE MARGIN.....	8
NON-PRINTING CHARACTER.....	8
HYPHENATION RULES.....	1
TAPE DESIGNATION.....	1
USAGE OF THE SYSTEM.....	1

G (continued)

THE 7094 PRINT PROGRAM.

\*\*\*\*\*  
THE PRINT PROGRAM  
\*\*\*\*\*

THE PRINT PROGRAM IS DESIGNED TO PRINT THE CONTENTS OF ONE OR MORE MAGNETIC TAPE FILES IN STANDARD INFORMATION PACKAGE FORMAT. EACH SUCH FILE CONSISTS OF RECORDS UP TO 10,000 CHARACTERS LONG, THE LAST RECORD BEING FOLLOWED BY A FILE MARK. EACH RECORD CONSISTS OF A 5-DIGIT RECORD NUMBER, FOLLOWED BY TWO FORMAT CONTROL CHARACTERS (WHOSE USE IS DESCRIBED IN DETAIL BELOW), FOLLOWED BY THE TEXT OF THE RECORD, FOLLOWED BY A TERMINAL DOLLAR SIGN. THIS IS, FOR EXAMPLE, THE FORMAT PROVIDED BY THE 'EDIT' AND 'SEARCH' PROGRAMS OF THE INFORMATION PACKAGE.

THE FORMAT OF THE PRINTED OUTPUT, RECORDS SELECTED FOR PRINTING, ETC., ARE SPECIFIED JOINTLY BY FORMAT PARAMETERS AND THE FORMAT CONTROL CHARACTERS IN POSITIONS 6-7 OF EACH RECORD, IN THE FASHION DESCRIBED IN DETAIL BELOW.

THE PRESENT MEMO IS AN EXAMPLE OF THE USE OF THE PRINT PROGRAM.

\*\*\*\*\*  
PARAMETER CARD.  
\*\*\*\*\*

THE PROGRAM DECK MUST BE FOLLOWED BY A PARAMETER CARD FOR EACH FILE ON THE TAPE UP TO AND INCLUDING THE LAST FILE WHICH IS TO BE PRINTED. IF LISTINGS OF THE SAME FILE IN MORE THAN ONE FORMAT ARE DESIRED, THEN A PARAMETER CARD MUST BE INCLUDED FOR EACH FORMAT. ONLY PARAMETERS WHICH ARE TO BE CHANGED FROM THEIR VALUES FOR THE PRECEDING FILE (OR FROM THEIR INITIAL VALUES IF THIS IS THE FIRST FILE) NEED TO BE PUT ON THE PARAMETER CARD. THUS, IN PARTICULAR, IF NO CHANGES ARE REQUIRED, THE PARAMETER CARD WILL BE BLANK, BUT MUST STILL BE INCLUDED.

EACH PARAMETER REQUIRES A FIELD OF FIVE CARD COLUMNS. THE FIRST TWO OF THESE COLUMNS CONTAIN THE NUMBER OF THE PARAMETER, AND THE NEXT THREE CONTAIN ITS VALUE. BOTH SUBFIELDS ARE RIGHT ADJUSTED AND LEADING ZEROS MUST BE PUNCHED. PUNCHING STARTS IN COLUMN ONE AND CONTINUES UNTIL ALL THE NECESSARY PARAMETERS HAVE BEEN PUNCHED. THE REST OF THE CARD IS LEFT BLANK. THE PARAMETERS MAY BE PUNCHED IN ANY ORDER.

FOR EXAMPLE, TO SET PARAMETER NUMBER 4 TO 50, PARAMETER NUMBER 2 TO 8, AND PARAMETER NUMBER 3 TO 15, THE FIRST 15 COLUMNS WOULD BE PUNCHED

040500200803015

THE SEVERAL PARAMETERS ARE DESCRIBED IN DETAIL BELOW. THE INITIAL VALUE OF EACH IS GIVEN IN PARENTHESES IMMEDIATELY FOLLOWING THE PARAMETER NUMBER.

THE STANDARD VALUES OF THE PARAMETERS DEFINE A SINGLE-SPACED FORMAT WITH PRECISELY 100 CHARACTERS PER LINE. THE LINES OF THE RECORD (EXCEPT FOR LINE NUMBER ZERO) ARE NUMBERED IN THE LEFT

G (continued)

THE 7094 PRINT PROGRAM.  
PARAMETER CARDS.

MARGIN. THIS STANDARD-FORMAT LISTING WILL BE OBTAINED BY PUTTING A BLANK PARAMETER CARD AHEAD OF THE PARAMETER CARDS REQUIRED FOR ANY OTHER LISTINGS THAT MAY BE DESIRED. IT MAY BE USED TO OBTAIN CHARACTER COUNTS FOR FURTHER CHANGES USING THE 'EDIT' PROGRAM DESCRIBED IN BCC-345.

\*\*\*\*\*  
PARAMETER 1 (001) FIRST CHARACTER PRINTED.  
\*\*\*\*\*

THIS IS THE NUMBER OF THE FIRST CHARACTER OF THE RECORD WHICH IS TO BE PRINTED. IF IT IS LEFT EQUAL TO 1 THE FIRST CHARACTER WILL BE PRINTED. IF IT IS SET EQUAL TO N THEN THE N-TH CHARACTER OF THE RECORD WILL BE THE FIRST ONE PRINTED, THE FIRST N-1 CHARACTERS BEING IGNORED.

SINCE THE TEXT FOR EACH RECORD BEGINS IN CHARACTER POSITION 8, THIS PARAMETER SHOULD USUALLY BE SET TO 008 FOR THE FINAL LISTING.

\*\*\*\*\*  
PARAMETER 2 (011) LEFT MARGIN, FIRST LINE.  
\*\*\*\*\*

THE PRINTER LINE HAS 131 CHARACTER POSITIONS. THIS PARAMETER SPECIFIES THE CHARACTER POSITION IN WHICH THE FIRST PRINTED CHARACTER OF EACH RECORD WILL APPEAR, AND HENCE SETS THE LEFT MARGIN FOR THE FIRST LINE OF EACH RECORD.

\*\*\*\*\*  
PARAMETER 3 (011) LEFT MARGIN, OTHER LINES.  
\*\*\*\*\*

THIS PARAMETER SETS THE LEFT MARGIN FOR THE SECOND AND ALL FOLLOWING LINES OF THE RECORD IN THE SAME WAY THAT PARAMETER 2 DOES FOR THE FIRST LINE.

\*\*\*\*\*  
PARAMETER 4 (110) RIGHT MARGIN.  
\*\*\*\*\*

THIS PARAMETER SETS THE RIGHT MARGIN FOR ALL LINES OF THE LISTING, IN THE SENSE THAT NOTHING WILL BE PRINTED TO THE RIGHT OF THE CHARACTER POSITION INDICATED. BUT SOME LINES MAY END SHORT OF THIS POINT BECAUSE OF WORD-BREAKS (SEE PARAMETER 7). THIS PARAMETER MUST BE LESS THAN 132, AND SHOULD EXCEED BOTH PARAMETERS 2 AND 3 BY AT LEAST TWENTY TO ENSURE REASONABLE RESULTS.



G (continued)

THE 7094 PRINT PROGRAM.  
PARAMETER CARDS.  
PARAMETER 5.

\*\*\*\*\*  
PARAMETER 5 (001) BLANKS BETWEEN RECORDS.  
\*\*\*\*\*

THIS PARAMETER SPECIFIES THE NUMBER OF BLANK LINES TO BE INSERTED BETWEEN THE LAST LINE OF ONE RECORD AND THE FIRST LINE OF THE NEXT. THE VALUE 0 CORRESPONDS TO SINGLE-SPACING, THE VALUE 1 LEAVES ONE BLANK LINE, ETC. IF THERE IS NOT ROOM ON THE PRESENT PAGE FOR THE NUMBER OF BLANK LINES SPECIFIED THEN A NEW PAGE WILL BE STARTED, BUT THE UNUSED BLANK LINES WILL NOT BE CARRIED OVER TO THE TOP OF THE NEW PAGE. IN ADDITION TO ITS OBVIOUS APPLICATION, THIS FEATURE PERMITS PRINTING OF ONE RECORD PER PAGE, IF DESIRED, BY SETTING THIS PARAMETER GREATER THAN PARAMETER 8.

\*\*\*\*\*  
PARAMETER 6 (000) BLANKS BETWEEN LINES.  
\*\*\*\*\*

THIS PARAMETER SPECIFIES THE NUMBER OF BLANK LINES TO BE LEFT BETWEEN SUCCESSIVE LINES OF THE SAME RECORD. THE VALUE 0 CORRESPONDS TO SINGLE SPACING, THE VALUE 1 LEAVES ONE BLANK LINE BETWEEN DATA LINES, ETC. IF THERE IS NOT ROOM ON THE PRESENT PAGE FOR THE NUMBER OF BLANK LINES SPECIFIED THEN A NEW PAGE WILL BE STARTED, BUT THE UNUSED BLANK LINES WILL NOT BE CARRIED OVER TO THE TOP OF THE NEW PAGE.

\*\*\*\*\*  
PARAMETER 7 (000) RIGHT MARGIN ADJUSTMENT.  
\*\*\*\*\*

IF THIS PARAMETER IS 0 THEN EACH LINE WILL END PRECISELY AT THE SPECIFIED RIGHT MARGIN POSITION, AS SET BY PARAMETER 4, AND THE FORMAT CONTROL CHARACTERS (POSITIONS 6 AND 7 OF THE RECORD) ARE IGNORED. IF THIS PARAMETER IS 1, THEN THE FORMAT CONTROL CHARACTERS WILL BE OBEYED AND THE LINE WILL BE BROKEN AT A WORD OR SYLLABLE DIVISION IF POSSIBLE. THE HYPHENATION RULES ARE GIVEN BELOW.

IF THIS PARAMETER IS 2, THEN THE FORMAT CONTROL CHARACTERS IN POSITIONS 6 AND 7 OF THE RECORD WILL BE OBEYED, BUT THE LINE WILL BE BROKEN PRECISELY AT THE SPECIFIED RIGHT MARGIN WITHOUT REGARD TO WORD DIVISIONS.

\*\*\*\*\*  
PARAMETER 8 (057) LINES PER PAGE.  
\*\*\*\*\*

THIS PARAMETER SETS THE MAXIMUM NUMBER OF PRINTER LINES PER PAGE, INCLUDING THE HEADER LINES AND ONE BLANK LINE FOLLOWING THEM. IF THE VALUE OF THIS PARAMETER IS GREATER THAN 57 THEN THE PAGE BREAKS MAY NOT MATCH THE TEARING LINES OF THE PRINTER PAPER.

G (continued)

THE 7094 PRINT PROGRAM.  
PARAMETER CARDS.  
PARAMETER 8.

4

THE ACTUAL NUMBER OF LINES PRINTED VARIES FROM PAGE TO PAGE,  
DEPENDING ON HOW THE RECORDS FALL.

\*\*\*\*\*  
PARAMETER 9 (000) FILE CONTROL.  
\*\*\*\*\*

IF THIS PARAMETER IS 0 THEN NO FILES FOLLOWING THIS ONE WILL  
BE PRINTED. AT THE END OF THIS FILE THE TAPE IS REWOUND AND A NEW  
PARAMETER CARD IS READ IN AND THE FIRST FILE ON THE TAPE WILL BE  
TREATED ACCORDING TO THE NEW SET OF PARAMETERS. IF THIS PARAMETER  
IS 1, THE PARAMETER CARD FOR THE NEXT FILE WILL BE READ IN AND  
EXECUTED WHEN THIS CURRENT FILE IS FINISHED. IF THIS PARAMETER IS  
2 THE CURRENT FILE WILL BE SKIPPED, AND THE PARAMETER CARD FOR THE  
NEXT FILE WILL BE READ IN AND EXECUTED.

\*\*\*\*\*  
PARAMETER 10 (001) LAST CHARACTER PRINTED.  
\*\*\*\*\*

THIS IS THE NUMBER, COUNTING FROM THE END OF THE RECORD, OF  
THE LAST CHARACTER TO BE PRINTED. IF THE VALUE OF THIS PARAMETER  
IS 1 THEN THE LAST CHARACTER OF THE RECORD (ALWAYS A DOLLAR SIGN)  
WILL BE PRINTED. IF IT IS TWO THEN THE NEXT TO LAST CHARACTER  
WILL BE PRINTED BUT THE LAST CHARACTER WILL BE IGNORED, AND SO ON.  
SINCE THE TERMINAL DOLLAR SIGN IS NOT WANTED ON MOST FINAL  
LISTINGS, THIS PARAMETER WILL USUALLY BE SET TO 002 FOR SUCH  
LISTINGS.

\*\*\*\*\*  
PARAMETER 11 (000) JUSTIFY RIGHT MARGIN.  
\*\*\*\*\*

IF PARAMETER 7 IS NOT 1 THEN THIS PARAMETER IS IGNORED.  
IF PARAMETER 7 IS 1 THEN LINES ARE BROKEN ACCORDING TO THE  
HYPHENATION RULES SO AS NOT TO EXCEED THE RIGHT MARGIN SET BY  
PARAMETER 4. IF PARAMETER 11 IS 0 THE RIGHT MARGIN WILL THEN BE  
UNEVEN. IF PARAMETER 11 IS 1, HOWEVER, ADDITIONAL SPACES WILL BE  
INSERTED BETWEEN THE WORDS OF THE LINE TO MAKE THE RIGHT MARGIN  
EVEN.

\*\*\*\*\*  
PARAMETER 12 (000) NEW LINE CHARACTER.  
\*\*\*\*\*

THIS PARAMETER HAS THE FORM OYX, AND PERMITS ANY CHARACTER X  
(OTHER THAN ZERO) TO BE CHOSEN AS THE SIGNAL FOR STARTING A NEW  
LINE, AND ANY CHARACTER Y (OTHER THAN ZERO) AS THE SIGNAL TO PRINT  
NO MORE OF THIS RECORD. IF PARAMETER 7 IS ZERO THIS PARAMETER IS  
IGNORED. IF PARAMETER 7 IS NOT ZERO THEN THE FOLLOWING ACTIONS  
TAKE PLACE FOR WHICHEVER OF X, Y ARE NOT '0'.

THE 7094 PRINT PROGRAM.  
PARAMETER CARDS.  
PARAMETER 12.

AS EACH LINE IN TURN IS SELECTED FOR PRINTING, IT IS SCANNED FOR THE FIRST OCCURRENCE OF THE CHARACTER X. IF THIS CHARACTER DOES NOT OCCUR, THE LINE IS PRINTED AS DETERMINED BY THE OTHER PARAMETERS. BUT IF THE CHARACTER X DOES OCCUR WITHIN THE LINE, THEN THE X IS REPLACED BY A BLANK AND THE LINE IS TERMINATED AT THAT POINT. THE FOLLOWING LINE WILL START WITH THE NEXT NON-BLANK CHARACTER.

THE SPECIAL CHARACTER X MAY OCCUR SEVERAL TIMES WITHIN THE SAME RECORD IF DESIRED, AND EACH OCCURRENCE WILL START A NEW LINE.

IF THE NEW LINE CHARACTER X IS IMMEDIATELY FOLLOWED BY A COMMA, THEN THE COMMA AS WELL AS THE NEW LINE CHARACTER WILL BE ERASED, AND THE LEFT MARGIN FOR THE NEW LINE WILL BE SET BY PARAMETER 17 INSTEAD OF BY PARAMETER 3.

IF Y IS NOT 0, THE THE RECORD IS PRINTED ONLY UP TO (BUT NOT INCLUDING) THE LEFTMOST INSTANCE OF THE CHARACTER Y MET IN THE SCAN DESCRIBED ABOVE.

THIS FEATURE MAY ONLY BE USED WITH NORMAL RECORDS, NOT WITH HEADERS, FORMAT RECORDS, TABLE OF CONTENTS RECORDS, ETC.

\*\*\*\*\*  
PARAMETER 14 (000) SELECTION MODE.  
\*\*\*\*\*

IF THIS PARAMETER IS ZERO THEN THE WHOLE FILE WILL BE LISTED. IF THIS PARAMETER IS 1 THEN ONLY SELECTED RECORDS WILL BE LISTED, AS SPECIFIED BY SELECTION CARDS IMMEDIATELY FOLLOWING THE PARAMETER CARD.

EACH SET OF CONSECUTIVE RECORDS TO BE LISTED REQUIRES A CARD GIVING IN COLUMNS 1-5 THE NUMBER OF THE FIRST RECORD OF THE SEQUENCE AND IN COLUMNS 6-10 THE NUMBER OF THE LAST RECORD OF THE SEQUENCE. THUS TO PRINT RECORDS THREE THROUGH NINE INCLUSIVE WOULD REQUIRE A SELECTION CARD WITH COLUMNS 1-10 PUNCHED AS FOLLOWS-

0000300009

IF THE SEQUENCE CONSISTS OF ONLY ONE RECORD THEN ONLY COLUMNS 1-5 NEED TO BE PUNCHED, AND COLUMNS 6-10 MAY BE LEFT BLANK.

AS MANY SUCH SEQUENCES AS DESIRED MAY BE SELECTED, AND THEY MAY BE IN ANY ORDER. THE SEQUENCES WILL BE LISTED ONE AFTER THE OTHER IN THE SAME ORDER AS THEIR SELECTION CARDS, REGARDLESS OF THEIR ORDER ON THE INPUT TAPE.

THE SET OF SELECTION CARDS MUST BE FOLLOWED BY A CARD PUNCHED 99999 IN COLUMNS 1-5 TO TERMINATE THE LISTING OF THE CURRENT FILE.

\*\*\*\*\*  
PARAMETER 15 (009) CHARACTER POSITION OF LINE NUMBER.  
\*\*\*\*\*

THIS PARAMETER SPECIFIES THE CHARACTER POSITION IN WHICH THE LEAST SIGNIFICANT DIGIT OF THE LINE NUMBER IS TO BE PRINTED. IF THIS PARAMETER IS SET TO ZERO, NO LINE NUMBER WILL BE PRINTED. THE SEQUENCE OF LINE NUMBERS IS THE SAME AS THAT USED BY THE EDIT PROGRAM, NAMELY 0,1,...

G (continued)

THE 7094 PRINT PROGRAM.  
PARAMETER CARDS.  
PARAMETER 16.

\*\*\*\*\*  
PARAMETER 16 (011) LEFT MARGIN FOR HEADINGS.  
\*\*\*\*\*

THIS PARAMETER SPECIFIES THE LEFT MARGIN FOR SEVERAL KINDS OF LINES SPECIFIED BY FORMAT CONTROL CHARACTERS IN POSITION SIX OF THE FILE RECORD, SUCH AS PAGE HEADINGS, LINES STORED FOR TABLE OF CONTENTS, ETC.

\*\*\*\*\*  
PARAMETER 17 (016) AUXILIARY LEFT MARGIN.  
\*\*\*\*\*

IF A NEW-LINE CHARACTER (SEE PARAMETER 12) OCCURS AND IS IMMEDIATELY FOLLOWED BY A COMMA, THEN THIS PARAMETER, RATHER THAN PARAMETER 3, WILL BE USED TO SET THE LEFT MARGIN OF THE NEXT LINE.

\*\*\*\*\*  
PARAMETER 18 (000) SELECTION CONTROL.  
\*\*\*\*\*

THIS PARAMETER SPECIFIES THE LEVEL OF SELECTION FOR RECORDS WITH AN S IN COLUMN 6 AND A DIGIT IN COLUMN 7, AS EXPLAINED UNDER FORMAT CONTROL CHARACTERS.

\*\*\*\*\*  
PARAMETER 19(000) PUNCH CONTROL.  
\*\*\*\*\*

THIS PARAMETER GOVERNS THE PUNCHING OF LINES OF TEXT ON CARDS. IF IT IS ZERO THEN THE LINES ARE PRINTED AND NOT PUNCHED. IF IT IS 1 THEN THE LINES ARE PUNCHED AND NOT PRINTED. IF IT IS 2 THEN THE LINES ARE BOTH PRINTED AND PUNCHED. THIS APPLIES TO TEXT LINES ONLY - SUCH SPECIAL RECORDS AS PAGE HEADINGS, TABLE OF CONTENTS ENTRIES, ETC., ARE ALWAYS PRINTED AND NEVER PUNCHED, REGARDLESS OF THE SETTING OF THIS PARAMETER.

REMEMBER THAT A PUNCHED CARD ONLY HAS 80 COLUMNS, SO THAT IF PARAMETER 4 IS GREATER THAN 80 THEN INFORMATION WILL BE LOST FROM THE RIGHT END OF THE LINE.

\*\*\*\*\*  
FORMAT CONTROL CHARACTER.  
\*\*\*\*\*

THE FIRST FIVE CHARACTERS OF EACH RECORD ARE THE RECORD NUMBER. CHARACTERS 6 AND 7 ARE NORMALLY LEFT BLANK.

CHARACTERS 6 AND 7 MAY BE USED FOR FORMAT CONTROL IN ANY OF THE FOLLOWING WAYS, PROVIDING PARAMETER 7 IS A ONE. IF PARAMETER 7 IS ZERO THEN EACH RECORD IS PRINTED AS IS AND THE FORMAT CONTROL IS IGNORED.

THE 7094 PRINT PROGRAM.  
 FORMAT CONTROL CHARACTERS.  
 HEADER RECORD.

7

\*\*\*\*\*  
 HEADER RECORD.  
 \*\*\*\*\*

THE PRINT PROGRAM WILL STORE UP TO 10 LINES OF PAGE HEADING INFORMATION, TO BE PRINTED AT THE TOP OF EACH PAGE. THESE LINES HAVE INDEXES (FOR PURPOSES OF THIS DISCUSSION) 0, 1, ..., 9 FROM TOP TO BOTTOM.

EACH HEADER LINE MAY BE STORED FOR LATER USE BY MEANS OF A RECORD WITH 'H' IN COLUMN 6 AND THE LINE INDEX I (=0,1,...,9) IN COLUMN 7. CHARACTERS 8-END OF THIS RECORD ARE STORED AS THE I-TH HEADING LINE AND ALL HEADING LINES WITH LARGER INDEXES ARE ERASED. A BLANK IN COLUMN 7 IS INTERPRETED AS ZERO.

AN ASTERISK IN COLUMN 6 STORES A NEW HEADER LINE AND ERASES THE FOLLOWING LINES JUST AS AN 'H' IN COLUMN 6 DOES. BUT IN ADDITION, THE ASTERISK FORCES A NEW PAGE FORTHWITH ALSO.

EACH HEADER LINE IS PRINTED AS IT STANDS, WITH THE CHARACTER IN COLUMN 8 OF THE HEADER RECORD APPEARING ON THE PRINTED PAGE IN THE POSITION SPECIFIED BY PARAMETER 16. A PRINTER LINE CAN CONTAIN AT MOST 131 CHARACTERS, SO IF THE HEADER RECORD IS TOO LONG NOT ALL OF IT WILL BE PRINTED. ALSO THE PAGE NUMBER IS WRITTEN OVER THE FIRST HEADER LINE (THE ONE WITH INDEX 0) WITH ITS LEAST SIGNIFICANT DIGIT AT THE LOCATION SPECIFIED BY PARAMETER 4. IT IS USUAL TO KEEP HEADERS SHORT ENOUGH TO FIT WITHIN THE MARGINS YOU EXPECT TO USE.

THE STOP AND NEW LINE CHARACTERS SPECIFIED BY PARAMETER 12 ARE IGNORED IN HEADER LINES.

THE 'H' AND '\*' IN COLUMN 6, LIKE THE OTHER FORMAT CONTROL CHARACTERS, HAVE NO EFFECT IF PARAMETER 7 IS ZERO.

\*\*\*\*\*  
 NEW PAGE NUMBER.  
 \*\*\*\*\*

PAGES ARE USUALLY NUMBERED CONSECUTIVELY, STARTING AT 1.

IF COLUMN 6 IS AN N AND COLUMNS 8-10 CONTAIN A THREE-DIGIT DECIMAL NUMBER, THEN A NEW PAGE NUMBERING SEQUENCE, BEGINNING AT THAT NUMBER, WILL BE BEGUN AT THE TOP OF THE NEXT PAGE.

\*\*\*\*\*  
 FORMAT CHANGE RECORD.  
 \*\*\*\*\*

IF CHARACTER 6 IS AN F AND PARAMETER 7 IS ONE, THEN THIS RECORD IS NOT PRINTED, BUT RATHER IS USED TO CHANGE THE VALUES OF THE PARAMETERS. THE NEW PARAMETERS ARE SPECIFIED EXACTLY AS ON A PARAMETER CARD, CHARACTER 8 OF THIS RECORD CORRESPONDING TO COLUMN ONE OF THE PARAMETER CARD.

IF PARAMETER 7 IS ZERO AT THE TIME THIS RECORD IS READ THEN THE FORMAT CONTROL CHARACTER 'F' IS IGNORED, THE RECORD IS

G (continued)

THE 7094 PRINT PROGRAM.  
FORMAT CONTROL CHARACTERS.  
FORMAT CHANGE RECORD.

R

PRINTED, AND PARAMETERS ARE NOT CHANGED. HENCE PARAMETER 7 CANNOT BE CHANGED FROM ZERO BY THIS MEANS, A PARAMETER CARD BEING USED INSTEAD.

\*\*\*\*\*  
CONTENTS RECORD  
\*\*\*\*\*

IF CHARACTER 6 IS A C AND PARAMETER 7 IS ONE, THEN THIS RECORD IS NOT PRINTED AT THIS POINT IN THE TEXT, BUT IS STORED AS A TABLE OF CONTENTS ENTRY, WITH THE NUMBER OF THE CURRENT PAGE INSERTED AT ITS RIGHT. A PLUS-ZERO CHARACTER MUST NOT BE USED IN A CONTENTS RECORD, SINCE THIS CHARACTER IS USED IN A SPECIAL WAY BY THE STORAGE ROUTINE. THE STOP AND NEW-LINE CHARACTERS (SEE PARAMETER 12) ARE IGNORED. AT MOST 130 CHARACTERS (STARTING AT CHARACTER POSITION 8 OF THE TAPE RECORD) WILL BE STORED.

IF A CONTENTS ENTRY REQUIRES MORE THAN ONE LINE (TO LET THE RIGHT MARGIN MATCH THAT OF THE MAIN LISTING) THE CONTINUATION CARD DESCRIBED BELOW MAY BE USED FOR SECOND AND FOLLOWING LINES.

EACH CONTENTS ENTRY WILL HAVE ITS LEFT MARGIN DETERMINED BY THE VALUE OF PARAMETER 16 AT THE TIME THE ENTRY IS MET IN THE FILE. BUT THE RIGHT MARGIN OF THE TABLE OF CONTENTS IS DETERMINED BY THE VALUE OF PARAMETER 4 AT THE END OF THE FILE.

\*\*\*\*\*  
CONTINUATION RECORD.  
\*\*\*\*\*

IF CHARACTER 6 IS A D AND PARAMETER 7 IS ONE, THEN THIS RECORD IS NOT PRINTED, BUT RATHER IS STORED AS A TABLE OF CONTENTS ENTRY IN THE SAME FORMAT AS THE CONTENTS RECORD, EXCEPT THAT THE PAGE NUMBER IS OMITTED.

THIS FEATURE MAY BE USED TO PROVIDE A TITLE FOR THE TABLE-OF-CONTENTS PAGE AND TO PROVIDE FOR THOSE CONTENTS ENTRIES WHICH REQUIRE MORE THAN ONE LINE.

\*\*\*\*\*  
ELIMINATION OF RECORD.  
\*\*\*\*\*

IF COLUMN 6 IS AN E AND PARAMETER 7 IS NOT ZERO, THEN THIS RECORD WILL BE COMPLETELY IGNORED BY THE PRINT PROGRAM. THIS FEATURE PERMITS THE INCLUSION OF SIGNAL RECORDS OF VARIOUS KINDS (FOR THE USE OF OTHER PROGRAMS) WITHOUT INTERFERING WITH THE PRINTED OUTPUT.

THE 7094 PRINT PROGRAM.  
FORMAT CONTROL CHARACTERS.  
SELECTION CONTROL.

\*\*\*\*\*  
SELECTION CONTROL.  
\*\*\*\*\*

IF PARAMETER 7 IS NOT ZERO AND A RECORD HAS AN S IN COLUMN 6 AND A DIGIT IN COLUMN 7 THEN THAT DIGIT IS COMPARED WITH THE VALUE OF PARAMETER 18. THE RECORD IS PRINTED IF THE DIGIT IN COLUMN 7 IS LESS THAN OR EQUAL TO PARAMETER 18, OTHERWISE IT IS IGNORED.

\*\*\*\*\*  
NEW PAGE WARNING.  
\*\*\*\*\*

IF CHARACTER 6 IS A DIGIT THEN THE ONE OR TWO DIGIT NUMBER IN CHARACTERS 6-7 IS USED AS A PAGE-END WARNING. THE PRESENT RECORD WILL START A NEW PAGE UNLESS THE PRESENT PAGE HAS ROOM FOR AT LEAST N MORE PRINTER LINES (COUNTING THE FIRST LINE OF THIS RECORD AS THE FIRST OF THE N LINES, AND COUNTING ANY BLANK LINES THAT MAY BE CALLED FOR.)

THIS MAY BE USED WHENEVER IT IS UNDESIRABLE (BECAUSE OF A TABLE, PARAGRAPH HEADING, ETC.) TO BREAK A PAGE IN THE MIDDLE OF THE N LINES INVOLVED. ALSO, IF N IS GREATER THAN PARAMETER 8, THIS FEATURE PERMITS FORCING A NEW PAGE WITHOUT CHANGING THE PAGE HEADINGS.

\*\*\*\*\*  
USE SECOND LINE MARGIN.  
\*\*\*\*\*

IF CHARACTER 6 IS AN L THEN THE FIRST LINE OF THIS RECORD IS STARTED AT THE LEFT MARGIN SPECIFIED BY PARAMETER 3 INSTEAD OF THAT SET BY PARAMETER 2. THE OTHER LINES OF THE RECORD, IF ANY, WILL BE SET BY PARAMETER 3, AS USUAL.

THIS IS CONVENIENT WHEN SINGLE LINES ARE DISPLAYED IN RUNNING TEXT, AND THE LINE FOLLOWING THE DISPLAYED LINE IS TO BE TREATED LIKE AN INTERNAL LINE OF THE PARAGRAPH.

\*\*\*\*\*  
NON-PRINTING CHARACTER.  
\*\*\*\*\*

THE SEMICOLON, PUNCHED 11-6-8 ON A CARD, IS A NON-PRINTING CHARACTER WHICH CAN BE USED IN SEVERAL WAYS.

FOR EXAMPLE, IF A BLANK LINE IS DESIRED BETWEEN TWO RECORDS WHEN PARAMETER 5 IS SET TO ZERO, ONE MAY OF COURSE CHANGE PARAMETER 5 TO 1 BY A FORMAT CHANGE RECORD AND THEN CHANGE IT BACK LATER. BUT IT IS EASIER TO INSERT A RECORD CONTAINING ONLY A SEMICOLON IN COLUMN 8, SINCE SUCH A RECORD PRINTS A BLANK LINE.

ALSO, IF THE RIGHT MARGIN IS BEING JUSTIFIED (PARAMETER 11 EQUAL TO 1) AND YOU WANT TO AVOID THE INSERTION OF JUSTIFYING

1094 PRINT PROGRAM.  
NON-PRINTING CHARACTER.

ES AT ANY POINT IN THE LINE, YOU MAY USE A SEMICOLON INSTEAD OF SPACE AT THAT POINT.

IF THE TEXT OF A RECORD ENDS WITH A DOLLAR SIGN, THIS DOLLAR MAY BE FOLLOWED WITH A SEMICOLON TO PREVENT CONFUSING IT WITH TERMINAL DOLLAR SIGN INSERTED AUTOMATICALLY BY THE EDIT PRO-

\*\*\*\*\*  
HYPHENATION RULES.  
\*\*\*\*\*

THE RULES FOR BREAKING WORDS AT THE END OF A LINE (WHEN METER 7 IS EQUAL TO 1) MAY BE SUMMARIZED AS FOLLOWS.

RULE 1. IF A SPACE, VIRGULE OR HYPHEN LIES WITHIN SIX CHARACTERS OF THE RIGHT MARGIN THEN THE LINE IS BROKEN IMMEDIATELY FOLLOWING THAT SPACE, VIRGULE OR HYPHEN, AND NO ADDITIONAL HYPHEN IS INSERTED.

RULE 2. THE PART-WORD CARRIED OVER TO THE NEXT LINE MUST CONTAIN AT LEAST ONE VOWEL OTHER THAN A FINAL E OR THE WORD ENDINGS -ES, -ED.

RULE 3. THE PART-WORD CARRIED OVER TO THE NEXT LINE NEVER BEGINS WITH A VOWEL.

RULE 4. THE PART-WORD CARRIED OVER TO THE NEXT LINE NEVER STARTS WITH A DOUBLED CONSONANT.

RULE 5. THE LINE BREAK NEVER OCCURS BETWEEN THE TWO LETTERS OF THE FOLLOWING SPECIAL PAIRS- CH, GH, PH, SH, TH, WH, OM, VOWEL + N, VOWEL + R; BR, CR, DR, FR, GR, PR, TR, WR.

RULE 6. THE PART-WORD PRECEDING THE BREAK MUST CONTAIN A VOWEL.

THESE RULES USUALLY PROVIDE ACCEPTABLE WORD BREAKS. AN OCCASIONAL VERY BAD BREAK CAN BE AVOIDED BY EDITING A HYPHEN INTO THE LINE INVOLVED TO FORCE THE BREAK WHERE YOU WANT IT.

\*\*\*\*\*  
TAPE DESIGNATION  
\*\*\*\*\*

THE PRINT PROGRAM EXPECTS ITS INPUT TAPE FILE TO BE UNBLOCKED ON SYSTEM TAPE UNIT SYSBR6. IF THIS IS NOT WHAT YOU INTEND, THEN THE PARAMETER CARDS SHOULD BE PRECEDED BY A TAPE DESIGNATION CARD WITH THE CORRECT SYSTEM NAME SYSXZN IN COLUMNS 1-6 FOR UNBLOCKED TAPE, OR THAT NAME PRECEDED BY A MINUS SIGN IN COLUMNS 1-7 FOR A BLOCKED TAPE.

\*\*\*\*\*  
USAGE OF THE SYSTEM  
\*\*\*\*\*

IN GENERAL, ONE OF THE MAIN PROBLEMS ASSOCIATED WITH USING COMPUTERS, ESPECIALLY ON A LARGE SCALE AS AT OUR INSTALLATION, IS THE TIME LAPSE BETWEEN SUBMITTING A JOB TO BE RUN AND RECEIVING THE RESULTS. THUS, IT IS DESIRABLE TO DO AS MUCH DURING ONE ACCESS



THE 7094 PRINT PROGRAM  
USAGE OF THE SYSTEM.

11

TO THE COMPUTER AS POSSIBLE. TO ACCOMPLISH THIS END, THE INFORMATION PACKAGE (IPS) IS DESIGNED SO THAT ANY OR ALL OF THE PROGRAMS BELONGING TO IT MAY BE RUN DURING ONE TIME ON THE COMPUTER, IN ANY ORDER DETERMINED BY THE USER AND AS MANY TIMES AS NEEDED.

IT IS IMPORTANT THAT THE USER BE FAMILIAR WITH THE GENERAL DECK SETUP FOR IPS AND UNDERSTAND THE NECESSARY CONTROL CARDS FOR THE SYSTEM. A MORE GENERAL DISCUSSION WILL BE FOUND IN BCC-351, WHICH DESCRIBES THE INFORMATION PACKAGE (OF WHICH THE PRINT PROGRAM IS ONLY ONE PIECE) AS A UNIT.

FIRST IT IS NECESSARY TO IDENTIFY YOURSELF TO THE SYSTEM AND PROVIDE CERTAIN BOOKKEEPING INFORMATION. THIS IS ACCOMPLISHED WITH THE 'JOB' CARD PUNCHED AS FOLLOWS.

COL. 1 - THE PUNCHES 7,8,9  
COLS. 8-10 - THE WORD 'JOB'  
COLS. 16- - JOB NUMBER, P, YOUR NAME, ESTIMATED TIME IN HUNDRETHS OF HOURS, 999999, 999999

NEXT THE SYSTEM MUST BE TOLD WHICH TAPE DRIVES (OR AUXILIARY STORAGE MEDIUM) ARE TO BE USED AND THE OPERATOR INFORMED OF WHAT FILES TO BE MOUNTED. THIS IS ACCOMPLISHED BY THE 'ASSIGN' CARD (FOR EACH TAPE USED) AS FOLLOWS

COL. 1 - THE PUNCHES 7,8,9  
COLS. 8-13 - THE WORD 'ASSIGN'  
COLS. 16-24 - THE STRING 'CK=SYSXZN' WHERE CK IS THE PHYSICAL UNIT TO BE USED AND SYSXZN IS THE SYMBOLIC NAME REFERENCED BY THE PROGRAM.  
COLS. 26- - COMMENTS TO THE OPERATOR SUCH AS TAPE TO MOUNT.

THE USER SHOULD CHECK WITH THE PERSON TO WHOM HE SUBMITS HIS JOB TO BE SURE THAT THE PHYSICAL HARDWARE (SUCH AS TAPE DRIVES) WHICH HE IS REQUESTING IS AVAILABLE.

NOW IT IS TIME TO GET IPS INTO THE MACHINE. THE FOLLOWING CARD, CALLED AN 'LBRL' CARD, ACCOMPLISHES THIS.

COL. 1 - THE PUNCHES 7,8  
COLS. 8-11 - THE WORD 'LBRL'  
COLS. 16-21 - THE WORD 'INPACK' (FOR INFORMATION PACKAGE)

THE SUB-PROGRAMS, EDIT AND PRINT, ARE EACH OBTAINED BY A SINGLE 'LBRL' CARD. NAMELY,

COL. 1 - THE PUNCHES 7,8  
COLS. 8-11 - THE WORD 'LBRL'  
COLS. 16- - THE WORD 'EDIT' OR 'PRINT' DEPENDING ON THE PROGRAM NEEDED.

FOLLOWING THIS CARD MUST BE THE CARD DECK SPECIFYING INPUTS FOR THAT PROGRAM.

ASSUME, FOR EXAMPLE, THAT YOU WANT TO PRINT A FILE OF BLOCKED RECORDS FROM TAPE NUMBER 100, ON THE USUAL PHYSICAL UNIT A5, WITH

THE 7094 PRINT PROGRAM.  
USAGE OF THE SYSTEM.

12

THE USUAL DESIGNATION SYSBR6. ASSUME FURTHER THAT THE FILE CONTAINS ITS OWN FORMAT RECORDS, EXCEPT FOR PARAMETER 7, WHICH MUST BE SET TO 001 BY A PARAMETER CARD. ASSUME THAT YOUR NAME IS 'DOE' AND YOUR JOB NUMBER IS 1023.

THEN THE FOLLOWING DECK SETUP WOULD BE REQUIRED.

789	JOB	1023,P,DOE,20,999999,999999
780	ASSIGN	A5=SYSBR6 TAPE NO. 100 IS INPUT
78	LBRL	INPACK CALL INFORMATION PACKAGE
78	LBRL	PRINT CALL PRINT PROGRAM
-SYSBR6		TAPE DESIGNATION
07001		PARAMETER CARD

Unclassified  
Security Classification

DOCUMENT CONTROL DATA - R&D		
<small>(Security classification of title, body of abstract and indexing annotation must be entered when the report is prepared)</small>		
1. ORIGINATING ACTIVITY (Corporate author) BOOZ ALLEN APPLIED RESEARCH, INC. 4733 Bethesda Avenue Bethesda, Maryland 20014		2. SECURITY CLASSIFICATION Unclassified
3. REPORT TITLE Mechanization Study of the Reference Library, Johns Hopkins University Applied Physics Laboratory.		
4. DESCRIPTIVE NOTES (Type of report and inclusive dates) Final Report of on-site survey		
5. AUTHOR(S) (Last name, first name, initial) G. A. Kershaw, D. Crowder, J. E. Davis, E. G. Loges, E. Merendini, S. M. Thomas		
6. REPORT DATE September, 1966	7a. TOTAL NO. OF PAGES 116	7b. NO. OF PAGES 7
8a. CONTRACT OR GRANT NO. DSA-7-15489	9a. ORIGINATOR'S REPORT NUMBER(S) 914-1-25	
1. PROJECT NO.	9b. OTHER REPORT NUMBER(S) (Any other numbers that may be assigned this report) AD 640 120	
10. AVAILABILITY LIMITATION NOTICES Distribution of this Document is unlimited		
11. SUPPLEMENTARY NOTES None	12. SPONSORING MILITARY ACTIVITY Defense Supply Agency Defense Documentation Center Cameron Station, Virginia	
13. ABSTRACT The Applied Physics Laboratory (APL) Reference Library uses IBM 7094 and 7040 computers to produce a quarterly list of serials holdings and a quarterly union list of serials, including APL's holdings and those of other participating libraries. The APL Document Library uses these computers to produce an accession list, selective bibliographies in accordance with its SDI program, and reference or demand bibliographies as a result of search requests. The repertoire of programs used has been designated the Information Processing System.		

Best Available Copy

<p>14</p> <p>KEY WORDS</p> <p><b>Digital Computers Information Retrieval Bibliographies Libraries Research and Development</b></p>	LINK A		LINK B		LINK C	
	ROLE	WT	ROLE	WT	ROLE	WT

**INSTRUCTIONS**

1. **ORIGINATING ACTIVITY:** Enter the name and address of the contractor, subcontractor, grantee, Department of Defense activity or other organization (Corporate author) issuing the report.
2. **REPORT SECURITY CLASSIFICATION:** Enter the overall security classification of the reports. Indicate whether "Restricted Data" is included. Marking it to be in accordance with appropriate security regulations.
3. **REPORT AUTOMATIC DOWNGRADING:** As specified in I. D. D. reports 5-209, 10 and Armed Forces Industrial Manual. Enter the group number. Also, when applicable, show that optional marking has been assigned for Group 1 and Group 2 as authorized.
4. **REPORT TITLE:** Enter the complete report title in all capital letters. Titles in all cases should be unclassified. If a classified title cannot be selected without classification, show title of classification in all capitals in parenthesis immediately following the title.
5. **DESCRIPTIVE NOTES:** If appropriate, enter the type of report, e.g., final, progress, summary, annual, or final, or the number of pages when a specific reporting period is required.
6. **AUTHORS:** Enter the name(s) of author(s) as shown on the report. Enter last name, first name, middle initial. If military, show rank and branch of service. The name of the principal author is an absolute minimum requirement.
7. **REPORT DATE:** Enter the date of the report as day, month, year, or month, year. If more than one date appears on the report, or a date of publication.
8. **TOTAL NUMBER OF PAGES:** The total page count should follow normal pagination procedures, i.e., enter the number of pages containing information.
9. **NUMBER OF REFERENCES:** Enter the total number of references cited in the report.
10. **CONTRACT OR GRANT NUMBER:** If appropriate, enter the applicable number of the contract or grant under which the report was written.
11. **DA, V, M, PROJECT NUMBER:** Enter the appropriate military department identification, such as project number, system number, system numbers, task number, etc.
12. **ORIGINATOR'S REPORT NUMBER(S):** Enter the official report number by which the document will be identified and controlled by the originating activity. This number must precede the report.
13. **REPORT NUMBER(S):** If the report has been assigned a report number other than the originator's number, enter this number.
14. **AVAILABILITY STATEMENT NOTES:** Enter any limitation on the availability of the report other than those

imposed by security classification, using standard statements such as:

- (1) "Qualified requesters may obtain copies of this report from DDC."
- (2) "Foreign announcement and dissemination of this report by DDC is not authorized."
- (3) "U. S. Government agencies may obtain copies of this report directly from DDC. Other qualified DDC users shall request through..."
- (4) "U. S. military agencies may obtain copies of this report directly from DDC. Other qualified users shall request through..."
- (5) "All distribution of this report is controlled. Qualified DDC users shall request through..."

If the report has been furnished to the Office of Technical Services, Department of Commerce, for sale to the public, indicate this fact and enter the price, if known.

15. **SUPPLEMENTARY NOTES:** Use for additional explanatory notes.
16. **SPONSORING MILITARY ACTIVITY:** Enter the name of the departmental project office or laboratory sponsoring (sponsoring) the research and development. Include address.
17. **ABSTRACT:** Enter an abstract giving a brief and factual summary of the document indicative of the report, even though it may also appear elsewhere in the body of the technical report. If additional space is required, a continuation sheet shall be attached.

It is highly desirable that the abstract of classified reports be unclassified. Each paragraph of the abstract shall end with an indication of the military security classification of the information in the paragraph represented as (TS), (S), (C), or (R).

There is no limitation on the length of the abstract. However, the suggested length is from 150 to 225 words.

18. **KEY WORDS:** Key words are technically meaningful terms or short phrases that characterize a report and may be used as index entries for cataloging the report. Key words must be selected so that no security classification is required. Identifiers such as equipment model designation, trade name, military project code name, geographic location, may be used as key words but will be followed by an indication of technical content. The assignment of links, roles, and weights is optional.

Best Available Copy