

CLEARINGHOUSE FOR FEDERAL SCIENTIFIC AND TECHNICAL INFORMATION		
Hardcopy	Microfilm	FD
3	3	
ARCHIVE COPY		

AD



AUG 3 1966

TECHNICAL REPORT ECOM-01336-3

DEVELOPMENT OF A LIGHTWEIGHT, CABLE DRIVEN TELESCOPIC MAST

QUARTERLY REPORT

BY
J.R. HARRIS

JULY 1966

DDC
RECORDED
AUG 23 1966
C

ECOM

UNITED STATES ARMY ELECTRONICS COMMAND · FORT MONMOUTH, N.J.
CONTRACT DA28-043 AMC-01336(E)
BROOKS & PERKINS INC.
DETROIT, MICH.

ACCESSIO: W	
SP81	W.ITS. SEC. 107 <input checked="" type="checkbox"/>
DDC	DIFF SECTION <input type="checkbox"/>
UNANNOUNCED	
JUSTIFICATION	<i>Red statement on Doc</i>
BY <i>Sm</i>	
DISTRIBUTION/AVAILABILITY CODES	
DIST.	AVAIL. and/or SPECIAL
<i>1</i>	

NOTICES

Disclaimers

The findings in this report are not to be construed as an official Department of the Army position, unless so designated by other authorized documents.

The citation of trade names and names of manufacturers in this report is not to be construed as official Government indorsement or approval of commercial products or services referenced herein.

Disposition

Destroy this report when it is no longer needed. Do not return it to the originator.

Technical Report ECOM-01336-3

July 1966

**Development of a Lightweight
Cable Driven, Telescopic Mast**

Quarterly Report

29 October 1965 to 28 April 1966

Report No. 3

Contract No. DA28-043-AMC-01336(E)

DA Task No. 1G6 40306 D 488

Prepared By:

J. R. Harris

Brooks & Perkins, Inc.

Detroit, Michigan

For

U.S. Army Electronics Command, Fort Monmouth, N. J.

Distribution Of This Document Is Unlimited

ABSTRACT

This report covers the progress made in the development of a manually actuated, cable driven, telescopic antenna mast, which will meet the requirements of Specification SCL-7805. The mast and its operation is reviewed.

Fabrication of the initial units was delayed approximately fifteen weeks due to a strike of the hourly employees. Three masts have been completed and are being tested. Static load tests have been completed; environmental and cycling tests are approximately 40% complete.

TABLE OF CONTENTS

<u>Description</u>	<u>Page</u>
General Description.....	1
Progress.....	2

LIST OF ILLUSTRATIONS

<u>Figure</u>	<u>Description</u>	<u>Page</u>
I.....	Mast Assembly	4
II.....	Cable and Pulley Configuration.....	5

GENERAL DESCRIPTION

This quarterly report covers the progress made in the development of a manually actuated, cable driven, telescopic mast, Mast AB-903/G, in accordance with Technical Requirement SCL-7805 dated 17 March 1964 and Amendment No. 1 dated 13 July 1965. The six month period covered, 29 October 1965 to 28 April 1966, includes a fifteen week period when progress was limited because of a strike of hourly employees.

The mast is designed to support Antenna AS-1729 and other whip-type antennas used with tactical communications equipment. It is capable of elevation to any height between six feet and thirty feet above the mast base. (See Figure I). The mast is capable of erection and retraction at an angle of 7° with the vertical in winds up to thirty-five miles per hour without guy support, and will survive fifty mile per hour winds with upper guy supports attached. The cable driven mast sections are positively driven up or down with a closed cable routing system illustrated in Figure II. The weight of the mast and its accessories is 45.5 pounds.

The mast is capable of being either ground or vehicular mounted. When ground mounted, it is inserted in a base plate and held vertical by three guy assemblies. It can be erected by two trained men in approximately five minutes.

Mounting bracketry and hardware is provided for installing the mast on the following vehicles.

Carrier, Command Post, light tracked, M577.
Carrier, Command Reconnaissance armored, M114A1/M114.
Truck, 3/4 ton, 4 x 4, M37.
Truck, 2 1/2 ton, 6 x 6, M109.
Truck, 1/4 ton, 4 x 4, M38A1.

The mast can be operated manually using a hand crank attached to the winch, or electrically with an adjunctive motor drive unit which can be mounted to the winch. The motor drive unit consists of a 22 to 28 volt DC motor, a gear reduction unit and integral controls necessary to permit remote operation of the mast. The drive motor package weighs an additional 11.3 pounds.

PROGRESS

The requirements of this contract have been divided into the following three major tasks:

TASK A - DESIGN

- Phase 1 - Design Plan
- Phase 2 - Test Plan
- Phase 3 - Fabrication Drawings

TASK B - INITIAL SERVICE TEST MODELS

- Phase 1 - Fabrication
- Phase 2 - Instruction Manuals
- Phase 3 - Test Program

TASK C - FINAL SERVICE TEST MODELS

- Phase 1 - Fabrication
- Phase 2 - Spare Parts List
- Phase 3 - Final Report

Progress has been made as follows:

TASK A -

- Phase 1 The Design Plan was submitted 30 June 1965, amended 21 September and approved by USAEL 14 October 1965.
- Phase 2 The Test Plan was submitted on 27 July 1965, revised on 17 September 1965 and approved by USAEL 6 October 1965.
- Phase 3 Fabrication drawings have been completed, released for fabrication, and revised for fabrication of the Service Test Models.

TASK B -

- Phase 1** Complete - some minor rework was required to correct deficiencies that occurred during the test program.
- The 1/8 inch diameter pin used to install the winch drive gear failed. The pin was replaced by a 5/32 inch diameter pin.
- The winch gears were changed from full tooth, 14 1/2° pressure angle to stub tooth, 20° pressure angle.
- The pins used to retain the cables on the pulleys were relocated closer to the O.D. of the pulleys to prevent the cable from slipping off.
- The lifting cable at the lower end of tube #2 was rerouted to prevent cable fatigue and excessive cable stretch.
- Phase 2** Preliminary draft copies of the Instruction Manuals was submitted February 2, 1966. Comments on the draft were received April 18, 1966. Corrective action is being taken toward completion of this item.
- Phase 3** Static testing of the mast under simulated wind loading condition is completed. The time required to hand crank the mast to full height, crank handle forces, and the deflection of the mast were all within specified limits. Tests are continuing on the adjunctive drive motor kit, environmental testing and cycling.

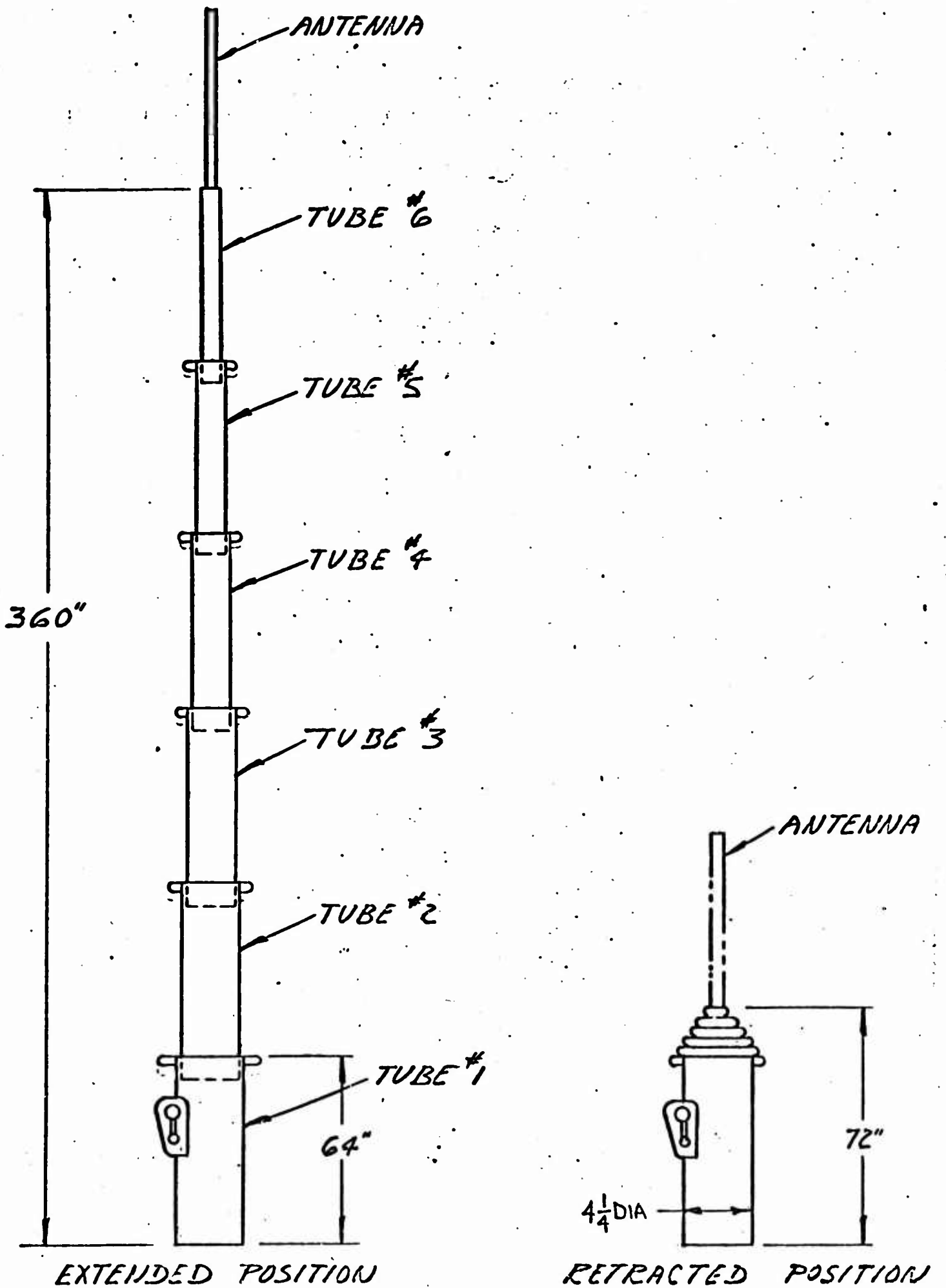

MAST ASSEMBLY

FIGURE I

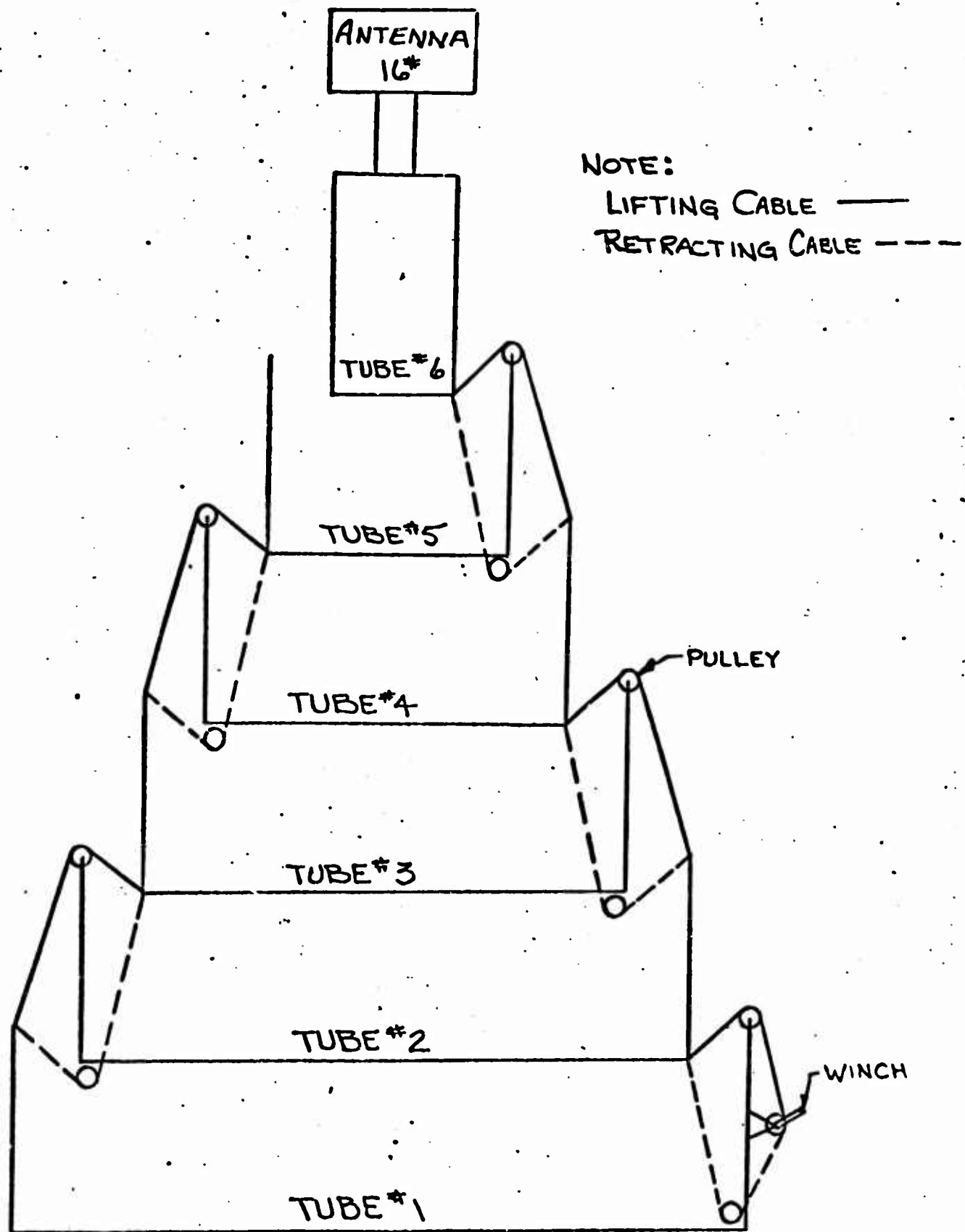

FIGURE II
CABLE & PULLEY CONFIGURATION

BLANK PAGE

DOCUMENT CONTROL DATA - R&D

(Security classification of title, body of abstract and indexing annotation must be entered when the overall report is classified)

1. ORIGINATING ACTIVITY (Corporate author) Brocks & Perkins, Inc. Detroit, Michigan		2a. REPORT SECURITY CLASSIFICATION Unclassified	
		2b. GROUP	
3. REPORT TITLE DEVELOPMENT OF A LIGHTWEIGHT, CABLE DRIVEN, TELESCOPIC MAST.			
4. DESCRIPTIVE NOTES (Type of report and inclusive dates) Quarterly Report 29 October 1965 - 28 April 1966			
5. AUTHOR(S) (Last name, first name, initial) Harris, Joseph R.			
6. REPORT DATE July 1966	7a. TOTAL NO. OF PAGES 10	7b. NO. OF REFS 0	
8a. CONTRACT OR GRANT NO. DA28-043-AMC-01336(E)	8a. ORIGINATOR'S REPORT NUMBER(S) Report 317		
8b. PROJECT NO. 1G6 40306 D 488			
8c. 1G6 40306 D 488 08	8b. OTHER REPORT NO(S) (Any other numbers that may be assigned this report) ECOM-01336-3		
8d.			
10. AVAILABILITY/LIMITATION NOTICES Distribution of this document is unlimited.			
11. SUPPLEMENTARY NOTES		12. SPONSORING MILITARY ACTIVITY U.S. Army Electronics Command Fort Monmouth, N.J. (AMSEL-RD-GDM)	
13. ABSTRACT This report covers the progress made in the development of a manually actuated, cable driven, telescopic antenna mast, which will meet the requirements of Specification SCL-7805. The mast and its operation is reviewed. Three masts have been completed and are being tested. Static load tests have been completed; environmental and cycling test are approximately 40% complete.			

14. KEY WORDS	LINK A		LINK B		LINK C	
	ROLE	WT	ROLE	WT	ROLE	WT
Mast AB903/G						
Antenna Support						
Vehicular Installation						
Motor Operated						

INSTRUCTIONS

1. ORIGINATING ACTIVITY: Enter the name and address of the contractor, subcontractor, grantee, Department of Defense activity or other organization (*corporate author*) issuing the report.

2a. REPORT SECURITY CLASSIFICATION: Enter the overall security classification of the report. Indicate whether "Restricted Data" is included. Marking is to be in accordance with appropriate security regulations.

2b. GROUP: Automatic downgrading is specified in DoD Directive 5200.10 and Armed Forces Industrial Manual. Enter the group number. Also, when applicable, show that optional markings have been used for Group 3 and Group 4 as authorized.

3. REPORT TITLE: Enter the complete report title in all capital letters. Titles in all cases should be unclassified. If a meaningful title cannot be selected without classification, show title classification in all capitals in parenthesis immediately following the title.

4. DESCRIPTIVE NOTES: If appropriate, enter the type of report, e.g., interim, progress, summary, annual, or final. Give the inclusive dates when a specific reporting period is covered.

5. AUTHOR(S): Enter the name(s) of author(s) as shown on or in the report. Enter last name, first name, middle initial. If military, show rank and branch of service. The name of the principal author is an absolute minimum requirement.

6. REPORT DATE: Enter the date of the report as day, month, year; or month, year. If more than one date appears on the report, use date of publication.

7a. TOTAL NUMBER OF PAGES: The total page count should follow normal pagination procedures, i.e., enter the number of pages containing information.

7b. NUMBER OF REFERENCES: Enter the total number of references cited in the report.

8a. CONTRACT OR GRANT NUMBER: If appropriate, enter the applicable number of the contract or grant under which the report was written.

8b, 8c, & 8d. PROJECT NUMBER: Enter the appropriate military department identification, such as project number, subproject number, system numbers, task number, etc.

9a. ORIGINATOR'S REPORT NUMBER(S): Enter the official report number by which the document will be identified and controlled by the originating activity. This number must be unique to this report.

9b. OTHER REPORT NUMBER(S): If the report has been assigned any other report numbers (*either by the originator or by the sponsor*), also enter this number(s).

10. AVAILABILITY/LIMITATION NOTICES: Enter any limitations on further dissemination of the report, other than those imposed by security classification, using standard statements such as:

- (1) "Qualified requesters may obtain copies of this report from DDC."
- (2) "Foreign announcement and dissemination of this report by DDC is not authorized."
- (3) "U. S. Government agencies may obtain copies of this report directly from DDC. Other qualified DDC users shall request through _____."
- (4) "U. S. military agencies may obtain copies of this report directly from DDC. Other qualified users shall request through _____."
- (5) "All distribution of this report is controlled. Qualified DDC users shall request through _____."

If the report has been furnished to the Office of Technical Services, Department of Commerce, for sale to the public, indicate this fact and enter the price, if known.

11. SUPPLEMENTARY NOTES: Use for additional explanatory notes.

12. SPONSORING MILITARY ACTIVITY: Enter the name of the departmental project office or laboratory sponsoring (*paying for*) the research and development. Include address.

13. ABSTRACT: Enter an abstract giving a brief and factual summary of the document indicative of the report, even though it may also appear elsewhere in the body of the technical report. If additional space is required, a continuation sheet shall be attached.

It is highly desirable that the abstract of classified reports be unclassified. Each paragraph of the abstract shall end with an indication of the military security classification of the information in the paragraph, represented as (TS), (S), (C), or (U).

There is no limitation on the length of the abstract. However, the suggested length is from 150 to 225 words.

14. KEY WORDS: Key words are technically meaningful terms or short phrases that characterize a report and may be used as index entries for cataloging the report. Key words must be selected so that no security classification is required. Identifiers, such as equipment model designation, trade name, military project code name, geographic location, may be used as key words but will be followed by an indication of technical context. The assignment of links, rules, and weights is optional.