

ESD-TR-66-101  
ESTI FILE COPY

ESD ACCESSION LIST

ESTI Call No. AL 51728

Copy No.      of      MTR-134

ESD-TR-66-101

ESD RECORD COPY

RETURN TO  
SCIENTIFIC & TECHNICAL INFORMATION DIVISION  
(ESTI), BUILDING 1211

FIELD TEST OF THE MITRE 950 CODER/DECODER

JULY 1966

J. Terzian

Prepared for  
DEPUTY FOR COMMUNICATIONS SYSTEMS  
DIRECTORATE OF COMMUNICATIONS DEVELOPMENT  
ELECTRONIC SYSTEMS DIVISION  
AIR FORCE SYSTEMS COMMAND  
UNITED STATES AIR FORCE  
L. G. Hanscom Field, Bedford, Massachusetts



Distribution of this document is unlimited.

Project 7560

Prepared by  
THE MITRE CORPORATION  
Bedford, Massachusetts  
Contract AF19(628)-5165

ESND

ADD 636 282

This document may be reproduced to satisfy official needs of U.S. Government agencies. No other reproduction authorized except with permission of Hq. Electronic Systems Division, ATTN: ESTI.

When US Government drawings, specifications, or other data are used for any purpose other than a definitely related government procurement operation, the government thereby incurs no responsibility nor any obligation whatsoever; and the fact that the government may have formulated, furnished, or in any way supplied the said drawings, specifications, or other data is not to be regarded by implication or otherwise, as in any manner licensing the holder or any other person or corporation, or conveying any rights or permission to manufacture, use, or sell any patented invention that may in any way be related thereto.

Do not return this copy. Retain or destroy.

FIELD TEST OF THE MITRE 950 CODER/DECODER

JULY 1966

J. Terzian

Prepared for  
DEPUTY FOR COMMUNICATIONS SYSTEMS  
DIRECTORATE OF COMMUNICATIONS DEVELOPMENT  
ELECTRONIC SYSTEMS DIVISION  
AIR FORCE SYSTEMS COMMAND  
UNITED STATES AIR FORCE  
L. G. Hanscom Field, Bedford, Massachusetts



Distribution of this document is unlimited.

Project 7560

Prepared by  
THE MITRE CORPORATION  
Bedford, Massachusetts  
Contract AF19(628)-5165

## FOREWORD

This test series would not have been possible without the cooperation and assistance of the Rome Air Development Center. The GTI-EI communications link and station-operating personnel were made available for these tests by RADC on a no-cost basis.

The author also expresses his appreciation to S. Berkovits and R. Greer of The MITRE Corporation, who devoted many long hours, at times under trying circumstances, to help complete these tests on schedule.

### REVIEW AND APPROVAL

This technical report has been reviewed and is approved.



EDGAR A. GRABHORN, Lt. Colonel, USAF  
Chief, Advanced Development Division  
Deputy for Communications Systems

## ABSTRACT

This document describes the results of a field test held in September and October 1965 on a new error correction/detection equipment developed under MITRE Independent Research. Sponsored by ESD Deputy for Communications, the tests were held in the Caribbean area on a tropospheric scatter communications link made available by the Rome Air Development Center. The tests demonstrated the ability of the equipment to operate successfully in a field environment. A technique of interleaving messages was introduced during the test series and was found to be highly effective in enhancing error correction, particularly in the presence of long error bursts.

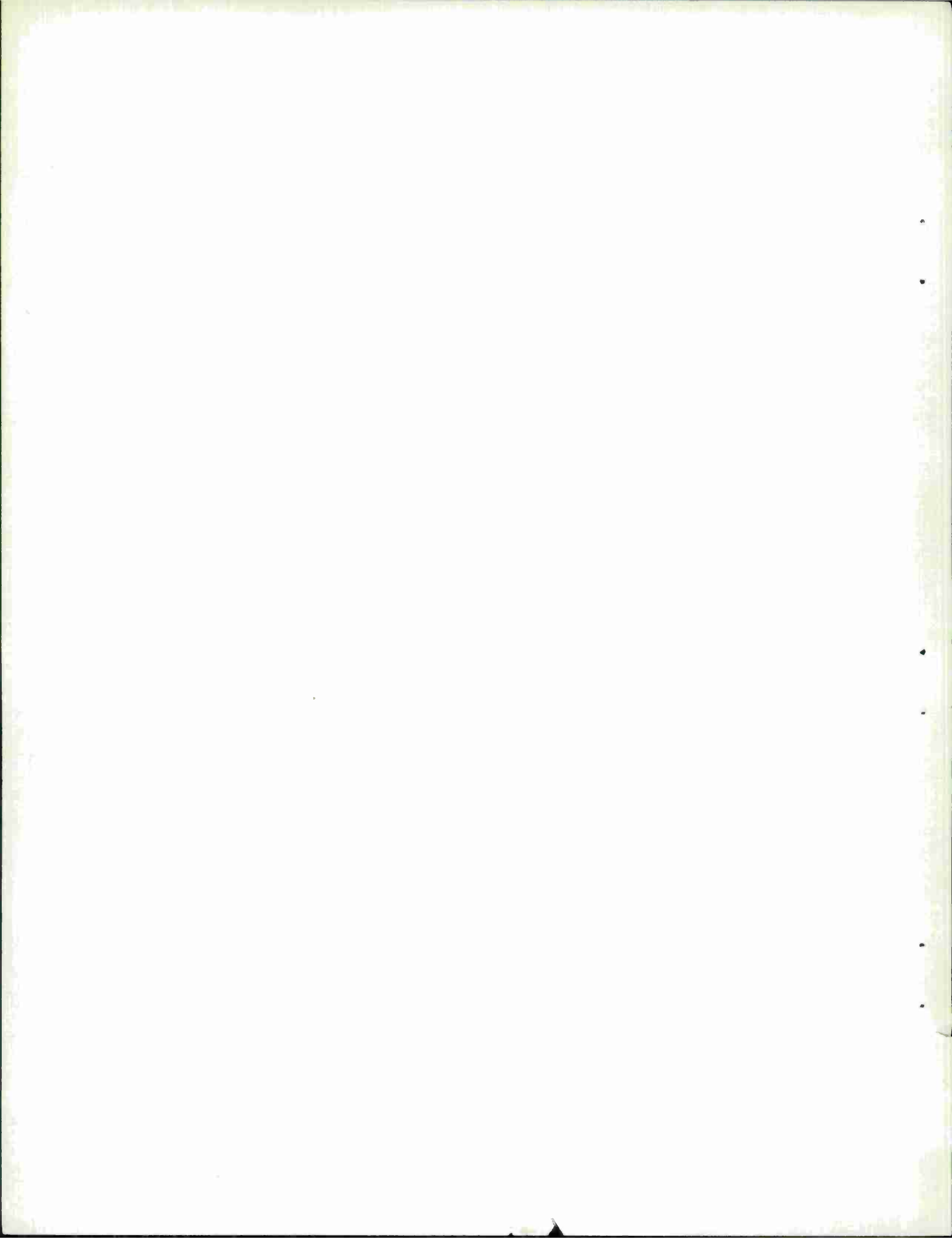

## TABLE OF CONTENTS

	<u>Page</u>
LIST OF ILLUSTRATIONS	vi
LIST OF TABLES	vi
SECTION I INTRODUCTION	1
BACKGROUND	1
CODE DESCRIPTION	2
SECTION II SUMMARY	6
SECTION III EQUIPMENT AND PROCEDURES	7
TEST CONFIGURATION	7
TEST MESSAGE	9
SYNCHRONIZATION	10
TEST SCHEDULE	11
CONDITIONS OF TEST	12
TEST PROCEDURE	13
DIGITAL DATA RECORDED	14
DISCARDED RUNS	17
SECTION IV TEST RESULTS	20
PROPAGATION CONDITIONS	20
ERROR CORRECTION	24
ERROR DETECTION	36
ABORTED RUNS	37
DISTRIBUTION OF BIT ERRORS IN ERROR SYMBOLS	38
SECTION V CONCLUSIONS AND FUTURE PLANS	40

## LIST OF ILLUSTRATIONS

<u>Figure Number</u>		<u>Page</u>
1	Half-Duplex Coder/Decoder Terminal	3
2	Typical Coder/Decoder System	5
3	Test Configuration: 950 Coder/Decoder Tests	8
4	Received Signal Levels on September 14, 15, and 20	21
5	Received Signal Levels on September 21 and 22, and October 5	22
6	Received Signal Levels on October 6 and 7	23
7	Ser Before and After Correction: Interleaved Runs	32
8	Ser Before and After Correction: Non-Interleaved Runs	33
9	Cumulative Distribution of Symbol Errors in Messages Having Errors	34
10	Distribution of Bit Errors in Symbol Errors	39

## LIST OF TABLES

<u>Table Number</u>		<u>Page</u>
I	Check Symbols Used in Test Message	10
II	Schedule of Test Runs	11
III	Run Number 4 on September 14, 1955	18
IV	Run Number 27 on October 5, 1965	19
V	Test Data Log	25
VI	Message and Symbol Errors Before and After Correction: Interleaved Runs	29
VII	Message and Symbol Errors Before and After Correction: Non-Interleaved Runs	30
VIII	Occurrences of Symbol Error Counts > 400 for 16-Message Groupings	36



## SECTION I

### INTRODUCTION

#### BACKGROUND

In January 1964, Project 950.9 was initiated under the MITRE Independent Research for the investigation of a class of error-correcting codes first suggested by N. Zierler and D. Gorenstein in 1961.\* The objectives of this program were to determine the feasibility of implementing the proposed codes with physically and economically realizable hardware, and, if successful, to proceed with the design and fabrication of a prototype equipment capable of use on real communications channels. A preliminary but detailed logical design was prepared for a device capable of encoding and decoding messages in accordance with the proposed codes. This paper design was simulated on the IBM 7030 computer at MITRE and was found to operate successfully; i. e. , the simulated device was able to encode a number of test messages, and, after injection of intentional errors into the coded messages, it was able to locate and correct the errors.

Concurrently, techniques were developed for the modeling of error distributions in digital communications channels. Several real channels were simulated,<sup>†</sup> and close correspondence was obtained between simulated and measured error statistics for these channels. Computations were made to determine the effectiveness of the proposed coder/decoder in correcting errors on the simulated channels. Results indicated that the proposed technique would be highly effective. For example, an analysis was

---

\*N. Zierler and D. Gorenstein, A Class of Error Correcting Codes in  $p^m$  Symbols, J. Soc. Indust. Appl. Math., 9 (1961), 207-214.

†S. Berkovits, E. L. Cohen, and N. Zierler, A Model for Digital Error Distributions, The MITRE Corporation, ESD-TR-65-146, Bedford, Mass., 15 March 1965.

made of the performance of the coder during the worst half hour (excluding long fades) of a bad day on the North Atlantic Tropo Link. During this time, the overall error probability was 0.014. Under these conditions, the analysis showed a mean time between uncorrectable messages of approximately 1 hour, with the coder operating at a bit rate of 1200 bits per second and an information rate of 0.75 (i. e. , 25-percent redundancy in transmitted messages).

Encouraged by these results, it was decided to proceed with phase 2 of the program for the development of a prototype system. In the interest of economy and development speed, it was decided to substitute commercially available computers for the bulk of the system in lieu of the special-purpose hardware designed during phase 1. A pair of half-duplex coder/decoder terminals were developed; each consisted of a DEC PDP-8 computer and a MITRE-designed special processor for performing the finite field arithmetic required by the code. A photograph of one of the half-duplex coder/decoder terminals is shown in Figure 1.

A program for evaluation of the 950 Coder/Decoder was initiated as a sub-task of Air Force Project 7560 in August 1965. The first field test was held during September and October 1965 on a tropospheric scatter link made available by the Rome Air Development Center on a no-cost basis.

#### CODE DESCRIPTION

The family of codes used in the MITRE 950 Coder/Decoder are symbol-correcting block codes. The codes have been referred to as  $(q, n, e)$  codes, where  $q$  is the number of letters or symbols in the alphabet,  $n$  is the number of symbols in the code block, and  $e$  is the number of symbol errors that can be corrected in a code block. For the binary case,  $q = 2^m$ , where  $m$  is the number of bits per symbol. It is convenient in this binary subfamily of codes to select  $n = 2^m - 1$ . The correction of  $e$  symbols then

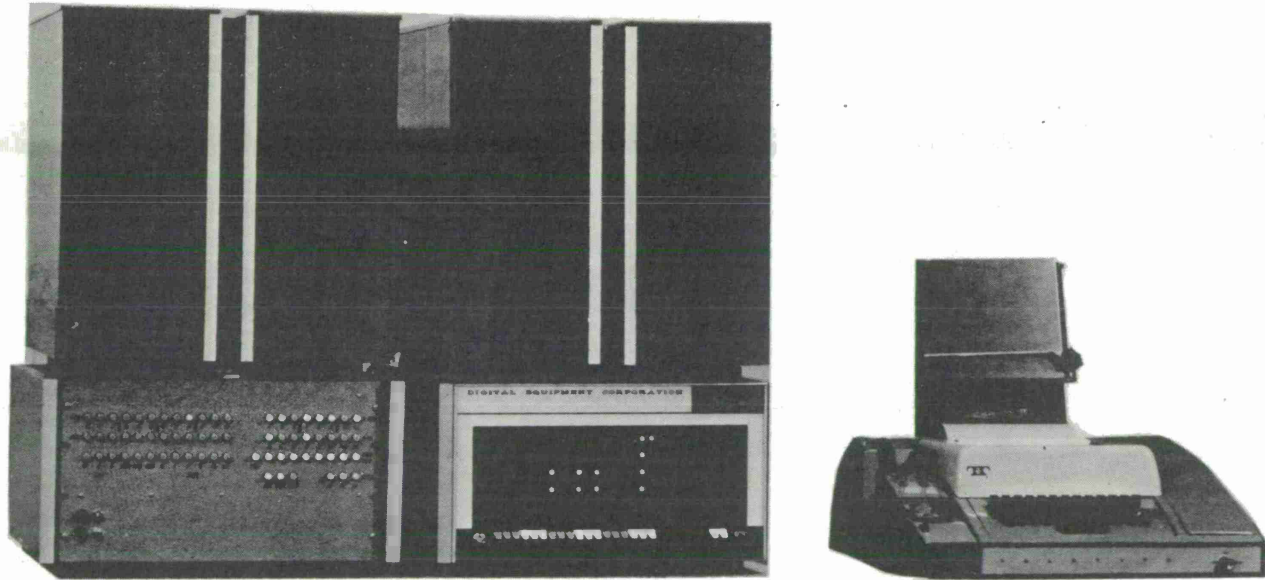

Figure 1. Half-Duplex Coder/Decoder Terminal

requires that  $2e$  check symbols be included in the code block. The parameter values selected for the prototype equipment are:

$$m \quad (\text{bits per symbol}) = 8;$$

$$n \quad (\text{symbols per block}) = 255;$$

$$e \quad (\text{symbols correctable}) = 0 \text{ to } 32;$$

$$2e \quad (\text{check symbols per block}) = 0 \text{ to } 64;$$

$$n-2e \quad (\text{information symbols per block}) = 255 \text{ to } 191.$$

Thus, the prototype operates on messages consisting of 255 eight-bit symbols for a total block length of 2,040 bits. During the test series,  $e$  was fixed at the maximum value (for this prototype) of 32. Hence, each block of 255 symbols contained 191 information symbols, derived from the data source, and 64 check symbols, which were computed as functions of the information symbols. The resulting information rate was  $191/255 = 0.75$ .

A simplified block diagram of a typical system is shown in Figure 2. A continuous stream of information bits is applied from the data source to the input of the encoder. The encoder groups the incoming data bits into symbols and blocks of fixed length, and it adds to each block a fixed number of check symbols which are computed as functions of the incoming information symbols. It should be noted that the incoming information symbols are left intact in the coded messages. The coded messages are sent over the communications channel to the decoder which checks each message for errors. If  $e$  or less errors have occurred in transmission, the message is corrected, and the original message minus the check symbols is sent to the data sink. If more than  $e$  errors have occurred, the message is delivered without correction to the data sink accompanied by a suitable flag indicating that the message was uncorrectable because of excessive errors.

5

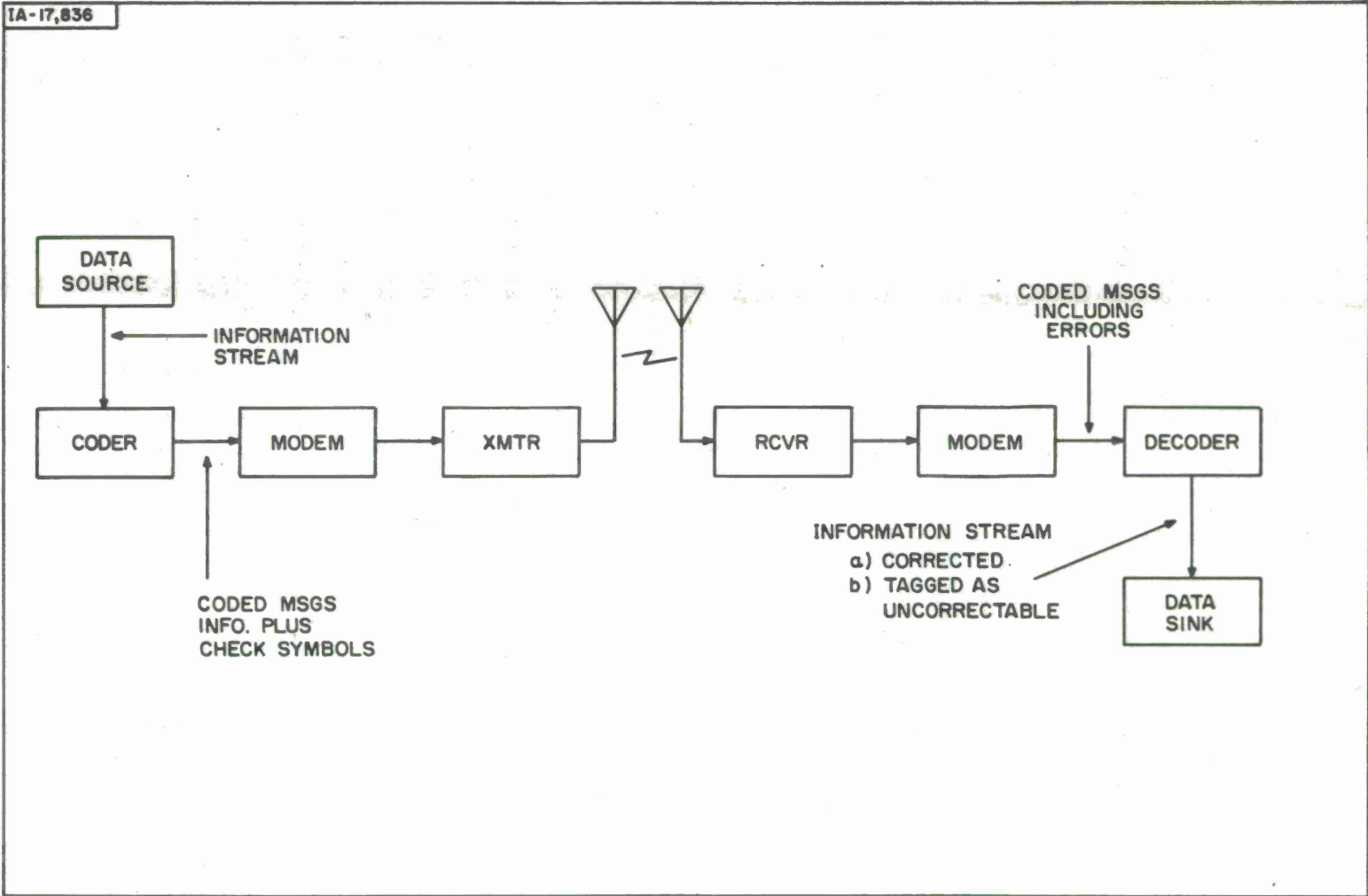

Figure 2. Typical Coder/Decoder System

## SECTION II

### SUMMARY

A prototype error correction/detection equipment, called the MITRE 950 Coder/Decoder, has been developed under MITRE Independent Research Project 950.9. This equipment is intended for use on tropospheric scatter and HF digital communication channels for the purpose of error control.

The prototype system was tested under Air Force Project 7560 on a tropospheric scatter communications channel between Grand Turk Island in the Bahamas and East Island, Puerto Rico.

The tests have demonstrated the ability of the error corrector to operate successfully in a field environment.

During the test period, normal error rates on the channel were observed to be in the order of  $10^{-6}$ . The channel was intentionally degraded to give error rates of approximately  $10^{-3}$  to enable evaluation of the error corrector. Degradation was achieved by power reduction and elimination of diversity.

The error distributions on the degraded channel contained a large number of very long error bursts due to the slow fading of the normally strong signal. A technique of interleaving, introduced during the tests, was found to be highly effective in correcting errors in the presence of long bursts. For the entire test series, 64 percent of the messages with errors in them were corrected when interleaving was not employed. With interleaving, 97 percent of the messages with errors in them were corrected.

The development and test program will continue to permit incorporation of more extensive interleaving and to enable evaluation of the improved system in subsequent field tests.

## SECTION III

### EQUIPMENT AND PROCEDURES

#### TEST CONFIGURATION

The tests were conducted on a 375-mile tropospheric scatter communications link between Grand Turk Island in the Bahamas and East Island, Puerto Rico. To facilitate maintenance of the 950 Coder/Decoder, both data terminals were located at East Island, with the test signal being looped at Grand Turk for retransmission to East Island. The radio equipment used was the REL MRC-98 radio set. Sixty-foot antennas with vertical polarization were used at both sites.

A diagram of the test installation is shown in Figure 3. A fixed, coded test message of 2,040 bits was emitted serially by the transmitting PDP-8 computer. The test message was tone-modulated by a Collins AN/GSC-4 modem and applied to one-voice channel of a 24-channel FDM multiplexer. A 2075-cycle-per-second audio tone was applied to a second channel of the multiplexer. The remaining channels of the multiplexer at East Island were unloaded. The output from the multiplexer was applied to the transmit section of the MRC-98 and sent over the air on a 787-megacycle carrier at a power level of 5 kilowatts. Space-diversity reception was employed at Grand Turk. As indicated in Figure 3, the signal was demodulated, combined, amplified, and demultiplexed. The test message and the 2075-cycle-per-second tone at the demultiplexer output were connected at audio level to 2 channels of the 24-channel multiplexer at Grand Turk; the remaining channels of the multiplexer were loaded with white noise at -5 dbm. The multiplexer output was applied to the transmitter and sent out on a carrier frequency of 882 megacycles per second. The power levels from the Grand Turk transmitter were held constant during a given run but were varied from 50 watts to 5 kilowatts between runs. Both diversity and non-diversity receptions were employed at East Island, with the conditions being held

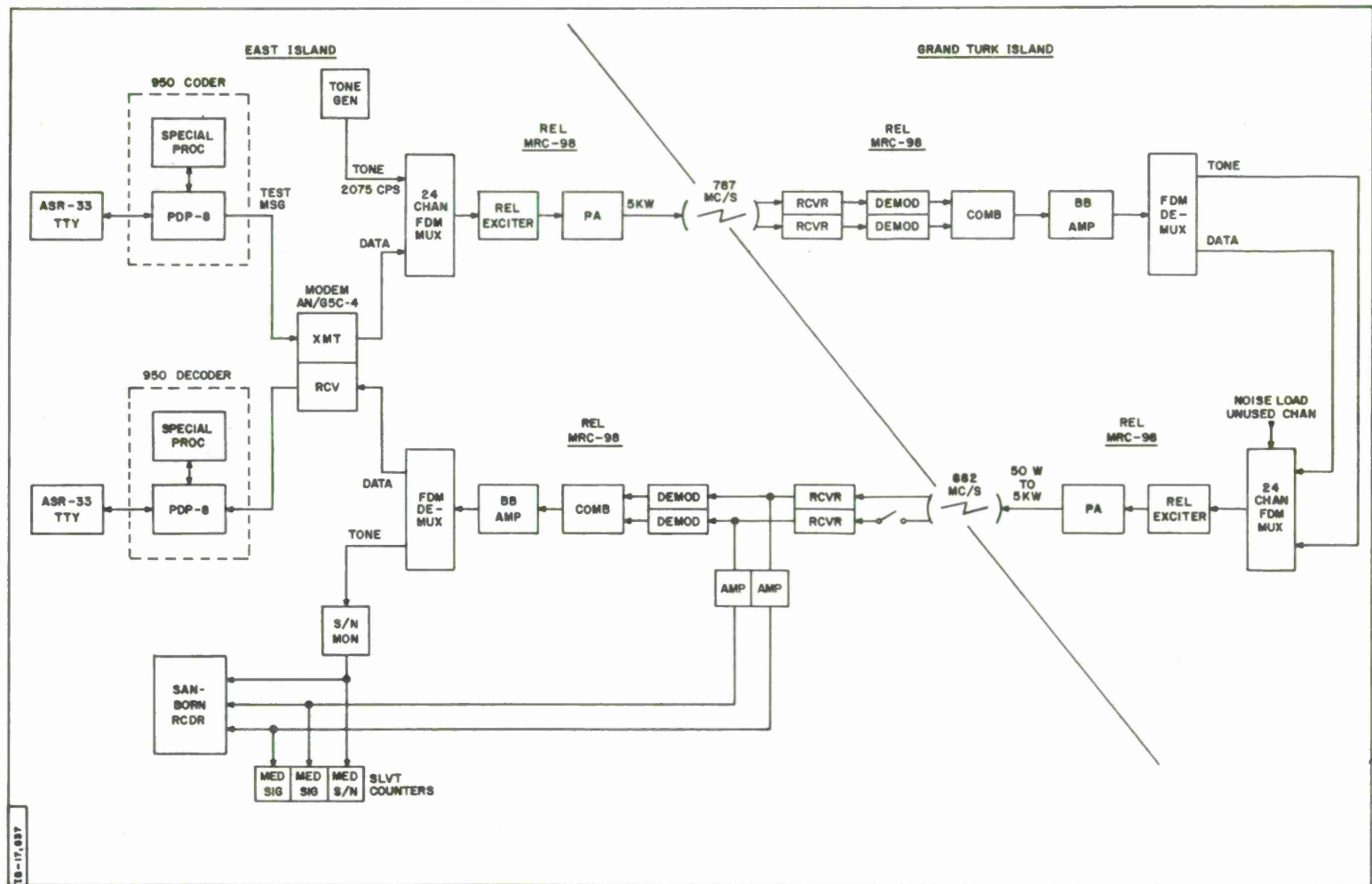

Figure 3. Test Configuration: 950 Coder/Decoder Tests

18-17,887



constant during any given run. The received signal at East Island was demodulated, combined, amplified, and demultiplexed, as shown. The test message from the demultiplexer was converted back to digital by the modem and applied to the receiving PDP-8 for decoding and processing. The 2075-cycle-per-second tone from the other demultiplexer channel was applied to a Philco signal-to-noise (S/N) monitor, and the S/N ratio from the monitor was recorded on one channel of an eight-channel Sanborn recorder. The carrier levels of the two receivers and the combiner output were also recorded on the Sanborn recorder. Median signal level and median S/N ratio were obtained from two arrays of SLVT counters. Each counter within an array was calibrated to trigger at a different power level. All counters were reset to zero at the beginning of a run. Median levels were derived by interpolation from the counter readings at the end of each run.

#### TEST MESSAGE

As indicated in Section II, the test message was composed of 255 eight-bit symbols for a total of 2,040 bits. The information portion of the test message was in English text using a modified 8-bit ASCII teletype code. Approximately equally weighted with zeros and ones, the message contained 1,032 ones and 1,008 zeros.

The information portion of the test message consisted of a "carriage-return" and a "line-feed" symbol followed by the English text below:

```
MITRE 950 CODER/DECODER TEST ---- ABLE BAKER CHARLIE DOG  
EASY FOX GEORGE HOW ITEM KING LOVE MIKE NAN OBOE PETER  
QUEEN ROGER SUGAR TABLE UNCLE VICTOR WAGON XRAY YOKE  
ZEBRA 1234567890:-;./
```

The 64 check symbols derived from the information portion of the message by the coding process are listed in Table I in Octal notation.

Table I

## Check Symbols Used in Test Message

1 - 225	17 - 341	33 - 265	49 - 211
2 - 120	18 - 027	34 - 053	50 - 163
3 - 306	19 - 132	35 - 275	51 - 131
4 - 113	20 - 067	36 - 215	52 - 007
5 - 005	21 - 377	37 - 071	53 - 372
6 - 270	22 - 061	38 - 061	54 - 373
7 - 152	23 - 332	39 - 363	55 - 011
8 - 251	24 - 364	40 - 044	56 - 220
9 - 275	25 - 230	41 - 372	57 - 126
10 - 274	26 - 267	42 - 360	58 - 056
11 - 213	27 - 260	43 - 044	59 - 103
12 - 107	28 - 171	44 - 376	60 - 351
13 - 261	29 - 264	45 - 254	61 - 264
14 - 322	30 - 343	46 - 321	62 - 171
15 - 112	31 - 312	47 - 256	63 - 377
16 - 003	32 - 274	48 - 201	64 - 032

## SYNCHRONIZATION

Synchronization requirements for the code may be considered to exist at three levels: bit sync, symbol sync, and block or message sync. Bit synchronization insures that the transmitting and receiving clocks are in step, which enables the incoming bit stream to be sampled at the appropriate instants in the receiving modem. Symbol synchronization insures that the 8-bit groupings of the received bit stream are correctly framed to correspond to the transmitted symbols. Block synchronization insures the 255 symbol groupings made by the decoder are in step with the 255 symbol messages sent from the transmitter.

Bit synchronization is established and maintained by the modem, which in this case, is the AN/GSC-4. Symbol and block synchronization are established by the decoder. Symbol and block synchronization are obtained by means of a synchronizing pattern, which is sent by the transmitter prior to the initiation of coded messages.

The synchronization pattern consists of an ordered sequence of all 8-bit numbers from zero (00000000) to 254 (11111110). In the complete absence of noise, it would be possible to establish symbol and block synchronization after receipt of any three successive symbols of the synchronization pattern. Since the synchronization pattern cannot be considered to be noise-free, 8 sync sequences (0 to 254) were transmitted at the beginning of each test run to permit the synchronization to be established reliably.

#### TEST SCHEDULE

The tests were conducted over the period from 14 September till 7 October 1965. Because of the heavy commitments on the test link during this period, it was necessary to time-share the test facilities with other users. Thus, only a small portion of the total time period was available for testing of the 950 Coder/Decoder. A total of 58 test runs was made. Of these, 33 runs were of 30-minute duration and 25 were of 10-minute duration. The schedule of runs is shown in Table II.

The actual time on the air and amount of data collected were somewhat less than indicated in Table II, since some of the runs were aborted because of equipment and operational difficulties.

Table II  
Schedule of Test Runs

1965 Date	No. of Runs	Run Length in Minutes	Total Test Time
14 August	4	30	2 hr.
15 August	4	30	2 hr.
20 August	4	30	2 hr.
21 August	4	30	2 hr.
22 August	4	30	2 hr.
5 October	2	30	
	19	10	4 hr. 10 min.
6 October	5	30	
	4	10	3 hr. 10 min.
7 October	6	30	
	2	10	3 hr. 10 min.

## CONDITIONS OF TEST

### Bit Rate

All except three test runs were made at a bit rate of 2400 bits per second. Runs number 10, number 11, and number 57 were made at 1200 bits per second to demonstrate the ability of the coder/decoder to operate at bit rates other than 2400 bits per second.

### Power Levels and Diversity

During the test period, propagation conditions were such that extremely low-bit error rates would have been experienced if full power and diversity reception had been employed. To demonstrate this fact, run number 7 was made with 5-kilowatt transmitted power and dual diversity reception at East Island and Grand Turk Island. Of a total of  $4.284 \times 10^6$  bits transmitted during the half-hour run, only 3 bits were in error before correction.

To get error rates high enough to permit evaluation of the error corrector, it was found necessary to introduce intentional degradation in part of the communications link. The link from East Island to Grand Turk Island was kept essentially error-free by maintaining 5-kilowatt transmitted power from East Island and dual diversity reception at Grand Turk Island for all runs. On the return link, however, power levels and diversity conditions were varied from run to run in an attempt to give bit error rate in the area of  $10^{-3}$ . The power levels and diversity conditions employed for each run are presented in Section IV.

### Interleaving

The intentional degradation of the normally strong signal levels experienced during the tests resulted in a high incidence of long error bursts. This condition is attributed to the slow-fade characteristics observed on signal intensity at the receiver inputs. The slow fades, when brought below receiver threshold by intentional reduction of transmitted power, gave rise to long bursts of errors.

To improve the ability of the prototype to give effective correction in the presence of long error bursts, the computer programs were modified in the field to incorporate interleaving of messages in groups of four. Thus, instead of sending complete messages in sequence, the transmitter would send the first symbol of four separate messages followed by the second symbol of these four messages and so on until all symbols of a four-message group had been transmitted. The process was then continued for succeeding four-message groups. It can be seen that an error burst spanning, for example, four symbols would now contribute one symbol error to each of four messages rather than four symbol errors to one message.

Because of memory limitations in the prototype equipment and limited reprogramming time during the test, it was not possible to provide continuous decoding of messages when interleaving was employed. On the interleaved runs, while the decoder was processing a group of four messages, the succeeding group was disregarded because of the lack of additional buffer storage space in memory. Thus, only alternate four-message groups were accepted for processing. This procedure, though reducing the amount of test data collected during the interleaved runs, did not affect the validity of the results obtained. The restriction, of course, will be removed prior to any future tests or operational use of the equipment.

#### TEST PROCEDURE

The following is a summary of the steps required in the execution of each test run. The first eight steps were executed only in cases where new calibrations or settings were required over those used in the previous run.

1. Load program (interleaved or non-interleaved) into computers.
2. Set run length (10 minutes versus 30 minutes) at console of decoding PDP-8 computer.
3. Calibrate strip charts.

4. Adjust transmitter power at Grand Turk Island.
5. Insert attenuators at East Island Receiver, if required.
6. Reconfigure diversity condition at East Island.
7. Select desired bit rate on AN/GSC-4 modem.
8. Adjust modem transmit and receive signal levels.
9. Reset all SLVT counters to zero.
10. Start the decoding PDP-8. The decoder now searches for the sync pattern.
11. Simultaneously start the transmitting PDP-8, the SLVT counters, and the strip charts.

Upon execution of step 11, the transmitter sends the sync pattern followed by continuous transmission of the test messages. The decoder synchronizes on the sync pattern and then processes the incoming data messages which follow. When the required number of messages have been received for the run, the decoder stops accepting messages, prints out summary data for the run, and halts. The SLVT counters and strip charts are halted; counter readings are taken, all paper records are marked and removed to terminate the run.

#### DIGITAL DATA RECORDED

In addition to its role as an error corrector, the PDP-8 computer was utilized for the collection, reduction, and recording of test data. The device used for the test data outputs was the ASR-33 100 WPM teletypewriter, which is a standard I/O device on the PDP-8. Data was recorded simultaneously on page copy and on 8-channel punched paper tape.

Error data were printed out in real time in the form of a 6-digit number for each message received. The 6-digit number contained three 2-digit fields, E<sub>1</sub>, E<sub>2</sub>, and E<sub>3</sub>, which denote the following:

- $E_1$  - number of symbol errors in the message prior to decoding;
- $E_2$  - number of symbol errors found by the decoder; and
- $E_3$  - number of symbol errors in the message after decoding.

$E_1$  and  $E_3$  were obtained by comparison against a replica of the correct test message which was stored in the decoding computer's memory. For messages with 32 or less errors,  $E_1 = E_2$ , and  $E_3 = 0$ . For uncorrectable messages, i. e. , those having more than 32 errors,  $E_1 = E_3$ , and  $E_2$  is any number from 1 to 32. This indicates that the decoder, though initially guessing that  $E_2$  errors had occurred, had decided in a final validity test that the number of errors were, in fact, excessive and no correction was attempted. The indicated relationships between  $E_1$ ,  $E_2$ , and  $E_3$  were observed to hold for all printouts without exception.

In addition to the real time message by message printouts above, the computer collected and stored pertinent data during each run for printout at the end of the run. The summary data printed out at the end of a run consisted of the following steps.

1. Total number of messages processed.
2. Total number of bit errors before correction.
3. Total number of symbol errors before correction.
4. Total number of messages corrected.
5. Total number of messages uncorrectable due to excessive errors.
6. Distribution of error-free intervals, i. e. , the number of correct bits between bits in error. This was quantized into the number of occurrences during the run for error-free intervals of 0, 1, 2, 3, 4-7, 8-15, 16-31, etc. , to  $2^{22} - 2^{23} - 1$ . The length of the last error-free interval of a run was printed out separately, since this interval was not

bounded on the terminal end by an error bit and could not properly be placed in one of the bounded groupings.

7. Distribution of bit errors in symbol errors, i. e. , number of symbols having 1, 2, 3... 8 bits in error. This printout was not incorporated until run number 19 and could be obtained only on non-interleaved transmissions because of memory limitations. Accordingly, these data were available only for runs 19, 20, 54, and 55.

Because of the limited printing speed of the teletypewriter, all printouts were made in hexadecimal (radix 16) notation. In this notation, each digit position assumes 1 of 16 values. Ordinarily Arabic numerals were used to represent hexadecimal digits 0-9 and the letters A-F for digits 10-15. The examples below illustrate the notation used.

Hexadecimal Notation	Quantity Represented	Equivalent Decimal Notation
8	$8 \times 16^0$	8
C	$12 \times 16^0$	12
27	$2 \times 16^1 + 7 \times 16^0$	39
FB	$15 \times 16^1 + 11 \times 16^0$	251
A3F	$10 \times 16^2 + 3 \times 16^1 + 15 \times 16^0$	2623

Typical computer printouts are illustrated in Tables III and IV. Table III shows the printout for the first 400 messages of run number 4, a non-interleaved run. Each horizontal line represents the printout for eight messages. Corrected messages are underlined. Uncorrectable messages (due to excessive errors) are circled.



Table IV shows the printout for the termination of run number 27, an interleaved run. As before, corrected messages are underlined. There were no uncorrectable messages in this run. The six hexadecimal numbers immediately below the message printout represent the following:

<u>Hexadecimal Number</u>	<u>Decimal Equivalent</u>	<u>Data Represented</u>
15E	350	Total messages in run
08C	140	Number of messages corrected
000	000	Number of messages uncorrectable
0003FB	955	Number of bit errors before correction
258	600	Number of symbol errors before correction
000A1C	2588	Last error-free interval

The vertical column of numbers at the end of the run represent the error-free intervals experienced.

#### DISCARDED RUNS

Data from some of the test runs were inadmissible because of equipment malfunctions or operational errors which were known to have occurred during the run. Of a total of 58 runs, 14 were discarded because of equipment or operational difficulties. Discarded runs are discussed in more detail in Section IV.



Table IV

Run Number 27 on October 5, 1965

060600	050500	090900	0C0C00	000000	000000	000000	000000
010100	000000	010100	020200	0A0A00	090900	080800	0A0A00
000000	000000	000000	000000	050500	020200	050500	060600
000000	000000	000000	000000	000000	000000	000000	000000
000000	000000	000000	000000	060600	040400	060600	050500
000000	000000	000000	000000	000000	000000	010100	010100
000000	000000	000000	000000	050500	030300	050500	070700
000000	000000	000000	000000	000000	000000	000000	000000
050500	040400	050500	020200	000000	000000	000000	000000
0D0D00	0D0D00	070700	0B0B00	050500	040400	050500	050500
000000	000000	000000	000000	000000	000000	000000	000000
000000	000000	000000	000000	060600	060600	050500	060600
000000	000000	000000	000000	020200	020200	030300	020200
000000	000000	000000	010100	000000	000000	010100	010100
000000	000000	000000	000000	000000	000000	000000	000000
000000	000000	000000	000000	020200	010100	000000	020200
000000	000000	000000	000000	000000	000000	010100	000000
000000	000000	000000	000000	000000	000000	000000	000000
000000	000000	000000	000000	000000	000000	000000	000000
000000	000000	000000	000000	000000	000000	000000	000000
000000	000000	000000	000000	000000	000000	000000	000000
000000	000000	000000	000000	000000	000000	000000	000000
000000	000000	000000	000000	000000	000000	000000	000000
0A0A00	0C0C00	090900	070700	000000	000000	000000	000000
0A0A00	070700	030300	090900	000000	000000	000000	000000
090900	0A0A00	080800	0A0A00	000000	000000	000000	000000
000000	000000	000000	000000	010100	000000	010100	010100
000000	000000	000000	000000	000000	000000	000000	000000
030300	020200	010100	030300	000000	000000	000000	000000
000000	000000	000000	000000	000000	000000	000000	000000
000000	020200	010100	010100	010100	010100	000000	000000
15E 08C 000 0003BF 258 000A1C							
00008C							
00007C							
00005E							
00004E							
0000B3							
00006E							
00002B							
00000E							
001							
00C							
008							
01C							
063							
000							
003							
00D							
00C							
001							
000							
000							
000							
000							
000							
000							
000							
000							
000							

IB-17,846

SECTION IV  
TEST RESULTS

PROPAGATION CONDITION

As previously indicated, the periods during which the tests were conducted were periods of high signal strength necessitating intentional signal degradation to achieve error rates high enough to enable evaluation of the error corrector. The resulting error distributions were quite different from those expected during periods of normally poor signal propagation. During the test period, it was observed that, for the most part, variations in signal power levels at the receiver input were relatively slow with negative signal excursions or fades often lasting for periods in excess of a second. Although most of these fades would normally not have been deep enough to cause errors, the intentional signal reduction brought some of the long fades below receiver threshold, thereby causing exceptionally long error bursts. The high incidence of long error bursts gave rise to frequent cases of messages being uncorrectable because of excessive errors. As will be seen in the following sections, the interleave technique introduced during the tests was quite effective in improving performance during the long error bursts.

The conditions of slow fading described above were experienced on every day of the tests except one. On the afternoon of 5 October 1965, the channel manifested rapid fade rates more closely resembling those expected during the late winter months when propagation conditions are normally poor. The station operator at East Island attributed this condition to the passage of a cold front at the time. It is significant to note that, although over 2,000 messages had errors in them during the 3-1/2 hours of testing on 5 October, all errors were corrected on that day.

Figures 4, 5, and 6 illustrate sample records of signal power levels at the receiver inputs as traced by the Sanborn Recorder. The difference in fade rates between the records for 5 October and all other days of the test is

IB-17,838

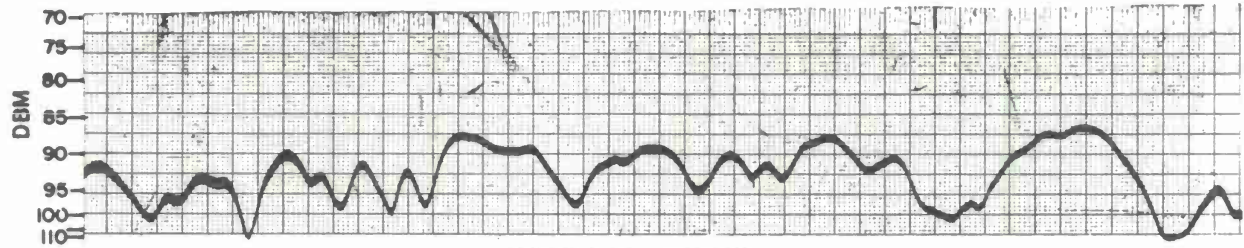

RUN No. 3 9/14/65

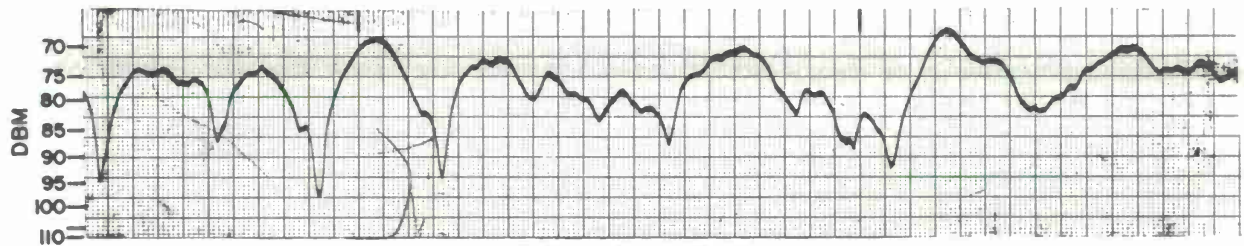

RUN No. 7 9/15/65

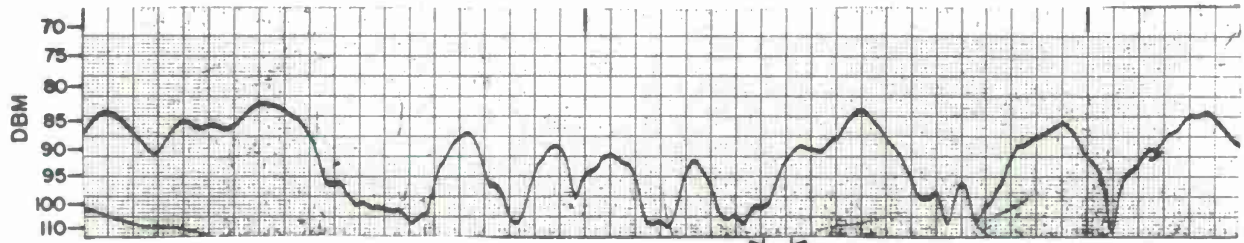

RUN No. 10 9/20/65 2 SEC

Figure 4. Received Signal Levels on September 14, 15, and 20

1B-17,839

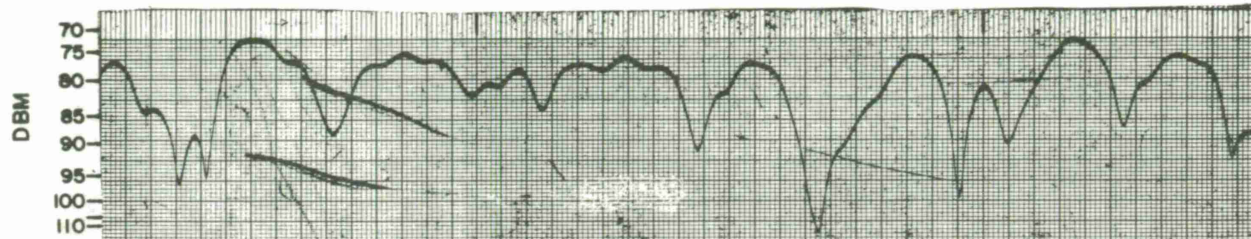

RUN No.15 9/21/65

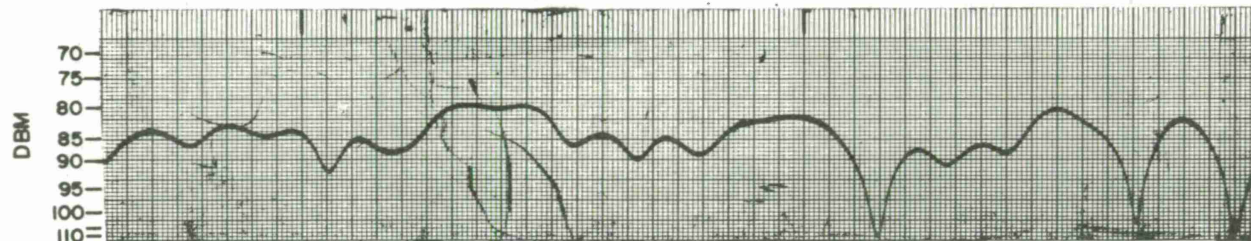

RUN No.17 9/22/65

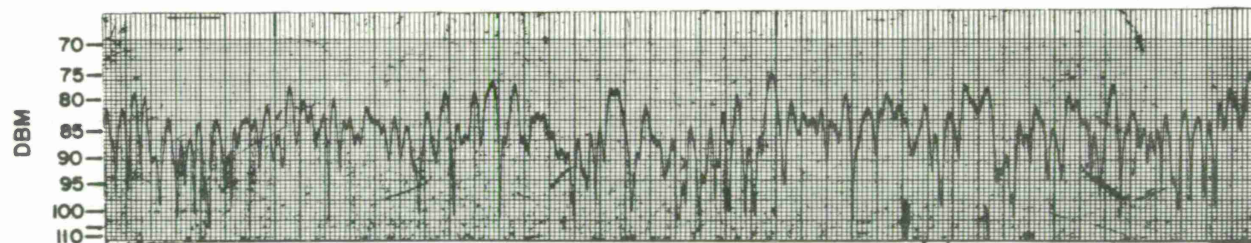

RUN No.25 10/5/65

→ ← 2 SEC

FIG. 4. 2  
RECEIVED SIGNAL LEVELS  
9/21, 9/22, 10/5

Figure 5. Received Signal Levels on September 21 and 22, and October 5

IB-17,840

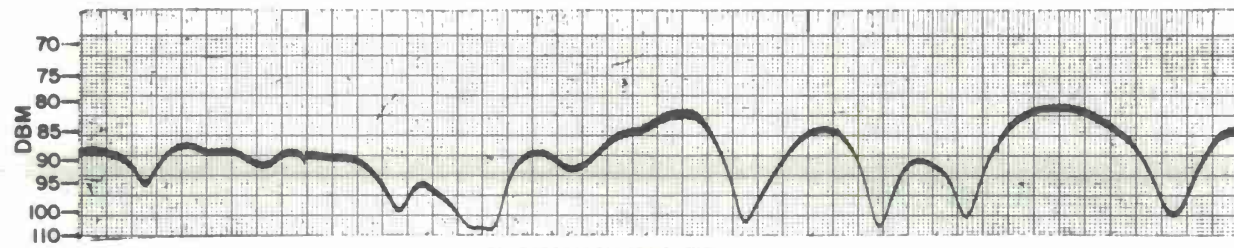

RUN No. 50 10/6/65

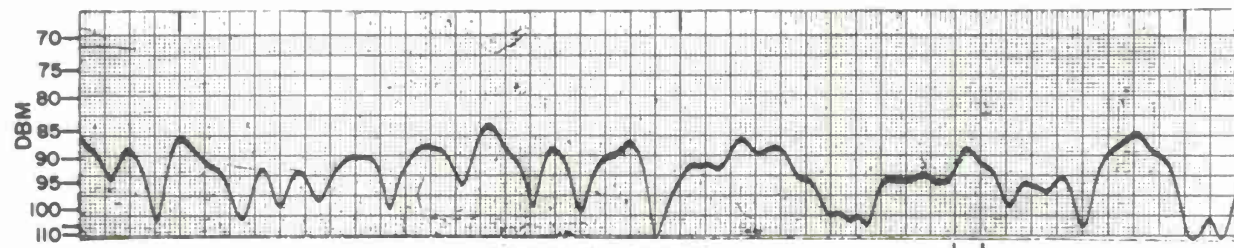

RUN No. 51 10/7/65

→ ← 2 SEC

23

Figure 6. Received Signal Levels on October 6 and 7

apparent from these figures. The samples shown in Figures 4, 5, and 6 are quite representative of those experienced throughout the test period.

#### ERROR CORRECTION

Because of the high incidence of long error bursts on the degraded channel, the error correction provided initially by the decoder fell short of expectations. To improve performance in the presence of long bursts, the technique of interleaving was introduced during run 9 on 20 September 1965. Most subsequent test runs were made in the interleaved mode. For the entire test series, a total of 19,425 test messages were sent in the interleaved mode, and 16,800 messages were sent in the non-interleaved mode. With non-interleaved operation, 64 percent of all messages having errors in them were corrected; when interleaving was employed, 97 percent of all messages with errors in them were corrected.

The summary data for all successful runs of the test series are shown in chronological order in Table V. Data from aborted runs are not included since such data were either incomplete or of questionable validity. An explanation of the column headings of Table V follows.

1. Run No. - Chronological number assigned to each run.
2. Date - Self-explanatory.
3. Start Time - Self-explanatory.
4. Run Length, Minutes - Self-explanatory.
5. Run Length, Messages - The total number of messages transmitted during the run. The number of messages sent during a given interval of time depends not only on bit rate, but on whether or not interleaving was employed (cf. Section III).
6. Bit Rate - Self-explanatory.
7. INT - The YES/NO entries indicate whether or not interleaving was employed.



Table V  
Test Data Log

Run No.	Date	Start Time	Run Length		Bit Rate	INT	DIV	PT	Median Signal Level		Median S/N	C BLOCKS	E BLOCKS	Symbol Errors	Bit Errors	BER
			Min.	Msgs.					Rev #1	Rev #3						
4	9/14	1650	30	2,100	2,400	No	No	500	-78	---	36	65	6	846	1,012	$2.38 \times 10^{-4}$
7	9/15	1637	30	2,100	2,400	No	Yes	5,000	-75	-74	40	3	0	3	3	$7.00 \times 10^{-7}$
8	9/15	1711	30	2,100	2,400	No	No	5,000	-74	---	41	22	1	166	179	$4.18 \times 10^{-5}$
9	9/20	0916	30	1,050	2,400	Yes	No	500	-96	---	36	89	10	1,325	2,406	$1.12 \times 10^{-3}$
10	9/20	0949	30	525	1,200	Yes	No	500	-89	---	37	137	0	857	1,787	$1.66 \times 10^{-3}$
11	9/20	1648	30	525	1,200	Yes	No	1,000	-86	---	39	94	0	338	551	$5.13 \times 10^{-3}$
13	9/21	0849	30	1,050	2,400	Yes	No	1,000	-80	---	40	85	0	210	243	$1.13 \times 10^{-3}$
14	9/21	0923	30	1,050	2,400	Yes	No	700	-81	---	39	91	0	432	662	$3.08 \times 10^{-4}$
15	9/21	1631	30	1,050	2,400	Yes	No	1,000	-82	---	38	57	0	459	821	$3.83 \times 10^{-4}$
16	9/21	1706	30	1,050	2,400	Yes	No	700	-82	---	38	95	4	1,338	2,837	$1.32 \times 10^{-3}$
17	9/22	0950	30	1,050	2,400	Yes	No	1,000	-85	---	36	76	8	1,376	3,154	$1.47 \times 10^{-3}$
18	9/22	1023	30	1,050	2,400	Yes	No	1,000	-84	---	36	58	28	2,252	4,827	$2.25 \times 10^{-3}$
19	9/22	1107	30	2,100	2,400	No	No	1,000	-85	---	35	27	38	3,298	6,909	$1.62 \times 10^{-3}$
20	9/22	1141	30	2,100	2,400	No	Yes	1,000	-85	not meas.	35	5	1	65	145	$3.39 \times 10^{-3}$

\*Six-decibel attenuators were inserted at the receiver inputs on Runs 3, 49, 50, 51, 55, and 57.

Table V  
Test Data Log (Continued)

Run No.	Date	Start Time	Run Length		Bit Rate	INT	DIV	P <sub>T</sub>	Median Signal Level		Median S/N	C BLOCKS	E BLOCKS	Symbol Errors	Bit Errors	BER
			Min.	Msgs.					Rev #1	Rev #3						
22	10/5	1212	30	1,050	2,400	Yes	Yes	1,000	-90	not meas.	36	42	0	95	227	$1.06 \times 10^{-4}$
23	10/5	1248	10	350	2,400	Yes	No	1,000	-85	---	36	101	0	224	305	$4.28 \times 10^{-4}$
24	10/5	1301	10	350	2,400	Yes	No	1,000	-84	---	34	100	0	223	312	$4.38 \times 10^{-4}$
25	10/5	1316	10	350	2,400	Yes	No	600	-87	---	32	120	0	352	553	$7.75 \times 10^{-4}$
27	10/5	1343	10	350	2,400	Yes	No	400	-91	---	30	140	0	600	959	$1.35 \times 10^{-3}$
28	10/5	1357	10	350	2,400	Yes	No	400	-86	---	32	100	0	272	683	$9.57 \times 10^{-4}$
29	10/5	1411	10	350	2,400	Yes	No	200	-88	---	32	85	0	269	631	$8.85 \times 10^{-4}$
30	10/5	1426	10	350	2,400	Yes	No	200	-84	---	36	58	0	195	267	$3.74 \times 10^{-4}$
31	10/5	1439	10	350	2,400	Yes	No	200	-89	---	34	88	0	383	562	$7.88 \times 10^{-4}$
32	10/5	1452	10	350	2,400	Yes	No	200	-88	---	31	133	0	796	1,314	$1.84 \times 10^{-3}$
33	10/5	1504	10	350	2,400	Yes	No	200	-90	---	31	132	0	713	1,202	$1.69 \times 10^{-3}$
34	10/5	1517	10	350	2,400	Yes	No	200	-91	---	30	186	0	1,029	1,735	$2.44 \times 10^{-3}$
35	10/5	1529	10	350	2,400	Yes	No	200	-91	---	30	132	0	818	1,177	$1.65 \times 10^{-3}$
36	10/5	1543	10	350	2,400	Yes	No	200	-91	---	32	112	0	617	940	$1.32 \times 10^{-3}$
37	10/5	1556	10	350	2,400	Yes	No	200	-93	---	32	107	0	520	817	$1.15 \times 10^{-3}$
38	10/5	1611	10	350	2,400	Yes	No	100	not meas.	---	not meas.	91	0	610	1,106	$1.55 \times 10^{-3}$
39	10/5	1623	10	350	2,400	Yes	No	100	-89	---	32	125	0	479	705	$9.88 \times 10^{-4}$

Table V  
Test Data Log (Continued)

Run No.	Date	Start Time	Run Length		Bit Rate	INT	DIV	P <sub>T</sub>	Median Signal Level		Median S/N	C BLOCKS	E BLOCKS	Symbol Errors	Bit Errors	BER
			Min.	Msgs.					Rev #1	Rev #3						
40	10/5	1636	10	350	2,400	Yes	No	100	-89	---	32	113	0	482	808	$1.13 \times 10^{-3}$
41	10/5	1648	10	350	2,400	Yes	No	100	-90	---	32	151	0	716	1,173	$1.66 \times 10^{-3}$
42	10/6	0926	10	350	2,400	Yes	No	200	-90	---	37	12	0	41	47	$6.6 \times 10^{-5}$
43	10/6	0940	10	350	2,400	Yes	No	100	-85	---	36	28	0	231	272	$3.82 \times 10^{-4}$
44	10/6	0953	30	1,050	2,400	Yes	No	100	-85	---	37	57	9	1,211	2,420	$1.13 \times 10^{-3}$
49*	10/6	1357	10	350	2,400	Yes	No	600	-88	---	32	29	1	300	457	$6.41 \times 10^{-4}$
50*	10/6	1707	10	350	2,400	Yes	No	600	not meas.	---	33	28	4	525	688	$9.65 \times 10^{-4}$
51*	10/7	0846	10	350	2,400	Yes	No	600	-92	---	31	48	30	1,936	3,716	$5.20 \times 10^{-3}$
52	10/7	0859	10	350	2,400	Yes	No	600	-88	---	37	53	4	592	964	$1.35 \times 10^{-3}$
54	10/7	1125	30	2,100	2,400	No	No	600	-90	---	28	55	5	866	1,195	$2.79 \times 10^{-3}$
55*	10/7	1203	30	2,100	2,400	No	No	600	-89	---	30	123	127	13,124	24,227	$5.69 \times 10^{-3}$
57*	10/7	1351	30	525	1,200	Yes	No	600	-89	---	28	131	0	591	888	$8.28 \times 10^{-3}$

\*Six-decibel attenuators were inserted at the receiver inputs on Runs 3, 49, 50, 51, 55, and 57.

8. DIV - "Yes" indicates dual diversity reception at East Island; "No" indicates non-diversity reception at East Island. \*
9. P<sub>T</sub> - Transmitted power in watts from Grand Turk Island.†
10. Median Signal Level - Median signal level in decibels at receiver inputs as computed from SLVT counter readings. On non-diversity runs, only receiver number 1 was used.
11. Median S/N - Median signal-to-noise ratio as computed from SLVT counter readings.
12. C BLOCKS - The number of 255 symbol messages which were received with errors in them that were subsequently corrected by the decoder.
13. E BLOCKS - The number of 255 symbol messages which were uncorrectable because they contained more than 32 symbol errors.
14. Symbol Errors - The total number of erroneous symbols (before correction) received during the entire run.
15. Bit Errors - The total number of erroneous bits (before correction) received during the entire run.
16. BER - Bit Error Rate, i. e. , the ratio of the number of erroneous bits received during the run to the total bits received.

Tables VI and VII show the number of message and symbol errors before and after correction for interleaved and non-interleaved runs, respectively. The figures at the bottom of the tables show the totals for the entire test series. It is of interest to note in Table VI that the data

---

\*Dual diversity reception was employed at Grand Turk Island for all runs.

† Transmit power from East Island was 5 kilowatts for all runs.

Table VI

Message and Symbol Errors Before and After Correction: Interleaved Runs

Run No.	Total Messages in Run	Message Errors		Symbol Errors	
		Pre-Corr.	Post-Corr.	Pre-Corr.	Post-Corr.
9	1,050	99	10	1,325	500
10	525	137	0	857	0
11	525	94	0	338	0
13	1,050	85	0	210	0
14	1,050	91	0	432	0
15	1,050	57	0	459	0
16	1,050	99	4	1,338	186
17	1,050	84	8	1,376	592
18	1,050	86	28	2,252	1,433
22	1,050	42	0	95	0
23	350	101	0	224	0
24	350	100	0	223	0
25	350	120	0	352	0
27	350	140	0	600	0
28	350	100	0	272	0
29	350	85	0	269	0
30	350	58	0	195	0
31	350	88	0	383	0
32	350	133	0	796	0
33	350	132	0	713	0
34	350	186	0	1,029	0
35	350	132	0	818	0
36	350	112	0	617	0
37	350	107	0	520	0
38	350	91	0	610	0

Table VI (Continued)

Message and Symbol Errors Before and After Correction: Interleaved Runs

Run No.	Total Messages in Run	Message Errors		Symbol Errors	
		Pre-Corr.	Post-Corr.	Pre-Corr.	Post-Corr.
39	350	125	0	479	0
40	350	113	0	482	0
41	350	151	0	716	0
42	350	12	0	41	0
43	350	28	0	231	0
44	1,050	66	9	1,211	763
49	350	30	1	300	34
50	350	32	4	525	200
51	350	78	30	1,936	1,358
52	350	57	4	592	202
57	525	131	0	591	0
<b>TOTALS</b>	<b>19,425</b>	<b>3,382</b>	<b>98</b>	<b>23,407</b>	<b>5,268</b>

Table VII

Message and Symbol Errors Before and After Correction: Non-Interleaved Runs

Run No.	Total Messages in Run	Message Errors		Symbol Errors	
		Pre-Corr.	Post-Corr.	Pre-Corr.	Post-Corr.
3	2,100	85	26	2,765	2,350
4	2,100	71	6	846	256
7	2,100	3	0	3	0
8	2,100	23	1	166	52
19	2,100	65	38	3,298	2,793
20	2,100	6	1	65	45
54	2,100	60	5	866	368
55	2,100	250	127	13,124	11,749
<b>TOTALS</b>	<b>16,800</b>	<b>563</b>	<b>204</b>	<b>21,133</b>	<b>17,613</b>

shown for runs 22 through 41, inclusive, represent the results of the 3-1/2 hours of testing on 5 October 1965 when the channel manifested the rapid fading discussed earlier. A total of 2,116 message errors, 9,393 symbol errors, and 15,476 bit errors occurred before correction during this period. All errors were corrected without exception. The average bit error rate before correction for the 3-1/2-hour period was  $1.14 \times 10^{-3}$ .

Figures 7 and 8 show symbol error rates before and after correction for interleaved and non-interleaved operation. Each point is based on data from 350 successive messages or  $7.14 \times 10^5$  bits. Points corresponding to perfect runs in which all errors were corrected are shown at the top of Figures 7 and 8. It can be seen from these figures that the code tends to provide either perfect correction or relatively low improvement in average symbol error rate. This results primarily from the high incidence of long error bursts in the degraded channel. When they occurred, long error bursts caused large numbers of symbol errors to be concentrated in the uncorrectable messages, which resulted in a low improvement in average symbol error rates. The effectiveness of the code is perhaps best demonstrated by the ratio of perfect runs to total runs. For non-interleaved runs, there was a total of 40 samples of which only 12 resulted in perfect correction. For interleaved runs, there was a total of 54 samples of which 41 resulted in perfect correction.

Figure 9 is a curve of the cumulative distribution of symbol errors in messages having errors, i. e., the percentage of erroneous messages having 1 symbol error, 2 or less, 3 or less, and so on up to 32. The significance of the number 32, of course, is that all messages with over 32 errors are uncorrectable. Curve A, based on data collected during the transmission of 16,800 messages, shows the distribution for non-interleaved operation. It can be seen that only 64 percent of the non-interleaved messages were corrected. Based on data from 19,425 messages, Curve B shows the effect of interleaving. The distribution is seen to be concentrated more heavily toward the low end; thus, correction is provided for 97 percent of all messages with errors.

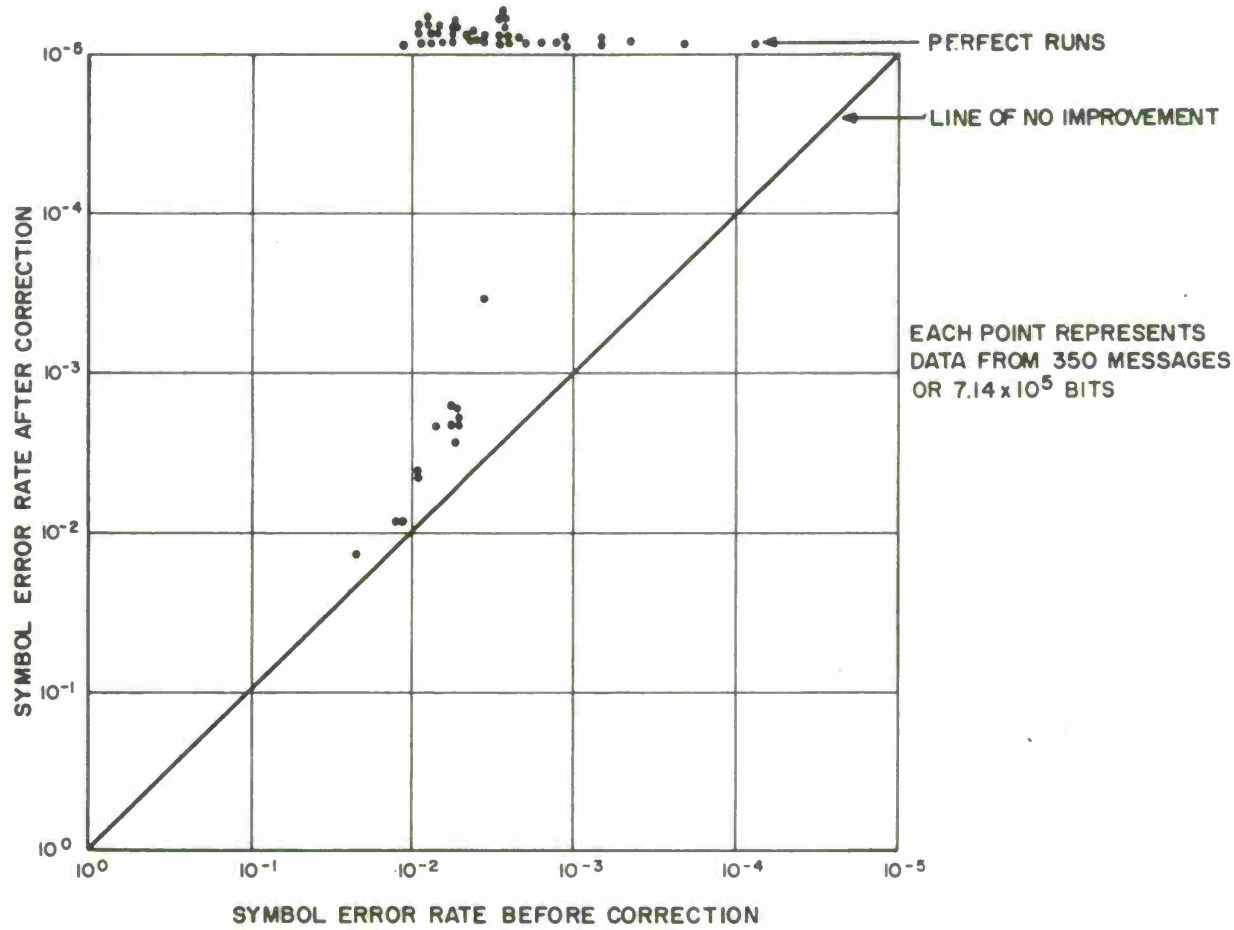

FIG. 4.4  
SER BEFORE AND AFTER CORRECTION  
INTERLEAVED RUNS

Figure 7. Ser Before and After Correction: Interleaved Runs



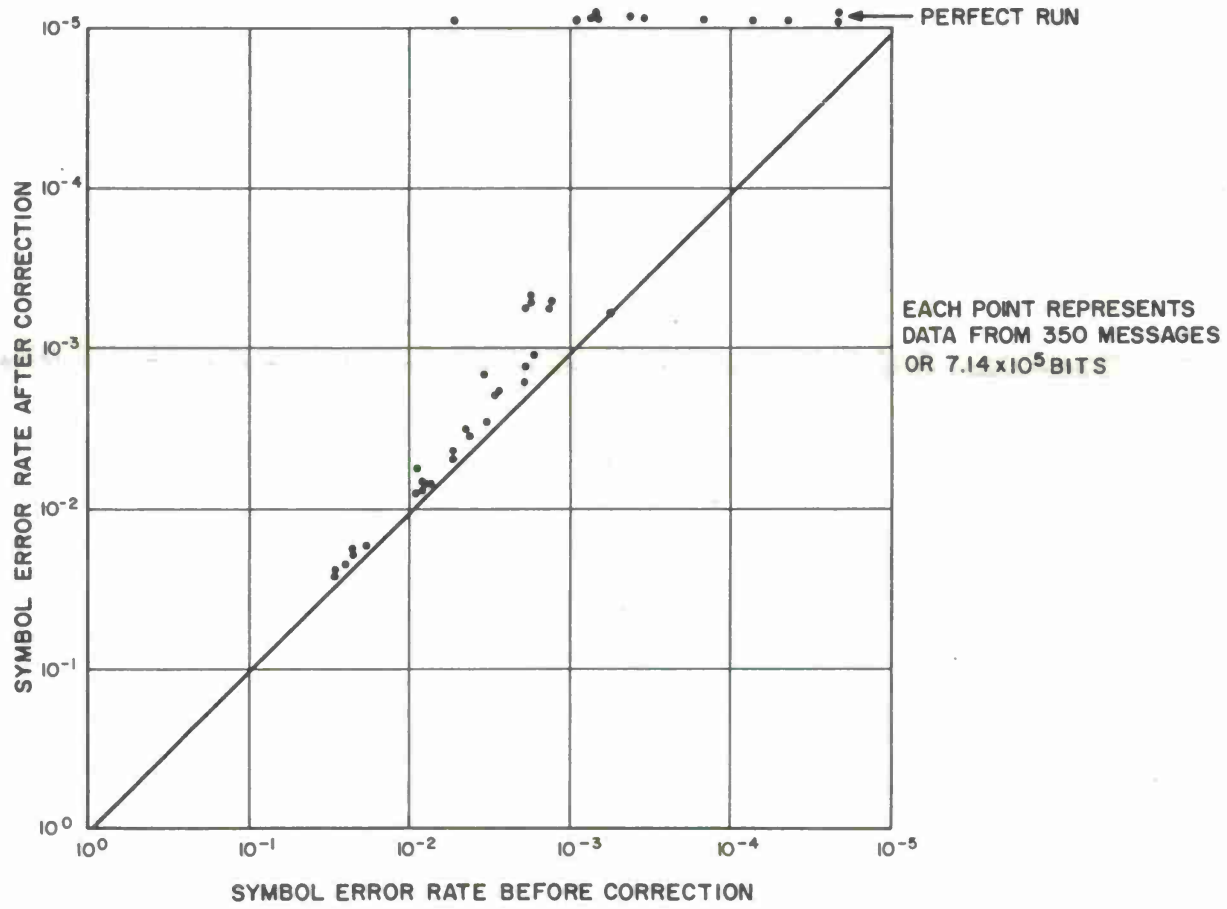

Figure 8. Ser Before and After Correction: Non-Interleaved Runs

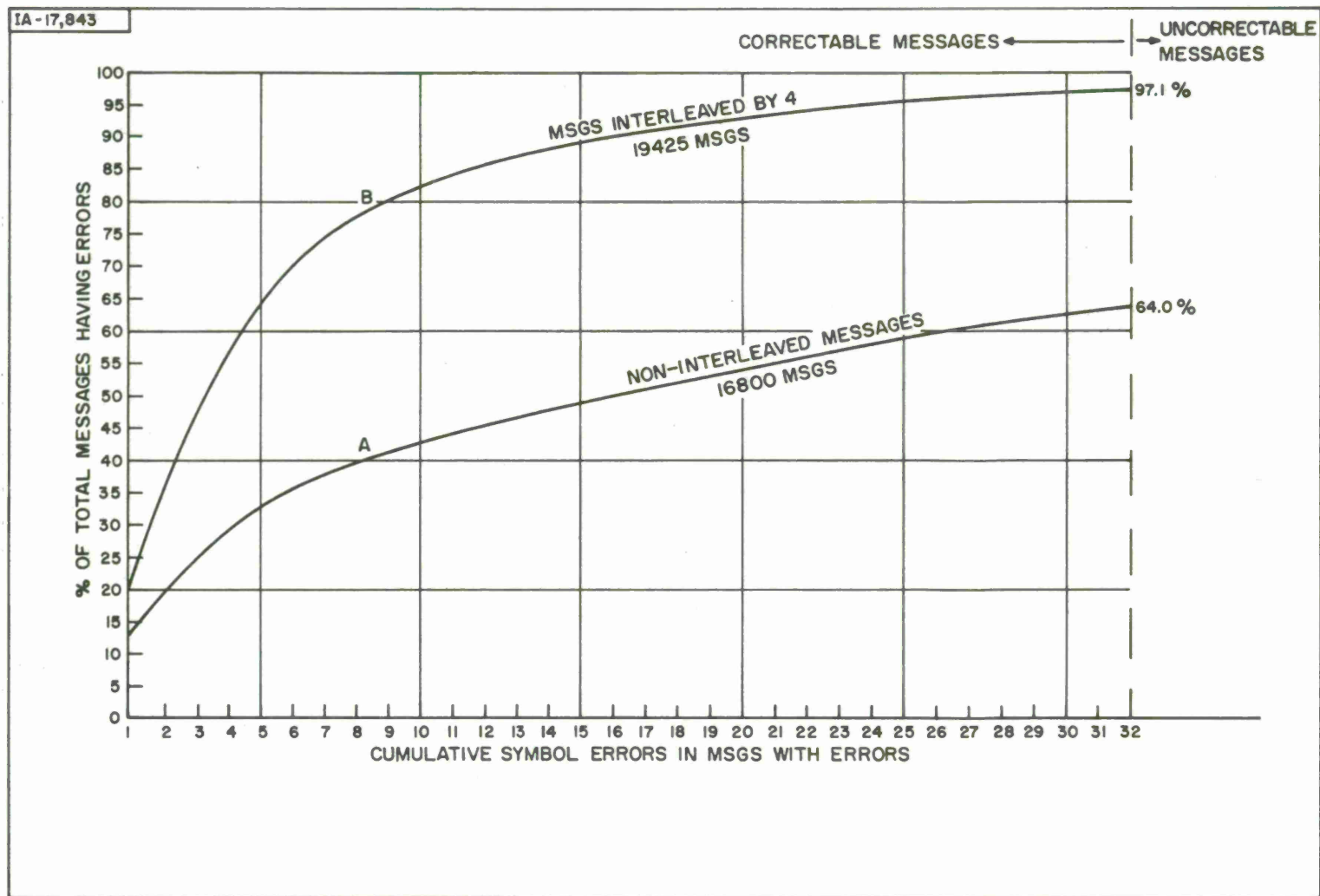

Figure 9. Cumulative Distribution of Symbol Errors in Messages Having Errors

It is of interest to consider how much additional improvement might have been experienced with a greater amount of interleaving. The addition of a standard 4,096-word memory module to the present prototype equipment, for example, would enable interleaving of 16 of the 255 symbol messages. Interleaving by 16 would enable correction of a single error burst of up to 512 symbols in a span of 4,080 symbols. Even more correction could be attained by reducing the information rate of the code. For example, if the message length were reduced to 128 symbols while maintaining 32 symbol correction, the resulting information rate would be reduced to 0.5 instead of the present value of 0.75. It would be possible to interleave 32 of the shorter messages in a 4,096 word memory, thereby enabling correction of a burst of up to 1,024 symbols in a span of 4,096 symbols. At 2400 bits per second, a sustained error burst of 1024 eight-bit symbols would have a duration of 3.4 seconds.

The probable performance of the code with increased interleaving can be estimated from Table VIII. To obtain the data for this table, the message-by-message error printouts (see Table VI) were grouped two lines at a time to represent 16 successive messages. Symbol errors were totaled for each span. The totals thus obtained are shown in Table VIII for those cases where 400 or more symbol errors occurred. The table is ordered by increasing error counts.

The first three columns in Table VIII show the run number, total symbol errors experienced, and the total duration of these errors at 2400 bits per second. The column marked A shows the average number of symbol errors per message which would have occurred if interleaving of 16 of the 255 symbol messages had been employed. Column B shows the same average for interleaving of 32 of the 128 symbol messages. The figures shown in columns A and B are averages, and some variation from these values would, of course, be experienced in individual messages of an interleaved group. Data from the interleaved runs of this test series, however, showed this variation to be small.

Table VIII

Occurrences of Symbol Error Counts > 400 for 16-Message Groupings

Run No.	Total Symbol Errors	Duration in Seconds	Average Symbol Error per Message	
			A	B
55	425	1.42	26.6	13.3
17	435	1.45	27.2	13.6
55	444	1.48	27.8	13.9
55	483	1.61	30.2	15.1
55	502	1.67	31.4	15.7
44	578	1.93	36.1	18.1
55	603	2.01	37.7	18.8
55	727	2.42	45.4	22.7

It may be concluded from Table VIII that if 16 symbol interleaving had been employed most, if not all, errors experienced during test series would probably have been corrected except for those represented by the last five entries in the table. With 32 message interleaving and at rate 0.5, it is very probable that all errors experienced during the entire test series would have been corrected without exception.

#### ERROR DETECTION

The error-detection capability of the code used in the 950 Coder/Decoder is quite powerful. For the code parameters used during the test, the probability that an uncorrectable message will not be detected is less than 1 in  $10^{30}$ .

During the test which includes both interleaved and non-interleaved operation, a total of 302 messages were received with more than 32 symbol errors in them. These were all detected by the decoder as uncorrectable messages because of excessive errors.

## ABORTED RUNS

A total of 58 test runs were initiated during the test series. Of these, 14 runs were aborted because of various equipment and procedural difficulties experienced during the run.

The principal cause for aborted runs was loss of synchronization after initial synchronization had been established and the test run was in progress. In most cases, the exact cause of the sync loss could not be determined. An examination of data in the computer indicated the loss of sync resulted from the "dropping" of a clock pulse. It is not known, however, if this occurred in the AN/GSC-4 modem or in the 950 Coder/Decoder.

During one period of equipment checkout, back-to-back tests were made with the transmitting AN/GSC-4 output tied directly to the receiving AN/GSC-4 input; thus, the radio link was bypassed. Several instances of sync loss occurred. The tests were then repeated using the 950 Coder/Decoders tied back-to-back directly with the AN/GSC-4's out of the loop. On this test, no sync loss occurred. This test indicates probable trouble either in the AN/GSC-4 modem, or in the PDP-8 to AN/GSC-4 interface. This and other tests are not conclusive, however, and the exact cause of the sync difficulties remains unknown.

A list of the aborted runs and their causes is shown below.

<u>Run No.</u>	<u>Cause of Failure</u>
1, 2, 21, 26, 45 47, 48, 53, 58	Sync loss.
5 and 6	Faulty circuit breaker at Grand Turk Island which caused intermittent disconnect of one of the two receivers in use. Runs were completed, but data were considered inadmissible because of the malfunctioning of the equipment.
12	ASR-33 Teletype inadvertently left off for first 39 messages; thereby part of the test data was lost.

<u>Run No.</u>	<u>Cause of Failure</u>
46	Unexplained interruption in radio-frequency signal from Grand Turk Island.
56	Sudden loss of program in PDP-8 computer. A circuit breaker opened simultaneously in an adjacent power line indicating a possible power transient as the cause of program loss.

#### DISTRIBUTION OF BIT ERRORS IN ERROR SYMBOLS

Figure 10 shows the distribution of bit errors in symbol errors. As explained in Section III, these data were available only in runs 19, 20, 54, and 55. All four of these runs were half-hour runs at 2400 bits per second; these data, therefore, are based on a total sample of 2-hour operation at 2400 bits per second. The table on the right of Figure 10 shows the total number of occurrences of symbol errors with 1 to 8 bits in error. The curve on Figure 10 presents the same information on a percentage basis, i. e., the percent of error symbols having 1 bit in error, 2 bits in error, . . . 8 bits in error.

There was a total of 14,971 symbol errors and 29,000 bit errors in the four runs from which these data were collected. Therefore, the average number of bit errors per symbol error for the four runs was 1.96.

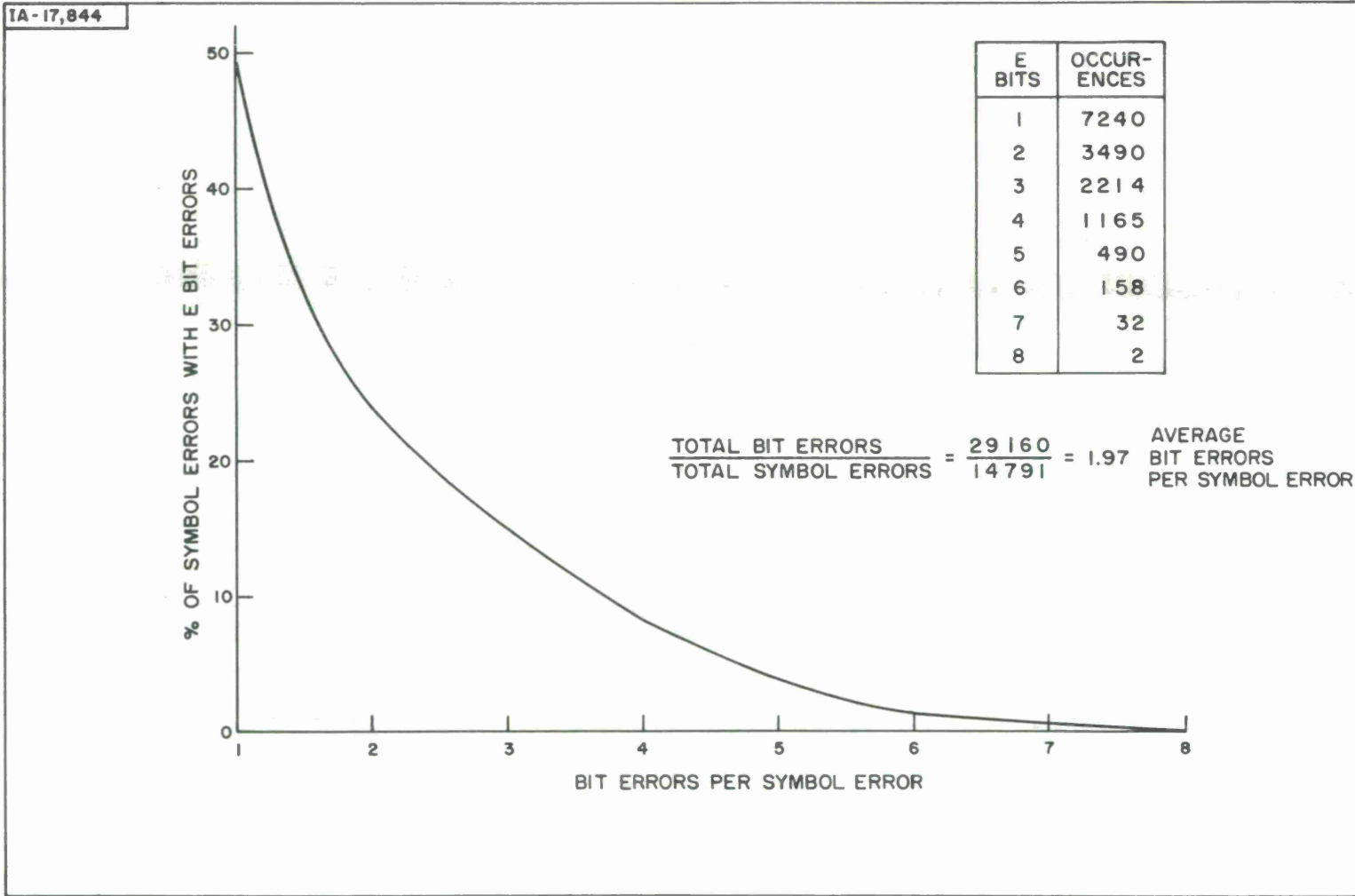

Figure 10. Distribution of Bit Errors in Symbol Errors

## SECTION V

### CONCLUSIONS AND FUTURE PLANS

The test series demonstrated the feasibility and practicability of the prototype system for use in the field. The equipment was successfully interfaced to an operational system and performed the job it was designed for: that is, it corrected all messages having 32 or less symbol errors in a block of 255 symbols, and it detected all messages having more than 32 symbol errors as being uncorrectable because of excessive errors.

For the non-interleaved runs, the percentage of uncorrectable messages was much higher than initially expected. This is attributed to the large number of long fades experienced on the artificially degraded channel. It is felt that the performance of the system would have been considerably improved if the tests had been conducted on a normally configured communications link during a period of normally poor signal propagation. This premise is reinforced by the superior performance of the equipment during the tests on 5 October when the fade characteristics of the link more closely approximated those typical of tropospheric scatter circuits during periods of poor signal propagation.

The technique of interleaving was found to be highly effective in improving the ability of the equipment to correct errors in the presence of long error bursts. The amount of interleaving incorporated during the tests was limited by memory availability in the present prototype and our ability to reprogram the system under field conditions. From an examination of the detailed test printouts, it appears that considerable improvement could have been experienced by a greater amount of interleaving. The data presented in Table VIII indicate that 100-percent correction would probably have been achieved for the entire test series if 32 message interleaving and 50-percent redundancy had been employed. Close to 100-percent correction would probably have been attained with 16 message interleaving and 25-percent



redundancy. This projection is particularly impressive in view of the unfavorable fade characteristics experienced on the intentionally degraded channel.

The error-detection capability of the equipment was found to be excellent. All uncorrectable messages were detected without exception. Thus, the 950 Coder/Decoder could be very effective in an ARQ application, where repeat requests are sent back to the transmitter for uncorrectable messages. It is felt, however, that with the incorporation of added interleaving, the high error-correction capability of the equipment would obviate the need for ARQ systems.

There were several instances of sync loss during the test series. It could not be determined conclusively during the test whether the trouble originated in the modem or in the 950 equipment. This problem will be investigated, and corrective measures, if necessary, will be incorporated in the 950 equipment. Relatively simple hardware modifications are possible within the 950 equipment which will compensate for "dropped" timing pulses even if the trouble originates in the modem. In addition, it is possible to include a short sync pattern in each message which would enable automatic sync recovery by programming methods if sync loss occurs during a transmission.

The plans for the future are to study in greater detail the potential benefits of interleaving and the trade-offs between various methods by which interleaving may be incorporated into the prototype system. The possible techniques will be evaluated in the laboratory against live error data which have been recorded by MITRE on various high-frequency channels. If deemed necessary, measures to reduce the possibility of sync loss will also be incorporated. Subsequent to incorporation of measures for improved interleaving and possible measures for sync protection, one or more field tests will be conducted on live high frequency and/or tropospheric scatter communication circuits to demonstrate performance of the improved system.

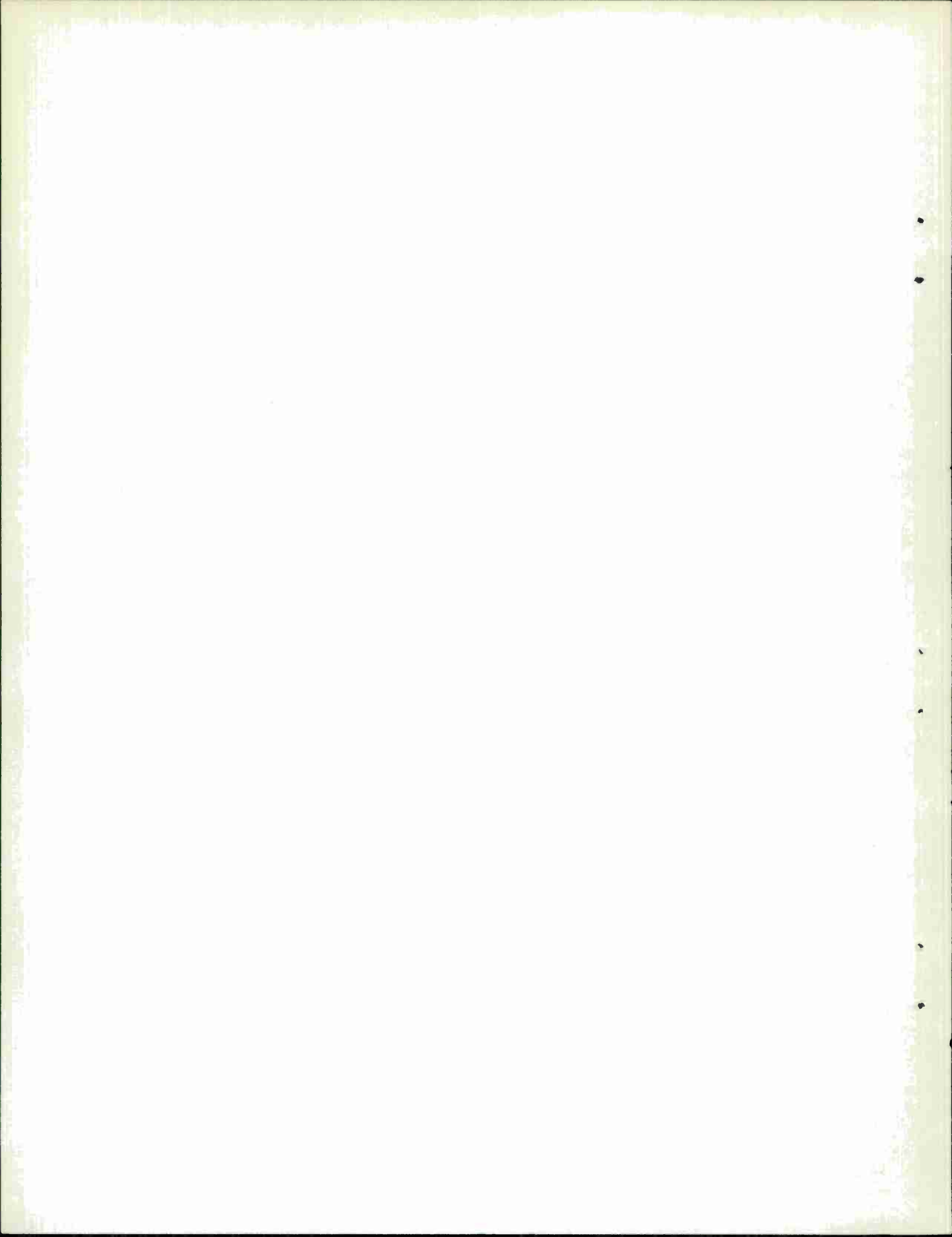

## DOCUMENT CONTROL DATA - R&amp;D

*(Security classification of title, body of abstract and indexing annotation must be entered when the overall report is classified)*

1. ORIGINATING ACTIVITY (Corporate author) The MITRE Corporation Bedford, Massachusetts		2a. REPORT SECURITY CLASSIFICATION Unclassified	
		2b. GROUP	
3. REPORT TITLE Field Test of The MITRE 950 Coder/Decoder			
4. DESCRIPTIVE NOTES (Type of report and inclusive dates) N/A			
5. AUTHOR(S) (Last name, first name, initial) Terzian, John			
6. REPORT DATE July 1966	7a. TOTAL NO. OF PAGES 45	7b. NO. OF REFS 2	
8a. CONTRACT OR GRANT NO. AF19(628)-5165	9a. ORIGINATOR'S REPORT NUMBER(S) ESD-TR-66-101		
b. PROJECT NO. 7560	9b. OTHER REPORT NO(S) (Any other numbers that may be assigned this report) MTR-134		
c.			
d.			
10. AVAILABILITY/LIMITATION NOTICES Distribution of this document is unlimited.			
11. SUPPLEMENTARY NOTES		12. SPONSORING MILITARY ACTIVITY Deputy for Communications Systems Directorate of Communications Development Electronic Systems Division L. G. Hanscom Field, Bedford, Massachusetts	
13. ABSTRACT  This document describes the results of a field test held in September and October 1965 on a new error correction/detection equipment developed under MITRE Independent Research. Sponsored by ESD Deputy for Communications, the tests were held in the Caribbean area on a tropospheric scatter communications link made available by the Rome Air Development Center. The tests demonstrated the ability of the equipment to operate successfully in a field environment. A technique of interleaving messages was introduced during the test series and was found to be highly effective in enhancing error correction, particularly in the presence of long error bursts.			

14.	KEY WORDS	LINK A		LINK B		LINK C	
		ROLE	WT	ROLE	WT	ROLE	WT
		Error Correction and Detection Digital Communications					

**INSTRUCTIONS**

1. **ORIGINATING ACTIVITY:** Enter the name and address of the contractor, subcontractor, grantee, Department of Defense activity or other organization (*corporate author*) issuing the report.
- 2a. **REPORT SECURITY CLASSIFICATION:** Enter the overall security classification of the report. Indicate whether "Restricted Data" is included. Marking is to be in accordance with appropriate security regulations.
- 2b. **GROUP:** Automatic downgrading is specified in DoD Directive 5200.10 and Armed Forces Industrial Manual. Enter the group number. Also, when applicable, show that optional markings have been used for Group 3 and Group 4 as authorized.
3. **REPORT TITLE:** Enter the complete report title in all capital letters. Titles in all cases should be unclassified. If a meaningful title cannot be selected without classification, show title classification in all capitals in parenthesis immediately following the title.
4. **DESCRIPTIVE NOTES:** If appropriate, enter the type of report, e.g., interim, progress, summary, annual, or final. Give the inclusive dates when a specific reporting period is covered.
5. **AUTHOR(S):** Enter the name(s) of author(s) as shown on or in the report. Enter last name, first name, middle initial. If military, show rank and branch of service. The name of the principal author is an absolute minimum requirement.
6. **REPORT DATE:** Enter the date of the report as day, month, year; or month, year. If more than one date appears on the report, use date of publication.
- 7a. **TOTAL NUMBER OF PAGES:** The total page count should follow normal pagination procedures, i.e., enter the number of pages containing information.
- 7b. **NUMBER OF REFERENCES:** Enter the total number of references cited in the report.
- 8a. **CONTRACT OR GRANT NUMBER:** If appropriate, enter the applicable number of the contract or grant under which the report was written.
- 8b, 8c, & 8d. **PROJECT NUMBER:** Enter the appropriate military department identification, such as project number, subproject number, system numbers, task number, etc.
- 9a. **ORIGINATOR'S REPORT NUMBER(S):** Enter the official report number by which the document will be identified and controlled by the originating activity. This number must be unique to this report.
- 9b. **OTHER REPORT NUMBER(S):** If the report has been assigned any other report numbers (*either by the originator or by the sponsor*), also enter this number(s).
10. **AVAILABILITY/LIMITATION NOTICES:** Enter any limitations on further dissemination of the report, other than those

imposed by security classification, using standard statements such as:

- (1) "Qualified requesters may obtain copies of this report from DDC."
- (2) "Foreign announcement and dissemination of this report by DDC is not authorized."
- (3) "U. S. Government agencies may obtain copies of this report directly from DDC. Other qualified DDC users shall request through \_\_\_\_\_."
- (4) "U. S. military agencies may obtain copies of this report directly from DDC. Other qualified users shall request through \_\_\_\_\_."
- (5) "All distribution of this report is controlled. Qualified DDC users shall request through \_\_\_\_\_."

If the report has been furnished to the Office of Technical Services, Department of Commerce, for sale to the public, indicate this fact and enter the price, if known.

11. **SUPPLEMENTARY NOTES:** Use for additional explanatory notes.
12. **SPONSORING MILITARY ACTIVITY:** Enter the name of the departmental project office or laboratory sponsoring (*paying for*) the research and development. Include address.
13. **ABSTRACT:** Enter an abstract giving a brief and factual summary of the document indicative of the report, even though it may also appear elsewhere in the body of the technical report. If additional space is required, a continuation sheet shall be attached.

It is highly desirable that the abstract of classified reports be unclassified. Each paragraph of the abstract shall end with an indication of the military security classification of the information in the paragraph, represented as (TS), (S), (C), or (U).

There is no limitation on the length of the abstract. However, the suggested length is from 150 to 225 words.

14. **KEY WORDS:** Key words are technically meaningful terms or short phrases that characterize a report and may be used as index entries for cataloging the report. Key words must be selected so that no security classification is required. Identifiers, such as equipment model designation, trade name, military project code name, geographic location, may be used as key words but will be followed by an indication of technical context. The assignment of links, rules, and weights is optional.

