

AD 634681

GARABEDIAN and JOHNSON

CLEARINGHOUSE FOR FEDERAL SCIENTIFIC AND TECHNICAL INFORMATION			
Hardcopy	Microfiche	9	72
\$ 1.00	\$ .50	PP	
ARCHIVE COPY			
PROCESSING COPY			

O

"THE THEORY OF OPERATION OF AN AMMONIA  
BURNING INTERNAL COMBUSTION ENGINE"

CHARLES G. GARABEDIAN and JOHN H. JOHNSON  
HQ, US ARMY TANK-AUTOMOTIVE CENTER  
WARREN, MICHIGAN

JUL 6 1960

INTRODUCTION

Logistics studies of Army operations in World War II and Korea established that approximately 65% of the total tonnage required for support of combat operations consisted of fuels and lubricants. To compound this already heavy logistical burden, future Army concepts envision increased mechanization and greater emphasis on mobility and dispersion. Faced with these problems, the Army searched for other materials and devices for vehicle propulsion. Nuclear energy seemed the apparent answer.

Analysis proved that direct use of nuclear energy presented serious problems of application to vehicles. Attention was then turned to other potential applications of a nuclear energy power source. The Army in a cooperative research and development effort established the practicality of mobile nuclear reactors as a source of energy in the field. These studies indicated three possible approaches wherein nuclear energy could be used with direct or indirect energy conversion devices or as the power source could provide the energy to synthesize chemical fuels. Further studies indicated that to realize early payoff the latter approach held the most promise. It was decided that a nuclear power source could provide the energy to synthesize chemical fuels with air and water as the on-site raw materials. This concept to provide on-site manufacturing of fuels is referred to as the Mobile Energy Depot (MED). Materials showing the greatest potential were hydrogen, ammonia, hydrazine and hydrogen

GARABEDIAN and JOHNSON

peroxide. Factors concerned with physical and chemical properties, handling, storage and dispensing of the four fuels led to the choice of ammonia as the fuel with the greatest potential.

As part of the overall feasibility study of the Mobile Energy Depot concept, the U.S. Army Tank-Automotive Center was assigned the task to investigate the use of anhydrous ammonia as an alternate fuel for reciprocating engines in military automotive equipment.

Two basic approaches are presented for achieving combustion of ammonia in internal combustion engines. The first approach is one of integrating the ammonia combustion capability into the research and development of engines for the 1975-80 time frame. This approach would have the objective of building a multi-fuel engine which could use MED or commercially produced ammonia. The second approach is one of converting existing engines by the use of modification kits. This approach could be applied to engines in the 1965-70 time frame, and would appear to require the use of ammonia produced commercially since the MED concept has application in the 1980 time frame.

#### PAST WORK

The use of ammonia as a fuel for internal combustion engines has been around at least since the year 1935 (1). A more extensive use of ammonia as a fuel was undertaken on vehicles in Belgium in 1942 (2). In this case ammonia vapor plus coal gas was burned in the engine. More recent data on the MED concept and single cylinder and multi-cylinder research work is presented in Reference (3). In Reference (3) several practical methods for improving engine performance while burning ammonia are described which include increased spark energy, increased compression ratio, engine supercharging, and hydrogen addition to the fuel. This study indicates that satisfactory engine performance can be obtained while burning ammonia.

A more recent paper (4) considers both theory and application of ammonia for spark ignition engines. The results of this work showed that spark timing for maximum

GARABEDIAN and JOHNSON

performance must be advanced slightly for ammonia but sensitivity to spark timing is slightly greater than with hydrocarbons. The theory showed that maximum indicated output using ammonia vapor is about 77% of that with hydrocarbons and specific fuel consumption increases two times. In addition, the data showed a 2½ time increase in specific fuel consumption at maximum economy.

The U. S. Army Fuels and Lubricants Research Laboratory has recently presented data (5) on the compatibility of ammonia and its combustion products with engine materials and lubricants. In addition, a further study of compression ignition engine performance was made to ascertain the ability of ammonia to be pumped in existing injection systems and various means of achieving ammonia combustion were explored.

Several of the general conclusions of this paper were:

1. Compatibility of ammonia and its combustion products with engineering materials and lubricants presents no substantial problem.
2. Ammonia-only combustion requires high compression ratios and temperatures (35:1 compression ratio, 300°F air and coolant).
3. None of the fuel additives investigated significantly lowered the energy level requirement for ammonia ignition.
4. Gases introduced into the intake manifold resulted in ammonia combustion although amounts required were high (10% hydrogen, 15-20% acetylene).

#### PROPERTIES AND COMBUSTION CHARACTERISTICS OF AMMONIA

There are many problems in burning ammonia in Spark-Ignition (SI) and Compression-Ignition (CI) engines. Most of these problems can be related to the properties and combustion characteristics of ammonia. The combustion characteristics that present the largest problems with ammonia are the following:

- (1). Very high autoignition temperature.

GARABEDIAN and Johnson

- (2) Low flame speed.
- (3) Narrow flammability limits.
- (4) High heat of vaporization.

These properties are better illustrated in Table 1 where a direct comparison is made of the properties of hydrogen, diesel, gasoline and ammonia fuels. Fuels with a high autoignition temperature and long delay are good SI engine fuels while those of low autoignition temperatures and short delays are good CI fuels. From Table 1 the high autoignition temperature and the narrow flammability limits point out clearly why ammonia presents many problems in the CI engine. Ammonia further complicates matters in the CI engine with its high latent heat of vaporization which causes very large gas temperature drops at the time of injection. The characteristics of low flame velocity and narrow flammability limits present the main combustion problems in an SI engine although they can be overcome with the proper design.

*insert table!*

**Table 1****COMBUSTION-RELATED PROPERTIES OF AMMONIA**

	HYDROGEN	DIESEL	GASOLINE	AMMONIA
HEAT OF COMBUSTION, BTU/LB (LIQUID)	49,900	18,500	18,900	8,000
STOICHIOMETRIC FUEL/AIR RATIO	0.0292	0.068	0.068	0.1653
THEORETICAL COMBUSTION TEMP, °F (STOICHIOMETRIC REACTANT AT 77°F, 1 ATM)	3750	3750	3700	3100
BOILING POINT (1 ATM), °F	-423	-	-	-28
LATENT HEAT OF VAPORIZATION, BTU/LBM	196	125	125	599
AUTOIGNITION TEMPERATURE, °F	1170	500	800	1200
MINIMUM IGNITION ENERGY, MILLIOULES	0.18	0.3	0.3	9.0
FLAME SPEED, CM/SEC	300	100	100	33
FLAMMABILITY LIMITS % STOICHIOMETRIC FUEL-AIR RATIO	10/713	50/380	50/380	63/138
OCTANE RATING (RESEARCH)	-	55/70	91	130 +
CETANE RATING	-	35/60	10	-7
SPECIFIC GRAVITY @ 60°F	-	.845	.733	.612

(REPRODUCED WITH PERMISSION FROM "AMMONIA PROJECT" CONTINENTAL AVIATION & ENGINEERING CORPORATION)

GARABEDIAN and JOHNSON

THE THEORY OF OPERATION OF AN AMMONIA BURNING SI ENGINE

When burning a stoichiometric mixture of ammonia and air, the following chemical equation holds:

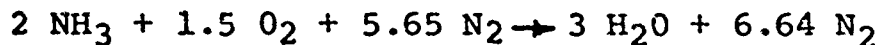

Due to slow flame speed and narrow flammability limits, the complete combustion of ammonia in an SI engine is hard to achieve. The data in Reference (3) strongly suggest that the approach of disassociating the ammonia vapor to achieve approximately 2-3% hydrogen by weight would be a practical way to operate an ammonia burning SI engine. The use of hydrogen to promote the combustion of ammonia is a logical choice because theoretically it could be produced on the vehicle itself by disassociating some of the ammonia fuel in a catalytic disassociator. As shown in Table 1, hydrogen has wide flammability limits, is ignited easily and has a high flame speed. The disassociation of ammonia to nitrogen and hydrogen is controlled by the following equation:

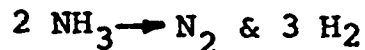

The above equation shows that for each volume of ammonia decomposed, one-half volume will be nitrogen and one and one-half will be hydrogen. In addition, for each per cent by weight of hydrogen, 5.67% by weight of ammonia will have to be decomposed which will result in 4.67% of nitrogen.

The approach to ammonia combustion in an SI engine in this paper is based on the use of hydrogen enrichment. The hydrogen is obtained by passing ammonia through a disassociator. Basically, the disassociator is a shell and tube type heat exchanger which uses a catalyst and engine exhaust energy to partially disassociate ammonia into nitrogen and hydrogen. In order to achieve full power output from a conventional SI engine, a supercharger driven off the engine is required. A schematic of the fuel tank-engine system is shown in Figure 1.

EXPERIMENTAL DATA ON L-141 ENGINE

For initial experimental ammonia combustion studies a 4-cylinder, spark-ignition L-141, 65 HP gasoline military engine was used. Although the data is of a preliminary nature, several of the results are significant.

*insert Fig 1*

The L-141 engine has been set up and performance curves determined for both combat gasoline and ammonia. The system for which the engine is designed was described in the previous paragraph and the schematic of Figure 1. The data presented in Figure 2 is without the disassociator system and is for simulated hydrogen enrichment, and shows various maximum power curves for the L-141 engine. Initially, the engine was run on combat gasoline in the "as received" condition. These data are shown by the solid base-line curve in Figure 2. The L-141 engine was first converted to ammonia operation by changing over to the LPG carburetor and holding all other components fixed. This resulted in the engine being limited to a maximum of 10 horsepower and speeds less than 2,000 rpm.

Next, the disassociator was simulated and the engine was given the optimum amount of hydrogen and best torque spark advance. This resulted in the engine being limited to a maximum of 27.5 horsepower (at 2,000 rpm) and speeds less than 3,200 rpm as shown in Figure 2. The head on the standard L-141 engine was then changed to one that resulted in a 12.6:1 compression ratio (CR). When operating on ammonia vapor alone and a 12.6:1 CR, the engine was limited to 17 horsepower (at 1,850 rpm) and speeds less than 2,300 rpm. Operating with the optimum

# SPARK-IGNITION ENGINE FUEL SYSTEM SCHEMATIC

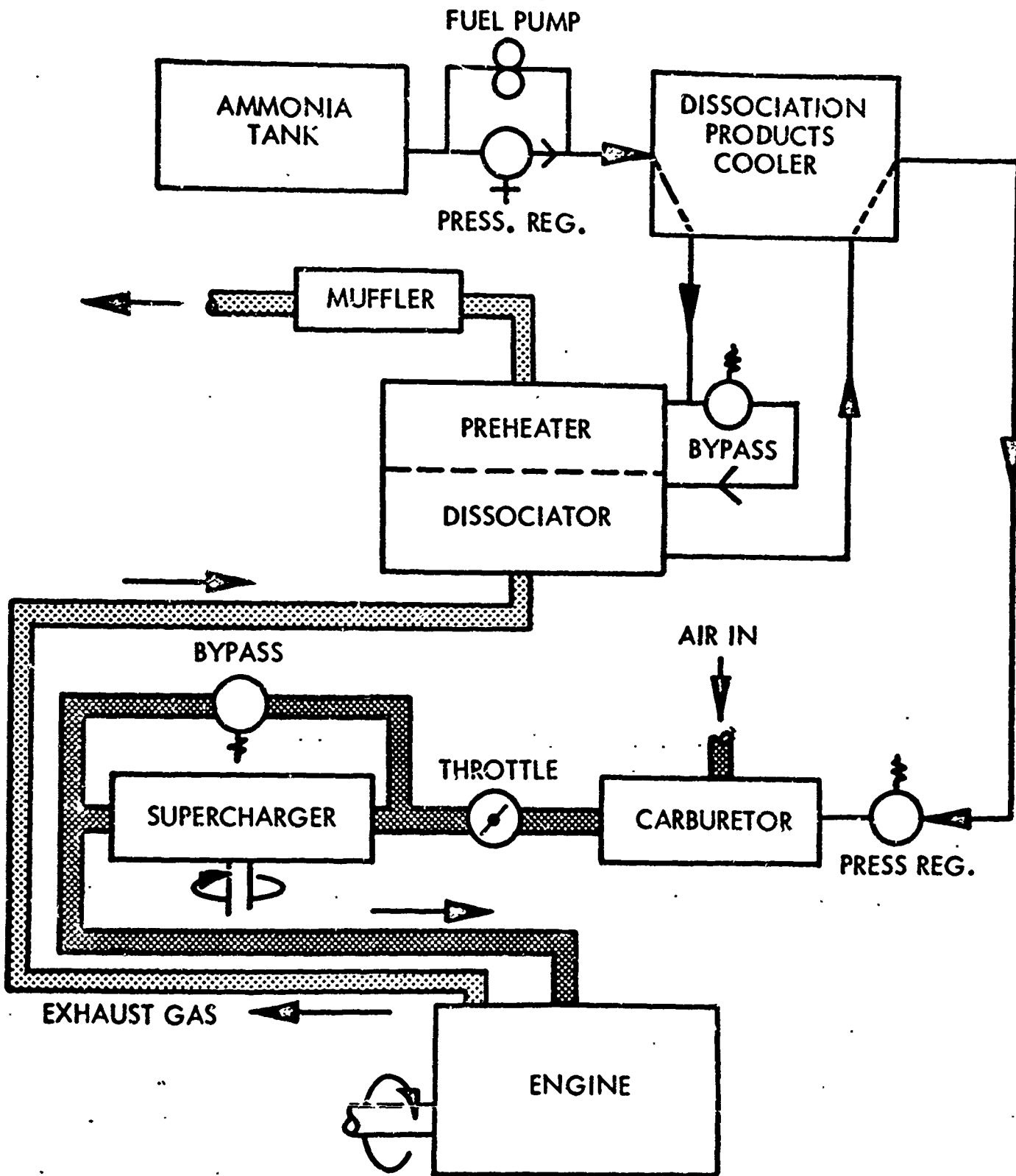

Figure 1.



## COMPARISON OF PERFORMANCE, GASOLINE VS. AMMONIA, FUEL FOR L-141 ENGINE

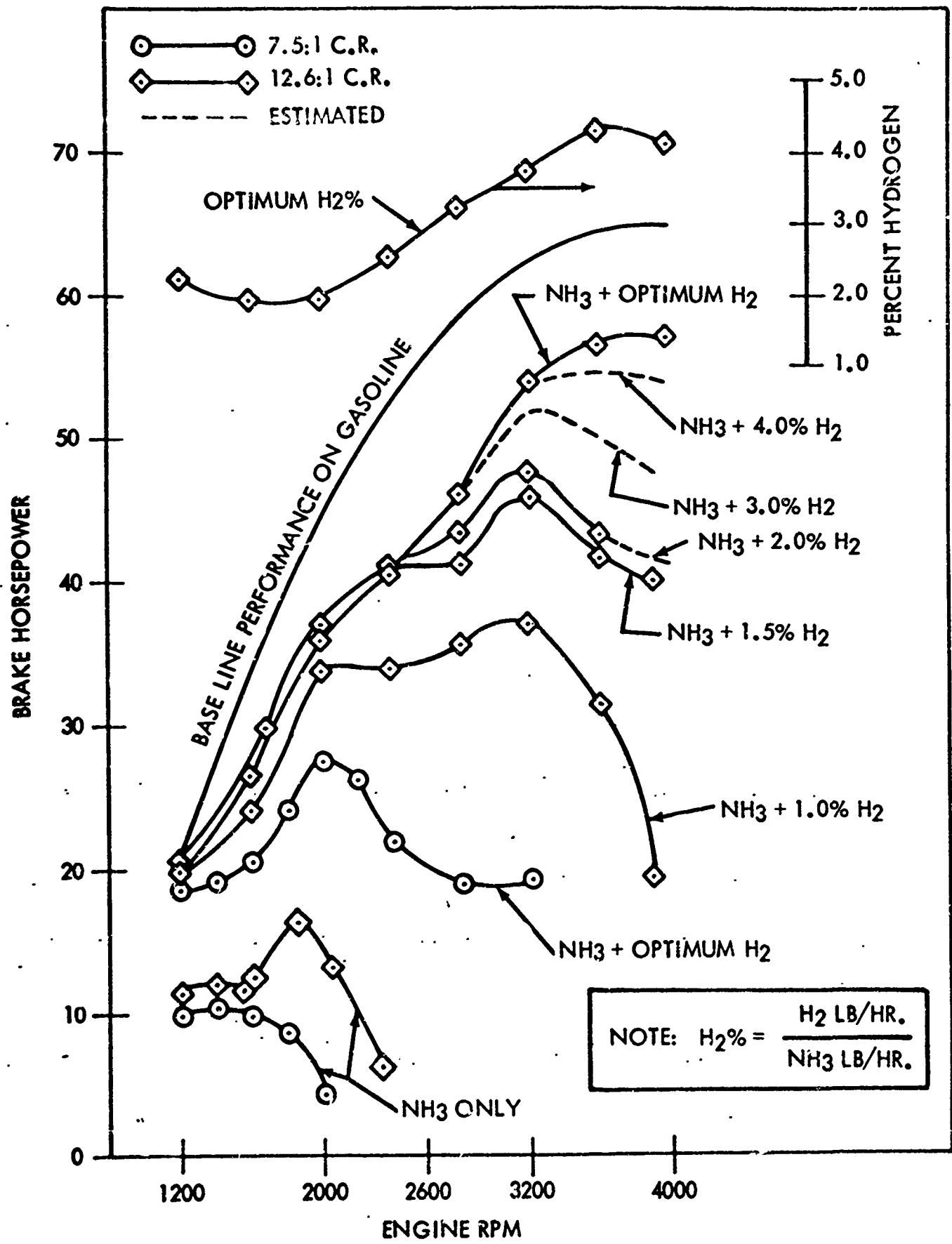

Figure 2.

GARABEDIAN and JOHNSON

hydrogen concentration at the 12.6:1 CR resulted in engine performance up to 4,000 rpm. In addition, power output was above that which is predicted theoretically (Reference 4). Although the power output on ammonia was acceptable, engine operation was still very sensitive to the hydrogen concentration. This can be seen in Figure 2 where 2, 3 and 4% of hydrogen made great differences in output power.

The data on the L-141 engine is very encouraging but will require much more work. Two problem areas that require further investigation are the catalyst used in the disassociator and the problem of having a responsive engine. Preliminary running with a disassociator has shown that the catalyst used, triply-promoted iron, is unacceptable for automotive engine application since it powders from the engine vibrations. The problem of engine response is related to the disassociator system and the high heat of vaporization of ammonia. When a sudden demand for fuel (ammonia) by the engine is made, the increased flow of ammonia apparently cools the system excessively, resulting in reduced hydrogen output. This in turn reduces exhaust temperatures which the disassociator system depends on for the energy to disassociate ammonia. This process is cumulative, resulting in marked reduction in the efficiency of the disassociator system. Work is now in progress to correct these two problem areas.

#### VEHICLE MODIFICATIONS FOR AMMONIA OPERATION

The components required to convert a conventional SI engine to ammonia operation have been briefly discussed in a previous paragraph. In addition to these components, new cylinder head(s), intake manifold(s), exhaust manifold(s), starting aids, cooling system modifications, and minor material changes would be required to convert a gasoline burning SI engine to ammonia capability. Reference (6) presents data for the estimated costs of converting present engines from gasoline burning to ammonia burning. These cost figures showed that the conversions would cost from 50 to 200% of the original costs of the standard engine.

In addition to the engine conversion, a completely new fuel tank is required for ammonia. To determine the size of ammonia fuel tanks for a particular vehicle, the baseline used was to provide for the volume of ammonia fuel equal in heating value to that of the hydrocarbon fuel carried on the standard vehicle. Using the fuel tank capacity of the standard vehicle, and increasing it by

GARABEDIAN and JOHNSON

2.8 times, a basic volume required for ammonia tanks was determined. This 2.8 volume factor for going from hydrocarbon fuels to ammonia is one of the biggest disadvantages of ammonia as a military fuel since engine fuel tank space is such a premium.

The high vapor pressure values of ammonia necessitated pressurized vessel design. Reference (6) goes into greater detail for the design and installation of fuel tanks for eight typical military vehicles. The tank design must consider both engine heat rejection loads and solar radiation loads. A cylindrical tank design was used on all wheeled vehicles studied in Reference (6), in order to take advantage of high strength to weight ratios. In the tracked vehicles (6), because of space limitations, the hydrocarbon fuel tanks were replaced with ammonia fuel tanks of similar configuration and were constructed with flat plate alloy steel. A wall thickness of 0.75 inch was required in the flat plate design for structural integrity to withstand 310 psia pressure for ammonia at the 125° F temperature encountered within the engine compartment. One inch vinyl insulation was used for all tracked-vehicle fuel tanks in Reference (6) to assure that ammonia fuel temperatures did not exceed 125°F. The ammonia fuel tank weights for the wheeled vehicles varied from 2.2 - 2.8 lbm/gallon of capacity and the tracked vehicles varied from 12 - 15 lbm./gallon of capacity (6). Figures 3 and 4 show the ammonia fuel tank installation for the 1/4 ton truck, M151 and the 3/4 ton truck M37B1. These fuel tank installations removed approximately 15% of the available cargo space of these vehicles.

COMPRESSION-IGNITION DATA

Due to the large number of problems of burning ammonia in a compression-ignition (CI) engine and the low probability of success in the 1965-70 time frame, it would be best to convert CI engines to operate as spark-ignition engines for this period. Recently (7) some success has been obtained on a single cylinder CFR engine using early liquid ammonia fuel injection and spark-ignition with a conventional diesel engine. Under these conditions of spark operation, very early fuel injection is required to operate the diesel engine on liquid ammonia since it is hypothesized the fuel charge must have sufficient time before ignition for evaporation and disassociation to take place (7). Further work will be required to prove the feasibility of this approach.

Another interesting approach to ammonia combustion in a CI engine is to introduce ammonia vapor at engine inlet temperature into the intake manifold of the engine

## AMMONIA FUEL TANK INSTALLATION ON 1/4 TON TRUCK, M151

AMMONIA FUEL TANK CAPACITY	50 GAL.
AMMONIA FUEL TANK WEIGHT	140 LBS. (2 TANKS)
AMMONIA FUEL WEIGHT	253 LBS. TOTAL
TOTAL WEIGHT FUEL TANKS PLUS FUEL	393 LBS.

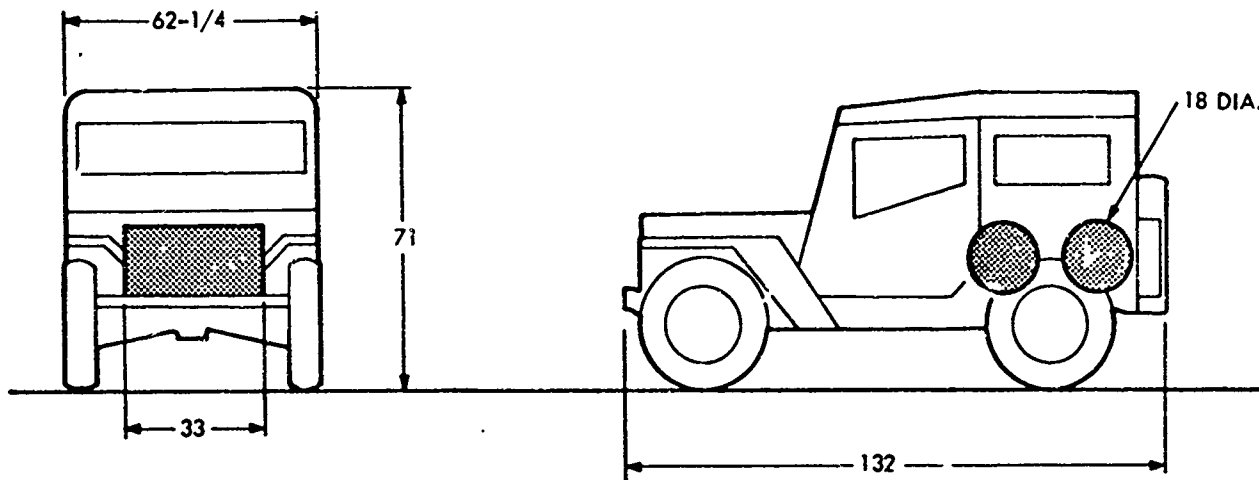

Figure 3.

## AMMONIA FUEL TANK INSTALLATION ON 3/4 TON TRUCK, M37B1

AMMONIA FUEL TANK CAPACITY	67 GAL.
AMMONIA FUEL TANK WEIGHT	160 LBS. (2 TANKS)
AMMONIA FUEL WEIGHT	343 LBS.
TOTAL WEIGHT FUEL TANKS PLUS FUEL	503 LBS.

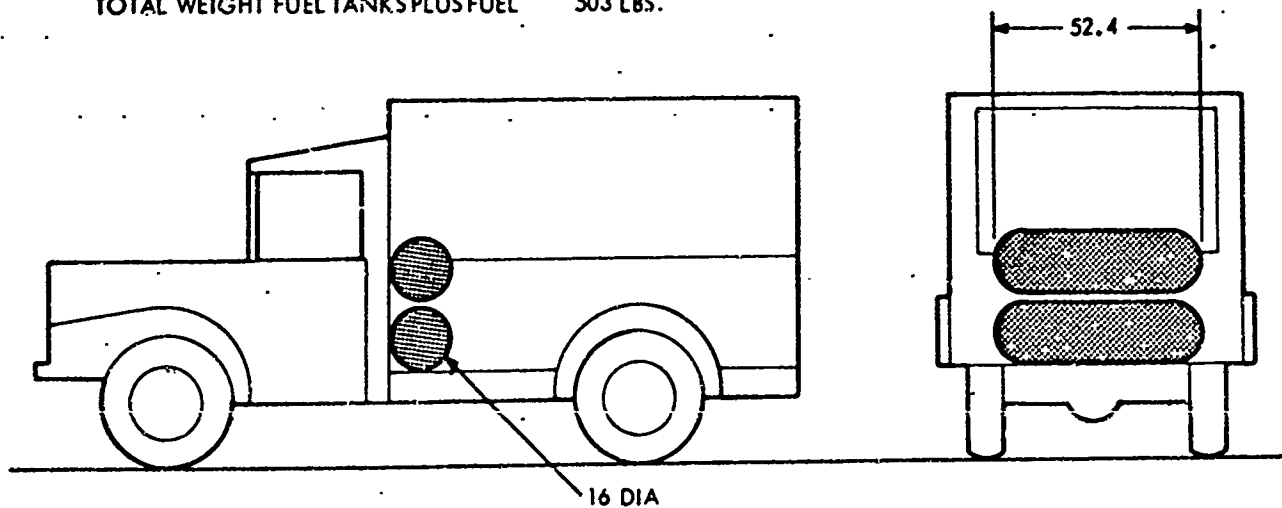

Figure 4.

GARABEDIAN and JOHNSON

followed by a small amount of diesel fuel injected with the conventional fuel injection system as the pilot charge. The above experiment was carried out on the Vee Twin 1790 engine. The amount of diesel fuel was less than 4% of the ammonia vapor by weight. The maximum horsepower curves for operation of the Vee Twin 1790 on diesel fuel only and ammonia vapor plus diesel fuel are shown in Figure 5. It should be noted that the operation on ammonia plus diesel fuel resulted in greater power output than with diesel fuel only. This is caused by better air utilization under these conditions. Part-load data have been taken using this approach and, based on the narrow flammability limits of ammonia, throttling will be required.

This approach looks very good for the CI engine if the use of hydrocarbon fuels is allowed. Converting present engines to this approach would cost nearly the same as for converting them to SI engines. This CI engine concept looks particularly good for future multi-fuel engines.

#### THE CONCEPT OF A HYDROCARBON-AMMONIA BURNING ENGINE

The concept of a reciprocating engine that could burn both ammonia and hydrocarbon fuel may at first seem insurmountable. The use of the Variable Compression Ratio (VCR) piston (8) would lend itself to the design of a multi-fuel engine. The VCR piston is an automatic hydraulically actuated piston that provides a practical method of obtaining a variable compression ratio engine.

The data in Figure 2 show that the performance of the SI ammonia engine is substantially better at the 12.6:1 compression ratio (CR). This CR would be highly objectionable for operation on gasoline. Peak pressures for the 12.6:1 CR with ammonia are of the same order of magnitude as the 7.5:1 CR with gasoline. Hence, a multi-fuel SI engine would be possible using the VCR pistons. In addition to the VCR pistons, means to advance the spark for operating on ammonia would be required. Also both an LPG and a conventional carburetor would be required for metering the two fuels. This approach of building a multi-fuel engine would only be practical if this capability was designed into the engine during the R&D phase. Admittedly, this multi-fuel SI engine would be an expensive engine but it would still be cheaper than what it would cost to convert engines in the present military fleet to ammonia only operation.

For the concept of a CI multi-fuel engine there are several possibilities. If the use of small quantities of

**MAXIMUM POWER DATA COMPARISON, AMMONIA VAPOR  
AND DIESEL PILOT INJECTION VS. DIESEL FUEL ONLY  
FOR V-TWIN 1790 (18.6:1 C. R.)**

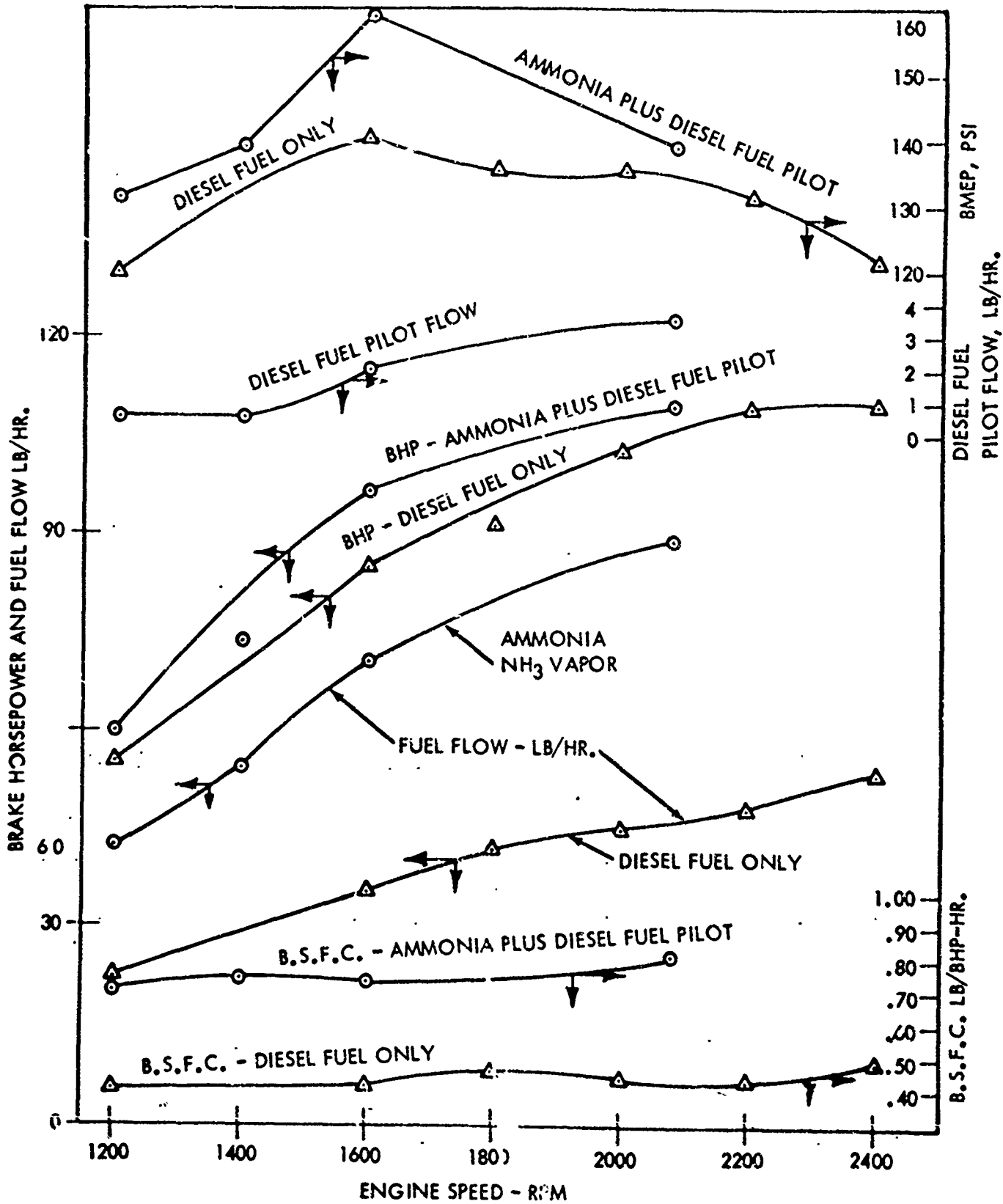

Figure 5

GARABEDIAN and JOHNSON

diesel fuel is permitted, a system such as used for the data of Figure 5 would be a possibility. This approach would require an LPG carburetor to meter the fuel and a preheater to vaporize the liquid ammonia and heat it to inlet air conditions. The preheater would use the exhaust energy for heating the ammonia vapor. This approach would use a fuel injection system for metering the hydrocarbon fuel which would be as a pilot charge during ammonia operation. This approach would be fairly straightforward and not overly costly if designed into the basic engine.

Another approach to a CI multi-fuel engine would be in having a fuel injection system that would handle either hydrocarbon or ammonia fuel. This looks like a possibility in future fuel injection concepts. This with the addition of a suitable ignition source and a variable fuel injection timing mechanism would appear to give an engine with hydrocarbon-ammonia multi-fuel capability. The preliminary data of Reference (7) would support this approach. These various approaches to multi-fuel engines are only ideas at this time and will require extensive exploratory development to prove their practicality.

CONCLUSIONS

1. In order to convert existing engines to ammonia operation only, extensive modifications are necessary for spark-ignition and compression-ignition engines. A compression-ignition engine must first be converted to a spark-ignition engine in order to operate with ammonia as an automotive fuel.
2. The conversion of the present military fleet to ammonia operation is extremely costly and impractical.
3. The increased fuel requirements for ammonia operation with current vehicles would require carrying fuel tanks which would compromise present military characteristics by increasing size and weight of vehicles with attendant reduction in vehicle performance.
4. If the requirement for ammonia operation were to be integrated into the original design of future engines and vehicles, considerable savings in weight, volume, cost and complexity could be achieved.
5. By the 1975-80 period, projected advances in technology resulting from hydrocarbon and ammonia fuel combustion research, will permit practical engines with ammonia-hydrocarbon multi-fuel capability.

GARABEDIAN and JOHNSON

REFERENCES

1. Patents of Ammonia Casale (French), 799,610 and 802,905.
2. Koch, E., "Ammonia - A Fuel for Motor Buses," Journal of the Institute of Petroleum, Vol. 31, pages 213-223, 1945.
3. "Energy Depot Concept," SAE SP-263, November 1964.
4. Starkman, E. S., Newhall, H. K., Sutton, R., Maguire, T. and Farbar, L., "Ammonia as a Spark Ignition Engine Fuel: Theory and Application," Presented at SAE Automotive Engineering Congress, Paper No. 660155, Detroit, Michigan, January 1966.
5. Gray, J. T., Dimitroff, E., Meckel, N. T. and Quillian, R. D., "Ammonia Fuel - Engine Compatibility and Combustion," Presented at SAE Automotive Engineering Congress, Paper No 660156, Detroit, Mich., January 1966.
6. Garabedian, C. G., and Johnson, J. H., "Report on the Feasibility of Using Anhydrous Ammonia as Fuel for Reciprocating Engines," Technical Report No. 9049, U. S. ATAC, Components Research and Development Laboratories, November 1965.
7. Ammonia Fuel Monthly Progress Report No. 16, Contract No. DA-04-200-AMC-791(X), 7 January 1966.
8. Wallace, W. A. and Lux, F. B., "A Variable Compression Ratio Engine Development", SAE Paper 762A, 1963.