

AD-632838



MASTER FILE
TECHNICAL
DO NOT REMOVE LIBRARY



AD

Report No. SA-TR20-9214

ROCKET FIRE CONTROL OF XM16/XM21 ARMAMENT SUBSYSTEM
FOR THE UH-1 HELICOPTER

Technical Report

Alan B. Katze, P.E.

Date 31 March 1966

DISTRIBUTION OF THIS DOCUMENT IS UNLIMITED.

SPRINGFIELD ARMORY
SPRINGFIELD, MASSACHUSETTS

MAR 31 1966
SPRINGFIELD
MASSACHUSETTS

AVAILABILITY NOTICE.

Qualified requesters may obtain copies of this report from the Defense Documentation Center, Cameron Station, Alexandria, Virginia 22314.

Other requesters may purchase copies of this report from the Clearinghouse, Department of Commerce, Springfield, Virginia 22151.

DISCLAIMERS.

The findings in this report are not to be construed as an official Department of the Army position unless so designated by other authorized documents.

The citation in this report of trade names and manufacturers does not constitute official indorsement or approval.

DISPOSITION INSTRUCTIONS.

This report is to be destroyed when it is no longer needed. It is not to be returned to the originator.

SEARCHED
SERIALIZED
INDEXED
FILED
MAY 1964
FBI - MEMPHIS

REPORT: SA-TR20-9214

DATE: 31 March 1965

AMCMS CODE: 5142.12.11204.02

ROCKET FIRE CONTROL OF XM16/XM21 ARMAMENT SUBSYSTEM

Technical Report

Alan B. Katze, P.E.

DA PROJECT TITLE: XM16 Development of Aircraft Gun Type Subsystems

DA PROJECT: 11-4-50032-(04)-M1-M6

This TECHNICAL REPORT, to the extent known, does not contain any patentable material, copyrighted and/or copyrightable material.

DISTRIBUTION OF THIS DOCUMENT IS UNLIMITED.

ABSTRACT

A rocket fire-suppression subsystem was designed and developed to arm helicopters with an increased air-to-ground defensive capability. The rocket fire control, i.e., the intervalometer, is a reliable and versatile electromechanical preset counter in which a solid-state gated relaxation-oscillator is used as a prime controller. Unique features of this subsystem are as follows: (1) All rockets are held at ground potential until ready to be fired. This completely eliminates premature and uncontrolled firing of rockets caused by electrostatic charges. (2) The firing circuit which incorporates solid-state switching is mechanically timed to prevent current flow until all switching functions are terminated. This provides a fire control with capability to perform 100,000 operating cycles with a minimum of attendant maintenance.

CONTENTS

	<u>Page</u>
Abstract	(i)
Subject	1
Objective	1
Summary of Conclusions	1
Summary of Recommendations	1
Introduction	2
Results of Activities	2
Theory of Operation	4
Theory of Operation - Intervalometer	4
Theory of Operation - Rocket Firing Circuit	6
Conclusions	7
Recommendations	7
APPENDICES	9
A - Illustrations	10
(Photographs and Schematics)	
B - Distribution	20

SUBJECT

Design and Development of a Rocket Fire-Control Subsystem

OBJECTIVE

The objective of this project was to develop a reliable intervalometer (rocket fire control) capable of firing rockets at a rate of six pairs per second for use on the XM16 or XM21 armament subsystems.

SUMMARY OF CONCLUSIONS

The design and development effort on the XM16 and/or XM21 rocket fire control has culminated in a reliable and efficient subsystem.

The reliability was established in the field by the 11th Air Assault Division (now the 1st Cavalry Division Airmobile), Fort Benning, Georgia, where eight subsystems were used on helicopters for a three-month period without reported malfunctions. This same reliability was achieved in the engineering test conducted at Aberdeen Proving Ground, Maryland.

SUMMARY OF RECOMMENDATIONS

It is probable that, with helicopters of advanced design, an increased rocket complement will be required. For this reason, the rocket fire control has been constructed to incorporate future requirements and is, therefore, recommended for use as the basic foundation for increased rocket complement systems.

1. INTRODUCTION

The rocket fire control described in this report was designed and developed specifically to meet the requirements of the XM16 and/or XM21 subsystems. The design can be expanded readily to accommodate subsystems having larger rocket complements. This fire control conforms to the following specifications:

Ripple rate.

Adjusted to six rocket pairs/second

Burst length.

One rocket pair to seven rocket pairs by increments of one pair

Operating temperature.

From -40° C. to 71° C.

Power input.

20 amperes at 28 VDC operating
.2 ampere at 28 VDC stand-by

2. RESULTS OF ACTIVITIES

a. The first intervalometer, fabricated in the Aircraft Weapon Systems Laboratory at Springfield Armory, is shown in Figures 1 and 2, Appendix A. This working model represents the culmination of design and development activities of the program to add rocket capability to helicopters equipped with the M6 armament subsystem.

b. The intervalometer was installed in a UH-1B helicopter and test-fired at Aberdeen Proving Ground, Maryland. The test was highly successful with no malfunctions occurring. At the conclusion of the test, a meeting for technical review was held at which it was decided to eliminate the "Rockets Remaining" indicator since this indicator did not directly monitor the rocket firing. Also, it was considered impractical to instrument the rocket pod for direct monitoring of rocket firing.

2. RESULTS OF ACTIVITIES - Continued

c. To effect a more reliable armament subsystem, it is necessary that the relation between weapons and rockets be such that changeability can be readily made, i.e., from guns as the primary weapon system to rockets as the primary system. This changeability was accomplished through command operation of an electrical interlock between guns and rockets.

d. The intervalometer is depicted in Figures 3, 4, and 5. This present configuration has been flight-tested (without malfunctions), and favorable reports have been received from all users. A quantity of the XM16 subsystem modification kits were produced and have been subjected to extensive evaluation by the 11th Air Assault Division (1st Cavalry Division Airmobile), Fort Benning, Georgia.

e. The development of the intervalometer resulted in a rocket fire-control subsystem which proved to be reliable during field test. The subsystem consists of two stationary, remotely controlled, 2.75 FFAR rocket pods mounted on both the left and the right sides of the helicopter and inboard of the M6 or XM134 subsystem. The rocket fire control (intervalometer) is mounted in the pedestal control console of the helicopter and is accessible to both pilot and copilot. The intervalometer is an electromechanical preset counter. When the pilot or copilot has preselected the number of rockets to be fired, the intervalometer will automatically fire that number of rockets and will reset to a start position for recurrent operation. A circuit has been incorporated into the intervalometer which provides for burst cancellation. This action is readily accomplished merely by the releasing of the trigger which immediately terminates the burst and causes the intervalometer to automatically reset.

f. The firing module (Figure 6), located in the aft fairing of the rack assembly, contains the rocket selector switch which is advanced by a signal from the intervalometer and also the solid-state switch which controls squib current. This unit, of the subsystem, is so designed that the initiation of the rocket squib is self-synchronous with the action of the rocket selector so that the contacts of the mechanical switch do not open or close while current is flowing. Thus, the power handling elements of the system operate in their maximum reliability mode. It is anticipated that these components will have a service expectancy of better than 100,000 operations. Another feature of the firing module is that it can be set to a safe position from the cockpit, thereby the pod reloading time is reduced.

2. RESULTS OF ACTIVITIES - Continued

The firing module, located in the aft fairing of the rack assembly, is an electronic switch automatically synchronized with the intervalometer and mechanically timed to allow the flow of rocket-squib current only near the limit of angular travel of a rotary stepping switch. The purpose of the mechanical timing is to prevent the flow of squib current through the switch contacts while the stepping action of the rotary solenoid is being performed. Another unique safety characteristic is the grounding of all rockets until each rocket is ready to be fired. The rocket fire-control system was designed so that it could be expanded to a larger rocket capability. This expansion is accomplished readily by the increasing of the number of positions on the firing module stepping switch and the increasing of the number of wires in the rocket cable assembly.

3. THEORY OF OPERATION

a. Theory of Operation - Intervalometer.

Two schematics of the subsystem are provided (Appendix A), one in electrical form, Figure 7, and one in logic form, Figure 8.

The intervalometer portion, Figure 7, of the rocket fire control consists of the following:

- (1) A timing module, Figure 9, is a transistorized gated relaxation oscillator with a period of not less than 167 milliseconds. The oscillator has an on-time of 30 milliseconds to 60 milliseconds and is held in its quiescent state by the grounding of the clamping diodes CR2 and CR3 through relay contacts K1-D.
- (2) A burst limiter circuit stops rocket firing when the stepping switch, SS1-A1, reaches the preselected position. This is accomplished by the completing of a ground from S2 through SS1-A1 to the clamping diodes, CR2 and CR3, located on the timing module. A burst can be terminated by the releasing of the firing switch which de-energizes relay K1 and grounds the clamping diodes CR2 and CR3 through K1-D.
- (3) A mode switch enables the pilot or copilot to select the firing of guns or rockets.

3. THEORY OF OPERATION - Continued

- (4) A momentary toggle switch, with a lift-top safety cover, provides electrical jettison capability.
- (5) Two edge-lights illuminate the control panel for night operation.

To initiate rocket firing requires that the rockets/guns switch (S1) be set to rocket position, that the rocket-pair selector-switch (S2) set to the number of rocket pairs to be fired, and that the M6 OFF-SAFE-ARM switch set to ARM position. Under these conditions, relay K3 is energized and thus prevents accidental resetting action to occur by the opening of the reset circuit through K3 relay contacts K3A and K3B.

Depressing the pilot or copilot trigger switch energizes relay K1 which arms the squib firing-circuit through relay contacts K1-A, removes supply voltage from the reset switch SS1-A front through contacts K1-B, and allows the multivibrator to oscillate by removal of the ground from the clamping diodes CR2 and CR3 through relay contacts K1-D. Relay K2, in the collector circuit of transistor Q1, will pulse and apply supply voltage to the squib selector-switches SS3 and SS4 and to the preset detector SS1. All switches will advance simultaneously one position per pulse.

The rocket burst is terminated when SS1-A1 reaches the preset position of switch S2. This is brought about by the grounding of clamping diodes CR2 and CR3 through contacts S2 and SS1-A1. Burst cancellation can be accomplished by the releasing of the trigger switch which de-energizes relay K1. This action grounds clamping diodes CR2 and CR3 through K1-D which stops the multivibrator from oscillating. Automatic resetting action occurs when relay K1 is de-energized. Voltage is then applied to SS1-A2 through K1-B, SS1-A2, interrupter contacts SS1-A-AUX, and K2-D, which automatically causes the synchronizing stepping switch SS1, to return to starting position.

Resetting of the rocket firing circuit is initiated by the placing of the M6 OFF-SAFE-ARM switch in the SAFE position. This action causes relay K3 to be de-energized. Then, by the depressing of the reset button, located on the intervalometer control panel, reset action is effected. The rocket firing circuit is described in detail in Appendix A.

3. THEORY OF OPERATION - Continued

Since it is possible for a rocket to be hit by gun fire if both are being fired simultaneously, a system interlock has been incorporated. With switch S1 in the rockets position, the guns are fired merely by the depressing of the dead-man switch and flex-sight trigger switch. However, if it is necessary to fire rockets, the pilot merely depresses the firing button and the firing of the gun is interrupted for the length of rocket firing time. This operation is accomplished in the following manner: When the pilot depresses the firing button, relay K1 will be energized; this action interrupts voltage to the M6 firing relay through relay contacts K1-C.

b. Theory of Operation - Rocket Firing Circuit.

Rocket ignition is controlled by a firing module, Figure 10, consisting of a compact, electrically operated rotary solenoid which is capable of providing sufficient mechanical power to drive a cluster of rotary wafer-switches, and a silicon-controlled rectifier (SCR) which functions as a solid-state electronic switch capable of blocking an applied voltage while in its normal state. When the appropriate voltage pulse is applied to the gate electrode, current will flow through the SCR to the load circuit. The SCR is capable of turning on in one microsecond, and turning off in fifteen microseconds.

The sequence of events which occur when the firing module is energized is as follows:

As the rotary wafer-switches are advanced to the first position, the ground is removed from Rocket 1 (Terminal A) through contacts SS3-C2. All of the other rocket positions will remain grounded. As the rotary solenoid, SS3, nears completion of the angular displacement, the mechanically synchronized interrupter-contacts, SS3-D, are opened and, momentarily, the ground is removed from the gate circuit of the SCR. This action will shift the SCR to the ON state and allow current to flow from the supply voltage through resistor R1 to contact SS3-C1 and Terminal A to the rocket squib. Resetting of the firing circuit is automatic and occurs when the rocket leaves the launcher. This allows the gate to turn OFF the SCR. Once in the OFF state, the SCR's are held in that condition by the normally closed interrupter contacts, SS3-D.

4. CONCLUSIONS

The design and development of the subject rocket fire control subsystem resulted in a lightweight single-package unit mounted in the control console of the helicopter. This subsystem was designed for a continuous long-term reliable operation. A unique characteristic of the subsystem is the mechanically timed switch which prevents the flow of rocket squib current through the switch contacts while the rotary solenoid is going through its stepping action.

5. RECOMMENDATIONS

An XM16/XM21 rocket fire control subsystem is readily adapted to the control of other rocket subsystems used in low-speed aircraft. From the point of view of economics and logistics, a basically standardized intervalometer with potential growth is advantageous. The XM16/XM21 intervalometer was designed to incorporate future requirements. Although this subsystem was designed for two 7-tube rocket launchers, one on each side of the helicopter, the intervalometer was designed to control rocket fire from any complement rocket launcher. The only modification required is the increasing of the number of positions of the rotary stepping switch (located in the firing module) and the increasing of the number of wires in the rocket cable assembly. The XM16/XM21 rocket fire control subsystem is a lightweight, low-cost, reliable system.

REPORT
SA-TR20-9214

APPENDICES

A - ILLUSTRATIONS

(Photographs and Schematics)

B - DISTRIBUTION

ILLUSTRATIONS

<u>Figure</u>	<u>Caption</u>
1	Intervalometer, XM16/XM21, Prototype, Front View
2	Intervalometer, XM16/XM21, Prototype, Top View
3	Intervalometer, XM16/XM21, Production Model
4	Intervalometer, XM16/XM21, Production Model, Top View
5	Intervalometer, XM16/XM21, Production Model, Bottom View
6	Firing Module (Photograph)
7	System Diagram (Schematic Form)
8	System Diagram (Logic Form)
9	Timing Module (Schematic Form)
10	Firing Module (Schematic Form)

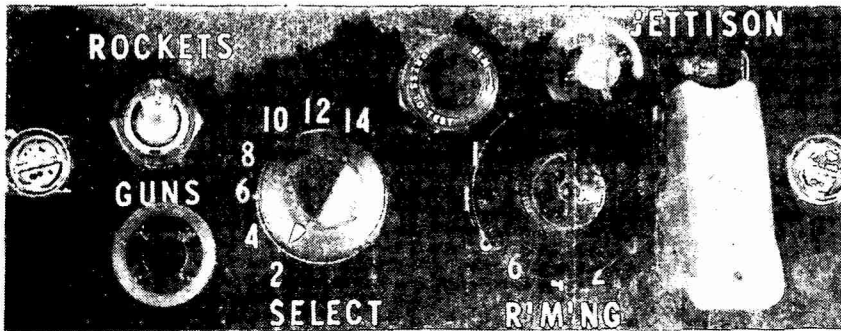

Figure 1

Intervalometer, XM16/XM21, Prototype

Front View

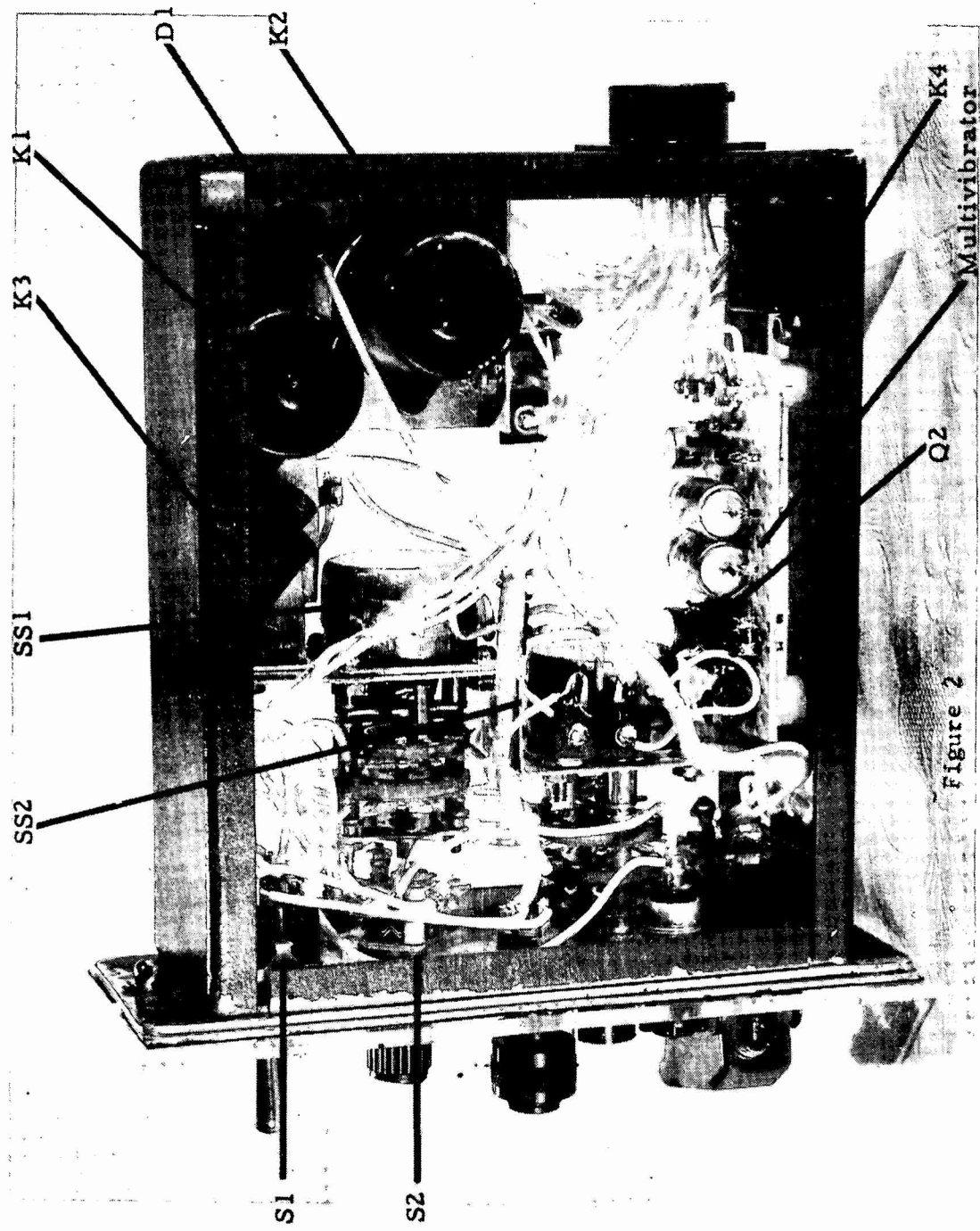

Figure 2

Intervalometer, XM16/XM21, Prototype
Top View

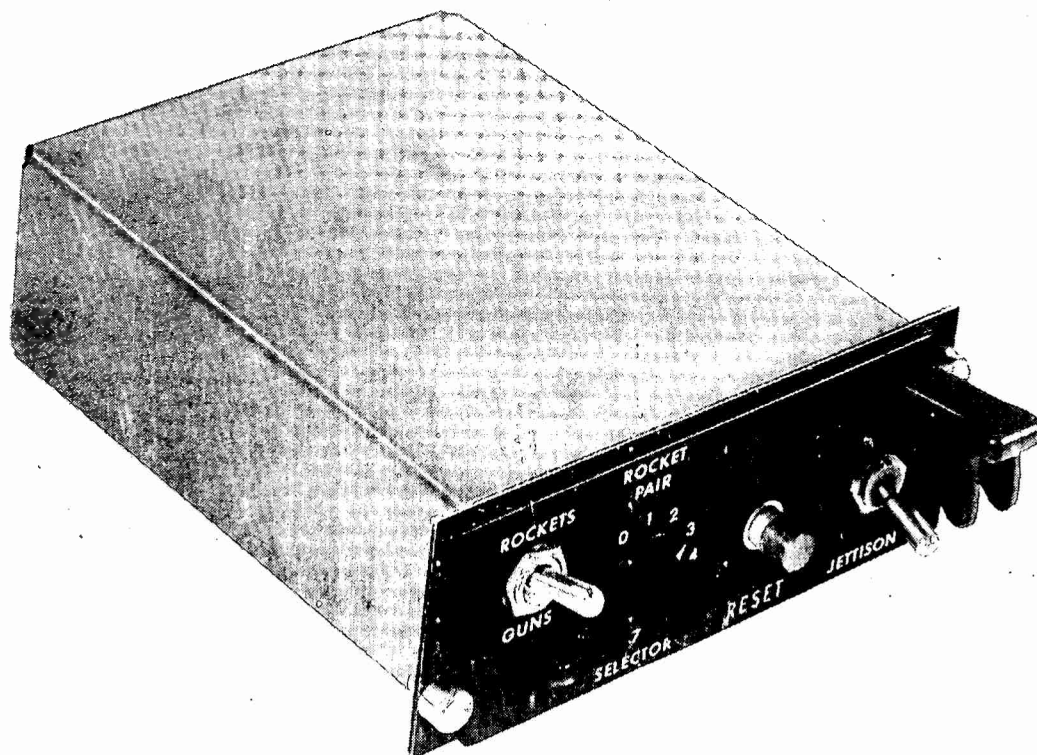

Figure 3
Intervalometer, XM16/XM21, Production Model

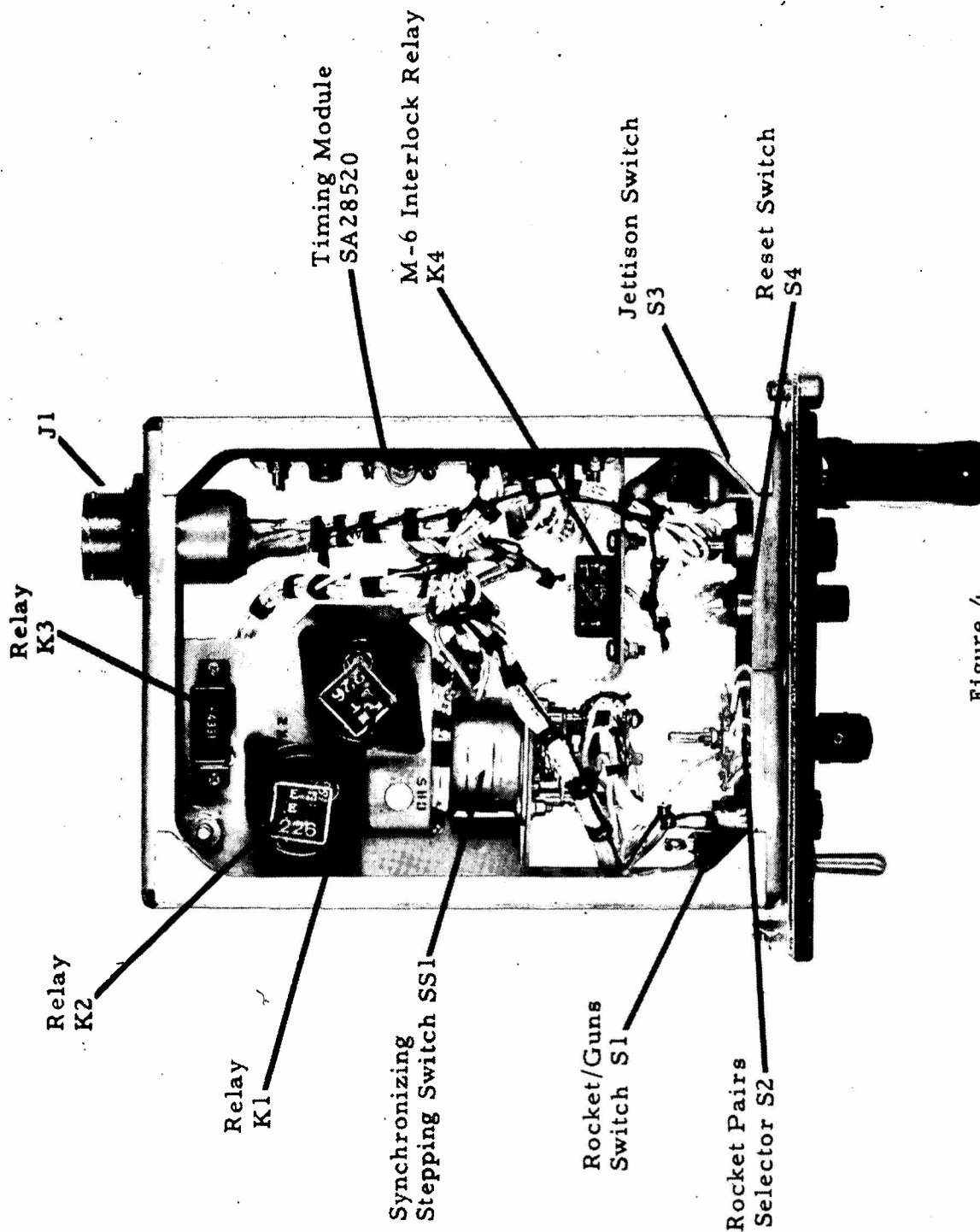

Figure 4

Intervalometer, XM16/XM21, Production Model

Top View

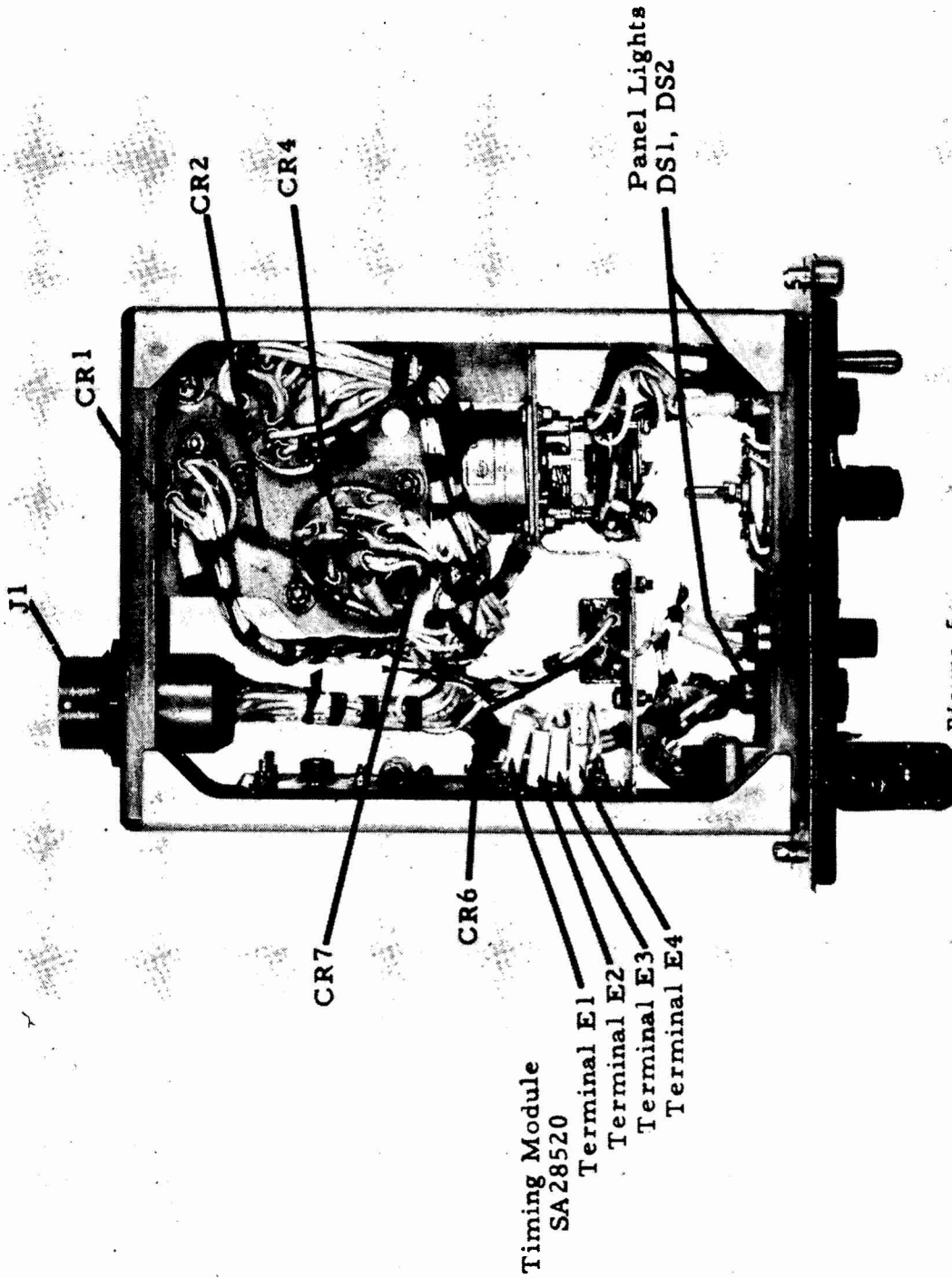

Figure 5

Intervalometer, XM16/XM21, Production Model

Bottom View

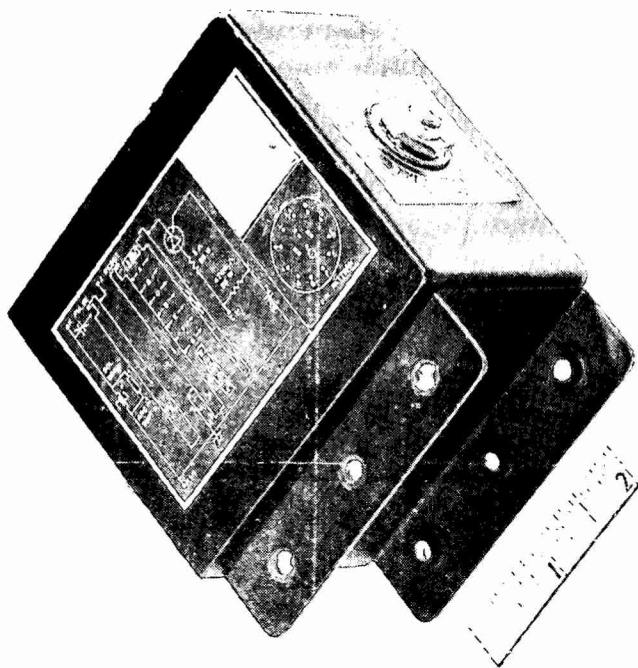
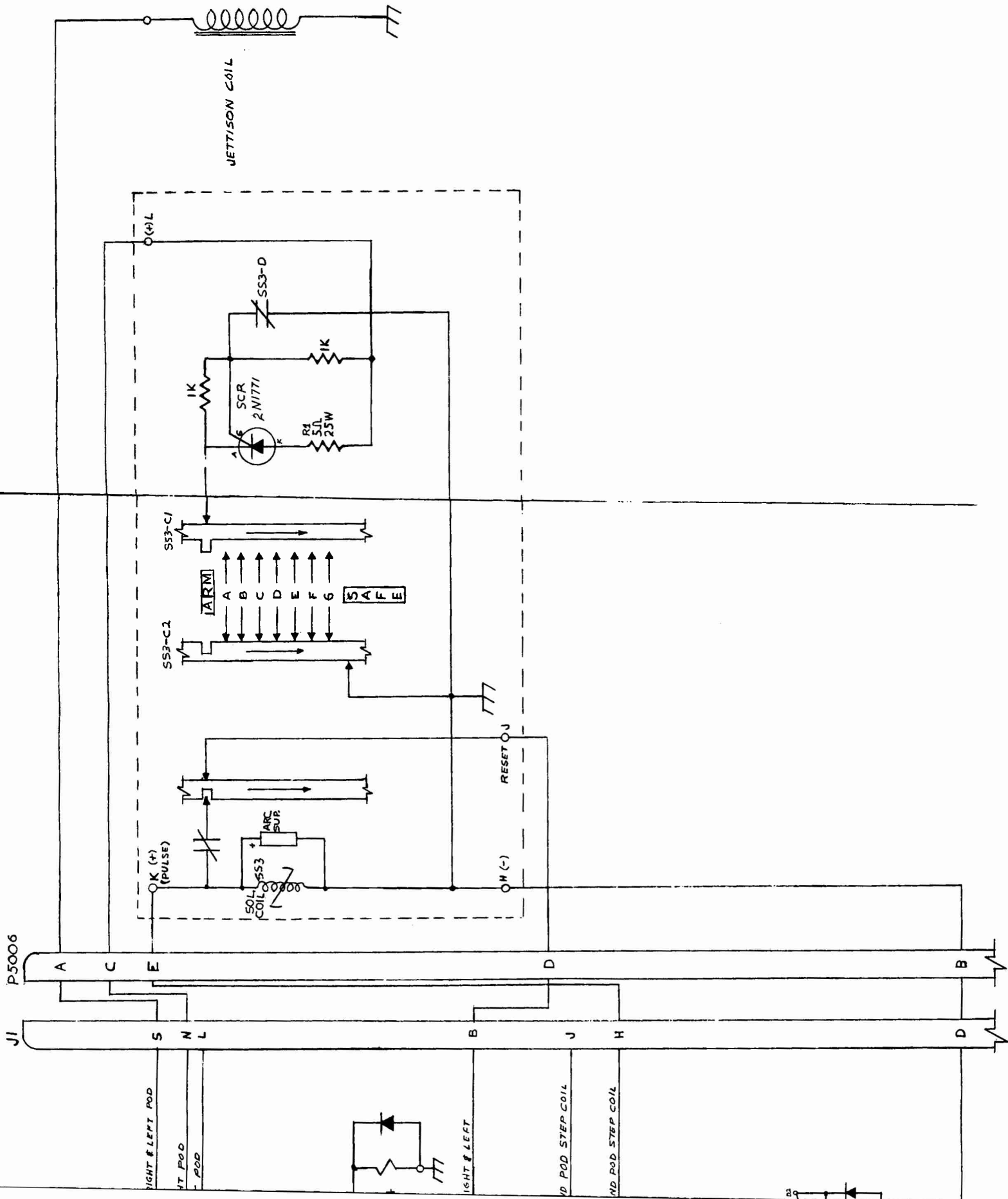

Figure 6
Firing Module

FIRING MODULE & JETTISON RELEASE SOLENOID
LOCATED IN RACK ASSEMBLIES



P5006

J1

RIGHT & LEFT POD

RT POD

LT POD

RIGHT & LEFT

RD POD STEP COIL

LD POD STEP COIL

RS

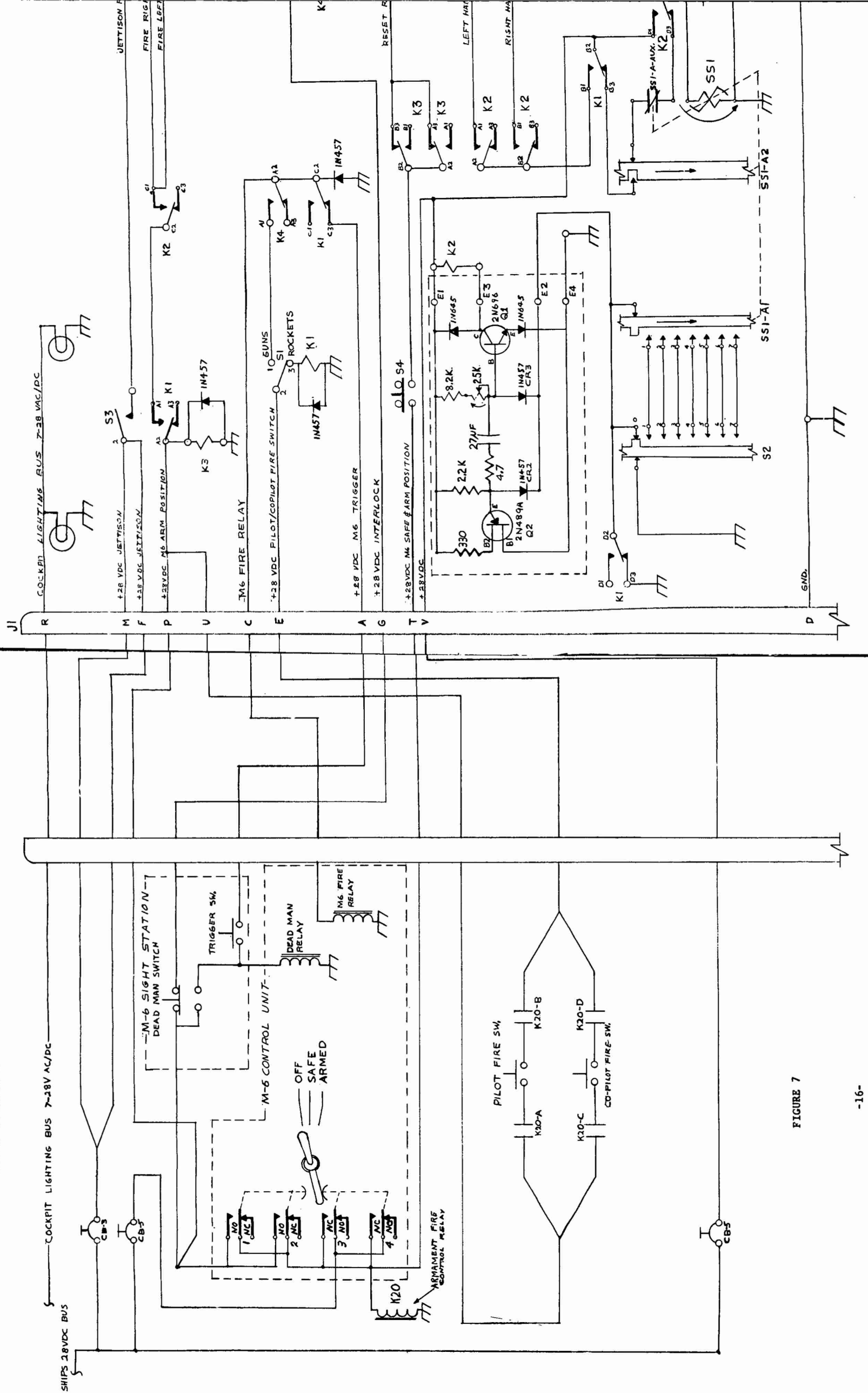
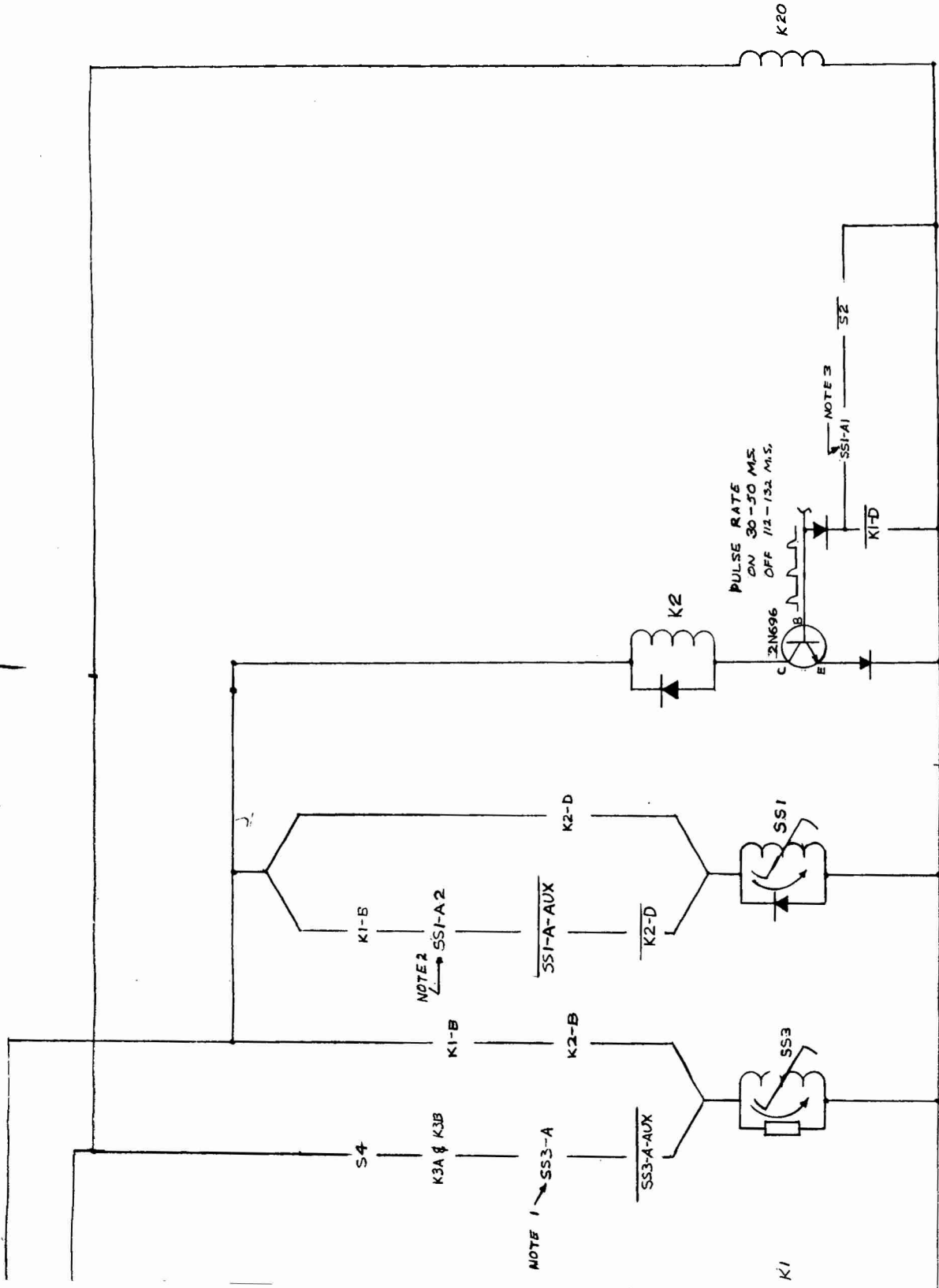

FIGURE 7

DIAGRAM



NOTES

- 1 INITIAL OR RESET POSITION IS NORMALLY OPEN. ALL OTHER POSITIONS ARE CLOSED.
- 2 HOME POSITION IS NORMALLY OPEN, ALL OTHER POSITIONS ARE CLOSED WHICH ARMS SS1 FOR AUTOMATIC RESETTING ACTION.
- 3 HOME POSITION IS NORMALLY OPEN. THE OSCILLATOR STOPS WHEN SWITCH SS1-A1 REACHES THE PRESET POSITION OF SWITCH S2.
- 4 ARMED-SAFE SWITCH SHOWN IN OFF POSITION, CONTACTS 1 & 2 ARE CLOSED IN ARM POSITION ONLY, CONTACTS 3 & 4 ARE CLOSED IN THE SAFE AND ARM POSITIONS.

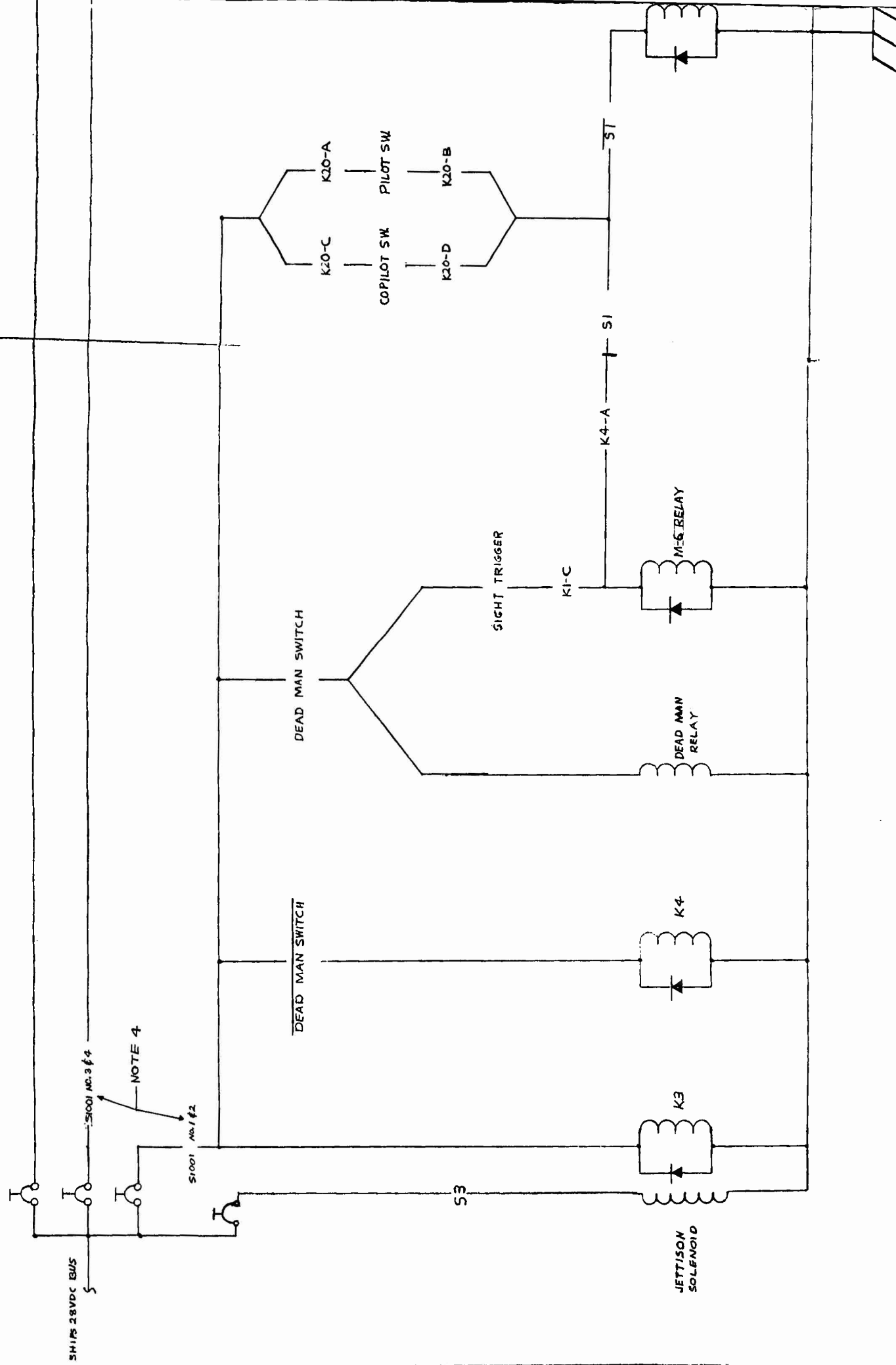

FIGURE 8

TIMING MODULE

LOCATED IN INTERVALOMETER

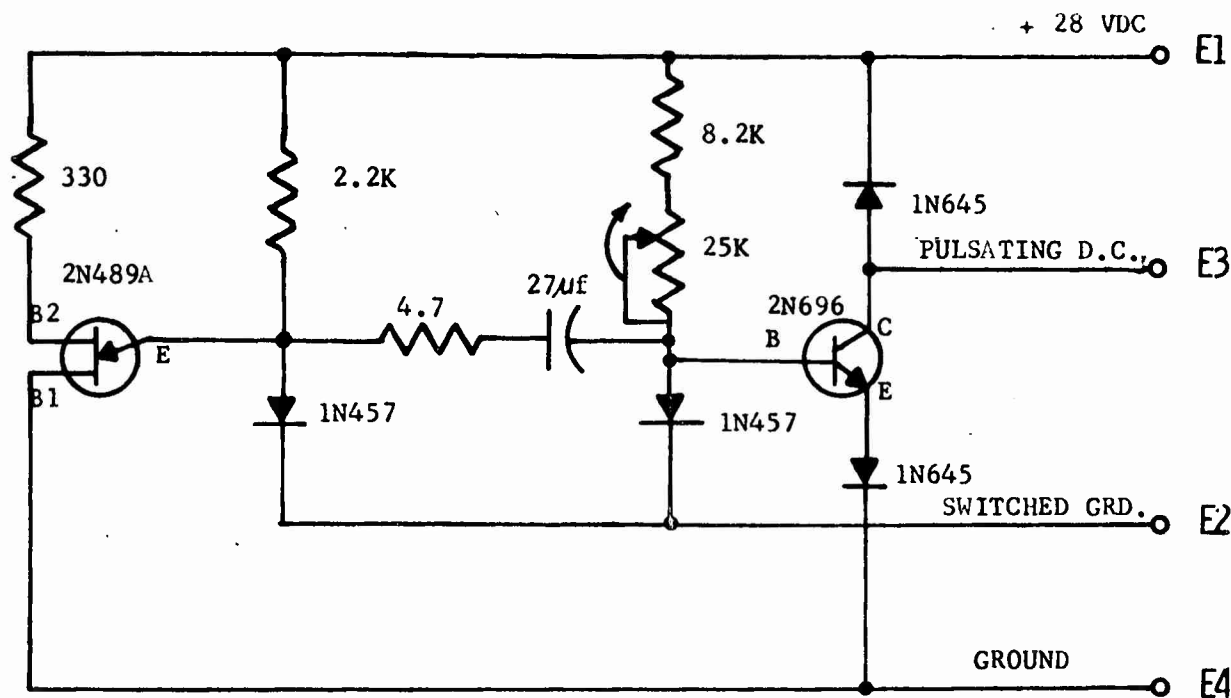

FIGURE 9

FIRING MODULE

LOCATED IN RACK FAIRING

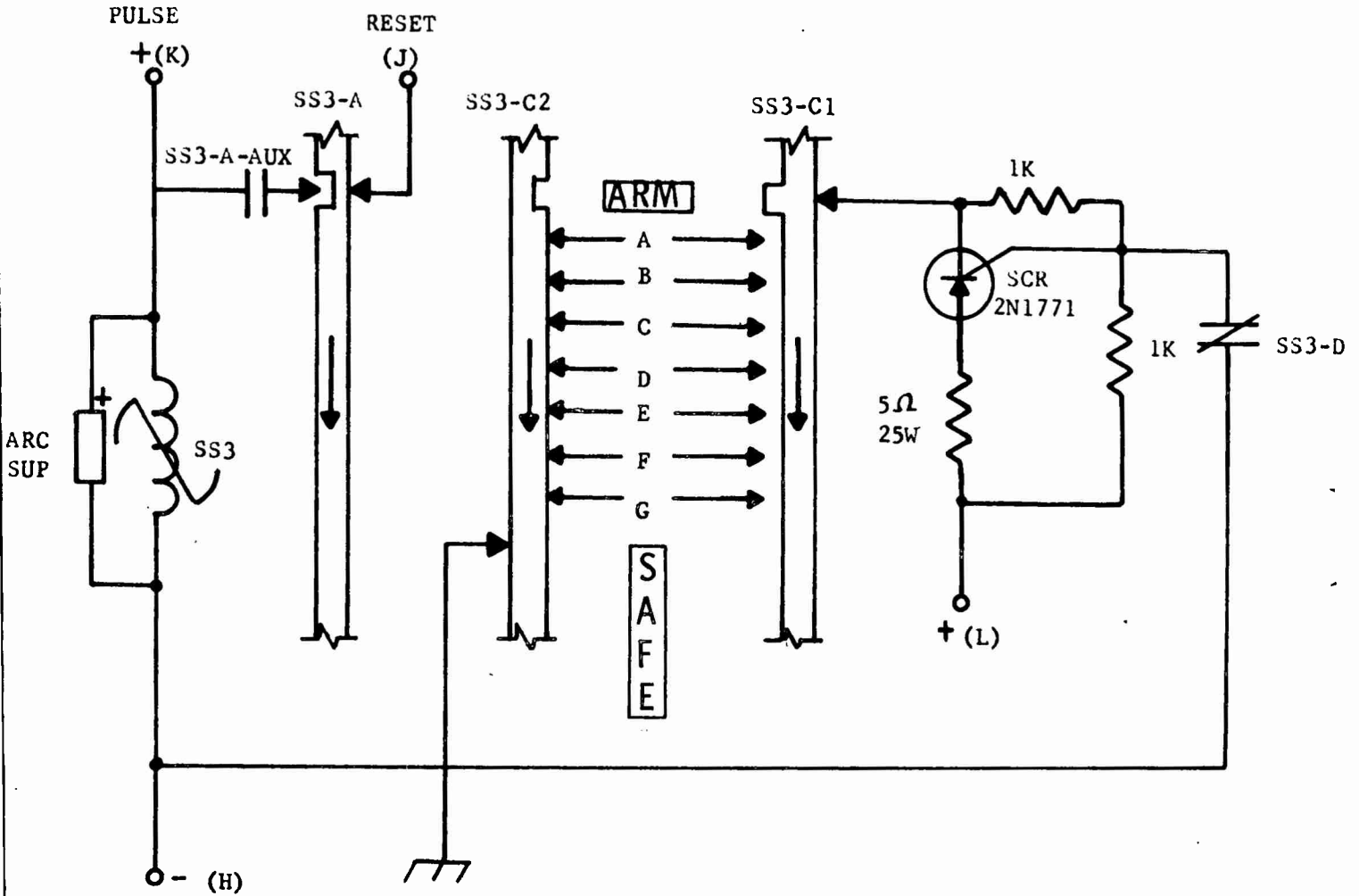

FIGURE 10

REPORT
SA-TR20-9214

APPENDIX B

DISTRIBUTION

APPENDIX B

DISTRIBUTION

REPORT
SA-TR20-9214

	<u>Copies</u>
Department of Defense Director of Defense Research and Engineering The Pentagon Washington, D. C. 20310	1
Commanding General U.S. Army Materiel Command ATTN: AMCRD (1) AMCRD-R (1) Bldg T-7, Rm 817 Washington, D. C. 20315	2
Commanding General U.S. Army Weapons Command ATTN: AMSWE-RD (2) AMSWE-PP (1) Rock Island, Illinois 61201	3
Commanding General U.S. Army Aviation Materiel Command St. Louis, Missouri 63166	1
Commanding General U.S. Army Electronics Command ATTN: AMSEL-RE Ft. Monmouth, New Jersey 07703	1
Commanding General U.S. Army Missile Command ATTN: AMSMI-RB, Redstone Scientific Information Center Redstone Arsenal, Alabama 35809	1
Commanding General U.S. Army Mobility Command ATTN: AMSMO-RDS 28251 Van Dyke Avenue Warren, Michigan 48090	1
Commanding General Edgewood Arsenal ATTN: R&D Laboratory Edgewood, Maryland 21010	1

REPORT
SA-TR20-9214

APPENDIX B

DISTRIBUTION - Continued

	<u>Copies</u>
Commanding General U.S. Army Research Office Office Chief Research and Development ATTN: Physical Sciences Division 3045 Columbia Pike Arlington, Virginia 22204	2
Commanding General U.S. Army Munitions Command ATTN: AMSMU-RE Dover, New Jersey 07801	1
Commanding General U.S. Army Natick Laboratories Kansas Street Natick, Massachusetts 01762	1
Commanding General U.S. Army Test and Evaluation Command ATTN: Technical Library, Bldg 313 (1) Director Infantry Materiel Testing (1) Aberdeen Proving Ground, Maryland 21005	2
Commanding General U.S. Army Tank-Automotive Center 28251 Van Dyke Avenue Warren, Michigan 48090	1
Commanding General White Sands Missile Range ATTN: STEWS Las Cruces, New Mexico 88002	1
Commanding Officer Detroit Arsenal Warren, Michigan 48090	1
Commanding Officer U.S. Army Materials Research Agency ATTN: TIC (1) AMXMR-ATL (1) Watertown, Massachusetts 02172	2

APPENDIX B

DISTRIBUTION - Continued

REPORT
SA-TR20-9214

	<u>Copies</u>
Commanding Officer Harry Diamond Laboratories ATTN: AMXDO-TIB Connecticut Avenue and Van Ness Street, N.W. Washington, D. C. 20438	1
Commanding Officer Defense Documentation Center Cameron Station, Bldg 5 5010 Duke Street Alexandria, Virginia 22314	20
Commanding Officer Rock Island Arsenal ATTN: SWERI-RD Rock Island, Illinois 61202	1
Commanding Officer Watervliet Arsenal ATTN: SWEVW-RD Watervliet, New York 12189	1
Commanding Officer Frankford Arsenal ATTN: SMUFA-FRA (1) Pitman-Dunn Institute for Research (1) Small Arms Division (1) Philadelphia, Pennsylvania 19137	3
Commanding Officer Picatinny Arsenal ATTN: SMUPA-V Dover, New Jersey 07801	1
Commanding Officer Army Research Office (Durham) Box CM, Duke Station Durham, North Carolina 27706	1
Commanding Officer U.S. Army Engineer Research and Development Laboratories Ft. Belvoir, Virginia 22060	1

REPORT
SA-TR20-9214

APPENDIX B

DISTRIBUTION - Continued

	<u>Copies</u>
Commanding Officer U.S. Army Electronics Research and Development Laboratories Ft. Monmouth, New Jersey 07703	1
Commanding Officer U.S. Army Ballistics Research Laboratories Aberdeen Proving Ground, Maryland 21005	1
Director U.S. Army Coating - Chemical Laboratory Aberdeen Proving Ground, Maryland 21005	1
Chief of Research and Development U.S. Army Research and Development Liaison Group APO 757 New York, N. Y. 10000	1
Chief, Office of Naval Research ATTN: Code 423 Department of the Navy Washington, D. C. 20315	1
Chief, Bureau of Naval Weapons Department of the Navy Washington, D. C. 20315	1
Director Naval Research Laboratory ATTN: Technical Information Officer Anacostia Station Washington, D. C. 20019	1
Commander U.S. Naval Ordnance Test Station ATTN: Technical Library China Lake, California 96105	1
Commanding General Wright Air Development Division ATTN: MAE (2) Wright-Patterson Air Force Base, Ohio 45433	2

APPENDIX B

DISTRIBUTION - Continued

REPORT
SA-TR20-9214

	<u>Copies</u>
U.S. Air Force Directorate, Research and Development The Pentagon, Room 4D-313 Washington, D. C. 20310	1
Clearinghouse U.S. Department of Commerce Springfield, Virginia 22151	1

UNCLASSIFIED

Security Classification

DOCUMENT CONTROL DATA - R&D

(Security classification of title, body of abstract and indexing annotation must be entered when the overall report is classified)

1. ORIGINATING ACTIVITY (Corporate author) Springfield Armory, Springfield, Massachusetts 01101		2a. REPORT SECURITY CLASSIFICATION Unclassified	
		2b. GROUP N/A	
3. REPORT TITLE ROCKET FIRE CONTROL OF XM16/XM21 ARMAMENT SUBSYSTEM FOR THE UH-1 HELICOPTER			
4. DESCRIPTIVE NOTES (Type of report and inclusive dates) Technical Report			
5. AUTHOR(S) (Last name, first name, initial) Katze, Alan B.			
6. REPORT DATE 31 March 1966		7a. TOTAL NO. OF PAGES 25	7b. NO. OF REFS None
8a. CONTRACT OR GRANT NO. N/A		9a. ORIGINATOR'S REPORT NUMBER(S) SA-TR20-9214	
b. PROJECT NO. 11-4-50032-(04)-M1-M6		9b. OTHER REPORT NO(S) (Any other numbers that may be assigned this report) N/A	
c. AMCMS CODE 5142.12.11204.02			
d.			
10. AVAILABILITY/LIMITATION NOTICES Qualified requesters may obtain copies of this report from DDC, Cameron Station, Alexandria, Virginia 22314. Others may purchase copies of this report from the Clearinghouse, Department of Commerce, Springfield, Virginia 22151			
11. SUPPLEMENTARY NOTES None		12. SPONSORING MILITARY ACTIVITY U.S. Army Materiel Command	
13. ABSTRACT <p>A rocket fire-suppression subsystem was designed and developed to arm helicopters with an increased air-to-ground defensive capability. The rocket fire control, i.e., the intervalometer, is a reliable and versatile electromechanical preset counter in which a solid-state gated relaxation-oscillator is used as a prime controller. Unique features of this subsystem are as follows: (1) All rockets are held at ground potential until ready to be fired. This completely eliminates premature and uncontrolled firing of rockets caused by electrostatic charges. (2) The firing circuit which incorporates solid-state switching is mechanically timed to prevent current flow until all switching functions are terminated. This provides a fire control with capability to perform 100,000 operating cycles with a minimum of attendant maintenance.</p>			

14. KEY WORDS	LINK A		LINK B		LINK C	
	ROLE	WT	ROLE	WT	ROLE	WT
1. Rocket fire-control subsystem						
2. Static electricity						
3. Aircraft fire-control systems						
4. Solid-state firing circuits						
5. Armament subsystem, XM16/XM21						

INSTRUCTIONS

1. **ORIGINATING ACTIVITY:** Enter the name and address of the contractor, subcontractor, grantee, Department of Defense activity or other organization (*corporate author*) issuing the report.

2a. **REPORT SECURITY CLASSIFICATION:** Enter the overall security classification of the report. Indicate whether "Restricted Data" is included. Marking is to be in accordance with appropriate security regulations.

2b. **GROUP:** Automatic downgrading is specified in DoD Directive 5200.10 and Armed Forces Industrial Manual. Enter the group number. Also, when applicable, show that optional markings have been used for Group 3 and Group 4 as authorized.

3. **REPORT TITLE:** Enter the complete report title in all capital letters. Titles in all cases should be unclassified. If a meaningful title cannot be selected without classification, show title classification in all capitals in parenthesis immediately following the title.

4. **DESCRIPTIVE NOTES:** If appropriate, enter the type of report, e.g., interim, progress, summary, annual, or final. Give the inclusive dates when a specific reporting period is covered.

5. **AUTHOR(S):** Enter the name(s) of author(s) as shown on or in the report. Enter last name, first name, middle initial. If military, show rank and branch of service. The name of the principal author is an absolute minimum requirement.

6. **REPORT DATE:** Enter the date of the report as day, month, year; or month, year. If more than one date appears on the report, use date of publication.

7a. **TOTAL NUMBER OF PAGES:** The total page count should follow normal pagination procedures, i.e., enter the number of pages containing information.

7b. **NUMBER OF REFERENCES:** Enter the total number of references cited in the report.

8a. **CONTRACT OR GRANT NUMBER:** If appropriate, enter the applicable number of the contract or grant under which the report was written.

8b, 8c, & 8d. **PROJECT NUMBER:** Enter the appropriate military department identification, such as project number, subproject number, system numbers, task number, etc.

9a. **ORIGINATOR'S REPORT NUMBER(S):** Enter the official report number by which the document will be identified and controlled by the originating activity. This number must be unique to this report.

9b. **OTHER REPORT NUMBER(S):** If the report has been assigned any other report numbers (*either by the originator or by the sponsor*), also enter this number(s).

10. **AVAILABILITY/LIMITATION NOTICES:** Enter any limitations on further dissemination of the report, other than those imposed by security classification, using standard statements such as:

- (1) "Qualified requesters may obtain copies of this report from DDC."
- (2) "Foreign announcement and dissemination of this report by DDC is not authorized."
- (3) "U. S. Government agencies may obtain copies of this report directly from DDC. Other qualified DDC users shall request through _____."
- (4) "U. S. military agencies may obtain copies of this report directly from DDC. Other qualified users shall request through _____."
- (5) "All distribution of this report is controlled. Qualified DDC users shall request through _____."

If the report has been furnished to the Office of Technical Services, Department of Commerce, for sale to the public, indicate this fact and enter the price, if known.

11. **SUPPLEMENTARY NOTES:** Use for additional explanatory notes.

12. **SPONSORING MILITARY ACTIVITY:** Enter the name of the departmental project office or laboratory sponsoring (*paying for*) the research and development. Include address.

13. **ABSTRACT:** Enter an abstract giving a brief and factual summary of the document indicative of the report, even though it may also appear elsewhere in the body of the technical report. If additional space is required, a continuation sheet shall be attached.

It is highly desirable that the abstract of classified reports be unclassified. Each paragraph of the abstract shall end with an indication of the military security classification of the information in the paragraph, represented as (TS), (S), (C), or (U).

There is no limitation on the length of the abstract. However, the suggested length is from 150 to 225 words.

14. **KEY WORDS:** Key words are technically meaningful terms or short phrases that characterize a report and may be used as index entries for cataloging the report. Key words must be selected so that no security classification is required. Identifiers, such as equipment model designation, trade name, military project code name, geographic location, may be used as key words but will be followed by an indication of technical context. The assignment of links, rules, and weights is optional.

