

AD531260



MARINE PHYSICAL LABORATORY
of the Scripps Institution of Oceanography
San Diego, California 92152

MPL PARTICIPATION IN SEALAB II

SPONSORED BY
OFFICE OF NAVAL RESEARCH
CONTRACT NONR 2216 (05)

*Reproduction in whole or in part is permitted
for any purpose of the U. S. Government*

DISTRIBUTION OF THIS DOCUMENT IS UNLIMITED

1 FEBRUARY 1966

SIO REFERENCE 66-3

CLEARINGHOUSE FOR FEDERAL SCIENTIFIC AND TECHNICAL INFORMATION		
Hardcopy	Microfilm	
\$ 2.00	\$ 0.50	45 pp 20
ARCHIVE COPY		

Code 1

UNIVERSITY OF CALIFORNIA, SAN DIEGO
MARINE PHYSICAL LABORATORY OF THE
SCRIPPS INSTITUTION OF OCEANOGRAPHY
SAN DIEGO, CALIFORNIA 92152

MPL PARTICIPATION IN SEALAB II

SPONSORED BY
OFFICE OF NAVAL RESEARCH
CONTRACT NONR 2216 (05)

SIO REFERENCE 66-3

1 FEBRUARY 1966

*Reproduction in whole or in part is permitted
for any purpose of the U. S. Government*

DISTRIBUTION OF THIS DOCUMENT IS UNLIMITED



F. N. SPIESS, DIRECTOR
MARINE PHYSICAL LABORATORY

CONTENTS

	Page
ABSTRACT.....	1
INTRODUCTION <i>Victor C. Anderson</i>	1
I-A ACOUSTIC NAVIGATION SYSTEM OFF SCRIPPS PIER <i>Michael S. Loughridge</i>	2
Introduction.....	2
System Description.....	3
Hydrophone and Cable Installation.....	4
I-B PRELIMINARY BATHYMETRY OF THE SEALAB II SITE <i>Michael S. Loughridge</i>	5
I-C BATHYMETRY OF SEALAB II AREA OF SCRIPPS CANYON <i>John D. Mudie</i>	5
Introduction.....	5
Method.....	8
Analysis.....	10
Results.....	10
II POWER AND BENTHIC INSTALLATION <i>Victor C. Anderson</i>	12
SEALAB II Installation.....	12
III THE BENTHIC LAB SYSTEM <i>Victor C. Anderson</i>	13
SEALAB-to-Shore Communications via Benthic.....	13
SEALAB Time Multiplex Data Telemetry via Benthic.....	18
Benthic-SEALAB Cables.....	21
Benthic and SEALAB Television.....	25
SEALAB Entertainment TV and Closed-Circuit TV Monitor.....	26
IV BENTHIC CONTROL COMMUNICATION <i>Victor C. Anderson</i>	26
V MANIPULATION IN THE BENTHIC LAB <i>Victor C. Anderson</i>	29
Academic.....	36
Man-months.....	38

LIST OF ILLUSTRATIONS

Figure 1 Acoustic positioning data..... 2

Figure 2 Acoustic navigation system..... 3

Figure 3 Hydrophone tripod..... 4

Figure 4 Scripps Canyon contour map..... 5

Figure 5a Bathymetric chart - western section..... 6

Figure 5b Bathymetric chart - eastern section..... 7

Figure 6a Styrofoam model of Scripps Canyon in the vicinity of *SEALAB II* site looking southeast. Numbers represent depth in feet below mean lower low water. No vertical exaggeration in model. 11

Figure 6b Styrofoam model of Scripps Canyon in vicinity of *SEALAB II* site looking from above in a southwesterly direction. Numbers represent depth in feet below mean lower low water. No vertical exaggeration in model..... 11

Figure 7 Benthic Lab..... 14

Figure 8a Ring assembly - Benthic Lab..... 15

Figure 8b Operator's console..... 16

Figure 9 Transmitter circuit - Benthic Lab..... 17

Figure 10 AMT receiver..... 18

Figure 11 Telemetry system - Benthic Lab..... 20

Figure 12 *SEALAB II* electronics rack..... 22

Figure 13 Pressure case for communications cable..... 23

Figure 14 Connector corrosion and contamination..... 24

Figure 15 Connector corrosion and contamination..... 24

Figure 16 Connector corrosion and contamination..... 24

Figure 17 Pressure-protected TV..... 27

Figure 18 Distribution of telephone calls per day by the three teams..... 29

LIST OF ILLUSTRATIONS (Continued)

Figure 19	Distribution of telephone calls per day by individual members.....	29
Figure 20	Benthic Lab configuration.....	30
Figure 21	Comparison of the resolution of the two Benthic TV cameras.....	31
Figure 22	Terminal block area.....	32
Figure 23	Plug-in monitor jack of patch panel.....	32
Figure 24	Plug-in jack #59.....	32
Figure 25a	Manipulator hand approaching monitor switch.....	33
Figure 25b	Manipulator engaged in monitor switch.....	33
Figure 26	Location of faulty card (bottom of Module 3).....	34
Figure 27	Slot from which spare diode matrix card was extracted.....	35
Figure 28	Manipulator in position to engage bottom card of Module 3.....	36
Figure 29	Manipulator in position to engage top card in Module 11.....	36

MPL PARTICIPATION IN SEALAB II

University of California, San Diego
Marine Physical Laboratory of the
Scripps Institution of Oceanography
San Diego, California 92152

ABSTRACT

This report summarizes the participation of the Marine Physical Laboratory in *SEALAB II*. It includes the results of the fine-grained, topographic survey of the site, details of and experience with the Benthic Laboratory System, and a summary of shore communication center operations during the program.

INTRODUCTION

Scripps canyon as a prospective *SEALAB II* site was the attraction which led to the participation of the Marine Physical Laboratory in the *SEALAB* project. The canyon represents one of the most intensively studied areas in submarine geology in existence, and had previously been selected as an installation site for MPL's Benthic Lab program.

The imminence of the Benthic Lab equipment led to its use in the project as a communication and data center, coupling *SEALAB* with the shore via coaxial cable. In order to satisfy *SEALAB*'s requirements, the Benthic system was adapted to the specific communication and data needs of the program, and fabrication of the equipment was greatly accelerated to meet the time schedule.

Other tasks were allotted to MPL during the project. These included a detailed site survey

in cooperation with NOTS, installation of shore power and water supply to the *SEALAB* site with the assistance of U. S. Navy Electronics Laboratory cable laying services, and furnishing miscellaneous support for the La Jolla based activity.

Responsibility for the various phases of MPL participation was diffused throughout the organization. This diffusion brought the variety of talents within MPL into play in an effective manner, accomplishing the allotted tasks with a limited manpower pool.

The format of this report reflects the variety of efforts undertaken. The contributions from the various members of the MPL staff have been collated under one cover to present a comprehensive picture of the MPL contributions to *SEALAB II*. A list of participating personnel and their area of involvement is included to indicate the level of effort expended in the project.

I-A ACOUSTIC NAVIGATION SYSTEM OFF SCRIPPS PIER

Introduction

The precise navigational requirement of the *SEALAB II* site survey led to the installation of a precision short-range navigation system off Scripps Pier. The nature of the proposed *SEALAB II* installation was such that a knowledge of the bottom topography was needed to a degree of detail far exceeding that of available charts. In order to obtain the desired survey precision the MPL deeply towed echo-sounder system was coupled with a simple acoustic beacon navigation system to provide a survey instrument of high vertical resolution and a correspondingly high level navigational accuracy.

Any of the conventional semiprecise navigational methods normally used off Scripps Pier were not considered good enough for several reasons:

- (1) The area to be surveyed was small requiring very precise fixes.
- (2) Most other systems are not 'continuous'; i.e., they are done by point-by-point measurements and could not be done rapidly enough to assist in navigating the ship through the small area to be surveyed.
- (3) Other systems would fix the position of some part of the ship—not the towed or suspended survey instrument or sampler. A towed survey vehicle may not always be directly below a fixed point on the towing ship. Such a difference in ship and survey vehicle's position may be significant in a fine-scale survey.

These objections to conventional methods led to the consideration of a properly installed acoustic 'range-range' system. Such a system offered several advantages:

- (1) The system could provide 'continuous' fixes—more often than one per second if necessary.

- (2) The navigational measurements could be referenced directly to the towed or suspended device rather than to the ship.
- (3) The acoustic positioning information could be displayed in exactly the same format as the sounding data; in fact, in practice, sounding data and positioning data were displayed on the same piece of recording paper as shown in Figure 1.

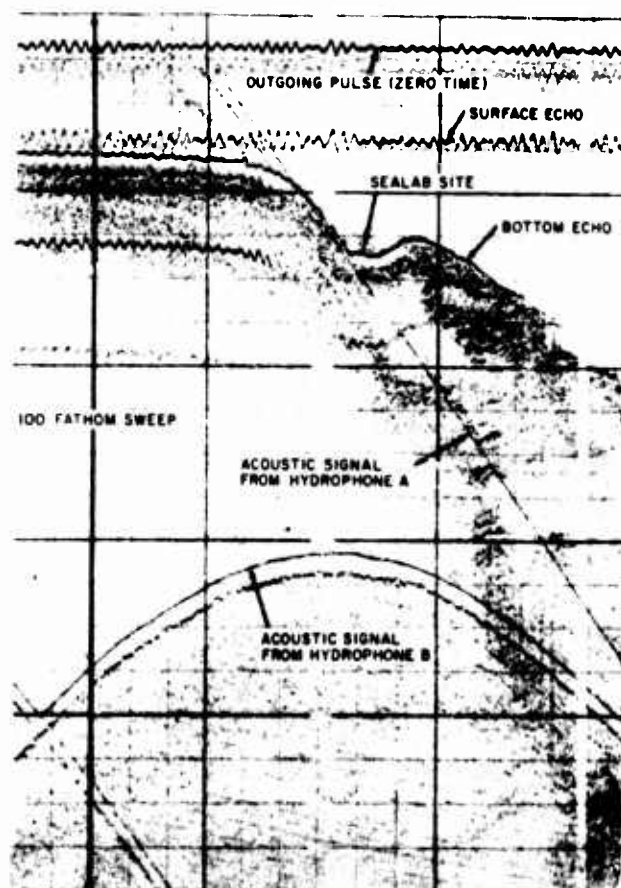

Figure 1. Acoustic positioning data

- (4) This particular system could be used in the passive as well as the active mode; for example, one could place a pinger with precision time base on the survey instrument and receive these pings at the bottom-mounted hydrophones.

(5) This system bears significant resemblance to transponder navigation systems presently under investigation by the Deep Tow group at MPL. This resemblance would allow simulation and evaluation of survey situations likely to be encountered with transponders.

System Description

The system as installed uses two or three bottom-mounted transmitting hydrophones cable-connected to shore and a listening hydrophone at the survey vehicle. Figure 2 illustrates the system configuration.

A Precision Graphic Recorder or similar device is used to key a radio transmitter at a precise repetition rate. The radio pulse as received at the pier is then used to gate an audio pulse, which is fed via cable to the bottom-mounted hydrophones. The radiated audio pulses are received at a hydrophone on the survey vehicle. The pulses received at this hydrophone are sent to the ship via cable and are amplified and displayed on the Precision Graphic Recorder.

The travel times from each transmitting hydrophone to the survey vehicle can be read directly off the PGR record. An appropriate choice of

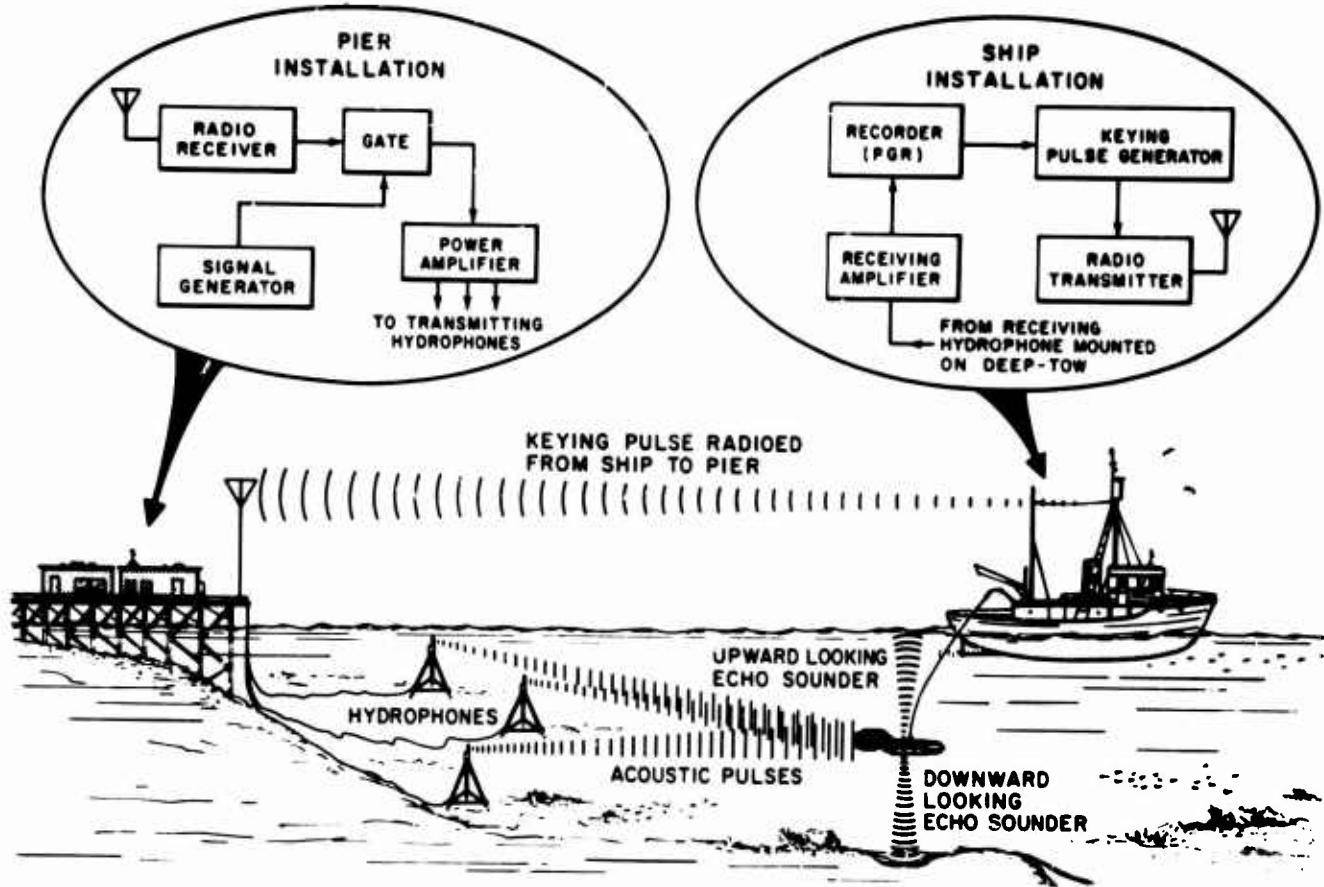

Figure 2. Acoustic navigation system

sound velocity will allow conversion of these travel times to distance and the location of the survey vehicle with respect to the bottom-mounted hydrophones can be plotted.

Hydrophone and Cable Installation

A basic installation, two bottom-mounted hydrophones, was planted off Scripps Pier on 3 February 1965. These hydrophones (Figure 3) are supported by metal tripods and connected to Scripps Pier via coaxial cable. The coaxial cable used was electrically equivalent to RG8/U but was designed with higher breaking strength and a more abrasion resistant jacket.

The two tripods and the associated cabling were installed from the *R/V OCONOSTOTA* in the following way:

- (1) The hydrophones were mated to 200-foot cables by water-tight splices. The other end of each cable was mated to a water-tight connector.
- (2) The hydrophone and cable assemblies were fastened to the tripods and lowered to the bottom on a piece of Manila line. Upon contact with the bottom, both the Manila line and the free cable end with plug were buoyed off at the surface.

At the time of hydrophone lowering, visual sights from the pier end were made on the Manila lowering line and bearings were taken at the moment of bottom contact as indicated by the slacking of the Manila line.

- (3) The two long pieces of cable were stored with water-tight plugs attached on a large-diameter reel on the stern of the *R/V OCONOSTOTA*. The free end of the outer cable was passed to the end of Scripps Pier and tied off. The *OCONOSTOTA* then slowly proceeded back to the marker buoy where the cable was passed to a skiff and the shore cable and hydrophone cable plugs were mated together.

- (4) After installation and before casting off of the buoys attached to the Manila line and plugs, an electrical check was made from shore, and divers were sent down to make sure the tripods were standing in an upright position.

This operation was repeated for the second hydrophone and cable.

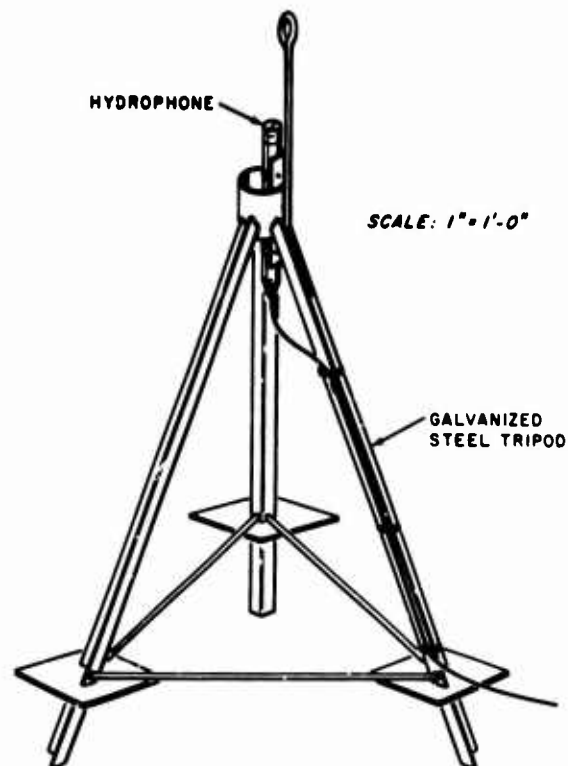

Figure 3. Hydrophone tripod

A third hydrophone was installed in a similar manner at a later date using a small barge for cable laying and hydrophone emplantment. The barge was maneuvered to a preselected position by means of optical sights from shore. At the preselected position the third tripod was lowered into place and connected to its shore cable.

The system was used effectively for the acoustic echo sounding survey where the hydrophone was 50 feet below the surface. When used with a hydrophone suspended near the bottom, terrain shadowing of the ranging signals was observed in some areas. On these occasions, the navigation was confused by multipath arrivals which did not represent a direct path range. Simplified variations in sound velocity were observed over the several months of operation of this system, and for ultimate precision corrections had to be applied. The navigational fixes obtained with the system appeared to be repeatable to within a sigma of 6 feet.

I-B PRELIMINARY BATHYMETRY OF THE SEALAB II SITE

In order to establish a basis for the selection of a site for *SEALAB II*, it was necessary to obtain additional bathymetric data in the vicinity of Scripps Canyon. The preliminary surveys utilized the MPL deeply towed echo sounder.¹ This instrument was well suited to the task because of its narrow-beam character and high resolution.

Two surveys were carried out: One on 9 February 1965 which was a general reconnaissance and another on 15 February 1965 which concentrated on a small area near the south wall of Scripps Canyon. This small area was noted on the first survey as a possible site for the *SEALAB II* program. The data from these two surveys resulted in the contour map shown in Figure 4.

Navigation for these two surveys was by means of the acoustic positioning system of section I which was installed for this purpose. The survey vehicle was tracked continuously during the surveys. Track plots were compiled in the laboratory utilizing fixes taken from the records at 20-second intervals. Depth data were plotted at the same intervals and then contoured to develop the preliminary map of Figure 4. This map

was used as the basis for selection of the initial site location. Later more detailed surveys validated this site location with only a minor shift in final position and orientation.

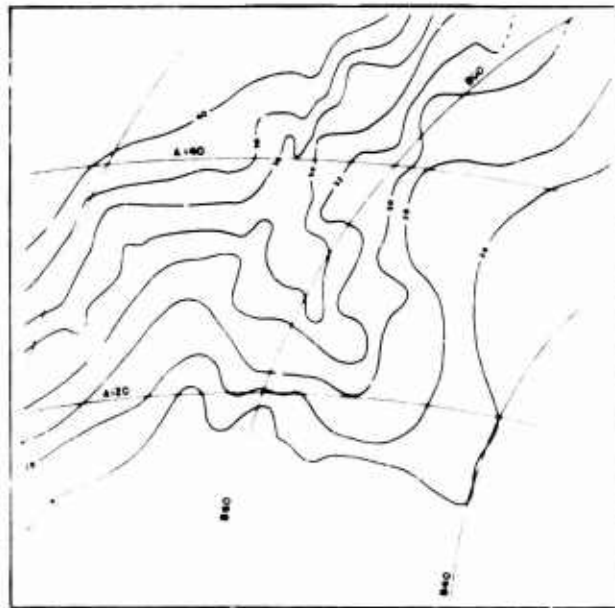

Figure 4. Scripps Canyon contour map

I-C BATHYMETRY OF SEALAB II AREA OF SCRIPPS CANYON

Introduction

Discrepancies which were observed between spot soundings and the preliminary contour chart of Figure 4 led to a decision to undertake a fine-scale survey of the *SEALAB II* area using lead line and optical survey measurements. The data of the survey consisted of approximately 500 lead-line soundings which were made in the vicinity of the south rim of the head of Scripps Canyon. A bathymetric chart of the area prepared from these data is presented together with the original data in Figures 5a and 5b. It is intended to serve:

¹ Loughbridge, M. S., *A Deeply Towed Narrow Beam Echo Sounder*. 1st USN Symposium on Military Oceanography, Vol. 1, pp 417-431 (1964) (Unclassified).

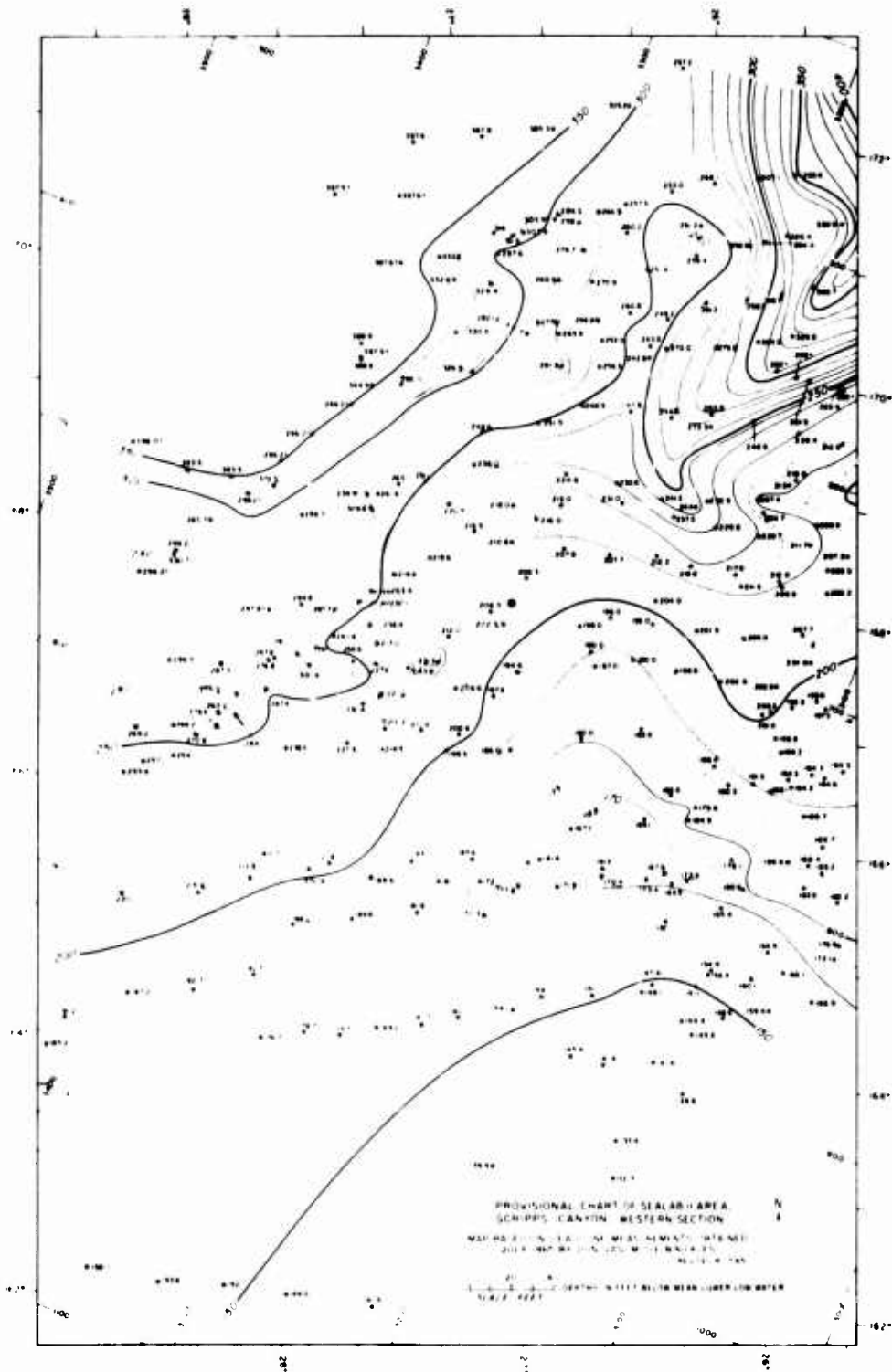

Figure 5a. Bathymetric chart - western section

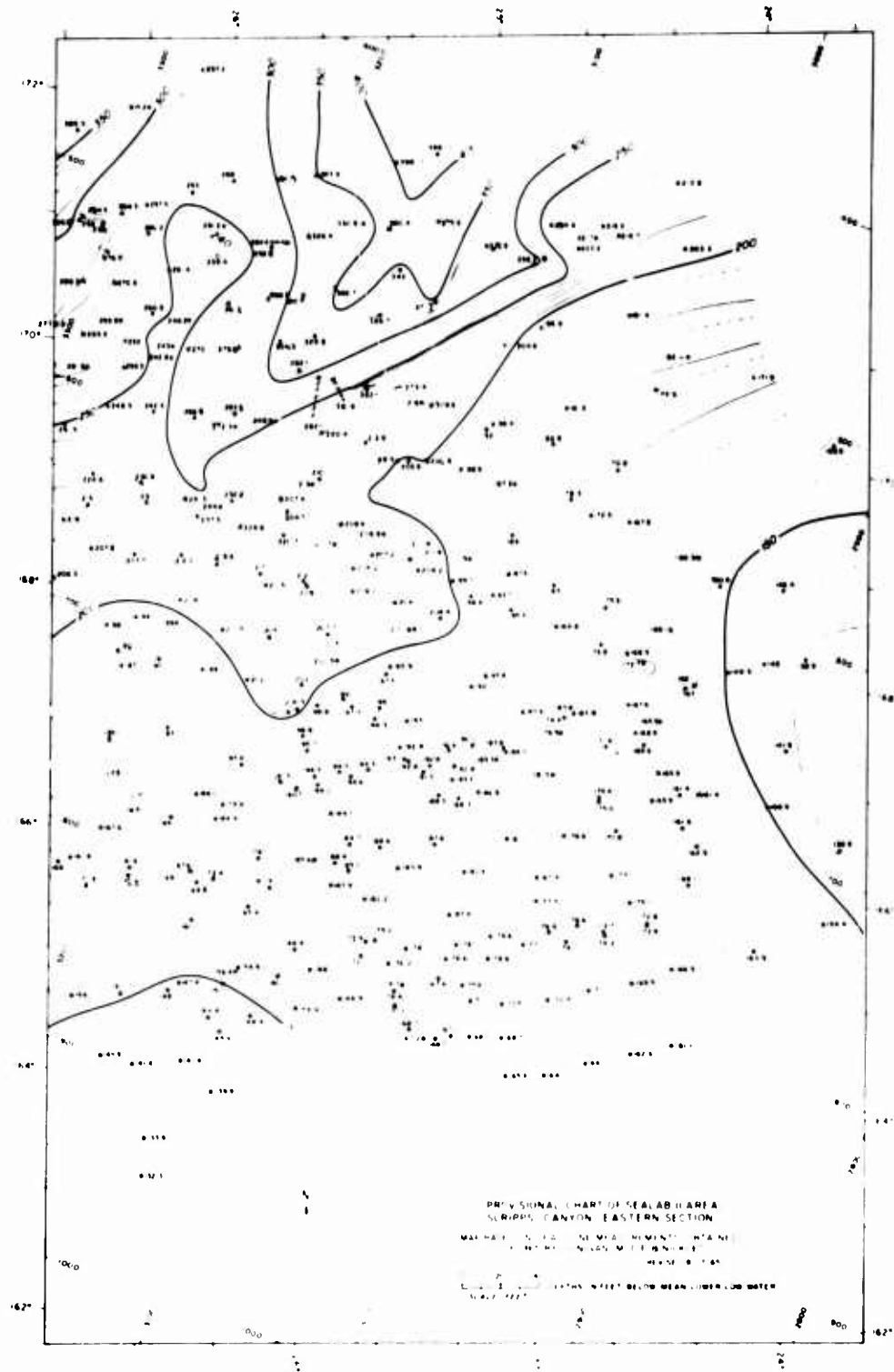

Figure 5b. Bathymetric chart - eastern section

- (1) as a description of the bottom topography for the *SEALAB II* operations;
- (2) as a finely detailed survey of part of the Scripps Canyon for use as part of an accurate chart of Scripps Canyon;
- (3) as the initial survey which, repeated in a number of years, could give quantitative information on the rates of erosion of this particular section of the canyon rim.

Method

(1) Depths

The depths were measured by bouncing a 13-lb lead weight hung from 1/8" stainless steel wire led over a measuring sheave (IBM #556000 660) loaned by E. Murray. The calibration of the sheave is described in the section 'Sheave Calibration.' The sheave meter was zeroed with the weight at the water surface before and after each set of measurements. On two out of 25 occasions the meter zero was found to be incorrect and the results preceding the meter check failure rejected up to the last meter zero check (or two successive re-confirmed soundings).

On a number of occasions, the wire used was too short to touch bottom. These points have been plotted as 'depths +' where 'depth' was the maximum length of the wire out measured with respect to mean lower low water.

At the time of writing, the depths have been converted on the basis of 3 ft 0.00 in/counter reading rather than the true 3 ft 0.11 in/counter reading. This will mean that an apparent depth of 210 ft on the chart is really at 210 ft 7.7 in. This correction will be applied to the final chart.

(2) Bounce Data

While the barge was being moved between fix points, the lead weight was 'bounced' on the bottom and the depths noted. These 'bounce' data were taken when possible and were used in the construction of the

contour lines but are not presented on the charts. The data will be made available later, together with the original data on punched cards.

(3) Navigation

The Marine Physical Laboratory barge (draft 1.5 ft, displacement 1 ton) was placed in a three-line moor over the area of interest and moved by manually hauling and slacking the mooring lines. The position of the measuring sheave was determined by visual observation through transits on shore at Scripps Pier (JDM position) and Cliff Path positions. Communication between the barge and the transit operators by means of Citizens Band transceivers enabled visual fixes to be taken within seconds of the lead weight touching the bottom.

The section 'Navigational References' contains a precise description of the location of the transits.

(4) Sheave Calibration

Apparatus:

SIO meter and sheave IBM #556000 660 connected to nominal 110-v 60-Hz supply;

Starrett steel tape, 100-ft, model HC530;

Stainless steel wire, 150 ft, 1/8-in. diameter.

Method:

The sheave was hung vertically from a hook and the wire led over it and onto the steel tape zero mark. The counter was then zeroed and, keeping at least one pound of tension on the wire passing over the sheave, the wire end was moved along the tape until a predetermined number (10, 20, 30, etc.) appeared on the counter; the position of the wire end on the steel tape was then noted. This procedure was repeated until the end of the steel tape was reached, and then the wire was pulled back in over the sheave, repeating the measurements at the predetermined counter readings.

Results:

Counter Reading	Tape Reading		Counter Reading/ Tape Reading	
	Feet	Inches	Feet	Inches
0	0	0		
20	60	1.5	3	0.07
30	90	3	3	0.10
33	99	3.5	3	0.16
30	90	3	3	0.10
20	60	2.5	3	0.12
10	30	4.2	(3	0.42)
5	15	0.5	(3	0.1)
0	0	1	()

Mean 3 ft. 0.11 in./counter reading

s.d. 0 ft. 0.04 in.

() Data omitted

(5) Navigational References

During the *SEALAB II* operations, two sets of transit stations were used. Surveyors connected with the Naval Ordnance Test Station, Pasadena, used the sites called 'Cove (*SEALAB*)' and 'View.' (Note that they called the 'Cove' site 'Dome' but in this paper the nomenclature used by NEL surveying group will be adopted to avoid confusion between the Valencia Dome and the Dome/Cove site.) The Marine Physical Laboratory used the Cliff Path station (Moran #7) and a Scripps Pier station (JDM) which differs from the Moran #4 Pier station. The MPL Pier angles were measured clockwise from the Pier Line (JDM) which differs by ~10 min from the Pier Line surveyed by NEL. The MPL Cliff angles were measured counter-clockwise from a line joining the Cliff Path and Scripps Pier (JDM) positions.

At present all the MPL navigation is given with reference to a local plane coordinate system called the SPANS coordinate system. This coordinate system had its origin at the Scripps Pier (JDM)

station, the $-x$ axis along the Pier Line (JDM) and its $+y$ axis at right angles to the x axis in a southwesterly direction.

The only reason for using this network was that the NEL survey data was not available when the SPANS coordinate system was set up and hence the convenient but very arbitrary SPANS coordinate system was used. When the NEL data was available it was immediately incorporated and measurements made to link the SPANS coordinates to the NEL coordinates. Compilation was carried out using the SPANS coordinate system and Table I shows positions in the SPANS coordinate system.

TABLE I

STATION	X ft.	Y ft.
Pier Base (JDM)	0.	0.
Cliff Path (Moran #7)	434.3	7239.2
Pier (Moran #4)	-16.9	9.9
Dike Rock (Moran #5)	-848.5	-1290.3
X (Moran Pier Survey)	6.5	2.3
Y (Moran Pier Survey)	-989.0	-0.6

Table I, showing positions of various objects on Scripps Pier acoustic navigation coordinate system.

As mentioned previously, further confirmatory soundings have yet to be made and publication of the final positions and depths will be in terms of the NEL local plane network with its origin at Dyke Rock.

The provisional charts accompanying this report have two sets of border markings. The inner set refers to the SPANS coordinate system while the outer set are sighting lines from the Cliff Path and Scripps Pier (JDM) positions.

Analysis

(1) Tide Correction

Tidal corrections have been applied to all the depths. These corrections are based on:

- i. U. S. Department of Commerce, Coast and Geodetic Survey Tide Tables for 1965 using the data on pages 71, 168 and 191 to construct a tide curve.
- ii. Observations of the Scripps Pier direct reading tide gauge, subtracting 17.0 ft from the reading to obtain the tide height.
- iii. The Scripps Pier recording tide gauge records. No significant differences between these values have been observed. Mean sea level at Scripps Pier is 2.7 ft above mean lower low water.

(2) Accuracy

The depth measurements are estimated to be accurate to within 1.5 ft and the barge sheave position to within 6 ft. Analysis of the cross-over points will be carried out later in order to give more accurate error estimates.

Results

(1) Contour Map

A contour map, Figures 5a and 5b, has been drawn to aid in the interpretation of the depth measurements. It should be used with caution and the contour map showing the actual soundings used where necessary. It should also be borne in mind that regular spacing of the contours does not indicate a smooth slope but rather a lack of data.

The western section, in particular, has a number of features depicted which are based on very few or even a complete lack of data points. The bench at 300 ft and the western bifurcate break in the canyon rim are based on very sparse data. One depth measurement has not been

reconciled with the contour lines and has a question mark adjacent to it. There is no reason to doubt the validity of this measurement and the query refers to the position of the contour lines rather than to the measurement.

(2) Topographic Model

The styrofoam model of the bottom, Figures 6a and 6b, was constructed based on the provisional contour maps. This model was constructed on a scale of 20 ft per inch in both the vertical and horizontal directions. The steep cliff faces, apparent in these photographs, accurately represent the true slopes and are not the result of vertical exaggeration.

(3) Discrepancies and Possible Errors

After the provisional charts had been drawn, Dr. D. L. Inman of Scripps Institution of Oceanography made a number of lead-line soundings in the area. In general, his measurements are in agreement with ours with the exception of our 298.2 and 310.6 measurements lying in the extreme northwest corner. His measurements (not shown on our chart) indicate a depth of 217 to 219 ft in this area. At present we suspect our measurements and thus our contour lines to be in error in this region. Further depth measurements will be made prior to final publication of the chart.

In addition, the shallow east-west gully in the southern section at 170-ft depth looks unusual and its presence will be verified later.

The suspected depth readings are underlined on the provisional charts but have been accepted as correct for contouring purposes.



Figure 6a. Styrofoam model of Scripps Canyon in the vicinity of *SEALAB II* site looking southeast. Numbers represent depth in feet below mean lower low water. No vertical exaggeration in model.



Figure 6b. Styrofoam model of Scripps Canyon in vicinity of *SEALAB II* site looking from above in a southwesterly direction. Numbers represent depth in feet below mean lower low water. No vertical exaggeration in model.

ACKNOWLEDGMENTS

The navigational data were compiled from a base survey carried out by the U. S. Navy Electronics Laboratory Field Engineering Group, Code 4253, and kindly made available by E. C. Buffington. James Moriarity, III, and Howard Shirley of Scripps Institution of Oceanography kindly carried out the contour line drawing. Margaret Robinson of Scripps supplied tide gauge data.

II POWER AND BENTHIC INSTALLATION

SEALAB II Installation

In order to satisfy the support requirements for *SEALAB II*, a high-voltage submarine power cable and two fresh water pipes were run from the end of Scripps pier to the site. Disconnect switches and overload breakers were provided at the distribution transformer pad and also at the cable termination on the end of the pier. Prior to the underwater cable installation, a length of the armored 4-conductor submarine cable was laid along the pier. The pier end of the cable was terminated in a high-voltage disconnect switch; the campus end was wired through disconnect switches to the main transformer distribution pad on the Scripps campus.

Water was supplied to the end of the pier through a 1-1/2" polyethylene pipe. At the pier end, two 3/4-hp helical rotor pumps were manifolded into the system for the purpose of boosting the pressure to a maximum of 120 psi. Each pump was capable of a 5-gallon-per-minute flow at this pressure.

The underwater submarine cable lay was terminated at a point near *SEALAB* in an underwater transformer vault. A pair of 3/4-inch, schedule 80, rigid vinyl pipes were banded to the main power cable as it was laid. The *SEALAB* end of the water lines was mechanically attached to the transformer vault and terminated in a pair of Hansen self-sealing couplers and fitted with check-valve assemblies which permitted the line to be flushed with fresh water. The shore end of the underwater cable was connected to the high-voltage disconnect switch and the shore ends of the water pipes were connected to the pump manifold.

The initial installation was made on August 20 using the original concrete hive as a housing for the transformer. The laying procedure consisted of transferring the hive, with cables and water lines attached, to the *BERKONE* by the use of the *BERKONE* crane. The power cable-water pipe bundle was then taken aboard the *BERKONE*

and stopped off with a length of nylon line. The cable layer (NEL's YFU-45) then proceeded to lay the cable in a direct line to the pier. As the cable payed out from the cable well, the water lines fed from their individual ten-foot diameter spools and were banded to the power cables just prior to passing over the forward bow sheave. The cable layer tied off to a buoy upon reaching the pier and passed the cable and water lines across to a crew on the pier end. The two water pipes were slightly short of the required length and the additional length was made up of twenty-foot lengths solvent welded with standard couplings.

While the power cable was being laid, the *BERKONE* crew attempted to place the power package on the bottom. The attempt was unsuccessful; the transformer vault was severely damaged by way of shearing off the support legs and undercarriage, and carrying away the cable gland fitting. The rigging crew and divers on board the *BERKONE* were able to salvage the concrete dome and managed to replace it on board the YFU-45 for return to the NEL waterfront area.

After laying the armored coaxial cable to shore for the future installation of the Benthic Lab, the YFU returned to the NEL pier. By virtually eliminating sleep from the personnel program, a new steel dome was fabricated over the weekend from a surplus air pressure tank previously removed from *FLIP*. On August 31 the new transformer vault was transported to the site on board the *OCONOSTOTA* where it was transferred to the *BERKONE* and a splice to the shore power cable made. After *SEALAB* was emplaced, the transformer vault was placed on the bottom by the *BERKONE* crew. The shore power and water supply were available continuously during the 45 days of *SEALAB* operation.

In the light of the experience with the concrete dome of the transformer hive, a decision was made to fabricate a new steel dome for the Benthic hive also. No existing vessel was available for this purpose and thus a 1/4-inch

steel shell was rolled and welded with a conical cover for the Benthic hive enclosure. The installation of the Benthic hive was made in the same manner as the power package. It was transported to the *BERKONE* aboard a larger ship, the *HORIZON*, transferred to the deck of the *BERKONE* and the coaxial cable splice made up. At a later time it was emplaced alongside *SEALAB* after which the aquanauts passed the flexible multiconductor cable through the cable well in *SEALAB* and made the connections into the electronics rack.

III THE BENTHIC LAB SYSTEM

The Benthic Lab, as used with *SEALAB II*, is shown in Figure 7. It is an unmanned remotely operated electronics complex housed in a kerosene-filled inverted dome or 'hive' mounted on the sea floor near the *SEALAB* habitat. This complex is connected through a single coaxial cable to the Benthic control console one mile away on shore.

In addition to control and monitor functions associated with the operation of the Benthic Lab, the electronics provides for the multiplex and de-multiplex of quite a number of television video, audio communication, and digital telemetering channels to and from *SEALAB* over the single coax to shore. The ac power required to operate the Benthic Lab is also transmitted over the same coaxial cable.

The transmission system provides for the transmission of 36 audio communication channels (AMT) with a nominal 5 kHz bandwidth, 12 channels from shore to Benthic and 24 channels from Benthic to shore. Additional provisions are made for the transmission of 5 simultaneous, 5 MHz bandwidth TV video signals from Benthic to shore. The time-multiplex telemetering system (TMT) provides 128 channels in each direction with a 60 Hz sampling rate corresponding to a 0 to 30 Hz passband on each channel.

The Benthic hive is filled with optically clear acid-washed kerosene. The interior is lighted by 16 lights which are turned on individually and in pairs via the shore-to-Benthic TMT channels. Two television cameras with remotely operated pan/tilt capability are located inside the hive and provide vision for inspection and servicing of interior electronics.

All circuits are made up on plug-in cards and are contained in 22 modular assemblies arranged in a ring around a mechanical manipulator which is operated remotely over the time-multiplex channels. The ring assembly is shown in Figure 8a. There are spare circuit cards for all critical circuits stored in the modules for easy access by the manipulator. Other features include manipulator actuated switches, both rotary and toggle, and an instrumentation patch panel where any one of over 70 voltages and waveforms may be selected for telemetering to shore for system check or trouble shooting.

A completely independent backup telemetering system providing 24 channels for critical control functions such as manipulator, lights and TV may be placed in service for trouble shooting in the event a failure should occur in the primary system.

Two hydrophones are mounted on the manipulator, one on each side. The hydrophone outputs are transmitted to shore for stereo listening in order to give the operator additional sensing of certain operating conditions which would not otherwise be available.

The operation of the Benthic Lab is carried out from the Benthic Control room located on shore. Figure 8b shows the configuration of the operator's console.

SEALAB-to-Shore Communications via Benthic

All audio communications between *SEALAB II* and shore were made via Benthic using amplitude modulated carrier transmission in the frequency band of 1 MHz to 2.2 MHz. Carrier frequencies

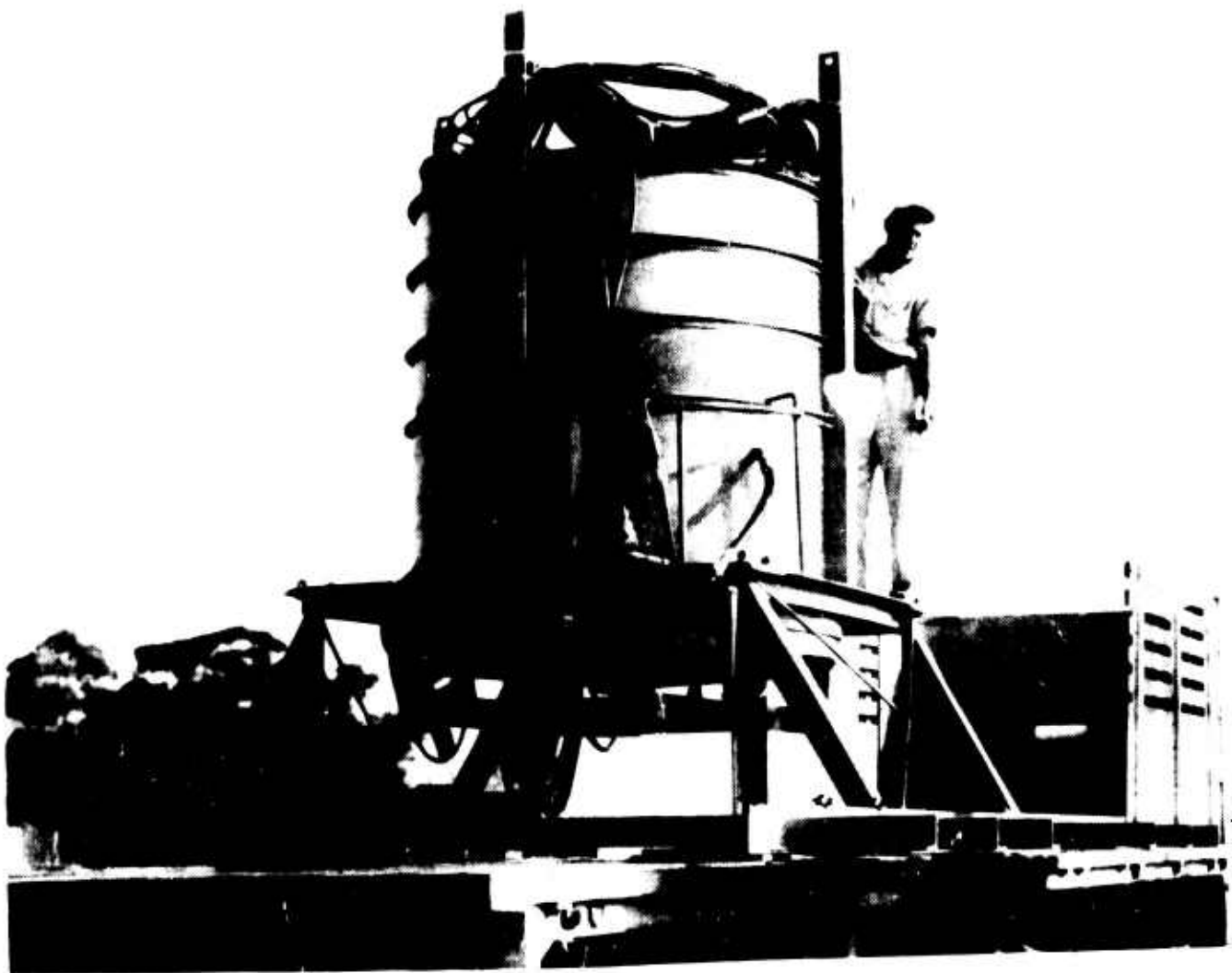

Figure 7. Benthic Lab

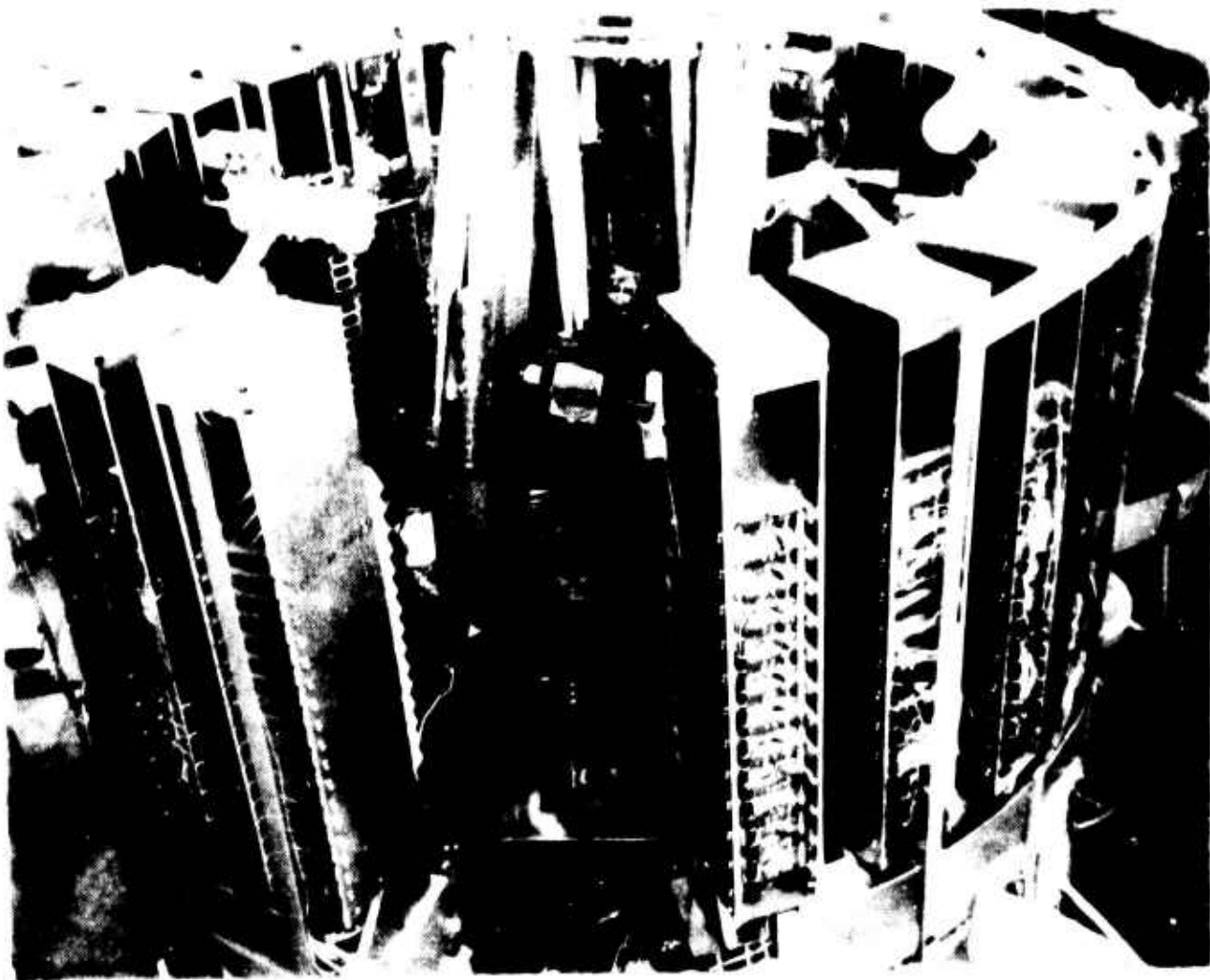

Figure 8a. Ring assembly - Benthic Lab



Figure 8b. Operator's console

were assigned with a nominal 30 kHz channel-to-channel separation and a buffer of 100 kHz between the highest frequency downgoing channel and the lowest frequency upcoming channel.

The transmitter circuit shown in Figure 9 consists of an LC oscillator, a single transistor modulator stage driven by two cascaded emitter followers and a complementary symmetry emitter follower buffering the output. The output is coupled into the transmission line through a high Q series resonant filter. Thirty-six transmitters are used, 24 in the Benthic Lab and 12 on shore in the control console.

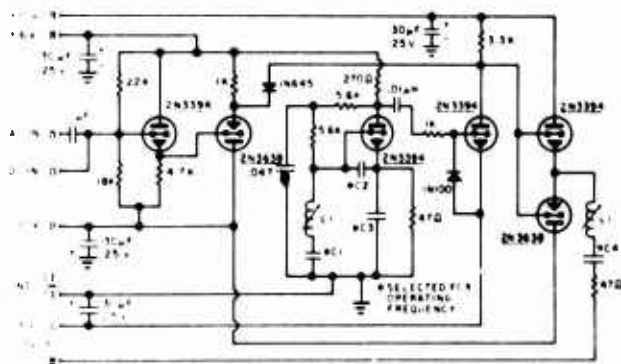

Figure 9. Transmitter circuit - Benthic Lab

The receiver circuit used is shown in Figure 10. It is a superheterodyne circuit with an RF amplifier, a series-tuned colpitts local oscillator, a separate mixer stage, two IF amplifier stages, a detector and an output buffer amplifier. Thirty-six receivers are used, 12 in the Benthic Lab and 24 on shore in the control console.

Four of the twelve downgoing AMT channels were used for television synchronization control, one was used to transmit a clock frequency for synchronization of the TMT system, six of the remaining seven channels were assigned for voice communication with *SEALAB* and the *BERKONE* and one channel was reserved as a spare.

Three channels were assigned for *SEALAB* communications with shore. One served a loud-speaker near the trunk which was a part of the primary shore communication link. Another was connected to a telephone handset near the port watch station. This circuit was used only three times in the 42 days that *SEALAB* was manned. The third receiver channel was used to drive a telephone handset near the trunk for patch into the Pacific Telephone system ashore. This circuit was used to the greatest extent.

The other three circuits were assigned for two-way communication between the *BERKONE* and shore, two for a Pacific Telephone System patch and one for routine communications to Benthic control and various offices in the *SEALAB* headquarters building. None of these circuits was ever connected or used at the Staging Vessel end, presumably because a shore telephone cable was laid furnishing adequate communications.

Terminal equipments were wired into Captain Nelson's office, the Public Information office and the psychologist's office in the headquarters building ashore for direct communication with *SEALAB* or the *BERKONE* via Benthic. These facilities were used on a very few occasions to communicate with *SEALAB*.

Of the 24 AMT channels available from Benthic to shore, six were the return channels of the two-way links assigned for *BERKONE* and *SEALAB* to shore described above. Three additional channels carried the outputs of open microphones in the galley, lab and berthing space of *SEALAB* to shore for distribution to

modules were designed to house 32 electronic switches; 16 capable of energizing 600-watt ac devices, and 16 capable of energizing 6-watt dc devices. Table II gives a breakdown of the switching functions required by the Benthic-SEALAB complex.

TABLE II

No. of Channels	Function	Actuator Type
4	Benthic Lab door	High power ac
15	Benthic Lab manipulator	High and low power ac
18	Benthic Lab TV cameras (2 ea.)	Low power ac, high power dc
18	SEALAB TV cameras (4 ea.)	Low power ac, high power dc
30	TV camera and channel selector	Low power dc
10	SIO photographic timing lights	Low power ac
8	Benthic Lab lighting	High power ac
25	Miscellaneous	

The entire TMT control system is phase-locked to a 1 MHz crystal-controlled oscillator located at Benthic Control. From this clock are generated the multiplex timing gates, and all telemetry transmission carriers. Table III lists the carrier frequency allocation and the information assigned to each.

The master oscillator frequency, carrier frequencies, and all multiplex timing gates, were obtained from standard Computer Control Company 1-MHz S-PAC equipment, in both Benthic Control and Benthic Lab. Filters, modulators, demodulators, detectors, etc., were fabricated by MPL. A block diagram of the control TMT system is shown in Figure 11.

TABLE III

Frequency	Transmitter Location	Modulator
1 MHz	Benthic Control	No modulation; transmitted via AMT channel for TMT carrier generation.
500 kHz	Benthic Lab	Benthic Lab to shore TMT signal; 500 kHz derived from 1 MHz carrier above.
250 kHz	Benthic Control	15 kHz Benthic Lab TMT clock.
167 kHz	Benthic Control	Shore to Benthic Lab TMT signal.
125 kHz	Benthic Control	60Hz data frame synchronizing signal.

Ten environmental sensors inside the SEALAB habitat and six oceanographic weather station sensors on or near the ocean floor outside produced continuous dc output voltages which were recorded or monitored within SEALAB II. These 16-sensor outputs were also sampled at intervals varying from 12 seconds to 4 minutes depending on the type of data being sampled. The data samples were coupled to the input of an A to D converter, the 12-bit binary coded output of which was transmitted to shore via the Benthic TMT system. Data sampling was programmed by a pair of electrically driven mechanical stepping switches. The commands for 'step switch advance' and 'A to D converter read' were telemetered from the digital data recording system ashore.

The digital-data recording system is primarily a recorder/recorder-programmer combination which, in detail, is a system of many functions.

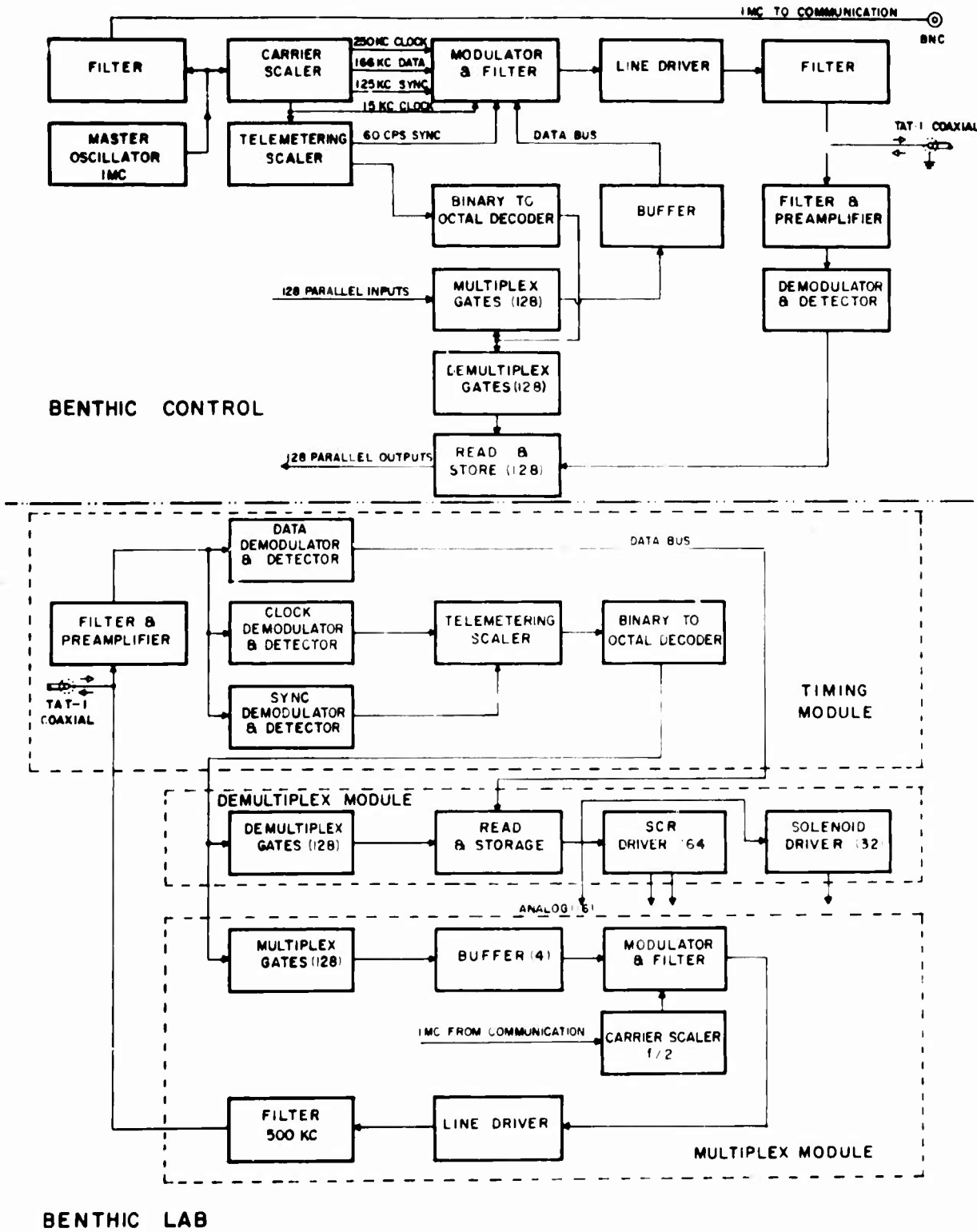

Figure 11. Telemetry system - Benthic Lab

The programmer, assembled with Computer Control Company S-PAC logic blocks plus MPL fabricated cards, provides:

- (1) The command to advance the A to D data-sampling stepping switch.
- (2) The digital recorder intercard-gap signal derived from the A to D stepping switch index.
- (3) The digital recorder step-record signal derived from 60-Hz line voltage.
- (4) The means to process the 64 data inputs (including 24 real time inputs) into a format acceptable to the digital recorder.
- (5) The timing signals for the SIO-SEALAB camera timing lights.

The recorder used is a model DSR 1430 manufactured by the Digi-Data Corp. It is a 7-track tape machine utilizing IBM-type reels and the format is compatible with IBM computers.

In addition to the 12 bits of A to D output an additional 6-bit code identifying the data being read is also telemetered ashore.

Unfortunately, the bulk of the shore-recorded data from *SEALAB II* derived from the *SEALAB* A to D system is of questionable value because conductors carrying 3 of the 18 bits were intermittent due to connector failure in the *SEALAB*-to-Benthic cables. The data transmitted raw via the AMT channels were not affected.

Other than the connector trouble and other mechanical troubles caused by repeated transport of circuit cards to and from the surface before the connector trouble was properly diagnosed, only one known failure and one possible failure occurred in the A to D programmer, A to D converter, time multiplex data transmission and recording system. The known failure was a shorted capacitor which was quickly diagnosed through a cooperative effort between *SEALAB* and Benthic Control personnel. The circuit card was sent to the surface, repaired and returned in

12 hours. The diagnosis and repair combined required an estimated 45 minutes. Transport from *SEALAB* to Benthic Control required approximately 11 hours.

The capacitor short was not attributed to pressure effects since many of the same type of capacitors have been tested to 10,000 psi without failure.

The possible failure was in a diode matrix card in the Benthic Lab which was the recipient of the major manipulation as described in Section V. As of this writing the failure has not been confirmed.

The photograph of Figure 12 shows the *SEALAB* electronics rack which houses the *SEALAB* TV control electronics at the bottom, power supplies and remote control potentiometer bank next, with the communications panels in the center, followed by the A to D converter varipak and the environmental sensor panel at the top.

Benthic-*SEALAB* Cables

Two 150-foot multiconductor cables were used to connect the Benthic Lab to *SEALAB*. Unlike the Benthic Control-Benthic Lab link, there was no multiplexing of information between these two stations; each function had an assigned wire leading to or coming from the Benthic Lab processing equipment. The Benthic Lab end of these cables was terminated at a terminal board, while the *SEALAB* was terminated with connectors. Table IV gives a general description of these two cables and their connectors.

Installation procedures called for the marriage of Benthic Lab to *SEALAB* to be made underwater. Consequently, small pressure cannisters were fabricated to seal and protect the *SEALAB* end of each cable. Each cannister was filled with alcohol to prevent sea water contamination (alcohol being a fluid compatible with the *SEALAB* atmosphere). Figure 13 shows the pressure case for the 50-conductor communications cable.

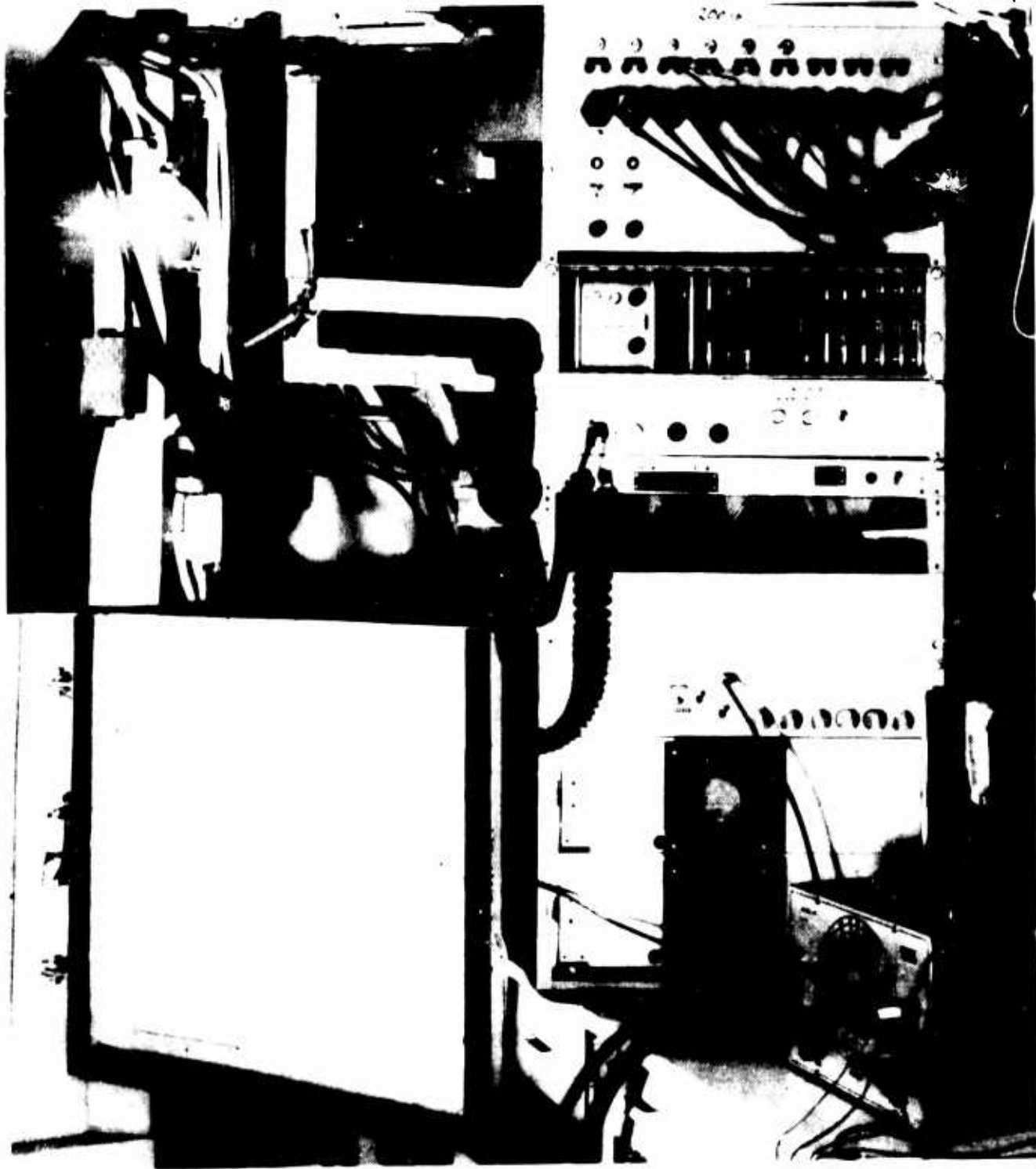

Figure 12. *SLALAB II* electronics rack

TABLE IV

Cable Type	No. of Conductors	Information Carried	Connector Types
Boston Insulated Wire TV-82	74 single-conductor plus 8 coaxial cables	A to D converter data and TV information and control	3 ea. Deutsch multi-pin 1 ea. Cannon multi-coax
Consolidated Wire No. 6025	25 twisted pairs	Communications and analog data	1 ea. Cannon multi-pin

As mentioned previously, the majority of the malfunctions associated with the *SEALAB* project were attributed to connector failure associated with these sea cables. Figures 14, 15, and 16 show various degrees of corrosion and contamination which was observed on these connectors after recovery. In most cases, specific troubles can be traced to a particular connector-pin combination where the corrosion is severe. The cause of this corrosion is unknown; however, three hypotheses are offered:

- (1) Direct contact with sea water sometime during the handling process.
- (2) Pin-to-pin arcing or electrolysis while the connectors were still in the alcohol fluid.
- (3) High ambient humidity and possible salt water splash in the environment near the *SEALAB* trunk.

In considering the above items it is interesting to note that: (1) Corrosion was also evident on the *SEALAB* rack-mounted connectors (see Figure 8b), and (2) the single connector associated with the communications cable, which is terminated only by floating transformer windings, showed no signs of deterioration.

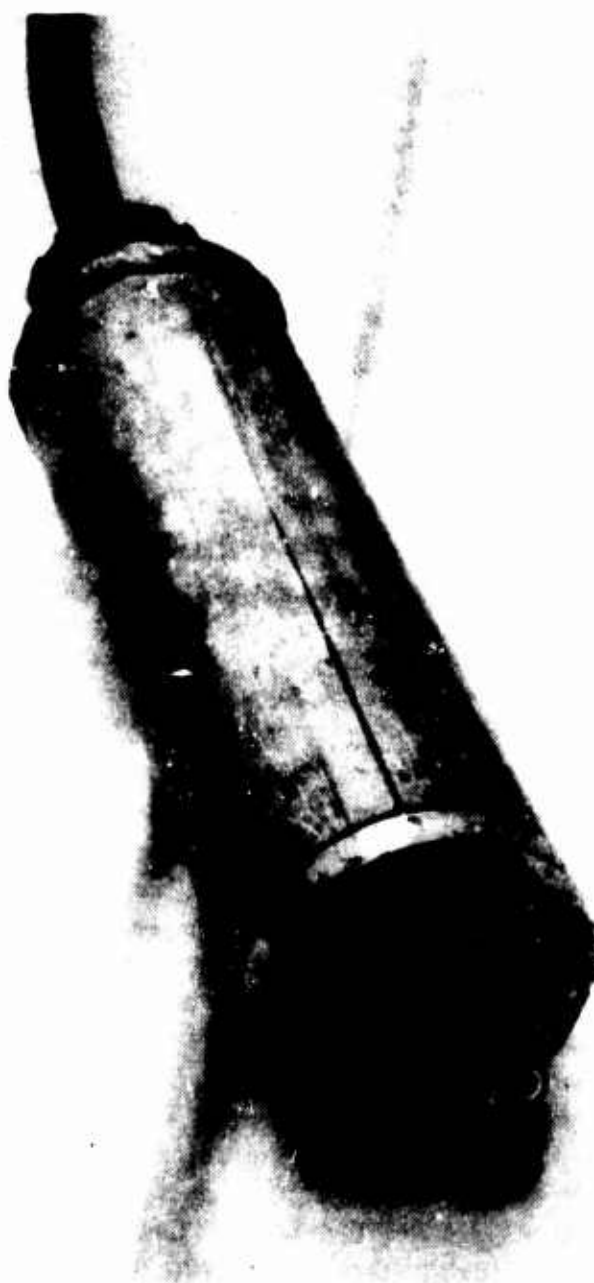

Figure 13. Pressure case for communications cable



Figure 14. Connector corrosion and contamination

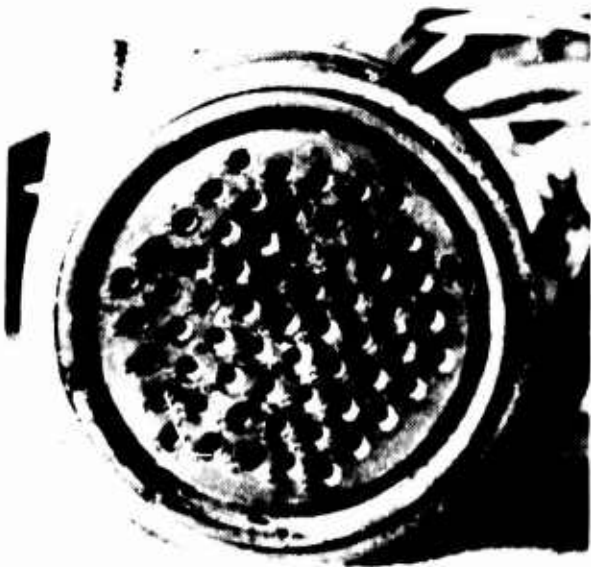

Figure 15. Connector corrosion and contamination

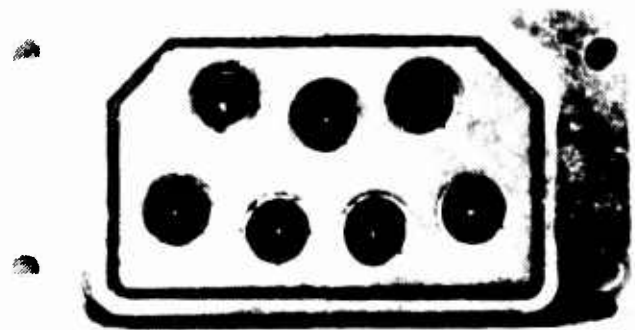

Figure 16. Connector corrosion and contamination

Benthic and SEALAB Television

The TV system for Benthic and SEALAB uses standard commercial 525 line interlace scan frequencies. Video transmission is accomplished using five amplitude modulated carriers on frequencies of 51, 60, 69, 78 and 87 MHz.

Synchronization of the two cameras in the Benthic Lab with displays in Benthic Control is by telemetered sync signals transmitted over two audio communication channels. This provides for a more reliable synchronization in low signal-to-noise ratio conditions than is obtainable with sync pulses superimposed on the video as in commercial broadcasting.

The four TV cameras provided for in SEALAB are given the capability of operating off the same telemetered sync pulses as the Benthic cameras or from an auxiliary sync generator self-contained in the SEALAB electronics rack. Due to cable connector damage suffered during the installation and Benthic-SEALAB hookup, the latter sync option was the only one usable during this period of operation.

The four cameras furnished SEALAB were duplicates of the ones designed for use in Benthic with the exception that the SEALAB cameras were not equipped with remotely operated pan/tilt mechanisms as were the two cameras used in Benthic.

Provisions were only made for remote adjustment of focus and sensitivity via Benthic telemetering from shore.

Video signals from the four SEALAB cameras were carried on separate coaxial conductors in the SEALAB-to-Benthic cabling to be placed on carriers by modulator circuits in Benthic for transmission to shore.

Three of the four video coaxial connections to Benthic, along with telemetered signals for focus and sensitivity adjustments, were lost during the initial Benthic-to-SEALAB hookup as

a result of the cable connector damage. Insufficient time was available from the tight schedule of the SEALAB crew to pinpoint the cable faults and attempt repairs.

Both cameras installed inside SEALAB functioned normally and transmitted acceptable pictures ashore via Benthic when either was connected through the one existing good video channel. Focus and sensitivity adjustments were made using a jury rig substitute in SEALAB for the lost control functions.

The two underwater cameras outside of SEALAB were never lifted out of the mud for testing, presumably because there were no additional video channels available for their use, and because the limited visibility in the surrounding water discouraged their use. One of these gave evidence of a sea ground. It was later found to have a faulty O-ring in the cable end cap.

Both inside cameras remained operable throughout the 42 days of operation but became less and less usable as a result of the many holes burned in the vidicon targets by the frequent flashing of flash bulbs by photographers in SEALAB. It is believed that the vidicons were vulnerable because of the low heat absorption characteristics of the lucite lens. A piece of heat absorbent glass was taped over the front of the lens of the one camera in use during the closing days of the operation and no additional burns appeared.

Four additional modulators were included in the TV control chassis in SEALAB for transmission of multiple video signals over a single coax in the umbilical cable to the Staging Vessel. It was reported that the signal-to-noise ratio was poor over this link. No effort was made to improve this link in view of the installation of O.E.C. cameras.

On shore at Benthic Control, TV carriers were boosted and distributed to various offices in the headquarters building and to Sumner Auditorium where they were viewed by officials of the project, the press and the public on standard commercial home entertainment-type TV receivers.

During the operation additional TV video signals from cameras supplied by Oceanographic Engineering Company were brought ashore via separate coaxial cables laid to the *BERKONE*. Additional modulators were built and put into service at Benthic Control so that these signals could also be distributed over the aforementioned network to all the monitors on shore.

SEALAB Entertainment TV and Closed-Circuit TV Monitor

In May 1965 the Marine Physical Laboratory was asked to provide *SEALAB II* with a standard broadcast entertainment TV receiver capable of safe sustained operation in the 100-psi helium atmosphere. No data were readily available on the collapse pressure of standard CRT's used in commercial TV receivers. An appeal to the local Sony and General Electric TV distributors produced two each 5-inch and 9-inch CRT's for testing. These were tubes which were electrically defective but were believed to have good envelopes. They were furnished without cost. The two 5-inch and one of the 9-inch tubes imploded within ± 5 psi of 80 psig. The other 9-inch tube imploded at less than 10 psig leading to the conclusion that it probably had a defective envelope.

The TV CRT obviously had to be protected from the *SEALAB* pressure. The first inclination was to build a pressure case around a complete TV receiver, but bringing the controls out for access posed a difficult sealing problem so a different approach was taken. A standard G.E. 9" transistorized portable receiver was procured and the CRT, horizontal-sweep circuitry and high-voltage power supply removed for installation in a pressure case. The rest of the receiver remained intact in the original cabinet with all

controls accessible. The pressure case was made of aluminum with a lucite viewing window at one end sealed with an O-ring of buna-N compound. Electrical connections were brought out through glass-to-metal seals at the other end. The completed receiver is shown in Figure 17.

Since neither the time nor the facility was available for leak testing under pressure in a helium atmosphere, a pressure gauge was installed inside the pressure case in such a way that it registered differential pressure between outside and inside. The gauge was placed for ease of viewing through the lucite window. The internal pressure increased by approximately 18 psig over the full 44-day period that *SEALAB* was down. The TV receiver worked continuously without failure. The antenna was located on the Staging Vessel *BERKONE* and coupled to the receiver through the umbilical cable.

Provisions were made to disconnect the receiver from the antenna for alternate use as a monitor for the TV cameras in *SEALAB* when required.

IV BENTHIC CONTROL COMMUNICATION

Following the installation of the Benthic Lab and its connection to *SEALAB*, a 24-hour 2-man watch was manned by Marine Physical Laboratory personnel at the Benthic Control Center in support of the *SEALAB* communications needs. During the first week of the operation one member of the 2-man team was a senior member of the technical staff. For the following weeks the watch was made up of junior members of the technical staff once standard procedures had been established and system bugs had been ironed out.

In order to assist in the planning of future communications needs for *SEALAB III* and beyond, an attempt will be made to summarize the communications traffic handled through Benthic Control in a moderate amount of detail. The basic data for this summary comes from the

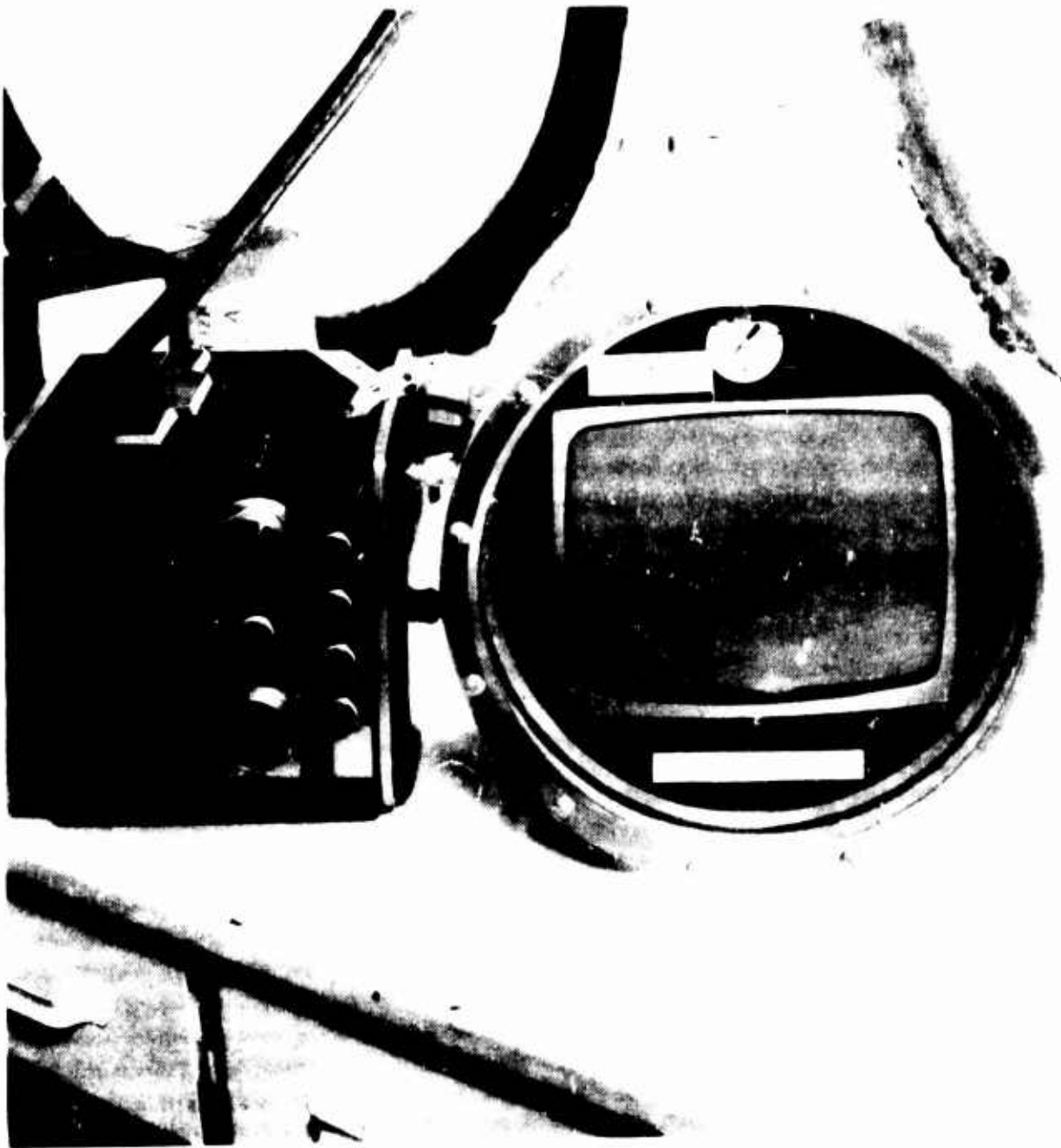

Figure 17 Pressure-protected TV

Benthic Control log and in particular from the telephone log which is a record of all *outgoing* calls originating in *SEALAB*. The breakdown of the outgoing telephone calls including both long-distance and local calls is given in Figures 18 and 19. Figure 18 shows the distribution of calls in terms of the number of calls per day in each of the three team-periods. The call rate increased from an average of 5.8 calls per day for the first team to 11.8 calls per day for the third team. This average rate of approximately one call per aquanaut per day does not report the true traffic density. Most of these calls were placed during the evening watch when reduced long-distance rates were in effect and when the aquanauts were not involved in the daily work program. The distribution of the calls in terms of the individual team members is shown in Figure 19. The distributions are essentially triangular with a nominal maximum number of calls for an individual of 35 for the second and third teams and a maximum of 12 for the first team. The rates and distributions for the second and third teams are probably more indicative of what could be expected in a future operation than those of the first team where the lack of familiarity with the system and procedures probably suppressed the use of the telephone communication link.

The over-all activity of the Benthic Control watch standers is summarized in the following list. The information was extracted from the daily log and in some cases estimated from discussions with the watch personnel. This information is also presented to attempt to outline the requirements of a communication center for future *SEALAB* programs. The activities listed cover a 40-day period.

Telephone calls from <i>SEALAB</i>	355
Estimated telephone calls to <i>SEALAB</i>	420
Estimated telephone calls to University extensions	180
1) Calls from Benthic to <i>SEALAB II</i> for various equipment checks	37

2) Calls from Benthic Control to <i>SEALAB</i> for equipment repairs	20
3) Calls from <i>SEALAB II</i> to Benthic Control for equipment check and repair information	11
4) Visit to Benthic Control for conversations with <i>SEALAB II</i> personnel	21
5) Requests to Benthic Control personnel for additional work needed to be done by Benthic Control personnel	75
6) Visits by authorized personnel to Benthic Control to show <i>SEALAB II</i> operation to visitors	25
7) Set up interviews with <i>SEALAB II</i> personnel	10
8) Transfer of equipment to and from <i>SEALAB II</i> via staging vessel	19
9) Relay messages to and from <i>SEALAB II</i>	13
10) Patch special phone connections	10
11) Record audio conversations with <i>SEALAB II</i>	3
12) Assist in video recordings of <i>SEALAB II</i>	4
13) Communication, Benthic Control to <i>BERKONE</i>	16
14) Communication, Benthic Control to <i>SEALAB</i> Headquarters via intercom (estimated)	350
15) Psychologists visits to Benthic Control to verify communications with <i>SEALAB II</i>	12
16) Visits to Benthic Control to discuss equipment changes and malfunctions with Benthic personnel	11
17) Miscellaneous—take pictures, distribute information, locate personnel, answer questions, etc. (estimated)	200

These activities do not cover the assistance which was given to the *SEALAB* project in small-boat operations and radio relay service during the period of installation prior to the operation of the Benthic Laboratory. The small boat services were sufficiently intensive to virtually demolish a new 14-foot Boston Whaler in repeated landings at the dock and the *BERKONE*. The

radio traffic was very heavy prior to the installation of the Pacific Telephone lines to the *BERKONE*.

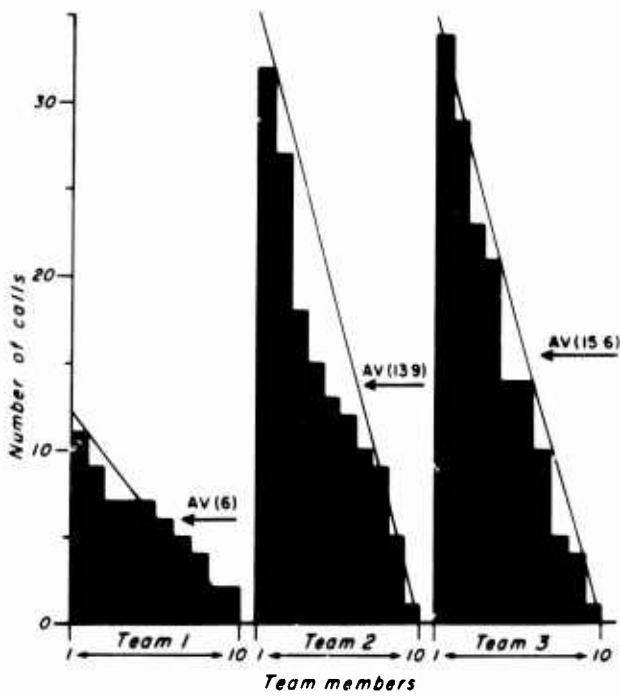

Figure 18. Distribution of telephone calls per day by the three teams

V MANIPULATION IN THE BENTHIC LAB

The initial attempt at manipulation within the Benthic hive was carried out on September 1, the day after the emplantment of the Benthic Lab. The attempt was made using Benthic TV camera number 2, located between modules 22 and 23, near the TV modulator cards in module 21 (Figure 20). This particular TV camera appeared to be faulty, and the picture definition was very poor, indicating either an oil leakage into the optics or a faulty electromagnetic focus circuit.

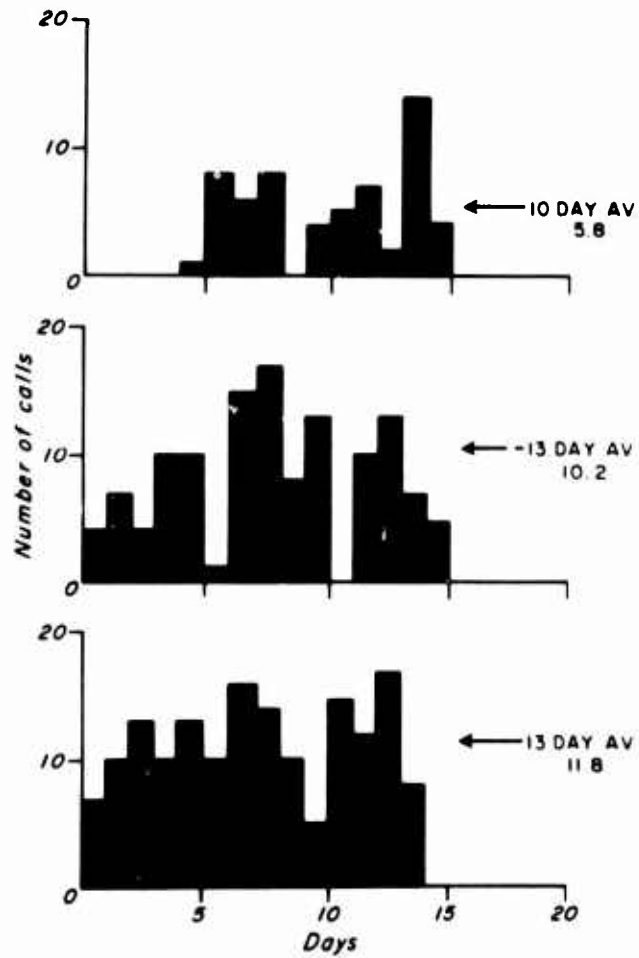

Figure 19. Distribution of telephone calls per day by individual members

A comparison of the two cameras is made in Figure 21. The vertical and radial position of the manipulator was first established by use of camera 1 on the opposite side of the hive, then the manipulator was rotated into the field of view of camera 2. After a considerable number of trial approaches the manipulator hand was engaged in the card slot of one of the spare modulator cards and the card was extracted from its slot. The card was moved down to video 6 module slot and successfully inserted. The engagement of the pins was

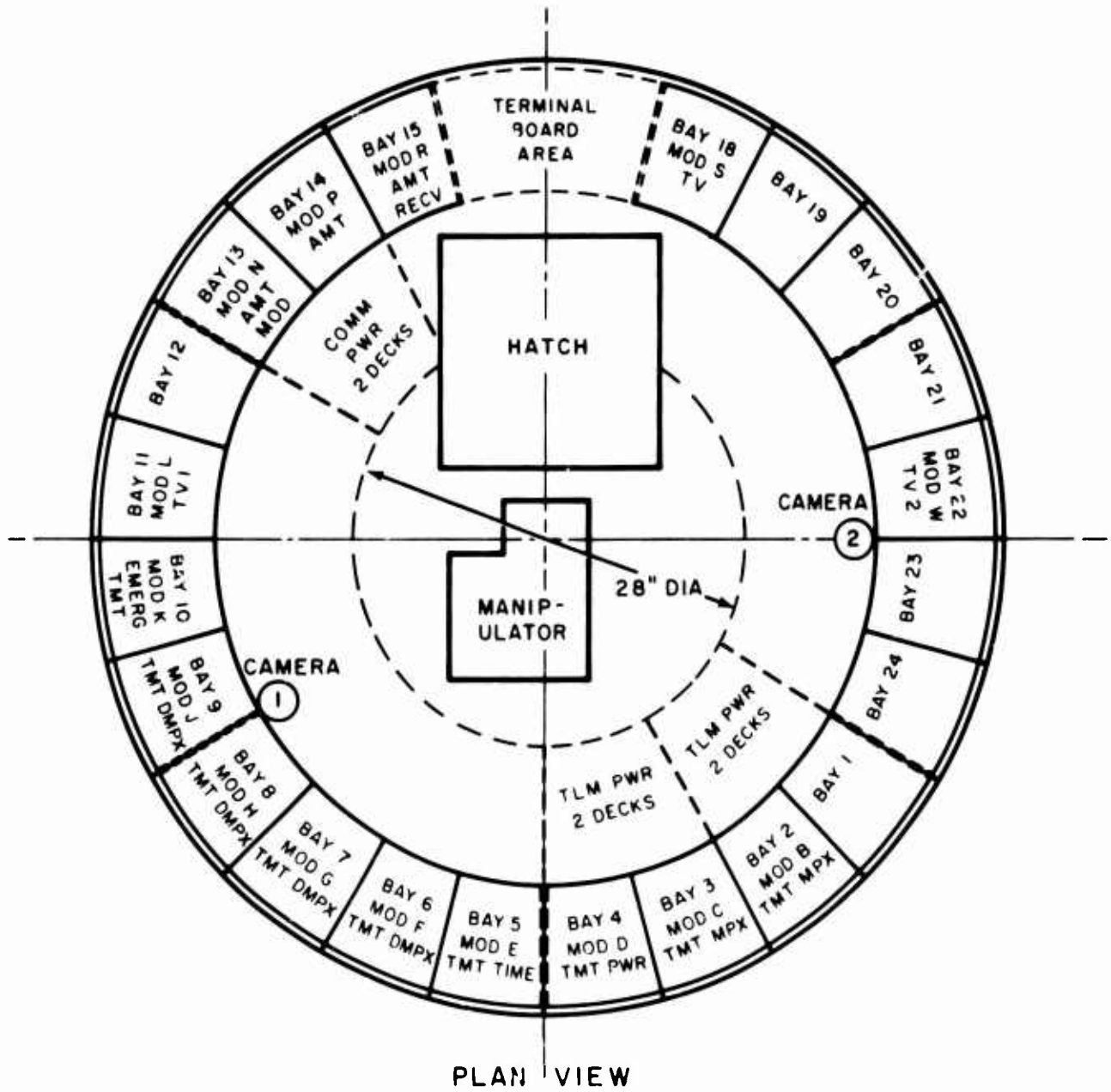

Figure 20. Benthic Lab configuration



Camera 1

Camera 2

Figure 21. Comparison of the resolution of the two Benthic TV cameras

indicated by the occurrence of a strong interference pattern on TV channel 2. The card was then removed from this slot and an attempt made to return it to the storage slot in its original location. At this point considerable difficulty was encountered in aligning the card with the slot as a result of the poor definition of camera 2. In the process of manipulation the card was dropped and lost from view. A cursory examination of the hive with camera 1 did not disclose the final resting place of the card; however, a more careful examination late that night revealed the card might be lodged in the cable harness near the terminal block area (Figure 22). Recovery of the card was considered, but the complete lack of visibility of this area from the camera number 1 vantage point made it virtually impossible and no recovery attempt has been made.

The following day the hydraulic system was checked in an effort to determine the cause of the accidental release of the card from the manipulator jaws. The integrity of the hydraulic lines was investigated by listening to the cavitation of the hydraulic pump through the monitor hydrophones and energizing the negative pressure solenoid for the various functions intermittently. If the pressure had remained the same

in the circuit during the interval of time the solenoid was closed, the flow through the pump would not be changed upon reactivation of the valve. However, if the pressure had relaxed in the circuit, the reduction in pressure when the valve was connected across the manifold would be accompanied by a reduction in the cavitation noise. This reduction of sound was observed on the grip hydraulic circuit after a few seconds delay indicating the presence of a slow leak in the system. In future manipulations this fact was taken into consideration by periodically re-energizing the grip solenoid whenever the grip action was used.

The next manipulation effort attempted was the use of the patch panel to check the performance of the amplitude modulated communication links. In this operation camera 1 was used. Its location between modules 8 and 9 gave an ideal vantage point for the operation on the patch panel board located in module 12. The manipulation was successfully carried out and involved the transfer of both ends of the patch cord. One end was moved to the monitor jack on the upper half of the panel from its original position in the monitor jack on the lower half of the panel (Figure 23).



Figure 22. Terminal block area

The other end of the cord was then inserted in the desired jack in the panel (Figure 24). The jack numbers were marginally readable in this particular area which was in the upper third of the bottom half. The location of the jack was confirmed by counting the jack sequence from a readable number at closer range. During the checking operation it was also necessary to operate the rotary switch in the center of the patch panel (Figures 25a and 25b). In one position of the switch the detent could not be overcome by the wrist rotate motor torque alone and thus it was necessary to stall the wrist rotate and then operate the arm rotate motor to obtain increased torque. Although both functions are driven from identical motors, the loss in the compound gear transmission link, including the worm gear final reduction of the hand rotate function, gives rise to a lower stall torque than the spur gear reduction of the arm rotate function.



Figure 23. Plug-in monitor jack of patch panel



Figure 24. Plug-in jack #59



Figure 25a. Manipulator hand approaching monitor switch



Figure 25b. Manipulator engaged in monitor switch

The major difficulty which was encountered in working with the patch panel was that of releasing a patch cord plug handle once the plug was engaged in its socket. It was somewhat ironic that it at times appeared to be impossible to release the patch cord without pulling the plug from its socket, even though several times during the operation the plug nearly fell off the hand while maneuvering it outside of the socket. It is apparent that a more satisfactory method of engaging objects to be maneuvered is required.

The capability of monitoring the circuits in Benthic is a powerful tool in the Benthic Lab operation. Using this patch panel it was possible to determine the total effect of oil immersion, temperature and pressure on the tuning of three of the receivers and to retune the oscillators in the surface-operating equipment to match the final receiver frequencies. It became apparent that it would be desirable to have even more system voltages and waveforms brought out to the patch panel. In particular, if the voltages of the TV cameras had been available, it would have been possible to determine the cause of the malfunction of camera 2. Also, if all receiver outputs were brought out, a complete system alignment could be carried out.

The first major effort at card replacement in Benthic was undertaken on September 23, in an attempt to rectify difficulties encountered with the A to D converter digital transmission link. On the previous day, measurements taken in SEALAB had indicated an abnormality in data channels 7, 8 and 10. At 10 a.m. on September 23, the manipulator was engaged in the diode matrix card which was located at the extreme bottom of module 3 (Figure 26). The card was extracted part way and released from the manipulator, leaving it disengaged from the connector but still in its slot. The operation took approximately 45 minutes. A second check of the voltages on the A to D converter card socket



Figure 26. Location of faulty card
(bottom of Module 3)

showed that the anomalous voltage readings still existed on channels 7 and 8. Following this test, *SEALAB* was requested to disconnect the plug at the rear of the electronics rack so as to permit measurements to be made on the cable itself. At this point the operations were interrupted by preparation for a dive by the aquanaut assisting in the test, Art Flechsig.

Anticipating that the diode matrix card could be faulty, the manipulator was once again engaged in this card and the card was removed from the slot. The card was brought up close to the TV camera and inspected visually for physical damage, particularly any damage to the card pins. No evidence of physical damage was observed. The card was then moved to a vacant slot in module 4 and partially inserted. Fortunately, before the card was plugged in completely, Bob Cherry recalled that the particular vacant slot was not a storage slot, but was a spare SCR driver card slot, completely wired, with 110 ac appearing on the pins. The card was immediately removed from this slot and a storage slot was located at the top of module 11. This slot was in a very good vantage point from the TV camera and no difficulty was experienced in storing the card in this position.

During this interruption an attempt was made to use the manipulator to move camera 1 to a new location. The engagement slot for the manipulator fingers is located halfway down on the lift bracket in a position which is completely blind from either camera. In order to prepare the camera for lifting it was first necessary to rotate the lift bracket from its stored position at the side of the camera to the forward position. This was accomplished by wedging the fingers between the bolt heads at the top of the bracket and the camera body (visible in Figure 21) and rotating both the wrist pivot and the manipulator rotate function to swing the bracket out into position. The wide range of focus provided in the cameras permits the operator to focus on this operation which takes place only a few inches from the camera lens. Once the lift bracket was rotated into the forward position, the manipulator was retracted into the field of vision of the camera and the arm realigned with the wrist pivot axis vertical, the fingers rotated to the horizontal position and the wrist pointed directly outward in the radial direction. The fingers were then brought up to the top of the lift bracket to obtain a reference measurement on the vertical scale provided on the manipulator. While observing the vertical scale, the arm was dropped 10-3 16" and brought into contact with the lift bracket. The manipulator was positioned so as to maintain a slight pressure on the bracket and the hand then moved up and down until the lifting slot was located by 'feel.'

After locating the slot, the manipulator was extended to fully engage the slot, the jaws opened and the manipulator rotate jogged to center the fingers in the slot to permit full engagement. With the jaws locked in the slot, the TV camera mirror was tilted through the axis of the camera to observe the rear attachment to the module and an attempt was made to lift the camera from its support hook. The attempt was unsuccessful. Although it was possible to raise the camera it was not possible to clear the hook or fully support the camera by the manipulator hand. Apparently either the clamp action was not strong

enough or else the grip function hydraulic leakage was too great to maintain the jaw engagement in the slot. After it was apparent that the camera would not lift free of the support hook, the mirror was rotated back to observe the manipulator and the manipulator was found to be retracted out of contact with the lift bracket. In view of the extremely high risk of dropping the camera under this type of operation further attempts to move the camera were suspended. Approximately one hour was spent in working with the camera in this attempt to reposition it.

At 1230 the aquanaut was available once more to resume testing and a check of the cable at this time indicated that the voltage previously measured on channels 7 and 8 was not present. The plug was re-engaged, a second check made of the voltage at the A to D card socket, and the absence of the voltages confirmed.

At this point the remaining task was to extract the spare card from its position in module 3, five slots down from the top (Figure 27), and insert it in the bottom slot in the same module from which the faulty card had been removed. Unfortunately the vantage point of the camera for the upper slot of module 3 was poor in that the fingers were hidden by the manipulator body. Accordingly in order to extract the card it was necessary to position the manipulator vertically with reference to the fifth card down in module 4 and time the traverse from corresponding points on modules 5 and 4 until a reproducible traverse could be made by timing. The traverse was then timed from the center of the card handle on module 4 to the supposed position of the card handle on module 5. At this point, the manipulator was extended until contact with the card handle was indicated by a slight shift in the position of the module, and the raise-lower function was jogged until the jaws engaged the slot. Next, the manipulator was extended to stall-out, following which it was relaxed slightly by again observing the motion of the module. With the jaw open solenoid actuated, the manipulator rotate function was jogged to center the

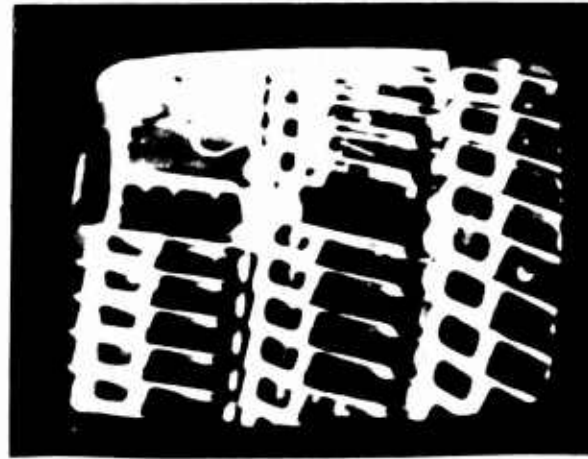

Figure 27. Slot from which spare diode matrix card was extracted

hand in the card handle. By retracting the manipulator slightly, the jaws engaged the notch and locked onto the handle. The card was then extracted. During extraction, the proper alignment of the manipulator was determined by observing the card deflection and jogging the manipulator vertically and radially as indicated to align the card with the slot. Throughout the entire transfer operation the jaw open solenoid was actuated every two to three seconds to be sure that the card would not accidentally be released. While transferring from the number 5 slot to the bottom slot of the module, the wrist was rotated in an upward orientation so that the card could not accidentally drop from the jaws.

Considerable difficulty was experienced in replacing the card in the bottom slot. Visibility conditions were quite poor in that the lighting at the bottom of the module was inadequate for a sharp TV display (Figure 28) and the use of only one camera made it very difficult to estimate distances or orientation of the card at the bottom of the module. A number of tries were required before the card was finally engaged in the slot. Although an accurate measurement of time was not kept on this operation, insertion of the card



Figure 28. Manipulator in position to engage bottom card of Module 3

in this slot required about 20 minutes compared to the two or three minutes required for inserting the faulty card in the top slot of module 11 where visibility conditions were ideal (Figure 29). The card was successfully inserted and homed in place to full-pin contact by the manipulator and the A to D converter card reinstalled in the SEALAB rack. The data transmission link was then found to be operating satisfactorily.

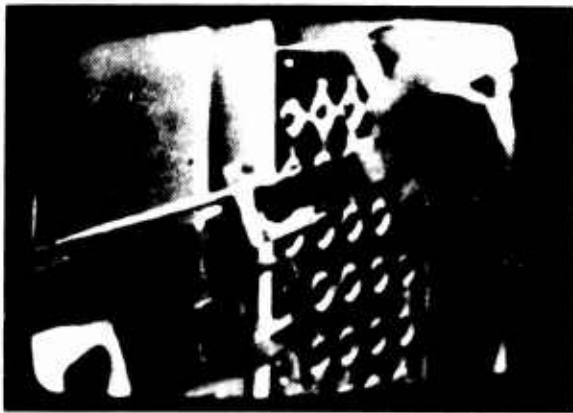

Figure 29. Manipulator in position to engage top card in Module 11

While the cause of the trouble in the A to D link was not conclusively determined, there is a strong suggestion that a combination of electrical leakage in the connector in the SEALAB electronics rack in conjunction with electrical damage to the diode gate card were the cause of trouble and that the trouble was corrected by both the replacement of the card and by the removal of the plug from the chassis socket thereby giving it an opportunity to dry out and relieve the severity of the electrical leakage.

The manipulation experience gained in this limited amount of operating time has been invaluable in indicating the effect of equipment configuration on the performance capability of the Benthic Lab system. The indicated improvements in lighting, camera position and manipulator design may now be incorporated before attempting a deep water installation.

The following Marine Physical Laboratory personnel were involved in the SEALAB project. The list includes all participants in the technical phase of the program and identifies their main area of participation. One quarter of the total effort represents non-premium overtime.

Academic

Anderson, V. C., <i>Acting Director, MPL and Research Physi- cist III</i>	Program direction
Lowenstein, C. D., <i>Assistant Research Physicist I</i>	Computer program for navigation and data recording
Mudie, J. D., <i>Assistant Research Geophysicist I</i>	Site survey, acoustic navigation
Loughridge, M. S., <i>Postgraduate Research Geologist III</i>	Site survey
Nickles, J. C., <i>Research Assistant II</i>	Site survey and in- stallation

Engineering

Gibson, D. K.,
Senior Engineer
Benthic/SEALAB II
electronics and in-
stallation

McGehee, M. S.,
Senior Engineer
Site survey

Cherry, W. R.,
Associate Engineer
Time multiplex elec-
tronics,
Benthic watch

Clay, C. W.,
Assistant Engineer
T.V. design and fab-
rication,
Benthic watch

Mundy, C. S.,
Assistant Engineer
Mechanical fabrica-
tion for underwater
structure

Colburn, C. C.,
Junior Engineer
Digital programmer

Squier, E. D.,
Senior Engineer
Digital programmer

Toller, J. B.,
Junior Engineer
Benthic watch,
Phone patch elec-
tronics

Technical

Boegeman, D. E.,
*Senior Electronics
Technician*
Monitor T.V. modifi-
cation and installa-
tion

Crouch, M. O.,
*Senior Laboratory
Mechanician*
Machine Shop

Denny, G. L.,
*Principal Electronics
Technician*
T.V. design and fab-
rication,
Benthic watch

Donovan, J. T.,
*Senior Marine
Technician*
Diving and installa-
tion

Dunlap, A. S.,
*Principal Laboratory
Mechanician*
Machine Shop

Fiske, R. P.,
Laboratory Helper
General assembly and
assistance

Cainder, J. E.,
Laboratory Mechanician
Machine Shop

Haines, R. B.,
First Officer
Installation and Site
survey,
Liaison and support

Hollaway, D. G.,
*Principal Electronics
Technician*
Plastic encapsula-
tion and console
wiring

Humphrey, H. H.,
*Senior Electronics
Technician*
Audio communica-
tions,
Benthic watch

Lewis, R. P.,
Electronics Technician
General electronics,
Benthic watch

McQuern, H. J.,
Laboratory Mechanician
Mechanical

Marlow, M. S.,
Laboratory Helper
General,
Benthic watch

Miller, S. P.,
Laboratory Helper
Site survey, acoustic
navigation

Mundy, E. R.,
*Senior Laboratory
Mechanician*
Machine Shop

Murphy, D. R.,
Engineering Aid
General electronics,
Benthic watch

Neel, R. P.,
Odd Jobber
Mechanical

Occhiello, L. M.,
Senior Engineering Aid
Electronic assembly,
Control console

Owings, L. G.,
Electronics Technician
Electronic assembly,
Benthic watch

Pawelek, W. D.,
Typist Clerk
General,
Benthic watch

Pecore, N. H.,
Senior Maintenance Man
Remodeling

Ramey, R. E.,
Laboratory Assistant IV
General and Pressure
tests,
Benthic watch

Rinclamer, R. M.,
Electronics Technician
A to D and Communi-
cations assembly,
Benthic watch

Robertson, W. R.,
Engineering Aid
General, Site survey
and acoustic po-
sitioning

Semonchuk, W.,
Laboratory Assistant III
Mechanical, Power
hive and Benthic hive
fabrication

Smith, E. G.,
Electronics Technician
Electronic assembly,
console wiring

Stone, I. W.,
Laboratory Assistant IV
Electronic assembly,
T.V. and console

Truesdale, R. J.,
*Senior Electronics
Technician*
Electronic telemeter-
ing,
Benthic watch

Van Hoy, I. N., <i>Senior Electronics Technician</i>	Electronic telemeter- ing, Benthic watch
Wallingford, R. J., <i>Laboratory Mechanician</i>	Mechanical
Webb, S. G., <i>Senior Laboratory Mechanician</i>	Mechanical
Wittfoht, G. H., <i>Senior Laboratory Mechanician</i>	Machine Shop

Man-months

Academic	10
Engineering	24
Technical	92
TOTAL	126

MPI.—DISTRIBUTION

DISTRIBUTION LIST

Chief of Naval Research
Department of the Navy
Washington, D. C. 20360
Code 406T, Copy 1
Code 416, Copy 2
Code 466, Copies 3-4
Code 467, Copy 5
Code 468, Copy 6-7

Commanding Officer
Office of Naval Research
Branch Office
1030 East Green Street
Pasadena, California 91101
Copy 8

Commanding Officer
Office of Naval Research
Branch Office
Box 39, Navy No. 100
Fleet Post Office
New York, New York 09599
Copy 9

Chief, Bureau of Ships
Department of the Navy
Washington, D. C. 20360
Code 210L, Copy 10
Code 343, Copy 11
Code 1622B, Copy 12-13
Code 1622, Copy 14

Chief of Naval Material
Department of the Navy
Washington, D. C. 20360
PM-4, Copy 15

Chief of Naval Operations
Department of the Navy
Washington, D. C. 20350
Op 03EG, Copy 16
Op 31, Copy 17
Op 32, Copy 18
Op 07C, Copy 19
Op 07T, Copy 20
Op 71, Copy 21
Op 09B5, Copy 22
Op 93R, Copy 23
Op 95, Copy 24

Director, Special Projects
Department of the Navy
Washington, D. C. 20360
SP-2031, Copy 25

Director
Defense Research and
Engineering, The Pentagon
Washington, D. C. 20301
Asst. Director (Undersea
Warfare and Battle Support
System), Copy 26

Weapons Systems Evaluation Group
400 Army-Navy Drive
Arlington, Virginia 22202
Mr. A. M. Bottoms, Copy 27

Assistant Secretary of the Navy
(Research and Development)
Department of the Navy
Washington, D. C. 20350
Copy 28

Chief, Bureau of Naval Weapons
Department of the Navy
Washington, D. C. 20360
Code RU, Copy 29
Code RUDC, Copy 30

Commander Operational
Test and Evaluation Force
U. S. Naval Base
Norfolk, Virginia 23511
Copy 31

Commander, Submarine Force
U. S. Atlantic Fleet
Norfolk, Virginia 23511
Copy 32

Deputy Commander
Submarine Force
U. S. Atlantic Fleet
U. S. Naval Submarine Base
New London
Groton, Connecticut 06342
Copy 33

Commander
Submarine Force
U. S. Pacific Fleet
Fleet Post Office
San Francisco, California 96601
Copy 34

Commander
Submarine Flotilla ONE
Fleet Station Post Office
San Diego, California 92135
Copy 35

Commander
Anti-Submarine Warfare Force
U. S. Atlantic Fleet
Norfolk, Virginia 23511
Copy 36

Commander
Anti-Submarine Warfare Force
Pacific, FPO, Navy No. 128
San Francisco, California 96614
Copy 37

Commander, Submarine
Development Group TWO
Fleet Post Office
New York, New York 09501
Copy 38

Commander, Cruiser-
Destroyer Force
U. S. Atlantic Fleet
Newport, Rhode Island 02840
Copy 39

Commander, Cruiser-
Destroyer Force
U. S. Pacific Fleet
San Diego, California 92132
Copy 40

Commander, Destroyer Development
Group, Pacific
U. S. Naval Station
Long Beach, California 90802
Copy 41

Commander, Destroyer Development
Group TWO
Fleet Post Office
New York, New York 09501
Copy 42

Deputy Commander
Operational Test and Evaluation
Force, Pacific
U. S. Naval Air Station
North Island
San Diego, California 92135
Copy 43

Commander, Key West Test and
Evaluation Detachment
Operational Test and Evaluation
Force
Key West, Florida 33040
Copy 44

Commanding Officer & Director
David Taylor Model Basin
Washington, D. C. 20007
Copy 45

Commanding Officer
U. S. Naval Air Development Center
Johnsville, Pennsylvania 18974
Copy 46

Commanding Officer & Director
U. S. Navy Electronics Laboratory
San Diego, California 92152
Copy 47

Commanding Officer & Director
U. S. Marine Engineering Laboratory
Annapolis, Maryland 21402
Copy 48

Commanding Officer & Director
U. S. Navy Mine Defense Laboratory
Panama City, Florida 32402
Copy 49

Commander
U. S. Naval Ordnance Laboratory
White Oak
Silver Spring, Maryland 20910
Code R, Copy 50
John Munson, Copy 51

Systems Analysis Group
Undersea Warfare Research and
Development Council, Room 5-224
U. S. Naval Ordnance Laboratory
White Oak
Silver Spring, Maryland 20910
Copy 52

MPL—DISTRIBUTION

Commander
U. S. Naval Ordnance Test Station
China Lake, California 93557
Tech Library, Copy 53

Officer in Charge
Pasadena Annex
U. S. Naval Ordnance Test
Station
3203 E. Foothill Boulevard
Pasadena, California 91107
Copy 54

Director
U. S. Naval Research Laboratory
Washington, D. C. 20390
Code 2027, Copies 55-60
Code 5550, Copy 61

Commanding Officer
U. S. Navy Underwater Ordnance
Station
Newport, Rhode Island 02844
Copy 62

Commanding Officer & Director
U. S. Naval Training Device Center
Port Washington, New York 11050
Copy 63

Commanding Officer & Director
U. S. Naval Applied Science
Laboratory
U. S. Naval Base
Brooklyn, New York 11251
Copy 64

Commanding Officer & Director
U. S. Navy Underwater Sound
Laboratory, Fort Trumbull
New London, Connecticut 06321
Code 900, Copy 65
Code 905, Copy 66
Code 910, Copy 67
Code 930, Copy 68
Code 960, Copy 69

Director
U. S. Navy Underwater Sound
Reference Laboratory
P.O. Box 8337
Orlando, Florida 32806
Copy 70

Superintendent
U. S. Naval Postgraduate School
Monterey, California 93940
Librarian, Copy 71

Commander
U. S. Naval Oceanographic Office
Washington, D. C. 20390
Copy 72

Director
Defense Documentation Center
(TIMA), Cameron Station
5010 Duke Street
Alexandria, Virginia 22314
Copies 73-92

Executive Secretary
Committee on Undersea Warfare
National Academy of Sciences
2101 Constitution Avenue, N.W.
Washington, D. C. 20418
Copy 93

Supreme Allied Commander
U. S. Atlantic Fleet
ASW Research Center
APO No. 19
New York, New York 09019
Via: ONR 466
CNO Op 92C2
Secretariat of Military
Information Control
Committee
Copy 94

Director of Naval Warfare Analyses
Institute of Naval Studies
545 Technology Square
Cambridge, Massachusetts 02139
Copy 95

Dr. Frederick V. Hunt
222 Lyman Laboratory
Harvard University
Cambridge, Massachusetts 02138
Copy 96

Director
Hudson Laboratories
145 Palisade Street
Dobbs Ferry, New York 10522
Copy 97

Library
Lamont Geological Observatory
Columbia University
Palisades, New York 10964
Copy 98

Director
Ordnance Research Laboratory
Pennsylvania State University
University Park, Pennsylvania 16801
Copy 99

Director,
University of Texas
Defense Research Laboratory
P.O. Box 8029
Austin, Texas 78712
Copy 100

Director
Applied Physics Laboratory
University of Washington
1013 East 40th Street
Seattle, Washington 98105
Copy 101

Institute for Defense Analyses
400 Army Navy Drive
Arlington, Virginia 22202
Copy 102

Director
Woods Hole Oceanographic Institution
Woods Hole, Massachusetts 02543
Copy 103

University of California, San Diego
Scripps Institution of Oceanography
La Jolla, California 92037
Director, Copies 104-105
For Contributions
S & E Library, Copy 106
Academic Archives
A.P.L. Branch Office, Copy 107
Spec. Dev., Copy 108

National Science Foundation
Washington, D. C. 20550
Copies 109-112

Office of Naval Research
Department of the Navy
Washington, D. C. 20360
Mr. H. A. O'Neal, Code 467
Copies 113-162

DOCUMENT CONTROL DATA - R&D

(Security classification of title, body of abstract and indexing annotation must be entered when the overall report is classified)

1. ORIGINATING ACTIVITY (Corporate author) Marine Physical Laboratory		2a. REPORT SECURITY CLASSIFICATION Unclassified	
		2b. GROUP	
3. REPORT TITLE MPL PARTICIPATION IN SEALAB			
4. DESCRIPTIVE NOTES (Type of report and inclusive dates) Summary			
5. AUTHOR(S) (Last name, first name, initial) Anderson, Victor C. Loughridge, Michael S. Mudie, John D.			
6. REPORT DATE 1 February 1966		7a. TOTAL NO. OF PAGES	7b. NO. OF PAGES
8a. CONTRACT OR GRANT NO. Nonr 2216 (05)		8a. ORIGINATOR'S REPORT NUMBER(S) SIO Reference 66-3	
b. PROJECT NO.		8b. OTHER REPORT NO(S) (Any other numbers that may be assigned this report) MPL-U-57/65	
c.			
d.			
10. AVAILABILITY/LIMITATION NOTICES Qualified requestors may obtain copies of this report from DDC. Distribution of the document is unlimited: Ref. NAVMATINST 4000.17 No. 5200.20			
11. SUPPLEMENTARY NOTES		12. SPONSORING MILITARY ACTIVITY Office of Naval Research	
13. ABSTRACT This report summarizes the participation of the Marine Physical Laboratory in SEALAB II. It includes the results of the fine-grained, topographic survey of the site, details of and experience with the Benthic Laboratory System, and a summary of shore communication center operations during the program.			

14. KEY WORDS	LINK A		LINK B		LINK C	
	ROLE	WT	ROLE	WT	ROLE	WT

INSTRUCTIONS

1. **ORIGINATING ACTIVITY:** Enter the name and address of the contractor, subcontractor, grantee, Department of Defense activity or other organization (*corporate author*) issuing the report.
- 2a. **REPORT SECURITY CLASSIFICATION:** Enter the overall security classification of the report. Indicate whether "Restricted Data" is included. Marking is to be in accordance with appropriate security regulations.
- 2b. **GROUP:** Automatic downgrading is specified in DoD Directive 5200.10 and Armed Forces Industrial Manual. Enter the group number. Also, when applicable, show that optional markings have been used for Group 3 and Group 4 as authorized.
3. **REPORT TITLE:** Enter the complete report title in all capital letters. Titles in all cases should be unclassified. If a meaningful title cannot be selected without classification, show title classification in all capitals in parenthesis immediately following the title.
4. **DESCRIPTIVE NOTES:** If appropriate, enter the type of report, e.g., interim, progress, summary, annual, or final. Give the inclusive dates when a specific reporting period is covered.
5. **AUTHOR(S):** Enter the name(s) of author(s) as shown on or in the report. Enter last name, first name, middle initial. If military, show rank and branch of service. The name of the principal author is an absolute minimum requirement.
6. **REPORT DATE:** Enter the date of the report as day, month, year; or month, year. If more than one date appears on the report, use date of publication.
- 7a. **TOTAL NUMBER OF PAGES:** The total page count should follow normal pagination procedures, i.e., enter the number of pages containing information.
- 7b. **NUMBER OF REFERENCES:** Enter the total number of references cited in the report.
- 8a. **CONTRACT OR GRANT NUMBER:** If appropriate, enter the applicable number of the contract or grant under which the report was written.
- 8b, 8c, & 8d. **PROJECT NUMBER:** Enter the appropriate military department identification, such as project number, subproject number, system numbers, task number, etc.
- 9a. **ORIGINATOR'S REPORT NUMBER(S):** Enter the official report number by which the document will be identified and controlled by the originating activity. This number must be unique to this report.
- 9b. **OTHER REPORT NUMBER(S):** If the report has been assigned any other report numbers (*either by the originator or by the sponsor*), also enter this number(s).
10. **AVAILABILITY/LIMITATION NOTICES:** Enter any limitations on further dissemination of the report, other than those

imposed by security classification, using standard statements such as:

- (1) "Qualified requesters may obtain copies of this report from DDC."
- (2) "Foreign announcement and dissemination of this report by DDC is not authorized."
- (3) "U. S. Government agencies may obtain copies of this report directly from DDC. Other qualified DDC users shall request through _____."
- (4) "U. S. military agencies may obtain copies of this report directly from DDC. Other qualified users shall request through _____."
- (5) "All distribution of this report is controlled. Qualified DDC users shall request through _____."

If the report has been furnished to the Office of Technical Services, Department of Commerce, for sale to the public, indicate this fact and enter the price, if known.

11. **SUPPLEMENTARY NOTES:** Use for additional explanatory notes.
12. **SPONSORING MILITARY ACTIVITY:** Enter the name of the departmental project office or laboratory sponsoring (*paying for*) the research and development. Include address.
13. **ABSTRACT:** Enter an abstract giving a brief and factual summary of the document indicative of the report, even though it may also appear elsewhere in the body of the technical report. If additional space is required, a continuation sheet shall be attached.

It is highly desirable that the abstract of classified reports be unclassified. Each paragraph of the abstract shall end with an indication of the military security classification of the information in the paragraph, represented as (TS), (S), (C), or (U).

There is no limitation on the length of the abstract. However, the suggested length is from 150 to 225 words.

14. **KEY WORDS:** Key words are technically meaningful terms or short phrases that characterize a report and may be used as index entries for cataloging the report. Key words must be selected so that no security classification is required. Identifiers, such as equipment model designation, trade name, military project code name, geographic location, may be used as key words but will be followed by an indication of technical context. The assignment of links, roles, and weights is optional.