

AD630872

RADC-TR-66-125, Vol I



HIGH GAIN ANTENNA TECHNIQUES
System Gain-to-Noise Temperature Ratio Measurements
On An Adaptively Phased Array

Delmer D. Hayes

TECHNICAL REPORT NO. RADC-TR-66-125, Vol I
March 1966

Distribution of this document is unlimited

7.60 0.75 78 02

Code 1

Communications Research Branch
Rome Air Development Center
Research and Technology Division
Air Force Systems Command
Griffiss Air Force Base, New York

When US Government drawings, specifications, or other data are used for any purpose other than a definitely related government procurement operation, the government thereby incurs no responsibility nor any obligation whatsoever; and the fact that the government may have formulated, furnished, or in any way supplied the said drawings, specifications, or other data is not to be regarded, by implication or otherwise, as in any manner licensing the holder or any other person or corporation, or conveying any rights or permission to manufacturer, use, or sell any patented invention that may in any way be related thereto.

The material contained in this report is also used as a Thesis submitted to the Department of Electrical Engineering, The Ohio State University as partial fulfillment for the Degree Master of Science.

Do not return this copy. Retain or destroy.

HIGH GAIN ANTENNA TECHNIQUES
System Gain-to-Noise Temperature Ratio Measurements
On An Adaptively Phased Array

Delmer D. Hayes

Distribution of this document is unlimited

FOREWORD

This interim technical report has been prepared under Contract No. AF30(602)-3601 by The Antenna Laboratory, Ohio State University Research Foundation, 1320 Kinnear Road, Columbus, Ohio 43212. The work was performed under Project 4519, Task 451901. The RADC Project Monitor is Mr. James W. Bailey, EMCRR. The report is identified by the contractor as Report No. 1963-1.

This technical report has been reviewed and is approved.

Approved:

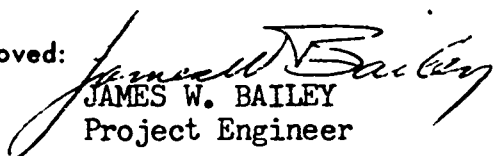
JAMES W. BAILEY
Project Engineer

Approved:

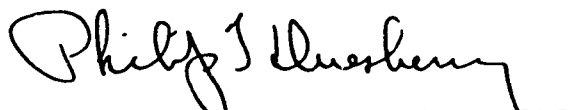
PHILIP T. DUESBERRY, Lt Col, USAF
Chief, Comms Research Branch
Communications Division

ABSTRACT

Factors affecting the ultimate sensitivity of a typical microwave receiving system are discussed. It is shown that the receiver noise-temperature and antenna gain-to-noise-temperature ratio are the dominating parameters which determine the system capabilities. The gain-to-noise temperature ratio is used as a figure-of-merit for the individual channel.

The techniques used to measure the receiver noise temperature, antenna gain, and antenna noise temperature of the four receiving systems at The Ohio State University Antenna Laboratory Satellite Communication Center are presented, along with the results of the measurements.

An expression for the gain-to-noise temperature ratio of the array is developed and shown to be equivalent to an improvement, or enhancement, factor operating on the gain-to-noise temperature ratio of an individual element. The effects of system parameter variations on the array gain-to-noise temperature ratio are studied, and typical values of the enhancement factor are calculated using the measured values of antenna gain and system noise temperatures. Measurements on the Ohio State University array have produced actual enhancement factors of 5.3 to 5.7 db, which closely approach the theoretical maximum of 6 db.

CONTENTS

Chapter		Page
I	INTRODUCTION.....	1
II	GENERAL.....	2
III	ANTENNA GAIN MEASUREMENTS.....	9
	1. Description of Antenna System	9
	2. Gain Measurement Technique	9
	3. Standard Gain Antenna Calibration	11
	4. Gain Measurement Results	12
IV	NOISE TEMPERATURE MEASUREMENTS....	15
	1. Description of Receiver System	15
	2. Measurement Technique	18
	3. Results of Measurements	21
	4. Antenna Noise-Temperature Measurements	23
	5. Antenna Temperature Measurement Results	25
	6. System Sensitivity	26
V	GAIN-TO-NOISE TEMPERATURE RATIO OF ARRAY.....	28
	1. General	28
	2. Signal-to-Noise Ratio of Sum Channel	29
	3. Enhancement Factor of Array	36
	4. Calculated Values of Enhancement Factor	38
VI	EFFECTS OF SYSTEM PARAMETER VARIATIONS.....	42
	1. Phase Jitter	42
	2. Signal-Amplitude Variations	44
	3. Excessive Noise Power	47
	4. Unequal Voltage Gains	49
	5. Effect of Partially Correlated Noise	51

CONTENTS (Continued)

Chapter		Page
VII	TABULATED VALUES OF GAIN-TO- NOISE TEMPERATURE RATIOS.....	54
VIII	SUMMARY.....	55
	REFERENCES.....	57
Appendix		
A	ARRAY NOISE TEMPERATURE.....	58
B	OPTIMUM COMBINING FOR DOMINANT SIGNAL OR NOISE.....	65

CHAPTER I INTRODUCTION

The adaptively-phased array at The Ohio State University Antenna Laboratory has been described in detail in other publications.^{1, 2} Briefly, it consists of four individual microwave receiving systems, each utilizing a 30-foot diameter parabolic antenna, whose output signals are phase-locked and added to produce a single output. One of the purposes of the system is to demonstrate that such a technique will produce a resultant single-channel output with a signal-to-noise ratio equal to that produced by a 60-foot diameter antenna. That is, the system is equivalent to one using a single 60-foot antenna, all other factors, such as bandwidth and noise figure, being equal.

The system is presently being used to track the passive satellites Echo I and Echo II, as well as for studies of the surface of the moon. In order to make meaningful statements about the magnitude of the signals received during such operations it is important that all system parameters affecting the signal levels be accurately measured. The purpose of this paper is to present the results of measurements of antenna gain and system noise temperature of each element of the array. Also, the gain-to-noise temperature ratio of the array is studied, and typical values presented.

CHAPTER II GENERAL

A simplified block diagram of a typical microwave receiving system is shown in Fig. 1. The energy received by the antenna is down-converted in frequency by the local-oscillator and mixer, amplified in the IF amplifier, and delivered to an output monitoring circuit, such as a recorder or oscilloscope. The energy collected by the antenna can be undesired, or interference, signals as well as desired signals. Also, internally generated noise will be present at the output terminals. The relative magnitudes of the desired and undesired signals will, in large part, determine the usefulness of the system. A precise measurement of the parameters affecting these magnitudes will not only determine whether the system is functioning properly, but also make possible statements about the absolute level of the signals received.

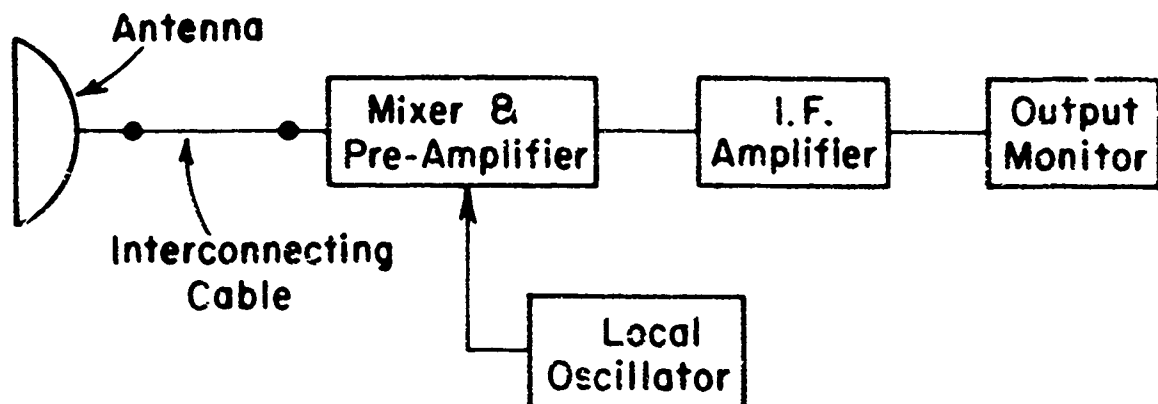

Fig. 1. Simplified microwave receiver system.

The relative importance of the various system parameters can be seen by studying the signal-to-noise ratio at the output circuits, as follows. The Ohio State University system operates as a bi-static radar, in which the transmitter and receiver installations are at separate geographical sites. The amount of signal power collected by the receiver antenna is given by the familiar radar equation,

$$(1a) \quad S_i = \frac{P_T G_T G_R \sigma \lambda^2}{(4\pi)^3 R_1^2 R_2^2},$$

where

S_i = signal power received by antenna,

P_T = transmitter output power,

G_T = transmitter antenna gain,

G_R = receiver antenna gain,

σ = radar echo area of target,

λ = operating wavelength,

R_1 = range to target from transmitter, and

R_2 = range from target to receiver.

It is obvious, of course, that a variation of any of the parameters in Eq. (1a) would affect signal level. However, since the intent of this article is to present a study of the effects of the receiving system alone, it will be assumed that all parameters are constant except the antenna gain. Thus, for fixed ranges,

$$(1b) \quad S_i = \left[\frac{P_T G_T \sigma \lambda^2}{(4\pi)^3 R_1^2 R_2^2} \right] G_R$$

$$= K_S G_R,$$

where

K_S = constant, depending on transmitter and target parameters.

From this it is seen that received signal power varies linearly with the receiver antenna gain.

As was stated above, the antenna delivers desired as well as undesired signals to the receiver. This undesired power can be caused by radiation from stellar sources such as the sun, moon, and radio stars; from emission by water vapor in the atmosphere; and thermal radiation from the Earth, as well as man-made interference. Basically, the noise power per unit bandwidth received by the antenna is

$$(2) \quad \frac{N_i}{B} = \frac{1}{2} A_{em} \int \int \int P(\theta, \phi) U(\theta, \phi) d\Omega,$$

where

N_i = noise power delivered by antenna, watts;

$P(\theta, \phi)$ = power density distribution watts/m²/deg²/cps;

$U(\theta, \phi)$ = normalized antenna pattern, (dimensionless),

$$U(0, 0) = 1;$$

A_{em} = maximum effective aperture of antenna (meters squared);

θ = elevation angle;

ϕ = azimuth angle;

$d\Omega = \sin \theta d\theta d\phi$ = element of solid angle (deg^2); and

B = receiver **bandwidth**, cps.

The factor of one-half enters into Eq. (2) since it is assumed that the radiation is incoherent and unpolarized. If the received power included polarized radiation, it would be weighted by the relative polarizations of the antenna and the source.

If the noise-source spatial distribution and the antenna power pattern are accurately known, including the side and backlobe structure, then Eq. (2) could be used to determine the output from the antenna. However, both of these functions are complex in nature and difficult to measure accurately. Equation (2) serves primarily to define the concept of an antenna having an output when there are supposedly no signals present and leads directly to the concept of antenna temperature.

Antenna temperature, rigorously defined, is given by

$$(3) \quad T_a = \frac{\int_0^{2\pi} \int_0^{\pi} T_b(\theta, \phi) U(\theta, \phi) d\Omega}{\int_0^{2\pi} \int_0^{\pi} U(\theta, \phi) d\Omega} ,$$

where $T_b(\theta, \phi)$ = brightness temperature distribution. The brightness temperature distribution is analogous to the noise-power density

distribution $P(\theta, \phi)$ of Eq. (4). The denominator of Eq. (3) is often referred to as the beam solid angle of the antenna.

Antenna temperature can be conveniently expressed by assuming that the noise power given by Eq. (2) originates in a matched resistor at temperature T_a located at the receiver input terminals. That is, the antenna is considered replaced by a matched resistor at temperature T_a , and the equivalent input noise power is then given by

$$(4) \quad N_i = \left[\frac{1}{2} A_{em} \int \int \int P(\theta, \phi) U(\theta, \phi) d\Omega \right] B$$

$$= KT_a B,$$

where

K = Boltzmann's constant = 1.38×10^{-23} joules/°K;

T_a = antenna temperature, or temperature of equivalent matched resistor, °K; and

B = narrowest bandwidth of receiver.

The signal-to-noise ratio at the input to the receiver can now be expressed as

$$(5) \quad \frac{S_i}{N_i} = \left[\frac{K_s}{KB} \right] \left(\frac{G_R}{T_a} \right).$$

Equation (5) explicitly demonstrates the dependence of the input signal-to-noise ratio on the antenna gain-to-noise temperature ratio, and not

on the antenna gain alone. The point is, both antenna gain and antenna noise temperature are functions of antenna pattern, and to optimize the input signal-to-noise ratio the pattern must optimize the gain-to-noise temperature ratio and not simply maximize the gain.

The output signal power from the receiver is simply

$$(6) \quad S_o = A_R S_i \\ = A_R (K_S G_R),$$

where

S_o = signal power output from receiver, and

A_R = receiver power gain.

The output noise power from the receiver is

$$(7) \quad N_o = A_R N_i + N_R \\ = A_R K T_a B + N_R,$$

where N_R = output noise power internally generated. For simplification, it can be assumed that the noise generated internally by the receiver originates in a matched resistor at the receiver input and that the receiver itself adds no noise to signals being amplified by it.

Thus, the output noise power is

$$(8a) \quad N_o = A_R K T_a B + A_R K T_R B,$$

where T_R = temperature of equivalent resistor at receiver input, or

$$(8b) \quad N_o = A_R KB(T_a + T_R) .$$

Henceforth, T_R will be referred to as the receiver noise temperature.

By usual definition,

$$(9) \quad T_R = 290(F-1),$$

where F = receiver noise factor. The signal-to-noise ratio at the receiver output can now be expressed as

$$(10a) \quad \frac{S_o}{N_o} = \frac{A_R(K_s G_R)}{A_R KB(T_a + T_R)}$$

or,

$$(10b) \quad \frac{S_o}{N_o} = (\text{Constant}) \frac{G_R}{B(T_a + T_R)} .$$

The receiving system parameters that affect the signal-to-noise ratio are thus seen to be the receiver bandwidth and noise figure, and the antenna gain and noise temperature. Until recent years, the receiver noise figure was large with respect to usual antenna temperatures, and the temperature term in the denominator of Eq. (10) was essentially just the receiver noise temperature. Thus, to increase the signal-to-noise ratio one needed only to increase antenna gain.

However, with the introduction of low-noise receivers such as masers and parametric amplifiers, typical receiver noise temperatures were reduced to values of the same order of magnitude as the antenna temperature, which has thus become an important system parameter.

CHAPTER III

ANTENNA GAIN MEASUREMENTS

1. Description of Antenna System

Each of the four antennas in the array has a solid-surface parabolic reflector with a primary feed horn located at the reflector focal point. One of the antennas has a monopulse tracking feed system, which consists of a single square waveguide divided by metal septa to form four square open-ended waveguide horns symmetrically located about a longitudinal axis. To meet the requirements of optimum monopulse patterns, the four guides were made physically smaller than normal, then dielectric loaded to operate above cut-off. The other three feed horns are square air-filled waveguides driving a conventional pyramidal horn with a flare angle of 30° and a five inch-square aperture. All feed-horn outputs come from waveguide-to-coaxial adapters.

2. Gain Measurement Technique

Standard antenna range techniques were employed in the measurement of the antenna characteristics. The test set up is shown in Fig. 2. The standard gain antenna was a three-foot parabola which was carefully calibrated for the measurement. As shown in Fig. 3, this antenna was connected to the support ring which supports the primary

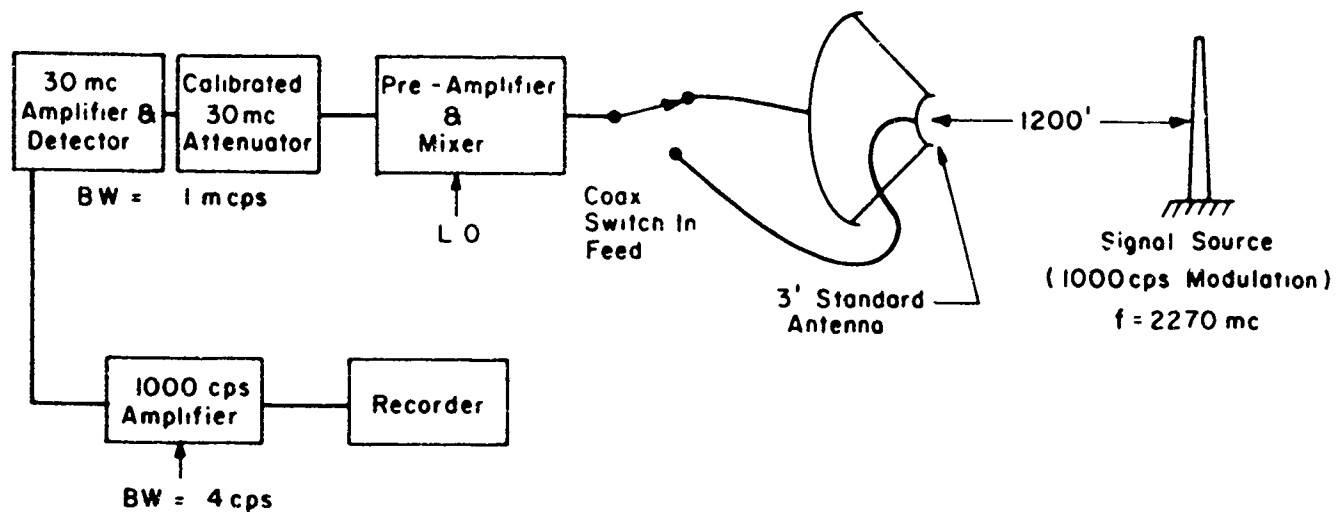

Fig. 2. Gain measurement set-up.

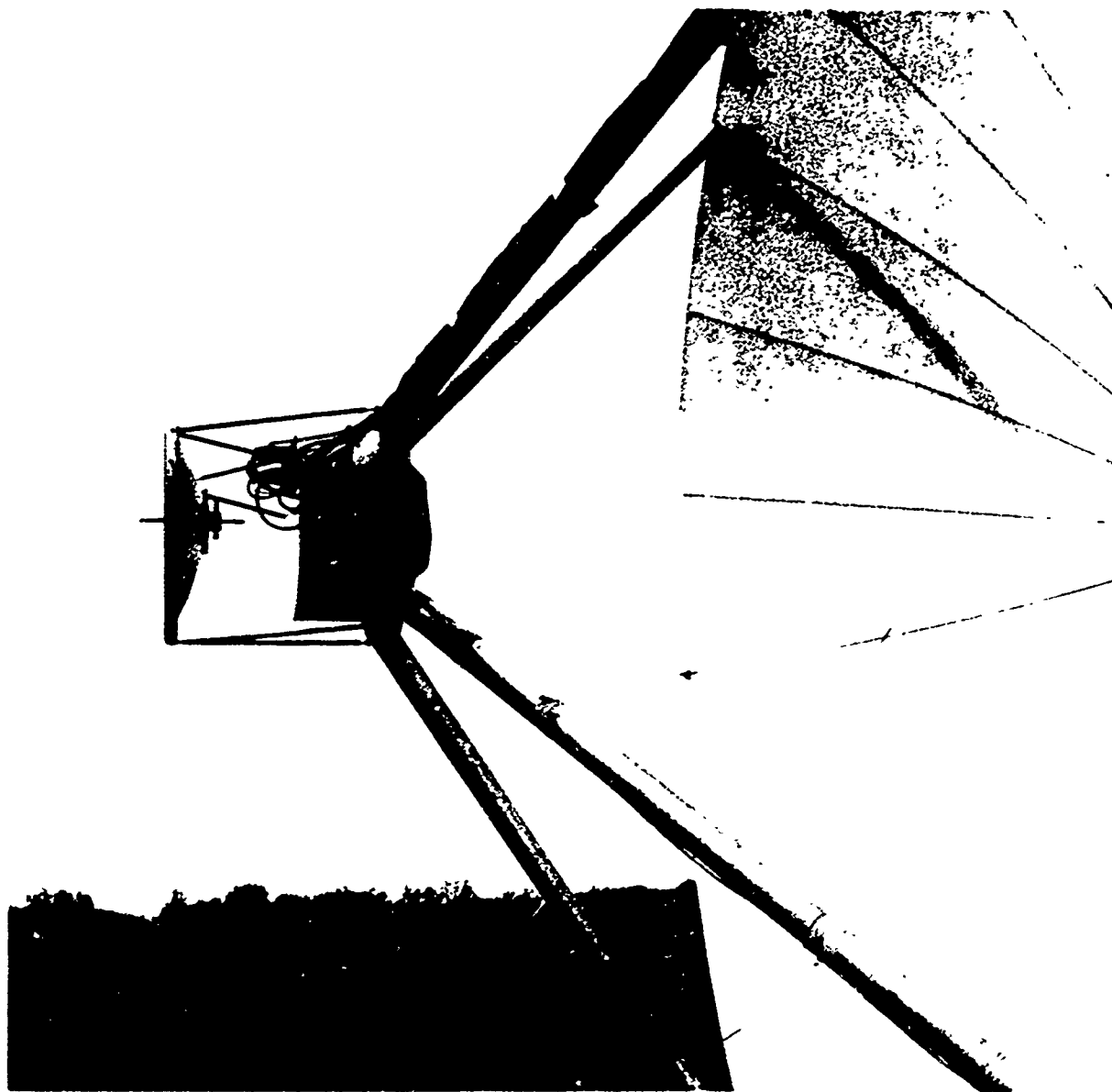

Fig. 3. Photograph of standard-gain antenna mounted on thirty foot antenna.

feed package for the 30-foot antenna so that the center-lines coincided. The two antenna output transmission lines were connected via a coax-switch (operable from the equipment van) to the input of the parametric amplifier normally used with the large antenna. The standard gain antenna was of the same diameter as the feed package, so that no additional aperture blockage resulted from this mounting configuration. The test signal, a 2270 MC source, amplitude-modulated at 1000 cps, was transmitted from a tower approximately 1200 feet away. To measure antenna gain, the test antenna was oriented for maximum response, and the 30 MC attenuator shown in Fig. 2 was adjusted for a convenient reading on the recorder. After recording this level, the standard-gain antenna was switched in, antenna positioning checked, and the attenuator adjusted for the same recorder deflection as was obtained before. The difference in attenuator settings corresponded to the difference in the gain of the two antennas.

3. Standard Gain Antenna Calibration

The absolute gain of the standard antenna was determined by the Absolute Method³ in which two identical antennas are used as a transmitter and receiver. By measuring the ratio of received to transmitted power at a known separation distance, R , the gain of either antenna can be calculated from

$$(11) \quad G_o = \frac{4\pi R}{\lambda} \sqrt{\frac{W_R}{W_t}},$$

where

G_o = absolute gain of either antenna,

R = distance between antennas,

λ = free space wavelength at operating frequency, and

$\frac{W_R}{W_t}$ = ratio of received to transmitted power.

The gain of the standard was measured to be

$$G_{os} = 23 \pm 0.2 \text{ db above isotropic.}$$

The gains of the two antennas used in the calibration were found to be within ± 0.1 db of each other, by comparing each with a third antenna.

4. Gain Measurement Results

Using the technique described above, the measured gains of the antennas were found to be as follows:

$$\text{Monopulse Tracking Antenna Gain} = 42.0 \pm 0.5 \text{ db} = (2.0 \pm 0.2) \times 10^4$$

$$\text{Slave Antenna Gain} = 43.0 \pm 0.5 \text{ db} = (1.59 \pm 0.2) \times 10^4$$

The reduced gain in the monopulse antenna results from losses in the feed horn, feed lines from the horn to the monopulse comparator, and in the comparator itself.

The commonly accepted minimum distance for far-field pattern measurements is given by

$$(12) \quad D = \frac{2d^2}{\lambda},$$

where

D = minimum far field distance,

d = diameter of antenna, and

λ = operating wave length.

The distance between antenna and signal source for these measurements was fixed by geographical location of the antenna site and available towers for use as a signal transmitting site. This distance is approximately one-third the distance given by Eq. (12). However, it is estimated that this factor produces less than five per cent error in the measured results.

Using the measured values of gain, the effective aperture can be determined. The effective aperture and on-axis gain of an antenna are related by

$$(13) \quad A_e = \frac{\lambda^2}{4\pi} G_o,$$

where

G_o = on-axis gain relative to isotropic antenna,

A_e = effective aperture of antenna, and

λ = operating wavelength.

It should be understood that effective aperture includes the effects of losses of any type, such as mismatch or attenuation, in the antenna. It relates power delivered to the receiver to power density of the incident wave.

Using the measured values of gain given above, at a frequency of 2270 MC, the effective apertures are

$$(14a) \quad A_e(\text{monopulse}) = \frac{(0.434)^2 (1.59) (10^4)}{4\pi} = 238 \text{ FT}^2$$

and

$$(14b) \quad A_e(\text{slave}) = \frac{(0.434)^2 (2.0) (10^4)}{4\pi} = 300 \text{ FT}^2.$$

The physical aperture of the 30-foot dishes is 706 FT².

Aperture efficiency, defined as effective aperture over physical aperture, is

$$(15a) \quad \eta_m = \frac{238}{706} \times 100 = 34\%$$

and

$$(15b) \quad \eta_s = \frac{300}{706} \times 100 = 43\%.$$

The additional losses in the monopulse system thus manifest themselves as reductions of aperture size.

For comparison purposes, if the aperture were uniformly illuminated and the antenna were lossless, the gain (maximum) would be

$$(16) \quad G_o(\text{max})_{\text{db}} = 10 \log_{10} \frac{(4\pi) (30)^2 (\pi)}{(0.434)^2 (4)} = 46.74 \text{ db.}$$

For acceptable side-lobe levels and noise temperatures, antenna gain figures are typically 3 db less than the maximum value.

CHAPTER IV
NOISE TEMPERATURE MEASUREMENTS

1. Description of Receiver System

As was indicated in Chapter II, it is important that measurements of the noise temperature of the receiver system and antenna be made. The receiving system for each element uses a multiple-conversion superheterodyne technique. As shown in Fig. 4, the

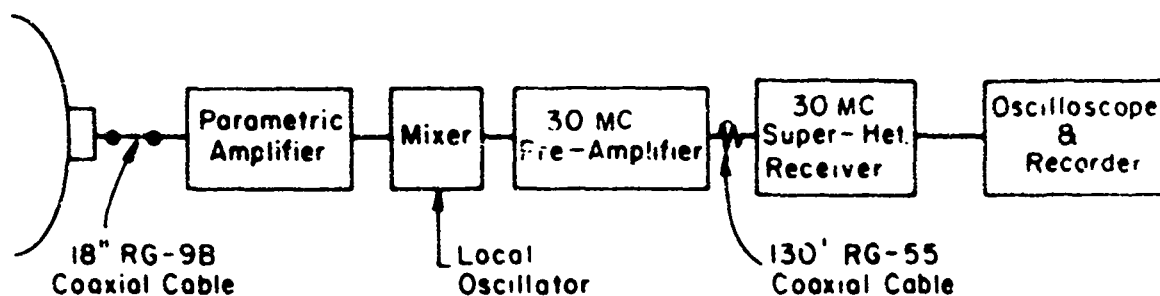

Fig. 4. Block diagram of receiver system.

output of the antenna is connected by coaxial cable to a low-noise parametric amplifier located in a feed package at the focal point of the antenna. This feed package is shown pictorially in Fig. 3. The output of the parametric amplifier is fed into a balanced mixer where it is converted to 30 MC by the injected local oscillator signal. The 30 MC IF signal is then amplified and transmitted over coaxial cable to the equipment van. The 30 MC signal is then again down-converted in the 30 MC receiver, where the 2nd IF is

amplified, phase-locked for summing purposes, and then summed and recorded. In order to measure the noise temperature of such a system it is necessary to understand how the various receiver parameters are related and how they affect the measurement. To do this, consider the generalized block diagram of Fig. 5, where the noise power originating in the matched termination is amplified by several networks in cascade. Also, each stage adds internally generated noise. The input power to the first stage is

$$(17) \quad N_{i1} = KT_0B,$$

where

T_0 = temperature of matched termination, °K,

K = Boltzman's constant, and

B = receiver bandwidth.

The output power of network number one is

$$(18) \quad N_{o1} = N_{i2} = KT_0BG_1 + N_1.$$

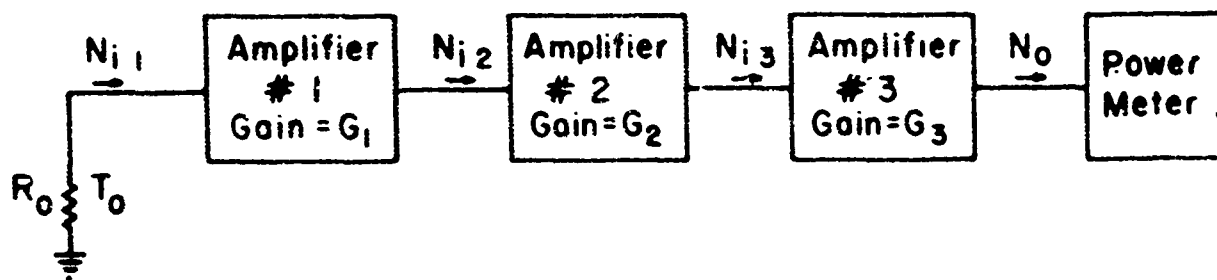

Fig. 5. Effects of cascaded networks on noise temperature.

As was indicated earlier, the factor N_1 is the noise generated internally by amplifier number one, and can be equivalently represented by

$$(19) \quad N_1 = KT_1BG_1,$$

where T_1 = temperature of equivalent input resistor, °K. The output of number one is the input to number two;

$$(20a) \quad N_{O1} = N_{i2} = KBG_1 (T_0 + T_1).$$

Similarly, the output power from amplifiers number two and three is given by

$$(20b) \quad N_{O2} = KBG_1G_2 (T_0 + T_1) + KBT_2G_2$$

and

$$(20c) \quad N_{O3} = KBG_1G_2G_3 (T_0 + T_1) + KBT_2G_2G_3 + KBT_3G_3.$$

Now assume that this noise power output is attributed to an equivalent single amplifying system with the same composite gain, bandwidth, and total internally added excess noise. Then the output noise power would be given by

$$(21) \quad N_0' = N_{O3} = KB(G_1G_2G_3) (T_0 + T'),$$

where T' = effective system noise temperature of the cascaded amplifiers. Equating these two expressions yields

$$(22a) \quad KB(G_1G_2G_3)(T_0 + T') = KBG_1G_2G_3(T_0 + T_1) + G_2G_3KBT_2 \\ + G_3KBT_3$$

or

$$(22b) \quad (T_0 + T') = (T_0 + T_1) + T_2/G_1 + T_3/G_1G_2.$$

If the gains of the first and second stages are sufficiently large, then

$$(22c) \quad T' = T_1;$$

that is, the noise temperature of the complete system is essentially that of the first stage. This fact makes it possible to concentrate the noise figure measurements on the first stage of the receiver, i. e., the parametric amplifier. Specifically, since the gain of the parametric amplifier is approximately 100 (20 db) and the composite gain of the mixer and 30 MC preamplifier is 10,000 (40 db), the system noise temperature is essentially that of the parametric amplifier. Thus, the measurement of this noise temperature can be made at the 30 MC level with the mixer-preamplifier having little effect on the accuracy.

2. Measurement Technique

The standard "Y-factor" technique was used in all noise-temperature measurements. Figure 6 shows the equipment set-up used for this technique. The noise figure meter was located in the equipment van. Operated in its "manual" mode, it served as an accurate 30 MC square-law detector, with recorder output.

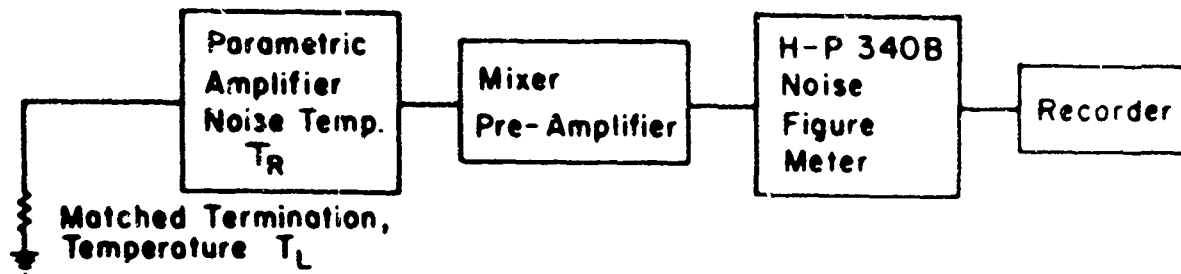

Fig. 6. Set-up for parametric amplifier noise temperature measurement.

The loss in the long length of coaxial cable separating the feed package and the noise figure meter had little effect on accuracy since it was effectively eliminated by the gain of the amplifiers in the feed.

The Y-factor technique can be demonstrated as follows: Assume the matched termination is at some "hot" value, T_H . The noise-power output from the parametric amplifier is

$$(23) \quad N_{OH} = GKT_H B + GKT_R B = GKB(T_H + T_R),$$

where

N_{OH} = output noise power when termination is T_H ,

T_H = temperature of termination when hot,

T_R = equivalent noise temperature of receiver, or
parametric amplifier,

G = total gain through channel, and

B = most narrow bandwidth through channel.

The output noise power when the termination is "cold" is, similarly,

$$(24) \quad N_{Oc} = GKT_c B + GKT_R B = GKB(T_c + T_R),$$

where T_c = temperature of termination when "cold." Let the deflection of the noise figure meter due to N_{oH} be D_H , and due to N_{oc} be D_c . The ratio of these two readings is

$$(25) \quad \frac{D_H}{D_c} = Y = \frac{GKB(T_H + T_R)}{GKB(T_c + T_R)} = \frac{(T_H + T_R)}{(T_c + T_R)} .$$

Thus, if the two temperatures, T_H and T_c , are known, the receiver noise temperature can be found from

$$(26) \quad T_R = \frac{T_H - YT_c}{(Y - 1)} .$$

The desirability of this technique is readily apparent since only the two temperatures need be known. Of course, the gain must remain constant, but the stability of the equipment was such that this was not a problem.

The hot and cold temperatures for the measurements of the receiver noise temperature were realized by using a commercially available Hot-Cold Noise Source (Airborne Instruments Laboratory model number 7062) which contains two matched terminations. One is in a temperature-controlled oven, the other is immersed in liquid nitrogen. The oven temperature (T_H) is held constant at 373.1°K and the temperature of pure liquid nitrogen at sea level is 77.3°K, or 77.6° at the station elevation. Either termination can be selected

by actuating a coaxial switch incorporated in the device. To make the measurements, the Hot-Cold load was connected to the parametric amplifier input terminals, and the meter deflections noted as the hot load and cold load were alternately selected. Specifically, the noise-figure meter provides an output proportional to meter deflection, which was continuously recorded while alternating between the hot and cold loads such that an average Y-factor could be determined. Since the feed package containing the parametric amplifier is exposed to a wide range of environmental conditions, the measurements were repeated over a period of time to determine the spread in experimental values.

3. Results of Measurements

The measured values of the four parametric amplifiers are given in Table I. Each of the four units is referred to by the geographic orientation of the particular antenna in which it is located. It should be noted that the values stated for T_H and T_C , that is, 373.1°K and 77.6°K, are not the actual values used in calculating the noise temperatures. In order to connect the output of the Hot-Cold Load to the input of the parametric amplifier, a short length of coaxial cable was required. It is well known that a loss in a cable changes the noise temperature of the load according to the expression

$$(27) \quad T'_L = \frac{T_L}{L} + T_o \left(1 - \frac{1}{L}\right),$$

where

T_L = actual temperature of load, °K,

T_o = temperature of the cable, °K,

L = amount of loss in cable ($L \geq 1$), and

T'_L = effective temperature of load, °K.

The cable used in the above measurements had a loss of

$$L = 0.45 \pm 0.05 \text{ db.}$$

For a cable temperature of 300°K, the effective temperatures of the

hot and cold loads were

$$(28a) \quad T'_H = \frac{373.1}{1.11} + 300 \left(1 - \frac{1}{1.11}\right) = 365^\circ\text{K}$$

and

$$(28b) \quad T'_c = \frac{77.6}{1.11} + 300 \left(1 - \frac{1}{1.11}\right) = 100^\circ\text{K}.$$

TABLE I
Results of Noise Temperature Measurements

Parametric Amplifier	Noise Temperature			Noise Figure
	Low	High	Average	Average in db
North	271	312	291	3.01
South	255	271	262	2.80
East	415	510	478	4.23*
West	268	300	284	2.97

4. Antenna Noise-Temperature Measurements

To measure the noise temperatures of the antennas the same basic Y-factor technique was used. In this case, the hot load was a matched termination and the cold load was the antenna itself. This is shown in Fig. 7. The coaxial switch shown is a single-pole, four-throw, rotary switch which is an integral part of the operational system. It is controllable from the equipment van and is used to connect the parametric amplifier to the antenna, to a test cable for tuning purposes, and to other functions necessary for the operational check-out of the system. For these measurements, a matched termination was connected

*All parametric amplifiers were designed to have equal noise figures. Damage to the East unit resulted in the higher value shown. This condition has since been corrected.

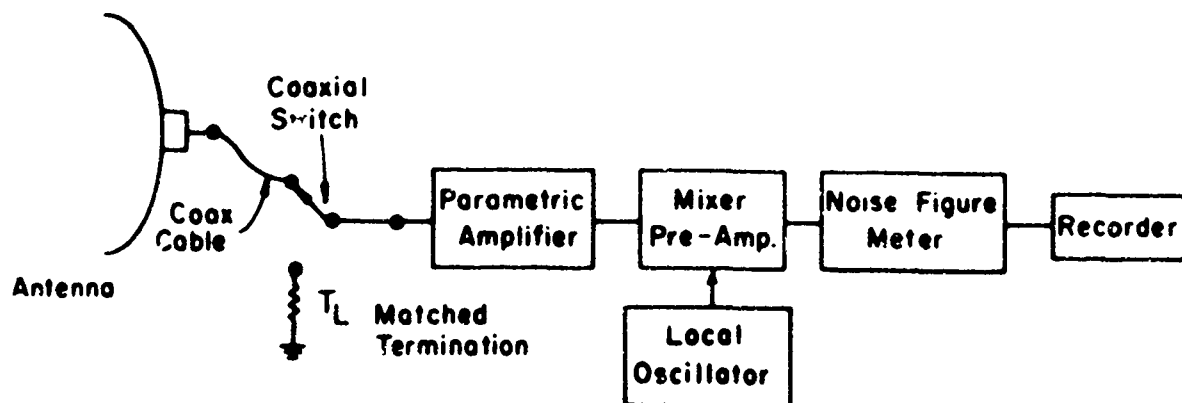

Fig. 7. Technique for measuring antenna temperature.

to one of the switch ports, then the antenna and the load were alternately selected from the equipment van. Since the cables connecting the antenna to the switch and the switch to the parametric amplifier, as well as the switch itself, are lossy, it was actually the effective antenna noise temperature and not the actual value which was measured. That is, from Eq. (27),

$$(29) \quad T_a' = \frac{T_a}{L} + T_o \left(1 - \frac{1}{L} \right),$$

where

T_a' = measured (or effective) value of antenna temperature,

T_a = temperature of antenna without cable losses,

L = loss factor in interconnecting cables and switch, and

T_o = temperature of cables and switch.

The value of L can be determined by direct measurement, and the actual antenna temperature can then be calculated. However, the

knowledge of the actual temperature is somewhat academic since the cables are a necessary part of the operational system. It is the measured value, T_a' , which must enter into any calculations involving system sensitivity or noise temperature.

From Fig. 7, the Y-factor measured as the antenna and the load are alternately selected is given by

$$(30) \quad \frac{(T_L + T_R)}{(T_a' + T_R)} = Y.$$

The factor, T_R , the receiver noise temperature, must be known but has already been given in the previous chapter. The temperature, T_L , of the matched load was determined by measuring the feed-package internal temperature. The effective antenna temperature is thus found from Eq. (30). Or,

$$(31) \quad T_a' = \frac{[T_L - T_R(Y-1)]}{Y}.$$

5. Antenna Temperature Measurement Results

The average results of measurements made on the four antenna noise temperatures are given in Table II. Both the effective temperature which includes cable losses, and the actual temperature, which excludes these losses, are given.

TABLE II
Results of Antenna Temperature Measurements

Antenna	Antenna Temperature at Zenith	
	Effective	Actual
North	98	52
East	94	45
South	134	95
West	102	54

The accuracy of the measurement of T_a' is better than of T_a , since only the knowledge of the temperature of the drum and the parametric amplifier noise temperature is needed. In order to determine T_a accurately it is also necessary to accurately measure the rather small losses in the feed cables.

6. System Sensitivity

Using the data of Tables I and II, the sensitivity of the receiving systems can be calculated. In this case, sensitivity is defined as the level of received signal which is equal to the noise power present in the system, referred to the input terminals. This value depends on the antenna noise temperature, receiver noise temperature, and receiver bandwidth, and is given by

$$(32) \quad N_i = KB_N (T_a' + T_R).$$

where

N_i = equivalent input noise power present in system,

B_N = receiver IF-noise bandwidth, and

$B_N = 18$ Kcps.

Using average values from Tables I and II the system sensitivity is

$$(33a) \quad N_i = (1.38 \times 10^{-23})(18 \times 10^3)(285 + 107),$$

$$(33b) \quad N_i = 9.73 \times 10^{-17} \text{ watts, and}$$

$$(33c) \quad = -130.1 \text{ dbm.}$$

CHAPTER V
GAIN-TO-NOISE TEMPERATURE
RATIO OF ARRAY

1. General

In the preceding chapters, e. g., Eq. (10b), it was pointed out that for a given bandwidth, the ultimate usefulness of a channel is determined by its gain-to-noise temperature ratio. Each of the quantities in this ratio are uniquely defined and can be measured by standard techniques. The gain-to-noise temperature ratio is thus seen to be an effective figure-of-merit for the channel and can be used for system calculations and for comparing systems.

Since the primary purpose of the Ohio State University array is to function as an equivalent single-channel system, it is naturally of interest to see if a similar figure-of-merit can be defined for comparison with other systems.

As was done for the single channel in Eq. (10b), the output signal-to-noise power ratio for the array (i. e., the sum channel) will be developed in terms of the parameters of the system. This expression will then be examined in detail and a figure-of-merit defined based on the results of this analysis. It will be seen that, as for the single channel, the array gain-to-noise temperature ratio is an effective way of expressing its ultimate usefulness as a receiving system. The array gain-to-noise temperature ratio,

unlike that of a single channel, is dependent on several parameters of its individual elements and is subject to variations. However, for a given configuration, it is a single quantity that completely describes the possible performance of the array.

2. Signal-to-Noise Ratio of Sum Channel

In Fig. 4 a simplified block diagram for each channel is shown. Where the output is shown going to a recorder, let it be assumed that a parallel output goes to the summing network. Each receiver includes the phase-lock circuitry required for keeping the signals locked in-phase at the input to the summing network. The total system can thus be represented by the block diagram of Fig. 8. The quantities shown

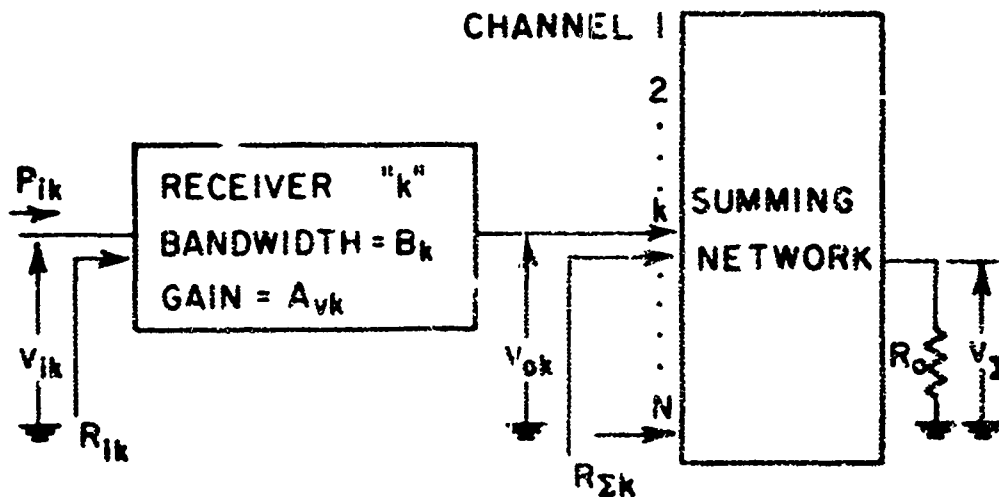

Fig. 8. Simplified multi-channel receiver.

in Fig. 8 are defined as

$$P_{ik} = S_{ik} + N_{ik} = \text{total power input to receiver channel } k, \text{ including signal power and total channel noise power;}$$

- v_{ik} = instantaneous input voltage associated with P_{ik} ;
 R_{ik} = input resistance of channel k receiver;
 v_{ok} = instantaneous output voltage from receiver "k";
 $R_{\Sigma k}$ = input resistance of channel k on summing circuits;
 R_o = output load of summing circuit; and
 v_{Σ} = instantaneous output voltage from summing circuit.

The signal power, S_{ik} , is that delivered from the kth antenna to its respective receiver, after being attenuated by the interconnecting cables. The noise power; N_{ik} , is the total noise power of the kth channel referred to the input; that is,

$$(34) \quad N_{ik} = K B_k (T_{ak} + T_{rk}),$$

where

- K = Boltzman's constant = 1.38×10^{-23} Joules/cps °K,
 B_k = kth channel receiver noise-bandwidth,
 T_{rk} = kth channel receiver noise-temperature, and
 T_{ak} = kth channel antenna noise-temperature.

Referring to Fig. 8, the input and output signal voltages are, respectively,

$$(35) \quad v_{ik} = \sqrt{2S_{ik}R_{ik}} e^{j\theta_k}$$

and

$$(36) \quad \begin{aligned} v_{ok} &= A_{vk} v_{ik} \\ &= A_{vk} \sqrt{2S_{ik} R_{ik}} e^{j\theta_k}, \end{aligned}$$

where

A_{vk} = voltage gain of k th channel from parametric amplifier input to sum channel input and

θ_k = relative phase of k th channel IF with respect to an arbitrary reference.

Since the noise voltage of each channel is a random process, it is not very meaningful to discuss its instantaneous value. A more applicable term is the RMS value of the noise voltage. The RMS noise voltage at each input to the summing circuit is

$$(37) \quad V_{nk} = A_{vk} \sqrt{N_{ik} R_{ik}} = A_{vk} \sqrt{KB_k(T_{ak} + T_{rk}) R_{ik}}$$

To develop an expression for the signal and noise output voltages from the sum channel, it is necessary to know the specific type of summing circuitry used. The summing circuit used with the Antenna Laboratory array is an operational amplifier in a weighted summing configuration, shown in Fig. 9.

The gain, A , is large enough that the output voltage is simply

$$(38) \quad v_{\Sigma} = - \left[\frac{R_f}{R_{\Sigma_1}} v_{01} + \frac{R_f}{R_{\Sigma_2}} v_{02} + \frac{R_f}{R_{\Sigma_3}} v_{03} + \frac{R_f}{R_{\Sigma_4}} v_{04} \right].$$

The large negative feedback used in the amplifier places point P, the junction of the input resistors and feedback resistor, at virtual ground.

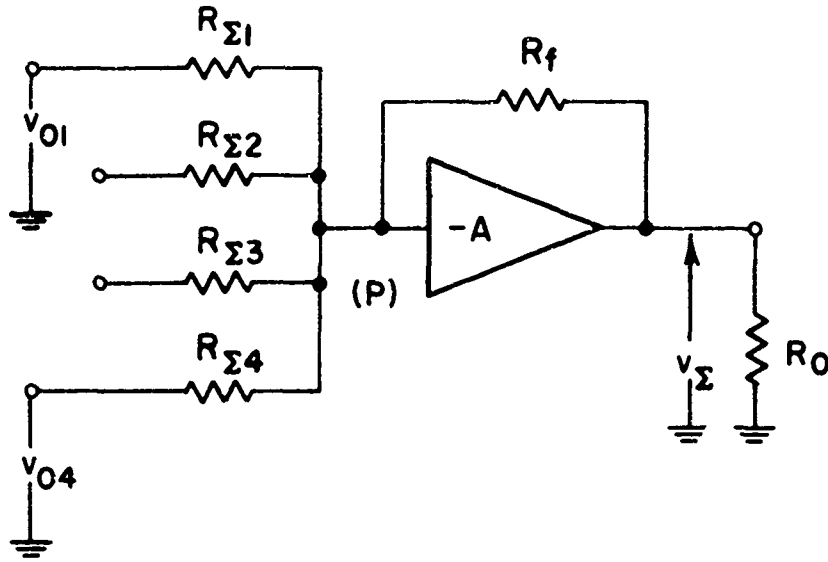

Fig. 9. Summing circuit.

This results in nearly perfect isolation between inputs and makes the input resistance to the k th channel equal to just $R_{\Sigma k}$. Using Eqs. (36) and (38), the signal voltage from the sum channel is

$$\begin{aligned}
 (39) \quad v_{\Sigma} &= A_{v1} \frac{R_f}{R_{\Sigma 1}} \sqrt{S_{i1} R_{i1}} e^{j\theta_1} + A_{v2} \frac{R_f}{R_{\Sigma 2}} \sqrt{S_{i2} R_{i2}} e^{j\theta_2} \\
 &+ \dots + A_{v4} \frac{R_f}{R_{\Sigma 4}} \sqrt{S_{i4} R_{i4}} e^{j\theta_4} \\
 &= R_f \sum_{k=1}^4 \frac{A_{vk}}{R_{\Sigma k}} \sqrt{S_{ik} R_{ik}} e^{j\theta_k}.
 \end{aligned}$$

The output noise voltage from the sum channel is the sum of N random processes and is itself a random process. As in the case of the individual channels, it is best dealt with in terms of its statistics.

The most significant one, the standard deviation, is equivalent to the RMS value of its voltage. This quantity can be measured easily by commercially available, true-RMS-reading voltmeters. However, an analytical expression for this output RMS noise-voltage can be quite complicated. Specifically, the square of the output RMS voltage, proportional to the output noise power, is given by

$$(40) \quad \sigma_{\Sigma}^2 = \sum_{k=1}^N \sigma_k^2 + 2 \sum_{j=1}^N \sum_{i=j+1}^N \mu_{ij} \sigma_i \sigma_j,$$

where

σ_{Σ}^2 = variance of sum output noise process (corresponds to noise power),

σ_k^2 = variance of kth channel noise process,

μ_{ij} = correlation coefficient of ith and jth channels, and

σ_i = standard deviation of ith channel (corresponds to RMS value of noise voltage).

The effectiveness of the array depends on the noise voltages of the various inputs being uncorrelated, so that they tend to cancel each other. The sum channel signal-to-noise ratio will be developed assuming no correlation ($\mu_{ij} = 0$ for $i \neq j$), then the effects of partially correlated noise will be treated separately.

Making this assumption, the sum output RMS noise voltage is, from Eqs. (37), (38), and (40),

$$(41) \quad V_{N\Sigma} = \left[\left(\frac{R_f}{R_{\Sigma_1}} V_{N_1} \right)^2 + \left(\frac{R_f}{R_{\Sigma_2}} V_{N_2} \right)^2 + \left(\frac{R_f}{R_{\Sigma_k}} V_{N_3} \right)^2 + \left(\frac{R_f}{R_{\Sigma_4}} V_{N_4} \right)^2 \right]^{\frac{1}{2}}.$$

The output noise power, in terms of individual channel parameters, is

$$(42) \quad N_{\Sigma} = \frac{V_{N\Sigma}^2}{R_o} = K \frac{R_f^2}{R_o} \sum_{k=1}^4 \left(\frac{AV_k}{R_{\Sigma_k}} \right)^2 B_k R_{ik} (T_{ak} + T_{rk}).$$

The signal-to-noise power ratio of the output of the sum channel can now be expressed directly in terms of Eqs. (39) and (42); that is,

$$\frac{S_{\Sigma}}{N_{\Sigma}} = \frac{V_{S\Sigma}^2/R_o}{V_{N\Sigma}^2/R_o} = \frac{V_{S\Sigma}^2}{V_{N\Sigma}^2},$$

where

$V_{S\Sigma}$ = RMS signal voltage from sum circuit

or,

$$(43) \quad \frac{S_{\Sigma}}{N_{\Sigma}} = \frac{\left[\frac{1}{\sqrt{2}} \left| \sum_{k=1}^4 \frac{AV_k}{R_{\Sigma_k}} \sqrt{2S_{ik}R_{ik}} e^{j\theta_k} \right| \right]^2}{K \sum_{k=1}^4 \left(\frac{AV_k}{R_{\Sigma_k}} \right)^2 B_k R_{ik} (T_{ak} + T_{rk})}.$$

The factor $\sqrt{2}$ in the numerator is necessary to express the magnitude of the sum signal as an RMS value.

Equation (43) is the complete expression for the sum channel signal-to-noise power ratio and assumes only that the noise voltages are uncorrelated. Although this expression is rather complicated some simplifying assumptions can be made. First, the sum circuit input resistors, $R_{\Sigma k}$, were all adjusted for equal values. Secondly, the input resistance of each receiver, R_{ik} , is the input resistance of each parametric amplifier. Since all channels show good VSWR characteristics it may be assumed that all input resistances are equal. With these assumptions, Eq. (43) reduces to

$$(44) \quad \frac{S_{\Sigma}}{N_{\Sigma}} = \frac{\left[\left| \sum_{k=1}^4 A_{V_k} \sqrt{S_{ik}} e^{j\theta_k} \right| \right]^2}{K \sum_{k=1}^4 A_{V_k}^2 B_k (T_{ak} + T_{rk})}$$

The above expression provides considerable insight into the operational requirements placed on the array to properly function as a single-channel system. The maximum signal-to-noise ratio occurs when all four channels are identical and the signals are exactly in phase. That is, if all θ_k 's are equal and the voltage gain, received signal power, and noise power of each channel are equal, then Eq. (44) simplifies to

$$(45) \quad \frac{S_{\Sigma}}{N_{\Sigma}} = \frac{(N A_V \sqrt{S_i})^2}{N A_V^2 K B (T_a + T_r)} = N \left(\frac{S_i}{N_i} \right),$$

where $\frac{S_i}{N_i}$ = signal-noise power ratio of an individual channel.

For the four-element system at the Antenna Laboratory, the maximum improvement is a factor of four, or 6 db. Although there is four times as much noise power in the sum, there is also four times the signal voltage, or sixteen times as much signal power, resulting in a factor of four increase in the signal-to-noise power ratio.

3. Enhancement Factor of Array

It has already been shown through Eq. (10b) that the output signal-to-noise ratio of each channel can be expressed as a function of the gain-to-noise temperature ratio of the channel. In Eq. (45) it is implied that this is also true of the sum signal-to-noise ratio. Specifically, let channel one be chosen (arbitrarily) as a reference. It can also be assumed that θ_1 is zero.

Equation (44) can thus be re-written as

$$(46) \quad \frac{S_{\Sigma}}{N_{\Sigma}} = \frac{S_{i1} \left[\sum_{k=1}^4 \frac{A_{vk}}{A_{v1}} \sqrt{\frac{S_{ik}}{S_{i1}}} e^{j(\theta_k - \theta_1)} \right]^2}{B_1 (T_{a1} + T_{r1}) K \sum_{k=1}^4 \left(\frac{A_{vk}}{A_{v1}} \right)^2 \left(\frac{B_k}{B_1} \right) \frac{(T_{ak} + T_{rk})}{(T_{a1} + T_{r1})}},$$

or, substituting Eq. (10b) into this expression,

$$(47) \quad \frac{S_{\Sigma}}{N_{\Sigma}} = (\text{constant}) \left[\frac{G_{R1}}{(T_{a1} + T_{r1})} \right] \left\{ \frac{\left[\sum_{k=1}^4 \left(\frac{A_{vk}}{A_{v1}} \right) \sqrt{\frac{S_{ik}}{S_{i1}}} e^{j(\theta_k - \theta_1)} \right]^2}{\sum_{k=1}^4 \left(\frac{A_{vk}}{A_{v1}} \right)^2 \left(\frac{B_k}{B_1} \right) \left(\frac{T_{ak} + T_{rk}}{T_{a1} + T_{r1}} \right)} \right\}$$

As in Eq. (10b), the constant term takes into account the specific transmitter and target configuration. The summing process is seen to play the role of an operator on the gain-to-noise temperature ratio of the reference channel. The gain-to-noise temperature ratio of the array can thus be defined as

$$(48a) \quad (G/NT)_{\Sigma} = (G/NT)_{REF} (\text{Enhancement Factor}),$$

where

$$(48b) \quad (\text{Enhancement Factor}) = \frac{\left[\sum_{k=1}^4 \left(\frac{A_{vk}}{A_{v1}} \right) \sqrt{\frac{S_{ik}}{S_{i1}}} e^{j(\theta_k - \theta_1)} \right]^2}{\sum_{k=1}^4 \left(\frac{A_{vk}}{A_{v1}} \right)^2 \left(\frac{B_k}{B_1} \right) \left(\frac{T_{ak} + T_{rk}}{T_{a1} + T_{r1}} \right)}$$

In Eq. (45) it was pointed out that this enhancement factor has a maximum value of N , the number of elements in the array.

It is readily apparent from the above expressions that the array G/NT is not a fixed and unique quantity. It is a function of many variables and cannot be directly measured. However, taking

its optimum value, it provides a figure-of-merit for the array which can be used for direct comparison or calculation purposes.

4. Calculated Values of Enhancement Factor

As typical examples of the variations to be expected in the value of the enhancement factor, consider the results of using the measured values of antenna gain and system temperature of the four elements of the array at The Ohio State University. The measured values are repeated in Table III. The West antenna is seen to have the best gain and system-temperature combination so it will be taken as the reference. Four separate cases will be considered. In all cases, the signal level in the West channel will be used as a reference level and it will be assumed that the input signal levels in the other three channels differ only by the ratio of their antenna gains.

TABLE III
Measured Values of System Parameters
for Antenna Laboratory Array

Description	West	North	East	South
* Receiver noise Temp °K	284	291	+478/300	262
** Effective antenna Temp °K	102	98	94	134
Antenna Gain	43 db	43 db	43 db	42 db
System temperature °K	386	389	572/394	396
Noise power normalized to West	1.0	1.01	1.48/1.02	1.03
Antenna Gain Normalized to West	1.0	1.0	1.0	0.80
Optimum receiver gain for Case III, (normalized to West)	1.0	0.99	0.93	0.87
Optimum receiver gain for Case IV (normalized to West)	1.0	0.99	0.68	0.87

* From Table I

** From Table II

† The higher value was with a malfunction, the lower value is the normal temperature.

CASE 1: Assume that the voltage gains of all channels are equal, and the East antenna has its normal noise temperature. Using values from Table III, the sum-channel signal-to-noise power ratio is, from Eq. (44),

$$(49a) \quad \frac{S_{\Sigma}}{N_{\Sigma}} = \frac{[\sqrt{S_{iw}}(1+1+1+\sqrt{0.8})]^2}{N_{iw}(1+1.01+1.02+1.03)} = 3.74 \left(\frac{S_{iw}}{N_{iw}} \right) ;$$

or, in decibels, the enhancement factor is

$$E. F. \text{ db} = 10 \log_{10} 3.74 = 5.73 \text{ db.}$$

CASE 2: Assume the same conditions as for Case 1, with the exception of the higher noise-temperature value for the East channel. The sum signal-to-noise ratio then becomes

$$(49b) \quad \frac{S_{\Sigma}}{N_{\Sigma}} = \frac{[\sqrt{S_{iw}}(1+1+1+\sqrt{0.8})]^2}{N_{iw}(1.0+1.01+1.48+1.03)} = 3.36 \left(\frac{S_{iw}}{N_{iw}} \right) .$$

The enhancement factor is reduced by the noisy channel to a value of

$$E. F. = 10 \log_{10} 3.36 = 5.27 \text{ db.}$$

CASE 3: Assume the same conditions as for Case 1, except the voltage gains of each channel will be optimized according to values determined in Appendix B. That is, the gain of the kth channel will be adjusted according to

$$A_{V_k} = \left(\frac{\sqrt{S_{ik}}}{\sqrt{S_{iw}}} \right) \left(\frac{N_{iw}}{N_{ik}} \right) .$$

Using the values of gain calculated by the above criteria (shown tabulated in Table III) the sum-channel signal-to-noise ratio is

$$(49c) \quad \frac{S_{\Sigma}}{N_{\Sigma}} = \frac{[\sqrt{S_{iw}}(1 + 0.99 + 0.98 + (0.87)(\sqrt{0.8}))]^2}{N_{iw}[1 + (0.99)^2(1.01) + (0.98)^2(1.02) + (0.87)^2(1.03)]}$$

$$= 3.76 \left(\frac{S_{iw}}{N_{iw}} \right) .$$

In decibels, the enhancement factor is

$$E. F. = 10 \log_{10}(3.76) = 5.75 \text{ db.}$$

CASE 4: The same conditions as for Case 2, except that the voltage gains are optimized as was done in Case 3. Thus

$$(49d) \quad \frac{S_{\Sigma}}{N_{\Sigma}} = \frac{[\sqrt{S_{iw}}(1 + 0.99 + (0.68) + (0.87)(\sqrt{0.8}))]^2}{N_{iw}[1 + (0.99)^2(1.01) + (0.68)^2(1.48) + (0.87)^2(1.03)]}$$

$$= 3.45 \left(\frac{S_{iw}}{N_{iw}} \right) .$$

The enhancement factor, in decibels, is

$$E. F. = 10 \log_{10} 3.45 = 5.38 \text{ db.}$$

From the above results it is seen that as long as the channels are approximately equal, the enhancement factor can approach the theoretical maximum quite closely. By optimizing the gains a small improvement was obtained, but this optimizing technique does not really pay dividends until the channels depart substantially from their proper values. The increased noise temperature in one channel was noticeable, but not as much as might have been anticipated.

CHAPTER VI
EFFECTS OF SYSTEM PARAMETER VARIATIONS

With the above results in mind, a detailed analysis will be made of the effects of parameter variations in the individual channels on the sum signal-to-noise ratio.

1. Phase Jitter

Since optimum combining occurs when all signals are in-phase, it is of interest to see how much phase jitter can be tolerated before the sum channel signal-to-noise ratio is degraded appreciably.

Phase jitter can be caused by noise voltages in the phase-lock loop, power-line fluctuations, thermal transients, and other such perturbations. By considering the phase terms, or the θ_k 's, as identically and symmetrically distributed random variables, Brenner and Tourdot⁴ have shown that signal degradation resulting from phase jitter can be expressed as

$$(50) \quad (\text{degradation in db}) = 10 \log \left[\frac{\sigma^2}{N} \left(1 - \frac{1}{4} \sigma^2 \right) + \left(1 - \frac{1}{2} \sigma^2 \right) \right]^2,$$

where

N = number of elements in array,

σ^2 = variance of phase jitter in each channel.

Equation (50) is shown plotted in Fig. 10.

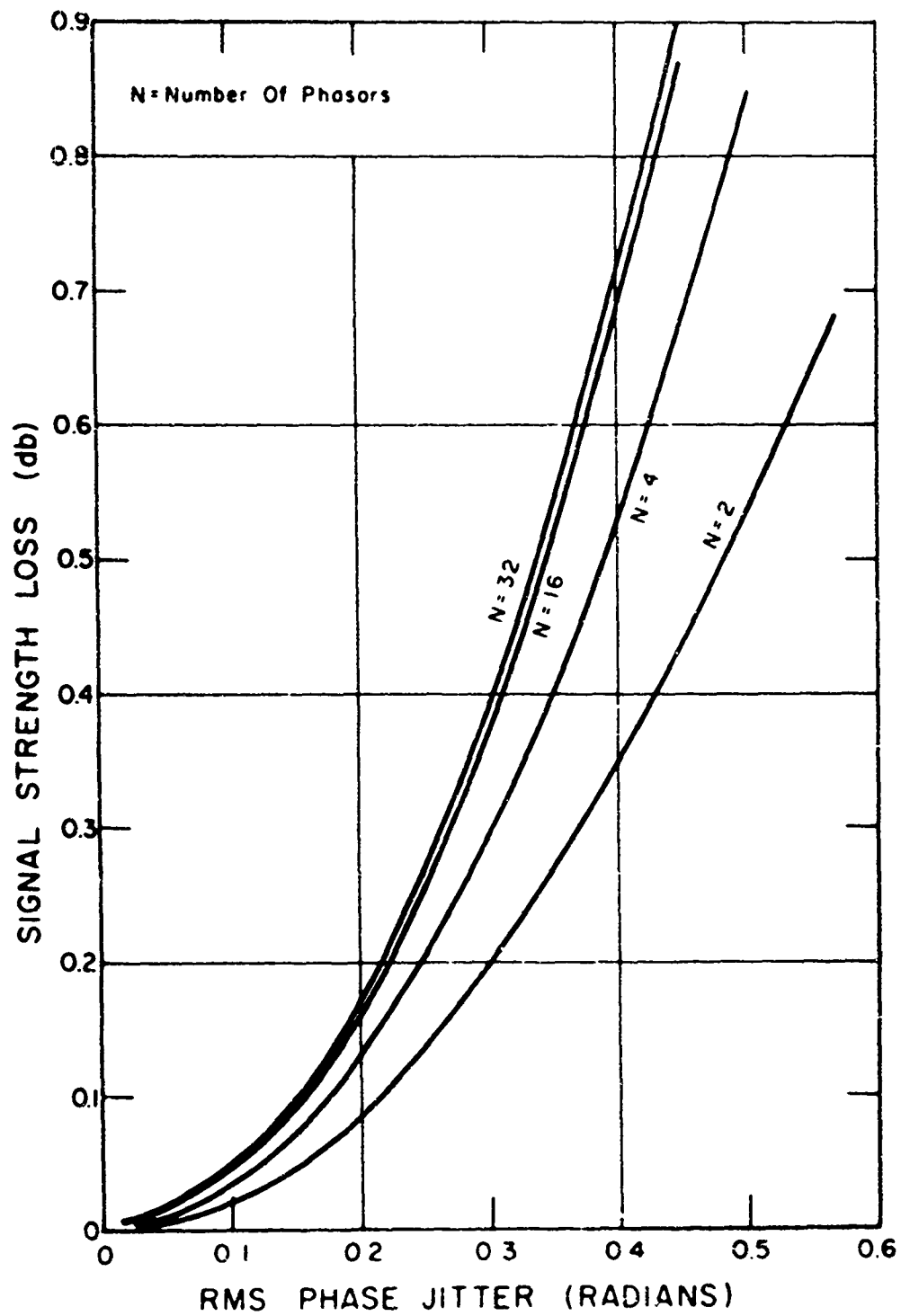

Fig. 10. Signal degradation vs. phase jitter.
 Reprinted from Brenner and Tourdot,
 Reference 4.

Considering the fact that for a loop to remain locked the phase variations must be kept considerably below $\frac{\pi}{4}$ radians, it is seen that the sum channel is relatively insensitive to phase jitter in the loops. In fact, if the loop design is such that the overall phase jitter does not degrade angle modulation that may be on the signals, then the summing will always be performed under near-optimum phase conditions.

2. Signal-Amplitude Variations

As mentioned above, optimum combining occurs when each channel is receiving equal signal power at its input. This indicates that excessive cable attenuation or decreased aperture efficiency in a channel can degrade overall performance. Ideally, such losses can be minimized and each antenna designed for best gain-to-noise-temperature ratio. However, an effect that cannot be eliminated is aperture blockage of one antenna by another at low elevation angles and certain azimuth angles. Such blockage is a function of antenna size, location, and spacing and has the effect of reducing the input signal power to the respective channel. In order to determine the amount of degradation of signal-noise ratio, an expression was developed to calculate the amount of blocking of one antenna by another on an optical ray-path basis. That is, the aperture plane, or disk, of each antenna was projected onto a reference plane

perpendicular to the sighting-line to the target. The amount of overlap, or mutual area, of these projected disks gave the amount of aperture blockage. Of course, since reflections and diffraction at each antenna will be inevitable, it is impossible to completely block out the signal. Also, to simplify calculations, uniformly illuminated apertures were assumed. Thus, the signal power was assumed to be decreased in direct proportion to the amount of shaded area. Since the edges of the antennas are actually illuminated at much lower levels than the center, these calculations give values that are considerably more pessimistic than occur in actual practice.

The results of these calculations show that no blocking occurs above an elevation angle of 30° regardless of azimuth angle. Between elevation angles of 10° and 30° the blocked area varies from less than one per cent to a maximum of only 28 per cent of the total available aperture area.

Since most operations are over elevation angles of about 5° to zenith, and since diffraction and tapered aperture illumination make the problem less severe, aperture blockage would typically have less than one db effect on the sum channel signal-to-noise ratio. Figure 11 shows the percentage of total aperture area available as a function of time for two typical Echo II satellite

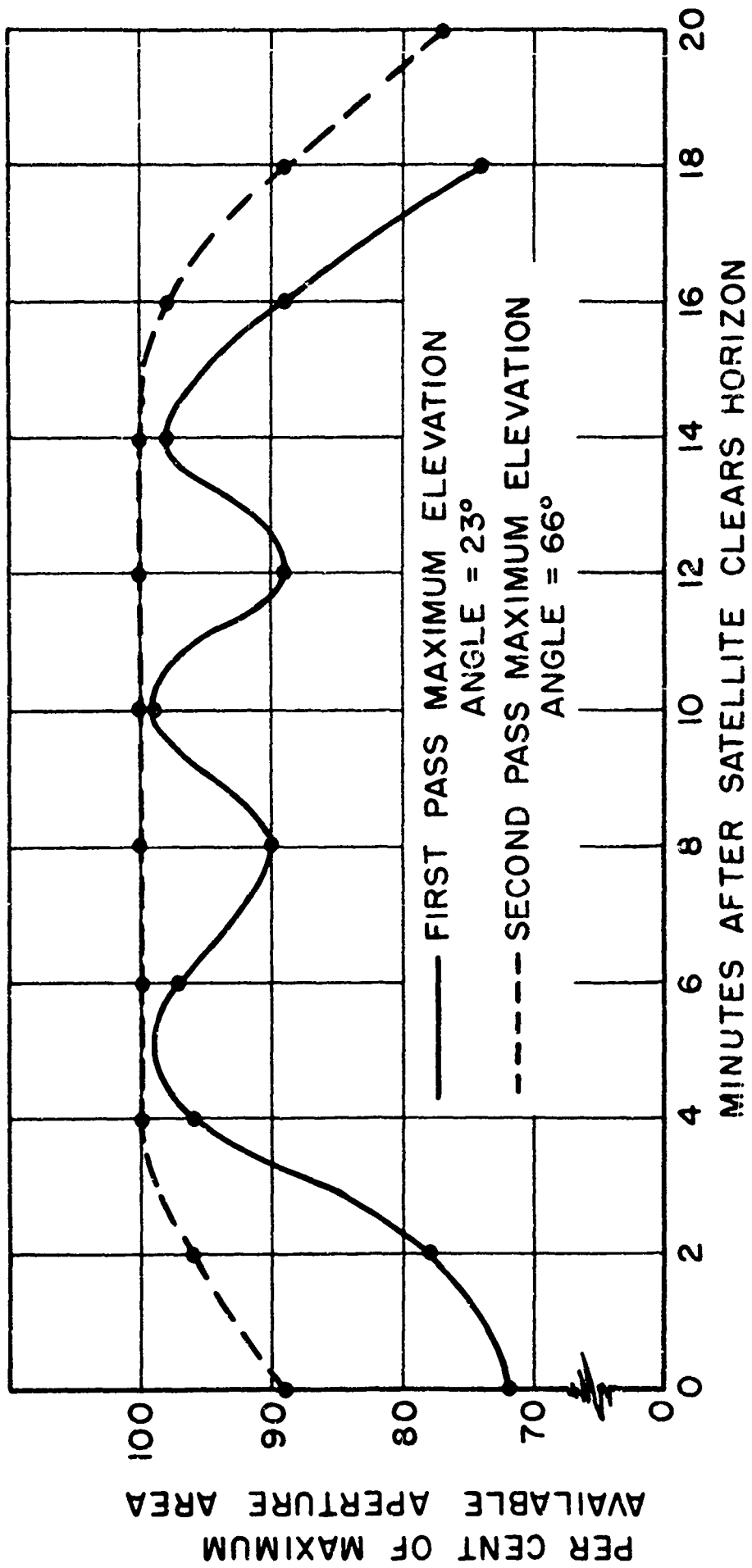

Fig. 11. Calculated value of available aperture area in percent of total during two successive passes of Echo II Satellite on April 24, 1965.

passes. The values were calculated using computed look-angle data for the satellite. It is seen that soon after acquisition more than 90 per cent of the total aperture is in use.

3. Excessive Noise Power

Another facet of Eq. (44) which must be given consideration is the effect of a channel with excessive noise power. This could result, for instance, from an increase in noise figure of one channel's receiver because of a malfunction of some type. It could also result from an increase in bandwidth caused by receiver detuning. At any rate, assume that all channels except one are at their proper operating values of system noise temperature and bandwidth. Then let

$$K_n = \frac{\text{noise power from defective channel}}{\text{noise power from reference channel}} \quad K_n \geq 1.$$

Then assuming other parameters are constant, the normalized signal-to-noise ratio from the sum channel is

$$(51) \quad \frac{1}{N} \left(\frac{S_\Sigma}{N_\Sigma} \right) = \frac{[NA_V S_i]^2}{\frac{1}{N} [A_V^2 K B (T_a + T_r) (N-1 + K_n)]} = \frac{N}{(N-1 + K_n)} \left(\frac{S_i}{N_i} \right),$$

where $\left(\frac{S_i}{N_i} \right)$ is the signal-noise ratio from the good channels.

Equation (51) is shown plotted in Fig. 12. Note that in each case the values of $\frac{S_\Sigma}{N_\Sigma}$ are normalized by $\frac{1}{N}$ so that the maximum possible value obtainable from the N channels is unity.

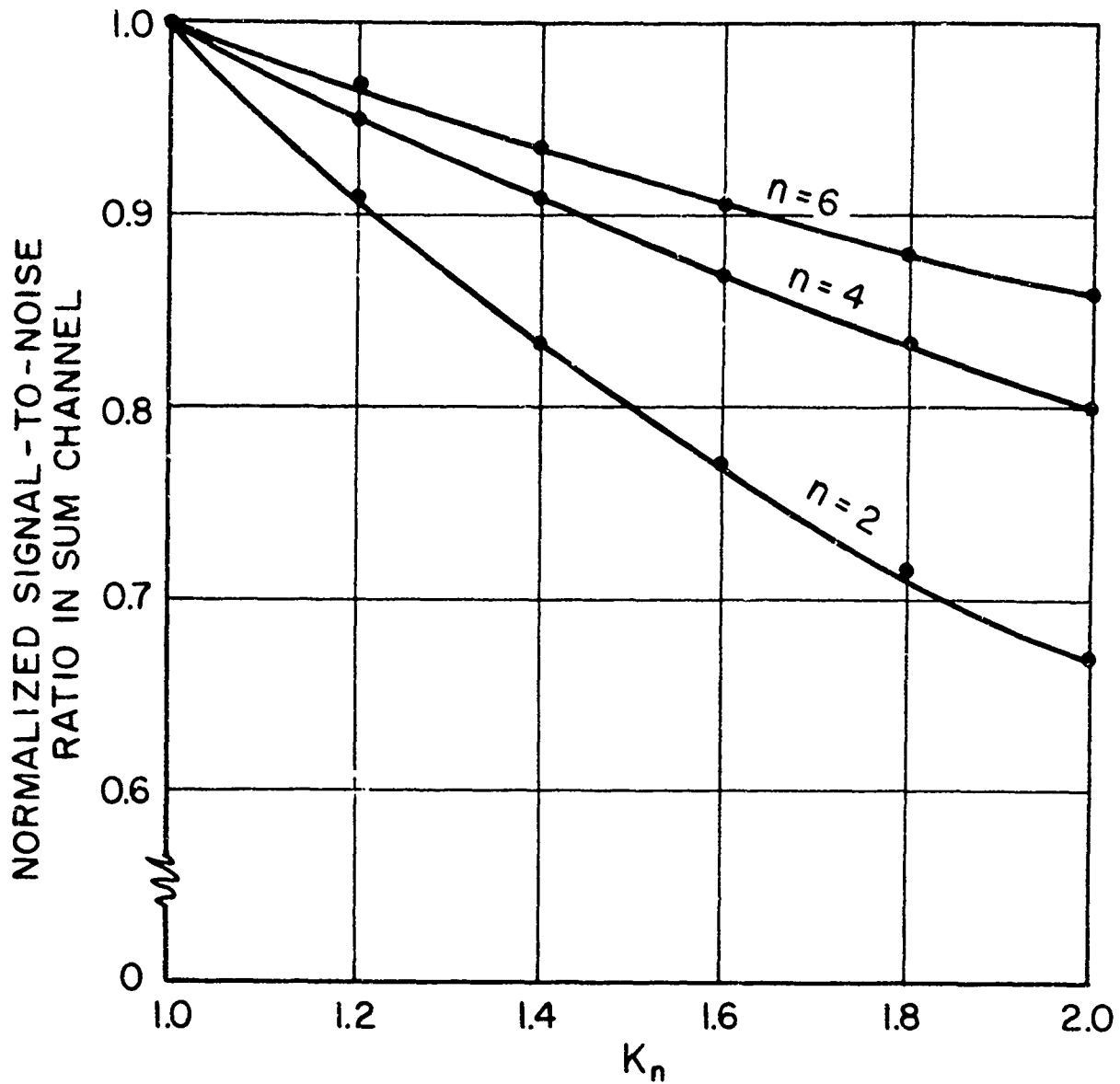

$$K_n = \frac{\text{noise power from defective channel}}{\text{noise power from reference channel}}$$

Fig. 12. Decrease of sum signal-to-noise ratio resulting from an increase in noise power from one channel.

4. Unequal Voltage Gains

The only remaining system parameter to consider is the effect of variations of the voltage gain of each channel. From Eq. (44), if all respective parameters of each channel are equal except for voltage gain, the normalized output signal-to-noise ratio is

$$(52) \quad \frac{1}{N} \left(\frac{S_{\Sigma}}{N_{\Sigma}} \right) = \frac{S_i \left[\sum_{k=1}^N A_{V_k} \right]^2}{N \left[N_i \sum_{k=1}^N A_{V_k}^2 \right]} .$$

Now assume that the gains of all channels are equal except one, which will vary over some range. Let

$$K_V = \frac{\text{gain of defective channel}}{\text{gain of reference channel}}, \quad K_V \geq 1 .$$

The normalized signal-to-noise ratio can now be expressed as

$$(53) \quad \left(\frac{S_{\Sigma}}{N_{\Sigma}} \right)_{\text{NORM}} = \left(\frac{S_i}{N_i} \right) \frac{[(N-1) + K_V]^2}{N[(N-1) + K_V^2]} .$$

Equation (53) is shown plotted in Fig. 13. This approach to an analysis of gain variations shows the effect of one channel changing considerably from all other channels, which could happen because of mistuning or a malfunction. A more descriptive analysis from an operational point of view would be to consider the gain of each channel

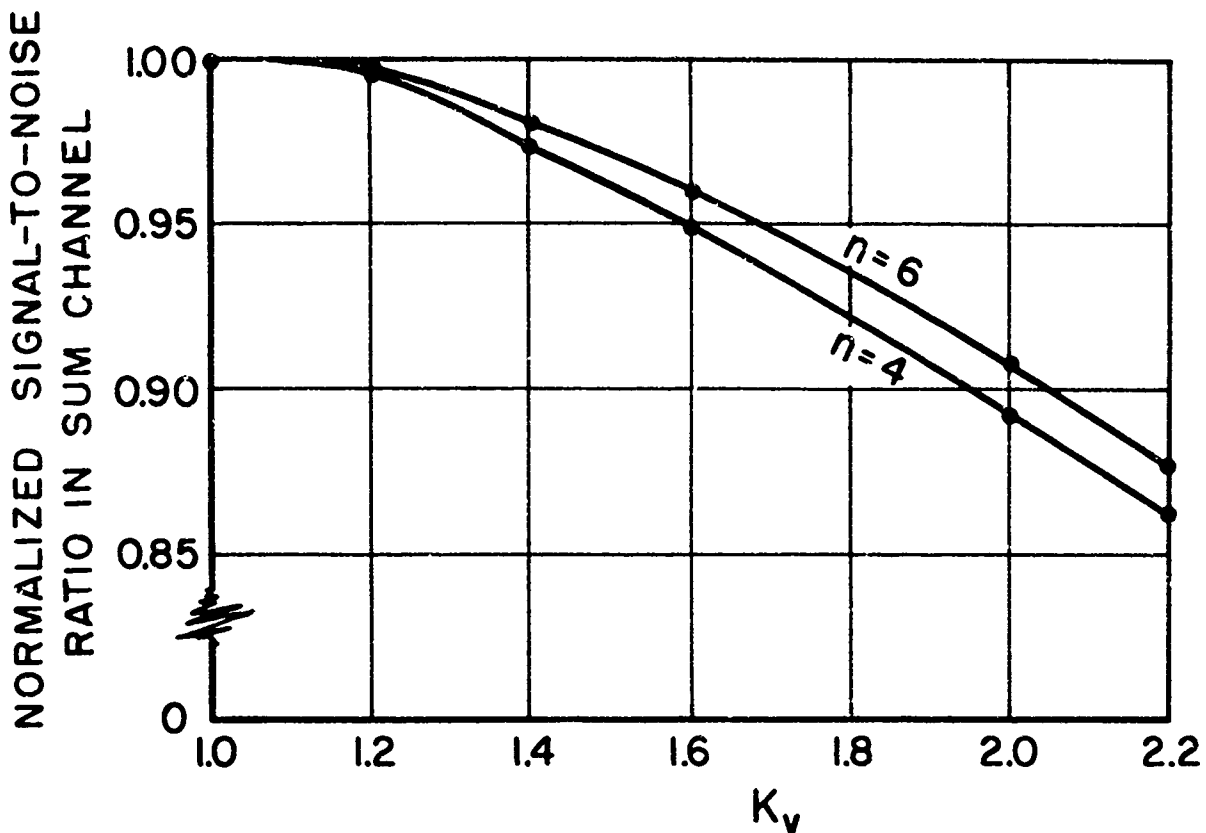

Fig. 13. $K_v = \frac{\text{gain of defective channel}}{\text{gain of reference channel}}$.

as a randomly varying quantity with time, and to calculate the average signal-to-noise ratio as a function of the spread, or variance, of each channel. However, such an analysis is almost hopelessly complicated, and beyond the scope of this paper. It is obvious, from Fig. 13, that the sum signal-to-noise ratio is reasonably insensitive to gain variations of 3 db or less as long as there are several channels.

5. Effect of Partially Correlated Noise

It has been assumed thus far that all noise voltages in the various channels are completely uncorrelated. However, it must be assumed in general that some percentage of the noise powers will be correlated. This is because a portion of the antenna noise in each channel will arrive from very distant sources (e. g., radio stars) and will produce very nearly the same noise voltages at each antenna feed. These voltages would be treated the same as signals by the summing circuit and would result in a decrease of the enhancement factor.

To get a quantitative measure of the effects of correlation in the noise signals, assume that the noise power input to each channel of the sum circuit can be expressed as the sum of the correlated power and uncorrelated power. That is,

$$(54) \quad N_k = \frac{A_{vk}^2 K T_{ck} B_k R_{ik}}{R_\Sigma} + \frac{A_{vk}^2 K T_{uk} B_k R_{ik}}{R_\Sigma}$$

where

N_k = total noise power input to sum circuit
of the kth channel,

T_{uk} = equivalent noise temperature of uncorrelated portion
of noise in kth channel, and

T_{ck} = equivalent noise temperature of correlated
portion of noise in kth channel.

Also,

$$(55) \quad T_{ck} + T_{uk} = T_{sk},$$

where T_{sk} = total system temperature of kth channel. To keep the analysis on a reasonably simple basis, it will be assumed that for the power represented by T_{ck} , the correlation between channels is complete. That portion of the noise powers will then add on a coherent basis and the uncorrelated portions will add in the usual incoherent fashion. Also, to keep the emphasis on the effects of correlation, the usual assumption of identical channels will be made. The output noise power from the sum channel can now be expressed as

$$(56) \quad N_{\Sigma} = \frac{A_V^2 K B R_i}{R_{\Sigma}} \left[\left| \sum_{k=1}^n \sqrt{T_{uk}} \right|^2 + \sum_{k=1}^n T_{ck} \right].$$

From Eqs. (48b) and (56), it can be seen that the enhancement factor is degraded by an amount proportional to the ratio of the uncorrelated noise power to the noise power with correlation. That is,

$$(57) \quad \begin{array}{l} \text{E. F. (with correlation)} \\ = (\text{E. F. without correlation}) \end{array} \left[\frac{\sum_{k=1}^N T_{sk}}{\left(\sum_{k=1}^N \sqrt{T_{ck}} \right)^2 + \sum_{k=1}^N T_{uk}} \right].$$

For an array of four identical elements, this becomes

$$(58a) \quad E. F. = 4 \left[\frac{4T_s}{16T_c + 4T_u} \right]$$

$$(58b) \quad = \frac{4}{3\left(\frac{T_c}{T_s}\right) + 1}, \quad 0 \leq \left(\frac{T_c}{T_s}\right) \leq 1.$$

Equation (58b) is shown plotted in Fig. 14 as a function of the ratio of the amount of correlated noise power to total noise power in the channel. It is seen that for the array to approach maximum possible performance the correlated power must represent only a small fraction of the total system noise power.

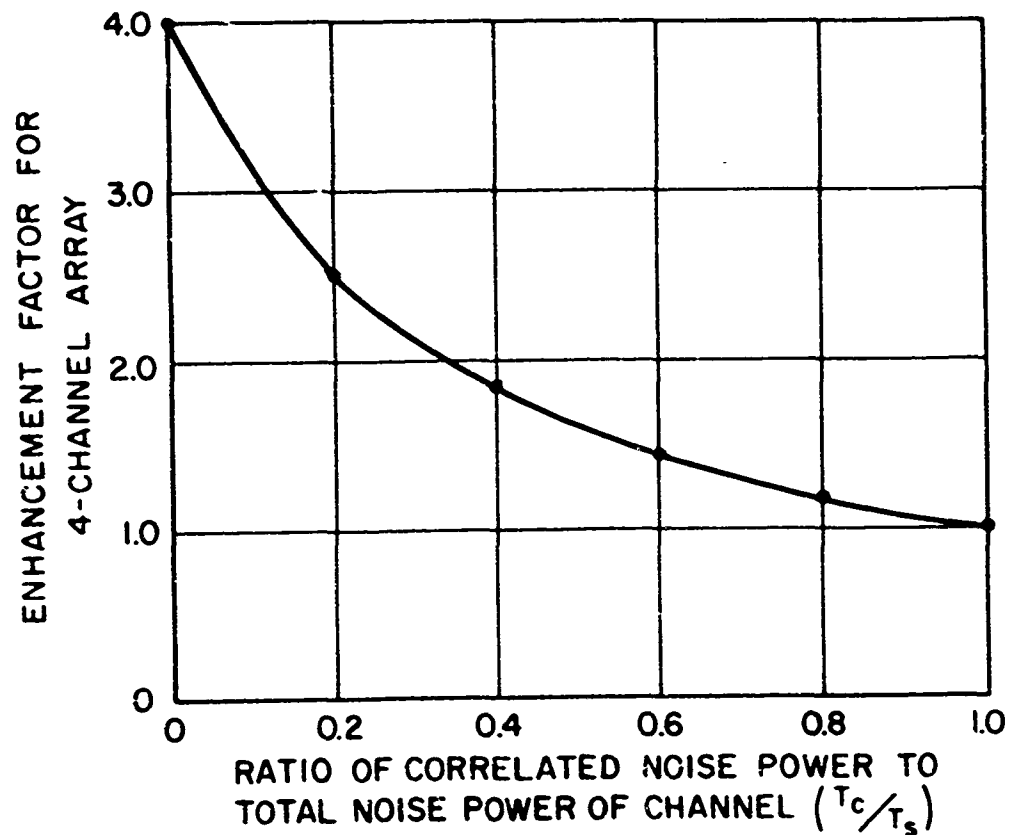

Fig. 14. Effect of correlated noise on enhancement factor.

CHAPTER VII
 TABULATED VALUES OF GAIN-TO-NOISE
 TEMPERATURE RATIOS

The importance of the gain-to-noise temperature ratio of the individual elements, as well as for the array, has already been stressed. Table IV shows the values of the ratios for each element based on the measured values already presented. Also shown is the calculated value for the total array, along with calculated values of the enhancement factor.

TABLE IV
 Tabulated Values of Gain-to-Noise
 Temperature Ratios

Element	Antenna G/NT deg ⁻¹	Channel G/NT deg ⁻¹	Array G/NT deg ⁻¹	Calculated Enhancement Factor
North	431	57.5	-	-
East	498	45.0	-	-
South	187	44.8	-	-
West	415	58.0	-	-
*Array				
Case 1		+58.0	217	3.74 (5.73 db)
Case 2		+58.0	195	3.36 (5.26 db)
Case 3		+58.0	218	3.76 (5.76 db)
Case 4		+58.0	200	3.45 (5.38 db)

*See Section V-4

†Reference antenna used in calculations (see Section V-4).

CHAPTER VIII SUMMARY

This report presents the results of measurements made of the antenna gain, antenna noise temperature, and receiver noise temperature of the four receiving systems at The Ohio State University Satellite Communication Center. An analysis is made of the effect these three parameters have on system sensitivity and of the importance of accurate knowledge of each.

The antenna gains were measured to be 43.0 ± 0.5 db for the slave-antennas and 42.0 ± 0.5 db for the tracking, or master, antenna. This results in effective aperture efficiencies of 43 per cent and 34 per cent, respectively. The gain differential results from losses in the master feed-structure.

The antenna temperatures, including effects of interconnecting cable losses, averaged 104° , and approximately 50° without the cables, measured at zenith elevation angle.

The receiver noise figures averaged approximately 3 db, which was slightly higher than the design-goal value of 2.7 db.

These values yield a system sensitivity, using an 18 kc bandwidth receiver, of -130 dbm.

The gain-to-noise temperature ratio is a convenient figure-of-merit for the total array and can be expressed as an enhancement

factor which operates on the gain-to-noise temperature ratio of one of the array elements. This enhancement factor is a function of the system parameters of the individual elements.

For the four-element array at The Ohio State University Antenna Laboratory, calculated values of the array gain-to-noise temperature ratio varied from 5.26 to 5.76 db above the gain-to-noise temperature ratio of the reference element.

The array gain-to-noise temperature is relatively insensitive to small variations in the system parameters of the individual elements, such as voltage gain fluctuations and phase jitter.

REFERENCES

1. Annual Summary Report, (1072-7), 30 November 1963, Antenna Laboratory, The Ohio State University Research Foundation; prepared under Contract AF 30(602) -2166, Rome Air Development Center, Griffiss Air Force Base, New York. (RADC-TDR-64-72) (AD 600 651)
2. Eberle, J. W., "An Adaptively Phased, Four-Element Array of Thirty-foot Parabolic Reflectors for Passive Communication Systems," IEEE Transactions on Antennas and Propagation, Volume AP-12, Number 2, March, 1964.
3. Kraus, J. D., Antennas, McGraw-Hill Book Company, 1950, p. 456.
4. Brenner, C. H. and Tourdot, J. E., "Active Array Technique," (1963-2), 15 April 1965, Antenna Laboratory, The Ohio State University Research Foundation; prepared under Contract AF 30(602) -3601, Rome Air Development Center, Griffiss Air Force Base, New York. (RADC-TDR-65-232, Vol. I)

APPENDIX A ARRAY NOISE TEMPERATURE

It was pointed out in the previous sections that the total noise temperature of a receiving system determines its ultimate sensitivity. It is a quantity that can be measured by straightforward methods, and tells the systems engineer how much signal power must be made available to the receiver input to achieve a given output signal-to-noise ratio. It has been shown that the array gain-to-noise temperature ratio describes the performance of the array. However, it would be of interest to try to define a noise temperature of the array.

However, the definition and use of such a quantity must be approached with caution. To be meaningful, the definition must be such that the term can be measured, or at least calculated from measurable quantities. For instance, in a conventional single-channel system the noise temperature is independent of the receiver gain. Since noise power and signal power are affected equally by a change of gain, the output signal-to-noise ratio remains constant. Consider, however, the output noise power from the sum channel, as expressed in Eq. (44), i. e.,

$$\begin{aligned}
(59) \quad N_{\Sigma} &= \sum_{k=1}^N A_{vk}^2 B_k (T_{ak} + T_{rk}) \\
&= K A_{v1}^2 B_1 (T_{a1} + T_{R1}) + K A_{v2}^2 B_2 (T_{a2} + T_{R2}) + \dots \\
&\quad + K A_{vN}^2 B_N (T_{aN} + T_{RN}).
\end{aligned}$$

Obviously, this expression is not, in general, independent of the receiver gain of each channel, nor is it easily normalized.

The expression, though complex, can be simplified by making certain assumptions. First of all, it is not unreasonable to assume that the bandwidth and noise temperature of each channel is a constant over considerable lengths of time. Any receiver of commercial quality would be designed well enough that the bandwidth would not be affected by normal operating conditions. It can also be assumed that, short of a malfunction, the receiver noise figure would be unaffected by small variations from normal conditions. Of course, if the antenna temperature is a significant fraction of the receiver temperature, variations in elevation angle could change the total system temperature, but this will be considered a special case. It will thus be assumed that the bandwidth and noise temperature of each channel are constant and known quantities. The only remaining variable in Eq. (44), and the only one which is likely to vary over a short period of time, is the gain of each receiver. It is also the

quantity which is the most difficult to measure, since it includes the gain of RF amplifiers, conversion gain of RF mixers, loss of any interconnecting cable, and the gain of the IF amplifiers.

Since each channel of the array would most likely be designed to be identical to all other channels, the output noise power expression reduces to

$$(60) \quad N_{\Sigma} = K T_S B A_{V1}^2 \left[1 + \left(\frac{A_{V2}}{A_{V1}} \right)^2 + \dots + \left(\frac{A_{VN}}{A_{V1}} \right)^2 \right],$$

where T_S = system temperature of the individual channels. If the gain of each channel could be adjusted to be equal then

$$(61) \quad N_{\Sigma} = N K T_S B A_V^2.$$

Referring this to the "input terminals" of the sum channel, the equivalent input noise power for the sum channel is

$$(62) \quad N_{i\Sigma} = \frac{N_{\Sigma}}{A_V^2} = K N T_S B,$$

and the noise temperature of the array simplifies to

$$(63) \quad T_{\Sigma} = N T_S.$$

Using this approach, the noise temperature of the four-element array at the Antenna Laboratory, assuming a system noise-temperature of 396°K in each channel, would be 1584°K. It is at this point, however, that caution must be exercised. A natural impulse on the part

of the system engineer would be to start calculating signal-to-noise ratios based on a noise temperature of NT_S and an antenna aperture area of N times an individual element. But this results in no improvement of signal-to-noise ratio, which contradicts the results of Eq. (44). The reason for this apparent contradiction is the way in which the signals are combined in the summing circuit. Since the signals add on an instantaneous voltage basis, the output signal is N times the input, or making the output signal power N^2 times the input from any channel. Therefore, if a noise temperature of NT_S is used for calculations, an effective aperture area of N^2 times the area of one element must be used for signal power calculations. An expression could be developed in which the effective aperture area is just N times greater than one element, but then the value of system noise temperature would also change.

If the noise temperatures and bandwidths are not equal, the sum channel noise power output can be expressed as

$$(64) \quad N_{\Sigma} = A_{v1}^2 N_1 \left[1 + \left(\frac{A_{v2}}{A_{v1}} \right)^2 \frac{N_2}{N_1} + \left(\frac{A_{v3}}{A_{v1}} \right)^2 \frac{N_3}{N_1} + \dots + \left(\frac{A_{vN}}{A_{v1}} \right)^2 \frac{N_N}{N_1} \right],$$

where

$$\begin{aligned} N_k &= \text{noise power of } k\text{th channel referred to its input terminals} \\ &= K(T_{ak} + T_{rk}) B_k. \end{aligned}$$

Normalizing this to the gain of the reference (number one) channel,

$$(65) \quad \frac{N_{\Sigma}}{A_{V1}^2} = K T_{S1} B_1 \left[1 + \left(\frac{A_{V2}}{A_{V1}} \right)^2 \left(\frac{T_{S2} B_2}{T_{S1} B_1} \right) + \left(\frac{A_{V3}}{A_{V1}} \right)^2 \left(\frac{T_{S3} B_3}{T_{S1} B_1} \right) + \dots + \left(\frac{A_{VN}}{A_{V1}} \right)^2 \left(\frac{T_{SN} B_N}{T_{S1} B_1} \right) \right].$$

The sum channel system temperature is , then,

$$(66) \quad T_{\Sigma} = T_{S1} [1 + G_2^2 \alpha_2 + G_3^2 \alpha_3 + \dots + G_N^2 \alpha_N] ,$$

where

α_k = ratio of noise power of kth channel referred to its input to the noise power of reference channel referred to its input; and

G_k = the voltage gain ratio of the kth channel to the reference channel.

It is apparent from this expression that, in general, the sum channel noise temperature is not a fixed quantity that can be used without reservation in system-type calculations. For a given expression for such a system temperature, an associated expression for effective aperture area must also be used if the true signal-to-noise ratios are to be obtained. As a further demonstration of this, consider the system noise temperature expression when the gains are weighted for optimum signal-to-noise ratio. In Case 2 of

Appendix B, it is shown that, for equal signals but unequal noise powers, the best output signal-to-noise ratio from the sum channel results when the voltage gains are weighted inversely to the noise power of each channel. To do this, one would first measure the noise bandwidth and system temperature of each channel by conventional means. The channel which had the smallest bandwidth-noise-temperature product would be used as a reference. These measurements would give the value of the α_k 's of eq. (66), as well as the best values for the G_k 's. That is, using the measured values of noise temperature and bandwidth of each channel

$$(67) \quad \alpha_k = \frac{K(T_{ak} + T_{rk}) B_k}{K(T_{a1} + T_{r1}) B_1}, \quad \alpha_k \geq 1,$$

and the voltage gains of the various channels would be set according to

$$(68) \quad G_k = \left(\frac{A_{vk}}{A_{v1}} \right) = \frac{1}{\alpha_k} G_k \leq 1.$$

Using these optimized values of gain, the array noise temperature becomes

$$(69) \quad T_{\Sigma} = T_{S1} \left[1 + \left(\frac{1}{\alpha_2} \right)^2 (\alpha_2) + \left(\frac{1}{\alpha_3} \right)^2 (\alpha_3) + \dots + \left(\frac{1}{\alpha_N} \right)^2 (\alpha_N) \right]$$

$$\begin{aligned}
 (69) \quad & = TS_1 \left[1 + \frac{1}{\alpha_2} + \frac{1}{\alpha_3} + \dots + \frac{1}{\alpha_N} \right] \\
 (\text{cont}) \quad & = TS_1 \sum_{k=1}^N \frac{1}{\alpha_k} .
 \end{aligned}$$

This expression, though, can be even more misleading than Eq. (63). Since the value of each α is greater than unity, the value of system temperature in this case will be equal to or less than NT_S . On the surface, this implies that as the gain of a bad channel is reduced the system sensitivity increases over that of which results when all channels are normal. Again, this contradiction results from the fact that the values of voltage gain have not also been incorporated into the expression for signal power. When this is done, the signal-to-noise ratio is seen to decrease from the optimum figure, as would be expected.

The crux of the matter is that although expressions can be developed for the noise-temperature of the array, these expressions are subject to qualification and must be used with care. The only completely general criterion for evaluating the operation of the array is the sum-channel signal-to-noise ratio, or the array gain-to-noise temperature ratio.

APPENDIX B
OPTIMUM COMBINING FOR DOMINANT SIGNAL OR NOISE

The sum-channel signal-to-noise voltage ratio can be expressed as

$$(70) \quad S/N = \frac{\sum_{i=1}^M (G_i S_i)}{\left[\sum_{i=1}^M (G_i N_i)^2 \right]^{\frac{1}{2}}},$$

where

$$i = 1, 2, 3, \dots, M;$$

S_i = signal voltages which add coherently;

N_i = noise voltages which add on power basis;

G_i = voltage of the i th channel;

$N_1 < N_p$ where $p = 2, \dots, M$, $\rightarrow G_1 = 1$; and

$\max (S/N)^2$ is equivalent to $\max (S/N)$.

The power ratio is given by

$$(71) \quad (S/N)^2 = \frac{\left[\sum_{i=1}^M (G_i S_i) \right] \left[\sum_{j=1}^M (G_j S_j) \right]}{\left[\sum_{i=1}^M (G_i N_i)^2 \right]}.$$

To find the maximum value of this expression, take the derivative with respect to an arbitrary reference channel; i. e.,

$$(72) \quad \frac{d\left(\frac{S}{N}\right)^2}{dG_k} = \frac{\left\{ \left[\sum_{i=1}^M (G_i N_i)^2 \right] \left\{ \left[\sum_{i=1}^M (G_i S_i) \right] S_k + \left[\sum_{j=1}^M (G_j S_j) \right] S_k \right\} - \left\{ \left[\sum_{i=1}^M (G_i S_i) \right] \left[\sum_{j=1}^M (G_j S_j) \right] \right\} (2N_k^2 G_k) \right\}}{\left[\sum_{i=1}^M (G_i N_i)^2 \right]}$$

Now setting this derivative equal to zero,

$$\frac{d\left(\frac{S}{N}\right)^2}{dG_k} = 0$$

or

$$(73) \quad \left[\sum_{i=1}^M (G_i N_i)^2 \right] \left[S_k \sum_{i=1}^M \right] = G_k N_k^2 \left[\sum_{i=1}^M \right] \left[\sum_{i=1}^M (G_i S_i) \right].$$

By canceling terms, this reduces to

$$(74) \quad S_k \left[\sum_{i=1}^M (G_i N_i)^2 \right] = G_k N_k^2 \left[\sum_{j=1}^M G_j S_j \right].$$

This expression is the required gain for the kth channel for optimum signal-to-noise ratio. Consider the following cases:

CASE 1:

- (1) All N_i are equal $N_i = N$ and
- (2) All S_i are, in general, unequal.

$$(75) \quad S_k \left[\sum_{i=1}^M (G_i)^2 \right] = G_k \left[\sum_{j=1}^M G_j S_j \right];$$

$$(76) \quad \frac{S_k}{G_k} = \left[\sum_{j=1}^M G_j S_j \right] / \left[\sum_{i=1}^M (G_i)^2 \right] = \text{const}; \text{ and}$$

$$S_1/G_1 = S_1 = S_2/G_2 = \dots = S_k/G_k = \dots = S_N/G_N;$$

$$(77) \quad G_k = (S_k/S_1), \quad k = 2, 3, \dots, N.$$

This is the familiar result for diversely combining signals of unequal amplitudes.

CASE 2:

Now assume that the signals are equal, but the channel noise powers are unequal. Thus,

- (1) All N_i are in general unequal and
- (2) All S_i are equal; $S_i = S$.

$$(78) \left[\sum_{i=1}^M (G_i N_i)^2 \right] = G_k N_k^2 \left[\sum_{i=1}^M G_i \right],$$

$$(79) G_k N_k^2 = \left[\sum_{i=1}^M (G_i N_i)^2 \right] / \left[\sum_{i=1}^M G_i \right],$$

$$(80) G_1 N_1^2 = N_1^2 = G_2 N_2^2 = \dots = G_k N_k^2 = \dots = G_M N_M^2 \text{ and}$$

$$G_k = (N_1 / N_k)^2.$$

For optimum combining, the voltage gain of each channel must be inversely proportional to its own noise power.

CASE 3:

Finally, take the completely general case, That is, assume that

(1) All S_i are in general unequal and

(2) All N_i are in general unequal.

$$(81) S_k \left[\sum_{i=1}^M (G_i N_i)^2 \right] = G_k N_k^2 \left[\sum_{j=1}^M G_j S_j \right],$$

$$(82) S_k / G_k N_k^2 = \left[\sum_{j=1}^M G_j S_j \right] / \left[\sum_{i=1}^M (G_i N_i)^2 \right] = \text{const, and}$$

$$S_1 / G_1 N_1^2 = S_2 / G_2 N_2^2 = \dots = S_j / G_j N_j^2 = \dots = S_M / G_M N_M^2.$$

Let $S_k/N_k^2 \geq S_i/N_i^2$, where $i = 1, \dots, M \neq k$; for this case, let $G_k = 1$.

$$(83) \quad G_j = (S_j/N_j^2) / (S_k/N_k^2) \max_{j \neq k} \quad j = 1, 2, \dots, M$$

This is the generalized expression for the value of voltage gain for optimum combining.

REFERENCE

Kahn, IRE, November 1949, p. 1704 .

UNCLASSIFIED
Security Classification

DOCUMENT CONTROL DATA - R&D		
<small>(Security classification of title, body of abstract and indexing annotation must be entered when the overall report is classified)</small>		
1. ORIGINATING ACTIVITY (Corporate author) The Antenna Laboratory Ohio State University Research Foundation 1320 Kinnear Road, Columbus, Ohio 43212		2a. REPORT SECURITY CLASSIFICATION <u>Unclassified</u>
		2b. GROUP
3. REPORT TITLE HIGH GAIN ANTENNA TECHNIQUES System Gain-to-Noise Temperature Ratio Measurements on an Adaptively Phased Array		
4. DESCRIPTIVE NOTES (Type of report and inclusive dates) Interim		
5. AUTHOR(S) (Last name, first name, initial) Hayes, Delmer D.		
6. REPORT DATE March 1966	7a. TOTAL NO. OF PAGES 69	7b. NO. OF REFS 4
8a. CONTRACT OR GRANT NO. AF30(602)-3601	9a. ORIGINATOR'S REPORT NUMBER(S) 1963-1	
b. PROJECT NO. 4519	9b. OTHER REPORT NO(S) (Any other numbers that may be assigned this report) RADC-TR-66-125, Vol I of II Volumes	
c. Task No. 451901		
d.		
10. AVAILABILITY/LIMITATION NOTICES Distribution of this report is not limited.		
11. SUPPLEMENTARY NOTES	12. SPONSORING MILITARY ACTIVITY Rome Air Development Center (EMCRR) Griffiss AFB NY 13440	
13. ABSTRACT Factors affecting the ultimate sensitivity of a typical microwave receiving system are discussed. It is shown that the receiver noise-temperature and the antenna gain-to-noise-temperature ratio are the dominant parameters in determining system capabilities. Data is presented, along with the technique used to obtain the data, for the receiver noise temperature, the antenna gain, and the antenna noise temperature for each element of the array. An expression is developed for the gain-to-noise-temperature ratio of the array and is shown to be equivalent to an enhancement factor operating on the individual element gain-to-noise-temperature ratio. The effects of system parameter variations are studied and typical values of enhancement factor are calculated. It is concluded that for minor variations in parameters the enhancement factor is affected very little.		

DD FORM 1473
1 JAN 64

UNCLASSIFIED
Security Classification

14	KEY WORDS	LINK A		LINK B	
		ROLE	WT	ROLE	WT
Antennas Phased Array Noise Temperature Gain-to-Noise Temperature Ratio					

INSTRUCTIONS

1. **ORIGINATING ACTIVITY:** Enter the name and address of the contractor, subcontractor, grantee, Department of Defense activity or other organization (*corporate author*) issuing the report.
- 2a. **REPORT SECURITY CLASSIFICATION:** Enter the overall security classification of the report. Indicate whether "Restricted Data" is included. Marking is to be in accordance with appropriate security regulations.
- 2b. **GROUP:** Automatic downgrading is specified in DoD Directive 5200.10 and Armed Forces Industrial Manual. Enter the group number. Also, when applicable, show that optional markings have been used for Group 3 and Group 4 as authorized.
3. **REPORT TITLE:** Enter the complete report title in all capital letters. Titles in all cases should be unclassified. If a meaningful title cannot be selected without classification, show title classification in all capitals in parenthesis immediately following the title.
4. **DESCRIPTIVE NOTES:** If appropriate, enter the type of report, e.g., interim, progress, summary, annual, or final. Give the inclusive dates when a specific reporting period is covered.
5. **AUTHOR(S):** Enter the name(s) of author(s) as shown on or in the report. Enter last name, first name, middle initial. If military, show rank and branch of service. The name of the principal author is an absolute minimum requirement.
6. **REPORT DATE:** Enter the date of the report as day, month, year, or month, year. If more than one date appears on the report, use date of publication.
- 7a. **TOTAL NUMBER OF PAGES:** The total page count should follow normal pagination procedures, i.e., enter the number of pages containing information.
- 7b. **NUMBER OF REFERENCES:** Enter the total number of references cited in the report.
- 8a. **CONTRACT OR GRANT NUMBER:** If appropriate, enter the applicable number of the contract or grant under which the report was written.
- 8b, 8c, & 8d. **PROJECT NUMBER:** Enter the appropriate military department identification, such as project number, subproject number, system numbers, task number, etc.
- 9a. **ORIGINATOR'S REPORT NUMBER(S):** Enter the official report number by which the document will be identified and controlled by the originating activity. This number must be unique to this report.
- 9b. **OTHER REPORT NUMBER(S):** If the report has been assigned any other report numbers (*either by the originator or by the sponsor*), also enter this number(s).
10. **AVAILABILITY/LIMITATION NOTICES:** Enter any limitations on further dissemination of the report, other than those

imposed by security classification, using standard statements such as:

- (1) "Qualified requesters may obtain copies of this report from DDC."
- (2) "Foreign announcement and dissemination of this report by DDC is not authorized."
- (3) "U. S. Government agencies may obtain copies of this report directly from DDC. Other qualified DDC users shall request through _____."
- (4) "U. S. military agencies may obtain copies of this report directly from DDC. Other qualified users shall request through _____."
- (5) "All distribution of this report is controlled. Qualified DDC users shall request through _____."

If the report has been furnished to the Office of Technical Services, Department of Commerce, for sale to the public, indicate this fact and enter the price, if known.

11. **SUPPLEMENTARY NOTES:** Use for additional explanatory notes.
12. **SPONSORING MILITARY ACTIVITY:** Enter the name of the departmental project office or laboratory sponsoring (*paying for*) the research and development. Include address.
13. **ABSTRACT:** Enter an abstract giving a brief and factual summary of the document indicative of the report, even though it may also appear elsewhere in the body of the technical report. If additional space is required, a continuation sheet shall be attached.

It is highly desirable that the abstract of classified reports be unclassified. Each paragraph of the abstract shall end with an indication of the military security classification of the information in the paragraph, represented as (TS) (S) (C) or (U).

There is no limitation on the length of the abstract. However, the suggested length is from 150 to 225 words.

14. **KEY WORDS:** Key words are technically meaningful terms or short phrases that characterize a report and may be used as index entries for cataloging the report. Key words must be selected so that no security classification is required. Identifiers, such as equipment model designation, trade name, military project code name, geographic location, may be used as key words but will be followed by an indication of technical context. The assignment of links, rules, and weights is optional.