

File 66-60911

AD630685

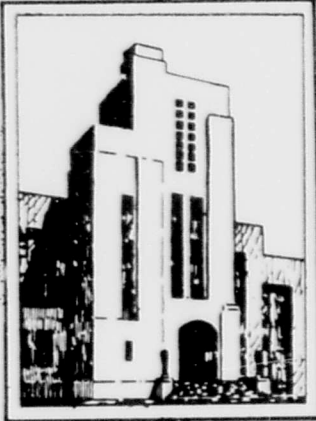

DEPARTMENT OF THE NAVY
DAVID TAYLOR MODEL BASIN

FOR FEDERAL SCIENTIFIC AND
TECHNICAL INFORMATION

Hardcopy | Microfilm

6-60 0.75 44 as

ARCHIVE COPY

Code 1

HYDROMECHANICS

ON CERTAIN PROBLEMS OF WATER JET PROPULSION

(Über Probleme des Wasserstrahltriebs)

○

AERODYNAMICS

by

DDC

APR 12 1966

○

Prof. S. Schuster, Dr.-Ing.
H. Schwanecke, Dr.-Ing.
R. Darnedde, Dipl.-Ing.
M. Schmiechen, Dipl.-Ing.
H. J. Schwechheimer, Dipl.-Ing.
Berlin

STRUCTURAL
MECHANICS

Lecture Series with Demonstrations Delivered at the
Versuchsanstalt für Wasserbau und Schiffbau
(Research Institute for Hydraulic Engineering
and Shipbuilding), Berlin Tank

○

Translated by E. N. Labouvie, Ph.D.

APPLIED
MATHEMATICS

Distribution of this document
is unlimited.

This translation may be distributed within the United States and its Territories. Any forwarding of the translation outside this area is done on the responsibility of the forwarder and is neither approved nor disapproved by the David Taylor Model Basin.

BLANK PAGE

ON CERTAIN PROBLEMS OF WATER JET PROPULSION
(Über Probleme des Wasserstrahlantriebs)

by

Prof. S. Schuster, Dr. Ing.
H. Schwanecke, Dr. Ing.
R. Darnedde, Dipl.-Ing.
M. Schmoechen, Dipl.-Ing.
H. J. Schwechheimer, Dipl.-Ing.
Berlin

**Lecture Series with Demonstrations Delivered at the
Versuchsanstalt für Wasserbau und Schiffbau
(Research Institute for Hydraulic Engineering
and Shipbuilding), Berlin Tank**

Jahrb. STG, Vol. 54, 1960, pp. 195-232.

Translated by E. N. Labouvie, Ph.D.

August 1962

Translation 306

**Distribution of this document
is unlimited.**

TABLE OF CONTENTS

	Page
ABSTRACT	1
1. INTRODUCTION (by S. Schuster)	2
1.1 Definition and Statement of the Problem	2
1.2 Outline of the Historical Development	3
1.3 Anticipated Lines of Development	7
2. SURVEY OF UNCONVENTIONAL JET-PROPULSION SYSTEMS AND SEVERAL PRELIMINARY INVESTIGATIONS (by R. Dervede)	9
2.1 Description of Propulsion Mechanisms	9
2.2 Several Preliminary Investigations	13
3. THEORETICAL FORMULATIONS (by M. Schmiechen)	20
3.1 Initial Assumptions	20
3.2 Dimensional Analysis	20
3.3 Asymptotic Thrust Law	23
3.4 Extended Thrust Law	26
3.5 Mathematical Model	29
3.6 Quasi-Steady Flows	30
3.7 A Direct Formula	34
3.8 Retrospection	35
4. IMPULSE TUBE WITH INTERMITTENT GAS-WATER OPERATION (by H. Schwechheimer).....	36
4.1 Fundamental Facts about the Method of Operation.....	36
4.2 Theoretical Considerations	38
5. CONTINUOUSLY OPERATING JET-PROPULSION SYSTEMS (by H. Schwanecke).....	41
5.1 General Remarks	41
5.2 Model Tests	45
5.3 Examples of Various Designs.....	47
6. SUMMARY	52
REFERENCES	52
DISCUSSION	55

LIST OF FIGURES

	Page
Figure 1 – Jet-Propulsion Mechanism of WATERWITCH, 1867	3
Figure 2 – Gill Jet-Propulsion Mechanism, 1925.....	4
Figure 3 – Nowka Jet-Propulsion Mechanism, 1926, Built inside the Hull.....	4
Figure 4 – Nowka Jet-Propulsion Mechanism, 1926.....	4
Figure 5 – Kermath Hydrojet Mechanism.....	6
Figure 6a – Dowty-Hamilton Jet-Propulsion System.....	6
Figure 6b – KSB-Nowka Jet-Propulsion System.....	6
Figure 7 – Intermittently Operating Propulsion Systems I.....	11
Figure 8 – Intermittently Operating Propulsion Systems II.....	12
Figure 9 – Propulsion through Variation of the Density of the Propellant.....	12
Figure 10 – Reactive Jet-Propulsion Systems.....	12
Figure 11 – Mixing-Nozzle Propulsion Mechanisms.....	14
Figure 12 – Gas-Water Jet Propulsion for High-Speed Vessels.....	15
Figure 13 – Air-Cushion Propulsion for Slow Vessels.....	16
Figure 14 – Beating-Wing Propulsion Systems.....	18
Figure 15 – Comparison of a Pulse Jet Propeller with an Ideal Propeller.....	19
Figure 16 – Pulse Jet Propeller.....	22
Figure 17 – Impulse Propellers (According to Föttinger ¹⁴).....	23
Figure 18 – Vortex Pair (According to Föttinger ¹⁴).....	24
Figure 19 – Circulation Flow.....	25
Figure 20 – Mathematical Model of a Pulse Jet Propeller.....	29
Figure 21 – Ideal Pulse Jet Propeller (According to Föttinger ¹⁴).....	31
Figure 22 – Jet Formation (According to Dickmann).....	33
Figure 23 – Process of Flow in the Suction and Exhaust Stroke of a Pulse Jet Propeller (According to Dickmann).....	33

Figure 24 – Pulse Jet Propeller for Gas-Water Operation.....	36
Figure 25 – Method of Operation of Propeller Shown in Figure 24.....	37
Figure 26 – Simplified Arrangement for the Treatment of the Partition Wall Problem.....	38
Figure 27 – Schematic Drawing of Thrust Tube Arrangement.....	40
Figure 28 – Schematic Drawing of Jet-Nozzle Arrangements.....	43
Figure 29 – Schematic Drawing of Areas Where Losses Occur.....	44
Figure 30 – Model Tests with Jet Propulsion Showing Variation of the Location of the Intake or Exit Cross Sections.....	46
Figure 31 – Results of Model Tests with Jet Propulsion.....	46
Figure 32 – Service Boat with Jet Propulsion.....	48
Figure 33 – Delivery Volumes and Useful Delivery Heads of a 56-Horsepower Jet-Propulsion System.....	48
Figure 34 – Efficiencies.....	48
Figure 35 – Towing Tests and Bollard Pull Tests.....	49
Figure 36 – Planing Boat with Jet Propulsion.....	49
Figure 37 – 230-Horsepower Tugboat with Jet Propulsion (in Design Stage).....	51
Figure 38 – Jet-Propulsion Systems for Shallow-Draft Vessels (According to Basin and Medvedev).....	51

ABSTRACT

This report presents a series of lectures on problems of water jet propulsion given by five prominent scientists at the Research Institute of Hydraulic Engineering and Shipbuilding in Berlin. The lectures include an introduction to the problem of jet propulsion, preliminary investigations, theoretical formulations, and a consideration of various types of jet propulsion.

The report also contains a discussion of the lectures by many of the scientists present.

1. INTRODUCTION

by S. Schuster

1.1 DEFINITION AND STATEMENT OF THE PROBLEM

Every self-propelled vehicle moves forward by utilizing the reaction forces which are being exerted, opposite to the direction of motion, upon the existing or continuously newly created environment. If the environment is a fluid medium, it is partially accelerated by these forces, and a flow is produced whose path is arbitrary with respect to space and time. The only characteristic feature is the existence of a vortex field which encompasses the region of the mass motion. Since this motion is rectilinear on an average, at least in the immediate vicinity of the origin, the designation "jet" appears to be justified.

Hence, all hydromechanical ship-propulsion systems are jet-propulsion systems, regardless of whether the jet is produced by such driving mechanisms as the oar, the water wheel, the screw propeller, the lifting foil propeller with a vertical axis (Voith-Schneider), or the pump. Any distinction in these mechanisms is not clearly defined since the boundaries between them sometimes shift a great deal. Even the fact that the jet-producing mechanism may be located outside the hull or within the ship itself does not furnish an essentially distinguishing characteristic, just as the location of the regions of the inflow to and outflow from the propulsion mechanism is not characteristic.

According to linguistic usage, however, the comprehensive term "jet propulsion" is confined here to a particular group of nonconventional propulsion systems. This is done to emphasize several peculiar features and differences as compared to the conventional propulsion systems. These features will become apparent only when we go into a more detailed explanation. At the same time, this term serves to point to their close relationship and to recognize formally the requirement that any new theories, insofar as they can be applied at all, must also be applicable to the conventional propulsion mechanisms, such as the screw propeller. Conversely, it is true that the advanced development of the theory of the screw propeller provides direction for the proper treatment of the problems of water jet propulsion.

Any systematic investigation must pursue two different objectives. We must investigate the generation of the jet, on the one hand, and the jet itself, on the other; i.e., one time we must investigate an engine and the other time, a vortex street which, in the final analysis, amounts to a separate treatment of cause and effect. The goal of the engineer, of course, is to make predictions regarding the technical usefulness of the propulsion system as a whole and of its efficiency in particular. This includes making a judgment regarding its adaptability to various practical conditions, especially in comparison to the adaptability of the screw propeller.

Such investigations have been carried on in the Research Institute for Hydraulic Engineering and Shipbuilding for quite some time. They were instigated by the Senator for Economic Affairs and Credit Financing from (West) Berlin and the Federal Minister of

Transport with the support of the ERP (European Recovery Program) and the German Research Association. Although these investigations are by no means complete as yet, they have nevertheless been carried to the point where a statement of the problems, the possible solutions, and the preliminary results in connection with their application appears to be advisable.

1.2 OUTLINE OF THE HISTORICAL DEVELOPMENT

Water jet-propulsion systems have been in use on ships almost as long as ships have been propelled by engine power. Busley¹ reported on a British gunboat WATERWITCH which had a length of 49.4 m, a displacement of 1180 m³, and engine power of 760 hp and was equipped with a jet-propulsion system with a radial pump. As early as 1867, this boat traveled at a speed of 9.3 knots. This speed was only 3 percent lower than that of a sister ship of about equal size which was equipped with twin propellers; see Figure 1. While the boat was traveling, the water flowing from the intake opening in the bottom below the center of the ship to the two discharge elbows in the sides of the ship had to cover a distance of about 10 m in each case. Busley's report also refers to the German tugboat RIVAL whose discharge openings, it should be noted, were located above the design waterline (DWL).

The Operation of the jet-propulsion mechanisms in a Swedish torpedo boat, (LILLIEHÖÖK), built in 1878, and in a British torpedo boat (THORNYCROFT), built in 1883 was very similar. Compared to their sister ships, these boats were considerably more maneuverable, but they reached only about 70 percent of the maximum speed of those ships. Characteristic is the use of low-speed radial pumps with long feed pipes to the lateral discharge elbows, which were of the revolving type. In Germany, at about the same time, two smaller freighters were equipped with a "hydro-motor" developed by E. Fleischer by means of which steam intermittently accelerated a water column in the astern direction without inserting any engine whatsoever. Obviously, because of its low efficiency, this propulsion mechanism was later replaced by a steam engine and a screw propeller.

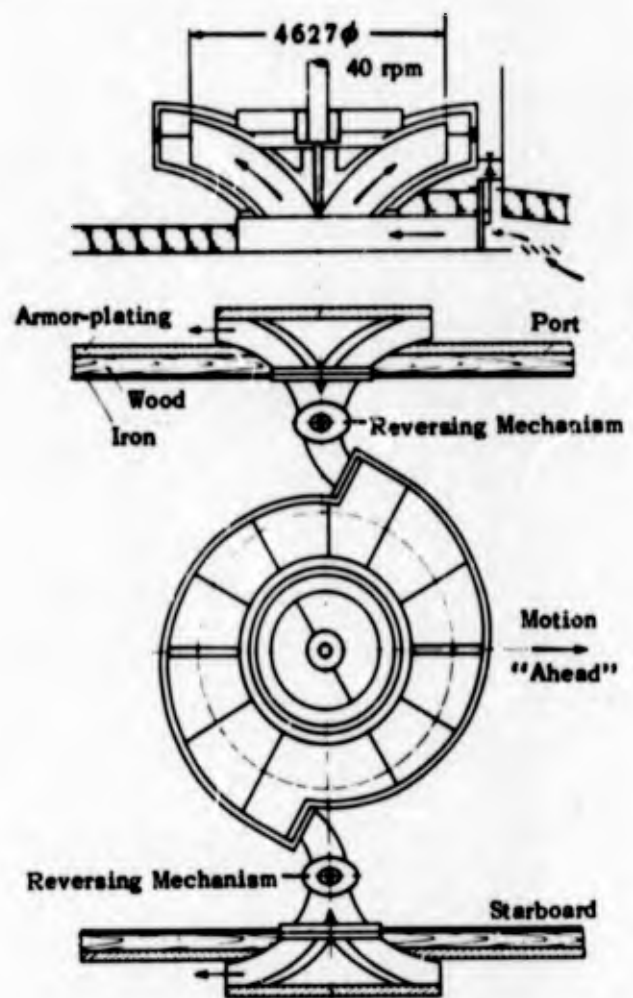

Figure 1 - Jet-Propulsion Mechanism of WATERWITCH, 1867

¹References are listed on page 52.

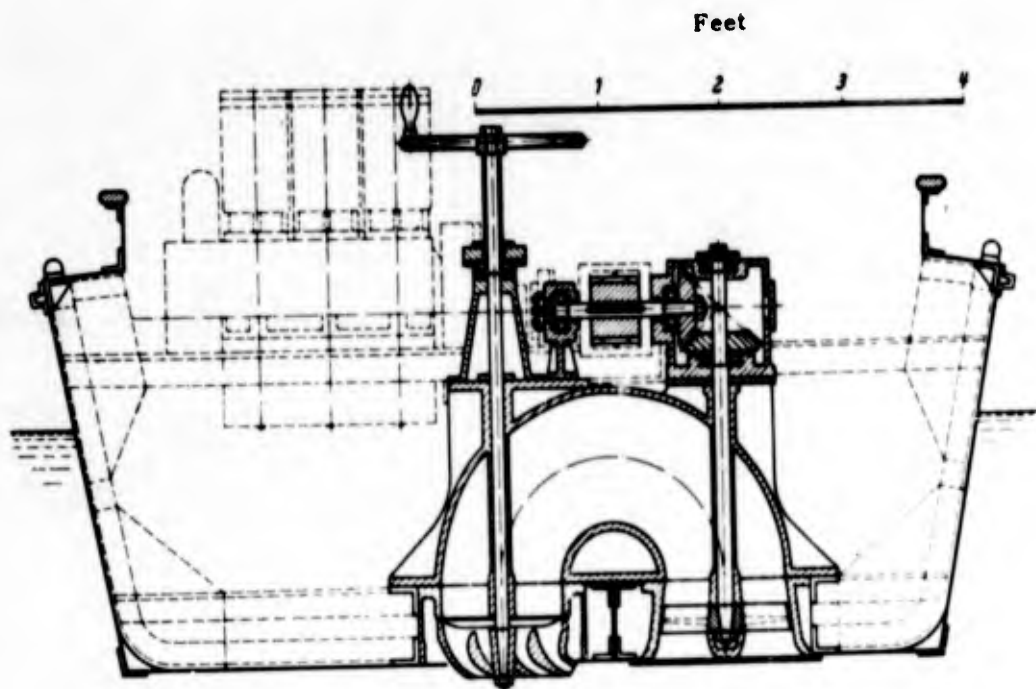

Figure 2 - Gill Jet-Propulsion Mechanism, 1923

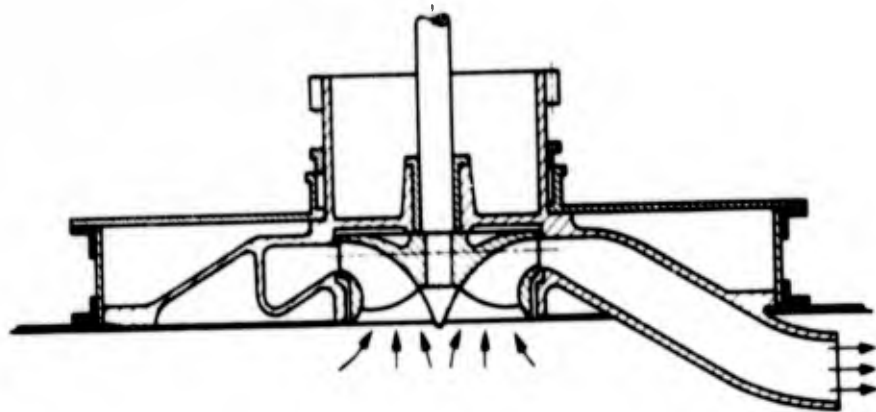

Figure 3 - Nowka Jet-Propulsion Mechanism, 1926, Built Inside the Hull

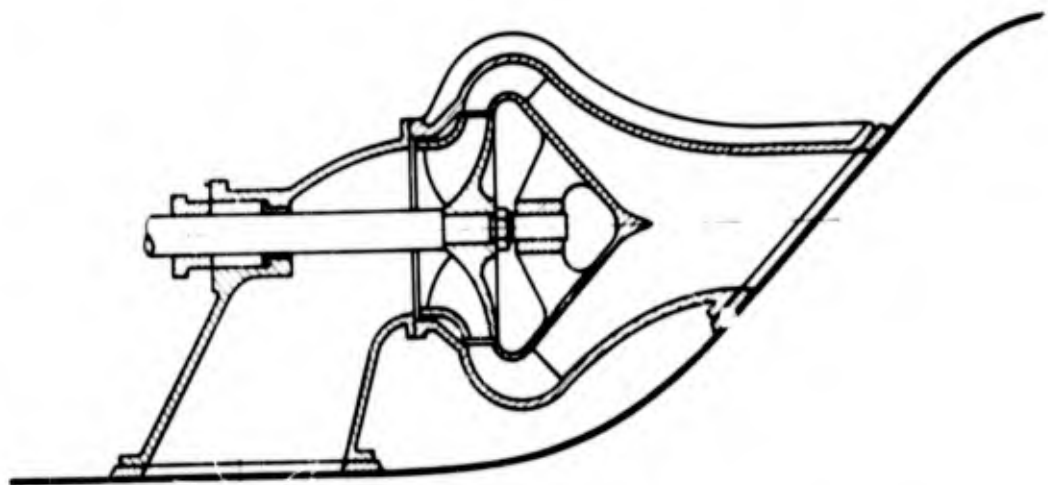

Figure 4 - Nowka Jet-Propulsion Mechanism, 1926

After a few further applications up to the First World War, an intensified campaign to develop jet propulsion was initiated from various quarters about the year 1925. Boerner caused a bit of a sensation with his experimental ship FORELLE. This boat was 9 m long, was equipped with a "Gill propulsion mechanism" consisting of an axial flow pump installed at the bow, a large intake opening in front, and discharge slots on the sides, with an engine output of only 6 hp. Also in 1925, a ferry boat was operated by means of a jet-propulsion mechanism according to the "Gill system," making use of an axial flow pump; see Figure 2. Finally, also built at that time was the first Kort-nozzle tugboat, which was fitted with water ducts running through the hull of the ship. It is a well known fact that in a towrope-pulling contest this tugboat, with an engine power of 120 hp, defeated the 50-percent more powerful, screw-propelled tugboat of the towing monopoly on the Mittellandkanal (canal system in central Germany).

Because of his early successes and the favorable results obtained in model tests conducted at the Hamburg Model Basin, Kort at first continued to use long ducts running through the ship. Meanwhile, as early as 1926, Nowka had proposed a jet-propulsion system which is characterized by a radical shortening of these water ducts. (See Figure 3.) In 1930, Nowka tested an experimental vessel, with a length of 4.5 m and a displacement of 1 m³, on the Oder-Spree Canal, and he attained practically the same speed using an outboard jet-propulsion unit as that attained by an equally powerful outboard motor with a screw propeller. In 1935 when carrying out tests with a diesel-electric drive, which permitted the shifting of the jet generators in the longitudinal direction of the ship, he found that in this particular case the most favorable location with respect to speed was somewhere between a quarter and a third of the ship's length from the bow.

The demand for the shortest possible water ducts characterizes further development. Kort's water ducts in the ship were reduced to a piece of pipe immediately at the axial flow pump, "the nozzle," which he took out of the ship again and placed around the normal stern propeller. In spite of the great success of Kort, Nowka continued to apply the principle he had pursued earlier and tested a series of arrangements with radial flow pumps which were completely built into the vessel and, hence, required considerably less projection below the ship's bottom than did normal screws or shrouded propeller systems. (See Figure 4.)

During the Second World War, the firm of Sachsenberg Bros., Inc., carried out systematic experiments with jet-propulsion systems which demonstrated their fundamental suitability even for low speeds of advance. Tests with mixing nozzles, in which air or steam was used as the medium of the propulsive jet, turned out to be negative, however.

The development of the continuously operating jet-propulsion mechanism has continued more or less unnoticed to this day and is now receiving a new impetus in various parts of the world. Very similar to another proposal by Nowka is the hydrojet propulsion mechanism, developed in the United States in 1956 by the Kermath Manufacturing Co. in Detroit. This unit is designed for working boats with a length of 5 to 6 m and a motive power of 60 hp; its

thrust should fall about 20 to 30 percent below that of a corresponding screw propeller; see Figure 5. Apart from the use of a radial flow pump and very short water passages, however, the small exit, which is obviously constructed in a nozzle-like fashion and is indicative of high jet velocities, should be noted. In England the Dowty-Hamilton propulsion system was produced; see Figure 6a. This system also operated with high jet velocities, but was equipped with an axial flow pump.

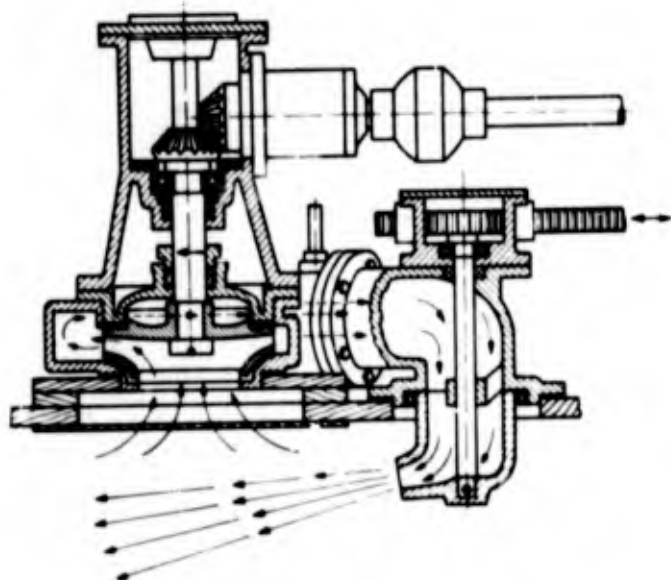

Figure 5 - Kermath-Hydrojet-Mechanism

These jet-propulsion systems are primarily intended for high-speed sport boats, but the German firm of Klein, Schanzlin, and Becker recently presented the KSB-Nowka jet-propulsion system, which was first designed for low-speed boats; see Figure 6b. Further details regarding the present state of development will be given in the last part of this lecture series. Finally, the reader's attention in this connection may also be called to the well-known successes of the bow jet rudders which operate on the same principle.

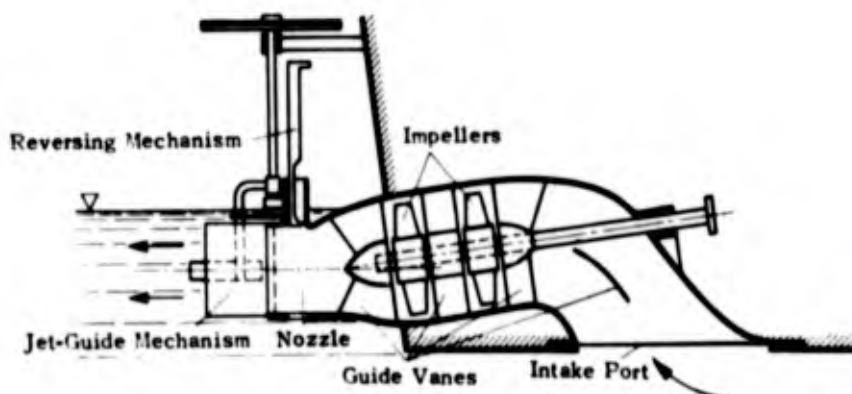

Figure 6a - Dowty-Hamilton Jet-Propulsion System

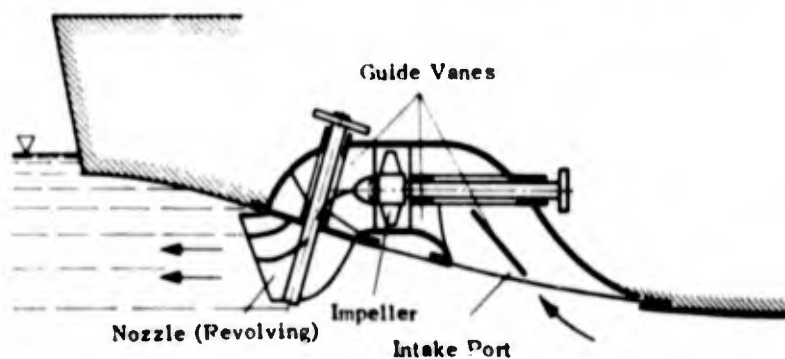

Figure 6b - KSB-Nowka Jet-Propulsion System

Figure 6

Although the experimental data published in the course of this long period of evolution were by no means discouraging, in general, no intensive research work was ever undertaken. It is true that exactly 30 years ago G. Rabbeno² presented before this society, a report on the hydraulic problems of the continuously operating water jet propulsion. Thereafter, however, a long period of silence followed until 10 years ago when H.E. Dickmann³ published his important investigation entitled "Ship Propulsion with Intermittently Operating Propulsion Devices." Unfortunately, his promising research work was interrupted by his premature death.

1.3 ANTICIPATED LINES OF DEVELOPMENT

The fundamental physical conditions which must be taken into consideration in the design of a water jet-propulsion system point the way to its suitable design and application. By accelerating the water flowing toward the propulsion device of a moving ship with the velocity v_p by the mean velocity increment $\overline{\Delta v}$, the mean thrust

$$\overline{S} = \rho \overline{Q} \overline{\Delta v} \quad [1.1]$$

is produced according to the momentum principle whereby energy is constantly imparted to the ship and the water. From the available power, the component

$$\overline{N}_s = \overline{S} v_p = \rho \overline{Q} \overline{\Delta v} v_p \quad [1.2]$$

becomes available for forward propulsion, whereas the component

$$\overline{N}_v = \rho \overline{Q} \overline{\Delta v}^2 / 2 \quad [1.3]$$

remains in the water. If we disregard all other effects, we may thus write the ideal efficiency in the form

$$\eta_i = \frac{\overline{N}_s}{\overline{N}_s + \overline{N}_v} = \frac{1}{1 + \overline{\Delta v}^2 / 2 \overline{\Delta v} v_p} \quad [1.4]$$

or for the case $\Delta v = \text{constant}$

$$\eta_i = \frac{1}{1 + \frac{\overline{\Delta v}}{2 v_p}} \quad [1.5]$$

As a matter of fact, because

$$\text{we get} \quad \overline{\Delta v}^2 > (\overline{\Delta v})^2 \quad [1.6]$$

$$\eta_i (\overline{\Delta v} = \text{const}) > (\eta_i (\overline{\Delta v} \neq \text{const})). \quad [1.7]$$

For hydrodynamic reasons, therefore, for the generation of a certain thrust it would be advisable to entrain as large a mass of water as possible so as to accelerate it as little as possible. Moreover, the continuously operating jet-propulsion mechanism would certainly be preferable to the intermittently operating system, and due importance should be attached to as-uniform-a-velocity distribution as possible within the jet cross section. Obviously, the pipe lines must be kept as short as possible in all cases, and changes in direction must be largely avoided.

However, not only hydrodynamic considerations play a role. Large dimensions require a great deal of weight and reduce the displacement considerably. Low rates of flow at small pressure heads limit the internal efficiency under certain circumstances; moreover, the modern high-speed driving engines call for high revolutions. Since in the final analysis only the economic operation of the entire unit is important, which means that the relationship between the useful load, distance, and time and the cost of investment and fuel consumption are to be considered, other considerations are just as important. This means that, in addition, a compact type of construction, a simple mode of operation – possibly without any special engine – as well as the possibility of easy assembly or addition of structure and good controllability of the jet direction are worth striving for.

As long as the water jet propulsion is more complicated, more expensive, and in the open-water condition more uneconomical than the usual screw propulsion, it must be so variable that for certain special purposes it permits the elimination of unavoidable disadvantages of the screw propeller. Jet propulsion is of interest, for example, if, for towing vessels and icebreakers, it produces greater tow-rope pulls; for working boats, ferry boats, and fishing craft, it creates better maneuvering qualities; and for sport boats, rescue boats, and shallow draft vessels, it offers greater safety. Added to these benefits the substantial advantage of the freer choice of location and of the exceedingly free shape of the jet which could bring about possibilities of reducing wave formation and erosion of river and canal bottoms.

2. SURVEY OF UNCONVENTIONAL JET-PROPULSION SYSTEMS AND SEVERAL PRELIMINARY INVESTIGATIONS

by R. Darnedde

2.1 DESCRIPTION OF PROPULSION MECHANISMS

The number of proposals for jet-propulsion systems made thus far is very large. The following investigation is based on the literature cited in each case and on approximately 200 patents on jet-propulsion systems. The proposals referred to may be arranged schematically; see Table 1. The first distinguishing characteristic is the type of prime mover. We may also differentiate according to the kind of flow produced thereby and, finally, according to the structural characteristics. Among the ways and means of improving the efficiency, which too is logically a part of this subject, are two objectives that must be accomplished; namely, the increase of the entrained mass and the improvement of the jet by making the latter uniform and by reducing the induced velocities.

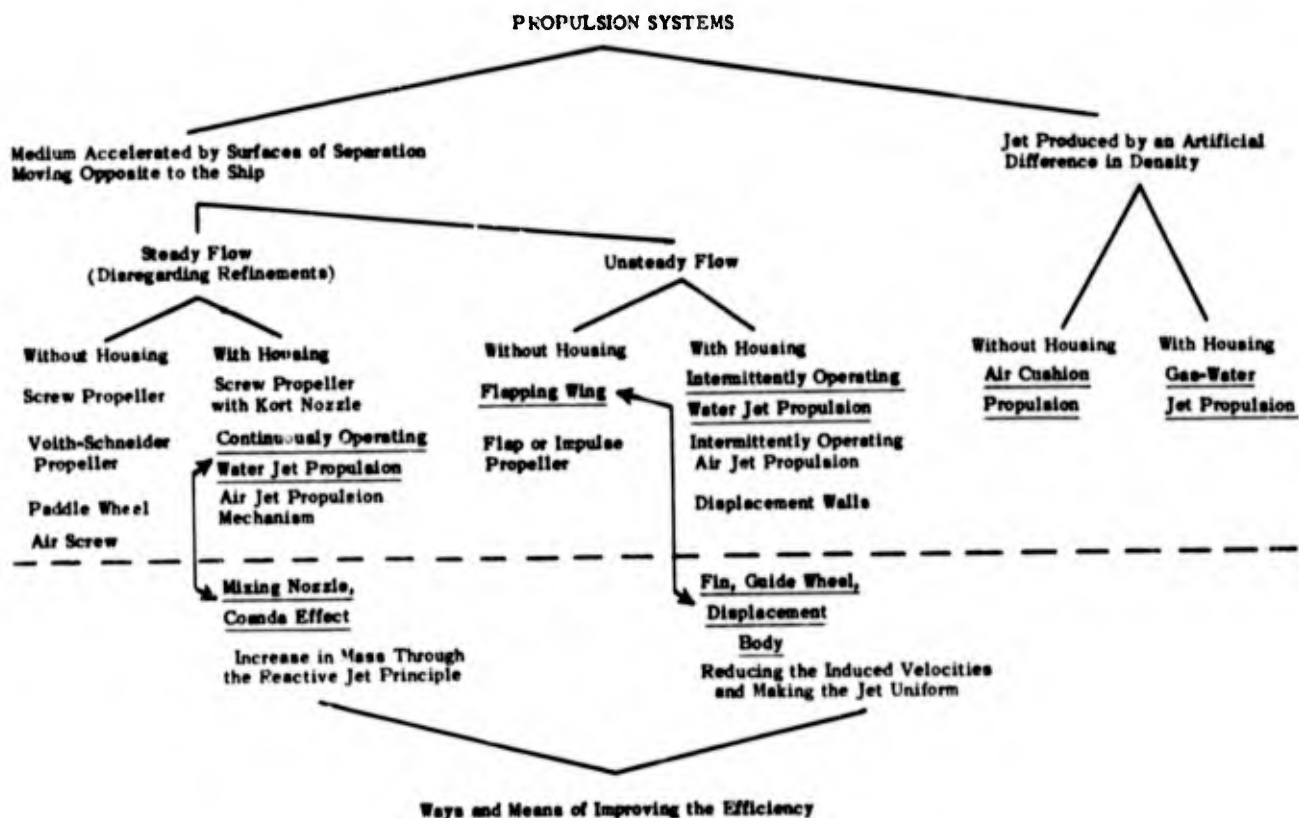

TABLE 1

The diagram in Table 1 would become too complicated if we were to enter all the combinations of jet-propulsion mechanisms and supplementary means which readily come to mind or even only those which have been proposed. The arrows in the table indicate only those mechanisms dealt with here.

To begin with, we will describe the propulsion mechanisms in the same sequence in which they are presented in Table 1; thereafter, we shall consider in more detail those that are underlined. Screw propellers, Voith-Schneider propellers, paddle wheels, air screws, and

Kort nozzles require no further explanation. The continuously operating water jet-propulsion mechanism is characterized by a pump, with delivery and discharge pipes, which is located in the ship and which delivers constant quantities of water. The water is either sucked in through an opening at the bow in the bottom, or drawn in sideways; it is discharged through a smooth pipe, or through fixed or rotatable nozzles. Typical examples of this mechanism are the Dowty-Hamilton propulsion system (see Figure 6a) and the KSB-Nowka propulsion mechanism (see Figure 6b). In the continuously operating air jet-propulsion systems, the operating medium is air rather than water.

The flapping wing represents a propulsion mechanism with unsteady flow. The example of the fins of fishes has frequently suggested such proposals. Skippers of sailing vessels know that in a calm sea the boat can be propelled by turning the rudder back and forth by means of the tiller; see Figure 7a,1. A wing which executes transverse motions has the same effect; see Figure 7a,2. Fins in the wake improve the efficiency; see Figures 7a,3, 4. In the case of the flap or impulse propellers (Figure 7b), the surfaces which are at right angles to the direction of motion during the power stroke displace the water in sternward direction and are recuperated again with as little resistance as possible during the idle stroke. The similarity to the paddle wheel is obvious.

Figure 7c shows several typical water jet-propulsion mechanisms which operate intermittently. The working cycle falls into two parts: (1) During the discharge stroke the water is displaced from the pipe by a piston or by gas and emerges astern in the shape of a jet; (2) During the intake stroke the chamber fills up again and in doing so, the water flows in from all sides. In several patents, even the expulsion by means of expanding fuel gases has been proposed. In this case the combustion is supposed to take place either in special combustion chambers or immediately above the water surface, as we know it from the Humphrey pump. Dickmann³ reasoned that through the unsteady mode of operation, the thrust during the discharge from sharp-edged pipes becomes greater than is to be expected from elementary calculation. Since this phenomenon makes such propulsion systems particularly attractive, we have begun the investigation of this problem. Later during the inspection tour you will be shown a few tests carried out in this direction.

Figure 8 shows pulsating flight jet-propulsion mechanisms and combustion chambers which are similar to the water jet-propulsion systems operating intermittently. In the case of the Argus-Schmidt tube (see Reynst⁴), the pressure on the valve side of the tube increases greatly during the combustion and expels to the rear the gas column inside the tube. Due to the inertia of the mass, gas continues to stream out even when the driving pressure is reduced. The negative pressure produced thereby sucks in a new mixture through the valves and retards the gas column at the same time until the latter swings back and—again through inertia effect—compresses the fresh charge to some extent. Thereupon, combustion sets in and the cycle begins all over again. The propulsion system sketched in Figure 8b (Bertin and Le Foll⁵) operates on the same principle. However, this system is equipped with a hydraulic rather than a mechanical valve which acts as a Venturi tube in the intake

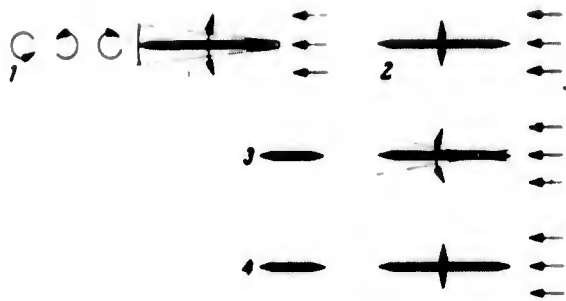

Figure 7a - Flapping Wings (1-4)

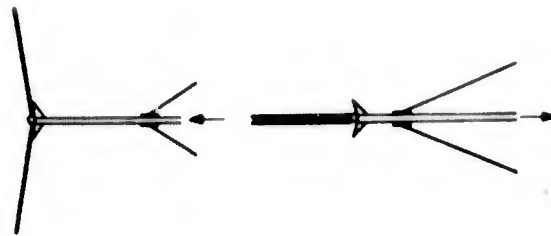

Figure 7b - Flap or Impulse Propeller

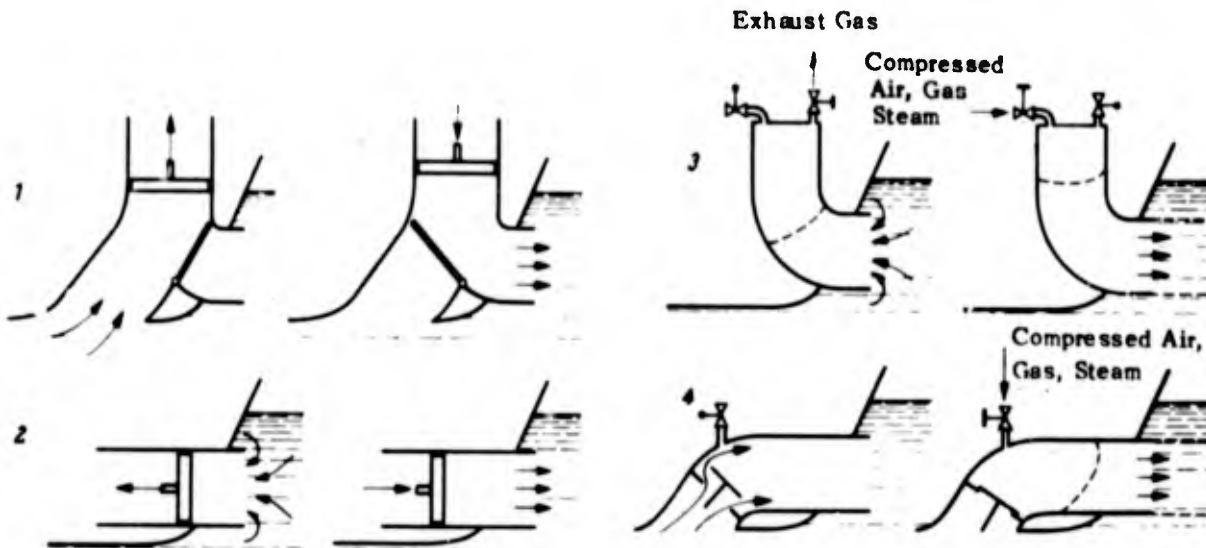

Figure 7c - Intermittently Operating Propulsion Systems (1-4)

Figure 7 - Intermittently Operating Propulsions Systems I

direction and as a discharge tube in the opposite direction, since the flow detaches in the narrowest cross section. Its length is adjusted to that of the discharge tube in order to attain adequate scavenging on the one hand and adequate compression on the other. In the combustion chamber shown in Figure 8c,⁶ intake and discharge take place through the same opening.

The systems shown in Figures 8d and e are characterized by displacement walls. These are moved back and forth in a housing and as they move, they displace the water to the rear and suck in new water predominantly from the front. In these systems, one detects a certain similarity to the propulsion systems which operate intermittently.

In the propulsion systems discussed thus far, the energy is transferred to the water by means of surfaces of separation moving opposite to the ship. In the other main group, it is essential to produce a difference in density, as pointed out before. Thus, in air cushion propulsion systems (Figure 9a for instance) air is conducted into the water with a slight excess pressure. There is formed a mixture of water and air bubbles, with a specific weight lower than that of water, by which a flow is produced as a result of the disturbance of the static equilibrium. The outer skin is formed so that the jet issues to the rear. The reaction of

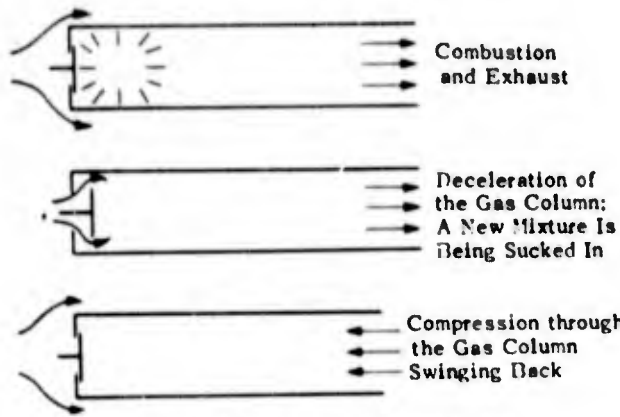

Figure 8a - Argus-Schmidt Tube



Figure 8b - Valveless Pulsating Jet-Propulsion

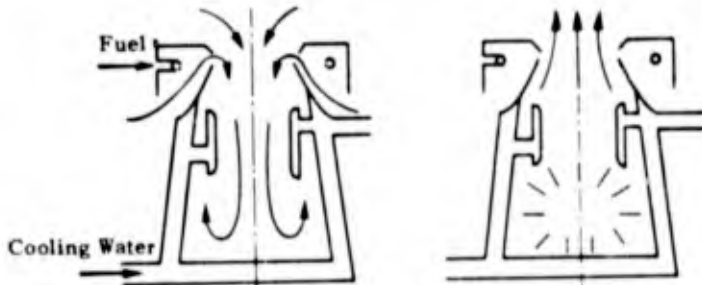

Figure 8c - Pulsating Combustion Chamber According to Reynst

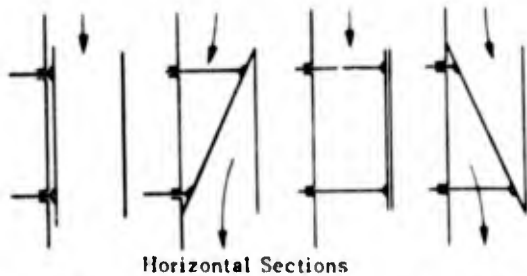

Figure 8d - Wall Exerting a Displacing Effect in a Rectangular Canal Cross Section

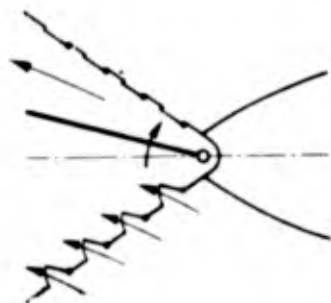

Figure 8e - Rotary Wing Exerting a Displacing Effect

Figure 8 - Intermittently Operating Propulsion Systems II

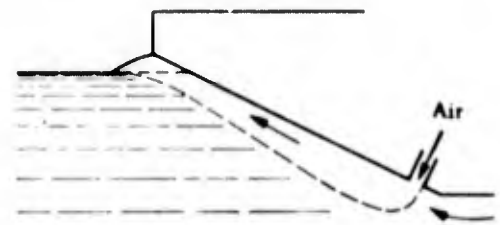

Figure 9a - Air Cushion Propulsion

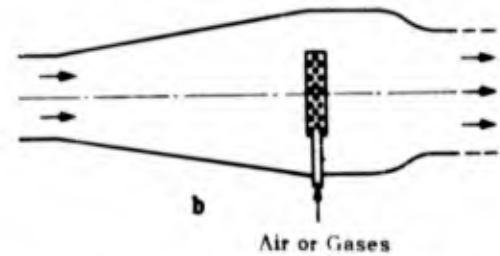

Figure 9b - Gas-Water Jet-Propulsion

Figure 9 - Propulsion through Variation of the Density of the Propellant

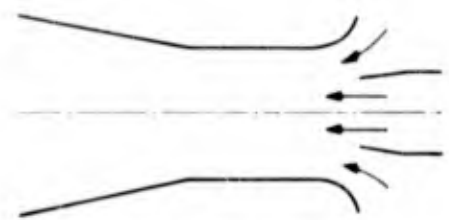

Figure 10a - Ejector



Figure 10b - Mixing Nozzle by Guinard

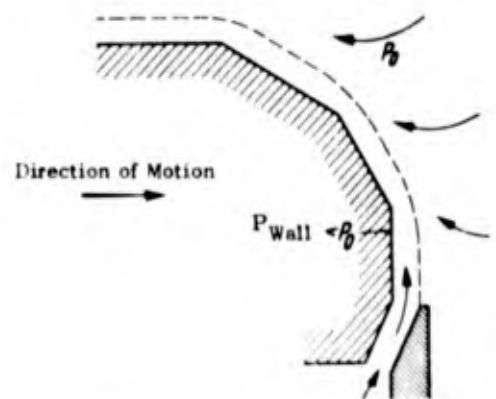

Figure 10c - Coanda Effect

Figure 10 - Reactive Jet-Propulsion Systems

the force required for its acceleration acts as a thrust upon the ship. The gas-water jet-propulsion system (see Figure 9b) is analogous to the thrust tube familiar in the field of aeronautics. The diffusor retards the water entering with the velocity of the speed of advance. Thereupon, air is injected which mixes with the water and thereafter expands in the nozzle. Because of the lower specific weight of the air-water mixture, the exit velocity is higher than the entrance velocity, provided the friction inside the apparatus is not too great.

As previously mentioned, the reactive jet-propulsion principle has been proposed with a view to increasing the entrained water mass. The ejector (see Figure 10a) has been known for a long time; in the mixing nozzle, according to Figure 10b, its principle is applied several times in succession. The Coanda effect (Rader and Schuster,⁷ Rader,⁸ Métral and Zerner⁹) consists of the fact that a skinlike jet emerging from a slotted nozzle and adhering unilaterally to one wall does not break away from the wall at corners that are not excessively convex. On the contrary, the jet continues to follow the contour at reduced pressure and increased velocity. Thus, it may be directed around large angles in several stages, and, in so doing, the surrounding medium flows toward the wall and is carried along to the rear as a result of the reduced pressure. This phenomenon is particularly pronounced in gases, but it also occurs in fluids. According to the proposals made by Coanda, this phenomenon may be utilized for mushroomlike or nozzle-shaped propulsion devices; see Figure 10c.

The means of improving the velocity distribution within the jet are already familiar from the screw propeller theory. The effect of fins used in conjunction with flapping wings, which will be dealt with below, is particularly striking.

2.2 SEVERAL PRELIMINARY INVESTIGATIONS

After this first survey, we may eliminate from our discussion right from the start, several of the propulsion systems, either because of their obviously poor efficiency or because they are similar to others which offer better chances of success. The remaining systems were examined in more detail in our model basin unless previous investigations concerning them had come to our attention. The limited time available makes it impossible to present the derivations. At this time, we will only enumerate the assumptions and indicate the formulas and the results obtained. The latter are illustrated, in part, by concrete examples; the calculations will be published in a separate report.

The most promising principle in our survey appears to be that of the continuously operating water jet-propulsion system. Inasmuch as this system will be dealt with separately later on, it will not be discussed here. Next, the reactive-jet principle is of interest. The efficiency improvement by means of this principle has been investigated for two special cases which are most perspicuous and which also represent borderline cases at the same time; namely, the thrustless nozzle with constant pressure in the mixing chamber and the nozzle with constant cross section. (See Figures 11a and 11b.) Flugel¹⁰ has greatly clarified their

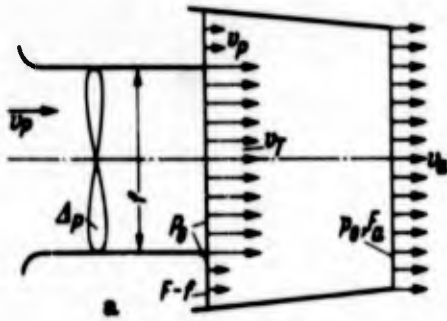

Figure 11a - Mixing Nozzle for Constant Pressure in the Mixing Chamber (Thrustless Nozzle)

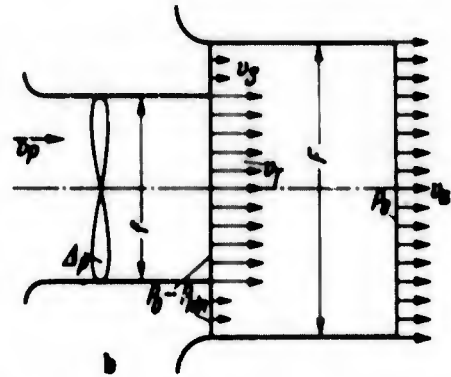

Figure 11b - Mixing Nozzle with Constant Cross Section in the Mixing Chamber

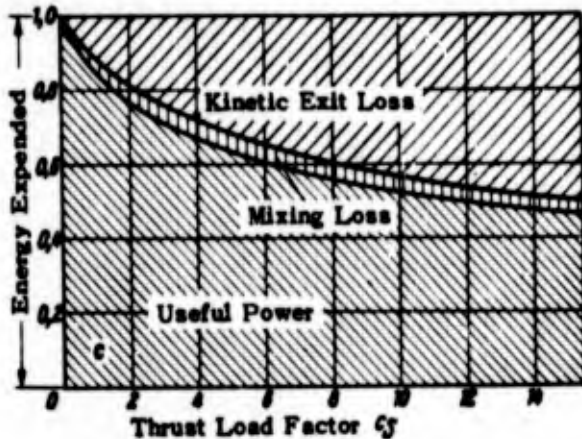

Figure 11c - Ideal Energy Balance in the Case of a Thrustless Mixing Nozzle, $\phi = 1.5$ (Referred to Entrance Cross Section)

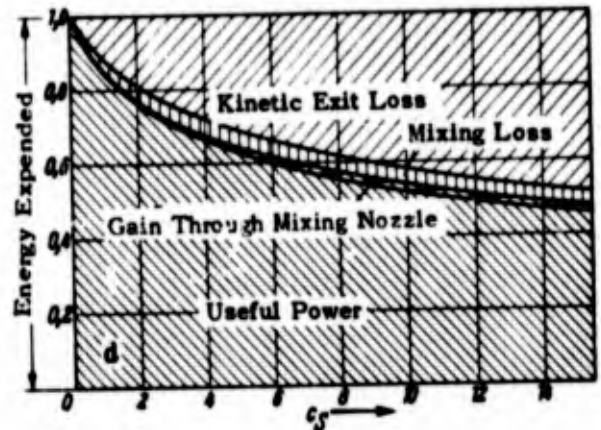

Figure 11d - Ideal Energy Balance in the Case of a Cylindrical Mixing Nozzle, $\phi = 1.5$

Figure 11 - Mixing-Nozzle Propulsion Mechanisms

mode of operation as well as their effective design. A high-velocity jet (the reactive or propulsive jet) entrains the water surrounding it by means of the viscosity forces acting at the boundary surface of the jet. This phenomenon is one which everyone has probably observed in the shipstream of ships. We know that the tractive force retards the propelling jet by withdrawing from it the energy

$$dN_T = dKc_T, \quad [2.1]$$

in the process, while transmitting to the suction jet only the energy

$$dN_s = dKc_s, \quad [2.2]$$

The difference between the two

$$dN_M = dK(c_T - c_s), \quad [2.3]$$

becomes turbulent and passes into the slipstream as impulse loss or mixing loss. This loss is unavoidable. Its magnitude is ascertained by applying the axiom of continuity, the theorem of momentum, and the principle of energy. In connection with the results obtained (see Figures 11c and 11d), a jet generated without loss, a zero wall friction, and a complete mixture, i.e., ideal conditions, are presupposed. The diagrams represent energy balances

plotted against the thrust load factor. Without the mixing nozzle, the kinetic exit loss would be the section above the lowest curve. It is true that this loss is reduced in the case of the thrustless nozzle, but the energy now appears as a mixing loss. In the case of the cylindrical mixing nozzle, we obtain a small gain in effective power in addition to the mixing loss as well as a small increase in thrust. It is likely that the friction largely negates this gain. The improvement is to be attributed to the fact that the water streams into the mixing nozzle at an increased velocity which is due to the negative pressure which occurs in front. Inside the nozzle itself only kinetic loss is converted into mixing loss. A nozzle enlarging to the rear would increase the effective power; however, it is likely that it would fail to achieve its purpose because of the flow separations to be expected.

The conditions to be expected in connection with the gas-water jet-propulsion system

also become clearer if illustrated by a concrete example. Such a propulsion system will be considered for high-speed boats. We shall consider a high-speed boat with a displacement of about 100 tons which travels 42 knots with 17 tons of thrust. If a gas-water propulsion system is to be designed for such a boat, then the conditions in the thrust tube must be determined first; see Figure 12a. The water entering at a velocity of v_p is reduced in the diffuser to $v' = \psi v_p$. The transformation of kinetic energy into pressure takes place with the diffuser efficiency η_d , which

has a pronounced effect upon the quantity of the apparatus and is considered here for this reason. Subsequently, air is supplied at constant pressures p ; this air is supposed to mix with the water homogeneously. The mixture behaves as a compressible medium whose law of compression is derived on the assumption that the air component passes through an isothermal change of state while the water component flows through unchanged. The density of the mixture at atmospheric pressure is

$\rho_{\text{mixture}} = \phi_0 \rho_{\text{water}}$. The equation of motion is obtained from considering the indicated element of volume (in Figure 12a). Finally, we must take into account the draft which exerts a pronounced effect at low velocities. By working out these formulas, we obtain relations for the thrust

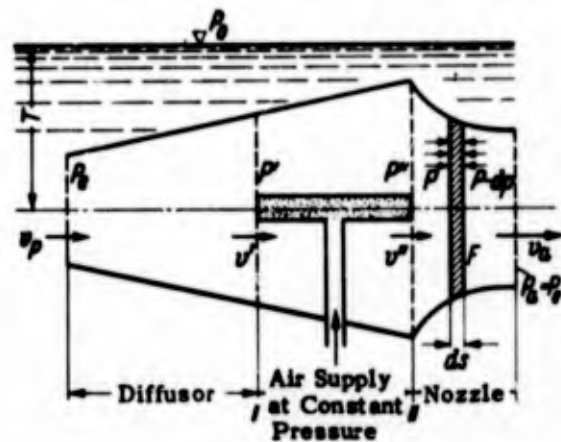

Figure 12a - Diagrammatic Sketch

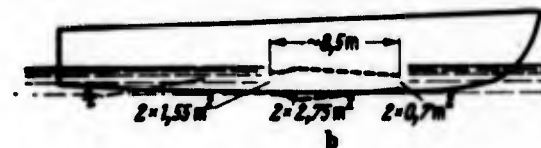

Figure 12b - High-Speed Boat with Gas-Water Jet-Propulsion

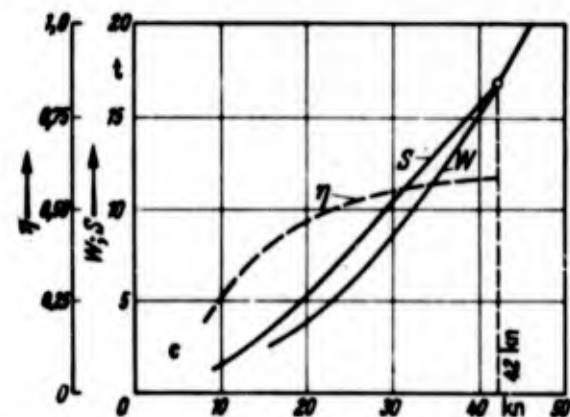

Figure 12c - Resistance, Thrust, and Efficiency

Figure 12 - Gas-Water Jet Propulsion for High-Speed Vessels

$$S = \rho_w Q_{L_0} v_p \frac{\varphi_0}{1 - \varphi_0} \left[\sqrt{\eta_D (1 - \Psi^2) + \Psi^2 + \frac{(1 - \varphi_0) p_0}{\varphi_0 \frac{\rho_w}{2} v_p^2} \ln \left(1 + \frac{\eta_0 (1 - \Psi^2) \frac{\rho_w}{2} v_p^2}{p_0 + \gamma T} \right)} - 1 \right] \quad [2.4]$$

and the efficiency

$$\eta = \frac{S v_p}{\rho_0 Q_{L_0} \ln \left[\left(P_0 + \gamma T + \eta_D (1 - \Psi^2) \frac{\rho_w}{2} v_p^2 \right) / P_0 \right]} \quad [2.5]$$

For the computed example, $\eta_d = 0.75$, $\beta = 0.5$, and $T = 1.2$ m have been inserted, and thrust deduction and wake have been neglected. In this case, a density ratio $\rho_0 = 0.3$ is reasonable. The required dimensions (see Figure 12b) call for more space and weight than a propeller unit.

The thrust characteristic (see Figure 12c) is unfavorable since the available thrust lies but little above the resistance curve. Acceleration is hardly possible therefore. At the operating point, the efficiency lies slightly below 60 percent and decreases as the velocity drops. Moreover, we must not lose sight of the losses in connection with the production and the fine distribution of the compressed air, which have not been taken into account here. The mode of operation of the apparatus explains why one can neither start nor brake nor go in reverse. All in all, this type of drive is probably inferior to the screw propeller unless the mode of operation of the screw propeller is impaired by unusual conditions.

The air-cushion propulsion mechanism will be considered (see Figure 13) on an inland vessel with the following principal dimensions:

Length_{overall} = 60 m
 Molded breadth = 7 m
 Draft = 2 m
 V = 710 m³

v_{service} = 15 km/h \cong 4.16 m/s
 Propeller:
 D (diameter) = 1.30 m
 Area = 1.33 m²

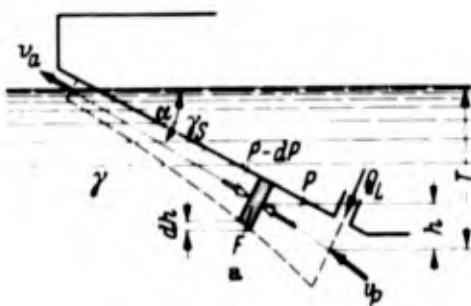

Figure 13a - Diagrammatic Sketch

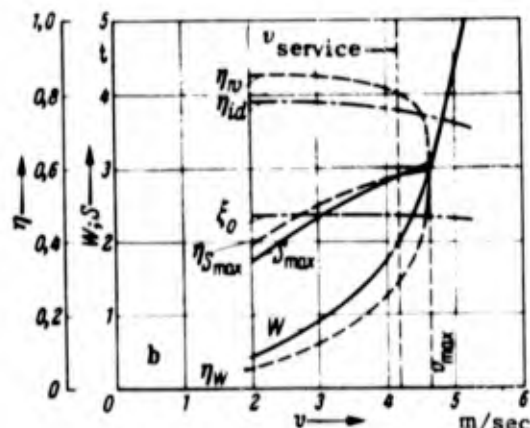

Figure 13b - Resistance, Maximum Thrust, and Efficiencies in a Practical Case

Figure 13 - Air-Cushion Propulsion for Slow Vessels

The resistance and the overall efficiency factor of the propulsion ξ_0 are known from a model test. As we have pointed out before, this type of propulsion is based on creating a static unbalance. The equation of motion is obtained by applying the forces to the jet element as indicated in the diagrammatic sketch. If we assume a homogeneous mixture of air and water as well as zero friction and assume the dash-dot centerline of the jet to be approximately straight and disregard the compressibility of the air, we obtain for the thrust

$$S = \rho_w Q_{L_0} v_p \cos \alpha \frac{\phi}{1-\phi} \left(\sqrt{\frac{(1-\phi) 2 g T}{\phi v_p^2} + 1} - 1 \right) \quad [2.6]$$

and for the efficiency

$$\eta = \frac{S v}{\gamma T Q_{L_0}} \quad [2.7]$$

The thickness of the bubble layer is limited in consideration of the side walls whereas, on the other hand, the full breadth of the ship may be utilized. Disregarding the thrust deduction and wake as well as taking $\cos \alpha \approx 1$, we obtain the curves indicated in the diagram; see Figure 13b. The thrust attains a maximum at a definite mixture ratio of air and water ϕ which depends somewhat on the speed of the vessel. If the air component is made too large, the thrust decreases and the efficiency is greatly reduced. If the air component is made too small, the thrust decreases likewise, but the efficiency increases. In this case, the latter is even better than the pure jet efficiency of the propeller. In this connection, however, we must take into account the losses not considered here, resulting from the production and distribution of the compressed air, as well as the imperfect mixture, the decomposition during the working period, and the thrust deduction, the wake, and the friction. All in all, the efficiency probably lies below the overall efficiency of the propeller unit. Moreover, air-cushion propulsion systems have the disadvantage that the thrust, as a first approximation, varies in proportion to the root of the draft so that in the ballasted condition the thrust is greatly reduced. Finally, the ship can be neither stopped nor reversed under these conditions.

A very clear explanation of the mode of operation of beating wings has been offered by Dickmann;³ see Figure 14a. The ship travels at speed v . The wing moving uniformly back and forth describes the dashed line zigzag curve. The flow striking the wing at a certain angle of attack produces a lifting force with a component S in the direction of motion which represents the thrust and a component T perpendicular thereto which must be supplied by the engine. The angle of attack can only be small and, therefore, T is several times greater than S . This is unfavorable since the useful work $S \times v$ is supplied by a small force at a high velocity, while the engine must supply a large force at a small velocity. Besides, an oscillatory motion takes place so that inertia forces are to be absorbed also. Altogether, high stresses are to be expected.

The figure shows that the wing generates a vortex street behind it. This vortex street must be known in order to calculate thrust and efficiency. A closed solution of the

complicated integral equation resulting in this case can only be obtained at zero load and and with several simplifications. Küssner¹¹ has indicated the solution for the rotary wing and the beating wing, and Schwanecke¹² has done so for the fin. It is true that for a propulsion system, we are interested in finite loads yet even the case solved thus far yields information. Figures 14b and 14c indicate the efficiency for four wing arrangements on the assumption that the wing and the fin have the same dimensions. The efficiency for the wings alone approaches 0.5 at higher reduced frequencies; it can be increased to 1 with the fins. As pointed out before, this applies to zero load and zero friction. The oscillations of the efficiency beyond 1 can probably be attributed to the simplifications of the theory.

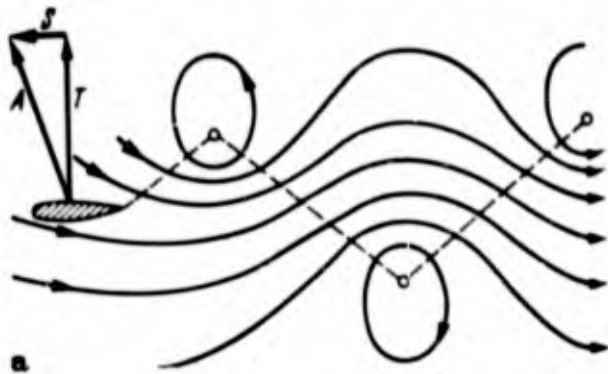

Figure 14a - Mode of Operation (According to Dickmann)

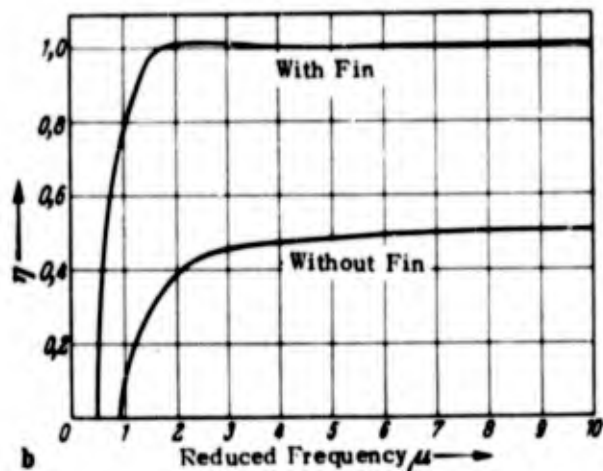

Figure 14b - Efficiency of Rotary Wings

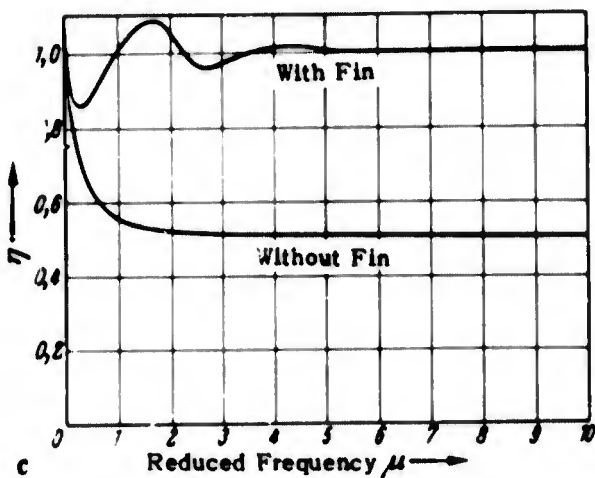

Figure 14c - Efficiency of Beating Wings

Figure 14 -- Beating-Wing Propulsion System

approaches 0.5 at higher reduced frequencies; it can be increased to 1 with the fins. As pointed out before, this applies to zero load and zero friction. The oscillations of the efficiency beyond 1 can probably be attributed to the simplifications of the theory.

We shall investigate, both theoretically and experimentally, the water jet-propulsion systems operating intermittently on the basis of the results obtained from the preliminary investigations and on the basis of the thrust increase due to periodic starting phenomena, as predicted by Dickmann³ and confirmed by preliminary tests. Our goal is to determine the propulsive efficiency and to obtain design data. In regard to definite test conditions, we have chosen a cylinder which is open in the rear with a piston moving back and forth inside in a purely harmonic motion. The water is thus sucked in from the rear and flows, in this case, from all sides toward the opening. It is then expelled again toward the rear in the form of a jet and a circular vortex street is formed. If we assume an ideal fluid and disregard the starting phenomena, the thrust load factor of such an arrangement is about equal to that of an ideal propeller of equal area, if the ratio of the mean piston speed to the velocity of the approach flow is equal to the ratio of the flow velocity of the ideal propeller to the approach flow velocity; see Figure 15a. The efficiency (see Figure 15b) is poorer; this is not surprising since the ideal propeller moves the mass flow $1/2 (v_p + c_k) F$,

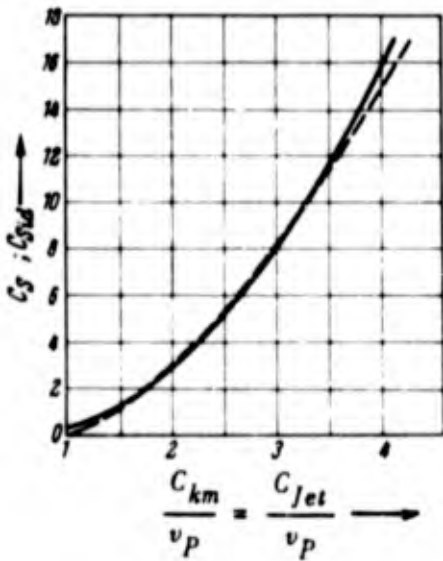

Figure 15a - Thrust Load Coefficients for Equal Area

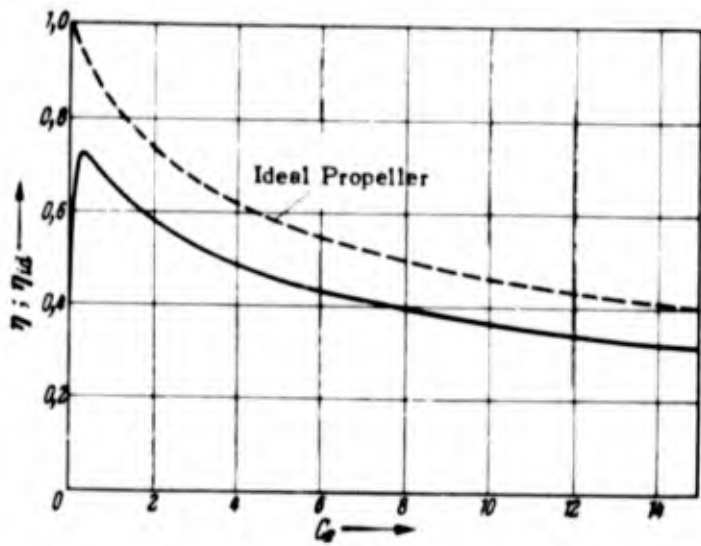

Figure 15b - Efficiencies at Equal Thrust Load Coefficient

Figure 15 - Comparison of a Pulse Jet Propeller with an Ideal Propeller

while the intermittently operating jet propulsion moves only $0.5 \cdot c_k F$. Moreover, as pointed out in the first lecture of this series, the jet efficiency of a propulsion system with a nonuniform jet at equal thrust and equal mass flow is necessarily poorer than that of an ideal propeller with uniform flow.

The results represented in Figures 15a, b would apply if the ratio of the piston stroke to the diameter of the cylinder D is very large. Due to the starting phenomena, the thrust correspondingly increases considerably. At $s/D \approx 3.5$, Dickmann found approximately twice the thrust at zero speed. The question which we intend to answer in the course of our investigation is whether this thrust increase is caused more by the increase in the jet velocity or whether it results more from the increase in the entrained mass. If the latter is the case, it may be expected that the decrease in the jet efficiency shown in Figure 15b compared to that of the ideal propeller at a given thrust and for given dimensions is compensated for, at least in part, at higher load factors. Moreover, a favorable factor in this connection would be that only a part of the total water mass set in motion would have to flow through the apparatus itself. Hence this type of propulsion might be suitable in those cases where large thrusts must be accommodated in a constricted space.

3. THEORETICAL FORMULATIONS

by M. Schmiechen

3.1 INITIAL ASSUMPTIONS

Although a great variety of inventive efforts were made to realize nonconventional propulsion systems for ships, there have been only very sporadic publications of fundamental investigations of the problems to be solved. Noteworthy in connection with these few methodical investigations are the conceptions of the problems and the beginnings made toward their solution. To follow such beginnings we are carrying out in this model basin, theoretical and experimental investigations aimed at obtaining quantitative results suitable for forming the basis of rational design and evaluation methods for pulse jet propellers.

The theoretical studies are confined to the investigation of laminar flows of ideal fluids about hydromechanic reaction devices. In terms of classical hydromechanics, the flow field properties, such as density (and temperature) gradients, molecular and turbulent mixing, which are of secondary importance for the propulsion mechanism, are not taken into account at first. It is assumed, moreover, that the devices exert an arbitrarily periodic effect in unbounded fluids (media) which are generally at rest and that the devices run freely at a constant mean velocity.

3.2 DIMENSIONAL ANALYSIS

In principle, we may distinguish two possible ways of posing the problem. First we may inquire into the mechanisms which produce prescribed flows. This problem is aimed at the design of propulsion mechanisms, i.e., at the solution of the first main problem in terms of H. Schlichting's ideas. Second, we may investigate the effect of certain given devices. This manner of posing the problem amounts to the evaluation of propulsion mechanisms; thus the second main problem is the evaluation of propulsion mechanisms. In any event, we are not really interested in the flows about the devices but in the operating data of the devices. For instance, we are interested in the mean thrust \bar{S} and the mean power \bar{N} at a given velocity \vec{v}_p , the frequency f and dimension l_p of the devices, and the density ρ of the fluids. Assuming the normal case, i.e., resolution of thrust and velocity, we shall not use vector notation in the discussion that follows. For the design of the mechanism, we must also know the instantaneous values or at least the extreme values of thrust and power.

If the quantities \bar{S} and \bar{N} are known for a device as functions of the quantities ρ , v_p , f , and l_p , they are also known for all geometrically and kinematically similar devices. As parameters for the kinematic, dynamic, and energetic similarity of the flows, we may introduce in the familiar manner the coefficient of advance,

the thrust coefficient,

$$A \equiv \frac{r_P}{l_P}$$

and the power coefficient,

$$K_S = \frac{\bar{S}}{\rho l^2 l_P^4}$$

$$K_N = \frac{\bar{N}}{\rho l^3 l_P^5}$$

respectively. The propulsive efficiency

$$\eta \equiv \frac{S r_P}{\bar{N}}$$

the ratio of the mean reaction power of the fluid to the mean power of the device, is associated with the parameters of similitude by the relation

$$\eta = \frac{K_S}{K_N} \cdot A$$

(It is a well-known fact that for the screw propeller,

$$K_N = 2\pi K_M$$

with the moment coefficient

$$K_M \equiv \frac{\bar{M}}{\rho l^2 l_P^5}$$

Offhand, nothing is known about the relationships between the three parameters of similitude A , K_S , and K_N . Only when we consider the fundamental equations of hydromechanics do we arrive at an important general relationship. With correspondingly normalized local velocities \vec{v}_1 and pressures p_1 , Euler's equation and the continuity equation may be represented in the normalized forms

$$\frac{\partial \vec{v}_1}{\partial t_1} + A \cdot (\vec{v}_1 \cdot \nabla_1) \vec{v}_1 = - K_S \cdot \nabla_1 p_1,$$

or

$$\nabla_1 \cdot \vec{v}_1 = 0$$

if the index 1 in this case denotes generally normalized quantities. By eliminating p_1 (Helmholtz principle), we obtain from this

$$\vec{v}_1 = \vec{v}_1(A)$$

and with the expression of the kinematic and dynamic similitude

$$\begin{aligned} p_1 &= p_1(\omega_1): \\ K_S &= K_S(\Lambda) \end{aligned} \quad [3.1]$$

and thereby also

$$K_N = K_N(\Lambda), \quad [3.2]$$

which means that under the assumed ideal conditions, only one of the parameters of similitude Λ , K_S , or K_N is an independent variable. These relationships, familiar from the theory of the screw propellers, apply not only to hydromechanical jet propulsion in general ($S \cdot v > 0$; $N > 0$), but also, formally unchanged, to reaction brakes ($S \cdot v < 0$; $N > 0$) and to reaction motors ($S \cdot v < 0$; $N < 0$).

We should note that for the evaluation of the propulsion systems, it is not sufficient that we know the functions K_S and K_N for a geometrical and kinematic variant. On the contrary, we must also know the functions $K_{S \text{ opt}}$ and $K_{N \text{ opt}}$ which correspond to the envelope curve of the efficiency curves

$$\eta_{\text{opt}} = \eta_{\text{opt}}(\Lambda)$$

for various geometrical and kinematic conditions of the propulsion systems. In detail, therefore, the solution of the second main problem comes down to systematic calculations. Since, in actual practice, we must also know the influences of secondary effects, such as friction and cavitation, we are not interested primarily in the ideal functions but in those which must be obtained from systematic model tests. Only on the basis of such functions is it possible to arrive at rational comparisons of the various types of propellers. A prerequisite of such comparisons is, of course, the comparability of the parameters of similitude. If, for instance,

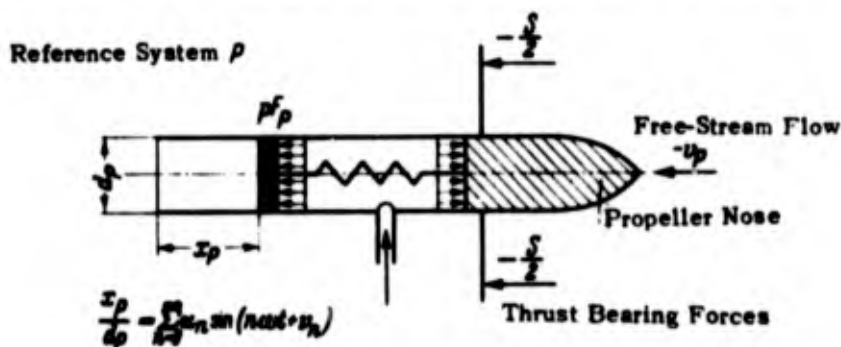

Figure 16 - Pulse Jet Propeller

the pulse jet propellers investigated here (see Figure 16) are to be compared with screw propellers, then the diameters, the stroke frequency, and the frequency of rotation are to be regarded as comparable quantities

As pointed out in the preceding lecture, systematic tests are first carried out with harmonic piston movements

$$\frac{x_p}{d_n} = \alpha_0 + \alpha \sin \omega t,$$

i.e., while varying but two additional parameters.

If in an individual case we are interested in the optimum pulse jet propeller under certain conditions, then the solution of the second main problem is very laborious, if possible at all. Of greater interest in that case is a more expedient and direct design procedure—the solution of the first main problem—whose possibilities and difficulties shall be outlined first.

3.3 ASYMPTOTIC THRUST LAW

Dickmann and Weissinger¹³ furnished a classical example for the solution of the first main problem by setting forth their theory of shrouded propellers. The method amounts to constructing a generating singularity for certain particular flows, so-called jets, of reaction devices. Clear conceptions regarding the propulsion mechanism are the prerequisite for any successful application of this method. The familiar reference to the acceleration of masses and to the reaction which occurs in that case is obviously not sufficient. What do these masses look like? This question was raised by Föttinger in his paper on “Die Grundlagen für die theoretische und experimentelle Behandlung des Propellerproblems” (Fundamentals of Theoretical and Experimental Treatment of the Propeller Problem)¹⁴ which he presented to this Society in 1918.

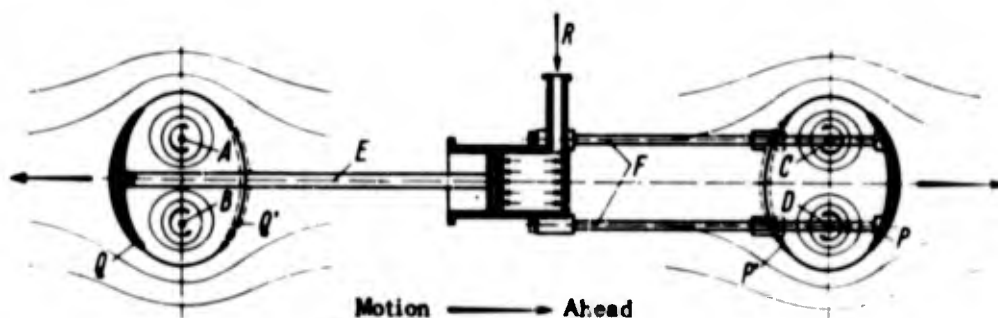

Figure 17 – Impulse Propellers (According to Föttinger¹⁴)

Föttinger considers the starting phenomenon of a ship. His visual model is shown in Figure 17. The impulse propeller Q – Q' produces a vortex ring A – B. The closed “atmosphere” entrained by the latter, here in the form of an ellipsoid, represents the accelerated mass. The impulse of the latter is equal and opposite to the impulse of the craft and of the fluid moved by the latter, which is again conceived as the “atmosphere” of a ring

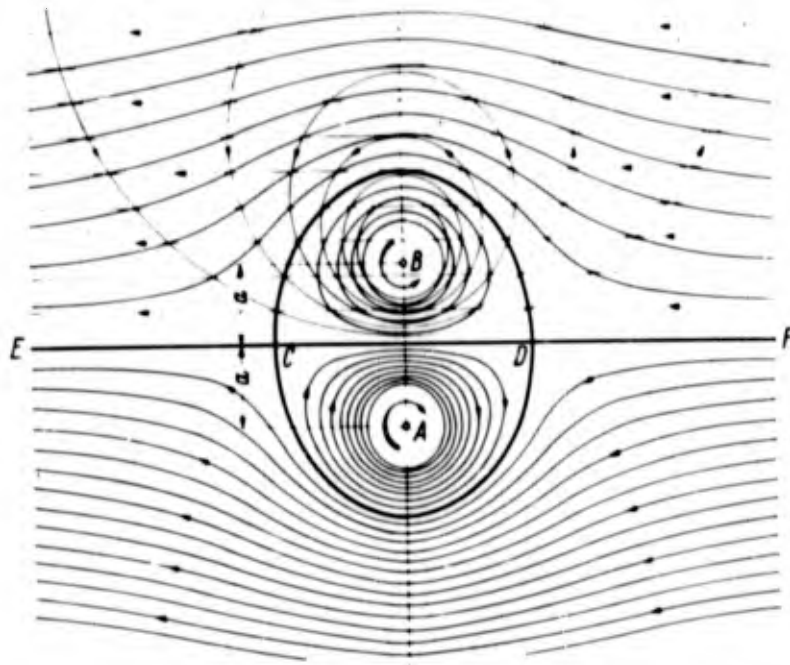

Figure 18 – Vortex Pair (According to Föttinger¹⁴)

vortex (C – D). Figure 18 shows absolute and relative streamlines around a vortex pair, i.e., the streamlines of an analogous two-dimensional flow. The volume enclosed by the dividing streamline moves like a rigid body through the fluid.

As previously mentioned by Mr. Dernelde, impulse propellers produce ring vortex streets; i.e., the starting phenomena just described are repeated periodically. In his article, already cited in the preceding lectures, Dickmann³ pointed to the analogy to the resistance mechanism conceived by Von Kármán. We shall endeavor to show in the following discussion that the realization of the cause-effect relationship between vortex formation and impulse transmission is suitable to form the starting point of a consistent momentum theory. This theory, according to its overall definition, cannot be conceived as an extension of Rankine's momentum theory, although it includes Rankine's theory as a limiting case. The mean thrust of impulse propellers shall be calculated from the data of their developed vortex streets.

If impulses \dot{J} are imparted to a fluid with the frequency f , then the equilibrium condition

$$\bar{S} = -\dot{J} / f,$$

which is obtained by taking the mean of Newton's fundamental law, holds true. However, the impulse of a single ring vortex is

$$\dot{J} = \rho F_G \Gamma_G,$$

if Γ_G denotes the vortex intensity of circulation and F_G denotes the disk area of the vortices (positive direction in the direction of propagation of the vortices, with index G for vortex magnitude).

Thereby, we obtain for the mean thrust,

$$\bar{S} = -\rho \bar{v}_G \Gamma_G l,$$

provided the vortices do not influence each other. The mean (kinematic) jet force is equal to

$$-\frac{\bar{S}}{\rho \Gamma_G} = \Gamma_G l = \bar{\Psi} \quad [3.3]$$

the mean circulation strength of the impulse propeller. In this case, too, the vector characterization is suppressed in the following discussion. The negative sign denotes that the thrust is a force of reaction.

If the frequency f is expressed by the group interval l_G and the group velocity v_{GP} with which the vortex rings are axially displaced in reference system P , which moves at the propeller advance speed; i.e., if we put

we get

$$f = \frac{v_{GP}}{l_G}$$

$$\Gamma_G l = \gamma_m v_{GP} \quad [3.4]$$

with

$$\gamma_m = \frac{\Gamma_G}{l_G}$$

denoting the mean circulation distribution of the jet. This means that f is conceived as the frequency of the vortex exit from the control volume which rests in reference system P and includes the impulse propeller.

To interpret this relation, we shall consider the section through an external pressure jump acting periodically upon a circular surface and through its vortex street; see Figure 19. Of interest are the changes of the vortex flow

$$\Gamma_G = \int_{\Omega} \text{rot } \vec{v} \cdot d\vec{\Omega} = \oint \vec{v} \cdot d\vec{U}$$

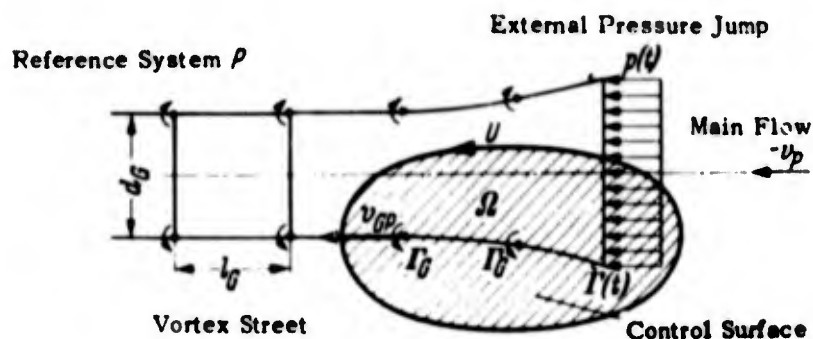

Figure 19 - Circulation Flow

through an arbitrary fixed control surface resting in the reference system P and bounded by the boundary U which encircles a sufficient number of vortex rings.

According to the fundamental law of conservation of vorticity, the acceleration of Γ_Ω is equal to the circulation flow $-\Phi$ over the boundary U of the surface Ω (flow positive to the left) and to the rate of production ψ of the circulation within the boundary U :

$$\frac{d \Gamma_\Omega}{dt} = -\Phi + \psi.$$

It will be found that in the case of periodically unsteady flows, the vortex flow or the circulation Γ_Ω has the same value after each period; i.e., in the mean it remains unchanged:

$$\overline{\left(\frac{d \Gamma_\Omega}{dt}\right)} = 0,$$

in other words,

$$\bar{\Phi} = \bar{\Psi}, \quad [3.5]$$

the mean circulation flow over the boundary is equal to the mean rate of production. The latter has already been introduced, see Equation [3.3]

$$\bar{\Psi} = \Gamma_G f;$$

the former, according to Equations [3.4] and [3.5], is

$$\bar{\Phi} = \gamma_m v_{GP}.$$

This representation deviates in several details from the one which Dickmann developed in his article on periodically operating propulsion devices.³ The deviation is based on the differentiation of the circulations Γ_G and Γ_Ω . Dickmann designates the quantity $\gamma_m v_{GP}$ as vortex flow in contrast to the usage in physics followed here.

3.4 EXTENDED THRUST LAW

If the individual vortex rings enter into interaction with one another, the conditions become more complicated. The jet loading is now greater than the mean circulation production rate:

$$-\frac{\bar{s}}{\rho F_G} = \chi \Gamma_G f = \chi \bar{\Psi} \quad [3.6]$$

With the assumption that

$$\chi = \chi_{1a} = 1 + \frac{v_{GO}}{v_{GP}}$$

Dickmann limits his investigations from the start to vortex streets with an infinitely close succession of the vortex rings. v_{GO} denotes the group velocity of the vortex street in the reference system O which is fixed in the fluid. The function χ is a pure jet quantity, of course.

To regard the quantity

$$\overline{\Delta p} = \rho \cdot \gamma_m \cdot v_{GP}$$

as a mean pressure jump of a fictitious "ideal propeller" of the surface

$$\vec{F}_{P1d} = -\chi \vec{F}_G.$$

i.e., of the contraction ratio

$$\kappa_{1d} = \frac{1}{\chi}$$

is a convenient formalism whose significance must not be overrated. The concept of "propellers" which produce instantaneously complete vortex rings or vortex cylinders, for instance, is a mathematical abstraction which, from a physical standpoint, is altogether problematical. It was precisely the question regarding the origin of vortex cylinders which formed the fertile starting point of the theory of Dickmann and Weissinger.¹³ How do vortex rings originate? This question appears to be the main problem in this connection. Before developing this problem, however, the slipstream theory is to be developed more fully.

The thrust law exhibits one shortcoming—the measurement of the circulation presents difficulties. In analogy to the procedure of Von Kármán, unfortunately, this problem can, at first, be corrected only in a formal manner by introducing a relation for the group velocity v_{GO} . It is a well-known fact that the following approximate formula (see Reference 15, for instance) is good:

$$v_{GO} = \frac{\Gamma_G}{2\pi d_G} i\pi \frac{8d_G}{d_K}.$$

Even the direct measurement of the vortex core diameter d_K , which it contains besides the vortex diameter d_G , actually can be carried out only with considerable difficulty. However, neither the circulation nor the core diameter of the vortex rings need be regarded in any way as being substantially unknown because of these difficulties. The representation of these quantities as functions of the conditions of production is one of the most important problems to be treated in the model basin.

If the circulation is eliminated from the thrust law, then we obtain for the jet load factor, in analogy to the law of resistance of Von Kármán,

$$c_{S^*} \equiv - \frac{\bar{S}}{\rho \frac{v_p^3}{2} F_G}$$

with

$$c_{S^*} = \epsilon \cdot \varphi$$

$$\epsilon = 4 \theta_{GO} (1 + \theta_{GO})$$

$$\theta_{GO} \equiv \frac{v_{GO}}{|v_P|}$$

and

$$\varphi = \frac{1}{\alpha_R} \equiv \frac{1}{\frac{l_G}{\pi d_G} \ln \frac{8 d_G}{d_K}}$$

in the asymptotic case. If the vortex rings exert a reciprocal effect upon one another, say, within the range

$$\alpha_R < \pi,$$

then a more general function

$$\varphi = \varphi(\alpha_R; \theta_{GO})$$

holds good.

It is noteworthy that the quantity α_R represents a purely geometrical parameter of the vortex street. The general character of the function ϕ can be determined readily. The derivation of a usable approximation formula would be of great help in this connection.

The complication in comparison to the problem of Von Kármán is obviously based on the fact that a three-dimensional flow is under consideration in this case. The resistance problem of Von Kármán is also simpler than the propulsion problem under consideration here because in connection with the former, we are merely interested in the thrust power $\bar{S} \cdot v_p$. We are not interested in the mechanical power which is obtainable theoretically when activating a vortex street by a reaction motor and which is lost as a dissipating power in the case of "resistances."

How great are the degrees of power loading and the jet-stream efficiency of ring vortex streets? Thus the question is stated concretely here. Even this question can be answered. The resulting relations have formed the basis for a comprehensive reconstruction of the conceptions regarding hydrodynamic propulsion. Meanwhile, these investigations ought not to be pursued in this connection inasmuch as the development of the momentum theory represents but a preliminary work, although a necessary one, which is expected to lead to the solution of the former main problem. This main problem in precise form now reads as follows: Generating singularities and, finally, equipment are to be constructed to give ring vortex streets.

As of today, this extremely complicated problem is still a long way from its general solution. Even for the vortex street of Von Kármán, it has not been solved as yet.

3.5 MATHEMATICAL MODEL

In this situation, the second main problem assumes a new interest which now reads as follows: What does the vortex street of a given apparatus look like? or How is the process of formation of ring vortices under given conditions to be conceived? The quantitative answer to these questions is precisely the goal of the aforementioned investigations in the model basin.

The consideration of a simple mathematical model of the apparatus represented in Figure 16 indicates that the answer to these questions cannot be avoided. What is conceived is a vibratory single-mass system, corresponding to Figure 20, which moves in an inertial system O at a constant velocity v_p .

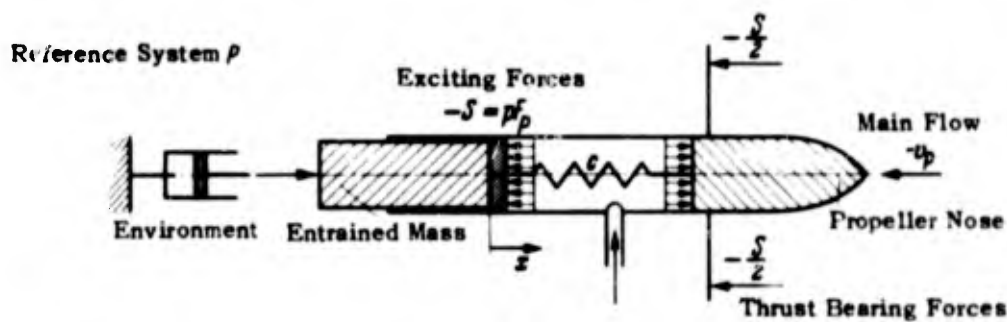

Figure 20 – Mathematical Model of a Pulse Jet Propeller

The equation of the relative pendulum movement is:

$$m \ddot{x} + c x = +(-S) + R.$$

If under the influence of the exciting and damping forces $-S$ or R , respectively, the pendulum executes harmonic vibrations about the original position

$$x_0 = 0$$

with the rotational frequency

$$\omega_0 = \sqrt{\frac{c}{m}}$$

the mass m and the spring stiffness c being constant, then we obtain

$$-S + R = 0,$$

This means that the exciting forces maintain equilibrium with the damping forces, and reactive forces are not to be applied. For the sake of simplicity we shall introduce as the damping law

$$R = \bar{r} \dot{x}_a + r_a \cdot \dot{x}$$

with constant coefficients. For the mean thrust of the apparatus, i.e., the reaction of the exciting forces and the latter's mean power, we thus obtain

$$\bar{S} = \bar{r} \dot{x}_a$$

and

$$\bar{N} = r_a \frac{\dot{x}_a^2}{2}$$

with

$$\dot{x}_a = \omega_0 \cdot x_a,$$

where x_a and \dot{x}_a designate angular deflection and velocity amplitudes, respectively. The propulsive efficiency of the pendulum is therefore

$$\eta = \frac{2\bar{r}}{r_a} \cdot \frac{v_p}{\omega_0 x_a}$$

The formal analysis of the model thus presents no difficulties. The problem lies on a different plane. How large are the coefficients m , \bar{r} , and r_a for a pulse jet propeller?

In the general case, the above-mentioned quantities are certainly not constant; i.e., actually we must consider nonlinear oscillations. In this case, the conditions are determined most conveniently by means of analog devices. However, such investigations cannot assume any significance until concrete data are available regarding the functions m , \bar{r} , and r_a .

3.6 QUASI-STEADY FLOWS

Formulas for the calculation of the thrust of ideal pulse jet propellers which start out from the assumption of quasi-steady flows, in turn, are no less unsatisfactory than the previous ones. In actual practice, the procedure amounts to a plain dimensional analysis.

First, we shall consider a long, ideal pulse jet propeller whose leakproof piston moves at constant velocity; see Figure 21. According to the law indicated previously, Equation [3.6],

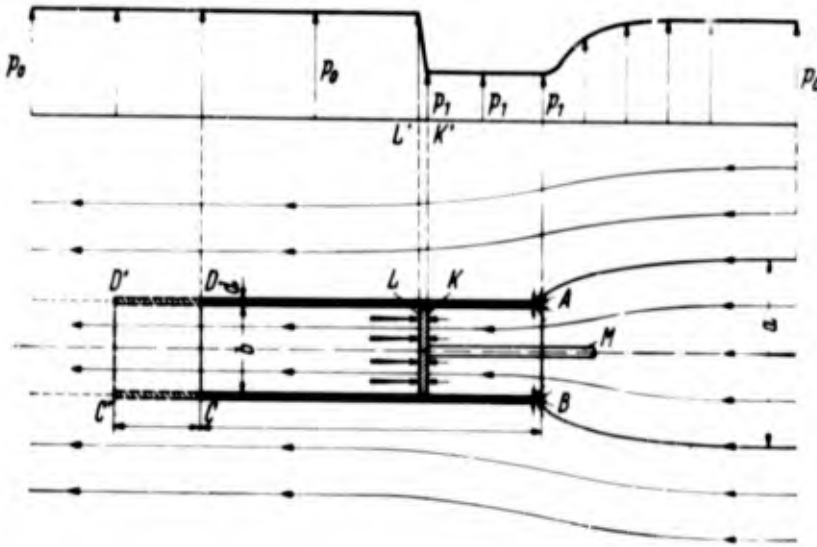

Figure 21 – Ideal Pulse Jet Propeller (According to Föttinger¹⁴)

the thrust of the propeller is

$$S_{id\ tube} = \rho v_K (v_K - v_P).$$

It is a well-known fact that the quantity

$$\chi_{id} = \frac{2 v_K}{v_K + v_P}$$

represents in this case, the thrust increase due to suction forces at the entrance of the propeller (see Reference 14, for example).

If we now assume that the piston speed varies slowly and that the piston transmits completely at a velocity v_K in the direction opposite to the discharge velocity, we can always determine the thrust by simple integration if the law of variation is known. In the fundamental case of a piston moving back and forth at constant velocity, the relation

$$S_e = \frac{1}{2} S_{id\ tube}$$

applies to the mean thrust. The same relation is obtained for a propeller exerting a suction effect from astern.

If the speed variation actually does not take place slowly, as, for instance, at the dead centers in the fundamental case, the concept of quasi-uniform flows is illusory. Due to the effect of the starting phenomena, the thrust increases beyond the value indicated. Dickmann has clearly explained the mechanism of the thrust increase for the fundamental case. The following representation, however, deviates appropriately from that of Dickmann in view of the context.

Starting from the fundamental equation for the thrust, we obtain under practically the same conditions as before

$$\begin{aligned} F_G &= -F_P \\ \chi &= \frac{2v_K}{v_K + v_P} \\ v_{GP} &= \frac{v_K + v_P}{2} \\ \gamma_m &= \frac{v_K - v_P}{2} \cdot \beta \end{aligned}$$

for the mean thrust

$$\bar{S} = \beta \cdot \bar{S}_g \quad [3.7]$$

As a measure of the thrust increase due to unsteady phenomena, we have the normalized mean circulation distribution of the jet. With the circulation distribution γ at the exit of the tube, we obtain

$$\beta = \frac{\gamma_z}{v_K - v_P},$$

where

$$\begin{aligned} \gamma_z &= \frac{1}{s'} \int_{s'} \gamma ds' : \gamma \neq 0 \\ s' &= \frac{s}{2} \cdot \frac{v_K + v_P}{v_K} \end{aligned}$$

Figure 22 indicates the function γ/v_K ($v_K = c_K$) for a stationary propeller. It is obvious that for small values of the stroke ratio

$$\alpha = \frac{s}{d_P}$$

β may accordingly assume considerably larger values than unity. Figure 23 gives a schematic representation of the process of flow in both the suction stroke and the exhaust stroke.

A glance at the list of prerequisites makes the altogether problematic character of the procedure immediately apparent. No solution is offered, for instance, as to what quantity is to be inserted for v_K at variable piston speeds, how large the group velocity v_{GP} is in reality, the contraction ratios

$$\kappa_{1a} = \frac{1}{\chi}$$

and

$$\kappa = -\frac{F_G}{F_P}$$

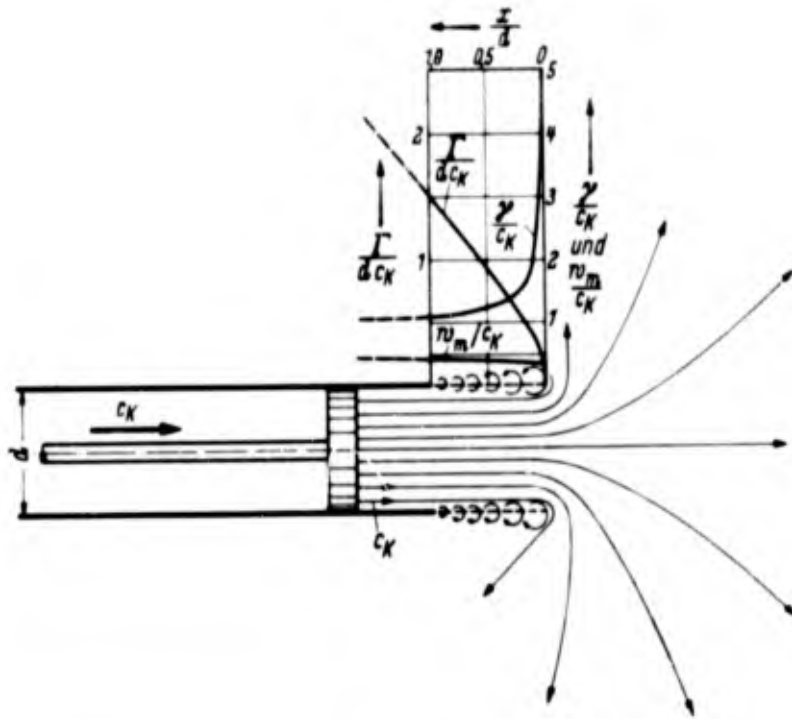

Figure 22 – Jet Formation (According to Dickmann³)

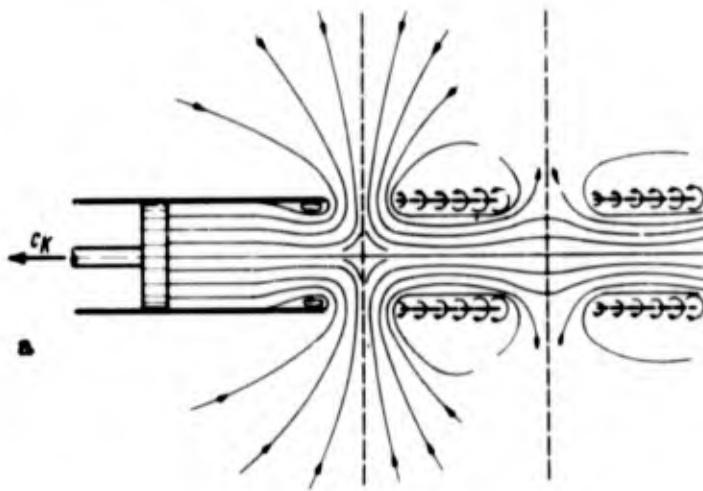

Figure 23a

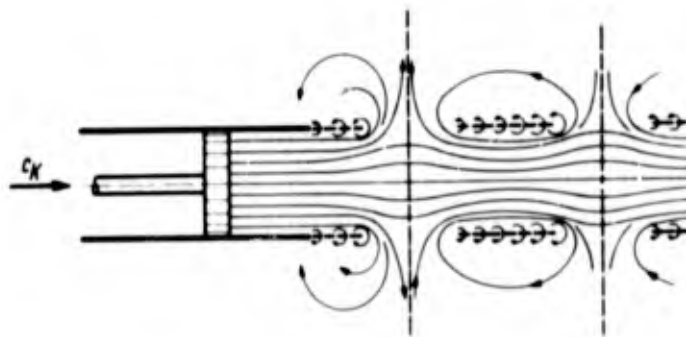

Figure 23b

Figure 23 – Process of Flow in the Suction and Exhaust Stroke of a Pulse Jet Propeller (According to Dickmann)

3.7 A DIRECT FORMULA

The fundamental shortcomings of the foregoing analysis may be eliminated if the law of thrust in its original form, Equation [3.6], with the mean rate of circulation generation, is chosen as a starting point, using the specified definitions, for instance, in the form of

$$\bar{S} = \rho \kappa F_P \chi \Gamma_G / .$$

With the function χ^* defined by

$$\Gamma_G \equiv \frac{\gamma_z^*}{\chi^*}$$

which is similar in character to that of the function χ , we obtain from this:

$$\bar{S} = \rho F_P s / \gamma_z^* \quad [3.8]$$

with

$$\gamma_z^* \equiv \kappa \frac{\chi}{\chi^*} \gamma_z .$$

If, as a first approximation, we put

$$\kappa = 1$$

and

$$\chi^* = \chi$$

we obtain

$$\gamma_z^* = \gamma_z .$$

The approximate thrust law

$$\bar{S} = \rho F_P s / \gamma_z$$

is identical to the law, Equation [3.7], previously derived if

$$v_k = \bar{v}_k = 2 s /$$

and

$$\beta = \frac{\gamma_z}{v_K - v_P} \quad [3.9]$$

are introduced. By means of systematic calculations and experiments, quantitative data are to be obtained regarding the size of β and the limits of the approximate law.

This direct formula for the solution of the second main problem avoids all superfluous concepts and prerequisites. The quantity γ_2^* which appears formally as the velocity increment of the mass flow delivered

$$Q = \rho F_p s f$$

has from the outset nothing to do, of course, with the mean velocity increment of the actually entrained masses. These masses were not considered at all in the considerations carried out thus far.

3.8 RETROSPECTION

A review of the prerequisites shall form the conclusion of this summary of theoretical formulas for the treatment of the pulse jet-propeller problem. The process of the formation of ring vortices has been recognized as being problematical. How do the quantities factored out at first as secondary quantities affect the mode of development of the vortices? Is their influence really of a secondary nature? We know that density gradients do not play any part in connection with hydromechanical propulsion unless we aim at its artificial generation. Its effect upon the formation of vortices is governed by the theorem of Bjerknes (see Reference 16, for instance).

On the other hand, there can be no doubt that the influence of the viscosity effects on the vortex formation are of great importance. To what extent do these effects obscure the details of the process of vortex formation? Is the function β perhaps independent of the law of motion of the piston, at least within the range of practical interest?

The list of problems has not been exhausted by these few remarks. For instance, thus far, we have not even touched upon the complicated stability problems. For practical evaluation of pulse jet propellers, we must also find answers to the problems concerning the effects of conditions of installation and of operation in restricted channels upon the vortex formation and the vorticity transport. The theoretical possibilities and difficulties are well known (see Reference 14, for example).

It is true that such difficulties will complicate and retard the investigation and the utilization of pulse jet propellers, but they will not prevent them.

4. IMPULSE TUBE WITH INTERMITTENT GAS-WATER OPERATION

by H. Schwechheimer

4.1 FUNDAMENTAL FACTS ABOUT THE METHOD OF OPERATION

The purpose of the pulse jet propeller under consideration here is to utilize the energy liberated from the combustion of liquid fuel with atmospheric oxygen as directly as possible to accelerate water for ship propulsion. Through this simplification of the technique of operation, a few of the requirements set up in the beginning may presumably be fulfilled, viz., those of reducing weight, space requirements, and costs.

If fuel is burned at constant pressure, the temperature rises and the volume of the combustible gases increases. This increase in volume is utilized, for instance, in the pressure jet-propulsion mechanism of airplanes, but it appears to be unsuitable for the acceleration of water. If, however, the fuel-air mixture is burned in a closed chamber, then temperature and pressure increase. The gas pressure can now be utilized directly to accelerate the water. To this end the following procedure may be used with highly compressed gases:

Fuel is injected into a combustion chamber scavenged with compressed air (Figure 24) and burned at constant volume. As soon as the combustion is completed, the outlet of the combustion chamber opens into a water-filled tube arranged below the waterline. This tube is open in the astern direction and is closed intermittently directly in front of the combustion chamber exit by means of a mechanical or hydraulic check valve. The highly compressed combustion gases expand and accelerate the water in the tube (propelling water) by acting as a piston and driving the water astern out of the tube, thus generating thrust. The scavenging of the combustion chamber begins when the gas pressure drops below the scavenging air pressure. When the scavenging is completed, the combustion chamber outlet closes. The scavenging air remains in the combustion chamber until the next injection; thus it cools the walls. If the gas pressure in the thrust tube has fallen below the pressure in front of the check valve, the check

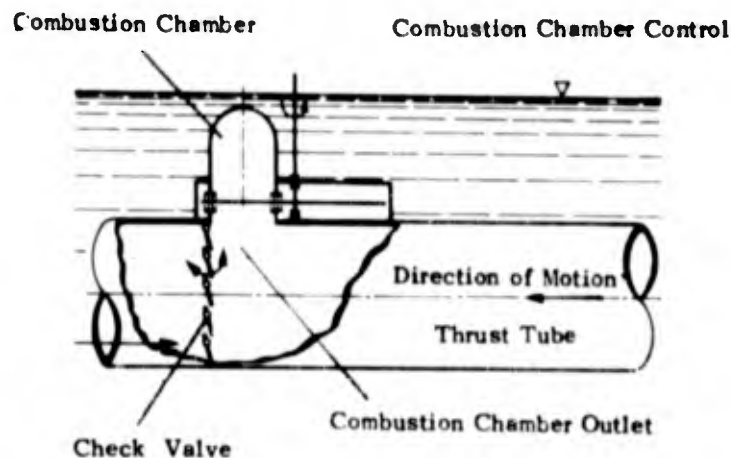

Figure 24 - Pulse Jet Propeller for Gas-Water Operation

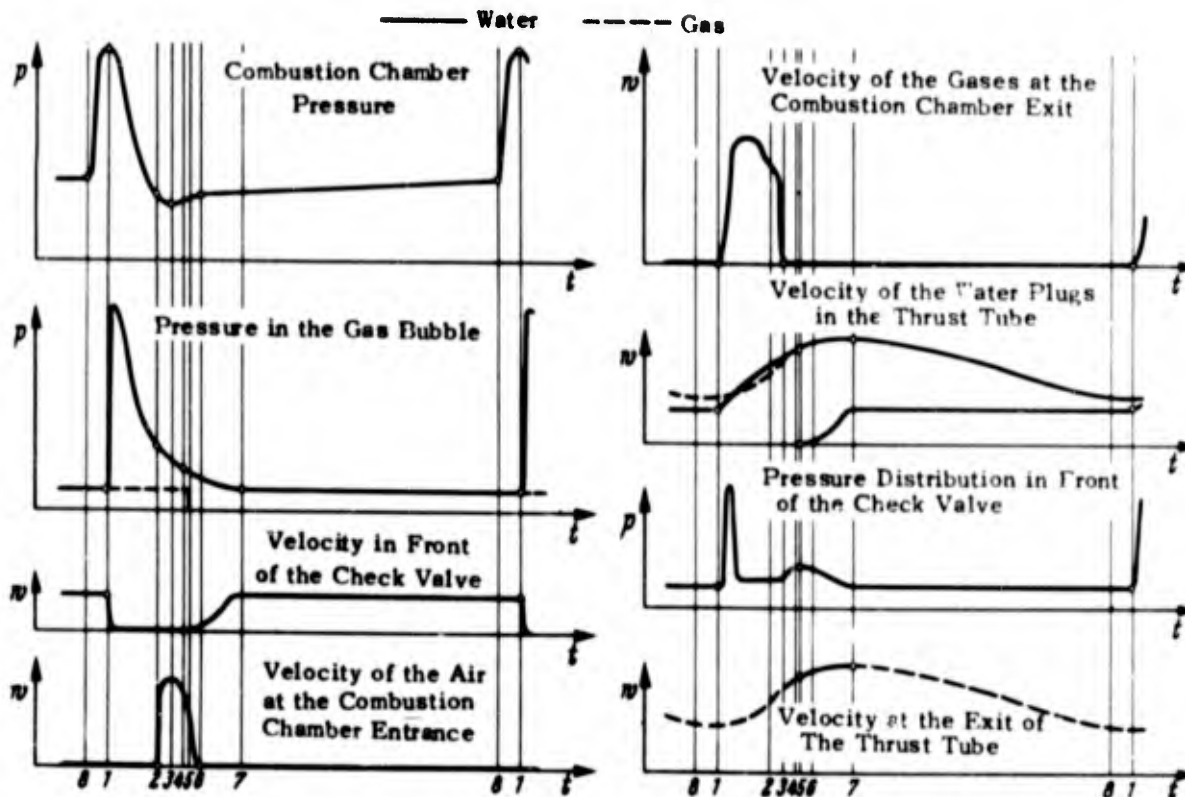

Figure 25 – Method of Operation of Propeller Shown in Figure 24

valve opens and a fresh supply of propelling, driving water enters into the thrust tube from the front. The fuel injection is controlled so that the maximum pressure of the combustion gases is reached at the same moment that just enough fresh propelling water for the next stroke enters the thrust tube. The residual gases of the preceding stroke, which still remain in the rear end of the tube, are expelled by the new plug of propelling water and need not be considered as being in the tube, since their density is small.

Figure 25 gives a schematic representation of the most important pressure and velocity distributions as a function of time t . In this connection, it should be noted that the numbers 1 through 8 indicate marked points of time which permit a coordination of the curves. The lengths of the individual intervals are indicated only schematically. The individual stages take the following course:

1. The combustion chamber pressure reaches its maximum value; the combustion chamber exit opens, and the exhaust gases begin to emerge into the tube. There now forms in the tube a gas bubble whose pressure quickly increases to the pressure of the combustible gases in the combustion chamber. The acceleration of the propelling water begins. At the same time, the check valve in the tube is being closed, and temporarily the water pressure in front of the check valve increases sharply.

2. The pressure in the combustion chamber drops to the scavenging pressure. The combustion chamber entrance opens, the scavenging air begins to enter and to expel the residual gas from the combustion chamber.

3. The combustion chamber exit closes. The combustion chamber is charged up to the scavenging air pressure.
4. The pressure of the gas bubble drops to the pressure in front of the pressure relief valve. The latter opens and the new water plug begins to stream in, whereby the small mass of water accumulated in front of the check valve is first accelerated.
5. The preceding gas bubble expelled and new propelling water begins to enter.
6. The pressure in the combustion chamber is equal to the scavenging air pressure. The scavenging air intake is now closed. The pressure in the combustion chamber increases slowly because of the transmission of heat from the walls to the scavenging air. The combustion chamber is in a standby position until the new fuel injection occurs.
7. The propellant water which began to emerge at Item 5 now leaves the end of the tube and the expanded gas begins to emerge.
8. Fuel is again injected into the combustion chamber which is in a standby position, and a new cycle of operations begins.

4.2 THEORETICAL CONSIDERATIONS

Water masses are to be accelerated by the apparatus just described. To determine this process mathematically, we shall set up a formula according to Newton; see Figure 26. Inasmuch as the derivation and discussion of the formulas which finally result therefrom would go beyond the scope of this paper, we intend to publish a special report to deal with this matter in detail.

During the theoretical considerations, we encountered the following problems: Description of the motion of the gas-water partition as a criterion for the process in the thrust tube; combustion process leading to the selection of the control system of the pressures and temperatures and of the control; heat transmission coefficients and coefficients of friction; design of the combustion chamber; flow pattern at the exit of the thrust tube; and water passage.

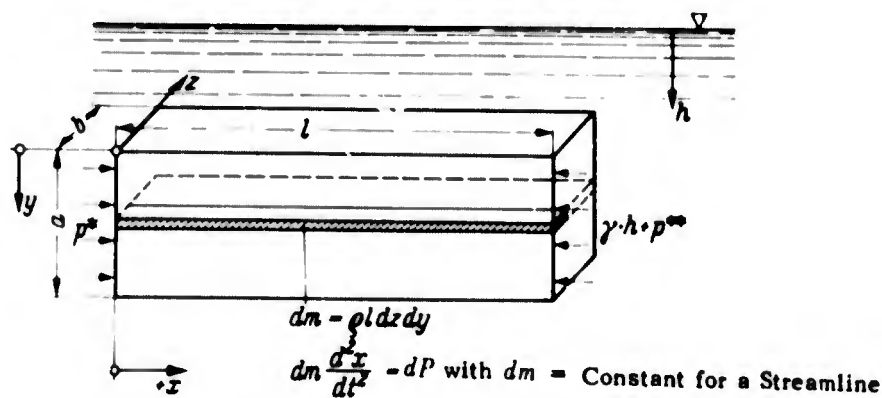

Figure 26 – Simplified Arrangement for the Treatment of the Partition Wall Problem

These problems overlap and intermix a great deal. Here, we can throw some light on only a few points.

Of importance for the procedure here described is the occurrence of a closed partition wall between propellant gas and propelling water, as demonstrated experimentally by Dickmann.

With a few simplifications, which are either customary, in part, or supported by preliminary tests,^{3, 17, 18} we are able to derive formulas for the motion of the partition on the basis of the above-mentioned arrangement. Here, we figure on streamlines which retain the length of the thrust tube over the entire stroke. Into the relations thus obtained, we could introduce the effects of the flow at the end of the tube, and of the gas expansion, including the heat losses. Moreover, we could introduce the effect of the frictional losses into the installation, as well as the inflow losses, as soon as they become available in the form of formulas and numerical quantities. Unfortunately, we encounter great difficulties in doing so.

A determinant for the magnitude of the instantaneous acceleration of the propelling water is the difference between the pressure of the propellant gas and the hypothetical counterpressure which acts at the rear end of the column of propelling water to be accelerated. The temperature of the propellant gas is merely a measure of its potential energy.

For a low weight per horsepower and a small space requirement per horsepower, a high operating frequency based on high gas pressures, is required. Also it should be noted that the flow conditions in the thrust tube (nonuniform flows during a change of water and gas plugs) probably lead to fairly high heat transmission coefficients. Hence, any change in the gas temperature is always connected with an increase of the heat losses, whereas a higher operating frequency presumably reduces the heat losses.

To select the gas pressure, it is necessary to carry out an efficiency analysis with a view to the available power units. For an isentropic process of comparison, this analysis is relatively simple. The optimum pressure must be estimated by taking into consideration the above-mentioned effect of the operating frequency and the conditions at the emerging jet as well as structural aspects. Apart from considering these structural difficulties, we are, in so doing, confronted with a pressure which, according to the present state of our investigations, lies a little above the optimum pressure of the isentropic process.

The coefficients of heat transmission in connection with the flow conditions in the thrust tube are as yet unknown. For the purpose of rough calculations, comparative values are to be estimated according to similar phenomena; see References 19 through 23. This procedure also applies to the frictional coefficients whose effect upon the efficiency of the installation, however, is estimated to be considerably smaller than the effect of the heat losses; see References 23 through 27.

The combustion must take place in a combustion chamber separate from the propelling water. This problem was recognized and investigated by Knappe.^{28, 29}

Experiments, during which the combustion takes place in a chamber which also contains water, as in the case of the Stauber turbine or the Humphrey pump,³⁰⁻³² produced unsatisfactory results. This was due to the fuel condensing, in part, when coming into contact with water,

which led to an incomplete combustion and to a marked fouling of the installation. Hence, an explosive combustion chamber is suggested for the generation of the propellant gas. This chamber should be scavenged under a relatively high pressure which may be determined according to the line of reasoning given in the preceding chapter. In this case, the process taking place in the combustion chamber must be controlled so that the pressure in the chamber never falls much below the scavenging air pressure.

Explosive combustion chambers are not a new structural element; see Holtzwarth.³³ For this type of combustion chamber, however, we are not able to draw upon such an extensive fund of experience as in the case of constant-pressure combustion chambers and the combustion in the diesel engine. Nevertheless, we can easily demonstrate that the combustion in a purely explosive combustion chamber takes a more favorable course for the total process than in the two types of combustion just mentioned after the initial practical difficulties have been overcome.

The flow pattern at the exit of the thrust tube is not yet known. Inasmuch as research work is being conducted in this area, we may hope that tentative values, at least, will become available in the foreseeable future.

The water passage is essential to an efficient installation. The water which streams into the tube in a direction opposite to that of the direction of motion is allowed to lose as little as possible of its kinetic energy. Once the water is in the thrust tube, the acceleration through the propellant gas must set in without any waiting period if possible. Since the propelling water enters intermittently into a thrust tube, it is advisable to arrange several tubes parallel to each other and to feed them with water through a common entrance opening. This water intake must project from the outer skin "in a mouth-shaped contour" similar to that of the intake openings of various jet planes so that the water may enter the tube as uniformly as possible in the direction of motion and not perpendicularly thereto. Both the further passage of the water from the entrance opening to the check valve and any possible control of the check valve must take place so that the portion of water being accelerated either negatively or positively in front of the check valve when it closes or opens is as small as possible. In this connection, the surplus masses of water in each case are to be deflected without any appreciable loss. The water duct as well as the thrust tube must be designed to be as short as possible to keep the frictional losses down. Corners are to be avoided.

These reflections have led to several theoretical beginnings for carrying out the calculation of examples with simplified assumptions. According to these theories, it seems likely that for certain areas of application the thrust tube is able to compete with the screw propeller; thus continued investigations are justified.

Figure 27 gives a schematic representation of the installation of a thrust tube unit into a vessel.

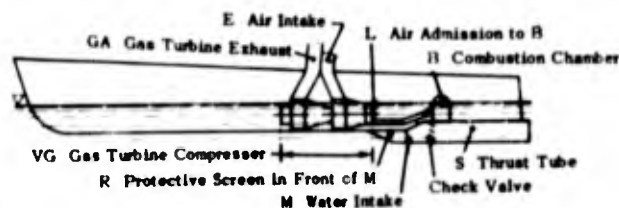

Figure 27 - Schematic Drawing of Thrust Tube Arrangement

5. CONTINUOUSLY OPERATING JET-PROPULSION SYSTEMS

by H. Schwanecke

5.1 GENERAL REMARKS

A continuously operating free-running jet-propulsion mechanism with an exit cross section F_A and a jet exit velocity v_A , opposite to the direction of motion and assumed to be parallel, generates a thrust of magnitude

$$S = \rho F_A v_A (v_A - v_P) \quad [5.1]$$

and a thrust power

$$N_S = S v_P = \rho F_A v_A (v_A - v_P) v_P \quad [5.2]$$

if the surrounding medium at the location of the jet exit has the velocity v_P . As a result of the generation of propulsion, there occurs a jet loss of the magnitude of the kinetic energy of the jet

$$N_{VA} = S \frac{v_A - v_P}{2} = \rho F_A v_A \frac{(v_A - v_P)^2}{2} \quad [5.3]$$

The jet power to be produced by the propulsion mechanism then has the magnitude

$$\begin{aligned} N_{td} &= N_S + N_{VA} \\ &= S \frac{v_A + v_P}{2} = \rho F_A v_A \frac{v_A^2 - v_P^2}{2} \end{aligned}$$

or

$$N_{td} = \frac{1}{\eta_{td}} N_S \quad [5.4]$$

with the jet efficiency

$$\eta_{td} = \frac{2 v_P}{v_A + v_P} = \frac{4}{3 + \sqrt{1 + 4 S / \rho F_A v_P^2}} \quad [5.5]$$

If the magnitude of v_P or F_A , respectively, is known, we obtain from Equation [5.1] the water mass per second to be accelerated for the generation of a specified thrust viz.,

$$Q = F_A v_A = F_A \cdot \frac{v_P}{2} \left(1 + \sqrt{1 + 4 S / \rho F_A v_P^2} \right) \quad [5.6]$$

The magnitude of the jet efficiency is determined by the magnitudes of the speed of advance and the velocity at the jet exit. Good jet efficiencies may be obtained by jet velocities which are but slightly higher than the corresponding speeds of advance. Obviously, the exit cross sections must then be chosen large enough to produce the required thrust. As indicated in Equation [5.5], it may be anticipated that high-speed boats produce good efficiencies as a result of their high speed of advance.

The propulsive jet power of the propulsion mechanism, i.e., the sum of the thrust power and the jet loss power, is identical to its useful delivered power at the cross section of the jet exit

$$N_H = \gamma F_A v_A H_0 \quad [5.7]$$

if H_0 designates the useful delivery head referred to the cross section at the jet exit. From Equations [5.2], [5.3], and [5.7], we obtain the delivery head H_0 expressed by the velocities

$$H_0 = \frac{v_A^2 - v_P^2}{2g} \quad [5.8]$$

Since, as we have pointed out previously, the difference between the speed of advance and the jet velocity is to be as small as possible in order to obtain a good jet efficiency, it is found that within the range of low speeds of advance, propulsion mechanisms with large delivery volumes are advantageous at relatively small delivery heads, i.e., propeller pumps. In the range of high speeds of advance, rotary pumps (centrifugal pumps) are more favorable under certain circumstances since, in this case, the delivery heads become larger, too.

If such a propulsion mechanism is installed on a hull, the size, arrangement, and mode of operation of the propulsion mechanism necessitates a component of power which, generally, has the effect of increasing the drag power $N_0 = W \cdot v$; i.e., a component of power which increases the required propeller thrust. This additional required power, which is designated by N_{VK} , contains in detail the following:

1. The internal resistance of the jet nozzle in case the nozzle, because of its size and arrangement, disturbs the flow pattern about the hull.
2. The frictional and thrust deduction losses which are produced on the hull by the jet.
3. The wake effect.
4. The variation in resistance due to the alteration of the system of natural waves of the ship through the jet.
5. The reaction of the intake opening upon the exit opening (hydrodynamical short circuit).
6. The sternward component of the subpressure area in front of the intake opening in the event that the intake opening is located in a region of hull rise in the sternward direction.

The power to be produced by the propulsion mechanism is thus of the magnitude

$$N_S = N_o + N_{VK}$$

or

$$N_S = \frac{1}{\eta_A} N_o \quad [5.9]$$

with the external efficiency

$$\eta_A = \frac{N_o}{N_o + N_{VK}} \quad [5.10]$$

corresponding to the quantity $\xi_S \cdot \xi_A$ in the case of ships equipped with screw propellers.

Generally speaking, a rotary jet nozzle projecting laterally or downward from the hull deteriorates the external efficiency; see Figure 28a. Whenever good maneuvering characteristics are called for, this disadvantage will have to be accepted. A rotary nozzle, built approximately halfway into the hull (see Figure 28b), is likely to be substantially more advantageous. In the latter case, the entire jet cross section is effective in straight-ahead motion, whereas only about half the jet cross section is available for maneuvering or stopping. The most favorable solution with respect to the external efficiency is a jet exit at the transom; in this case it is probably immaterial, for propulsive jet power, whether the outlet is located above or below the water surface. In this type of construction, it is necessary to provide suitable reversing mechanisms for stopping or backing. For steering, we may use either rudders located in the jet or a nozzle which reaches across the entire width of the transom, if possible. This nozzle should be provided with built-in rudders³⁴ so that the jet can be sufficiently deflected, or even partly covered under certain circumstances; see Figure 28c.

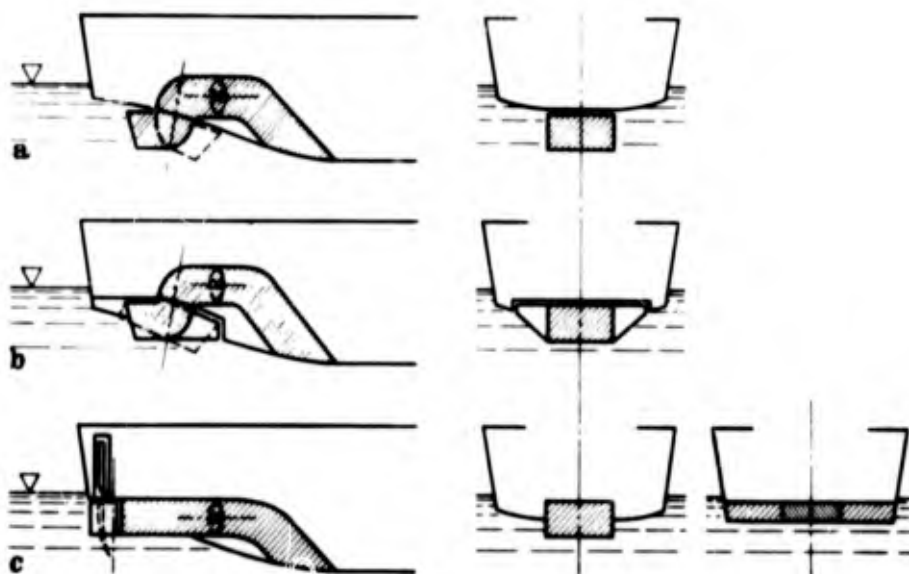

Figure 28 - Schematic Drawing of Jet-Nozzle Arrangements

The wave system produced by the jet interferes with that produced by the ship. By a suitable design of the afterbody and a suitable choice of the location of the jet nozzle, we can make sure that this interference exerts as favorable an effect as possible on the external efficiency.

A further source of losses is found in the jet-propulsion mechanism itself. There is a question of the losses which occur in the intake duct; of all the losses caused by friction, vorticity, and reversals in the housing and in the jet nozzle; of the impeller loss; and of the additional power required by a jet exit above the water surface to overcome the difference in height between the water surface and the exit cross section. The arrangement of the guide mechanisms and a water passage located inside the housing, which should be as straight as possible, is of great importance in reducing the losses in the propulsion system. The double reversal, necessary with the arrangement of rotary jet nozzles below the hull has a very unfavorable effect. If the losses in the propulsion mechanism are designated by N_{VT} then the power to be supplied to the propulsion mechanism is

$$N_{Tr} = N_{id} + N_{VT}$$

or

$$N_{Tr} = \frac{1}{\eta_{Tr}} N_{id} \quad [5.11]$$

if we denote

$$\eta_{Tr} = \frac{\rho F_A v_A (v_A^2 - v_f^2)}{2 N_{Tr}} \quad [5.12]$$

the internal efficiency of the propulsion system.

With the aid of the three individual efficiencies, (jet, external and internal) the total efficiency of the propulsion of a ship with jet propulsion can now be indicated as follows:

$$\xi_o = \frac{N_o}{N_{Tr}} = \eta_{id} \cdot \eta_A \cdot \eta_{Tr} \quad [5.13]$$

Figure 29 shows a schematic representation of the afterbody of a ship with a jet nozzle arranged below the ship's bottom. The areas where the losses just described occur are indicated by differential shading.

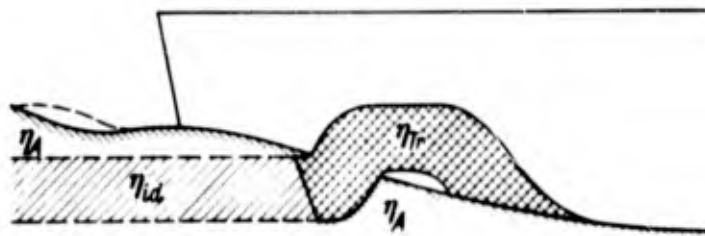

Figure 29 – Schematic Drawing of Areas Where Losses Occur

5.2 MODEL TESTS

The usefulness of a propulsion mechanism is determined by the magnitude of the overall efficiency ξ_0 obtained by it. Any determination of the efficiency in the usual manner, i.e., by model tests for which it is necessary to install, in a scaled-down ship model, a jet-propulsion mechanism reduced on the same scale, appears to be hopeless. This is true because it is hardly possible to synchronize the specific speed, which characterizes pump model tests, with similitude according to Froude, which characterizes ship model tests. As indicated previously, the overall efficiency is composed of three component efficiencies. Two of these efficiencies, i.e., the jet efficiency and the external efficiency, may be determined in the conventional manner by means of ship model tests. The internal efficiency of the propulsion system, however, can be determined for a given delivery volume and a given useful delivery head only by means of pump model tests which make allowance for the specific speed.

To determine the jet efficiency and the external efficiency, it is necessary to conduct a normal resistance test, without the appendages called for by the propulsion system and a propulsion test in which the water mass carried through—and thus the mean jet velocity in—the scaled-down jet nozzle are measured. These tests were expected to yield information regarding the most favorable arrangement of the intake and exit cross sections and to consider also the effect exerted on the wave pattern. Such tests have been carried out in the VWS (Research Institute for Hydraulic Engineering and Shipbuilding - Berlin Tank) with a model of a self-propelled inland vessel of the KARL VORTISCH type to the scale of $\alpha = 15$.³⁴ The pump was located outside the model. Figure 30 presents a schematic representation of the arrangements of the intake and exit openings investigated and Figure 31 shows, from the results of the propulsion tests, the water mass carried through which, in turn, represents a measure of the generated thrust. The schematic representation referred to indicates that an arrangement of the exit nozzle at the stern and an arrangement of the intake nozzle in the forebody or in the afterbody are the most favorable. An elbow open in the direction of motion and located at the intake opening proved to be an unfavorable arrangement with the location of the intake opening in the vicinity of the bow, it was not possible to observe any favorable effect on the bow wave formation. Long water ducts in the ship deteriorate the internal efficiency of the propulsion system. Hence, an intake opening installed on the forebody, although representing in this special case the optimum solution with respect to the required thrust as indicated by the test results, is more unfavorable, on the whole, than an arrangement of the intake opening in the vicinity of the exit opening at the stern, which requires only a slightly higher thrust.

At the present time, additional model tests are in preparation to find practical methods for reducing the stern wave system of a jet-propelled vessel. Provision is made, among other things, for the systematic variation of the form of the jet cross section on the model of a utility boat and for the measurement of the stern waves produced.

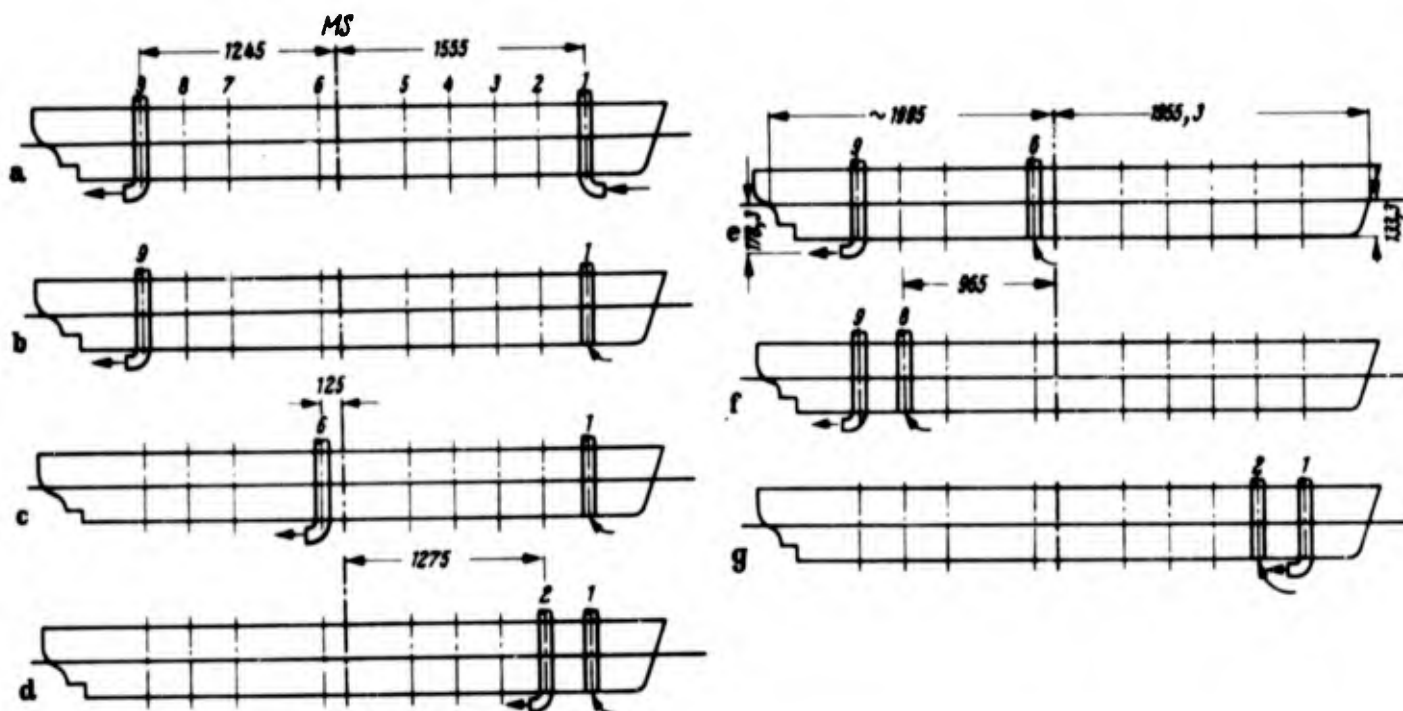

Figure 30 – Model Tests with Jet Propulsion
 Showing Variation of the Location of the
 Intake or Exit Cross Sections

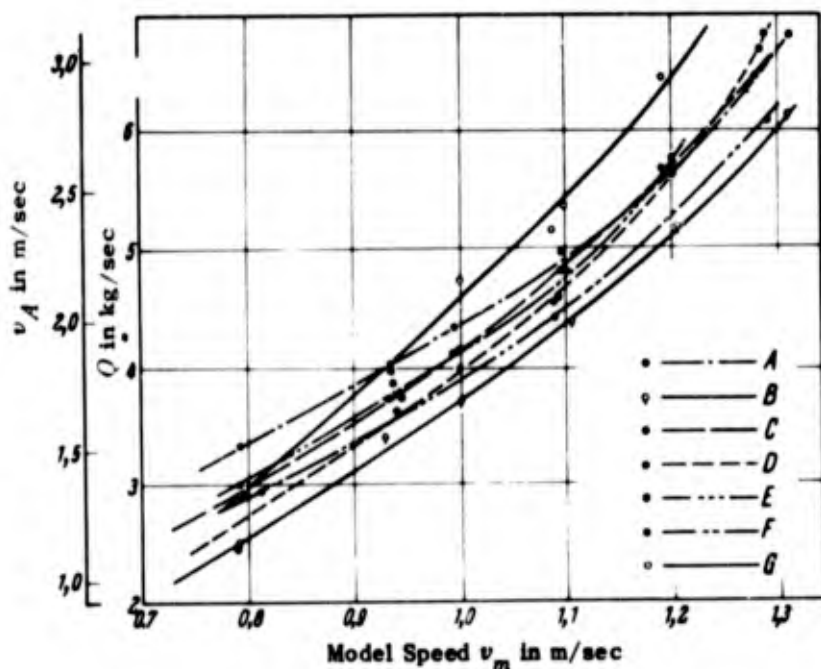

Figure 31 – Results of Model Tests with Jet Propulsion
 (See also Figure 30)

5.3 EXAMPLES OF VARIOUS DESIGNS

To conclude our analysis of continuously operating jet-propulsion systems, we shall quote a few examples of vessels actually constructed with jet-propulsion mechanisms or of vessels still in the design stage.

In 1959, the Teltow Shipyard in Berlin built a service boat 10 m long, i.e., a pure utility craft (see Figure 32), which was equipped with a KSB-Nowka propulsion mechanism. When producing an engine power of 58 hp, this boat reaches a speed of 15 km/hr in deep water. The propulsion mechanism consists of a one-stage twin axial flow pump (see Figure 6b) and a jet nozzle which is installed below the ship's bottom at the stern and is capable of rotating through a 360-deg angle. The client, the Wasser-und Schifffahrtsdirektion Münster (the Navigation and Shipping Authority at Münster), made it possible to carry out sufficiently extensive trial and test runs to measure the power and jet velocity both in free-running tests in deep water and in the canal. Also, towing tests and bollard pull tests were conducted. These tests were supplemented by resistance tests in the deep-water and shallow-water towing basin of the VWS with a model of this boat to the scale of $\alpha = 3.35$. With the aid of the test results obtained, all the data for the propulsion system of interest to us could be determined. Figure 33 shows the delivery volumes Q and the useful delivery heads H_0 of the propulsion mechanism as a function of the power supplied to the propulsion mechanism. Figure 34 gives the often-mentioned component efficiencies and the total efficiency. The efficiencies η_A and η_{Tr} are very low in this case. This is attributed largely to the arrangement of the jet nozzle. The arrangement was chosen because of the need for good maneuvering qualities in a service boat; nevertheless, it should certainly be possible to improve the efficiencies η_A and η_{Tr} and, thereby, to increase the total efficiency. The following data will serve to characterize the maneuvering qualities:

TABLE 2

Stopping time from maximum speed	6 sec
Stopping distance from maximum speed	10 m
Turning-circle diameter at full speed	10 m (approx)
Turning-circle diameter at zero speed	0 (boat turns "on a nickel")
Time (required) for a 360-deg turn at maximum engine load	15 sec
Steering qualities ahead and astern	Very Good
Course stability (directional stability)	Poor, but remarkably good in towing (no swerving)

The results of the towing tests with the 24-m model ship HEDWIG KLOESS and of the bollard pull tests are shown in Figure 35. The specific bollard pull lies above 11 kg/hp at maximum



Figure 32 – Service Boat with Jet Propulsion

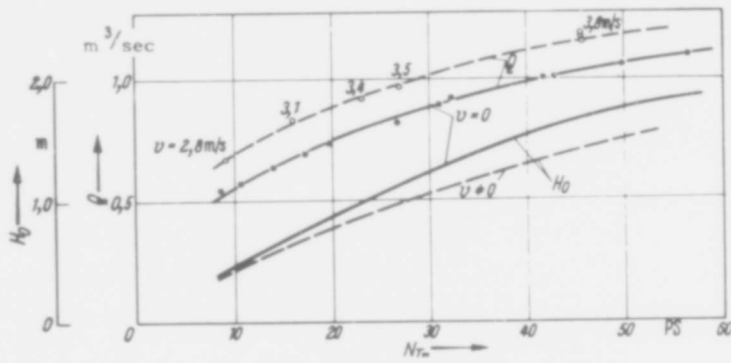

Figure 33 – Delivery Volumes and Useful Delivery Heads of a 56-Horsepower Jet-Propulsion System

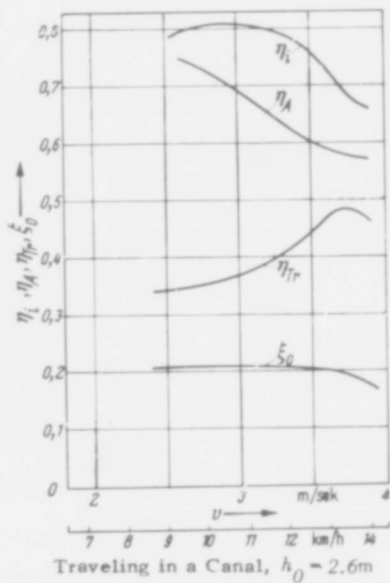

Figure 34 – Efficiencies

load; this is a greater pull than can be attained in this case with a comparable screw propeller. As the power decreases, the specific thrust increases. The characteristic curve is similar to that of a variable-pitch propeller. Propulsion systems that are specially designed for towing at low speed are likely to yield even more favorable values.

A further example of a boat with jet propulsion is a 4.4-m, high-speed sporting boat (planing boat). We are referring to the Dowty-Hamilton-Turbocraft shown in Figure 36.³⁶⁻³⁸ This boat is equipped with a two-stage axial flow pump as the propulsion mechanism (see Figure 6a), and attains a speed of approximately 56 km/hr at an engine power of about 75 hp. The exit opening of the propulsion unit is located at the transom and lies above the water surface while in motion. Guide fins arranged laterally next to the jet serve for steering purposes whereas a reversing plate, which is introduced into the jet, is used for stopping and moving astern. This boat, too, has good maneuvering qualities. It is likely, however, that the lateral plane, which is very small in the planing condition, plays a major part. The VWS was indeed able to conduct

trial runs with this type of boat, but no measurements were carried out. For this reason, to judge the propulsion unit, we drew upon the data published in the relevant literature. Because the data were unfortunately, incomplete, and partly inconsistent, we supplemented the data by calculations and cautious estimates. Hence, the component efficiencies obtained in this manner can be regarded only as reference values. Table 3 shows a comparison of the data characterizing both the boat and propulsion mechanism of the service boat, given as the first example, for a rate of speed slightly below the maximum speed (Ship A) and with the data of the Dowty boat (Ship B). It is noteworthy that all the component efficiencies of Ship B, and thus also the total efficiency, lie considerably above the values of Ship A. The superiority of the jet exit at the transom is particularly striking. It is a disadvantage that Ship B can move astern only slowly and that it is not capable of maneuvering when moving astern.

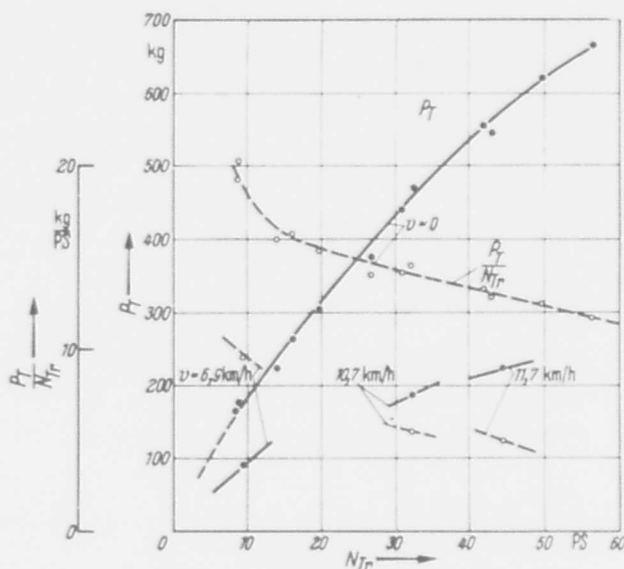

Figure 35 - Towing Tests and Bollard Pull Tests

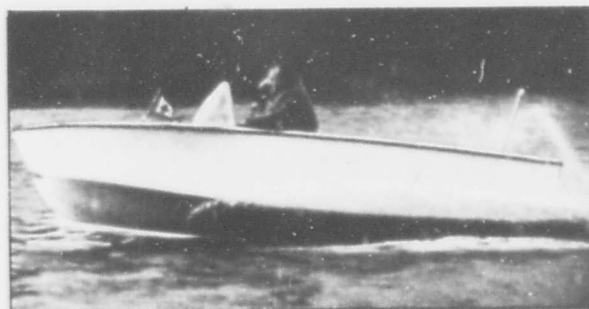

Figure 36 - Planing Boat with Jet Propulsion

TABLE 3

	Ship A	Ship B
Length, L	9.60 m	4.42 m
Breadth, B	2.44 m	1.75 m
Draft, T	0.54 m	
Weight (including crew and fuel), D	4900 kg	800 kg
Speed, v	4.06 m/s 14.6 km/h	15.6 m/s 56.3 km/h
Lift-drag ratio, W/D	0.036	0.23
Power output of propulsion unit, N_{Tr}	52 hp	75 hp
Exit cross section of nozzle, F_A	0.18 m ²	0.02 m ²
Jet velocity, v_A	6.62 m/s	20.4 m/s
Jet nozzle arrangement	Mounted on a pivot below the bottom	Fixed in the transom
Jet efficiency, η_{id}	0.69	0.87
External efficiency, η_A	0.56	≈ 1.0
Internal efficiency, η_{Tr}	0.48	0.59
Total efficiency, ξ_0	0.19	≈ 0.51

The relatively high ideal jet efficiency of Ship B confirms the line of reasoning followed in the introduction that good efficiencies are to be expected for high-speed vessels. The propulsive efficiency in excess of 50 percent indicates that at least in this particular case jet propulsion with respect to speed may be superior to screw propulsion.

Figure 37 shows the design of a 230-hp tugboat equipped with a KSB-Nowka propulsion unit (twin-axial flow pump). The shapes of the propulsion unit and of the stern are largely in harmony with one another. Pronounced curvatures in the water ducts are avoided so that better component efficiencies η_A and η_{Tr} may be expected than in the aforementioned 10-m vessel. Finally, Figure 38 shows new Russian designs of propulsion units with the jet exit below the transom.³⁸ The steering process is effected through jet deflectors. The arrangement of baffles next to the hull in the case of the twin-jet design is interesting; see Figure 38b. If the rudders are turned 90 deg, the jets are deflected forward by means of the baffles so that it becomes possible to stop or move astern.

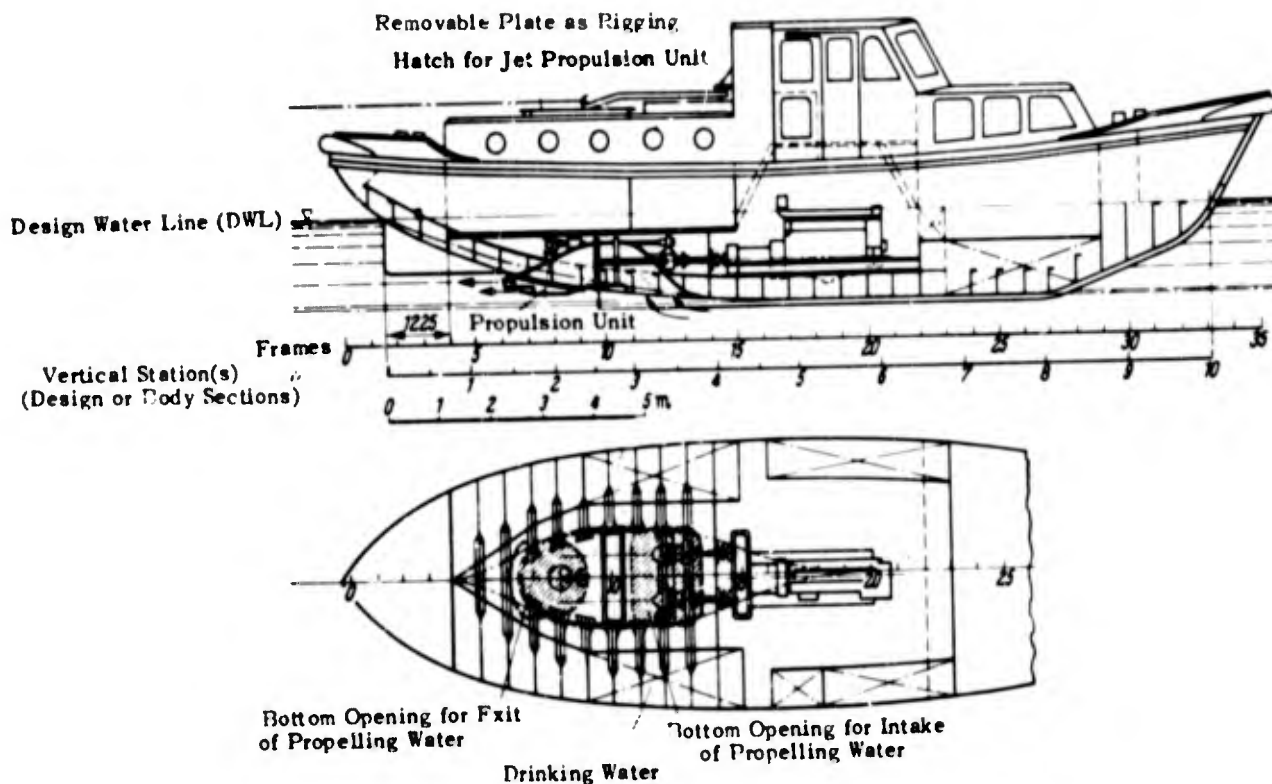

Figure 37 – 230-Horsepower Tugboat with Jet Propulsion
(in Design Stage)

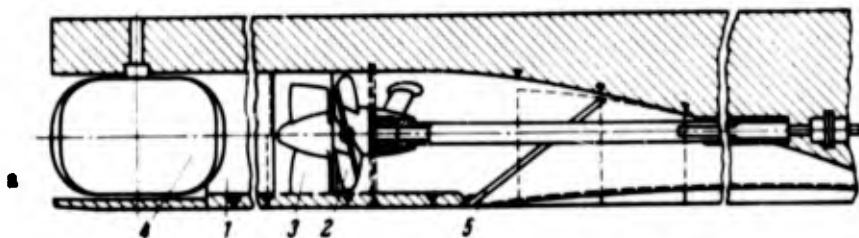

Figure 38a – Single-Jet Design

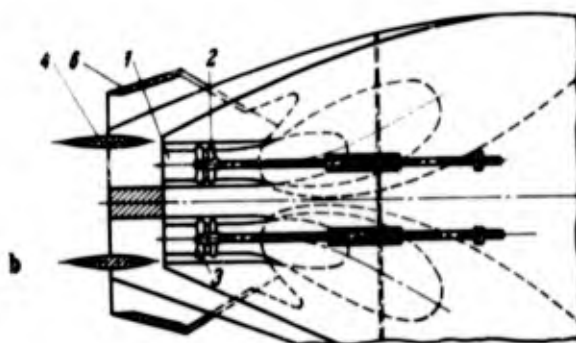

Figure 38b – Twin-Jet Design

(1 tube, 2 propeller, 3 guide vanes, 4 rudder, 5 screen,
6 reversing mechanism)

Figure 38 – Jet-Propulsion Systems for Shallow-Draft Vessels
(According to Basin and Medwedew,³⁹)

6. SUMMARY

After a resumé of the historical development and a presentation of the future prospects of the water jet-propulsion system in general were given, the various modes of operation and design forms were described. Those modes and forms most practical from an engineering standpoint were described in more detail. A detailed analysis of the hydromechanical problem of the thrust generation in the intermittently operating pulse jet propeller led to a useful method of solution. A thermodynamic mode of operation was described for the special case of a gas-water jet-propulsion system. Continuously operating jet-propulsion systems were evaluated on the basis of the results of model tests and trial trips. Film strips were used to show a slow-speed 5-ton boat and a high-speed, 1-ton boat undergoing testing.

Thereupon, we proceeded to the execution of model tests. A ship model with air cushion propulsion was tested in the shallow-water basin. The rise in the mean thrust with increasing piston speed was demonstrated for a pulse jet propeller at zero speed while the pressure and thrust distribution of an intermittently operating gas-water jet-propulsion system was measured on the towing carriage. In the deep-water basin, a propulsion test was carried out with the model of a service boat equipped with a continuously operating water jet-propulsion mechanism fitted with a wide slot-shaped exit. In the circulating-water channel, finally the vortex street produced by a pulse jet propeller was shown. The measuring instruments by which the investigations are to be continued experimentally were demonstrated.

All in all, an attempt was made to present a comprehensive picture of the various possibilities of the water jet-propulsion systems permitted by a far-reaching adaptation to the operating conditions.

REFERENCES

1. Busley, C., "Die Entwicklung der Schiffsmaschinen in den letzten Jahrzehnten," Berlin/Göttingen/Heidelberg (1890) Springer.
2. Rabbeno, G., "Allgemeine Betrachtungen über Strahlpropeller," Jahrb. STG, Vol. 31 (1930), pp. 215-228.
3. Dickmann, H.E., "Schiffsantrieb mit instationären Vortriebsorganen," Schiff und Hafen Vol. 2, No. 10 (1950), pp. 252-265.
4. Reynst, F.H., "Das Schmidt-Rohr," Allgemeine Wärmetechnik, Vol. 6 (1955).
5. Bertin, J. and Le Foll, J., "Das Pulsotriebwerk der SNECMA-Escopette," Interavia, Vol. 8 (1953), p. 347.
6. Reynst, F.H., "Pulsierende Feuerungen im Dampfkesselbau," Mitt. d. Vgg. d. Grosskesselbesitzer (1952/53), pp. 419-436.
7. Rader, H. and Schuster, S., "Coanda-Untersuchungen 1, Grundlegende Versuche mit Pilzkörper und Düse," Berichte d. Versuchsabt. d. Gobr. Sachsenberg AG (1942).

8. Rader, H., "Tätigkeitsbericht über Versuche und Arbeiten auf dem Gebiet der Strahlantriebsforschung," Bericht d. Versuchsabt. d. Gebr. Sachsenberg AG (1944).
9. Métral and Zerner, "L'Effet Coanda," Paris (1948).
10. Flügel, G., "Berechnungen von Strahlapparaten," VDI-Forschungsheft 395, Second Edition (1951).
11. Küssner, H.G., "Zusammenfassender Bericht über den instationären Auftrieb von Flügeln," Luftfahrtforschung, Vol. 13 (1936), p. 410.
12. Schwanecke, H., "Beitrag zur Theorie der instationären Tragflügelströmung," Schiffstechnik, Vol. 5 (1958).
13. Dickmann, H.E. and Weissinger, J., "Beitrag zur Theorie optimaler Düsenschauben (Kortdüsen)," Jahrb. STG, Vol. 49 (1955), pp. 253-305.
14. Föttinger, H., "Neue Grundlagen für die theoretische u. experimentelle Behandlung des Propellerproblems," Jahrb. STG, Vol. 19 (1918), pp. 385-472.
15. Hamel, G., "Mechanik der Kontinua," Stuttgart (1956).
16. Kotschin, N.J., Kibel, I.A., and Rose, N.W., "Theoretische Hydromechanik," Berlin (1954).
17. Dickmann, H.E., "Forschungsbericht über instationäre Schiffsantriebe," (not published).
18. Felsch, K.O., "Studienarbeit am Lehrstuhl u. Institut f. Strömungslehre u. Strömungsmaschinen der TH Karlsruhe," (not published).
19. Eichelberg, I., "Forschung auf d. Gebiet d. Ing.-Wesens," Vol. 300 (1928).
20. Pfriem, H., "Nichtstationäre Wärmeübertragung in Gasen, insbesondere in Kolbenmaschinen," FDI-Forschungsheft 413.
21. Pfriem, H., "Wärmeübertragung bei schnellen Druckänderungen in Gasen," Forschung auf d. Gebiet d. Ing.-Wesens, Vol. 13, No. 4.
22. Schmidt, E., "Das Differenzverfahren zur Lösung der nichtstationären Wärmeleitung, Diffusion und Impulsausbreitung," Forschung auf d. Gebiet d. Ing.-Wesens, Vol. 13, No. 5, pp. 177-185.
23. Linke, W. and Kunze, H., "Druckverlust and Wärmeübergang im Anlauf der turbulenten Rohrströmung," Allgemeine Wärmetechnik, Vol. 4, No. 4 (1953), pp. 73-79.
24. Schultz-Grunow, F., "Pulsierender Durchfluss durch Rohre," Forschung auf d. Gebiet d. Ing.-Wesens, Vol. 11 (1941), p. 170.
25. Schultz-Grunow, F., "Durchflussmessverfahren für pulsierende Strömungen," Forschung auf d. Gebiet d. Ing.-Wesens, Vol. 12 (1941), p. 117.
26. Betz, A., "Hydro- and Aerodynamik," Vol. 11 of the series "Research in Natural Science and Medicine in Germany" (1939-1946), Weinheim (1953).

27. Schultz-Grunow, F., "Nichtstationäre eindimensionale Gasbewegung," *Forschung auf d. Gebiet d. Ing.-Wesens*, Vol. 13, No. 3, pp. 125-134.
28. Knappe, G., "Betrachtungen u. Berechnungen eines intermittierenden Gas-Wasser-Antriebs (not published).
29. Knappe, G., DBP 810841.
30. Noack, W.G., "Die Humphrey-Pumpe," *VDI-Z.*, Vol. 57 (1913), pp. 885-892 and 942-948.
31. "Eine neue Bauart der Humphrey-Pumpe," *VDI-Z.*, Vol. 60 (1916), p. 741.
32. "The Trials of the Humphrey Pump at Chingford," *Engineering*, Vol. 96 (Dec 1913), pp. 835-836.
33. Holtzwarth-Gasturbinen, received from Holtzwarth-Gasturbinen GmbH. Mülheim/Ruhr.
34. Schuster, S., "Hydraulischer Reaktionsantrieb für Schiffe," *VWS-Bericht*, No. 83/57 (unpublished).
35. Schwanecke, H., "Erprobung eines 10-m-Strommeisterbootes mit KSB-Nowka-Strahlantrieb. *VWS-Bericht* No. 143/60 (unpublished).
36. Docter, H., "Das Dowty-Turbo-Düsenboot," *Hansa*, Vol. 97 (1960), p. 1552.
37. "33 mph Runabout Using Water Jet Propulsion," *Ship and Boat-BUILDER* (1959), p. 87.
38. "Wasserstrahlantrieb für Motorboote," *Das Motorboot* (1960), p. 82.
39. Basin, A.M. and Medvedev, S.P., "Raschet dvizhitel 'nogo Kompleksa vodometnogo, sudna po rezud'taton ispytanii modeli," *Rechnoi Transport*, Vol. 18, No. 11(1959), pp. 16-21.

DISCUSSION

Dr. W. Trommsdorff, Aachen.

I should like to ask questions and I should also like to make a statement. First the questions: When and by whom has the gas-water jet-propulsion system first been proposed and made public? Might it be possible that the first reports on this subject were published during the war and that these came from the team working with Prof. Ackermann, then carrying on research at Danzig and presently at Munich?

These are my questions and now for my statement. The evaluation of the gas-water jet-propulsion system, of its efficiency, and of its thrust density, requires the mathematical establishment of a family of characteristic curves. For the design of a gas-water jet-propulsion system, the following independently varied parameters are of importance and must be introduced into the calculation: First, the degree of air admixture defined by the ratio of the mass of air, which passes through the body of the propulsion system per unit of time; to the mass of water passing through the body of the propulsion unit; second, the degree of deceleration in the diffuser defined by the ratio of the lowest water velocity in the diffuser divided by the approach flow velocity of the water; third, the depth of the water in which the propulsion unit operates; fourth, the operating speed of the propulsion unit. If we carry out the calculation of the families of characteristic curves, we obtain the following result: At a high degree of air admixture, we obtain a high thrust density, a small light propulsion unit, but a poor efficiency. If the degree of air admixture is reduced, the efficiency of the propulsion unit is increased; at the same time, however, the thrust density drops and the propulsion units become larger and larger. If the degree of air admixture is reduced further, the efficiency decreases again for the reason that the increasing surface of the propulsion unit brings about an ever-increasing frictional resistance which must be deducted from the thrust produced. If the surface friction on the outer skin and inside the body of the propulsion unit is taken into consideration, a limit is reached beyond which the unit cannot be increased without reducing the efficiency again. The influence of the degree of deceleration in the diffuser has a similar effect. A small degree of deceleration should produce a good internal efficiency of the transformation of energy of the compressed air introduced. A small degree of deceleration, however, can only be attained by means of a large unit with a large surface and with correspondingly great surface friction. For this reason, the degree of deceleration of the diffuser also can only be reduced to a certain value. Greater water depths decrease the efficiency, up to a small water depth the resistance of the unit is increased by an additional wave resistance.

At greater speeds, I attain better efficiencies and better thrust densities; it is necessary, however, to produce higher compression in the compressor. If the water pressure jet-propulsion mechanism itself is designed as the lifting device of a hydrofoil craft and if, accordingly, only the friction of the internal flow is taken into consideration in analyzing the efficiency, we obtain for high-speed craft at about 40 knots, efficiencies of 60 percent and at 50 knots, we should obtain efficiencies of nearly 70 percent.

If the gas-water jet-propulsion mechanism is designed properly, it is probably the only means for the time being to propel the hydrofoil craft, since at these above-mentioned speeds the cavitation phenomena on the hydraulic screw reduce the latter's efficiency below that of the gas-water jet-propulsion system.

I should like to conclude this statement by pointing out that the Deutsche Versuchsanstalt für Luftfahrt (German Research Institute for Aviation) is presently carrying on systematic investigations on the gas-water jet-propulsion system.

Dipl.-Ing. R. Dervedde.

I believe that the gas-water jet-propulsion system is first mentioned in a French patent by Bidard and Chalom in the year 1948.

Prof. S. Schuster.

We wish to thank Dr. Trommsdorff very much for his suggestions from the DVL (Deutsche Versuchsanstalt für Luftfahrt). The efficiencies, however, appear to us to be very high and we do not believe that we shall be able to obtain such values in the course of our tests. Nor are we thus far convinced that the gas-water jet-propulsion system constitutes as yet, a debatable mode of propulsion for hydrofoil boats. Moreover, we are unable, in particular, to concur in your opinion regarding the fully cavitating propeller. As a matter of fact, a fully cavitating propeller need not be worse than a noncavitating one by any means. Developments providing for fully cavitating hydrofoils and propellers are in progress right now for the express purpose of being able to utilize the recently announced advantages deriving from full cavitation. Also, we would sound a note of warning lest the possibilities of the jet-propulsion system be overestimated. We are altogether skeptical and we believe that we can only say that here and there jet propulsion may equal the screw propeller and may perhaps surpass it where the external conditions such as shallow water, constructional limitations, etc., would only permit the use of poor screw propellers.

Dipl.-Ing. H. J. Schwöchheimer.

The investigations carried out so far have indicated that the thrust tube here described appears to be suited precisely to hydrofoil boats. According to these investigations, we may expect a better total efficiency with the thrust tube than with the gas-water jet-propulsion system.

Dr. Eng. F. Gutsche, Berlin.

Gentlemen: Permit me, please, to make a few short remarks regarding the reports which we have just heard. Supplementing the statements made by Prof. Schuster regarding the flapping-wing propulsion, I should like to give a clue to the practical design of such a propulsion mechanism for a rowboat.

Some 22 years ago when I was still connected with this Institute, Mr. Budig demonstrated a small folding boat which was equipped with a pair of flapping wings. The flapping-wing unit was operated by means of a pedal-operated generator which imparted to the boat a top speed of about 9 km per hour.

My second remark concerns the use of radial flow pumps for the jet propulsion of ships whose suitability was twice suggested in the foregoing reports as a practically useful solution.

On account of the multiplicity of reversals and changes in the flow cross section which exist in the case of a radial flow pump, it seems to me that its use is hardly suitable for ship propulsion. This seems to be true, especially, since for ship propulsion we must always strive for a slight acceleration of the greatest possible water mass, whereas the radial flow pump, after all, is primarily designed for a limited water passage with a considerable increase in pressure.

Hence, if we are to set up a propulsion system in relation to the usual screw propulsion system with a rudder behind, I advise only the use of an axial flow pump with the greatest possible flow cross section and with the fewest possible reversals. Such a system, while improving its steering qualities, does not exhibit too great a loss of efficiency compared to screw propulsion, as indicated perhaps in the propulsion systems described in the foregoing reports.

With a view to these features, I recently proposed a propulsion system whose design, which follows the lines of the bow jet rudder of the design with vertical drive shaft of the pump impeller as proposed by me, leads us to expect total efficiencies of the propulsion that compare favorably with the screw propulsion systems.

Dr. Eng. P. Schreiber, Hamburg.

Fundamentally speaking, the statements of Mr. Schwechheimer remind me of the investigations which were carried out some 40 years ago at the Institute for Flow Research in Danzig by Prof. H. Föttinger although the latter pursued different objectives. The problem he faced was that of obviating the difficulties due to insufficient resistance to heat of the available steels (difficulties that existed in the gas turbine area then and partly even now) by delivering the combustion gases, rich in energy, not to a gas turbine with a corresponding blading directly, but by utilizing them in a suitably designed hydroturbine in the round-about way via the medium water. This is to say that the energy of the combustion gases should be transmitted to the water and should accelerate the latter. Even the preliminary tests with compressed air indicated that a large portion of the compression energy of the gas served merely to stir up the water surface into uncontrollable agitation (froth production) and was thereby lost for the acceleration of the water. In order to calm the effective water column—which may be compared to a water piston—centrifugal forces were transmitted to the free water surface (bottom of the piston) by means of a special test setup and the latter was then exposed to the gas flow. Even this method did not lead to any completely satisfactory solution at that time, so that the project was set aside for the time being.

In subsequent years, though in a different connection, I had the opportunity once again of taking part in experiments in which thrust measurements were carried out on underwater bodies with jet propulsion, i.e., experiments in which hot combustion gas (about 35 atmospheres absolute pressure), as well as compressed air, was being used. The test results were hardly satisfactory. The computed efficiencies were actually never reached because a large portion of the compression energy was used up for the purpose of "froth production" in the water and because, in the case of hot combustion gases, cooling and condensation contributed to the poor effect. Jet propulsion thus far has been unable to replace the hitherto existing screw propulsion.

The questions which come up in this connection and which I should like to submit to Mr. Schwechheimer for reply are the following:

1. What is the effect of the gas bubbles or of the gas stream on the effective water cross section?
2. What is the effect of the cooling and condensation losses of the hot combustion gases on the jet propulsion?
3. Has it been possible in the meantime to overcome these difficulties and what kind of efficiencies may possibly be reached with this test setup and what is the comparative efficiency of the jet propulsion in water compared to the conventional screw propulsion if the source of energy is the same?

Another question of interest would possibly be that concerning the effect of the jet propulsion on the vibrations of the ship.

Dipl.-Ing. H. J. Schwechheimer.

Tests carried out by Dickmann and preliminary tests carried out by the author resulted in a closed partition wall between the working gas and the water insofar as the water passage was not disturbed by mounting fixtures or sharp-edged deflecting devices. It seems to be essential in this connection that when using combustion gases, the combustion takes place in a combustion chamber separated from the water since the processes which occur in the gas cause the partition wall to be ruptured in the course of the combustion. Moreover, the combustion becomes incomplete on account of an excessive cooling of the mixture or a condensation of the fuel, resulting in a heavy pollution of the installation. In most of the tests reported thus far—in the case of the Humphrey pump, for instance—the water swings back and is then accelerated from standstill in a direction opposite to that of its original motion, while in the setup described here, the water plug already possesses a considerable velocity, before being accelerated further in the same direction by the working gas. It should be borne in mind, moreover, that the working gas does not exert an effect on the water as a sharp jet, but displaces the latter like a piston. Under these conditions, there appears to be no fundamental cause for a rupture of the partition wall.

The surface of the gas bubble is supposed to be as small as possible in order to keep the heat losses down. The lost heat given off to the water by the working gas is to be charged only partly against the useful work; the rest causes a reduction of the exhaust gas temperature.

Rough calculations for high-speed boats yield total efficiencies which may indeed compete with present-day units.

As for the vibration problem, I should like to say that we strive for a high frequency of the individual thrust tubes and that the attempt is made to attain an equalization of the thrust through phase displacements of the working processes of the individual thrust tubes.

Prof. W. H. Isay, Dr. Eng., Berlin.

I should like to supplement briefly the remarks of Prof. Schuster regarding fully cavitating wings. On the basis of a simple theoretical line of reasoning, one can easily make clear to himself that a fully cavitating wing has a greater lift than a wing without a cavitation bubble. It may be imagined, as a matter of fact (in accordance with the theory of the thick profiles), that a cavitation bubble extending over the entire wing chord is replaced by a source-sink distribution of total intensity zero. For the boundary condition on the wing profile from which the lift is determined, the induced velocity at the three-quarter point, $x = 0.5 a$, is sufficient at least approximately so. At this point (see following figure), however, an upward velocity is induced by the source-sink distribution replacing the cavitation bubble which brings about an increase in lift.

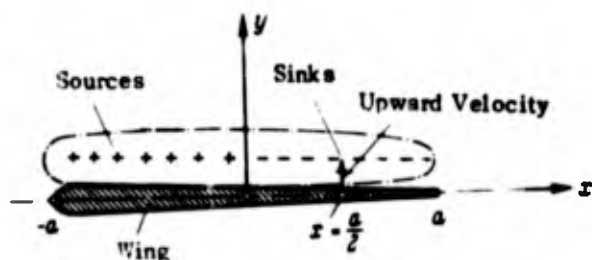

Referring to the paper on flapping wings presented by Mr. Dervede, I should like to supplement somewhat the literary references given: As early as 1939, as a matter of fact, Professor Schmeidler published a great investigation in the *Zeitschrift für angewandte Mathematik und Mechanik* (Journal of Applied Mathematics and Mechanics) in which the problem of the relationship between the forward thrust of a flapping wing and the resistance induced by its free vortices was dealt with even in three-dimensional theory.

Prof. Schuster (closing remarks).

Ladies and Gentlemen:

We shall now proceed to supplement the reports presented by experiments. The explanations relating to the various model tests will be offered to you at the individual testing stations. However both with respect to the device used and in regard to the personnel involved, one further important announcement needs to be made. I am happy to be able to advise you

that Mr. Nowka whose name has been mentioned repeatedly as a pioneer of the concept of water jet propulsion is here in our midst. I believe, Mr. Nowka, that the great number of participants as well as the interesting discussion just heard indicates more than anything else how serious an interest all of us are taking in your brain child.

That we ourselves have been able to concern ourselves intensively with the problems under discussion, we owe to the support given us by the Deutsche Forschungsgemeinschaft (German Research Association) and the Federal Ministry of Transport. I wish to thank all of you, ladies and gentlemen, for having participated in the strenuous program of the STG to the very end. I am fully aware of the fact that the abundance of the material and the rather difficult lines of reasoning presented have placed great demands upon your interest and attention. However, it would probably be inadequate to discuss such problems without presenting sufficiently detailed data on the subject.

Prof. R. Wille, Dr. Eng., Berlin (Word of appreciation).

May I take this opportunity to express our keen appreciation once again to Prof. Schuster and his team as well as to all those who participated in the discussion. I shall now ask Prof. Schuster to take charge of the proceedings and to take us on a guided tour through his laboratory. (Vivid applause).