

AD630122

Final Report

November 1965

**PENETRATION STUDIES OF ICE WITH APPLICATION
TO ARCTIC AND SUBARCTIC WARFARE**

Prepared for:

SUBMARINE ARCTIC WARFARE AND SCIENTIFIC PROGRAM
NAVAL ORDNANCE LABORATORY
WHITE OAK, MARYLAND

CONTRACT Nonr-2332(00)

STANFORD RESEARCH INSTITUTE

MENLO PARK, CALIFORNIA

***SRI**

0.57

STANFORD RESEARCH INSTITUTE

MENLO PARK, CALIFORNIA



NAVAL WARFARE RESEARCH CENTER

Final Report

November 1965

PENETRATION STUDIES OF ICE WITH APPLICATION TO ARCTIC AND SUBARCTIC WARFARE

Prepared for:

SUBMARINE ARCTIC WARFARE AND SCIENTIFIC PROGRAM
NAVAL ORDNANCE LABORATORY
WHITE OAK, MARYLAND

CONTRACT Nonr-233210C,

By: BERNARD ROSS

SRI Project ETU-2167-613

Copy No. 1

FOREWORD

The present investigation was sponsored by the U. S. Naval Ordnance Laboratory, White Oak, Silver Spring, Maryland under ONR Contract, Nonr 2332(00); SRI Project No. 2167-613. The research was conducted during the period 17 May 1965 and 1 November 1965.

The contract was monitored by M. M. Kleinerman, NOL. Project supervisor was Dr. E. G. Chilton and project leader was Dr. Bernard Ross. Contributions at Stanford Research Institute were made by Mr. P. Neketin and Mr. G. Wagner. The laboratory notebook for the experimental work was numbered 7829.

ABSTRACT

Impact tests were made on floating ice slabs with particular attention devoted to the mechanism of penetration. The range of values investigated for the basic parameters was: impact velocity, 8 ft/sec - 21 ft/sec; projectile mass, 4.56 lb - 5.22 lb and penetrator diameter, 5/16 in. - 1-1/4 in. The perforation of ice slabs made from seawater, and at approximately +17°F (warm sea ice) is accompanied by the ejection of a shear plug from the test slab, whereas fresh water ice slabs under similar loading conditions fracture into segments along well defined radial cleavage planes. The experiments indicate that a blunt end penetrator profile is significantly more effective in the perforation of warm sea ice than a corresponding penetrator with conical profile. In addition, the order of magnitude of the impact velocity and temperature of the ice slab are important factors that can govern the mechanism of penetration. A simple mathematical model for shear plug ejection, based upon the laws of conservation of linear momentum and mechanical energy, provides correlation between a potential energy quantity containing projectile mass and release height, and a geometric quantity containing penetrator diameter and sea ice thickness. Using these quantities, curves are presented which indicate a threshold-of-perforation boundary for the warm sea ice. Finally, recommendations are made for guiding future investigations in this problem area.

CONTENTS

Symbols	vii
INTRODUCTION	1
SUMMARY AND CONCLUSIONS	3
TEST SPECIMENS AND EQUIPMENT	5
TEST PROCEDURE	13
TEST RESULTS	15
EXPERIMENTAL OBSERVATIONS	
Fresh Water Ice Test Slabs	23
Sea Ice Test Slabs	24
Machine-Tested Sea Ice Slabs	27
MATHEMATICAL MODEL AND ANALYSIS	29
DISCUSSION OF TEST DATA	33
RECOMMENDED FUTURE INVESTIGATIONS	37
References	41

TABLES

Table 1	Slab Dimensions and Test Results	6
Table 2	Penetrator Shapes and Sizes	11
Table 3	Testing Machine Results	16

ILLUSTRATIONS

Figures

1	Possible Mechanisms for Ice Slab Perforation	4
2	Typical Test Specimen: Warm Sea Ice (+17°F)	5
3	Double-Walled Pan and Hot Air Blower	8
4	Test Facility	10
5	Projectile Mass and Various Penetrators	12
6	Plot of Test Results Obtained with Conical Penetrator: Warm Sea Ice (+17°F)	17
7	Plot of Test Results Obtained with Blunt End Penetrator: Warm Sea Ice (+17°F)	18
8	Plot of Test Results Obtained with Conical, Hemispherical, Concave and Blunt End Penetrators: Warm Sea Ice (+17°F)	19
9	Plot of Test Results Obtained with Conical and Blunt End Penetrators: Warm Sea Ice (-17°F)	20
10	Typical Temperature Profiles: Warm Sea Ice (+17°F)	21
11	Views of Test Slab After Impact with 1-1/4 in. Diameter Conical Penetrator: Fresh Water Ice	23
12	View of Cross-Section After Impact with 1-1/4 in. Diameter Conical Penetrator: Warm Sea Ice (+17°F)	25
13	Sketch of Mathematical Model for Shear Plug Type of Penetration	30

SYMBOLS

c	location of projectile center of gravity, see Table 2
D	diameter of penetrator
g	acceleration due to gravity
h	height above ice slab at which the projectile mass is released
m_1	mass of the projectile and penetrator
m_2	mass of the ejected shear plug
t	thickness of ice slab
v_1	velocity of projectile immediately prior to impact
v_2	velocity of projectile and shear plug immediately after impact
x, y	coordinate directions, see Figure 13
η	running coordinate, see Figure 13
$\tau_{xy}(\eta, \dot{\eta})$	shear yield stress function
τ_{xy0}	constant value of shear yield stress acting on plug during ejection, see Figure 13

INTRODUCTION

Although the Far North has witnessed vigorous scientific exploration for almost a century, it is within the last two decades that the strategic significance of this area has attracted attention. The first decade of this period was characterized by the installation of extensive warning and defense systems, an activity incited by the accompanying development of intercontinental missiles and nuclear arsenals. With the advent of long range transits and tactical under-ice operations by nuclear powered submarines, the second decade has focused attention on the tactical importance of the Far North from a military viewpoint (References 1,2,3).* It is these considerations together with the arctic's geographic situation that has influenced the Free World's increased commitment to generic problems of the Far North.

In particular, the possibility of arctic submarine warfare has called for the development of effective countermeasures. Thus, high resolution, integrated electronic systems have been considered not only for tracking and localizing alien submarines under the arctic ice, but also for determining accurately the thickness of this protective cover. In this context, the problem treated here is particularly important.

This problem can be posed simply. Given: A projectile of specified shape, dimensions and weight which is released with known initial velocity from a particular height. Required: A measure of probability that the projectile will perforate** (completely penetrate) the ice cover and, therefore, be able to continue its mission underwater.

Although abundant literature exists concerning research in ice and snow physics as well as engineering problems posed by the arctic environ-

* Numbers in parentheses refer to references collected at the end of this report.

**For the purpose of this report, penetration can be defined as the entrance of a missile into a target without completing its passage through the body whereas perforation implies the complete piercing of the target by the projectile. (See Reference 4.)

ment (References 5,6,7), and even though the penetration of frozen ground by piles and projectiles has been investigated in the past (References 8,9), it appears to this investigator that little or no previous attention has been given to the mechanics of ice penetration.* Therefore, the present study was undertaken as the initial phase of an experimental and analytical program designed to provide assistance in this general problem area to the Naval Ordnance Laboratory, White Oak, Maryland.

It should be emphasized that the basic aim of this investigation was to acquire initial experience and understanding of the penetration and fracture behavior of ice subjected to impact loading. The development of experimental techniques and the establishment of realistic future objectives were of major importance.

* In particular, the penetration of floating ice slabs.

SUMMARY AND CONCLUSIONS

An experimental program was conducted in which circular ice slabs floating in a tank of seawater were subjected to the impact of a freely falling projectile. Fresh water ice, seawater ice* at +17°F and seawater ice at -13°F were employed for the test slabs.

A projectile weighing approximately 5 lb was fitted with cylindrical penetrators of different diameters (5/16 in., 1/2 in. and 1-1/4 in., and different end profiles (conical, hemispherical, concave and blunt and allowed to impact the test slab at velocities of 8 ft/sec to 21 ft/sec

On the basis of tests performed over a relatively small range of variables, the following results were realized:

The mechanism of perforation** depended on whether fresh water ice or sea ice was being investigated. The fresh ice test slabs fractured into large segments along radial cleavage planes whereas sea ice test slabs at +17°F were perforated by the formation of a shear plug.

The mechanism of perforation depended on the characteristic temperature of the ice. For example, it was not possible to perforate the subzero (-13°F) sea ice test slab with the available penetrator mass and drop height. However, the same penetrator mass, under similar test conditions, readily produced perforation in the warm sea ice (+17°F) test slabs.

Numerical data obtained from a relatively large number of tests on sea ice at +17°F indicated that shear plug ejection was present in every instance of perforation. The following observations were applicable for this type of behavior.

* The words seawater ice and sea ice are used interchangeably throughout this report.

**Some of the possible perforation mechanisms are displayed in Figure 1 (this illustration was obtained from Reference 4).

The conical penetrator was relatively ineffective in perforating the test slab; however, the blunt end penetrator performed satisfactorily. Performances of both the hemispherical and concave penetrators were intermediate to the conical-blunt extremes.

For a given penetrator and ice slab, a minimum or threshold value of available kinetic energy at impact was required to produce perforation. This energy appeared to be related to the shear yield stress of the ice, the square of the thickness of the test slab and the diameter of the penetrator.

Tests were also conducted in which the projectile was made to impact a sea ice test slab at approximately 30° incline to the vertical direction. Qualitative results were similar to those obtained at normal incidence. That is, perforation resulted from the ejection of a shear plug; and in this process, the blunt end penetrator was significantly more effective than the conical penetrator.

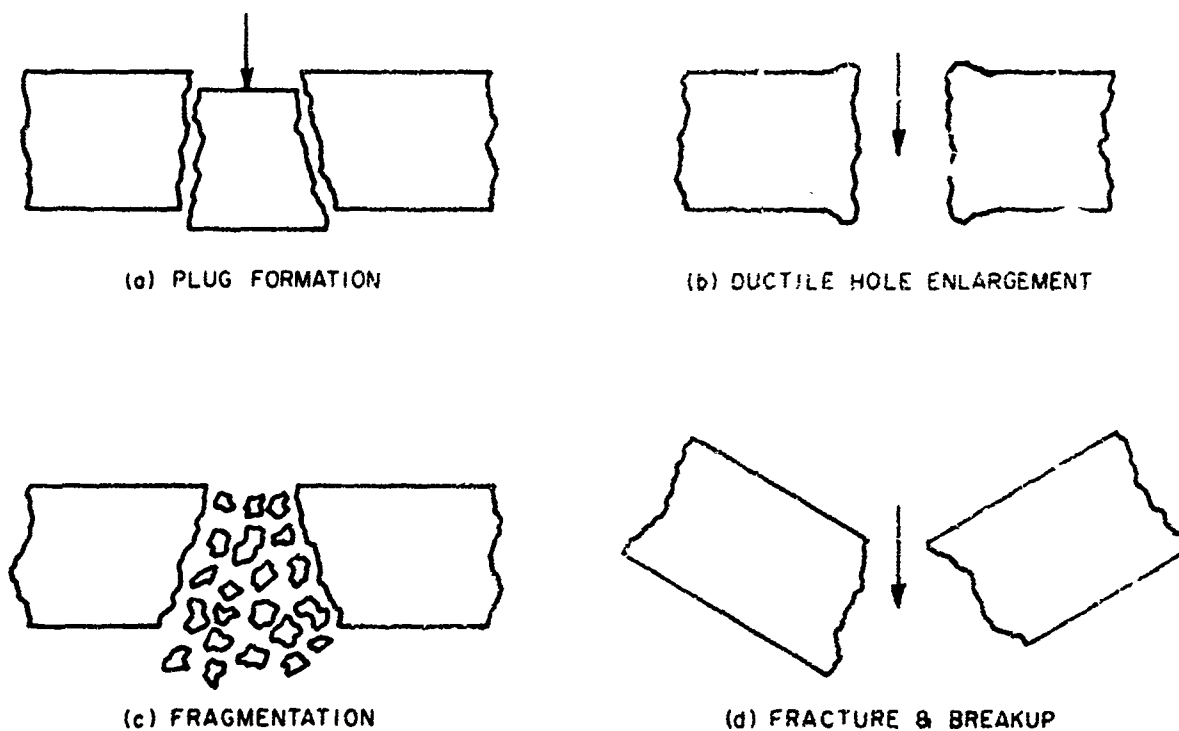

TA 201 62

FIG. 1 POSSIBLE MECHANISMS FOR ICE SLAB PERFORATION

TEST SPECIMENS AND EQUIPMENT

A series of sea ice test specimens manufactured from Pacific Ocean water was employed in the investigation. In addition, a limited number of tests were performed on fresh water ice.

All test specimens were circular slabs having a diameter of 28 in. and a thickness at the start of the experiment of 3-1/2 to 4 in. A representative example of the test slabs is shown in Figure 2; the dimensions of the test slabs are summarized in Table 1.

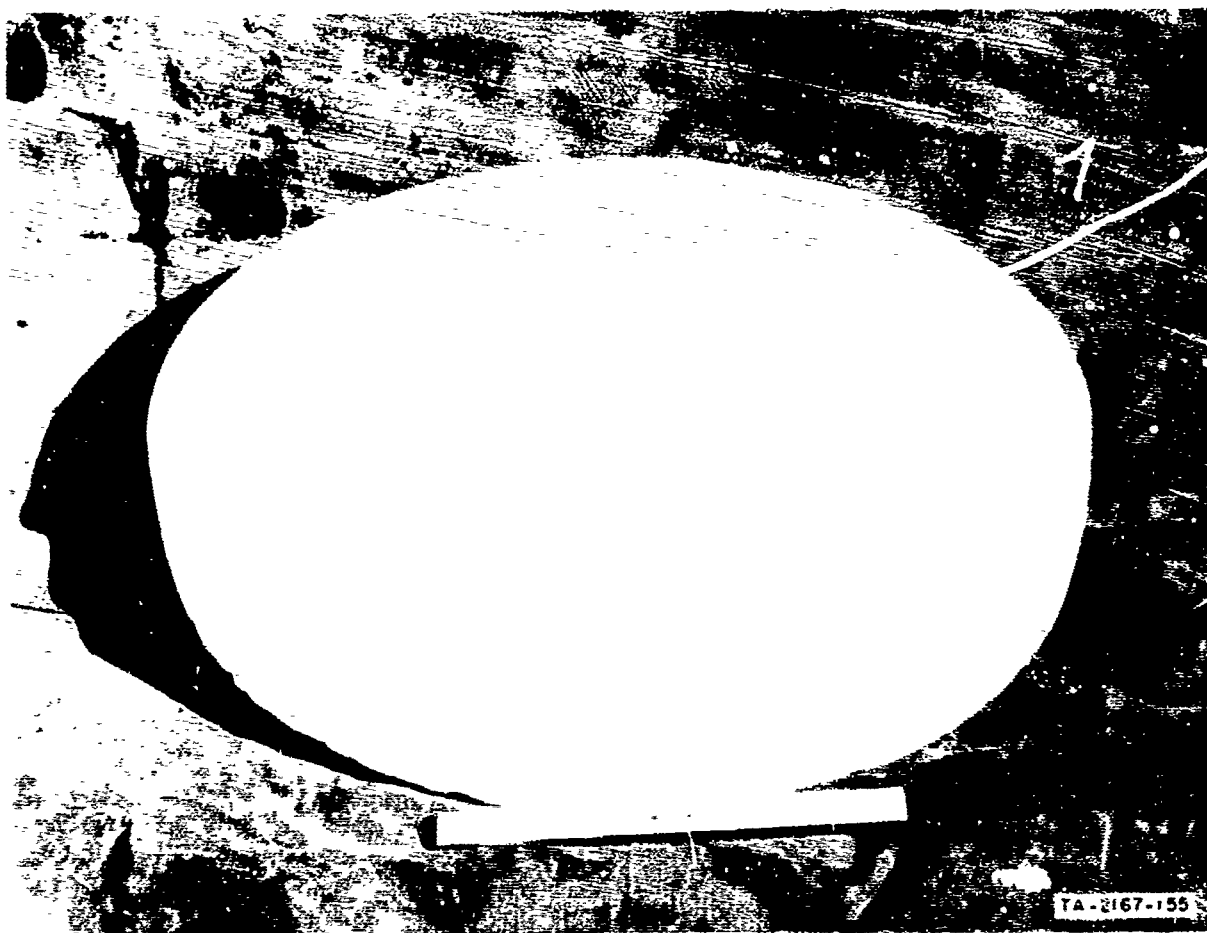

FIG. 2 TYPICAL TEST SPECIMEN: WARM SEA ICE (+17°F)

Table 1
SLAB DIMENSIONS AND TEST RESULTS

TEST SLAB	IMPACT NO.	t (in.)	PENETRATOR PROFILE	D	h	$\frac{\pi D t^2}{2}$	$\pi g h$	PERFORATION	REMARKS
				(in.)	(in.)	(in. ³)	(ft. lb.)		
I	1	4 1/2	Conical	1 1/4	74	39.8	31.6	No	Crater 1" deep
	2	4	Blunt	1 1/4	74	31.3	32.1	No	Crater 1 1/4" deep
	3	3 1/2	Blunt	1 1/4	74	24.1	32.1	Yes	
	4	3 1/4	Conical	1 1/4	74	20.8	31.6	No	Crater 1 1/2" deep
	5	3 1/8	Hemispherical	1 1/4	74	21.1	31.8	No	Crater 1 2" deep
	6	3	Concave	1 1/4	74	17.7	32.0	Yes	
	7	2 3/4	Conical	1 1/4	74	14.85	31.6	No	Slight fracture
II	1	4	Blunt	1 1/4	77	31.3	32.5	Yes	Well defined shear plug
	2	3 1/2	Conical	1 1/4	75	24.1	32.1	No	Crater 1" deep
	3	3 1/4	Blunt	1 1/4	65	20.75	27.4	Yes	Threshold of perforation
	4	3	Conical	1 1/4	63	17.7	27.1	No	
	5	2 3/4	Conical	1 1/4	63	14.9	27.1	No	
	6	2 1/2	Conical	1 1/4	53	12.25	21.9	No	Slight crater
III	1	3	Blunt	1/2	62	7.84	23.9	Yes	
	2	2 1/2	Blunt	5/16	62	3.07	23.5	Yes	
	3	2 1/8	Conical	1/2	44	3.54	16.55	Yes	
	4	2	Conical	1/2	26	3.14	9.98	No	
IV	1	4	Blunt	5/16	47	7.86	17.8	Yes	
	2	3 3/4	Blunt	5/16	41	6.80	15.55	Yes	
	3	3 1/2	Blunt	5/16	35	6.02	13.25	No	1" Penetration
	4	3 3/8	Blunt	5/16	29	5.59	11.0	No	1/2" Penetration
	5	3 1/4	Blunt	1/2	47	8.32	18.05	Yes	
	6	3 1/8	Blunt	1/2	41	7.67	15.75	No	
	7	3 1/16	Blunt	1/2	35	7.40	13.45	Yes	
	8	3	Blunt	1/2	41	7.09	15.75	Yes	
	9	2 7/8	Blunt	1/2	29	6.50	11.15	No	
	10	2 3/4	Blunt	1/2	23	5.96	8.3	No	
	11	2 1/2	Conical	1 1/4	47	12.25	19.05	No	
	12	2 1/4	Conical	1 1/4	35	9.94	14.75	No	

Table I Continued

TEST SLAB	IMPACT NO.	t	PENETRATOR PROFILE	D	h	$\frac{\pi D^2}{2}$	$\frac{1}{2} \rho g h$	PERFORATION	REMARKS
		(in.)		(in.)	(in.)	(ft. lb)			
V	1	3 1/2	Blunt	1 1/4	81	24.05	35.2	Yes	Tank water at 29 F
	2	3 1/2	Conical	1 1/4	81	24.05	31.8	No	
	3	3 1/2	Blunt	1 1/4	69	24.05	30.0	Yes	
	4	3 1/4	Blunt	1 1/4	57	20.8	21.8	No	
	5	3 1/4	Blunt	1 1/4	63	20.8	27.1	No	
	6	3 1/4	Blunt	1 1/4	51	20.8	22.2	No	
	7	3 1/4	Conical	1/2	51	8.32	19.6	Yes	
	8	3 1/2	Conical	1/2	39	9.62	15.1	No	
	9	3 1/2	Blunt	1/2	39	9.62	15.1	No	
	10	3 1/2	Blunt	1/2	51	9.62	19.7	Yes	
	11	3 1/4	Blunt	1/2	45	8.32	17.4	No	
	12	3 1/4	Blunt	1/2	57	8.32	22.0	Yes	
	13	3 1/4	Blunt	1/2	33	8.32	12.8	No	
	14	3 1/4	Blunt	5/16	45	5.17	17.2	Yes	
	15	3 1/4	Blunt	5/16	45	5.17	17.2	Yes	
	16	3 1/4	Blunt	5/16	39	5.17	14.95	No	
	17	3 1/4	Blunt	5/16	51	5.17	19.45	Yes	
	18	3	Blunt	5/16	51	4.41	19.45	Yes	
VI*	1	3 3/4	Blunt	1 1/4	80	27.6	34.7	No	Formation of crater
	2	3 1/2	Blunt	1 1/4	80	24.0	34.7	No	Enlarged crater
	3	3 1/4	Conical	1 1/4	80	20.75	34.2	No	Formation of trough
	4	3	Blunt	1/2	80	7.07	30.8	No	
	5	2 3/4	Conical	1/2	80	5.95	30.7	Yes	
	6	2 1/2	Blunt	1/2	80	4.90	30.9	Yes	
	7	2 1/4	Blunt	1 1/4	80	9.95	34.7	Yes	
	8	2	Conical	1 1/4	80	7.85	34.2	No	Formation of trough
	9	1 15/16	Conical	1 1/4	80	7.38	34.2	No	Formation of trough
	10	1 7/8	Blunt	1 1/4	80	6.91	34.7	Yes	Clean perforation
	11	1 3/4	Blunt	1 1/4	62	6.02	27.8	Yes	

* Test Slabs No. VI subjected to inclined impact (30° to vertical).

All of the numerical data were acquired for sea ice slabs at approximately $17^{\circ}\text{F} \pm 1^{\circ}\text{F}$ (warm sea ice). However, a few tests that provided only qualitative data were carried out on a subzero sea ice slab having a thickness of $4\text{-}3/4$ in. and an average slab temperature of -13°F .

A typical test specimen was manufactured over a 72-hour period by freezing seawater or fresh water contained in a stainless steel, circular double-walled pan (see Figure 3) which was placed in a cold storage freezer locker that operated at -4°F . The double wall design feature was incorporated to ensure the formation of an ice slab which would freeze uniformly from the top surface down. During the entire freezing process, heated air was recirculated through the pan by means of a blower. Periodic measurements of the slab thickness confirmed that this procedure produced satisfactory results.

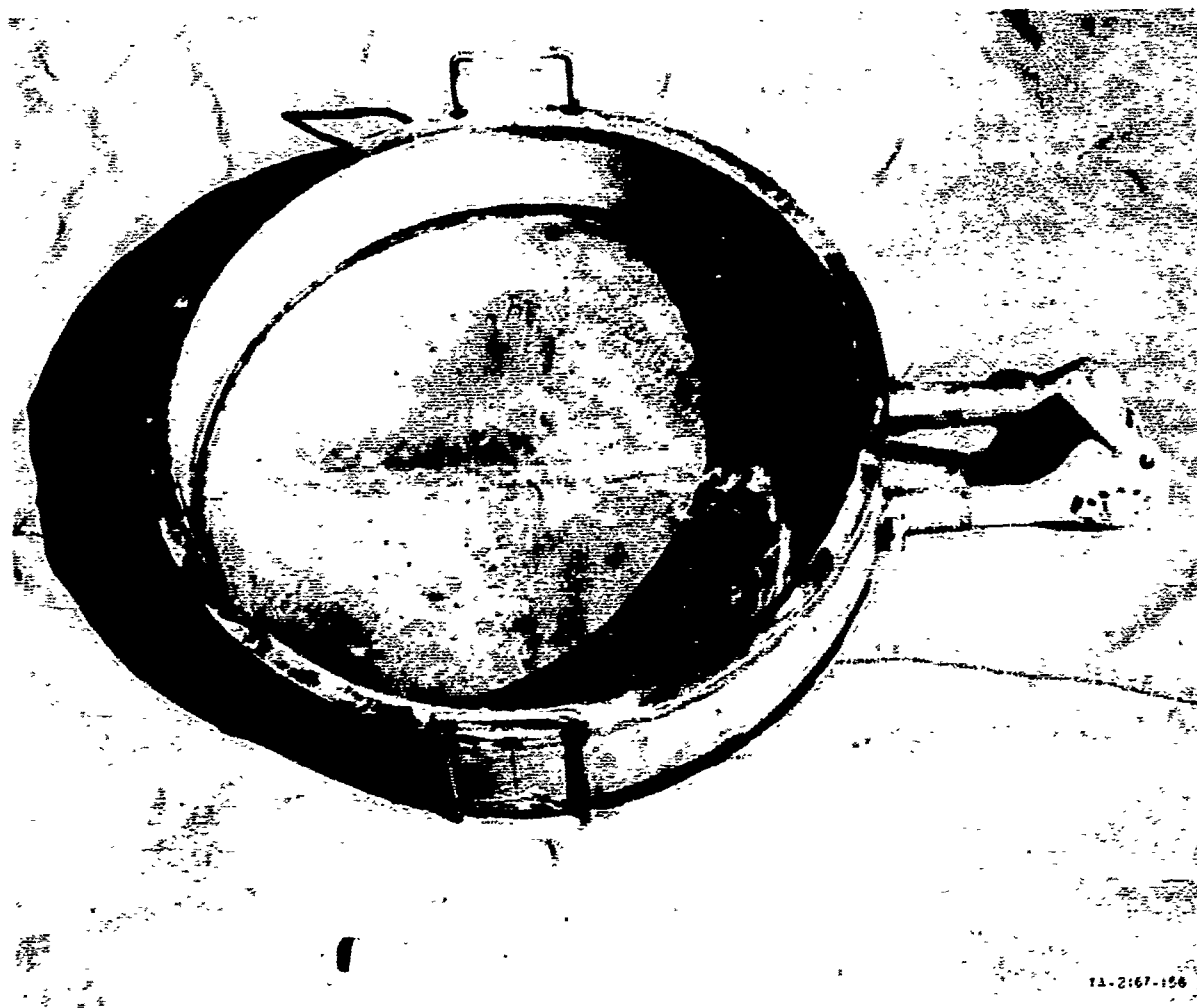

FIG. 3 DOUBLE-WALLED PAN AND HOT AIR BLOWER

The subzero test slab was manufactured in an identical manner with the exception that it was frozen in a commercial cold storage plant which operated at -30°F .

Typical test specimens, as received from the freezer, exhibited top and bottom surfaces which were both flat and parallel. The top surface of a typical warm sea ice ($+17^{\circ}\text{F}$) test slab was significantly harder and more solidified than the bottom surface which, as a result of the much higher salinity in the lower layer of the slab, had a tendency to be mushy. However, the subzero ice (-13°F) was completely solidified on both top and bottom layers and evidenced a surface hardness that was appreciably greater than that common to the typical warm ice test specimens.

The salinity content of the seawater as received was 30 ppm. Because of the qualitative nature of these experiments, a precise determination of the salinity profile through the thickness of each ice slab was not obtained. However, the results of two analyses on full core samples by titration for total halide content (Mohr procedure) yielded average salinity contents for the warm ice test specimens of 13 ppm and 19 ppm. For the subzero sea ice slab, a cored sample which was partitioned into three sections through the slab thickness yielded salinity contents of 6.15 ppm, 6.22 ppm and 7.61 ppm for the top 50%, middle 38% and bottom 12%, respectively. These numerical values are considerably lower than those obtained from the warm ice test specimens. Because only one subzero ice slab was prepared, it was not possible to qualify these results; thus, the reasons for the discrepancy is unknown.

No attempt was made to determine the density, brine content and porosity of the test slabs.

The basic equipment of the test facility (see Figure 4) consisted of a relatively large circular tank, the guide rails, the projectile mass and various penetrators.

The tank was a commercially available portable wading pool, 8 ft in diameter and 20 in. deep, consisting of a flexible corrugated metal wall which supported a polyvinyl liner. Eight hundred gallons of Pacific Ocean seawater were used to fill the pool. Initially, the tank water was

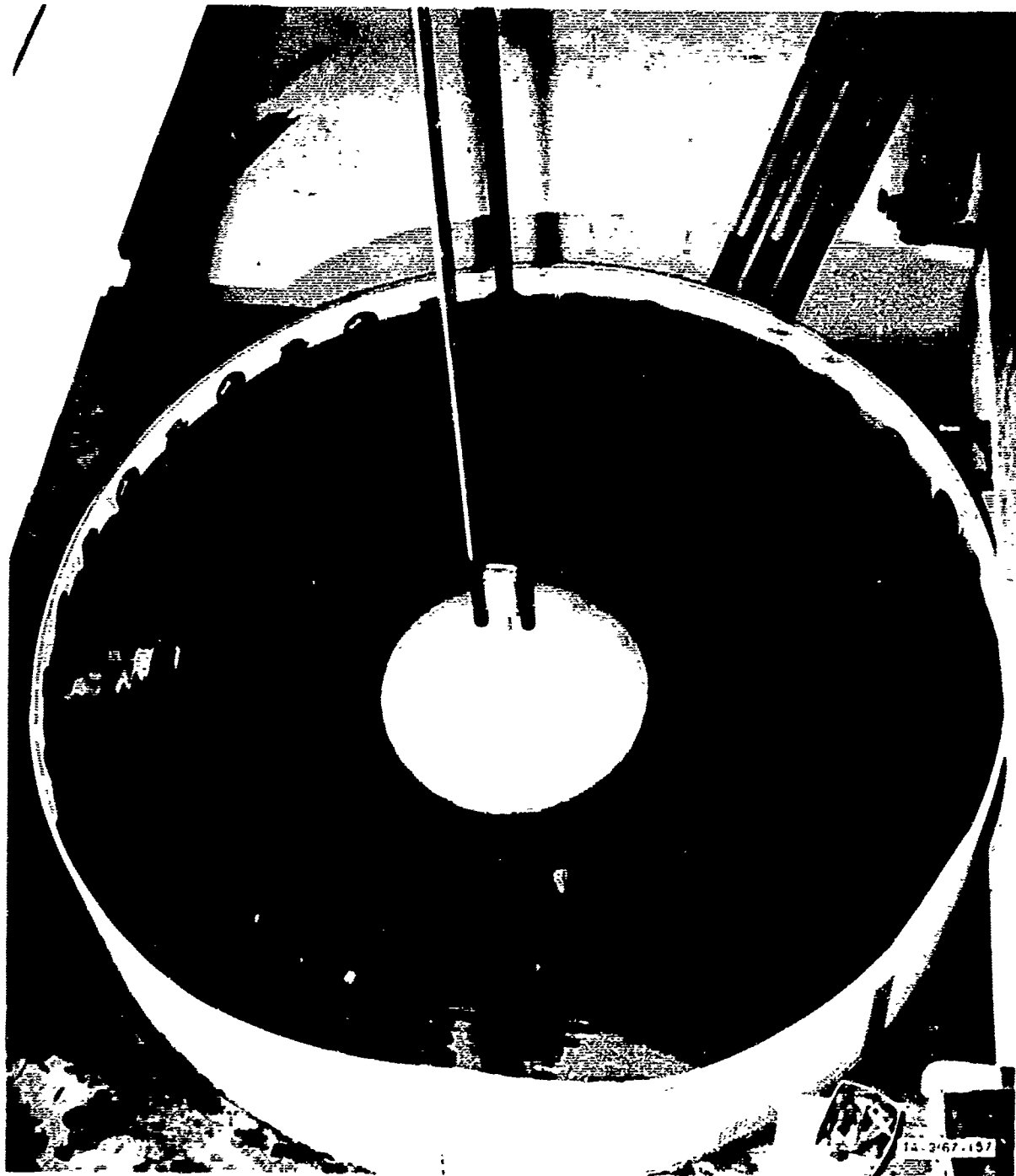

FIG. 4 TEST FACILITY

maintained at room temperature; however, in an effort to make the test conditions more analogous to those typical of the arctic, the tank water in later tests was cooled to $+29^{\circ}\text{F}$ by the addition of 500 lb of dry ice. The experiments were then conducted after the disappearance of all but very small chunks of the dry ice.

The guide rails were 1-1/4 in., O.D., commercial steel pipes supported and maintained 3-1/2 in. apart by spacer blocks which were fastened to a heavy roof beam. A scale, attached to one guide rail, provided a means of determining the free fall height which was the distance from the center of gravity of the penetrator mass to the ice slab's top surface.

The projectile mass comprised two side plates of stainless steel and a middle plate of brass. Four roller bearings were mounted on the side plates' edges to assist the free sliding motion of the mass in the guide rails. The various penetrators which could be screwed into the base of the projectile mass were made of aluminum. Figure 5 shows the projectile mass and penetrators; Table 2 summarizes data concerning the geometries and weights of these items.

Table 2
PENETRATOR SHAPES AND SIZES

PENETRATOR PROFILE	D	c	m_1	\bar{r}_1^2
	(in.)	(in.)	(slugs)	(lb)
Conical	0.3125	3.165	0.1430	4.60
Conical	0.500	3.210	0.1445	4.65
Conical	1.251	3.594	0.1595	5.14
Hemispherical	1.251	3.686	0.1608	5.17
Concave	1.250	3.656	0.1615	5.20
Blunt	0.3125	3.094	0.1418	4.50
Blunt	0.500	3.094	0.1438	4.63
Blunt	1.252	3.719	0.1620	5.22

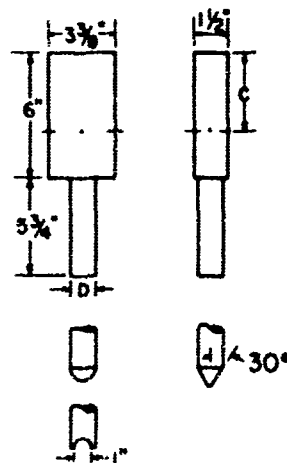

TA-2167-163

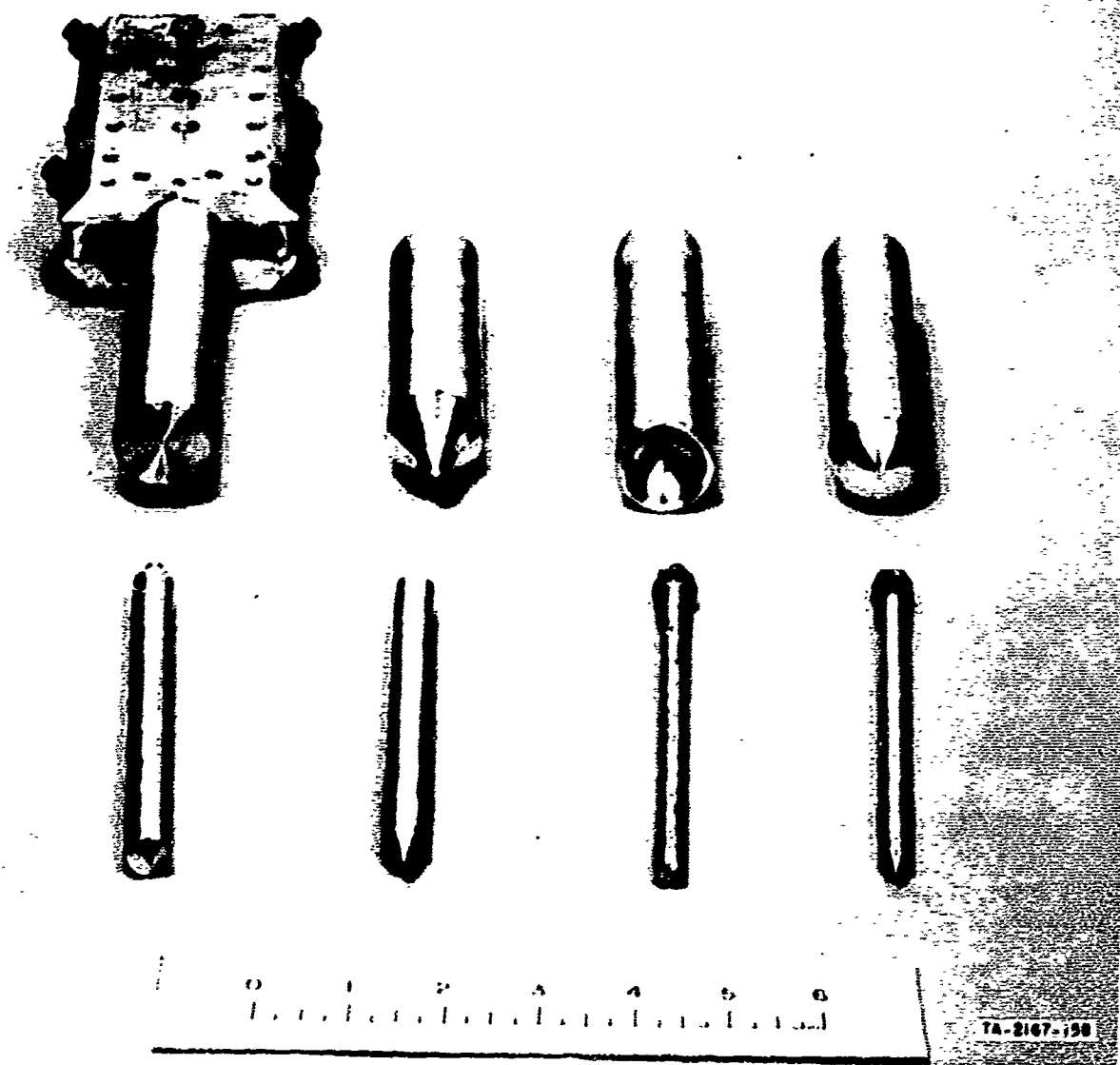

FIG. 5 PROJECTILE MASS AND VARIOUS PENETRATORS (scale in inches)

TEST PROCEDURE

The test procedure and set-up were essentially similar for all experiments with one exception, the details of which will be explained in a later paragraph.

The test slab was removed from the double-walled pan by submerging this unit in the tank of water and allowing the buoyant forces to float the slab free from the pan. The floating test slab was then centrally positioned under the guide rails that contained the freely sliding projectile mass and its various penetrators.

The projectile was released from a selected height and allowed to impact the floating test slab. The penetration process was observed, and whether perforation was achieved and the type of failure were recorded together with the following data: mass of the projectile including penetrator, diameter and profile shape of the penetrator, free fall height, thickness of the test slab, and temperature and specific gravity of the water in the tank. By means of embedded thermocouples, the temperature at the center as well as temperatures at midthickness, along a diameter, were obtained for some of the ice slabs.

The test configuration was significantly altered for one particular experiment. To investigate the effect of allowing the projectile to impact the test slab at an angle, the guide rails were tilted 30° to the vertical. The ends of the guide rails were approximately 8 to 10 in. above the test slab. Thus, actual impact was at an angle somewhat less than 30° .

In an attempt to determine the static shear yield stress of sea ice, two slabs were tested in a Baldwin Universal Testing Machine. For this purpose, the loading head was fitted with the 1-1/4 in. diameter blunt end penetrator so that loading conditions corresponded, geometrically at least, to those typical of the impact-penetration tests. During the loading process, the test slab was uniformly supported on its lower surface by a 1 in thick circular plywood panel which was raised 8 in. above the table of the testing machine on six columns of heavy duty steel pipe. A circular hole was cut out of the panel,

concentric with the cylindrical loading penetrator. Thus, the entire machine test set-up was conceived to assist the formation of a shear plug during machine loading.

TEST RESULTS

Although a few impact-penetration experiments were conducted with fresh water ice test slabs, only qualitative observations of the penetration process were recorded. Thus, for these cases no numerical data are presented in this report.

Numerical data from the tests on warm sea ice slabs (+17°F) are summarized in Table 1. Test Slabs Nos. I, II, III and VI were floated in water at room temperature, whereas Test Slab Nos. IV and V were floated in water that had been cooled to +29°F by the addition of dry ice.

Since perforation did not occur during the test on the subzero sea ice slab because of limitations of the test equipment (insufficient projectile mass and height to provide the necessary impact energy), numerical data are presented for this case. However, the qualitative information obtained from this experiment is described in the next section entitled Experimental Observations.

The results obtained from experiments on Slabs I through VI are shown in Figures 6 through 9, respectively. The ordinates indicate the available potential energy (free fall) while the abscissae represent a characteristic geometric quantity containing the penetrator diameter and the slab thickness. These coordinates were suggested by theory.* Figure 6, in particular, portrays the results of tests in which different diameter penetrators having conical profile shapes were employed. Figure 7 shows similar results for tests with blunt end profile shapes. The results of all tests in which impact occurred at normal incidence are summarized in Figure 8. Included in this figure are the data points from tests with hemispherical and concave penetrators. Finally, Figure 9 shows the results of tests in which the projectile mass impacted the test slab at a nominal angle of incidence of 30° to the vertical.

Temperature distribution and its variation with time are shown for a typical sea ice test specimen in Figure 10. The pertinent data were

* See section entitled Mathematical Model and Analysis.

obtained from a warm ice (+17°F) slab which floated in seawater at room temperature (+59°F).

The numerical data realized from static tests on sea ice slabs in the testing machine are presented in Table 3.

Table 3
TESTING MACHINE RESULTS *

TEST NO.	LOADING RATE	MAX LOAD	MAX STRESS
	(ft/sec)	(lb)	(lb in. ²)
1	0.093×10^{-3}	520	124
2	0.556×10^{-3}	1040	849
3	0.803×10^{-3}	380	310
4	5.190×10^{-3}	610	197
5	0.093×10^{-3}	520	124
6	0.556×10^{-3}	860	702
7	0.803×10^{-3}	590	481
8	5.190×10^{-3}	480	391
9	0.093×10^{-3}	600	489
10	0.556×10^{-3}	920	750
11	0.803×10^{-3}	700	570
12	5.190×10^{-3}	530	432

* 1 1/4 in. diameter blunt penetrator profile and 1 1/2 in. circular cutout in supporting board.

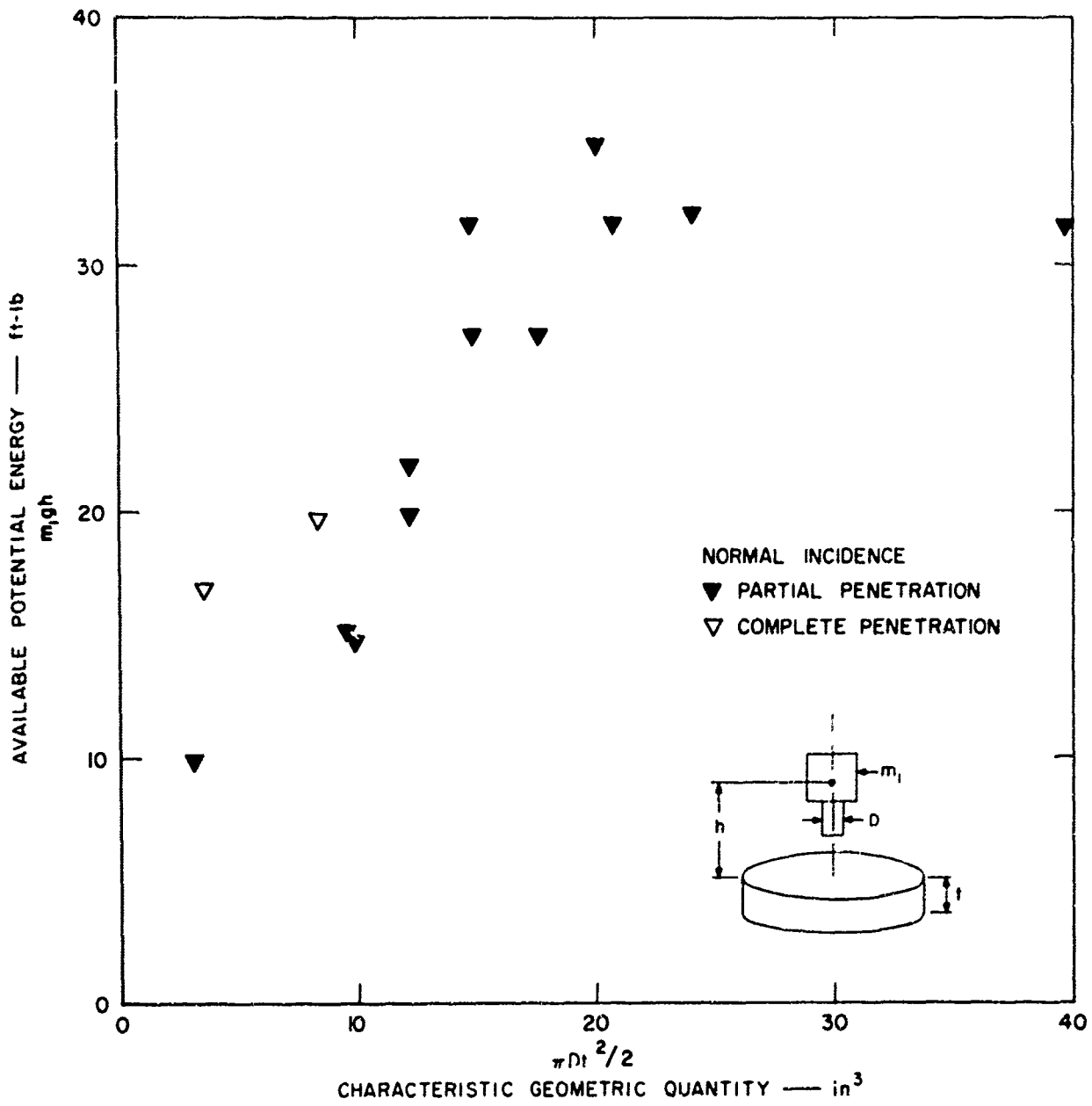

TB 2167-151

FIG. 6 PLOT OF TEST RESULTS OBTAINED WITH CONICAL PENETRATOR:
 WARM SEA ICE (+17°F)
 ▽ Conical Penetrator

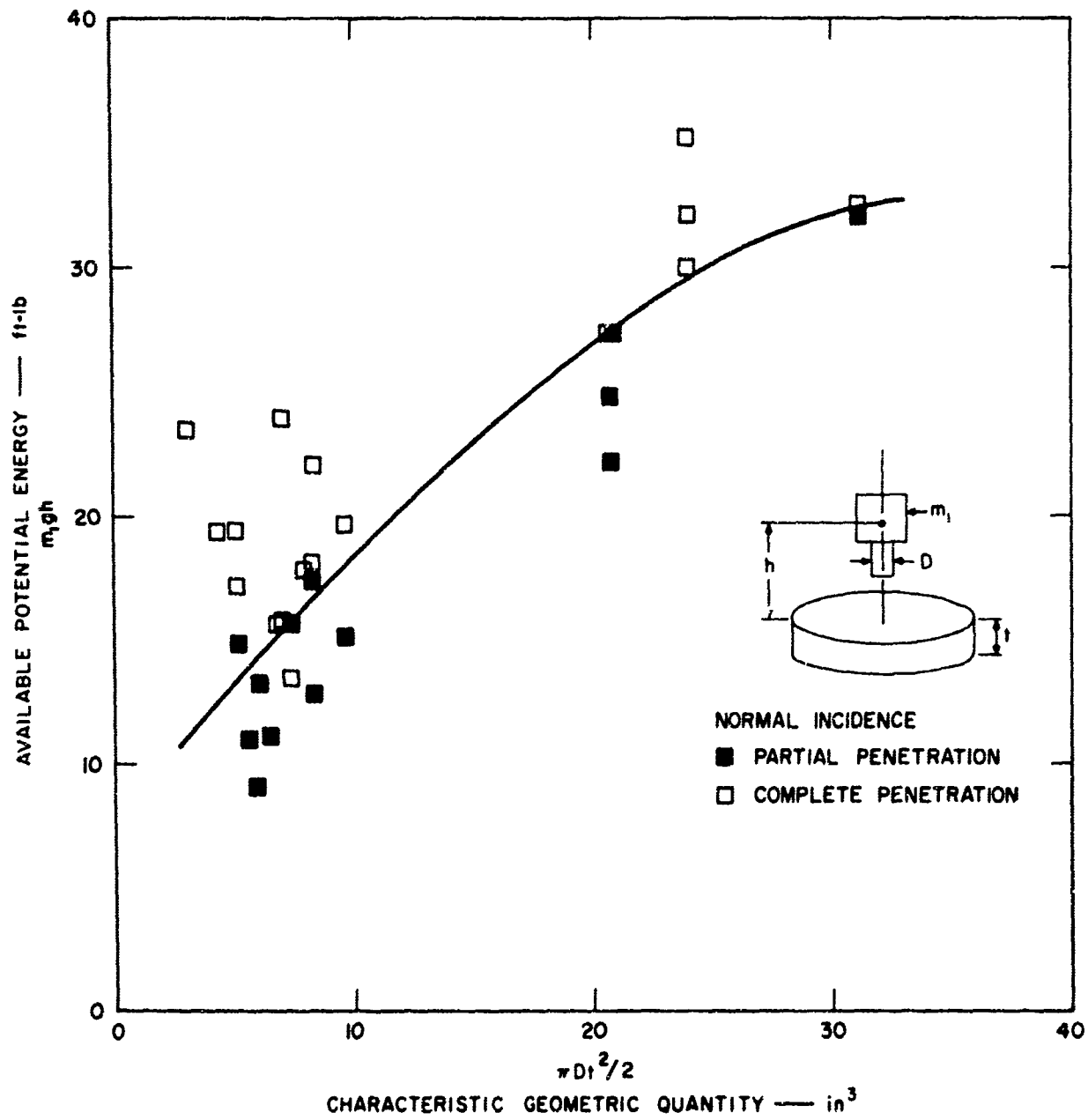

FIG. 7 PLOT OF TEST RESULTS OBTAINED WITH BLUNT END PENETRATOR:
 WARM SEA ICE (+17°F)
 □ Blunt Penetrator

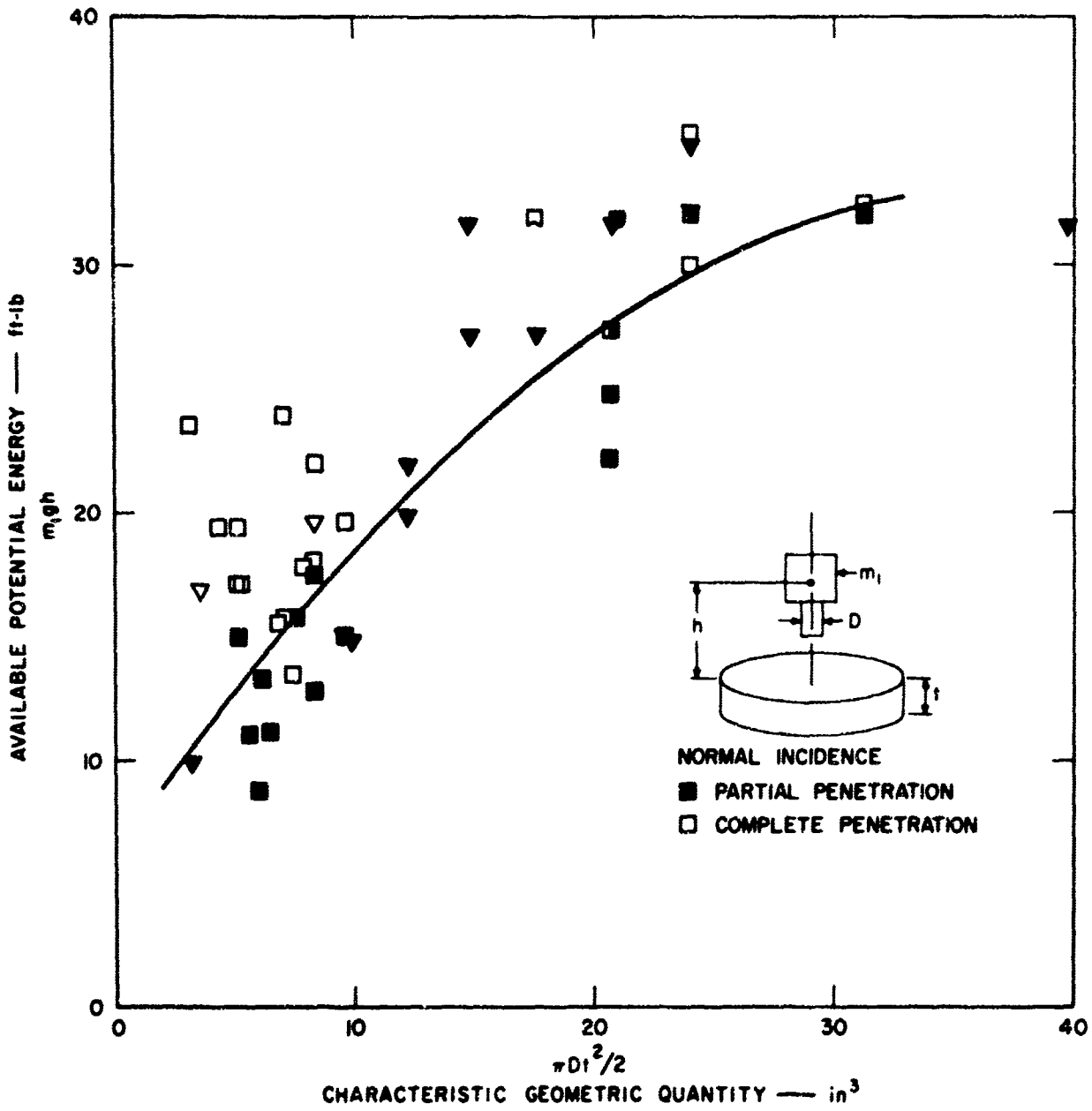

FIG. 8 PLOT OF TEST RESULTS OBTAINED WITH CONICAL, HEMISPHERICAL, CONCAVE AND BLUNT END PENETRATORS: WARM SEA ICE (+17°F)

▽	Conical Penetrator	◐	Hemispherical Penetrator
◑	Concave Penetrator	◻	Blunt Penetrator

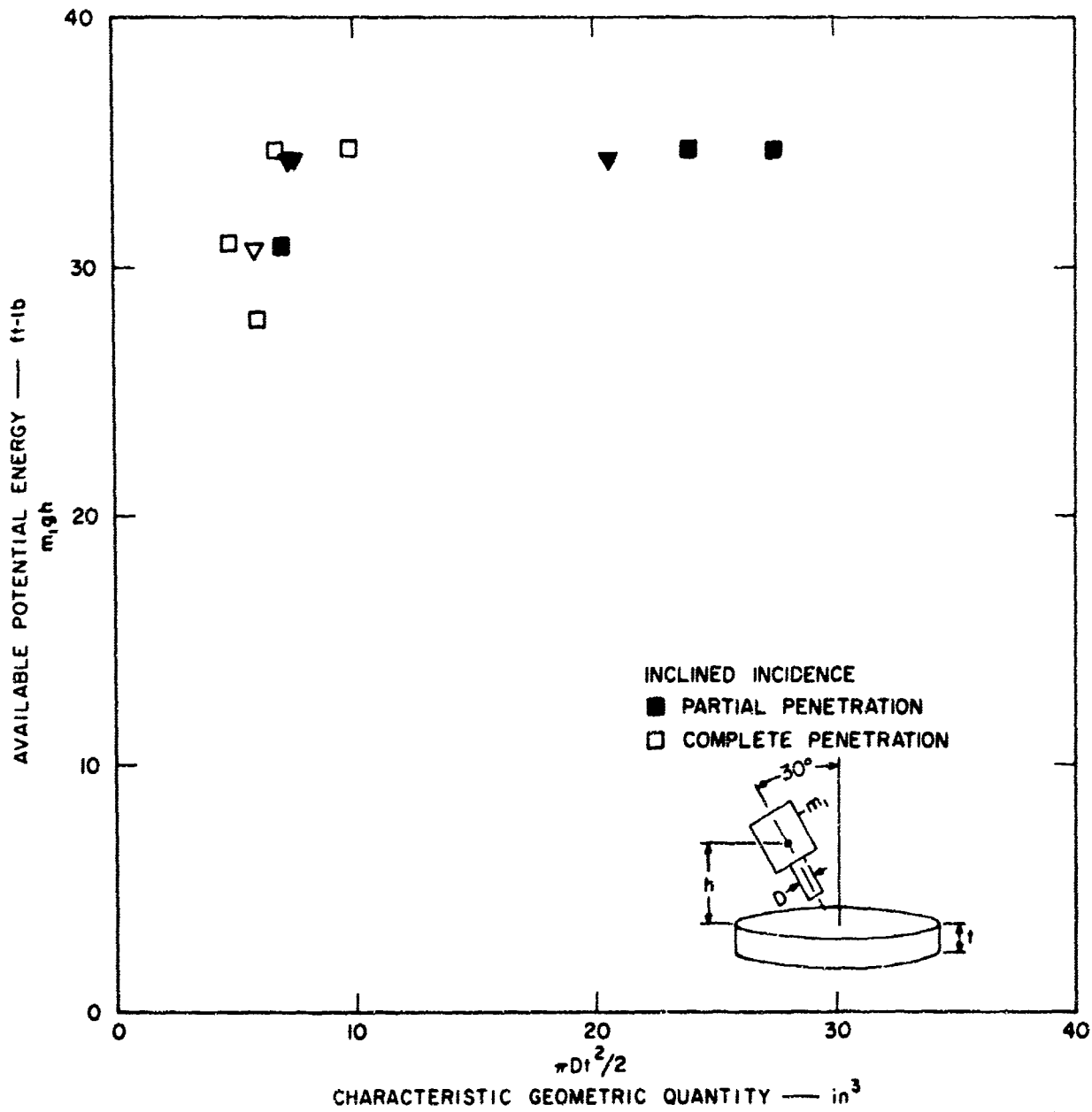

FIG. 9 PLOT OF TEST RESULTS OBTAINED WITH CONICAL AND BLUNT END PENETRATORS: WARM SEA ICE (+17°F)

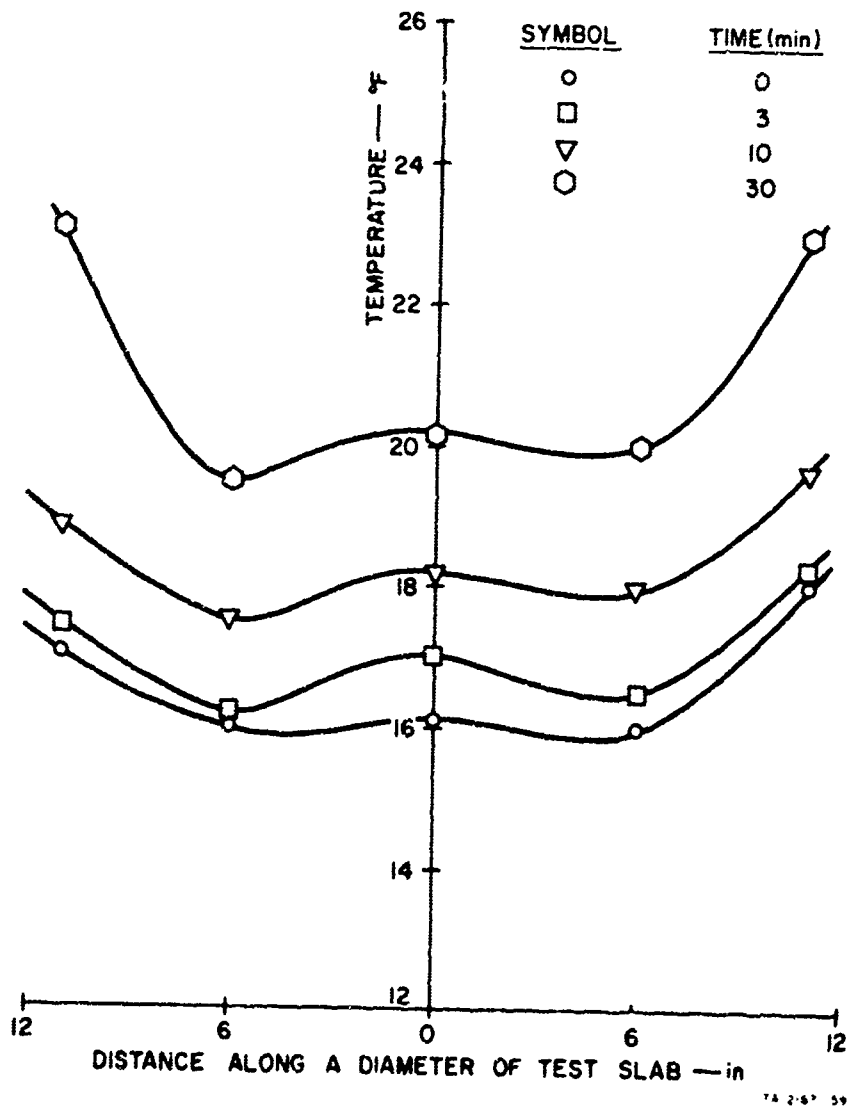

FIG. 10 TYPICAL TEMPERATURE PROFILES:
WARM SEA ICE (+17°F)

EXPERIMENTAL OBSERVATIONS

Fresh Water Ice Test Slabs

The initial series of penetration tests was conducted on test slabs of frozen tap water. These tests were qualitative in nature; their results proved useful in comparing the behavior of fresh water ice test slabs and sea ice test slabs.

Typical fresh water ice test slabs were approximately 3 in. thick. As a consequence of manufacturing the test slabs within the confines of a closed container, the ice showed random surface cracks, along chords, varying from 1/4 in. to 3/4 in. in depth.

The effects of impact which did not produce complete penetration were restricted to a relatively small volume of ice. In particular, visible local fracture planes issued from the point of contact (conical penetrator) at angles of approximately 45° down from the top surface of the test slab for distances of about 2 in. (see Figure 11-a).

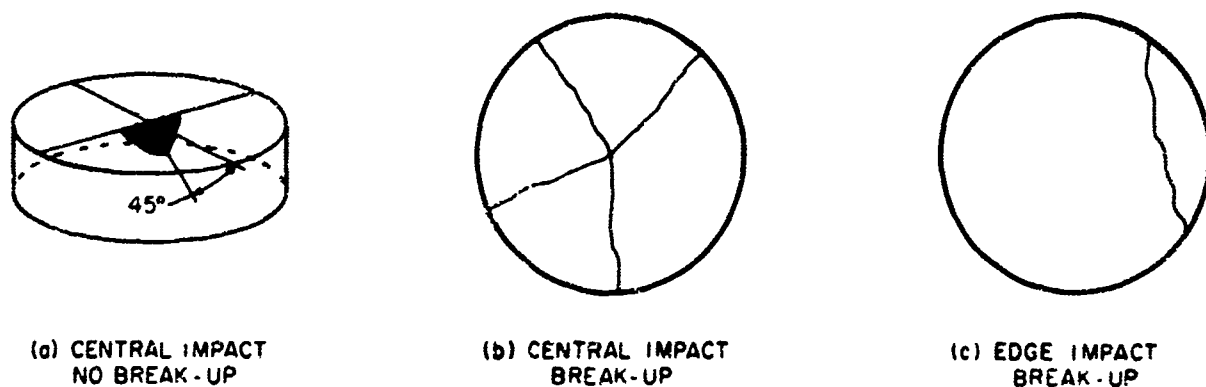

FIG. 11 VIEWS OF TEST SLAB AFTER IMPACT WITH 1-1/4 in. DIAMETER CONICAL PENETRATOR: FRESH WATER ICE

The test slabs which fractured did so by splitting into 3 or 4 pie-shaped segments outlined by radial cracks from the point of impact. The fracture surfaces between adjacent segments were perpendicular to both the top and bottom surfaces of the test slab. In addition, the

fracture surfaces were nearly straight in the radial direction (see Figure 11-b), and exceptionally smooth in appearance.

In some tests, impact was deliberately made to occur on the surface cracks which resulted during manufacture. Results of this experiment indicated that the presence of surface cracks did not contribute to the fracture process.

Test slabs which experienced edge impact close to the circular boundary rather than central impact split into two segments (see Figure 11-c).

On the basis of observations only, the conical penetrator was more effective than the blunt penetrator in producing complete fracture of the fresh water ice test slabs.

Sea Ice Test Slabs

The majority of tests were performed using test slabs of frozen seawater at approximate temperatures of +17°F. These tests furnished all of the numerical data presented in this report (see Table 1).

As a result of making the ice slabs in a closed container, the average salinity values, as well as the salinity distribution profiles through the slab thickness, proved to be an unrealistic representation of typical arctic sea ice. In particular, an accumulation of high salinity layers in the bottom portions of the test slab resulted in average salinities that were two to three times higher than corresponding values for arctic sea ice. For these reasons, a generalization of the present test results was not possible.

The results of initial tests, conducted with both conical and blunt end penetrators, indicated that the visible effects of impact were confined to the immediate area of penetrator contact. In cases where perforation did not occur, partial penetration was accompanied by plastic deformation of the adjacent ice. In many instances, partial entry of the penetrator into the top surface of the ice slab resulted in bulging of the bottom surface along the central axis of impact. A typical cross-sectional view of the ice slab (conical penetrator)

showed that a small volume of the material had undergone substantial plastic deformation delineated by a well-defined yield surface, as sketched in Figure 12.

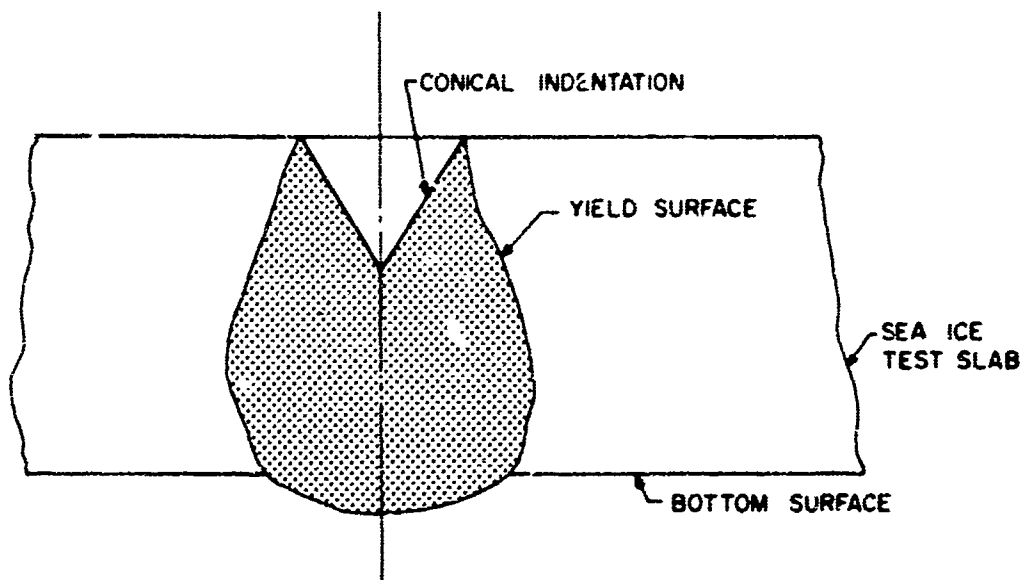

TA-2(67-6)

FIG. 12 VIEW OF CROSS-SECTION AFTER IMPACT WITH 1-1/4 in. DIAMETER CONICAL PENETRATOR: WARM SEA ICE (-17°F)

The impact of the penetrator on the sea ice test slabs did not produce surface cracks or fissures, nor fracture along cleavage planes. For every instance in which perforation occurred, a plug was sheared out of the ice slab. After ejection of the shear plug, the resulting hole in the ice slab was clean and circular at the top surface; however, at the bottom surface the hole was spalled and enlarged into a somewhat rectangular cross section. Even at the outer boundary of the ice, where the breaking off of edge sections might have been expected, a shear plug was ejected.

The results from all tests established the superiority of the blunt end penetrator over the conical penetrator. Specifically, for identical test conditions, impact of the conical penetrator produced limited penetration, with two exceptions, while the blunt penetrator perforated the ice readily. The shear plug mode of penetration suggested

the use of different penetrator profiles. As a consequence, tests were made with hemispherical and concave penetrators (see Figure 5). The relative performance of the hemispherical and concave penetrators was intermediate between that of the conical penetrator and the blunt penetrator.

The test results were not directly related to the temperature of the seawater in the tank. That is, results obtained from experiments in the tank containing water at +29°F were not noticeably different from those obtained with water at room temperature (+59°F). The blunt penetrator still perforated the test slab by expelling a shear plug, whereas the conical penetrator did not produce cracks or fissures which could break up the sea ice and result in perforation.

In certain tests, it appeared to observers that the passage of the projectile through the test slab was delayed during the perforation process.* The results obtained from these particular tests were used to describe the so-called threshold values of shear yield stress.

Experiments in which the projectile impacted the floating test slab along a path inclined slightly less than 30° to the vertical demonstrated that the conical penetrators, especially the largest diameter one, were incapable of perforating the test slab, being more ineffective in this case than in cases at normal incidence. After impact, the conical penetrator gouged out long troughs in the top surface of the sea ice. No significant penetration was obtained.

The first inclined impact tests with the blunt end penetrator caused the formation of asymmetric craters at the location of impact. However, subsequent tests on thinner test slabs produced both partial penetration and perforation through the mechanism of shear plug formation.

A series of impact tests was conducted on a subzero sea ice test slab (-13°F) floating in cold sea water (+29°F). Because of limitations on the kinetic energy of the projectile, the ice was not perforated. Instead, on impact, local fragmentation extended to a depth

* Generally, it was observed that the projectile sheared through the slab rapidly and without delay.

of approximately 1 in. when the largest diameter blunt end penetrator was used and partial penetration resulted with the smallest diameter conical penetrator, strongly indicating that the mechanisms of penetration are dependent on temperature.

In all tests performed, the relative scale of projectile, test slab and tank dimensions was such that impact of the falling projectile produced negligible motion of the test slab and virtually no wave motion of the water in the tank. Even in the tests where the ice slab was subjected to inclined impact forces, there was no noticeable horizontal motion of the slab.

Machine-Tested Sea Ice Slabs

During the first series of tests, the sea ice slab was supported on a plywood panel containing a 6-inch circular cutout. The ice slab, which was at a temperature of about +20°F, was tested at room temperature.

Application of the load caused local melting and crushing of the ice in the immediate vicinity of the blunt penetrator. No perceptible shear deformation nor any pushing out of a shear plug was evident. The maximum resisted load and subsequent failure occurred when the cutout area allowed the exposed bottom surface to bulge out causing random cracks or fissures in the protruding volume of ice.

In the second series of tests, the original supporting board was replaced by one which contained a 1-1/2-inch circular cutout. Otherwise, test conditions were similar to those of the initial series. It was hoped that this change in support conditions would enable the penetrator-slab combination to produce the anticipated shear plug deformation; however, this did not occur. Instead, local melting and crushing was noticed again, accompanied in this case by upsetting of the sea ice to form a collar around the penetrator shaft. Ultimately, the formation of cleavage planes resulted in the breaking up of the test slab into smaller segments.

The most significant result realized from the machine tests on the ice slabs was the compressive crushing type of failure obtained in contrast to the shear plug failure common in the impact-penetration tests. Since the loading rates associated with the latter tests were approximately a thousand times greater than those of the testing machine, a strong indication was provided that the penetration process can be dependent on both the kinetic energy or impact momentum of the projectile, and on the impact velocity itself.

Because of the difference in failure mode between machine and impact tests, it is not to be expected that the failure stresses observed in the one would apply in the other.

MATHEMATICAL MODEL AND ANALYSIS

For shear plug penetration, a simple mathematical model can be formulated. Based on the classical theory of impact, the equations describing the model behavior are governed by the law of conservation of momentum and the law of conservation of mechanical energy. No account is taken of transient stresses, nor are contact deformations and vibrations of the colliding bodies considered. In agreement with experimental observations, it is assumed that the impact is plastic (no rebound), and that the test slab remains motionless during the shear plug ejection process. Moreover, hydrodynamic drag forces and buoyant body forces on the plug, and sliding friction forces on the penetrator are neglected. Figure 13 shows the model and notation employed.

Conservation of linear momentum yields

$$m_1 v_1 = (m_1 + m_2) v_2 \quad (1)$$

where the assumption of plastic impact requires that both masses, m_1 and m_2 , travel with the same resulting velocity, v_2 , after collision. The free fall velocity of the penetrator mass, m_1 , just prior to impact is denoted by v_1 .

Conservation of mechanical energy provides a relationship between the amount of kinetic energy imparted to the projectile-plug combination immediately after impact and the amount of work expended in expelling the shear plug from the slab. Since this formulation can only relate initial and terminal velocity states, it is postulated that the plug velocity approaches zero at exit.

Thus,

$$\frac{1}{2} (m_1 + m_2) v_2^2 = \int_0^t \tau_{xy}(\eta, \dot{\eta}) \pi D (t - \eta) d\eta \quad (2)$$

where D is the shear plug diameter, assumed equal to the penetrator diameter, t the ice slab thickness and τ_{xy} the shear yield stress which

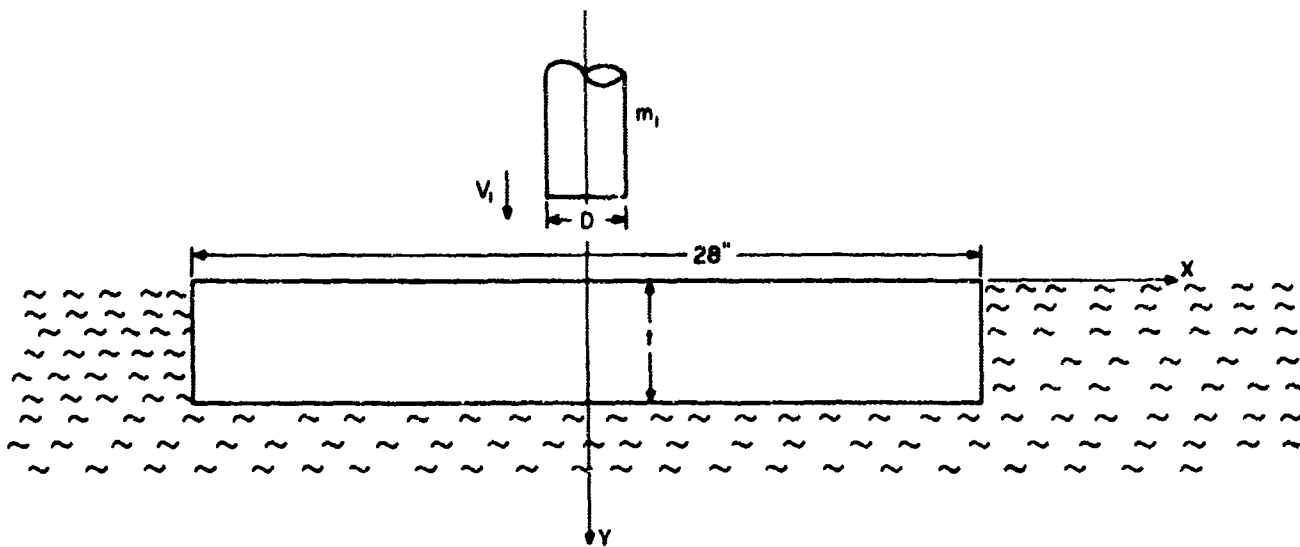

(a) PRIOR TO IMPACT

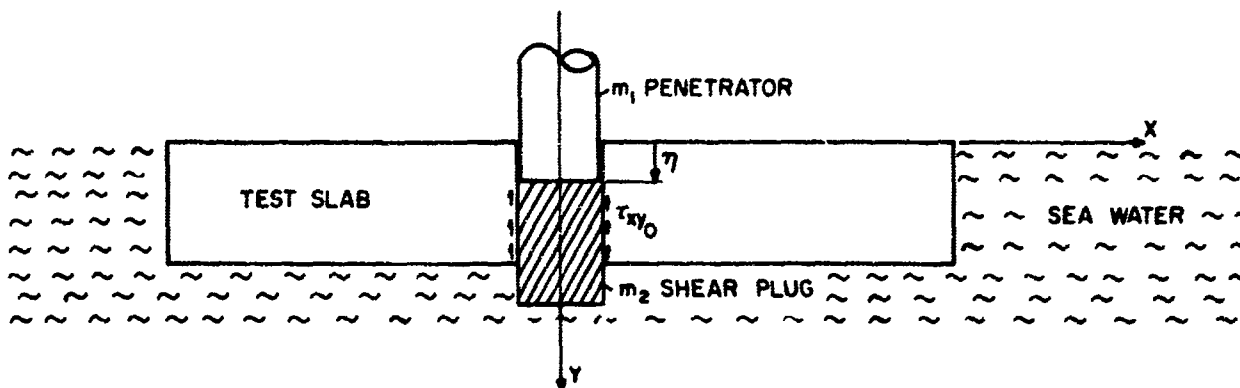

(b) AFTER IMPACT

Not to scale

Y6-2:67-190

FIG. 13 SKETCH OF MATHEMATICAL MODEL FOR SHEAR PLUG TYPE OF PENETRATION

is in general a function of both position, η , and velocity, $\dot{\eta}$. Substitution of the initial plug velocity, v_2 , from Eq. (1) into Eq. (2) yields

$$\frac{1}{2} \frac{m_1^2 v_1^2}{(m_1 + m_2)} = \int_0^t \tau_{xy}(\eta, \dot{\eta}) \pi D(t - \eta) d\eta \quad (3)$$

Since an experimental determination of the function $\tau_{xy}(\eta, \dot{\eta})$ was beyond the scope of the present investigation, a gross approximation was made to enable an evaluation of the work integral. Thus, the sea ice was assumed to exhibit rigid-plastic behavior* such that ejection of the shear plug occurred at a constant value of shear yield stress, τ_{xy0} . With this assumption and after performing the indicated integration, there results

$$\frac{1}{2} \frac{m_1^2 v_1^2}{(m_1 + m_2)} = \tau_{xy0} \frac{\pi D t^2}{2} \quad (4)$$

The impact velocity, v_1 due to free fall can be readily expressed in terms of the free fall height. After rearrangement, there results

$$\frac{m_1 g h}{(1 + \frac{m_2}{m_1})} = \tau_{xy0} \frac{\pi D t^2}{2} \quad (5)$$

For the quantities typical of the present experimental program,

$$\frac{m_2}{m_1} \ll 1 \quad (6)$$

so that

$$m_1 g h \approx \tau_{xy0} \frac{\pi D t^2}{2} \quad (7)$$

Eq. (7) relates the available potential energy, $m_1 g h$, to a characteristic geometric quantity, $\pi D t^2 / 2$. These two quantities were used to represent the data obtained from the experiments. It can be seen readily that, if the present shear plug model is valid, a knowledge of the shear yield stress function enables the free fall height for perforation to be obtained for a given projectile and ice slab.

* That is, elastic deformations prior to the formation of a plug are neglected.

DISCUSSION OF TEST DATA

An analysis of the simplified mathematical model representing the shear plug mechanism of penetration suggested that various fundamental quantities of the problem comprised two distinct groups. One of these groups, m_1gh , was equivalent to the available potential energy, whereas the other group, $\tau_{xy_0} \frac{\pi Dt^2}{2}$, represented the pertinent material and geometric parameters. Since no direct information concerning the shear yield stress, τ_{xy_0} , was obtained during the experiments, it was decided to portray all of the test results on plots with the known quantities m_1gh and $\pi Dt^2/2$ as ordinates and abscissae, respectively. In this way, characteristic values of τ_{xy_0} were realized from the plotted data.

Figure 6 depicts the test results obtained with conical penetrators. Different values of penetrator diameter, available potential energy and test slab thickness characterized these tests. Only two impacts were successful in perforating the sea ice test slabs. Both of these tests employed penetrators of 1/2 in. diameter. In general, relatively greater available potential energies and thinner test slabs were conducive to perforation at fixed values of penetrator diameter (e.g., test results*: III-3 and V-7 versus III-4, IV-12 and V-8); however, it is interesting to comment on the relative effectiveness of the conical penetrator at different penetrator diameters but nearly equivalent values of available potential energy (e.g., test results: V-7 and IV-11). Although Test No. IV-11 was carried out at a slab thickness of 2-1/2 in. while the slab thickness for Test No. V-7 was 3-1/4 in., perforation occurred in the latter case but not in the former. The location of these test results on the plot of Figure 6 indicates that this behavior is predicted by the theory.

A possible explanation of this phenomenon lies in the difference between the cylindrical surface areas associated with each penetrator. It is reasonable to assume that the shear yield stress was more or less constant for a given ice slab. Thus, during the perforation process, the resisting force was proportional to area or more concisely, the

* See Table 1.

penetrator diameter. As a result, a simple calculation shows that for the penetrators employed, 2-1/2 times greater resisting force prevailed in Test No. IV-11 ($d = 1-1/4$ in.), where perforation did not occur, when compared to Test No. V-7 ($d = 1/2$ in.), which was successful under similar test conditions.

Figure 7 shows the test results obtained with blunt end penetrators. Again, different values of penetrator diameter, available potential energy and test slab thickness were employed in these tests. The curve passes through the three threshold data points observed in the experiments*, and indicates a smooth, monotonically increasing threshold boundary for perforation. This boundary would be a straight line through the origin if the shear yield stress were equal for all test slabs. With minor exceptions, the impact tests that produced perforation lie above this boundary.

This type of plot furnishes the most significant information obtained from the ice penetration studies. If such a plot is found to be valid for real sea ice it can be used to predict a projectile's performance. That is, if a projectile of given mass and diameter is released from a particular height, a knowledge of the ice thickness will locate a coordinate position with respect to the threshold boundary. If this point lies above the boundary, perforation will result. In addition, the position of the point with respect to the threshold boundary should provide information concerning the probability of perforation. The threshold boundaries themselves depend on both the mechanism of penetration and typical yield stress values for the ice in question. The former factor appears to be strongly dependent on the characteristic ice temperature while the latter quantities are known to be functions of the ice salinity, brine content and temperature.

The relative performance of the various penetrator profiles can be seen in Figure 8 where the accumulation of data for all impact tests at normal incidence is plotted. Test results obtained at corresponding values of the characteristic geometric quantity, $\pi Dt^2/2$, indicate, on

* See page 26 for discussion of threshold values.

an energy basis, the superiority of the blunt end profile in the perforation process.

The results of tests in which the projectile impacted the test slab at an incline (see Figure 9) showed again that the conical penetrator was relatively ineffective in producing perforation. However, when sufficiently low values of slab thickness and penetrator diameter were involved, four impact tests out of five with the blunt end penetrator resulted in perforation.

The curves drawn in Figure 10 indicate the temperature profiles along a diameter at midthickness ($y = 2$ in.) of a typical test slab. The data for each profile were recorded at given times after placing the ice slab in the tank which contained water at room temperature.

Because of this large quantity of water, the slab temperatures increase with time, and at particular values of time the temperatures at points which are closest to the slab's outer edge are noticeably higher than the temperature at the center of the slab. The latter temperature was obtained at a point 1 in. above the bottom surface of the slab ($y = 3$ in.). This choice of thermocouple location resulted in the slightly higher temperatures at the slab's center.

Finally, it is interesting to examine the experimental points which have been described previously as threshold values. Thus, for Test Nos. II-1, II-3 and IV-2, simple calculations based on Eq. (7) yield respective values for the shear yield stress of 15.8 lb/in.^2 , 12.5 lb/in.^2 and 27.5 lb/in.^2 . These values, when corrected for the high salinity content of the present test slabs, appear reasonable if compared with field data (References 10, 11).

RECOMMENDED FUTURE INVESTIGATIONS

The present experimental program has suggested guide lines for conducting future research in the mechanics of ice penetration. For proper experiments, the following precautions are necessary:

Penetration tests should be carried out on sea ice slabs made under the most realistic conditions possible since questions concerning the use of a closed container to manufacture representative sea ice slabs prevented a generalization of results obtained in the present study. Thus, test specimens should be obtained from artificially frozen ice sheets formed on a relatively large volume of seawater. If necessary, the salinity of the underlying seawater should be controlled so that this quantity remains constant as the ice slab freezes and the brine content of the remaining seawater increases. In addition, the content of dissolved gases and organic matter in the frozen seawater should be monitored since it is known that the air bubble content of sea ice is important to its mechanical and physical properties (see Reference 10).

Experiments should be performed in a cold room where both the rate of freezing and temperature of the ice slabs can be varied. Because the physical properties of sea ice are difficult to define, it is not possible to work with theoretical scale models of the ice unless properties of this substance can be studied under controlled conditions.

Once the foregoing experimental procedure has been established, a large number of tests ought to determine the effect on the penetration process of the following variables:

ice slab

- rate of freezing
- temperature
- salinity
- brine content
- thickness

projectile

diameter
mass
shape
impact velocity

Of these parameters, the ice slab temperature and the projectile impact velocity are the most important; their consequences on the mechanism of penetration should be a major concern of any future test program. In this regard, the range of values investigated should include impact velocities up to 300 ft/sec and ice slab temperatures of +18°F to -15°F. Parenthetically, the impact velocity corresponds to a free fall height to 1400 ft while the temperatures encompass most normal strength sea ice.

The salinity of the ice slab per se and the diameter, mass and shape of the projectile are believed to be of secondary importance in the present penetration problem. Possible ranges of values for these quantities in future experiments are: salinity, 2 ppm - 20 ppm; diameter, 1/2 in. - 2 in. and mass, 2 lb - 15 lb. Both conical and blunt penetrators should be employed.

Of the remaining ice slab variables; rate of freezing and brine content are difficult to control while the thickness is of minor importance in the perforation process.

Because of the many variables involved, experimental techniques must be developed to study the influence of varying individual parameters while the others are held constant. It is possible that various mechanisms of perforation other than shear plug ejection can result from these tests.

In addition to conducting a large test program on properly manufactured test specimens and working in the cold room, future planning should also take into account the following tasks:

The applicability of the model test results to full-scale projectiles and actual sea ice should be determined. Thus, an extensive field test program must be conducted and the results obtained

interpreted in relation to the findings of the model study. With this information, relative size effects and the consequences of employing artificial ice made from seawater can be evaluated.

By recording resisting force-time histories during the penetration process, a closer understanding of the mechanism of perforation should be gained. From these data, a mathematical formulation of the critical yield stress function which includes strain rate effects can provide a more exact mathematical model relationship.

Further development of applicable mathematical models should accompany the experimental objectives of future investigations. Since values obtained for the mechanical properties of typical sea ice encompass a wide latitude, emphasis should be directed toward analyses indicating trends of behavior and the significance of individual parameters rather than producing close agreement with the experimental data obtained in model tests. Previous solutions (References 12, 13), which consider the plastic deformation and ultimate perforation of thin isotropic plates subjected to the loading of an impacting circular cylinder, could be extended to the three-dimensional, anisotropic ice slab to produce meaningful results.

Investigations concerning the dynamic material properties of both fresh water ice and sea ice are of importance and should be undertaken in conjunction with any future study of the penetration problem. Although a wide body of literature treating the static, creep and viscoelastic mechanical properties of ice is available (References 5, 10, 14), little or no data are available on the corresponding properties characteristic of rapid loading and impact loading. These latter cases, which introduce inertia effects to the problem, can possibly result in values for the material properties which differ significantly from the currently employed static values. Well-established techniques for the determination of dynamic properties have been pioneered in metal and ceramics technologies and should be applicable to ice studies.

The continued development of instrumentation devices that are conceived specifically for performing measurements in ice should be pursued. In this regard, an embedded device which is simple in operation, rugged and of low unit cost should prove most useful.

Finally, consideration should be given to the penetration of ice by methods other than falling projectiles. The feasibility of high explosive covers, explosive charges which are arrayed in distinct patterns to produce converging shock fronts and methanol surface flooding to reduce the ice breaking strength, should be studied.

REFERENCES

1. Vincendon, Maj. Pierre; The Far North, Military Review, September 1965.
2. Undersea Warfare in the Arctic Basin, RCA CR-63-527-2, 1963.
3. A Study of Arctic Undersea Warfare Through 1975, ARCOP Naval Analysis Report No. 25 (see also ONR Report No. ACR-NAR-25).
4. Goldsmith, W.; Impact, Edward Arnold Ltd., London, 1960, pp. 240-248.
5. Ice and Snow, edited by W. D. Kingery, M.I.T. Press, Cambridge, Mass., 1963.
6. Wilson, D. P.; The Arctic, a Selective Bibliography, NSL Technical Memo No. 904.3-03-64, 1964.
7. Pearce, D. C.; A Bibliography on Snow and Ice, NRC 2534, Division of Building Research, National Research Council, Ottawa, Canada.
8. Benert, R.; Penetration of Shaped Charges into Frozen Ground, CRREL TR 130, U.S. Army Materiel Command, Hanover, N.H., November 1963.
9. Charest, J., P. Duler and J. Rinehart; Mechanics of Penetration of Piles into Permafrost, CRREL TR 122, U.S. Army Materiel Command, Hanover, N.H., September 1965.
10. Zubov, N. N.; L'dy Arktiki (Arctic Ice), Izd. Glavesmorputi, Moscow, 1945.
11. Personal Communication from Mr. R. Paige, Polar Division, Naval Civil Engineering Laboratory, Port Hueneme, California.
12. Bachshian, F. A.; Viscoplastic Flow by Impact of a Cylinder upon a Plate (in Russian), Priklad. Mat. Mekh., Vol. 12, 1948, p. 47.
13. Kocketkov, A. M.; On the Propagation of Elastic-Viscous-Plastic Shear Waves in a Plate (in Russian), Priklad. Mat. Mekh., Vol. 14, 1950, p. 203.
14. Pounder, E. R. and E. M. Little; Some Physical Properties of Sea Ice, I, Canadian Journal of Physics. Vol. 37, 1959, p. 443.

DOCUMENT CONTROL DATA - R&D

(Security classification of title, body of abstract and indexing annotation must be entered when the overall report is classified)

1. ORIGINATING ACTIVITY (Corporate author)		2a. REPORT SECURITY CLASSIFICATION	
Stanford Research Institute Menlo Park, California		Unclassified	
		2b. GROUP	
		NA	
3. REPORT TITLE			
Penetration Studies of Ice with Application to Arctic and Subarctic Warfare			
4. DESCRIPTIVE NOTES (Type of report and inclusive dates)			
Final report			
5. AUTHOR(S) (Last name, first name, initial)			
Ross, Bernard			
6. REPORT DATE		7a. TOTAL NO. OF PAGES	7b. NO. OF REFS
November 1965		41	14
8a. CONTRACT OR GRANT NO.		8a. ORIGINATOR'S REPORT NUMBER(S)	
Nonr-2332(00)			
b. PROJECT NO.			
c.		8b. OTHER REPORT NO(S) (Any other numbers that may be assigned this report)	
d.			
10. AVAILABILITY/LIMITATION NOTICES			
Distribution Unlimited			
11. SUPPLEMENTARY NOTES		12. SPONSORING MILITARY ACTIVITY	
		Naval Ordnance Laboratory White Oak Silver Spring, Maryland	
13. ABSTRACT			
<p>Impact tests were made on floating ice slabs with particular attention devoted to the mechanism of penetration. The range of values investigated for the basic parameters was: impact velocity, 8 ft/sec - 21 ft/sec; projectile mass, 4.56 lb - 5.22 lb and penetrator diameter, 5/16 in. - 1-1/4 in. The perforation of ice slabs made from seawater, and at approximately +17°F (warm sea ice) is accompanied by the ejection of a shear plug from the test slab, whereas fresh water ice slabs under similar loading conditions fracture into segments along well defined radial cleavage planes. The experiments indicate that a blunt end penetrator profile is significantly more effective in the perforation of warm sea ice than a corresponding penetrator with conical profile. In addition, the order of magnitude of the impact velocity and temperature of the ice slab are important factors that can govern the mechanism of penetration. A simple mathematical model for shear plug ejection, based upon the laws of conservation of linear momentum and mechanical energy, provides correlation between a potential energy quantity containing projectile mass and release height, and a geometric quantity containing penetrator diameter and sea ice thickness. Using these quantities, curves are presented which indicate a threshold-of-perforation boundary for the warm sea ice. Finally, recommendations are made for guiding future investigations in this problem area.</p>			

14 KEY WORDS	LINK A		LINK B		LINK C	
	ROLE	WT	ROLE	WT	ROLE	WT

INSTRUCTIONS

1. **ORIGINATING ACTIVITY:** Enter the name and address of the contractor, subcontractor, grantee, Department of Defense activity or other organization (*corporate author*) issuing the report.

2a. **REPORT SECURITY CLASSIFICATION:** Enter the overall security classification of the report. Indicate whether "Restricted Data" is included. Marking is to be in accordance with appropriate security regulations.

2b. **GROUP.** Automatic downgrading is specified in DoD Directive 5200.10 and Armed Forces Industrial Manual. Enter the group number. Also, when applicable, show that optional markings have been used for Group 3 and Group 4 as authorized.

3. **REPORT TITLE.** Enter the complete report title in all capital letters. Titles in all cases should be unclassified. If a meaningful title cannot be selected without classification, show title classification in all capitals in parenthesis immediately following the title.

4. **DESCRIPTIVE NOTES:** If appropriate, enter the type of report, e.g., interim, progress, summary, annual, or final. Give the inclusive dates when a specific reporting period is covered.

5. **AUTHOR(S):** Enter the name(s) of author(s) as shown on or in the report. Enter last name, first name, middle initial. If military, show rank and branch of service. The name of the principal author is an absolute minimum requirement.

6. **REPORT DATE.** Enter the date of the report as day, month, year, or month, year. If more than one date appears on the report, use date of publication.

7a. **TOTAL NUMBER OF PAGES:** The total page count should follow normal pagination procedures, i.e., enter the number of pages containing information.

7b. **NUMBER OF REFERENCES:** Enter the total number of references cited in the report.

8a. **CONTRACT OR GRANT NUMBER.** If appropriate, enter the applicable number of the contract or grant under which the report was written.

8b, 8c, & 8d **PROJECT NUMBER:** Enter the appropriate military department identification, such as project number, subproject number, system numbers, task number, etc.

9a. **ORIGINATOR'S REPORT NUMBER(S):** Enter the official report number by which the document will be identified and controlled by the originating activity. This number must be unique to this report.

9b. **OTHER REPORT NUMBER(S).** If the report has been assigned any other report numbers (*either by the originator or by the sponsor*), also enter this number(s).

10. **AVAILABILITY/LIMITATION NOTICES:** Enter any limitations on further dissemination of the report, other than those

imposed by security classification, using standard statements such as:

- (1) "Qualified requesters may obtain copies of this report from DDC."
- (2) "Foreign announcement and dissemination of this report by DDC is not authorized."
- (3) "U. S. Government agencies may obtain copies of this report directly from DDC. Other qualified DDC users shall request through _____."
- (4) "U. S. military agencies may obtain copies of this report directly from DDC. Other qualified users shall request through _____."
- (5) "All distribution of this report is controlled. Qualified DDC users shall request through _____."

If the report has been furnished to the Office of Technical Services, Department of Commerce, for sale to the public, indicate this fact and enter the price, if known.

11. **SUPPLEMENTARY NOTES:** Use for additional explanatory notes.

12. **SPONSORING MILITARY ACTIVITY.** Enter the name of the departmental project office or laboratory sponsoring (*paying for*) the research and development. Include address.

13. **ABSTRACT:** Enter an abstract giving a brief and factual summary of the document indicative of the report, even though it may also appear elsewhere in the body of the technical report. If additional space is required, a continuation sheet shall be attached.

It is highly desirable that the abstract of classified reports be unclassified. Each paragraph of the abstract shall end with an indication of the military security classification of the information in the paragraph, represented as (TS), (S), (C), or (U).

There is no limitation on the length of the abstract. However, the suggested length is from 150 to 225 words.

14. **KEY WORDS:** Key words are technically meaningful terms or short phrases that characterize a report and may be used as index entries for cataloging the report. Key words must be selected so that no security classification is required. Identifiers, such as equipment model designation, trade name, military project code name, geographic location, may be used as key words but will be followed by an indication of technical context. The assignment of links, rules, and weights is optional.