

AD 628054

Columbia University
New York

DEPARTMENT OF CIVIL ENGINEERING
AND ENGINEERING MECHANICS



CLEARINGHOUSE
FOR FEDERAL SCIENTIFIC AND
TECHNICAL INFORMATION

Microform	104	104	104
4.00	0.75	104	104

ARCHIVE COPY

Code 1

Step Load Moving with Superseismic Velocity on the
Surface of an Elastic-Plastic Half-Space

by

H. H. Bleich and A. T. Matthews

Office of Naval Research
Project NR 064-428
Contract Nonr-266(86)
Technical Report No. 38
U-4-65 ONR-266(86)-CE

December 1965

Reproduction in whole or in part is permitted for any purpose
of the United States Government

Columbia University
in the City of New York

**DEPARTMENT OF CIVIL ENGINEERING
AND ENGINEERING MECHANICS**



Step Load Moving with Superseismic Velocity on the
Surface of an Elastic-Plastic Half-Space

by

H. H. Bleich and A. T. Matthews

Office of Naval Research
Project NR 064-428
Contract Nonr-266(86)
Technical Report No. 38
CU-4-65 ONR-266(86)-CE

December 1965

Reproduction in whole or in part is permitted for any purpose
of the United States Government

ABSTRACT

The plane strain problem of a step load moving with uniform superseismic velocity $V > c_p$ on the surface of a half-space is considered for an elastic-plastic material obeying the von Mises yield condition.

Using dimensional analysis the governing quasi-linear partial differential equations are converted into ordinary nonlinear differential equations which are solved numerically using a digital computer. To overcome computing difficulties asymptotic solutions are derived in the vicinity of a singular point of the differential equations.

Typical numerical results are presented for selected values of significant non-dimensional parameters, i.e. of the surface load p_0/k , of Poisson's ratio ν , and of the velocity ratio V/c_p .

TABLE OF CONTENTS

Abstract	iii
Table of Contents	v
List of Symbols	vii
1. Introduction	1
2. Formulation of the Basic Equations	5
3. Solutions for Individual Regions	19
a) Nondissipative Regions	19
(1) The P-front	20
(2) The S-front	22
b) Plastic Regions	23
c) Discontinuities (Shock Fronts)	26
d) Asymptotic Solutions near Singularities	28
4. Construction of Solutions	36
a) Solutions in Range I	40
b) Solutions in Range II	43
c) Alternative Solutions and Considerations of Uniqueness and Existence	44
5. Results and Conclusions	49
a) Discussion of Typical Numerical Results	49
b) Conclusions	52
Appendix A - Asymptotic Solution of Equations (3-35,36,37)	56
Appendix B - Proof for the Hyperbolic Character of Equations (2-14,15) and Bounds on Charac- teristics	61
References	73
Figures	75

BLANK PAGE

3

LIST OF SYMBOLS*

$a_{1\dots 4}$	Functions defined by Eqs. (3-39).
$b_{1\dots 4}$	Functions defined by Eqs. (3-14)-(3-16) and (3-26).
c_P, c_S, \bar{c}	Velocity of propagation of elastic P-waves, S-waves and of inelastic shock fronts, respectively.
F	Plastic potential, Eq. (2-1).
G	Shear modulus.
J_1, J_2'	Invariants of stress.
k	Yield stress in shear, Eq. (2-1).
$K = \frac{2(1+\nu)}{3(1-2\nu)} G$	Bulk modulus.
$L > 0$	Function related to inelastic behavior, Eq. (2-36).
$p(x-Vt)$	Surface pressure.
p_E, p_L, p_O	Intensities of step load surface pressure.
R	Variable defined by Eq. (2-19).
s_1, s_2	Principal stress deviators.
s_x, s_y, s_{ij}	Stress deviators with respect to axes x,y, etc.
t	Time.
$v_x, v_y, \dot{v}_x, \dot{v}_y$	Components of particle velocity and acceleration in x and y directions, respectively.
V	Velocity of surface pressure.

*) Other symbols, which are used in one location only, are defined as they occur.

x, y	Cartesian coordinates, Fig. 1.
$X = \frac{\rho V^2}{2G} \sin^2 \phi$	Nondimensional expression.
X_P, X_S	Values of X at P- and S-fronts, respectively.
$\beta = \frac{s_1 - s_2}{s_1 + s_2}$	Nondimensional stress variable.
γ	Angle between the directions of s_1 and of the position ray of an element, Fig. 4.
$\Delta \equiv \beta - 3$	Small quantity for purposes of asymptotic expansion.
$\Delta\sigma, \Delta v, \Delta\tau, \text{ etc.}$	Increments of $\sigma, v, \tau, \text{ etc.}$ at a front.
$\epsilon \equiv \phi - \bar{\phi}$	Small quantity for purposes of asymptotic expansion.
$\epsilon_{ij}, \dot{\epsilon}_{ij}$	Strains, strain-rates.
$\eta \equiv \gamma - \frac{\pi}{2}$	Small quantity for purposes of asymptotic expansion.
θ	Angle defining direction of the principal stress σ_1 , Fig. 4.
$\lambda > 0$	Function related to inelastic behavior, Eq. (2-8).
ν	Poisson's ratio.
$\xi \equiv x - Vt$	Variable defined by Eq. (2-13).
ρ	Mass density of medium.
$\sigma_{ij}, \dot{\sigma}_{ij}$	Stresses, stress rates.
$\sigma_1, \sigma_2, \sigma_3$	Principal Stresses.
τ	Shear stress.

ϕ Position angle of element, Fig. 4.

$\phi_P, \phi_S, \bar{\phi}$ Position of the elastic P- and S- and of the inelastic shock fronts, respectively.

$\phi_1, \phi_2, \phi_3, \phi_4$ Limits of inelastic regions.

$\dot{}$ Differentiation with respect to ϕ .

BLANK PAGE

1. INTRODUCTION.

The two dimensional steady-state problem considering the effect of a pressure pulse $p(x - Vt)$ progressing with the velocity V on the surface of an elastic half-space, Fig. 1, has been treated by Cole and Huth [1] for a line load. By superposition their solution may be used to find the effect for any other distribution $p(x - Vt)$. The equivalent problem for linearly viscoelastic materials was treated by Sackman [2], and Workman and Bleich [3], in the superseismic and subseismic ranges, respectively. The present paper considers the problem again, but in an elastic-plastic material subject to the von Mises yield condition. In this material the problem becomes non-linear, so that superposition is not permitted and each pressure distribution $p(x - Vt)$ poses a separate problem. The present paper treats only the case of a progressing step load $p(x - Vt) \equiv p_0 H(Vt - x)$.

Interest in steady-state problems is not only due to the fact that they are natural stepping stones towards physically more meaningful, but more complex nonsteady problems. In the elastic case Miles [4] has considered the three dimensional problem of loads with axially symmetric distribution $p(r,t)$ over an expanding circular area on the surface, Fig. 2. He has demonstrated that the plane problem [1] is the asymptotic

solution for the three dimensional one in the region near the wave front. This gives rise to the expectation that the situation in other materials may be similar. This motivation for the search for steady-state solutions limits interest to those which do not violate conditions which asymptotic solutions of three dimensional problems must satisfy.

The conditions to be imposed on steady-state solutions to eliminate any which are not asymptotic solutions of the problem in Fig. 2, or of a similar one, can easily be recognized in the elementary example of a half-space of an inviscid compressible fluid loaded by a uniform pressure pulse p , which progresses with supersonic velocity, $V > c$. There is an obvious solution, Fig. 3a, in which the load produces a plane wave of intensity p progressing with a front inclined at the appropriate angle $\psi = \sin^{-1} \frac{c}{V}$. However, this is not the only steady-state solution. An alternative is a plane wave, the front of which is inclined at the angle $180^\circ - \psi$. Combinations of the two solutions are also correct steady-state solutions. To find states generated by the application of a progressing pressure on the surface only, it can be reasoned that solutions which include the wave front shown in Fig. 3b can not apply because the medium ahead of the front shown in Fig. 3a should be undisturbed when the applied load advances from the left with supersonic velocity. Further, the transient supersonic

solution being irrotational without a singularity in pressure or velocity at the wave front, the same must hold in the steady-state. This reasoning leads to unique steady-state solutions for fluids and also for elastic materials in supersonic and superseismic cases, respectively. An equivalent approach will be utilized in this paper^{*)}.

In elastic-plastic materials different sets of differential equations apply in the elastic, or neutral, and in the plastic regions. The fact that these regions have moving, a priori unknown boundaries, complicates the solution of dynamic problems considerably. In the following, the basic equations will be formulated and solved separately in plastic and in nondissipative regions. The partial solutions will be matched to obtain a complete one satisfying the prescribed surface conditions and additional ones obtained from the requirement that the steady-state solutions should qualify as asymptotic for a transient problem of the type shown in Fig. 3. Using dimensional analysis, similar to the approach used in a simpler case, [5] permits transformation of the original nonlinear partial differential equations in plastic regions into a set

*)

In subsonic or subseismic cases the equivalent approach is not fully successful. For example, in elastic materials the steady-state solution in the subseismic range is unique for many, but not for all quantities. Expressions for the horizontal stress and for the velocities contain arbitrary constants which can not be determined.

of simultaneous ordinary ones. Their solution in the non-dissipative case is elementary. Those in the plastic case are nonlinear and much too complex for closed solution, but they can be solved numerically requiring the solution of transcendental equations and quadratures, for both of which digital computers are employed. Break down of the computer solutions in the vicinity of a singular point of the set of differential equations made the derivation of asymptotic solutions necessary.

While the solution of the problem is obtained without overt use of characteristic methods, it is actually dependent on the hyperbolic character of the quasi-linear differential equations. As a matter of fundamental interest it is proved in Appendix B that the steady-state problem in plastic regions is hyperbolic for superseismic velocities $V > c_p$.

2. FORMULATION OF THE BASIC EQUATIONS.

Figure 4 indicates the half-space and a system of Cartesian coordinates. The x-axis is in the direction of motion of the step load, the y- and z-axes are normal to the surface in and out of the plane of the figure, respectively. The analysis considers the case of plane strain, $\epsilon_z = 0$, when the velocity V of the step load is superseismic, i.e. larger than the largest elastic or plastic wave velocity, which is the one of elastic P-waves in the material. Throughout the analysis it is assumed that the strains and velocities are small, so that their higher powers may be neglected in comparison to linear terms.

To describe the behavior of the elastic-plastic material the yield function F is introduced

$$F \equiv J'_2 - k^2 \quad (2-1)$$

where J'_2 is the invariant

$$J'_2 = \frac{1}{2} s_{ij} s_{ji} \quad (2-2)$$

and the value $k > 0$ is the yield stress in shear.

The behavior of an element of the material is defined by

the following statements.

1. The value of the function F may never be positive

$$F \leq 0 \quad (2-3)$$

2. If, in an element of the material at a given instant,

$$F < 0 \quad (2-4)$$

the rates of change in stress and strain are related by the conventional elastic relations.

3. However, if the yield condition

$$F = 0 \quad (2-5)$$

is satisfied, three possibilities exist: a., in the next instant of time the material may be in a state of plastic deformation; b., it may be in a state of elastic unloading; c., it may be in a neutral state.

- a. If the material is in a state of plastic deformation

$$\dot{F} = 0 \quad (2-6)$$

the total strain rate will be the sum of an elastic and a plastic portion

$$\dot{\epsilon}_{ij} = \dot{\epsilon}_{ij}^E + \dot{\epsilon}_{ij}^P \quad (2-7)$$

where $\dot{\epsilon}_{ij}^E$ is obtained from the conventional elastic relations, while, based on the concept of a plastic potential,

$$\dot{\epsilon}_{ij}^P = \lambda \frac{\partial F}{\partial \sigma_{ij}} \quad (2-8)$$

λ which must be positive

$$\lambda > 0 \quad (2-9)$$

is an a priori unknown function of space and time, to be found as part of the solution of the problem.

- b. In case of elastic unloading $\dot{F} < 0$ holds, and the elastic stress-strain relations apply.
- c. In the neutral state \dot{F} vanishes as in case a., but neither energy dissipation nor permanent deformation occurs, and the elastic stress-strain relations apply. In the present problem neutral regions of a particularly simple type will be encountered in which neither the stress nor the

strain changes, $\dot{\epsilon}_{ij} \equiv \dot{\sigma}_{ij} \equiv 0$.

For the purpose of this paper it is convenient to combine elastic and neutral regions, which will be called "nondissipative", as opposed to plastic regions, where $\lambda > 0$, indicating that energy is dissipated. In the nondissipative regions the changes in stress and strain are governed by the elastic relations, while in plastic regions, Eqs. (7) and (8) apply. Formally, the equations in nondissipative regions can therefore be obtained by substitution of $\lambda = 0$ into the differential equations derived below for the plastic regions, and by replacing the conditions $F = \dot{F} = 0$ by the inequality (3).

Substituting Eqs. (7) and (8) and the elastic stress-strain relations into the relation

$$\dot{\epsilon}_{ij} = \frac{1}{2} (v_{i,j} + v_{j,i}) \quad (2-10)$$

the following constitutive equations are obtained for the case of plane strain

$$\left. \begin{aligned} \frac{1}{2G} \dot{s}_x + \frac{1-2\nu}{6(1+\nu)G} \dot{J}_1 + \lambda s_x &= \frac{\partial v_x}{\partial x} \\ \frac{1}{2G} \dot{s}_y + \frac{1-2\nu}{6(1+\nu)G} \dot{J}_1 + \lambda s_y &= \frac{\partial v_y}{\partial y} \end{aligned} \right\} \quad (2-11a)$$

$$\left. \begin{aligned} \frac{1}{2G} \dot{\tau} + \lambda \tau &= \frac{1}{2} \left(\frac{\partial v_x}{\partial y} + \frac{\partial v_y}{\partial x} \right) \\ \frac{1}{2G} (\dot{s}_x + \dot{s}_y) - \frac{1-2\nu}{6(1+\nu)G} \dot{J}_1 + \lambda (s_x + s_y) &= 0 \end{aligned} \right\} (2-11b)$$

J_1 is the first invariant of stress, s_x , s_y and v_x , v_y are, respectively, the stress deviators, and the components of the particle velocity in the x and y directions.

Further, there are two equations of motion

$$\left. \begin{aligned} \frac{\partial s_x}{\partial x} + \frac{1}{3} \frac{\partial J_1}{\partial x} + \frac{\partial \tau}{\partial y} &= \rho \frac{\partial v_x}{\partial t} \\ \frac{\partial s_y}{\partial y} + \frac{1}{3} \frac{\partial J_1}{\partial y} + \frac{\partial \tau}{\partial x} &= \rho \frac{\partial v_y}{\partial t} \end{aligned} \right\} (2-12)$$

Equations (11) and (12) and the respective requirements on F and λ complete the formulation except for initial and boundary conditions.

In the steady-state problem of a half-space subject to a surface pressure $p(x,t)$, the latter and all expressions for stresses, velocities, etc., in the solution must be functions of

$$\xi = x - Vt \quad (2-13)$$

Equations (11), (12) may therefore be reduced to a set of partial differential equations in the two independent variables ξ and y

$$\left. \begin{aligned}
-\frac{V}{2G} \frac{\partial s_x}{\partial \xi} - \frac{V(1-2\nu)}{6(1+\nu)G} \frac{\partial J_1}{\partial \xi} + \lambda s_x &= \frac{\partial v_x}{\partial \xi} \\
-\frac{V}{2G} \frac{\partial s_y}{\partial \xi} - \frac{V(1-2\nu)}{6(1+\nu)G} \frac{\partial J_1}{\partial \xi} + \lambda s_y &= \frac{\partial v_y}{\partial \xi} \\
-\frac{V}{2G} \frac{\partial \tau}{\partial \xi} + \lambda \tau &= \frac{1}{2} \left[\frac{\partial v_x}{\partial y} + \frac{\partial v_y}{\partial \xi} \right] \\
-\frac{V}{2G} \left(\frac{\partial s_x}{\partial \xi} + \frac{\partial s_y}{\partial \xi} \right) + \frac{V(1-2\nu)}{6(1+\nu)G} \frac{\partial J_1}{\partial \xi} + \lambda (s_x + s_y) &= 0
\end{aligned} \right\} (2-14)$$

$$\left. \begin{aligned}
\frac{\partial s_x}{\partial \xi} + \frac{1}{3} \frac{\partial J_1}{\partial \xi} + \frac{\partial \tau}{\partial y} &= -\rho V \frac{\partial v_x}{\partial \xi} \\
\frac{\partial s_y}{\partial y} + \frac{1}{3} \frac{\partial J_1}{\partial y} + \frac{\partial \tau}{\partial \xi} &= -\rho V \frac{\partial v_y}{\partial \xi}
\end{aligned} \right\} (2-15)$$

In plastic regions the additional equation $F = 0$ applies, so that there are a total of seven relations for the seven unknown quantities s_x , s_y , τ , J_1 , v_x , v_y and $\lambda > 0$. In non-dissipative regions Eqs. (14), (15) apply, but the function λ vanishes identically, $\lambda \equiv 0$, while F must satisfy either $F < 0$, or the two conditions $F = 0$, $\dot{F} \leq 0$ simultaneously. In

the nondissipative case there are only six differential equations and six unknown quantities. The complete solution of the problem is to be obtained from the six differential equations (14), (15) and the applicable relations on λ and F , subject to appropriate boundary or initial conditions at the surface and at the junctions of the as yet unknown regions.

It is demonstrated in Appendix B that the system of differential equations in plastic regions is hyperbolic for the case under consideration, $V > c_p$, there being four characteristic directions which, due to the nonlinearity, are stress dependent. The problem in nondissipative regions [1] is also hyperbolic, but without the stress dependency. Without the subdivision of the domain into regions of unknown extent, e.g. in the purely elastic superseismic problem [1], uniqueness could be established by available theorems on the initial and boundary conditions required. In the present case of mixed regions of unknown extent no such general theorem is available, and the question of uniqueness of transient as well as steady-state solutions can not be answered in general. For the solution obtained here uniqueness will be demonstrated by detailed examination of all possibilities for solutions which satisfy the various conditions listed below.

1. On the surface, $y = 0$, a step pressure $p = p_0 H(Vt - x)$

normal to the surface is applied, so that, with reference to Eq. (13)

$$\sigma_Y = \begin{cases} -p_0 & \text{for } \xi \leq 0 \\ 0 & \text{for } \xi > 0 \end{cases} \quad (2-16)$$

while

$$\tau \equiv 0 \quad (2-17)$$

2. It is known from a general study of elastic-plastic wave propagation [6] that the largest characteristic velocity possible is c_p , the velocity of elastic P-waves. All stresses and velocities must therefore vanish outside the wedge formed by the negative ξ -axis and the P-front which is inclined at the angle

$$\phi_P = \pi - \sin^{-1} \left[\frac{1}{v} \sqrt{\frac{2G(1-\nu)}{\rho(1-2\nu)}} \right] \quad (2-18)$$

with the ξ -axis, Fig. 5.

3. While the character of the solution of the transient elastic-plastic problem near $\xi = y = 0$ is not known,

in the corresponding elastic problem no singularity occurs in the region of nonvanishing solutions for stresses and velocities. Subject to later confirmation that the steady-state problem permits solutions without singularities such solutions are prescribed. It is subsequently seen that they exist, and are unique.

To apply dimensional considerations new variables

$$R = \sqrt{\xi^2 + y^2} \quad (2-19)$$

$$\phi = \cot^{-1} \left(\frac{\xi}{y} \right) \quad (2-20)$$

are introduced. The differential equations and the various additional conditions which determine the solution contain only the dimensional quantities: ρ , V , G , k , p_0 and the coordinate R . However, three of these six quantities can be expressed by three others and by three nondimensional parameters. A suitable independent set of dimensional quantities, p_0 , V and R , is used, while the remaining quantities enter the problem only in the nondimensional combinations $\frac{\rho V^2}{G}$, $\frac{G}{k}$ and $\frac{p_0}{k}$. The stresses, velocities and the quantity λ in terms of functions of nondimensional variables become

$$s_i, \tau, J_1 = p_o f(\phi, v, \frac{\rho v^2}{G}, \frac{G}{k}, \frac{p_o}{k}) \quad (2-21)$$

$$v_i = Vf(\phi, \dots, \frac{p_o}{k}) \quad (2-22)$$

$$\lambda = \frac{V}{Rp_o} f(\phi, \dots, \frac{p_o}{k}) \quad (2-23)$$

The first two relations satisfy requirement 3. that stresses and velocities are not singular at $R = 0$. The quantity λ has a singularity for $R = 0$, but this is not objectionable because only its sign, not its value is of physical significance.*)

Using the new variables R, ϕ , and noting that the expressions (21), (22) are not functions of R , one finds for the derivatives in Eqs. (14), (15)

$$\frac{\partial}{\partial \xi} = - \frac{\sin \phi}{R} \frac{d}{d\phi} \quad (2-24)$$

$$\frac{\partial}{\partial y} = \frac{\cos \phi}{R} \frac{d}{d\phi} \quad (2-25)$$

In this fashion the partial differential equations (14), (15) in ξ and y become ordinary ones in the variable ϕ . Because of the manner of solution to be employed the unknowns s_x, s_y

*) In addition, as λ does not occur in the elastic case used as guide one can conjecture that it may show the same behavior in a transient problem.

and τ are replaced by three new dependent variables s_1 , s_2 and θ ,

$$s_x = s_1 \cos^2 \theta + s_2 \sin^2 \theta \quad (2-26)$$

$$s_y = s_2 \cos^2 \theta + s_1 \sin^2 \theta \quad (2-27)$$

$$\tau = (s_1 - s_2) \sin \theta \cos \theta \quad (2-28)$$

s_1 and s_2 are the two principal stress deviators while θ is the angle between the direction of s_1 and the horizontal, Fig. 4. Introducing further the angle γ between the direction of s_1 and the position vector, Fig. 4,

$$\gamma = \phi - \theta \quad (2-29)$$

the six differential equations, (14), (15) become finally

$$\begin{aligned} s_1' \cos^2 \theta + s_2' \sin^2 \theta - (s_1 - s_2) \theta' \sin 2\theta + \\ + \frac{1-2\nu}{3(1+\nu)} J_1' + L(s_1 \cos^2 \theta + s_2 \sin^2 \theta) = - \frac{2G}{V} v_x' \end{aligned} \quad (2-30)$$

$$\begin{aligned} s_1' \sin^2 \theta + s_2' \cos^2 \theta + (s_1 - s_2) \theta' \sin 2\theta + \\ + \frac{1-2\nu}{3(1+\nu)} J_1' + L(s_1 \sin^2 \theta + s_2 \cos^2 \theta) = \frac{2G}{V} v_y' \cot \phi \end{aligned} \quad (2-31)$$

$$\frac{1-2\nu}{1+\nu} J'_1 = \frac{2G}{V} (v'_y \cot \phi - v'_x) \quad (2-32)$$

$$\begin{aligned} (s'_1 - s'_2) \sin 2\theta + 2(s_1 - s_2) \theta' \cos 2\theta + L(s_1 - s_2) \sin 2\theta = \\ = \frac{2G}{V} (v'_x \cot \phi - v'_y) \end{aligned} \quad (2-33)$$

$$\begin{aligned} s'_1 \cos \theta \sin \gamma + s'_2 \sin \theta \cos \gamma - (s_1 - s_2) \theta' \cos (\gamma - \theta) + \\ + \frac{1}{3} \sin \phi J'_1 = -\rho V v'_x \sin \phi \end{aligned} \quad (2-34)$$

$$\begin{aligned} s'_1 \sin \theta \sin \gamma - s'_2 \cos \theta \cos \gamma + (s_1 - s_2) \theta' \sin (\gamma - \theta) + \\ - \frac{1}{3} \cos \phi J'_1 = -\rho V v'_y \sin \phi \end{aligned} \quad (2-35)$$

Primes indicate differentiation with respect to ϕ , and L is related to λ ,

$$L \equiv \frac{2GR}{V \sin \phi} \lambda \quad (2-36)$$

The function L is subject to the same conditions as λ , i.e., $L > 0$ in plastic regions, $L = 0$ elsewhere.

The expression for the plastic potential in these variables is

$$F = s_1^2 + s_1 s_2 + s_2^2 - k^2 \quad (2-37)$$

In plastic regions Eq. (6) requires $\dot{F} = 0$, giving the additional differential equation

$$(2s_1 + s_2) s_1' + (s_1 + 2s_2) s_2' = 0 \quad (2-38)$$

The unknowns v_x' and v_y' can be eliminated from Eqs. (30)-(38) without differentiation. Using the symbol

$$X \equiv X(\phi) = \frac{\rho V^2}{2G} \sin^2 \phi \quad (2-39)$$

the operations

$$\text{Eq. (45a)} = \text{Eq. (30)} + \text{Eq. (31)} - \text{Eq. (32)} \quad (2-40)$$

$$\text{Eq. (45b)} = -X \text{Eq. (32)} + \sin \phi \text{Eq. (34)} - \cos \phi \text{Eq. (35)} \quad (2-41)$$

$$\begin{aligned} \text{Eq. (45c)} = X \{ \sin 2\theta [\text{Eq. (31)} - \text{Eq. (30)}] + \cos 2\theta \text{Eq. (33)} \} + \\ + \cos (\gamma - \theta) \text{Eq. (34)} - \sin (\gamma - \theta) \text{Eq. (35)} \end{aligned} \quad (2-42)$$

$$\begin{aligned} \text{Eq. (45d)} = X \{ \cos 2\theta [\text{Eq. (31)} - \text{Eq. (30)}] - \sin 2\theta \text{Eq. (33)} \} + \\ + \sin (\gamma - \theta) \text{Eq. (34)} + \cos (\gamma - \theta) \text{Eq. (35)} \end{aligned} \quad (2-43)$$

$$\text{Eq. (45e)} = \text{Eq. (38)} \quad (2-44)$$

lead to the following set of five differential equations for plastic regions:

$$\begin{bmatrix}
 1 & 1 & -\left(\frac{1-2\nu}{1+\nu}\right) & 0 & 0 & (s_1 + s_2) \\
 \sin^2 \gamma & \cos^2 \gamma & 1 - 3X\left(\frac{1-2\nu}{1+\nu}\right) & -\sin 2\gamma & 0 & 0 \\
 \frac{1}{2} \sin 2\gamma & \frac{1}{2} \sin 2\gamma & \sin 2\gamma & 2X-1 & 0 & 0 \\
 \sin^2 \gamma - X & X - \cos^2 \gamma & -\cos 2\gamma & 0 & -X(s_1 - s_2) & (s_1 - s_2)\theta' \\
 2s_1 + s_2 & s_1 + 2s_2 & 0 & 0 & 0 & L
 \end{bmatrix}
 \begin{bmatrix}
 s'_1 \\
 s'_2 \\
 \frac{1}{3} J'_1 \\
 (s_1 - s_2)\theta' \\
 L
 \end{bmatrix}
 = 0$$

(2-45)

The system of equations for elastic regions consists of

the first four Eqs. (45) without the terms containing L, i.e.,

$$\begin{bmatrix}
 -1 & -1 & \frac{1-2\nu}{1+\nu} & 0 & 0 \\
 \sin^2 \gamma & \cos^2 \gamma & 1 - 3X\frac{1-2\nu}{1+\nu} & -\sin 2\gamma & 0 \\
 \sin 2\gamma & \sin 2\gamma & 2 \sin 2\gamma & -2(1-2X) & 0 \\
 \sin^2 \gamma - X & X - \cos^2 \gamma & -\cos 2\gamma & 0 & 0
 \end{bmatrix}
 \begin{bmatrix}
 s'_1 \\
 s'_2 \\
 \frac{1}{3} J'_1 \\
 (s_1 - s_2)\theta'
 \end{bmatrix}
 = 0$$

(2-46)

3. SOLUTIONS FOR INDIVIDUAL REGIONS.

As a first step towards the construction of overall solutions, expressions for individual regions must be derived. The latter will be combined in Section 4 to find the solution for the entire domain.

a) Nondissipative Regions.

Equations (2-46) are linear and homogeneous so that the derivatives of the stresses s'_1 , s'_2 , J'_1 and the value $(s_1 - s_2)\theta'$ vanish, unless the coefficient matrix in Eqs. (2-46) is singular, requiring

$$X(1 - 2X) [1 + (1 - 2X)(1 - 2\nu)] = 0 \quad (3-1)$$

Equation (1) has two significant roots,

$$X_P = \frac{1 - \nu}{1 - 2\nu} \quad (3-2)$$

and

$$X_S = \frac{1}{2} \quad (3-3)$$

and a spurious one, $X = 0^*$). Substitution of the two roots X_P and X_S into (2-39) furnishes the two locations

$$\phi_P = \pi - \sin^{-1} \frac{c_P}{V} \quad (3-4)$$

$$\phi_S = \pi - \sin^{-1} \frac{c_S}{V} \quad (3-5)$$

where c_P , c_S are the velocities of P- and S-waves, respectively. In all locations $\phi \neq \phi_P$ or ϕ_S the values s'_1 , s'_2 , J'_1 , $(s_1 - s_2)\theta'$ vanish, so that in nondissipative regions the stresses must remain constant except at the locations ϕ_P and ϕ_S . The latter being the potential locations of elastic P- and S-shock fronts, respectively, it is known that discontinuities in stresses and velocities may occur at these locations and may, therefore, be part of the complete solutions to be constructed. The following pertinent details will be required subsequently.

(1) The P-front.

Designating the discontinuous changes in the various quantities at the front by the symbol Δ , the discontinuities in the stresses σ_N , $\sigma_T = \sigma_Z$ (normal and tangential to the front, respectively) and in the component

*)

It is due to multiplication by $\sin \phi$ in changing variables and eliminating the velocities.

v_N of the velocity (normal to the front) are proportional to $\Delta\sigma_N$.

$$\Delta\sigma_T = \frac{\nu}{1-\nu} \Delta\sigma_N, \Delta v_N = -\frac{\Delta\sigma_N}{\rho c_P} \quad (3-6)$$

No other discontinuities can occur in this location.

The changes $\Delta\sigma_N$ and $\Delta\sigma_T$ are of course limited by the yield condition $F \leq 0$ which must be satisfied on either side of the front.

In the actual solution a P-front will be encountered only for the special case where the region ahead of the front is stressless and at rest. The normal to the front is then a principal direction for the stresses behind the front, so that $\gamma = 0$ or $\frac{\pi}{2}$. Selecting $\sigma_1 \equiv \sigma_N$, corresponds to

$$\gamma = \frac{\pi}{2} \quad (3-7)$$

The value of the other quantities of interest behind the shock front are

$$\beta = 3, s_1 = \frac{2(1-2\nu)\sigma_1}{3(1-\nu)}, s_2 = -\frac{(1-2\nu)\sigma_1}{3(1-\nu)}, J_1 = \frac{(1+\nu)\sigma_1}{1-\nu} \quad (3-8)$$

subject to the limitation

$$|\sigma_1| \leq \frac{\sqrt{3}(1-\nu)k}{1-2\nu} \quad (3-9)$$

imposed by the yield condition.

(2) The S-front.

At an S-front discontinuities occur only in the shear stress $\tau_N = \tau_T = \tau$ and in the tangential velocity v_T . The change in velocity is proportional to $\Delta\tau$.

$$\Delta v_T = \frac{\Delta\tau}{\rho c_S} \quad (3-10)$$

In addition, the yield condition $F \leq 0$ must again be satisfied ahead of and behind the front.

The relations between the state of stress on either side of an S-front in terms of $\Delta\tau$ and of the variables s_1 , s_2 , β and γ can be obtained in such routine manner that only one result actually used in Section 4 is presented here.

It is possible for an S-front to occur between two neutral regions, i.e. regions of constant stress for both of which the yield condition, $F = 0$, is satisfied. In this special case the quantities β , J_1 , s_1 and s_2 have no discontinuity at the front, only the direction of the principal stress changes. The values of the angles $\bar{\gamma}$, $\bar{\gamma}$ ahead of and behind the front, respectively, are comple-

mentary

$$\bar{\gamma} = \pi - \bar{\gamma} \quad (3-11)$$

as shown in Fig. 6 .

b) Plastic Regions.

In such regions Eqs. (2-45) apply. They are linear and homogeneous in the values s'_1 , s'_2 , etc., and may be satisfied by

$$s'_1 = s'_2 = J'_1 = (s_1 - s_2)\theta' = L = 0 \quad (3-12)$$

However, $L = 0$ implies $\lambda = 0$ which violates Eq. (2-9). It follows that in plastic regions the determinant of Eqs. (2-45) must vanish, giving the "determinantal equation"

$$(s_1 + s_2)^2 (b_2^2 + b_1 b_3) = 0 \quad (3-13)$$

where

$$b_1 = 2 [1 + (1-2\nu)(1-2X)] \quad (3-14)$$

$$b_2 = \beta \cos 2\gamma + (1-2X)(1-2\nu) \quad (3-15)$$

$$b_3 = (1+v)(1-2X) - \beta^2 X \quad (3-16)$$

and

$$\beta = \frac{s_1 - s_2}{s_1 + s_2} \quad (3-17)$$

If Eqs. (14) to (17) are substituted into Eq. (13) it is seen that the latter is a homogeneous quadratic expression in s_i

Due to the vanishing of the determinant only four of the five Eqs. (2-45) are independent. By definition L must not vanish, so that s'_1 , s'_2 , J'_1 and θ' can always be expressed in terms of L ,

$$s'_1 = \frac{(3-\beta) b_4 (s_1 + s_2) L}{3b_2} \quad (3-18)$$

$$s'_2 = -\frac{(3+\beta) b_4 (s_1 + s_2) L}{3b_2} \quad (3-19)$$

$$\theta' = \frac{+ \sin 2\gamma b_3 L}{\beta(1-2X) b_2} \quad (3-20)$$

$$J'_1 = \frac{3(1+v)}{(1-2v)} \left[b_2 - \frac{2}{3} \beta b_4 \right] \frac{(s_1 + s_2) L}{b_2} \quad (3-21)$$

Velocities and accelerations may be obtained from the relations

$$v'_x = \frac{-V \sin \phi (s_1 + s_2)L}{2G(1-2X) b_2} [b_2 \beta \sin(2\gamma - \phi) - 2b_3 \sin \phi] \quad (3-22)$$

$$v'_y = \frac{-V \sin \phi (s_1 + s_2)L}{2G(1-2X) b_2} [b_2 \beta \cos(2\gamma - \phi) + 2b_3 \cos \phi] \quad (3-23)$$

$$\dot{v}_x = \frac{v}{R} \sin \phi v'_x \quad (3-24)$$

$$\dot{v}_y = \frac{v}{R} \sin \phi v'_y \quad (3-25)$$

where

$$b_4 = (1+v) \cos 2\gamma + \beta X(1-2v) \quad (3-26)$$

Since Eq. (13) must remain valid throughout a plastic region, it may be differentiated with respect to ϕ . This leads to an expression which contains the first derivatives of the stresses linearly, so that substitution of Eqs. (18)-(20) furnishes a linear equation for L. Its solution gives L as a function of β , γ and of the position angle ϕ ,

$$L = \frac{3b_2(1-2X)}{4 \sin^2 \phi} \left\{ \frac{X \sin 2\phi [4(1-2v)(b_2 + b_3) + b_1(\beta^2 + 2 + 2v)] + 4b_2 \beta \sin 2\gamma \sin^2 \phi}{(3 + \beta^2)(1-2X)b_4(b_2 \cos 2\gamma - b_1 \beta X) + 3b_2 b_3 \sin^2 2\gamma} \right\} \quad (3-27)$$

The values of the derivatives s'_1 , s'_2 , J'_1 and θ' can be obtained by substitution of Eq. (27) into Eqs. (18)-(21).

In principle Eqs. (18)-(27) permit the numerical determination of the values of stresses and velocities in the interior of a plastic region by quadratures if the values on one boundary of this region are known. The starting values must inherently satisfy the yield condition, $F = 0$, and the determinantal equation (13). Further, the condition

$$L > 0 \quad (3-28)$$

must be satisfied, to assure that the result applies.

c) Discontinuities (Shock Fronts).

It is known that in transient problems one, but just one type of plastic shock front can propagate in the elastic-plastic material considered here [6]. However, such a front can exist only in locations where the normal to the front lies in the direction of one of the principal stresses, while the other two are equal, and where the yield condition is satisfied. The velocity of propagation of the front is

$$\bar{c} = \sqrt{\frac{K}{\rho}} \quad (3-29)$$

where $K = \frac{2(1+\nu)}{3(1-2\nu)} G$ is the bulk modulus. The discontinuity is restricted to the particle velocity v_N normal to the front and to the first invariant J_1 . The change ΔJ_1 must have the same sign as J_1

$$\frac{\Delta J_1}{J_1} > 0 \quad (3-30)$$

The other conditions stated define the values of γ and β

$$\gamma = \frac{\pi}{2}, \quad \beta = 3 \quad (3-31)$$

A discontinuity traveling in real space with velocity \bar{c} , Eq. (29), can occur in the steady state problem only in the location

$$\bar{\phi} = \pi - \sin^{-1} \left(\frac{\bar{c}}{\bar{V}} \right) \quad (3-32)$$

The corresponding value of X is

$$\bar{X} = \frac{1+\nu}{3(1-2\nu)} \quad (3-33)$$

The denominator in Eq. (27) vanishes, as expected, for these values of γ , β and X .

The possibility of the occurrence of this discontinuity

(shock) must be considered when constructing the complete solutions in Section 4. It was actually found that no such shocks occur, except in the limit, $v \rightarrow \infty$. However, for large values of the parameter $\frac{p_0}{k}$ defining the surface load, the solutions come extremely close to the singular values representing a shock, so that computing difficulties occur.

d) Asymptotic Solutions near Singularities.

As stated in the previous paragraph, numerical difficulties in the vicinity of $\phi = \bar{\phi}$ will make the procedure for integration of Eqs. (2-45) outlined in subsection b unsuitable and inapplicable if the values of β and γ are sufficiently close to those for a plastic front, $\beta = 3$, $\gamma = \frac{\pi}{2}$. To establish the behavior of the solution of Eqs. (2-45) in such cases, let

$$\begin{aligned}\gamma &= \frac{\pi}{2} + \eta \\ \beta &= 3 + \Delta \\ \phi &= \bar{\phi} + \epsilon\end{aligned}\tag{3-34}$$

where η , Δ and ϵ are small quantities. Introducing these expressions into the determinantal equation and into the differential equation (20) for θ' , retaining only the leading terms in each of the new variables, one obtains for $v \neq \frac{1}{8}$

$$\Delta^2 - a_1 \eta^2 = - a_2 \epsilon \quad (3-35)$$

$$\frac{d\eta}{d\epsilon} = 1 + a_4 \eta L \quad (3-36)$$

Combination of Eqs. (17), (18) and (19) permits the formulation of a relation for $\frac{d\Delta}{d\epsilon} \equiv \beta'$,

$$\frac{d\Delta}{d\epsilon} = (a_3 \eta^2 - \Delta) L \quad (3-37)$$

These three equations govern the solution in terms of the three unknowns η , Δ and L . The derivative of J_1 becomes

$$\frac{dJ_1}{d\epsilon} = \frac{6(1+\nu) kL}{(1-2\nu) \sqrt{3 + (3 + \Delta)^2}} \quad (3-38)$$

while s_1 and s_2 can be found from the yield condition and from Eq. (34) once Δ is known. A solution of the above equations is valid only if the inequality (28), $L > 0$, is satisfied.

The coefficients a_i are

$$a_1 = \frac{288(1+\nu)}{1-8\nu}$$

$$a_2 = \frac{48(1+\nu)}{1-2\nu} \sqrt{\frac{3(1-\nu)\nu^2}{(1+\nu) c_p^2} - 1}$$

(3-39)

$$a_3 = \frac{6(5-4\nu)}{1-8\nu}$$

$$a_4 = \frac{2(1+\nu)}{1-8\nu}$$

The terms $(1-8\nu)$ in the denominator of several coefficients necessitate exclusion of the case $\nu = 1/8$.

The three asymptotic equations (35-37) are nonlinear and do not have closed solutions^{*)}. Numerical integration near $\epsilon = \Delta = \eta = 0$ would again encounter difficulties because of the presence of the same type of singularity which occurs in the original differential equations. However, Appendix A shows that simple expressions exist which describe the asymptotic behavior of the solution of Eqs. (35-37) near $\epsilon = \Delta = \eta = 0$. These equations being asymptotic approximations for the original differential equations, the behavior of the solutions

*)

By elimination of L and Δ one can find, as alternative to Eqs. (35)-(37), a first order differential equation

$$\eta' = \frac{c_1 \eta - \epsilon}{c_2 \eta^2 - \epsilon} \quad (3-40)$$

$$\text{where } c_1 = \frac{a_4}{2}, \quad c_2 = \frac{a_1(1+a_4)}{a_2} \quad (3-41)$$

valid provided $a_4 \neq -1$ (i.e. $\nu \neq 1/2$).

of the latter is also described by the results obtained in Appendix A. It is shown that Eqs. (35-37) for $\nu \neq 1/8$ have limiting solutions consisting of separate branches. Because the signs of several of the coefficients a_i differ for $\nu \geq 1/8$, the two cases have different character.

$1/2 > \nu > 1/8$. In this case solutions exist only for $\epsilon \leq 0$, which is due to the character of Eq. (35). Noting $a_1 < 0$, $a_2 > 0$, the left hand side of the latter is a sum of squares and therefore positive and no real solutions Δ , η can exist for $\epsilon > 0$.

Two types of limiting solutions exist, given by Eqs. (A-3,4,7) and Eqs. (A-8,9,14), respectively.

In solutions of Type 1, η is proportional to $\sqrt{-\epsilon}$, while Δ , which is proportional to ϵ , is much smaller than η , so that approximately $\Delta \approx 0$. The reverse applies for solutions of Type 2, where Δ is proportional to $\sqrt{-\epsilon}$ and $\eta \approx 0$. The sign of the square roots is arbitrary, so that in each case the solution for the respective quantity has two branches.

Whenever the numerical integration of the original differential equations, (2-45), approaches $\phi = \bar{\phi}$, the values η and Δ must approach one of the asymptotic solutions. In Section 5a, where numerical cases are discussed, the actual and the asymptotic solutions for Δ are shown in Fig. 15 for

a typical case where $\nu > 1/8$. The values of the stress deviators s_i being defined by $\beta = 3 + \Delta$, and Δ being a small quantity, s_1 and s_2 at the terminal point of the integration (i.e. at the end of the plastic region) must have a value close to that for $\beta = 3$, viz.

$$s_1 \sim \mp \frac{2\sqrt{3}k}{3} \qquad s_2 \sim \pm \frac{\sqrt{3}k}{3} \qquad (3-42)$$

The signs in these expressions depend on the branch used in approaching $\phi \rightarrow \bar{\phi}$. The value of J_1 is to be determined from Eq. (38). Regardless of the type of solution, Eqs. (A-4) and (A-9) indicate that L , and therefore J_1' , are proportional to $\frac{1}{\epsilon}$. As the terminal point of the integration moves closer to $\epsilon = 0$, the integral of J_1' , i.e. the value J_1 , increases without upper bound. While s_i , θ and γ are practically constant near the singularity, a very large change in J_1 occurs in a very small angular region. The magnitude of this change depends on the stopping point, i.e. on the end of the plastic region. In a plastic shock J_1 is discontinuous, while s_i , θ and γ remain constant and the solution described above is quite similar to such a shock, except that the change in J_1 occurs in a small, but finite region of ϕ . The solution describes, therefore, a "plastic shock" of finite thickness.

$0 < \underline{v} < 1/8$. In this case $a_1 > 0$, so that Eq. (35) permits solutions without restriction on ϵ . A plastic region may therefore contain the point $\phi = \bar{\phi}$. It is shown in Appendix A that for $\epsilon > 0$ solutions of Type 1 apply, Eqs. (A-3,4,7), where η is proportional to $\sqrt{\epsilon}$, while $\Delta \ll \eta$ is linear in ϵ . For $\epsilon < 0$ the solution is of Type 2, Δ being proportional to $\sqrt{-\epsilon}$, while $\eta \ll \Delta$ is linear in ϵ . A solution which extends continuously to both sides of $\phi = \bar{\phi}$ must therefore follow first the one, then the other type of limiting solution. However, the two are not continuous in the derivatives, so that an actual solution cannot follow either one asymptotically to the origin $\epsilon = 0$ as was the case for $v > 1/8$. An actual solution must have a smooth transition, contained in Eqs. (35-37), but lost in Appendix A due to the approximations required. Figures 17 and 18, presented in Section 5a in connection with typical numerical results, show the actual and the asymptotic solutions.

The details of the transition could be obtained by numerical integration of Eqs. (35-37). Even without such integration, one can already state qualitatively that, just as for $v > 1/8$, the quantities s_1, θ, γ will undergo only minor changes near $\phi = \bar{\phi}$. The value J_1 , however, will change radically, it becomes larger without bound, when the solution passes closer to the point $\eta = \Delta = \epsilon = 0$. Again, the actual

solution in the vicinity of the singularity may be said to be a plastic shock of finite thickness.

When the asymptotic solutions were obtained it was expected that the numerical integration of the original differential equations could be carried sufficiently close to the singularity, so that the range of validity of the two solutions overlaps. Due to the very severe singularity this expectation was not born out by the facts. To obtain a satisfactory overlap of solutions, approximate equations, similar to Eqs. (35-37), but retaining higher order terms, were formed, and integrated numerically. The details are given in [8]. While the solutions in closed form obtained in Appendix A give a good qualitative understanding of the shock front of finite thickness described above, they are not sufficient to find quantitative results, which can be obtained from the analysis in [8]. For this reason, combined with the complexity of the refined equations required for the special case $\nu = 1/8$, no attempt was made to find an asymptotic solution for this case in closed form.

An important conclusion which may be drawn from the character of the asymptotic solutions concerns the question whether a plastic shock may occur in the interior, or at the boundary of a plastic region. If this would occur the change in value of J_1 in an interval including the shock location $\bar{\phi}$ would be infinite, because the integral of $\frac{dJ_1}{d\epsilon}$ is divergent at the

point $\Delta \equiv \eta \equiv \epsilon \equiv 0$. This of course can not occur in an actual case where the surface load $\frac{p_0}{k}$ is finite, so that only the possibility of a shock front between nondissipative regions is to be considered in the construction of solutions.

4. CONSTRUCTION OF SOLUTIONS.

In Section 3 a number of partial solutions were obtained from which the solution of the complete boundary value problem is now to be constructed. Section 3b gives the differential equations for the determination of the stresses and velocities in plastic regions; Section 3a indicates that all unknowns in nondissipative regions are constants, except for discontinuities of a prescribed nature at the locations ϕ_S and ϕ_P . In addition, as discussed in Section 3c, a shock front with plastic deformation may occur at the location $\bar{\phi}$.

In Section 2 boundary conditions, and additional requirements, which the solution must satisfy, were formulated and discussed. Equations (2-16 and 17) for the prescribed surface load in terms of the variables s_i , J_1 , γ and ϕ require either

$$s_1(\pi) + \frac{J_1(\pi)}{3} = -p_0, \quad \theta(\pi) = \frac{\pi}{2} \quad (4-1a)$$

or

$$s_2(\pi) + \frac{J_1(\pi)}{3} = -p_0, \quad \theta(\pi) = 0 \quad (4-1b)$$

A further boundary condition requires that all quantities

must vanish for $\phi < \phi_P$, Eq. (2-18). This condition, in conjunction with the fact that a plastic region or a plastic shock can exist only in locations where the yield condition is satisfied, permits the conclusion that the change in stress from vanishing values for $\phi < \phi_P$ to nonvanishing values must be nondissipative. However, in nondissipative regions the stresses are constant, except for discontinuities at $\phi = \phi_P$ or $\phi = \phi_S$. A solution in which plastic deformations occur at all can therefore start only in one of the two ways described below.

Case 1. Discontinuities occur at the P- and S-fronts, where the discontinuity at ϕ_P satisfies the inequality

$$\sigma_1 \left[\phi_P^{(+)} \right] < \frac{\sqrt{3}(1-\nu)k}{1-2\nu} \quad (4-2)$$

while the discontinuity $\Delta\tau$ at ϕ_S is of such magnitude that the yield condition

$$F \left[\phi_S^{(+)} \right] = 0 \quad (4-3)$$

is satisfied. The symbols (+) or (-) indicate approach from above or below, respectively.

Case 2. A discontinuity occurs at the P-front, described by Eqs. (3-7,8), so that the yield condition is satisfied for $\phi = \phi_P^{(+)}$, i.e.

$$\sigma_1 \left[\phi_P^{(+)} \right] = \frac{\sqrt{3(1-\nu)k}}{1-2\nu} \quad (4-4)$$

In Case 1, plasticity may occur only in locations $\phi > \phi_S$, while, in Case 2 it may occur already for $\phi_P < \phi < \phi_S$.

As a next step in the search for solutions it is helpful to consider the latter as function of the nondimensional surface pressure $\frac{p_0}{k}$, while Poisson's ratio ν and the velocity V are considered constant. For sufficiently small values of $\frac{p_0}{k}$ the solution must be entirely elastic, but as $\frac{p_0}{k}$ increases plastic regions must occur and should form a gradually changing pattern. Based on [1] one can find the limiting value $\frac{p_E}{k}$, above which entirely elastic solutions are no longer possible.

The elastic solution, shown in Fig. 7, has two discontinuities at ϕ_P and ϕ_S with regions of constant stress between ϕ_P and ϕ_S and between ϕ_S and the loaded surface $\psi = \pi$. Depending on the values of the parameters ν and $\frac{V}{c_p}$ the yield condition may be reached in either of the two regions resulting in different expressions for $\frac{p_E}{k}$. If the region

$\phi > \phi_S$ controls,

$$\frac{P_E}{k} = \left[\frac{3N^2}{3N^2 - 3N \cos 2\phi_S + (1-v+v^2) \cos^2 2\phi_S} \right]^{\frac{1}{2}} \quad (4-5a)$$

where

$$N = \frac{1}{2} \left[\cos 2\phi_S + (1-2v) \cos 2(\phi_S - \phi_F) \right] \quad (4-5b)$$

while

$$\frac{P_E}{k} = \left[\frac{3N^2}{(1-2v)^2 \cos^2 2\phi_S} \right]^{\frac{1}{2}} \quad (4-6)$$

if the region $\phi < \phi_S$ controls. The decision which region controls can be made by comparing the values given by Eqs. (5) and (6), the smaller one controlling. Designating as Range I the combination of values v and $\frac{V}{c_P}$ where Eq. (5a) controls, one finds that in this range

$$\left(\frac{V}{c_P} \right)^2 > \frac{(1-2v)^2}{(1-v)(1-3v)} \quad (4-7)$$

The remainder of the range will be designated as Range II.

Both ranges are shown in Fig. 8. The limiting values $\frac{p_E}{k}$ are shown in Fig. 9 for several values of ν as function of $\frac{V}{c_p}$.

If the surface load exceeds the value $\frac{p_E}{k}$ by a sufficiently small amount the elastic-plastic solution should differ only slightly from the elastic one, which can be used to predict the character of the solution. Because the situations differ, the Ranges I and II must be discussed separately.

a) Solutions in Range I.

In this case $\frac{p_E}{k}$ is given by Eq. (5a) and the yield stress in the elastic solution is reached only in the region $\phi > \phi_S$. The discontinuity σ_1 satisfies then the inequality (2) and continuity requires that this inequality will still apply for a range of values $\frac{p_L}{k} > \frac{p_O}{k} > \frac{p_E}{k}$, where p_L is a limiting value, not yet known. In this range the start of the solutions will be according to Case 1 and plasticity can therefore occur only in the region $\phi > \phi_S$.

Using an indirect approach, the determination of plastic solutions for values $\frac{p_O}{k} < \frac{p_L}{k}$ begins with the selection of a pair of starting values σ_1 and $\Delta\tau$ near those for the limiting elastic case. Experience and continuity considerations indicate that the value $|\sigma_1|$ should be larger than $|\sigma_1|$ corresponding to p_E given by Eq. (5a). A plastic region can

start only at a point ϕ_1 which is a root of Eq. (3-13). Inequalities derived in Appendix B, Eq. (B-23) indicate that this equation has one, but only one root $\phi_1 > \phi_S$. Starting integration at $\phi = \phi_1$ the solution in the interior of the plastic region is determined from Eqs. (3-18 to 27). The plastic region can be extended as long as Eq. (3-27) gives values $L > 0$, but the plastic region may be terminated at will at any earlier location ϕ_2 . The solution for $\phi > \phi_2$ is then nondissipative, i.e. all quantities are constant. If, therefore, in the process of forward integration a value θ is encountered which satisfies Eq. (1), the plastic region is terminated and a solution for one value of the surface pressure $\frac{p_0}{k}$ has been obtained. Repeating this process with gradually increasing starting values $|\sigma_1|$ the whole spectrum of values satisfying the inequality (2) can be explored. Solutions, if any, obtained in this manner will have the configuration shown in Fig. 10, i.e. discontinuities at ϕ_p and ϕ_S and a plastic region $\pi > \phi_2 > \phi_1 > \phi_S$. There will be an elastic region of constant stress from ϕ_p to ϕ_S and two neutral regions to either side of the plastic one.

Postponing the discussion of uniqueness and of alternative configurations, one can proceed in a similar manner when the solution begins at $\phi = \phi_p$ as indicated in Case 2. Starting with a value σ_1 according to Eq. (3), the yield condition is

satisfied for any value $\phi > \phi_p$, so that the determinantal equation (3-13) according to Eq. (B-23) now has two roots, $\phi_1 \geq \phi_s$, at which plastic regions may start. Both roots must be explored. If the larger one, $\phi_1 > \phi_s$, leads to a solution, it has a configuration as shown in Fig. 11a. Starting, alternatively, with the smaller root, $\phi_p < \phi_1 < \phi_s$, several possibilities are to be investigated. The integration may be continued as long as $L > 0$ to see if a value $\theta = 0$ or $\frac{\pi}{2}$ can be reached. The configuration of such a solution, if any, is shown in Fig. 11b. Alternatively, the plastic region can be terminated at will at a point $\phi_2 < \phi_s$ where $\theta \neq 0, \frac{\pi}{2}$. The plastic region will then be followed by a neutral one for values $\phi > \phi_2$. The inequalities on the roots of Eq. (3-13) indicate that there is just one more root $\phi_3 > \phi_s$, when a second plastic region can begin. Starting integration at this point may lead to a terminal location ϕ_4 , where $\theta = 0$ or $\frac{\pi}{2}$. The configuration of such a solution, if any, Fig. 11c, contains a P-front and two plastic regions, separated by three neutral regions. There are, however, further possibilities. The neutral region $\phi > \phi_2$ which follows the first plastic one may be terminated at ϕ_s by an elastic change in shear, $\Delta\tau$, which is restricted in sign and intensity by the yield condition. If $\Delta\tau$ is such that $F[\phi_s^{(+)}] < 0$, the region $\phi > \phi_s$ becomes elastic. This might permit values $\theta = 0, \frac{\pi}{2}$.

at the surface, the corresponding solution having the configuration of Fig. 12. Finally, the important case must be considered where the value of $\Delta\tau$ is such that $F\left[\phi_S^{(+)}\right]$ vanishes again, a situation discussed in Section 3-a-2. In the latter case there is again a neutral region for $\phi > \phi_S$, which can be followed by a plastic region because Eq. (3-13) has a root $\phi_3 > \phi_S$ giving a starting location. The configuration of a solution obtained in this manner is shown in Fig. 13.

b) Solutions in Range II.

In this range $\frac{P_E}{k}$ is given by Eq. (6) so that in the limiting case $\frac{P_O}{k} = \frac{P_E}{k}$ yield is just reached in the region $\phi_P < \phi < \phi_S$. The discontinuity σ_1 at the P-front must therefore satisfy Eq. (4), which will also hold for neighboring elastic-plastic solutions where $\frac{P_O}{k}$ exceeds $\frac{P_E}{k}$ slightly. These solutions will therefore start at $\phi = \phi_P$ according to Case 2. In the limiting solution for $\frac{P_O}{k} = \frac{P_E}{k}$ the region $\phi > \phi_S$ is below yield and continuity requires this to hold in neighboring elastic-plastic solutions, so that the plastic region must lie in the range $\phi_P < \phi_1 < \phi_2 < \phi_S$. The construction of solutions, Fig. 12, begins exactly as for $\frac{P_O}{k} > \frac{P_L}{k}$. For each terminal point ϕ_2 the strength of the discontinuity $\Delta\tau$ at the shear front is determined by the requirement that $\theta = 0$ or $\frac{\pi}{2}$ subject to the limitation $F\left[\phi_S^{(+)}\right] \leq 0$. When

the required value $\Delta\tau$ violates this condition a second plastic region for $\phi > \phi_S$ is needed, i.e. the configurations shown in Figs. 11c and 13 are to be investigated.

c) Alternative Solutions, and Considerations of Uniqueness and Existence.

In the absence of a uniqueness theorem it is vital to demonstrate that configurations other than those shown in Figs. 10 to 13 can not lead to solutions. It has been shown in Appendix B that Eq. (3-13), which is also the equation for the characteristic directions, has for a given state of stress one root ϕ , no more no less, in each of the intervals $\phi_P < \phi < \phi_S$ and $\phi_S < \phi < \pi$. If a plastic region ends at a location ϕ_i in one of these intervals, the state of stress in the remainder of the interval $\phi > \phi_i$ is necessarily neutral and uniform, and equal to the one at the terminal point ϕ_i of the plastic region. ϕ_i is therefore the only solution of Eq. (3-13) for this state of stress in the particular interval, and no more than one plastic zone can therefore occur in any interval.

In Section 3-c the possibility of discontinuous plastic shock fronts has been indicated and their occurrence must be considered. First, it has been concluded at the end of Section 3-d that a plastic shock can not occur in the interior of a

plastic region nor at its end, so that a plastic shock, if it occurs, must lie between nondissipative regions and be quite separate from a continuous plastic region. Further, such fronts can not occur in an interval $\phi_P < \phi < \phi_S$ or $\phi_S < \phi < \pi$ where a plastic zone occurs, because Eq. (3-13) which is satisfied in the location of a plastic shock would then have two roots in the same interval. This reasoning leaves only the possibility of configurations similar to Figs. 10 to 13, where one of the plastic zones is replaced by a plastic shock. For $v > 1/8$, where $\bar{\phi} < \phi_S$, this can not occur (except in the limit $v \rightarrow \infty$ *) because Eq. (3-31) requires that the principal stress be normal to the shock front $\bar{\phi}$, while the actual principal stress in the neutral region behind the P-front is normal to the latter. For $v < 1/8$, $\bar{\phi} > \phi_S$, so that configurations similar to Figs. 10 to 13 might occur where the plastic region degenerates into a shock at $\bar{\phi} > \phi_S$. This can not happen, however, because the direction of the principal stress behind the shock front, at $\phi > \bar{\phi}^{(+)}$, would have to be normal to this front, which contradicts the requirement $\theta = 0$ or $\frac{\pi}{2}$, on the surface, except in the limiting case $v = \infty$. Discontinuous shock fronts can therefore not occur at all for finite values of the velocity V , but values of γ and β where the conditions (3-31)

*)

In this case the surface pressure is applied simultaneously everywhere on the surface, producing the trivial result of a P-wave followed by a plastic shock, both having horizontal plane fronts.

are nearly satisfied are encountered. The asymptotic behavior of the solution near $\phi = \bar{\phi}$ in such cases was studied in Section 3-d, and examples are given in Section 5.

The preceding discussion shows that for finite values of V no plastic shock front can occur and that there can be no more than one plastic region in each of the intervals $\phi_P < \phi < \phi_S$, $\phi_S < \phi < \pi$. Combined with elastic discontinuities at the P- and S-fronts, only the limited number of configurations shown in Figs. 10 to 13 are possible.

The numerical analysis by digital computer was set up to investigate all possible alternatives, i.e. the configuration according to Fig. 10 if the starting value σ_1 satisfies Eq. (2) and any of the alternatives shown in Figs. 11 to 13 if σ_1 satisfies Eq. (3). While none of the configurations shown in Figs. 11 a-c ever furnished a solution, no general proof permitting elimination of these cases is available.

In Range I solutions which start according to Case 1, have the configuration of Fig. 10. For fixed values of ν and V , these solutions form a family which depends on one parameter, the selected starting value $|\sigma_1| > |\sigma_{1E}|$. It was found that the surface load $\frac{P_O}{K}$ increases monotonically with $|\sigma_1|$ until the limit, Eq. (4) for σ_1 is reached, which leads to a limiting value of the surface load $\frac{P_L}{K}$. However, no analytical proof of the monotonic increase of $\frac{P_O}{K}$ is available.

The solutions found for Range I, which start according to Case 2, had always the configuration shown in Fig. 13. These solutions also depend on one parameter, viz. the stopping point ϕ_2 of the plastic region between ϕ_P and ϕ_S . If ϕ_2 is selected only slightly larger than ϕ_1 , the solution must obviously be very close to the limiting one for Case 1, so that in such a case $\frac{P_O}{k} \sim \frac{P_L}{k}$ and there is a smooth transition from the configuration according to Fig. 10 to that of Fig. 13. The numerical analysis indicated that the surface load $\frac{P_O}{k}$ increases monotonically with ϕ_2 . As ϕ_2 approaches a limiting value the surface load goes to the limit $\frac{P_O}{k} \rightarrow \infty$, for reasons explained in Section 3-d.

In Range II, only solutions which start according to Case 2 were found, their configurations being as shown in Figs. 12 and 13. Figure 12 applied for values $\frac{P_E}{k} < \frac{P_O}{k} < \frac{P_L}{k}$ where $\frac{P_L}{k}$ is a bound. The corresponding family of solutions depends on the stopping point ϕ_2 of the plastic region. The bound $\frac{P_L}{k}$ is reached when the elastic region for $\phi > \phi_S$ becomes neutral. For larger values of $\frac{P_O}{k}$ Fig. 13 applies and all statements made in Range I for this case apply.

In Range I as well as in Range II, combination of all solutions obtained numerically furnished one, and only one solution for each value of $\frac{P_O}{k} > \frac{P_E}{k}$. However, no general proof is available that this must be so. Existence and

1
3

uniqueness of the solutions obtained must therefore be demonstrated for each combination of values ν and $\frac{V}{c_p}$ by actual computation of the families of solution according to the configurations shown in Figs. 10 to 13.

5. RESULTS AND CONCLUSIONS.

a) Discussion of Typical Numerical Results

The numerical integration of the simultaneous differential equations (3-18 to 21) in plastic regions was accomplished by a Runge-Kutta forward integration scheme of fourth order [9]. Computations were programmed in Fortran II for an IBM 7090 digital computer. Only typical results representing the various configurations will be given here for the case of the velocity $V = 1.25 c_p$ for several values of $\frac{p_o}{k}$ and ν . An extensive tabulation of additional results is given elsewhere, [8]. Significant differences in the solution for large values occur, depending on whether $\nu \gtrsim 1/8$, so that examples for both situations are presented.

For $\nu = 1/4$, $V = 1.25 c_p$ the limiting value $\frac{p_o}{k}$ up to which the solution is entirely elastic is $\frac{p_E}{k} = 2.50$. Figure 14a shows the detail of a solution for a slightly higher value of the pressure, $\frac{p_o}{k} = 2.61 > \frac{p_E}{k}$. The configuration has one plastic region in agreement with Fig. 10. The limiting value for this configuration is $\frac{p_L}{k} = 2.65$. When the surface pressure exceeds this value, the configuration contains two plastic zones and is of the type shown in Fig. 13. The details for the value $\frac{p_o}{k} = 3.58$ are shown in Fig. 14b. Further solutions for other values of $\frac{p_o}{k}$ can be obtained by varying the end point

ϕ_2 of the lower plastic region.

However, computational difficulties arise when the end point ϕ_2 approaches the value $\bar{\phi}$, which has in the present example the value $\bar{\phi} = 143.3957^\circ$. As explained in Section 3-d a very rapid change occurs in the quantity J_1 , nearly a shock front, when $\phi_2 \rightarrow \bar{\phi}$, with the result that the corresponding surface pressure will be large. Figure 15 illustrates the result of the measures taken to obtain numerical results in this range. First the program for the numerical integration was revised for double accuracy (16 digits). When it was found that this was not adequate to continue solutions sufficiently close to $\phi = \bar{\phi}$ to obtain agreement with the asymptotic solutions, expansions including higher order terms than used in Appendix A were made and the resulting approximate^{*)} differential equations were integrated numerically^{**)}. This procedure was successful as illustrated by Fig. 15. It was stated in Section 3-d that for $\nu > 1/8$ there are two types of asymptotic solutions and the actual solution may approach either one. Figure 15 shows the quantity $\Delta \equiv \beta - 3$ as function of $\epsilon \equiv \phi - \bar{\phi}$. The solution of the approximate differential equations approaches

*)

The details of these numerical computations are contained in [8].

**)

The expansions indicate that near $\phi = \bar{\phi}$ cancellations of leading terms up to high order occur, which explains the difficulty encountered.

the negative branch of the asymptotic solution of Type 2 for very small values of ϵ . The curve shown is part of the solution for $\frac{p_o}{k} = 10.5$. The integral of the original differential equations even with double precision approaches the asymptotic solution not well and is in this range inaccurate. However, the solution of the original and of the approximate differential equations agreed very well for $\epsilon > 5 \times 10^{-5}$, which fact could not be shown in the scale of Fig. 15. The complete results for the case $\frac{p_o}{k} = 10.5$, corresponding to Fig. 15, are shown in Fig. 14c.

Solutions for other values of ν and V are essentially similar, except for solutions for large values of $\frac{p_o}{k}$ when $\nu < 1/8$, because the asymptotic behavior near $\phi = \bar{\phi}$ changes. To illustrate such a case, Figs. 16a-c give solutions for $\nu = 0$, $V = 1.25 c_p$, where $\frac{p_E}{k} = 1.41$ and $\frac{p_L}{k} = 2.40$. Figures 16a, b apply respectively for $\frac{p_E}{k} < \frac{p_o}{k} = 2.17 < \frac{p_L}{k}$ and $\frac{p_L}{k} < \frac{p_o}{k} = 3.70$. Figure 16c finally applies for $\frac{p_o}{k} = 8.02$ a case where the numerical integration of Eqs. (3-35 to 38) encountered computing difficulties.

As discussed in general in Section 3-d, in the last case, the singular angle $\bar{\phi}$ is situated in the interior of the upper plastic region, and the asymptotic expressions for $\Delta = \beta - 3$ $\eta = \gamma - \pi/2$ as function of $\epsilon = \phi - \bar{\phi}$ differ for $\epsilon < 0$ and $\epsilon > 0$, and are discontinuous at $\epsilon = 0$. Figures 17, 18 show Δ and η given by the asymptotic expressions and the actual

integral obtained. For the value $\frac{p_o}{k} = 8.02$ considered, the approximate differential equations obtained by expansion of Eqs. (3-35 to 38), [8], had to be used. Figure 17 also shows a solution for a lower value $\frac{p_o}{k}$ where Eqs. (3-18 to 21) could still be integrated using double accuracy. As stated earlier, solutions for various values of the surface pressure $\frac{p_o}{k}$ are obtained by changing the end point ϕ_2 of the lower plastic region. In the range under discussion the computation becomes very sensitive to small changes in ϕ_2 . If an upper bound, which can only be found numerically, is exceeded the integration no longer leads to a solution because the value θ instead of approaching the value $\theta = 90^\circ$ moves away from it. Figure 17 shows also one of the integrals which does not lead to a solution.

Solutions in Range II, i.e. for values of ν and $\frac{V}{c_p}$ located in the cross-hatched area of Fig. 8, do not differ from those in Range I, except when $\frac{p_o}{k} < \frac{p_L}{k}$. As illustration Fig. 19 treats the case $\nu = .35$, $V = 1.25 c_p$ for the surface pressure $\frac{p_E}{k} < \frac{p_o}{k} = 4.41 < \frac{p_L}{k} = 6.24$. In this solution an elastic region occurs for $\phi > \phi_S$.

b) Conclusions.

The effects of a step pressure p_o progressing with constant superseismic velocity $V > c_p$ on the surface of a half-

space have been determined for an elastic-plastic medium obeying the von Mises yield condition. The steady-state solutions obtained satisfy additional conditions selected to ensure that the solutions are asymptotic ones in the vicinity of the front of the surface load for transient problems of the type shown in Fig. 2.

In spite of the lack of a general uniqueness and existence theorem, a unique solution was obtained for each combination of the significant nondimensional parameters $\frac{V}{c_P}$, ν and $\frac{P_O}{k}$ for which numerical computations were actually made. Extensive numerical results, in addition to the typical ones discussed above can be found in [8].

The elastic-plastic configuration of the solution differs, there being three cases, Figs. 10, 12, 13, depending on the value of the nondimensional parameters. For pressures $\frac{P_O}{k}$ below a value $\frac{P_E}{k}$, which is a function of ν and $\frac{V}{c_P}$, the solutions are entirely elastic. For larger values of the pressure, in a range $\frac{P_E}{k} < \frac{P_O}{k} \leq \frac{P_L}{k}$, the solutions contain one plastic region, the configurations being shown in Figs. 10 and 12. The former, or the latter applies when the parameters ν and $\frac{V}{c_P}$ are in Range I or Range II, respectively, see Fig. 8. For values of the nondimensional pressure $\frac{P_O}{k}$ above a limiting value $\frac{P_L}{k}$, which is of course a function of ν and $\frac{V}{c_P}$, two plastic regions occur as shown in the typical configuration

Fig. 13.

Two significant features common to all elastic-plastic solutions found should be noted.

1. While in one dimensional plane or spherical problems, discontinuous plastic fronts occur, [5], [10], they do not exist in the solutions of the two dimensional problem solved.
2. All solutions obtained contain an elastic discontinuity at the S-front, in addition to the one at the P-front. The latter occurs also in one-dimensional problems and is to be expected from general considerations of wave propagation. Such considerations also permit prediction of the possibility of a discontinuity in shear similar to the one in the elastic solution. The solutions found show that this discontinuity occurs in all cases, a fact which can not be established by purely qualitative considerations.

In view of the asymptotic character of the solutions obtained, it must be expected that these two features will be found also in steady-state solutions for non-step loads, Fig. 1, and in transient cases, Fig. 2.

The present paper is the first one to give results for

multidimensional wave propagation in elastic-plastic media, except for purely numerical, finite difference schemes*) in which discontinuities can not appear. The solutions found in the present paper permit checks on the effectiveness of these numerical schemes, particularly in the vicinity of discontinuities in the actual solution.

As a by-product of the steady-state solution for the step load, the character of the partial differential equations for the general case was examined in Appendix B. For superseismic velocities $V > c_p$ the equations were found to be hyperbolic.

The method used in this paper is also applicable to cases with other yield conditions. The equivalent problem for a yield condition

$$J_2 - \alpha^2 J_1^2 = 0 \quad (5-1)$$

has been treated concurrently with the present problem [12].

*) Computer programs, not published, or given limited distribution only have been developed by a number of organizations for various purposes, an example being [11].

APPENDIX A - Asymptotic Solution of Equations (3-35,36,37).

The asymptotic equations (3-35,36,37) have been derived without assumption on the relative magnitude of the quantities η , Δ and ϵ , the leading terms in each quantity were retained in each equation. Further simplifications of the asymptotic equations are possible by studying separately the various possibilities for the relative magnitude of η and Δ .

If η and Δ are of equal magnitude, Eq. (3-35) requires that in the limit $\epsilon \rightarrow 0$ the relations

$$\Delta = c_1 \sqrt{\epsilon} \quad \eta = c_2 \sqrt{\epsilon} \quad (A-1)$$

hold, where c_1 and c_2 are constants, This assumption leads, however, to a contradiction. Substituting Eq. (A-1) in Eq. (3-37), $a_3 \eta^2$ is in the limit negligible compared to Δ , so that

$$L = - \frac{1}{2\epsilon} \quad (A-2)$$

Substituting this expression and the value of η into Eq. (3-36), the term unity is negligible compared to $a_4 \eta L$. The result requires $a_4 = -1$, valid only for $\nu = 1/2$. This value corresponds to an incompressible material where $c_p = \infty$, so

that the superseismic problem to be studied here, does not exist. Solutions according to Eqs. (A-1) do not apply here.

Solutions of Type 1. If, in the limit $\epsilon \rightarrow 0$, $\eta \gg \Delta$, Eq. (3-35) requires

$$\eta = \sqrt{\frac{a_2}{a_1} \epsilon} \quad (\text{A-3})$$

The unity term being small compared to $\frac{1}{\sqrt{\epsilon}}$, Eq. (3-36) gives

$$L = \frac{1}{2a_4 \epsilon} \quad (\text{A-4})$$

The requirement $L > 0$ restricts the sign of ϵ for which the solution applies to $\text{sign } \epsilon = \text{sign } a_4$. Inspection of Eqs. (3-39) shows that this requirement ensures $\frac{a_2 \epsilon}{a_1} > 0$, so that Eq. (3) gives real values of η .

Substitution of Eqs. (A-3,4) into Eq. (3-37) gives the differential equation

$$2a_4 \epsilon \frac{d\Delta}{d\epsilon} + \Delta = \frac{a_2 a_3}{a_1} \epsilon \quad (\text{A-5})$$

the general solution of which is

$$\Delta = C\epsilon^{-\frac{1}{2a_4}} + \frac{a_2 a_3 \epsilon}{a_1 (1 + 2a_4)} \quad (\text{A-6})$$

where C is an arbitrary constant. However, the solution (A-6) must satisfy the premise $\Delta \ll \eta$ where η is given by Eq. (A-3). If the constant C does not vanish the exponent of ϵ in the above expression must be larger than $1/2$, or $\frac{-1}{a_4} > 1$. Use of the expression for a_4 , Eq. (3-39), indicates that the inequality requires $\nu > 1/2$, an impossible requirement. The constant C must therefore vanish, and

$$\Delta = \frac{a_2 a_3 \epsilon}{a_1 (1 + 2a_4)} \quad (\text{A-7})$$

The signs of a_4 and of $\frac{a_2}{a_1}$ which govern the sign of ϵ , depend on the value of ν . The solution applies for $\epsilon > 0$ when $\nu < 1/8$, and for $\epsilon < 0$ when $\nu > 1/8$. The denominator in Eq. (A-7) does not vanish in the range $0 \leq \nu \leq 1/2$, so that the result applies except for the previously excluded value $\nu = 1/8$.

Solutions of Type 2. If, in the limit $\epsilon \rightarrow 0$, $\Delta \gg \eta$, Eq.

(3-35) requires

$$\Delta = \sqrt{-a_2 \epsilon} \quad (\text{A-8})$$

a_2 being always positive, this solution applies only for $\epsilon < 0$. Due to the premise $\Delta \gg \eta$ the term $a_3 \eta^2$ in Eq. (3-37) is, in the limit, small compared to Δ , giving

$$L = \frac{-1}{2\epsilon} \quad (\text{A-9})$$

The value of η is to be determined from the differential Equation (3-36) after substitution of Eq. (A-9),

$$\epsilon \eta' + \frac{a_4}{2} \eta = \epsilon \quad (\text{A-10})$$

If $a_4 \neq -2$, the general solution of this differential equation is

$$\eta = C \epsilon^{-\frac{a_4}{2}} + \frac{2\epsilon}{2 + a_4} \quad (\nu \neq 2/7) \quad (\text{A-11})$$

while for $\nu = 2/7$, when $a_4 = -2$

$$\eta = C \epsilon + \epsilon \ln \epsilon \quad (\text{A-12})$$

where C indicates an arbitrary constant.

The premise $\Delta \gg \eta$ limits the exponent in the first term of Eq. (A-11), $-\frac{a_4}{2} > 1/2$. This condition is not satisfied for $\nu < 1/8$, requiring $C = 0$, but it is satisfied for values of $\nu > 1/8$. Equation (A-12) for $\nu = 2/7$ also satisfies the premise $\Delta \gg \eta$, so that the constant C does not vanish in Eqs. (A-11,12) if $\nu > 1/8$. For $\nu < 1/8$ the solution for η approaches therefore asymptotically the expression

$$\eta = \frac{2\epsilon}{2 + a_4} \quad (\nu < 1/8) \quad (A-13)$$

while the expressions for $\nu > 1/8$ contain an arbitrary constant and are not fully defined. While it is possible to find a range of ν where in the limit $\epsilon \rightarrow 0$ the term containing C is negligible, the matter need not be pursued because it will be seen in the examples that for $\nu > 1/8$ it is sufficient to know that $\eta \ll \Delta$, so that one can use the approximation

$$\Delta \gg \eta \sim 0 \quad (\nu > 1/8) \quad (A-14)$$

in conjunction with Eqs. (A-8,9) for Δ and L.

APPENDIX B - Proof for the Hyperbolic Character of Equations (2-14,15) and Bounds on Characteristics.

The differential equations applicable for steady state solutions in plastic regions are the six relations (2-14,15) supplemented by the yield condition, $F = 0$. To prepare the system for the manipulations required to obtain the characteristic directions, the function λ , the derivative of which does not occur in Eqs. (14), (15), may be considered to be the derivative with respect to ξ of another function Λ , or $\lambda = \frac{\partial \Lambda}{\partial \xi}$. Further, differentiation of the yield condition converts it into a differential equation, $\frac{\partial F}{\partial \xi} = 0$, a total of seven for seven unknowns.

These seven differential equations can be combined with expressions for the derivatives of the unknowns f in the direction ϕ of a characteristic, if any,

$$\cos \phi_i \frac{\partial f}{\partial \xi} + \sin \phi_i \frac{\partial f}{\partial y} = \frac{\partial f}{\partial r} \quad (B-1)$$

where r is a new variable. The coefficients of the derivatives with respect to ξ and y form a determinant which must vanish in a hyperbolic system for seven, real, characteristic angles ϕ_i . It is, however, not necessary to derive the characteristic equation, because the seven differential equations are

not only quasi-linear, but also homogeneous in the derivatives $\frac{\partial f}{\partial \xi}$, $\frac{\partial f}{\partial y}$. In such a case the determinant for the determination of the characteristic angles ϕ_i is necessarily identical with the determinant obtained by substitution of the relations (2-24,25) into the differential equations. This substitution was made in Section 2 after a change of variables which cannot be material, so that the determinant of Eqs. (2-45) must vanish for characteristic values ϕ_i . This is precisely the condition which leads to the determinantal Equation (3-13), which applies thus for the values ϕ_i , too. However, it will be seen that Eq. (3-13) gives four, not seven roots ϕ_i , which difference can be traced to disregarded factors containing powers of $\sin \phi$, which were of no consequence in Section 3. That there is a triple root $\phi_i = 0$, as required for a total of seven, may be proved by showing that the matrix of the coefficients of the derivatives $\frac{\partial f}{\partial y}$ in the combined Eqs. (2-14,15) and $\frac{\partial F}{\partial \xi} = 0$ is of order seven but only of rank four.

To demonstrate the hyperbolic character of the differential equations for the steady-state the roots of Eq. (3-13) must be studied. This equation, omitting the unessential factor $(s_1 + s_2)^2$, may be written

$$C \equiv [\beta \cos 2\gamma + (1-2\nu)(1-2X)]^2 + 2[1 + (1-2\nu)(1-2X)][(1+\nu)(1-2X) - \beta^2 X] = 0 \quad (B-2)$$

where the values X and γ contain ϕ

$$\left. \begin{aligned} X &= \frac{\rho V^2}{2G} \sin^2 \phi \\ \gamma &= \phi - \theta \end{aligned} \right\} \quad (B-3)$$

For given values of the velocity V and of the properties ρ , G , ν of the material, Eq. (B-2) defines ϕ implicitly as function of θ and β , which describe the state of stress at the point considered. Substitution of Eqs. (B-3) leads to a quartic in $\tan \phi$, so that the direct investigation of the character of its roots is an unpleasant prospect. An alternative approach will be used here.

Consider first the properties of the roots X of Eq. (B-2) as functions of β and γ . Equation (B-2) is quadratic in X :

$$C \equiv 4(1-2\nu)(3+\beta^2)X^2 - 4[(4-5\nu) + (1-\nu)\beta^2 + (1-2\nu)\beta \cos 2\gamma]X + \beta^2 \cos^2 2\gamma + 2(1-2\nu)\beta \cos 2\gamma + 5 - 4\nu = 0 \quad (\text{B-4})$$

To prove that this equation must have two positive roots X , it is noted that examination of the X -independent term shows $C > 0$ for $X = 0$. The coefficient of X^2 in the range $0 \leq \nu < 1/2$ *) being positive, C is also positive for sufficiently large values of X . The proof is completed by the demonstration in the next paragraph that there is a positive value X for which $C < 0$.

It is proved in [6] in the transient case that one pair of characteristic velocities is always above, one below the speed c_s of elastic shear waves. The equivalent holds here for X and is shown by substitution of the appropriate value

$$X_s = 1/2 \quad (\text{B-5})$$

in Eq. (B-2),

*)

The value $\nu = 1/2$ need not be considered as pointed out in Appendix A.

$$C |_{X=1/2} = \beta^2 [\cos^2 2\gamma - 1] \quad (B-6)$$

Excepting the cases $\beta = 0$ or $\cos 2\gamma = \pm 1$ when C vanishes, Eq. (B-6) gives negative values of C , so that there are two distinct real roots $0 < x_1 < 1/2$, $x_2 > 1/2$. The special cases $\beta = 0$ and $\cos 2\gamma = \pm 1$ require consideration of the discriminant D of Eq. (B-4),

$$D = (1-2\nu)\beta^2(3+\beta^2) \sin^2 2\gamma + [(1-2\nu)\beta \cos 2\gamma + 1 + \nu]^2 + \nu\beta^2[\nu\beta^2 + 2(1-2\nu)\beta \cos 2\gamma + 2(1+\nu)] \quad (B-7)$$

If $\beta = 0$ the value of D becomes $(1+\nu)^2 \neq 0$ so that $X = 1/2$ is a root but not a double one. If $\cos 2\gamma = \pm 1$, $\sin 2\gamma \equiv 0$, let

$$\bar{\beta} = \beta \cos 2\gamma \quad (B-8)$$

and $\bar{\beta}^2 \equiv \beta^2 \cos^2 2\gamma = \beta^2$. The discriminant (B-7) is then a function of $\bar{\beta}$ and ν only, and of the surprisingly simple form

$$D \Big|_{\cos 2\gamma = \pm 1} = [(\bar{\beta} - 1)^2 v + \bar{\beta} + 1]^2 \quad (\text{B-9})$$

The value $X = 1/2$ will therefore be a double root if

$$\cos^2 2\gamma = 1, \quad \text{and } v = - \left[\frac{\beta \cos 2\gamma + 1}{(\beta \cos 2\gamma - 1)^2} \right] \quad (\text{B-10})$$

Allowing for the special cases, it has been shown so far that for given values β and γ , Eq. (B-2), has only real positive roots X ,

$$0 < X_1 \leq 1/2 \leq X_2 \quad (\text{B-11})$$

The roots are equal, $X_1 = X_2 = 1/2$ if Eqs. (B-10) hold.

Studying $X(\beta, \gamma)$ as a function of γ alone, relative maxima and minima of X for any given value of β must satisfy the equation

$$\frac{\partial C}{\partial \gamma} \equiv -4\beta \sin 2\gamma [\beta \cos 2\gamma + (1-2v)(1-2X)] = 0 \quad (\text{B-12})$$

This will be used to find an upper bound on X_2 . Equation (B-12) gives three possibilities:

$$\beta \cos 2\gamma = - (1-2\nu)(1-2X), \text{ or } \sin 2\gamma = 0, \text{ or } \beta = 0$$

Case a. When $\beta \cos 2\gamma = - (1-2\nu)(1-2X)$, Eq. (B-2) becomes

$$C_a = [1+(1-2\nu)(1-2X)][(1+\nu)(1-2X) - \beta^2 X] = 0 \quad (\text{B-13})$$

which gives either

$$X_a = \frac{1-\nu}{1-2\nu} \equiv X_p \quad (\text{B-14})$$

independent of β , or

$$X_a = \frac{1+\nu}{2(1+\nu) + \beta^2} \quad (\text{B-15})$$

The maximum of the latter value, which occurs for $\beta = 0$ is $1/2$. X_p being larger than $1/2$ the result (B-15) never controls.

Case b. $\sin 2\gamma = 0$. In this case $\cos 2\gamma = \pm 1$ and the value of C is

$$C_b = [\pm\beta + (1-2\nu)(1-2X)]^2 + 2[1+(1-2\nu)(1-2X)][(1+\nu)(1-2X) - \beta^2 X] \quad (\text{B-16})$$

Substituting the maximum value of X found in Case a, from Eq. (B-14) into Eq. (B-16) one finds

$$c_b \Big|_{X_a = \frac{1-v}{1-2v}} = [\pm\beta - 1]^2 > 0 \quad (B-17)$$

It was previously demonstrated that the value of C is not positive for $X = 1/2$ and that there can be only one root $X > 1/2$. The value c_b for $X = X_a$ being positive, the only root of Eq. (B-16) for which $X_b > 1/2$ must be less than $X_a = \frac{1-v}{1-2v}$. Case b cannot furnish the upper bound.

Case c. In this case $\beta = 0$ and

$$c_c = (1-2X)[3(1-2v)(1-2X) + 2(1+v)] \quad (B-18)$$

This equation gives $X_c = 1/2$, which is not a maximum, and

$$X_c = \frac{5-4v}{6(1-2v)} \quad (B-19)$$

Comparison with the value of $X_a \equiv X_p$, Eq. (B-14), indicates that $X_c < X_p$ regardless of the value of v .

While the controlling maximum, Eq. (B-14), was derived

by a search for relative maxima of X for given values of β , the largest value of X found being independent of β , it is the absolute upper bound. For any selected pair of values β and γ , Eq. (B-2), has therefore two positive roots, subject to the following bounds:

$$0 < x_1 \leq 1/2, \quad 1/2 \leq x_2 \leq x_p \equiv \frac{1-\nu}{1-2\nu} \quad (\text{B-20})$$

Changing from the values X to the more pertinent values ϕ , Eq. (B-3) gives

$$\sin \phi = \sqrt{\frac{2G}{\rho v^2}} X \quad (\text{B-21})$$

The upper bound in Eq. (B-20), $x \leq \frac{1-\nu}{1-2\nu}$, assures that Eq. (B-21) gives real values ϕ for superseismic velocities

$$v > \sqrt{\frac{2(1-\nu)G}{(1-2\nu)\rho}} \quad (\text{B-22})$$

Restricting the range of ϕ to the meaningful one, $0 \leq \phi < \pi$ it has therefore been demonstrated that Eq. (B-2) has two pairs

of real roots ϕ_i , $\pi - \phi_i$, and no others, for any pair of values γ and β . Double roots $\phi = \phi_S$ occur when Eqs. (B-10) apply. The roots are bounded

$$\left. \begin{aligned} 0 < \phi_1 < \pi - \phi_S, & \quad \pi - \phi_S < \phi_2 < \pi - \phi_P \\ \phi_P < \phi_3 < \phi_S, & \quad \phi_S < \phi_4 < \pi \end{aligned} \right\} \text{(B-23)}$$

The final step may now be taken, where the roots ϕ of Eq. (B-2) are considered as functions of β and θ . For a given value of β , any root ϕ_j satisfying Eq. (B-2) for a specified value γ , gives a combination ϕ and $\theta = \phi - \gamma$ which satisfies Eq. (B-2). It will now be demonstrated that variation of γ leads to solutions for any value of θ .

Figure B-1 shows a typical plot of $\phi(\gamma)$ for a fixed value of β . There are four curves, bounded by horizontal lines representing the bounds, Eq. (B-23). The value γ appears in Eq. (B-21) only in the form $\cos 2\gamma$, so that $\phi(\gamma)$ must be periodic, $\phi(\gamma) \equiv \phi(\gamma \pm \pi)$. Each of the four separate branches must be continuous as function of γ . (There can be no discontinuity because the standard form of solution of the quadratic equation (B-4) for X cannot lead to a discontinuity if X is always real.) The values ϕ which pertain to a prescribed value of θ appear in Fig. B-1 as intersection points

of a straight line, $\phi = \gamma + \theta$, with the curves $\phi = \phi(\gamma)$. There is obviously at least one value ϕ in each interval between the five horizontal bounding lines, for a total of four, except for the possibility of double roots which may occur for certain values of θ if the second Eq. (B-10) is satisfied. The purely qualitative Fig. B-1 does not prove that the straight line $\phi = \gamma + \theta$ cannot intersect the same branch more than once. This is, however, impossible because Eq. (B-2) is a quartic having at most four roots. The fact that Eq. (B-2) as function of the state of stress, θ and β is a quartic, not a bi-quadratic indicates also that the characteristic directions are not symmetric, i.e. in general $\phi_1 \neq \pi - \phi_4$, $\phi_2 \neq \pi - \phi_3$.

It has therefore been demonstrated that, including double roots, there are always four characteristic directions $\pi > \phi_i > 0$ for any state of stress, the values ϕ_i being subject to the inequalities (B-23). Due to the asymmetry mentioned in the last paragraph, only one double root $\phi > 0$ may occur for any state of stress, the other two roots remain different. In addition there is a triple root $\phi = 0$.

In final conclusion it has been proved that all seven characteristic directions are real, and the system is therefore hyperbolic. The occurrence of multiple roots does not create any difficulty affecting the nature of the differential

equations [7]*. While the details are not given here, it was found that along a double (triple) characteristic two (three) independent compatibility relations apply.

REFERENCES

1. Cole, J. D. and Huth, J. H., "Stresses Produced in a Half-Plane by Moving Loads", Journal of Applied Mechanics, Vol. 25, Trans. ASME, Vol. 80, pp 433-436, 1958.
2. Sackman, J. L., "Uniformly Progressing Surface Pressure on a Viscoelastic Half-Plane", Proc. 4th U.S. Congress of Applied Mechanics, June 1962.
3. Workman, J. W. and Bleich, H. H., "The Effect of a Moving Load in a Viscoelastic Half-Space", Office of Naval Research, Technical Report 12, Contract Nonr-266(34), November 1962.
4. Miles, J. W., "On the Response of an Elastic Half-Space to a Moving Blast Wave", Journal of Applied Mechanics, Vol. 27, pp 710-716, 1960.
5. Bleich, H. H. and Nelson, I., "Plane Waves in an Elastic-Plastic Half-Space due to Combined Surface Pressure and Shear", Office of Naval Research, Technical Report 36, Contract Nonr-266(86), January 1965.
6. Mandel, J., "Ondes Plastiques dans un Milieu Indéfini à Trois Dimensions", Journal de Mécanique, 1, pp 3-30, 1962.
7. Courant, R. and Hilbert, D., "Methods of Mathematical Physics", Vol. II, Interscience Publishers, New York, 1962.
8. Matthews, A. T. and Bleich, H. H., "Stresses in an Elastic-Plastic Half-Space due to a Superseismic Step Load", Rpt. No. 4 for Ballistics Research Laboratories, Aberdeen Proving Grounds, Aberdeen, Maryland. (Forthcoming)
9. Ralston, A. and Wilf, H. S., "Mathematical Methods for Digital Computers", John Wiley and Sons, Inc., January 1964.

10. Friedman, M., Bleich, H. H. and Parnes, R., "Spherically Symmetric Elastic-Plastic Shock Propagation", A.S.C.E. Journal of Engineering Mechanics Division, June 1965.
11. Wilkins, M. L., "Calculation of Elastic-Plastic Flow", University of California, UCRL-7322, Lawrence Rad. Lab., Livermore, California, April 19, 1963.
12. Bleich, H. H., Matthews, A. T. and Wright, J., "Step Load Moving with Superseismic Velocity on the Surface of a Half-Space of Granular Material", Air Force Weapons Laboratory, Contract AF29(601)-6055, 1965.

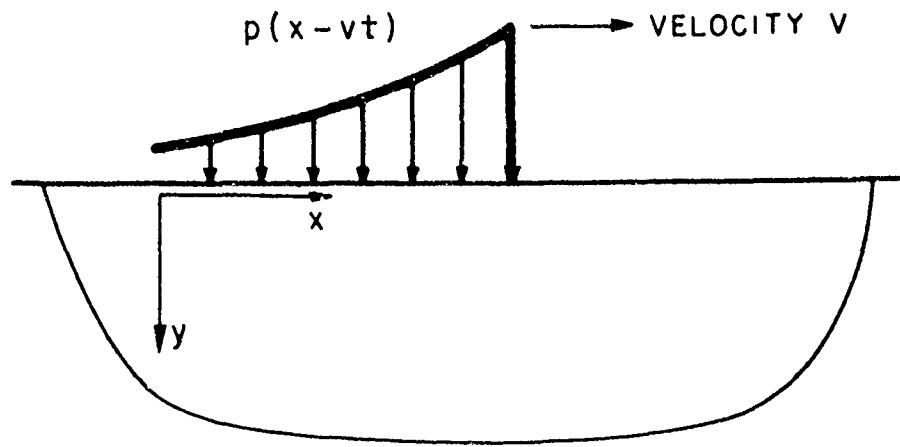

FIG. 1

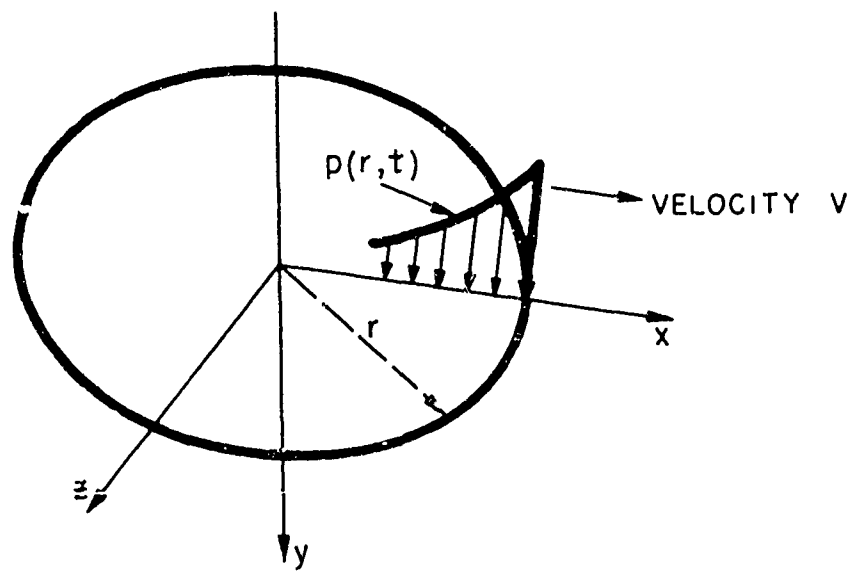

FIG. 2

BLANK PAGE

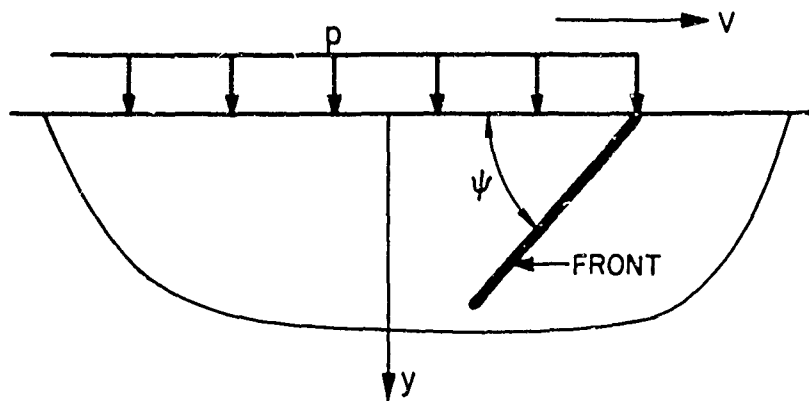

FIG. 3a

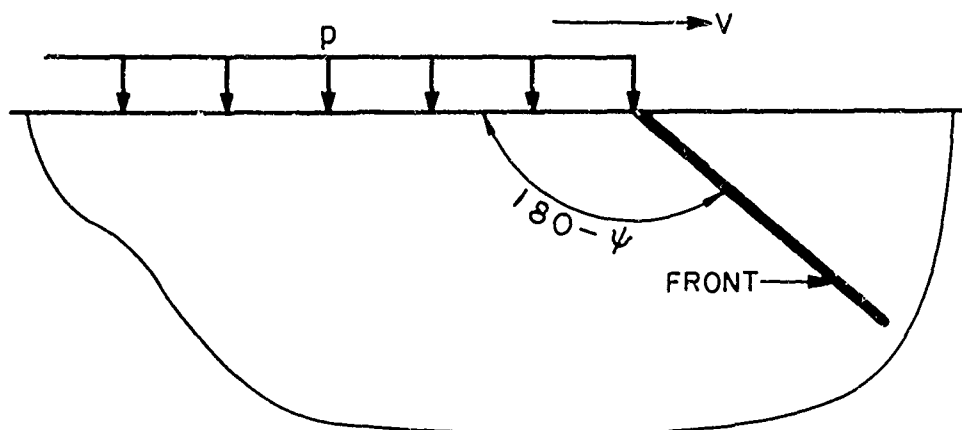

FIG. 3b

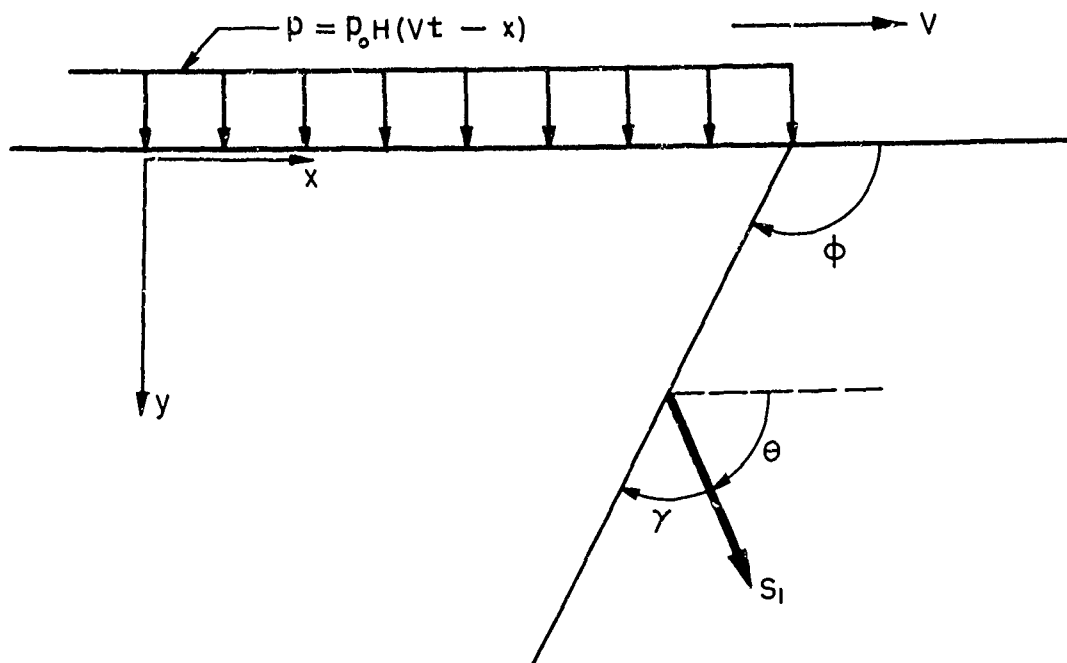

FIG . 4

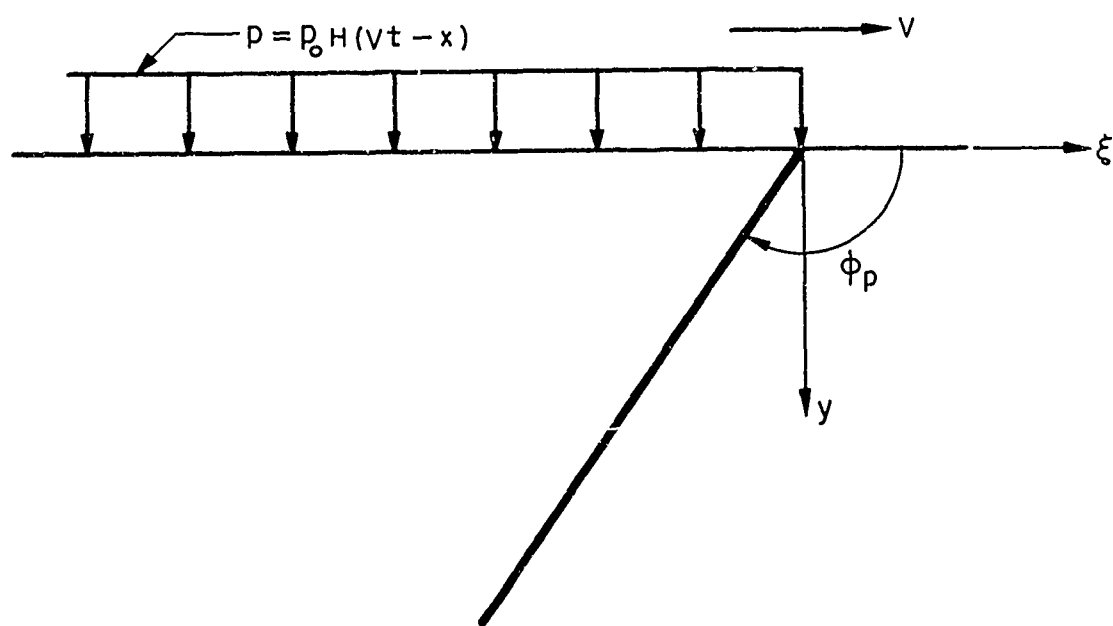

FIG . 5

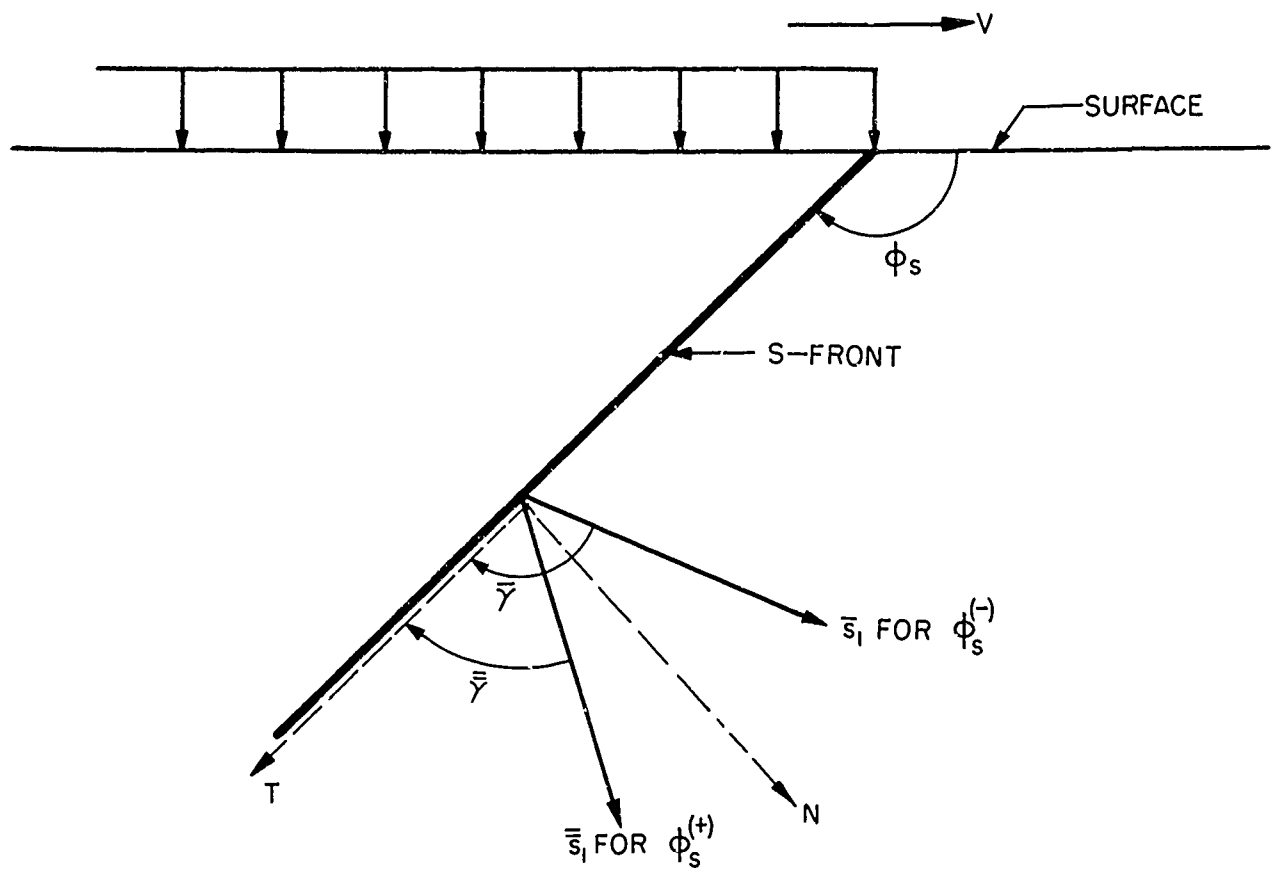

FIG. 6

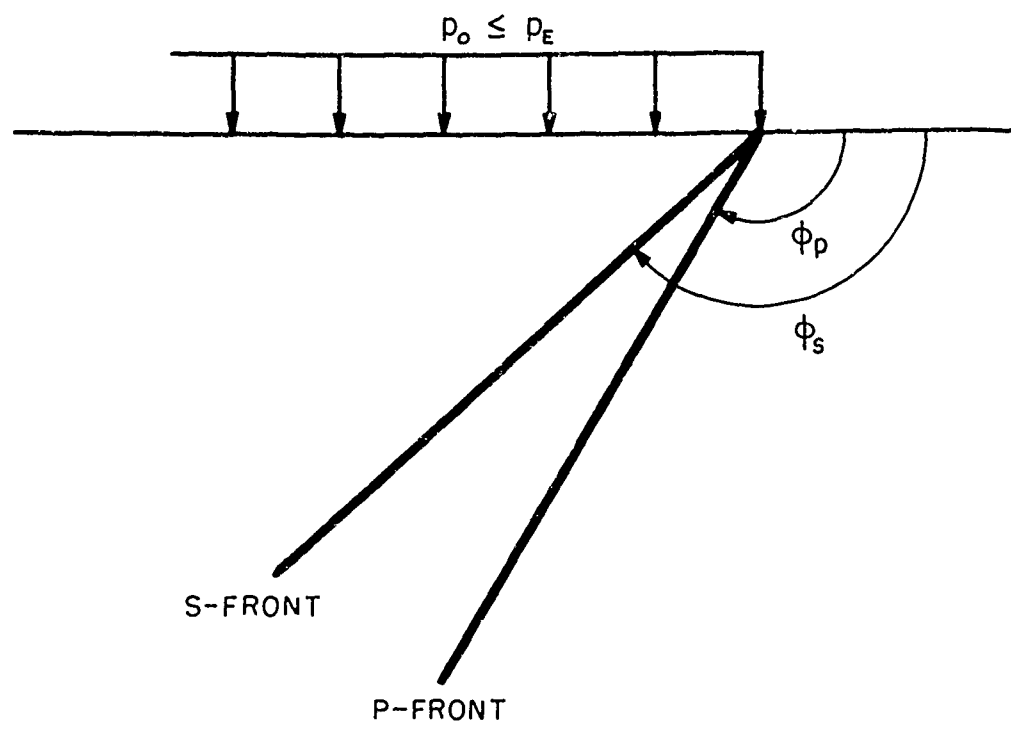

FIG. 7

CONFIGURATION OF ELASTIC SOLUTIONS

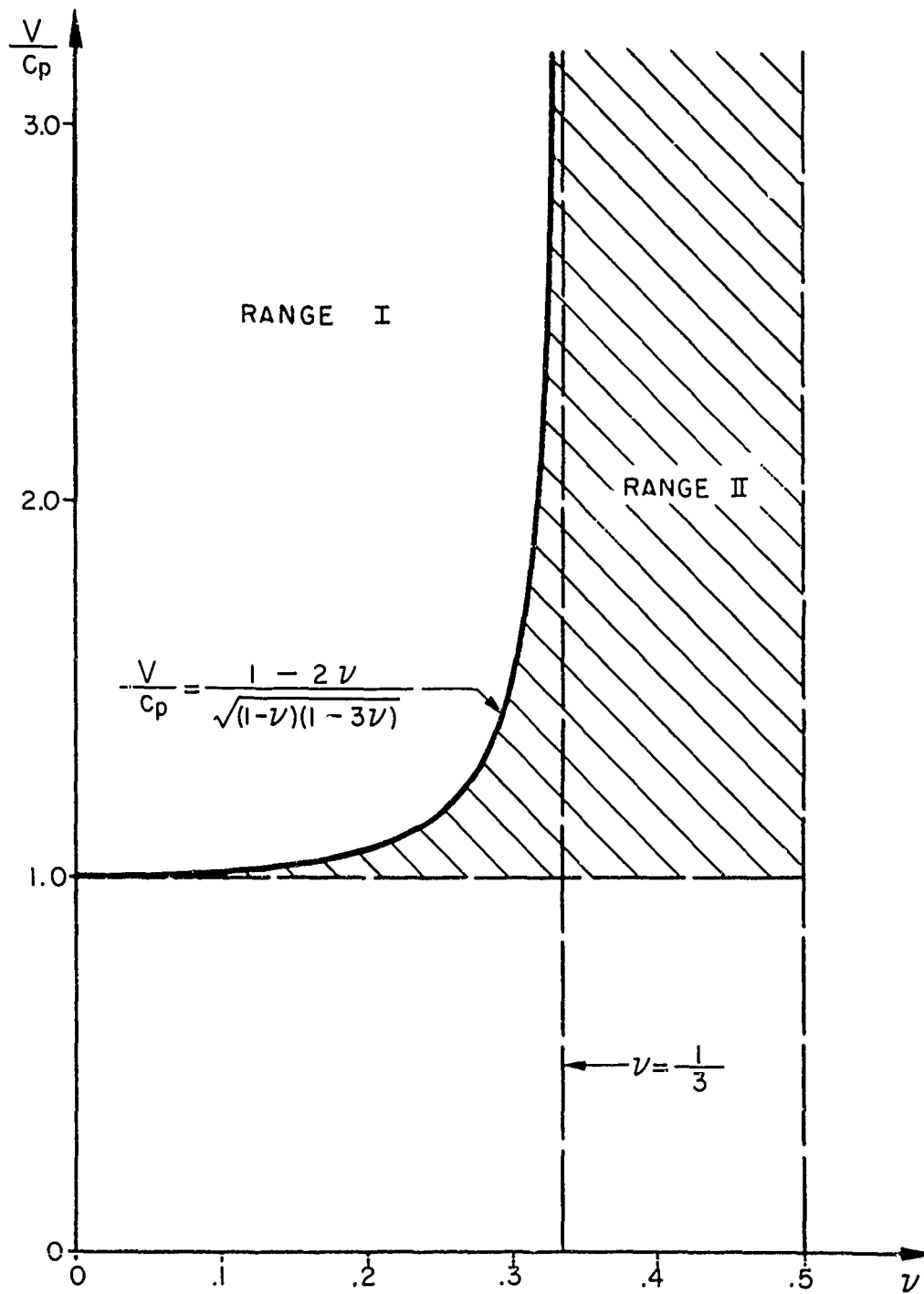

FIG . 8

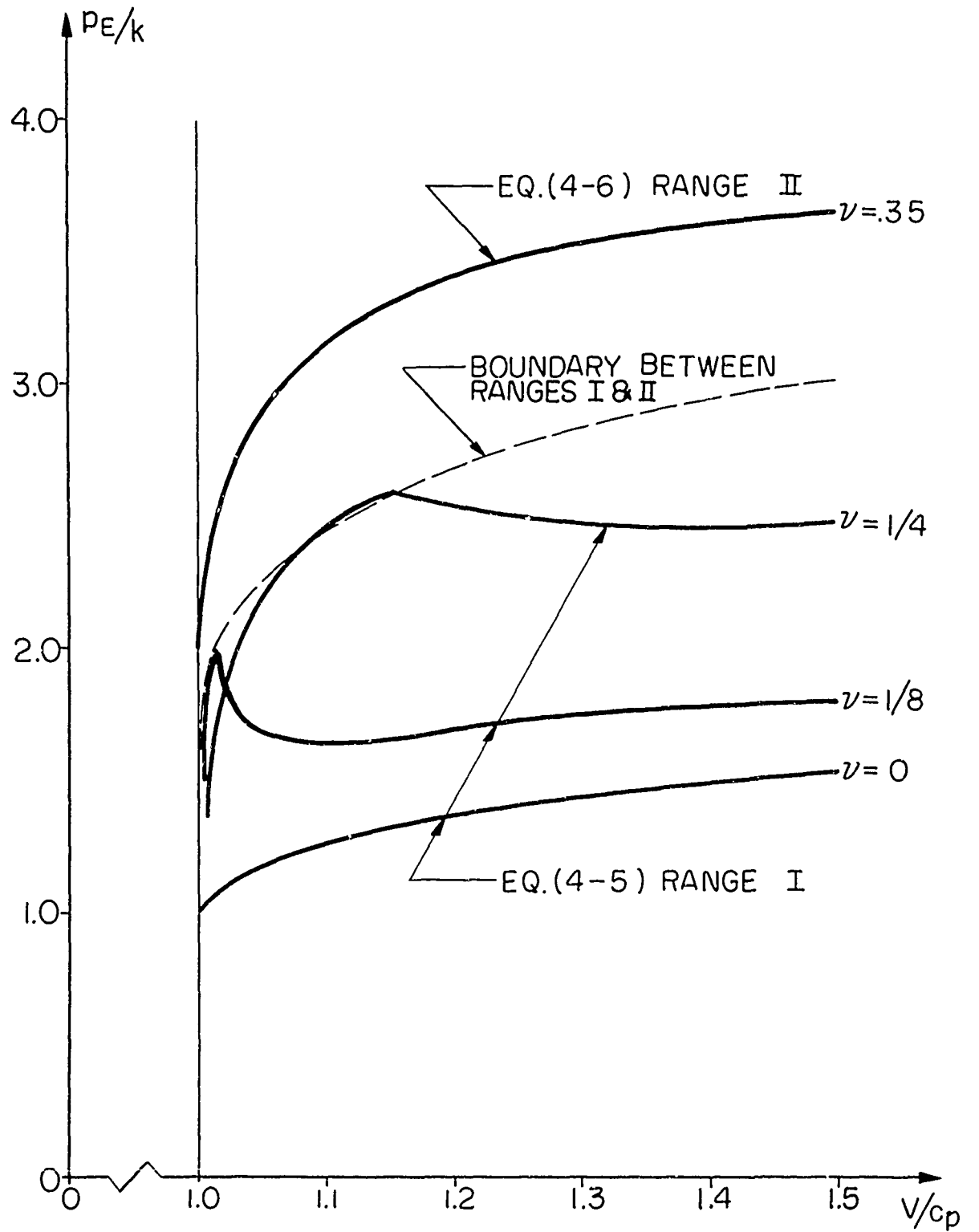

FIG 9
UPPER BOUND P_E/k TO ELASTIC SOLUTIONS

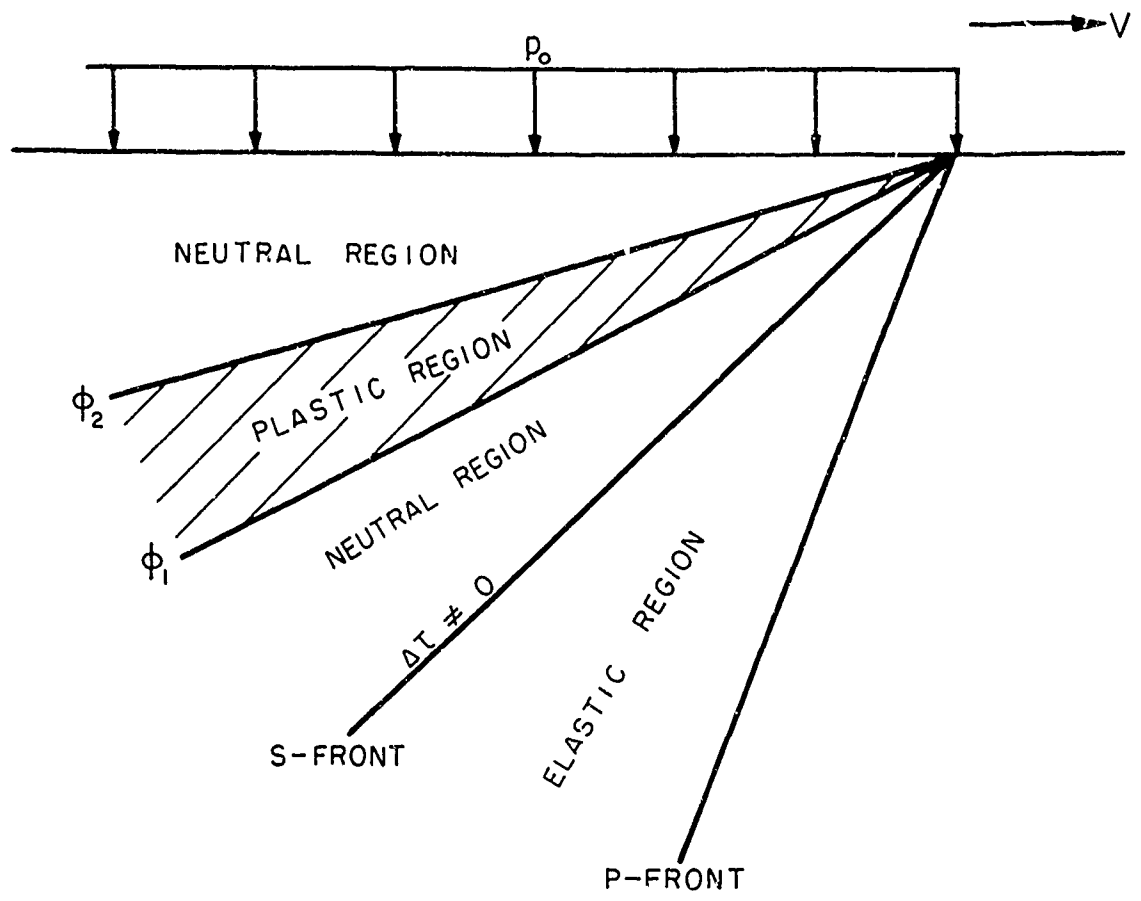

FIG. 10

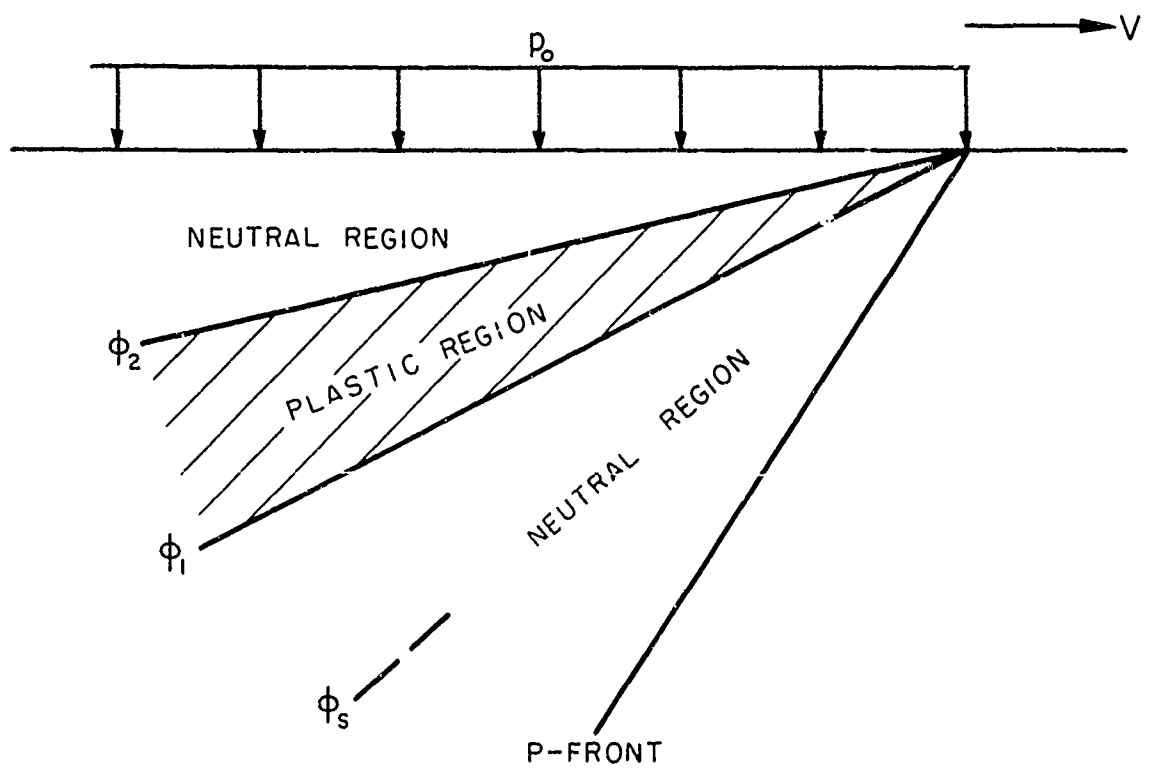

FIG. 11a

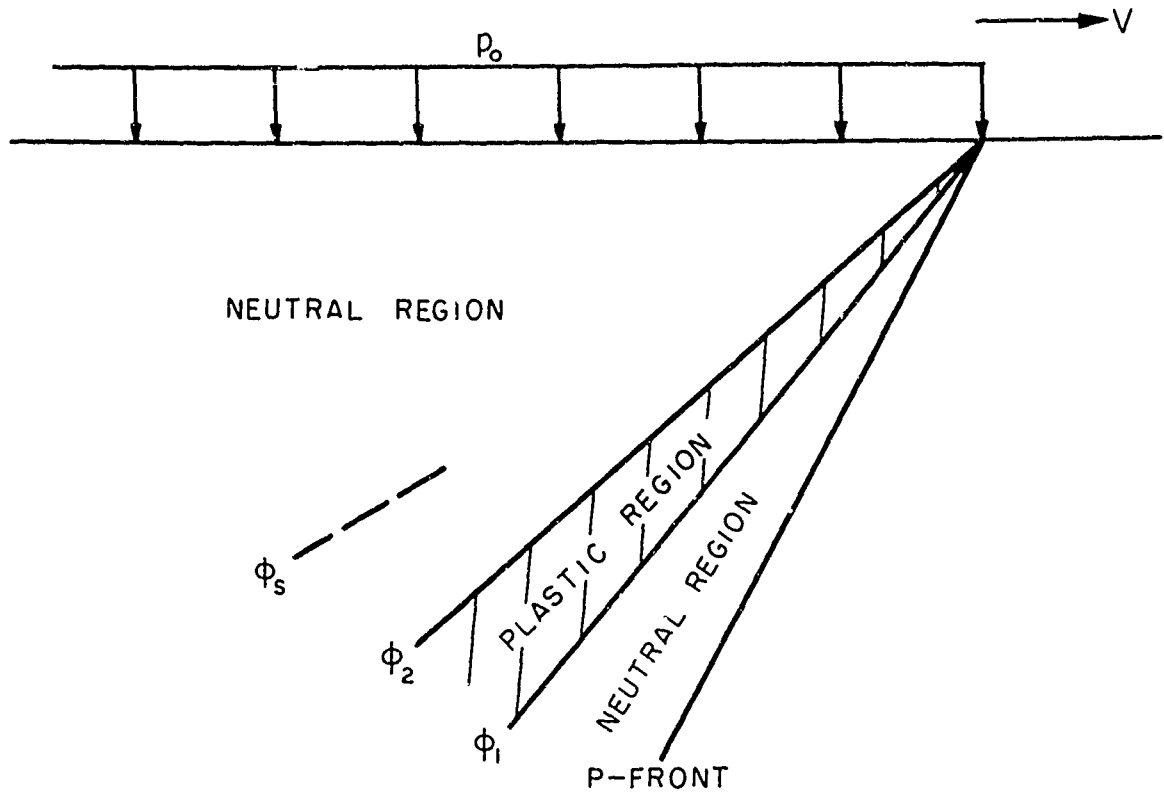

FIG. IIB

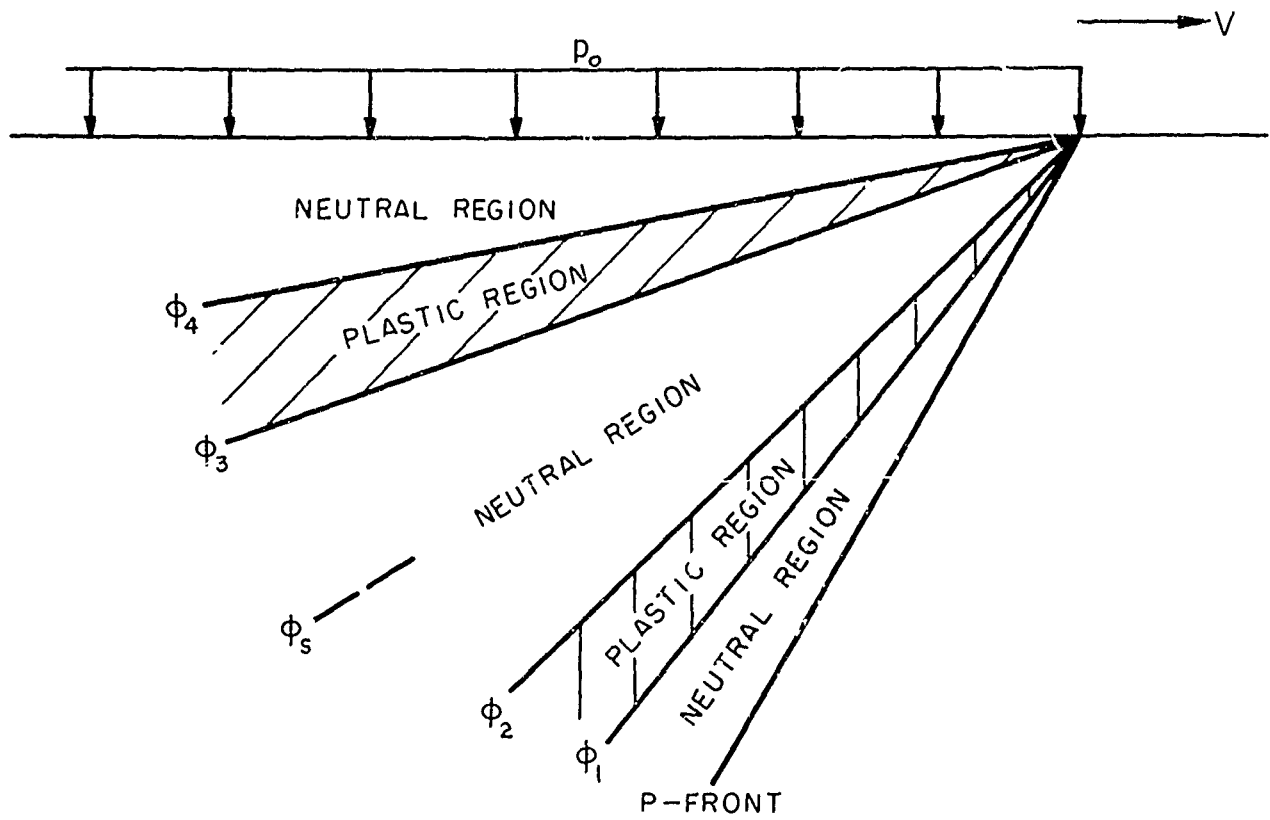

FIG. IIC

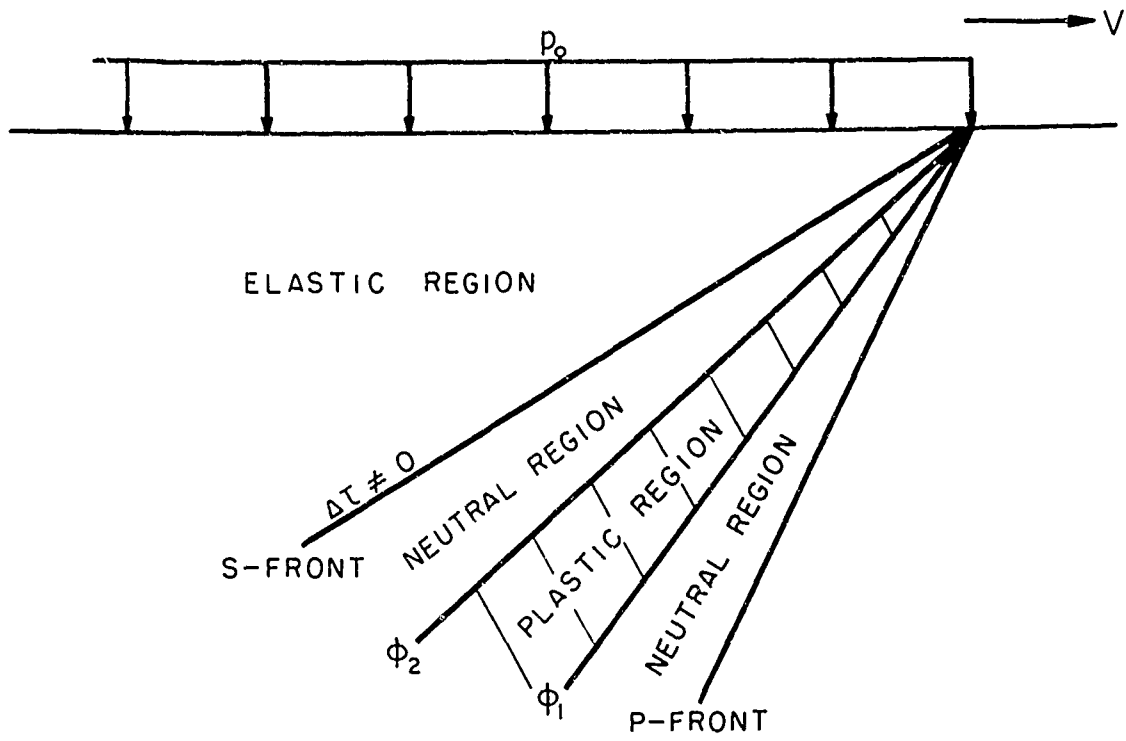

FIG. 12

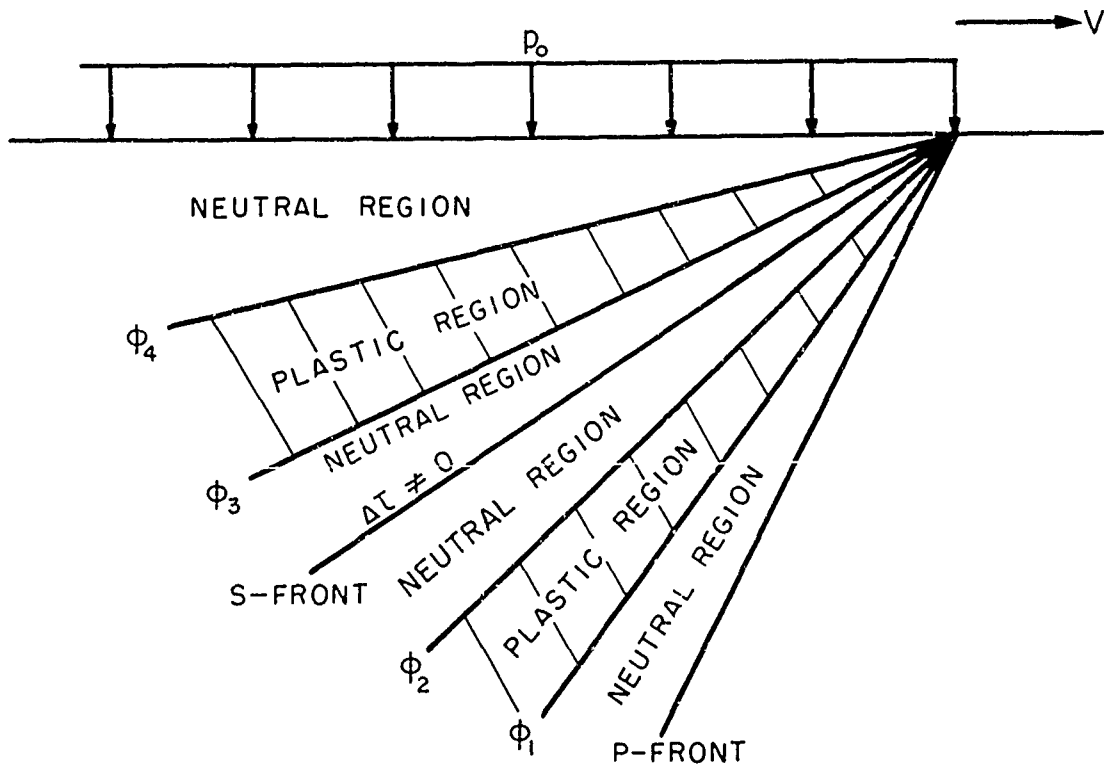

FIG. 13

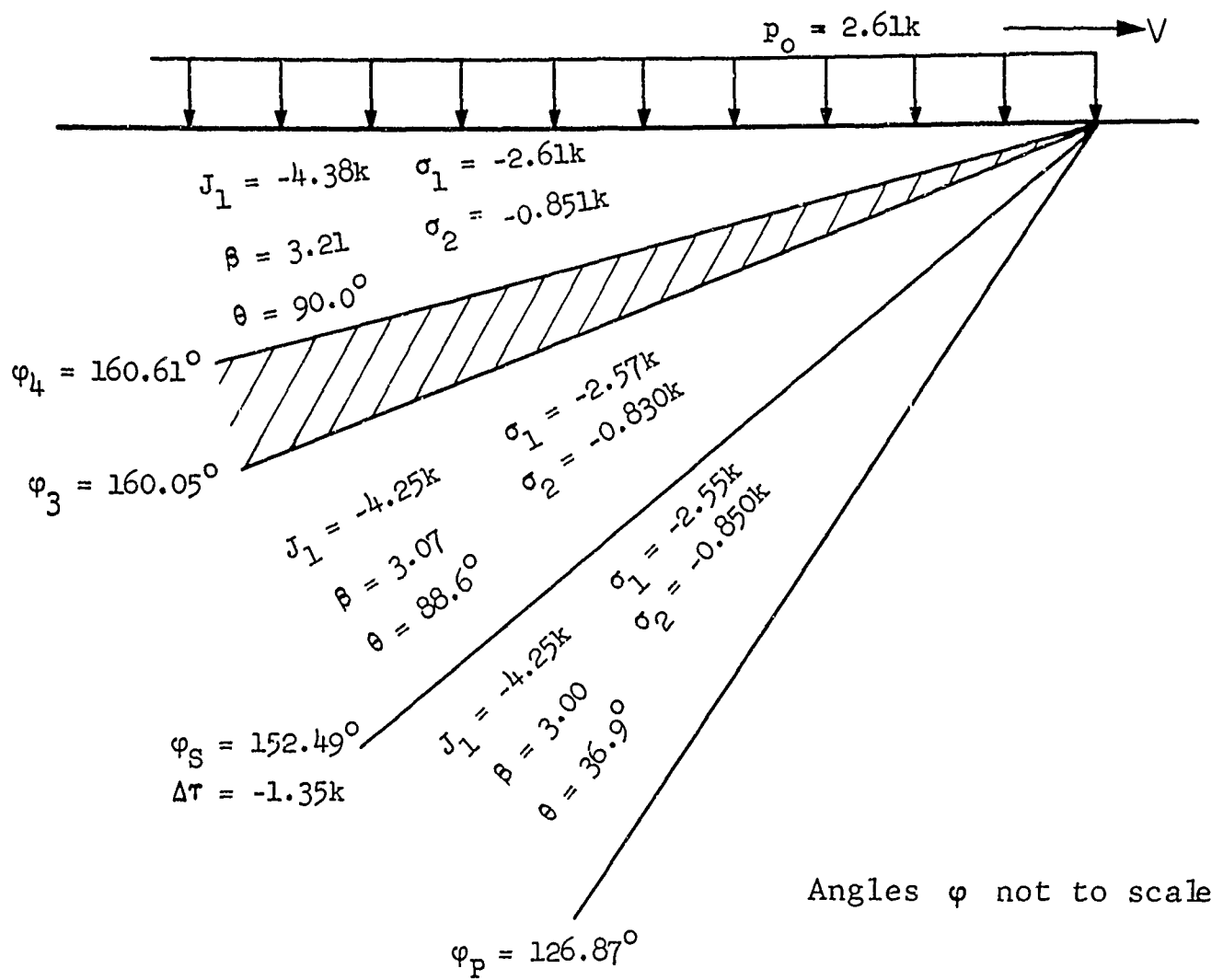

Fig. 14a

Result for $\nu = 0.25$, $V = 1.25 c_p$, $p_o = 2.61k$

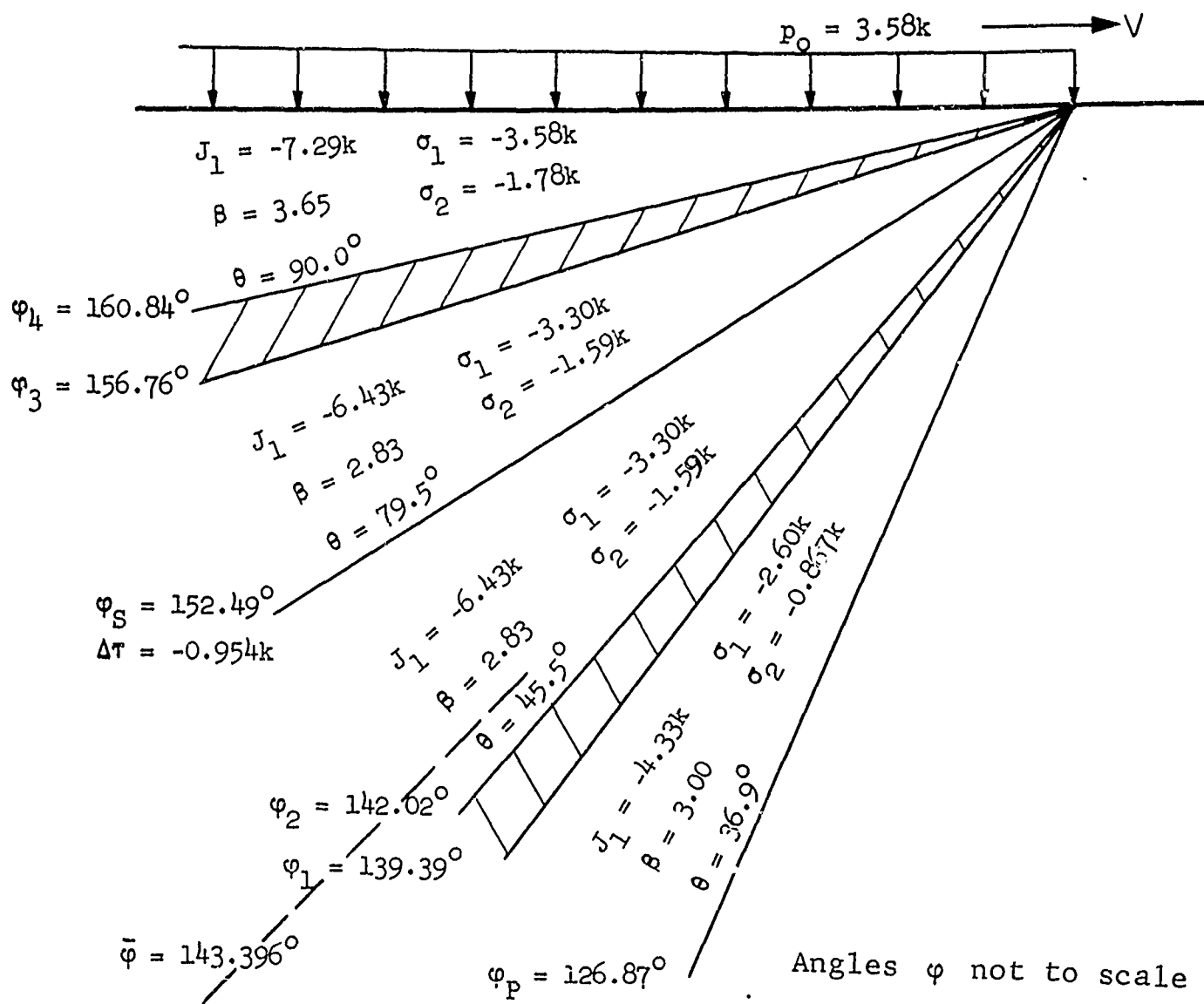

Fig. 14b

Result for $\nu = 0.25$, $V = 1.25 c_p$, $p_o = 3.58k$

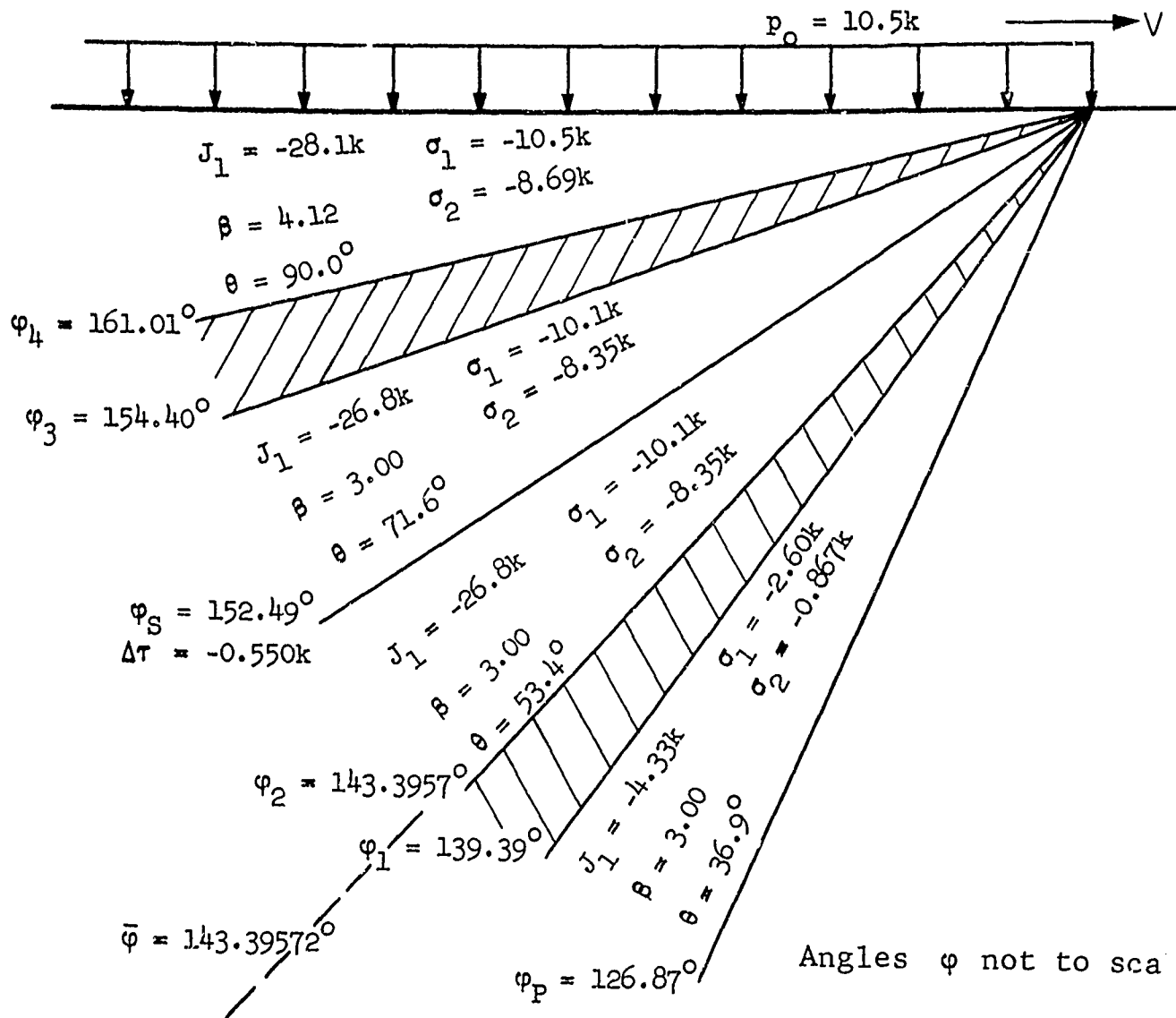

Fig. 14c

Result for $\nu = 0.25$, $V = 1.25 c_p$, $p_0 = 10.5k$

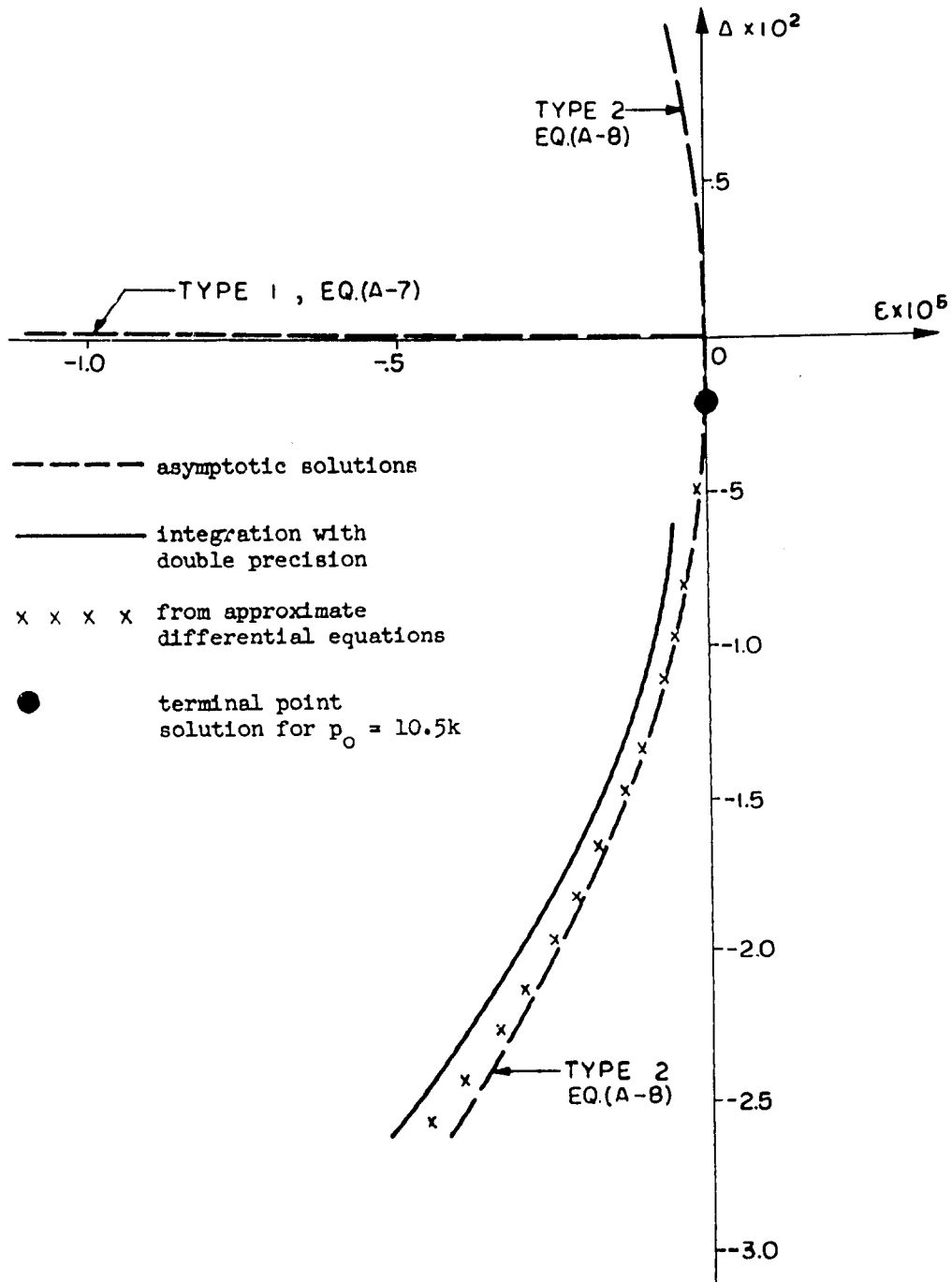

FIG. 15
 $\nu = 0.25, V/C_D = 1.25$

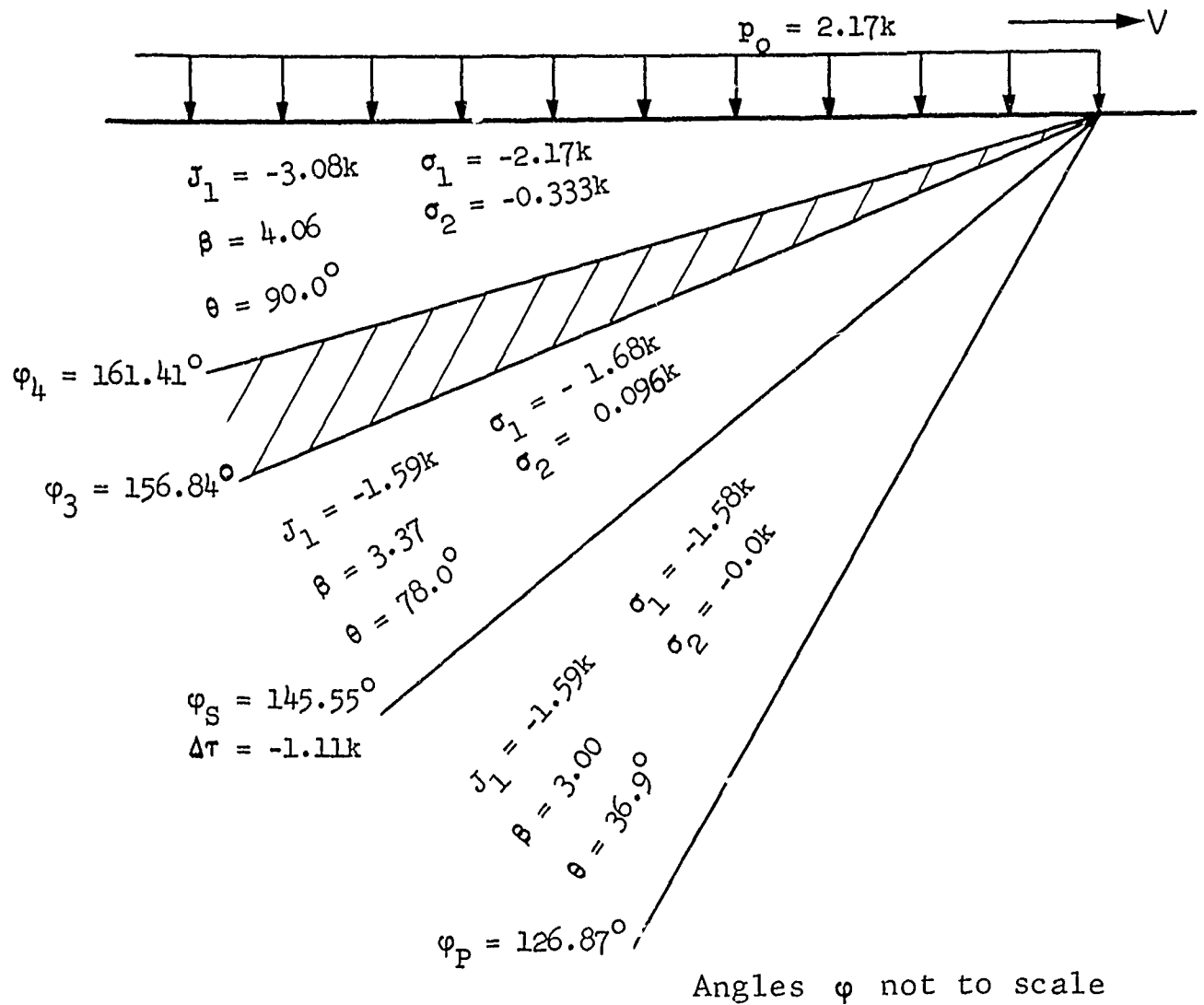
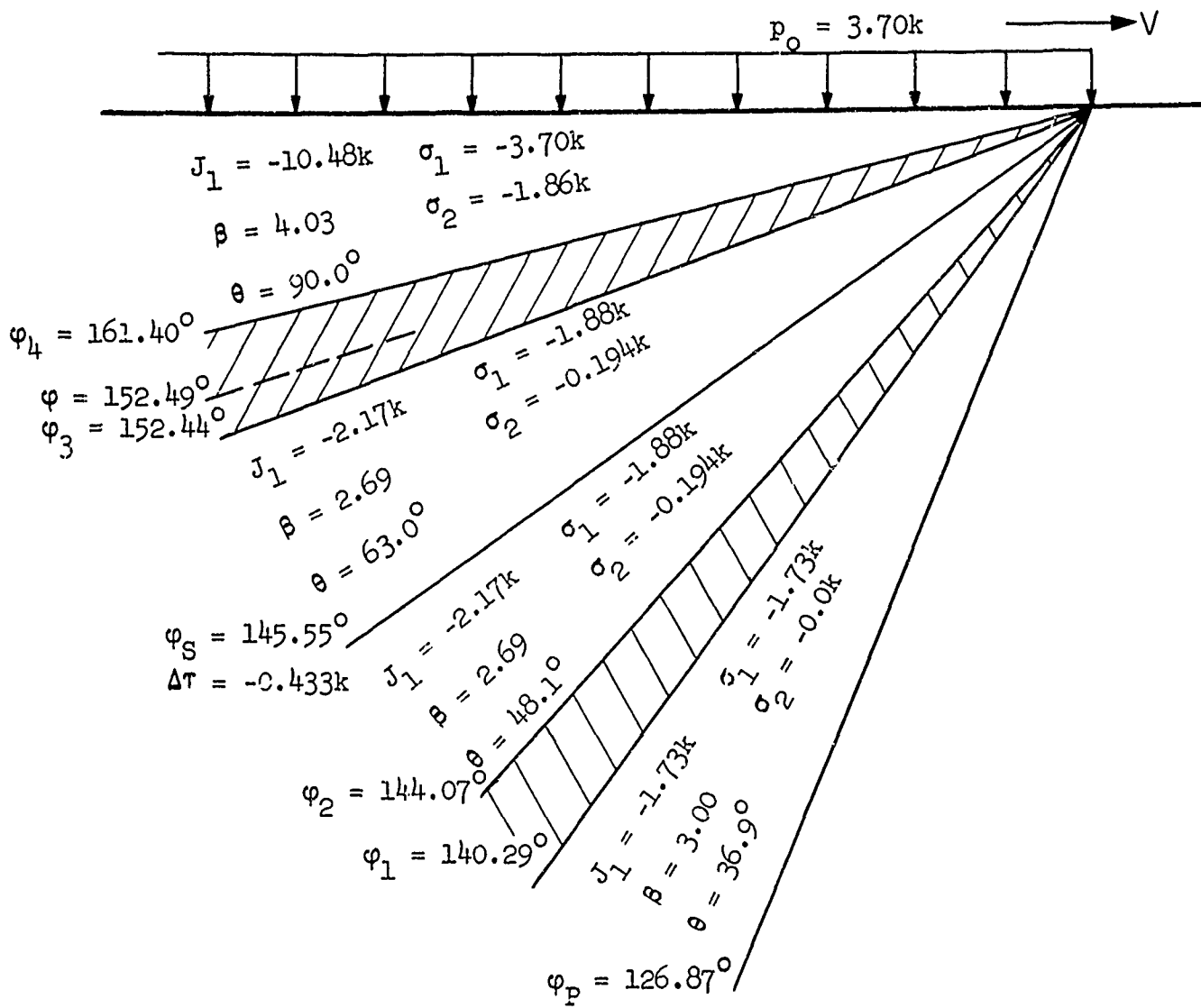

Fig. 16a

Result for $\nu = 0.$, $V = 1.25 c_p$, $p_o = 2.17k$



Angles ϕ not to scale

Fig. 16b

Result for $v = 0$, $V = 1.25 c_p$, $p_o = 3.70k$

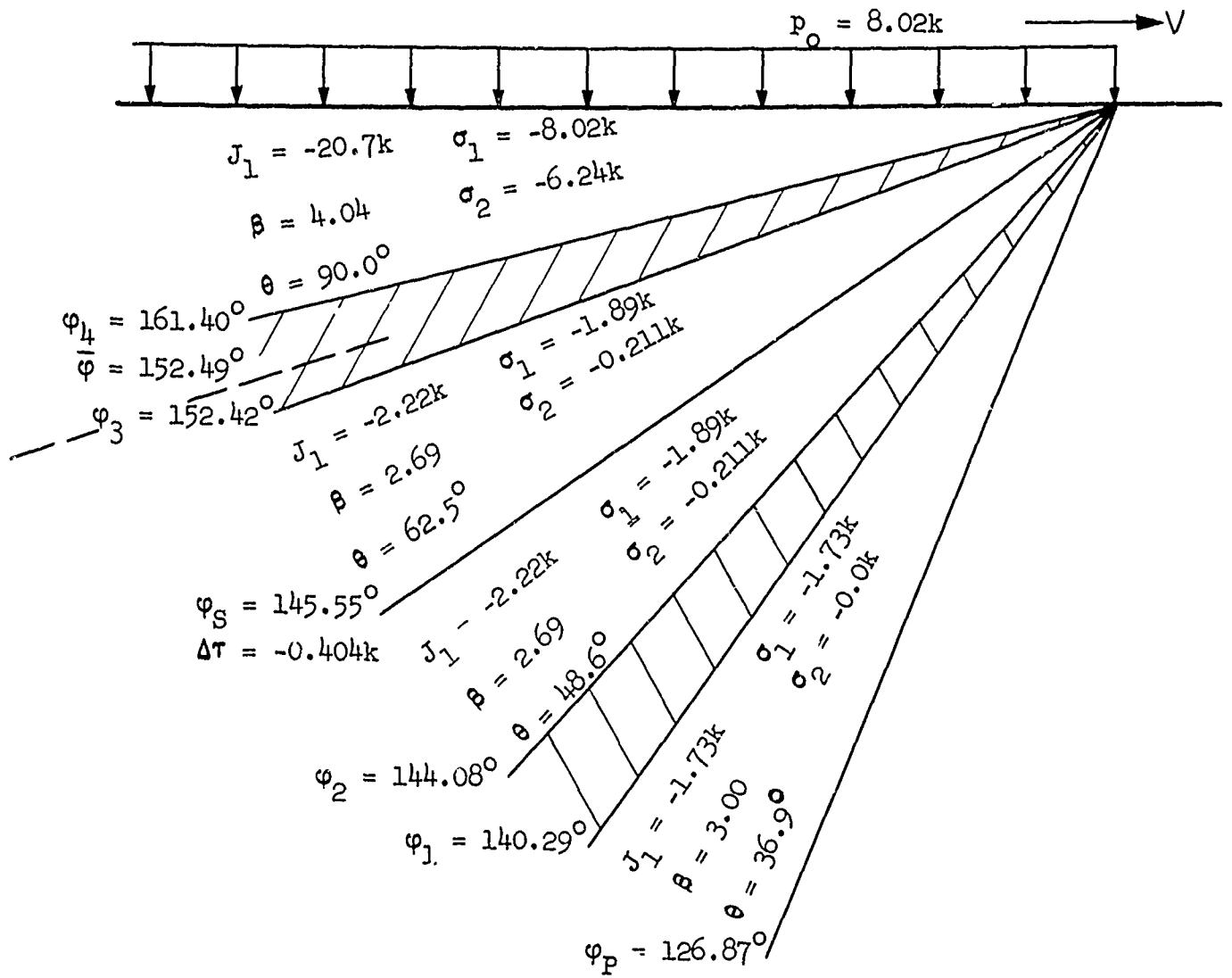

Angles ϕ not to scale

Fig. 16c

Result for $\nu = 0$, $V = 1.25 c_p$, $p_o = 8.02k$

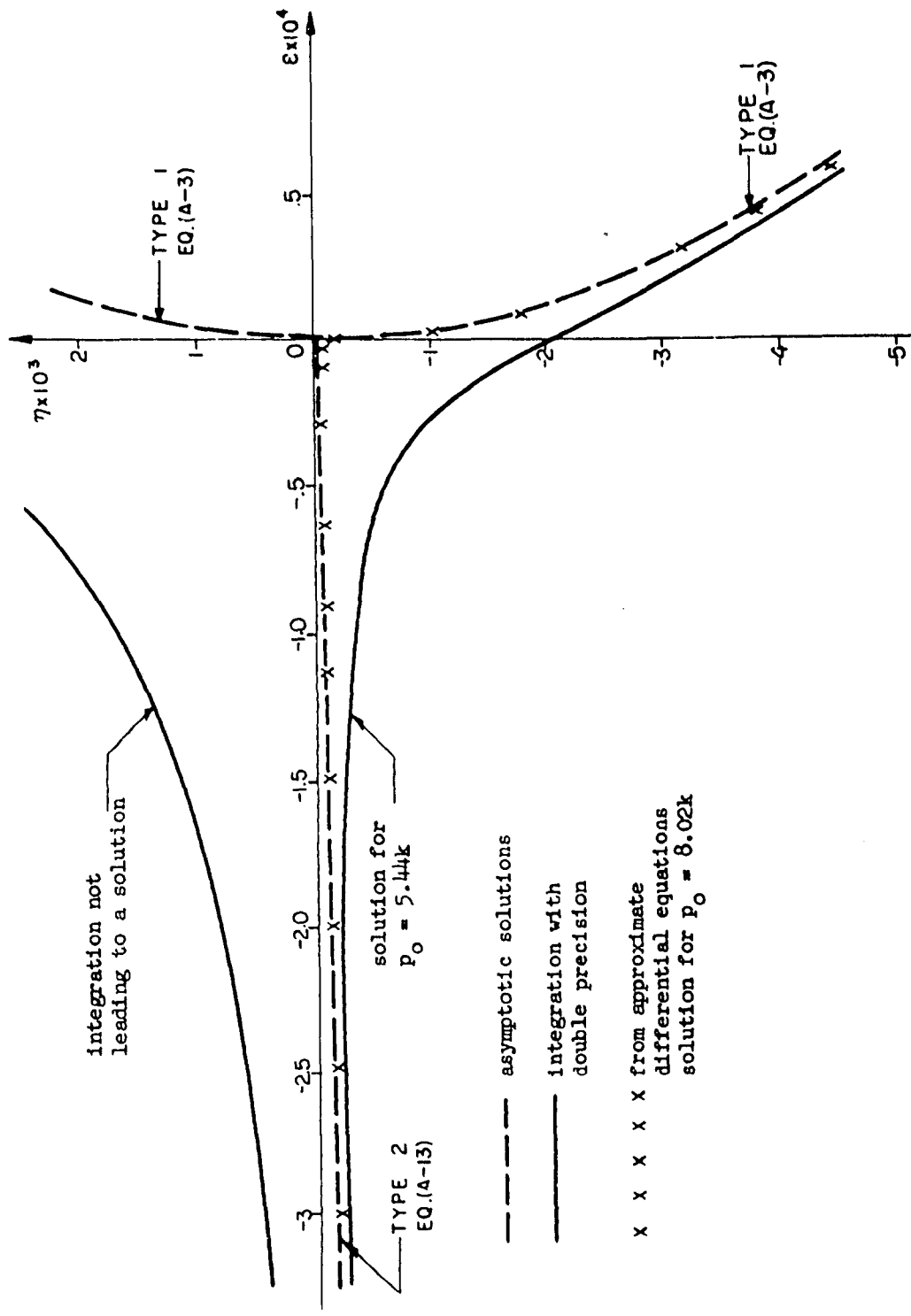

integration not leading to a solution

solution for $p_0 = 5.44k$

TYPE 2
EQ.(A-13)

TYPE 1
EQ.(A-3)

--- asymptotic solutions

— integration with double precision

· · · from approximate differential equations
solution for $p_0 = 8.02k$

FIG. 17
 $V=0, V=12.5 C_p$

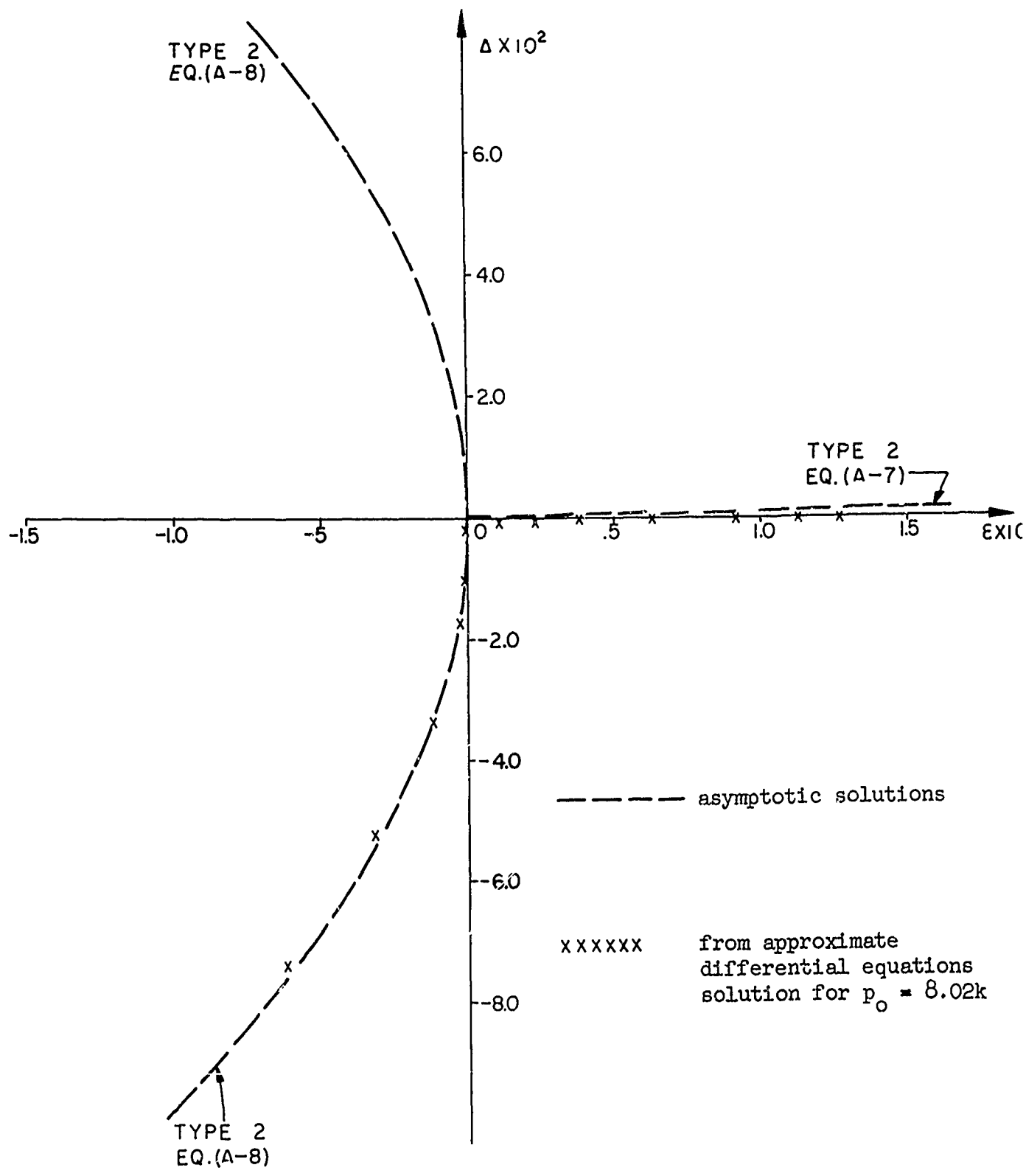

FIG. 18
 $\nu = 0, \nu = 1.25 C_p$

→ EX10⁴

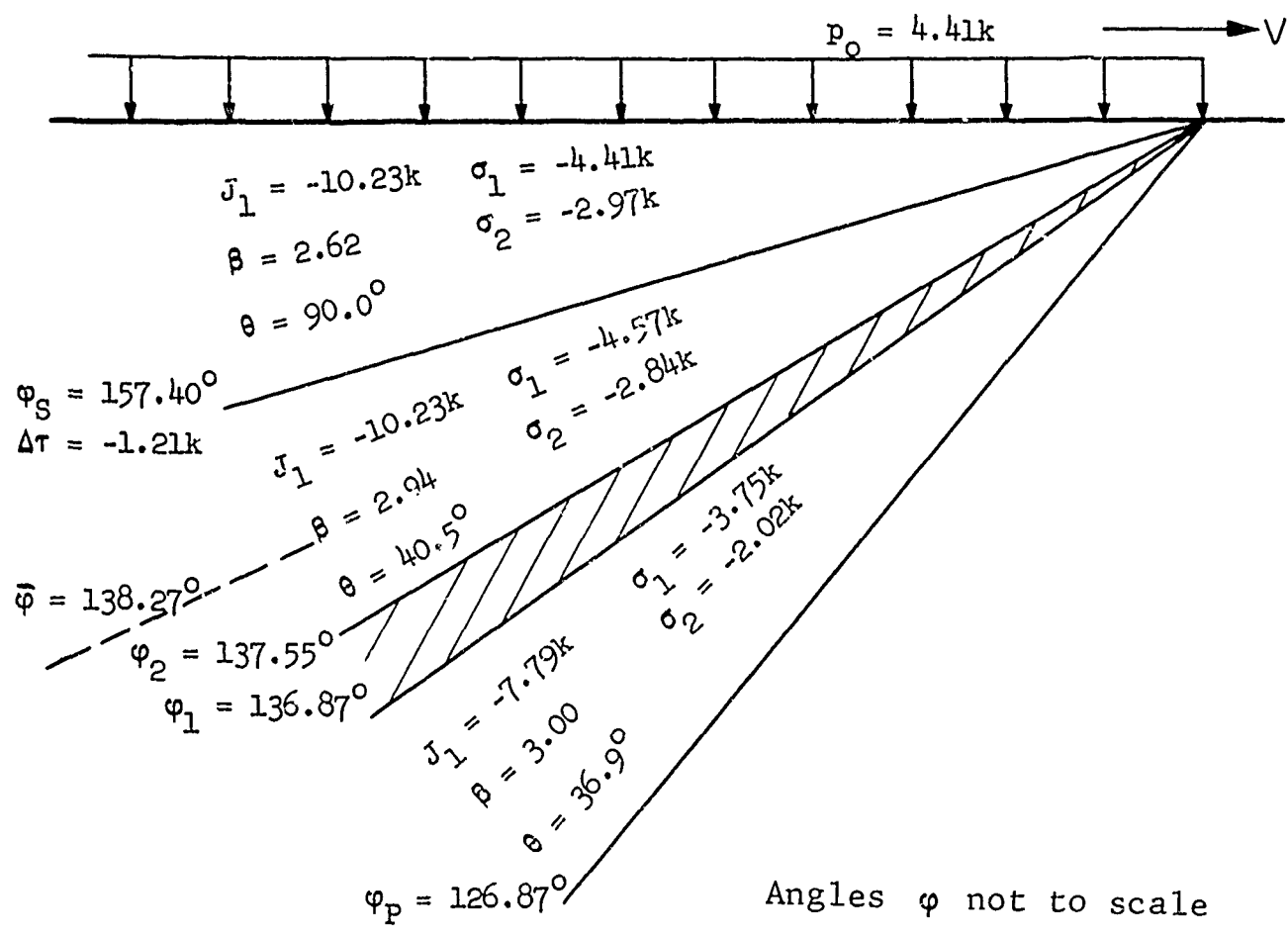

Fig. 19

Result for $\nu = 0.35$, $V = 1.25 c_p$, $p_0 = 4.41k$

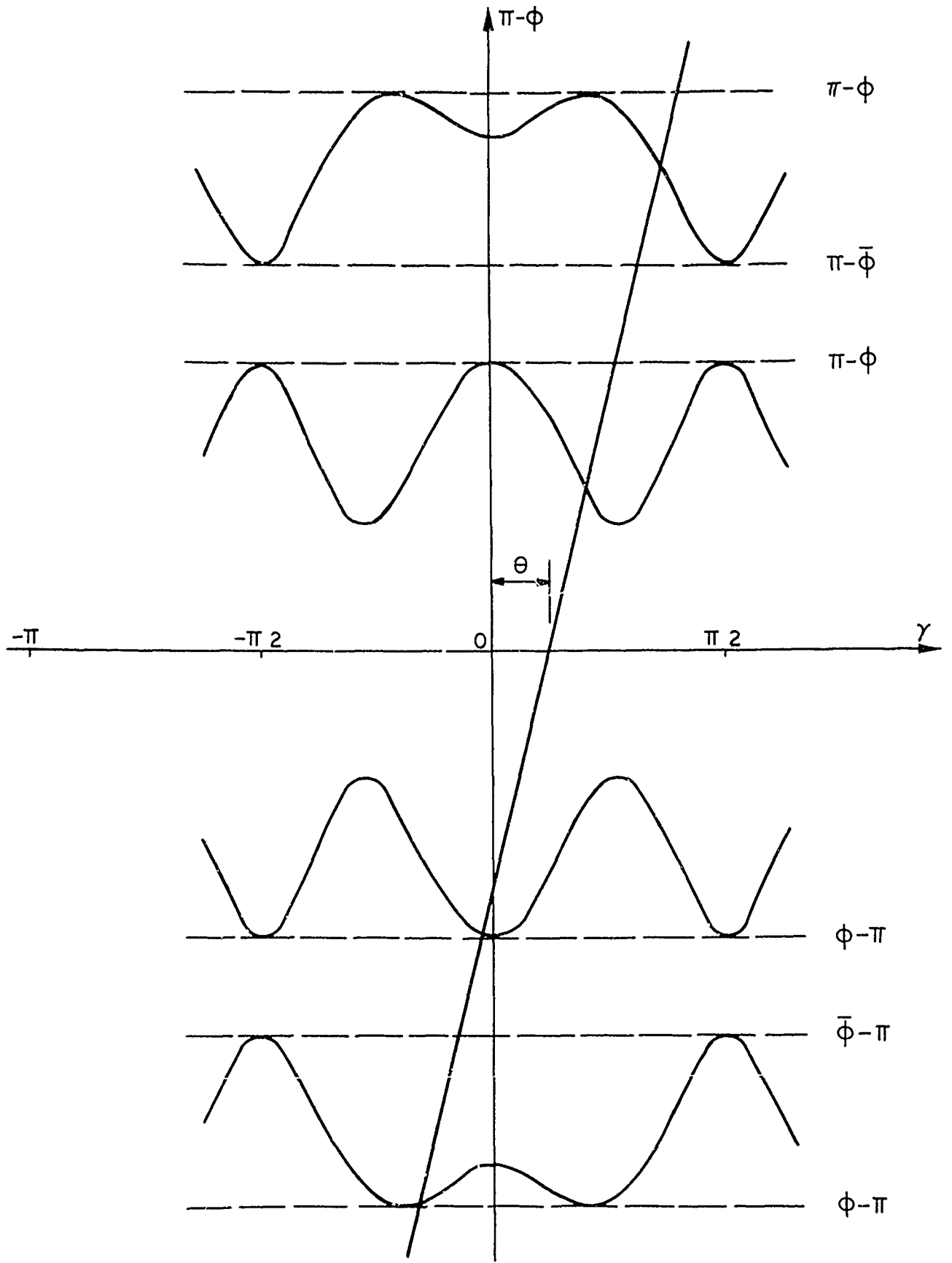

FIG. B-1

unclassified

Security Classification

DOCUMENT CONTROL DATA - R&D		
<i>(Security classification of title, body of abstract and indexing annotation must be entered when the overall report is classified)</i>		
1 ORIGINATING ACTIVITY (Corporate author) Columbia University		2a REPORT SECURITY CLASSIFICATION
		2b GROUP
3. REPORT TITLE Step Load Moving with Superseismic Velocity on the Surface of an Elastic-Plastic Half-Space		
4. DESCRIPTIVE NOTES (Type of report and Inclusive dates) Technical Report No. 38		
5. AUTHOR(S) (Last name, first name, initial) H. H. Bleich and A. T. Matthews		
6. REPORT DATE December 1965	7a. TOTAL NO. OF PAGES 115	7b. NO. OF REFS 1
8a. CONTRACT OR GRANT NO. Nonr 266(86)	9a. ORIGINATOR'S REPORT NUMBER(s)	
b. PROJECT NO. NR 064-428		
c.		
d.	9b. OTHER REPORT NO(S) (Any other numbers that may be assigned this report)	
10. AVAILABILITY/LIMITATION NOTICES		
11. SUPPLEMENTARY NOTES		12 SPONSORING MILITARY ACTIVITY Office of Naval Research
13. ABSTRACT <p>The plane strain problem of a step load moving with uniform superseismic velocity $V > c_p$ on the surface of a half-space is considered for an elastic-plastic material obeying the von Mises yield condition.</p> <p>Using dimensional analysis the governing quasi-linear partial differential equations are converted into ordinary nonlinear differential equations which are solved numerically using a digital computer. To overcome computing difficulties asymptotic solutions are derived in the vicinity of a singular point of the differential equations.</p> <p>Typical numerical results are presented for selected values of significant non-dimensional parameters, i.e. of the surface load p_0/k, of Poisson's ratio ν, and of the velocity ratio V/c_p.</p>		

Unclassified

Security Classification

14. KEY WORDS	LINK A		LINK B		LINK C	
	ROLE	WT	ROLE	WT	ROLE	WT
Wave propagation Elastic-plastic step load on half-space						

INSTRUCTIONS

- 1. ORIGINATING ACTIVITY. Enter the name and address of the contractor, subcontractor, grantee, Department of Defense activity or other organization (*corporate author*) issuing the report.
- 2. REPORT SECURITY CLASSIFICATION: Enter the overall security classification of the report. Indicate whether "Restricted Data" is included. Marking is to be in accordance with appropriate security regulations.
- 3. GROUP: Automatic downgrading is specified in DoD Directive S200.10 and Armed Forces Industrial Manual. Enter the group number. Also, when applicable, show that optional markings have been used for Group 3 and Group 4 as authorized.
- 4. REPORT TITLE: Enter the complete report title in all capital letters. Titles in all cases should be unclassified. If a meaningful title cannot be selected without classification, show title classification in all capitals in parenthesis immediately following the title.
- 5. DESCRIPTIVE NOTES: If appropriate, enter the type of report, e.g., interim, progress, summary, annual, or final. Give the inclusive dates when a specific reporting period is covered.
- 6. AUTHOR(S). Enter the name(s) of author(s) as shown on or in the report. Enter last name, first name, middle initial. If military, show rank and branch of service. The name of the principal author is an absolute minimum requirement.
- 7. REPORT DATE. Enter the date of the report as day, month, year, or month, year. If more than one date appears on the report, use date of publication.
- 8. TOTAL NUMBER OF PAGES: The total page count should follow normal pagination procedures, i.e., enter the number of pages containing information.
- 9. NUMBER OF REFERENCES: Enter the total number of references cited in the report.
- 10. CONTRACT OR GRANT NUMBER: If appropriate, enter the applicable number of the contract or grant under which the report was written.
- 11. PROJECT NUMBER: Enter the appropriate military department identification, such as project number, subproject number, system numbers, task number, etc.
- 12. ORIGINATOR'S REPORT NUMBER(S). Enter the official report number by which the document will be identified and controlled by the originating activity. This number must be unique to this report.
- 13. OTHER REPORT NUMBER(S): If the report has been assigned any other report numbers (*either by the originator or by the sponsor*), also enter this number(s).
- 14. AVAILABILITY/LIMITATION NOTICES: Enter any limitations on further dissemination of the report, other than those

imposed by security classification, using standard statements such as:

- (1) "Qualified requesters may obtain copies of this report from DDC."
- (2) "Foreign announcement and dissemination of this report by DDC is not authorized."
- (3) "U. S. Government agencies may obtain copies of this report directly from DDC. Other qualified DDC users shall request through _____."
- (4) "U. S. military agencies may obtain copies of this report directly from DDC. Other qualified users shall request through _____."
- (5) "All distribution of this report is controlled. Qualified DDC users shall request through _____."

If the report has been furnished to the Office of Technical Services, Department of Commerce, for sale to the public, indicate this fact and enter the price, if known.

11. SUPPLEMENTARY NOTES: Use for additional explanatory notes.

12. SPONSORING MILITARY ACTIVITY: Enter the name of the departmental project office or laboratory sponsoring (*paying for*) the research and development. Include address.

13. ABSTRACT: Enter an abstract giving a brief and factual summary of the document indicative of the report, even though it may also appear elsewhere in the body of the technical report. If additional space is required, a continuation sheet shall be attached.

It is highly desirable that the abstract of classified reports be unclassified. Each paragraph of the abstract shall end with an indication of the military security classification of the information in the paragraph, represented as (TS), (S), (C), or (U).

There is no limitation on the length of the abstract. However, the suggested length is from 150 to 225 words.

14. KEY WORDS: Key words are technically meaningful terms or short phrases that characterize a report and may be used as index entries for cataloging the report. Key words must be selected so that no security classification is required. Identifiers, such as equipment model designation, trade name, military project code name, geographic location, may be used as key words but will be followed by an indication of technical context. The assignment of links, roles, and weights is optional.