

ESD-TR-65-407
ESTI FILE COPY

ESD-TR-65-407

ESD RECORD COPY

REFUR TO
SCIENTIFIC & TECHNICAL INFORMATION DIVISION
(ESTI), BUILDING 1211

ESD ACCESSION LIST

ESTI Call No. AL 49152

Copy No. 1 of 1 sets

The MITRE Corporation



RESEARCH & EXPERIMENTATION 1960 - 1964

M65-1A

Distribution of this document
is unlimited.

ESR

AD627924

The work reported on in this document was sponsored in part by the Electronic Systems Division, Air Force Systems Command under contracts AF19(628)-2390 and AF33(600)-39852 and in part by the MITRE Independent Research Program.

The information in this document has been approved for public dissemination by the Directorate of Security Review, Department of Defense.

CONTENTS

I	INTRODUCTION	1
	CORPORATE HISTORY	
	TECHNICAL ORGANIZATION	
	RESEARCH AND EXPERIMENTATION AREAS	
II	SENSOR SYSTEMS	9
	RADAR SENSORS AND TECHNIQUES	
	Radar Interferometer Techniques; Two-Site Interferometer Program; Three-Site Interferometer Program; Analog and Digital Signal Processing Developments; Auxiliary Developments and Techniques; Microwave Devices	
	SENSORS FOR NUCLEAR DETECTION	
	OPTICAL TECHNOLOGY	
III	COMMUNICATIONS SYSTEMS	31
	EXPERIMENTS AND TESTS IN DIGITAL DATA TRANSMISSION	
	Competitive Digital Data Modems; Digital Data Transmission Over Switched Telephone Networks; AF Radio Data Transmission; UHF Air/Air Transmission; UHF Ground/Air Transmission	
	ANALYSIS OF OPTIMUM MODULATION TECHNIQUES	
	FLEXIBLE ERROR-CORRECTING CODER-DECODER	
	COMMUNICATIONS NETWORK SURVIVABILITY	
IV	ENVIRONMENTAL FACTORS	39
	TROPOSPHERIC PROPAGATION	
	LINE INTEGRAL REFRACTOMETER	
	FLAME PLASMA	
V	COMPUTER AND DISPLAY TECHNOLOGY	47
	THREE-DIMENSIONAL DISPLAY	
	COMPUTER DEVICE TECHNIQUES	
	Circuits and Circuit Components; High Speed Computer Memory; Optics and Electro-optics	
	PHOENIX GENERAL PURPOSE DIGITAL COMPUTER	
	Description; Development; Design Mechanization	

VI	SYSTEMS DESIGN LABORATORY	63
	HARDWARE	
	7030 (STRETCH) Computer; 1410 Computer; Analog Computer; SDL Display Consoles	
	SOFTWARE	
VII	INFORMATION PROCESSING TECHNIQUES	71
	DATA MANAGEMENT SYSTEMS	
	Experimental Transport Facility; COLINGO; ADAM; Time-Sharing Systems	
	PROCESSING TECHNIQUES	
	FAST; FORSIM IV; List Processing	
	RETRIEVAL SYSTEMS	
	Automatic Document Content Analysis and Retrieval; ROUT Document Retrieval System; Computer Processing of Logical Relations	
VIII	INFORMATION TRANSFER	89
	NATURAL LANGUAGE PROCESSING TECHNIQUES	
	INFORMATION DISPLAY	
	Display Legibility; Display Coding; Display/Control Relationship; Display Configuration; Display Design and Data Accessing	
IX	SYSTEM STUDIES	97
	COMMAND PLANNING	
	Role of the Commander; Planning Models; Analysis of Planning Structures and Procedures; Planning Concepts	
	AESOP	
	Development of On-Line Control Techniques for Operational Planning; Exercise and Evaluation; System Modeling - General War	
	LIFE SUPPORT	
X	MATHEMATICAL STUDIES	105
	TRAJECTORY ESTIMATION AND ERROR ANALYSIS	
	AEROSPACE COMMUNICATIONS FOR COMMAND AND CONTROL SYSTEMS	
	PERSPECTIVE PROJECTIONS	
	APPROXIMATION THEORY	
	GRAPH THEORY	
	A FAST MULTIPLIER	

I INTRODUCTION

The MITRE Corporation was established to provide a source of objective technical advice for United States Government agencies in the critical area of systems planning and engineering for information and communications systems. It furnishes a vital link between its sponsoring agencies and those scientific and industrial organizations that have a capability and interest in systems of this type.

The activities of MITRE in providing assistance in systems conception, definition, and acquisition require the knowledge and application of both basic and advanced aspects of science and technology. The effectiveness of any system will, in the long run, be determined by the level of the technical capabilities of the responsible organization. To maintain a high level of technical capabilities, and to advance the state-of-the-art, MITRE devotes a portion of its overall effort to research and experimentation. Although the investment in this effort is small when compared to the overall effort, its importance is far-reaching.

Participation in research and experimentation enables the scientist or engineer to develop more fully his understanding of the state-of-the-art and, perhaps, to advance it. Such participation strengthens his posture in the exchange of ideas with other technologists. It also equips him to meet the challenges at the leading edge of a rapidly evolving technology by exposing him to the constant stimulus of new ideas, the discipline of laboratory verification, and, above all, the testing of hypotheses against the trained judgment of other scientists and engineers.

The significant research and experimentation programs at MITRE from 1960 through 1964 are described in this document. Some of the technical work reported here results from direct support of systems engineering or systems planning projects, and some relates to research expected to have a broad application to existing problems or to the advancement of science and technology. Systems planning and engineering programs are reported in other documents.

The research and experimentation program is described in somewhat condensed fashion, but with sufficient technical depth to give the reader an appreciation of the scope, complexity, and value of the effort. It is not intended to be a complete report of MITRE research and experimentation: in order to present an overall view within a single document, technical details have been limited, extensive mathematical analyses briefly described, and classified aspects of the program omitted.

CORPORATE HISTORY

In August 1958, The MITRE Corporation was formed as an independent not-for-profit systems engineering firm. Initially, it provided technical support to the Air Force in the conception, design, integration, and acquisition of information, communications, and sensor systems for SAGE, the Semi-Automatic Ground Environment system.

SAGE is a computer-based air defense system for detecting, identifying, tracking, and controlling interception of aircraft threatening the North American continent. The Lincoln Laboratory of the Massachusetts Institute of Technology had

substantially completed the basic development of the SAGE system by 1957, but there still remained the systems management and systems engineering work, necessary to provide an operational system integrated with the new air defense weapons. Responsibility for the administrative supervision of this program was assigned by the Air Force to its newly created Air Defense Systems Integration Division (ADSID) in March 1958.

In searching for a technical support contractor, ADSID explored the conventional avenues, including academic organizations, industrial organizations, and combinations of the two. Of these, Lincoln Laboratory appeared to be a logical choice; it had carried the responsibility for the design of SAGE from its inception. The Air Force discussed this new assignment with MIT, but the Institute concluded that a long-term systems engineering task of this type was not appropriate for a university laboratory.

As an alternative, MIT proposed that Lincoln Laboratory undertake the work on a temporary basis, and that the Institute sponsor the formation of a not-for-profit corporation to take over the work, first under subcontract to Lincoln and later as an independent prime contractor. Ac-



The MITRE Corporation complex in Bedford, Massachusetts.

cordingly, The MITRE Corporation was formed, with a nucleus of scientists, engineers, and supporting personnel transferred from Lincoln Laboratory.

The first mission of the new organization was to integrate the SAGE system into the Continental Air Defense System. From this base, related work which might result from follow-on developments in air defense also was to be undertaken. The broadness of the base further permitted the Corporation to provide technical support in other areas of the overall defense effort. These activities included advanced planning and the creation of an adequate technology base for the design of newer large-scale air defense systems, such as the Back-Up Interceptor Control (BUIC) system and the North American Air Defense (NORAD) Combat Operations Center.

This trend was accelerated with the formation of the Command and Control Development Division (CCDD) of the Air Research and Development Command in 1959. CCDD not only took over the ADSID responsibilities, but was also given responsibility for the development of existing systems and the creation of new systems not in the air defense category. MITRE's proximity to Hanscom Field weighed heavily in the decision to establish CCDD at that facility, and MITRE became the principal technical support contractor for the new Division. In 1961, when the Electronic Systems Division (ESD) of the Air Force Systems Command was formed, and absorbed the functions of CCDD, MITRE became its technical support contractor.

Technical support activities for several major Air Force projects have included the establishment of operating centers away from Bedford, Massachusetts. MITRE has installed technical capabilities at:

Montgomery, Alabama, and Eglin Field, Florida, in support of the SAGE testing program;

Tampa, Florida, in support of the U.S. Strike Command, to assist in analyzing long-term requirements for an automatic command and control system;



Entrance to the Systems Design Laboratory located at L. G. Hanscom Field. The facility is operated by the MITRE Corporation for the Electronic Systems Division of the Air Force Systems Command.

Colorado Springs, Colorado, in support of the NORAD Combat Operations Center in developing a system for collecting, processing, and displaying data necessary for command and control of forces of the North American Air Defense Command in the event of a nuclear attack.

Sites have been or are being maintained in several New England areas in connection with experimental work on SAGE and other projects. In addition, Corporation personnel have conducted studies in, or have been sent as technical advisors to, Alaska, the Pacific, and South Africa, among other locations.

Because of MITRE's extensive experience in the development of air defense systems, the Department of Defense has called upon it to provide high-level technical assistance to United States



The Colorado Springs facility of The MITRE Corporation, located in the shadow of the Rocky Mountains.

missions that support our allies in developing and acquiring similar systems. Senior technical personnel participate with special task groups, composed of Defense Department and State Department representatives, making United States technical know-how available to allied nations. These groups have been working in:

Paris, in support of the North Atlantic Treaty Organization International Staff in preparing specifications and future plans for the NATO air defense systems;

Tokyo, in support of the U. S. Working Group cooperating with the Japanese Air Self-Defense Force in the planning and design of their Base Air Defense Ground Environment (BADGE) system;

Wiesbaden, in support of ESD's task of identifying and solving the problems connected with the installation of a semi-automatic system for air defense in West Germany, a task which was completed in July 1964.

Other Government agencies have engaged MITRE, from its inception, in various aspects of their work. One assignment has involved technical support in the development of an en route air traffic control system for the Federal Aviation Agency (FAA). Emphasis during the first three years was directed toward the design and implementation of an experimental high-altitude en route control system. Work was

centered at the Corporation's testbed in Bedford. In 1962, the testbed was converted to an all-altitude capability.

By April 1962, MITRE's work for the FAA had reached a level of significance that warranted the establishment of an Air Traffic Systems division. This division was moved to the Washington, D.C., area in June 1963 to work more closely with the FAA. Since then, its efforts have been directed toward systems engineering for the Air Traffic Control (ATC) subsystems of the future National Airspace System.

Shortly after this Washington group was established, the Department of Defense selected MITRE to assist the Defense Communications Agency in the design of the National Military Command System (NMCS). MITRE's work for the NMCS involves the design and integration aspects, and the communication between NMCS and various other command systems, including the World-Wide Military Command and Control System — a group of systems operated by



Washington, D.C., area office of The MITRE Corporation has been recently established in this Arlington, Virginia, building.

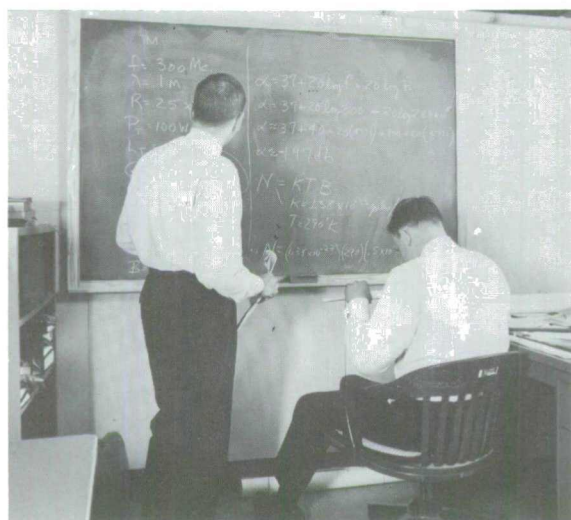
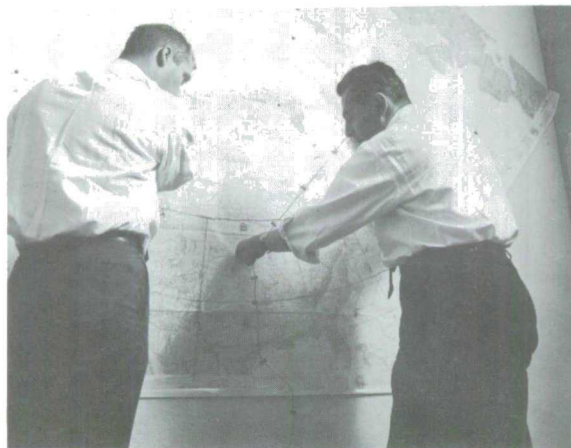
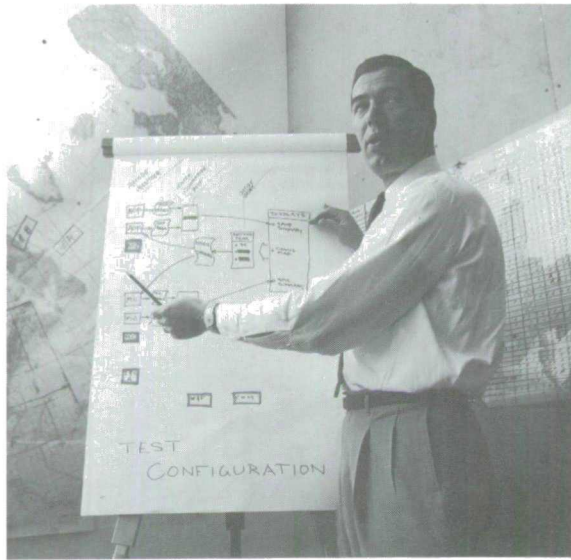

the unified and specified commands. This work made it necessary to establish another technical group in Washington in October 1963, and resulted in a new MITRE facility in Arlington, Virginia.

MITRE TECHNICAL ORGANIZATION

The MITRE Technical organization consists of six divisions: two for systems planning and engineering in specific non-ESD areas; one each for systems planning and systems engineering in support of ESD, and two to support the other four divisions by providing the technology base for the technical activities of the Corporation. It is within these latter two divisions — the Information Systems Laboratories and the Applied Science Laboratories — that the research and experimentation are centered. The other four divisions also contribute to the state-of-the-art, although the contributions are not their primary task.

Representative contributions to research and experimentation are reported in this document.

Within the divisions, the technical departments are engaged in specialties. Each technical activity conducted at MITRE results from some requirement or problem that needs to be solved in order to meet information and communication objectives.

Independent research work, although conducted within the individual technical departments, is selected and reviewed by the Research Council, which reports directly to the Vice President for Technical Operations. The cost of the independent research effort, funded by MITRE's fee, represents a small portion of the annual budget; the results, however, represent significant contributions to the scientific, industrial, and military communities as a whole.

RESEARCH AND EXPERIMENTATION AREAS

In this report, the research and experimentation activities are divided into nine technological areas:

- Sensor Systems
- Communications Systems
- Environmental Factors

The MITRE Corporation Technical Organization

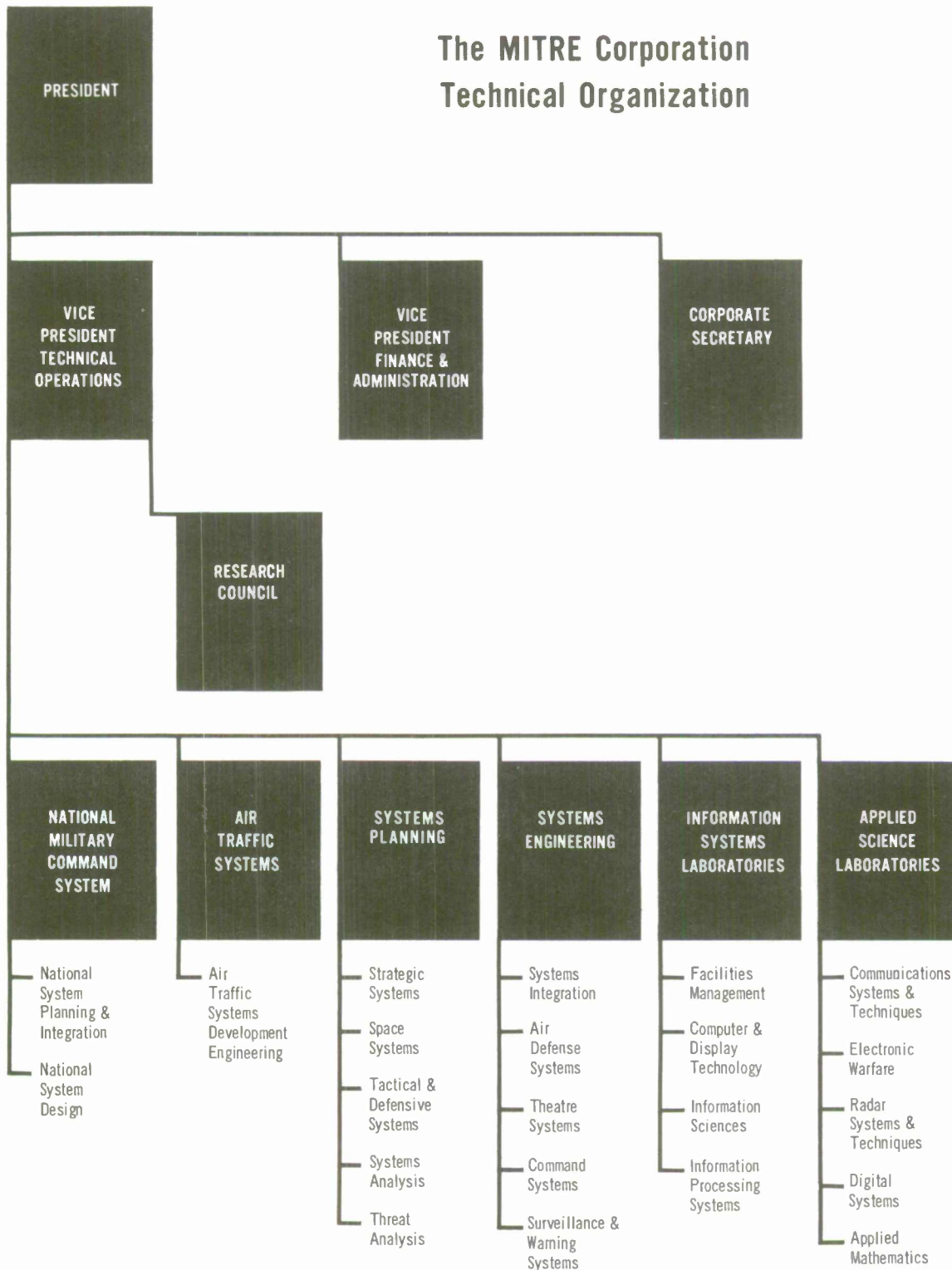

Computer and Display Technology
Systems Design Laboratory
Information Processing Techniques
Information Transfer
Systems Studies
Mathematical Studies

MITRE is organized to meet the needs of information and communication systems; many of its departments therefore have overlapping interests in specific technological areas. These areas, in which knowledge of the state-of-the-art is of direct concern, range from the sensors which receive the signals, to the communicating of these signals through their environment, to the data processing of the information, to the transfer of the information to man, and to man's interaction with the system.

In an operating system, the flow and processing of information from the individual areas interact

in a complex manner. Research into the complexities of these interactions is an essential area of study in itself. In the Systems Design Laboratory, operated by the Information Systems Laboratories Division, prototype and experimental information and communications systems are modeled for real-time simulation of interaction problems.

The activities of the research and experimentation program have led to Government-sponsored projects and patent applications. Other ideas, not immediately suitable for support under direct contract, but which show promise of future application within MITRE's mission, are investigated through this program. The activities represents a genuine contribution to the solution of problems in critical areas of information-and-communication technology, and, simultaneously, improves MITRE capability as a technical consultant.

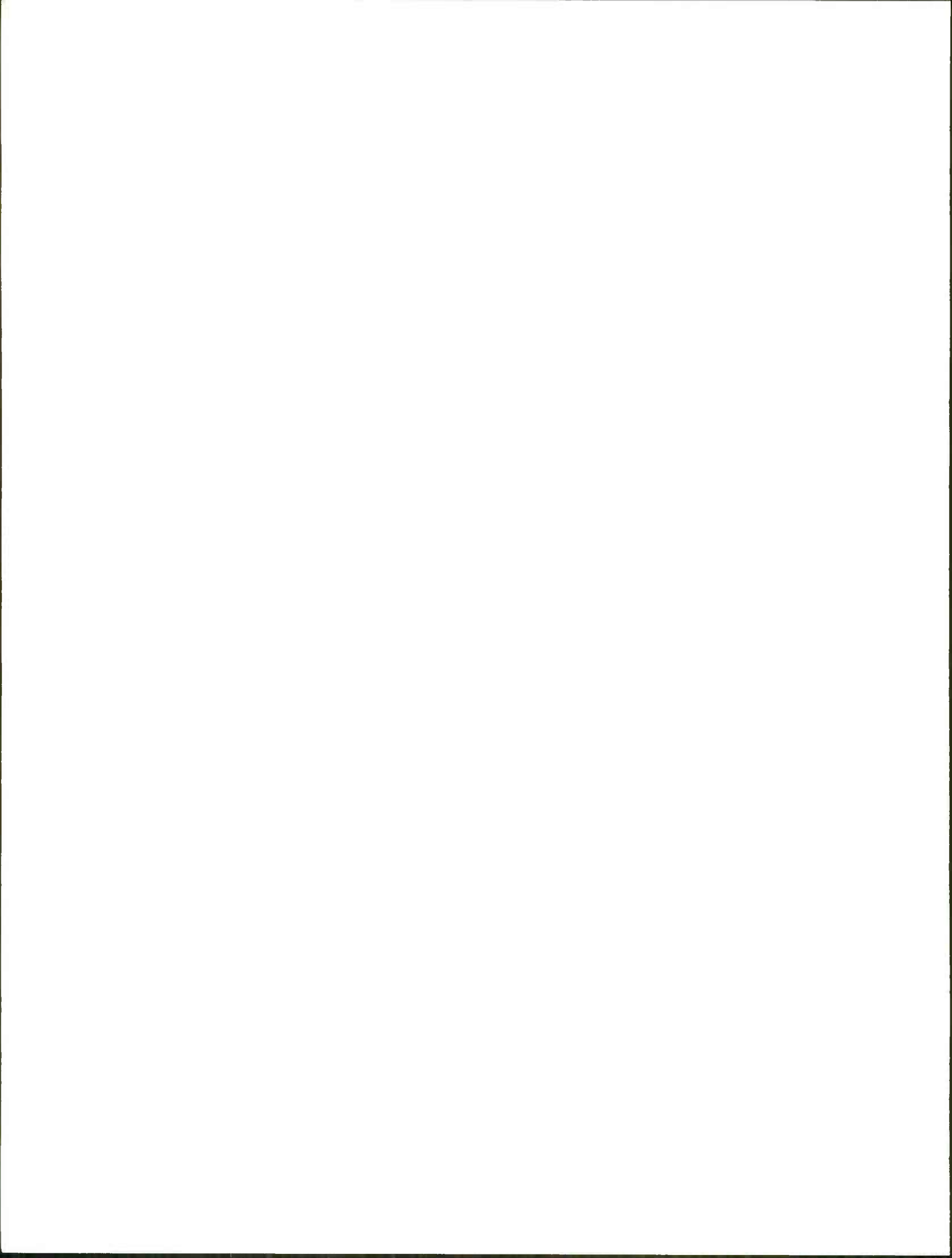

II SENSOR SYSTEM TECHNIQUES

A thorough, up-to-date knowledge of the technology of systems elements is vital in the design and acquisition of information and communication systems. Of these elements, sensors are particularly important because, through the processes of detection, identification, and measurement, they provide the systems with fundamental input data. Consequently, new sensor techniques must be continually investigated for their impact on systems design. The sensor research and experimentation efforts at MITRE are specifically addressed to those problem areas which are critical to information and communication systems.

The tremendous progress in computational technology has been one of the most important stimuli to the achievement of newer sensor systems. In fact, individual radar sensors can now be interconnected through common data processing facilities, resulting in vastly increased capabilities for accurately determining the location of aircraft, satellites, and ballistic missiles. Similarly, single optical sensors can be combined to produce nationwide nuclear-explosion locating systems.

Investigations at MITRE have included work in the areas of radar sensors and techniques, laser techniques, and sensors for the detection and location of nuclear detonations.

RADAR SENSORS AND TECHNIQUES RADAR INTERFEROMETER TECHNIQUES

One of the major sensor problems encountered today is the precise determination of the trajectories of ballistic missiles and satellites. The radar interferometer is a means of accurately determining such trajectories as well as the effects of the troposphere and the ionosphere on radar measurements. The MITRE program has been established to determine the ultimate limitations of radar interferometry measurements set by propagation characteristics, component instabilities, and target scintillation characteristics.

The present radar facility at MITRE began as part of a long-term, applied research and experimentation program in radar, communications, signal processing, and related sensor techniques. It

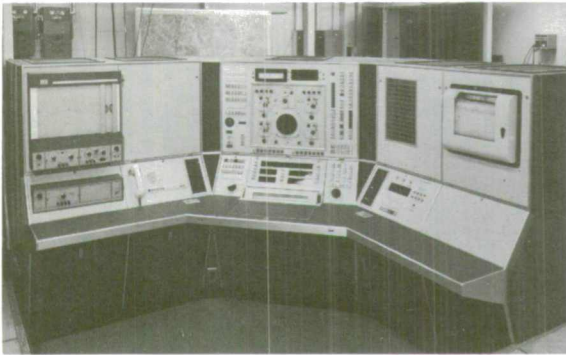

Centralized control of the operation of the MITRE radar interferometer is performed at the Radar Console located at the Bedford Site.

has served as a versatile testbed for the evaluation of many of the advanced radar concepts arising in this program. The results of this research and experimentation have led to system development programs of which the interferometer systems to be described are examples.

The radar interferometer has the distinct advantage that it can measure accurately and quickly not only the target position and radial velocity, but also the components of velocity which are perpendicular to the radar line-of-sight. The two-site interferometer, consisting of a radar transmitter and receiver plus another receiver remotely located, utilizes a comparison of the phase difference of the signals received at the two separated receivers. The baseline separation between the receivers must be large compared to the antenna diameter, but not so large that it introduces a serious parallax problem at the target ranges of interest. The rate-of-change of phase difference between the two received signals provides an extremely accurate measurement of angular rate, which, when multiplied by the target range gives the component of velocity perpendicular to the radar line-of-sight and lying in the plane of the target and the two receivers. In order to measure both components of transverse velocity, a three-site system employing at least three receiver sites is needed with one of the receiver sites common to the two baselines.

The Two-Site Interferometer Program

The two-site interferometer development at MITRE extended earlier efforts to L-band frequencies, provided improvements in the phase stability of the equipment, and refined and greatly expanded the techniques for signal and data processing. This two-site system comprises a transmitter, receiver, and data processing equipment in the MITRE complex at Bedford, Massachusetts; a slaved, passive-receiver site at Boston Hill in North Andover, Massachusetts; and a microwave data link interconnecting both sites. The system has been in operation since April 1963. The coherent, interferometer baseline is 10.5 nautical miles which is approximately 10^5 wavelengths. A linear, frequency-modulated, pulse-compression system with a bandwidth of one-megacycle per second and a compression ratio of 1000 was successfully tested with the two-site system in October 1963. This development has served as a testbed for the evaluation of microwave and signal processing techniques as well as a tool for the experimental evaluation of pulse interferometry.

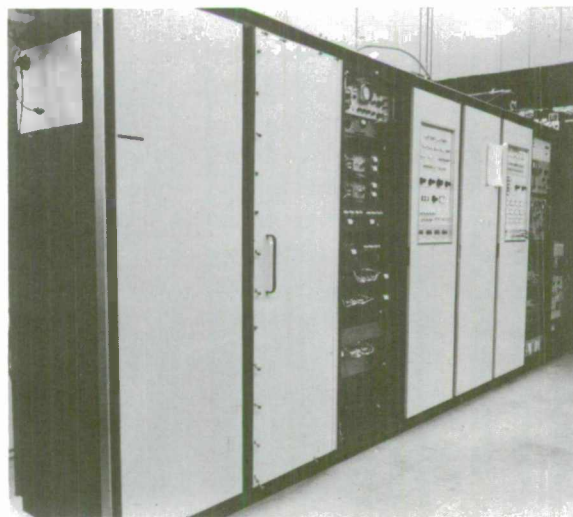

A typical view of the interior equipment installations of the MITRE interferometer system is provided by the radar exciter, receiver, and sequential doppler processor shown above at the Bedford Site.



The space-frame radome of the Bedford interferometer site houses the steerable radar antenna which both transmits and receives for two-site interferometry. For three-site interferometry the antenna receives radar returns from the Millstone Hill radar transmitter. In the background is the antenna tower for the microwave link which is used for synchronization of the three radar sites and for centralized collection of the radar returns.

The 30-foot parabolic antennas at each site are enclosed by 48-foot, space-frame radomes; each antenna is provided with dual-polarization feed structures. The system is operated at a peak power level of 320 kilowatts with a nominal pulse-width of one millisecond and a repetition frequency of 30 pulses per second. A multiple-repetition-rate capability permits velocity ambiguities to be completely resolved.

The system has excellent phase stability. Recent measurements made over a three-second interval showed a short-term, residual phase variation about the best-fitting polynomial of 2.5° rms at the MITRE E-Site and 5.0° rms for the signal received over the microwave link from Boston Hill. These phase residuals include contributions

from system phase instabilities, target scintillations, and atmospheric propagation. At the 1280-mc operating frequency, these phase errors correspond to fine range variations of 2.5×10^{-3} ft rms for the Bedford site and 5×10^{-3} ft rms for the Boston Hill site.

Three-Site Interferometer Program

In August 1963, a major effort was made to expedite the early completion of an operational, three-site interferometer radar which could be used to obtain precision trajectory measurements. Negotiations were undertaken with the Lincoln Laboratory to reach an agreement whereby the Lincoln Millstone Hill Radar could be tied in with the MITRE system. The tie-in was completed in June 1964, and tristatic operations have been in effect since that time.

In the tristatic configuration, with the Lincoln Laboratory Millstone Hill Radar comprising the third site, the target illumination is provided by the Millstone Hill transmitter as shown in the accompanying block diagram. The MITRE antennas at Bedford and Boston Hill are slaved to the Millstone antenna, an 84-foot parabola which uses a 12-horn monopulse system to track the target. The operation of the system is completely coherent with all local-oscillator frequencies as well as the transmitted frequency derived from one, extremely-stable frequency standard. This system operates at 1295 mc at a peak power of 5 megawatts with a nominal pulse length of one millisecond and a repetition frequency of 30 pulses per second. The length of the interferometer baseline from Bedford to Millstone Hill is 13.2 nautical miles, and the baseline from Millstone Hill to Boston Hill is 17.6 nautical miles in length.

The signals received at Millstone Hill and Boston Hill are transmitted by microwave link to Bedford where they are time-multiplexed with the Bedford receiver output and applied to a sequential doppler processor. This device preprocesses the return signals in sequence and records the radar parameters on magnetic tape for subsequent off-line computer processing. The para-

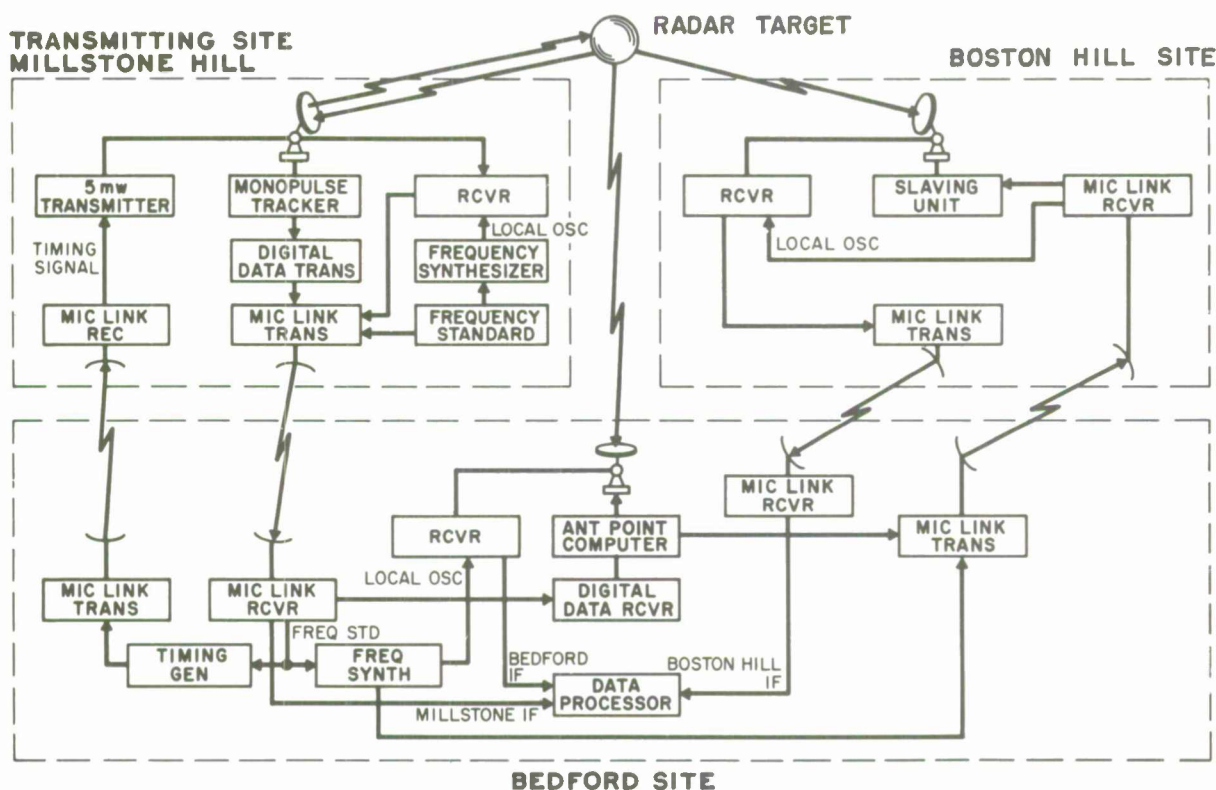

The MITRE three-site interferometer. The reflections from the target which is illuminated by the Millstone Hill radar are received at all three sites. Centralized signal processing and synchronized operation is performed at Bedford by use of the interconnecting microwave links.

meters recorded are the main-bang time, antenna angular position, radar range to the target, coarse filterbank number of the sequential doppler processor, fine-frequency integrator outputs, and signal amplitude.

Modifications are currently underway to connect the radar outputs directly to an on-line, real-time computer. A Scientific Data Systems Model 930 has been procured and installed for this purpose. It has a 24,000-word memory, a 24-bit word capability, and a one-microsecond cycle time. Peripheral equipment includes a 300-line-per-minute line printer, a 60,000-character/second IBM compatible tape unit, MAGPAK, 100 card/minute card reader, and an input-output typewriter.

ANALOG AND DIGITAL SIGNAL PROCESSING DEVELOPMENTS

The Sequential Doppler Processor

A sequential doppler processor has been developed and installed in the three-site interferometer system. In this application, the unit processes the time-multiplexed output data of the three receiver sites. This processor was required because the accuracy of the measurement of the radial velocity of a target by radar is directly proportional to the effective time duration of the received signal, provided that full use has been made of the received information with the aid of coherent signal processing during this time interval.

Conventional techniques which restrict the period of coherent processing to that of a single pulse, for which one millisecond is a typical time duration, have a relatively low accuracy in this respect. The problem of improving such low accuracies by a factor of 1000, for example, would require that the signal processing time be extended to the order of seconds. Since the radial velocity is proportional to the time rate-of-change of phase, the problem is equivalent to that of measuring signal phase variations with respect to a local oscillator reference over this extended period, a measurement which is made difficult by the following factors:

Large phase variations can occur during each pulse.

The gross motion of the target can produce large phase variations from pulse-to-pulse to the extent of millions of degrees.

The use of pulse measurements can produce phase rate ambiguities.

Extraneous phase variations can be introduced by equipment instabilities, atmospheric propagation, and target rotation.

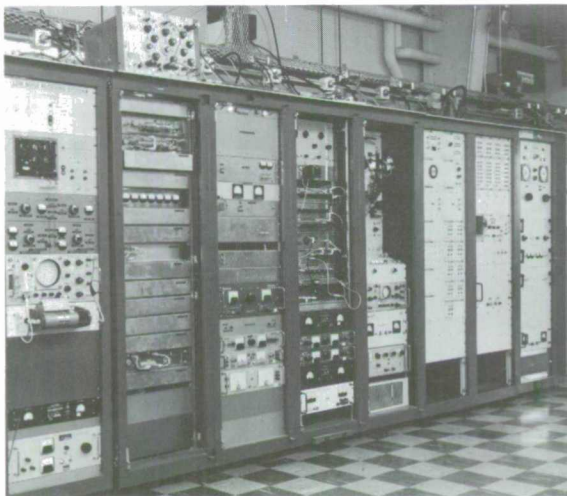

Pictured above is the interior radar equipment at the Boston Hill Site of the MITRE Interferometer. This receiving site, 10.5 nautical miles from the Bedford Site, is slaved to the rest of the system via microwave link.

This processor extracts signal phase from uncoded radar pulse returns on a pulse-by-pulse basis. The basic functions of the processor are pulse detection and the measurements of pulse amplitude, coarse range, coarse velocity, and signal phase. The heart of this processor is a fine filter bank consisting of eight pairs of gated quadrature integrating filters which provide a frequency-domain implementation of the time-domain sampling theorem on the received signal. The digitized outputs from this fine filter bank, together with the coarse frequency and range, constitute the data necessary for the extraction of the phase. The necessary computations are performed by a digital computer. The computer programs required for the preliminary data analysis have been written and checked.

Many experiments have shown that the rms contributions of the radar equipment and the computer programs to the measurement errors are of the order of a few degrees of phase for observation periods of several minutes. The data available as a result of measurement on each transmitted pulse are ambiguous, modulo 2π . In addition, an unknown bias error is included in the output. However, the bias errors are known to be constant to within a few degrees for periods of several minutes. This permits very accurate measurements to be made of the change in phase during a typical measurement. Although the phase measurements were made with a pulse-radar system, thus rendering ambiguous the change in phase relationships also, it was found that such ambiguities can be resolved with complete confidence for observation periods of several seconds. The processor also has a multiple, pulse-repetition-rate capability which provides resolution of velocity ambiguities.

The Binary-Delay-And-Heterodyne Filter

The binary-delay-and heterodyne filter is a radar spectrum analyzer recently developed at MITRE to process uncoded, radar-pulse returns from a multiplicity of targets having Doppler fre-

quencies up to 256 kc. The concepts used in the design have led to extraordinary simplification in implementation without compromise of performance. The spectrum analyzer is equivalent to a bank of 256 filters, each matched to the waveform of a single radar pulse of one millisecond time-duration, and it possesses multiple, pulse-repetition-rate capability.

The complexity of implementing directly a filter bank containing such a large number of filters has led in the past to the conventional technique of utilizing multiple recirculations through a delay line with frequency translations. This technique

invariably results in severe problems of tolerance which, in turn, limits practically the number of recirculations.

The binary-delay-and-heterodyne filter escapes the tolerance problem by eliminating the recirculations. Instead, the received signal pulse is passed down a binary ladder of eight delay lines, each having a frequency translation associated with it. In addition to avoiding the tolerance problem, the bandwidth of the analyzer is a small fraction of that required for more conventional analyzers.

Since the analyzer not only detects the received signal but also measures the signal phase, it could be used with the MITRE interferometer in much the same manner as the sequential doppler processor.

The CAVORT Signal Processing System

The CAVORT system is another type of spectrum analyzer developed at MITRE. The acronym was chosen from its function: *coherent acceleration and velocity observations in real time*. This

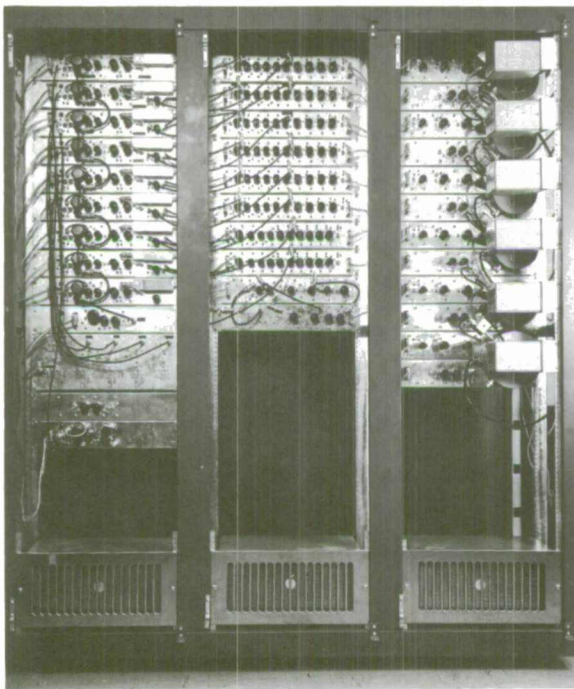

The binary-delay-and-heterodyne filter is a radar spectrum analyzer which processes multiple target data obtained from uncoded pulse radar systems. The analyzer is equivalent to a bank of 256 filters. It utilizes techniques that avoid the complexity and tolerance problems of conventional methods of recirculating data through delay lines.

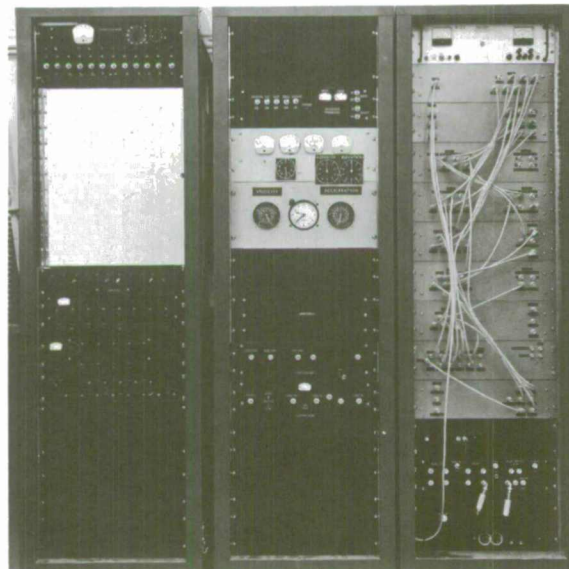

The CAVORT System is a radar spectrum analyzer which processes target data obtained from uncoded pulse radar systems and displays the radial velocity and acceleration in real-time using technique which avoid computer processing.

analyzer is used to process uncoded, radar-pulse returns from a single target in such a manner as to display direct measurement in real time of the radial velocity and acceleration of the target without computer processing of the data. Its response is matched to the waveform of a sequence of twelve, uniformly-spaced radar pulses. It provides coherent integration of the sequence even under the condition of large radial acceleration of the target. Since integration or summation of the 12 pulses is required, the analyzer utilizes a fixed, pulse-repetition rate.

The heart of the analyzer is a quartz delay line having an exceptionally long delay of 10 milliseconds. It is used in a closed loop which employs multiple recirculations with frequency translations. It is capable of nearly ideal performance for integration intervals as long as one-half of a second, which, by comparison, is an interval sufficiently long enough to render useless a conventional velocity-only integrator. It can utilize the coarse output data of the sequential doppler processor in order to follow large doppler shifts which would otherwise fall outside of its range. This analyzer is most useful for single radar sites.

The data provided by this analyzer has been found to be in excellent agreement with data acquired by other methods which require computer processing of the data.

The 1000:1 Linear-FM, Pulse-Compression System

The choice of the particular waveform used for transmission in a radar system is dependent upon many variables and probably no one waveform is optimum for all requirements. However, the linear-FM, frequency-ramp waveform possesses a set of advantages which make it clearly superior for many present-day radar problems. First, the transmitted envelope is rectangular, implying optimum use of the transmitter power and insensitivity to limiting and other nonlinear operations. Second, the transmitted spectrum is also rectangular, easing bandwidth requirements and maximizing performance where clutter rejection is desired. Third, its ambiguity function is so structured as to permit a single, pulse-compres-

sion system to perform both range and velocity measurements in matched-filter fashion, and to avoid the requirement of *a priori* knowledge of velocity. Fourth, the ambiguity diagram for linear-FM waveforms is well-behaved as a function of velocity, and the theoretical problem of designing a mismatched filter to reduce the side-lobes has been solved in a satisfactory manner. The linear-FM waveform has other advantages as well, and for many applications the disadvantages usually associated with this specific signal can be bypassed, either by clever use of the parameters of the system or as a natural result of the target situation.

An important aspect of receiver design is the degree to which the matched filter concept is implemented. It is possible to match a received signal under stringent, restrictive conditions; e.g., it may be required that the Doppler frequency corresponding to the velocity of the target be known accurately, in order to effect a complete match. A much more general approach is to implement matched filters which are truly linear, time-invariant devices, such as a simple passive filter. If this can be accomplished, then no *a priori* knowledge of the target parameters is required.

The second and more general approach was employed in the 1000:1 linear-FM, pulse-compression system developed at MITRE. The transmitted waveform of this system is roughly rectangular in shape with a bandwidth of one-megacycle per second, and a duration of one millisecond. Consequently, the output of the matched filter receiver has the shape of the function $(\sin x)/x$, before sidelobe reduction, with a duration of about two microseconds from null to null. The parameters are thus directly compatible with long-pulse radars. The system contains both allpass networks and quartz delay lines. Ten channels, each controlling one-tenth of the output waveform are arranged in the form of a tapped delay line with one dispersive network connected to each tape.

The pulse-compression technique developed possesses a number of important advantages: (1) It is capable of linearly generating and proc-

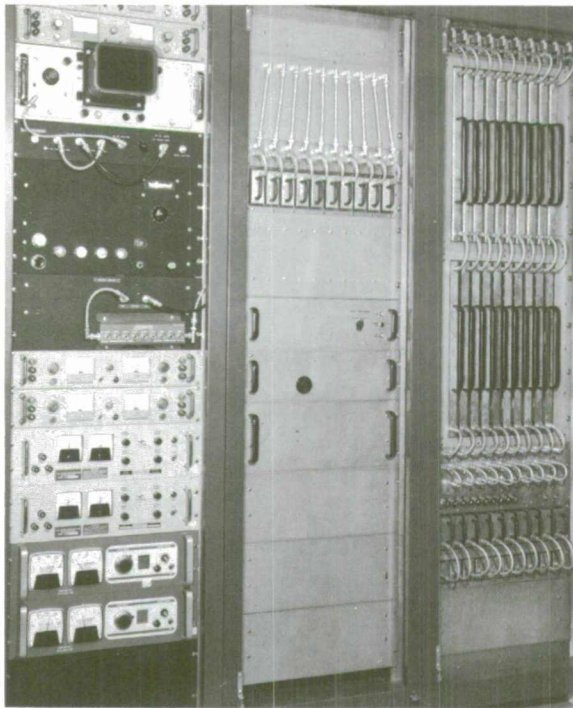

essing waveforms having very large, time-bandwidth products, (2) the design approach results in a matched-filter output which has very low range sidelobes, (3) the ambiguity function of its output waveform is well-behaved, even for large Doppler shifts, (4) it is simple to adjust and align, and (5) the technique can be easily extended to larger, time-bandwidth products. Furthermore, linear-FM coding facilitates the direct measurement of Doppler frequency, and provides a pair of waveforms which may be used to remove range ambiguities. This procedure eliminates the need for a large number of Doppler filters. The experimental version of the system has established that the synthesis technique is practical and straightforward to implement.

The 1000:1 Linear-FM Pulse Compression System was successfully tested with the MITRE two-site interferometer in October 1963.

The 10,000:1 Linear-FM, Pulse Compression System

A 10,000:1 linear-FM, pulse-compression system presently under construction at MITRE possesses the same advantage as the 1000:1 system previously discussed. Namely, it improves range resolution and eases the power limitations of conventional radars, permits matched-filter measurements of Doppler frequency, possesses good side-lobe control over a relatively wide Doppler frequency band, and confers important anti-jam benefits to operational radars. Its use with the experimental radar will yield a range resolution of 100 feet with a transmitted pulse-length of two milliseconds.

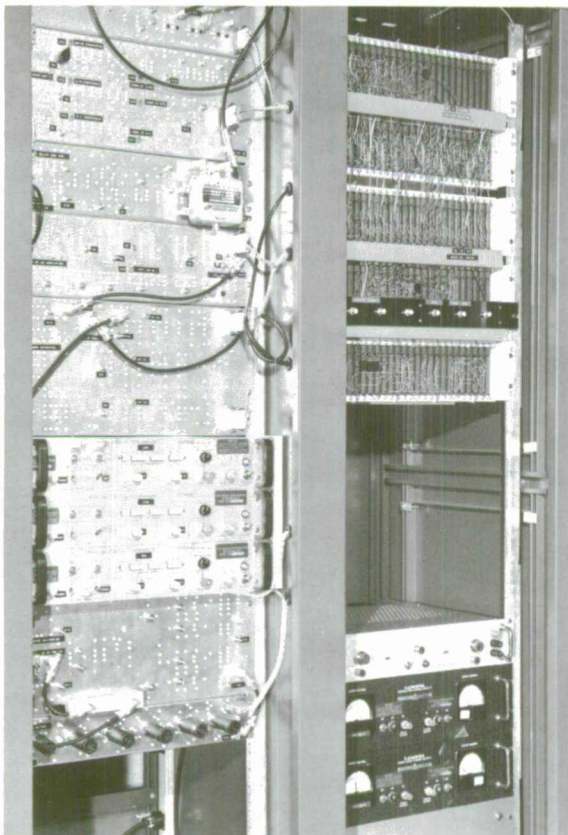

The 1000:1 Linear-FM Pulse Compression System, above provides both the coding of the radar transmitter pulse and the signal processing of the received target data. The processing circuits below digitalize the pulse time and phase for external computer computations. This system functions as an adapter that permits a one-millisecond pulse radar system to be used to produce the range resolution of a one-microsecond radar pulse and thereby improves the range resolution of the radar system by a factor of 1000.

The 10,000:1 pulse-compression system is based on a new design principle which results in a device composed entirely of tapped quartz delay lines, bandpass phase shifters, bandpass filters and resistive weighting networks. Since the performance will depend heavily upon the stability and accuracy of high-quality delay lines, the attainment of very low sidelobes at the output of the matched filter is feasible despite the extremely large pulse-compression ratio.

In a recently completed computer simulation of the 10,000:1 system, the sensitivity to component tolerances was explored fully. The simulation was so detailed that virtually no aspect of the design is subject to doubt. When completed, the pulse-compression filter can be modified easily to synthesize a wide variety of complex responses; thus, it has utility beyond that offered by direct radar applications. The tolerance studies indicate that the technique can readily be extended to larger time-bandwidth products.

The Coherent, Linear-Frequency Modulator

The coherent, linear-frequency modulator is an experimental, active, coded-pulse generator of significant simplicity currently being developed at MITRE. Since the prototype model is capable of producing phase-locked, linear-FM pulses of one millisecond time duration and one megacycle frequency excursion, it can be used as an optional method of generating the transmitted, coded waveform of the MITRE 1000:1 pulse-compression system. The passive dispersive filter of the pulse-compression system could then be relieved of the necessity for generating this waveform and more time would be free for the processing of the received signals. This would permit the processing to be continued through the next main-bang time which may prove valuable in multiple-site operation.

Alternatively, this device can be used to generate linear-FM, pulse-radar transmissions in conjunction with a radar receiver which mixes the received signal with another such frequency ramp, generated at the proper time. The result of this mixing will be an uncoded pulse of unknown fre-

quency which can be processed by the binary-delay-and-heterodyne filter to produce accurate range measurements.

The device can also be used in a receiver to convert received signals consisting of uncoded radar pulses into coded pulses that can be processed by the dispersive filter of a pulse-compression system for which the time of the output pulse would indicate the target frequency.

The basis of the technique is the use of a variable frequency oscillator, swept on command between prescribed limits in frequency at a prescribed rate. The accuracy of the oscillator output is maintained by injecting error-correcting voltages of fixed, equal intervals of time. Separate correction can be made for phase ϕ , $d\phi/dt$, and $d^2\phi/dt^2$. Errors in the output are sensed by a sampling technique which avoids the use of circuits of wide bandwidths.

The coherent, linear-frequency modulator should be adaptable to a pulse-compression system in which the frequency rate of coded pulses are readily changeable over a wide range. In fact, the slope could probably be altered from pulse-to-pulse if needed, with no sharp distinction between coded and uncoded pulses, the latter appearing simply as the special case where the slope is zero.

AUXILIARY DEVELOPMENTS AND TECHNIQUES

A Phase-Stability Measuring System

In connection with the MITRE L-band interferometer radar program, it has become necessary to make numerous measurements of the phase stability of such components as frequency standards, frequency multipliers, frequency synthesizers, exciter, transmitter, microwave relay links, and the signal data processors. An accuracy of the order of one degree at the L-band frequencies of 1250 to 1350 megacycles was required and a convenient and readily-interpreted display was essential. A measuring system was designed and constructed to fulfill this need. The required accuracy was achieved by multiplication of the phase variations in a frequency multiplier followed by frequency translation of the multiplied

frequency to the original frequency. The iteration of this process produces an output whose frequency is the same as the input frequency but with phase variations multiplied by a known factor to magnitudes which can be accurately measured. A pair of quadrature phase detectors are employed in order to obtain the sine and cosine of the phase difference. These outputs are used to provide an oscilloscope polar display in which the orientation of a radial strobe line represents the relative phase between the two input signals being compared.

A Signal Cross-Correlator

The degree of correlation of radar target returns is an important consideration in radar interferometry. For such measurements, an analog device which approximates the function of performing the mathematical operation of cross-correlation between signals received at any two of the MITRE interferometer sites has been developed. At signal-to-noise ratios greater than unity, the cross-correlation operation approaches the ideal performance of matched filtering, and its practical implementation is virtually independent of the particular signal waveform employed. Thus, the technique is quite flexible, and can be used for both short- and long-pulse transmissions. A selection of a variety of IF and post-detection bandwidths has been provided to accommodate various pulsewidths and target characteristics. The phase measurement and display are similar to that of the phase-stability measuring system previously described.

Digital Computer Programs for Filter Synthesis

Traditional filter-design techniques either fail entirely or become excessively cumbersome both in the broadband case, where contributions of negative-frequency poles and zeroes are significant, and in cases which require nonstandard amplitude and phase characteristics. It is often necessary to abandon any pretense of analytical treatment in such instances and resort to crude analog devices, such as the electrolytic tank or trial and error approximations aided by a com-

puter. Even though suitable pole-zero configurations can usually be found, there is no guarantee that a convenient physical realization exists, and the process gives no indication of the efficiency of the resultant network.

An approximation technique which is rather primitive in concept, but which nevertheless may prove to be an extremely powerful and general approach, has been coded for the 7090 computer. The desired amplitude and phase characteristics are entered as input data together with an integer N specifying the number of zeroes or poles desired in the final filter. The program then simply tries random arrangements of N singularities, computes the characteristics of each particular arrangement and compares them with the required behavior. After a given number of filters is generated and tested in this manner, the singularity configuration which best meets the original requirements is printed as output data. The demonstrated success of the technique depends entirely on the extreme high speed of the modern digital computer, for it is apparent that a very large number of random arrangements must be investigated to get reasonably good approximations. The present program can process about 6000 singularities per minute of computer operating time.

The program chooses each one of the N singularities by selecting three random numbers. The first determines the center frequency of the singularity; the second specifies the Q of the singularity; and the third is used to decide whether the singularity should be a zero or a pole. The phase characteristic of this N -section filter is calculated, and its mean-square deviation from linearity is computed. If the error is less than a preset value, the computer calculates the normalized amplitude response, and the peak difference between this response and the desired input response is compared to a second error limit. If the computed random filter satisfies both tests, all pertinent data for the filter are stored for later output, and the computer returns to the beginning of the program. When either test fails, the program destroys the calculated quantities and

recycles. After three acceptable filters are stored, the program reduces the error limits on both the amplitude and phase, and attempts to find configurations meeting these stricter tolerances.

MICROWAVE DEVICES

The Computer Design of Critically-Coupled Bandpass Filter at Microwave Frequencies

In the past, two basic approaches have been taken in the design of microwave filters. In the older approach, that of quarter-wave-coupled structures, the cavities and the connecting lengths of line are individually tuned by screws. One aligns each cavity independently, adds it to the filter, and then aligns the entire filter in a building-block process. The usefulness of this design is limited by a basic inability to obtain wide bandwidths and by high insertion losses caused by the many tuning adjustments. The second approach, that of direct-coupled resonators, eliminates the wide bandwidth limitation and the insertion losses of the first approach. However, this approach is normally incapable of producing narrow bandwidths because of the characteristics for the susceptible coupling posts which are usually assumed.

The analysis performed at MITRE is based on the direct-coupled resonator but takes into account the four-terminal characteristics of waveguide structures. The resulting design is thus applicable to both broad- and narrow-band filters. A computer program was written which yields the design requirements to fabricate a critically-coupled bandpass microwave filter. The filter incorporates centered inductive posts properly positioned along the broadwall of rectangular waveguide. The result of the program yields very good, maximally flat passband responses for bandwidths in excess of one percent. Filters fabricated with this design exhibit no spurious passbands within the permissible waveguide dominant-mode passband.

The program has been used to provide the design of bandpass filters having center frequencies ranging from 1000 to 90,000 megacycles

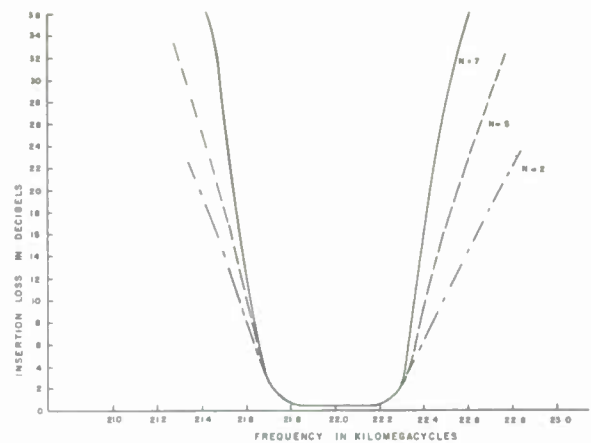

Shown here are three K-band filter designs generated by a digital computer program. The three results correspond to different design parameters and filter complexities requiring respectively three, five, and seven sections.

and has produced excellent results. The program has virtually eliminated the need for engineering calculations and design experimentation for this class of filter.

Low-Noise Amplifier Program

The low-noise amplifier program at MITRE was initiated for the purpose of investigating analytically and experimentally those low-noise techniques which possessed the potential of improving the noise performance of radar systems. The two most important results of this program have been the development of a low-noise, L-band, parametric amplifier which can be cooled to cryogenic temperatures and the development of a low-noise, L-band, tunnel-diode amplifier.

The parametric amplifier developed at MITRE has its signal coupled into the varactor diode at a voltage null of the idler circuit. This eliminates the requirements for an idler rejection filter in the signal arm and avoids the signal loss associated with these filters. Also, this parametric amplifier can be operated either at cryogenic temperatures or uncooled without the performance departing significantly from the theoretical design

figures. In addition, the amplifier can be tuned and tested from a remote location such that antenna mounting of the unit is practical.

A simple, low-cost, closed-cycle cryogenic refrigerator was developed to cool the amplifier. These refrigerators have proved superior in reliability and performance to any known commercial unit available today, and are presently capable of operating at 70° Kelvin with a heat capacity of 20 watts and an expected life of 1000 hours.

The parametric amplifier has a frequency range of 1250 to 1350 megacycles, an instantaneous 3-db bandwidth of 12 to 20 megacycles, and a gain of 15 to 18 db. The uncooled noise tempera-

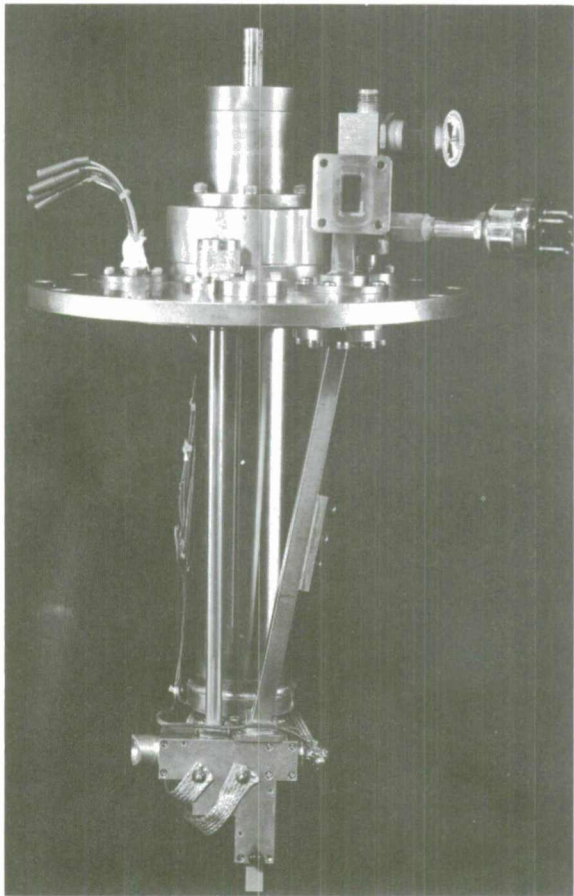

This L-band parametric amplifier used on the interferometer system provides an improved noise temperature for the interferometer receivers.

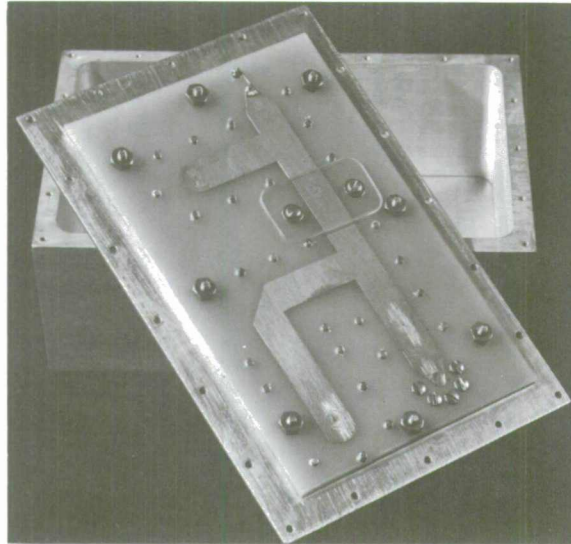

Pictured here is the low noise L-band tunnel diode amplifier which is used as a post amplifier for the L-band parametric amplifier in the MITRE interferometer system.

ture is 120° Kelvin and the cooled noise temperature is 75° Kelvin.

The L-band, tunnel-diode amplifier developed at MITRE is an amplifier of moderate noise temperature yet physically small and simple. The amplifier has been made to be absolutely stable in gain by means of a quarter-wave shunt stub which presents a real impedance to the negative resistance of the tunnel diode at all frequencies except those in the amplifier passband. It can be operated remotely such as is required for antenna mounting.

The tunnel-diode amplifier has a frequency range of 1100 to 1400 megacycles, an instantaneous 3-db bandwidth of 150 megacycles, and a gain of 18 to 20 db. The noise figure of the amplifier including its ferrite circulator is 4.8 db.

The noise temperature of radar systems is primarily dependent upon the noise temperature of the first amplifier in the system. However, if the gain of the first amplifier in the system is made low because of gain and phase stability requirements, the noise temperature of the second stage will contribute significantly to the overall

system noise-figure. A solution to this problem is to require the second amplifier to have a relatively low noise-figure.

The MITRE L-band parametric amplifier and tunnel-diode amplifier can be used in this manner, using the tunnel-diode amplifier as the second stage of amplification. Currently, these amplifier pairs including the closed-cycle, cryogenic refrigerators are being incorporated into the MITRE interferometer system at the Bedford and Boston Hill sites. Two complete pairs are being installed on the antennas at each of these sites with remote tuning and monitoring facilities provided in the building interiors.

The Design of Antenna Feed Horns

The characteristics of the antenna radiation pattern chosen for a particular sensor application are determined for the most part by the system requirements. For parabolic reflectors, the design of the radiation pattern of the feed horn determines many of these characteristics. At MITRE, considerable effort has been devoted to the design of antenna patterns and associated feed horn for radar applications. One example is a focal-plane feed horn having equal beamwidths in all radiation planes and which responds equally to all planes of polarization. In addition, this feed horn tapers the illumination at the edge of the parabolic reflector to a level 20-db below that at the center. This provides an attenuation of the radiation beyond the reflector edge, resulting in a reduction of ground noise which would otherwise contribute to the antenna noise temperature. This improved noise performance is obtained at the cost of a small increase in the antenna beamwidth and a small decrease in antenna gain.

Another MITRE development utilizes the theory of microwave lenses to correct the phase distortion in the feed horn of the L-Band interferometer antenna at Boston Hill. The hyperbolic subreflector which is used in the Cassegrainian feed system of this antenna required a horn aperture of 3.5 wavelengths. When the

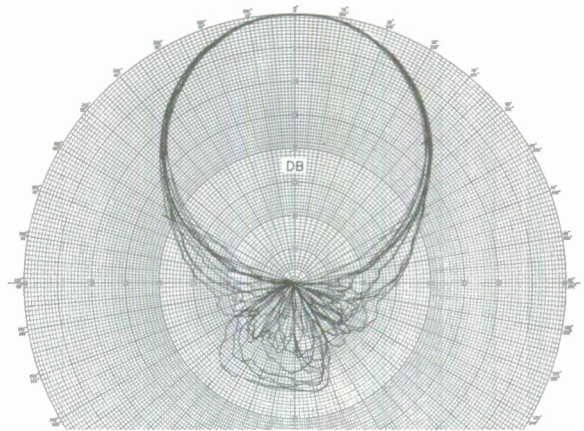

Shown here are the radiation patterns of the equal beamwidth feed horn developed at MITRE. The patterns have been taken in a number of planes and have been superimposed for comparison. This design provides an equal response for all planes of polarization and simultaneously reduces the contribution of ground noise to the antenna temperature of a parabolic antenna.

minimum horn flare-angle was determined, based upon the maximum length compatible with other structures on the antenna, it was seen that a phase error of 110 degrees occurred across the horn mouth. A phase error of this type produces a substantial broadening of the antenna pattern in the E plane of the horn beyond the 3-db beamwidth such that the nulls in the pattern are destroyed. In order for the horn to produce the desired nulls, it was required that the phase error be corrected. Metal plates and solid dielectrics are available for this purpose. To avoid the mass and the fabrication difficulties of solid dielectric lenses, the choice of a metal plate, or waveguide lens, was made. This type of lens, which is employed in the aperture of the feed horn, has an index of refraction less than unity. The lens advances the phase of the propagated energy from zero degrees at the horn center to 110 degrees at the horn edge. The correction was made in both planes in order to accommodate circular polarization. The completed design took the form of an array of square waveguides having a shorter length in the center than at the edges.

Theoretical and Experimental Investigations

A number of theoretical and experimental investigations have been made of the application of varactor diodes to microwave techniques. A class of varactor-tuned filters has been analyzed using the varactor diode as a voltage-variable, reflection model. Implementations were studied in two basic configurations. The first requires a 3-port circulator and one varactor. The second utilizes a hybrid junction, but must incorporate two varactors matched to each other. For both configurations the Q -factors were found to remain substantially constant over the tuning range. The study provides a design approach applicable to ferrite-tuned devices as well as varactor diodes.

In the area of techniques, a study was made of phase modulation of microwave carriers by varactor-diode techniques. The study investigated the modulation indices achievable under low, RF power-level conditions and determined the linearity of phase excursion versus applied bias in order to establish acceptable levels of cross-modulation. Test results showed excellent agreement between actual data and theoretical prediction of the phase of the reflected wave versus bias voltage.

A study of varactor-diode harmonic multipliers has resulted in designs which have extended this technique into the millimeter band. Included in this work was the development of two varactor doublers which are capable of producing output signals at 30,000 megacycles and 90,000 megacycles. These two developments have been incorporated into the MITRE Line Integral Refractometer System where they are used as transmitters and receiver local oscillators.

An example of the analytical work being done on antennas is a study that was made to determine the antenna noise temperature due to radiation sources, as well as antenna loss, and then to combine the antenna noise temperature and the antenna gain with the receiver temperature in order to optimize the overall system performance. The results were used to compare the noise characteristics of a parabolic antenna

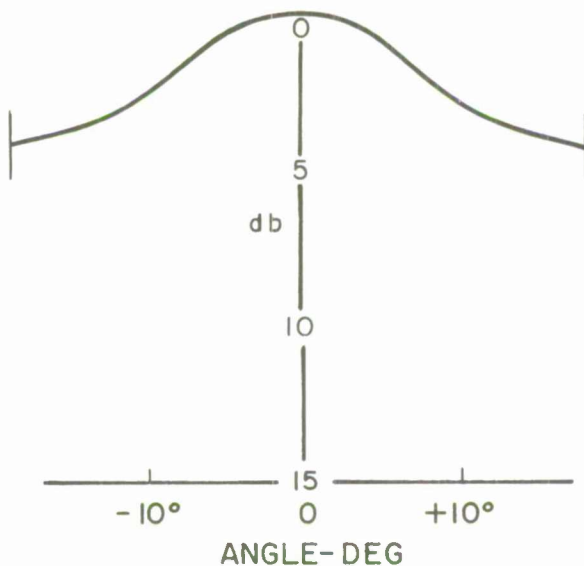
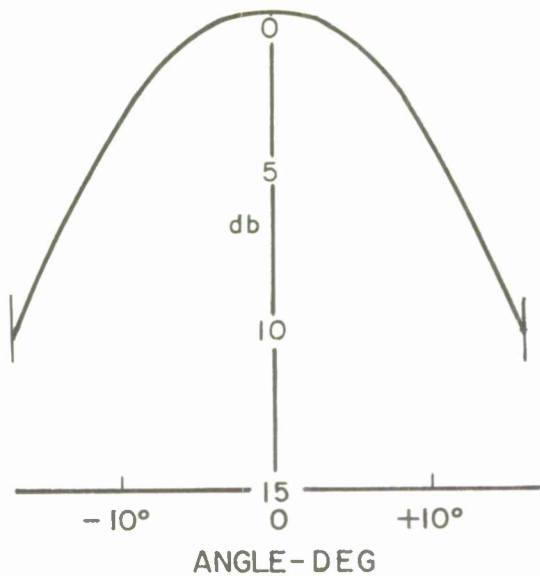

Shown above is the E-Plane pattern of an uncorrected feed horn. Below is the E-plane pattern of the same feed horn after phase correction with a metal lens. This horn is in use at the Boston Hill radar site.

with a low-noise horn, a high-gain horn, and a Cassegrainian feed. In this example, although the Cassegrainian antenna has less feed-line loss, its efficiency was less than the other two designs. The choice between the high-gain and low-noise feed designs was shown to depend upon the noise temperature of the receiver, the orientation of likely targets, and whether the same antenna is to be used as a transmitting antenna.

SENSORS FOR NUCLEAR DETECTION

In a strategic war environment, the characteristics of an enemy attack must be known to the national commander to allow him to respond in a meaningful and timely manner. Determination of the characteristics of an enemy attack is termed attack assessment. One of the primary techniques for satisfying the attack assessment function is to determine the location, yield, and height-of-burst of nuclear detonations. In support of projects related to nuclear detection and attack assessment, MITRE has found it both necessary and desirable to become involved in the specific technology problems. Two areas where significant contributions have been made by MITRE are in the detection of the electromagnetic pulse and in the detection of the thermal or optical energy emanating from a nuclear detonation.

ELECTROMAGNETIC DETECTION OF NUCLEAR DETONATIONS

One of the nuclear detection systems envisioned is an area coverage Long Baseline/Time-of-Arrival (LBL/TOA) System. To assess the feasibility of implementing such a system, an effort was undertaken to determine the technical problems involved and the capabilities possible with such a system. To study was ideal from the standpoint of system design because direct experimental evaluation of pertinent design concepts was possible.

From November 1963 to July 1964, four test vans were operated in the Eastern United States as an experimental segment of an LBL/TOA

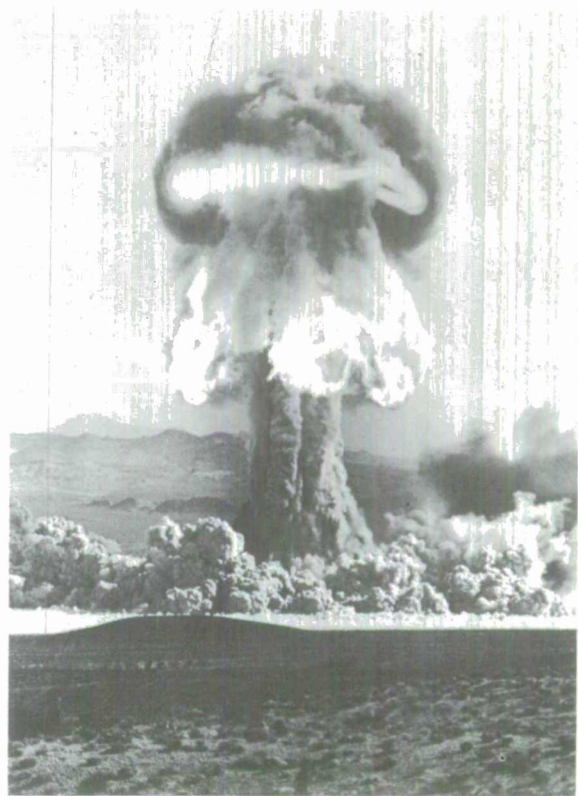

Contributions have been made by MITRE in detecting electromagnetic pulses and in detecting the thermal and optical energy emanating from a nuclear detonation.

system. Emphasis was placed on that portion of energy associated with nuclear detonations falling within the radio frequency band, particularly the low radio frequencies (VLF); that is, detection based on the so-called weapon signature or electromagnetic (EM) pulse. Specifically, two broad problems were addressed. First was the determination of the geographical accuracy with which a nuclear detonation could be located. Second was the degree to which the EM pulses of nuclear detonations could be distinguished from the EM pulses of lightning discharges (sferics).

The LBL/TOA system derives its name from the technique of determining source locations of detected EM pulses by noting the time of arrival

of the signal at three or more widely separated sites. This system requires (1) a stable, time-of-day clock, (2) synchronization of widely separated clocks and (3) exact determination of the time of arrival of an arbitrary EM pulse.

The clocks used in the feasibility study were composed of ultra-stable crystal oscillators whose outputs were counted in electronic counters. Local time was quantized to one-tenth of a microsecond. The clocks used in the feasibility study had stability of one part in 10^{10} and were synchronized to the East Coast LORAN-C chain. This was accomplished by noting the time at which the same LORAN-C pulse arrives at each of the sites. Thus, if the distances from the sites to the LORAN-C transmitter and the propagation velocity of the LORAN-C signal were known, the clocks could be synchronized.

The difficulty in determining the time of arrival of an arbitrary EM pulse at widely separated sites is a function of the earth's atmosphere and ground conductivity. As the pulse propagates, attenuation and dispersion effects will change its appearance. A simple threshold scheme for fixing the time of arrival can thus be expected to give large errors because the pulse may be radically different at different sites.

An experimental determination of the locating accuracy of the LBL/TOA system was obtained in two ways. First, an artificial sferics generator was used as a known source of EM pulses. The source location as determined by the system when compared against the actual source location gave a positive indication of the system accuracy. An analysis of 687 artificial discharges showed that 99% were located within 1.8 kilometers of the generating site. Second, redundant natural sferics data served to imply something about the system accuracy. It will be recalled that three LBL/TOA sites serve to give a single source location. If a fourth site is added to the other three, then three independent source locations can be determined. If there were no errors, the three source locations should be identical. However, small random errors will spread the three source locations. Thus, the spread in the source

locations for four sites should bear a probabilistic relationship to the errors of three-site source locations. An extensive analysis of the redundant source patterns inferred that the accuracy in locating natural sferics was no worse than the accuracy in locating artificial sferics.

The characteristic distributions for sferics were based on a population of 800,000 sferics recorded over a period of nine months. Each recorded sferics had 22 characteristics measured. Ten of these were real-time measurements; e.g., rise time, peak amplitude. The remainder were spectral measurements; e.g., the ratio of waveform energy at 60-kc to 10-kc. The characteristics distributions for weapons were restricted because a very limited catalog of weapon signatures exist. This restriction places an upper limit on the probability of detection which sensibly can be used to describe a detection system.

The data gathered from the field experiment serve to identify five effective discriminants or characteristics on which weapon pulses and sferics could be distinguished. In addition, a statistical model of the sferics environment was determined. Using the model sferics environment as an input to a hypothetical system, using the most effect discriminants available, gave an estimate of the false-alarm rate which was dependent on the sensor separation or maximum detection distance. The results for a 400-kilometer square grid of sensors indicated a false-alarm rate of 0.5 to 12 per day. The spread of false-alarm rates is due to average sferics activity based on season. For example, the lower figure is for the winter months and the higher figure for the spring-summer months.

OPTICAL DETECTION OF NUCLEAR DETONATIONS

The major portion of the optical detection study effort has been concerned with establishing the feasibility, preliminary design, and the predicted performance capabilities of a surveillance system which would detect nuclear detonations at long ranges (300 to 500 kilometers) within the United States by passive optical equipment. The

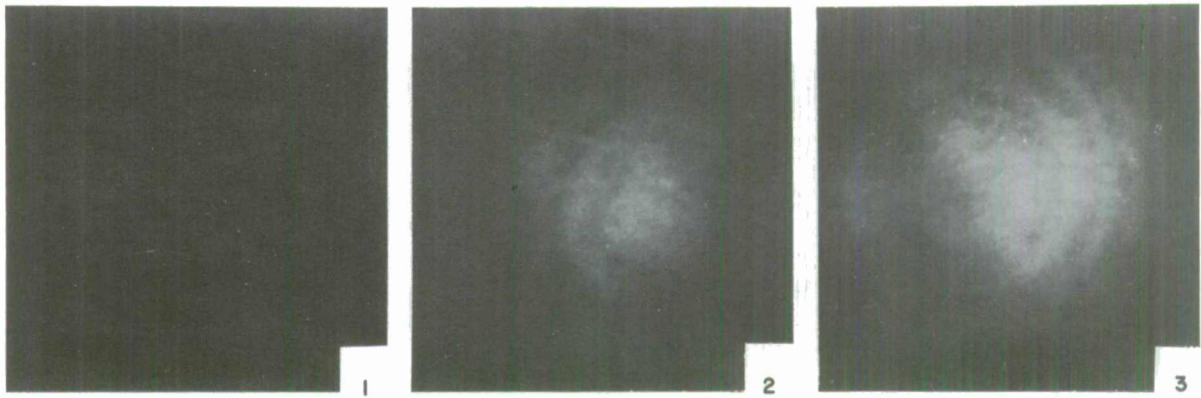

- (1) *Laser light transmitted through an unpumped ruby lens is extinguished on the recording film by a bank of neutral density filters.*
- (2) *With the ruby lens pumped to 1.5 KV light can penetrate the filter bank.*
- (3) *The ruby lens is pumped to 2 KV.*

design characteristics of the optical sensor are based on knowledge of the thermal radiation characteristics of nuclear detonations, the propagation characteristics of these signals over long ranges and the information content of the signal and noise radiation received by the optical sensor.

The optical sensor is required to detect the characteristic thermal radiation from the fireball while discriminating against unwanted sources of background radiation noise. The average spectral background-radiance characteristics have been analyzed from reported experimental programs. The intensity levels have been examined as a function of such factors as the sun elevation angle, the segment of the sky being viewed relative to the sun portion, and the concentration of the various atmospheric constituents.

One of the major problem areas confronting the detection study has been to quantitatively determine the effect of the various meteorological parameters on the characteristics of the radiation at the aperture of the optical system. The problem has further been complicated since the coverage requirements of the search field necessitated

the detection of nuclear detonations over the horizon from the optical sensor field-of-view. A literature review has shown that very little effort has been expended on the transmission problem of optical signals over the horizon. In an attempt to acquire quantitative data, atmospheric models based upon reported experimental data, have been generated and the transmission of optical radiation over the horizon through these model atmospheres have been computed from single scattering theory. Although the technique is limited and allows at best estimates of the transmission of optical radiation through long atmosphere path-lengths, it allows the best available approach to the problem until multiple scattering computations are feasible and/or controlled, long-range test data becomes available under varying atmospheric conditions.

The results of the optical detection study indicate that significant capability exists for detecting the optical signal of nuclear detonations over the horizon. The results to date, however, have been based entirely on theoretical studies. To demonstrate the results experimentally, a project has

been initiated to build an optical sensor and make actual measurements of the environment.

OPTICAL TECHNOLOGY

COHERENT, OPTICAL LENS-AMPLIFIER

The development of the laser as a source of coherent light has stimulated interest in its application within optical sensor systems. In some of these systems, an amplifier is an essential element. The use of active focusing elements in both the source and the amplifier suggests advantages for coherent optical target-acquisition and ranging devices. For example, a target can be illuminated through a system of coherent lens-amplifiers and be observed in a parallax-free manner through the same system.

MITRE has recently operated a coherent lens-amplifier with spherically convex end-surfaces. Such a device does not have to be optically decoupled from a laser with plane parallel ends, thus several of these lens-amplifiers can be operated in succession without decouplers. Furthermore, the volume of active material that is swept out by the incoming laser beam can be varied in such lens-amplifiers. This permits higher amplification for the same volume than is possible for amplifiers using plane ends.

A laser and successive lens-amplifier stages can also perform the functions of an optical instrument. For example, projection optics and telescopic photographic optics were demonstrated as follows: a slide was projected onto a screen using coherent light from a laser; also a laser illuminated target was photographed through a telescopic lens. In each case a coherent lens-amplifier was used as one of the lens components.

The possibility of using a laser material as a lens-amplifier is suggested by the physical properties of the material. The absorption coefficient and refractive index of a laser material close to an absorption line depend on the difference of the occupation numbers of the two energy levels between which the absorbing transition occurs. The ratio of transmitted to incident light intensity decays exponentially with the occupation number

difference, the length of the material, and the absorption cross-section for the transition. When the laser material is pumped, a population inversion occurs, reversing the sign of the difference of the occupation numbers. The refractive dispersion curve changes sign as the population inversion takes place, and the refractive index becomes a function of the pump power. The exponential decay of relative light intensity becomes an exponential increase, and the material amplifies, rather than absorbs, the incident light.

A chromium-doped mellor ruby was designed as a thick lens of length 6.35 cm and diameter 9.5 mm. The end-faces were spherically convex and coated with an anti-reflection layer acting selectively for 6943 angstroms, the ruby laser wavelength. The lens was pumped by means of two FX-51 flashtubes mounted in an aircooled cylindrical reflector housing. A second chromium-doped Mellor ruby having flat silvered ends functioned as the light source. This ruby was housed in a separate, cylindrical reflector housing and pumped by an FX-42 flashtube. Both the laser and the thick-lens ruby amplifier could be pulsed simultaneously.

Experimentally, it was demonstrated that the thick ruby lens, when pumped, amplifies ruby laser light and that the focal length changes with pump power, unaccompanied by any noticeable change in the image transmission quality of the lens. The ruby lens was illuminated with collimated, ruby-laser light from the source, and used as one element of a projector illuminating a camera. Sufficient neutral density filters were placed in front of the camera to render the laser spot just extinguished on the recording film when the ruby lens was not pumped. When the ruby lens was pumped, the image was intensified as predicted, providing enough amplification so that the transmitted, laser-light intensity exceeded the film inertia and a recorded image was observed. It was verified that fluorescence from the pumped ruby lens did not penetrate the filter bank. Pumping the lens at two kilovolts produced an intensity gain of approximately 4.5 db.

With the filter bank removed, and a wire grid interposed between the laser and imaged on the camera, a sharp reduced image could be obtained with the ruby lens unpumped. Pumping the lens produced a variation in focus, dependent on the pump power. Additionally, the amplifier lens was used in conjunction with a converging lens to form projection optics, which was used to project a slide containing a group of letters onto a screen. When the amplifier lens was unpumped, the image was very dim and lacking in contrast; with the lens pumped, a sharp image with improved brightness and contrast was obtained.

DOCUMENTATION

Advanced Development Subdepartment, *Subdepartment Quarterly Progress Report*, ESD-TDR-63-298, August 1963 (Unclassified).

Advanced Techniques Subdepartment, *Subdepartment Quarterly Progress Report*, ESD-TDR-63-296, August 1963 (Unclassified).

Advanced Techniques Subdepartment, *Subdepartment Quarterly Progress Report*, ESD-TDR-63-441, September 1963 (Unclassified).

Altman, J. L. *Impedance Transformation Properties of Waveguide Tee- and Y-Junctions*, ESD-TDR-63-267, April 1963 (Unclassified).

Altman, J. L., Bates, R. H. T. 2nd, Fowle, E. N. *Introductory Notes Relating to Electromagnetic Inverse Scattering*, SR-121, The MITRE Corp., September 1964 (Unclassified).

Bark, A. and Lanczi, E. R. *Optical Amplification in Thick Lenses—Part I and II*, TM-3997, The MITRE Corp., April 1964 (Unclassified).

Bates, R. H. T. *The Effect of Polarization Rotation in the Ionosphere Horizon Search Radars*, ESD-TDR-63-250, February 1963 (Unclassified).

Bates, R. H. T. *Graphical Presentation of the Statistics of Fluctuating Target Detection by Pulse Radar*, SR-120, in press (Unclassified).

Bates, R. H. T. "Mode Theory Approach to Arrays," *Trans. IEEE (PGAP)*, in press (Unclassified).

Bates, R. H. T. *Several Methods of Source Synthesis for Antennas*, ESD-TDR-63-451, July 1963 (Unclassified).

Bequaert, F. C. *Some Limiting Factors in Radar Measurement Accuracy*, ESD-TDR-63-255, March 1962 (Unclassified).

Bequaert, F. C. and Chin, T. A. *Deceleration and Its Higher Time Derivatives for Objects During Atmospheric Entry*, ESD-TDR-63-489, March 1962 (Unclassified).

Bequaert, F. C. and Manasse, R. *Determination of Signal Frequency, Phase and Amplitude from the Outputs of the Sequential Doppler Processor Fine Doppler Integrators*, ESD-TDR-63-203, 1963 (Unclassified).

Bickel, S. H. *On Antenna Noise Temperature*, TM-04031, The MITRE Corp., June 1964 (Unclassified).

Cozzens, D. E. "A Nomograph for Matching Microwave Transmission Lines with Dielectric," *Microwave Journal*, 7, 11 (1964) (Unclassified).

DiDio, V. A. *A Computer Program for Determining the Radar Co-ordinates of a Ballistic Missile*, ESD-TDR-63-163, September 1962 (Unclassified).

DiDio, V. A. *Satellite Interception Capability of BMEWS*, ESD-TDR-63-452, May 1963 (Unclassified).

- Engelman, C. "Infix-Prefix and Prefix-Infix Translation Programs," *J. Assoc. Computing Machinery* (Unclassified).
- Engelman, C. *Mismatched Filters*, TM-3073, The MITRE Corp., May 1961 (Unclassified).
- Engelman, C. *Mismatched Filters II*, TM-3128, The MITRE Corp., August 1961 (Unclassified).
- Fowle, E. N. "The Design of FM Pulse Compression Signals" *Information Theory*, 1T-10, 1, January 1964; see also ESD-TDR-63-473 (Unclassified).
- Fowle, E. N. *The Independent Specification of the Modulus of a Function and the Modulus of its Fourier Transform*, ESD-TDR-62-312, August 1962 (Unclassified).
- Fowle, E. N., Carey, D. R., Vander Schuur, R. E. and Yost, R. C. "A Pulse Compression System Employing a Linear FM Gaussian Signal," *Proc. IEEE*, 51, 2, (1963) (Unclassified).
- Gallagher, R. D. "A Microwave Tunnel Diode Amplifier," *Microwave Journal*, 8, 2 (1965); See also ESD-TDR-64-100 (Unclassified).
- Haggarty, R. D. *Tapped Delay Line Synthesis of Large Time-Bandwidth Signals*, ESD-TDR-63-180, June 1963 (Unclassified).
- Houlding, N. "Oscillator Noise," *Proc. IEEE*, in press (Unclassified).
- Jacobus, R. W. "A Linear-FM 1000:1 Pulse Compression System," IEEE-Military Electronics Group; see also ESD-TDR-63-237 (Unclassified).
- Jacobus, R. W. *Uncertainties in Satellite Position Due to Solar Radiation Pressure Effects*, ESD-TDR-64-147, November 1964 (Unclassified).
- Kellogg, W. C. *Results of Overflight Study*, ESD-TDR-63-162, September 1962 (Unclassified).
- Kibbler, G. O. T. H. *CAVORT—A Radial Acceleration and Velocity Filter*, TM-3116, The MITRE Corp., July 1961 (Unclassified).
- Lanczi, E. R. "Amplification in a Thick Ruby Lens" *Applied Optics*, 4, 2 (1965) (Unclassified).
- Manasse, R. "Maximum Angular Accuracy of Tracking a Radio Star by Lobe Comparison," *IRE Trans. Antennas and Propagation*, AP-8, 1, January 1960 (Unclassified).
- Manasse, R. *Parameter Estimation Theory and Some Applications of the Theory to Radar Measurements*, ESD-TDR-62-50, April 1960 (Unclassified).
- Manasse, R. *Position and Velocity Errors Resulting from Imperfect Estimation of Nearly Circular Satellite Orbits*, ESD-TDR-64-77, January 1964 (Unclassified).
- Manasse, R. *Simplified Pointing Equations for Slaving an Antenna to the Radar Coordinates of a Master Site (and Specialization to Earth Rotation Corrections)*, ESD-TDR-63-492, November 1962 (Unclassified).
- Manasse, R. *Summary of Maximum Theoretical Accuracy of Radar Measurements*, ESD-TDR-62-151 (Unclassified).
- Manasse, R. *Tapped Delay Line Realizations of Frequency Periodic Filters and Their Application to Linear FM Pulse Compression*, ESD-TDR-63-232, June 1963 (Unclassified).
- Microwave Techniques Subdepartment Subdepartment Quarterly Progress Report, ESD-TDR-63-297, August 1963 (Unclassified).

Murphy, A. P. and Phillips, J. H. *Electron Beam Parametric Amplifier*, ESD-TDR-63-256, March 1963 (Unclassified).

Newman, S. M. *ERBM Coverage and Threat Parameters—Summary*, ESD-TDR-64-83, November 1963 (Unclassified).

Perry, B. D. *On Bandwidth-Saving With Respect to the CMF, BDHF, and Certain Tapped Delay Line Systems*, TM-4080, The MITRE Corp., September 1964 (Unclassified).

Phillips, J. H., Gallagher, R. D. and Bridge, W. M. *The Critically Coupled Filter at Microwave Frequencies*, ESD-TDR-62-150, May 1961 (Unclassified).

Proceedings of the Second Tropospheric Refraction Effects Technical Review Meeting, Vol. I—March 1964, Vol. II—April 1964, Vol. III—May 1964, ESD-TDR-64-103 (Unclassified).

Proceedings of the Third Tropospheric Refraction Effects Meeting, Vol. I—November 1962, Vol. II—in press, ESD-TDR-64-148 (Unclassified).

Shackford, R. F. *The Use of Satellites for Calibration of BMEWS Radar*, ESD-TDR-63-454, January 1963 (Unclassified).

Sullivan, J., *Line Integral Refractometer*, SR-112, The MITRE Corp., August 1964 (Unclassified).

Ueberschaer, M. *The Effects of Mismatch and Distortion on The Output Signal of a Linear-FM Pulse Compression Filter*, TM-4043, The MITRE Corp., June 1964 (Unclassified).

Ueberschaer, M. *Interpretation and Comparison of Output Signals from Linear-FM Pulse Compression Systems*, ESD-TDR-64-129, August 1964 (Unclassified).

Ueberschaer, M. *Phase and Envelope of Linear-FM Pulse Compression Signals from High-Velocity Targets*, ESD-TDR-64-128, August 1964 (Unclassified).

Wall, R. B. *Test Plan for BMEWS Multipath Tests at Thule Air Base Greenland for 496 System Project Office*, TM-4001, The MITRE Corp., May 1964 (Unclassified).

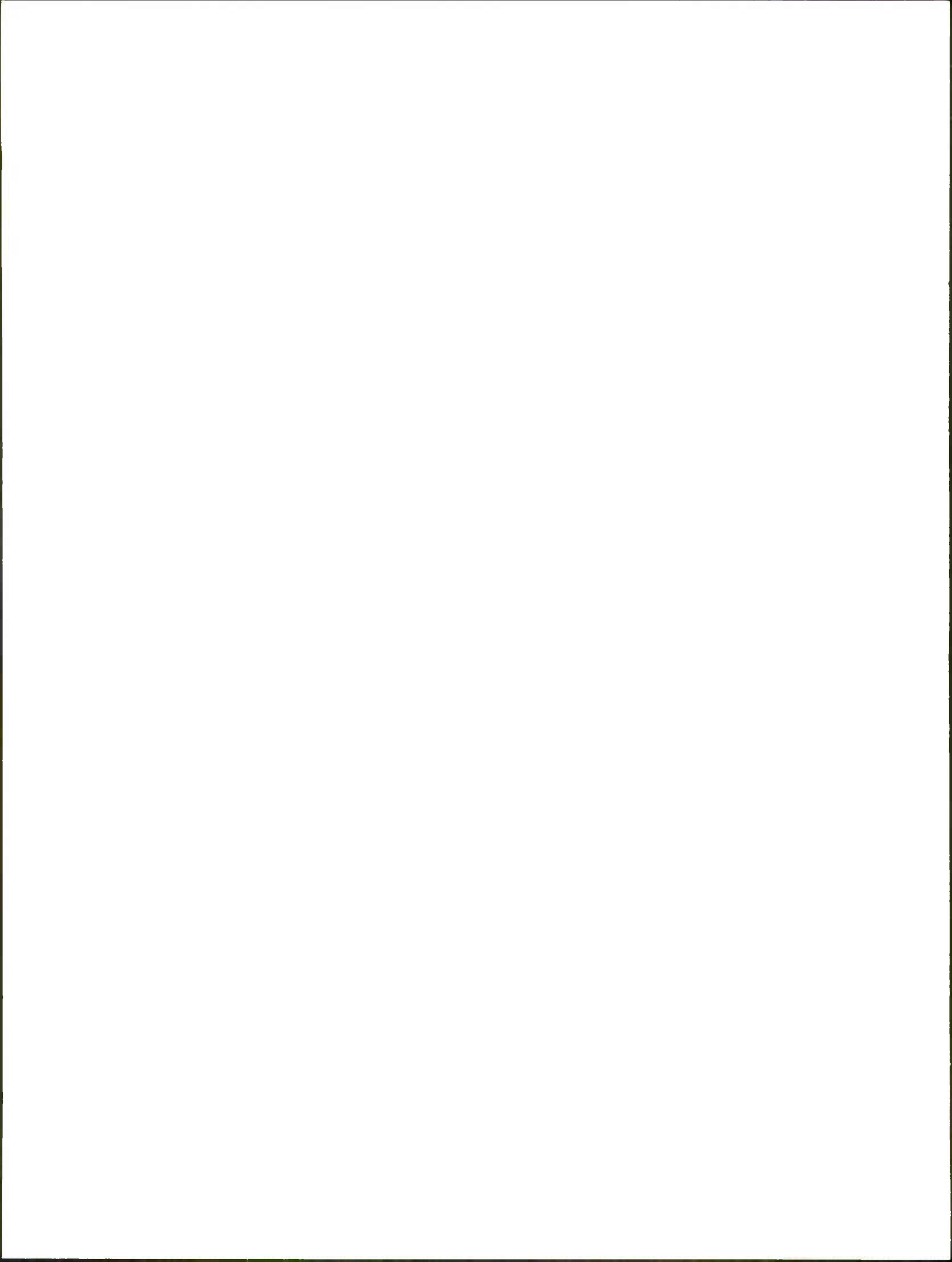

III COMMUNICATIONS SYSTEMS TECHNOLOGY

Among the advancing technologies during the past fifteen or twenty years none, perhaps, have been so greatly challenged as the methods for information exchange. Modern data processing and computing equipment has made it possible to ask for and process astronomical amounts of detailed data. Methods for transmitting such large amounts of information in a varying military environment, and with sufficient reliability, have not always kept pace with data processing techniques. MITRE has been deeply involved, since its inception, with the transmission and processing of digital data as a tool of the military command structure. A continuing series of tests, studies, and investigations have of necessity been carried out in order to identify problem areas in communications data exchange and to evaluate and compare the performance of competing equipment approaches. Through these efforts, significant contributions have been made toward solving problems of digital communications, both in the methods of implementation and in the netting philosophies to achieve reliable and survivable communications.

MITRE's efforts in communications systems technology, particularly in the areas of data transmission, modulation techniques, network survivability, and error-correction devices, is discussed below.

EXPERIMENTS AND TESTS IN DIGITAL DATA TRANSMISSION

Five examples of typical experimental programs are presented here:

A series of comparative tests of competitive digital data modulator/demodulators (modems).

A test of data transmission via switched networks, using prototype modems developed for SAGE and BUIC.

A test of digital transmission over high frequency (HF) radio circuits, to study propagation problems and compare several modems. A test of ultra high frequency (UHF) reliability in a post-attack situation.

A test of UHF ground-to-air digital communication, to explore the practical difficulties for airborne command posts that might be encountered.

COMPETITIVE DIGITAL DATA MODEMS

In April of 1961, MITRE completed its analysis of the tests of digital data modems in both laboratory and operational environments. The test results were examined in terms of application to telephone lines, radio circuits, and switched network facilities. This study, the first of its kind, has attracted immediate and widespread attention, strongly influencing the techniques of modem design and standardization throughout the industry.

DIGITAL DATA TRANSMISSION OVER SWITCHED TELEPHONE NETWORKS

As a direct offshoot of the digital data modem study, a follow-up experiment was initiated to test the performance of SAGE and BUIC data modems over the switched telephone network. With the cooperation of AT&T, cross-country circuits were provided on a dial-up basis, such that digital data could be transmitted via the telephone network over great distances and looped back to the starting point for comparison with the original message. Using this technique, MITRE not only accomplished a realistic evaluation of the modems in their normal operating environment, but also accumulated a wealth of information about the transmission characteristics of the switched network itself.

The preparation for the above studies has produced valuable by-products. For one, a better coding scheme for the BUIC modem was devised, verified and recommended. Its adoption resulted in a decreased error rate using the same transmission facilities. For another, a specialized piece of test equipment to analyze impulse noise was developed. Models of this equipment are currently in demand by military and commercial organizations.

HF RADIO DATA TRANSMISSION

For data transmission on a global basis, HF radio propagation, utilizing ionospheric reflection,

frequently offers the only expeditious and economical solution. This medium is quite often nonhomogeneous, and propagation parameters vary with time and frequency. It presents unique problems of distortion, interference, and other phenomena which corrupt communications quality. The effect of some of the anomalies encountered can be alleviated or eliminated by the application of certain radio frequency equipment design techniques, or by employing specialized signal processing in the data modem terminal equipment. To implement such improvements, the communications system engineer must be equipped with accurate knowledge of the nature and magnitude of these phenomena. A considerable effort has been aimed at identifying the problems of HF ionospheric communications and perfecting techniques which are applicable to their solution.

Although it was recognized at the outset that a complete HF improvement program would have to include work on all elements of the radio terminal installations, researchers decided to concentrate on the problems peculiar to trans-equatorial, multi-hop propagation, followed by a

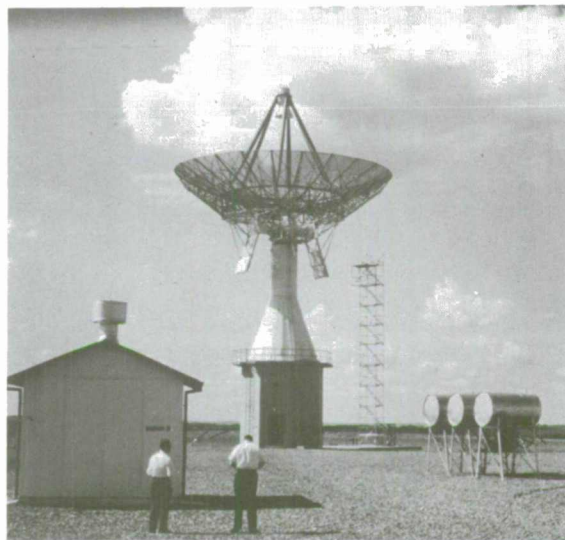

Station 13 of the Air Force Eastern Test Range near Pretoria, South Africa, is linked to Cape Kennedy by high-frequency radio circuits. The objective of the MITRE test program was to provide recommendations for improved digital data transmission over these circuits.

companion program of appropriate data modem development. Since controlled field measurements of the effects of HF propagation on digital data transmissions were meager, a field test program was initiated in 1963. By 1964, it was possible to conduct two 30-day tests (April and June/July) over a commercial HF radio circuit between Riverhead, N. Y., and Pretoria, S. Africa. The data collected on the environmental conditions of the tests formed the basis for and evaluation of recent modem developments, particularly with regard to the aberrations related to the various modulation schemes. The "cause and effect" parameters, documented as a result of this evaluation, are now under analysis.

The experimental program has proved extremely valuable in providing the needed data for a realistic approach to the problem of error-coding design for different modulation schemes. Consequently, there is in progress a continuing effort which draws upon this experimental data and involves the application of these modem-error statistics to coding and the "cause and effect" relationship in newer high-capacity modem designs.

UHF AIR/AIR TRANSMISSION

In early 1962, the Post-Attack Command and Control System requested information on the reliability and survivability of UHF communication of digital data in a network including ground stations and maneuvering aircraft. MITRE undertook an analysis, and while it was under way it was found that aircraft suitable for obtaining test data were to take part in the Fishbowl series of Operation DOMINIC in mid-1962. By slight additions and modifications to the data recording planned for these aircraft and their associated ground stations, information on the effects of nuclear detonations on UHF transmissions could be gathered, and the request satisfied.

MITRE assembled and operated equipment to record UHF signal strengths. A statistical analysis of the data showed that, for over-water paths, multipath fading was more of a problem than that posed by aircraft maneuvers. As had been predicted, high altitude nuclear detonations caused no

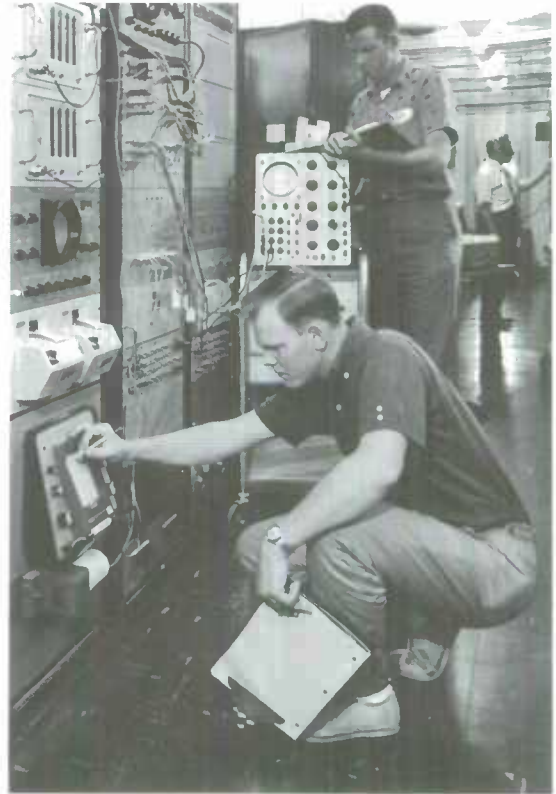

This receiving and data measuring equipment was used at Riverhead, New York, during two 30-day tests to determine the effects of high-frequency propagation on digital data transmission.

significant degradation on UHF communications paths in the vicinity of (but not through) the event.

UHF GROUND/AIR TRANSMISSION

In studying aircraft communications, MITRE has examined the transmission of digital data between ground stations and the Strategic Air Command Airborne Command Post System, which provides SAC with a survivable Command and Control capability. This system utilizes the AN/ARC-89(V) communications subsystem for ground/air communication and aircraft intercommunication. Although the initial use of the AN/ARC-89(V) system was limited to voice

and teletype communication, increasing requirements for information transfer between the aircraft and SAC ground installations led to a requirement to utilize the AN/ARC-89(V) system for data transmission. Accordingly, tests to determine the feasibility of ground/air data transmission through the system, and to identify potential problem areas, were begun.

The ground/air channels of the AN/ARC-89(V) are provided through frequency modulation of UHF radio equipment by conventional frequency division telephone multiplex equipment. It was, therefore, not surprising to find that the channel characteristics differed from those of the usual commercial telephone circuits (largely because of the noise and fading which were the result of the moving airborne environment). When the system was used to transmit data at 1200 and 2400 bits per second, intermodulation and cross-talk between active multiplex channels was far more serious than could be tolerated. The intermodulation and cross-talk were due in part to excessive channel signal levels within the AN/ARC-89(V) system, and to nonlinearity within the UHF equipment. The excessive noise level was related to the operation of aircraft auxiliary equipment and, possibly, to the aircraft engines themselves. It was concluded that the problems of high noise level, inter-modulation, and cross-talk would have to be solved if data transmission at reasonable error rates was to be realized.

The project under which this work was done was cancelled before the completion of the investigation and the correction of equipment deficiencies, and consequently the successful transmission of data at acceptable error rates was not demonstrated. Recently, interest in this data transmission problem has revived, both in conjunction with the SAC Airborne Command Post and in other systems where the AN/ARC-89(V) or similar equipment is employed, such as the "Nightwatch" aircraft of the National Military Command System. MITRE's initial equipment tests have helped significantly in isolating the problem areas in airborne command post applications, and provide a solid foundation for future efforts.

ANALYSIS OF OPTIMUM MODULATION TECHNIQUES

Unified Tracking, Telemetry and Command (TT&C) systems, such as the Air Force's Space-Ground Link Subsystem (SGLS) and NASA's Unified S-Band System (USBS), are being developed to transmit a diverse variety of information functions between a space vehicle and a ground station. The functions are frequency multiplexed on subcarriers, and the composite baseband phase modulates an RF carrier. The functions may include PAM/FM, voice, and PCM/PM with bit rates varying up to one megabit per second, as well as ranging signal.

In supporting ESD responsibilities with regard to the development of the Space Ground Link Subsystem, MITRE conducted an analysis of the proposed baseband configuration design. This analysis indicated that, in order to distribute available power optimally among the various functions which have such a wide variety of data rates, a significant percentage of available power was wasted in subcarrier intermodulation products and excess carrier power. Furthermore, this study showed that a significant increase in efficiency of power allocation and spectrum occupancy always results if a second RF carrier is used for the high data rate PCM function.

The baseband signal of a typical unified system is assembled by modulating the functions on subcarriers whose frequencies are chosen to minimize mutual interference. Adequate guard bands between subcarriers are allotted, but total spectrum occupancy is kept at a minimum. The best performance in information demodulation is attained by maximizing the power in the subcarrier components of the signal. The transfer of power from the carrier component to the sidebands is restricted, however, by the necessity to keep total spectrum occupancy at a minimum, to leave a sufficient carrier component to insure carrier-lock loop synchronization, and to operate in the linear range of the carrier phase detector. These requirements prevent wide phase deviations of the carrier and complete suppression of the carrier component. Within these restrictions, the best

system performance is achieved by maximizing the power in the first order sidebands of the signal. Choosing the modulation indexes in a suitably optimum manner will satisfy this requirement.

Given the bandwidths and the minimum acceptable signal-to-noise ratios of each function, and assuming the noise density is uniform over the spectrum, the relative fractions of power required by each function to meet some criterion may be calculated. A suitable criterion is that all functions threshold simultaneously.

The power spectrum of a carrier which is phase modulated by subcarriers may be described by a sum of products of Bessel functions with the subcarrier modulation indexes as arguments. The modulation indexes are chosen to maximize the power allocated to the information. When one of these subcarrier functions directly modulates a second carrier instead, then a ratio comparison of the power spectrum expressions for the two cases may be mathematically reduced and simplified to show the degree and conditions of improvement in power allocation efficiency that is possible. Additionally, the analysis shows that an improvement is always possible for the two-carrier case and that, in general, the improvement varies with the modulation index of the separated subcarrier function.

This study resulted in a major design improvement in the Space Ground Link Subsystem.

Use of the two-carrier configuration with the same design considerations as for the single-carrier configuration has shown a 64 percent increase in power in the high data rate PCM function, and a 50 percent reduction in power wasted in intermodulation distortion products. Additionally, the spectral occupancy for a particular case was reduced from 14 Mc for a single-carrier design to 10 Mc for the two-carrier design. Other advantages that result from the two-carrier configuration are due to the greater degree of independence of the functions from one another. In other words, if one function changes in information rate, required power allocation, or subcarrier frequency,

the effect on the other functions is less for the two-carrier system than for the one-carrier system.

FLEXIBLE ERROR-CORRECTING CODER-DECODERS

Studies of errors in tropospheric scatter and high-frequency radio teletype communications show that, although various disturbances often produce error rates in excess of acceptable standards, the information-theoretic capacity of such channels under poor conditions is around 0.9 bit per bit. It follows from C. E. Shannon's fundamental theorem of coding theory that it is possible in principle to encode (introduce redundancy into messages to be sent) and decode (compute the original message from the received redundant message) in such a way as to eliminate nearly all errors that occur in transmission and demodulation outside of long faces at an information rate near 0.9. (The information rate is the ratio of data bits to total bits, i.e., data + check, sent over the channel.)

Reduction of the underlying theoretical principles to practice by means of suitable algorithms and logical design, has been performed under MITRE's independent research program.

The preliminary logical design for a member of a family of variable-rate error-correcting and detecting devices has been carried out, along with studies of error distributions in certain real channels. Studies indicate that the devices will be the first to offer substantial fulfillment, in practical terms, of the promise of Shannon's discoveries, because they are the first with the following three properties:

They are a family of codes of increasing block length and variable redundancy of perfect efficiency; that is, each member of the family uses exactly the theoretical minimum of redundancy for correcting those errors that it can correct. They utilize a decoding algorithm efficient enough to provide multiple error correction within long blocks at high bit rates. It is only by going to long blocks (thousands, rather than hundreds of bits) that effective error correction can be obtained.

Their error-correcting capability is matched to real channels. Unlike other error correctors, which are designed for independent bit errors, or for single error burst correction, the family of error correctors use their redundancy to correct the kinds of errors that occur in real channels, namely, a combination of isolated bit and multiple burst errors.

According to estimates derived from observed error distributions, the effect of these advantages will be to improve decoded error probability by several orders of magnitude over that of other existing and proposed error correctors. At the same time, these advantages will permit a much smaller portion of the available channel bit rate to be devoted to redundant encoding. This means, typically, that, outside of long fades, the prototype now under construction should correct except for one or two seconds per day (and would detect even this shortcoming), as compared with other error correctors which fail to correct one or two seconds out of every ten seconds. In addition, the prototype would use 20 percent of the channel bit rate for redundant encoding as compared with 50 percent for other correctors. An expanded version of the error corrector would provide the same performance while using only 10 percent

redundance or at the same 20 percent redundancy would give very much smaller decoded error probability.

COMMUNICATIONS NETWORK SURVIVABILITY

MITRE is assisting the Defense Communications Agency (DCA) in assessing the impact of a nuclear attack on the communications facilities, routes, and networks of the Defense Communications System. This responsibility includes the development of a computer program which will simulate the attack, evaluate its effect on the individual facilities used in the DCS networks, and translate the effects of damage to facilities into damage to routes and/or complete networks.

This work is an outgrowth of early map exercises in which facilities were plotted and connected to indicate routes and networks. It soon became evident that, because of the numbers of facilities involved, and the desirability of varying attack parameters, map exercises involving hand calculations of facility damage and network degradation were completely impractical except for small exercises. However, this type of analysis is amenable to computer simulation, and through the development of appropriate computer programs, a computerized technique became available for evaluating the effect of a nuclear attack on communications facilities and networks in which the communications system is not necessarily the target. This technique is called "KILLCOM."

Inputs to the computer programs include a description of the facilities of the network under consideration. The facilities are specified in terms of their location and their vulnerability to nuclear effects. So that simulated attack can be directed against any desired target, programs are designed to include target locations, weapon yield, height of burst, weapon reliability, and circular probable error (CEP).

A specific program operates on the weapon parameters of reliability and CEP by means of a Monte Carlo—trial and error—technique to determine whether or not the weapon has detonated and, if so, its actual ground zero (based on the

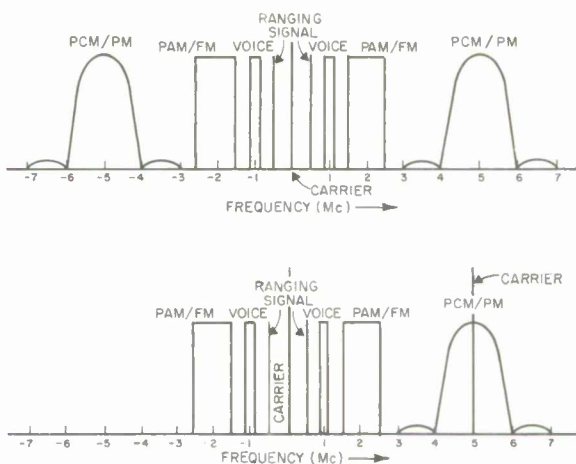

Comparison of single- and double-carrier baseband design for a unified tracking, telemetry, and command system downlink illustrates the reduction in spectrum occupancy for the two-carrier configuration.

desired ground zero and the CEP). The program also calculates radii of vulnerability (R_V) of the communications facilities in the vicinity of the target, basing the calculations on hardness of the facility (expressed in psi), the weapon yield, and the height of burst. For example, if the weapon explodes within a circle whose radius is the R_V of the facility, the facility is considered destroyed. If not, the facility is considered undamaged. Having determined which facilities were damaged, the program then relates facilities damage to network damage. By repeating the calculations of a number of times (twenty is usually adequate), the KILLCOM technique provides a means for evaluating the survivability of a system under nuclear attack conditions. By means of parametric analysis, the computer program will pinpoint weaknesses in the network and provide design information on how to improve its survivability.

In addition to network survivability, the performance of the network in terms of the grade of service under the conditions of the attack is also of interest. A computer program to analyze network performance has been developed. This program requires as an input the type of information produced by the damage-assessment model used by DCA in its survivability analysis exercises. The output of the model is not compatible, however, with the input requirements of the network performance model. To provide a means for operating the two programs in tandem, MITRE has developed the MATCHPOINT Programs, which accept facilities-damage information from the assessment model and convert it into route damage for use in the performance model.

MITRE's effort in this program has materially aided in planning and providing for future survivable communications systems. Computer programs developed in the past, or under development now, will make it possible to evaluate networks under any conditions of nuclear attack. By simulating different hardness criteria for the various facilities under these attack conditions, or by varying the routing of the networks, it will be possible to determine optimum trade-offs between

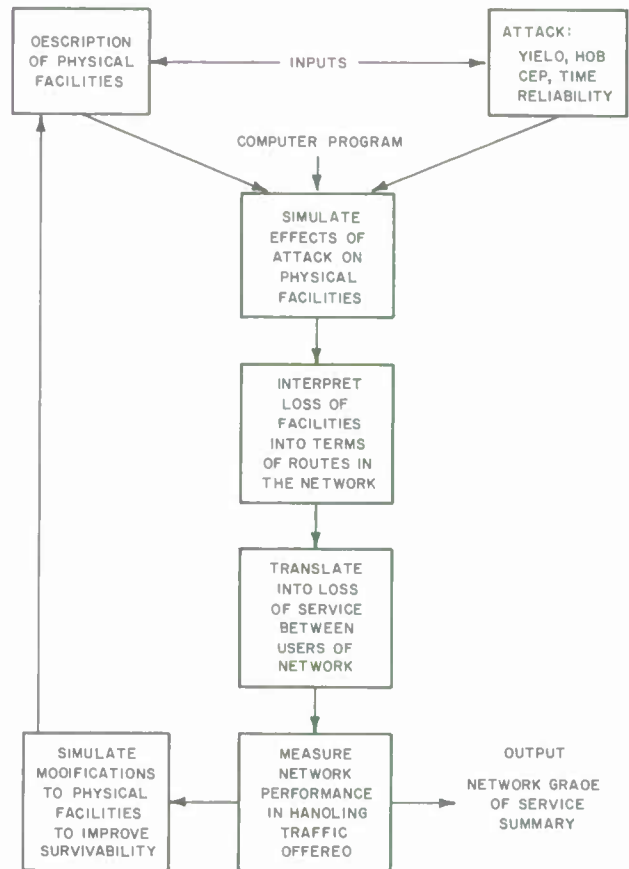

The KILLCOM communications survivability analysis program accepts a physical description of all facilities and specified attack parameters and produces a grade of service summary and pinpoints the vulnerability of any particular facility in the network.

hardening, redundancy, dispersal, and mobility of facilities so that maximum survivability can be achieved in future systems at a minimum cost.

DOCUMENTATION

Bussgang, J. and Leiter, M. "Error Rate Approximation for Differential Phase Shift Keying," *IEEE Trans. Comm. Sys.* CS-12, March 1964; see also ESD-TDR-63-472 (Unclassified).

- Charney, H. R. and Leiter, M. *A Suggested Technique to Secure a Decreased Error Rate in the BUIC Communications Facility*, TM-3698, The MITRE CORP., August 1963 (Unclassified).
- Graves, M. E. *MATCHPOINT I and MATCHPOINT II Computer Programs, Description and Operating Instructions*, TM-3976, The MITRE CORP., April 1964 (Unclassified).
- Greim, R. E., Menges, W. R. and Nelson, F. N. *Comparative Performance Evaluation of Digital Data Modems for HF Radio*, ESD-TDR-64-631, in press (Unclassified).
- Hamburger, P. *Efficiency of a Routing Scheme in a Mobile Data Processing Communication Network*, ESD-TDR-64-635, December 1964 (Unclassified).
- Kelly, J. P. and Mercurio, J. F. *Comparative Performance of Digital Data Modems*, TM-3037, The MITRE Corp., April 1961 (Unclassified); Supplement 1, August 1961 (Unclassified).
- O'Neil, D. R. *Error Control for Digital Data Transmission over Telephone Networks*, TM-4113, The MITRE CORP., November 1964 (Unclassified).
- Steeves, E. A. and Titus, D. W. *KILLCOM, A Simulation for Analysis of Survivability of Large Communications Networks*, SR-100, The MITRE Corp., December 1963 (Unclassified).
- Stine, L. L. *RF Power Allocation for a Unified Telemetry System*, ESD-TDR-64-104, June 1964 (Unclassified).
- Willard, D. G. and Wagner, P. E. *TINA, A Telephone Impulse Analyzer*, TM-3038, The MITRE Corp., April 1961 (Unclassified).
- Zierler, N. *Boolean Embeddings of Orthomodular Sets*, SR-108, The MITRE Corp., 1964 (Unclassified).
- Zierler, N. *Error-Correcting Coder-Decoder: Summary of Results of Phase I*, TM-4104, The MITRE Corp., October 1964 (Unclassified).

IV ENVIRONMENTAL FACTORS

The characteristics of the medium through which radar, optical, and communications signals are propagated have a direct effect on system accuracy and reliability. The objective of the environmental studies conducted by MITRE is to gain a quantitative understanding of the influences of the environment on the design and performance of information and communication systems.

Such information can provide to the designer and user the means for compensating for, correcting, or exploiting these environmental effects. Particular attention is centered on:

Electromagnetic propagation in the troposphere. Design and testing of a line integral refractometer for surface measurements.

A laboratory investigation of a method for reducing the detrimental effects of flame plasma on electromagnetic propagation.

TROPOSPHERIC PROPAGATION

The variations of temperature and water vapor content in the lower troposphere create meteorological

conditions that may be classified as standard, anomalous, or turbulent. These conditions, if uncompensated, can produce significant errors in systems using electromagnetic propagation to measure the position, velocity, and acceleration of airborne vehicles. Each type of condition may limit the design specification of a particular system, or, in some cases, make possible the development of useful techniques such as forward scatter tropospheric communication. Therefore, a tropospheric propagation program was undertaken to supply data to ESD and MITRE systems engineers for their use in planning, selection, and evaluation of surveillance, control, and range-radar systems. Both analytical techniques and measurement equipment were developed.

For standard meteorological conditions, refractive index is predictable according to a tropospheric model. Since the conditions vary with time, and from one location to another, predictions are generally supported by radiosonde data or synoptic weather information. When anomalous conditions occur, for example due to a tem-

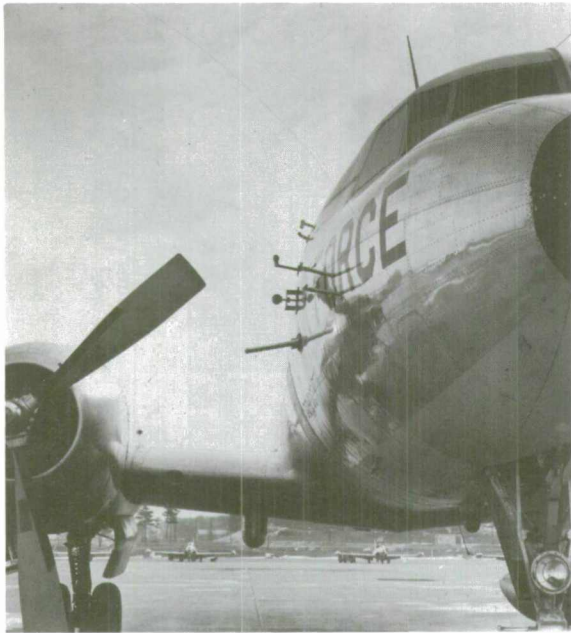

A Convair C-131B aircraft has been instrumented for real-time tropospheric measurement of temperature, pressure, relative humidity, index of refraction, and airspeed.

perature inversion of the mean lapse rate, propagation conditions become unpredictable. They may change to the extent that the propagation range and radar detection range at a particular elevation angle increases greatly, although at a different angle, these ranges may even be decreased. Turbulent conditions produced by evaporating moisture and rising air columns introduce variations which limit the accuracy and resolution of a system.

Even where propagation conditions may be predicted, the effect on the system of the predicted condition must be evaluated. For this reason a computer program was developed to accept the defined condition and determine the errors produced in distance and angle measurement. A C-131B aircraft was instrumented to measure real-time conditions and to permit rapid evaluation of their effect on a particular system.

Measurements are made of temperature, pressure, relative humidity, index of refraction, and

airspeed. Data is recorded on paper charts for visual inspection during flight, and on magnetic tape for the later analysis of high frequency effects. The heart of the aircraft recording system is a 14-channel analog-to-digital converter. Digital data is also recorded each second on punch paper tape that is later fed into the computer at MITRE and processed to correct for the effects of temperature and airspeed on the measurements. The corrected data is rapidly available in tabular form together with additional calculations of potential temperature, mixing ratio, and water vapor partial pressure. Selected parameters may be plotted directly from the computer.

A dual-channel refractometer mounted under the wing tip of the C-131B will permit the vertical index gradient variations to be recorded as a function of horizontal direction. This unique instrument will be used to investigate the fine structure of layers to understand better clear-air radar echoes and forward scatter propagation conditions.

These facilities have been used to evaluate the limitations in height finder radars for both ADC and FAA, to evaluate the limitation in correction techniques applied to these and AMR systems, and to measure the effect of anomalous propagation conditions on communications for ADC/NORAD. In addition, MITRE has been given the opportunity to work with AFCRL on their Wallops Island investigations of clear-air radar echoes, and also to support the Woods Hole Oceanographic Institution on their investigations of turbulence in the lower atmosphere.

In association with the RCAF, a series of experiments was conducted at an instrumented range in Canada to evaluate the accuracy of the analytical program and the aircraft measurements. The RCAF used a vertical interferometer to measure the angle of arrival of a microwave signal transmitted from an aircraft. At the same time our aircraft made measurements of the propagation conditions in the test area. Following these tests, the meteorological measurements were used together with the computer analysis to determine the expected angle of arrival of signals at particular times. These calculations were checked against

the extremely accurate experimental data provided by the RCAF. Results indicated that the overall error in comparative data was less than 10 percent of the effect to be measured. For example, for angles of arrival of approximately 1.7 milliradians, the difference between experimental and analytical results varied about ± 0.4 milliradians; the total bending error due to the troposphere was 3.7 milliradians or about 10 times greater.

At the request of ESD an evaluation of height-finder correction techniques was made with sites selected at Albany, New York, and Nantucket, Massachusetts. Daily radiosonde data was available from these sites for the month of November 1963. A computer program was established to convert the teletype radiosonde message into a digital definition of the vertical index of refraction and to calculate the cumulative bending along the ray as a function of height. Several different values of initial elevation were used. At both sites, the results showed bending for the low angle case to vary greatly from day to day. The rate at which bending occurred as a function of height appeared to agree with the predicted bending using an exponential model atmosphere. The bending determined by using either the surface-corrected model or the commonly used $4/3$ earth or constant K correction differed greatly from the actual bending as determined from the ray-tracing calculation.

While participating in clear-air radar echo studies, we made aircraft measurements of refractive index and temperature profiles at the position of reported clear-air layered radar echoes. The MIT radars at the NASA Wallops Island Range were used to determine the height and fine structure of observed echo layers. Analysis of aircraft data showed that index of refraction variations as large as 40 N units occurred within an altitude change of 300 feet at the height of the layer. In four out of five cases, a temperature inversion or a region of constant temperature with altitude occurred at the height of the layer. A thin haze layer was observed on one occasion at the reported altitude of the layer.

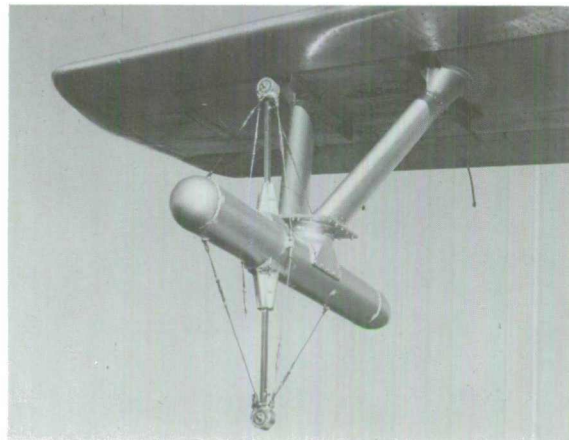

A dual-channel microwave refractometer mounted under the C-131's wing tip permits vertical index gradient variations to be recorded as a function of horizontal direction.

At the request of ADC/NORAD, aircraft measurements were carried out off the north California coast during December 1964. Specifically, data was required to determine the causes for the breakdown of communications between the ground and radar surveillance aircraft. This test demonstrated the quick reaction capability provided by a digital recording system on the aircraft. The punched-paper tape data was played back through a teletype printer. Within two hours following a flight, the data was available in tabular form for manual plotting. This capability made it possible to have graphs and partial analysis of the data available for briefings the following morning. The data clearly showed the presence of a duct at about 3500 feet over the ocean. When a radio signal was sent from the ground, the duct could cause the signal to be bent back towards the ocean and thereby stop the information transfer to aircraft above the layer.

During the latter part of 1964, discussions were started with representatives of the Woods Hole Oceanographic Institution regarding plans to conduct a systematic study of the turbulence generated by the interaction of the ocean and the wind over the ocean. This work was supported by the

Army Signal Corps, Office of Naval Research, Bureau of Naval Weapons, and with research groups from various universities. The ESD-MITRE aircraft was requested to obtain measurements from the surface to several thousand feet. To enhance the development of the turbulent model, we were asked to measure the refractive index in the tradewinds and plot the motion, temperature, and humidity fields around the test site. Tests will begin in February 1965, at the island of Aruba in the Netherlands Antilles, a site chosen because of the great steadiness and strength of the wind, the absence of rainfall, and the absence of tidal oscillations of the sea surface.

LINE INTEGRAL REFRACTOMETER

The accurate measurement of radio path lengths through the atmosphere required for geodetic positioning, radio guidance, radar tracking, and orbital determination necessitates a correction for the refractive effects of the atmosphere. The principal effect is a reduced propagation velocity caused by water vapor content and oxygen-nitrogen density, both of which vary as a function of position along the radio path. A secondary effect on range measurement is ray bending due to re-

fractivity gradients. The Central Radio Propagation Laboratory of the National Bureau of Standards (NBS) has given considerable attention to tropospheric refractive effects, including the limitations that propagation places on radar measurements. Using a particular tropospheric model in conjunction with measured values of the refractive index of the surface of the earth compared with calculations using radiosonde refractive data, NBS has reported that range can be corrected for refractivity to an accuracy of one to three percent. The Line Integral Refractometer method being developed at MITRE measures the refractive index over tropospheric line-of-sight paths in a manner which, in comparison, may ultimately provide corrections improved by one order of magnitude.

The Line Integral Refractometer determines the refractive qualities of the atmosphere between the transmitting and receiving equipment. The measurement permits a correction to be made for the small delay in radio signal waves caused by refraction. The transmission of two frequencies, one above and the other below the radio absorption frequency of a particular atmospheric component, results in a differential phase shift due to dispersion produced by the absorption characteristic. Measurements of this differential phase shift can be used to evaluate the line integral over the path by using a theoretical relationship between dispersivity and refractivity. Since the percentage composition of oxygen, nitrogen, and the other dry constituents of the atmosphere is the same for all densities, differential phase measurements of the oxygen component can be scaled in proportion, so that measurements of only the oxygen and water vapor components are required.

As part of a test program at MITRE, a dual-frequency transmitter and two identical dual-frequency receivers were constructed for measurements of differential phase about the water absorption line at 22 Gc. The equipment was mounted in truck vans for field evaluation of line-of-sight paths. The two frequencies used were 15.6 Gc and 31.2 Gc. (Construction of similar equipment for measurements about the oxygen



Line integral refractometer receivers aligned for reception of simultaneous, dual-frequency transmission at 15.6 Gc and 31.2 Gc. Each receiver measures the differential phase shift between the signals that are introduced along the path by the water vapor absorption at 22 Gc.

absorption line at 60 Gc has been initiated.) Water vapor measurements were made over a number of different paths in New England and Tennessee. These tests demonstrated that the average differential phase shift changed with atmospheric water vapor content according to theoretical predictions. Nevertheless, a large time-dependent, Gaussian-distributed fluctuation about the mean was generally found to be present. By physically separating the receivers in the beam of the common transmitter, the fluctuations were observed to be related to a sluggish structure in the atmosphere that moves with the mean airflow across the path. Tropospheric propagation theories, involving turbulent dielectric structure as blobs or layers, explain the nature of the observations qualitatively, but do not explain the wide dynamic range of variation of the observed fluctuations. The test program has also furnished new data on the ultimate coherency of propagation of microwave signals differing in frequency by 15.6 Gc over paths of several miles. Specifically, the random separation of the received wave fronts was observed to be typically 1/100 of a centimeter.

For the purposes of radio path correction, smoothing of the fluctuations in the time domain is required for fixed paths, and this results in spatial smoothing for moving paths. Power spectral analysis of available data indicates that smoothing periods of 10 to 1000 seconds are required to achieve accuracies of 1 percent in humidity. Thus, the Line Integral Refractometer development program has demonstrated a concept which potentially could provide high accuracy of path length correction.

The program has also measured the coherency of propagation of microwaves. (It may be anticipated that the principal use of the Line Integral Refractometer will be in the calibration of precision radio distance-measuring devices.) In addition, data which is of interest in the field of radio meteorology has been gathered on the forward scatter of rain, snow, and clouds.

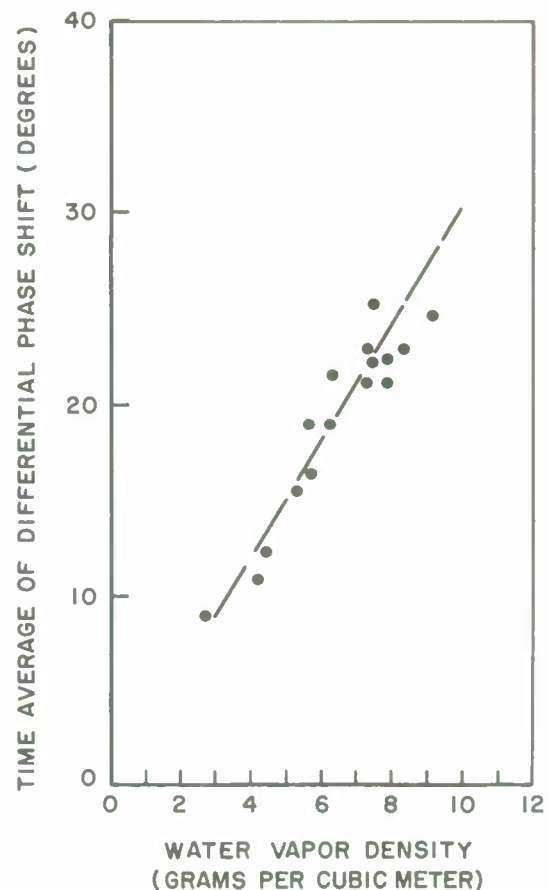

The effect of the density of water vapor in the atmosphere on the differential phase of line-of-sight transmissions at 15.6 Gc and 31.2 Gc is shown by this initial data, recorded on a 20.8 kilometer path.

FLAME PLASMA

The launch and reentry portions of an airborne vehicle's trajectory have a common denominator—the generation of plasma. The plasma sheath of reentry and the flame plasma of the exhaust plume both interfere with the electromagnetic linkage of the vehicle with the ground station, and this results at times in blackout, tracking errors, telemetry and communication malfunction, as well as jeopardy of the command-destruct operation. Range testing of new vehicles, radio guidance of missiles, and in-flight retargeting are subjected to plasma interference. Because of the need to maintain an effective linkage between a station

and an airborne vehicle, the interaction of an electromagnetic wave with flame and reentry plasma has received considerable attention.

The nature of this interaction is controlled primarily by three basic parameters: plasma frequency, signal frequency, and collision frequency. For a given signal frequency, decreasing the plasma frequency always reduces the attenuation and reflection. Increasing the collision frequency may produce either increases or decreases in attenuation. The reflection coefficient is decreased as the collision frequency is increased. Theoretical studies indicate that the addition of micron size, highly charged particles to the plasma could increase the collision frequency and/or decrease the plasma frequency.

Experimental work is being carried out to verify this theory. It consists basically of measurements of the RF attenuation and reflection characteristics of a flame under various conditions. The flame used in the laboratory is generated with acetylene and oxygen and is seeded with sodium or potassium salts to produce a flame plasma. The rocket exhaust attenuation is, in part, caused by alkali contamination of the fuel.

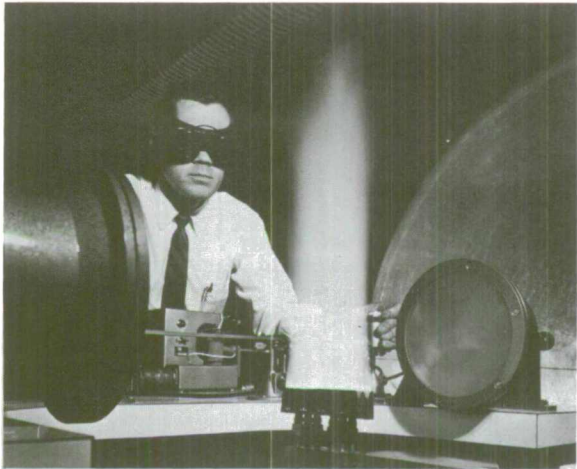

A 35 Gc phase bridge is being used to measure attenuation, phase shift, and reflection of a flame seeded with sodium chloride to simulate flame plasma.

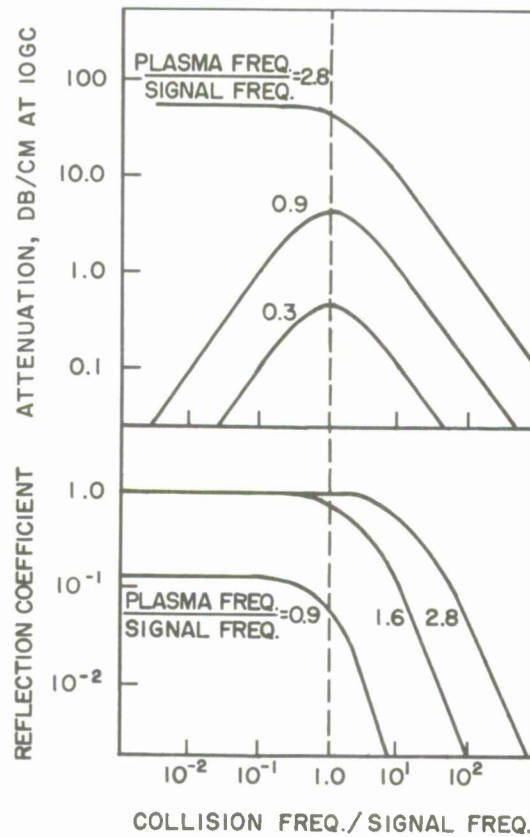

In a flame plasma, attenuation and reflection losses may be decreased by increasing the collision frequency, even if the plasma frequency is greater than the signal frequency. This is shown in the right hand region. In the left hand region, plasma frequency exceeding signal frequency results in virtually complete signal reflection.

Measurements of flame attenuation, phase shift, and reflection are made with two microwave phase bridges at frequencies of 10 Gc and 35 Gc. These measurements are used to calculate the plasma frequency and collision frequency in the flame. Experiments with flames of various plasma frequencies have verified the initial theoretical predictions. These measurements were all made at the normal collision frequency of the atmospheric flame. Presently, experiments to vary the collision frequency through the introduction of charged particles are being implemented.

The first step in this program is the introduction of small uncharged particles. These become

charged through thermionic emission of electrons, the amount of charge acquired being a function of particle size, material, and temperature. The determination of the relationship of these parameters is under way and will be followed by the introduction of particles which are charged prior to their introduction into the flame.

DOCUMENTATION

Crane, R. K. "Canadian Reflection-Interferometer Elevation Angle Error Measurements," *Proc. Second Tropospheric Refraction Effects Tech. Rev. Meeting*, Vol. II, April 1964 (Unclassified).

Crane, R. K. *Estimates of Errors in Mistran Data Due to Atmospheric Refraction*, TM-3422, The MITRE Corp., October 1962 (Unclassified).

Crane, R. K. "Ray Tracing in Cloud Cross Sections for a Long Baseline Interferometer," *Proc. Third Tropospheric Refraction Effects Meeting*, Vol. I, ESD-TDR-64-148, November 1964 (Unclassified).

Galbiati, L. J. "ESD Tropospheric Refraction Effects Task," *Proc. Second Tropospheric Refraction Effects Tech. Rev. Meeting*, Vol. I, ESD-TDR-64-103, March 1964 (Unclassified).

Hoffman, J. *Control of Plasma Collision Frequency for Alleviation of Signal Degradation*, TM-4097, The MITRE Corp., October 1964 (Unclassified).

Hoffman, J. *Electronic Tracking Errors vs. Plasma Effects*, ESD-TDR-64-74, August 1964 (Unclassified).

Richardson, H. "Field Test Results of the Line Integral Refractometer," *Proc. Third Tropospheric Refraction Effects Meeting*, Vol. I, ESD-TDR-64-148, November 1964 (Unclassified).

Richardson, H. and Sullivan, J. "Line Integral Refractometer," *URSI-IUGG*, NBS, Boulder, Colorado, June 1963 (Unclassified).

Rowlandson, L. G. *The Effect of Multipath Propagation on Passive Correlation Radar Systems*, TM-3391, The MITRE Corp., August 1962 (Unclassified).

Rowlandson, L. G. *Summary Report on the Limitations in the Use of Height-Finding Radars for an Air Traffic Control*, TM-3237, The MITRE Corp., January 1962 (Unclassified).

Sullivan, J. and D-82 Staff *Line Integral Refractometer*, SR-112, The MITRE Corp., August 1964 (Unclassified).

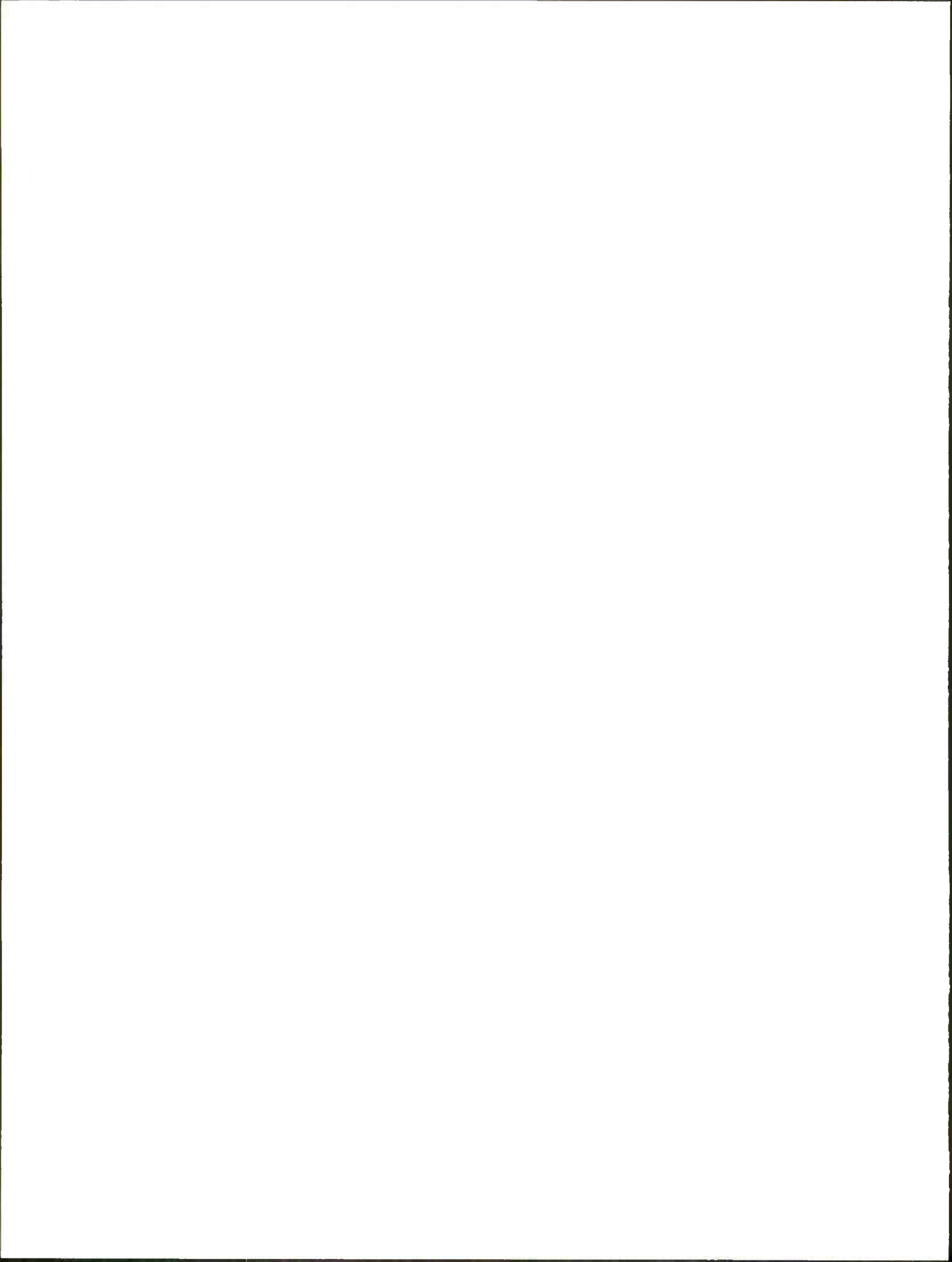

V COMPUTER AND DISPLAY TECHNOLOGY

The MITRE computer and display technology has two basic objectives:

To acquire and maintain a current and expert knowledge of the state of the computer and display technology art, through first-hand contact with advanced development, in order to advise MITRE and ESD systems engineering and advanced planning organizations.

To identify and explore new advances in computer and display technology in order to gauge their relevance to the future needs of operational computer-based information systems.

In pursuing these objectives, MITRE carries on a program of experimental research and development in selected areas of the computer and display technological fields. The areas are selected so that the studies conducted contribute to the maintenance of a sound technical foundation for ESD's system design and acquisition activities. As a natural byproduct, however, the selected projects have themselves resulted in innovation within their respective areas.

The program is divided into three major areas of work:

Display devices,

Computer device techniques, and

Phoenix general purpose digital computer.

The display devices project has investigated a new idea in the implementation of three-dimensional displays.

The computer device projects investigate new components and the materials and processes required for their fabrication. The projects are in the fields of circuits and circuit components, memory devices, and optical and electro-optical devices. The results of the studies have provided new and simple techniques for increasing the performance of computing systems in the areas of input devices, information storage, display, and logic circuit components.

The Phoenix computer project has as its goal the development of a flexible, time-shared, multiple-user computer. The uses of the computer will include:

Evaluation studies of machine and human data processing ;

Evaluation of advanced machine organization and systems design ;

Exploration of the potentialities of the time-sharing concept, together with the technical problems involved in its implementation ; and

Provision of a powerful addition to the capabilities of the Systems Design Laboratory.

The knowledge gained from these projects enables the prediction of advances in system technology and provides the kind of capability necessary to fulfill future operational needs.

THREE-DIMENSIONAL DISPLAY

An experimental project, exploiting a new idea in the implementation of three-dimensional displays, demonstrated a display effect similar to that produced by existing displays of the oscillating or rotating screen type. It makes possible, however, a simpler, lighter weight, and more reliable device. There are several interesting applications for such a device; it could be used for spatial position representations of real objects such as missile positions and trajectories and aircraft positions for traffic control purposes. It could be useful for analysis of such things as abstract mathematical relationships, radar returns, and human speech signals.

The system uses a flexible membrane mirror caused to oscillate about a flat reference configuration, becoming alternately concave and convex, at a rate higher than the flicker fusion frequency of the eye. The mirror is combined with a two-dimensional pattern generator, such as an oscilloscope tube face, upon which an appropriate periodic pattern is displayed in synchronism with the mirror motion. When viewed in the vibrating mirror, the pattern appears to possess depth as well as height and width. The depth effect has associated with it the usual three-dimensional cues of binocular disparity, parallax, perspective, and obscuration.

When the mirror is flat, it is equidistant from the object and the image. As the mirror becomes

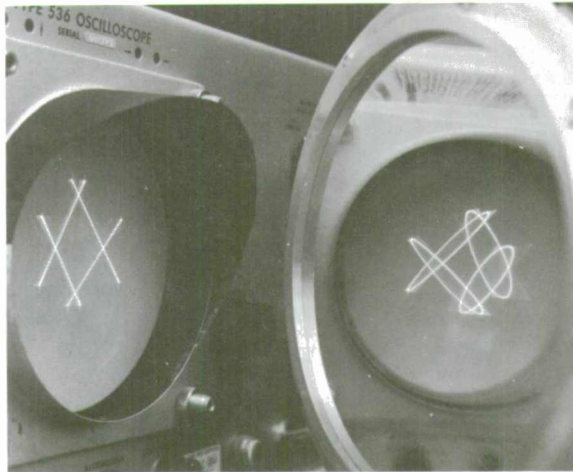

This three-dimensional display of a two-dimensional pattern is produced by reflection of an oscilloscope trace in an oscillating membrane mirror.

convex, the image advances toward it, and as the mirror becomes concave, the image recedes. If the object is on a flat surface, such as a trace on a cathode ray tube face, and if the mirror deformations are produced cyclically at a rate too high for the eye to resolve, then the image of the surface appears as a blur throughout a well-defined volume of space. The actual mirror motion is very small compared to the depth which is achieved in the image. The excursion at the center of the mirror is typically less than 1/16 inch for a seven-inch diameter mirror. The depth effect is due almost completely to the slight changes in mirror curvature.

The display volume is like a three-dimensional blackboard throughout which visual information can be displayed, provided the appropriate time-varying display is presented upon the object surface. For example, in the simple case that a steady light spot is displayed upon an otherwise dark tube face, its image will appear essentially as a straight line perpendicular to and behind the mirror. If the spot travels along the tube face in synchronism with the mirror motion, the orientation of the image line will change. Furthermore, if a phase change is introduced between the spot and the mirror motions, the image line will

develop into an ellipse or circle. By generalizing these simple situations, one can produce more complicated patterns in the image space, provided that the required two-dimensional patterns are generated in the proper sequence.

A mathematical analysis of the optical image forming properties of deformed membrane mirrors is being conducted, and an experimental study is being made of electrostatically driven membrane mirrors as an alternative to pneumatic driving. Optical methods to bring the spatial image in front of the mirror for accessibility are also being examined. A research model is under construction for evaluation as a psychological laboratory tool for studying depth perception.

COMPUTER DEVICE TECHNIQUES

Research and development projects in computer devices are divided into three areas: circuits and circuit components, high-speed computer memory, and optics and electro-optics. The research and development projects in each area have limited goals, defined so that in no way do these projects represent an unnecessary duplication of known activities pursued elsewhere, but rather a complementary effort to extend and exploit new technology for possible application to computer system requirements at MITRE/ESD.

CIRCUITS AND CIRCUIT COMPONENTS

In early 1961, a program was initiated at MITRE to exploit the speed of planar and epitaxial solid-state devices and new, high-speed switching elements in logic circuits. Since the switching speeds sought were in the nanosecond range, the program was broadened to include development of circuit assembly and packaging techniques, thin-film techniques for passive components and device connections, transmission-line interconnections, and passive component reliability, in addition to the basic circuit design. As the program matured and logic circuit parameters were measured in the laboratory, a digital test assembly was designed to provide a testing environment for the circuits.

At the time circuit development was initiated, the fastest logic circuits available commercially

were the 20-megacycle family of "H-Pacs" manufactured by Computer Control Company. A special-purpose, serial computer using the H-Pacs was designed, assembled, and checked out for performing block coding and decoding operations. Acoustic delay lines were used for memory. One hundred and twenty H-Pacs, or the equivalent of approximately 1000 of the simpler, fast-logic circuits (individual gates and flip-flops) were used. This computer effort was an initial test for the concepts of serial machine organization with delay-line memory, later used in the digital test assembly.

After the special-purpose machine was built, a general-purpose, serial computer capable of operating at a bit rate of 100 megacycles was logically designed. The goal was to implement this computer with the proposed family of high-speed logic circuits, if their performance reached the design goals. Ten delay lines and a 0.5-microsecond magnetic memory were required. Most operations would be executed in 1.0 microsecond.

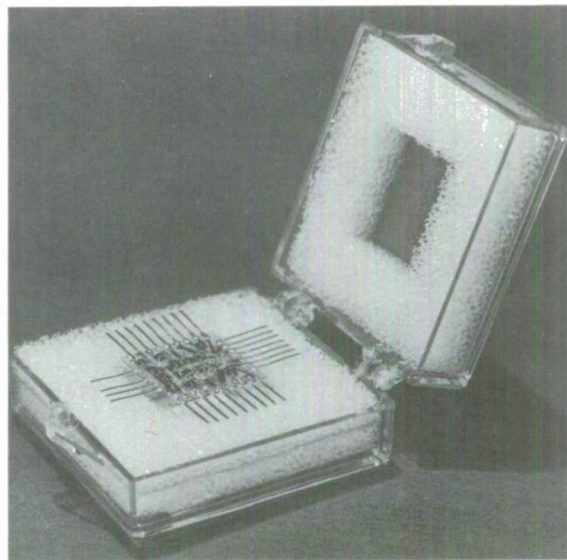

On the 0.5 by 0.5 inch glass substrate are ten vacuum-deposited nichrome resistors, gold conductor lands, ten chip transistors, and four chip diodes. The OR-gate high-speed logic circuit is given complete electrical tests in this form before being encapsulated in epoxy.

Circuit Design and Packaging

A transistor, operated as an emitter follower, with a tunnel diode in the base circuit was utilized to achieve rapid switching and level fixing as well as amplification with built-in reshaping. Backward diodes were employed as gate inputs to transistor current steering and switching stages. The switching characteristics of the emitter follower and the combined, current-steering emitter-follower circuits were studied on the analog computer.

The family of circuits which were developed included non-inverting AND and OR gates, inverting amplifiers, set-reset flip-flops, and clock-signal generation and distribution circuits.

The circuits were made using both discrete components and thin-film components. The discrete components were soldered to etched, copperclad, glass-epoxy, circuit boards approximately one-half inch square. Thirty-five of the small circuit boards were mounted on a logic card which contained strip line interconnections. Eight logic cards plugged into a back panel wired with twisted pairs.

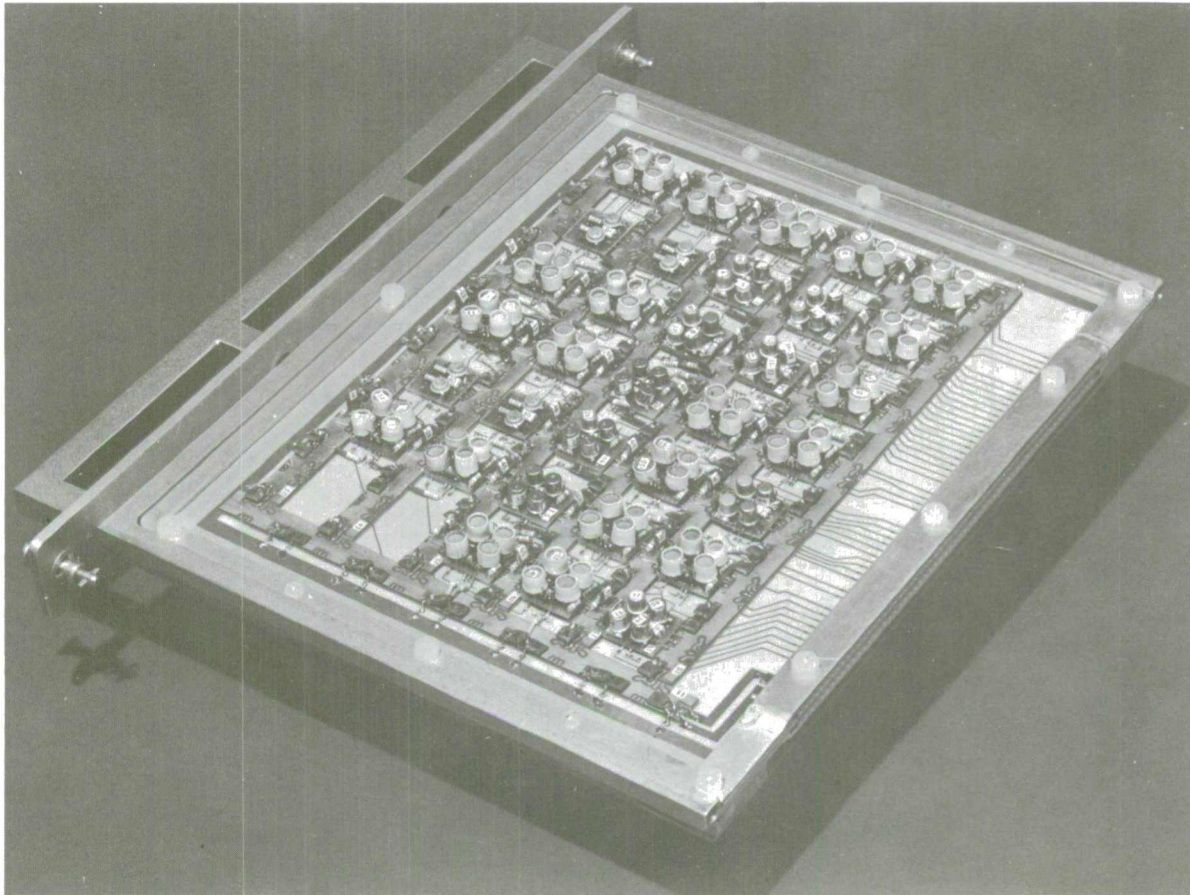

There are thirty-three individual logic circuits mounted on this 6 by 8 inch logic card for the digital test assembly. The card is fastened in a supporting frame with a multiterminal connector along the right edge which plugs into the back panel of the test assembly.

The circuits which used thin films for resistors and circuit connections had the same lead arrangement and were mechanically and electrically interchangeable with the circuits made with discrete components. The resistors were vacuum-deposited nichrome and the conductor surface was vacuum-deposited gold. Chip semiconductor devices were bonded to the appropriate conductor lands, and external leads were bonded around the edges. The entire substrate assembly was encapsulated in a cast epoxy package. Complete, step-by-step fabrication schedules and specifications were determined for all the chemical, physical, and vacuum processing steps required to make the high-speed circuits for the digital test assembly. Mechanical jigs and fixtures were made to facilitate electrical, in-process tests of the circuits.

Digital Test Assembly

The purpose of the digital test assembly was to test the circuit family by performing and checking a high-speed addition. It contained 286 small circuit boards and space for three delay lines on the eight logic cards. There were two, eight-bit, 100-megacycle shift registers; an eight-bit parallel adder with anticipated carry; decoder circuits; clock distribution circuits; a binary counter; and control logic. The logic levels were clocked every fourth stage in most cases, and the clock signal was used in the gates in the same manner as a logic variable. The logic delays at each circuit stage was typically less than two nanoseconds. Measurements indicated completed, eight-bit addition in 15 nanoseconds.

Thin-Film Passive Components

Vacuum-deposited, nichrome resistors were suitable for use with the high-speed circuit family. In order to study their reliability, groups of ten resistor test circuits were placed on constant power aging. Each group was at a different power level ranging from the design value of 0.1 watt to accelerated power-aging levels. The only device failures, after 1000 hours, occurred because of catastrophic changes in the mechanical integrity of the package at the very high power levels.

Thin-film capacitors possessing excellent high-frequency properties were made with alumina as the dielectric. The alumina was vacuum-deposited by focused, electron-beam heating and evaporation of a sapphire. Single-layer devices were made with approximately one-microfarad capacity per square inch, and with working voltages up to 50 volts.

Thin-Film, Active Components

Epitaxial silicon films, six to ten microns thick, were grown by the silane decomposition method on the face of small discs of artificial sapphire,

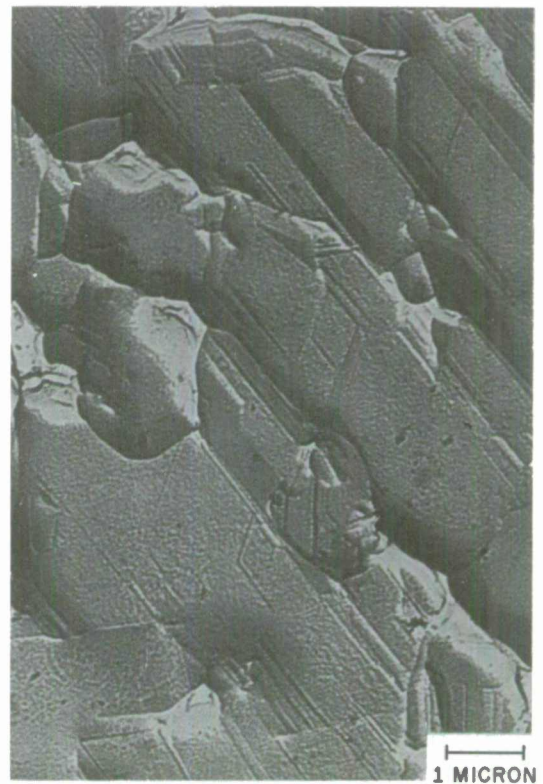

This electron micrograph of the surface of a silicon film grown epitaxially on sapphire has a magnification of 10,000 times. The ridge lines are the boundaries between adjacent silicon crystallites. The dislocation lines and triangles are visible in each crystallite. The silicon film is six microns thick, and it is oriented in the "111" direction.

0.25-inch in diameter. The films grew in the "111" direction. They were p-type and had a resistivity in the range of one to ten ohm-centimeters. They also had a very high dislocation count making it impossible to diffuse junction devices in them. However, a few field-effect transistors have been made in the material with transconductance of approximately 200 micromhos, and dynamic source-drain resistance of 5000 ohms at zero gate voltage.

The epitaxial temperature and growth parameters have been determined for the silicon-sapphire system, for various orientations of the sapphire substrate. The available sapphire boules have poor crystalline properties, however, which prevent fabrication of higher-quality silicon films.

HIGH-SPEED COMPUTER MEMORY

Present-day memory elements do not have the operational speed capability of the very fast circuits used in computer logic. Consequently, the circuits intended for the arithmetic and control units in a computer must also be used for storage. Since more bits are stored, at any given instant, than are being operated on, this type of storage makes inefficient use of the circuit capability and is very expensive. Because of the cost, there are usually only a few flip-flop storage registers of this kind in any machine, and they serve to buffer the high-speed logic to the slower (larger) main memory. Possible approaches to achieving large, high-speed memory at a reasonable price involve the use of electromagnetic delay lines and thin magnetic films.

Electromagnetic Delay Lines

Acoustic delay lines are not suitable for delaying pulses with rise times of approximately one nanosecond. Coils of coaxial cable are suitable to a certain extent, but they are bulky and tend to have excessive rise times. If the size of the cable is reduced, the bandwidth decreases and the losses increase. As a result of a study of the electromagnetic wave propagation properties of helical delay lines, in which the IBM 7030 computer was used for evaluation of the phase-dispersion expressions,

a shielded-helix configuration was proposed. It was investigated analytically and experimentally and resulted in practical, low-loss, delay elements.

The delay lines consist of a helix wound in the annular region between two coaxial, conducting shields. A typical line has a delay of 140 nanoseconds and a rise time of less than 0.5 nanosecond. This implies an inherent storage capacity of approximately 300 bits. These lines have a delay-to-rise-time ratio approximately 50 times greater than any commercially available delay elements of comparable volume.

To store for a longer period than the delay time, the bits must be recirculated through the line. This is accomplished with a single transistor

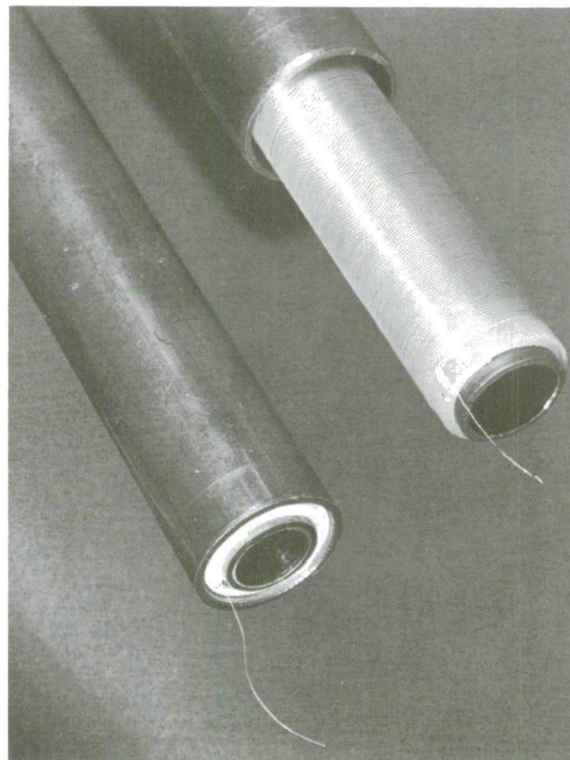

The diameter of the outer conducting cylinder of these helical delay lines is one inch. The helix is wound on the insulated, inner cylinder, and then inserted into the outer shield. These lines have a delay-to-rise-time ratio approximately 50 times greater than any commercially available delay elements of comparable volume.

amplifier. In one 50-hour test, a 25-bit word was recirculated more than a trillion times without error.

The delay lines are easily assembled and the design is adaptable to mass fabrication techniques. Projected estimates are that within the same volume, weight, and power restrictions, a delay-line memory with the same capacity as a thin-film, scratch-pad memory, will be two or three times faster, and possibly one-tenth as expensive. Logic and control circuits are included in the estimation.

Magnetic Thin Films

This program was initiated to study and develop an engineering model for the rotational switching of a magnetic film, and ultimately to study the feasibility of a large, magnetic-film memory to operate with a cycle time in the range of 30 nanoseconds.

An all-metal vacuum system was modified and equipped for deposition of thin film of permalloy onto three-inch-square glass substrates. The films had square loops, and coercivities and anisotropy fields of approximately two oersteds.

An adequate engineering model of high-speed, rotational film switching does not exist. It was

necessary to construct a test equipment similar to a memory system in order to study the output signal. The relationship must be known between amplitude and shape of the output signal, and the amplitude and rise time of the driving current pulses. The test equipment assembled to aid in this characterization was called the Disturb Test Facility. It applied drive pulses of known amplitude and rise time to write a bit in a memory location. Then it shifted to adjacent memory locations and wrote the opposite bit in them from zero to twenty million times. Finally, it returned to the initial location and read out the disturbed bit. The output signal was normally displayed on an oscilloscope with 2.2-nanosecond rise time, but it could also be displayed on a sampling oscilloscope and the entire disturb cycle could be repeated after each sample. Thus, the output signal was observed, as well as its degradation, as the number of adjacent disturbs was increased.

Circuits for generating the digit and word current pulses, with amplitudes up to one ampere and rise times of four nanoseconds to be consistent with 30-nanosecond memory cycle time, were designed and built for the Disturb Test Facility. The same circuits would be suitable for memory. The sense amplifier gave a sensitivity of 100 microvolts per centimeter on the oscilloscope display, and was of a greater capability than would be required in the memory. A common digit-sense strip line was used in the assembly that held the magnetic film. A fast, sense-gate circuit was designed and built to protect the sense amplifier. It was opened by the logic in the Disturb Test Facility only during the interval when an output signal might occur.



This illustration shows the uniformity of a 3 x 3 inch, thin magnetic film. The mountains and valleys are at the boundaries between differently magnetized areas, which occur when the film is in a partially switched state. The apparent third dimension corresponds to a vertical component of magnetic field.

OPTICS AND ELECTRO-OPTICS

Optical and electro-optical techniques can be used for performing special computer input and output functions, and for generating and reading large, secondary-memory files. The development projects are directed toward improving performance of peripheral equipment in present-day computing systems. Areas in which improvement is possible, and needed, include input de-

vices to scan graphs, maps, etc.; medium-sized bright displays suitable for real-time, man-machine interaction; and recording techniques for mass, read-only memories with very short write processing time. The associated device developments are called, respectively DI-SCAN, Light Switch, and Optical Recording with Lasers.

Optical and electro-optical techniques are being investigated widely for possible use in performing the mathematical operations in a computer. One approach exploits the spatial coherence of laser light sources. Another approach exploits the semiconductor light source and its optical interconnection with a variety of semiconductor photodetectors. The research at MITRE in this area is concerned with a basic study of the bulk, photoresistive properties of doped silicon.

Optical systems for projection of information stored on film or microfilm are frequently required in military system control centers. Systems of plane mirrors are used in projectors for inverting and rotating the image field. A synthesis technique which permits rapid design of mirror systems is the subject of the final activity in this area.

DI-SCAN

The DI-SCAN tube is the first of a class of image dissectors which provide, within the same tube envelope, means for obtaining simultaneously, multiple electrical output signals directly proportional to the light intensity at particular points in the image. The characteristics of the tube were specified by MITRE, and five of them were made by a leading tube manufacturer. The tube is three inches in diameter, 15 inches long, and has a 35-pin base. The face is flat and has deposited on its inside surface an S-11 photocathode. Behind the photocathode is a drift space at the end of which is the target aperture plate with three, 0.005-inch holes centered at the apices of an equilateral triangle 0.010-inch on a side. Behind the aperture plate is a "fence" and electrostatic deflection structure which directs each emergent beam of electrons to its own independent electron multiplier.

Consequently, three output signals corresponding to the intensity of the image at three known adjacent points are simultaneously available.

Test equipment was assembled to drive the tube and translate the three output signals into logically meaningful digital statements about the image. This digital information will be available to the Phoenix computer. A logical network was included that measured the slope of a line and gave the position coordinates of both edges of the line. Once a line was crossed, the tube could be caused to follow the line, and give both digital-position and digital-slope information as it progressed. The availability of both position and slope information at the same time, with no requirement for intermediate storage, scanning, and computation, makes DI-SCAN an attractive device for optical computer input.

No crosstalk between any of the three channels could be detected. The test equipment was also used to study the focusing and deflection characteristics. The use of the tube, in its present embodiment, is feasible for generating data inputs from graphs, maps, and photographic storage media.

Light Switch

The light switch is a cellular, non-linear, light-amplifying device suitable for incorporation in large arrays in large screen displays. Onto the array would be projected a low-intensity image from a conventional, high-resolution, cathode-ray tube. The display would be amplified at the viewing screen. In certain operational modes, the light-switch screen should be able to store the displayed information for many frame times. Normally, the storage time would only be a single frame time. This device also has application as a penlight-activated, read-only memory whose information is available to a computing system immediately upon being written. There is no latent period associated with development.

Each cell is a cylinder with a photocathode at one end, vacuum space in the middle, and non-aluminized phosphor-coated anode at the other

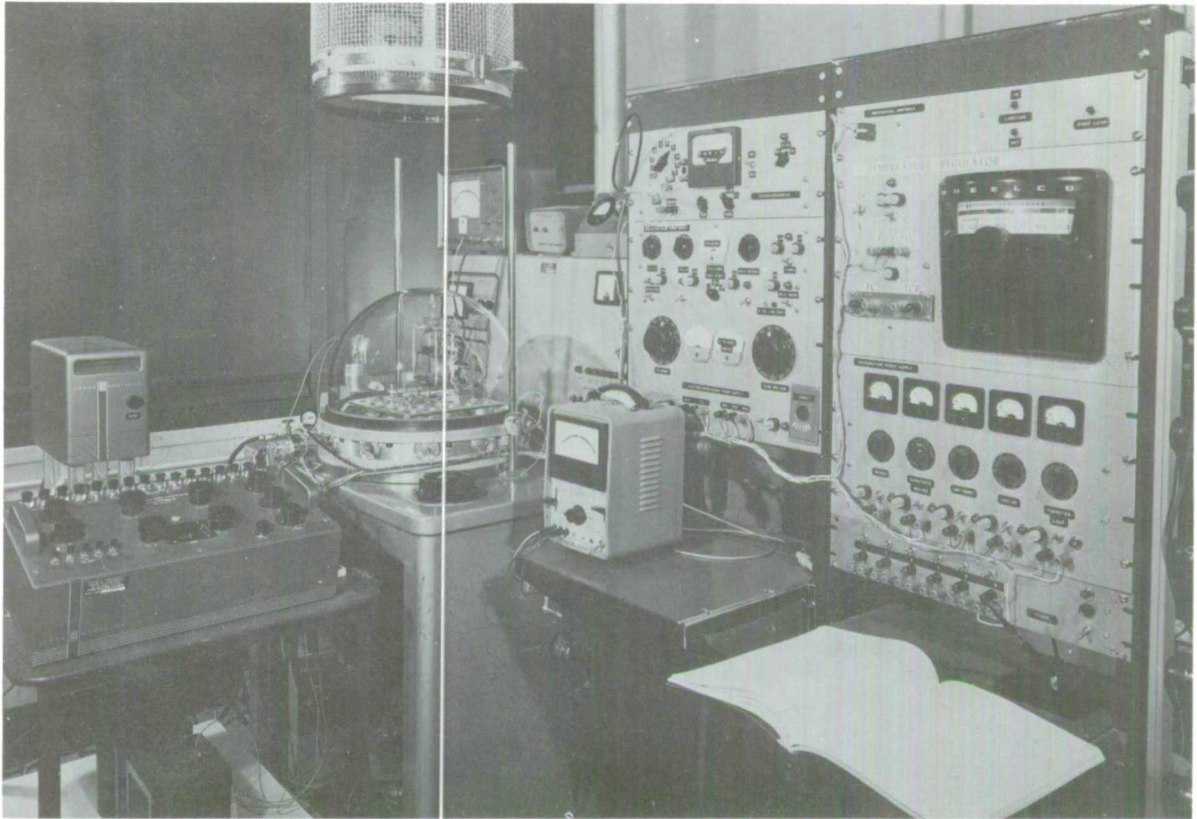

The bell jar vacuum system is used for measuring the system pressure, outgassing some of the interior parts, heating and controlling the temperature of the substrate, heating and evaporating the various source metals, and measuring the resistance of the films during deposition.

end. The phosphor emits light forward to be viewed, and backward as well. The geometry of the cell is chosen so that as much of the back-emitted light as possible is intercepted by the photocathode. There is a positive optical feedback, and the cell should "turn-on" if sufficient accelerating voltage is applied.

Before the required close spacing of photocathode and anode can be achieved, the photocathode is first formed in a high-vacuum enclosure at a position remote from the phosphor-coated anode assembly. The phosphor is protected during the introduction of cesium vapor for photocathode formation, since it is not aluminized and

would be poisoned by the cesium. The photocathode is then transferred to the anode assembly, under high vacuum, and ultimately must be sealed to it. Single cells have been made by this technique in an all-glass, high-vacuum system. The cesium-antimonide photocathodes were very efficient, but problems remained with maintaining phosphor efficiency throughout the processing steps.

The geometry of the device can be scaled. The experimental light cells were made with 0.1-inch and 0.5-inch diameters. Projected sizes of 0.020-inch, or 50-line-per-inch resolution, are not unreasonable.

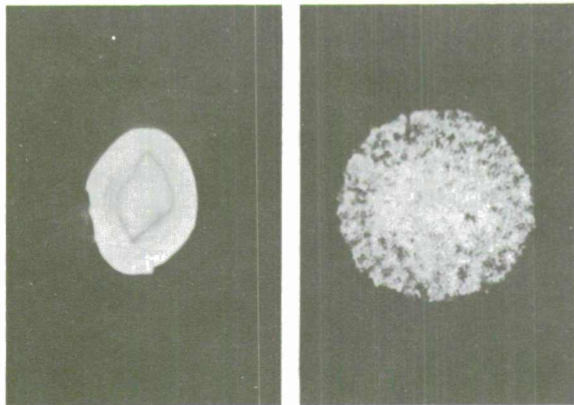

Holes in thin films formed by ablation with the focussed light from a Q-switched ruby laser. The hole in the left hand figure has an approximate diameter of 0.0016 inch; it is an evaporated gold film of six percent transmission, and it required a 50-nanosecond, 11.0-micro-joule pulse. The hole on the right has a diameter of 0.003 inch; it is formed in a smoked carbon film of 2.3 percent transmission, and it required a 50-nanosecond, 1.1-micro-joule pulse.

Optical Recording with Lasers

A study has been completed on the ablation of thin, partially-transmitting films of various materials on glass substrates. The purpose of the study was to investigate changes in the optical properties (reflection or transmission) of very small areas of the thin films when illuminated with high-energy density light from a focused laser beam. This is a method for recording information with a "write-head" that is not in contact with the storage medium, and in which no additional processing development is required before the information can be read out. Read-out can be achieved by various electro-optical schemes including use of DI-SCAN. The read-out can occur immediately (for checking purposes, for example), or at any later time.

Measurement of ablation in films of aluminum, gold, and carbon were made using a pulsed, and a Q-switched, ruby laser. For example, a 0.0016-inch hole was formed in an evaporated gold film of 6 percent transmission with a 30-nanosecond, 11.0

microjoule pulse; a 0.003-inch hole was formed in a smoked carbon film of 2.3 percent transmission with a 30-nanosecond, 1.1 microjoule pulse. On the basis of these measurements, calculations indicate that gallium-arsenide lasers should be capable of providing sufficient energy density at reasonable writing speeds to effect similar changes in transmission properties.

Photodetection with Semiconductors

In silicon, the ratio of electron mobility to hole mobility is close to one. In this project, various diffusion techniques were investigated to create trapping centers in silicon which would slow down one carrier preferentially. This is called mobility doping and it results in current gain when the material is illuminated to create electron-hole pairs, and a voltage is applied. A single-crystal, bulk-photoresistive, silicon device with built-in current gain (similar to the polycrystalline photo-detectors, but with a faster response time) is desired. Fabrication techniques for such a device are compatible with present-day, integrated-circuit techniques, and there are many applications for it in performance of computer memory, logic, and sensor input functions.

Silicon photoresistors were made by diffusion of metals known to introduce a double acceptor level into the forbidden energy gap. Some of the photoresistors had a current gain much greater than one. Calcium diffusion into silicon at 1000° C gave the following desirable results: current gain of 78 at room temperature, and 208 at liquid nitrogen temperature, with response time of approximately five microseconds. Other Group 2 metals such as cadmium, zinc, and beryllium have also produced mobility doping. Resistance-temperature measurements were made to study the energy of diffused impurity levels.

Gallium-arsenide diodes are used as light sources in the measurements of photosensitivity of the silicon devices. As part of this activity, and because of many other computer applications for these diodes, an evaluation program on the commercially available, light-source diodes was carried out.

PHOENIX GENERAL PURPOSE DIGITAL COMPUTER

Phoenix is a time-shared, multi-user, general-purpose digital computer designed, and being assembled by MITRE to become a facility in the Systems Design Laboratory. Phoenix consists of a central processor section and a peripheral unit processor, both of which communicate with a common system of memories. Both processing units can operate simultaneously as long as both do not need the same main memory unit.

The properties which make Phoenix suitable as a time-shared, multi-user computer are as follows:

Sufficient, random-access memory capacity to hold a supervisory program and one or more "user" programs.

Sufficient, medium-access storage (drum) to hold many "user" and support programs.

Ability to interchange data between the bulk storage and central memory at high data rates. Separation of input/output processing and processing of data in central memory.

An interrupt system which advises a supervisory program of input/output needs as well as "user" program needs.

Ability to relocate programs to various areas of central memory without requiring modifications of the programs.

Ability to protect areas of central memory to prevent interference between different "user" programs.

Ability to prevent "user" programs from directly affecting input/output operations.

Sufficient number of user input/output devices (such as typewriters) to permit many users to use the computer simultaneously.

DESCRIPTION

The central processor of Phoenix is a binary, single-address computer which performs at an average rate of 280,000 instructions per second. (It is capable of 500,000 instructions per second with faster memories.) It employs a 26-bit binary word consisting of a parity bit, 24 data bits, and

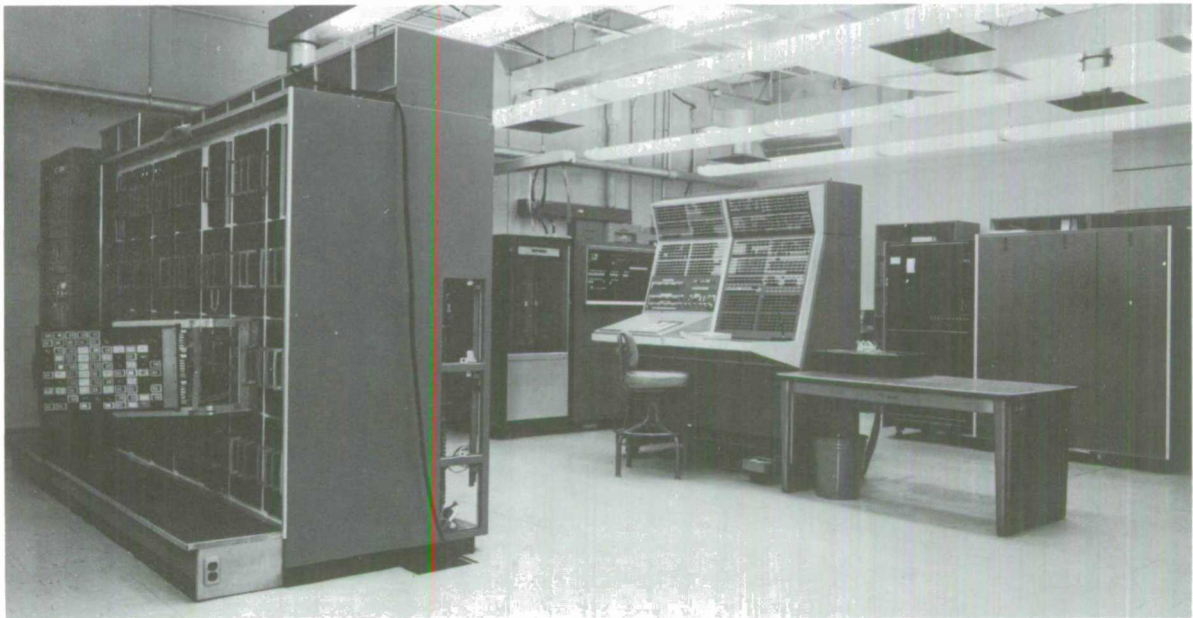

The Phoenix time-shared, multi-user, general-purpose digital computer is soon to become a facility in the Systems Design Laboratory.



This is a portion of the input/output area of the Phoenix computer. Sixteen Selectric typewriters are available for direct interaction with the machine.

a metabit. The metabit is used as a special control bit in portions of the central processor and the peripheral unit processor, and it can be stored in all random-access memories and the drum memory.

Minimum data are transferred directly between the central processor and the peripheral unit processor. The peripheral unit processor controls input/output data transfers between seven channels and the memory system. One channel is connected to a low-speed buffer system which, in turn, scans up to 32 devices and transfers data between them and its own 1024-word memory at the slow rate dictated by each device. Upon command from the peripheral unit processor, high-speed data transfers occur between the low-speed buffer memory and the central memory system. At the present time, 19 of the 32 devices are now connected. These include 16 IBM Selectric typewriters, one paper-tape reader, one paper-tape punch, and one digital incremental plotter.

The drum memory, the tape control unit, and the high-speed channel occupy three additional channels; there are three unused channels. The tape control unit can control up to eight magnetic-tape units or other devices with the same interface, such as an SDL-type display console. The high-speed channel can handle eight devices such as the DI-SCAN image-scanning device or a high-speed data link having a transfer rate of 250,000 characters per second.

DEVELOPMENT OF PHOENIX

Phoenix originated in 1961 with the transfer of the Air Force's Advanced Display Console (ADC), Reliability Test Assembly (RTA), and Transistorized Drum Assembly (TDA-1) from IBM to MITRE. These units were prototypes of the SAGE II display console and computer (AN/FSQ-32V). The aims or tasks to be fulfilled with this equipment were to permit evaluation studies in the areas of machine and human data processing, to provide a testbed for new,

high-speed circuit assemblies, and to provide a vehicle for evaluating machine organization and system designs.

The Reliability Test Assembly was a good beginning with which to accomplish these tasks. It had been constructed of very advanced circuits which allow Phoenix to compare favorably with the new computing systems of 1964. However, RTA was a "test assembly" and not a full-sized system; several additions and modifications were made by IBM in accordance with specifications prepared by MITRE to adapt it to its new task.

Inasmuch as no magnetic-tape hardware was functioning on RTA, a specification was prepared at MITRE for a magnetic-tape control unit. Specifications were also written to increase the capacity of the drum (TDA-1) from 40,960 words of 24 bits each using five drum fields, to 278,528 words of 26 bits each using all 34 available drum fields. The principal, random-access memory on RTA had consisted of a 1024-word core memory with a 21-bit word and a two-microsecond cycle time. This capacity was much too small to allow the computer to perform its new task. With slight modification, this small memory could be made an essential part of a new data buffering system (the low speed buffer) which would handle the lower-speed, input/output devices such as typewriters and paper-tape equipment. For this use, specifications were prepared to increase the word length of the memory to 26 bits and reduce the cycle time to 1.8 microseconds. These modifications of the drum and 1024-word memory and the new construction of a tape control unit were completed by IBM in 1962.

In 1962, the tasks for which Phoenix was intended were enlarged. The machine was to become a newer form of general-purpose computer to supplement and complement the IBM 7030 facility for command and control system experiments, and to provide a vehicle for testing new machine designs. Phoenix emerged as a time-shared, multi-user computer. The size of Phoenix was limited to that which could be built from the

hardware available in the main frame of RTA and a supply of similar hardware declared surplus by the AN/FSQ-31V SAC computer program. The computer was defined implicitly by an initial programmer's guide, "Reference Manual for the Phoenix Computer."

All RTA main-frame wiring including the direct current power system was abandoned. The following system elements were completely redesigned by MITRE: power system, memory control, control processor; peripheral unit processor; the low-speed buffer to handle the increased number of low-speed devices; a modified, tape-control unit to handle new, faster tape-drives and allow for special, high-speed inputs; and a new maintenance console. The RTA main-frame was increased from its former, six logic modules to seven logic modules, and the power module was replaced with a larger one. By September 1964, all of these modifications on the system elements had been completed by MITRE.

Changes in the 1024-word, low-speed buffer memory have been made which allow this memory to serve temporarily as main memory in order to perform further system tests. Delivery of two, 16,192-word memories is expected in March 1965, and a complete computer system is anticipated in May 1965.

DESIGN MECHANIZATION

The central processor, peripheral unit processor, and low speed buffer are contained in the main frame of Phoenix in 94 drawers; there are 18 spare drawers in the frame at present. Each drawer can hold 100 Q-pacs which are the basic, logic-circuit, building blocks.

Approximately 250,000 wire-wrap connections or nodes were specified and connected to produce the computer. The manpower, tedium, and numerous clerical errors normally associated with the conventional method of accomplishing such a major task were substantially reduced through the development and use of a design mechanization technique which employed an IBM 7090 computer. The conventional method starts with logic

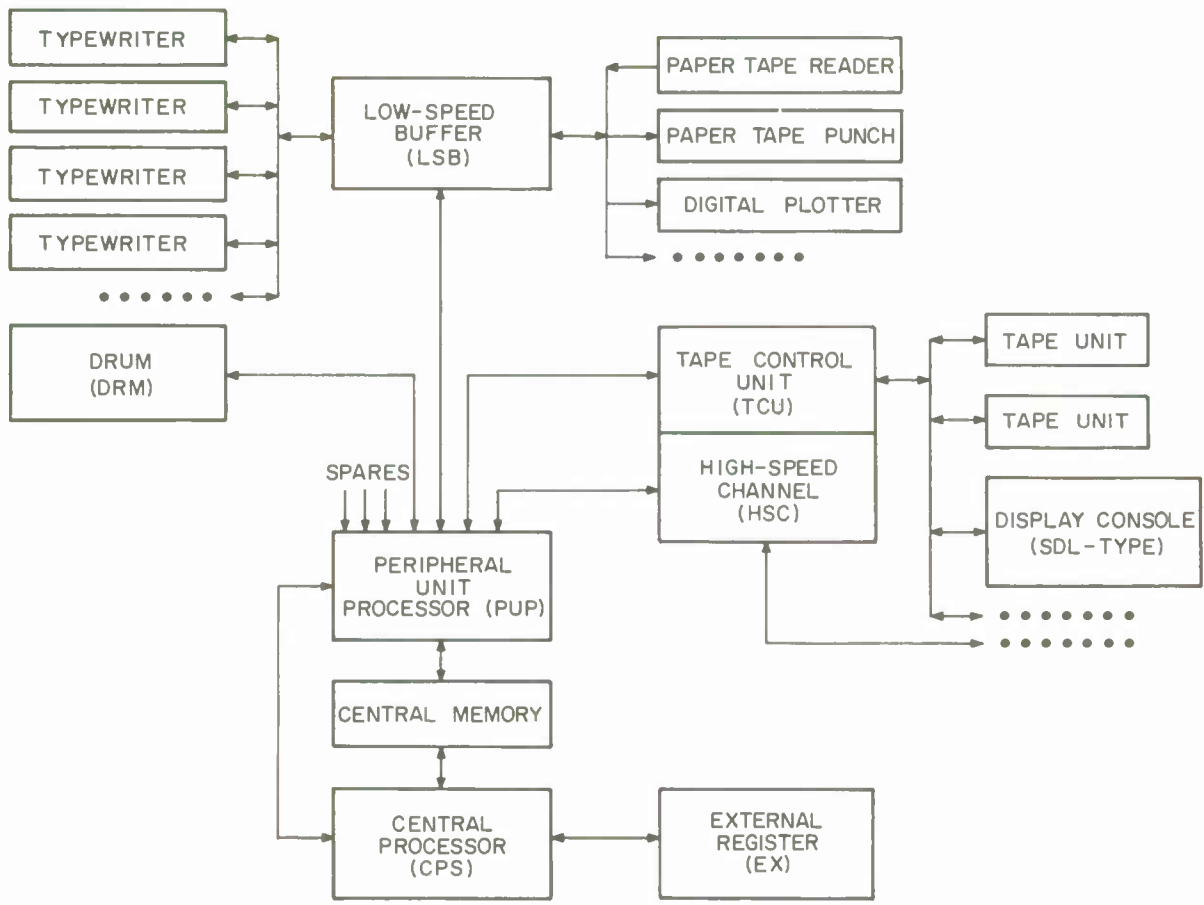

Phoenix computer block diagram.

drawings on which symbols are used to represent each basic logic circuit. These symbols are drawn and joined by the designer to indicate the desired interconnection according to the sets of logic equations. From these drawings, data suitable for wiring the computer are copied and listed by hand by a number of clerks. Consequentially, many errors of specification occur throughout this process.

In the mechanized technique used, the designer represents his general logic expressions in separate logic equations, one for each logic circuit (such as an AND, OR, or FLIP-FLOP). A unique, eight-character name is given to the output of each circuit; this name is used thereafter at the inputs of other circuits, where required. The type of circuit employed and its location are also given by the designer. These equations are prepared on punched cards so that they may be processed by a series of IBM 7090 computer programs which perform the following clerical operations:

Assign socket pin numbers and load/terminating resistor values.

Check for wiring rule violations.

Print lists of the logic equations for use by the designer and checkout personnel.

Prepare and print wire lists from which the machine is constructed.

Only one clerk was needed for the entire computer reconstruction. There were no errors of specification and approximately one error in every thousand electrical connections.

The computer programs enable corrections to be made to the lists and selected portions of the equation or wiring lists to be printed. Debugging of the machine was facilitated by the legible and concise listings.

DOCUMENTATION

Berkowitz, D. A. and Schippert, M. "Hall Effect" *B-H Loop for Thin Magnetic Films*, TM-3716, The MITRE Corp., September 1963 (Unclassified).

Berkowitz, D. A. and Tammaru, E. "Collection Efficiency of Receivers Placed Close to Sources," *J. Opt. Soc. Am.*, 53, 1963.

Computer and Display Department Staff, *Reference Manual for the Phoenix Computer*, TM-3870, The MITRE Corp., November 1963 (Unclassified).

Cho, Y. and Zimbel, N. "UNIVER: A Fast, Versatile, Multilogic Digital Amplifier for Micrologic Circuits," *Proc. IEEE*, 52, 1964; see also ESD-TDR-64-136, December 1964 (Unclassified).

Everett, P. N. *Lead Attachment and Encapsulation Techniques for Thin Film Microcircuits*, ESD-TDR-64-635, in press (Unclassified).

Liu, J. W. S. *A General Method to Compute the Characteristics of Microstrip Transmission Lines*, ESD-TDR-63-238, August 1963 (Unclassified).

Liu, J. W. S. and Zimbel, N. S. *Fast Logic Circuit Test Assembly*, ESD-TDR-64-637, in press (Unclassified).

Neilsen, R. S. and Ford, M. A. "DI-SCAN: A Versatile Image Sensor," *Proc. Sym. Opt. and Electro-Opt. Information Processing Tech.*, The Technology Press, Cambridge, Mass., in press (Unclassified).

Schippert, M. "Hall Effect" *Hysteresis Graph*, ESD-TDR-63-436, October 1963 (Unclassified)

Tammaru, E. "Using an Analog Computer to Analyze Transistor Circuit Performance," *Solid State Design*, 28, October 1964.

Tveitan, W. *Characteristics of a Helix with Outer and Inner Coaxial Shields*, Master's Thesis; MIT, Dept. of Elec. Eng., January 1964 (Unclassified).

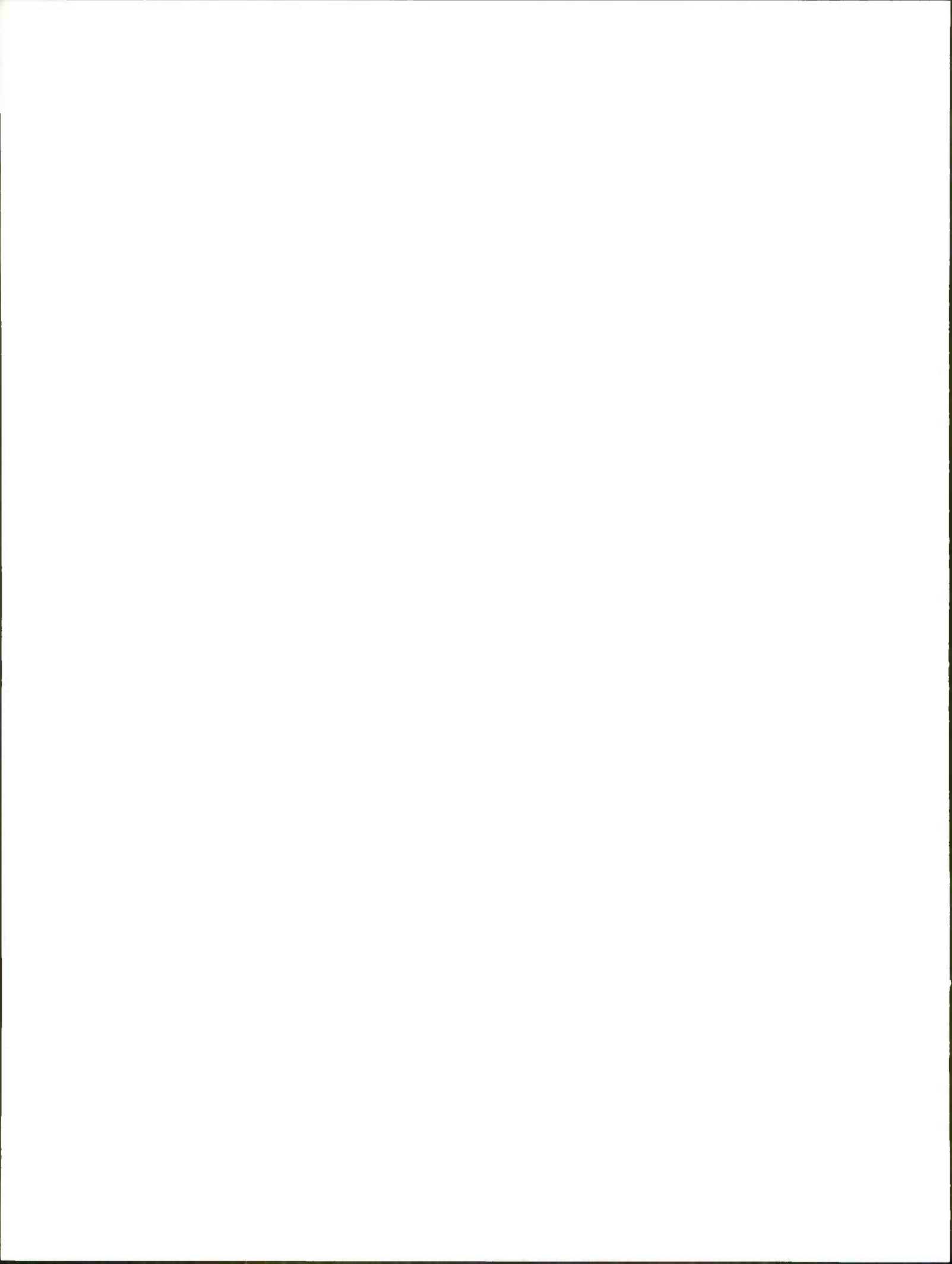

VI SYSTEMS DESIGN LABORATORY

The need for a test environment for the real-time simulation and design evaluation of electronic information systems was established by the Winter Study Group, sponsored by the United States Air Force in 1960. The group, which consisted of scientific, industrial, and military participants was set up to study problem areas in the development of large information systems. One of the recommendations of the Winter Study Group was that a single facility for design verification of the various computer-based command and control systems be established in order to strengthen the technological base for the systems concepts during the initial period of their development.

The Systems Design Laboratory was conceived in response to this recommendation. L. G. Hanscom Field was chosen by the Electronic Systems Division Headquarters as the most suitable location. A laboratory building was constructed to house the facility, and it was dedicated in December, 1963.

Within the Systems Design Laboratory are placed all the necessary, modern computational tools, display facilities, and other input-output equipment required for system design and study. This chapter describes the equipment, the major computing systems in which it is grouped, the basic function and use of each item, and the facility programming required to secure the most efficient use of its capability.

HARDWARE

The main computer facility in the Systems Design Laboratory is an IBM 7030 (STRETCH) computer with its various support and peripheral equipments. In addition, there is an IBM 1410 computer, and an Electronic Associates PACE Analog Computer. The Phoenix multi-user, general purpose computer, described elsewhere in this report, will also become a facility in the Systems Design Laboratory.

The Command Post equipment is considered part of the support for the 7030. It includes four display consoles which are described in de-



Systems Design Laboratory in which various computer-based command and control system designs are simulated for the purposes of research and design verification.

tail because their design, specification, and acquisition represent a significant technical activity at MITRE.

7030 (STRETCH) COMPUTER

The IBM 7030 is a transistorized binary machine with a word length of 72 bits (64 information bits, 8 check bits) and a memory access time of 2.18 microseconds. The effective time of executing instructions may be less than 2.18 microseconds. Since the core memory is dual, it can be operated with interleaved access. There is instruction look-ahead, and a memory word can contain two instructions.

There is a 65,000 word core memory, and a 2-million word high-speed magnetic disc file on the Central Processor Unit. There are sixteen input-output channels, to which are connected the operator's console, card reader, card punch, printer, twelve tape drive units divided among

three tape channels, a modified IBM tape adapter which drives the four SDL display consoles, and two high-speed communication line adapters that connect either to two telephone data sets, or to one data set and four printers.

The display consoles located in the Command Post are complemented by an Eidophor projection wall display. The Eidophor display is a 945-line, closed circuit TV system that has no electrical connection with the 7030 computer. Normally, a video camera is used to pick up the image from a cathode ray tube display, but film and other image media are equally suitable for projection in this manner.

The support equipment includes four card punches, two verifiers, one interpreter, one sorter, one collator, one reproducing punch, one IBM 1460 computer, and a plotter. The 1460 computer has a 12,000-character core memory (8 bits per character position), a 2-million character disc file, three tape drives, two high-speed printers, and

one card read/punch. The 1460 computer is used to process the output tapes from the 7030.

The plotter is a Benson Lehner ElectropLOTter Model J. Input to the plotter is usually in the form of binary-coded decimal data recorded on tape, such as that which may be produced in a 7030 run. The plotter will accept up to four significant digits in X and in Y. Scales can be selected by the input data, and alphanumeric characters can be printed on the plots. The plotter can interpolate between data points for line drawing.

1410 FACILITY

The IBM 1410 computer is a transistorized, variable-word-length, character-processing computer. The core memory capacity is 40,000 characters. Each character position corresponds to eight bits: six bits for a character, one parity bit, and one word mark bit. The average memory access time is 4.5 microseconds per character. The two input/output channels can be used while computing. On one channel are five disc files with a total capacity of ten million characters. On the other channel are five tape drives and a display console with a typewriter, and a high-speed printer and card read/punch.



General view of the computer area on the lower level of the Systems Design Laboratory containing most of the components of the IBM 7030 computer.

The 1410 computer has been used to prepare 7030 computer input tapes from punched cards, and is being used in program language studies.

ANALOG COMPUTER

The PACE computer is a transistorized, analog machine. Its advantages are ease of programming and program modification plus rapid visual observation of problem solutions with its variety of output devices. These include two multichannel recorders, three X-Y plotters, and a 21-inch oscilloscope.

The analog computer is frequently used for the study of physical and electronic systems whose behavior is described by a set of mathematical equations; frequently by linear or non-linear differential equations. Dynamic response functions can be observed and recorded, and events can be simulated on either a dilated or a compressed time scale.

SDL DISPLAY CONSOLES

The Systems Design Laboratory display consoles were built by Data Display, Inc., to MITRE specification. Six of these consoles have been installed as part of the SDL. The consoles accept digital data from an associated computer (usually the 7030), store it in a 2048-word core memory, and interpret it as commands to present various symbols at specified locations on a cathode ray tube. These displays can show alphanumeric and special symbols, vectors, points, and graphical displays derived from 35-mm film. Display rates and data transfer rates are very fast; display quality (brightness, contrast, and legibility) is excellent. Associated with each display are several means for the display operator to enter messages, via the display memory, into the computer. These are a light pencil, a typewriter, and a set of push-button switches. Many features of the SDL display consoles were unique when the specification was written and have since influenced the development of later displays. Some of these features are discussed below.

Logical Design

The logical design of these displays was specified by MITRE. The display coding is highly



A command post at the Systems Design Laboratory provides complete facilities for the simulation of command system operation. The display consoles and typewriters are connected to the IBM 7030 computer. The wall screen, on which closed-circuit projected television can be displayed, is easily viewed over the low profile consoles.

efficient in that the quantity of data required to specify a given display is minimized. The coding also permits flexible manipulation of the displays. Both the classification of display data into various categories and the assignment of memory space to each category are entirely under computer program control. Many display functions which are commonly built into the display hardware are controlled by the computer program in the SDL system to provide the flexibility in the use of the consoles which is so essential to meet the constantly changing requirements of an experimental facility. Modifications of this logical design have since been adopted by at least two other military display systems.

Computer Interface

Each SDL display console is connected to an associated computer through an interface which is identical to that normally used to control a magnetic tape drive. Since practically all computers use magnetic tape drives, this provision makes it easy to connect the display to any one of a large variety of computers. The SDL consoles have been connected to 7030, 1401, 1460, and 1410 computers with little difficulty. The data transfer

rate is normally 62,500 6-bit characters per second but can readily be adapted to different speeds. One console has been adapted for connection to a 2000 bit-per-second telephone line interface.

Since the SDL display specification was released, a number of other display systems have been announced with magnetic-tape drive interfaces. The flexibility provided by this design feature is now generally recognized.

Programmable Characters

To obtain a wide variety of different, special characters for display, some of the display characters are controlled by codes contained within a reserved part of the display memory. By this method, the necessity, common in other systems, of interchanging insertable cards has been avoided. Changing circuit cards in order to change symbols is a satisfactory method of changing the character set of a display provided that the requirements on that display are relatively static; if there are frequent changes in display usage, requiring frequent changes in the character set, then there is some difficulty in keeping track of the symbols available at any one time.

Therefore, 18 of the 63 symbols in the SDL display character set are programmable, and the appearance of the characters at any one time is dependent upon the computer program at that time. Each display operator can have available to him the symbols he needs, and there is no problem of interference with other display users.

One reason that this innovation has not yet been commonly adopted in the industry is that the degree to which character requirements change from job to job is not always recognized.

Graphic Display

Displays of the general nature of those in SDL provide for the generation of symbols and usually of vectors. But, when the display of a map background or a tabular chart form is required, the use of the computer program to generate this relatively fixed display, and the use of computer and display memory to store the picture, are often inconvenient. In order to economize on computer

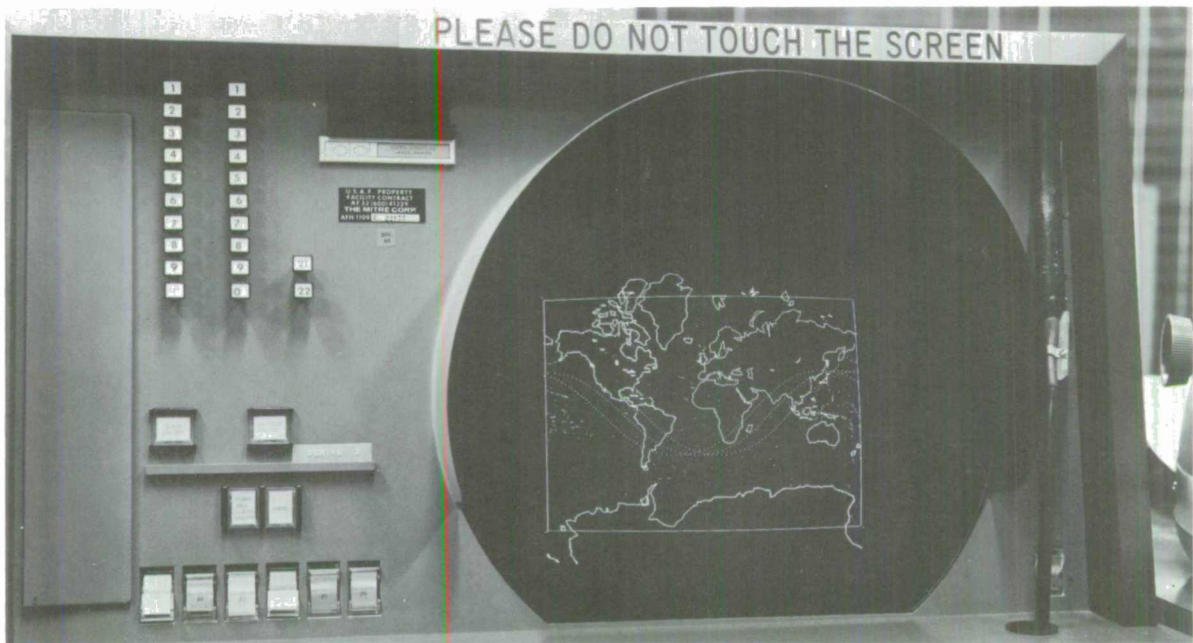

The map displayed on the surface of the display console cathode ray tube is a Mercator projection of the earth on which is traced the successive paths of a satellite. The information is stored in the core memory of the console and is presented without flicker. The light gun and the inquiry and category switches permit the operator to modify and augment the display and the information in the main computer.

programming and memory requirements, the SDL displays include a graphic display system which uses a flying spot scanner to transfer an image from a 35-mm film strip to the CRT face. Any one of up to 64 images may be presented by this means, and the face of the CRT is time-shared between this image and the image generated from digital data provided by the computer. The computer is able to select the frame to be shown, and the film strips may be changed quickly and easily.

Inquiry Generation

The SDL display console has the most complete set of inquiry generation facilities available. This is partly because it is designed for use in an experimental facility. The inquiry facilities include a typewriter, a set of inquiry switches, and a light pencil.

A modified IBM Selectric typewriter has been designed to allow the operator to insert messages for the computer into the display memory. The typewriter can also be operated from the computer through the display logic, thus permitting permanent copies of alphanumeric data to be printed. Two special type elements for the typewriter were designed to provide a character set specifically useful for the types of data manipulation for which the SDL is designed.

A set of 22 inquiry switches is provided which may be used by the display operator to code special messages to the computer with a minimum of effort and error. In keeping with the emphasis on flexibility in the use of the display, the interpretation of these switch-encoded messages is determined by the computer program so that the same small set of switches is usable for many dif-

ferent operations. This method of organizing switch inputs to a computer is much simpler and less subject to error than the method often used of providing the display operator with literally hundreds of switches each having a unique meaning. Program definition of switch inputs has been used by at least two manufacturers in the last two years.

The SDL light pencil allows the display operator to identify to the computer program a particular displayed item by providing the program with the memory location of the code specifying it. (This form of identification is generally easier to use than the identification which provides only position data for the item, and makes the computer program correlate position with code.) There are some problems, however, which will more conveniently use position information in their solution. The SDL display console was designed to provide data identifying the position of the light pencil on the display surface as well as, or instead of, data identifying the memory location of a particular symbol.

Implosion Shield—Anti-Reflectant Design

All CRT displays require an implosion shield in front of the CRT to protect the operator. Unfortunately, these implosion shields, and the CRT face itself, usually reflect, specularly, objects in the display room.

Anti-reflectant treatment to minimize specular reflection is a significant improvement, and it can be expected to be used more frequently in future. It is only with careful treatment such as this, and with careful lighting design, that CRT displays can be effective in bright ambient lighting such as is desirable for detailed visual tasks extending over many hours.

SOFTWARE

Facility programming at the Systems Design Laboratory enables users of the 7030 computer to write and run their programs with a minimum of difficulty. Detailed technical requirements are not excessive, and the computing environment is efficiently organized. An adequate body of pro-

gramming languages, libraries of generally useful subroutines, and effective supervisory software are continuously developed and maintained.

Corresponding to the broad distinction between those who write computer instructions for problem solution, and those who describe problem solutions, two basic languages for the 7030 are available. STRAP is a machine-language assembler in which the programmer can specify full detail and obtain optimum performance; its vocabulary and syntax are intricate and require special study. For programs that do not require the capability of STRAP, a FORTRAN IV compiler is available. By eliminating intermediate phases and reworking input-output, the FORTRAN compilation has been made as fast as the STRAP. The different advantages of the two languages can be combined through a feature of the software which permits mixtures of FORTRAN and STRAP-coded routines within a job, through linkages provided by the Binary Symbolic Subroutine loader (BSS).

SMAC, a powerful adjunct to STRAP, is a language processor which translates macro-instructions using routines available from the system library or supplied by the programmer, into a STRAP program. SMAC enables the qualified user to specify—and, if he wishes, to write—compiling procedures for his own or related programs within the assembly process, and thus offers a capability of almost unlimited variety.

Two additional languages developed for particular applications are SIMTRAN and FAST. SIMTRAN compiles programs written in SIMSCRIPT, a language designed to facilitate the programming of complex simulation problems. FAST is an expanded FORTRAN, particularly useful for data-processing in which the definition of data categories can be read from a common dictionary external to the programs which call for it. FAST permits convenient modification of parameters shared among various programs, and through special built-in functions, it permits a flexible handling of data of different structure.

Subroutines available for general use include a set of mathematical and logical subroutines and an input-output control subroutine (IOCS). To-

gether, they compose a library for use in FORTRAN programming. Routines for SMAC corresponding to commonly used techniques in macro-analysis are also available. Facility programming provides access to this code automatically or, where modifications are desired, by input from specified external sources. Considerable additional subroutine material pertaining to input-output and other utility functions is incorporated in the monitor routine called Master Control Program (MCP).

The MCP also supplies an environment for job processing designed to optimize 7030 operations. It handles system and program input-output in such a manner as to avoid equipment conflicts wherever possible by proper scheduling, handles all operator instructions, sets up and executes compilations, monitors interrupts to interpret error conditions or convey information to the operating program, and provides accounting information as required. Although designed to process jobs sequentially, it is undergoing modifications to permit two or more programs to operate simultaneously. Programs which do not require continuous use of the central computer will relinquish control when possible (for example, while awaiting action from viewers of a display). Since time-sharing offers the possibility of radically improved computer access, its further development is currently under investigation.

Facility programming other than that directly for the 7030 has resulted in the development of input and output processors to run on the 1460, together with a number of support programs which perform functions such as standard card and tape processing and the updating of data files sorted on tape. A group of 1460-oriented programs such as the Autocoder assembler are maintained as part of this development effort.

The 1410 computer has its own operating system containing a supervisory monitor, compilers for Autocoder, FORTRAN, and COBOL, and a linkage loader which provides an environment analogous to that of BSS on the 7030. Facility programming has supplemented this software package with input-output utility routines where these have been needed.

DOCUMENTATION

Mechlin, R. N. *System Design Laboratory Utilization Plan for Fiscal 1965*, TM-4092, The MITRE Corp., in press (Unclassified).

Mitchell, J. *An Input/Output Typewriter for Communicating with a Digital Computer*, ESD-TDR-64-81, March 1964 (Unclassified).

Mitchell, J. *Description of the System Design Laboratory Display Consoles*, ESD-TDR-64-150, in press (Unclassified).

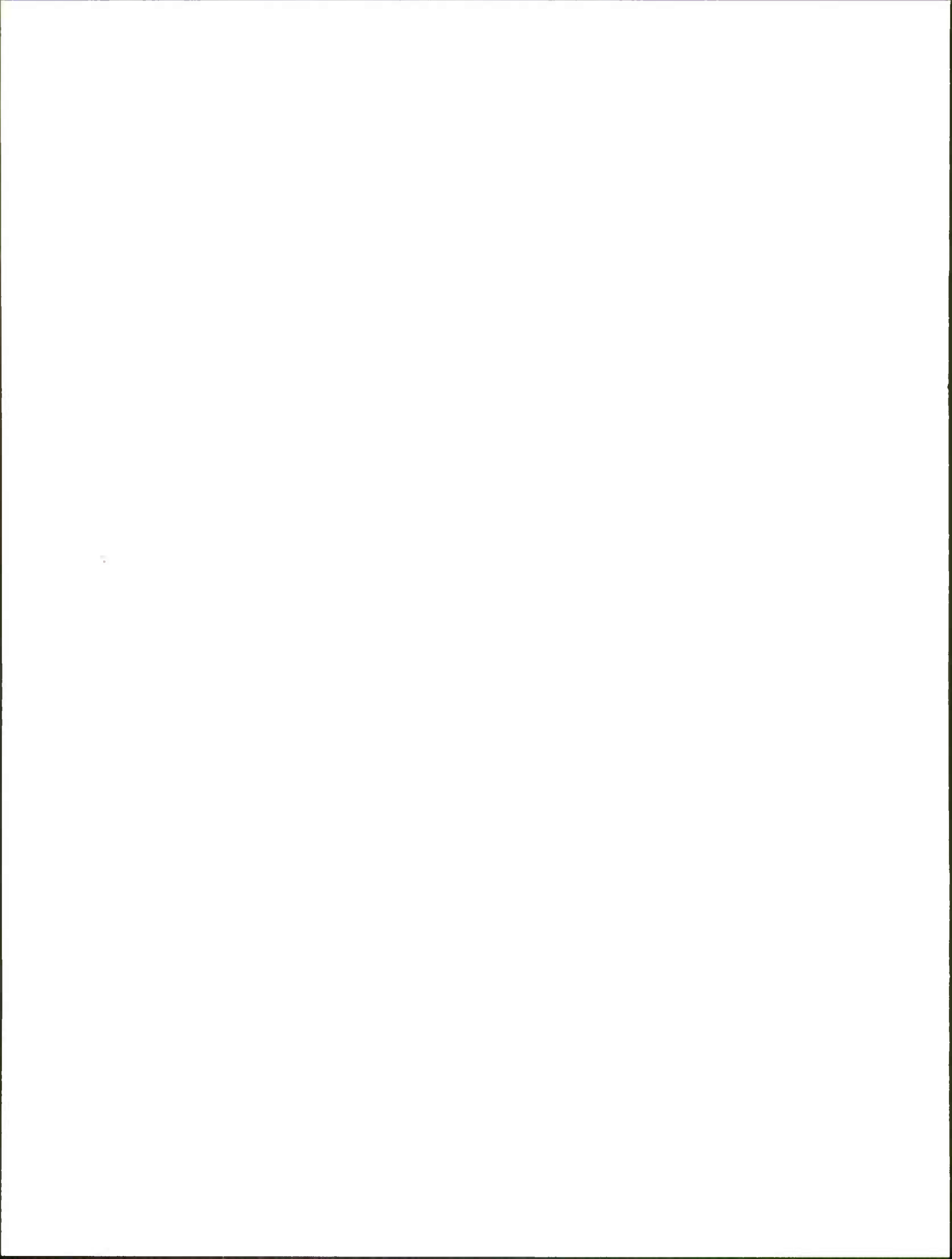

VII INFORMATION PROCESSING TECHNIQUES

The MITRE Information Processing Techniques program investigates, develops, and evaluates advanced techniques for the utilization of digital computers both as integral parts of command and control systems and as tools for the system design and evaluation process. Significant contributions have been made to the Corporation's capability for assisting the Air Force in the design and acquisition of computer-based information systems, while materially advancing the state-of-the-art of such systems as well.

In fulfilling its objectives, the program has been concerned with Data Management Systems, Processing Techniques, and Retrieval Systems.

DATA MANAGEMENT SYSTEMS

The increasing emphasis upon quick, flexible military response in terms of force deployment, resource allocation, and timely intelligence estimates has upgraded the value of the computer as a useful and powerful command-system tool. The efficient utilization of such a tool by a commander

and his staff demands more flexibility and better means to control the operation of the computer program than was required in earlier systems intended more for control than for command. Moreover, unlike the operator in a typical control system, the commander will not have had elaborate training in the operation of automatic data processing equipment. Consequently, it is necessary that his data management system employ a "command language" in which the vocabulary is the normal specific vocabulary of the using command.

To provide command data management systems with these necessary qualities of flexibility and ease of employment, system designers have been increasingly turning to software technology. The MITRE Data Management Systems project is consequently heavily software-oriented and is concerned more with finding better ways to use existing hardware than in developing new computers. Software and hardware cannot be completely divorced, however, and close working relations are maintained between this program and

such hardware-oriented ones as the "Phoenix" project, described elsewhere in this report. In fact, one portion of the Data Management System activity ("Time Sharing System" work) has, as one of its primary goals, the development of software for the Phoenix computer.

A data management system of the sort described here must be capable of:

Querying

Message Processing

Preparing Reports

Displaying Information

Routing Information

Format Control

Updating (creating new files, adding additional data, either per element or by adding new elements to the file, and creating subfiles out of the file.)

The activities have been directed toward developing methods whereby users (who may not be computer specialists) could flexibly control and direct the performance of the preceding functions and obtain easy on-line access to the data files.

The current program is a logical outgrowth of the work performed by MITRE in developing the Experimental Transport Facility (ETF) for the 473L (Headquarters USAF Command and Control) System. The programs for this facility incorporated file generation and retrieval capabilities of great generality and were based upon the concept of the "self-described file." The facility also included a near-English query language.

Two new programming systems, COLINGO and ADAM, evolved from the generalized approach pioneered in the earlier project. COLINGO (*Compile On-Line and GO*) is oriented to the light-computation, large-file-handling, information retrieval class of problem, with heavy emphasis on the user interface in all phases of systems operation in the field. ADAM (*Advanced Data Management*), on the other hand, is aimed at the system designer. It has a large computing capacity, is capable of rapid and complete system



reconfiguration, can support multi-user interaction in problem solving, and permits the user to control his formats and languages.

Another important area of work in the Data Management Systems program is concerned with developing the basic set of programs required for the MITRE Phoenix Computer System. This computer is designed to facilitate time-shared operation for on-line users. Included in the basic program set are four main elements: Supervisor or Executive System, Translator, Debugging Program, and Editing Program.

EXPERIMENTAL TRANSPORT FACILITY

The design of the Experimental Transport Facility was conceived to assist MITRE in generating solutions to some of the problems of the 473L System. In this connection, the Military Air Transport Service (MATS) transportation-planning function was selected as a manageable, educational, and relevant task.

The MITRE effort resulted in a set of programs written for the AN/FSQ-7, XD-1 SAGE prototype computer, another set for the IBM 7090 computer, and certain hardware. The hardware included an adapted SAGE console, with provisions for front-projected background map overlays for geographic information displays, a Teletype automatic send/receive unit for query inputs, and a Burroughs Whippet high-speed printer for tabular outputs. The system incor-

porated a general retrieval capability for a MATS planning data base along with a transport planning program. Queries from the data base and specifications for plans were handled via a near-English query language.

At the time the system was begun (1961), MITRE was in the process of collecting data for the base and was uncertain as to the final contents and format of that base. However, to initiate system design and programming, general programs for data base generation and retrieval of information from such a data base were produced.

Based on machine availability, the programs for generating data bases were written for the IBM 7090 computer, and all other programs were written for the XD-1 computer.

The initial system, including file generation on the IBM 7090 and on-line querying on the XD-1, was running in January 1962, and the 473L experiments by March 1962.

About this time, the 481L (Post Attack Command and Control System) project office became interested in using the same query facility to perform experiments in aircraft recovery. A data base was collected, some improvements were made in the system programming, and the 481L experiments were running in June 1962.

Data Base Structure

The general concept of the ETF systems was that the data base, regardless of the type of information it contained, could be operated upon and used for retrieval by the XD-1 programs. As a result, the data bases were self-described, which means that object, property, and subproperty names were contained in dictionaries generated by the IBM 7090, and made a physical part of the data base. These dictionaries were used, in conjunction with the data, for retrieval by the XD-1 programs.

A data base is subdivided into files. If an airfield file is desired, such a file is subsetted by objects which are airfields. Each object in the file is described in terms of properties or attributes such as latitude, longitude, state, and

country. The system was later expanded to include one level of subproperties. In the case of an airfield file, if an object has multiple runways, WIDTH and LENGTH are subproperties of the property RUNWAY. The system allows for different numbers of runways at different airfields.

Data Retrieval

Information was retrieved from the data bases by typing queries in a form resembling English on an input teletypewriter. Replies were received on a teletypewriter (the same one or a different one), or on high-speed Whippet printers.

A simple query might be: GET AIRFIELD IF RLEN GR 10000 LIST LAT LONG RLEN CTRY. The query asks for a list of airfields with runway lengths greater than 10,000 feet. For each such qualifying object, the properties latitude, longitude, runway length, and country are to be listed below.

Two types of calculational abilities were also available as a part of the query language. The word DIST was used to ask for the great circle distances between such things as cities and airfields. The word COMP allowed the user to specify an equation to be evaluated.

One additional capability was that of string substitution, which enabled the user to store a string of characters in the system and assign a name or tag to them. These strings were defined on-line with a typewriter or by means of punched cards. The user referred to the string in his query by means of the tags.

The generality of the file generation and data retrieval portions of this system was proved by using these portions with the PACCS data base and an engine file; this was of interest to the Air Force Logistics Command.

Application-Oriented Programs

In addition to the general query capabilities, the final ETF system also included three separate sets of application-oriented programs: Operate Gross, to calculate airlift requirements; Base Support, to determine support requirements at airfields; and the Deployment Calculator, to de-

termine mid-air refueling requirements for fighter aircraft.

COLINGO

The COLINGO System is a command-language system which has been provided to the U. S. Strike Command (USSTRICOM) in support of an interim command-and-control system. In essence, it is a general purpose, user-oriented information system which is modular and evolutionary. The system is completely controlled on-line by the user. COLINGO embodies four basic design concepts:

It is easily maintainable by the user with a limited number of in-house personnel.

It is capable of satisfying changing and unpredictable operational requirements, subject to the availability of pertinent data.

It possesses growth potential, with additional features and capability incorporable by personnel from the user organization.

It provides a general operational capability, even in areas in which no specialized capability has yet been programmed.

The fundamental purpose is to rapidly provide the user with information required to make operational decisions. No decisions are made by the system itself, but only by command personnel. The system, in fact, serves as a tool to retrieve data in prescribed combinations and to assist in the development of computational results which help to narrow the range of alternatives open to the decision-maker.

The data on which the COLINGO system is based varies widely in type, but generally will be structured in files according to a uniform set of formatting rules, which tell where the data is stored and how it is identified. Consequently, the procedures and computer programs used to retrieve the data, and to process it, can be made applicable to any data formatted according to the rules, regardless of data content. Moreover, new files can be introduced into the computer, and files in the computer can be changed or deleted with a minimum impact on the total computer

program, and with no change to the retrieval programs. Such a system is "data-independent."

In terms of the user, the implications of data independence are a reduction in the cost of maintaining the system, and a resultant decrease in the degree of system obsolescence.

COLINGO essentially consists of a basic program set which allows the user to store, retrieve, and manipulate data at electronic speeds with a minimum of difficulty. This basic set of programs may be readily expanded by the user in conformity with certain existing rules. The system functions in an IBM 1401 or 1410 computer which has a limited core memory. The sequence of COLINGO program operation is governed by one basic program known as the EXECUTIVE routine, which remains in core at all times.

All queries are processed under control of the EXECUTIVE, which in turn calls in the routines necessary to translate and operate system queries. One program at a time is called in to perform a given task, and therefore the program is termed "interpretive," i.e., it executes operations as they are encountered in the query rather than compiling an object program.

The disk is the usual storage medium (although tape can be used, with degraded response) from which a program can be called to the action station in core. The EXECUTIVE routine determines which routines are to be read in and operated by means of "action verbs" which it finds while scanning the message. The para-



meters following the referenced action verb describe for the "action program" the instructions for performing specific actions on the incoming data records. As the data is operated on, intermediate results may be stored on a system scratch tape which serves as auxiliary storage. The output of the final computations is printed, punched, or typed in a user-determined format on a specified output device.

From the user point of view, COLINGO is operated and controlled through the COLINGO Control Language (CCL). This consists of a series of commands or verbs which allow the user to generate a data base, record its description in system "dictionaries," operate on it, and produce an output in accordance with a specified format.

The system may be controlled entirely through on-line operation, including the addition of information to the data base. Lengthy additions of data or programs to the system, however, would normally be done in an off-line manner through punched card or magnetic tape input.

The COLINGO Control Language is a simplified language which, though limited in its forms, is both powerful enough to meet the needs of the user, and close enough to English to be natural and easily learned. The operator of the system must know the contents of the data base and the names of the properties contained in the files; selection and retrieval of information is then a simple matter.

The CCL has a grammar, punctuation, and syntax which must be strictly adhered to in phrasing a message. The vocabulary is, however, to a great extent created by the user to fit his particular needs. This ability, along with English grammar and punctuation, provides a language capability applicable to a wide variety of applications.

The basic design concept of COLINGO can be summarized as providing as much on-line control of the operation of the system as possible, and in a form which matches the user's and oper-

ator's needs and capabilities as closely as possible. Sophisticated internal data manipulation, language processing, etc. are sacrificed in favor of an easily managed and understood data base and a single language which is as powerful as necessary, and as natural as possible within the capabilities of the computer. An easily mastered on-line capability to enter, retrieve, present, update, and process data, using near-English input statements, is the essence of COLINGO.

A newer version of the COLINGO System is currently under development for the IBM 1410 computer at USSTRICOM. The design concept embodies an interpretive language for producing the COLINGO System itself, thus enabling easy transmutation to another machine. In addition, operational capability will be increased by including multiple file operations, a more flexible language and syntax, and a string substitution capability. In addition, file structure will be significantly more advanced than that presently available in COLINGO, to allow for complex inter-relationships among data groups.

ADAM

ADAM is a computer program system being built for the Systems Design Laboratory as a tool for use in the design and evaluation of military information systems. It will also be used as a test-bed for new techniques in information processing and, in addition, should provide information concerning the applicability of similar computer systems in field use (as opposed to the laboratory).

The need for a tool like ADAM was suggested by MITRE's experience in the design of command and control systems. SAGE showed that the lead time required to incorporate design changes into the system was excessive as a result of both the extensive work required to validate proposed design changes in a suitable simulation and the difficulty of changing the operational system itself. The process for producing a suitable simulation was a lengthy one because of the costly and time-consuming difficulties of building or

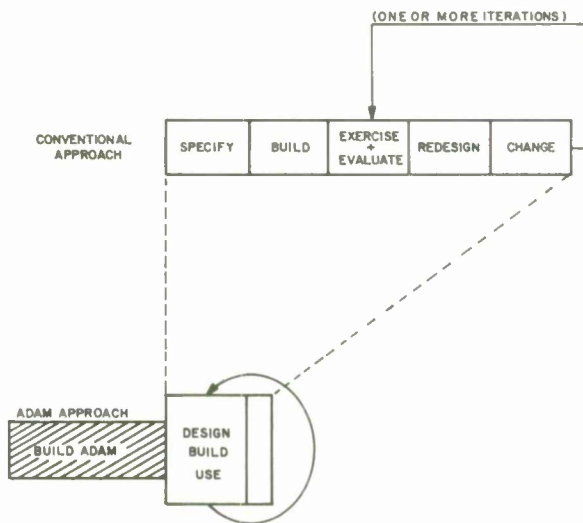

Through the use of ADAM, the system design process is shortened.

changing large computer programs. The cost is even more evident when it is realized that many passes through the EXERCISE/EVALUATE/REDESIGN/CHANGE cycle may be required before an adequate design is attained. This applies to building systems as well as building simulations because military systems, by their nature, are subject to continuing evaluation and improvement.

Naturally, a method of reducing the exorbitant cost of the conventional approach to system design and design verification tasks was desired. When ETF proved successful at handling two divergent problems (the second of which was not even contemplated when the program was designed), the present approach, which grows logically out of the ETF work, was undertaken.

With the ADAM approach, the design cycle can be shortened immensely; since the important building blocks are already there, the designer modifies the system to suit his purpose by changing his data but does not need to make extensive programming changes. System functions most likely to be required in a real-time multi-user, on-line data handling environment are generalized.

The general system functions built into ADAM include: admission of new data (in various user-specified formats) into the system in an organized manner, and the maintenance or updating of data previously accepted; translation and processing of requests (in various user-specified languages), to manipulate the data base, generate reports, etc.; and presentation of the desired output to the requested output devices in user-specified formats. ADAM provides a method for specifying operations on data such that the specification need not change if the form or format of the data changes. The independence of data format from specification of operations includes: insurance that the on-line processing of a request will not be changed if the format (field, length, number of items, etc.) of data involves changes, and insurance that a problem-specific procedure programmed off-line need not be reprogrammed if there are changes in the format of data to which it refers.

The design of ADAM incorporates features which accomplish these aims while maintaining an acceptable level of operating efficiency. Fundamental design features of ADAM include its data structures, dynamic allocation, format and language descriptions, compiler, and asynchronous operation.

The major data structures of ADAM are the file structure and the roll structure. Files contain all the data on which ADAM will operate. They are variable in length and flexible in format. Rolls are a combined dictionary-directory for the files. They contain names for data in the files, short internal forms for the names, and descriptions of the location, format, and size of the data items.

The file-roll structures underlie system operation. Names of data items and names which are data values are transformed into short internal form during the translation of a request. At the same time, the translator retrieves from the rolls the description of the form and format of data items. Programs which perform data manipulation use only short forms for names, thus saving

operating time. Names are stored in files in short form, thus saving space. Just before output, the short forms are transferred back to more familiar alphabets for the user. During data manipulation, programs use the data descriptions retrieved by the translator to find the location, size, and format of data. Thus, the file-roll structure permits data manipulation programs to be written independent of data format, reducing the need to revise programs to accommodate changes in the format, field size, or amount of data in use.

The principle of dynamic allocation affords ADAM its ability to perform many different kinds of tasks on data structures of variable size. Computer resources (core memory space, disk space, etc.) are allocated to the task at hand as the need arises during the processing of a request. When called, special system allocation routines choose a location (for a file, routine, temporary storage area, etc.) and assign an identification to be used in future references. This makes the allocation routines the only ones in the system that know the actual hardware location of each allocation.

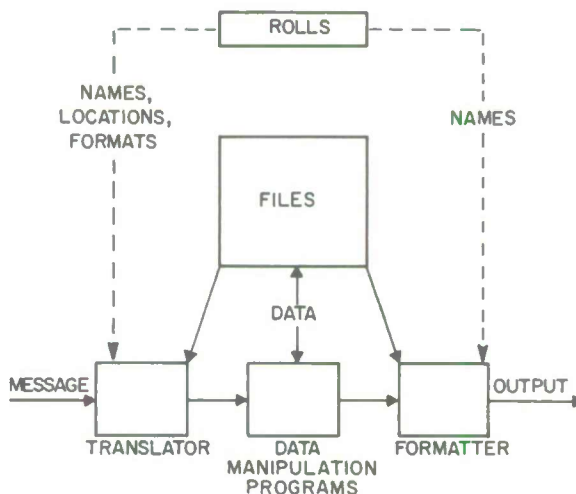

Overall Organization of ADAM.

Allocation functions assign specific amounts of storage, increase allocation size, and release allocations when no longer needed. The core-storage allocation algorithm allocates space from one end of memory for data and from the other end for programs, so that the ratio of memory-for-program to memory-for-data changes to fit the task at hand. Routines are allocated space in core memory only when they are being used. Data storage allocations dynamically move to new locations in core memory when necessary to accommodate increases in their size or to accommodate more routine storage. A single data allocation remains always contiguous, to preserve machine addressing and indexing capabilities. Because routines refer only to the allocation identification and not to the actual location, they are not aware of the moving of data and will automatically address data at its current location. The disk allocation algorithm operates by linking together areas on the disk; the disk allocation program also handles all transfers from disk to core and core to disk, relieving processing programs of the responsibility for following the links. The linking procedure allows the size and location of allocations to change at almost any time. Occasionally the system performs a wholesale re-allocation of disk memory space to make allocations contiguous for more efficient disk-core transfers.

The use of format and language descriptions exemplifies the basic ADAM principles that general capabilities be separated from those specific to an application and that programs be separated from data.

The ADAM translator has been designed to translate a class of languages, rather than a particular language. When the translator is called upon to translate a message, it retrieves from a file a description of the particular language to be used. A description of a language consists of a set of recursive procedures written in a special interpretive code; each recursive procedure corresponds to a syntactic unit of the language.

Language descriptions are stored in a language file. The output of the translator consists of a set of interpretive instructions which are subsequently executed by a processor to carry out the action specified by the message. Format handling of outputs follows a design principle similar to that for languages. User-specified format descriptions reside in a format file. Messages or programs which specify that output is to be produced may also specify the format in which the output is to be presented by naming one of the set of available format descriptions in the file. An output formatting program interpretively executes the specifications of a format description to transform outputs from their internal representation to a form desired by the user.

In the initial version of the ADAM system, the language file contains a description of a basic file-generation language and a basic retrieval language. The format file contains a selection of standard formats for display, typewriter, and printer output. For any specific application, desired languages and format may be described and their descriptions inserted into the files. In particular, revised designs for languages and output formats

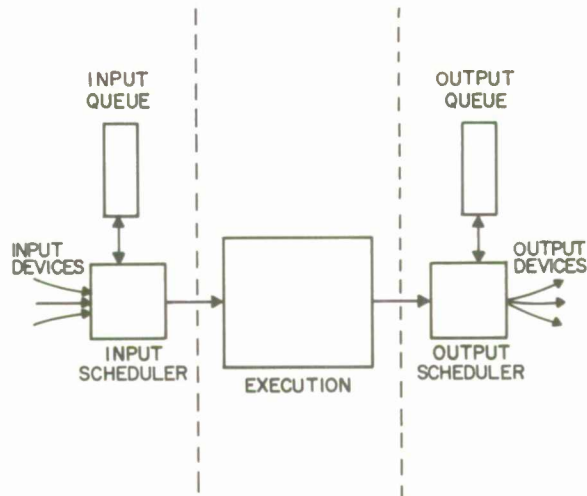

ADAM information Flow.

may be implemented and tested through changes to the files without reprogramming the translator or output-format programs.

The ADAM compiler, called DAMSEL, constitutes the primary mechanism through which a user can program subroutines which perform operations specific to his problem and are too complicated or repetitive to express in an operator language. The compiler accepts IBM 7030 assembly language, IBM 7030 macro language, and ADAM-oriented statements; it produces standard IBM 7030 machine-language binary as its output. Compiled programs must be inserted into the ADAM routine file to be used. In that sense, user-oriented subroutines are considered as "data" for many ADAM operations. Subroutines in the routine file may be executed by other subroutines or as a result of message inputs.

DAMSEL itself allows the usual complement of arithmetic-assignment, conditional, and subroutine-call statements, and includes a macro facility for extending the DAMSEL language. In addition, it provides statements specifically designed to create, augment, modify, and retrieve

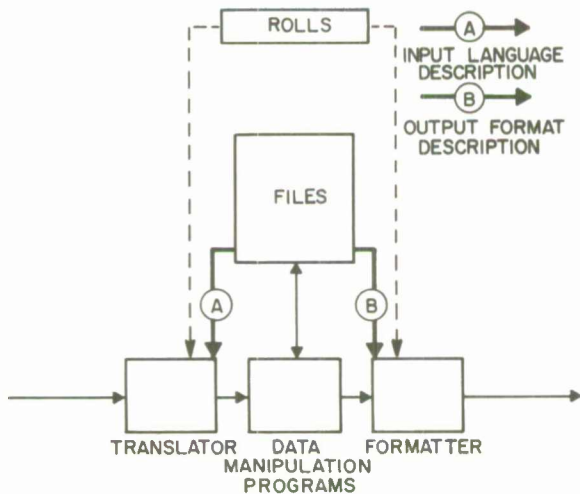

ADAM Data Structures.

data structures from ADAM. File-manipulation statements refer directly to files by name or use names which the subroutine receives as input parameters from other routines or from a message input. In either case, statements in the subroutine are independent of the format of data referred to; data descriptions are retrieved from the rolls when a subroutine is compiled or executed.

Although the DAMSEL compiler constitutes the major means for writing user-specified subroutines, other compilers may be used. All routines must present a standard interface; since they do, routines compiled by different compilers may call one another. In particular, an available ADAM system routine adjusts the interface of subroutines compiled by FORTRAN to be compatible, so that computational routines may be coded in FORTRAN for convenience.

On-line, real-time operation of ADAM brings all its capabilities to bear on the design and evaluation of an information system. Standard file updating inserts items into the data base such as language descriptions, format descriptions, and problem-specific subroutines which have been prepared and assembled earlier. Requests (to generate new files, to retrieve data from files, and to manipulate data) then enter the system as messages from real-time devices (typewriters, display light-pencils, etc.) or as simulated real-time inputs. As messages are received, the system determines their priority and the language in which they are written.

When the internal processing routines complete a task, they request another message, and the message with the highest priority is unstacked. Translation of the message proceeds, using the appropriate language from the language file. The translation result (a list of things to be done) is executed interpretively, and any output formatting required occurs as described by a format from the format file. Pending availability of an output device, the output formatting program delivers the output to be stacked. Another message is then requested. Meanwhile, output is delivered to devices as fast as the equipment per-

mits, or it is stacked until it can be used. The three cycles (input, thruput, output) operate asynchronously from one another. The input cycle synchronizes with the man or machine producing input, and temporarily interrupts thruput to receive and stack a new message. The output cycle synchronizes with the ability of equipment to accept output and temporarily interrupts thruput to initiate a new transfer when a device is available. The thruput cycle operates whenever a task is to be done, oblivious to the interruptions for input and output.

TIME-SHARING SYSTEMS

The Phoenix digital computer, discussed earlier, was designed to be operated on-line in a time-shared manner by multiple users. Each of these users is provided with an input-output console such as a typewriter, teletypewriter, or display unit, and is able to operate the central computer with much the same degree of freedom as if he were the sole operator of a private computer. The key element in the provision of this capability is the concept of "time sharing." This is a computer scheduling and control concept that permits the interleaved operation of a number of programs. Its implementation in Phoenix involves some unusual hardware techniques. In addition, it includes a system of special programs that both supervise the time-sharing functions and underlie and support all other programs written for or by the user.

This system is divided conceptually into four parts: Supervisor or Executive Program, Translator, Debugging Program, and Editing Program.

Supervisor Program

The Supervisor Program supplies an environment in which many users are provided with essentially simultaneous access to the computer. As such, it must permit rapid responses to requests for computation as these originate from each input-output (I/O) console while, at the same time, it maintains the essential independence

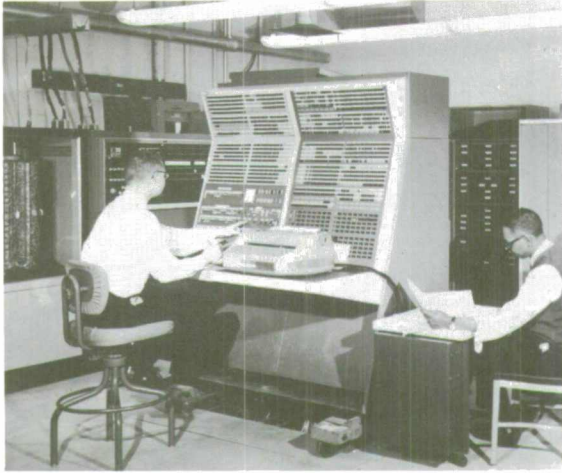

of all jobs and prevents mutual interference among them. In performing these functions, it carries out seven specific tasks:

Initiates and runs jobs, providing a job-subjob chaining relationship.

Provides job microscheduling by means of the scheduling algorithm. (This involves solving the apparent dilemma between giving immediate response to on-line user commands, and providing a fair allocation of computational resources among the various jobs, while maintaining efficient operation of the computer as a whole.)

Assigns I/O units to jobs, and provides useful interfaces between programs and their I/O units.

Assigns auxiliary storage to jobs. (This is another resource-allocation problem, involving a conflict between flexibly meeting differing demands for space and preventing overcommitment of finite resources.)

Creates, maintains, updates, accesses, and destroys files for projects, while solving the problem of simultaneous access to the same file by two jobs assigned to the same project.

Maintains typewriter I/O interfaces, using a flexible "message" concept as a basis.

Administers the file of miscellaneous utility programs, which do not belong to specific projects but which are available to any job upon request.

Translator

Use of the Phoenix computer requires, among other things, the preparation of programs and the issuance of commands. To meet these needs, a single language called PAT (Phoenix Assemble and Translate), and a translator for it, has been designed. It can be used for writing both programs and commands.

The translator is so organized that it may be used as either an independent entity, operating as a machine-oriented macro-assembler, or as a subroutine of another program which can hand over to PAT the task of translating a character string representing a command into machine-usable form.

PAT contains three essential characteristics: the ability to add features to the language in its own terms, which allows the user to create his own commands in a simple and uniform way; the use of a symbol table as the central transformation device, which permits the user's symbology to be transformed into terms meaningful to computer programs; and the organization of programs as nested, named blocks, which provide for the appropriate interpretation of a multiply defined term according to the context in which it is used.

Debugging Program

This tool has been designed to aid a programmer in debugging his program in an on-line environment. It is characterized by such basic features as the ability to interrogate or change the contents of registers in the machine; to search memory for specified data configurations and print out those found; and to run programs under breakpoint control. Because the debugging program uses PAT to interpret the user's commands, the user can define commands of his own, which combine and extend the features provided in the basic version.

Editing Program

The Editing Program is a tool designed to create, modify, and combine files of textual information on-line. It provides for the insertion, correction, and deletion of lines of text, or of individual characters within lines, for output of portions of file texts, and for searching for the occurrence of substrings within the text. The Editor is controlled by using commands translated by PAT, and hence provides the ability to modify and extend the language.

PROCESSING TECHNIQUES

The activities in the data management area are concerned principally with techniques for the manipulation and querying of data files. In addition, MITRE has been engaged in an extensive program of research and development in the area of processing techniques. Its objective is the development of software that will simplify the production and modification of programs for data reduction and simulation.

The overall processing techniques program is divided into three related areas of work:

FAST (FORTRAN Automatic Symbol Translator), pre-compiler to FORTRAN IV for use on the IBM 7030.

FORSIM IV, a general-purpose simulation package related to FORTRAN IV and intended for use on the IBM 7030.

List Processing, under which two different versions of the LISP language are being developed, one intended for use with the IBM 7030, the other with the Phoenix computer.

FAST (FORTRAN AUTOMATIC SYMBOL TRANSLATOR)

FAST, a pre-compiler to FORTRAN IV on the IBM 7030, is especially useful for problems involving many subprograms which reference a large mass of common, structured data. It is basically a translator capable of substituting strings of arbitrary alphanumeric information for input strings of a specific form. By this mecha-

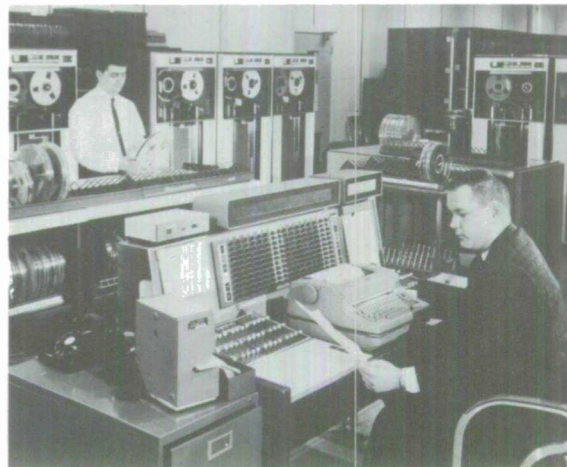

nism of string substitution, for example, it is possible for the programmer to reference an item of data by name without regard to its location, its bit size (if packed), any scaling associated with it, etc. Such information is substituted for the name of the item, by FAST, in a form appropriate for input to FORTRAN. Substitution of strings for items is accomplished by means of a dictionary, called a COMPOOL, which itself is created and maintained via FAST.

FAST also includes, in the FORTRAN program, all required FORTRAN declarative statements (COMMON, DIMENSION, ETC.) either because the declarative statement appears explicitly in the COMPOOL or because the FAST source program has referenced an item whose definition (information string) requires such a declarative statement. Thus, the FAST programmer may reference data by the use of meaningful names alone, avoiding the tedium and occasion for error associated with the generation of the required FORTRAN statement.

In many applications, the data on which a system of programs is to operate is obtained from some source external to the computer on which these programs run, and is not, therefore, in a form directly usable in FORTRAN statements. Here again, the FAST COMPOOL provides the mechanism necessary to translate a convenient notation used by the programmer into the complicated expression required to actually operate

upon the given data. Similarly, if, as often happens, the precise form of the data should change while its meaning remains constant, a change to the COMPOOL (followed by a simple recompilation of the affected programs) could suffice to reflect this change in the operational system without necessitating a change to the actual source language program.

"Category selection" is one of the more powerful features of the FAST COMPOOL. Units of information (items) within the data base generally have more than one property (such as the number of bits allocated, position within a computer word, a scale factor, etc.). In the FAST COMPOOL a single letter, called a category selector, is chosen to represent each property of items. Then, the combination of item name and category selector defines a specific property of a specific item. Further, an expression defining a relationship among properties may appear in the COMPOOL entirely in terms of category selectors and, thus, becomes valid for all similarly definable items of a system.

Generalization of the present program, both in the direction of more complex string manipulation and in the direction of further interpretation of the information being substituted, is under active study.

FORSIM IV

FORSIM IV, a general-purpose simulation package related to FORTRAN IV, has been operational on the IBM 7030 computer since October 1963. It was developed by MITRE as a tool for simulating aspects of the BUIC system. The development of the FORSIM package was also motivated by the fact that no simulation language was available at that time nor likely to become available until mid-1964.

Simulation languages are generally used to simplify the construction of and experimentation with models. Since experimentation may lead to modification of the model, the simulation language should allow the same ease in modifying as in constructing. It should provide facilities to de-

scribe the conditions of the model, to dynamically alter the conditions of the model during operation, to measure model performance at desired times and at the occurrence of desired conditions, and to present a meaningful statistical analysis to the user.

FORSIM provides a variety of facilities for the probabilistic generation of data and for statistical analysis and presentation. It represents an innovation in simulation language technique, since it is constructed, not as a language (i.e., a pre-compiler), but as a subroutine package. Thus, the user of FORSIM IV writes a FORTRAN IV program, calling subroutines as he needs them. Most of the subroutines of FORSIM IV (set-entity, timing, histogram, and statistical routines) are themselves written in FORTRAN IV. The set-entity routines, servicing user-established queues (lists of various types such as push-down lists), are the core of the simulation package.

FORSIM is founded upon the basic concepts of *set* and *entity*. *Sets* are collections of *entities* and *entities* are the basic items which flow through a system (model). To describe a model, one must define a configuration of *sets* and *entities*, the paths which *entities* may follow through the *sets*, the rules for generation, deletion, modification, or delay of *entities*, and the points in the system at which these rules are to be applied. As an example, consider a communication system with the lines, buffers, switches, and terminal points considered as *sets* and the messages as *entities*. As time passes, the messages follow prescribed paths through the network. When messages compete for a single line or reach a switch, a decision as to future movement, or delay, is made in accordance with the specified rules. Normally, in any complex system, the time at which an event is to occur is subject to constant change as a result of preceding events. One feature of FORSIM is its ability to keep track of the occurrence of events and to cause the next most imminent event to occur in an orderly progression of time.

A FORSIM IV User's Guide has been written primarily for the IBM 7030 computer, but FORSIM can be easily adapted to any computer capable of compiling FORTRAN IV, since each command is a subroutine written in FORTRAN IV (exceptions to this rule are the debug feature and the random number generators, which are STRAP-coded).

The subroutine-structure of FORSIM IV provides for the easy expansion of the command set, as well as virtual machine independence. Furthermore, since the FORSIM program is written in FORTRAN, one retains the advantage of familiarity while gaining the effect of a versatile simulation language.

LIST PROCESSING

It is reasonable to classify programming languages into two categories: machine-oriented and problem-oriented. The first category contains such languages as STRAP which, for the most part, make it easier to write the individual instructions of a program, and to organize it into a coherent whole, through the use of symbols to represent numbers. The second category contains such languages as FORTRAN, in which statements correspond in a direct manner to the steps of an algorithm.

The overt purpose of a programming language is to facilitate the task of coding the algorithm into a form processable by the computer. There is, however, another effect: the language itself provides a framework and a conceptual vocabulary which is used by the designer in understanding the task and in creating the algorithm.

More recently, attention has turned from computer applications in performing purely numerical calculations to problems such as the formal solution of mathematical problems, the simulation of human goal-seeking behavior, artificial intelligence, and symbol manipulation. Conventional programming languages have proved to be inappropriate tools for these tasks and, as a result, have given way to list-processing languages.

These languages fall into the machine-oriented and problem-oriented categories mentioned above.

The first of these list-processing languages, IPL, is machine-oriented; but it is oriented toward a machine which does not actually exist. Therefore, it is convenient to think of the machine, which is specifically designed for list-processing, as being simulated on some kind of real machine. IPL is a language which facilitates writing an algorithm in terms of the individual "instructions" of the list-processing computer.

LISP, the "FORTRAN" of list-processing languages, falls into the problem-oriented category. LISP is a relatively difficult language to learn. However, once he has learned it, the designer/programmer has a good tool for conceptualizing the solution of problems in the area of symbolic computation. LISP has found many successful applications.

Data storage requirements constitute some of the major difficulties in implementing LISP. Problems for which LISP is particularly suitable tend to require relatively large amounts of memory. Consequently, many of the attempts to use LISP have been severely limited by the available computer memory.

Two versions of LISP are being developed at MITRE. One, designed for the IBM 7030 and almost complete, is an on-line system providing for interaction with the user by means of a display console and typewriter. The memory problem will be partially solved in this case because of the relatively large IBM 7030 memory. The other version of LISP, being designed for the Phoenix computer, attempts to solve the memory limit problem by providing a system for dynamically relocating subroutines in the main memory and moving them to and from the auxiliary memory as required. It is anticipated that such a program as the MATH-LAB will be able to expand almost indefinitely in the environment of Phoenix LISP.

RETRIEVAL SYSTEMS

A modern computer-based command and control system generally contains a very large data base as a key element of its functional organ-

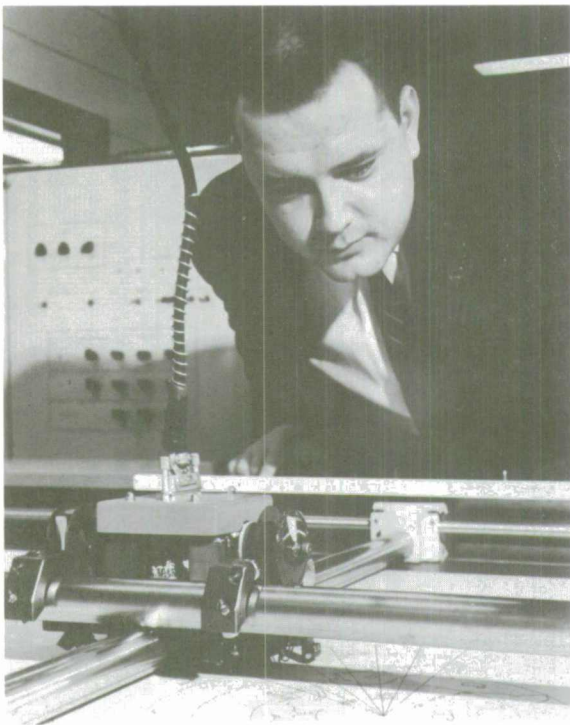

AUTOMATIC DOCUMENT CONTENT ANALYSIS AND RETRIEVAL

Operational military use of messages and documents makes special management demands that cannot be satisfied by traditional library procedures. Therefore, MITRE designed the automatic document content analysis and retrieval program to meet these demands.

A message and document system should accept as input any material whose form is compatible with machine requirements. It should accommodate and analyze large amounts of natural message content relating to a wide range of topics. The content of messages should be coded in a fully mechanical manner, and new content should relate automatically to other relevant content, already in memory. In responding to retrieval search demands, the system should have access to its total resource of stored information, not only to select and appropriate response, but to improve its program for interpreting and responding to these demands. To be reasonably adaptable to differences in contexts of application, such a system should perform these functions without an index, grammar book, dictionary, thesaurus, or other formal constraint.

ization. This data base, depending upon the application, may contain a wide variety of different types of information, ranging from intelligence reports, in the form of raw, unedited English text, to carefully structured tables of mathematical constants. Permissible access times to this data base may vary from a few microseconds or less in the case of an AICBM system, to minutes, hours, or even days in the case of some strategic intelligence applications. In general, however, speed of access is one of the most important effectiveness measures.

The importance of information retrieval in the efficient functioning of a command and control system was recognized by MITRE, and a selective but fruitful program of research and development in the retrieval systems field was consequently instituted within the Corporation.

This program was divided logically into: Automatic Document Content Analysis and Retrieval, ROUT Document Retrieval System, and Computer Processing of Logical Relations.

The requirements of an automatic retrieval system are met most satisfactorily by identifying various statistical properties of documents, and using them as a basis for analysis. The statistical approach applies the most elementary and primitive relation among message units, that of co-occurrence probability patterns. The basic strategy is to proceed as far as possible using these patterns, with a minimum of assumptions about the linguistic or semantic organization of the information within the message structure. The information contained in a message is assumed to be carried by the words that make it up, and by the manner in which they are strung together. It is further assumed that a person generating a message or document chooses words in a non-random fashion and combines them according to semantic and syntactic rules that are regular and, to some extent, predictable. That is, both the

selection of elements and their co-occurrence with other elements are restricted by the contexts in which they occur.

MITRE's program exploits the regularities of these associations among words, ignoring the specific nature of the rules which produce such regularity and, thereby, restricting itself to the statistical features. Once given a set of messages, the frequencies of co-occurrence of each word with every other word within a message are tabulated. When these frequencies are pooled over a set of messages, a matrix is constructed that reflects the overall value of co-occurrence of each word with every other in the set. Eliminating extraneous influences, such as the frequency of word occurrence, relative word position, and message length, a normalized matrix is produced that shows the tendency of two words to co-occur because of their relevance to each other.

When the contents of a message file are represented by a normalized matrix, the values of the associations between the words of a query sentence and the words of the matrix can be used as the basis for assigning weights to each document in the files. The documents can then be ordered on the basis of their relevance to the query sentence. Similarly, normalized matrices can be constructed that reflect the message previously read by a particular individual. Any new messages can be processed, with respect to that matrix, in the same way that the query sentence led to the specification of values for associated words. However, in the message routing problem, values would be assigned to the new message in terms of its similarity to the messages contained in the matrix, rather than the converse (as was done in the case of the retrieval problem).

A prototype model of this analysis procedure has been programmed for the IBM 7090 computer. The successful operation of this model demonstrated the feasibility of the statistical association concept. Subsequent testing of the system provided data that substantiated its validity. Further programming efforts have increased the speed and capacity of the operating system.

ROUT DOCUMENT RETRIEVAL SYSTEM

The ROUT System (*Retrieval of Unformatted Text*) was developed to investigate the feasibility of automatically indexing and retrieving numerous small documents (teletype messages, for example) on the basis of key words that appear in the text. Experimental evaluation indicates that such techniques are workable and fairly efficient.

In operation, documents that are to be indexed automatically must be available in machinable form, i.e., on teletype tape or on hard copy that can be processed by an optical character reader. Words of the text are compared with a stored dictionary and all "hits" are recorded as key words. Alternatively, documents could be read and key words assigned by a human indexer. In either case, the key words, bibliographic information, and (if desired) the text, are assembled into a cross-linked file structure in magnetic disk storage.

Queries are formulated and entered directly into the computer through an on-line typewriter. Any combination of key words, message dates, and originators may be specified. By consulting an internally stored thesaurus, the computer prints out a suggested expansion of the query terms, including such things as synonyms, e.g., "RUSSIA" for "USSR," and subordinates, e.g., "BADGER" for "BOMBER."

The user may edit or accept the expanded query. In any case, the computer prints out the number of items in the file that would be retrieved. Depending upon the selection of the user, either abstracts or texts of selected documents may be printed out on a high-speed printer. Fairly rapid response is made possible by the use of indexing techniques and magnetic disk storage.

In one series of tests, 1000 teletype messages (collected at a military intelligence activity) were automatically indexed in accordance with some 8000 key words. Several alternative retrieval techniques were compared for a number of different queries. The results showed the utility of

having machine-aided query formulation, and demonstrated the general practicality of this approach.

Other techniques investigated included the use of a mathematical "measure" of distances between key words, and the use of documents as aids to the query formulation and retrieval processes. Although these techniques appear promising, some practical computational problems exist for large document collections.

COMPUTER PROCESSING OF LOGICAL RELATIONS

As the use of computers in information retrieval continues to grow, increased emphasis is being given to the analysis of statements to determine their relevance in retrieving data as answers to questions. Selection from a body of statements of a subset relevant to a given question, and determination of conclusions implied by the statements, will require analyses of logical relations. Such analyses are particularly needed in information retrieval systems that use natural language. Natural language use can result in more powerful and more sophisticated operations, but this, itself, means that more demands will be made on formal logical processing.

Recent developments in mathematical logic have made it possible to develop computer programs that can be used both to prove theorems and to establish decision procedures for solvable subcases of the first-order predicate calculus. The approach taken by MITRE follows this second direction.

Work to date has involved both the theoretical investigation of a procedure for deciding whether a given expression of formal logic is or is not a theorem, and the development of computer programs to implement the procedure. The computer programs demonstrate that the procedure is feasible and efficient, and that mechanical theorem-proving can be done much faster than previously indicated in the literature. In addition, the computer implementation has provided a valuable tool for further development of the theory.

The existing programs do not use the computer to full capacity. It would be possible to introduce

a number of expansions that would make the programs more powerful and more comprehensive. However, further work on computer processing of logical relations is being deferred until the collateral studies on natural language processing techniques and on information retrieval can make more direct use of the present results.

DOCUMENTATION

Amory, W. *FAST User's Manual*, SR-13, The MITRE Corp., 1962 (Unclassified).

Baker, J., Vicksell, R. and Spiegel, J. *Program Documentation for Mark I Statistical Association Procedures for Message Content Analysis*, ESD-TDR-63-259, December 1963 (Unclassified).

Bennett, E. and Spiegel, J. "Document and Message Routing Through Communication Content Analysis," *Proceedings of International Federation for Information Processing Congress, Symposium on Optimum Routing in Large Networks*, August 1962 (Unclassified).

Burrows, J. *Program Structure for Military Real-Time Systems*, ESD-64-161, December 1964 (Unclassified).

Fagan, G. A. "STAPP, a System of Organization for Large, Non-Real Time, Monte Carlo Simulations," *Proceedings of Spring Joint Computer Conference*, 1963 (Unclassified).

Famolari, E. *FORSIM IV—FORTRAN IV Simulation Language User's Guide*, ESD-TDR-64-108, April 1964 (Unclassified).

Friedland, E. I. "How to Select the Best Computer: A Conceptual Outline," *Proceedings of Spring Joint Computer Conference*, 1963 (Unclassified).

Friedman, J. "A Computer Program for a Solvable Case of the Decision Problem," *J. Assoc. Computing Machinery*, 10, 1963 (Unclassified).

- Friedman, J. "A Decision Procedure for Computations of Finite Automata," *J. Assoc. Computing Machinery*, 9, 1963 (Unclassified).
- Friedman, J. *A New Decision Procedure in Logic with a Computer Realization*, Ph. D. Thesis, Harvard University, 1964.
- Friedman, J. "A Semi-Decision Procedure for the Functional Calculus," *J. Assoc. Computing Machinery*, 10, 1963 (Unclassified).
- Greenberg, S. A. and Williams, H. W. "Reliability Aspects of Military Real-Time Command Control Systems," *Proceedings of IEEE (MIL-E-CON)*, 1963 (Unclassified).
- Held, J. *USSTRICOM Command and Control Systems Operation Manual: Data File Creation*, SR-101, The MITRE Corp., 1964 (Unclassified).
- Israel, D. R. *System Design and Engineering*, ESD-TDR-64-168, December 1964 (Unclassified).
- Jacobs, J. F. and Bennett, E. M. *Military Information Systems*, ESD-TDR-63-503, March 1964 (Unclassified).
- Jacobs, J. F. "Practical Evaluation of Existing Highly Automated Command Control Systems," *Proceedings of Command and Control Symposium*, Paris, France, 1964 (Unclassified).
- Lafferty, E. L. *Simulation and Data Reduction*, ESD-TDR-64-169, December 1964 (Unclassified).
- Lapadula, L. *STREAM System Manual*, SR-114, The MITRE Corp., in press (Unclassified).
- McCloskey, W. A. *Attack Generator, a FORTRAN Program for Subjecting a System to Attack*, ESD-TDR-63-293, August 1963 (Unclassified).
- MITRE Advanced Planning Subdepartment, *Experimental Air Transport Planning Facility*, ESD-TDR-63-268, July 1963 (Unclassified).
- O'Brien, J. A. "Switching Functions for Simplified Data Retrieval and Display Devices," *J. Assoc. Computing Machinery*, 1963; see also ESD-TDR-63-442 (Unclassified).
- Rial, J. F. *Final Report on the Evaluation of the ROUT Document Retrieval System*, ESD-TDR-64-96, June 1964 (Unclassified).
- Rial, J. F. *Investigation of Search Metric Capabilities*, ESD-TDR-63-167, September 1963 (Unclassified).
- Singer, T. and Schupp, P. *Associative Memory Computers from the Programming Point of View*, ESD-TDR-63-245, August 1963 (Unclassified).
- Spiegel, J. and Bennett, E. "A Modified Statistical Association Procedure for Automatic Document Control Analysis and Retrieval," *Proceedings of Symposium on Statistical Association Methods for Mechanized Documentation*, Government Printing Office, Washington, D. C., in press.
- Spiegel, J. et al. *Statistical Association Procedures for Message Content Analysis* (and Supplement #1, *Mark I Experimental Corpus and Descriptor Set for . . .*), ESD-TDR-63-159, June 1963 (Unclassified).
- Spitzer, J., Robertson, J. and Neuse, D. H. *The COLINGO System Philosophy*, ESD-TDR-64-159, November 1964 (Unclassified).
- Stoller, G. S. *Masked Search Program*, ESD-TDR-64-137 (Unclassified).
- Votaw, D. F. Jr. "Statistical Science and Information Technology," *Proceedings of Second Congress on Information System Analysis*, in press (Unclassified).

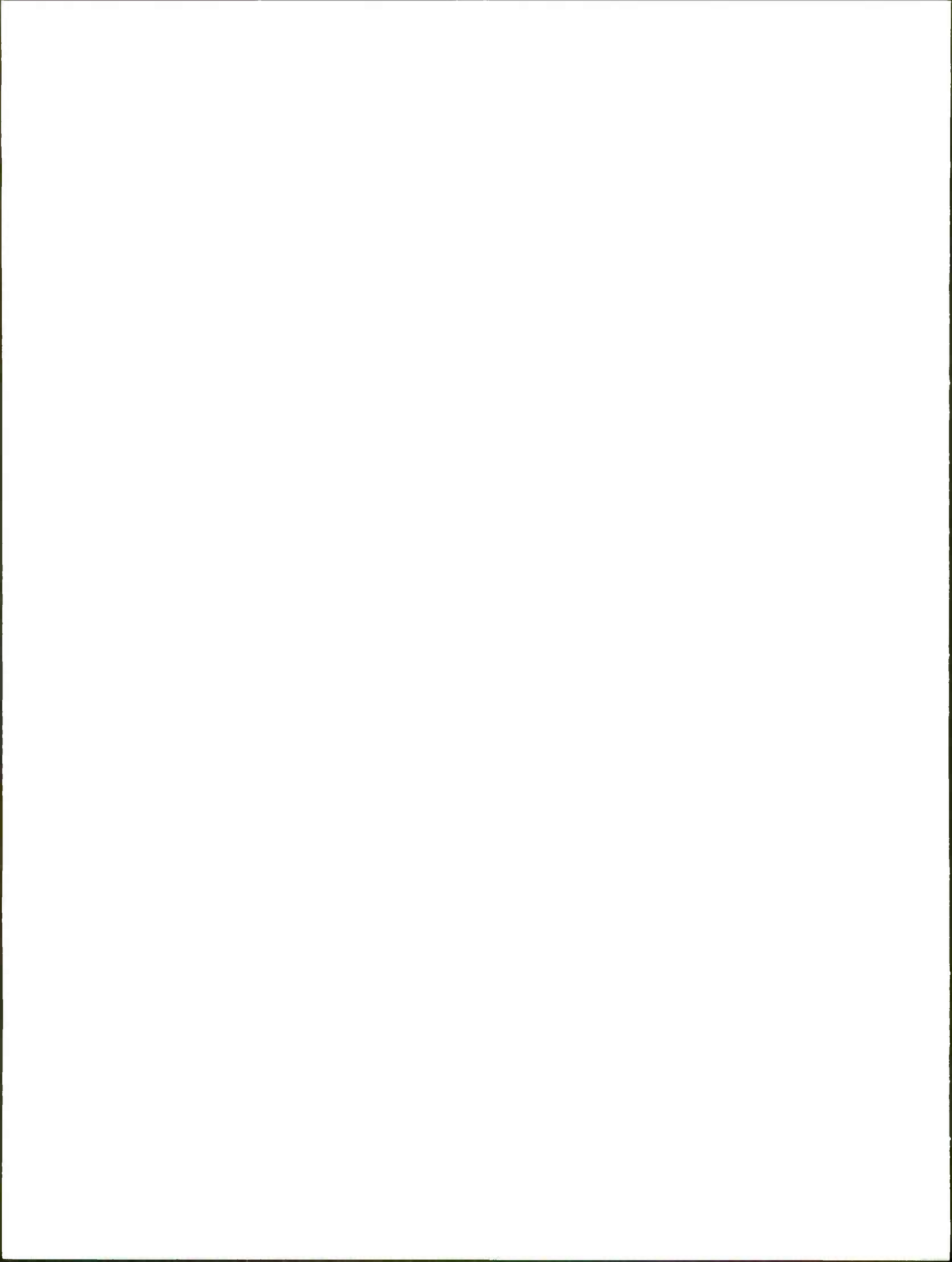

VIII INFORMATION TRANSFER

The introduction of computers into military information processing systems has increased both the scope and speed of systems operations, improving the potential effectiveness of such systems. To fully realize this potential, it is necessary that there be a corresponding development of techniques that will permit human users to participate more effectively in the control process. In particular, more flexible means of on-line information transfer between man and computer are required. If such means are to be provided, the need for procedures and facilities that will allow the user to work in closer coupling with the computer must be taken into account in the early conceptual stages of system design as well as in the later specific implementation stages.

Much of the research and development work at MITRE is related in some manner to this problem of man/computer information transfer. In particular, the development of advanced computer programs, such as ADAM, represents an attempt to provide the user with a greater degree of on-line control instead of forcing him to accept the data processing tools specified in advance by the

system programmer. The work described here consequently complements many of the activities described in the chapter entitled "Information Processing Techniques" but deals much more directly with the man/computer interface. For convenience, this work is described under two general headings as follows:

Natural Language Processing Techniques, dealing with the development of more effective control languages for communication between man and computer.

Information Display, concerning the development of improved techniques for the display of information to the human users.

NATURAL LANGUAGE PROCESSING TECHNIQUES

The users of computer-aided information processing systems require sufficient flexibility in their communication with the computer to permit performance of a variety of functions, such as file manipulation, up-dating, multi-file querying, and report and file generation. These functions are accomplished to a certain extent in existing sys-

tems, but are restricted by the awkward and unconventional nature of the grammars of the associated control languages.

Control languages must be adequate for the area of application, easy for the operator to use, and translatable directly into computer operations. Current languages tend to be limited in the first two of these three respects. Work in Natural Language Processing Techniques is directed toward increasing both the ease of application of control language and the specific utility of the language for operational requirements. A major goal is the adaptation of ordinary English for computer control.

Following early work with the SAGE system, MITRE has been developing input control languages for military information systems that are more and more natural. Near-English query languages have been written for the XD-1, the Experimental Transport Facility, COLINGO, and the ADAM system (FABLE/COLINGO X-1). Early explorations also examined the feasibility of translating basic English into "functional machine English." A Command Language Laboratory Demonstration was designed to provide a problem context for evaluating the approach. This showed that basic English lacks the logical coherence necessary for incorporation into the computer algorithms.

The search for logical models of natural language led to the work in mathematical linguistics being developed at MIT. It was apparent that this mathematically precise characterization of linguistic structure is relevant to command language, and that it can be implemented in the context of a military information system. Work began with the logical specification of a generalized procedure for using English as a query language to derive information from formatted data files. A sentence analysis routine was designed, using as a basis the MIT model, which was capable, in principle, of processing any sentence in English. A structural description for each query sentence, provided by the routine, identifies its elementary linguistic constituents (syntactic and semantic) and the pattern for their

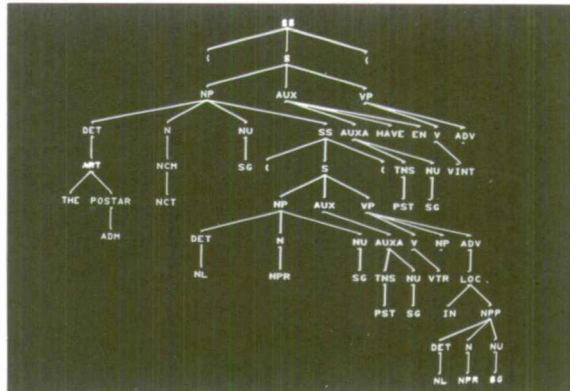

This computer-generated display shows a stage in the development of an automatic linguistic analysis for the sentence, "The general that Johnson met in Washington had traveled 8000 miles."

arrangement according to a transformational generative grammar. These structural descriptions would be related by a translation algorithm to sequences of search and computational operations on files that would produce data appropriate for the query.

The linguistic analysis procedure was implemented as a preprocessor for the type of query language used in COLINGO, after this program was developed as an operational program for data management. The AESOP (Advanced Environmental Structure for On-Line Planning) project on tactical force employment planning provides an experimental context for evaluating the utility of natural language for computer control.

In addition to the natural language sentences analysis procedure, the work has also resulted in ways of representing linguistic structure so that both English and specifiable subsets of English could be defined by systems of grammatical rules that, in turn, could be represented in a computer. A list-processing programming facility (implemented on the IBM 7090 and 7030 computers) was developed for manipulating these complex linguistic structures (as well as other complex data structures). The list-processing facility was used to write programs, incorporating sets of

grammatical rules, that resulted in the generation of all the sentences possible with those rules.

Using the preceding accomplishments as a nucleus, detailed specifications were prepared for an English Preprocessor for COLINGO-class query languages. A number of tasks required for this goal have been completed. A transformational generative grammar has been written for the English sentences that constitute the queries and commands appropriate for the data base developed for AESOP planning. A restricted grammar, containing a subset of the grammatical rules, was prepared for use in debugging the sentence analysis routine. Programming specifications for the sentence analysis routine were completed, and computer programs for the basic components of the routine are running on the IBM 7030. Algorithms were prepared for the translation of preprocessed ordinary English into FABLE/COLINGO X-1 queries.

Structural representations for sentences can be constructed and manipulated on-line as a result of coupling the list-processing facility with the display consoles on the IBM 7030. This mode of control allows changes in the sentence analysis routine to be made directly and simplifies the debugging of the grammar. The programming facility has also been used to design an on-line algorithm calculator that will be used in the AESOP project.

The feasibility of the English Preprocessor has been demonstrated, and significant progress has been made, in the programming implementation of the sentence analysis routine. Further work is required to complete the specifications for the translation algorithm for the COLINGO-class query language. When the algorithm is programmed and the sentence analysis routine is operating for the full grammar, it will be possible to evaluate the utility of natural language for computer control in an experimental operationally oriented context.

INFORMATION DISPLAY

In computer-based data processing systems, it is necessary to provide some other means than

linguistic communication for the input to the computer and for presentation of information to the human user by the computer. Therefore, we are continually studying the special problems relating to information display and other operator facilities.

The studies deal primarily with five topical areas:

Problems of display legibility, working toward a goal of developing procurement specifications to establish acceptable standards.

Display formatting and coding, particularly color coding.

Relationships between displays and the controls used by operators for data input.

Special problems in configuration of display system installations.

Development of both design philosophy and techniques to permit more effective use of displays for data accessing.

Because of a strong emphasis on display utilization, anticipating user requirements, the program has resulted in the establishment of consulting relations between the system design group at MITRE and ESD, in the review of proposed display configurations, and in specific recommendations and guidance for the system design effort.

DISPLAY LEGIBILITY

Conventional specifications for display are based on certain predictors of symbol legibility, such as brightness, contrast, stroke width, edge sharpness, etc. The degree of legibility is not directly emphasized. A set of procedures has been produced for testing symbol and word legibility involving direct assessment of human performance in reading tasks that use display equipment. This approach, with evaluative criteria based on time and error measurements, offers advantages to the display manufacturers and to the ultimate display users.

Legibility requirements are included in the specification for a large-board color display, with projected backgrounds, used in the Headquarters



Useful standards have been obtained through extensive studies of many types of displays. One type of display studied was the edge-lighted plotting board.

USAF 473L System. The National Military Command System (NMCS) has similar legibility sections in the specifications for large-board and console displays. The use of test procedures for legibility and visual discriminability was specified in detail for a display for the range safety officer at Patrick AFB, Florida. In addition to defining the legibility of alphanumeric symbols, accurate identification of line types was required.

These legibility specifications were first used in the displays for the Systems Design Laboratory at Hanscom Field. Work is continuing to improve and broaden the applicability of the procedures. Other problems related to the visual quality of displays which are under study include: screening subjects to perform reading tasks; uncovering visual defects in acuity, eye muscle coordination, and color sensitivity; and the measurement of letters, numerals, lines, and special symbols.

DISPLAY CODING

Color coding of visual information is becoming increasingly more feasible as a result of continuing technological development of electronic display systems. Experimental studies at MITRE

have confirmed the potential value of color coding in providing visual separability among classes in both unstructured and formatted displays.

Color coding has been shown to be superior to a number of other symbolic coding schemes (investigated as alternative possibilities) in speed and accuracy of visual search, and counting comparison tasks. This program resulted in recommendations for the proper use of color coding in display design, and data to permit prediction of the usefulness of color coding in more complex job situations.

This program and the experimental work on design legibility have both resulted in the development and use of computer-based statistical analysis procedures which have since become available for other MITRE/ESD research efforts.

DISPLAY/CONTROL RELATIONSHIP

Human operators may require specially designed input equipment in close conjunction with the information displays to perform certain tasks.

Specific operator input facilities required by the system design program include light-guns, trackballs, and various manual plotting devices. For example, one study (related to height-finding in the 412L SAGE System) using a two-dimensional display system, dealt with the problem of tracking in three dimensions. Other studies, in the area of angular estimation, led to the use of an improved rotary switch for track initiation and monitoring in SAGE and later in the FAA/ATC system. Recent work has included the development and testing of a query-word input panel to simplify operator interrogation of automated data processing systems.

DISPLAY CONFIGURATION

Specification of form and content of displays does not always ensure their effective use. Other overall configuration factors may influence a particular display installation. Among such factors studied at MITRE are the measurement of ambient room illumination and surface reflectances; analysis of light-filtering materials; calibration of light sources; display console design

and layout; design of effective one-way vision screens, as in the SDL Command Post observation areas; design of special ambient-lighting installations, as for the BUIC System; and the development of an edge-lighted plexiglass plotting board for the SNOCAP display system.

A series of experimental studies in the legibility of various symbol fonts for use in televised displays have resulted in the provision of quantitative means to establish the relationship between the capacity and legibility of television display. Such studies may be extended to the transmission of geographic and weather maps, line drawings, circuit diagrams, meters, and indicators.

The results of laboratory work on the effects of the angle of viewing large-board displays on reading ease are incorporated in the display specification for the 473L System and other subsequent installations. The effects of the visual distortion of large-board displays resulting from different viewing angles were examined experimentally to permit the development of a layout in which all of the operators have an adequate view of the large displays. A separate study tentatively concluded that the use of a large, shared display, as compared with separate, individual display facilities, may have a beneficial effect on group performance. A follow-up study is underway to determine the conditions under which this effect may occur.

DISPLAY DESIGN FOR DATA ACCESSING

Following the July 1960 report of the Display Panel of the Winter Study Group for Command and Control Systems, a general revision and development was instituted in the MITRE/ESD display design philosophy. This is reflected in current system design, notably in the 425L NORAD System. The current approach is toward making computer-processed data much more accessible to the human user through more flexible procedures for data storage, processing, retrieval, and display. Ideally, the operator should obtain exactly the data he needs for his job, formatted and displayed in the manner he specified, even under changing job and information requirement conditions.

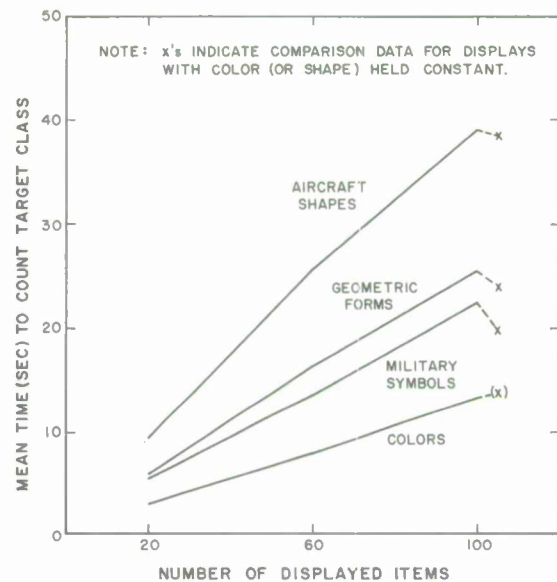

Experimental results confirm that, as compared with various forms of symbolic coding, display color coding is an effective means of providing visual separability among classes of displayed items.

The possibilities of applying the concepts and techniques of automated instruction, using a computer to help train its own users, are being considered in examining the problem of educating operators in the proper use of their computing facilities. Long term gains, however, can only be made through more flexible programming to make the computer more adaptable.

Complex displays and display programs are being developed in the Systems Design Laboratory. For example, a real-time dynamic display of the complicated events during a ballistic missile flight illustrates the capability of the SDL facility, while it provides a useful tool to study the problem of displaying missile flight behavior to a range safety officer and other missile range personnel. Development of this display also requires the production of FORTRAN-compatible, general-purpose computer sub-routines for arranging the display and driving the console.

A study of display use in a simulated command post, in connection with the SDL system model-

ing program, has confirmed that information requirements vary systematically during the sequence of events and circumstances implied in a general war scenario. Furthermore, operators may show consistent preferences in accessing data in one form rather than another.

The AESOP program, investigating the use of displays in computer-aided planning operations, has shown that the availability of a specially prepared work file and associated display may result in a time saving of more than 70 percent in performing a simple task, as compared with conditions where several places in a somewhat larger data base have to be accessed directly by the operators. Future work will examine further the feasibility and utility of work files as aids to data accessing and computer-aided planning.

DOCUMENTATION

Bennett, E. M. and Walker, D. E. *Introduction to the Information System Language Studies*, ESD-TDR-62-335, 1962 (Unclassified).

Botha, B. and Shurtleff, D. *Studies of Display Symbol Legibility; I. The Effects of Line Construction, Exposure Time, and Stroke Width*, ESD-TDR-63-249, December 1962 (Unclassified).

Botha, B. and Shurtleff, D. *Studies of Display Symbol Legibility: II. The Effects of the Ratio of Widths of Inactive to Active Elements Within A TV Scan Line and the Scan Pattern Used in Symbol Construction*, ESD-TDR-63-440, July 1963 (Unclassified).

Duggar, B. C., Autor, S. M. and Moore, D. E. *Visual Search Time as a Function of Display Mode*, ESD-TDR-64-124, in press (Unclassified).

Farquhar, B. B. *The Comparative Discrimination of Visual Number*, ESD-TDR-64-89, in press (Unclassified).

Garvin, E. A. *Individual Differences in Angular Estimation as a Function of Method of Stimulus Presentation and Mode of Response*, ESD-TDR-64-95, April 1964 (Unclassified).

Haines, E. C. *The TREET List Processing Language*, SR-133, The MITRE Corp., in press (Unclassified).

Jones, M. R. "Color Coding," *Human Factors*, December 1962 (Unclassified).

Josephs, J. J. *Notes on Modification and Improvement of the Bausch and Lomb 505 Spectronic Spectrophotometer*, ESD-TDR-62-319, November 1962 (Unclassified).

Kinney, G., Manning, S. and Smith, L. *Further Research on the Effect of Viewing Angle and Symbol Size on Reading Ease*, ESD-TDR-64-633, in press (Unclassified).

Kinney, G. C. and Riche, C. V. *Problems in the Study of Human Data Processing: Response Mechanisms*, ESD-TDR-62-318, November 1962 (Unclassified).

Kinney, G. C., Rouse, W. S. and Sanders, R. M. *Visual Acuity with Two Narrow Band Light Sources*, ESD-TDR-62-320, July 1962 (Unclassified).

Language Processing Techniques Subdepartment, *English Preprocessor Manual*, SR-132, The MITRE Corp., December 1964 (Unclassified).

Matthews, G. H. "Analysis by Synthesis of Sentences of Natural Languages," in *1961 Inter. Conf. Machine Translation of Languages and Appl. Language Analysis*, Volume II, National Physical Laboratory, Symposium No. 13, Her Majesty's Stationery Office, London, 1962 (Unclassified).

- Matthews, G. H. *One-Way Discontinuous Grammars*, ESD-TDR-63-117, 1963 (Unclassified).
- Matthews, G. H. "Discontinuity and Asymmetry in Phrase Structure Grammars," *Information and Control*, 6, 1963 (Unclassified).
- Matthews, G. H. *One-Way Languages*, SR-96, The MITRE Corp., 1963 (Unclassified).
- Matthews, G. H. "A Note on Asymmetry in Phrase Structure Grammars," *Information and Control*, 7, 1964 (Unclassified).
- Morrill, C. S. and Sprague, L. T. "Operator Preferences for Movement Compatibility Between Radar Hand Control and Display Symbolology," *J. of Appl. Psych.*, 44, June 1960 (Unclassified).
- Morrill, C. S. and Davies, B. L. "Target Tracking and Acquisition in Three Dimensions Using a Two-Dimensional Display Surface." *J. of Appl. Psych.*, 45, August 1961 (Unclassified).
- Morrill, C. S. "Teaching Machines: A Review," *Psych. Bull.*, 58, September 1961 (Unclassified).
- Morrill, C. S., Halpert, D. T. and Pilsucki, S. H. *Programmed Instruction: A Selected Bibliography*, ESD-TDR-62-225, April 1963 (Unclassified).
- Shurtleff, D. *Design Problems in Visual Display: I. Classical Factors in the Legibility of Numerals and Capital Letters*, TM-04514, The MITRE Corp., in press (Unclassified).
- Smith, B. E. and Tozer, R. F. *Processing Probabilistic Information For a Dynamic World*, TM-3721, The MITRE Corp., September 1963 (Unclassified).
- Smith, S. L. "Angular Estimation," *J. Appl. Psych.*, 46, August 1962 (Unclassified).
- Smith, S. L. "Color Coding and Visual Search," *J. of Exper. Psych.*, 64, November 1962 (Unclassified).
- Smith, S. L. *Visual Displays—Large and Small*, ESD-TDR-62-338, November 1962 (Unclassified).
- Smith, S. L. "Legibility of Overprinted Symbols in Multicolored Displays," *J. of Eng. Psych.*, 2, April 1963; see also ESD-TDR-63-246 (Unclassified).
- Smith, S. L. "Color-Coded Displays for Data-Processing Systems," *Electro-Technology*, 71, April 1963 (Unclassified).
- Smith, S. L. "Man-Computer Information Transfer," *Electro-Technology*, 72, August 1963; see also ESD-TDR-63-488 (Unclassified).
- Smith, S. L. "Color Coding and Visual Separability in Information Displays," *J. of Appl. Psych.*, 47, December 1963; see also ESD-TDR-63-470 (Unclassified).
- Smith, S. L. and Thomas, D. W. "Color Versus Shape Coding in Information Displays," *J. of Appl. Psych.*, 48, June 1964; see also ESD-TDR-63-483 (Unclassified).
- Smith, S. L. and Duggar, B. C. *Group Versus Individual Displays for a Search and Counting Task*, MTS-15, The MITRE Corp., November 1964 (Unclassified).
- Smith, S. L., Farquhar, B. B. and Thomas, D. W. *Color Coding for Counting and Comparison Tasks Using Formatted Displays*, SR-134, The MITRE Corp., in press (Unclassified).
- Walker, D. E. and Bartlett, J. M. *The Structure of Languages for Man and Computer: Problems in Formalization*, ESD-TDR-63-474-10, January 1964 (Unclassified).



IX **SYSTEM STUDIES**

The term "System Studies" denotes those MITRE research and experimentation activities that are concerned with military systems as a whole. In this area, four different types of activity have been undertaken: command planning, AESOP, exercise and evaluation, and life support. Command planning deals with the problem of providing optimal computerized information systems which support and/or augment the human decision maker. This area includes the role of the commander in a modern military system, the development of planning models, the analysis of planning structures and procedures, and the development of planning concepts. AESOP (Advanced Experimental Structure for On-Line Planning) is a set of programs focused on the application of computer technology to limited-war operational planning and plan execution. Exercise and evaluation is concerned with the application of a laboratory-based testbed, located in the Systems Design Laboratory, for the evaluation in a controlled environment of new computer hardware and software intended for use in military information systems. Life support is concerned

with the study of the problems associated with the maintenance of life and work efficiency in command and control systems operating under conditions of stress.

COMMAND PLANNING

Command planning provides continuously "optimal" computerized information systems which complement and support man in making complex judgments. Models are constructed in a computer which represents the system under examination. The commander can then "experiment" with alternative actions and observe the model system's responses. In this way, he develops judgmental skills and improves his confidence. By such means, human skills can be brought to bear most effectively in seeking out feasible plans and in developing, testing, and selecting suitable classes of alternative plans rapidly, in a complex and changing environment.

A number of attacks have been, and are now being made on this problem. Some of the related work is outlined here.

ROLE OF THE COMMANDER

The commander must have an up-to-date awareness of those elements of his physical and information environment which actually or potentially may affect his command. He must also be able to predict accurately the nature of a wide range of possible inter-actions among elements of his command and between his command and its changing environment.

Because of the tremendous complexity of the commander's tasks, he must be able to operate effectively with his staff and computer aids.

The problem of the commander's role is of continuing and widespread interest. Some of the more specific items studied are:

The need which a commander feels for molding his staff aids (including any computers) to his way of doing business.

A preliminary analysis of functions which occur in a generalized decision system.

An analysis of the possible developments which hinge upon such uncertainties.

Paramount emphasis is being given to the problem of interface between man and machine. This interface must be flexible in order to ease the communication of man to machine and vice versa, and thus optimize the degree to which man can mold the computer to his way of doing business. Many projects are currently in progress along these lines including COLINGO, ADAM, and Phoenix.

PLANNING MODELS

Idealized models are needed to study any natural process, and particularly complex experiments. MITRE's focus has been largely on planning models such as 473L. Currently, the AESOP project described elsewhere in this report, is being emphasized. In addition, an applied research project on Threat Evaluation and Action Selection (TEAS), which ESD had contracted to industry, was closely monitored.

ANALYSIS OF PLANNING STRUCTURES AND PROCEDURES

Past analysis has included the structures and procedures associated with the Air Force Command Post at Headquarters USAF in connection

with the 473L system. Recently, the AESOP program has introduced a new study of planning structures and procedures. In addition, several studies have been completed over the past two years in connection with USSTRICOM, including:

An analysis of USSTRICOM command features, including the organizational framework and J-staff functions and activities.

A study of the USSTRICOM planning problems and requirements for planning aids.

A proposal for an improved systematic approach to some of the most complex problems of contingency planning. This has been termed the "parametric response planning concept."

Development of effectiveness criteria for comparison of alternatives in the USSTRICOM planning process.

PLANNING CONCEPTS

Considerable activity has been connected with the development and demonstration of machine-aids for planning systems. This has attempted to set a long-range framework in which Project AESOP might expect to perform in the next five years.

Interim editions of a long-range plan for MITRE operations have been produced and further refinements and expansions of it are in process. The effort is intended to provide a document which is sufficiently flexible to adapt to changes which may reasonably be required, and is at the same time sufficiently motivating and specific to guide the selection, and encourage the stability, of selected problem areas for specific study.

AESOP

The problems associated with the application of computer technology to the planning for and/or conducting of limited wars have not received the same magnitude of attention as have the problems associated with defense or all-out, general wars. Much, therefore, remains to be learned regarding the role of computer-based information-processing and decision-aiding systems in limited-war problems.

UNCLASSIFIED						DATE: 04 07 68	
LN	NAME	COL1	COL2	COL3	COL4	COL5	
001	A-C	RB-000	RB-00C	RF-101A	RT-33A	C-130C	
002	TAKEOFF	0550	0550	0100	0570	0000	
003	FUEL-CAP	4493	4300	2200	303	0000	
004	A-C	F-105H	F-105D				NEXT PAGE
005	TAKEOFF	3510	3530				PREV PAGE
006	FUEL-CAP	502	1100				NEXT SECTION
007	BOMBS-1000	2	4				PREV SECTION
008	AIRFIELDS	RUNWAY	CONDITION	JPAVAAIL	BOMB1000		RESTORE
009	ABDAN	7000	OPEN	70000	300		
010	AMAZNEST	5000	FAIR	30000	170		
011	AMAZNORTH	4000	GOOD	70000	170		
012	BATMAN	11000	OPEN	150000	300		
013	CEZUL	9000	GOOD	60000	1010		
014	HAFADAN	5000	POOR	40000	300		
015	ISTAHAN	10200	OPEN	120000	1010		
016	JASK	5000	FAIR	00000			
017	KERMAN	9000	OPEN	40000			
018	KERMANSHAH	5300	FAIR		50		
019	KHURABAD	7000	POOR				
020	MIRJANA	7000	OPEN	10000			
021	NOI	9200	POOR				
022	SHIRAZ	12000	OPEN	10000	100		UPDATED
023	SULTANABAD	8000	GOOD	40000			1-81-68
024	TARHAN	8000	OPEN	10000			

A notebook file containing data obtained from several system files of the AESOP booster system is displayed at an SDL display console. The AESOP system is used to simulate limited war operational planning on line.

Limited war is characterized by the possibility of multiple, potentially concurrent wars; by recurrence; by wide diversity of geographic, climatic, logistic, operational, and political contexts; and by the need for great flexibility of response. This strategic diversity places an unusual burden on the planner, yet flexibility and speed of response are paramount.

The Air Force planner, for example, must, in addition to surmounting the problems implied above, confront those problems associated with the complexities of the tactical air-power organizational structure. The operational efficiency of this force depends heavily on its compatibility with the environment in which it will operate. This compatibility is determined to a significant degree by the quality of the planning that precedes the deployment and employment of a given force.

Because many of the problems referred to are new and so little is known concerning the power of computer technology to aid in their solution, it was felt that an experimental effort that concentrated its attention on this area could have a high payoff. This effort was named AESOP (Advanced Experimental Structure for On-Line Planning). The purpose of the exercise and

evaluation aspect of AESOP is to provide a controlled environment in which a variety of information-processing methods may be tested to evaluate their limitations and capabilities for employment planning.

In order to expedite the initiation of the program, it was decided that the study vehicle would be an Air Force planning function whose processes and procedures could be bounded and replicated relatively quickly, and which was bounded by force-employment planning at levels above and below it in the overall planning hierarchy. When desired the focus of attention could be shifted to these other levels. The evaluation program described below utilizes, as the vehicle for experimentation, the planning processes and procedures associated with "next day" operational-force-employment planning at the Tactical Air Control Center level of an Air Force Component of a Joint Task Force.

DEVELOPMENT OF ON-LINE CONTROL TECHNIQUES FOR OPERATIONAL PLANNING

One of the significant goals of AESOP is to provide on-line generation and modification of the decision structure and the computational algorithms within the computer.

The military planner is provided with a set of tools which he can adapt to fit his needs. While the system is on the air he can reformat his data, generate computations or ask questions of the system in his own language. This "on-line control" of data processing, has been developed in response to the need of a military commander to be able to mold his staff aids (including computer) to his way of doing business. Such an approach gives free rein to the ingenuity and imagination of military planners while providing them with the computational speed and memory capacity characteristic of computers.

The initial AESOP manual model of operational planning is in operation. Computer programs providing automated on-line controlled, data-processing assistance to the planning process are now being gradually added to the model to permit evaluation of the effectiveness of on-line control techniques. As these programs become avail-

able, their utility and effect upon the planning cycle will be evaluated by the System Exercise and Evaluation Project.

A display-oriented, information-retrieval system (the "Booster" system) has been constructed for the IBM 7030. This system contains the programs necessary for generating files of data which can be manipulated by the computer, and an on-line input language for use in manipulating both files and file entries.

An operator may call for the display of any file contained within the system base. If there is too much data in a file to fit on a single display, the data is broken up into pages and sections. Thus, the display surface behaves like a window on the file which can be moved in two directions, horizontally and vertically. Page turning and section turning can be accomplished by use of a light pen, pushbuttons, or a typewriter input.

On-line control is accomplished in the current AESOP program by the use of what might be called a computer notebook. This notebook consists essentially of a number of displayed empty files into which an operator can insert information on-line. He can use these "blank pages" to gather together in one spot the pertinent data from many general files to use for a specific task or procedure. The data on this page can be used, for instance, to decide how many aircraft can be refueled and rearmed at each base. An operator could also use such a notebook for entering control information or data into the computer. On-line data-manipulation and editing operations are continuously being defined and programmed to make it more convenient for an operator to obtain the maximum use of his notebook.

Complex information-retrieval systems require on-line operator languages for man/machine communications. Typically, inputs are by means of a typewriter. The typing process is often both slow and unreliable. Consequently, in order to prevent an operator from making syntax errors, a subset of the input language for the booster system has been programmed to be placed on a display in the form of a tree. An operator then will be able to write an input message by using a

light pencil alone. An experiment will be run comparing this approach to the typewriter case in order to test the desirability and utility of the tree format.

A list-processing language called TREET has been developed under the MITRE Natural Language Processing Project. This language permits the development of a powerful set of on-line commands. One variation of the language, "OAK-TREET-I," has been developed to permit the operations planner to set up numerical computations, on-line, in the form of trees on the CRT face and then to store or execute the computations. This facility will be integrated with the booster system to permit data from the booster files to be used in the mathematical expressions.

EXERCISE AND EVALUATION

A laboratory-based testbed has been designed and placed in operation in the ESD/MITRE Systems Design Laboratory. This testbed provides a controlled environment in which new or proposed computer hardware and software can be evaluated for its utility in military information-processing systems.

Present work on the testbed is addressed to the following objectives:

Evaluating generalized, on-line computer aids applicable to operational military planning.



A group works toward a better understanding of a computer-based system in the Systems Design Laboratory.

Providing an integrating mechanism for the evaluation of hardware and software products being generated by the MITRE programs described elsewhere in this report, particularly the ADAM generalized-data-management system. Simulating Air Force planning processes and procedures pertinent to limited war.

Developing techniques for the design of military information-processing systems.

The accomplishments of the exercise and evaluation program to date are as follows:

A doctrinal replica of a manual Current Plans Division of an Air Force Tactical Air Control Center has been installed in the Systems Design Laboratory. This replica includes the information inputs, communication networks, terminal and connections (dummy), forces/resources data base, internal processes and procedures, and the outputs associated with the operation of the Air Force Tactical Air Control Center operating in a Joint Task Force context.

A limited-war scenario that provides the "driving" environment for the exercising of the planning function has been generated.

A series of shakedown runs of the manual planning replica has been completed.

A preliminary set of test and measurement procedures applicable to the evaluation of manual and manual/computer assisted "next day" operational planning at the Tactical Air Control Center level has been developed.

An initial comprehensive test program (AESOP Test Series I/1: Initial Evaluation of Computer Booster System I/1) has been developed for evaluating the effect of the addition of certain first-generation on-line computerized clerical, computational, bookkeeping, and decision aids on the performance of planners operating in the Current Plans Division of a Tactical Air Control Center.

A "pilot experiment series" has been initiated to determine the feasibility of the test concepts (AESOP Test Series I/1) to evaluate the validity of existing system test and measurement

techniques, and to develop new techniques.

In the immediate future the exercise and evaluation program will concentrate on the following: The empirical evaluation of the first generation of on-line computer aids (Booster System I/1) for operational-force-employment planning.

The development of additional test and measurement techniques.

The expansion of the limited-war scenario now utilized in the testbed and the development of new, enlarged scenarios necessary for simulating and evaluating force-employment-planning processes at command levels above the Tactical Air Control Center.

The replication of the manual planning processes, procedures, and environment that take place at the command post and headquarters of an Air Force Forces Component of a Joint Task Force of approximately corps size.

The development of computer-based, consequence models for determining the effectiveness of plans produced by the planning functions that are replicated in the testbed.

The development of test plans for the evaluation of the second generation of on-line computer aids for operational planning.

SYSTEM MODELING — GENERAL WAR

Along with the development of system modeling techniques, there has been continuous improvement in procedures for simulating the environment in which system models are to be tested and providing for monitoring and control of system exercises. The most ambitious undertaking in this area is represented by the attempt to provide automated generation of a general-war scenario and environment for exercising a system modeled as a JCS alternate command post.

Simulation techniques have been developed and successfully applied in the context of MITRE's specific system design projects.

The Gross Engagement Analyzer computer program, developed for general-war scenario generation, has been used to support a variety of analytic studies comparing missile exchange strategies.



A view of gross feasibility planning with computer assist.

Development of the general-war scenario generation capability is being continued with the intention of providing a more detailed simulation.

The final system will contain three basic sets of programs: the previously mentioned Gross Engagement Analyzer (GEA), a Detailed Plan Generator (DPG), and a Plan Interaction Generator (PIG). When completed, the DPG will accept pairs of strategies for the opposing countries from the GEA output and prepare detailed war plans for both sides. These, when operated upon by the PIG, will produce a simulated war containing a detailed description of the sequence of events and their interactions. The view of events is that which would be seen from a Command Post. Consequently, it would be desirable to be able to simulate the sensor and communications systems which supply information to the Post. A program which will provide such a simulation, including the effects of system degradation and outages, is being developed.

LIFE SUPPORT

The design of command and control systems requires an integrated set of specifications for pro-

tective conditions and facilities to help guarantee personnel survivability as well as the maintenance of optimum personnel performance under both peacetime and wartime stress conditions. The failure to specify such appropriate design controls may often produce environmental conditions capable of degrading any performance originally specified for the total system. As a result, efforts were undertaken to integrate appropriate personnel survivability requirements into command and control system design specifications. Such specifications included the full range of peacetime and wartime stresses which might operate to degrade personnel performance and survivability.

A basic human problem in the design of command and control systems is to provide an atmosphere capable of sustaining not only life but also work efficiency. The atmospheric environment includes pressure, oxygen, carbon dioxide, temperature, humidity, and the like. Specification of the ranges within which man can comfortably operate was examined. Following this study, human tolerance to ground shock and low frequency vibrations were considered. The principal threat, it was concluded, coming from such shock conditions did not reside necessarily with the high G forces but rather with whiplash and the associated flailing of extremities and with human impact against equipment. Recommendations were made regarding the necessity for considering personnel restraining devices not unlike those used by pilots in high performance aircraft. In answer to a specific requirement to study the possibility of catastrophic failure in the external air circulation system to the 425L System Combat Operations Center, a study was done specifying such effects on the personnel involved. This study examined some methods and costs of available techniques for regenerating the atmosphere in a closed space. Following this, studies were made of human survivability in an environment where the threat came from chemical and biological agents. A report was issued examining these non-conventional weapons and specifying their effects upon personnel as well as reviewing some means of defending command and control systems from

such attacks. Continuing our studies in subterranean command posts, closed ecological systems degrade rather rapidly in operational effectiveness under various stresses. These underground facilities raise serious problems that are not important in the case of facilities located on the earth's surface. Humidity and temperature control as well as atmospheric regeneration become keys to the survivability of the personnel involved. The radiological hazards from thermonuclear war was a subject of still another study. This study reviewed the research in radiation biology in order to give some indication to system designers as to whether personnel can be protected by means other than sheltering. It was concluded that there are several experimental methods that may serve to extend survivability. Lastly, a manual which included very late findings on radiation effects was issued to indicate that a level of protection would be required for all command and control personnel such that any individual's absorbed radiation would be below 100 roentgens, a level still high by peacetime standards.

DOCUMENTATION

- Adams, H. W. *Controlling NEACP Evolution*, TM-3367, The MITRE Corp., August 1962 (Unclassified).
- Adams, H. W. et al. *Recommended Applied Research Program. Design Methodology*, TM-3184, The MITRE Corp., October 1961 (Unclassified).
- Degan, J. W. *System Sciences Research*, TM-3126, The MITRE Corp., July 1961 (Unclassified).
- Degan, J. W. *System Sciences Research Program*, TM-3157, The MITRE Corp., August 1961 (Unclassified).
- Kapper, F. B. *RODAT: A 7090/7030 Program for Rough Damage Assessment*, TM-3879, The MITRE Corp., September 1964 (Unclassified).
- Votaw, D. F. *Recommended Applied Research Program. Organizational Sciences*, TM-3185, The MITRE Corp., December 1961 (Unclassified).

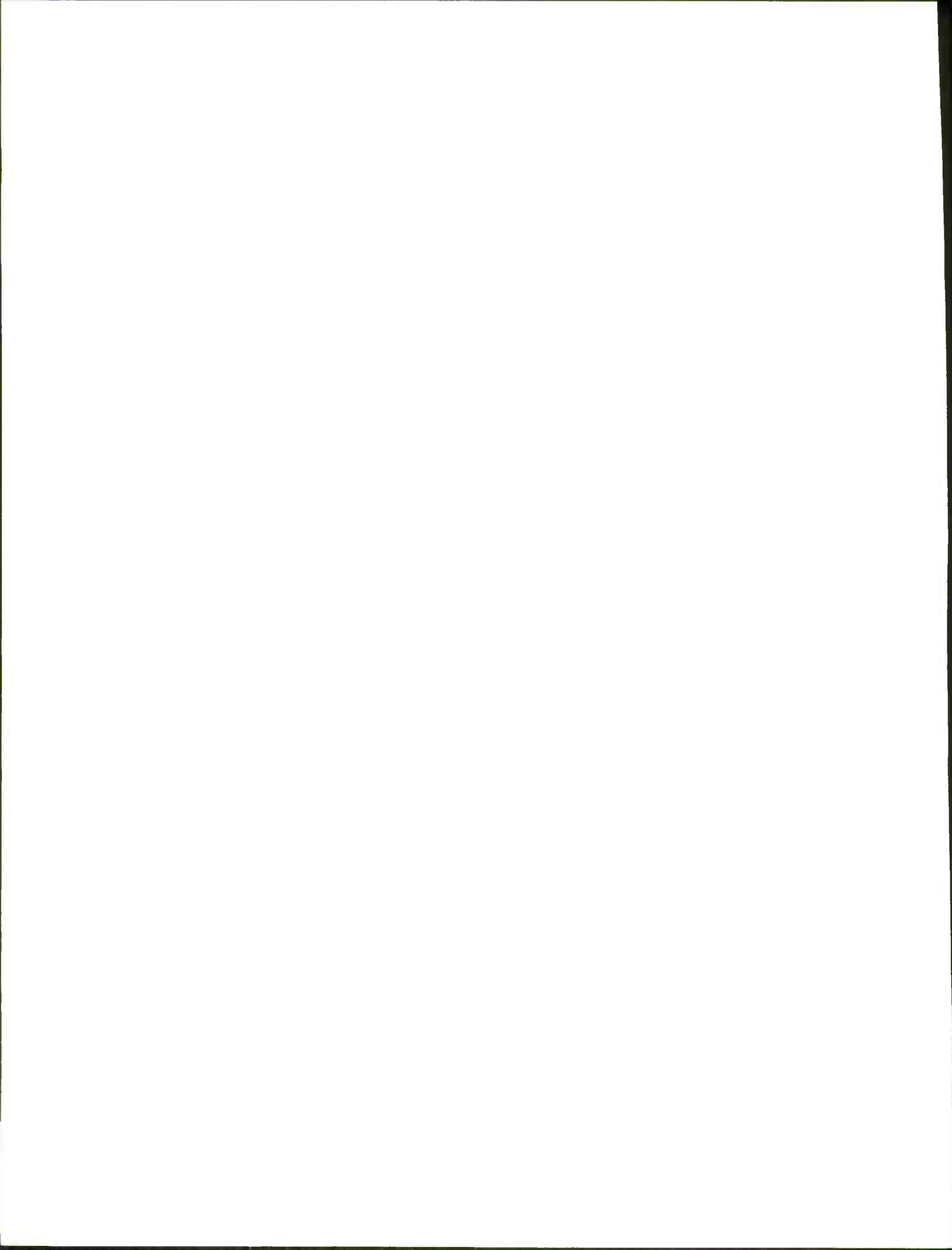

X MATHEMATICAL STUDIES

The technological base required in the area of systems and aerospace mathematics includes techniques and methodologies that are responsive to the needs of the systems designer and have application to current problems of information and communication systems development. At the core of these techniques and methodologies is the requirement for a solid mathematical foundation which can provide both the basic language for describing and formulating the system being designed and the criteria for determining what problems are solvable and what methods of solution or approximation are applicable.

TRAJECTORY ESTIMATION AND ERROR ANALYSIS

Mathematical development of trajectory estimation and error analysis evolved in two phases: the first, applied research, is directed to specific systems with limited objectives; the second, theoretical, is directed to the development of a general, unified approach applicable to almost all estimation problems. The disciplines being developed under the second phase strengthen MITRE's role

as technical advisor to ESD. They are applicable to advanced concepts in the areas of trajectory estimation, system feasibility, and calibration studies.

During Phase I, considerable mathematical treatment was focused on a tristatic radar system. This system consists of three ground-based radar installations with a "known" geometric configuration. Each site furnishes range, range rate, and range acceleration measurements. Of particular concern were (a) serially, uncorrelated, nonstationary random errors in the radar measurements; (b) site location uncertainties; and (c) lack of precise knowledge of some of the physical constants such as the earth's rotational velocity, gravitational constant, and time.

A novel approach was developed to handle trajectory estimation problems concerned with satellites and missiles subjected to thrusting maneuvers in nonvacuous atmosphere around an oblate earth. However, the subsequent analysis was specialized to the problem at hand, namely, the conventional satellite orbital motion.

The trajectory estimation with the associated precision evaluation was based on the statistical least square smoothing technique.

The results of the analysis permit (a) the best estimates of the trajectory parameters, (b) the best adjusted values of the measurements, and (c) adjustments for the station location coordinates and the physical constants.

Investigations related to advanced concepts were conducted during Phase II. In addition to satellite tracking, a modern range instrumentation system requires the capability of self-calibration. Precisely, this involves "accurate" determination of the unknown non-random error characteristics (error model) associated with each measurement channel. Evaluation of a proposed system in terms of precision of performance is also an important problem.

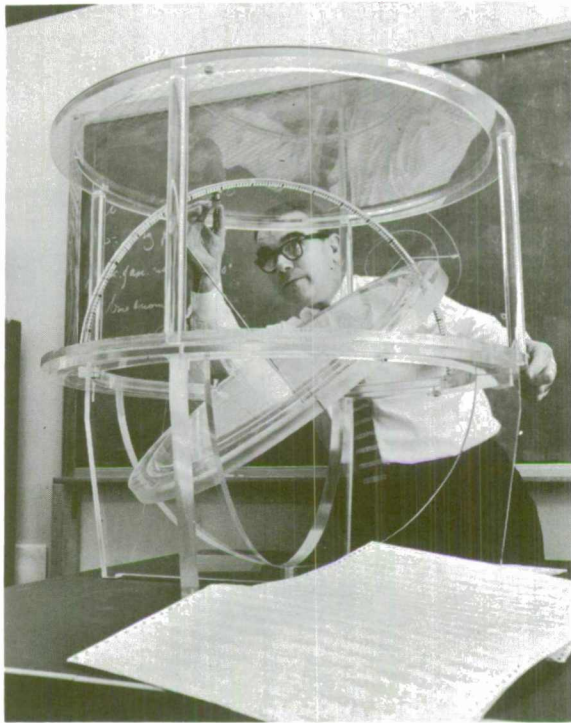

This three-dimensional model, designed and fabricated at MITRE, is used to determine the position, in space, of a satellite for which the orbital elements are known.

Analytically, all these problems can be treated as topics under the heading, "estimation." Redundancy of the available data becomes the key factor to the success of any estimation procedure. In almost all systems, data available from the measurements at one instant of time is insufficient to estimate the parameters to an acceptable degree of accuracy. However, sufficient redundancy of data often exists when one considers all the data points along a trajectory. This requires the introduction of orbital constraints to the estimation problem which, in turn, requires "major" reformulation of the classical techniques. A more comprehensive investigation of a general formulation of the estimation problem was, therefore, warranted.

Kalman's work provided a unified theory for handling complex estimation problems. Means of extending the original theory (strictly for linear systems) to handle non-linear systems required careful analysis.

The novel features of this formulation include, first, a "completely" general system model in which "all" the uncertainties in the dynamical description of the system, including geometry, can be incorporated; second, nonstationary, correlated measurement errors, and also nonrandom errors caused by bias, timing, and refraction, for example; and, third, incorporation on different types and numbers of measurements.

A distinguishing feature of the approach is that the data processing is performed in a sequential manner unlike the *en masse* data reduction required by use of the conventional technique. It allows continual improvement of the estimate as the computation progresses from one data point to the next.

AEROSPACE COMMUNICATIONS FOR COMMAND AND CONTROL SYSTEMS

Anticipating the future development of sensory devices for detection and reconnaissance purposes, MITRE has created mathematical models to develop a system that provides these devices with a real-time warning capability. Such a real-time

warning system would utilize reconnaissance satellites, communication satellites, aircraft, and land-based detection stations, each with advanced transmitting and receiving equipment. Its objective would be to detect missile launchings and the mass buildup of forces, and to transmit an immediate alarm to an appropriate command post as well as to send back reconnaissance pictures taken over any part of the world.

The great potential afforded by this use of satellites for information and communications systems motivated the development of mathematical analysis and geometry, and of a package of computer programs, the Aerospace Communication and Display Package (ACDP), for dealing with this type of problem. The nature of the problem is dynamic; that is, it encompasses the continual motions of the earth, stations, and satellites. It involves the use of highly complex calculations, in conjunction with large amounts of data to be processed, and presents difficult problems whose solutions in real-time necessarily require the use of a modern large-scale digital computer.

The analysis can be used to determine the number of satellites needed and the appropriate orbits for their motion. It determines, in conjunction with the ACDP, the times when it is possible for any combination of space vehicles and ground vehicles to communicate with one another, and also the times at which this communication may be interrupted because of the dynamics of the system configuration. The program may also be used to assess the loss in communication potential when one or more of the satellites or stations is knocked out, and, similarly, the gain in communication potential when additional satellites or stations are inserted in appropriate orbits or locations.

The ACDP computer programs deal with communication between any two stations, each of which may be on the earth or in space, not only via a system of communication satellites but also via belts of dipoles, the moon, ocean cables, transmission lines, etc., or combinations of these.

Future plans for the ACDP will provide a technique that will enable it to respond to queries by displaying, on a cathode-ray tube, all the satellites

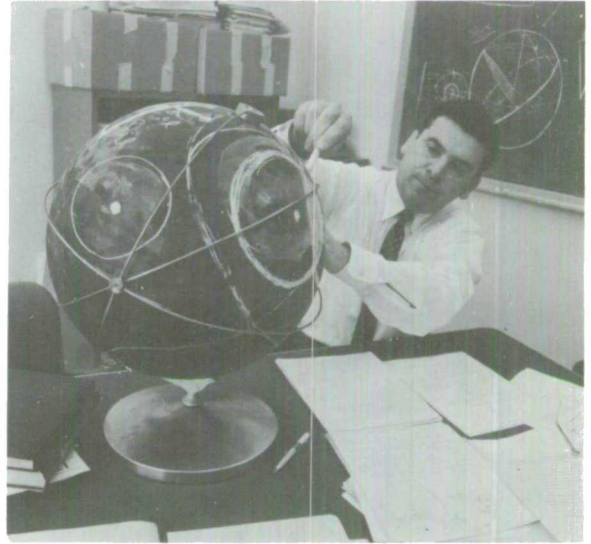

The analysis of problems relating a satellite orbit to a configuration of ground stations is aided by this globe which is used as a three-dimensional chalkboard.

within view of any given station at a chosen time, or show the targets within view of any given satellite at a chosen time. In addition to determining paths by which a detecting satellite may transmit information from any part of the world to headquarters in real-time, the ACDP will respond when a route is cut or knocked out. It will, in fact, select and display all of the remaining possible alternative communication routes, or select the most desirable routes in accordance with a specified criterion.

PERSPECTIVE PROJECTIONS

Attempts to represent the surface of the earth in a two-dimensional plane have their roots in antiquity. As mathematical sophistication has increased, the technique of making maps has developed into a fine art. Standard forms of maps have evolved, each of which demands much care and time to produce. The properties peculiar to each map form determine its usefulness as a visual aid or analytical tool.

As we moved into the space age, the cartographic needs of scientists and military commands

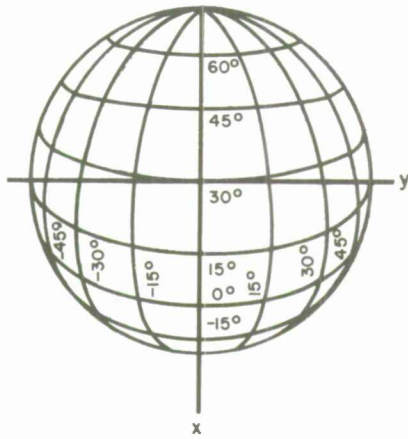

Geometric Projection of the geographic grid with the point of projection in a satellite 4000 milcs above 0° longitude, 30° latitude.

changed radically. This has been particularly noticeable in the areas involving satellite analysis. For example, a commander wants a visual display of the terrain visible to a given satellite, or he wants to know which radar sites will have contact with a satellite on a given orbit. A radar site analyst wants a device which will give reasonably accurate information regarding azimuth, range, and elevation as a satellite passes over, or he wants to determine the location of tracking stations so that adequate coverage can be maintained during critical phases of a satellite's mission.

Investigations of these needs indicated that a computerized mapping technique was necessary. Toward this end, a family of projections, known as "Perspective Projections," has been analyzed. The observer's eye is taken as the point of projection, viewing a portion of the earth around the center of projection. This part of the earth is projected onto a plane perpendicular to the line joining the point of projection and the center of the earth.

If the point of projection is at the center of the earth, the projection is called "gnomonic"; if the point of projection is at the surface of the earth, it is "stereographic"; and if the point of the projection is at infinity, the projection is "ortho-

graphic." Finally, if the point of projection is some finite distance above the earth, the mapping gives an image of the earth as it might be seen from an orbiting vehicle, and this projection is called "geometric."

The analysis combines this entire family into one formulation so that the user has only to change the parameters to modify the type of projection. It indicates that any circular zone on the earth projects into a conic section in any projection and determines the location and dimensions of this conic section. Thus, a given radar site visibility zone will project, say, into an ellipse.

The technique developed provides the capability for a general projection formulation. This is being programmed for the IBM 7030 computer and the Benson-Lehner plotter to produce maps and grids in any of the perspective projections to any desired scale.

APPROXIMATION THEORY

Physical data, such as the position of a satellite or other object, cannot be obtained without error. Therefore, results of predicted positions derived from these data are also subject to error.

Estimation of these errors is an important part of any analysis of either observed data or of systems using such data. Frequently, especially for smoothing data or for short-range predictions, the

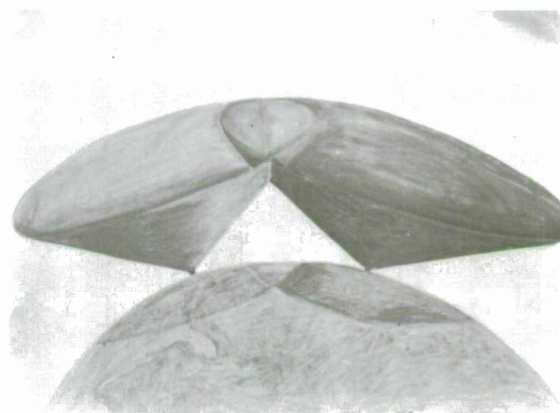

Sketch showing the approximate cones of visibility of transmitting and receiving stations in a satellite communications system.

exact functions governing the motion of the object can be approximated by functions, such as polynomials or trigonometric series, which can be calculated simpler and faster. The error resulting from this approximation can be calculated and kept under control. However, the influence of other observational errors on the results obtained from the approximating function must be determined.

The special but practically important case, where the observations are made at equal time intervals and are subject to independent random errors, has been studied. Rough estimates for the influence of this error in the case of many observations are known. Our studies gave precise estimates for the error in the case of few observations. These estimates are considerably better than those previously known.

Estimates were made for three important special cases: the midpoint of the given series of observations which is often used for more precise orbital calculations; the endpoint which is used for tracking; and for the extrapolated position which is predicted from this data.

Often polynomial or trigonometric approximations are used to obtain derivatives, such as velocity and acceleration, of the observed functions. These derivatives are highly sensitive to errors in the observed values. Precise analytic estimates for the errors could not be obtained, but approximations for large numbers of observations were found. The analytical expressions are somewhat complicated, but it was determined that the errors of the first and second derivatives at the endpoint of the series of observations increases with the third and fifth order, respectively, of the degree of the approximation.

In order to derive estimates for the practical case of few observations, numerical calculations of the errors of the derivatives for different values of some parameters were made. In addition to providing exact information about the errors in the special cases considered, they give an idea of the "goodness" of the analytical approximation described.

MATHEMATICAL PROGRAMMING

The problem of mathematical programming is to maximize or minimize a certain objective which has to be expressed as a function of controllable variables—variables subject to precisely stated constraints. Such problems arise in logistics, industrial and economic operations, and in weapons allocation problems. Though these problems may have very specific individual properties and may appear quite dissimilar, they all share a fairly singular mathematical structure. Studies of the abstract mathematical programming model can, therefore, contribute to the solution of a wide range of practical problems.

For special cases, such as linear and convex programming, good solution methods are known. Certain nonlinear and nonconvex programming problems were studied in which the objective function contains ratios of inverses of linear function. For the simplest case, methods reducing such problems to linear problems are known. Basically, the methods use the fact that one can find an optimum solution by stepwise improvement of a known solution.

We used another approach utilizing parametric linear programming procedures. This allows us to attack the more complicated problems where it is no longer true that one can find the optimum solution by stepwise improvement of the known one. Problems with this property have not been solvable, with one exception, until now.

The mathematical treatment of a programming problem requires that the objectives of the system under consideration be expressible by *one* well-defined objective function. In many practical applications this function is not given and cannot easily be found. Frequently, however, practical experience about decisions based on judgment or intuition, which are considered as "good" can be utilized. This information may be useful for deriving an objective function or for direct incorporation into a programming technique. This is currently being studied.

A special case, the allocation of resources for geographically separated contingencies, was stud-

ied. Resource requirements are assumed to be known from contingency plans. It was also assumed that, from political and military considerations, the relative importance of the contingencies is known. This can be expressed by a slightly modified priority scale which indicates in what order and to what extent resources are to be allocated to the different contingencies. The problem is: where to store resources for optimum preparation against all anticipated contingencies, and, in the case of a contingency, where to withdraw the necessary resources without unduly degrading the system against other still potential contingencies.

This problem can, under simplifying but still realistic assumptions, be formulated as a linear programming problem. It has a very special structure in that it consists of many relatively small subproblems which are only weakly linked together. This type of problem can be solved by the decomposition method of Dantzig and Wolfe. This method allows a decentralized implementation: subproblems, corresponding to individual contingency plans, can be optimized independently, and only one larger central distribution problem has to be solved. Relatively little flow of information and feedback between the different types of problems is necessary. This coupling is accomplished by means of "shadow prices" which allow determination of either an overall optimum solution by a continuous adaptation and improvement process, or, if necessary, a quick and "probably optimum" modification of the present solution. The very special features of this model permits the Dantzig-Wolfe algorithm to be further simplified.

GRAPH THEORY

Algebraic topology, a new and rapidly growing branch of pure mathematics, provides a purely algebraic expression, called the node-arc incidence matrix, to represent any graph. A graph consists of a set of junction nodes, n , and arcs (branches), a , connecting each pair of these nodes. Initial and terminal nodes of all arcs can be specified, in a

matrix form, B , where each entry is given by:

+1, if node n is the initial node of arc a ,
 -1, if node n is the terminal node of arc a ,

and

zero, if node n is not connected to arc a .

The matrix, B , completely determines the configuration of the graph. Any graph can be expressed by such an incidence matrix.

The application of incidence matrices provides a powerful mathematical tool for designing circuits. If a set of practical circuit requirements are specified, a matrix equation can be formed with the incidence matrix as the unknown quantity.

The solution of this matrix equation provides the design of the desired circuit without presuming any special connections such as series-parallel, bridge or ladder types. By a rigorous application of this method, all minimal switching two-terminal networks of three Boolean variables were obtained. The solution process proves the minimality of the circuits obtained and the non-existence of other possible minimal circuits. The results are applicable to cryogenic and relay circuits. These minimal circuits are of practical importance in reducing the weight, volume, cost, etc., of electronic systems.

Based on the incidence matrices, a new linear algebraic method of finding minimal paths and all paths between two given points in any given oriented or nonoriented graph was also established and briefly delineated.

In topological network analysis, determination of all trees of any given graph plays an important role. A procedure for determining such trees by matrix multiplication only was achieved. Its basic logic is as follows: by applying a combinatorial solution of simultaneous linear homogeneous equations to the node-arc incidence matrix, a matrix whose rows represent closed paths is obtained. Each entry of this matrix indicates whether or not the corresponding minor of the original incidence matrix represents a tree. If the notion of linear dependency is applied to this matrix, all trees and tree minors with signs are obtained for the given graph.

By attaching a unit matrix either before or after any rectangular matrix, the above technique results in a purely matrix multiplication method of evaluating all minors of all orders.

A FAST MULTIPLIER

Parallel operations have been used extensively in computers to provide a substantial reduction in processing time. The increase in components required for this goal is becoming economically more feasible through the availability of such techniques as integrated circuits and microminiaturization.

A method has been devised for increasing the speed of a computer multiplier that makes use of an ancient technique known as "Napier's Bones." This technique has been generalized and combined with the geometry of N-dimensional affine space to provide for the multiplication of n numbers. Each factor in the product can be represented by one of a set of hyperplanes in N-dimensional space.

For N factors, an N-dimensional hypercube, constructed of logical elements or modules, is sufficient to realize the diagonal hyperplane that contains the products of corresponding digits. By entering all digits of all factors, the multiplication is performed in a single logical step. Then, by sym-



The Bar Multiplier, being demonstrated here by MITRE mathematicians, is a simplified device to exemplify certain principles of parallel operations in high-speed multiplication.

metric circuits, the addition of all products of the same digits, including the carries, can be performed without a series of carry operations. Finally, these sums provide the final value of the product.

In the calculation of numerical power series with different coefficients in each term, a single hypercube can simultaneously produce all the products in each term in a single step. Hence, by adding combinations of products in this hypercube, the sum of the terms can be obtained in a few logical steps. By repeating this process, a power series of any order can be calculated.

The logical element required to implement these processes can consist of solid-state or superconductive elements such as transistors, tunnel diodes, or cryotrons.

DOCUMENTATION

Joksch, H. C. *Estimation of Variance in Fitting Curves by Trigonometric Approximations*, TM-04070, The MITRE Corp., August 1964 (Unclassified).

Joksch, H. C. *Programming with Fractional Linear Objective Functions*, presented at Joint CIRSORS Meeting in Canada, May, 1964; accepted by *Naval Logistics Quarterly*; see also TM-04072, The MITRE Corp., August 1964 (Unclassified).

Joksch, H. C. and Liss, D. *The Minimum Number of Linear Decision Functions to Implement a Decision Process*, ESD-TDR-64-171, December 1964 (Unclassified).

Joksch, H. C. *The Reduction of the Variance by Least Squares Polynomial Approximations*, accepted by *SIAM Review*; see also ESD-TDR-64-117, in press (Unclassified).

Joksch, H. C. *The Variance of First and Second Derivatives of Least Squares Approximating Polynomials*, TM-04109, The MITRE Corp., October 1964 (Unclassified).

Mannos, M., Forest, B. and Greene, R. *A Deterministic Approach to Systems of Communication Satellites*, presented at 7th MIL-E-CON, September 1963; see also ESD-TDR-63-469 (Unclassified).

Mannos, M. and Maitra, K. K. *Trajectory Estimation and Error Analysis Tristatic Tracking System*, TM-04084, The MITRE Corp., October 1964 (Unclassified).

Okada, S. *Bar-Multiplier and Its Generalization*, ESD-TDR-64-172, in press (Unclassified).

Okada, S., Liss, D. and Kolker, R. *Algebraic Techniques of Path Finding and Minimum Path Finding in Graphs*, ESD-TDR-63-179, June 1963 (Unclassified).

Okada, S. and Liss, D. *Complete List of Minimal Two-Terminal Switching Circuits of Three Variables*, ESD-TDR-62-332, November 1962 (Unclassified).

DOCUMENT CONTROL DATA - R&D

(Security classification of title, body of abstract and indexing annotation must be entered when the overall report is classified)

1 ORIGINATING ACTIVITY <i>(Corporate author)</i> The MITRE Corporation Bedford, Massachusetts		2a. REPORT SECURITY CLASSIFICATION Unclassified	
		2b. GROUP	
3 REPORT TITLE Research & Experimentation. 1960-1964			
4 DESCRIPTIVE NOTES <i>(Type of report and inclusive dates)</i> N/A			
5 AUTHOR(S) <i>(Last name, first name, initial)</i> The MITRE Corporation			
6 REPORT DATE January 1966		7a. TOTAL NO. OF PAGES 112	7b. NO. OF REFS 165
8a. CONTRACT OR GRANT NO. AF19(628)-2390		9a. ORIGINATOR'S REPORT NUMBER(S) ESD-TR-65-407	
b. PROJECT NO. AF33(600)-39852			
c. N/A		9b. OTHER REPORT NO(S) <i>(Any other numbers that may be assigned this report)</i> M65-1A	
d.			
10. AVAILABILITY/LIMITATION NOTICES Distribution of this document is unlimited.			
11. SUPPLEMENTARY NOTES N/A		12. SPONSORING MILITARY ACTIVITY Deputy for Engineering and Technology Electronic Systems Division L. G. Hanscom Field Bedford, Massachusetts	
13. ABSTRACT Document contains somewhat condensed descriptions of significant research and experimentation programs at MITRE from 1960 through 1964. Some of the technical work reported results from direct support of systems engineering or systems planning projects, and some relates to research expected to have a broad application to existing problems or to the advancement of science and technology. Many of the latter efforts were performed under the MITRE Independent Research Program. While it is not intended to be a complete report of MITRE research and experimentation, the document does cover major projects with sufficient technical depth to give the reader an appreciation of the scope, complexity and value of each effort. The 165 references cited throughout the document provide detailed discussions of some of the technical areas highlighted.			

14. Key Words

RESEARCH AND EXPERIMENTATION

Sensor Systems

Radar Sensors

Sensors for Nuclear Detection

Optical Technology

Communications Systems

Digital Data Transmission

Optimum Modulation Techniques

Flexible Error-Correcting Coder-Decoder

Network Survivability

Environmental Factors

Tropospheric Propagation

Line Integral Refractometer

Flame Plasma

Computer Technology

Display

Three-Dimensional

Digital Computer, General Purpose (Phoenix)

Systems Design Laboratory

Hardware

Software

Information Processing Techniques

Data Management Systems

Processing Techniques

Retrieval Systems

Information Transfer

Natural Language Processing Techniques

Information Display

System Studies

Command Planning

On-Line Control Techniques (AESOP) for Operational Planning

Life Support

Mathematics

Command and Control Systems, Aerospace Communications

Trajectory Estimation and Error Analysis

Perspective Projections

Approximation Theory, for Predicting Position Errors

Graph Theory, Application to Circuit Design

Fast Multiplier Techniques

