

AD626831

Technical Note N-756

BLAST RESISTANCE OF CHECK AND GATE VALVES

By

K. R. Bockman, J. C. King and R. S. Chapler

November 1965

Code 1

CLEARINGHOUSE FOR FEDERAL EXPERIMENTAL AND TECHNICAL INFORMATION		
Hardcopy	Microfilm	
\$2.00	\$0.50	32.70
ARCHIVE COPY		

DDC
RECEIVED
JAN 28 1966
DDC-IRA B

U. S. NAVAL CIVIL ENGINEERING LABORATORY
Port Hueneme, California

20050307004

BLAST RESISTANCE OF CHECK AND GATE VALVES

Y-F011-05-02-347

Type C

by

K. R. Bockman, J. C. King and R. S. Chapler.

ABSTRACT

The objective of this task was to determine the blast resistance of standard check and gate valves which may be used in protective shelter equipment and utility systems. To accomplish this objective, commercially available 3 inch 200 psi WOG (water, oil, or gas) bronze check and gate valves were subjected to transient air pressures to about 390 psi (the maximum capability of the Laboratory at the time of the tests) and to transient hydraulic pressures to about 2000 psi. Subsequent visual examination, operational tests, and hydrostatic leak tests revealed no damage to the valves, and test data indicated relatively low magnitudes of strain, which leads to the conclusion that standard check and gate valves can withstand transient loads far in excess of their rated capacity.

In order to determine whether or not the valves may be dynamically loaded when subjected to a nuclear blast wave, the natural frequencies of the valves were obtained and compared to the rise time of nuclear explosions. This showed that if a blast wave reaches the valve without attenuation, dynamic loading could occur. If, however, the wave must propagate through a piping system to reach the valve, the wave front may be relatively unchanged, or it may steepen and possibly increase the dynamic loading, or it may be attenuated so that little or no dynamic loading would occur. In the case of shocks generated by the test equipment, it was shown that dynamic loading was not applied. Because the most severe loading conditions could not be produced by the test equipment, the exact configuration in which valves are to be used must be considered before recommendations can be made as to their blast resistance.

Qualified requesters may obtain copies of this report from DDC.
Release to the Clearinghouse is authorized.

Preceding Page Blank

INTRODUCTION

The objective of this task was to determine the blast resistance of standard check and gate valves which may be used in protective shelter equipment and utility systems. Test shock pressures up to the maximum capability of the Laboratory or 1000 psi were specified¹. Test pressures were generated in air and in water because some valves in shelter equipment are open to the atmosphere and could receive air blast loading from a nuclear explosion. Other valves are connected to fluid lines which are open to the atmosphere and they could receive blast loading through the fluid.

Commercially available valves were tested with (a) transient air pressures in the NCEL Blast Simulator and (b) transient hydraulic pressures in a testing device designed for this task. To analyze the response of the valves to the test loads, the natural periods of vibration of the test valves were obtained by means of an NCEL materials tester. To determine the response of the valves to nuclear blast waves, studies were conducted regarding the nature of the wave that would reach the valve.

Scope of the experimental investigation was limited to testing the resistance of utility valves to the shock loads that could be produced with NCEL equipment. Visual examination, operational tests, and leak tests were conducted to determine whether the valves had been damaged by the test loads.

THEORY

Atmospheric Blast Waves

The pressure effects of the blast wave produced by a nuclear explosion are characterized by a sharp rise to maximum pressure, decay through a positive overpressure phase which may last for several seconds, and recovery through a prolonged negative phase.^{2,3,4} The passage of a high-pressure blast wave in the atmosphere is accompanied by a transient high-velocity wind. This wind produces the so-called "dynamic pressure" which gives a drag effect on a structure and which contributes to the intensity of the pressure wave reflected from an obstacle in the path of the blast wave.

The nature of the atmospheric blast wave depends on a number of factors including the size (yield) of the weapon, altitude of the explosion, and distance from ground zero. In this report, data is used from Reference 3 relating to a one-megaton surface explosion. A peak overpressure of 1,000 psi is experienced at a distance of 1,500 feet from ground zero, the shock wave arrives 0.070 seconds after the burst, and the duration of the positive overpressure stage of the blast wave is 1.2 seconds. The variation with time of the overpressure is approximated by the equation

$$\Delta P = 1000(0.15e^{-2.90\gamma} + 0.30e^{-21\gamma} + 0.55e^{-130\gamma})(1-\gamma)$$

where

$$\gamma = \frac{t}{1.2}$$

and time is measured from the incidence of the blast wave peak.*

A reflected pressure wave is produced whenever the blast wave encounters an obstacle or discontinuity. The pressure exerted on the obstacle is that of the reflected wave. The pressure due to the reflection of a shock wave hitting a wall head-on in a perfect gas is given by the equation⁵

$$P_r = 2P + \frac{(\gamma+1)P^2}{2\gamma P_o + (\gamma-1)P}$$

where

P = the incident overpressure

P_o = the initial ambient pressure.

γ = the ratio of specific heats of the gas.

*These and other data from Reference 3 are the result of theoretical analysis and may not agree exactly with the measured results of any particular test.

At overpressures beyond several atmospheres there is sufficient variation of the ratio γ , due to increased temperature behind the shock wave, that this equation becomes inaccurate for predicting the pressure of a reflected shock wave in air. Figure 1, from Reference 3, shows how the ratio of reflected pressure to incident pressure varies as a function of the incident shock pressure in air at sea level.

Blast Wave Propagation in Conduits

The propagation of blast waves in conduits or tunnels affects the equipment for protective shelters as well as the equipment for blast testing. The characteristics of the transmitted blast wave are affected not only by the properties of the medium through which the wave propagates but also by the geometry and length of the conduit and by the conditions at the ends of the conduit. Conduit geometry, combined with the pressure history at the exposed end of the conduit, can increase or decrease the severity of the blast effects at the closed end of the conduit.^{6,7}

Comparison of Shock Reflection in Air and in Water

Hydraulic pressure waves with levels of intensity of interest in this task can generally be treated as acoustic waves; the pressure of a normally reflected wave is only slightly greater than twice the pressure of the incident wave.⁸ This difference in the shock reflection phenomena in water and in air is due to the relatively high density and low compressibility of water. At such moderate pressures there is little motion of the water through which the wave propagates, and there is correspondingly little "dynamic pressure" effect.

The relative effectiveness of shocks in air to shocks in water, in terms of peak reflected pressure, is just equal to one half of the reflection factor ($\frac{\text{reflected overpressure}}{\text{incident overpressure}}$) for the shocks in air. The maximum pressure due to reflection of a 1,000-psi shock in air at sea level is about equal to the pressure due to the reflection of a 4,000-psi shock in water.

Dynamic Response of an Elastic System

Dynamic response will be discussed, for simplicity, in terms of the response of a simple mechanical system consisting of a mass restrained by a linear spring. Some caution must be exercised in extending the results of such simplified analysis to the prediction of the behavior of a multi-degree-of-freedom system such as the disc of a utility valve, but it can be expected that the response of the disc to pressure disturbances will be dominated by vibration in the mode corresponding to the lowest natural frequency. It is possible, however,

for dynamic load effects to be more severe in continuous elastic systems than they would be in the one-degree-of-freedom model.⁹ There is a report on this subject scheduled for publication in 1965.¹⁰

Figure 2 is a spectrum¹¹ of the response of a simple mechanical system to shocks of the form

$$F(t) = \begin{cases} F_0 \frac{t}{t_1} & , 0 \leq t \leq t_1 \\ F_0 \left(1 - \frac{t-t_1}{t_2}\right) e^{-a(t-t_1)} & , t_1 \leq t \end{cases}$$

for time parameters on the order of those which would be valid for nuclear blast loading of the utility valves tested. Figure 2 shows the effect that rise time (t_1) of the shock has on the maximum displacement of the system. It may be observed that this is not much different than the spectrum for shocks of the form¹²

$$F(t) = \begin{cases} F_0 \frac{t}{t_1} & , 0 \leq t \leq t_1 \\ F_0 & , t_1 \leq t. \end{cases}$$

The derivation of the equation of the spectrum in Figure 2 is given in Reference 13. An exact solution is obtained for the equation of motion, this is simplified by the provision that t_1/t_2 , a/p ,* and $1/pt_2$ are all very small, and the maximum displacement is obtained as a function of the ratio of rise time to the natural period of the system. The precise nature of the spectrum might be quite different for cases in which the above approximations are not valid.

It can be seen from the simplified equation of motion that the maximum displacement occurs within the first cycle of oscillation after the load reaches its maximum value. Thus the maximum elastic response of the system is independent of the manner in which the load decays after that time. However, if permanent damage is done to the system, its response will be inelastic and will depend upon the time profile of the pulse.

*Here "p" is 2π times the natural frequency of vibration of the system.

TEST VALVES

A number of commercially available check and gate valves were obtained for testing. The sizes of valves ranged from 3 to 8 inches and the valve working pressure ratings ranged from 200 to 600 psi WOG (water, oil and gas). A description of the valves is given in Table I. It may be noted that the gate valves have three different stem and disc combinations: solid disc with rising stem, double disc with rising stem and solid disc with non-rising stem. These are shown in Figures 3, 4 and 5. A check valve is shown in Figure 6.

NATURAL FREQUENCY TESTS

Description of Tests

The natural frequencies of vibration of the valves were obtained on an NCEL materials tester. The materials tester functions by inducing vibrations with an electromagnetic driver which can be regulated from 20 to 20,000 cycles per second with a variable frequency oscillator and which can be applied directly to the specimen. Response of the specimen is measured by an accelerometer whose output is read on an oscilloscope. Critical frequencies of the specimen are obtained by adjusting the driving frequency for maximum response. The frequency is indicated by a decade counter which is connected to the oscillator.

Frequencies of the valve discs were measured with the driver and accelerometer applied at the centers of the discs. Readings were also taken with the driver applied at various places on the valve bodies. A photograph of the test set-up for one of the valves is shown in Figure 7. The electromagnetic driver is mounted on the arm of the device and the accelerometer is shown attached to the valve disc. The oscilloscope, the counter, and the frequency control dial are also shown in the photograph.

Results

The natural frequencies of vibration of the valve discs are listed in Table II. The calculated periods of the discs are also shown. It may be noted that all of the 3-inch solid discs had periods of about 0.1 millisecond (ms). The 3-inch double discs vibrated somewhat more slowly, with periods of about 0.12 ms. The larger gate valves had increasingly longer periods of vibration with a range of 0.178 ms for a 4-inch valve, to 0.294 ms for the 8-inch valve. The 3-inch check valves had periods from 0.145 to 0.204 ms, and the 4-inch check valve had a period of 0.270 ms. The check valve discs had longer periods than gate valve discs of comparable size and rating. The frequencies

of the valve bodies varied considerably with different locations of the electromagnetic driver, and their frequencies were in all cases higher than the valve disc frequencies. In Table II, only the valve disc frequencies are listed; the valve body frequencies are omitted because of the differences in readings obtained with different positioning of the electromagnetic driver.

AIR BLAST TESTS

Description of Test Set-Up

The NCEL Blast Simulator was used to conduct the air blast tests. A schematic drawing of the test set-up is in Figure 8. Pressures were generated by using primacord explosive which was ignited simultaneously at each end of the 20 foot long firing tube. The primacord charges were regulated to generate pressures of 83, 115, and 147 psi within the blast simulator skirts. The 147 psi charge was not large enough to satisfy the task requirements but it was considered the largest that could be safely applied to this set-up.

Pressure at the valve was measured by a transducer which was installed in the 4-inch long section of pipe that connects the valve to the Blast Simulator. Strain in the valve discs was determined by three strain gages which were connected to the downstream side of each disc. Leads from the pressure transducer and the strain gages were connected through amplifiers to a direct-writing oscillograph.

Results

Test valve No. 1, a 3" 200 psi WOG solid disc gate valve was tested at overpressures of 83, 115, and 147 psi. A pressure trace of the 147 psi shot as indicated by the transducer in the pipe is shown in Figure 9. The high pressure spike at the front of the wave is assumed to be due to reflected pressure in the adapter.

A visual examination which was made after each shot did not reveal any damage to the valve. After the 147 psi shot, the valve was opened and closed several times with no signs of operational difficulty. It was then subjected to a 200 psi hydrostatic test and again there were no leaks. The strain of the valve disc at the peak pressure of each of the three shots is shown in Figure 10.

Valve No. 5, a 3" 200 psi WOG double disc gate valve, and valve No. 14, a 3" 200 psi WOG check valve, were next tested. The pressure traces were quite similar to the one in Figure 9. Visual examination, operational tests and leak tests did not reveal that any damage was done to the valves. Strain versus pressure of these valve discs are plotted in Figures 11 and 12.

Comparison of data for the three valves shows that at maximum loading the solid disc had the least measured strain with about 150 microinches per inch (μ in./in.). The double disc had the next least strain with about 200 μ in./in., and the check valve disc had the most strain with about 950 μ in./in.

HYDRAULIC TESTS

Description of Test Set-Up

A device called the Blast Load Simulator for Utility Valves (BLSUV), developed under this task, was used for all of the hydraulic tests. A schematic drawing of the device is shown in Figure 13. Pressures were generated in a water-filled 3" steel pipe by a weight falling on the plunger of a hydraulic cylinder. Pressures thus generated were transmitted to the valve through the fluid in the cylinder. The first fluid used was hydraulic oil, but this was subsequently changed to a mixture of water and water soluble oil. The ratio of water to oil was continuously increased until finally all water and no oil was used. It was found that faster rise times could be obtained when water by itself was used. The BLSUV test set-up is shown in Figure 13.

The main frame of the device consists of the base (1), the upright columns (2), the yoke (3), supports (4) and hydraulic cylinder (5). The elevator table (6) is guided by the columns and can be raised and held at any preselected height by the lifting cord (7) which is attached to the winch (8). When the electrically activated cord release mechanism (9) is energized by the switch (10), the table will drop.

The hydraulic cylinder assembly consists of the plunger (11), a removable threaded cap (12), a hydraulic hand pump (13) for static-preloading, a pressure gage (14) for measuring the preload, and a pressure cell (15) for indicating the impulse pressure profiles. The valve to be tested (16) is threaded to the bottom end of the cylinder.

A typical sequence of operations for the BLSUV is as follows:

1. A test valve is threaded to the bottom of the cylinder.
2. The cylinder is filled with fluid and purged of air. The filling can be accomplished by using the hydraulic pump or by removing the threaded cap and pouring the fluid into the cylinder.

3. The desired amount of preload (200 psi) is obtained by use of the hydraulic pump. Upward plunger travel is stopped by the cap when the cylinder is pressurized.
4. The total required weight of the elevator table for a test is obtained by attaching additional weights as required to the lower arm of the elevator table.
5. The elevator table is raised to the desired drop height by hand turning the winch. A ratchet on the winch holds the table at any desired height.
6. A drop is effected electrically when the cord release mechanism is actuated.
7. A pressure-time profile of the impulse from the drop is recorded by a direct writing oscillograph which is connected through amplifiers to the pressure cell.

Description of Tests

A trace of a typical 1000 psi pressure pulse is shown in Figure 14. This trace was obtained with a 20-lb weight and a 20-inch drop height. This impulse was not considered satisfactory because it did not have the duration of sustaining force of the blast wave produced by a nuclear explosion. The problem was subsequently solved by connecting 20-foot lengths of 3-inch-diameter pipe between the cylinder and the valve and by increasing the weight to compensate for the extra volume of fluid; thus a pressure wave developed with a somewhat steeper front and a much longer duration. It was found that a pressure profile which had the fastest rise time (0.4 ms) and also had the best resemblance to a nuclear explosion profile was obtained when 100 feet of pipe was used. A trace of a typical pulse indicated by a pressure cell placed at the valve is shown in Figure 15. For purposes of comparison, a trace of the same pulse at the beginning of the pipe is shown in Figure 16. These traces were obtained by dropping 300 pounds a distance of 20 inches and the maximum pressure thus obtained at the valves was about 1200 psi.

Impulse loadings were later increased to subject the valves to peak pressures of about 2000 psi. This was accomplished by reducing the length of pipe to 20 feet and increasing the drop height to 48 inches. With this arrangement, pressures of over 2000 psi at the valve were obtained and the rise times were about 0.8 ms. A trace of a pressure profile at the end of the 20-foot length of pipe, when a 300-pound weight with a 48-inch drop height was used, is shown in Figure 17. All of the profiles generated would repeat many times with decreasing amplitude before completely decaying.

Hydrostatic leak tests were conducted by pressurizing the water line of the BLSUV to 200 psi with the hand pump. Strain gage readings were also taken at this static pressure.

Results

Test valves Nos. 1, 5, and 14, which were previously tested on the Blast Simulator, were subjected to increasing increments of loads up to about 1200 psi. The pressure pulses generated are similar to that shown in Figure 15. Visual examination, operational tests, and 200 psi hydrostatic tests did not reveal that any damage was sustained by the valves.

BLSUV modifications were made in order to generate 2000 psi peak pressures, and the previously tested valves were subjected with increasing increments of load to the type of impulse shown in Figure 17. The maximum load was applied at least five times to each valve. The valves did not fail and the subsequent visual inspection, operational tests, and hydrostatic leak tests did not reveal any damage. A fine spray of water leaked from around the bonnet of the check valve at pressures over about 1600 psi, but the leak stopped as soon as the pressure was relieved. Since none of these valves were damaged, no further tests were conducted on the remaining valves.

Negative pressure caused by reflections would occasionally occur in line and cause the disc of the check valve to open. Air would then enter the line, and it would be necessary to bleed the system before the other tests on the valve could be conducted. For this reason, the disc was held closed with contact cement during the continuing tests.

The strain gage data for the BLSUV tests are, for purposes of comparison, shown with strain gage data from the Blast Simulator tests in Figures 10, 11, and 12. The pattern of results of the hydraulic tests is similar to the pattern of results of the air blast tests in that the solid disc had the least amount of strain and the check valve disc had the greatest amount of strain. The check valve disc was strained to such an extent that the strain gages were damaged at pressures over 480 psi; therefore, no data beyond this point could be taken for that valve.

At 480 psi, the disc of the check valve had a strain of about 1200 μ in/in. whereas the strain of the gate valve discs at this pressure was about 100 μ in/in. At 2000 psi, the double disc had a strain of 800 μ in/in., which was about ten times the working pressure strain. The solid disc at 2000 psi had a strain of 500 μ in/in., which was also about ten times the working pressure strain.

It may be noted that strain versus pressure data for the solid disc and for the check valve disc plotted as a straight line. Strain data of the double disc also plotted as a straight line above 1000 psi but at lower pressures the data plotted as a curve. This was probably caused by the complicated dynamics of the double disc. Apparently the downstream half of the disc was partially isolated from upstream pressure shocks below 1000 psi.

DISCUSSION OF RESULTS

Evaluation of Utility Valves

Rise times of the shocks generated by the test equipment were long in comparison to the natural periods of the test valves. The fastest rise times obtained were about one millisecond for the Blast Simulator tests and about one-half millisecond for the BLSUV tests; the periods of the 3-inch valves are about 0.1 millisecond. For maximum response to occur (Figure 2), which is when the rise time is equal to or less than one-half of the period of the valves, a rise time no longer than 50 microseconds is required. This indicates that for dynamic loading, the Blast Simulator rise times were too long by a factor of about 20 and the BLSUV rise times were too long by a factor of about 10.

Rise times from nuclear blast waves can be from almost zero to about 0.10 seconds.¹⁴ Information concerning how close to zero a rise time can occur could not be found, but it is known that an atmospheric blast wave produced by a nuclear explosion can be expected to have rise times shorter than 50 microseconds.* There is thus a range of rise times between almost zero and 50 microseconds that may act as a true shock front and which could cause dynamic loading, a condition not simulated by the test equipment.

The nature of the wave at the valve, however, may not always appear as an atmospheric blast wave; the final shape depends to a large extent on the location of the valve within the shelter system and the medium through which the wave propagates. If the valve location is near to the surface of the earth, the loading could appear as an atmospheric blast wave with a true shock front equal to the magnitude of the peak overpressure followed by reflected pressure considerably higher than the peak overpressure. If the blast wave must propagate through a pipeline system to reach the valve, the peak overpressure may be increased or

*Telephone conversation with Mr. W. J. Taylor, Ballistic Research Laboratories, Aberdeen Proving Ground, Maryland, August 26, 1965

decreased and the wave front may steepen and possibly increase the dynamic loading, or it may be attenuated so that little or no dynamic loading would occur. In some circumstances an instantaneous pressure rise to a magnitude of 30 to 40% of the normal peak pressure would occur, followed by a gradual pressure rise to the magnitude of the peak overpressure. The valve would thus respond dynamically to the magnitude of the instantaneous pressure rise (30 to 40% of peak overpressure for this example); the remaining pressure rise would act as static loading.

Because of the uncertainties as to the type and magnitude of loading which would be received by utility valves in shelter systems, a specific recommendation as to their resistance for a given overpressure level cannot be made. The tests conducted have shown that utility valves will withstand transient loads far in excess of their rated capacity, which would indicate that they are potentially useful for shelter applications. In order to evaluate a valve for a specific condition, the exact configuration in which the valve is to be used would have to be considered and tests of analyses performed to first determine the type of loading, and then determine resistance of the valve to this loading.

Judging from the strain gage data and from the theories of shock reflection and of dynamic response to transient loading, it must be concluded that the most severe shock applied to any of the test valves was a hydraulic shock before reflection of about 1000 psi overpressure and with rise time longer than the valve's period of free vibration. Similar dynamic response would be induced by a hydraulic wave of 500 psi overpressure with rise time shorter than one half of the period of free vibration; the corresponding pressures for air shocks at sea level, estimated on the basis of maximum reflected overpressure, would be under 200 psi for shocks with slow rise time and under 120 psi for shocks with fast rise time.

Estimation of stresses on the basis of strain gage data from the tests of the check valve, up to the failure of the strain gages, indicates that the disc of this valve must have been strained inelastically in the hydraulic tests. There seems to be no reason why the valve should not be able to sustain a limited amount of inelastic deformation without having its functioning impaired, but it is probable that at higher pressures the disc would be so deformed that it would no longer seat properly.

Test Data

The pressure transducer used in the shock tests was placed so near to the valves that it could not distinguish between the incident pressure waves and the reflected pressure waves; the times required for the waves to be reflected back to the transducer from the valves were less than the rise times of the shocks. Thus the recorded pressures include reflection effects, and they should not be interpreted as the incident shock wave pressures.

The strain gage data suggests that the pressures measured in the BLSUV tests were about the same as the pressures which were exerted on the valves; strains due to hydrostatic loading fall approximately on the same straight lines as do strains due to shock loading in Figures 10, 11, and 12. This would mean that the pressures reflected from the valves were the pressures sensed by the transducer.

Strain gage data from the Blast Simulator tests were consistently higher than the data from the BLSUV tests for the same recorded pressures; apparently the transducer was exposed to lower pressures than the valve discs in the pneumatic tests. There does not seem to be any simple explanation of why this should have happened.

FINDINGS

1. The test valves had short natural periods of vibration relative to the pressure rise times of the loading devices.
2. The 200 psi WOG bronze valves withstood without damage reflected air pressures of at least 390 psi.
3. The 200 psi WOG bronze valves withstood without damage reflected hydraulic pressures of about 2000 psi.
4. Maximum air blast test loads were equivalent to shocks in air of about 200 psi with slow rise times, and about 120 psi with fast rise times.
5. Air in the fluid line of the BLSUV would cause the pressure rise time to increase and the peak pressure to decrease.
6. Pressure fluctuations within the fluid line of the BLSUV caused the disc of the check valve to open and close.

CONCLUSIONS

1. The test equipment was not capable of subjecting the valves to the dynamic loads that could occur from a nuclear blast.
2. At any given pressure level, the check valve incurred larger strains than the other valves tested. The 3-inch check valve disc was probably deformed inelastically by the hydraulic shock tests.
3. The check valve would probably open during the suction phase of a nuclear blast wave.

RECOMMENDATIONS

It is recommended that the configuration of valves in shelter systems be obtained and tests or analysis be conducted to determine the type of loading that will reach the valve. If the loading proves to be dynamic, additional tests as follows are recommended.

1. Blast tests should be conducted with equipment that is capable of producing shock waves with rise times less than one half of the natural periods of the test valves. Equipment requirements can be eased somewhat by testing larger valves with longer natural periods.
2. Instrumentation should be used which will distinguish reflected pressures from the pressures of the incident shock waves. This may require that a series of gages be placed along the pressure tube.
3. Strain measurements should be provided with gages and mountings capable of withstanding large strains under shock loadings.
4. Means of detecting any leaks that may develop during air shock testing should be provided.

ACKNOWLEDGEMENT

Mr. D. F. Sampsell and Mr. C. L. Herndon conceived and designed the preliminary version of the BLSUV.

REFERENCES

1. Department of the Navy, Bureau of Yards and Docks. Task instructions for FY-65 NCEL Program.
2. U. S. Department of Defense. Effects of nuclear weapons, rev. ed., S. Glasstone, ed., Washington, D. C., 1962, Chapter III.
3. Rand Corporation. Report R-425-PR, A review of nuclear explosion phenomena pertinent to protective construction, by H. L. Brode, Santa Monica, California, May 1964, Chapter VII.
4. U. S. Air Force Special Weapons Center. Technical Documentary Report Number AFSWC-TDR-62-138, Principles and practices for design of hardened structures, by N. M. Newmark and J. D. Haltiwanger, Kirtland Air Force Base, New Mexico, December 1962, Chapter 3.
5. U. S. Department of Defense. Op. Cit., p. 122.
6. Army Ballistic Research Laboratories, Memorandum Report No. 1390. DASA Report No. 1273, Blast patterns in tunnels and chambers; information summary, Second Edition, by the Shock Tube Facility Staff, Aberdeen Proving Ground, Maryland, March 1962.
7. P. Lieberman. "Blast-wave propagation in hydraulic conduits," Transactions of the ASME, Series A, Journal of Engineering for Power, vol. 87, no. 1, Jan., 1965, pp. 19-28.
8. Robert H. Cole. Underwater explosions, The Princeton University Press, Princeton, New Jersey, 1948, pp. 53-57.
9. J. M. Frankland. "Effect of impact on simple elastic structures," Proceedings of the Society for Experimental Stress Analysis, vol. VI, no. 2, Addison-Wesley Press, Inc., Cambridge, Mass., 1949, pp. 7-25.
10. U. S. Air Force Weapons Laboratory. Technical Documentation Report Number TDR-63-3096, Vol. V, Response spectra of multi-degree-of-freedom elastic systems, by Newmark-Hanson and Associates, Kirtland Air Force Base, New Mexico, to be published in 1965.
11. Lydik S. Jacobsen and Robert S. Ayre. Engineering vibrations, McGraw-Hill Book Company, Inc., New York, 1958, pp. 160-161.
12. Ibid., pp. 180, 181.

13. Arthur B. Chilton. "Structural response to atomic blasts" in Studies in Atomic Defense Engineering. NAVDOCKS P-240, Revised June 1962, pp. 40-46. Department of the Navy, Bureau of Yards and Docks, Washington, D. C.

14. Nathan M. Newmark. "Designing for atomic blast protection", in Studies in Atomic Defense Engineering. NAVDOCKS P-240, Revised June 1962, p. 109. Department of the Navy, Bureau of Yards and Docks, Washington, D. C.

TABLE I. DESCRIPTION OF TEST VALVES

Valve Number	Type	Size (inches)	Pressure Rating		Type of Body	Type of Disc ¹	Type of Stem
			Steam (psi)	WOG (psi)			
1	Gate	3	125	200	Bronze	Solid	Rising
2	Gate	3	150	300	Bronze	Solid	Rising
3	Gate	3	200	400	Bronze	Solid	Rising
4	Gate	3	300	600	Bronze	Solid	Rising
5	Gate	3	125	200	Bronze	Double	Rising
6	Gate	3	150	300	Bronze	Double	Rising
7	Gate	3	200	400	Bronze	Solid	Nonrising
8	Gate	3	300	600	Bronze	Solid	Nonrising
9	Gate	3	125	200	Iron	Solid	Nonrising
10 ²	Gate	4	125	200	Iron	Solid	Nonrising
11 ²	Gate	4	125	200	Iron	Solid	Nonrising
12	Gate	6	125	200	Iron	Double	Rising
13	Gate	8	125	200	Iron	Single	Nonrising
14	Check	3	125	200	Bronze	Swing	None
15	Check	3	200	400	Bronze	Swing	None
16	Check	3	300	600	Bronze	Swing	None
17	Check	4	125	200	Iron	Swing	None

1. All Discs were made of bronze
2. These valves had different manufacturers

TABLE II. NATURAL FREQUENCIES AND NATURAL PERIODS
OF THE DISCS OF THE TEST VALVES

<u>Number</u>	<u>Type</u>	<u>Size (inches)</u>	<u>WOG Rating (psi)</u>	<u>Natural Frequency (cycles per second)</u>	<u>Period (milliseconds)</u>
1	Gate	3	200	10,300	0.097
2	Gate	3	300	10,400	0.096
3	Gate	3	400	9,800	0.102
4	Gate	3	600	9,000	0.111
5	Gate	3	200	8,200	0.122
6	Gate	3	300	8,500	0.118
7	Gate	3	400	9,600	0.104
8	Gate	3	600	9,400	0.106
9	Gate	3	200	9,800	0.102
10	Gate	4	200	5,600	0.178
11	Gate	4	200	3,400	0.294
12	Gate	6	200	3,900	0.256
13	Gate	8	200	3,400	0.294
14	Check	3	200	4,900	0.204
15	Check	3	400	6,800	0.147
16	Check	3	600	6,900	0.145
17	Check	4	200	3,700	0.270

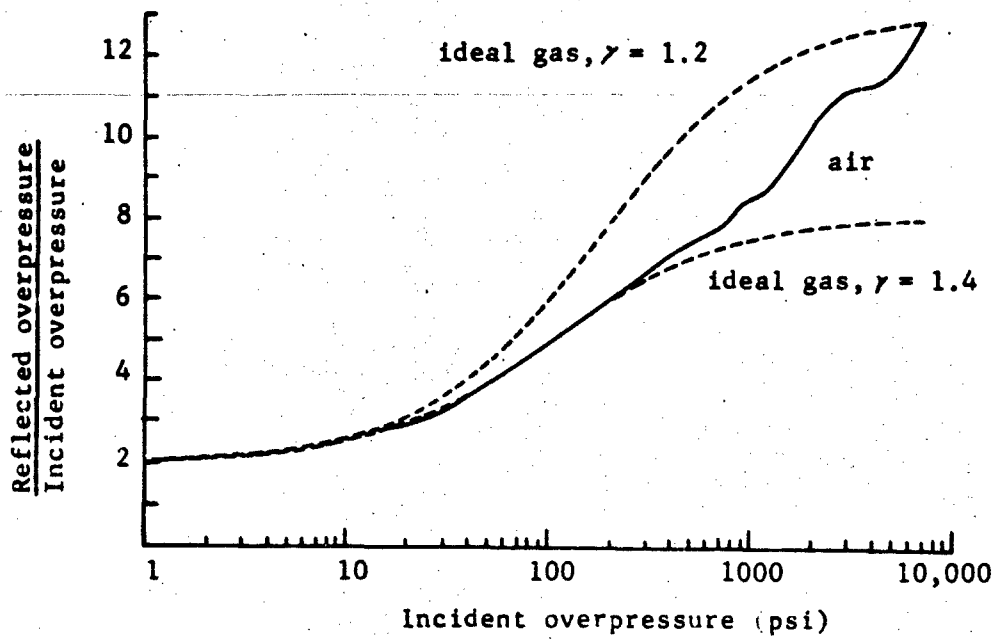

Figure 1. Reflection factors for normal shocks at sea level.

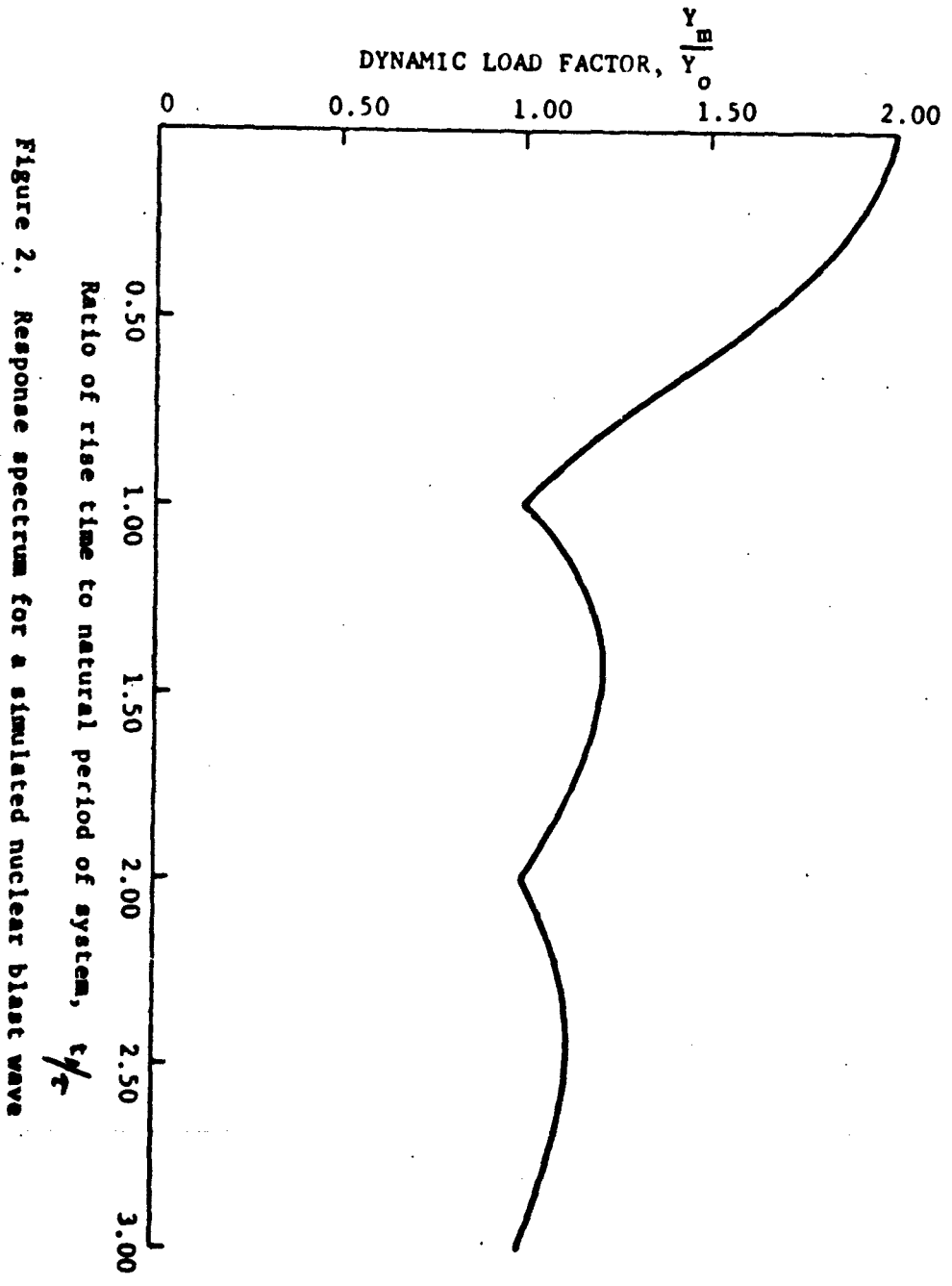

Figure 2. Response spectrum for a simulated nuclear blast wave

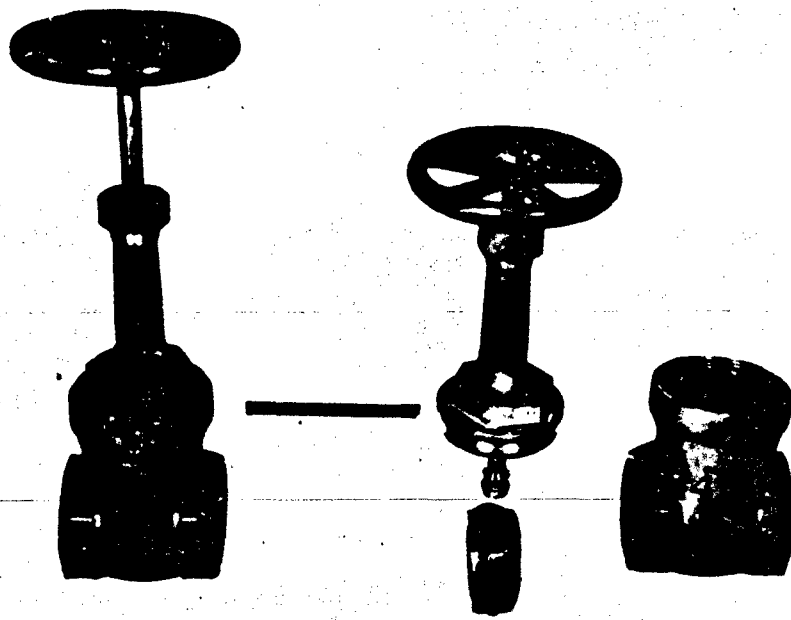

Figure 3. A solid-disc, rising stem gate valve.

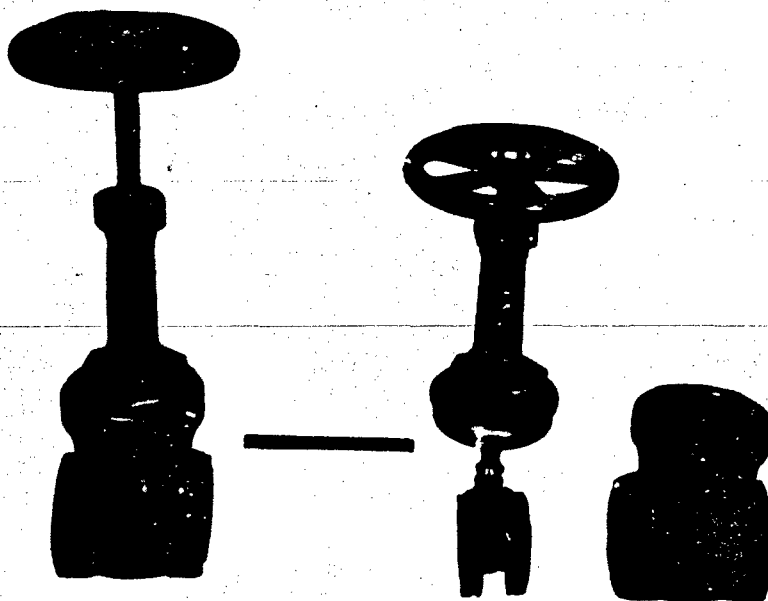

Figure 4. A double-disc, rising stem gate valve.

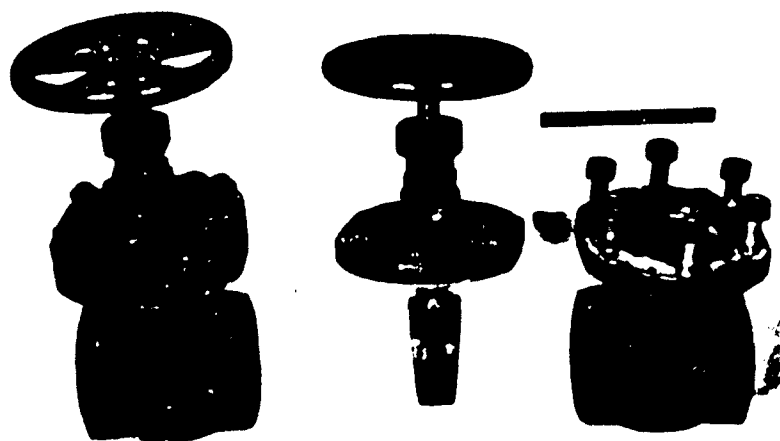

Figure 5. A solid-disc, non-rising-stem gate valve.

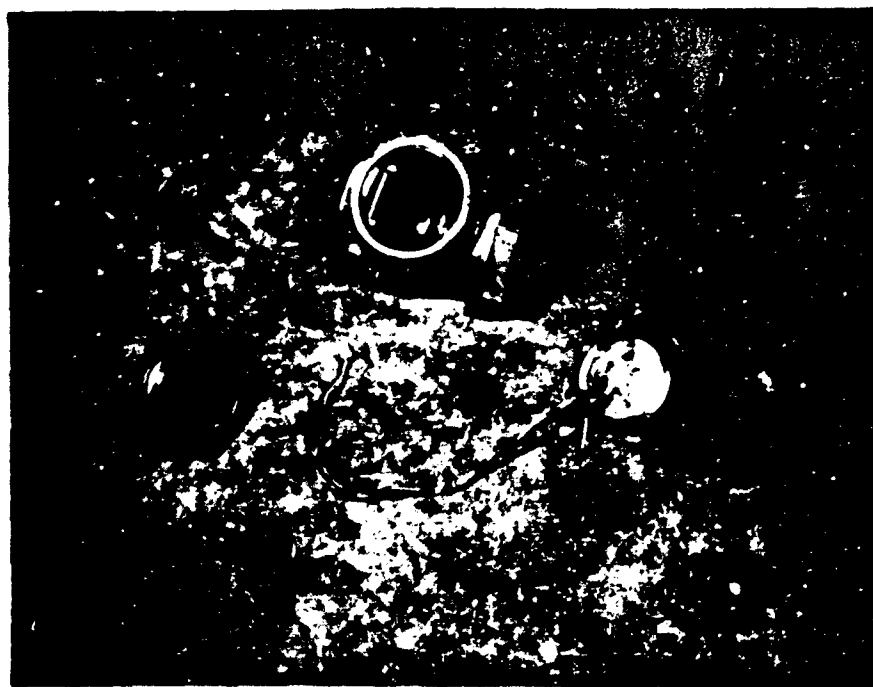

Figure 6. A horizontal-swing check valve.

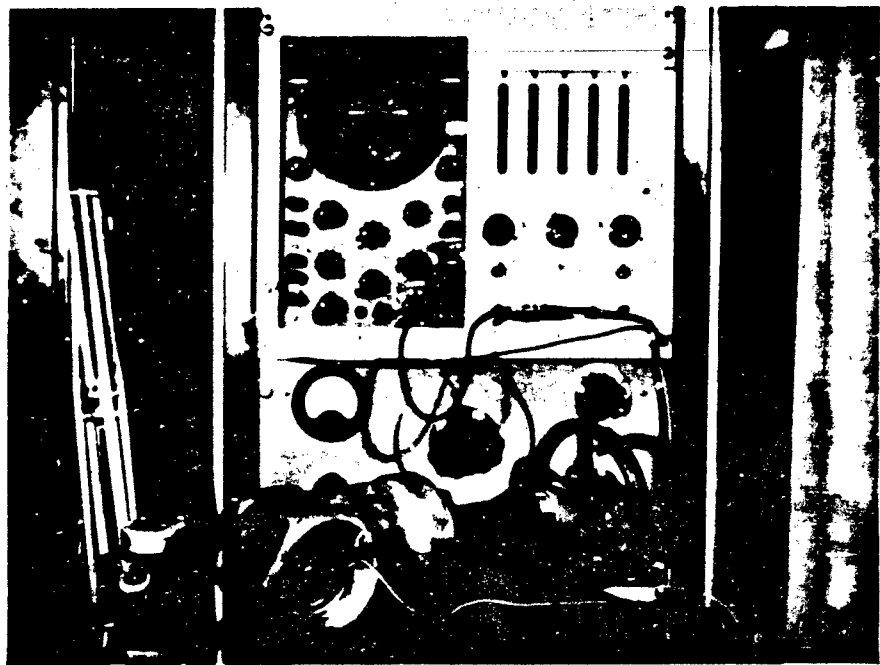
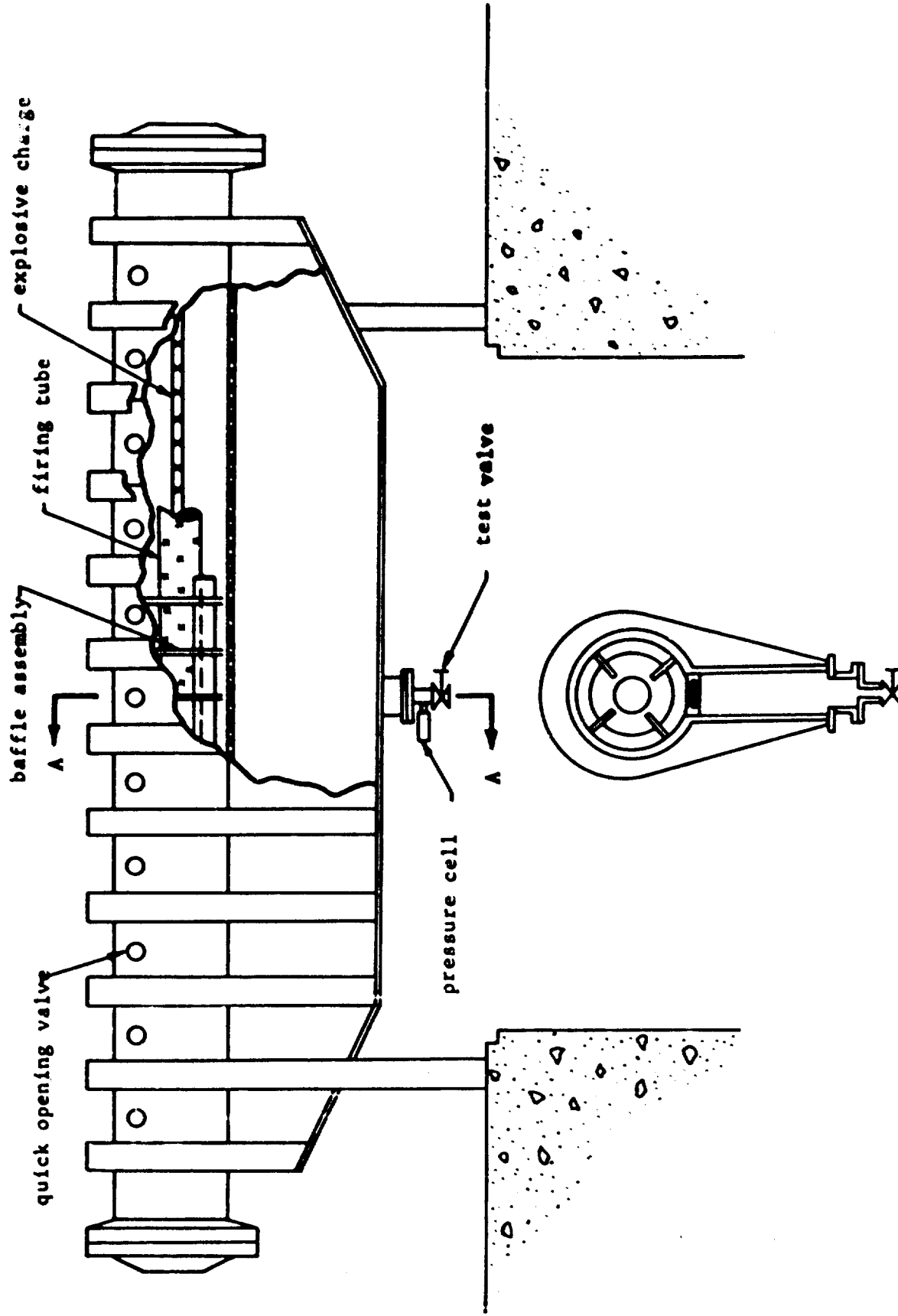

Figure 7. A gate valve ready for analysis.



Section A-A

Figure 8. Schematic drawing of a test valve on the NCEL blast simulator

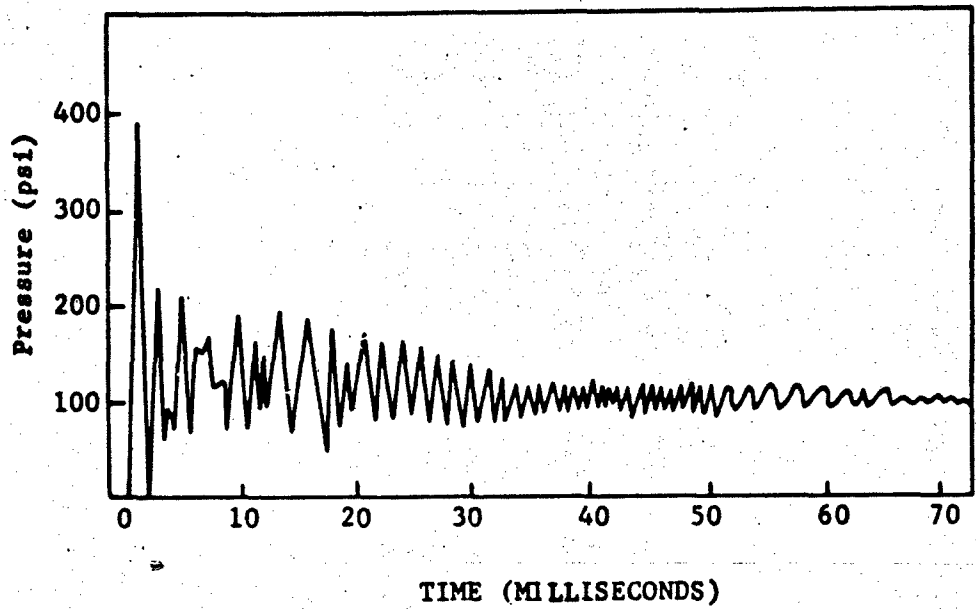

Figure 9. Typical pressure profile from the NCEL blast simulator

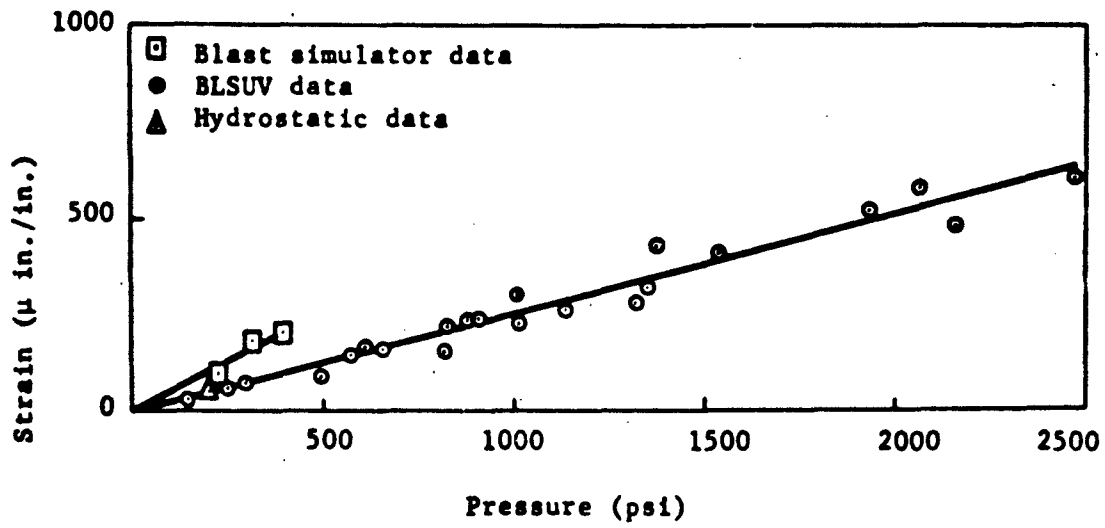

Figure 10. Strain of the disc of the 200 psi solid disc gate valve

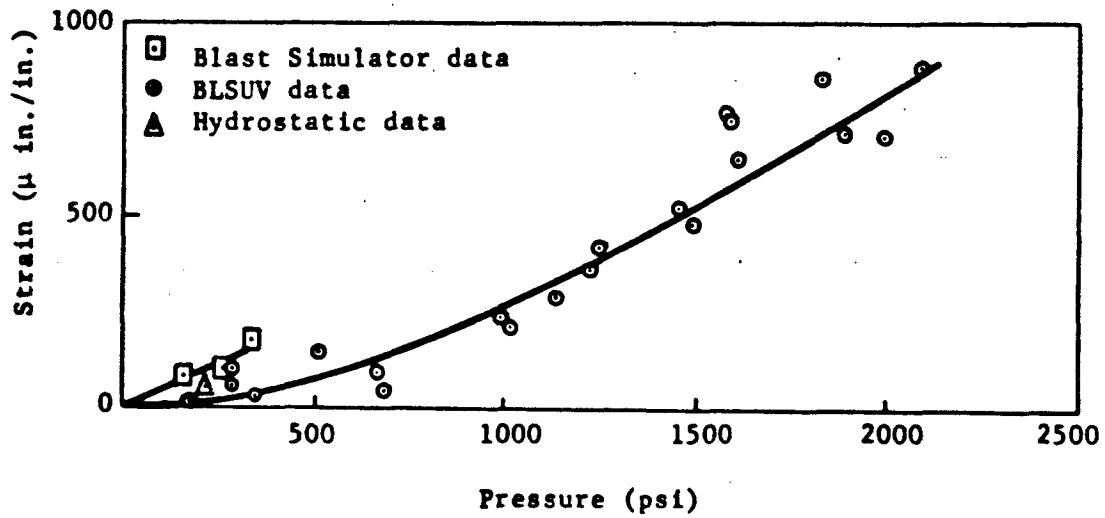

Figure 11. Strain of the disc of the 200 psi double disc gate valve

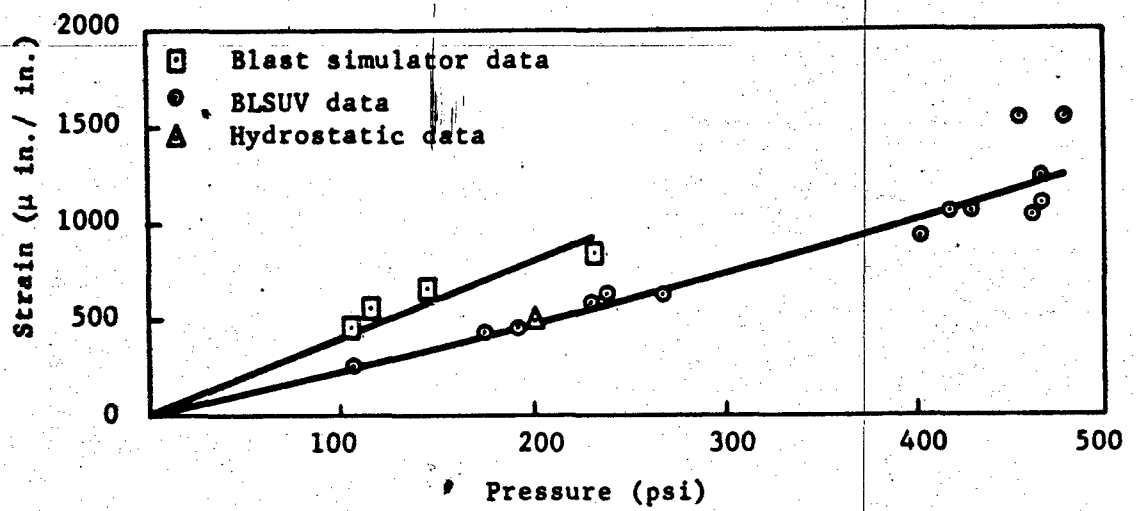

Figure 12. Strain of the disc of the 200 psi check valve

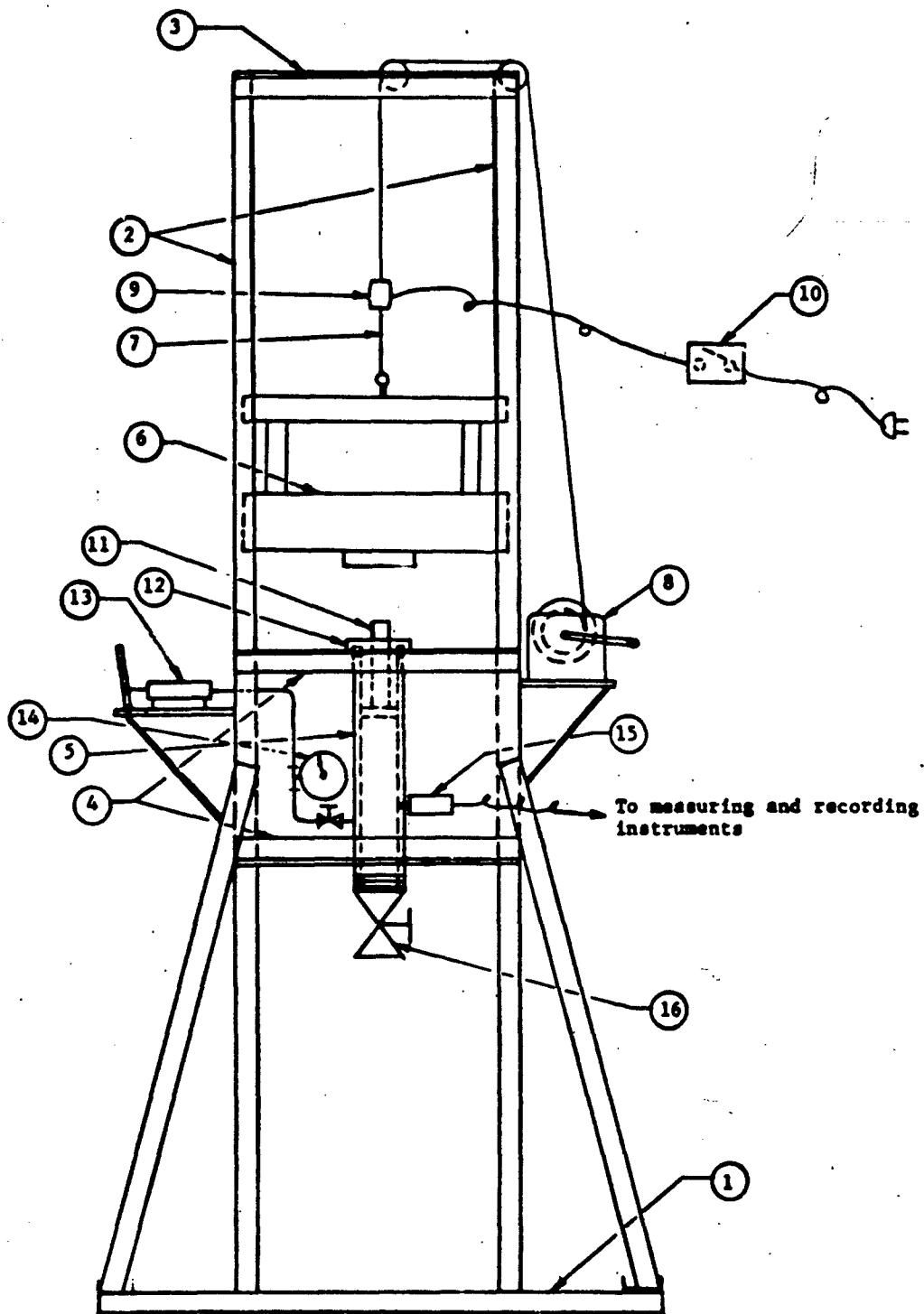

Figure 13. Blast load simulator for utility valves.

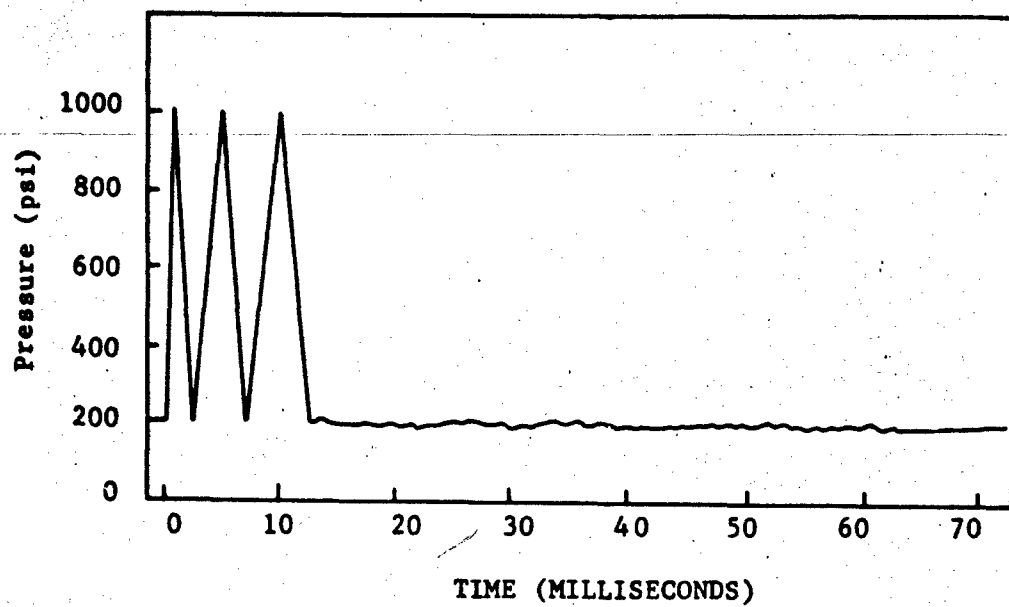

Figure 14. Typical pressure profile from the BLSUV with the test valve attached at the end of the pressure cylinder.

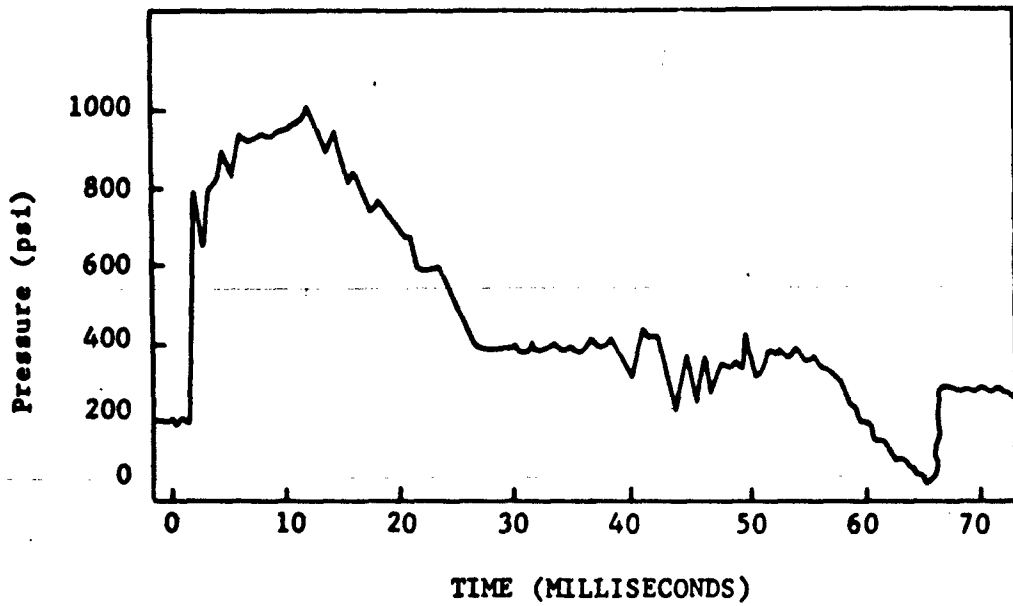

Figure 15. Pressure profile from the BLSUV at the valve when 100 feet of pipe were installed.

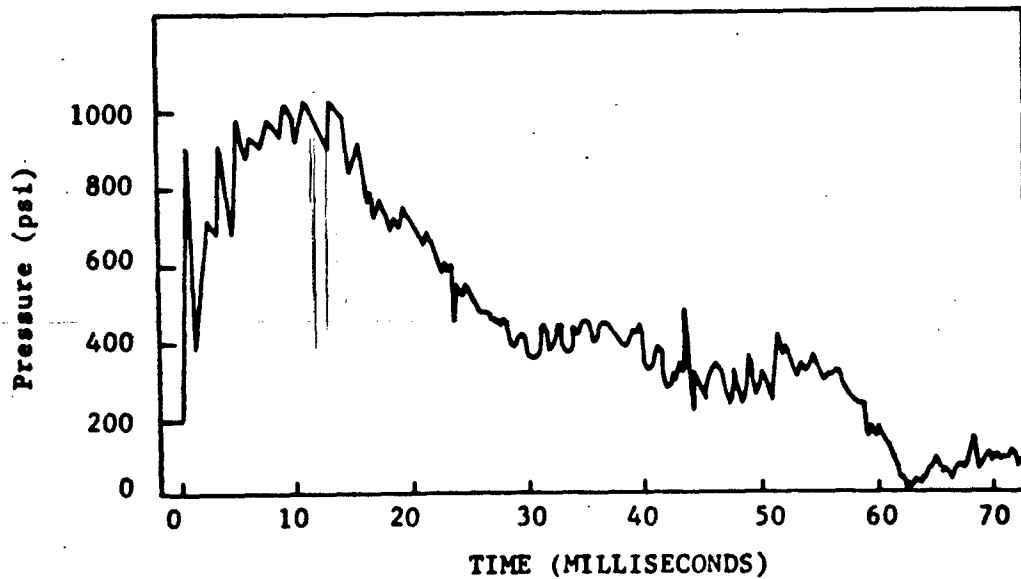

Figure 16. Pressure profile from the BLSUV at the hammer when 100 feet of pipe were installed.

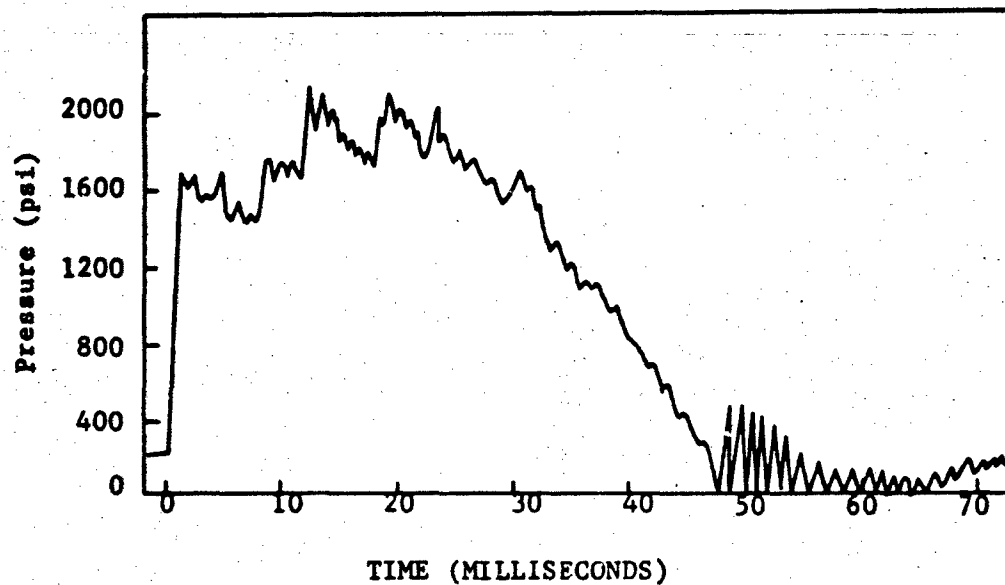

FIGURE 17. Pressure profile from the BLSUV at the valve when 20 feet of pipe were installed.

DOCUMENT CONTROL DATA - R&D

(Security classification of title, body of abstract and indexing annotation must be entered when the overall report is classified)

1. ORIGINATING ACTIVITY (Corporate author) U. S. Naval Civil Engineering Laboratory Port Hueneme, California 93041	2a. REPORT SECURITY CLASSIFICATION Unclassified
	2b. GROUP

3. REPORT TITLE

Blast Resistance of Check and Gate Valves

4. DESCRIPTIVE NOTES (Type of report and inclusive dates)
Final Report

5. AUTHOR(S) (Last name, first name, initial)

Bockman, K. R., King, J. C., and Chapler, R. S.

6. REPORT DATE November 1965	7a. TOTAL NO. OF PAGES 30	7b. NO. OF REFS 14
--	-------------------------------------	------------------------------

8a. CONTRACT OR GRANT NO. a. PROJECT NO. NCEL #Y-F011-05-02-347 c. d.	8b. ORIGINATOR'S REPORT NUMBER(S) TN-756
	8c. OTHER REPORT NO(S) (Any other numbers that may be assigned this report)

10. AVAILABILITY/LIMITATION NOTICES

**Qualified requesters may obtain copies of this report from DDC.
Release to the Clearinghouse is authorized.**

11. SUPPLEMENTARY NOTES	12. SPONSORING MILITARY ACTIVITY Bureau of Yards and Docks Navy Department Washington, D. C. 20390
-------------------------	--

13. ABSTRACT

The objective of this task was to determine the blast resistance of standard check and gate valves which may be used in protective shelter equipment and utility systems. To accomplish this objective, commercially available 3 inch 200 psi WOG (water, oil, or gas) bronze check and gate valves were subjected to transient air pressures to about 390 psi (the maximum capability of the Laboratory at the time of the tests) and to transient hydraulic pressures to about 2000 psi. Subsequent visual examination, operational tests, and hydrostatic leak tests revealed no damage to the valves, and test data indicated relatively low magnitudes of strain, which leads to the conclusion that standard check and gate valves can withstand transient loads far in excess of their rated capacity.

In order to determine whether or not the valves may be dynamically loaded when subjected to a nuclear blast wave, the natural frequencies of the valves were obtained and compared to the rise time of nuclear explosions. This showed that if a blast wave reaches the valve without attenuation, dynamic loading could occur. If, however, the wave must propagate through a piping system to reach the valve, the wave front may be relatively unchanged, or it may steepen and possibly increase the dynamic loading, or it may be attenuated so that little or no dynamic loading would occur. In the case of shocks generated by the test equipment, it was shown that dynamic loading was not applied. Because the most severe loading conditions could not be produced by the test equipment, the exact configuration in which valves are to be used must be considered before recommendations can be made as to their blast resistance.

14. KEY WORDS	LINK A		LINK B		LINK C	
	ROLE	WT	ROLE	WT	ROLE	WT
Check valves Gate valves Blast response Transient response						

INSTRUCTIONS

1. **ORIGINATING ACTIVITY:** Enter the name and address of the contractor, subcontractor, grantee, Department of Defense activity or other organization (*corporate author*) issuing the report.
- 2a. **REPORT SECURITY CLASSIFICATION:** Enter the overall security classification of the report. Indicate whether "Restricted Data" is included. Marking is to be in accordance with appropriate security regulations.
- 2b. **GROUP:** Automatic downgrading is specified in DoD Directive S200.10 and Armed Forces Industrial Manual. Enter the group number. Also, when applicable, show that optional markings have been used for Group 3 and Group 4 as authorized.
3. **REPORT TITLE:** Enter the complete report title in all capital letters. Titles in all cases should be unclassified. If a meaningful title cannot be selected without classification, show title classification in all capitals in parenthesis immediately following the title.
4. **DESCRIPTIVE NOTES:** If appropriate, enter the type of report, e.g., interim, progress, summary, annual, or final. Give the inclusive dates when a specific reporting period is covered.
5. **AUTHOR(S):** Enter the name(s) of author(s) as shown on or in the report. Enter last name, first name, middle initial. If military, show rank and branch of service. The name of the principal author is an absolute minimum requirement.
6. **REPORT DATE:** Enter the date of the report as day, month, year, or month, year. If more than one date appears on the report, use date of publication.
- 7a. **TOTAL NUMBER OF PAGES:** The total page count should follow normal pagination procedures, i.e., enter the number of pages containing information.
- 7b. **NUMBER OF REFERENCES:** Enter the total number of references cited in the report.
- 8a. **CONTRACT OR GRANT NUMBER:** If appropriate, enter the applicable number of the contract or grant under which the report was written.
- 8b, 8c, & 8d. **PROJECT NUMBER:** Enter the appropriate military department identification, such as project number, subproject number, system numbers, task number, etc.
- 9a. **ORIGINATOR'S REPORT NUMBER(S):** Enter the official report number by which the document will be identified and controlled by the originating activity. This number must be unique to this report.
- 9b. **OTHER REPORT NUMBER(S):** If the report has been assigned any other report numbers (*either by the originator or by the sponsor*), also enter this number(s).
10. **AVAILABILITY/LIMITATION NOTICES:** Enter any limitations on further dissemination of the report, other than those

imposed by security classification, using standard statements such as:

- (1) "Qualified requesters may obtain copies of this report from DDC."
- (2) "Foreign announcement and dissemination of this report by DDC is not authorized."
- (3) "U. S. Government agencies may obtain copies of this report directly from DDC. Other qualified DDC users shall request through _____."
- (4) "U. S. military agencies may obtain copies of this report directly from DDC. Other qualified users shall request through _____."
- (5) "All distribution of this report is controlled. Qualified DDC users shall request through _____."

If the report has been furnished to the Office of Technical Services, Department of Commerce, for sale to the public, indicate this fact and enter the price, if known.

11. **SUPPLEMENTARY NOTES:** Use for additional explanatory notes.
12. **SPONSORING MILITARY ACTIVITY:** Enter the name of the departmental project office or laboratory sponsoring (*paying for*) the research and development. Include address.
13. **ABSTRACT:** Enter an abstract giving a brief and factual summary of the document indicative of the report, even though it may also appear elsewhere in the body of the technical report. If additional space is required, a continuation sheet should be attached.

It is highly desirable that the abstract of classified report be unclassified. Each paragraph of the abstract shall end with an indication of the military security classification of the information in the paragraph, represented as (TS), (S), (C), or (U).

There is no limitation on the length of the abstract. However, the suggested length is from 150 to 225 words.

14. **KEY WORDS:** Key words are technically meaningful terms or short phrases that characterize a report and may be used as index entries for cataloging the report. Key words must be selected so that no security classification is required. Identifiers, such as equipment model designation, trade name, military project code name, geographic location, may be used as key words but will be followed by an indication of technical context. The assignment of links, roles, and weights is optional.