

AD620418



AN INVESTIGATION OF SHORT LINE TRIANGULATION ACCURACIES
COMBINED WITH THE FIELD TESTING OF A KERN DKM-3
MODIFIED WITH A 5-WIRE RETICULE

300 0.75 42 181

by

Darwin Gene Abby, B.S.

The Ohio State University

1965

SEP 15 1965
JISA

ABBY, DARWIN GENE

BAPS

AN INVESTIGATION OF SHORT LINE TRIANGULATION ACCURACIES
COMBINED WITH THE FIELD TESTING OF A KERN DKM-3
MODIFIED WITH A 5-WIRE RETICULE

1965, The Ohio State University

Contract No AF-33(608)-1095

3 cys recd: 1-DDC, 1-AU, 1-AFIT

AN INVESTIGATION OF SHORT LINE TRIANGULATION ACCURACIES
COMBINED WITH THE FIELD TESTING OF A KERN DKM-3
MODIFIED WITH A 5-WIRE RETICULE

A Thesis

Presented in Partial Fulfillment of the Requirements
for the Degree Master of Science

by

Darwin Gene Abby, B.S.

The Ohio State University

1965

Approved by



Advisor
Department of Geodetic Science

ACKNOWLEDGEMENTS

The author wishes to express his appreciation to the staff of the Ohio State University Department of Geodetic Science, and especially to Dr. U. A. Uotila for their assistance and guidance throughout this investigation.

Special thanks goes to Mr. H. J. Wehrli, Vice President of Kern Instruments Incorporated, who presented the author with reports and aids useful in this study and suggested and accomplished the modification of the Geodetic Science Department's DKM-3 with a 5-wire reticule for investigation. Mr. Wehrli was also kind enough to loan two Kern Targets and associated equipment for use in the field work.

The author is also grateful to Col. R. G. Greenlees, Commander of the 1381st Geodetic Survey Squadron, who made possible the loan of tribrachs and omni-lights for use in the study.

Last of all, the author wishes to express his deep appreciation to Mr. Jack Cook for his help in the field operations.

the T-3 observations, under different conditions and using various procedures.

Chapter 2

INSTRUMENTATION

2.1 Production Targets

The target required for a specific job is dependent on the length of lines observed, the accuracy of centering, and the method of centering. There are several targets produced by instrument corporations which are suitable for short line work.

Two of the most commonly used targets available from instrument companies include the Wild and Kern Traverse Targets. The specifications given for the Kern Target are: it is suitable for sights of 20 meters to 1 kilometer and has an eccentricity between symmetry axis and autocentering plug of ± 0.3 to 0.4 millimeters [8].

The Wild and Kern Traverse Targets were used in this field test. The Wild Target with the base plate removed was set directly into the grooves on the tribrach as shown in Figure 1a. The Kern Target was used with a trivet which also sets in the grooves of a tribrach as shown in Figure 1b. Both targets were durable and easy to set up after the stand was centered. The theodolite crosshair is centered directly on the illuminated "V" of the Wild Target while the illuminated "cross" of the Kern Target is centered by symmetry of light around the crosshair. Both systems are centered



Figure 1a
WILD TRAVERSE TARGET



Figure 1b
KERN TRAVERSE TARGET

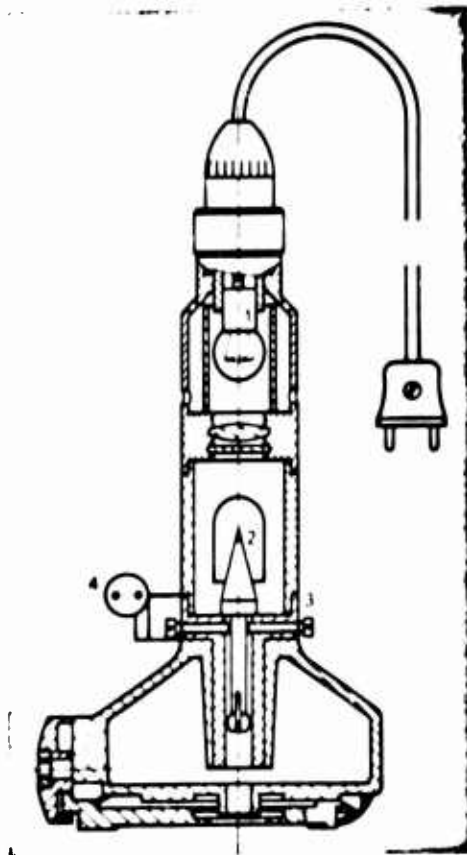

Figure 1c
POINT TARGET



Figure 1d
TARGET FOR SHORT SIGHTS

with ease and precision.

The longest line observed was 4,720 feet long and although the Kern and Wild Target Faces were visible and acceptable results were obtained, the pointings were very tedious. The maximum distance of 1 kilometer recommended by Kern should be adhered to for best results.

The point target designed by Kern has an adjustable point which is illuminated from above. (See Figure 1c) This target gives a very definite point for observing when utilized on short lines. The eccentricity of the center point with respect to the autocentering plug is less than ± 0.02 millimeters [8].

A third target designed by Kern for short sights, fits directly in the Kern Trivet center hole. It has an effective distance of from 4 to 40 meters with a centering error of ± 0.03 millimeters. (See Figure 1d)

2.2 Nonproduction Targets

Many using organizations design and produce their own targets and fixtures to meet their requirements. A target designed for the survey of the Telstar Tracking System consisted of two 0.25 inch steel plates joined at right angles. One plate was the base and was fixed with three leveling screws and a bull's eye bubble. The second plate had a machined slot 4 inches long and 0.02 inches wide cut vertically over a precisely placed brass pointer. The target

was used at night with a variable light source located behind the slot. No centering error was given, but excellent results were obtained. The survey consisted of seven stations with 17 lines ranging in length from 149 to 630 meters observed. Three short baselines were included in the adjustment which had an average correction to a direction of 0.37 seconds of arc and a probable error of a single observation of ± 0.46 seconds [15].

Targets selected for use on the Glen Canyon Dam Deformation studies were chosen from a variety of designs tested in the field [13]. The pier target was machined from a solid piece of metal with a painted face 1.5 inches square. The centering was accomplished with a 0.5 inch tapered stub axis which fit tightly into the center hole of the tribrach. (See Figure 2) The permanent targets selected for the intersection stations on the face of the dam were 0.5 inch diameter cylinders painted with red and white stripes and placed in a frame painted flat black. These targets had no self illumination and were therefore used in the early morning hours or with floodlights. Several of their trial patterns for target faces are shown in Figure 3.

A third target used in this field test was the omnilight, which was designed by a member of the United States Air Force for use in triangulation work done for control of various missile guidance systems. (See Figure 4) The omni-

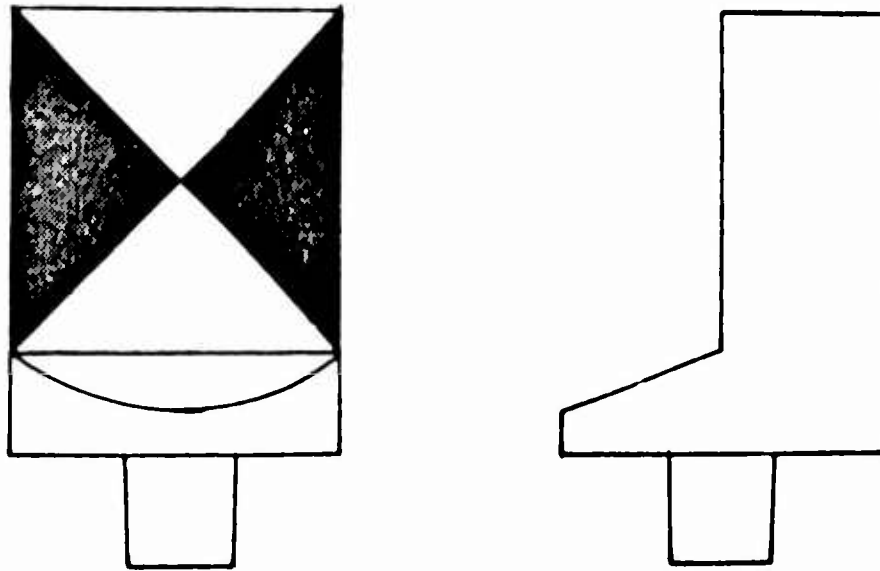

Figure 2

GLENN CANYON DAM DEFORMATION TARGET

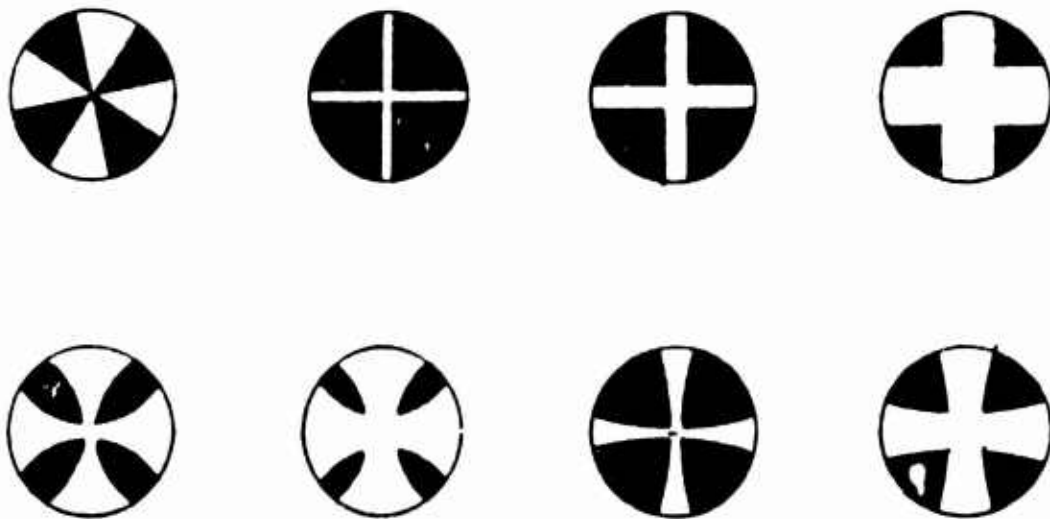

Figure 3

TRIAL PATTERNS

light is best suited for lines of 100 feet to 1 mile. The actual point of sighting is the bulb filament which may have a length of 1 to 2 millimeters, but when viewed through the theodolite scope, it is only a point source of light. When the illumination is properly adjusted, the target has the appearance of a 4th magnitude star. The bulb may have any voltage desired, but must have a screw base. The best results were obtained in this test using a 6 volt bulb with 1.5 to 3 volts of power depending on the length of the line. The proper adjustment of intensity requires a knowledge of the distance and the proper illumination or else a second person must adjust the illumination as the observer sights with the theodolite. An additional aid for use with this target is a variable power supply with a blinker device which gives an intense flash of light for a fraction of a second, making identification easier. The target has no leveling capability and must therefore be used on a level support. The bulb filament is approximately 6 centimeters above the support so that a 1 degree tilt causes a 1 millimeter error in centering.

Bulb filaments are not centered when manufactured, which makes it necessary to center a new bulb placed in the holder. The target has two adjustable movements which are secured by 4 screws located on the top of the target. To center the filament, sight with a secondary instrument placed

a few feet away on the filament and then turn the target 180 degrees. If the filament moves off center, it can be adjusted by loosening the screws and moving the filament one half of the error. After checking this position, the target is turned 90 degrees and the same process repeated.

The omni-light has a 2 centimeter diameter stub axis with several sizes of adapters for use with tribrachs or any other centering device with the proper size hole.

The main Advantage of this target is that it may be observed from any direction or it may even be observed simultaneously.

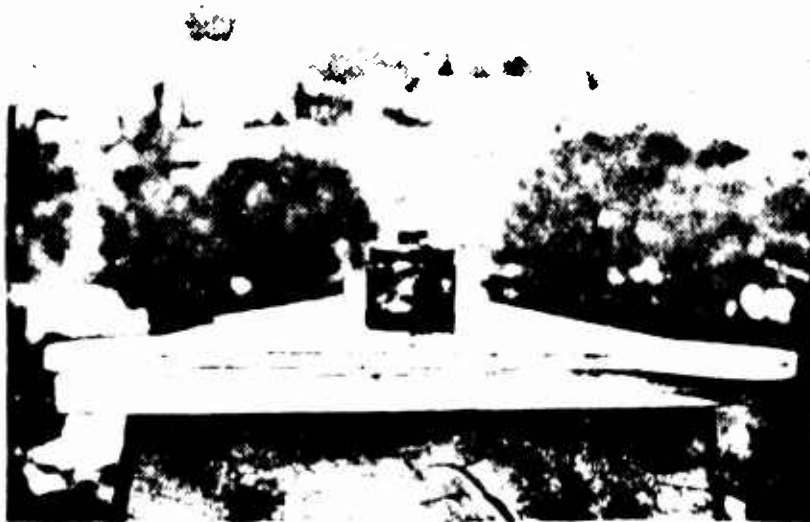

Figure 4
OMNI-LIGHT

2.3 Target and Instrument Support

In order to minimize centering and observation errors, it is necessary to have a sturdy support. The best solution

to this problem is the concrete monolith, with combined control point and centering device secured to the top of the monolith. A second type of support which is not as permanent, is the wooden or metal stand. The main problem with this support is that there is a loss of accuracy in centering over the ground marker. The tripod will not be considered as an instrument support for short line work because of its instability.

The reinforced concrete monolith is effective only when placed on good footing. If bedrock is close to the surface, it should be used for footing, otherwise a concrete footing is necessary. The best specifications for such a footing were utilized in the Telstar Tracking Survey. The subsurface portion was 6 feet deep, 6 feet square on the bottom and 4 feet square on the top. The pedestal was 40 inches high with a tribrach mounted on the top. This design gives a large bottom surface to prevent settling and the soil on the sloping sides prevents tilting. After construction, the monolith should be allowed to cure and settle before any measurements are taken.

One minor problem with the concrete monolith is movement due to the heating and cooling effects of the direct sunlight. The errors caused by this movement are small, but could cause problems in cases of very short lines. The remedy for this problem is to protect the pedestal with an

outer shell which leaves a small air space for insulation or construct a shelter.

The field observations for this study were accomplished using 4 foot wooden stands. By using extreme care, it was possible to obtain accurate results.

The stands were built to USC&GS specifications [17], positioned over the ground markers and weighted with 3 fifty pound sandbags per stand. (See Figure 5) A three grooved tribrach was then screwed to the top of the stand. All the stations used in this test were located on concrete or stable tar and gravel roofs. If the stands are to be placed over stations on the ground, it is necessary to embed the legs of the stand in the soil and weight heavily.

The centering of the stands over the ground marker was the main problem. It was accomplished by using two offset instruments approximately 30 feet away and at right angles. A pin was positioned on the center of the ground mark and an omni-light was set in the tribrach on the stand. The stand was then moved until the pin and the target were aligned by both instruments. The accuracy of this technique is discussed in section 3.2 .

The time and effort required to center stands using this method are high, but in short line work with stands, great care must be taken. A device used by the Air Force and the USC&GS to eliminate some of the work involved is the

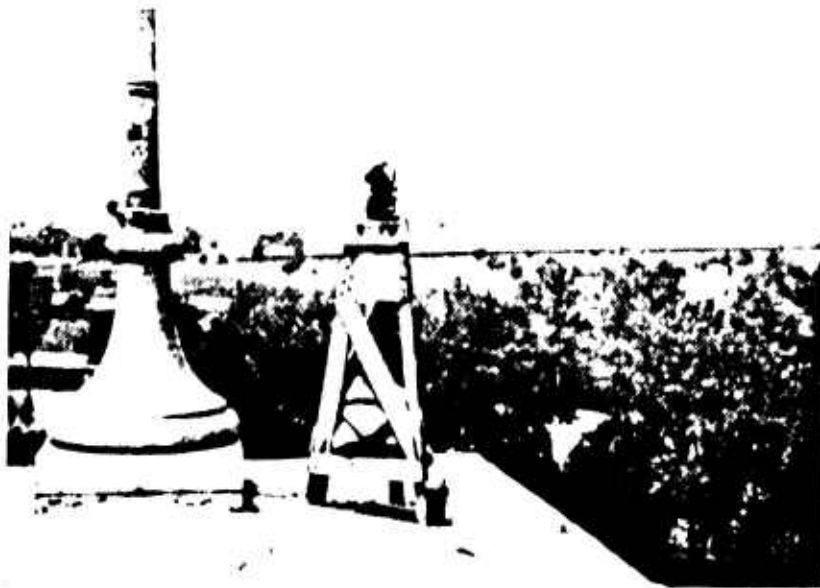

Figure 5

4 FOOT WOODEN STAND WITH THEODOLITE

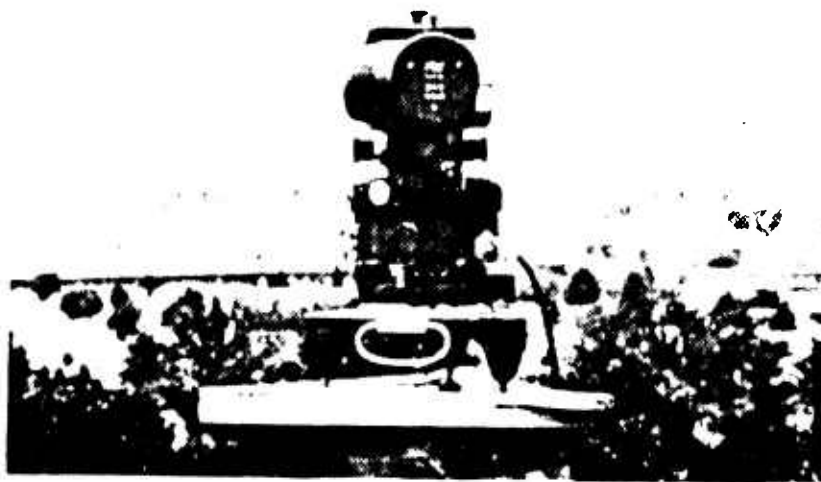

Figure 6

KERN DKM-3 MOUNTED ON TRIBRACH

adjustable tribrach. The grooved portion is round and held in a metal frame by 4 setscrews which slide the tribrach in the frame. The stand is centered roughly and then the final accurate centering obtained by adjustment of the 4 screws.

2.4 Theodolites

The Wild T-3 theodolite number 26794 was utilized in the control extension phase. This instrument, with the base plate removed, sat directly into the grooves of the tribrach. The T-3 was checked completely before use and found to be in good adjustment. A 15 second collimation error was removed before use, but when the instrument was jostled or transported, the collimation error returned. It was finally concluded that a prism in the micrometer system was loose and the collimation error was left alone. The results were never noticeably effected.

The instrument used in the second phase of the short line investigations was the Kern DKM-3 number 65303 modified with a 5-wire reticule. The DKM-3 was checked and found to be in good adjustment. It was used with the Kern Trivet and set directly in the tribrach grooves. (See Figure 6)

2.5 The 5-Wire Reticule

The reticule has 5 short vertical lines with spacing of 4 minutes of arc between the lines. The number three wire is the regular center crosshair. (See Figure 7)

This device is a tool designed to replace repetition of 5 series with 5 pointings in one series and is used with the knowledge that instrumental errors in the modern theodolite are a minimum. The main error involved if the number of series are reduced is the systematic one caused by horizontal circle distortions.

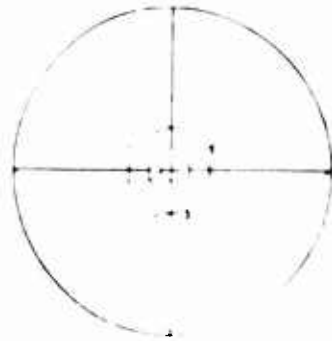

Figure 7

5-WIRE RETICULE

The total error in the measurement of a direction consists of an observation error and a graduation error. Fondelli [3] showed in his examination of the horizontal circles in three DKM-3 theodolites, that the average observation error was 0.3 seconds and the average graduation error was only 0.1 seconds. This being the case, it is possible to replace 5 series with 1 series of 5-wire readings with no systematic error. New series can still be initiated at a new plate setting, but if 15 pointings are required, the number of plate settings using the 5-wires will only be three compared to the usual one per series.

Chapter 3

CENTERING ANALYSIS

3.1 Standard Error of Observed Angle Due to Noncentering

The centering of theodolite and targets over the control point is a critical procedure in short line triangulation. The errors in centering can best be seen from the following derivation [4]. (See Figure 8)

Let

O = True vertex for angle BOA

P = Actual instrument center

$L_{1,2,3}$ = Theoretical lengths of sides 1, 2, and 3

$L'_{1,2}$ = Actual lengths of lines of sight 1 and 2

θ = True horizontal angle

θ_1 = Measured horizontal angle

ϵ = Error in theodolite setup

$\Delta\theta = \theta - \theta_1$ = Angular error

From the Figure

$$\Delta\theta = a_1 + a_2$$

$$\sin a_1 = \frac{\epsilon \sin(360-b)}{L'_1} \quad (3.1)$$

$$\sin a_2 = \frac{\epsilon \sin(b-\theta)}{L'_2} \quad (3.2)$$

a_1 and a_2 are very small and therefore they may be measured in radians, and L_1 and L_2 equal L'_1 and L'_2

respectively giving the following.

$$a_1 = - \frac{\epsilon \sin b}{L_1} \quad (3.3)$$

$$a_2 = \frac{\epsilon (\sin b \cos \theta - \cos b \sin \theta)}{L_2} \quad (3.4)$$

and

$$\Delta\theta = - \epsilon \left[\left(\frac{1}{L_1} - \frac{\cos \theta}{L_2} \right) \sin b + \left(\frac{\sin \theta}{L_2} \right) \cos b \right] \quad (3.5)$$

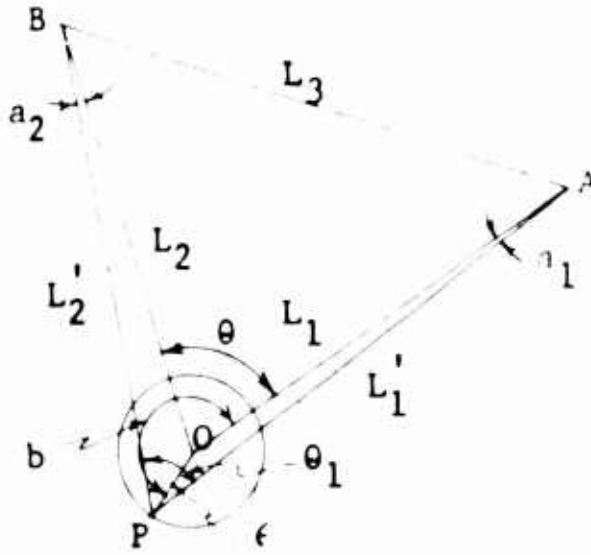

Figure 8

CENTERING ERROR

Let
$$P = \frac{1}{L_1} - \frac{\cos b}{L_2} \quad (3.6)$$

$$Q = \frac{\sin \theta}{L_2} \quad (3.7)$$

Then
$$\Delta\theta = - \epsilon (P \sin b + Q \cos b) \quad (3.8)$$

From these last equations, it can be seen that $\Delta\theta$ is dependent on the magnitude of L_1 , L_2 , θ , ϵ , and b . The first three values are known from measurements and ϵ is

approximated from experience. b will vary as can be seen in Figure 8 from $-\pi$ to π in a random fashion. If it is assumed that b will be uniformly distributed throughout this interval, it will satisfy all the criteria of a normally distributed error. The fundamental expression for the standard error of $\Delta\theta$ will then be

$$m_{\Delta\theta}^2 = \frac{1}{2\pi} \int_{-\pi}^{\pi} (\Delta\theta)^2 db \quad (3.9)$$

and after integration

$$m_{\Delta\theta}^2 = \frac{\epsilon^2(P^2 + Q^2)}{2} \quad (3.10)$$

Now let

$$P^2 + Q^2 = \left(\frac{1}{L_1} - \frac{\cos \theta}{L_2} \right)^2 + \left(\frac{\sin \theta}{L_2} \right)^2 = \frac{L_3^2}{L_1^2 L_2^2} \quad (3.11)$$

Therefore
$$m_{\Delta\theta} = \frac{\epsilon L_3}{\sqrt{2} L_1 L_2} \quad (3.12)$$

In order to arrive at a quantitative figure, let $L_1 = L_2 = L$, which is close to the usual case, and then

$$L_3 = 2 L \sin \frac{\theta}{2} \quad (3.13)$$

and

$$m_{\Delta\theta} = \frac{\sqrt{2} \epsilon}{L} \sin \frac{\theta}{2} \quad (3.14)$$

This equation is plotted in Figure 9 for a value of $\epsilon = 0.5$ millimeters and different values for θ and L .

3.2 Target Centering Errors

A test was conducted on the targets used in this project to measure any possible centering errors they might have and to evaluate the plumbing procedures used in centering

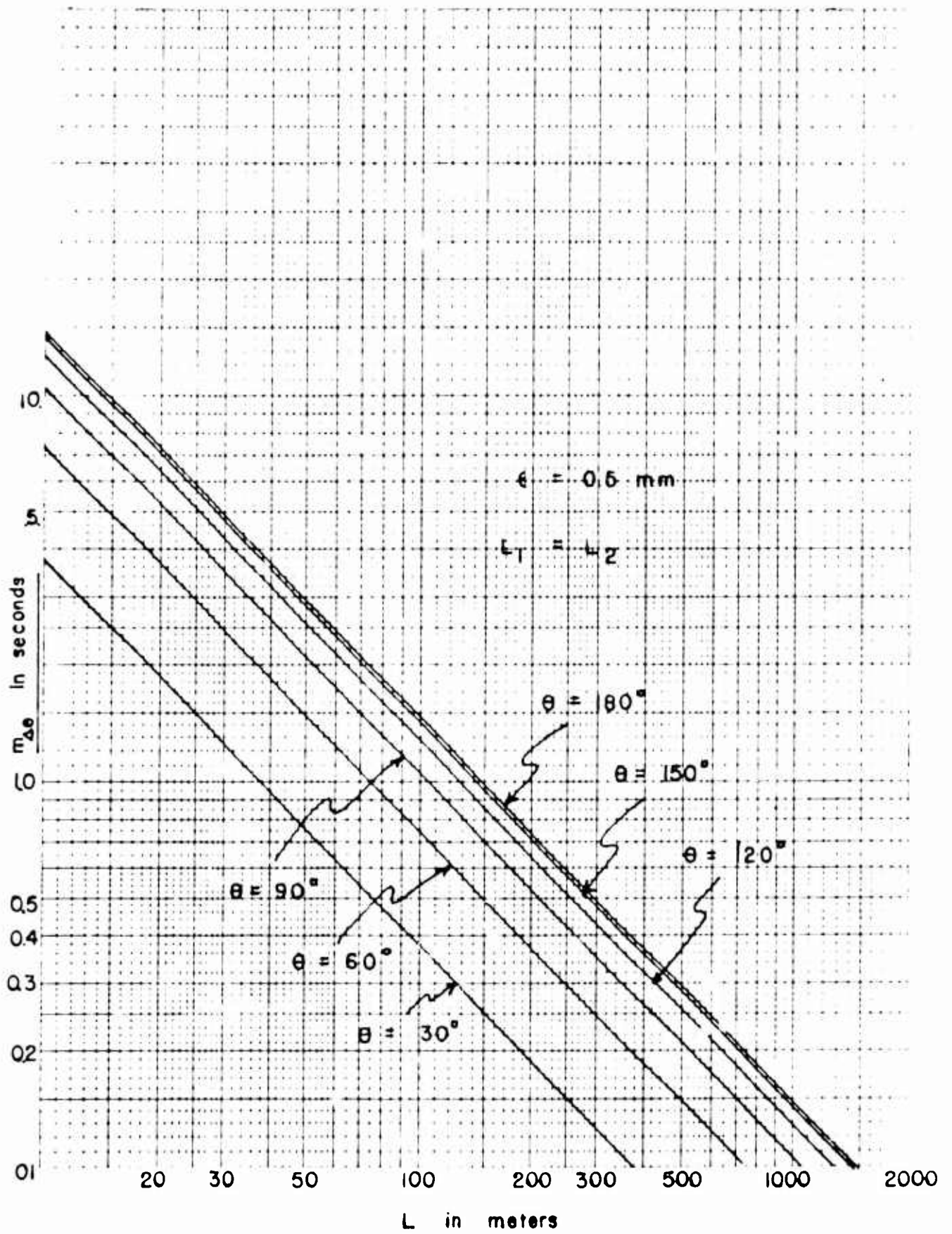

Figure 9
 GRAPH OF STANDARD ERROR OF OBSERVED ANGLE
 DUE TO CENTERING ERROR

the wooden stands.

One of the stands was set on a stable surface and a millimeter scale was positioned on the ground under the center of the stand. A second order theodolite was then placed approximately 30 feet away and used to transfer target centers to the scale. Each target was positioned 4 times with a 120 degree rotation between each reading, and in the case of the Kern equipment, a reading was also taken on the centering device of the trivet. The fourth reading was taken only to compare with the first since this was actually the same position. The check between the first and fourth reading gave an indication of the size of the accidental errors. The measurements are listed in Table 1.

The first set of readings were made on a straight pin like that used in centering the stands, to check the consistency of pointing on such a target. The readings all checked within 0.1 millimeters. Next, the accuracy of the offset instrument was checked by taking direct and reverse readings on the transfer of a Wild Target to the scale. These readings ranged from 0.0 to 0.2 millimeters in difference. Since a difference of 0.2 millimeters was twice the error, the average error of the transfer of centers by the offset instrument was assumed to be 0.1 millimeter.

The true center was considered to be the mean of the first three readings on all of the targets and the

Table 1

TARGET CENTER MEASUREMENTS

Target	Position 1	Position 2	Position 3	Position 4
Pin	103.6 mm	103.6 mm	103.6 mm	
Wild*	103.5	103.6	103.8	103.5 mm
Wild**	103.6	103.4	103.7	103.6
Omni-light	103.2	103.3	103.2	
Kern 1	103.8	104.0	103.9	103.8
Trivet pt. 1	103.3	103.3	103.8	103.3
Kern 2	103.9	103.7	103.5	103.9
Trivet pt. 2	103.7	103.2	103.4	103.6
Wild 2	103.7	103.4	103.6	103.7
Wild 1	103.5	103.6	103.8	103.5

* Offset instrument in the direct position
** Offset instrument in the reverse position

Table 2

CENTERING ERRORS

Target	Position 1	Position 2	Position 3
Omni-light	0.4 mm	0.3 mm	0.4 mm
Kern 1	-0.2	-0.4	-0.3
Trivet pt. 1	0.3	0.3	0.2
Kern 2	-0.3	-0.1	0.1
Trivet pt. 2	-0.1	-0.4	-0.2
Wild 2	-0.1	0.2	0.0
Wild 1	0.1	0.0	-0.2

differences of each reading from the mean are listed in Table 2 . The average centering errors of the Kern and Wild Targets were 0.23 and 0.10 millimeters respectively. The average error of all the targets was 0.21 millimeters and the maximum error was 0.4 millimeters.

A test conducted by Jones [5] on several kinds of targets gave approximately the same results. He divided the total target error into several components and measured each component with a much higher degree of accuracy than was obtained in the test made for this paper. The errors are illustrated in Figure 10 .

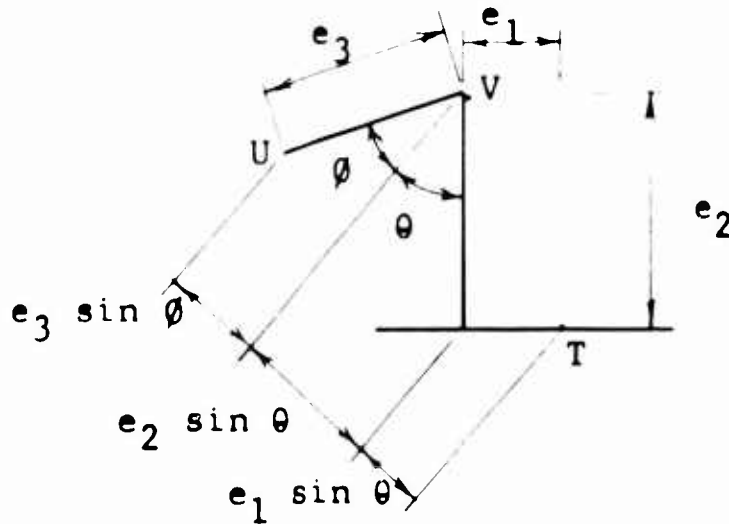

Figure 10
TARGET ERRORS

The eccentricity between the target center T and the vertical axis was divided into e_1 the error parallel to the target face and e_2 the error normal to the target face. The eccentricity between the vertical axis V and the centering

axis U was designated as e_3 . The total error, when the target face was assumed not normal to the line of sight, was then $e = e_1 \cos \theta + e_2 \sin \theta + e_3 \sin \theta$. In all cases, the angle θ was found to be extremely small giving the final total error as $e = e_1 + e_3 \sin \theta$. Irregular errors such as variations in clamping pressures, tolerance in fits, tilt of the vertical axis, and releveled were also considered and measured. The values obtained for the Kern and Wild Traverse Targets are listed in Table 3.

Table 3
TARGET ERRORS

Target	e_1	e_3	Irregular
Kern	.147 mm	.005 mm	.013 mm
	.178	.028	
Wild	.177	.109	.015
	.194	.081	

If the $\sin \theta$ is given the maximum value of 1, the total average error for the Kern and Wild Targets are 0.19 and 0.30 millimeters respectively.

3.3 Total Error in Centering of Targets

The error in the centering of a stand and target is the combination of a 0.1 millimeter average error in the transfer from pin to the target with the offset instrument and the average target centering error of 0.2 millimeters. The total error at the target station is then 0.3 millimeters. The

same error occurs at the instrument station because the same centering procedures are used. The total average linear error for a direction due to noncentering is then 0.6 millimeters.

By entering the graph in Figure 9 with an average length of lines observed in this test of 800 meters and a value for θ of 90 degrees, the standard error of a direction due to 0.5 millimeters centering error is 0.13 seconds of arc. The difference between 0.5 and 0.6 millimeters as calculated is negligible. This analysis indicates that centering errors were of no consequence in this test.

Chapter 4

PROCEDURES

4.1 Single Wire Procedures

Two of the four full sets of observations completed on the test quadrilateral were made using normal first order observing procedures outlined in the USC&GS Special Publication number 247 [17]. One of these sets was made with the Wild T-3 and the second set was observed with the DKM-3 using only the number three wire on the reticule.

4.2 5-Wire Observation Procedures

The method of observation by series was adopted with the additional requirement that a pointing with each of the 5 wires be made on each target and the horizontal circle readings taken. The procedure was to center the number 1 wire on the initial target, read the scale, proceed to the next wire with the slow motion screw and continue until reaching the number 5 wire. This procedure was followed on each target moving in a clockwise pattern. After the last wire had been read on the last target, the instrument was reversed and the process continued counterclockwise on the targets. The number 1 wire was still read first on each target. The series ended with the number 5 wire on the initial target. A new series was commenced by centering the

number 1 wire and making a new plate setting. After making the plate setting, the wire should be recentered with the slow motion screw according to accepted observing procedures. This was not accomplished in all cases therefore giving rise to a possible systematic error.

An alternate procedure is to center the number 5 wire after reversing the instrument on the last target. The wires are then centered and the readings taken in the order of 5 through 1 on the counterclockwise return to the initial target. This places the number 1 wire in position to begin the next series automatically. This technique was not used in the field, but was tested in order to compare the two systems. The test and analysis are discussed in section 5.5 .

A second alternate procedure would be to start with the number 5 wire in all cases. This procedure was not tested, but is consistent in all rules of instrument motion. Systematic errors plagued the field observations and this procedure could possibly have solved some of the problems if it had been tried.

The plate settings adopted for 3 series of 5-wire readings were:

0°	20'	15"
60°	00'	30"
120°	20'	45"

The coverage of the horizontal circle is limited, but the

errors caused by this lack of coverage were found to be negligible in section 2.5 . The micrometer coverage, however, is thorough. Due to the 4 minute separation of the wires in combination with a 5 minute micrometer, the whole scale is observed at 1 minute intervals for each target. For example, in Figure 11, the first set of readings on the target at ARENA excluding multiple units of 5 minutes are 0, 1, 2, 3, and 4. The seconds scale coverage is controlled by the plate setting and is sufficient. The 20 minute setting for the direct positions eliminates going below 0 minutes as the instrument moves counterclockwise from wires 1 to 5. When different numbers of series are being observed, plate settings for the horizontal circle can be determined by dividing 180 degrees by the number of series.

4.3 General Observation Procedures

The observer was unfamiliar with the collimation by symmetry technique, but after some practice, proficiency was acquired. Collimation was made approximately 3 to 4 times to obtain agreement for a single value which was given to the recorder. Alignment was always approached from the same side of the scale in order to eliminate any systematic error in the micrometer.

All observations were made at night to minimize refraction and heat distortion. The centering of the stands was checked every afternoon and the observations began

immediately after sundown. The number of stations observed in one night varied from 2 to 3 .

4.4 Recording Procedures for the 5-Wire Method

A sample recording sheet is shown in Figure 11 with the sequence given by the small circled numbers. The field calculations for a series are very simple. A single direction is the mean of 10 seconds values with the degrees and minutes being taken from the direct reading on the number 3 wire. After the direction to each target is obtained, a reduction to zero initial is made by subtracting the direction of the initial target from the remaining target directions.

4.5 Observation Procedures for Astronomic Azimuth

In addition to the tests in direction measurements, the 5-wire reticule method was tested on observing astronomical azimuths. The basic techniques used in angle measurements are also used in azimuth observations with one ground target being replaced by the pole star.

Station ASTRO, which is a concrete monolith included in the extension survey, was chosen as the instrument station for this test and the targets were NORTH BASE and LANE, which were also in the campus net. The normal procedure outlined in section 4.2 was used observing the two ground targets. After the targets had been sighted and the readings taken, the pole star was tipped with all five wires

STATION: LANE DATE 13 MAY 65 INSTR. DKM-3 OBS. ABBY WEATHER CLEAR T. 60° WIND NW-5

STA.	ARENA	STADIUM	SISSON	ARENA	STADIUM	SISSON	ARENA	STADIUM	SISSON					
DIR. 1	20	08.9	044	09.5	09.5	49	01	26.6	248	54	25.3	269	30	24.0
DIR. 2	16	6.6	23	6.4	6.4	45	05	24.3	58	58	23.6	34	34	22.7
DIR. 3	12	8.4	13	6.5	6.5	41	09	26.3	249	02	21.8	38	38	23.5
DIR. 4	08	9.5	14	7.3	7.3	37	13	25.2	06	06	22.4	42	42	24.0
DIR. 5	04	9.2	15	7.8	7.8	33	17	24.1	10	10	20.8	46	46	20.8
SUM.		111.8		33.5	33.5			126.5			113.9			115.0
REVERSE	04	14.6	24	14.1	14.1	33	17	17.7	69	10	19.5	89	46	15.0
REVERSE	08	13.0	25	12.9	12.9	37	13	18.7	06	06	17.5	42	42	17.5
REVERSE	12	15.8	26	14.4	14.4	41	09	19.6	02	02	19.7	38	38	17.6
REVERSE	16	13.7	27	11.4	11.4	45	05	18.5	68	58	19.9	34	34	17.5
REVERSE	20	12.1	28	11.5	11.5	49	01	19.8	54	54	20.7	30	30	19.5
SUM.		111.8		97.8	97.8			220.8			211.2			205.1
DIR. 1	12	11.8	24	10.49	10.49	44	09	22.08	69	02	21.12	89	38	20.31
DIR. 2	00	00.00	23	59.31	59.31	44	00	00.00	23	52	59.04	44	28	58.23
REVERSE	18	42.0	114	40.7	40.7	134	04	45.1	338	57	42.5	359	33	41.6
REVERSE	14	40.5	115	41.4	41.4	133	08	43.2	339	01	42.4	37	37	40.2
REVERSE	10	40.7	116	41.3	41.3	132	12	43.8	05	05	40.4	41	41	39.9
REVERSE	06	41.3	117	41.8	41.8	131	16	44.1	09	09	40.3	45	45	40.0
REVERSE	02	42.6	118	42.8	42.8	130	20	42.0	13	13	41.0	49	49	39.3
SUM.		207.1		206.8	206.8			215.2			206.6			201.0
DIR. 1	270	02	49.5	47.5	47.5	314	20	37.0	159	15	34.6	179	49	36.7
DIR. 2	06	47.5	59	48.2	48.2	35	16	36.7	09	09	37.1	49	49	39.0
DIR. 3	10	46.8	69	46.2	46.2	39	12	37.0	05	05	34.5	45	45	36.0
DIR. 4	14	47.2	79	46.4	46.4	43	08	38.0	01	01	37.5	41	41	35.3
DIR. 5	18	46.0	89	43.5	43.5	47	04	37.4	57	57	38.0	37	37	37.0
SUM.		444.1		442.0	442.0			402.3			388.3			385.0
DIR. 90	10	44.91	119	43.98	43.98	134	12	40.23	159	05	38.83	179	49	38.50
ANG. 0	00	00.00	23	59.57	59.57	44	00	00.00	23	52	58.60	44	28	58.27

Figure 11

5-WIRE HORIZONTAL DIRECTION NOTES
SAMPLE COPY

starting with number 1 . The instrument was then reversed and the star was tipped five more times starting with the number 1 wire. The ground targets were then sighted in reverse order completing the series. The average time taken for the 10 pointings on the star was 9 to 10 minutes. With more experience this time could be cut to 6 or 7 minutes. Using this observing sequence, there is approximately a 5 minute time difference between the direct and reverse pointings, therefore, a curvature correction must be made. If the observing sequence on the star is changed so that the number 5 wire is read first after plunging the scope, the time difference will vary from 1 minute for the 5-wire readings to 9 minutes for the number 1 pair of readings.

To eliminate any possible systematic error, the direct and reverse pointings with the same wire were always combined for the calculations. The mean direction for the star, each target, and the mean time are calculated on the field record and used in the azimuth calculations. A sample recording form is shown in Figure 12.

The main advantage of this system is that the instrument remains in a single position for 5 star pointings. With the striding level mounted on the DKM-3, maneuvering the theodolite becomes cumbersome and the striding level is constantly being bumped. This method eliminates part of this problem and allows the striding level time to settle. For speed, the bubble could be read on wires 1 and 5 and meaned.

STA.	NORTH	BASE	LANE	POLARIS	TIME	DIFF.	L	R	STATION:							
1	D	0	20	14.0	65	10	53.0	356	26	28.9	6	00	33.5	35.9	06.9	ASTRO
	R	180	04	23.5	244	54	59.5	176	07	25.8	6	05	44.7	07.0	36.0	27 MAY 65
	MEAN	0	12	18.8	65	02	56.2	356	16	57.4	6	03	09.1	5	1125	DKM-3
2	D	0	16	13.0	65	06	52.6	356	21	36.5	6	01	24.0	35.9	06.9	LEVEL VALUE 4"
	R	180	08	21.9	244	58	59.9	176	12	54.9	6	06	45.0	07.0	36.0	CHRON.
	MEAN	0	12	17.4	65	02	56.2	356	17	15.7	6	04	04.5	5	20.5	WEATHER CLEAR
3	D	0	12	12.6	65	02	52.5	356	16	40.4	6	02	06.0	35.9	06.9	TEMP 65°
	R	180	12	21.5	245	02	62.2	176	18	18.0	6	07	32.2	06.9	35.9	WIND N-S
	MEAN	0	12	17.0	65	02	56.4	356	17	29.2	6	04	49.1	5	26.2	0
4	D	0	08	12.5	64	58	56.2	356	11	41.5	6	02	36.5	35.9	6.9	CNCR
	R	180	16	20.0	245	06	57.9	176	23	42.1	6	08	28.5	06.9	35.9	21 10 EST
	MEAN	0	12	16.2	65	02	57.0	356	17	41.8	6	05	32.5	5	52.0	05 52 05.5
5	D	0	04	15.3	64	54	53.3	356	06	42.7	6	03	14.5	35.9	6.9	CNCR
	R	180	20	20.6	245	10	57.1	176	29	08.1	6	09	20.5	6.9	35.9	21 10 EST
	MEAN	0	12	18.0	65	02	55.2	356	17	55.4	6	06	17.5	6	06.0	05 52 05.5
1	D	240	02	22.4	304	53	01.7	236	18	59.3	6	50	28.5	7.0	36.0	CNCR
	R	60	18	12.3	125	08	53.8	56	41	41.8	6	57	17.0	34.5	05.5	21 10 EST
	MEAN	240	10	17.4	305	00	52.8	236	30	20.6	6	53	52.8	6	48.5	06 52 15.5
2	D	240	06	21.4	304	57	01.5	236	24	21.9	6	51	14.5	7.0	36.0	CNCR
	R	60	14	13.0	125	04	52.0	56	36	59.4	6	58	52.0	34.5	05.6	21 10 EST
	MEAN	240	10	17.2	305	00	56.8	236	30	40.6	6	55	03.2	7	37.5	06 52 15.5
3	D	240	10	22.2	305	00	58.9	236	29	56.0	6	52	37.0	7.0	36.0	CNCR
	R	60	10	13.5	125	00	52.1	56	32	05.5	6	59	42.5	34.6	05.6	21 10 EST
	MEAN	240	10	17.8	305	00	55.5	236	31	60.8	6	56	09.8	7	05.5	06 52 15.5
4	D	240	14	20.9	305	04	59.5	236	35	16.0	6	53	15.8	7.0	36.0	CNCR
	R	60	06	12.5	124	56	53.1	56	27	15.0	7	00	39.0	34.6	5.6	21 10 EST
	MEAN	240	10	16.7	305	00	56.3	236	31	15.5	6	56	57.4	7	23.2	07 17 12.5
5	D	240	18	20.5	305	08	58.8	236	40	36.9	6	53	55.8	7.0	36.0	CNCR
	R	60	02	15.7	124	52	54.3	56	22	18.7	7	01	15.5	34.6	5.6	21 10 EST
	MEAN	240	10	18.1	305	00	56.6	236	31	27.8	6	57	35.6	7	18.8	07 17 12.5

Figure 12

ASTRONOMICAL AZIMUTH FIELD NOTES

SAMPLE COPY

Chapter 5

ANALYSIS

5.1 Observed Angles

The test quadrilateral observations include 4 separate sets of observations with 22 station occupations over a one month period. The angles are summarized in Table 4. The Wild T-3 observations taken in conjunction with the control extension survey make up set number 1. The second set was taken with the DKM-3 using the 5-wire method with three series per station. The third set of observations was made with the DKM-3 using only the center wire and taking 16 series. On the same night that a station was occupied for set three, a second set was observed with the DKM-3 using the 5-wire method. The angles from this method were combined to make set number four.

Out of the 22 station occupations made, 3 were completely rejected and 2 were partially rejected due to poor misclosures. The maximum variation in an observed angle was 3.02 seconds of arc, however, if the rejected observations are excluded, the maximum variation was 1.83 seconds of arc. Refraction on the lines which had station LANE as a terminal caused the highest variations. All of the stations were elevated except LANE, therefore, the lines of sight passed through different heat layers giving rise to considerable

Table 4

SUMMARY LIST OF DIRECTIONS

DATE	INSTR.	No. of D & R	No. of Wires	Instr. Station	Initial	Target	Target	Std. Err. of 1 Obs.
14 Apr.	T-3	16	1	ARENA	0°00'00"00	SISSON	86°25'(46"25)R	± 0"99
17 Apr.	T-3	16	1		00"00		48.54	0.78
27 Apr.	DKM-3	15	5		00.00		48.39	0.47
28 Apr.	DKM-3	10	5		00.00		48.16	0.44
10 May	DKM-3	16	1		00.00		48.46	0.66
10 May	DKM-3	30	5		00.00		48.22	0.61
13 Apr.	T-3	16	1	STADIUM	SISSON	LANE	ARENA	± 0"96
27 Apr.	DKM-3	15	5		0°00'00"00	43°28'49"03	113°10' 02"04	0.68
28 Apr.	DKM-3	15	5		00.00	49.79	(03.50)R	0.64
11 May	DKM-3	16	1		00.00	49.72	02.27	0.68
11 May	DKM-3	25	5		00.00	48.52	01.56	1.02
16 Apr.	T-3	16	1	SISSON	LANE	ARENA	STADIUM	± 0"80
27 Apr.	DKM-3	15	5		0°00'00"00	81°49'01"07	115°55' 11"17	0.96
28 Apr.	DKM-3	15	5		00.00	(04.09)R	(13.60)R	0.68
29 Apr.	DKM-3	15	5		00.00	02.71	12.50	0.68
12 May	DKM-3	16	1		00.00	(03.34)R	(13.46)R	0.98
12 May	DKM-3	20	5		00.00	02.71	12.37	0.84
16 Apr.	T-3	16	1	LANE	ARENA	SISSON	SISSON	± 1"10
17 Apr.	T-3	16	1		0°00'00"00	23°52'(56"81)R	44°28'(56"57)	0.96
28 Apr.	DKM-3	15	5		00.00	58.71	58.61	0.74
13 May	DKM-3	16	1		00.00	59.33	58.65	0.80
13 May	DKM-3	20	5		00.00	58.32	57.58	0.77
						59.13	58.72	

distortion. The residuals from the adjustment of each set of observations are listed in Table 5 with the first three highest values marked for each set. In almost all cases, the highest residuals occur on a line having LANE as a terminal.

A second indication of refraction in the observed angles can be deduced from the graph of angles versus time in Figure 13. Although the amount of data for such an analysis is small, there is a trend for the angles to increase in size after 10:00 PM. This is the period in the evening when the heat differential is a maximum because the earth is losing its heat absorbed through the day back to the air. The period from 7:00 to 9:00 PM proved to be the most stable period of the evening. During this period the earth is not absorbing heat as the sun is setting and it has not begun to lose any heat. These conclusions were also made by L. Simmons [14] when he said:

Experience seemed to prove that the better a light appeared in the telescope, the better were the observing conditions. The problem is just as simple as that. Good appearing lights produced good results. Almost always, everywhere, the lights look the best just after sundown.

The number 3 set of observations were all taken just after sundown in this test and the closures were the smallest obtained.

Errors in the observed angles due to noncentering were discussed in section 3.3 and found to be negligible. Only one case of error from a target not being centered was

Table 5

RESIDUALS

INSTRUMENT DIRECTION	T-3	DKM-3 & 5-wire	DKM-3	DKM-3 & 5-wire
ARENA-STADIUM SISSON LANE	" -.048 (3) .272 -.224	" .105 -.135 .030	" -.037 (2) .026 .010	" .107 .058 -.165
STADIUM-SISSON LANE ARENA	" -.169 (1) .300 -.131	" .310 (3) -.352 .083	" .002 (3) -.034 .032	" .107 .019 -.126
SISSON-LANE ARENA STADIUM	" -.025 (1) .092 .067	" .580 (1) .299 -.281	" .025 (1) -.016 -.008	" .223 (2) -.093 -.131
LANE-ARENA STADIUM SISSON	" -.055 (2) .291 -.236	" .352 (2) -.148 -.204	" -.018 (1) .050 -.032	" .252 (1) .032 (3) -.219
AVERAGE	.159	.240	.024	.128

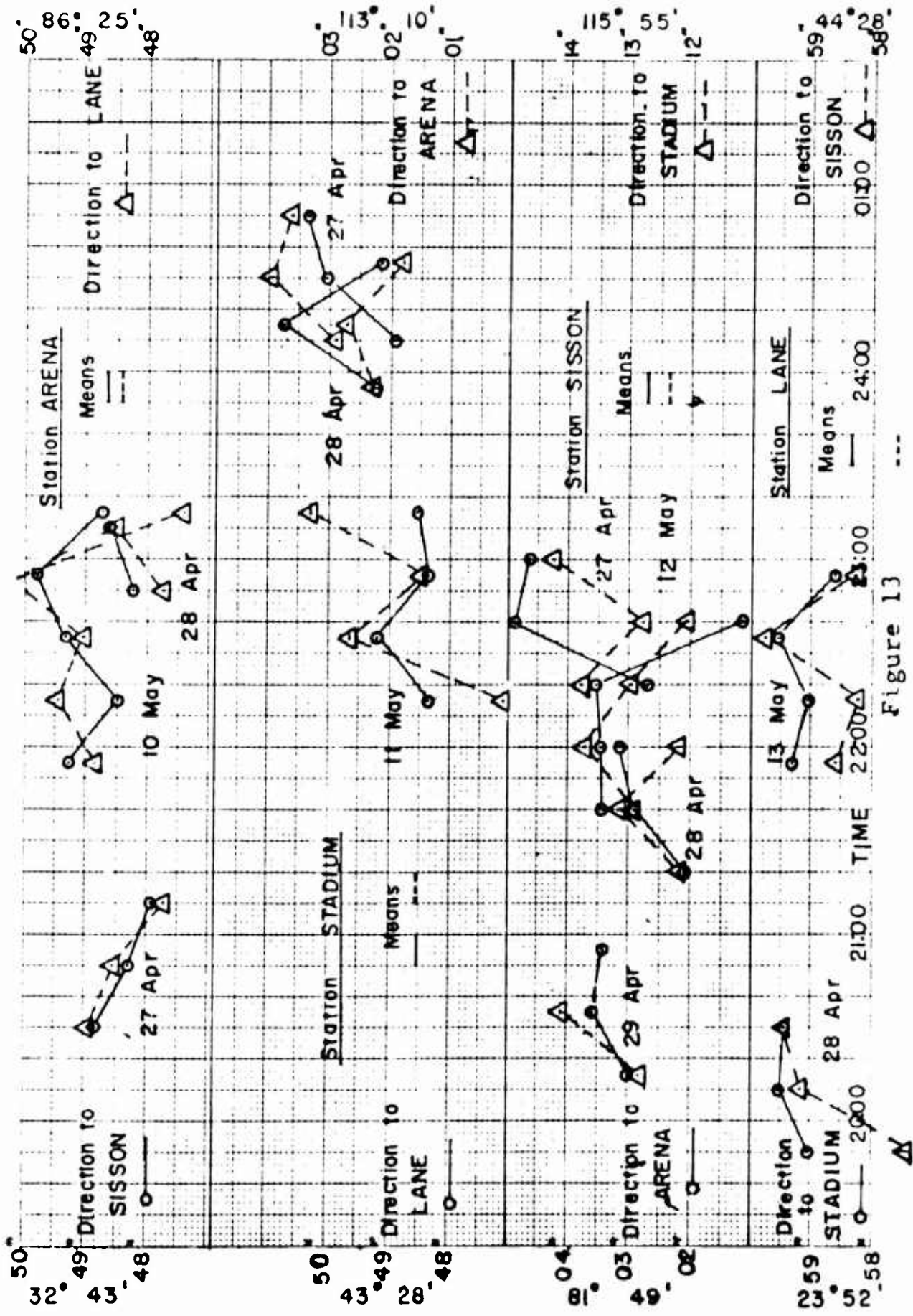

Figure 13

GRAPH OF DIRECTIONS OBSERVED WITH 5-WIRES VERSUS TIME

found, and this was on the ARENA-STADIUM line which was observed on the 14th of April. The stand was checked the next day and found to be approximately 2 millimeters off center . The direction was then reobserved and the value changed by 2 seconds of arc.

The observation errors are controlled only by careful manipulation of the theodolite and centering of the targets on the crosshairs. These errors are minimized by the process of repetition as long as all the systematic errors are extracted. The number of repetitions required by the USC&GS for first order observations are 16. Jordan [6] shows by graphing the equation for the standard error of the mean that very little accuracy is gained by exceeding 10 repetitions, however, this requires observations which include random errors only. This graph is shown in Figure 14 where the standard error of one observation is given the value of unity. At station ARENA, the number of series observed varied from 10 to 30 with no real indication that the angle obtained with 10 pointings was less accurate than the one obtained with 30 pointings. This data is listed in Table 4 on page 33.

5.2 Precision of the Observed Angles

Standard errors for a single direct and reverse direction were computed for every set of observations made and are listed in Table 4 on page 33. These values ranged

from ± 1.10 to ± 0.44 . The main factors in the precision of a direction were the refraction and heat distortion eliminating any possibility of drawing conclusions on the effect of distance and instrumentation on the precision.

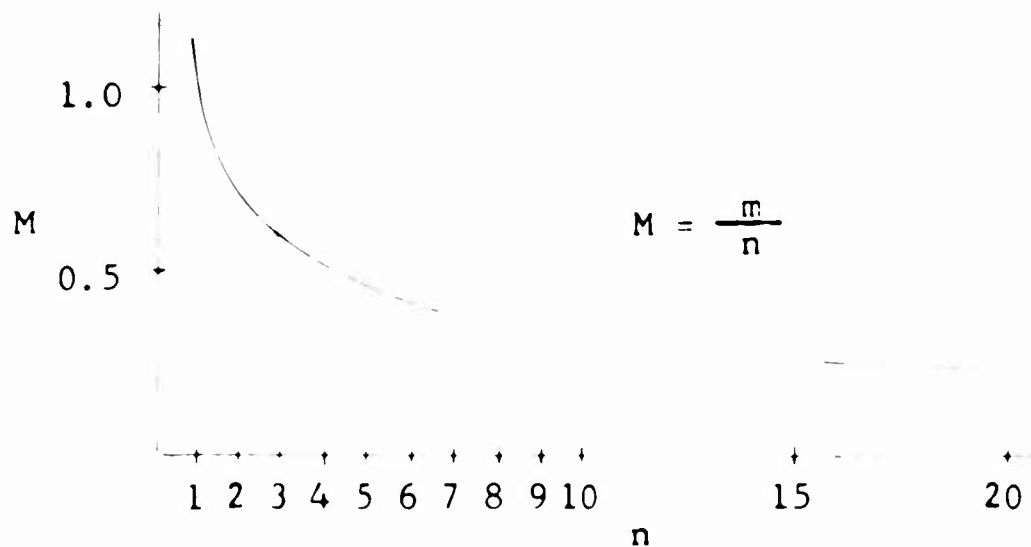

Figure 14

GRAPH OF STANDARD ERROR OF MEAN

A station adjustment was performed on each set of observations at a station according to a system given by Uotila [16]. This adjustment eliminates the problem of a zero initial in the calculation of residuals. The first step is to compute a temporary variance $u = \text{Mean} - \text{Observed Value}$. The u terms are then added algebraically along the horizontal rows and placed in a new column denoted R' . The computation for the residual of a single pointing is now $v_n = u_n - \frac{R'}{s}$ where n is the number for that series and s is the number of targets. After all of the residuals are

computed, they are squared and summed. The formula for the standard error of a single pointing is then $m = \sqrt{\frac{(vv)}{(r-1)(s-1)}}$ where s is the number of targets and r is the total number of series. For example computations, see Table 6 .

To obtain a residual for each direct and reverse pointing in the 5-wire method, the direct and reverse readings for each wire were meaned. The directions were then computed by subtracting the initial target reading from the remaining targets. After obtaining the directions for each wire, the residuals were computed as previously described. The reason for the extensive computations is that a direction is not obtained for each individual pointing as in the single wire case. The standard errors for a single direction are listed in Table 7 for each instrument used in this test.

5.3 Analysis of Short Line Triangulation Data

The observations from each test were first analyzed to see if they met first order specifications, and if not, reobservations were made. After the requirements had been met, the data was adjusted by an electronic computer with an existing program written for the Geodetic Science Department. The method of adjustment was by variation of coordinates. The results of each test quadrilateral are listed in Table 8 . The number of reobservations was relatively small for the good triangle closures obtained. Set number two had 4

Table 6
SAMPLE COMPUTATION OF RESIDUALS

Series No.	Observed Angles			Temporary Variance			Residuals		
	Station: STADIUM	Station: SISSON	Station: ARENA	STADIUM	SISSON	LANE	STADIUM	SISSON	LANE
	0° 00'	32° 43'	86° 25'						
1	00.0	50.1	49.0	0	-1.4	-0.5	0.7	-0.8	0.1
2	00.0	48.7	49.1	0	0.0	-0.6	0.2	0.2	-0.4
3	00.0	47.5	48.3	0	1.2	0.2	-0.4	0.7	-0.3
4	00.0	48.4	48.0	0	0.3	0.5	-0.2	0.0	0.2
5	00.0	50.0	48.9	0	-1.3	-0.4	0.6	-0.7	0.1
6	00.0	49.0	49.5	0	-0.3	-1.0	0.4	0.1	-0.5
7	00.0	48.5	47.7	0	0.2	0.8	-0.3	-0.2	0.5
8	00.0	48.4	49.1	0	0.3	-0.6	0.1	0.4	-0.5
9	00.0	50.4	48.4	0	-1.7	0.1	0.5	-1.1	0.6
10	00.0	49.1	48.6	0	-0.4	-0.1	0.1	-0.2	0.1
11	00.0	48.4	49.4	0	0.3	-0.9	0.2	0.5	-0.7
12	00.0	47.5	45.6	0	1.2	2.9	-1.3	-0.2	1.5
13	00.0	48.7	47.6	0	0.0	0.9	-0.3	-0.3	0.6
14	00.0	47.9	49.0	0	0.8	-0.5	-0.1	0.7	-0.6
15	00.0	48.3	48.4	0	0.4	0.1	-0.2	0.2	0.0
16	00.0	48.0	48.8	0	0.7	-0.3	-0.1	0.6	-0.5
Mean	00.0	48.7	48.5						
									[vw] = 13.02

reobservations, but this was the first set of readings taken with the DKM-3 by the observer.

Table 7
STANDARD ERRORS OF A SINGLE POINTING
FOR EACH THEODOLITE

Instrument	No. of Wires	Standard Error
T-3	1	± 0".94
DKM-3	1	0.79
DKM-3	5	0.73

The average standard error of a single observation determined from the four test adjustments was ± 0.30 seconds of arc. For a line 800 meters long, which was the average length used in this study, the linear error was computed using the angular error of 0.30 seconds and found to be 1.2 millimeters.

5.4 Analysis of Astronomical Azimuth Observations Taken Using 5-Wire Techniques

Because of cloudy weather and limited observing time, only two nights of observations were made. One series of 5-wire readings were made on the first night using the plate level and two series of 5-wire readings were made on a second night using the striding level. The amount of data obtained was insufficient to draw any conclusions on the accuracy of the azimuth, and there was no true value to compare with, but the procedures were outlined and the

Table 8

TRIANGULATION DATA

Test No.	Instr	No. of Wires	Average Triangle Closure "	Maximum Triangle Closure "	Minimum Side Check	m ^o from Adjustment	Maximum Coordinate Std. Error	Minimum Coordinate Std. Error
1	T-3	1	0.28	0.56	1/67,000	+ 0.32	± 8.510	± 8.503
2	DKM-3	5	0.86	1.58	1/82,000	0.55	0.016	0.004
3	DKM-3	1	0.12	0.18	1/738,000	0.05	0.002	0.0004
4	DKM-3	5	0.66	1.01	1/42,000	0.27	0.008	0.002

probable error was within first order requirements.

The ground clearance on the lines to the ground stations was only 3 to 4 feet and heat distortion was very bad during the observations, but only one full set was rejected. This was the number 1 wire reading of the first nights observations. The azimuth for this observation was 6.3 seconds above the mean on NORTH BASE and 6.1 seconds above the mean on LANE. The number 1 wire reading was also high on the second night, but stayed within the 5 second rejection limit. The computed azimuths are summarized in Table 9.

The difference between the mean of the two nights observations was 1.2 seconds on NORTH BASE and 2.3 seconds on LANE, which is good considering the heat distortion. The probable errors of the azimuths to NORTH BASE and LANE were ± 0.27 seconds and ± 0.28 seconds respectively. The results of these observations were encouraging and the method warrants further investigation.

5.5 Analysis of the 5-Wire Angle Observations

The results obtained using the 5-wire method met all first order specifications, but when compared with the results of the single wire observations, they were not as good. The observed angles were consistently high causing high triangle closures which were reflected through the computations. For example, in Table 4 on page 33, the

average observed direction to ARENA from SISSON was $81^{\circ} 49' 03''.28$ as observed with the 5-wire method while the directions obtained using the single wire were $81^{\circ} 49' 02''.71$ and $01''.07$. Also, at station LANE, the average directions to all targets observed with 5 wires were almost 1 second of arc higher than the directions observed with a single wire.

This consistent increase in the observed angles obtained using the 5-wire procedures indicated a systematic error. A possible cause of this error can be detected in the graph of the observed angles in Figure 13 on page 36. In almost all cases the value obtained from the second series was over 1 second higher than the first reading, and although the third series dropped, it did not drop back to the reading obtained on the first series.

The observing procedure used in the field was to always start with the number 1 wire after plunging the instrument. This meant that the motion of the instrument which was counterclockwise as the wires were centered 1 through 5 in the direct position was now clockwise in the reverse position as illustrated in Figure 15a. This type of unsymmetric motion of the theodolite has always been avoided because of systematic errors. For example, if the pointings on the targets are consistently off, the error will be doubled using the adopted sequence.

If the alternate observing procedure which was described in section 4.2 is used, the instrument motion will always be

counterclockwise as the wires are centered as shown in Figure 15b . This procedure gives rise to another systematic error caused by consistent increase of the slow motion screw spring tension.

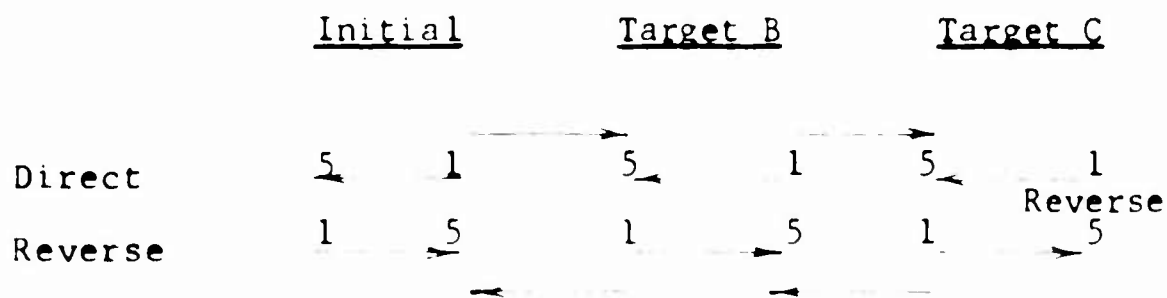

Figure 15a

INSTRUMENT MOTION USING ADOPTED METHOD

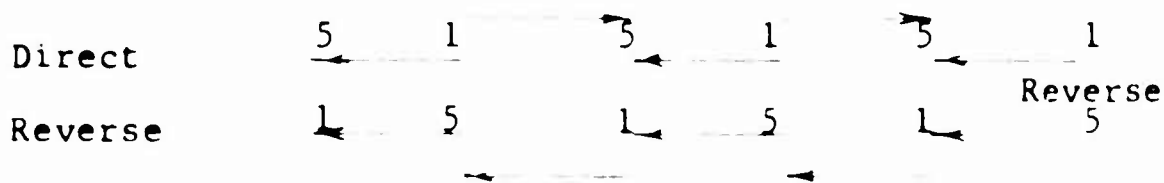

Figure 15b

INSTRUMENT MOTION USING ALTERNATE METHOD

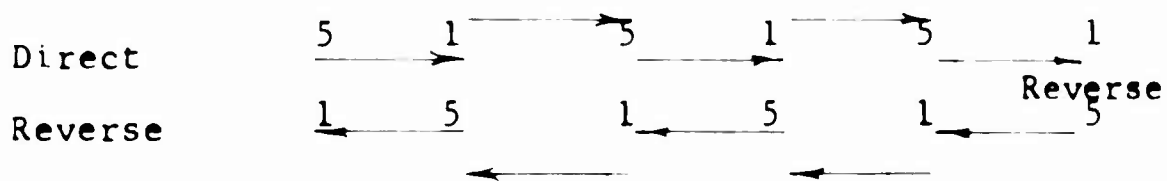

Figure 15c

INSTRUMENT MOTION USING SECOND ALTERNATE MOTION

A second alternate procedure would be to start with the number 5 wire in all cases. (See Figure 15c) This procedure was not tested, but all systematic errors should be minimized as all motions are consistent with accepted

procedures. Instrument motion over the 5 wires is the same as the motion used to move from target to target and the spring tension is of equal intensity in both instrument positions. Therefore any errors caused by the slow motion screw backlash should cancel.

There was not enough time to go back to the test quadrilateral and verify these findings, however, a small test was made using the first two suggested methods on a temporary setup. The instrument was set up on station ASTRO and two series were observed on two targets approximately 500 feet away. An angle of $02^{\circ} 53' 25''.54$ was observed with the method used in the field tests, and a value of $02^{\circ} 53' 24''.76$ was obtained using the alternate procedure. The drop of $0''.48$ was approximately the value of the systematic error observed in the quadrilateral tests. The first method also showed the familiar 0.6 second increase in the second series. The notes and results from this test are shown in Table 10 .

5.6 Accuracy of the 5-Wire Reticule

All observations using the 5-wire method were analyzed to determine the true arc separation of the 5 vertical wires. There were 9 sets of observations excluding those made on the first night when the procedure was being introduced to the observer. The total number of pointings for each wire was 98 in the direct position and 98 in the reverse position.

Table 10

TEST NOTES FOR ALTERNATE METHOD

STA.	1	2	3	1	2	1	2	1	2	1	2	
D	0	38	14.9	240	00	24.5	242	53	51.5	No. 1 wire centered first after reversing the instrument		
	2	12	16.5		08	23.7	243	01	50.2			
	3	08	15.5		12	22.8		05	47.2			
	4	04	17.8		16	21.8		09	45.5			
	5		79.6			117.5			245.6			
R	180	04	24.0	60	16	10.5	63	09	36.5			
	2	08	24.5		12	13.6		05	37.7			
	3	12	26.0		08	13.2		01	40.4			
	4	16	23.5		04	15.5	62	57	41.0			
	5	20	23.7		00	15.7		53	40.4			
Sum												
Dir.	0	12	291.3	60	08	186.0	63	01	441.6			
Ang.	0	00	00.00	0	00	00.00	02	53	25.56	Mean 02° 53' 25".54		
D	0	20	25.0	240	00	33.5	242	54	00.0	No. 5 wire centered first after reversing the instrument		
	2	16	26.5		04	31.5		57	57.6			
	3	12	28.1		08	29.5	243	01	57.1			
	4	08	28.5		12	31.2		05	55.0			
	5	04	28.5		16	27.5		09	54.3			
			136.6			153.2			284.0			
R	180	20	35.0	60	00	24.0	62	53	48.5			
	2	16	36.9		04	20.6		57	46.9			
	3	12	38.5		08	20.0	63	01	47.7			
	4	08	39.5		12	22.0		05	45.0			
	5	04	41.0		16	18.2		09	44.8			
Sum												
Dir.	0	12	327.5	60	08	258.0	63	01	516.9			
Ang.	0	00	00.00	0	00	00.00	02	53	24.89	Mean 02° 53' 24".76		

If the number 2 and 4 wires were not exactly 4 minutes of arc from the number 3 wire, the discrepancy would show in the large quantity of readings. The same discrepancy would show for the number 1 and 5 wires except that they were 8 minutes of arc from the number 3 wire. Residuals for each wire were computed by subtracting the observed value for each wire from the mean of the five readings for that instrument position. This computation gave the number 3 wire a small error, but this was corrected by subtracting the error for wire three from all values giving a 0 error for the middle wire. The residuals for each wire were then meaned to obtain a value for the displacement of that wire from the true center. The mean values of the arc separation are listed in Table 10 for the direct and reverse positions and the mean of the direct and reverse.

This displacement is of no consequence if the readings from the same wire in the direct and reverse positions are always combined for a direction.

Table 11
WIRE DISPLACEMENTS

Wire No.	Direct	Reverse	Mean
1	8' 0.77"	7' 58".98	8' 0.90"
2	4 0.58	3 59.63	4 0.47
3	0 0.00	0 00.00	0 0.00
4	3 59.57	4 0.60	3 59.38
5	7 58.89	8 1.23	7 58.83

Chapter 6

CONCLUSIONS

6.1 Short Line Triangulation Conclusions

This field study has demonstrated that relative positioning of targets can be accomplished accurately with triangulation techniques. Extreme care in observations must be taken and every possible error analyzed. For this reason the procedures are time consuming and laborious, but the accuracy is hard to match by any other means.

The average standard error of an observation after adjustment was ± 0.30 seconds of arc. This figure is close to the peak accuracy that can be attained with the modern glass circle theodolite. For lines 800 meters in length as used in this study, this angular error gives a linear error of 1 millimeter. To obtain a 0.5 millimeter linear accuracy, the lengths of the lines observed could be no longer than 300 meters. The centering becomes more critical also when the accuracies required are increased. To obtain a 0.5 millimeter accuracy in positioning, it is evident that the procedures for centering used in this test would be useless, for the accuracy of centering alone was 0.5 millimeters. Monolith stations would be required along with targets having centering errors less than 0.1 millimeters.

6.2 5-Wire Observation Conclusions

The 5-wire method proved to be a very efficient system for observing directions. The field work done in this test was all on short lines, however, there is no reason why this method could not be used in any direction measuring capacity. The main advantages are speed and ease of manipulation. There is less instrument and observer motion decreasing the possibility of errors due to drag, stand twist, fatigue and accidental bumping. The precision of the directions obtained was the highest of any method, but troublesome refraction and a possible systematic error took away from the accuracy of the final results. The first set of 5-wire observations were also effected by observer inexperience. To eliminate the systematic error, The second alternate method of observing the number 5 wire first always is recommended, but further investigation is needed on this matter.

6.3 Recommended Procedures

Refraction was found to be the main problem in obtaining accurate results. There is no technique for eliminating refraction, therefore, it can only be minimized by careful planning of the observations. It has already been deduced, that the best time to observe was just after sundown, or at sunrise. The experience of this study indicated that this period of stability lasts for only

2 hours depending on the season and the weather.

The number of repetitions taken at a station could be reduced to 10 without loss of accuracy in short line work, once the systematic errors are worked out. This would make total observation time per station including setups of 1 hour. For maximum accuracy, the number of occupations that could be made at one time would be 2. The time required for observation of one quad would be 2 days.

A second procedure which also requires 2 nights work per quadrilateral is to observe each station twice on different nights. The order of observing the stations should be reversed on the second night.

Although the work outlined in these procedures is extensive, this is the only way to guarantee results that are free from systematic refraction errors.

BIBLIOGRAPHY

1. Cook, Jack A. "Establishment of a First Order Triangulation Network at the Ohio State University." M.S. Thesis, The Ohio State University, 1965
2. Egger, K. "Deformation Measurements on Dams." Bulletin 7, Kern & Co. Ltd., Aarau, Switzerland
3. Fondelli, M. "Examination of the Precision of the Kern DKM-3 Theodolites." Research Department, the Military Geographic Institute, Florence, Italy
4. Irish, S.B. "Setup Error In Horizontal Angles." Journal of the Surveying and Mapping Division ASCE, Vol. 85, No. SU1, pp. 1-7, 1959.
5. Jones, P.B. "An Investigation of Systems of Constrained Centering." Survey Review, Vol. XVII. No. 127, pp. 22-34, 1963.
6. Jordan, W., and Eggert, O. Handbuch der Vermessungskunde, Vol. 1, English Translation, Army Map Service, Washington 25, D.C., 1962.
7. Kern & Co. Ltd. "High Precision Measurements." Bulletin 5, Aarau, Switzerland.
8. Kern & Co. Ltd. Precision Measurements Equipments, Aarau Switzerland.
9. Kobold, F. "Measurement of Displacement and Deformation by Geodetic Methods." Journal of the Surveying and Mapping Division ASCE, Vol. 87, No. SU 2, pp.37-66, 1961.
10. Matthias, H. "Autocentering." Surveying and Mapping, Vol. XX, No. 2, pp. 207-215, 1960.
11. Rainsford, H.F. Survey Adjustments and Least Squares, Frederick Ungar Publishing Co., New York, 1958.

12. Reading, Capt. O.S. "Precise Survey of the 25 BEV Synchrotron at Brookhaven National Laboratories." Surveying and Mapping, Vol. XIX, No. 3, pp. 329-336, 1959.
13. Richardson, J.T. "Measuring Structural Behavior of Glen Canyon Dam." Journal of the Surveying and Mapping Division ASCE, Vol. 90, No. SU 2, pp. 133-152, 1964.
14. Simmons, L.G. "A Singular Geodetic Survey." U.S. Coast & Geodetic Survey, Technical Bulletin No. 13, U.S. Government Printing Office, Washington, D.C., 1960.
15. Storms, E. "Geodetic Survey for Telstar Tracking System." Surveying and Mapping, Vol. XXIII, No. 1, pp. 73-78, 1963.
16. Uotila, U.A., Lecture Notes, Adjustments. The Ohio State University, Columbus, 1964.
17. U.S. Department of Commerce, Manual of Geodetic Triangulation, Special Publication No. 247, U.S. Government Printing Office, Washington, D.C., 1959.