

AD618687

✓



COPY _____	OF _____	1/2
HARD COPY	\$.	1.00
MICROFICHE	\$.	0.50

20-p

AUG 8 1965

تسليم
TISA B

AN EXPERIMENTAL STUDY OF
HIGH VELOCITY IMPACT AT NORMAL AND
OBLIQUE INCIDENCE ON MULTIPLE, SPACED
2024-T3 ALUMINUM PLATES

GENERAL MODEL

JUNE 1965
DOUGLAS REPORT SM-47873

MISSILE & SPACE SYSTEMS DIVISION
DOUGLAS AIRCRAFT COMPANY, INC.
SANTA MONICA/CALIFORNIA



PROCESSING COPY

ARCHIVE COPY

**AN EXPERIMENTAL STUDY OF
HIGH VELOCITY IMPACT AT NORMAL AND
OBLIQUE INCIDENCE ON MULTIPLE, SPACED
2024-T3 ALUMINUM PLATES**

GENERAL MODEL

**JUNE 1965
DOUGLAS REPORT SM-47873**

D. P. Mickey
PREPARED BY: D.P. MICKEY

H. H. Dixon
**APPROVED BY: H.H. DIXON,
CHIEF ENGINEER, ADVANCE
STRUCTURES & MECH. DEPT.
RESEARCH AND DEVELOPMENT**

DOUGLAS MISSILE & SPACE SYSTEMS DIVISION

AN EXPERIMENTAL STUDY OF HIGH VELOCITY
IMPACT AT NORMAL AND OBLIQUE INCIDENCE ON
MULTIPLE, SPACED 2024-T3 ALUMINUM PLATES

Prepared under the sponsorship of the
Douglas Aircraft Company Independent
Research and Development Program. Account
Numbers 81211-032/55609 and 80391-015/54527

CONTENTS

ABSTRACT	iii
INTRODUCTION	1
EXPERIMENTAL PROCEDURE	1
RESULTS AND DISCUSSION	2
REFERENCES	5
TABLE I	6
FIGURES	7

AN EXPERIMENTAL STUDY OF HIGH VELOCITY IMPACT AT NORMAL
AND OBLIQUE INCIDENCE ON MULTIPLE,
SPACED 2024-T3 ALUMINUM PLATES

General Model

by

D. P. Hickey

ABSTRACT

An experimental investigation was made of projectile impact on multiple, spaced 2024-T3 aluminum plates at incident projectile velocities on the order of 13,000 ft./sec. The leading plate was either 1/4 in. or 1/16 in. in thickness, with succeeding plates of 1/8 in. in thickness. The spacing between plates was 1-3/4 in. (measured normal to the front plate from the back of the front plate to the front of the following plate). Projectile impact occurred at normal (0°) and oblique (60°) incidence. The projectiles were solid copper and annealed steel spheres of 3/16 in. nominal diameter. The results obtained showed that no more than two plates were completely penetrated. For normal impact, it was found that the hole diameter could be predicted from existing empirical relations.¹

¹Since the completion of this work, a related publication has been issued-- R. L. Warnica and J. W. Gehring, Hypervelocity Impact Experiments (U), General Motors Defense Research Laboratories, ATL-TR-64-83, AD-356903, December 1964 (C).

INTRODUCTION

This report describes experiments which were performed as part of a classified study (Reference 1) associated with determining the feasibility of a follow-through type of projectile capable of damaging spaced multiplate structures.

EXPERIMENTAL PROCEDURE

The Douglas Aerophysics Laboratory two-stage light gas gun (cf. Reference 2) was used in the experiments. This gun is a deformable piston type and is shown schematically in Figure 1. The piston is propelled by a powder charge which subsequently compresses a quantity of hydrogen gas contained in the chamber ahead of the piston. The compressed hydrogen gas then drives a sabot in which the model or projectile is mounted. The sabot, upon leaving the gun barrel, is aerodynamically separated into two parts, which are subsequently diverted away from the test area.

The projectiles used were solid copper and steel spheres with a nominal diameter of 3/16 in. for both types.

The target was comprised of several plates of 2024-T3 aluminum spaced 1-3/4 in. (measured normal to the front plate from the back of the front plate to the front of the following plate) apart. The leading plate was either 1/4 or 1/16 in. in thickness with succeeding plates of 1/8 in. in thickness. The 2024-T3 aluminum was chosen as the target material to allow for comparison to other work, particularly that of References 3, 4, 5 and 6. The plate thicknesses and spacing were established for the purpose of obtaining design information in connection with another study. For the oblique impact case, the target can be considered to be rotated 60° from the normal (i. e., approaches a glancing impact case).

Diagnostic coverage included velocity measurements of the projectile prior to impact and X-ray photographs of the projectile prior to impact and the regions between the plates at various times after impact with the front plate. Determination of the projectile velocity was made by measuring the relative times at which the projectile passed three phototube stations. From the phototube outputs, the impact velocity was determined by extrapolating the average velocities obtained between phototube stations to the target region. The X-ray photographs were obtained using a Field Emission Corporation Model 7360 four-channel flash X-ray system. The system used one 300 kv X-ray tube, three 105 kv X-ray tubes and variable time delay units to fire each tube in a prescribed sequence. All tubes were located above the target region. The 300 kv tube was used to determine the integrity of the model prior to impact. The X-ray tubes were fired in sequence, with the phototube at the last velocity measuring station being used to initiate the sequence.

RESULTS AND DISCUSSION

The results are summarized in Table I and shown photographically in Figures 2 through 5. This series of experiments shows that no more than two plates were penetrated completely. Figures 6, 7 and 8 are flash X-ray photographs obtained from runs 18, 22 and 25, respectively. Examination of Figure 7 shows that most of the spray ejected from the thick front plate was nearly normal to the plate with a small portion continuing in the original direction of the projectile path. Figure 8 indicates that most of the spray ejected from the thin front plate was in the direction of the projectile path with a small amount continuing at an angle more toward a normal direction to the plate. It can be concluded from these results that the spray direction is dependent on the plate thickness for a given projectile diameter, incident velocity, and obliquity. The effect of the incident projectile velocity on the spray angle for a given projectile diameter, plate thickness, and obliquity is given in Reference 6. This reference shows that the spray at lower velocities (10,000 ft./sec. for glass spheres impacting 2024-T3 aluminum plate at 45° obliquity) is primarily along the direction of the incident projectile with a small amount going in a direction toward the normal to the front plate. The spray at higher velocities (19,000 ft./sec. for glass spheres impacting 2024-T3

aluminum plate at 45° obliquity) is primarily in a direction normal to the front plate with a small amount continuing along the path of the incident projectile.

It is of interest to compare the front plate hole diameters with the predicted values obtained from Reference 4. Reference 4 postulates a general relation for the front plate hole diameter relative to the projectile (sphere) diameter for normal impact as

$$D/d = Av_o f(t_s/d) + B \tag{1}$$

which for aluminum projectiles and 2024-T3 aluminum plates becomes

$$D/d = 0.45v_o(t_s/d)^{2/3} + 0.90 \tag{2}$$

with a possible better form as

$$D/d = 2.4(v_o/c)(t_s/d)^{2/3} + 0.90 \tag{3}$$

where

- A a constant, sec./km
- B a constant, non-dimensional
- c velocity of sound in target, km/sec.
- d projectile (sphere) diameter
- D hole diameter
- f() a function of
- t_s shield or front plate thickness
- v_o projectile velocity, km/sec.

This relationship appears to be valid for a variety of projectile to target density ratios in which the projectile density is held constant and the target material varied as was done in Reference 4 to determine the numerical constants. This indicates that the projectile to target density ratio is relatively unimportant which is somewhat at variance with the empirical relations used for impacts on semi-infinite targets (Reference 7) which include the density ratio. It is possible to compare the experimental results for the copper sphere

($t_s/d = 1.33$, run 18) and the steel sphere ($t_s/d = 1.33$, run 29) at normal impact with the predicted values obtained from Equation 2. This Equation gives a value for the hole diameter of 0.58 in. for the conditions of run 18 while the experimental value was 0.80 in. For the conditions of run 29, the predicted and experimental values for the hole diameter were 0.57 in. and 0.60 in., respectively. It developed that run 18 produced the largest hole diameter of a number of similar runs which are not reported because of incomplete measurements. The hole diameters on runs similar to run 18 varied from 0.65 to 0.75 in. This suggests that Equation 2 may be more accurate than the result of run 18 indicates, and that the projectile to target density ratio may not be important in thin-plate impact.

The case of oblique impact is also of interest. It can be seen in comparing the thick plate ($t_s/d = 1.33$, run 22) and the thin plate ($t_s/d = 0.33$, run 25) impacts that the plate thickness influences the ellipticity of the resulting hole with the thin plate tending to be more elliptic. It is desirable to establish whether Equation 2 can be applied to the oblique impact case. Because the resulting holes are elliptic in oblique impact and depend on the target thickness relative to the projectile diameter, it is desirable to compare the hole area to projected area of the projectile rather than to some dimension such as the major or minor axes. This relationship can be obtained by squaring Equation 2 and gives

$$S/s = 0.2025v_o^2(t_s/d)^{4/3} + 0.81 \left[v_o(t_s/d)^{2/3} + 1 \right] \quad (4)$$

where s is the projected area of the projectile and S is the resulting hole area. If one postulates, in analogy to the semi-infinite target case (cf. Reference 7), that for oblique impact on thin plates, the normal velocity component should be used in Equation 4 the area ratio for the thick plate (run 22) and the thin plate (run 25) would be 3.98 and 3.50, respectively. Experimentally the values were 15.53 and 8.64 for the thick plate and thin plate, respectively, assuming the resulting holes were perfect ellipses. The fact that the area ratio for the thick plate (run 22) impact of 15.53 is close to that obtained from normal impact (run 18) on the same plate thickness, which was 18.2, might be construed as indicating that obliquity has a small effect. That this is not true can be shown by comparing the calculated value from Equation 4 with the

thin front plate case of run 25. The calculated value for the area ratio at normal impact is 3.13, while the experimental value for oblique impact (run 25) is 8.64. It is concluded that Equation 4 cannot apply to oblique impact.

REFERENCES

1. D. P. Hickey. A Study of Present Devices and Techniques with Possible Application into Non-Nuclear Directed Energy Weapons (U). Douglas Aircraft Company Report SM-47704, to be published (SRD).
2. W. B. Covey and W. A. Stolzenburg. The Light-Gas Gun/Ballistic Range; Facility Description and Expected Performance. Douglas Aircraft Company Report SM-43057, July 1963.
3. D. J. Maiden, J. W. Gehring and A. R. McMillan. Semiannual Report, Investigation of Fundamental Mechanism of Damage to Thin Targets by Hypervelocity Projectiles. General Motors Corp. Defense Research Laboratories Report TR 63-208, March 1963 (U).
4. C. J. Maiden, J. W. Gehring and A. R. McMillan. Final Report on Investigation of Fundamental Mechanism of Damage to Thin Targets by Hypervelocity Projectiles. General Motors Corp. Defense Research Laboratories Report TR 63-225, September 1963 (U).
5. C. R. Nysmith and J. L. Summers. Preliminary Investigation of Impact on Multiple-Sheet Structures and an Evaluation of the Meteoroid Hazard to Space Vehicles. NASA TN D-1039, September 1961 (U).
6. C. R. Nysmith and J. L. Summers. An Experimental Investigation of the Impact Resistance of Double-Sheet Structures at Velocities to 24,000 Feet per Second. NASA TN D-1431, October 1962 (U).
7. J. L. Summers. Investigation of High Speed Impact: Regions of Impact and Impact at Oblique Angles. NASA TN D-94, 1959 (U).

Table I
TEST DESCRIPTION

<u>Run No.</u>	<u>Projectile</u>	<u>Projectile Weight (gm)</u>	<u>Obliquity</u>
18	3/16 in. dia. solid Cu sphere	0.504	0°
22	3/16 in. dia. solid Cu sphere	0.48	60°
25	3/16 in. dia. solid Cu sphere	0.48	60°
29	3/16 in. dia. annealed steel sphere	0.442	0°

<u>Run No.</u>	<u>Impact Velocity (ft./sec.)</u>	<u>Leading Plate Thickness (in.)</u>	<u>Second Plate Thickness (in.)</u>	<u>Ambient Pressure at Target (mm. Hg.)</u>
18	13,570	0.250	0.125	60
22	13,570	0.250	0.125	60
25	13,270	0.063	0.125	59
29	12,990	0.250	0.125	60

<u>Run No.</u>	<u>No. of Plates Penetrated</u>	<u>Front Plate Hole Dimensions (in.)</u>	<u>Second Plate Hole Dimensions (in.)</u>	
			<u>Min.</u>	<u>Max.</u>
18	2	0.80	0.85	1.20
22	1	0.6-0.9 (elliptical)	0.8-1.1	1.45
25	2	0.40-0.75 (elliptical)	0.15-0.20	0.40-0.90
29	2	0.60	0.95	1.1

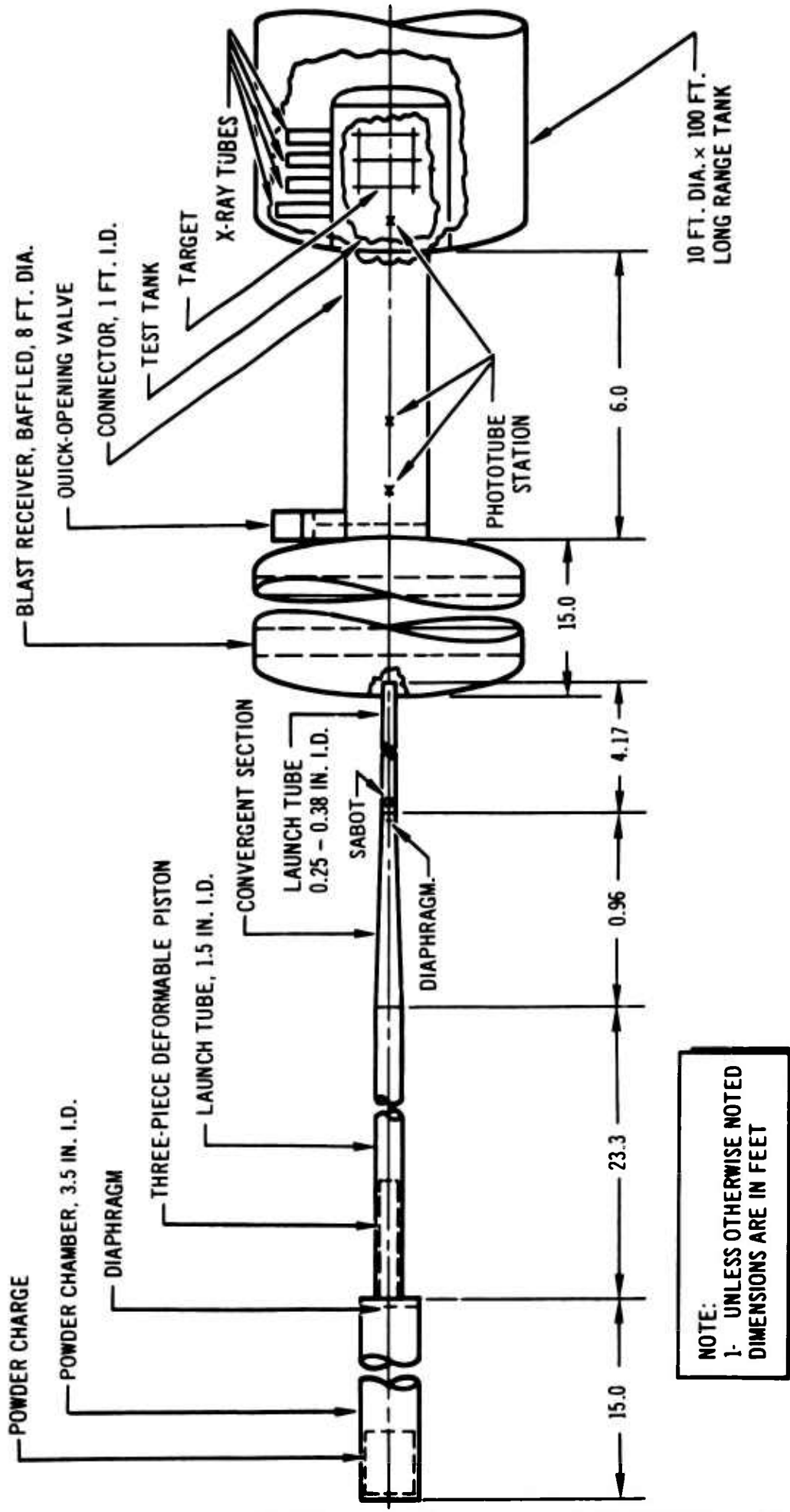

Figure 1 Douglas Aerophysics Laboratory Light Gas Gun and Ballistic Range (Schematic)

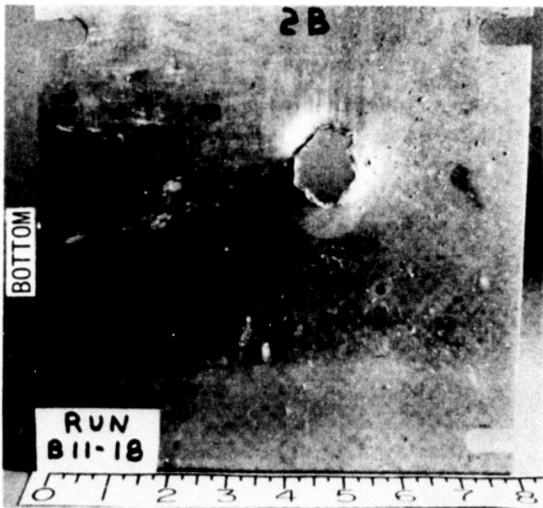
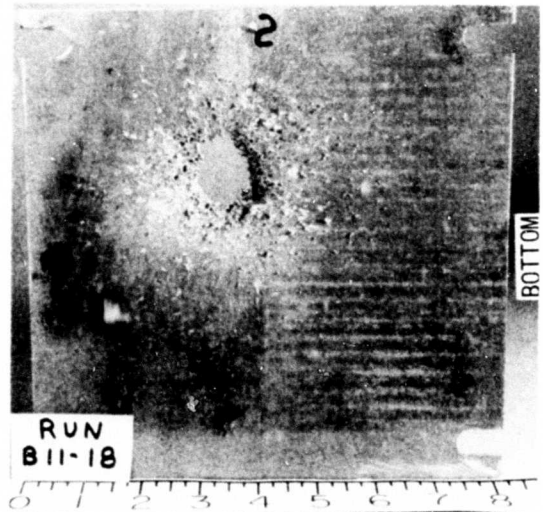
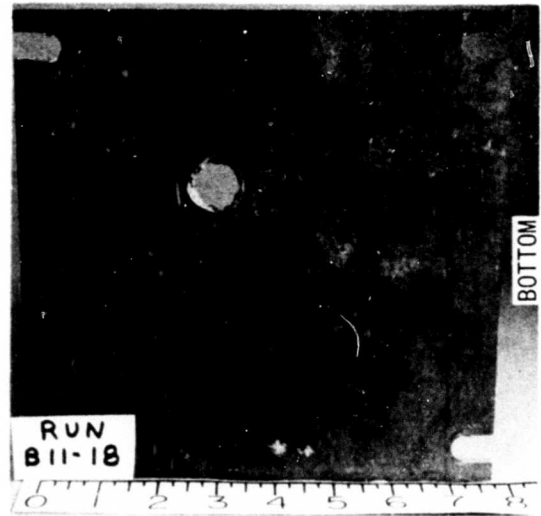
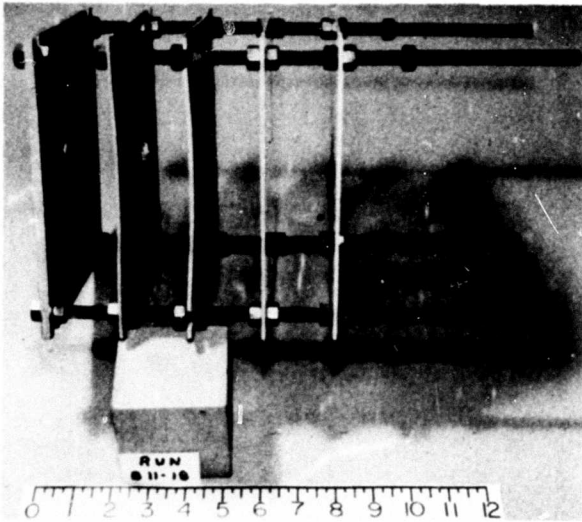

Figure 2 Run 18, 3/16 Inch Diameter Solid Copper Sphere, Normal Impact at 13,570 Feet/Sec.

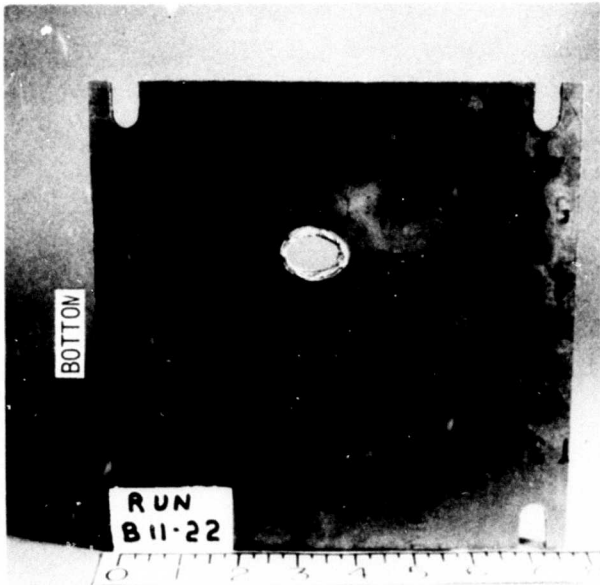
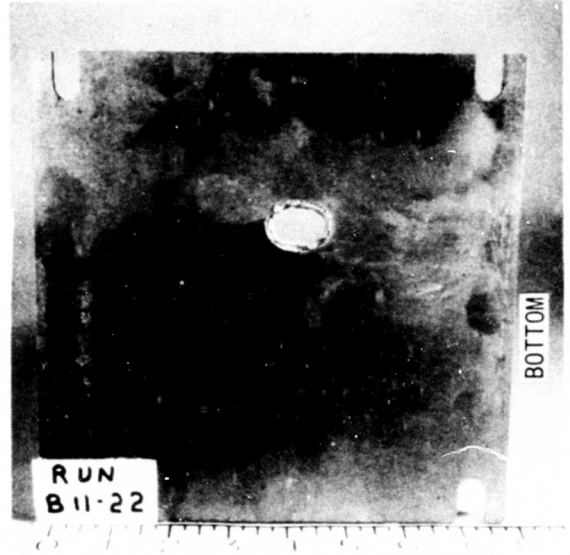
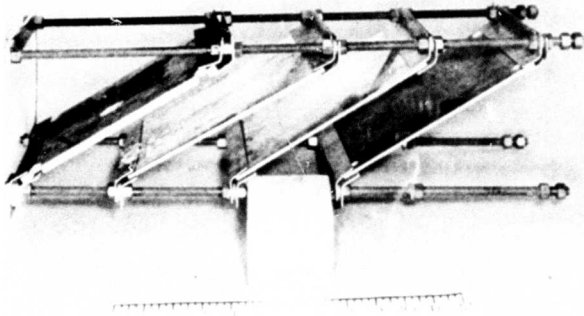

Figure 3 Run 22, 3/16 Inch Diameter Solid Copper Sphere, Oblique Impact at 13,570 Feet/Sec.

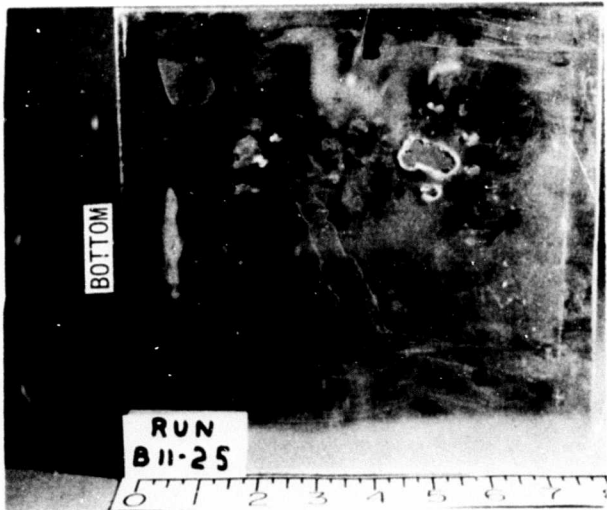
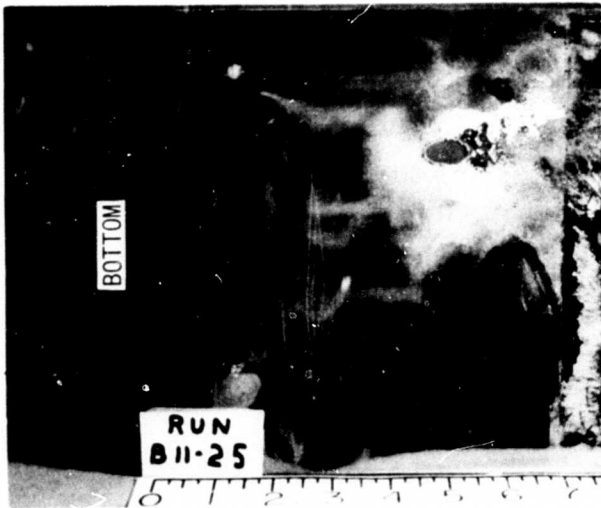
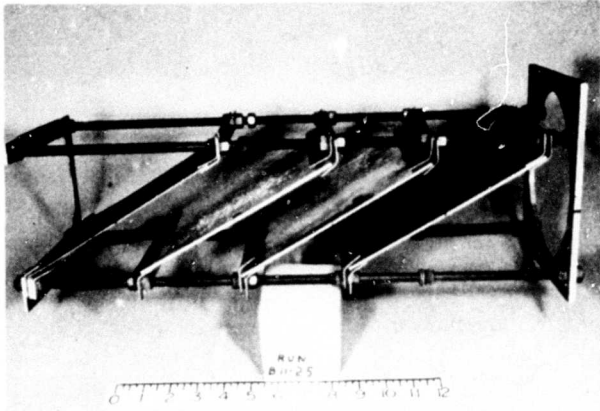

Figure 4 Run 25, 3/16 Inch Diameter Solid Copper Sphere, Oblique Impact at 13,270 Feet/Sec.)

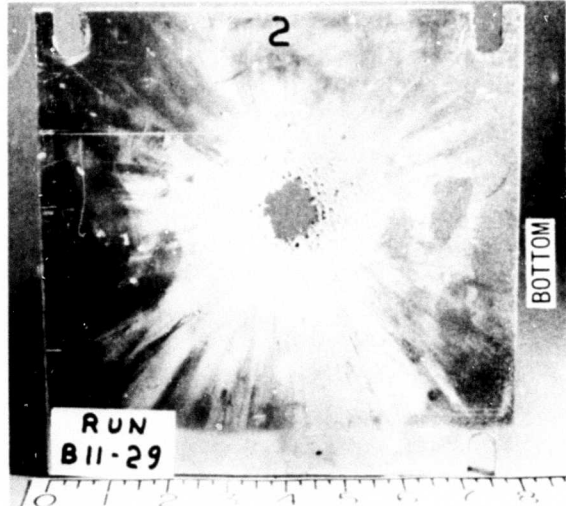
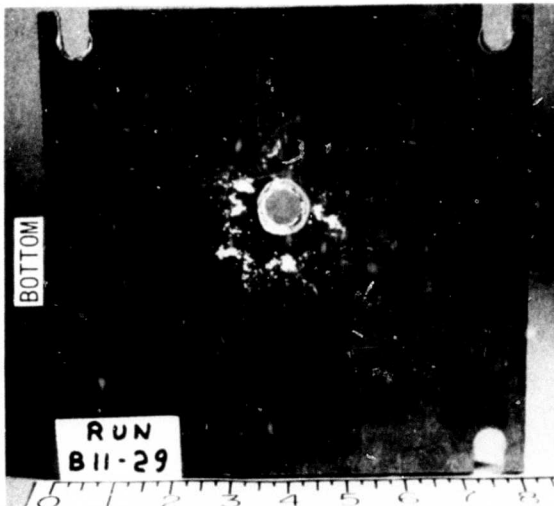
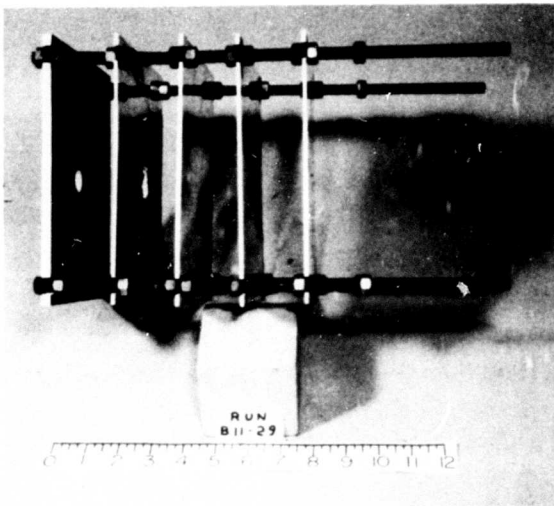

Figure 5 Run 29, 3/16 Inch Diameter Solid Annealed Steel Sphere, Normal Impact at 12,990 Feet/Sec.

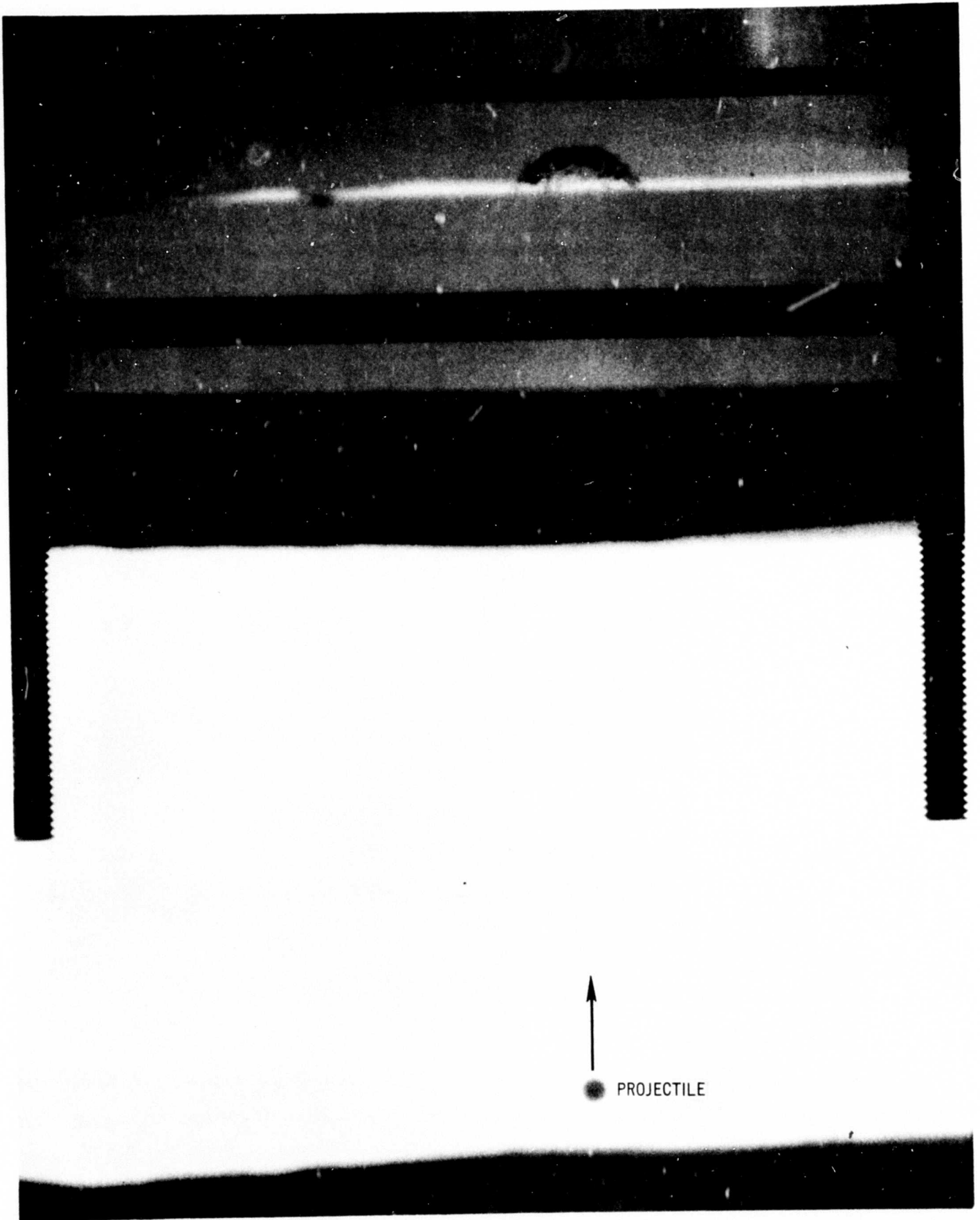

Figure 6 Flash X-Ray of Run 18

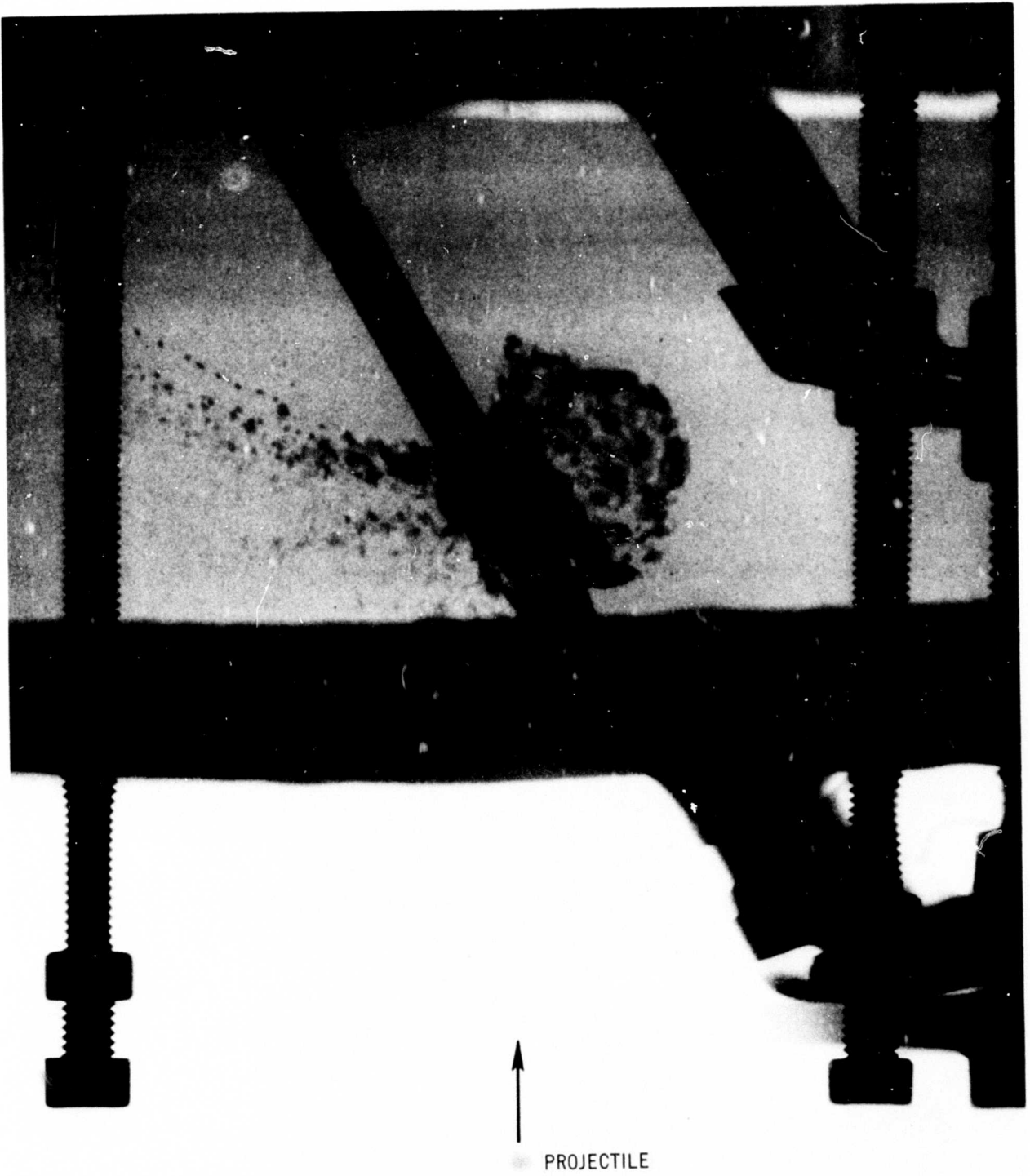

Figure 7 Flash X-Ray of Run 22



PROJECTILE

Figure 8 Flash X-Ray of Run 25