

AD618500

MEMORANDUM

RM-4578-ARPA

JUNE 1965

SOME ASPECTS OF THE DETECTABILITY OF BROADBAND SONAR SIGNALS BY NONDIRECTIONAL PASSIVE HYDROPHONES

F. B. Tuteur

COPY	70-8
100	90
3.00	
0.75	

PREPARED FOR:

ADVANCED RESEARCH PROJECTS AGENCY

D. C. ...
 AUG 6 1965
 ...

The **RAND** Corporation
 SANTA MONICA • CALIFORNIA

ARCHIVE COPY

MEMORANDUM
RM-4578-ARPA
JUNE 1965

SOME ASPECTS OF THE DETECTABILITY OF
BROADBAND SONAR SIGNALS BY
NONDIRECTIONAL PASSIVE HYDROPHONES

F.B. Tuteur

This research is supported by the Advanced Research Projects Agency under Contract No. SD-79. Any views or conclusions contained in this Memorandum should not be interpreted as representing the official opinion or policy of ARPA.

DDC AVAILABILITY NOTICE

Qualified requesters may obtain copies of this report from the Defense Documentation Center (DDC).

Approved for OIS release

PREFACE

In conjunction with RAND's study of Defense Against Submarine-Launched Ballistic Missiles for the Advanced Research Projects Agency, background investigations of theoretical methods for calculating the performance of nondirectional passive sonobuoys are being conducted. This particular investigation is directed toward detecting broadband signals which might be generated by certain types of submarines.

The author is an Associate Professor in the Department of Engineering and Applied Science, Yale University, and is a consultant to The RAND Corporation.

SUMMARY

This Memorandum deals with some of the problems arising in the passive detection of submarines by single, nondirectional hydrophones. The signal emitted by the submarine is assumed to be a broadband noise whose characteristics are similar to those of the background noise. Hence, detection is possible primarily because of the increase in noise power caused by the presence of a target. The effects of the motion of the submarine past the hydrophone and of the uncertainty in the background noise level are analyzed. Although the observation time for a slowly moving submarine is greater than that for a fast submarine, it is found that if there is uncertainty about the background noise level, detectability is essentially independent of observation time. Hence, a faster and therefore noisier submarine is more easily detected than a slower and quieter one. The major factor limiting the detection range is the noise uncertainty; but if the background noise is stationary, the fact that the signal produced by the moving target is a nonstationary noise can be used by the detector to estimate the background noise, and therefore to increase the detectability.

ACKNOWLEDGMENTS

The author wishes to express his appreciation to I. S. Blumenthal for the many helpful and stimulating discussions that served to clarify the direction of this work. He is also indebted to M. Blum and I. Selin for their many helpful and constructive comments.

CONTENTS

PREFACE	iii
SUMMARY	v
ACKNOWLEDGMENTS	vii
LIST OF FIGURES	xi
LIST OF SYMBOLS	xiii
Section	
I. INTRODUCTION	1
II. OPTIMUM DETECTOR FOR DETECTING A MOVING TARGET IN A NOISE BACKGROUND HAVING KNOWN STATISTICAL PROPERTIES	3
III. SIMPLE SUBOPTIMUM DETECTOR FOR DETECTING A MOVING TARGET IN NOISE WITH KNOWN STATISTICS	10
IV. EFFECT OF PRACTICAL SIGNAL AND NOISE SPECTRA	14
V. EFFECT OF UNKNOWN NOISE LEVEL	23
VI. UNCERTAINTY OF NOISE LEVEL DESCRIBABLE BY A GAUSSIAN PROBABILITY DENSITY FUNCTION	38
VII. CONCLUSIONS	44
Appendix	
A. LIKELIHOOD RATIO FOR DETECTION OF A GAUSSIAN SIGNAL IN GAUSSIAN NOISE BACKGROUND	48
B. DETECTION WHEN SIGNAL OR NOISE POWER IS UNKNOWN	57
REFERENCES	60

LIST OF FIGURES

1.	Target and sonobuoy geometry	3
2.	Likelihood ratio detector	9
3.	Detection indices for optimum and suboptimum detectors	13
4.	Optimum detector	16
5.	Example spectral densities for target and for noise	19
6.	Detector output versus time	23
7.	Minimax range versus uncertainty in noise level	27
8.	Minimax range versus noise uncertainty	28
9.	Detection probability versus range	31
10.	Minimax range versus uncertainty in noise level for 8 db per distance doubled transmission loss	33
11.	Minimax range versus noise uncertainty for 8 db per distance doubled transmission loss	34
12.	Transmission loss function and resulting detection probability	
13.	Detection range versus σ_N	40
14.	Average detection probability versus range	41
15.	Average detection probability versus range for arbitrary transmission-loss function $g(h/k)$ and Gaussian noise-level uncertainty	43

LIST OF SYMBOLS

a_{ij}	general matrix element
a_k, b_k	coefficients of Fourier expansion
d	detection index, output signal-to-noise ratio
f	frequency
$f(t)$	modulating function
$G(f)$	spectral density
$g\left(\frac{h}{k}\right)$	transmission-loss function
$H(\omega)$	filter transfer function
h	minimum range between target and buoy
h_m	minimax range
h_d	detection range
\bar{h}_d	average detection range
\mathbf{I}	identity matrix
k	standard distance used in the definition of target signal level
K_α	argument of false-alarm probability
\bar{K}_α	argument of average false-alarm probability
N	noise power
N_0	nominal zero frequency noise spectral level
N_1	actual zero frequency noise spectral level
N_{\min}	minimum zero frequency noise spectral level
N_{\max}	maximum zero frequency noise spectral level
$n(t)$	noise

$N(\omega)$	normalized noise power spectral density
\underline{P}	target signal covariance matrix
\underline{p}	normalized target signal covariance matrix
$p(N_1)$	probability density function of N_1
$p_0(U)$	conditional probability density function of U when noise only is present
$p_1(U)$	conditional probability density function of U when signal and noise are present
$P(D)$	probability of detection
$P(\bar{D})$	average probability of detection
Q	noise covariance matrix
q	normalized noise covariance matrix
S_0	zero frequency target signal spectral level at receiver
S_1	zero frequency target signal spectral level at a standard distance (usually one yard) from target
S	target signal power
$S(\omega)$	target signal normalized spectral density
$s(t)$	target signal
T	observation time
tr	trace
U	test statistic (output of likelihood ratio receiver)
U_0	test threshold
u	normalized test statistic
u_0	threshold of normalized test statistic
v	target velocity
W	bandwidth

$x(t)$	received signal
\underline{X}	received signal sample vector
$y(t)$	unmodulated target signal
\underline{Y}	sample vector corresponding to $y(t)$
Z_{α}	argument of false-alarm probability
$Z_{\bar{\alpha}}$	argument of average false-alarm probability
Z_{β}	argument of miss probability
$Z_{\bar{\beta}}$	argument of average miss probability
α	conditional false-alarm probability
$\bar{\alpha}$	averaged conditional false-alarm probability
β	conditional miss probability
$\bar{\beta}$	averaged conditional miss probability
Δt	time increment between samples
ΔN_0	maximum deviation of noise level from nominal value
θ	angle between line-of-sight and target path
\oplus	error integral
μ_1	mean value of detector output given that signal is present
μ_0	mean value of detector output given that signal is absent
σ_0	standard deviation of detector output if noise only is present
σ_1	standard deviation of detector output if signal and noise are present
σ_N	standard deviation of noise level
φ_n	random phase angle
ω_0	break frequency in target signal spectrum

ω_1	lower break frequency in noise spectrum
ω_2	upper break frequency in noise spectrum
ω_n	sample frequency

I. INTRODUCTION

The sound emitted by a submarine is assumed to consist of a number of line frequencies in the lower-frequency part of the signal band and a broadband, stochastic type of signal over most of the higher-frequency band. In this Memorandum, detection based on the broadband component of signal is considered. For certain submarines the amplitude of the line components may be very low and their effect on detectability is therefore small. Also, the line components and broadband components are probably additive in their effect on detectability, and they can, therefore, be considered separately. Finally, by considering only the broadband spectrum, a somewhat pessimistic result is obtained which can be improved by processing the line components in an optimum fashion.

This analysis is preliminary in nature and its purpose is to provide rough order-of-magnitude estimates of detectability. It is based, therefore, on a number of simplifying assumptions concerning the nature of the target signal, background noise, and transmission loss. Specifically, it is assumed that both the noise and the signal measured at the target have a Gaussian amplitude distribution with zero mean and known spectral shape (although not necessarily known spectral level) and that they are stationary. For most of the analysis, the transmission loss is assumed to be inversely proportional to the square of the distance between source and receiver; however, other transmission-loss curves are briefly considered. Any effect of the transmission medium on the spectral shape of the signal is ignored.

The target submarine is assumed to travel along a straight line at constant velocity, and it is assumed that this velocity is slow enough so that Doppler shifts are of negligible importance, at least to the broadband detection system.

With these assumptions, the detection problem is the problem of detecting a Gaussian signal in a Gaussian noise background. This problem has been studied extensively, (Ref. 1, Chaps. 18-20, and Ref. 2, Chap. XI) and the pertinent results are presented in Appendix A.

**II. OPTIMUM DETECTOR FOR DETECTING A MOVING TARGET IN A NOISE
BACKGROUND HAVING KNOWN STATISTICAL PROPERTIES**

The signal received by the sonobuoy is given by

$$x(t) = s(t) + n(t) \quad (1)$$

where $s(t)$ is the signal that would be observed if there were no noise, and $n(t)$ is the noise. In the present case, where a target submarine is assumed to travel past the buoy, the signal is amplitude modulated and is therefore in the form

$$s(t) = f(t) y(t) \quad (2)$$

where $y(t)$ is a stationary (i.e., unmodulated) stochastic signal and $f(t)$ is the deterministic dimensionless amplitude modulation resulting from the change in transmission loss. For the geometrical situation shown in Fig. 1, and if the signal power is inversely proportional to the square of the distance,

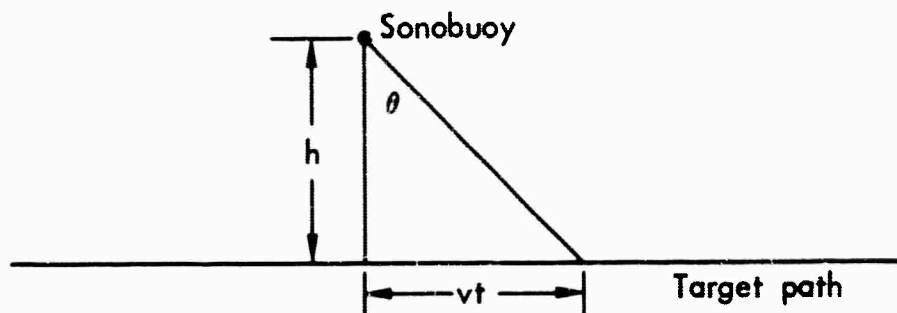

Fig. 1—Target and sonobuoy geometry

$$f^2(t) = \frac{k^2}{h^2 + (vt)^2} \quad (3)$$

where k is a constant of proportionality, h is the minimum distance from the target to the receiver, and v is the target velocity. The time $t = 0$ is arbitrarily chosen as the time at which the target-buoy distance is a minimum.

A nonstationary signal of the type given in Eq. (2) is most conveniently expressed in terms of time samples. Thus, the received signal $x(t)$ is represented by an n -dimensional vector

$$\underline{X}' = [x(t_1), x(t_2), \dots, x(t_n)] \quad (4)$$

where the prime indicates matrix transposition. According to the sampling theorem,* if the signal bandwidth is W cps, samples taken at time intervals separated by $\frac{1}{2W}$ seconds represent the signal completely except near the ends of the observation interval, where sampling introduces a small error. For an observation interval of T seconds the dimension, n , of the sample vector \underline{X} is therefore approximately $2TW$.

The optimum detector is known to be a likelihood-ratio detector which decides between the presence or absence of the target by computing the likelihood ratio corresponding to the received signal and comparing it with a preset threshold. The decision that a target is present is made if the threshold is exceeded. The threshold is normally adjusted to provide a specified false-alarm rate, and it can therefore be regarded as a function of the false-alarm rate.

* See Ref. 1, Section 4.2.

In the following discussion it is assumed that the background noise level is precisely known. It is shown in Appendix A that for small signal-to-noise ratio the likelihood-ratio receiver is equivalent to a device that computes the test statistic

$$U = \frac{1}{2} \underline{X}' \underline{Q}^{-1} \underline{P} \underline{Q}^{-1} \underline{X} \quad (5)$$

where \underline{Q} and \underline{P} are covariance matrices of \underline{X} corresponding to noise only present and to signal only present respectively, i.e.

$$\underline{Q} = \langle \underline{X} \underline{X}' \rangle_N \quad (6)$$

and

$$\underline{P} = \langle \underline{X} \underline{X}' \rangle_S \quad (7)$$

The symbol $\langle \rangle$ represents the statistical average of the quantity within the brackets conditional on the hypothesis indicated by the subscript. The statistic U is compared to a threshold U_0 . For low signal-to-noise ratio, it is shown in Appendix A that the figure of merit of the optimum detection system is the quantity

$$d = \sqrt{\frac{1}{2} \text{tr} \left[(\underline{P} \underline{Q}^{-1})^2 \right]} \quad (8)$$

where $\text{tr}(\)$ denotes the trace of the matrix.

In order to consider the effect of the distance modulation, suppose for the moment that both the spectra of the signal $y(t)$ and of the noise background are flat ("white") over the frequency

band $0 \leq f \leq W$ and that they vanish for other frequencies. In practice it is found that both signal and noise spectra fall off at approximately the second power of frequency.⁽³⁾ However, it can be shown that the results are not materially affected by the exact spectral shapes as long as they are approximately the same for signal and noise, and as long as the modulation is very slow relative to $\frac{1}{2W}$, as would be the case here. If white noise is assumed, the individual samples are uncorrelated, and the covariance matrix \underline{Q} of the noise background is simply

$$\underline{Q} = N \underline{I} \quad (9)$$

where N is the average noise power (in units such as μbar^2) and \underline{I} is the n -dimensional unit matrix. Similarly, the covariance matrix of the sample vector \underline{Y} corresponding to the unmodulated stochastic signal $y(t)$ defined in Eq. (2) has the form

$$\langle \underline{Y} \underline{Y}^T \rangle_S = S \underline{I} \quad (10)$$

where S is the average signal power prior to modulation. As a result of the modulation, the covariance matrix \underline{P} has the form

$$\langle \underline{X} \underline{X}^T \rangle_S = \underline{P} = S \begin{bmatrix} f^2(t_1) & & & \bigcirc \\ & f^2(t_2) & & \\ & & \dots & \\ \bigcirc & & & f^2(t_n) \end{bmatrix} \quad (11)$$

Hence, the figure of merit d of Eq. (8) becomes

$$d = \frac{S}{N} \sqrt{\frac{1}{2} \sum_{i=1}^n f^4(t_i)} \quad (12)$$

which, by substitution of Eq. (3), becomes

$$d = \frac{k^2 S}{N} \sqrt{\frac{1}{2} \sum_{i=1}^n \left[\frac{1}{h^2 + (vt_i)^2} \right]^2} \quad (13)$$

The summation is most easily evaluated by converting it to an integral, which is permissible if $v^2(t_i - t_{i-1})^2/h^2 \ll 1$ as would normally be true here. Then

$$\sum_{i=1}^n \left[\frac{1}{h^2 + (vt_i)^2} \right]^2 \rightarrow \frac{1}{\Delta t} \int_{-T/2}^{T/2} \frac{dt}{\left[h^2 + (vt)^2 \right]^2} = 2W \int_{-T/2}^{T/2} \frac{dt}{\left[h^2 + (vt)^2 \right]^2}$$

where $\Delta t = t_i - t_{i-1} = \frac{1}{2W}$ by using the sampling theorem. The integration is straightforward and yields

$$d = \frac{k^2 S}{h^2 N} \sqrt{\frac{Wh}{v}} \sqrt{\frac{\frac{vT}{2h}}{\left[1 + \left(\frac{vT}{2h} \right)^2 \right]} + \tan^{-1} \frac{vT}{2h}} \quad (14)$$

It is clear that d is maximized by letting $T \rightarrow \infty$; in this case

$$d_{\max} = \frac{k^2}{h^2} \frac{S}{N} \sqrt{\frac{Wh}{v}} \sqrt{\frac{T}{2}} = 1.253 \frac{k^2}{h^2} \frac{S}{N} \sqrt{\frac{Wh}{v}} \quad (15)$$

However, if T is only $2h/v$, which means that the observation time is defined for the angle θ in Fig. 1 to vary from -45° to $+45^\circ$, then d has reached 98 per cent of its maximum value. Thus $T = 2h/v$ might be used as a practical definition of the time that the target is within sonar range.

The implementation of the physical device that forms the statistic U given by Eq. (5) follows directly by substituting Eqs. (9) and (11) into Eq. (5). This gives the result

$$U = \frac{S}{2N^2} \sum_{i=1}^n f^2(t_i) x_i^2$$

$$\rightarrow \frac{WS}{N^2} \int_{-T/2}^{T/2} f^2(t) [x(t)]^2 dt \quad (16)$$

where the conversion of the sum to the integral follows in the same way as in Eq. (13). This result implies that the detector consists of a square-law device followed by a cross correlator or filter matched to the modulation envelope as shown in Fig. 2. It is clear that the system cannot be constructed unless $f(t)$ is known, which means that h , v , and the time at which the target is closest to the buoy be known a priori, i.e., before the target appears. This is obviously an unreasonable requirement, and we consider, therefore, a simpler suboptimum scheme.

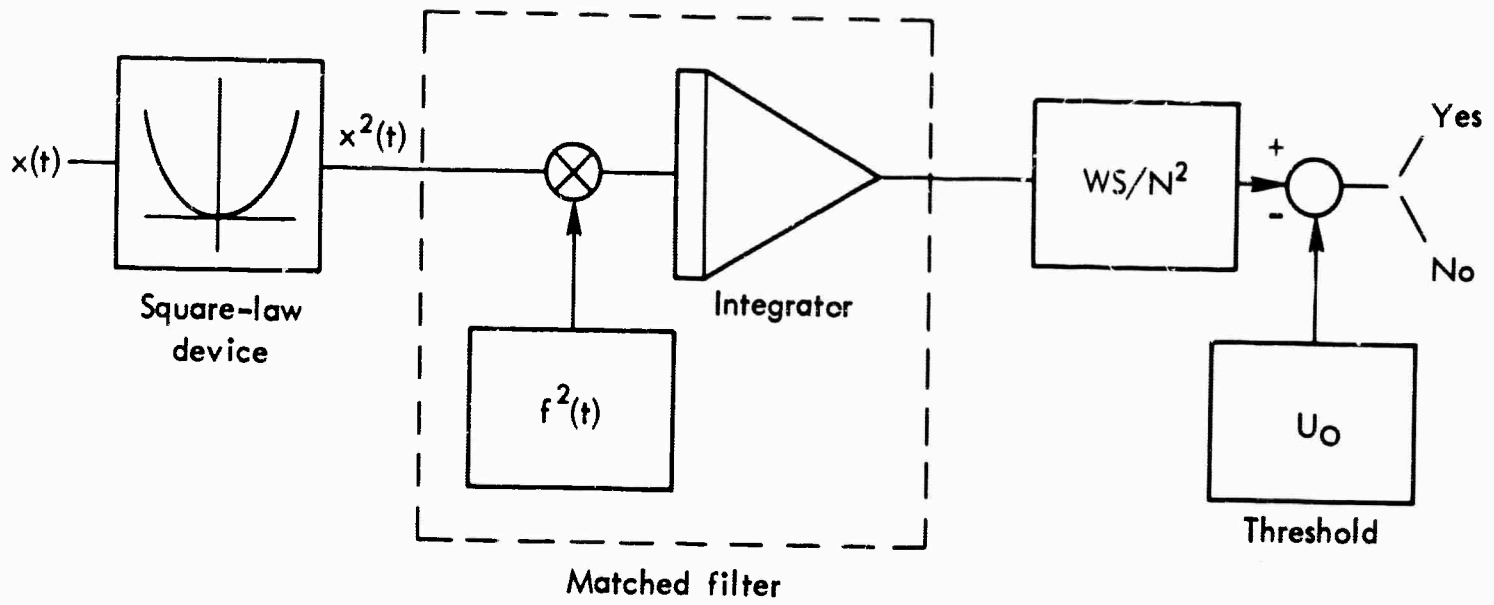

Fig.2—Likelihood ratio detector

III. SIMPLE SUBOPTIMUM DETECTOR FOR DETECTING A MOVING
TARGET IN NOISE WITH KNOWN STATISTICS

The suboptimum detector considered here consists simply of an integrator which integrates the squared received signal for T seconds, i.e., it puts out a test signal

$$U' = \frac{WS}{N^2} \int_{-T/2}^{T/2} [x(t)]^2 dt \quad (17)$$

An optimum value of T will be derived, and the relative magnitude of the detection index d' produced by this system will be obtained.

As shown in Appendix A, for small signal-to-noise ratio the detection index d can be written in the approximate form

$$d = \frac{\mu_1 - \mu_0}{\sigma_0} \quad (18)$$

where μ_1 and μ_0 are respectively the mean values of U under the hypothesis that signal is present and that it is absent, and σ_0 is the rms fluctuation of U for signal absent. For the suboptimum system we define the detection index in the same way with the μ 's and σ corresponding to U .

If signal is present, $X(t) = f(t) y(t) + n(t)$, and therefore from Eq. (17)

$$U' = \frac{WS}{N^2} \int_{-T/2}^{T/2} [f^2(t) y^2(t) + 2f(t) y(t) n(t) + n^2(t)] dt \quad (19)$$

The mean value μ_1' is obtained by averaging each term in the integrand separately. The cross-product term vanishes because $y(t)$ and $n(t)$ are independent. Then, using the fact that $y(t)$ and $n(t)$ are stationary and that the signal and noise powers are S and N respectively

$$\mu_1' = \left[\frac{WS^2}{N^2} \int_{-T/2}^{T/2} f^2(t) dt \right] + \left[W T \frac{S}{N} \right] \quad (20)$$

The integration of $f^2(t)$ given by Eq. (13) is straightforward and yields

$$\mu_1' = \frac{2k^2}{hv} \frac{WS^2}{N^2} \tan^{-1} \frac{vT}{2h} + W T \frac{S}{N} \quad (21)$$

If signal is absent, $f(t)$ in Eq. (19) is zero, and therefore the first term in Eq. (21) vanishes; hence

$$\mu_0' = W T \frac{S}{N} \quad (22)$$

Also, it is easily shown that for Gaussian noise and sample size $n = 2TW$

$$\left(\sigma_0' \right)^2 = W T \frac{S^2}{N^2} \quad (23)$$

Thus, the suboptimum detection index d' is

$$d' = \frac{\mu_1' - \mu_0'}{\sigma_0'} = \frac{k^2}{h^2} \frac{S}{N} \sqrt{TW} \frac{2h}{vT} \tan^{-1} \frac{vT}{2h} \quad (24)$$

This has been plotted in Fig. 3, together with the optimum detection index given in Eq. (14). Figure 3 shows that the optimum value of T is approximately $3 \frac{h}{v}$. With this value of T the suboptimum detection index reaches about 90 per cent of the absolute optimum given by Eq. (15). Figure 3 also shows that the index is not very sensitive to relatively large changes of T away from the optimum value; thus for T between $3/4 \frac{h}{v}$ and $15 \frac{h}{v}$ the index exceeds 60 per cent of the absolute optimum.

This result indicates that if the receiver simply integrates the squared received signal, the integration time should be optimized relative to the most distant target that the system can reasonably be expected to detect. Then for a target at a smaller range, T will be too large to be optimum; but since the target is closer, it will be more easily detectable so that the small loss in optimality of T is of no consequence.

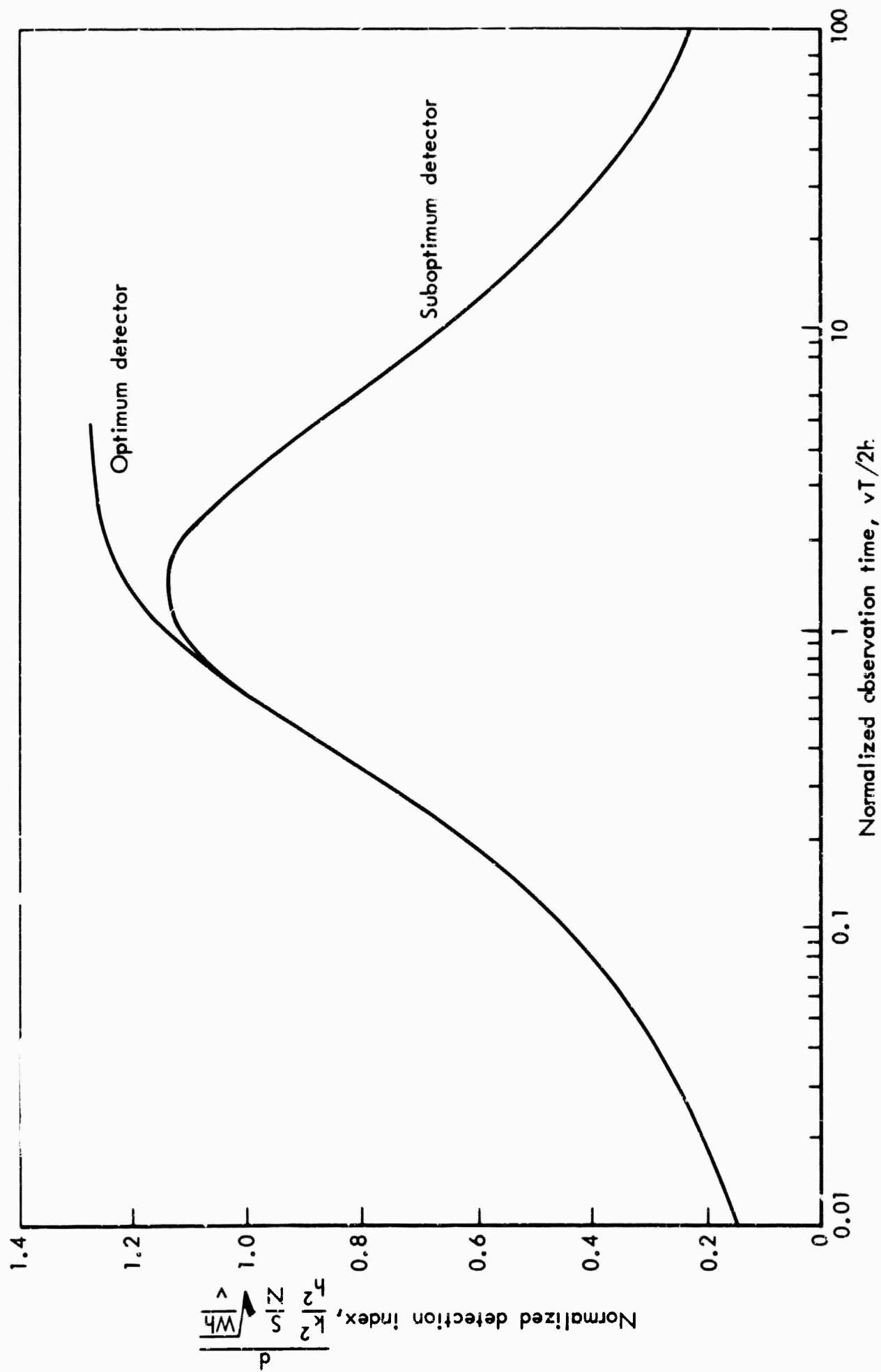

Fig. 3—Detection indices for optimum and suboptimum detectors

IV. EFFECT OF PRACTICAL SIGNAL AND NOISE SPECTRA

In Sections II and III the spectra of signals and noise were assumed to be white in order to simplify the analysis of the problem of motion of the target submarine past the sonobuoy. Since the analysis indicated that the effect of the distance modulation can be approximated quite well in the detector simply by integrating the received signal over an appropriate length of time, it seems reasonable to make the further approximation that the signal received from the target has constant power during the observation interval. This approximation makes it possible to treat both signal and noise as stationary processes, so that other than white spectra can be easily dealt with.

When it is desired to consider the detection of stationary signals with complicated spectral properties, it is most convenient to expand the received signal in a Fourier series⁽⁴⁾

$$x(t) = \sum_{k=1}^{\infty} (a_k \cos \omega_k t + b_k \sin \omega_k t)$$

where $\omega_1 = \Delta\omega = \frac{2\pi}{T}$ with T the observation interval. The a_k 's and b_k 's are Gaussian random variables with zero mean value; and for T very much larger than the inverse bandwidth of the received signal, they are approximately mutually independent, i.e., $a_k b_\ell = 0$ for all k and ℓ , and $\overline{a_k a_\ell} = \overline{b_k b_\ell} = 0$ for $k \neq \ell$. Their mean-square value is given by⁽⁴⁾

$$\begin{aligned} \overline{a_k^2} &= \overline{b_k^2} = G(f_k) \Delta f \\ &= \frac{1}{T} G(f_k) \end{aligned} \tag{26}$$

where $G(f)$ is the power spectral density of $x(t)$ and $f = \frac{\omega}{2\pi}$. If $x(t)$ consists of noise only

$$G(f) = N_0 N(f) \quad (27)$$

where N_0 is the low-frequency spectral level of the noise which is assumed to be finite. Thus

$$\lim_{f \rightarrow 0} N(f) = 1 \quad (28)$$

If $x(t)$ consists of signal and noise, then because of the independence of signal and noise

$$G(f) = S_0 S(f) + N_0 N(f) \quad (29)$$

where S_0 is the low-frequency spectral level at the receiver (again assumed finite) and $S(f)$ is the normalized spectral density of the signal with

$$\lim_{f \rightarrow 0} S(f) = 1 \quad (30)$$

The reasons for normalizing the spectral densities are discussed in Appendix B; they simplify the discussion of signal with unknown power level.

The standard theory of detection reviewed in Appendix A can be applied to the formulation in this section by considering the Fourier coefficients a_k and b_k as the elements of the sample vector \underline{X} , i.e., $\underline{X} = [a_1, b_1, a_2, b_2, \dots, a_n, b_n]$ where n is large enough so that all significant frequencies are included. Considering Eqs. (27) and (29), and because of the independence of the coefficients, the matrices \underline{P} and \underline{Q} become

$$\underline{P} = S_o \underline{P} = \frac{S_o}{T} \begin{bmatrix} S(f_1) & & & & \\ S(f_1) & & & & 0 \\ & S(f_2) & & & \\ & & S(f_2) & & \\ & & & \ddots & \\ & & & & S(f_n) \\ & 0 & & & \end{bmatrix} \quad (31)$$

$$\underline{Q} = N_o \underline{Q} = \frac{N_o}{T} \begin{bmatrix} N(f_1) & & & & \\ N(f_1) & & & & 0 \\ & N(f_2) & & & \\ & & N(f_2) & & \\ & & & \ddots & \\ & & & & N(f_n) \\ & 0 & & & \end{bmatrix} \quad (32)$$

Then the normalized test statistic considered in Appendix B (Eq. (B-3)) becomes

$$u = \frac{1}{2} \underline{x}' \underline{q}^{-1} \underline{p} \underline{q}^{-1} \underline{x} = \frac{T}{2} \sum_{k=1}^n (a_k^2 + b_k^2) \frac{S(f_k)}{[N(f_k)]^2} \quad (33)$$

It is easily seen that u is essentially the output of a system of the type shown in Fig. 4, where

$$|H(\omega)|^2 = \frac{S(\omega)}{[N(\omega)]^2} \quad (34)$$

is identical to an optimum filter discussed by Zadeh and Ragazzini.⁽⁵⁾

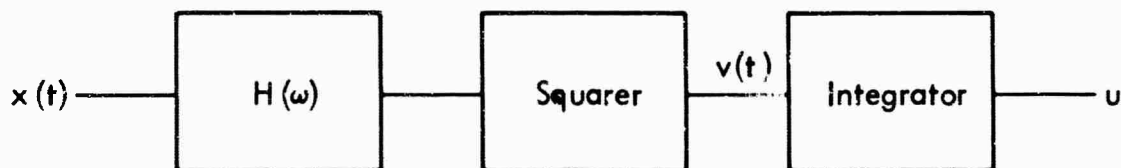

Fig. 4--Optimum detector

This can be shown by computing the output of the squarer which is given by

$$v(t) = \left[\sum a_k |H(\omega_k)| \cos(\omega_k t + \theta_k) + v_k |H(\omega_k)| \sin(\omega_k t + \theta_k) \right]^2$$

where θ_k is the phase angle of $H(\omega_k)$. Equation (33) then results since for large T the integrator output is Tv_{dc} where v_{dc} is the d_c component of $v(t)$. $H(\omega)$ must be stable and physically realizable, but this requirement causes no difficulty in practice.

Expressions for the false-alarm probability and the probability of true detection have been derived in Appendix B for the case of unknown but small signal power and are reproduced here for convenience

$$\alpha = \frac{1}{2} - \frac{1}{2} \Theta \left[\frac{u_0 - \frac{1}{2} N_0 \text{tr}(\underline{p}\underline{q}^{-1})}{N_0 \sqrt{\text{tr}[(\underline{p}\underline{q}^{-1})^2]}} \right] \quad (35)$$

$$1 - \beta = \frac{1}{2} - \frac{1}{2} \Theta \left[\frac{u_0 - \frac{1}{2} N_0 \text{tr}(\underline{p}\underline{q}^{-1})}{N_0 \sqrt{\text{tr}[(\underline{p}\underline{q}^{-1})^2]}} - \frac{1}{2} \frac{S_0}{N_0} \sqrt{\text{tr}[(\underline{p}\underline{q}^{-1})^2]} \right] \quad (36)$$

$$\text{where } \Theta(x) = \frac{2}{\sqrt{\pi}} \int_0^x e^{-t^2} dt$$

For the matrices \underline{p} and \underline{q} defined in Eqs. (31) and (32)

$$\text{tr}(\underline{p}\underline{q}^{-1}) = \sum_n \frac{S(\omega_n)}{N(\omega_n)} \rightarrow \frac{T}{2\pi} \int_0^\infty \frac{S(\omega)}{N(\omega)} d\omega \quad (37)$$

and

$$\text{tr}[(\underline{p}\underline{q}^{-1})^2] = \sum_n \left[\frac{S(\omega_n)}{N(\omega_n)} \right]^2 \rightarrow \frac{T}{2\pi} \int_0^\infty \left[\frac{S(\omega)}{N(\omega)} \right]^2 d\omega \quad (38)$$

where passage to the integral is, as usual, permissible if T is very large compared to the reciprocal of the bandwidth.

Example broadband spectra for submarine targets and background noise are shown in Fig. 5. The spectra obtained from actual measurements may differ considerably from these, and their exact shape depends on a number of factors in addition to target velocity and sea state.⁽⁶⁾ However, Eqs. (35) to (38) indicate that small differences in the shapes of signal and noise spectra have negligible effect on either the false-alarm or detection probability. The normalized spectra can therefore be approximated by

$$S(\omega) = \frac{\omega_1^2}{\omega^2 + \omega_1^2} \quad (39)$$

$$N(\omega) = \frac{\omega_0^2 (\omega^2 + \omega_2^2)}{\omega_2^2 (\omega^2 + \omega_0^2)} \quad (40)$$

Both signal and noise spectra fall off with the second power of frequencies above a frequency ω_1 or ω_2 respectively, and the noise spectrum levels off at a high frequency ω_2 because of the presence of locally generated white noise.

The integrals of Eqs. (37) and (38), after substitution of Eqs. (39) and (40), are in a standard form that is tabulated, for example, in Ref. 7. The result is

$$\frac{T}{2\pi} \int_0^{\infty} \frac{S(\omega)}{N(\omega)} d\omega = \frac{T}{4} \frac{\omega_1 \omega_2 (\omega_1 \omega_2 + \omega_0^2)}{\omega_0^2 (\omega_1 + \omega_2)} \quad (41)$$

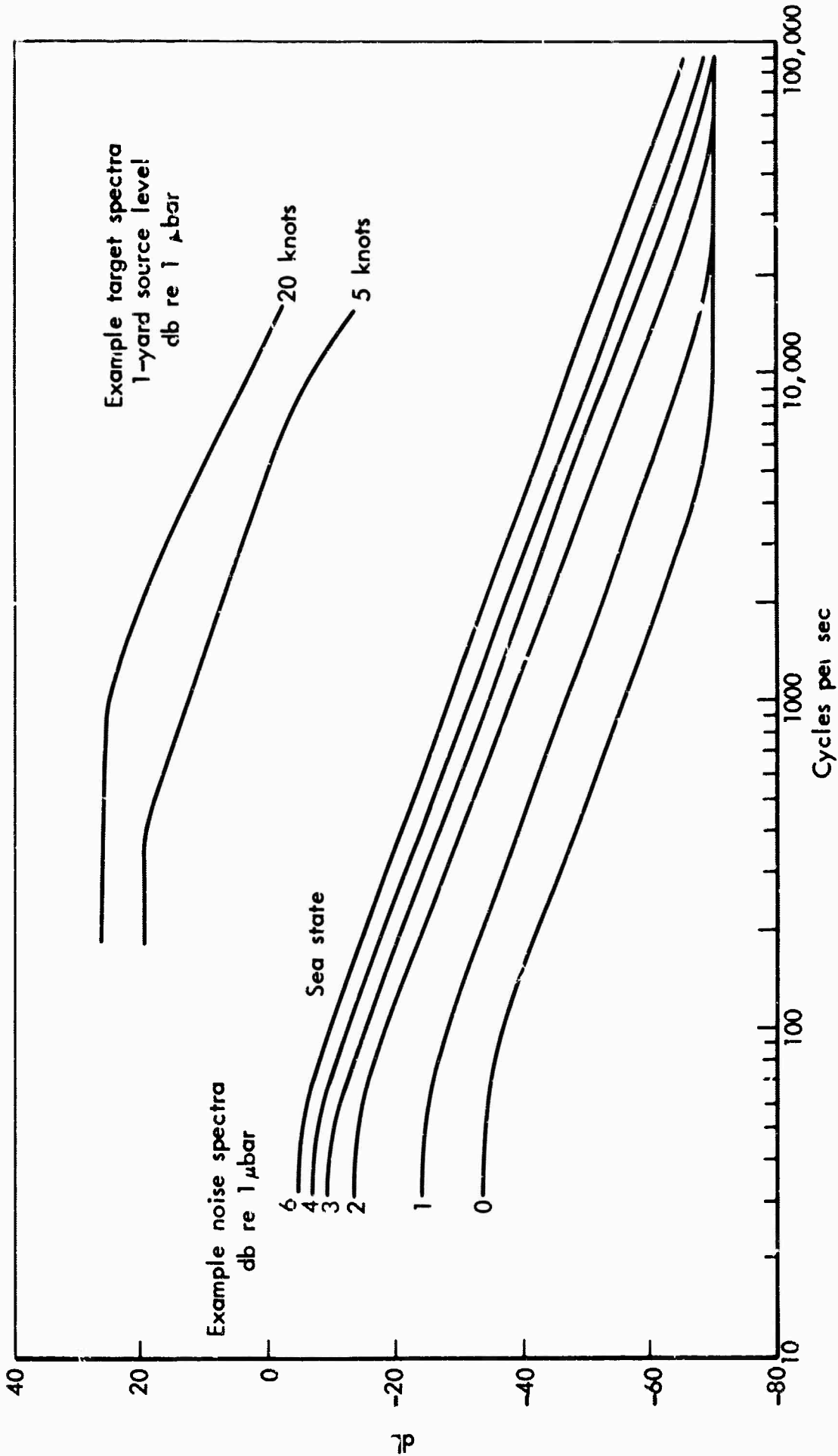

Fig. 5—Example spectral densities for target and for noise

and

$$\begin{aligned} \frac{T}{2\pi} \int_0^{\infty} \left[\frac{S(\omega)}{N(\omega)} \right]^2 d\omega &= \frac{T\omega_1 \omega_2}{4\omega_0^4 (\omega_1 + \omega_2)^4} [\omega_1^3 (\omega_2^4 + \omega_0^4) \\ &+ 4\omega_1^2 \omega_2 \omega_0^4 + 2\omega_1 \omega_2^2 \omega_0^2 (\omega_1^2 + 2\omega_0^2) \\ &+ \omega_2^3 (\omega_1^2 + \omega_0^2)^2] \end{aligned} \quad (42)$$

Typical values for ω_0 , ω_1 , and ω_2 are

$$\begin{aligned} \omega_0 &= 2\pi \times 50 \\ \omega_1 &= 2\pi \times 1000 \\ \omega_2 &= 2\pi \times 20,000 \end{aligned} \quad (43)$$

Hence $\omega_2 \gg \omega_1 > \omega_0$, and Eqs. (41) and (42) can be approximated by

$$\text{tr} (\underline{pq}^{-1}) = \frac{T}{2\pi} \int_0^{\infty} \frac{S(\omega)}{N(\omega)} d\omega \approx \frac{T\omega_2}{4} \left(\frac{\omega_1}{\omega_0} \right)^2 \quad (44)$$

$$\text{tr} (\underline{pq}^{-1})^2 = \frac{T}{2\pi} \int_0^{\infty} \left[\frac{S(\omega)}{N(\omega)} \right]^2 d\omega \approx \frac{T\omega_2}{4} \left(\frac{\omega_1}{\omega_0} \right)^4 \quad (45)$$

The false-alarm and detection probabilities can now be evaluated by substituting Eqs. (44) and (45) in Eqs. (35) and (36). It must be noted, however, that the low-frequency spectral level S_0 of the signal refers to the level at the receiving sonobuoy, whereas the level given in Fig. 5 is referenced to a distance of one yard from the target.

If the transmission loss is inversely proportional to the square of the distance, then by Eq. (3)

$$S_o = \frac{k^2 S_1}{h^2 + (vt)^2}$$

where S_1 is the low-frequency spectral level of the target relative to one yard and h is the minimum range in yards. The assumption that the target signal strength at the sonobuoy is constant during the observation time implies that $vt \ll h$ so that

$$S_o \approx S_1 \frac{k^2}{h^2} \quad (46)$$

Thus the false-alarm and detection probabilities become

$$\alpha = \frac{1}{2} - \frac{1}{2} \Theta(Z_\alpha) \quad (47)$$

$$1 - \beta = \frac{1}{2} - \frac{1}{2} \Theta(Z_\beta) \quad (48)$$

where

$$Z_\alpha = \frac{2 u_o}{N_o T w_2} \left(\frac{\omega_o}{\omega_1} \right)^2 - \frac{1}{4} \sqrt{T w_2} \quad (49)$$

$$Z_\beta = Z_\alpha - \frac{1}{4} \sqrt{T w_2} \left(\frac{S_1}{N_o} \right) \left(\frac{k^2}{h^2} \right) \left(\frac{\omega_1^2}{\omega_o^2} \right) \quad (50)$$

and where

$$\Theta(Z) = \frac{2}{\sqrt{\pi}} \int_0^Z e^{-t^2} dt$$

The magnitude of T in the above expression has been considered in Section II and was shown to depend on the range h . The detectable range might be defined as the value of h that makes $Z_p = 0$ subject to a particular false-alarm rate. For fixed false-alarm rate Z_α is a constant, k_α ; specifically for $\alpha = 10^{-5}$, $k_\alpha = 3.03$. Letting $T = 3h/v$ according to the results of Section II, we can solve Eq. (50) for h_{\max} , i.e.

$$0 = k_\alpha - \frac{1}{4} \sqrt{\frac{3h_{\max}^2 \omega_2}{v}} \left(\frac{S_1}{N_0} \right) \left(\frac{k^2}{h_{\max}^2} \right) \left(\frac{\omega_1^2}{\omega_0^2} \right)$$

or

$$\frac{h_{\max}}{k} = \left[\frac{1}{4k_\alpha} \sqrt{\frac{3\omega_2}{v}} \frac{S_1 \omega_1^2}{N_0 \omega_0^2} \right]^{2/3} \quad (51)$$

For $v = 20$ knots, we find from Fig. 5 that $S_1 = 27$ db. Also, assuming that the sea state is 1, $N_0 = -24$ db. ω_0 , ω_1 , and ω_2 are given in Eq. (43). Substituting all of these values into Eq. (51) with $k_\alpha = 3.03$ results in h_{\max} of about 600 mi, and T is on the order of 100 hr. These results are clearly unrealistic, and they indicate that an important factor has been omitted from the analysis.

V. EFFECT OF UNKNOWN NOISE LEVEL

The unreasonable result obtained in Section IV can be shown to result from the assumption that the noise level is known precisely. In order to see this, consider what actually happens in the detection system. The detector is shown in Fig. 4, and if noise only is present at the input, it is clear that u will be a somewhat random ramp function as shown in Fig. 6. If signal is also present, then the slope of the ramp is slightly greater, as shown. Thus, at any time T it is possible to establish a threshold which will usually reject

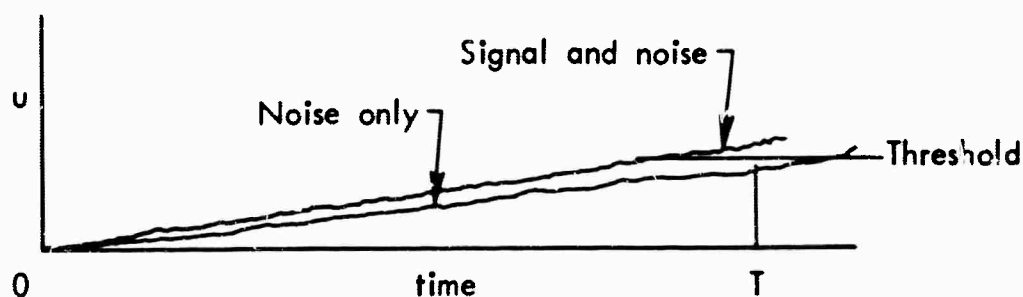

Fig. 6—Detector output versus time

the signal hypothesis when it is incorrect and accept it when it is correct (the word "usually" is used in a statistical sense). It can be seen from Fig. 6 that as long as the input power level with signal plus noise is even very slightly greater than it is with noise alone, the average slopes of the two ramps are different and they continue to separate as the observation time is increased.

This discussion is valid if one can assume that the noise power is exactly known. Suppose, however, that there is some uncertainty about the noise power level. Then, in order to achieve a specified

false-alarm probability, the threshold would have to be set at a high enough level so that the maximum expected noise level would yield the specified false-alarm rate. If then the noise level is actually less than the maximum value, u would usually be below the threshold for both signal present and absent unless the signal power exceeds the uncertainty in the noise power.

In view of this discussion, one can, for a given observation time T , define a minimax range h_m as the range that causes Z_β to vanish, with N_o taking on its smallest value, for a Z_α taking on the value corresponding to the specified false-alarm probability with the largest value of N_o .

Quantitatively, suppose that the noise level is somewhere between $N_o + \Delta N_o$ and $N_o - \Delta N_o$. Then if the value of Z_α of Eq. (49) is fixed at K_α

$$K_\alpha = \frac{2u_o}{(N_o + \Delta N_o)\sqrt{T\omega_2}} \left(\frac{\omega_o^2}{\omega_1} \right) - \frac{1}{4} \sqrt{T\omega_2} \quad (52)$$

The value of Z_α to be used in Eq. (50) is then

$$\begin{aligned} Z_\alpha &= (K_\alpha + \frac{1}{4} \sqrt{T\omega_2}) \left(\frac{N_o + \Delta N_o}{N_o - \Delta N_o} \right) - \frac{1}{4} \sqrt{T\omega_2} \\ &= K_\alpha \left(\frac{N_o + \Delta N_o}{N_o - \Delta N_o} \right) + \frac{\sqrt{T\omega_2}}{4} \left(\frac{2 \Delta N_o}{N_o - \Delta N_o} \right) \end{aligned} \quad (53)$$

and h_m is obtained from

$$K_{\alpha} \left(\frac{N_o + \Delta N_o}{N_o - \Delta N_o} \right) + \frac{1}{4} \sqrt{\frac{3h_m \omega_2}{kv}} \left(\frac{2 \Delta N_o}{N_o - \Delta N_o} \right) - \frac{1}{4} \sqrt{\frac{3h_m \omega_2}{kv}} \frac{k^2 \omega_1^2 S_1}{h_m^2 \omega_o^2 (N_o - \Delta N_o)} = 0 \quad (54)$$

A set of curves of h_m versus $\Delta N_o/N_o$ is given in Fig. 7 for various sea states, and for a target velocity of 20 knots. The example spectra of Fig. 5 have been used in this computation. Values of ω_o , ω_1 , and ω_2 are those given in Eq. (43). For these values, and for $\Delta N_o/N_o > .01$, the first term in Eq. (54) is negligible, and a very good approximate solution for h_m is

$$\frac{h_m}{k} = \frac{\omega_1}{\omega_o} \sqrt{\frac{S_1}{2\Delta N_o}} \quad (55)$$

The optimum time of observation is given by $T = \frac{3h_m}{v}$, which for a 20-knot target velocity is $T = .15 h_m$ hr if h_m is expressed in n mi. Thus the optimum time can be read from Fig. 7. According to Eq. (55) different target velocities affect the range only through the signal spectral level S_1 . According to Fig. 5, S_1 for a 5-knot target is about 10 db below the value for a 20-knot target. Hence, h_m is .316 as large for a 5-knot target as for the 20-knot target, and the optimum value of T becomes $.6h_m$ hours.

By setting $N_o + \Delta N_o = N_{\max}$ and $N_o - \Delta N_o = N_{\min}$, Eq. (55) can be put into the form

$$\frac{h_m}{k} = \frac{\omega_1}{\omega_o} \sqrt{\frac{S_1}{N_{\min}}} \sqrt{\frac{1}{\frac{N_{\max}}{N_{\min}} - 1}}$$

Although this expression is equivalent to Eq. (55), it is more convenient when N_{\max}/N_{\min} is large. It has been used for the curves shown in Fig. 8, which are also based on the example spectra of Fig. 5 and on the values of ω_0 , ω_1 , and ω_2 from Eq. (43).

It should be noted that if the approximate expression Eq. (55) holds, then k_m is independent of T since T enters Eq. (54) through the square-root factors that have been cancelled out. Thus, although it is desirable that the adjustment of T be approximately correct in order to optimize the detection index as discussed in Section III, the fact that different target velocities require different values of T would not have to be considered in the design of the detection system. T could be determined by measurements of the sea state (or noise background) if the expected uncertainty in the noise measurement is known.

In practice, it appears that accuracies of ± 1 db are about the best that can be expected.* These accuracies correspond to $\Delta N_0/N_0 = .1$, and therefore, according to Fig. 7, for sea state 0 the minimax detection range for a 20-knot submarine is about 25 mi, with more normal sea states yielding ranges of about 8 mi or less.

The probability of detection as a function of range depends on the probability distribution of the actual noise level within its permissible range. The only case considered in this section is that this distribution is uniform, i.e., if the actual noise level is N_1

* Private communication with J. Kingsbury, Navy Underwater Sound Laboratories, New London, Connecticut.

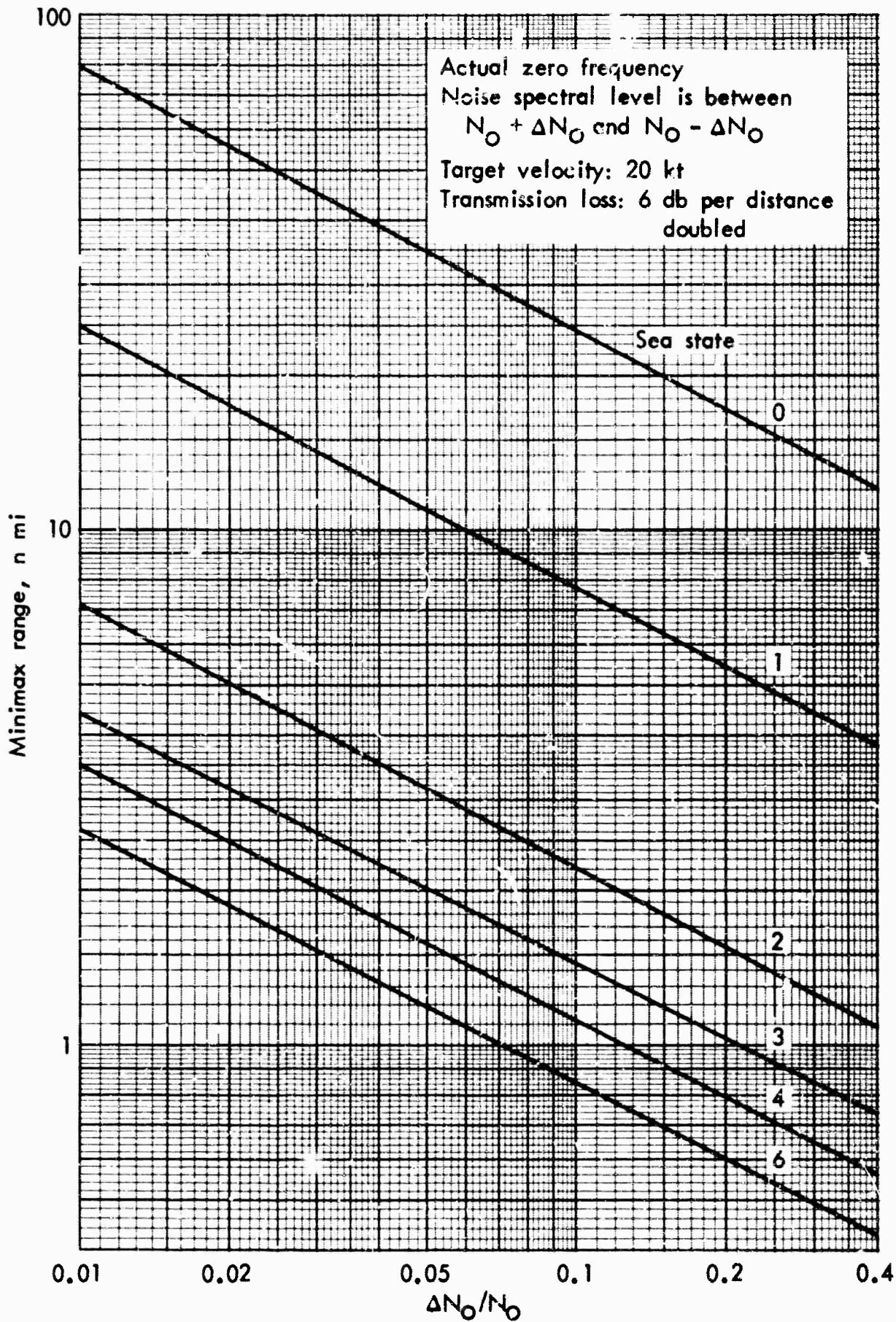

Fig. 7—Minimax range versus uncertainty in noise level

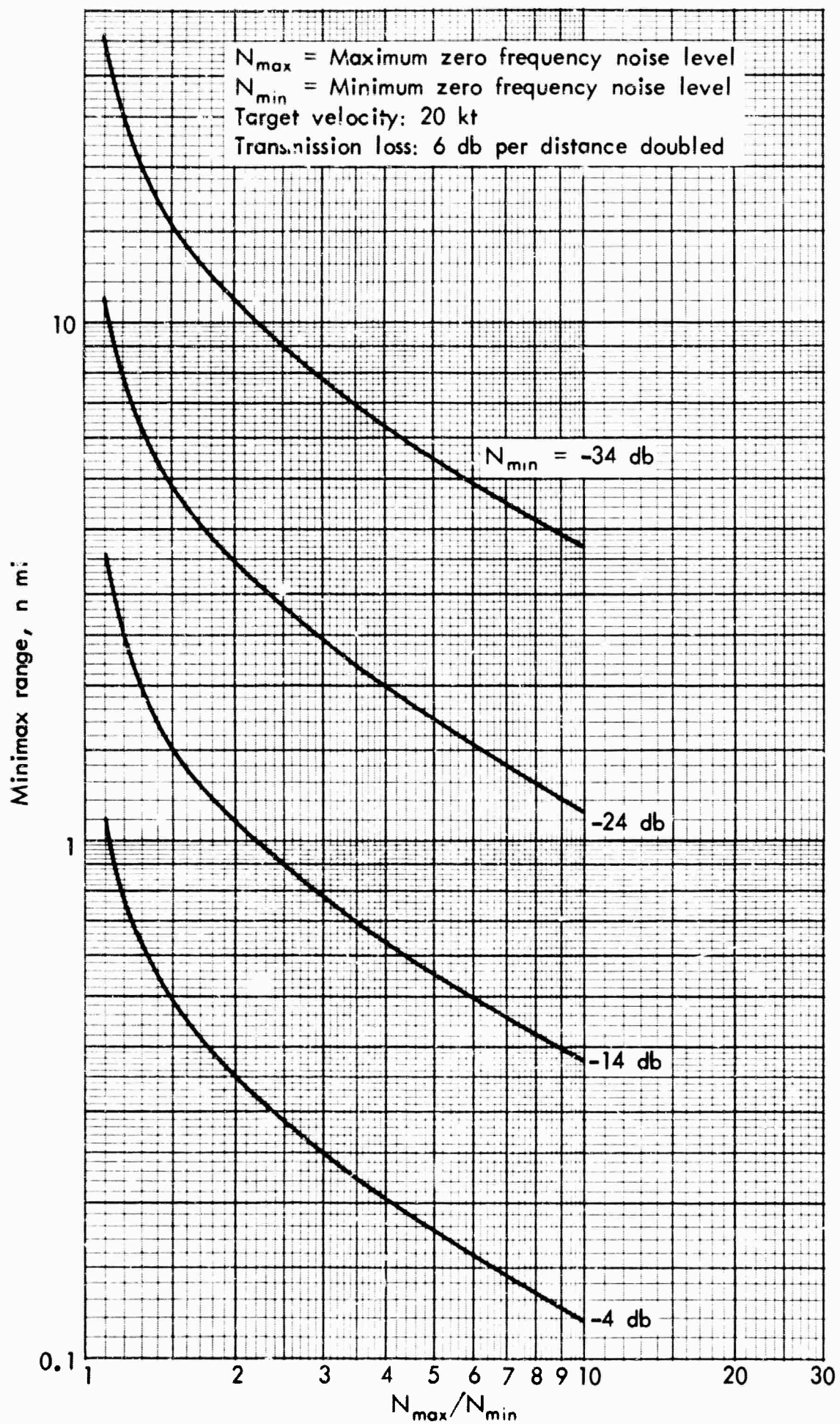

Fig.8—Minimax range versus noise uncertainty

$$p(N_1)dN_1 = \frac{dN_1}{2\Delta N_0}, \quad N_0 - \Delta N_0 < N_1 < N_0 + \Delta N_0 \quad (56)$$

$$p(N_1) = 0 \quad \text{otherwise}$$

The computation for the detection probability is simplified by the fact that for a given value of N_1 , $(1-\beta)$ decreases very rapidly for small changes in h near the nominal value. If T is one hour and ω_2 is $2\pi \times 20,000$ rad/sec, $T\omega_2 = 4.5 \times 10^8$ rad. For this value of $T\omega_2$ it can be shown by direct computation of $(1-\beta)$ according to Eq. (48) that if $(1-\beta) = \frac{1}{2}$ for $h = h_0$, $(1-\beta) \approx 1$ for $h = .999 h_0$ and $(1-\beta) \approx 0$ for $h = 1.001 h_0$. Hence, if we use the notation $p(D/N_1)$ instead of $(1-\beta)$ to indicate that the detection probability is conditional on N_1 , we have approximately

$$p(D/N_1) = 1 - u[h - h(N_1)] \quad (57)$$

where $u[]$ is the unit step function and where, by an argument similar to that leading to Eq. (55)

$$\frac{h(N_1)}{k} = \frac{\omega_1}{\omega_0} \frac{\sqrt{S_1}}{\sqrt{N_0 + \Delta N_0 - N_1}} \quad (58)$$

The joint probability $p(D, N_1)$ obtained by multiplying Eqs. (56) and (57) may now be integrated over N_1 to obtain the desired marginal probability density $P(D)$. The integration is straightforward and yields

$$P(D) = 1 \quad \text{for } \frac{h}{k} \leq \frac{\omega_1}{\omega_0} \sqrt{\frac{S_1}{2\Delta N_0}} \quad (59)$$

$$P(D) = \frac{\omega_1^2 S_1 k^2}{2\omega_0^2 h^2 \Delta N_0} \quad \text{for } \frac{h}{k} \geq \frac{\omega_1}{\omega_0} \sqrt{\frac{S_1}{2\Delta N_0}}$$

This expression is plotted in Fig. 9. It is seen that the probability of detection is unity for ranges less than the minimax value and that it drops off rather rapidly for larger ranges.

The detection range h_d is commonly defined as the value of the range for which the detection probability $p(D) = \frac{1}{2}$. It is clear from Eq. (59) that this is given by

$$h_d = \sqrt{2} h_m = k \frac{\omega_1}{\omega_0} \sqrt{\frac{S_1}{\Delta N_0}} \quad (60)$$

This range can easily be read from Figs. 7 and 8 by a change in the ordinate scale.

It might be noted that a change in the false-alarm rate has essentially no effect whatever on the minimax or detection ranges, or on the detection probability. A change in the false-alarm rate results in a change in K_α , but the term in Eq. (54) containing K_α was neglected in obtaining Eq. (55), and in all subsequent equations. Hence, the results of Figs. 7, 8, and 9 do not depend on the false-alarm probability.

The results of this section are easily extended to transmission-loss curves other than the simple 6 db per distance doubled curve considered thus far. Suppose that Eq. (46) is replaced by the more general equation

$$S_0 = S_1 g\left(\frac{h}{k}\right) \quad (61)$$

Then, if in Eq. (54) the term involving K_α is again ignored, Eq. (55) becomes

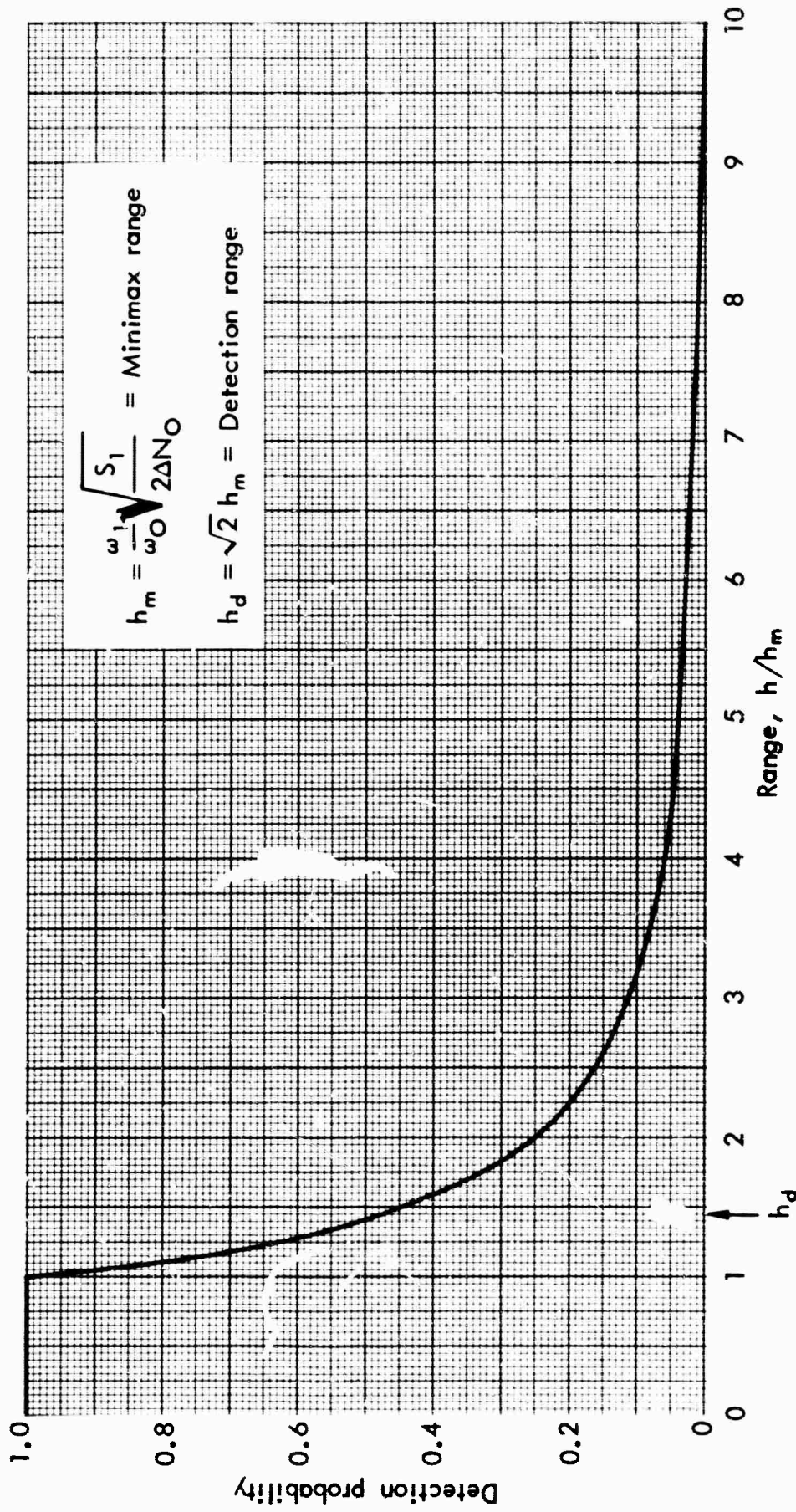

Fig. 9—Detection probability versus range

$$h_m = kg^{-1} \left[\frac{2\Delta N_o}{S_1} \left(\frac{\omega_o}{\omega_1} \right)^2 \right] \quad (62)$$

Also, Eq. (59) becomes

$$P(D) = 1 \quad \text{for } g\left(\frac{h}{k}\right) \geq 2 \frac{\Delta N_o}{S_1} \left(\frac{\omega_o}{\omega_1} \right)^2 \quad (63)$$

$$P(D) = \frac{S_1}{2\Delta N_o} \left(\frac{\omega_1}{\omega_o} \right)^2 g\left(\frac{h}{k}\right) \quad \text{for } g\left(\frac{h}{k}\right) \leq 2 \frac{\Delta N_o}{S_1} \left(\frac{\omega_o}{\omega_1} \right)^2$$

Under certain conditions the transmission-loss curve appears to have approximately an 8 db per distance doubled slope. Then $g(h/k) = (h/k)^{-2.65}$. The minimax range corresponding to this form of $g(h/k)$ is plotted in Figs. 10 and 11. The larger transmission loss results in a considerable reduction in range, as might be expected. As before, the detection range can be defined by $h_d = \sqrt{2 h_m}$.

As a result of multiple reflections, $g(h/k)$ frequently has a more complicated form, of the type shown in Fig. 12, where the peak after the first dip typically occurs at 10 to 20 n mi. It is clear from Eq. (63) that under these conditions the form of the detection probability curve will be as shown in Fig. 12 and that there may be several widely different values of h_m and h_d .

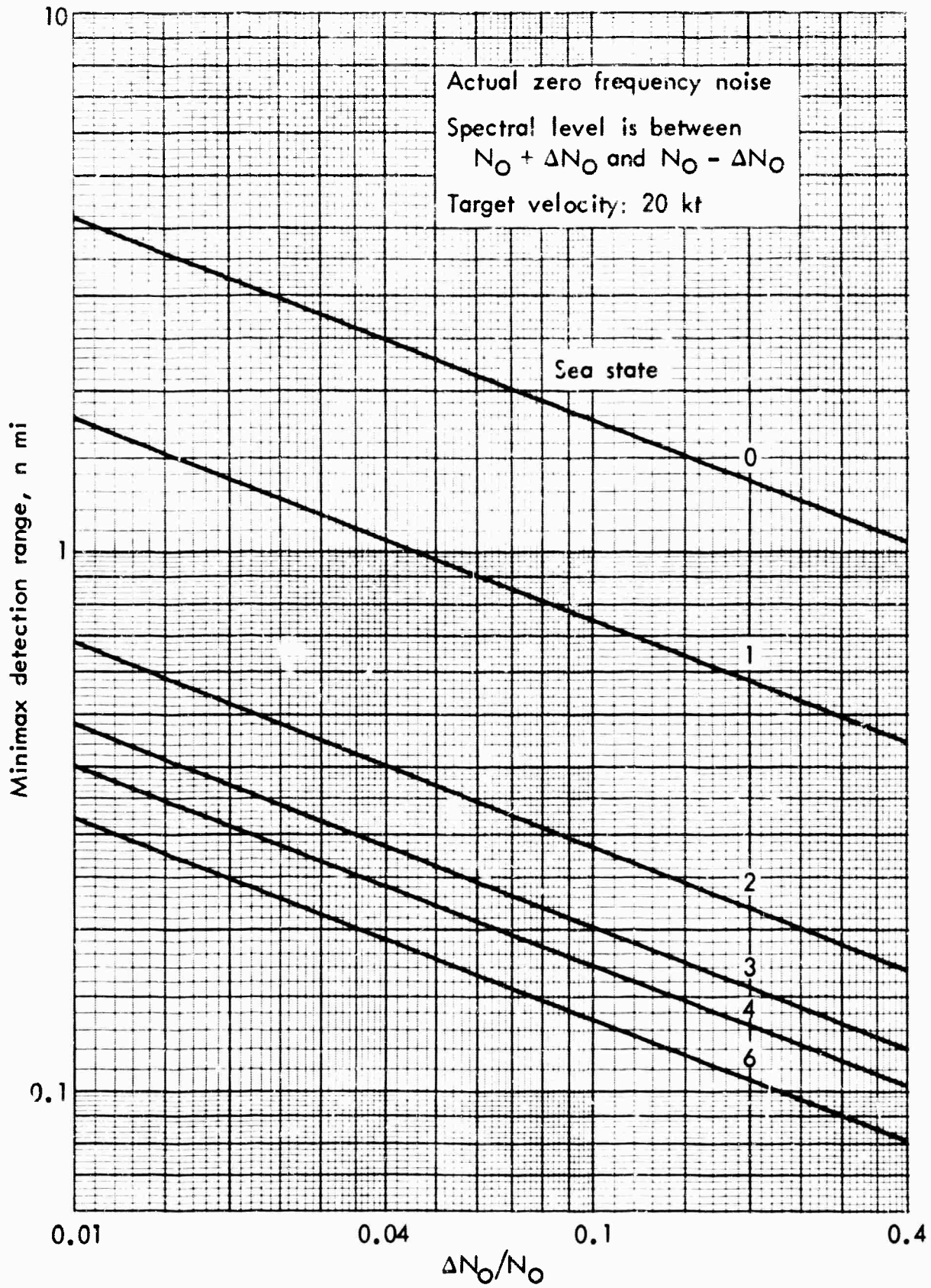

Fig. 10—Minimax range versus uncertainty in noise level for 8 db per distance doubled transmission loss

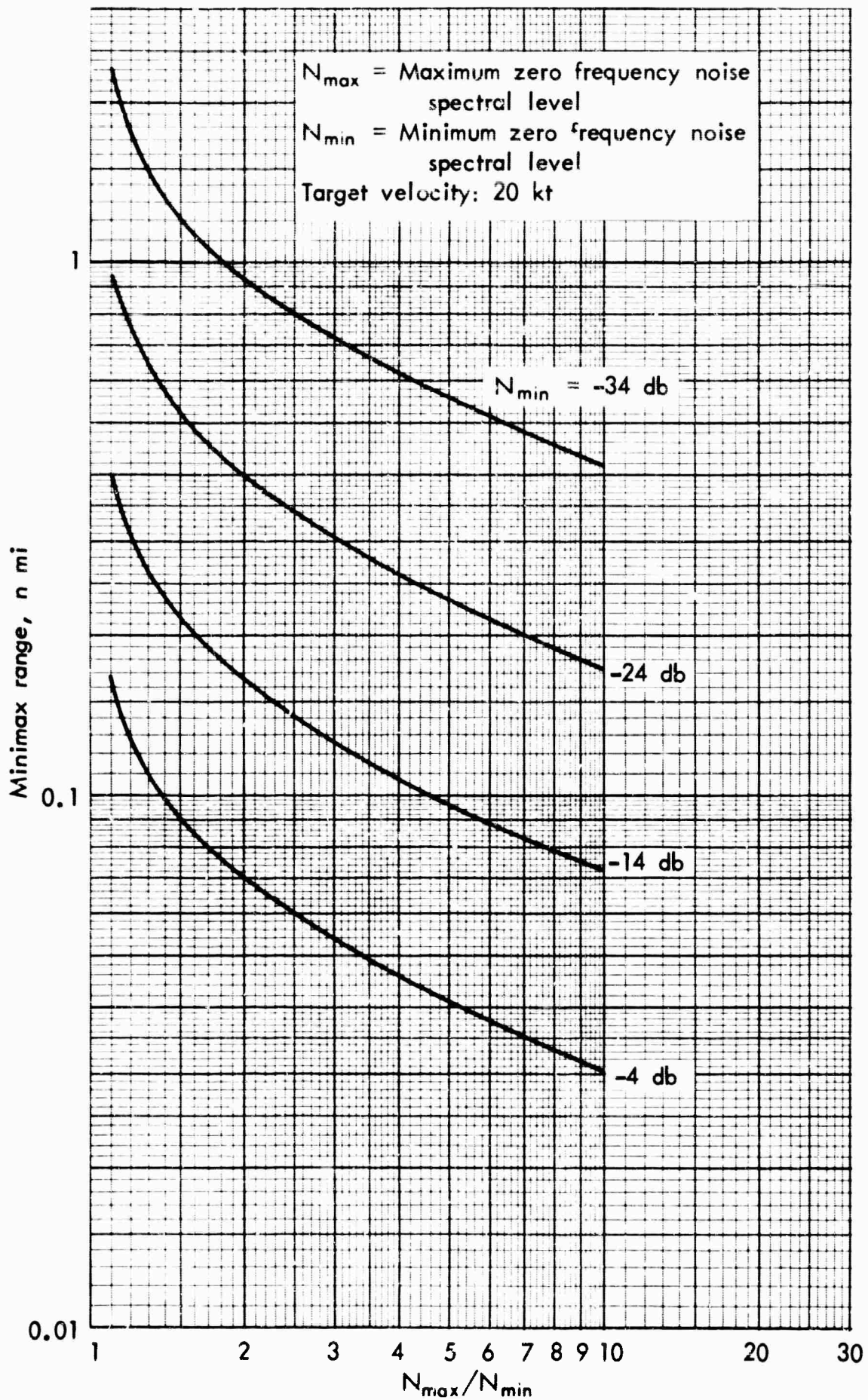

Fig. 11—Minimax range versus noise uncertainty for 8 db per distance doubled transmission loss

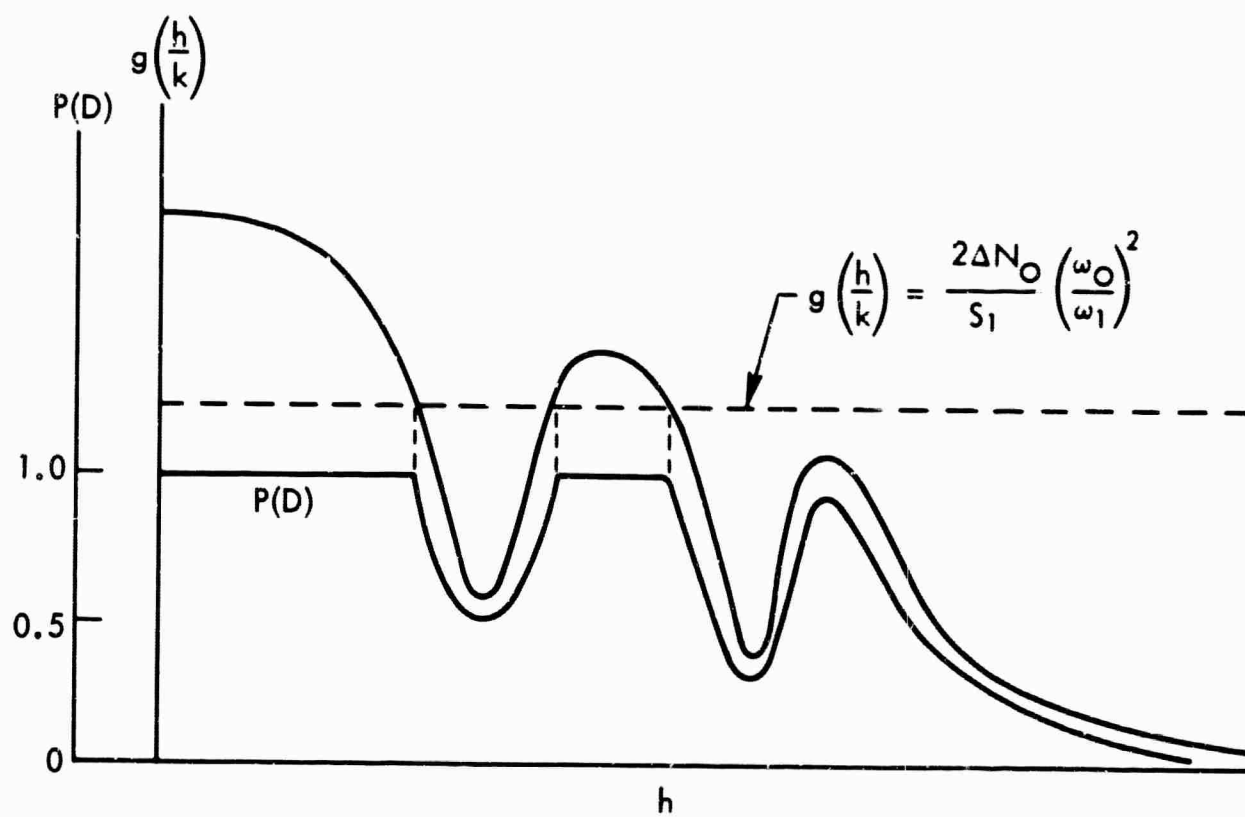

Fig. 12—Transmission-loss function and resulting detection probability

VI. UNCERTAINTY OF NOISE LEVEL DESCRIBABLE BY A GAUSSIAN
PROBABILITY DENSITY FUNCTION

In Section V, it was assumed that definite upper and lower bounds could be placed on the possible value of the noise level, and in the computation for the detection probability, it was assumed that all noise levels inside these limits were equally likely. Although it is conceivable that certain techniques for determining the noise level might result in noise uncertainties of this type, it seems more likely in general that the noise-level uncertainty would be more accurately described by a probability density function such as the Gaussian density function, for which it is impossible to define upper and lower bounds on the noise level. Therefore, the concept of a minimax range as defined in Section V is not applicable. However, if the probability density function of the noise level is known, it is still possible to determine a threshold resulting in a specified average false-alarm rate.

If the probability density function of the noise level is $p(N_1)$, then the average false-alarm and detection probabilities are, respectively

$$\bar{\alpha} = \int_{-\infty}^{\infty} \alpha(N_1) p(N_1) dN_1 \quad (64)$$

$$(1-\bar{\beta}) = 1 - \int_{-\infty}^{\infty} \beta(N_1) p(N_1) dN_1 \quad (65)$$

where $\alpha(N_1)$ and $\beta(N_1)$ are the conditional false-alarm and miss probabilities under the assumption that the noise level is N_1 , i.e., they are given by Eqs. (47) and (48) with N_0 replaced by N_1 .

For the large values of $T\omega_2$ that are typical in this application, $\alpha(N_1)$ and $\beta(N_1)$ can again be approximated very closely by unit step functions, specifically

$$\alpha(N_1) = u(N_1 - N_{10}) \quad (66)$$

where N_{10} is the noise level for which $Z_\alpha = 0$. Thus, from Eq. (49), with N_0 replaced by N_{10} and $Z_\alpha = 0$

$$N_{10} = \frac{8u_0}{T\omega_2} \left(\frac{\omega_0}{\omega_1} \right)^2 \quad (67)$$

so that

$$\alpha(N_1) = u \left[N_1 - \frac{8u_0}{T\omega_2} \left(\frac{\omega_0}{\omega_1} \right)^2 \right] \quad (68)$$

Substitution of Eq. (68) into Eq. (64) results in

$$\bar{\alpha} = \int_{N_{10}}^{\infty} p(N_1) dN_1 \quad (69)$$

One way of estimating the noise level is to make a long-time measurement of the received signal power and to use the average power as the estimate of noise power. This is a workable procedure because if a signal is present for a relatively short time compared to the time taken for the noise measurement, then the short-time rise in power due to the signal has a negligible effect on the long-time average. If the noise level is estimated in this way, then by the

central limit theorem the probability density $p(N_1)$ does, in fact, approach the Gaussian, i.e.

$$p(N_1) = \frac{1}{\sqrt{2\pi} \sigma_N} e^{-\frac{1}{2} \left(\frac{N_1 - N_0}{\sigma_N} \right)^2} \quad (70)$$

where N_0 is the mean value of N_1 , and σ_N^2 is the variance of the measurement.* Then

$$\bar{\alpha} = \frac{1}{2} - \frac{1}{2} \Theta \left(Z_{\bar{\alpha}} \right) \quad (71)$$

where

$$Z_{\bar{\alpha}} = \frac{\frac{8u_0}{T\omega_2} \frac{\omega_0^2}{\omega_1} - N_0}{\sqrt{2} \sigma_N} \quad (72)$$

As before, if $\bar{\alpha}$ is specified, $Z_{\bar{\alpha}} = K_{\bar{\alpha}}$, a constant. Hence, the threshold u_0 is given by

$$u_0 = T\omega_2 \left(\frac{N_0 + K_{\bar{\alpha}} \sqrt{2} \sigma_N}{8} \right) \left(\frac{\omega_1}{\omega_0} \right)^2 \quad (73)$$

The conditional miss probability $\beta(N_1)$ is similarly approximated by a unit step function.

$$\beta(N_1) = u(N_1 - N_{11}) \quad (74)$$

where N_{11} is the value of noise level for which $Z_{\beta} = 0$. This can be obtained by replacing N_0 by N_{11} in Eqs. (49) and (50), and setting $Z_{\beta} = 0$. The value of u_0 to be used in Eq. (49) is that of Eq. (73) (with N_0 left unchanged, since u_0 is a fixed threshold). The result is

*Note that σ_N^2 generally decreases with observation time, the decrease is, however, limited by the degree to which the sea noise is non-stationary.

$$N_{11} = N_o + K_{\bar{\alpha}} \sqrt{2} \sigma_N - \frac{S_1 k^2}{h^2} \left(\frac{\omega_1}{\omega_o} \right)^2 \quad (75)$$

Then, if $p(N_1)$ as given by Eq. (70) is substituted in Eq. (65), the average detection probability is found to be

$$p(\bar{D}) = (1 - \bar{\beta}) = \frac{1}{2} - \frac{1}{2} \Theta \left[K_{\bar{\alpha}} - \frac{1}{\sqrt{2} \sigma_N} \frac{S_1 k^2}{h^2} \left(\frac{\omega_1}{\omega_o} \right)^2 \right] \quad (76)$$

The detection range $h_{\bar{D}}$ can be defined here as the value of h for which $p(\bar{D}) = \frac{1}{2}$; this gives

$$h_{\bar{D}} = k \frac{\omega_1}{\omega_o} \sqrt{\frac{S_1}{\sqrt{2} \sigma_N K_{\bar{\alpha}}}} \quad (77)$$

A curve of detection range versus σ_N for the example 20-knot target used in Section V is given in Fig. 13; the detection probability is shown in Fig. 14. Note that in the present case both $h_{\bar{D}}$ and $p(\bar{D})$ are functions of $K_{\bar{\alpha}}$. However, since even for rather large changes in false-alarm rate $K_{\bar{\alpha}}$ only changes a small amount, the effect of change of false-alarm rate, although no longer completely negligible as in Section V, still has only a very small effect on $h_{\bar{D}}$ or $p(\bar{D})$. This is clearly shown in Figs. 13 and 14.

In comparing the detection range $h_{\bar{D}}$ of this section with h_d of the last section, one must note that $2\Delta N_o$ of Section V is the maximum uncertainty range, while σ_N of this section is the standard

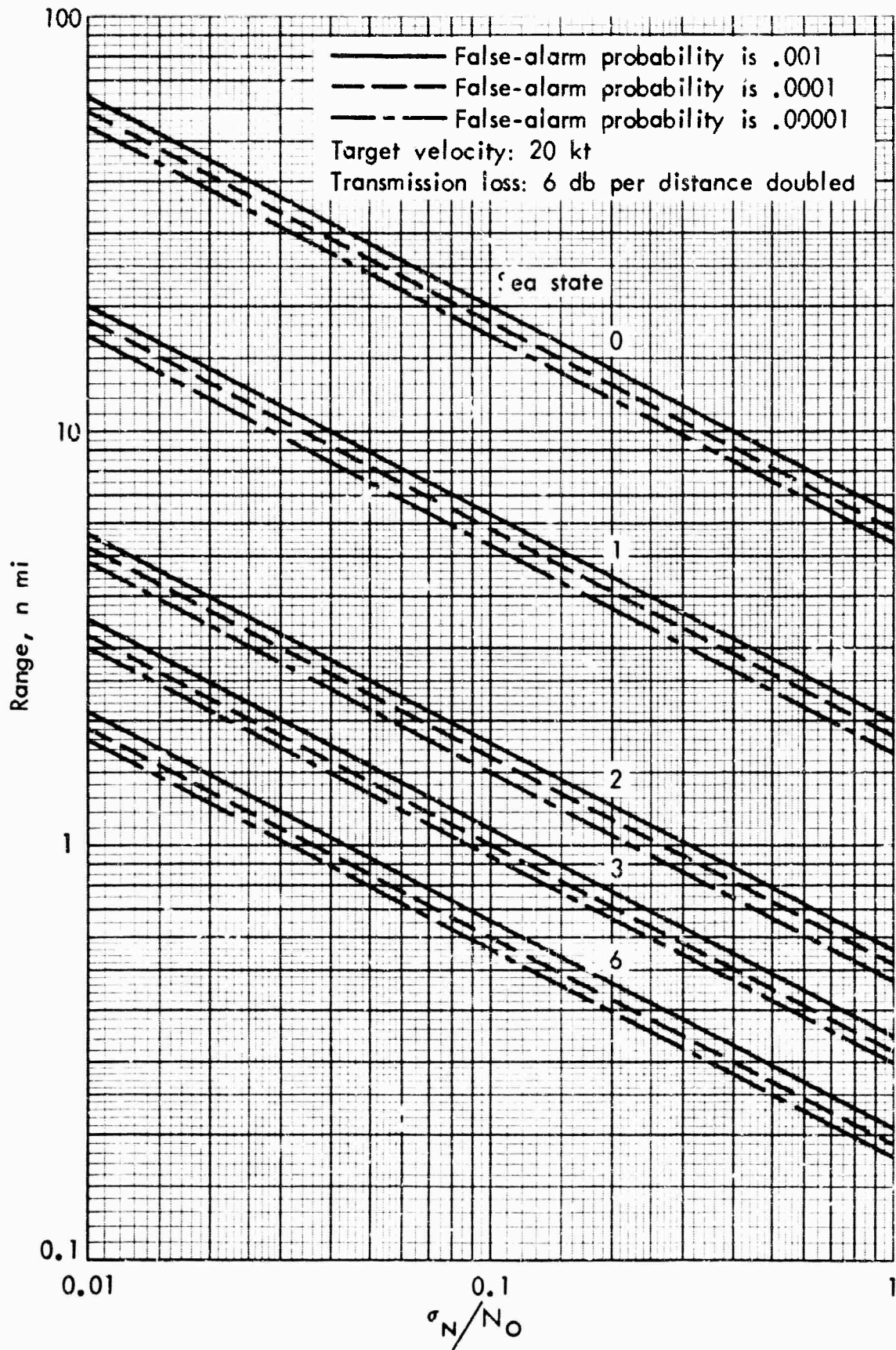

Fig. 13 — Detection range versus σ_N

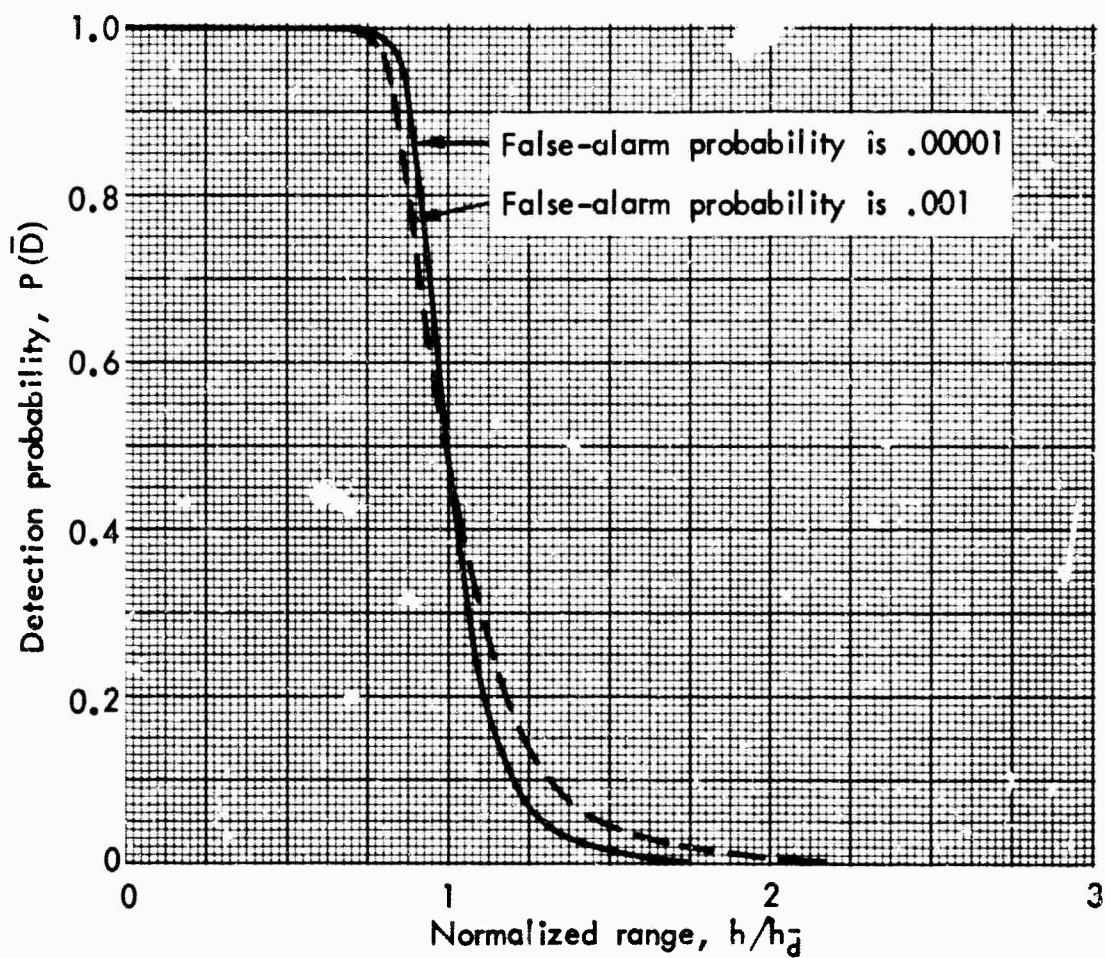

Fig.14 -Average detection probability versus range

deviation of the noise uncertainty. For a rectangular distribution, the standard deviation would be

$$\sigma_N = \frac{\Delta N_0}{\sqrt{3}} \quad (78)$$

If this is used in Eq. (77), the comparison with the detection range of Section V (Eq. (60)) gives

$$\frac{h_d}{h_d^-} = \sqrt{K_{\bar{\alpha}} \sqrt{\frac{2}{3}}} \quad (79)$$

Thus, for $K_{\bar{\alpha}} = 3.03$ ($\bar{\alpha} = 10^{-5}$), $h_d/h_d^- = 1.57$.

The detection probability drops off much more rapidly for ranges in excess of the detection range h_d^- here than in the last section. This is, of course, due to the fact that if the noise-level uncertainty has a Gaussian distribution, it is much less likely that the actual noise level differs from the mean value than if the uncertainty has a uniform distribution, assuming that the variances are comparable.

The effect of transmission-loss curves other than the 6 db per distance doubled curve considered here is essentially the same as in Section V. The argument of Θ in the equation for $P(\bar{D})$ (Eq. (76)) would be proportional to $g(h/k)$ rather than h^{-2} . However, because of the nonlinear distortion of the argument by the error function, a $g(h/k)$ such as that shown in Fig. 12 would result in a much more violent fluctuation of $P(\bar{D})$; in fact, it can be concluded from Fig. 14 that one would have approximately

$$P(\bar{D}) \approx 1 \quad g\left(\frac{h}{k}\right) > \frac{\sqrt{2} \sigma_N K_a}{S_1} \left(\frac{\omega_0}{\omega_1}\right)^2$$

$$P(\bar{D}) \approx 0 \quad g\left(\frac{h}{k}\right) < \frac{\sqrt{2} \sigma_N K_a}{S_1} \left(\frac{\omega_0}{\omega_1}\right)^2$$

This is illustrated in Fig. 15.

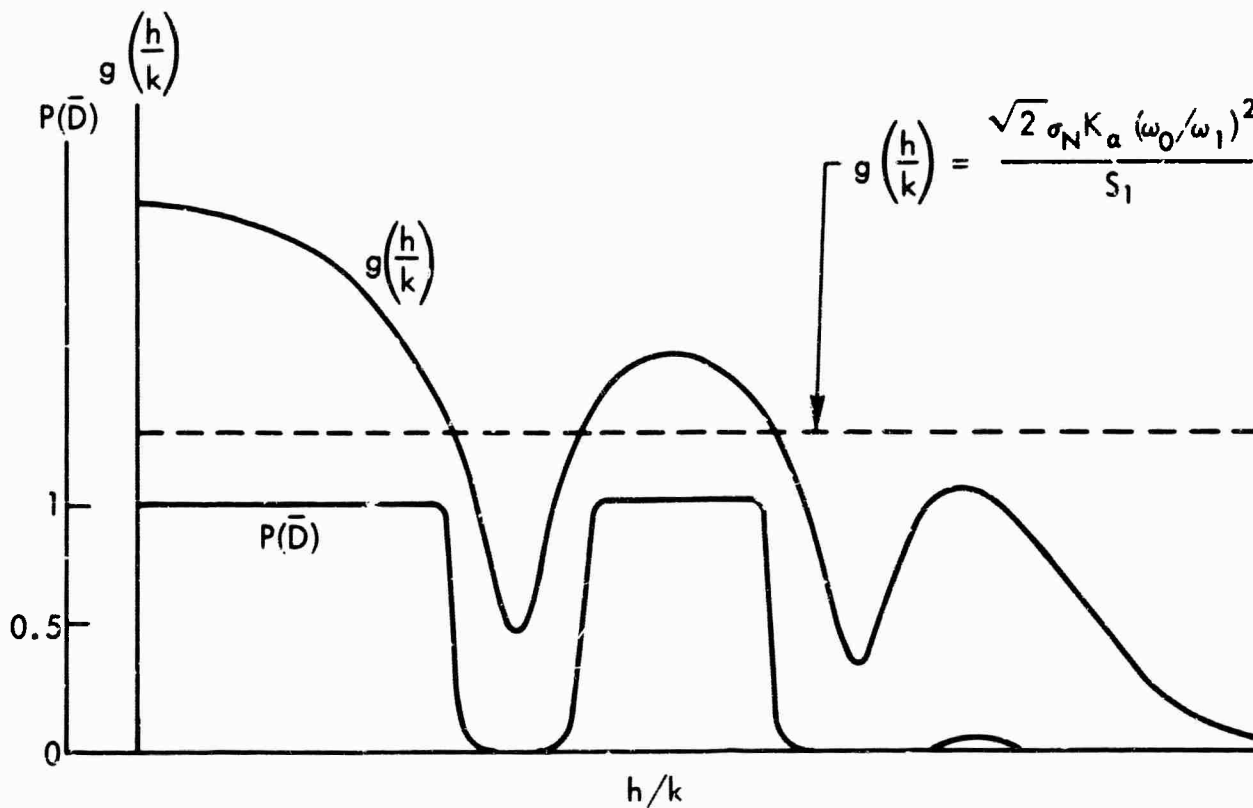

Fig. 15—Average detection probability versus range for arbitrary transmission-loss function $g(h/k)$ and Gaussian noise-level uncertainty

VII. CONCLUSIONS

Several aspects of the problem of detecting a submarine by a single hydrophone sensor have been considered. The signal emitted by the submarine is assumed to consist of broadband noise only, and under this condition, it is clear that the only distinguishing feature the detector can use to decide whether a target is present or not is the increase in noise power caused by the presence of the target. A simple power detector, in which the received power is integrated over the time that the target is within range is therefore essentially equivalent to the optimum detector.

In general, the optimum observation time for a submarine moving past the receiving sonobuoy is inversely proportional to the velocity of the submarine. Hence, if the noise emitted by the submarine were not a function of the velocity, for example, if it consisted exclusively of internally generated machinery noise, a slow submarine would be somewhat more detectable than a fast one. However, even under the unreasonable assumption that the background noise level is known precisely, the detectability index is proportional only to the square root of the observation time, while for the more realistic case of unknown background noise level, the detectability index is practically independent of the observation time. Thus, the increase in detectability resulting from the increased time of observation of the slower submarine is extremely small. On the other hand, the detectability index is directly proportional to the power level of the signal whether the noise level is known precisely or not. Thus, if the noise emitted by the submarine increases at all

with velocity, the increase in signal power will, in practically all cases, result in the faster (and noisier) submarine being more detectable. This is especially true when the background noise level is unknown, in which case this statement is true without any qualification.

The major factor limiting the maximum detectable range is the uncertainty about the level of the background noise level. If this uncertainty is such that the noise level is certain to be somewhere between an upper and a lower bound, then a signal is in effect detectable only if the received power is larger than the maximum conceivable background noise level. In this case, one can define a minimax detection range such that targets at a smaller range are essentially perfectly detectable, while the probability of detection decreases sharply for ranges above this value. If the transmission loss is proportional to the square of the distance, then the minimax detection range is inversely proportional to the square root of the relative noise-level uncertainty. It is clear that the performance of the buoy depends critically on the accurate determination of the noise level.

If it can be assumed that the noise level is constant, it can be estimated within the sonobuoy by making a long-term power measurement of the signal received by the buoy. If the time of this measurement is long compared to the time that target is within range, the average power reading obtained is essentially that of the noise only. This method of estimating the noise level results in an uncertainty that can be approximately described by a Gaussian distribution whose mean is the nominal value of the noise level. There

are then no upper or lower limits on the possible noise level, but detection still depends on the received signal power being substantially greater than one would expect from the noise estimate. Quantitatively, if the transmission loss is inversely proportional to the square of the distance, the detection range is proportional to the square root of the signal power divided by the standard deviation of the noise level.

The suggested method for internally measuring the noise level results in a two-channel detector. One channel incorporates a long-term integrator having a time constant T_0 to estimate the noise. The other one contains a short-term integrator with a time constant $T_1 = 3h/v$, the time that the target is within range. The outputs of the two integrators are compared in order to arrive at a decision as to whether a target is present. This system will generally report any rise in received power lasting for a time on the order of T_1 as a target; it will tend to ignore changes in received power that are either very much longer or very much shorter than T_1 (unless the increased signal power was quite large). The system might, therefore, tend to reduce false alarms that are due to anomalous transmission from very distant targets. On the other hand, short-term changes in the background noise level would result in false alarms. It is difficult to see how any system whose only basis for detection is the short-term change in noise level caused by a target could be made insensitive to the same sort of change by the background noise and still be able to detect targets.

The proposed two-channel detector appears to have certain desirable properties, and qualitatively it probably functions as described. However, it is planned to investigate its performance quantitatively and in more detail.

Appendix A

THE LIKELIHOOD-RATIO DETECTOR FOR DETECTION OF A
GAUSSIAN SIGNAL IN GAUSSIAN NOISE BACKGROUND

Suppose that the received signal has the form

$$x(t) = s(t) + n(t) \quad (\text{A-1})$$

where $s(t)$ is the signal that would be observed if there were no noise, and $n(t)$ is the noise. Both $s(t)$ and $n(t)$ are assumed to be Gaussian random processes with zero mean; hence $x(t)$ is also Gaussian with zero mean. It is always possible to represent such a signal by a set of samples

$$\underline{X}' = [x_1 x_2 x_3 \cdots x_n] \quad (\text{A-2})$$

where the prime denotes the transpose. The kind of samples that are used depends on the application. In some cases time samples are convenient, i.e., $x_1 = x(t_1)$, $x_2 = x(t_2)$, etc. In other cases it is more convenient to expand $x(t)$ in a Fourier series over the observation interval T . In that case the elements of \underline{X} can be considered to be the Fourier coefficients. In either case the elements of \underline{X} are Gaussian random variables with zero mean.

In view of the equivalence between the samples and the continuous function, one can say that the probability of a particular realization of $x(t)$ is the joint probability that the set of samples acquires the particular value yielding this realization. Thus, suppose that the received signal consists of noise only. The covariance matrix of the elements of the sample vector \underline{X} is defined by

$$\langle \underline{X} \underline{X}' \rangle_N = \underline{Q} \quad (\text{A-3})$$

where the symbol $\langle \rangle_N$ represents the statistical average of the quantity in the bracket conditional on the hypothesis indicated by the subscript, and where \underline{Q}^{-1} is assumed to exist. Then the probability density of $\underline{x}(t)$, given that signal is absent, is the probability density of \underline{X} given that signal is absent, which is

$$p_0(\underline{X}) = \frac{1}{(2\pi)^{n/2} [\det \underline{Q}]^{1/2}} \exp\left\{-\frac{1}{2} \underline{X}' \underline{Q}^{-1} \underline{X}\right\} \quad (\text{A-4})$$

The covariance matrix of \underline{X} for $\underline{x}(t) = s(t)$ is defined by

$$\langle \underline{X} \underline{X}' \rangle_S = \underline{P} \quad (\text{A-5})$$

Since signal and noise are independent, the covariance matrix for \underline{X} if signal and noise are both present is

$$\langle \underline{X} \underline{X}' \rangle_{S+N} = \underline{P} + \underline{Q}$$

Then the probability density of $\underline{x}(t)$ given that signal and noise are both present is

$$p_1(\underline{X}) = \frac{1}{(2\pi)^{n/2} [\det (\underline{P} + \underline{Q})]^{1/2}} \exp\left\{-\frac{1}{2} \underline{X}' (\underline{P} + \underline{Q})^{-1} \underline{X}\right\} \quad (\text{A-6})$$

The likelihood ratio is defined as the ratio of $p_1(\underline{X})$ to $p_0(\underline{X})$. It is therefore given by

$$L(\underline{X}) = \frac{p_1(\underline{X})}{p_0(\underline{X})} = \left[\frac{\det \underline{Q}}{\det (\underline{P} + \underline{Q})} \right]^{1/2} \exp\left\{-\frac{1}{2} \underline{X}' [(\underline{P} + \underline{Q})^{-1} - \underline{Q}^{-1}] \underline{X}\right\} \quad (\text{A-7})$$

In practice it is generally reasonable to assume that the input signal-to-noise ratio is very small, so that the elements of the \underline{P} matrix are all very much smaller than the corresponding elements of the \underline{Q} matrix. Then the ratio of the determinants in Eq. (A-7) is approximately unity. Also, the exponent may be expanded as follows

$$\begin{aligned}
 -\frac{1}{2} \underline{X}' [\underline{P} + \underline{Q}]^{-1} \underline{X} &= -\frac{1}{2} \underline{X}' \underline{Q}^{-1} [(\underline{I} + \underline{P}\underline{Q}^{-1})^{-1} - \underline{I}] \underline{X} \\
 &= -\frac{1}{2} \underline{X}' \underline{Q}^{-1} [\underline{I} - \underline{P}\underline{Q}^{-1} + (\underline{P}\underline{Q}^{-1})^2 - \\
 &\quad \dots - \underline{I}] \underline{X} \tag{A-8} \\
 &= \frac{1}{2} \underline{X}' \underline{Q}^{-1} \underline{P}\underline{Q}^{-1} \underline{X} - \frac{1}{2} \underline{X}' \underline{Q}^{-1} \underline{P}\underline{Q}^{-1} \underline{P}\underline{Q}^{-1} \underline{X} \dots \dots
 \end{aligned}$$

where \underline{I} is the unit matrix.

If the signal and noise are "white noise," (i.e., with uniform power spectrum) then $\underline{P} = S\underline{I}$ and $\underline{Q} = N\underline{I}$, where S and N are the signal and noise power respectively. Then $\underline{Q}^{-1} \underline{P}\underline{Q}^{-1} = \frac{1}{N} \left(\frac{S}{N} \right) \underline{I}$; $\underline{Q}^{-1} \underline{P}\underline{Q}^{-1} \underline{P}\underline{Q}^{-1} = \frac{1}{N} \left(\frac{S}{N} \right)^2 \underline{I}$; etc. Hence, the magnitude of the higher-order terms in Eq. (A-8) decreases with S/N , and for small S/N only the first term needs to be considered. If \underline{X} is not "white noise," the higher-order terms are still negligible, but the demonstration of this fact is somewhat more difficult.

Generally, it is more convenient to deal with the logarithm of the likelihood ratio than with the ratio itself. This causes no

difficulty since the logarithm is a monotonic function so that if the likelihood ratio exceeds a given threshold, its logarithm exceeds a different threshold. For small signal-to-noise ratio, the above discussion indicates that

$$\log L(\underline{X}) \approx U = \frac{1}{2} \underline{X}' \underline{Q}^{-1} \underline{P} \underline{Q}^{-1} \underline{X} \quad (\text{A-9})$$

The quantity U is the test statistic of the problem, and it is compared to the threshold U_0 to decide whether or not a signal is present. It is essentially the quantity that must be computed by the optimum receiver. Although the likelihood ratio is a ratio of probability densities, U is obtained from \underline{X} by a deterministic transformation of the vector \underline{X} representing the received signal. U is a random variable because the vector \underline{X} is a random variable.

If $U > U_0$ the decision is that a signal is present. The conditional false-alarm probability α is therefore the probability that the random variable U exceeds the threshold U_0 , given that the signal is actually absent, i.e.

$$\alpha = \int_{U_0}^{\infty} p_0(U) dU \quad (\text{A-10})$$

where $p_0(U)$ is the conditional probability density of U when there is no signal. Similarly, the conditional probability of a correct detection, $(1-\beta)$, is given by

$$(1-\beta) = \int_{U_0}^{\infty} p_1(U) dU \quad (\text{A-11})$$

where $p_1(U)$ is the probability density of U when there is a signal present.

In order to evaluate α and $(1-\beta)$, $p_0(U)$ and $p_1(U)$ must be computed. This is in general rather difficult because the transformation given in Eq. (A-9) is nonlinear. If the matrix $\underline{Q}^{-1}\underline{P}\underline{Q}^{-1}$ equalled $\underline{D}\underline{I}$, where \underline{D} is a constant and \underline{I} is the unit matrix, U would reduce to the sum of squares of the elements of \underline{X} . Then, since \underline{X} is a Gaussian vector, the probability density of U would be a chi-square density in $n = 2TW$ degrees of freedom.* For general $\underline{Q}^{-1}\underline{P}\underline{Q}^{-1}$, the probability density of U is what Middleton** refers to as a "generalized chi-square" density. It can, however, be shown (Ref. 1, Section 17.2-1, and Ref. 8, Section 20.2) that if n is large, and if the eigenvalues of the matrix $\underline{Q}^{-1}\underline{P}\underline{Q}^{-1}$ are small (which means, in effect, that the signal-to-noise ratio is small), both $p_0(U)$ and $p_1(U)$ approach the Gaussian form. Both of these conditions would normally be expected to hold very well for problems of interest here. It therefore will be assumed that $p_0(U)$ and $p_1(U)$ are, in fact, Gaussian.

A Gaussian distribution is completely determined by its mean and variance. The mean μ_0 of $p_0(U)$ is given by

$$\mu_0 = \frac{1}{2} \left\langle \underline{X}' \underline{Q}^{-1} \underline{P} \underline{Q}^{-1} \underline{X} \right\rangle_N = \frac{1}{2} \sum_{i=1}^n \sum_{j=1}^n a_{ij} \left\langle x_i x_j \right\rangle_N \quad (\text{A-12})$$

where a_{ij} is the general element of $\underline{Q}^{-1}\underline{P}\underline{Q}^{-1}$. However, $\left\langle x_i x_j \right\rangle_N = q_{ij}$, the general element of \underline{Q} , by definition. Also, it can be shown⁽⁹⁾

that the double sum $\sum_i \sum_j b_{ij} c_{ij}$ of the product of all the elements of the two matrices \underline{B} and \underline{C} is equal to the sum of the diagonal terms, or trace, of the product matrix \underline{BC} , written $\text{tr}(\underline{BC})$. Hence

* See Ref. 8, Section 18.1.

** See Ref. 1, Section 17.2-1.

$$\begin{aligned} \mu_0 &= \frac{1}{2} \sum_{i=1}^u \sum_{j=1}^u a_{ij} q_{ij} = \frac{1}{2} \text{tr}(\underline{Q}^{-1} \underline{P} \underline{Q}^{-1} \underline{Q}) \\ &= \frac{1}{2} \text{tr}(\underline{Q}^{-1} \underline{P}) = \frac{1}{2} \text{tr}(\underline{P} \underline{Q}^{-1}) \end{aligned} \quad (\text{A-13})$$

Similarly, one finds that the variance of U , given that noise only is present

$$\begin{aligned} \sigma_0^2 &= \frac{1}{4} \left\langle (\underline{X}' \underline{Q}^{-1} \underline{P} \underline{Q}^{-1} \underline{X})^2 \right\rangle_N - \frac{1}{4} \left\langle \underline{X}' \underline{Q}^{-1} \underline{P} \underline{Q}^{-1} \underline{X} \right\rangle_N^2 \\ &= \frac{1}{4} \sum_{i=1}^n \sum_{j=1}^n \sum_{k=1}^n \sum_{l=1}^n a_{ij} a_{kl} \left\langle x_i x_j x_k x_l \right\rangle_N - \frac{1}{4} [\text{tr}(\underline{P} \underline{Q}^{-1})]^2 \end{aligned} \quad (\text{A-14})$$

where the a_{ij} and a_{kl} are again general elements of $\underline{Q}^{-1} \underline{P} \underline{Q}^{-1}$. Since the x_i are Gaussian variables, one can expand the quadruple average into products of covariances.⁽¹⁰⁾ Therefore

$$\begin{aligned} &\sum_{i=1}^n \sum_{j=1}^n \sum_{k=1}^n \sum_{l=1}^n a_{ij} a_{kl} \left\langle x_i x_j x_k x_l \right\rangle_N \\ &= \sum_{i=1}^n \sum_{j=1}^n \sum_{k=1}^n \sum_{l=1}^n a_{ij} a_{kl} \left[\left\langle x_i x_j \right\rangle_N \left\langle x_k x_l \right\rangle_N \right. \\ &\quad \left. + \left\langle x_i x_k \right\rangle_N \left\langle x_j x_l \right\rangle_N + \left\langle x_i x_l \right\rangle_N \left\langle x_j x_k \right\rangle_N \right] \end{aligned}$$

Thus

$$\begin{aligned}
 & \sum_{i=1}^n \sum_{j=1}^n \sum_{k=1}^n \sum_{l=1}^n a_{ij} a_{kl} \left\langle x_i x_j x_k x_l \right\rangle_N \\
 &= \left[\sum_{i=1}^n \sum_{j=1}^n a_{ij} \left\langle x_i x_j \right\rangle_N \right]^2 \\
 &\quad + 2 \sum_{i=1}^n \sum_{j=1}^n \sum_{k=1}^n \sum_{l=1}^n a_{ij} a_{kl} \left\langle x_i x_k \right\rangle_N \left\langle x_j x_l \right\rangle_N \\
 &= \left[\text{tr } \underline{PQ}^{-1} \right]^2 + 2 \text{tr} \left[(\underline{PQ}^{-1})^2 \right] \tag{A-15}
 \end{aligned}$$

Finally

$$\sigma_o^2 = \frac{1}{2} \text{tr} \left[(\underline{PQ}^{-1})^2 \right] \tag{A-16}$$

Similarly, it can be shown that the mean μ_1 of $p_1(U)$ is given by

$$\mu_1 = \frac{1}{2} \left\langle \underline{X}' \underline{Q}^{-1} \underline{PQ}^{-1} \underline{X} \right\rangle_{S+N} = \frac{1}{2} \text{tr} \left[(\underline{PQ}^{-1})^2 \right] + \frac{1}{2} \text{tr}(\underline{PQ}^{-1}) \tag{A-17}$$

and

$$\begin{aligned}
 \sigma_1^2 &= \frac{1}{2} \text{tr} \left[(\underline{PQ}^{-1})^2 (\underline{I} + \underline{PQ}^{-1})^2 \right] \\
 &\approx \frac{1}{2} \text{tr} \left[(\underline{PQ}^{-1})^2 \right] = \sigma_o^2 \tag{A-18}
 \end{aligned}$$

where the approximation implies, as before, that the signal-to-noise ratio is small so that the elements of \underline{PQ}^{-1} are all very much less than unity.

From Eqs. (A-10), (A-13), and (A-16), the false-alarm probability is found to be

$$\alpha = \frac{1}{2} - \frac{1}{2} \Theta \left(\frac{U_0 - \frac{1}{2} \text{tr}(\underline{PQ}^{-1})}{\sqrt{\text{tr}[(\underline{PQ}^{-1})^2]}} \right) \quad (\text{A-19})$$

where

$$\Theta(z) = \frac{2}{\sqrt{\pi}} \int_0^z e^{-t^2} dt$$

Similarly, from Eqs. (A-11), (A-17), and (A-18), the probability of a correct detection is

$$(1-\beta) = \frac{1}{2} - \frac{1}{2} \Theta \left[\frac{U_0 - \frac{1}{2} \text{tr}(\underline{PQ}^{-1})}{\sqrt{\text{tr}[(\underline{PQ}^{-1})^2]}} - \frac{1}{2} \sqrt{\text{tr}[(\underline{PQ}^{-1})^2]} \right] \quad (\text{A-20})$$

Comparison of the arguments of the Θ functions in the two cases indicates that the difference is the quantity $d/\sqrt{2}$, where

$$d = \sqrt{\frac{1}{2} \text{tr}[(\underline{PQ}^{-1})^2]} \quad (\text{A-21})$$

d is referred to as the "detection index" and may be considered as the figure of merit of the detection system. For a given false-alarm probability which fixes $\left[U_0 - \frac{1}{2} \text{tr}(\underline{PQ}^{-1}) \right] / \sqrt{\text{tr}[(\underline{PQ}^{-1})^2]}$, the larger d is, the greater is the probability of true detection. Inspection of Eqs. (A-13), (A-16), and (A-17) indicates that

$$d = \frac{\mu_1 - \mu_0}{\sigma_0} \quad (\text{A-22})$$

The optimum receiver forms U from $x(t)$ according to Eq. (A-9).

One can think of μ_1 and μ_0 as the "dc" component of the output under

the hypothesis that the signal is present or absent respectively, and $\sigma_0 \approx \sigma_1$ is the rms fluctuation of U . Then d is the ratio of the difference of useful output from the detector to the output fluctuation, i.e., it is like an output signal-to-noise ratio. This suggests that this same figure of merit be used in evaluating sub-optimum systems.

Appendix B

DETECTION WHEN SIGNAL OR NOISE POWER IS UNKNOWN

In the previous discussion it has been tacitly assumed that the signal power and noise power are known; otherwise the matrices \underline{P} and \underline{Q} , which are proportional to signal and noise power respectively, could not be completely determined. In practice neither of these power levels would be known exactly.

Consider first the problem of unknown signal power. It seems clear on heuristic grounds that the false-alarm probability α should not be a function of the signal power, and this is corroborated by statements in the literature.* However, it appears from Eq. (A-19) that α does depend on both \underline{P} and \underline{Q} and, therefore, on both signal and noise power. In order to resolve this apparent discrepancy, we note that the test statistic U defined in Eq. (A-9) is generated from the received signal by means of a processor which in some way realizes the matrix operation $\underline{Q}^{-1}\underline{P}\underline{Q}^{-1}$. Since the elements of \underline{P} are proportional to the signal power S , the "gain" of the processor is proportional to S . This is the only reason why U is proportional to S ; the received signal $x(t)$ (consisting of noise only) has nothing to do with it. The threshold U_0 for a desired false-alarm probability therefore also depends on S only because the gain of the processor does. If the processor gain is arbitrarily changed, the false-alarm probability α will remain unchanged if the threshold U_0 is changed in the same proportion as the processor gain. Thus, it is possible to base both the processor gain and the threshold on a normalized \underline{P} matrix, i.e.,

* See Ref. 2, pp. 133-134.

to set

$$\underline{P} = S p$$

and

(B-1)

$$U_o = S U'_o$$

Substitution of Eq. (B-1) into Eq. (A-19) then indicates that α is independent of S.

This same argument does not hold for unknown noise level. In order to show this, suppose that the matrix Q is also normalized, i.e.

$$Q = N q \quad (B-2)$$

and that a test statistic u is formed by a normalized processor $q^{-1} p q^{-1}$ which is now independent of both signal and noise power, i.e.

$$u = \frac{1}{2} \underline{X}' q^{-1} p q^{-1} \underline{X} \quad (B-3)$$

It is easily seen that for $x(t)$ consisting of noise only, both the mean and standard deviation of u are proportional to N through the received signal vector \underline{X} . If u is compared to the threshold u_o , the false-alarm probability is given by

$$\alpha = \frac{1}{2} - \frac{1}{2} \Theta \left[\frac{u_o - \frac{1}{2} N \text{tr}(p q^{-1})}{N \sqrt{\text{tr}[(p q^{-1})^2]}} \right] \quad (B-4)$$

This is clearly dependent on N . The noise level cannot be normalized out because it depends on the received signal rather than being simply a gain adjustment in the processor as is the signal level.

Suppose now that the received signal $x(t)$ consists of noise with a known power level N , and signal with an unknown power level S , and that this signal is processed through a normalized processor as in Eq. (B-3). For small signal-to-noise ratio (which can be assumed to exist even though the exact signal power is not known), the variance of u is the same as with noise only present. However, the change in the mean due to the presence of the signal is now

$$\langle u \rangle_{S+N} - \langle u \rangle_N = \frac{1}{2} S \operatorname{tr}(pq^{-1})^2 \quad (\text{B-5})$$

Therefore, the detection index d now takes the form

$$d = \frac{S}{N} \sqrt{\frac{1}{2} \operatorname{tr}(pq^{-1})^2} \quad (\text{B-6})$$

and Eq. (A-20) for the probability of correct detection is changed to

$$(1-P) = \frac{1}{2} - \frac{1}{2} \Theta \left[k(\alpha) - \frac{1}{2} \frac{S}{N} \sqrt{\operatorname{tr}(pq^{-1})^2} \right] \quad (\text{B-7})$$

where

$$k(\alpha) = \frac{u_0 - \frac{1}{2} N \operatorname{tr}(pq^{-1})}{N \sqrt{\operatorname{tr}(pq^{-1})^2}} \quad (\text{B-8})$$

is the argument of the error function defining α .

It should be noted that although in this discussion the matrices P and Q were normalized with respect to total signal and noise power, any other normalization proportional to signal and noise power would yield identical results.

REFERENCES

1. Middleton, D., Introduction to Statistical Communication Theory, McGraw-Hill Book Company, Inc., New York, 1960.
2. Helstrom, C. W., Statistical Theory of Signal Detection, Pergamon Press, New York, 1960.
3. Albers, V. M., Underwater Acoustics Handbook, The Pennsylvania State University Press, University Park, 1960, Chap. 7.
4. Rice, S. O., "Mathematical Analysis of Random Noise," Bell System Technical Journal, Vol. XXIII, No. 3, July 1944, p. 329.
5. Zadeh, L. A. and J. R. Ragazzini, "Optimum Filters for the Detection of Signals in Noise," Proc. IRE, Vol. 40, No. 10, October 1952, pp. 1223-1231.
6. Wenz, G. M., "Acoustic Ambient Noise in the Ocean: Spectra and Sources," JASA, Vol. 34, No. 12, December 1962, pp. 1936-1956.
7. Chang, S. S. L., Synthesis of Optimum Control Systems, McGraw-Hill Book Company, Inc., New York, 1961, Appendix D.
8. Cramér, H., Mathematical Methods of Statistics, Princeton University Press, Princeton, N.J., 1946.
9. Margenau, H., and G. M. Murphy, The Mathematics of Physics and Chemistry, D. Van Nostrand Company, Inc., Princeton, N.J., 1959, Vol. 1, p. 309.
10. Laning, J. H., Jr., and R. H. Battin, Random Processes in Automatic Control, McGraw-Hill Book Company, Inc., New York, 1956, p. 83.