

AD610255

AMRL-TT. 64-87

ADVANCED SELECTIVE MONITORING SYSTEMS

A. BABICH
G. MORTON

AIRBORNE INSTRUMENTS LABORATORY
A DIVISION OF CUTLER-HAMMER, INC.

COPY	2	OF	3	TR
HARD COPY			\$.	2.00
MICROFICHE			\$.	0.50

52P

NOVEMBER 1964

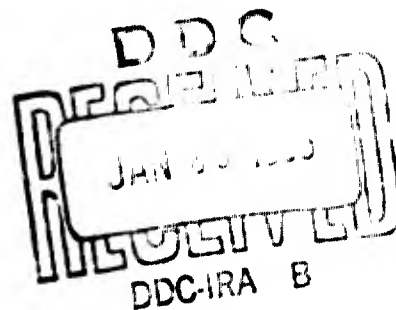

BIOPHYSICS LABORATORY
AEROSPACE MEDICAL RESEARCH LABORATORIES
AEROSPACE MEDICAL DIVISION
AIR FORCE SYSTEMS COMMAND
WRIGHT-PATTERSON AIR FORCE BASE, OHIO

ARCHIVE COPY

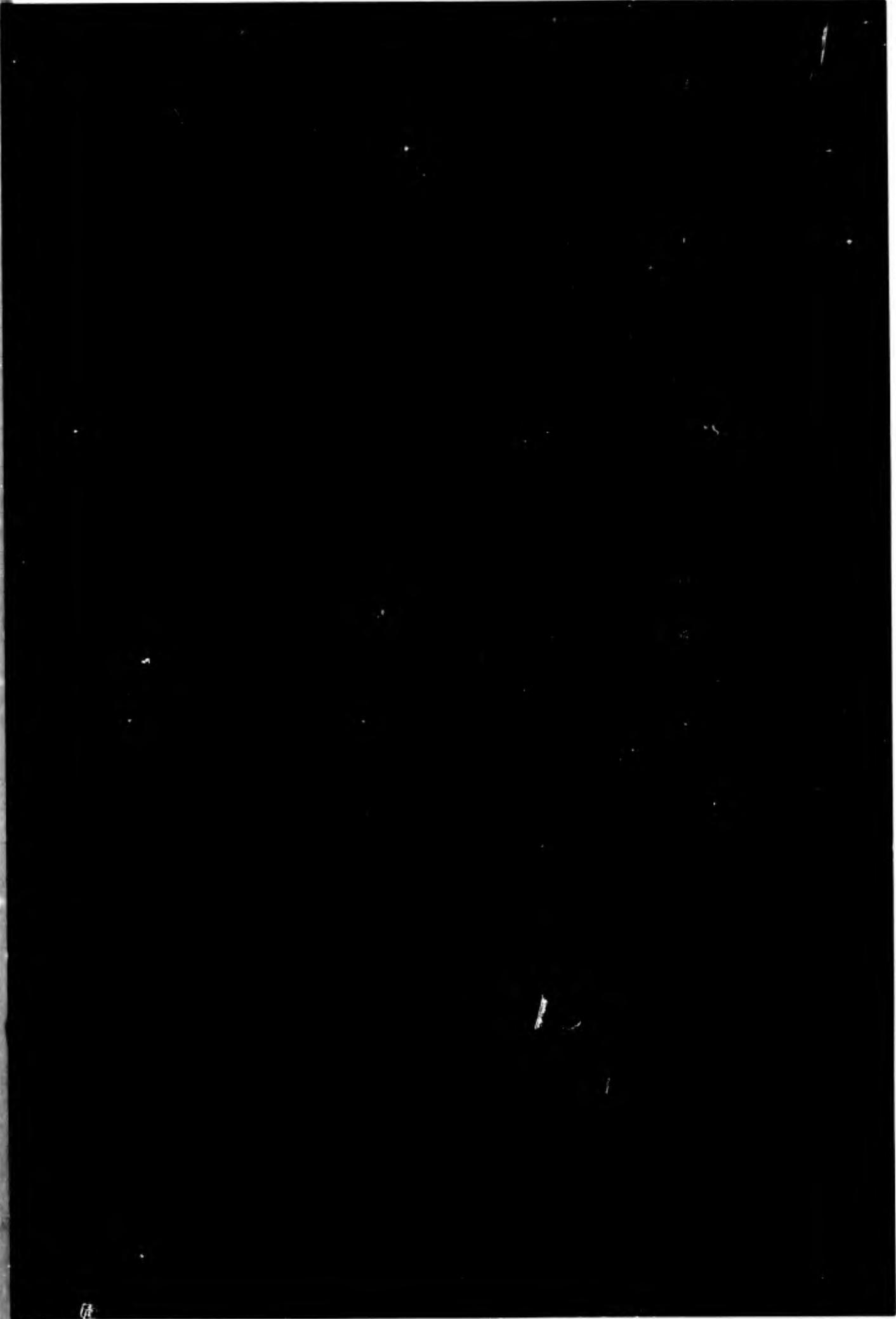

78

2

NOTICES

When US Government drawings, specifications, or other data are used for any purpose other than a definitely related Government procurement operation, the Government thereby incurs no responsibility nor any obligation whatsoever, and the fact that the Government may have formulated, furnished, or in any way supplied the said drawings, specifications, or other data, is not to be regarded by implication or otherwise, as in any manner licensing the holder or any other person or corporation, or conveying any rights or permission to manufacture, use, or sell any patented invention that may in any way be related thereto.

Qualified requesters may obtain copies from the Defense Documentation Center (DDC), Cameron Station, Alexandria, Virginia 22314. Orders will be expedited if placed through the librarian or other person designated to request documents from DDC (formerly ASTIA).

Stock quantities available, for sale to the public, from:

Chief, Input Section
Clearinghouse for Federal Scientific and Technical Information, CFSTI
Sills Building
5285 Port Royal Road
Springfield, Virginia 22151

Change of Address

Organizations and individuals receiving reports via the Aerospace Medical Research Laboratories' automatic mailing lists should submit the addressograph plate stamp on the report envelope or refer to the code number when corresponding about change of address or cancellation.

Do not return this copy. Retain or destroy.

TI

ng

BLANK PAGE

ADVANCED SELECTIVE MONITORING SYSTEMS

*A. BABIC!
G. MORTON*

FOREWORD

This study was initiated by the Biophysics Laboratory of the Aerospace Medical Research Laboratories, Aerospace Medical Division, Air Force Systems Command, Wright-Patterson Air Force Base, Ohio. The research was conducted by the Airborne Instruments Laboratory, a Division of Cutler-Hammer, Inc, Deer Park, Long Island, New York, under Contract No. AF 33(657)-10462 with Mr. George W. Morton as principal investigator. Adolf R. Marko, PhD of the Environmental Stress Branch, Multienvironment Division, was the contract monitor for the Aerospace Medical Research Laboratories. The work was performed in support of Project No. 7222, "Biophysics of Flight," Task No. 722203, "Bioinstrumentation." The research sponsored by this contract is a continuation of previous study on data gathering systems developed under Contract No. AF 33(616)-8370, described in Technical Documentary Report No. AMRL-TDR-62-144. This research was started in January 1963 and completed in June 1964.

This technical report has been reviewed and is approved.

J. W. HEIM
Technical Director
Biophysics Laboratory

ABSTRACT

In order to reduce the amount of data obtained in multiple-input data acquisition systems--subsequently reducing power and size requirements in space vehicles, or reducing processing time in a computer analysis--a Selective Monitoring System was built and tested. The present system is an extension of a laboratory model which was used as criteria for signal selection signal changes from a steady state and signal excursions beyond predetermined limits. That system (laboratory model) was expanded to include originating (encoding) and terminal (decoding) equipment for a PCM data-transmission channel. The encoding and decoding equipment used the selective-monitoring characteristics of the laboratory model to obtain a data transmission rate lower than that required in an ordinary multiple input data acquisition system. Signals selected by the encoder unit were reconstructed in the decoder unit. A rate analog processor, compatible with the Selective Monitoring System, and suitable for use as a cardiometer, was built and tested. Performance requirements in an operational system are described. The reduction in size and power consumption obtainable with microminiaturization is analyzed.

TABLE OF CONTENTS

	<u>Page</u>
I. Introduction	1
Phase I	2
Phase II	3
Phase III	3
II. Description of Selective Monitoring System	5
III. Monitoring Techniques	9
Limit Detection	10
Level-Change Detection	10
Combined Limit- and Level-Change Selection	12
Self-Check Cycle	12
IV. Data Formatter	13
V. Decoder	17
VI. Rate Analog Processor	19
VII. Monitoring of Rate Analog Output	25
VIII. Performance Requirements of Operational System	27
Command System	27
Telemetry System	28
Synchronization of Encoder and Decoder	32

	<u>Page</u>
IX. Microminiaturized Circuits	37
Thin-Film Integrated Circuitry	37
Semiconductor Integrated Circuitry	37
Characteristics of Microminiaturized Selective Monitoring System	38
X. Performance Testing of Selective Monitoring System	41
XI. Summary and Conclusions	45

LIST OF ILLUSTRATIONS

<u>Figure</u>		<u>Page</u>
1	Selective Monitoring System	viii
2	Block Diagram of Selective Monitoring System	6
3	Clock and Data Word Formats	6
4	Encoder Selection Circuits and Analog-to-Digital Converter	8
5	Operation of Digital Level-Change Selection Logic	11
6	Block Diagram of Digital Multichannel Level-Change Selection Circuit	11
7	Encoder Data Formatter	14
8	Decoder	18
9	Rate Analog Processor	20
10	Rate Analog Processor Timing	20
11	Logarithmic Amplifier	22
12	Block Diagram of 1/T Computer	22
13	Operation of 1/T Computer	23
14	2-Channel and 1-Channel Data Words	34
15	Phase-Locked Loop Detector	34
16	System Outputs	42
17	Rate Analog Processor Frequency Response	43

LIST OF TABLES

<u>Table</u>		<u>Page</u>
1	Digital Module Count	39

ENCODER



DECODER

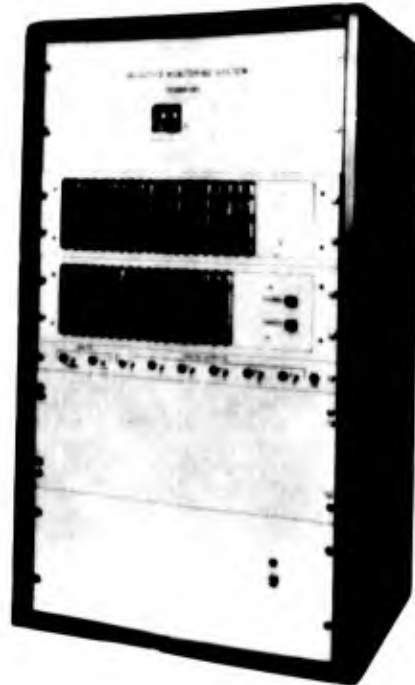

**RATE ANALOG
PROCESSOR**

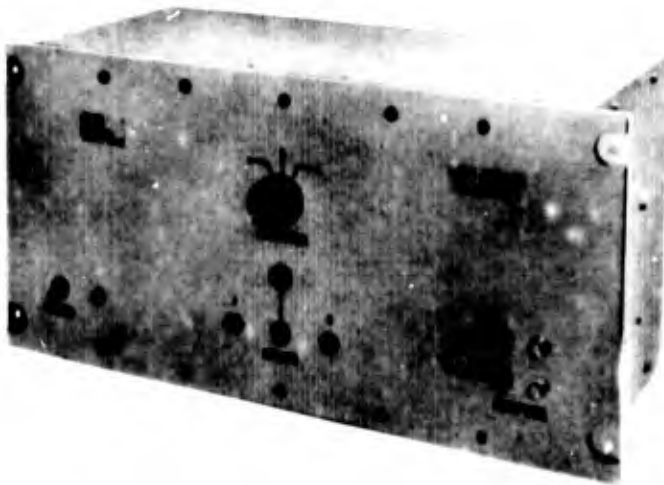

FIGURE 1. SELECTIVE MONITORING SYSTEM

BLANK PAGE

I. INTRODUCTION

Selective Monitoring is a term applied to the operation of multiple-input data-acquisition systems that reject redundant or unnecessary information and produce as outputs only the portion of the input data that has certain predetermined characteristics. The output of a selective monitoring system will generally be a time division multiplexed information channel that can be used in a telemetry link or a computer-compatible data output.

Selective-monitoring techniques are becoming increasingly important to space telemetry and computer processing, because of the large volume of data accumulated even in relatively simple space-vehicle monitoring systems or ordinary ground-based monitoring systems. This large volume of data in a telemetry link requires a wider transmission bandwidth with the subsequent disadvantages of greater power consumption and increased size. In computer processing, more time and more complicated computer programs are required to process the data.

The study of a data-acquisition system that discriminates against signals that do not contain new information has therefore been investigated. Signals that go through long periods of time during which little or no change occurs in their characteristics are examples of redundant signals; they are commonly found in airborne and ground monitoring. For example, most physiological signals have this property.

Airborne Instruments Laboratory (AIL) previously constructed and tested a laboratory model selective monitoring system.* This system selected up to six analog input signals on the basis of two desired criteria in a practical data-acquisition system. These criteria were:

1. Selection on the basis of a change in signal level expressed as a percentage of full scale,
2. Selection on the basis of signal excursion beyond predetermined upper or lower limits.

*The development of this system reported by Morton, G. W., and A. I. Ligorner, Study and Development of a Selective Monitoring System, Aerospace Medical Research Laboratories, Report No. AMRL-TDR-62-144, AD 295 589, Wright-Patterson Air Force Base, Ohio, December 1962.

Under the present investigation, the selective monitoring system has been expanded to include a data-formatting unit that organizes and multiplexes the selected information for a single-channel telemetry link.

Three phases of work were successfully completed.

PHASE I

The stability characteristics of the selection unit were improved to provide rejection of signals with less than 20 millivolts peak-to-peak amplitude at maximum level selection sensitivity.

Variable delay-on-dropout circuits were added to each channel to provide stable pass conditions on signal rise or fall rates between 0.5 and 30 volts/second.

A formatting device was constructed to multiplex the selected data for single-channel telemetry transmission such that no dead space occurred in the time-division multiplexing if at least one signal input channel was selected. A 2.4-kc clock rate was chosen. In addition, the following operations were included in the data-formatting unit:

1. A programmed selection and self-check mode was incorporated. In this mode, an exponential signal with adjustable rise time is fed to all input signals. The signal covers the 0 to 5 volt input range of the analog inputs. All channels are thus automatically selected during the check cycle if the selection logic is functioning correctly.
2. Provision was made for the insertion of time codes before the transmission of data to identify data with proper time of occurrence.

A companion decoding unit was constructed, which receives the telemetry-link information from the data-formatting unit, identifies and decodes it, and presents it as an analog output. A lower clock speed (400 cps) is provided in the encoder and decoder units to enable the encoded telemetry output to be recorded on a low-bandwidth FM tape recorder. The tape can subsequently be played back into the decoder unit.

PHASE II

Various techniques for extracting a rate analog from physiological signals were investigated and evaluated.*

PHASE III

A rate-analog processor was constructed, based on the Phase II study program, with an output compatible with the selective monitoring system. This device makes it possible to demonstrate the operation of the selective monitoring system with live input data.

* See footnote on p. 1.

BLANK PAGE

II. DESCRIPTION OF SELECTIVE MONITORING SYSTEM

Figure 2 is a block diagram of the Selective Monitoring System developed under Contracts AF 33(657)-10462 and AF 33(616)-8370; it consists of two basic units: an encoder and a decoder.

The encoder performs two functions: analog signal selection (and rejection), and PCM data formatting. All controls governing the operating modes of the system are located in the encoder. A maximum of six analog inputs can be monitored.

The decoder receives the PCM information from the encoder unit, identifies the original encoder input associated with it, and reconstructs the original analog signals at the appropriate one of six analog outputs. Sample-and-hold gates hold the analog output voltages.

The basic clock frequency of the encoder is 2400 cps; the sampling frequency per channel is 400 cps. These frequencies also represent the two possible transmission bit rates in the telemetering link.

A signal sample is transmitted serially as a 12-bit word. Eight bits are a binary representation of the sample, 3 bits are the number of the input signal, and 1 bit is the parity bit. Figure 3 shows the function of each bit in the word.

A separate transmission channel is used for telemetering clock and word synchronization information. Figure 2 shows the voltage levels in the clock channel as they are related to the data channel. When no synchronizing information is received on the clock channel by the decoder, it continues to function at its own clock frequency, which is slightly lower than the encoder telemetering frequency in either the 2400 or 400 cps mode.

The initial lock-up between encoder and decoder occurs a maximum of two word intervals after the encoder begins telemetering data. The first two words sent on the signal channel contain twelve zeroes. This enables the two units to synchronize before any time or input data are sent on the signal channel.

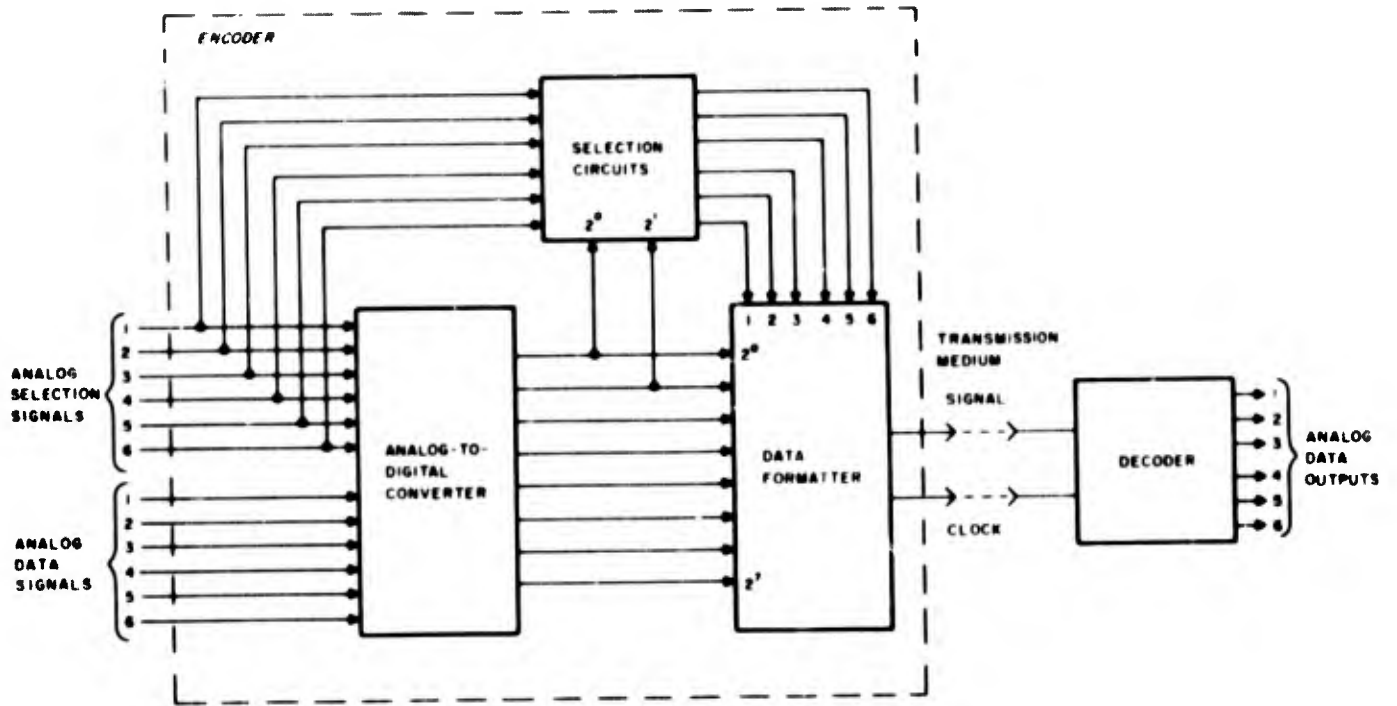

FIGURE 2. BLOCK DIAGRAM OF SELECTIVE MONITORING SYSTEM

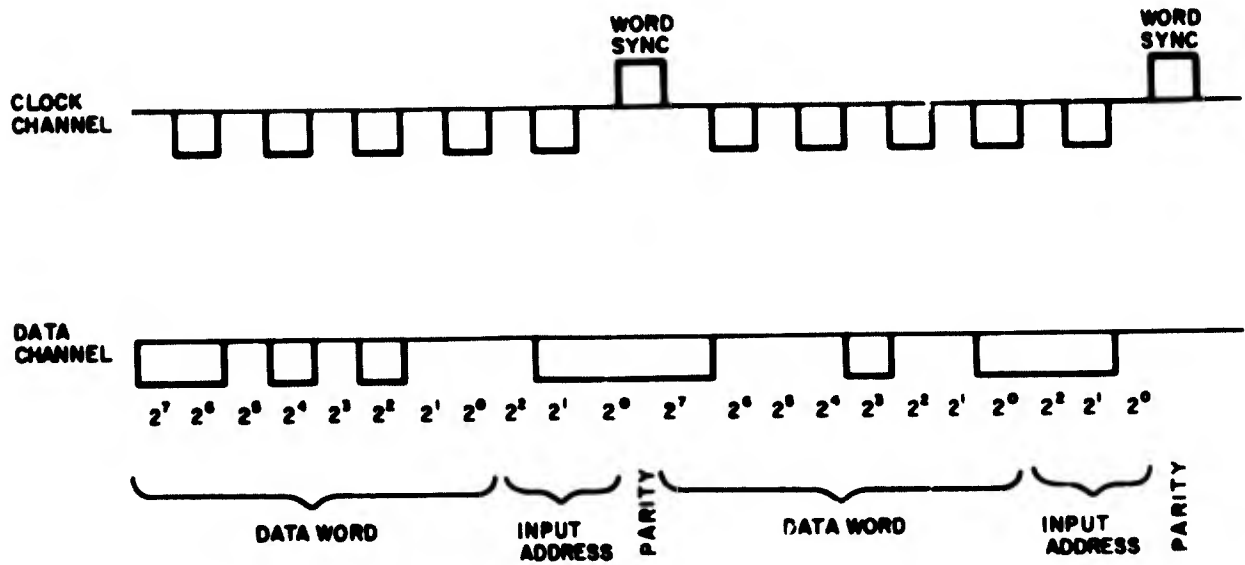

FIGURE 3. CLOCK AND DATA WORD FORMATS

The two words occurring after the first two all-zero words are time code words. Provision has been made for the insertion of two 8-bit codes. The real value of these words, however, is in an operational satellite system where time of occurrence would be important because of the necessity to temporarily store information.

These time codes occur only when the system begins telemetering. If the encoder and decoder are already locked up, no time code words are inserted.

Two input analog multiplexers are used in the selective monitoring system (Figure 4). The first multiplexer is used in the level-change selection process. Each gate in this multiplexer has a continuously variable gain from 0 to 1. The gain setting is used to vary the selection sensitivity. The second multiplexer is used to obtain a binary representation of the full-scale analog input for data transmission or reproduction. Each gate in this multiplexer has a gain of unity. The inputs to these gates can be common or separate, enabling a signal other than the one used in the selection process to be transmitted.

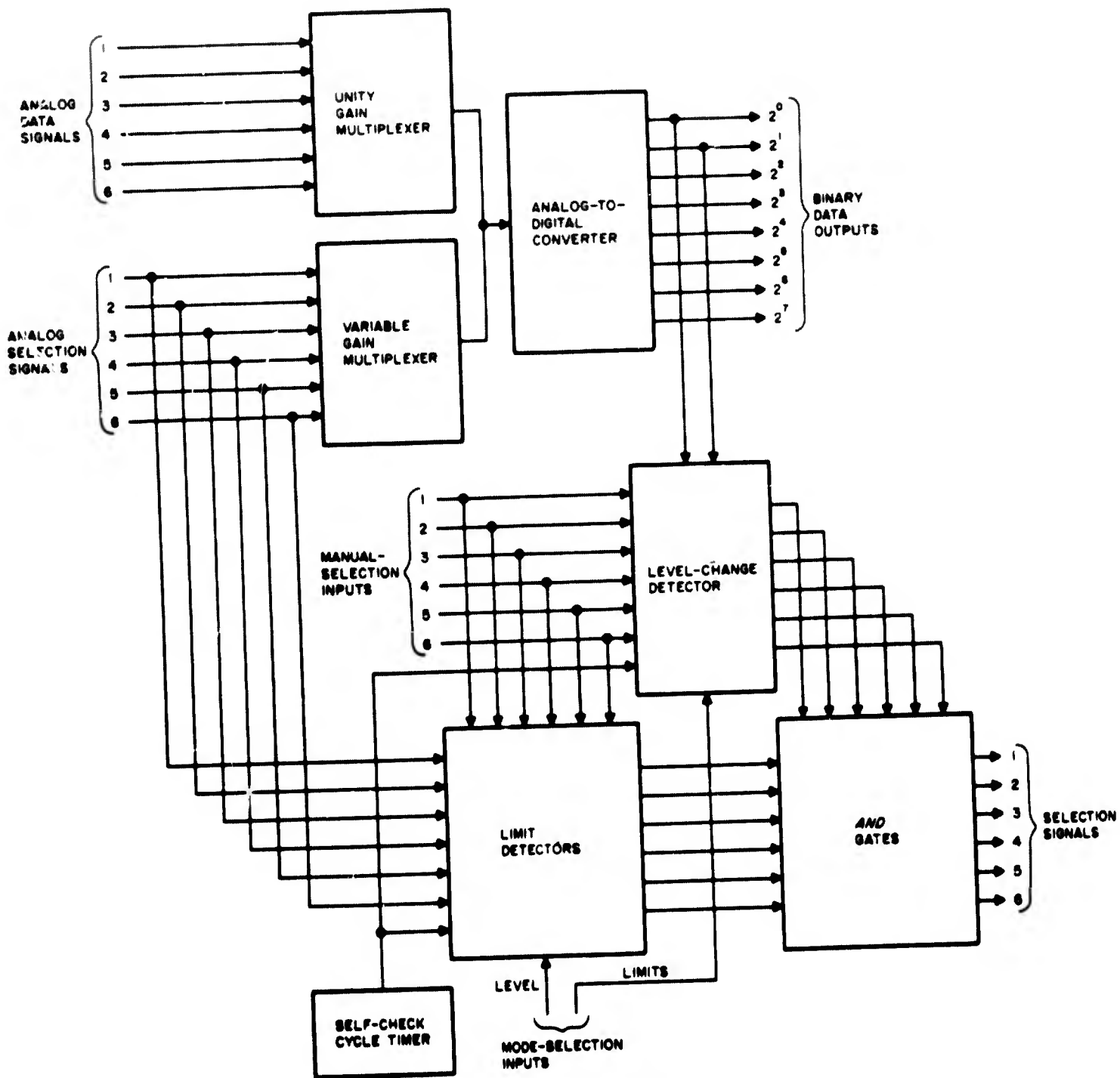

FIGURE 4. ENCODER SELECTION CIRCUITS AND ANALOG-TO-DIGITAL CONVERTER

III. MONITORING TECHNIQUES

The selective monitoring system determines signal selection or rejection from five criteria:

1. Excursion of an analog signal beyond predetermined upper or lower limits,
2. Change in signal level greater than a predetermined percentage of full scale,
3. Change in signal level greater than a predetermined amount only when the signal is beyond predetermined upper or lower limits,
4. Manual operator selection (and inhibit),
5. Program selection determined by a preset timer. A self-check cycle is also initiated by the timer.

These selection criteria are controlled by a MODE SELECTION switch, six individual CHANNEL SELECTION switches, and a mechanical timer that has an adjustable timing interval from 0 to 60 minutes. Figure 4 is a block diagram of the selection circuitry.

The MODE SELECTION switch determines the type of selection criterion that the encoder will use. Its three positions (limit detection, level change detection, and limit and level change detection) enable selection on the basis of criteria 1, 2, and 3.

One CHANNEL SELECTION switch is associated with each analog input and each has three positions: SELECT, NORMAL, and INHIBIT. The MODE SELECTION switch controls the mode of selection of a particular input only when the CHANNEL SELECTION switch associated with that input is in the NORMAL position.

The fifth criterion, program selection, is determined by the mechanical timer, which first initiates a self-check cycle. At the conclusion of this self-check cycle, all channels are selected.

The outputs of the selection circuitry are produced by AND gates. Each AND gate has one input from the level-change detection circuitry and one from the limit-

detection circuitry. Selection indications from both detection circuits are required to produce signal selection. The Limit and Level Change Mode produces signal selection in precisely this manner. In the Limit Mode or Level Change Mode, the selection indication from the level change or limit detection circuitry, respectively, is obtained by manually overriding the circuit outputs with the MODE SELECTION switch.

LIMIT DETECTION

Two threshold detectors that are continuously adjustable over the entire analog input range are used for limit detection in each analog input. This makes it possible for any region of the input-signal range to be rejected by the appropriate selection of upper and lower boundaries of that region.

A selection output from either threshold detector is stored for one clock period--that is, 413 microseconds. If, at the end of this time, the signal has returned to the rejection range, the selection indication is removed.

LEVEL-CHANGE DETECTION

Signal-level changes are detected digitally in the selective monitoring system. The analog signal is quantized and given an 8-bit binary representation, or, equivalently, the signal is represented by 256 quantization levels. The 2 least-significant bits in the binary representation are decoded; this produces four quantization levels independent of the 6 most-significant bits. A level change is recognized when all four quantization levels have been occupied.

Implementation of this idea assumes that the signal does not change by more than one quantization interval between two successive samples. Then, each new quantization level obtained by decoding the 2 least-significant bits is stored in a register. Selection results when four adjacent quantization levels have been occupied (Figure 5). Four adjacent quantization levels cannot be stored if the signal changes at a rate fast enough to skip one or more quantization levels between samples. However, because of the nature of the implementation of the selection criterion, there still remains a high probability of selection in such a case.

Figure 6 illustrates the implementation of the level-change detection process. There are three basic parts to the circuitry: a six-input analog multiplexer, a nine-stage analog-to-digital converter, and a memory register.

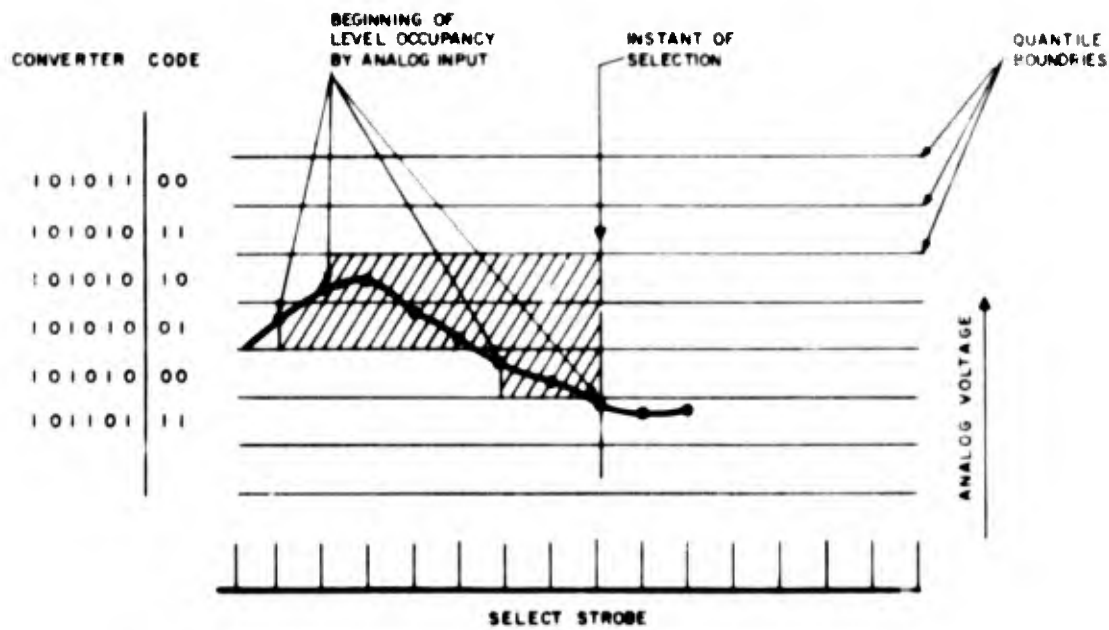

FIGURE 5. OPERATION OF DIGITAL LEVEL-CHANGE SELECTION LOGIC

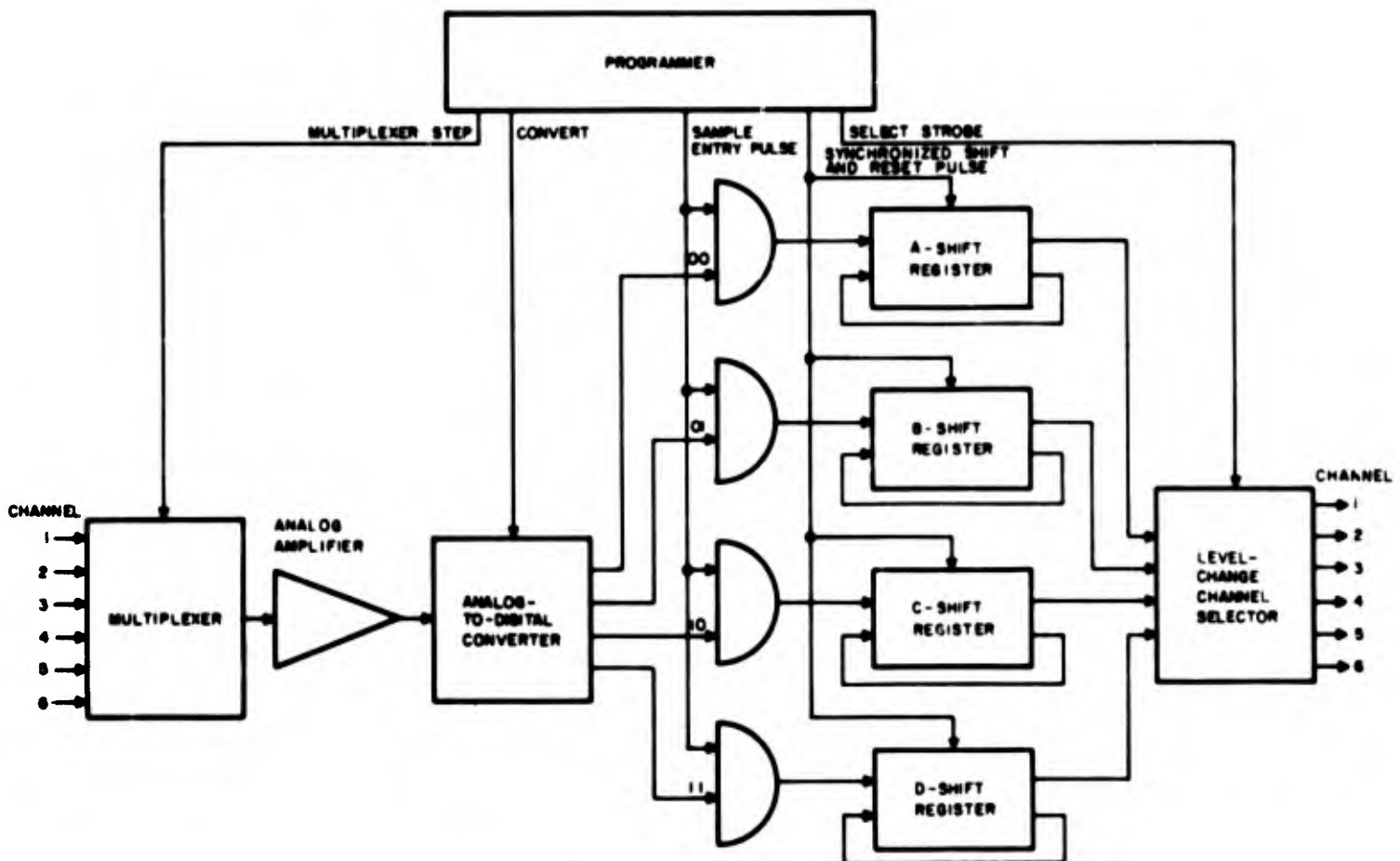

FIGURE 6. BLOCK DIAGRAM OF DIGITAL MULTICHANNEL LEVEL-CHANGE SELECTION CIRCUIT

Quantization levels are produced by the nine-stage analog-to-digital converter. Six analog inputs are multiplexed and fed to the analog-to-digital converter. An indication of four adjacent quantization levels having quantization intervals of $1/256^{\text{th}}$ of full scale is given by the 2^1 and 2^2 stages of the analog-to-digital converter. The four states of these stages can be depicted in binary numbers by 00, 01, 10, 11. Selection is made when all of these states has occurred at least once. Since the six stages of the analog-to-digital converter corresponding to the 6 most-significant bits of the binary number are ignored in the selection process, the level-change detection is independent of the voltage range of the input signal. For this reason, there exists a high probability that even signals that change at a rate faster than one quantization level per sampling interval will eventually be selected. Level-selection sensitivity is adjustable from 0 to 100 percent of full scale. It is accomplished by adjusting the gain of the analog multiplexer gate; this gain is continuously adjustable from 0 to 1.

A level-change indication for any input is stored for a preset period of 1 to 5 seconds. This period is measured from the last level-change indication and can be called a delay-on-dropout. The delay-on-dropout enables continuous selection to be made on signals that change more than three quantization levels within the preset dropout period.

COMBINED LIMIT- AND LEVEL-CHANGE SELECTION

The Limit- and Level-Change Mode incorporates the features of the Level Change Mode and Limit Mode of operation. This mode, however, requires that both criteria be met for signal selection to occur.

SELF-CHECK CYCLE

A self-check cycle is initiated by a mechanical timer with an adjustable timing interval of 0 to 60 minutes. During this cycle, the six analog inputs are disconnected from the input-signal multiplexer. A check signal is connected in place of these inputs.

The check signal used in the laboratory demonstration system is an RC charging curve with a time constant adjustable from 10 to 100 seconds.

IV. DATA FORMATTER

The data formatter encodes and transmits samples of particular data channels as signaled by the level-change and limit-detection circuits of Figure 4. These selected inputs are given an 8-bit binary representation and multiplexed with other selected inputs to produce a PCM signal channel suitable for telemetering. Each signal sample is transmitted as a 12-bit serial binary word. Figure 3 shows the function of each bit in this word.

A companion decoder unit receives the PCM information from the encoder and reconstructs the original analog signals in each of the selected data channels. It converts the 12-bit binary words to analog voltages and reads out these analog voltages in six sample and hold gates corresponding to the original six analog input signals.

Synchronization of encoder and decoder units is achieved by a second synchronizing channel that contains an NRZ clock signal and a word synch. Figure 3 illustrates the relationship of this clock channel to the signal channel.

The normal data-transmission rate of the selective monitoring system is 2.4 kc. A 400-cps transmission rate is also provided. This slower rate is more practical if a temporary storage of the encoded PCM information is made on a commercial analog tape - the slower rate of information transmission requires a narrower bandwidth in the tape recorder. The recorded PCM information can be played back into the decoder unit at a later time.

The following discussion is an explanation of the method used to generate the signal and clock channels. The section on the decoder explains how the original analog signals are reconstructed.

The data formatter is depicted in Figure 7. It consists of three primary functional units: search counter, data registers, and programmer.

The search counter scans sequentially the six signal-selection outputs (Figure 4) to determine if any input signal has met the selection criteria. It stops on a selected input and enables a second analog-to-digital conversion to be made from the analog input gated to the analog-to-digital con-

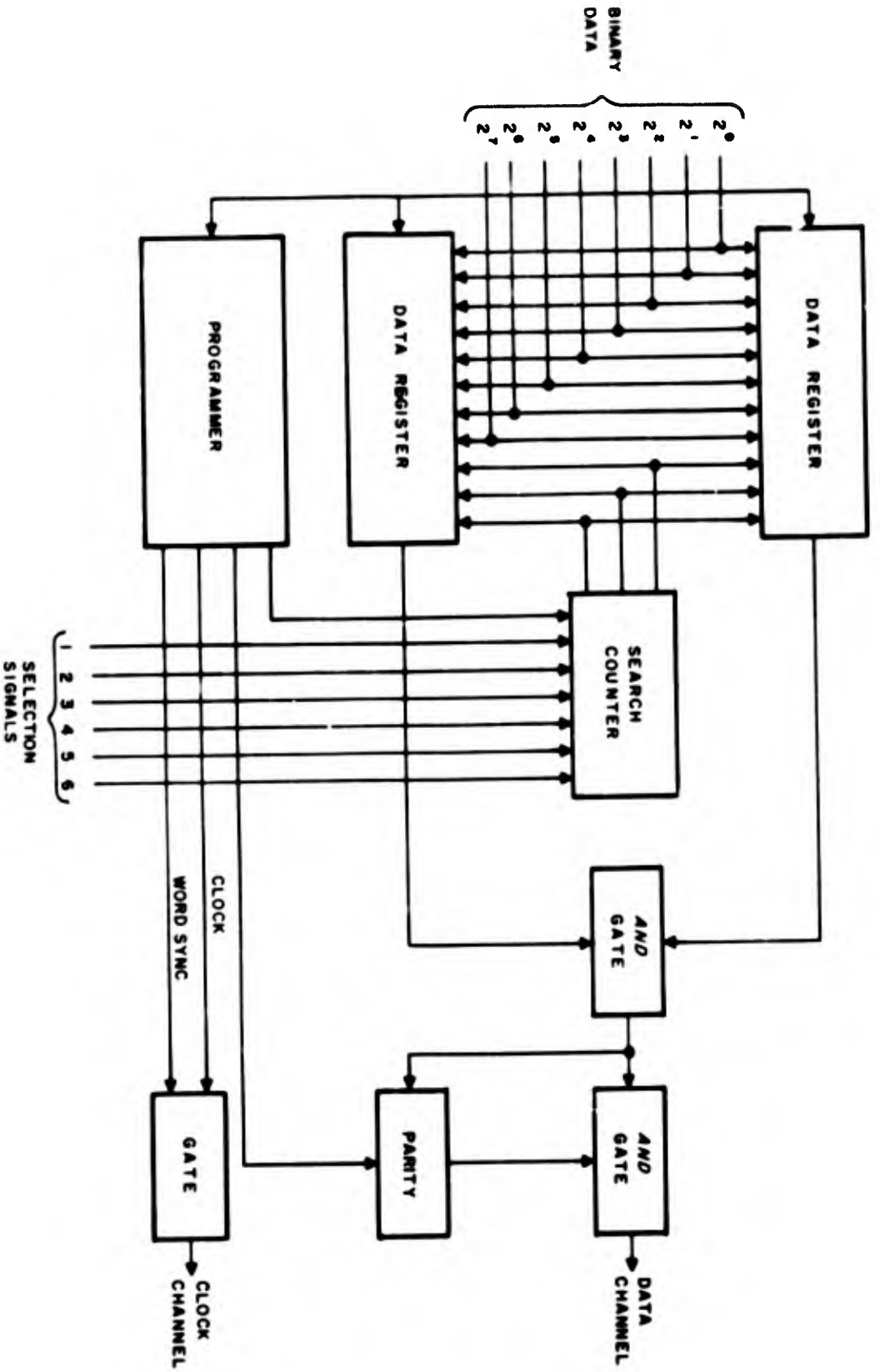

FIGURE 7. ENCODER DATA FORMATTER

verter through the unity gain multiplexer. The results of this conversion are set into one of the two data registers.

Because two analog multiplexers exist (one with adjustable gain for the level-selection process and one with unity gain for the telemetered signal), it is possible to telemeter a signal other than the one used to determine signal selection. For example, use can be made of this feature with the Rate Analog Processor developed during Phase III of the work statement. This processor has two outputs: a linear rate and a log rate. If this processor is used to determine heart rate over a range of 30 to 180 bpm, the higher heart rates will probably be characterized by greater absolute fluctuations than the lower rates. It is desirable, therefore, to de-emphasize the effect of fluctuations at the higher heart rates to avoid excessive signal selection at these rates. The log rate output adequately accomplishes this. The log rate analog can then be used to determine signal selection while the linear rate analog is transmitted.

Two data registers temporarily store the data words before transmission. The registers are alternately read out. While one is being read out, the other is updated. Eight data bits and 3 address bits are stored in each register. The 12th bit (parity) is not stored in the register; it is added to the data word after all 11 bits in either register have been read out. Figure 3 depicts the format of the 12-bit words. The 8 data bits are obtained from the analog-to-digital converter after the second analog-to-digital conversion. The 3 address bits are obtained from the search counter.

A third data register stores time code words. This register is updated once every word interval. A word interval is the time required to transmit one 12-bit word. The contents of the register are read out only when the encoder begins telemetering information to the decoder. At that time, two all-zero words are telemetered followed by two time words. The time words have the same format as the other data words. At the end of the fourth word, the data readout is switched to the other two data registers.

The programmer provides the basic timing for the formatter. It is a counter with a basic count of twelve, which is the total number of bits in a data word. When the programmer is initially turned on, it inhibits all data outputs for two word intervals, then allows two time code words to be read out. It then switches the readout to the other data registers.

The programmer is clocked in the high speed (2400 cps) by the system clock, which is also the clock used by the analog multiplexers. In the low speed (400 cps), it receives a clock pulse once every complete cycle of the analog multiplexers.

V. DECODER

The decoder consists of four basic parts: signal detectors and input register, digital-to-analog converter, sample-and hold gates, and programmer. Figure 8 is a block diagram of the decoder.

Signals received on the data and clock channels are filtered and reshaped. Signal detection uses the normal filtering and delayed sampling technique to maximize signal-to-noise ratio at the instant a decision on signal presence is made. The signal is passed through a low-pass RC filter and sampling is delayed for 1-bit interval. The 3-db bandwidth of the filters is switched to accommodate the 2400 or 400 cps rates of transmission.

The detected PCM information is serially shifted into an 11-stage input register (the parity bit is not stored). The parity of each word is checked serially as it is read into the input register.

Eight bits of the data word, corresponding to the binary representation of the original analog voltage are shifted in parallel from the input register to the digital-to-analog converter. The digital-to-analog converter output voltage is the input to six sample and hold gates. To relate the analog voltage to the proper sample and hold gate, the 3-input identification bits are shifted in parallel into signal-identification circuits. The outputs of the identification circuits provide a sample command to the appropriate sample-and-hold gate based on the 3-bit binary identification number.

All timing for the decoder is controlled from the system programmer, which counts out a 12-bit word and then recycles. It is clocked from a free-running oscillator that has a slightly slower frequency than the encoder clock. Information received on the clock channel provides: (1) a bit synch that synchronizes the decoder and encoder oscillators, and (2) a word synch that synchronizes the decoder and encoder programmers.

Analog data are transferred from the digital-to-analog converter output to the sample-and-hold outputs while the 11 bits of the next data word are being read into the input register. The digital-to-analog converter is updated during the time interval that the parity bit is being received by the decoder. The synch is being received on the clock channel at this time.

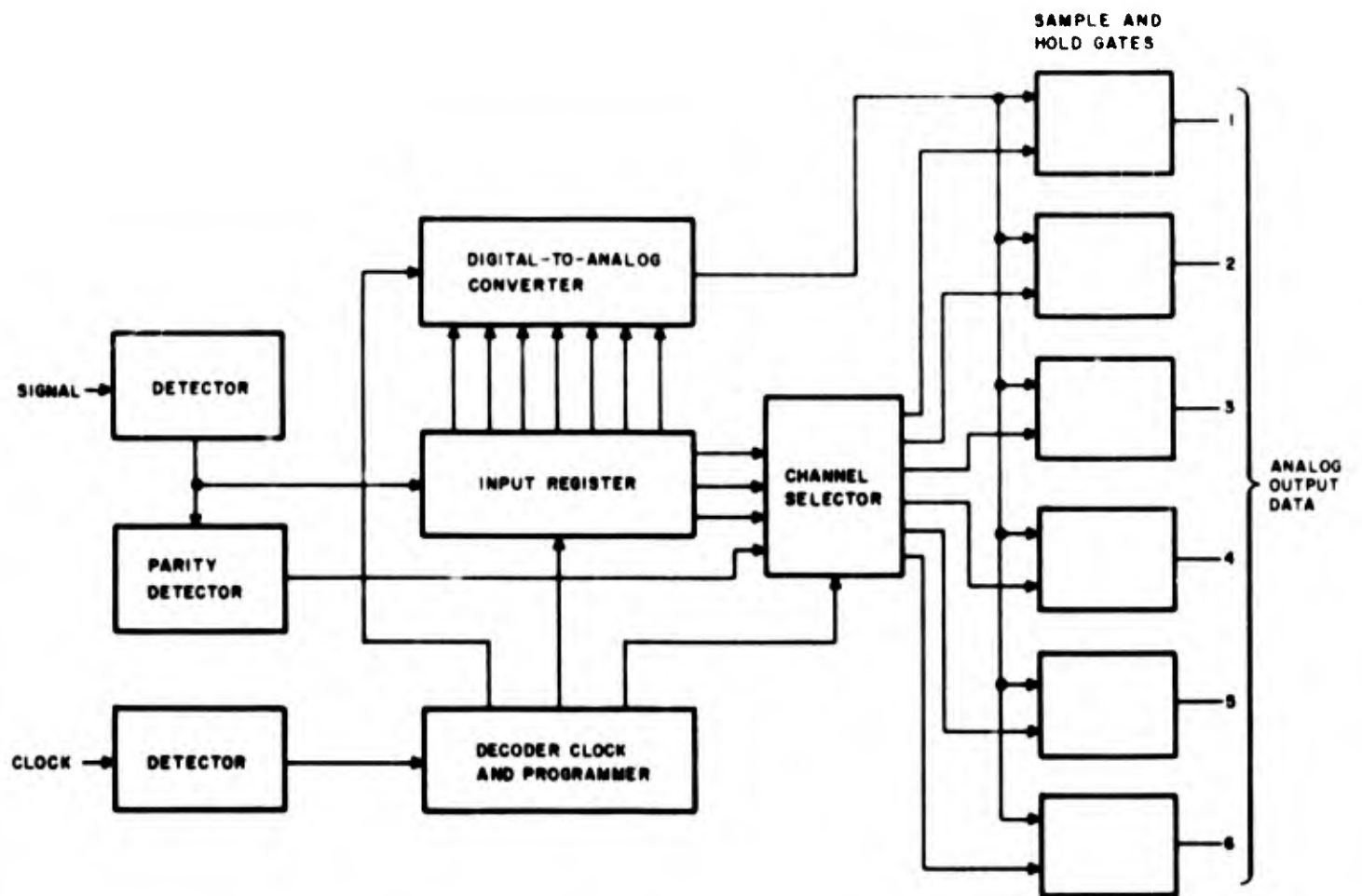

FIGURE 8. DECODER

VI. RATE ANALOG PROCESSOR

The rate analog processor was developed on the basis of the conclusions reached in the Phase II study of various rate-processing techniques. The resulting processor is a miniature analog computer that first produces a voltage proportional to the period (T) of a repetitive signal, and then solves the equation $f = 1/T$ to obtain an output voltage proportional to the frequency of the signal. Figure 9 is a block diagram of the processor.

The analog output voltage is updated with each succeeding crossing of a predetermined threshold. The output, therefore, describes a step function. The voltage at any step represents the apparent frequency of the source based on the interval between the two immediately preceding threshold crossings. In an ECG signal, this distance would be the time interval between two adjacent R waves. Figure 10 describes a typical output signal.

The processor consists of five basic units: (1) a signal amplifier, (2) a period analog generator, (3) an $f = 1/T$ computer, (4) an output buffer, and (5) a logarithmic amplifier.

The processor accommodates four types of input signals: (1) low-level (1 millivolt) differential, (2) low-level single-ended, (3) output of a photocell pickup (also a part of the system), and (4) a high-level input (range 0 to 2 volts DC).

All low-level signals are amplified by the signal amplifier and fed to the period analog generator. A high-level signal is connected directly to the period analog generator.

The signal amplifier has a 3-db pass band between 8 and 30 cps. The output level at 60 cps is 1/200 of the maximum gain of 2000 at 15 cps. A twin-T filter is used to obtain a notch on the frequency response at 60 cps.

A period analog voltage is obtained by sampling and holding the output of a linear ramp generator at the time of each signal threshold crossing. The ramp is discharged and restarted following the sampling of the ramp voltage.

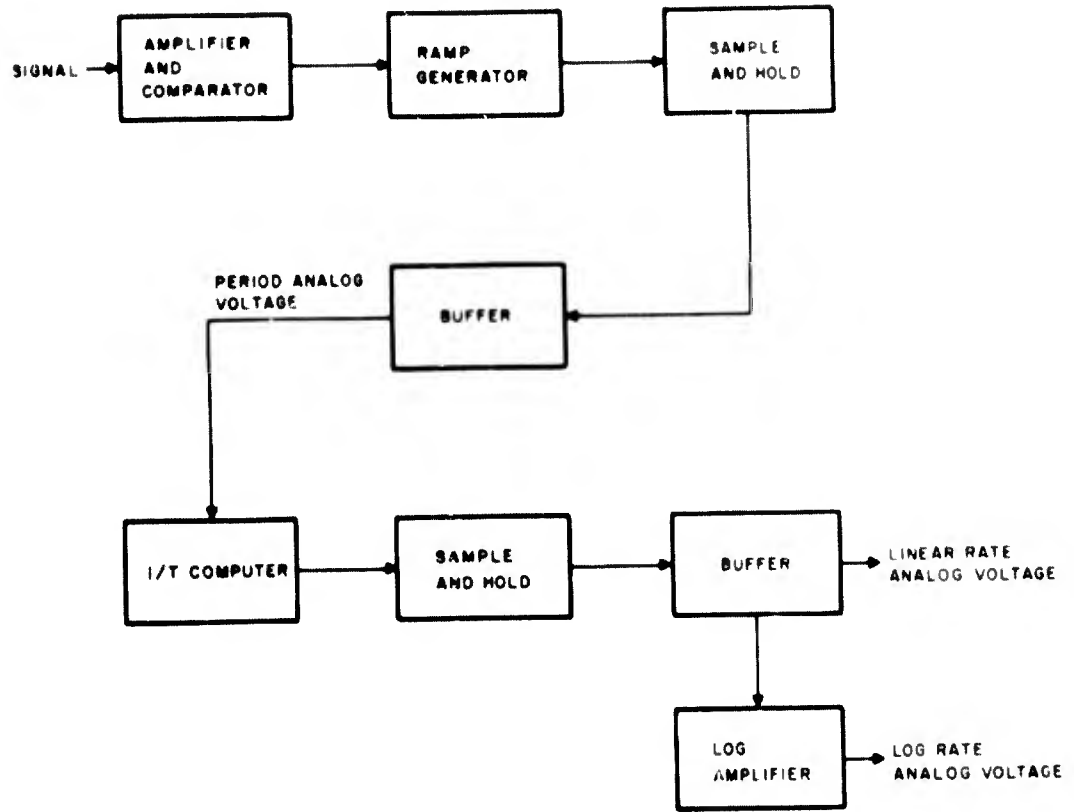

FIGURE 9. RATE ANALOG PROCESSOR

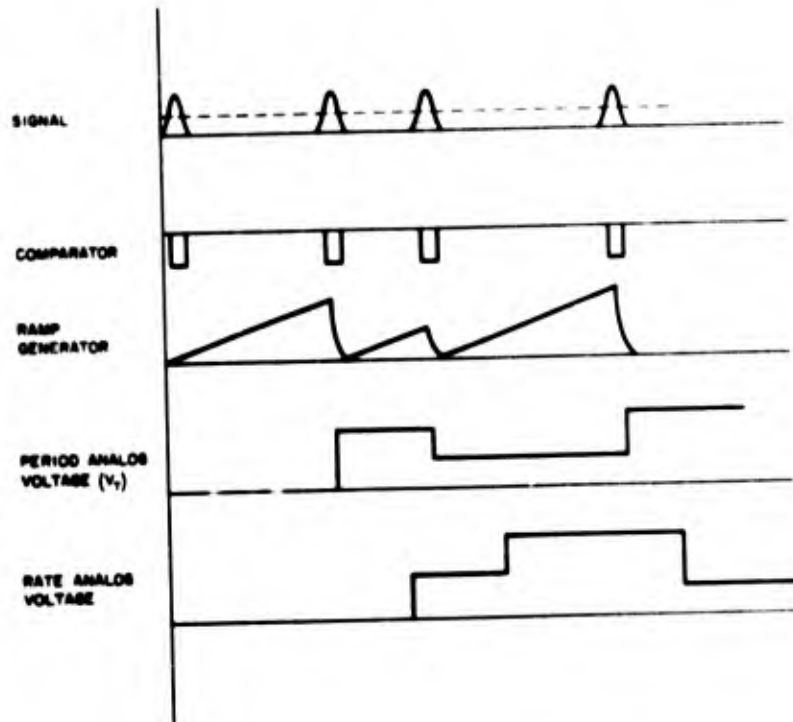

FIGURE 10. RATE ANALOG PROCESSOR TIMING

The period analog voltage is the input to an $f = 1/T$ computing element. The output of this element is then a linear rate analog, which is sampled and held until the next threshold crossing by the input signal. Timing for the operation is shown in Figure 10.

A logarithmic amplifier is connected to the linear rate buffer output. Its characteristic is obtained by a linear amplification of the logarithmic portion of the response curve of two series-connected diodes (Figure 11).

Figures 12 and 13 show the method used to compute the reciprocal period. This method makes use of the relationship in time between the voltages from two RC charging networks having the same time constant. These voltages, assuming 0 volt as an initial voltage, can be described by the following equations.

$$e_1 = V_1 (1 - e^{-t/\tau}) \quad (1)$$

$$e_2 = V_2 (1 - e^{-t/\tau}) \quad (2)$$

If equation 1 is divided by equation 2, the result is

$$\frac{e_2}{e_1} = \frac{V_2}{V_1}$$

If the period analog voltage is used as the charging voltage V_1 , then its reciprocal is given by

$$e_2 = \frac{V_2}{e_1} \times \frac{1}{V_1}$$

V_2/e_1 is a constant multiplying factor determined by V_2 , the second charging voltage, and $e_1(t_0)$, where t_0 is the time at which the voltage e_2 is sampled.

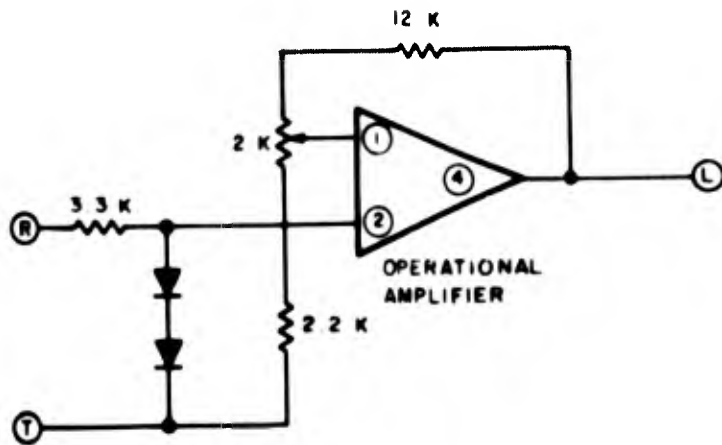

FIGURE 11. LOGARITHMIC AMPLIFIER

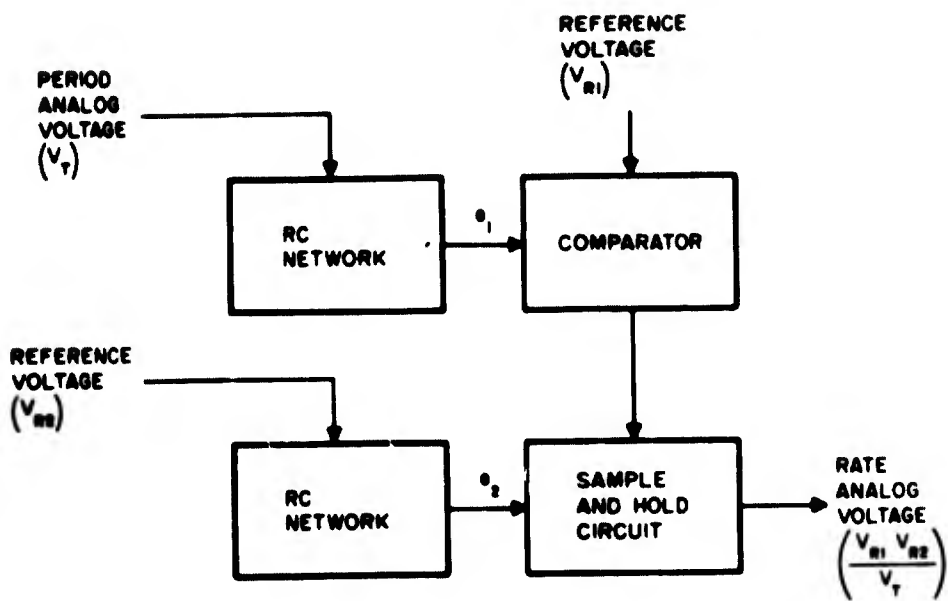

FIGURE 12. BLOCK DIAGRAM OF 1/T COMPUTER

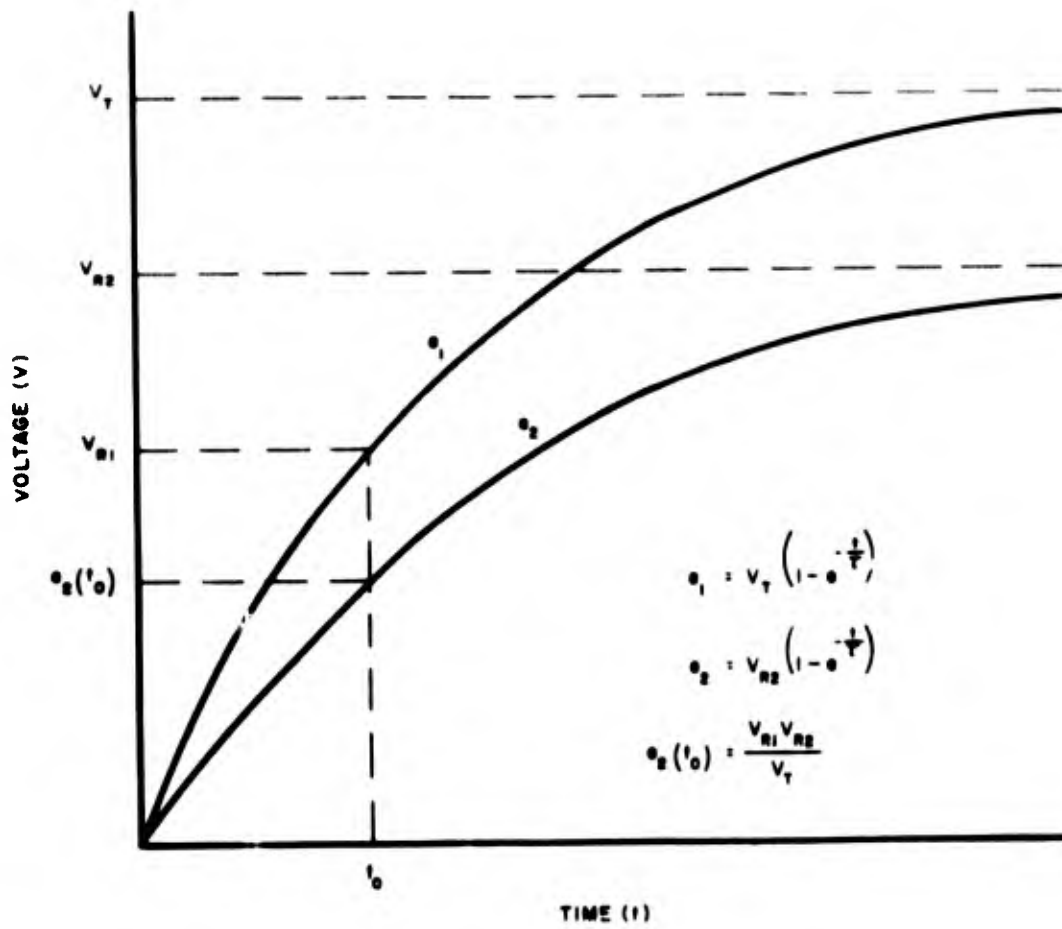

FIGURE 13. OPERATION OF 1/T COMPUTER

VII. MONITORING OF RATE ANALOG OUTPUT

The selective monitoring system can be used to monitor the rate and log rate outputs of the rate analog processor.

Laboratory testing has shown that best results are obtained when the log rate output is used to determine level-change selection. Either the log rate output or the linear rate output can be subsequently telemetered. The separation of selection and information inputs described previously makes it possible to use log rate for selection and linear rate for telemetering. This is useful where relative (percent of ambient) change is a basis for selection but a linear reproduction of the variable is desirable for transmission.

For the purposes of level-change selection, sources monitored by the selective monitoring system have been assumed to be band limited to 1 cps. A filter is thus inserted between the rate analog output and the selective monitoring system. In an actual system, it is impossible to obtain a band-limited signal, since any filtering technique does not completely eliminate higher frequencies. This situation exists with the rate analog processor output.

Successful operation (selection) has been easily obtained at frequencies exceeding 1 cps because of the adjustable delay-on-dropout feature in the level-change selection circuitry. Continuous selection of signals with frequencies of 100 cps is reliably obtained.

VIII. PERFORMANCE REQUIREMENTS OF OPERATIONAL SYSTEM

An operational system differs from the laboratory demonstration system in areas such as controls and modes of operation. Governing the design of such a system would be the need to minimize the amount of components in the airborne monitoring system and the possible need for a remote command capability.

The major differences between the laboratory system and an operational system are summarized below:

1. A ground-to-air command communication channel would supply the commands initiated in the laboratory demonstration model by the CHANNEL SELECTION switches. These switches would be located on an operator's console at the ground-based decoder. The selection criteria would be permanently designed into the airborne equipment.
2. Level selection sensitivities, limit-detection thresholds, and channel drop-out delays would be preset into the airborne monitoring equipment and would then be fixed.
3. A simpler self-check routine than the one used in the laboratory system would be needed. The self-check routine of the laboratory system checks all active channels in any mode of operation. It is probably too elaborate for an operational system. It may be advantageous to substitute a programmed selection of all channels for a self-check routine.

COMMAND SYSTEM

The command link would provide a means for ground operator control for some, or all, of the transmission channels. This function is performed in the laboratory system by the CHANNEL SELECTION switches mounted on the encoder.

The command link consists of a ground-based encoder and an airborne decoder. Command signals are multiplexed by the encoder; its output is a single PCM channel.

The encoder transmits serial binary command information to the airborne decoder, which demultiplexes and identifies the commands, and directs them to the proper control circuits.

Selective monitoring techniques are also applicable in the command system. A data formatter similar to the one used in the laboratory demonstration model can be used to multiplex a number of digital command inputs. This method of multiplexing, by virtue of a search counter that stops only on selected inputs, eliminates the channel space wasted by a system that multiplexes all inputs periodically. As in the demonstration telemetry system, each input would require its own coded identification number.

TELEMETRY SYSTEM

Design of a practical telemetry system proceeds in the following steps:

1. A list is compiled of all signal sources and their characteristics. The list should include information on the frequency content of the signals and the accuracy requirements for signal reproduction.
2. Sampling rates are determined for each input, which will satisfy the accuracy requirements.
3. An overall clock frequency for multiplexing all channels is determined. This frequency is equal to the average number of samples per second per channel times the number of channels. If all channels are sampled at the same rate, this product becomes the sampling frequency times the number of channels. An equivalent definition of the clock frequency is: "the clock frequency equals the sum of the sampling rates of all channels."
4. A transmission rate is determined based on the multiplexing rate and the binary representation of the signal. In general, this rate will be equal to the product of the multiplexing rate and number of bits used in the binary representation.

When selective monitoring is used in the system, steps 3 and 4 are modified in the manner outlined below. The desired result of selective monitoring is that a lower

multiplexing frequency can be used, which results in an acceptable loss of data.

Before proceeding with the discussion of steps 3 and 4, it is important to note the differences between standard time division multiplexing and the multiplexing scheme used in a selective monitoring system. The standard data-acquisition system monitors all inputs at all times. Sampling rates for different inputs can be chosen in such combinations that will use all time divisions in the multiplexed PCM channel.

For example, consider three inputs--A, B, and C. These can be multiplexed in the sequence ABCABC. If this is done, the multiplexing frequency must be high enough to accommodate the input requiring the highest sampling frequency. A reduction in multiplexing frequency can be obtained by a slight rearrangement of the multiplexing. If A requires the highest sampling frequency, the multiplexing sequence might be ABACABAC. The reduction in multiplexing frequency thus accomplished is 33 percent, as can be seen by fixing a sampling frequency for A.

Selective monitoring goes one step further. It attempts to eliminate transmission of an input signal altogether if that signal is not at the moment significant. It then uses the time normally allotted to that signal in the multiplexing sequence to multiplex other inputs. Over a long period of time, a signal will be significant a certain percentage of the total time. Thus, on the average, the multiplexer need not be capable of handling all inputs simultaneously. It is this point upon which the reduction in multiplexing frequency is accomplished.

Should the situation arise that all inputs are simultaneously selected, some information must be destroyed or temporarily stored. It is then necessary to assign a system of priorities to the inputs.

For the purposes of demonstration, the laboratory model monitoring system was designed to lower the effective sampling frequency of an input rather than eliminate it as more inputs became selected. However, these lower sampling frequencies are still adequate to handle 1-cps band-limited information.

The amount of reduction possible in the multiplexing frequency will depend on the percentage of time the signal sources possess the characteristics of interest. These percentages can correctly be called the signal a priori proba-

bilities because (from the point of view of the selective monitoring), the signals are not present unless they possess these predetermined characteristics.

When the sampling frequencies and a priori probabilities have been established, the maximum, though not necessarily realizable reduction, possible in the clock frequency can be calculated from:

$$f_{cs} = \sum_{i=1}^n P_i f_i$$

where

- f_{cs} = clock frequency with selective monitoring,
- f_i = sampling frequency required by the "ith" input signal,
- P_i = a priori probability of the "ith" input signal.

The product $P_i f_i$ then represents the "average" sampling rate associated with the "ith" input over a long period of time.

As an example, consider a system with three input signals having the following specifications:

Sampling rates

- signal number 1 = f_1 = 100 cps
- signal number 2 = f_2 = 50 cps
- signal number 3 = f_3 = 150 cps

Signal a priori probabilities

- signal number 1, P_1 = 0.5
- signal number 2, P_2 = 0.3
- signal number 3, P_3 = 0.4

The minimum clock frequency without selective monitoring, f_{cc} , is the sum of the individual sampling rates.

$$f_{cc} = f_1 + f_2 + f_3 = 100 + 50 + 150 = 300 \text{ cps}$$

The maximum clock frequency is three times the highest sampling rate or

$$3 \times 150 = 450 \text{ cps}$$

In a periodic multiplexing system, it is possible to interlace the different multiplexed signal samples according to the sequence 12131213. To obtain this sequence, the sampling frequencies must be changed to

$$f_1 = 100 \text{ cps}$$

$$f_2 = 100 \text{ cps}$$

$$f_3 = 200 \text{ cps}$$

(The sampling frequency for any channel cannot be lowered.) The overall multiplexing clock frequency is then the sum of these sampling frequencies, or

$$f_{cc} = 100 + 100 + 200 = 400 \text{ cps}$$

This is not much improvement over the maximum clock frequency at 450 cps.

The clock frequency required with selective monitoring, however, is

$$\begin{aligned} f_{cs} &= 0.5 \times 100 \text{ cps} + 0.3 \times 50 + 0.4 \times 150 \\ &= 50 + 15 + 60 = 125 \text{ cps} \end{aligned}$$

Of course, such a low frequency is impossible since one of the channels requires a 150-cps sampling rate. One would choose a frequency such as 200 cps, which would be capable of handling the 150-cps signal and another signal. The clock rate has thus been reduced from 300 to 200 cps.

The transmission frequency in an ordinary system is the product of the multiplexing clock frequency and the number of binary bits used to represent each sample. In determining the transmission frequency of a selective monitoring system, the number of binary bits used to represent a signal sample must include the bits used for input identification.

SYNCHRONIZATION OF ENCODER AND DECODER

The problems of word and bit synchronization between encoder and decoder are a subject of study by themselves. A system must establish synchronization before any attempt is made to decode information. In addition, the system should have maximum protection from noise. Events such as momentary loss of bit or word synch information should result in a relatively low probability of error.

The synchronization of encoder and decoder in the selective monitoring system is accomplished by a clock channel separate from the signal-information channel. The use of a second channel for clock information has an inherent advantage over a single-channel system--it is able to supply bit synchronization information for every bit interval in the signal channel.

A single-channel system must time share its clock information with signal information. As a result, the encoder and decoder units must operate in synchronism for a large percentage of time without clock information. This places strict accuracy and stability requirements on the clock oscillators used in the encoder and decoder. The clock information cannot be sent on the signal channel in frequent intervals without significantly reducing the information-carrying capacity of the channel. In spite of these limitations, this method of synchronization can be (and is) used where these limitations are found acceptable.

A more practical 1-channel system is a 3-level system. In such a system, a binary 1 is a positive signal and a binary 0 is a negative signal. A third neutral level corresponds to no signal. This ternary channel is depicted in Figure 14 with the corresponding binary channel. It can be seen, that the ternary channel has bit-synchronization information built into it.

However, to gain this advantage, a significant amount has been sacrificed. The ternary channel results in a higher bit error rate than the corresponding binary channel since 3 levels (not 2) must be distinguished. In addition, the ternary channel must use a transmission bandwidth twice that of the binary channel in order to send the equivalent amount of information.

The names normally given to the binary and ternary channels described are non-return-to-zero (NRZ) and return-to-zero (RZ), respectively. The latter can also be used in describing a binary channel that has a dead space between adjacent bits.

Phase stability between encoder and decoder oscillators in the selective monitoring system depends on a telemetry clock channel that operates at the same frequency as the signal channel. These two channels must be transmitted over the same RF carrier. Since their frequencies are identical, separation of the channels must come by phase shifting one of the channels 90 degrees with respect to the other. These in-phase and quadrature channels can then be added together and the resultant output used to modulate the RF carrier. The channels are separated in the decoder by the reverse process.

A limitation of this method is crosstalk between the in-phase and quadrature channels, which occurs when the channel phase difference drifts from 90 degrees. However, this method of synchronization is still superior to the 1-channel approach described previously. The 1-channel method is subject to phase drift and, what is even worse, frequency drift. The 2-channel approach ensures phase coherence between encoder and decoder oscillators.

An alternative method is now described, which should be noted because of its ability to establish phase coherence even under adverse noise conditions.

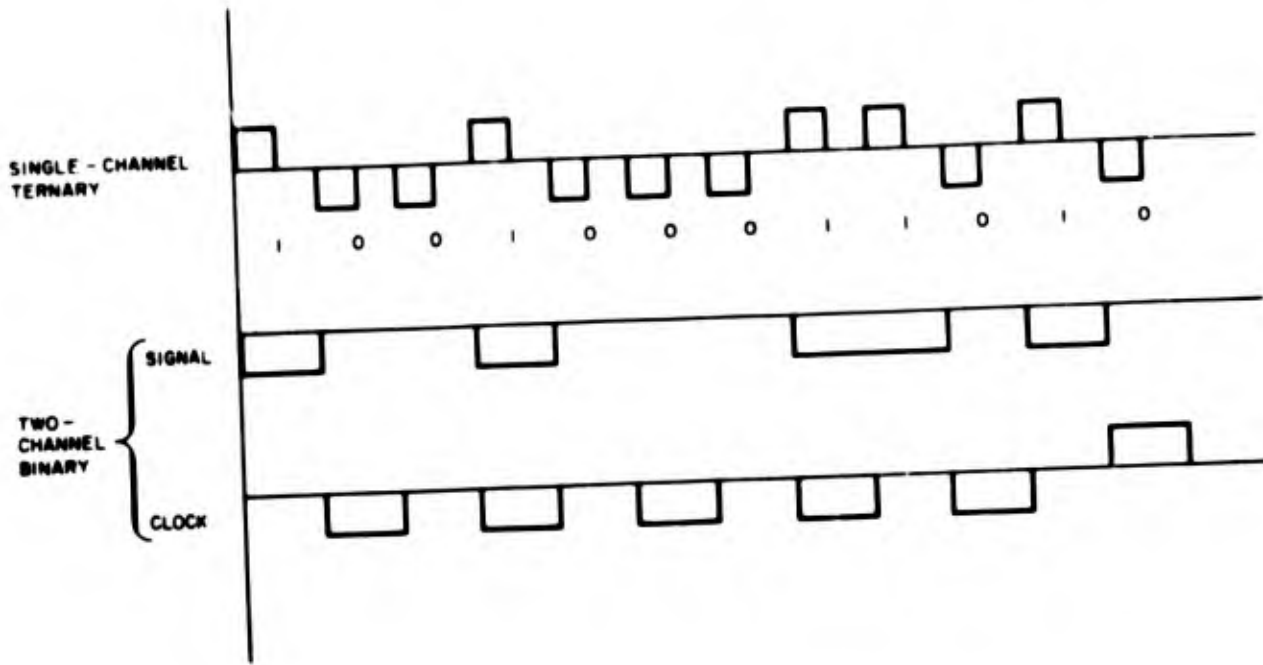

FIGURE 14. 2-CHANNEL AND 1-CHANNEL DATA WORDS

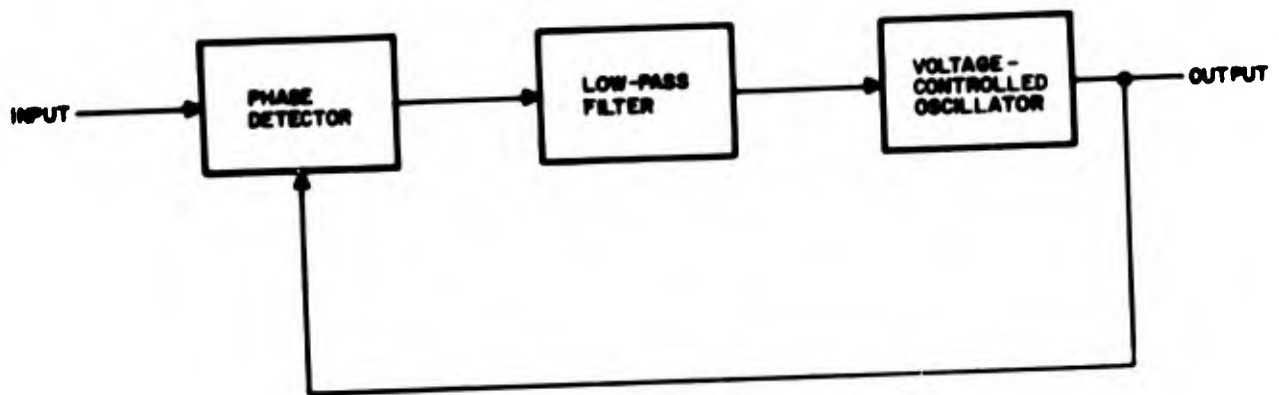

FIGURE 15. PHASE-LOCKED LOOP DETECTOR

A technique for bit synchronization with signal-to-noise ratios significantly less than 0 db has been developed. This technique establishes phase stability in the encoder and decoder without the use of the clock-information channels described previously.

The approach is briefly described below. Essentially, it establishes phase coherence between an oscillator in the transmitter and a voltage-controlled oscillator in the receiver.

All clock frequencies in the transmitter and receiver are then obtained by dividing or multiplying the frequencies of these reference oscillators. The essential element in this technique is the phase-locked loop (Figure 15), which establishes phase coherence between the two oscillators. Its operation is described below.

A phase detector compares the relative phases of the two oscillators. Its output is fed through a very narrow band filter and used to control the voltage-controlled oscillator (VCO). A difference in phase between the two oscillators produces an output in the phase detector, which tends to change the VCO frequency such that a constant phase relationship is established. This device, by virtue of its narrow-band filter, can operate with signal-to-noise ratios significantly less than 0 db. For this reason, this method is superior.

BLANK PAGE

IX. MICROMINIATURIZED CIRCUITS

Two microminiaturization techniques were explored: thin-film integrated circuitry and semiconductor networks. These techniques are the only ones that have advanced to the point where they can seriously be considered. Of these, the only one currently feasible is the semiconductor network.

THIN-FILM INTEGRATED CIRCUITRY

Thin-film processes begin with a wafer of non-conducting material, such as ceramic, upon which passive circuit elements are formed by printing or evaporation of metals. This process has been successful in producing passive elements; however, the formation of active components (transistors and diodes) has not progressed past the research stage.

Therefore, active semiconductor components are generally physically attached to the supporting wafer in a thin-film circuit. Interconnections are then made by the same process used for the formation of passive components. The processed circuit is coated for protection.

SEMICONDUCTOR INTEGRATED CIRCUITRY

Semiconductor integrated circuits are completely fabricated within a single piece of silicon material. In other words, all components, both active and passive, with the necessary interconnections for a network, such as a flip-flop, are constructed on a single crystal of semiconductor material.

The technology of the semiconductor integrated circuits has advanced well into the stage of large volume production. Product lines in digital circuits have been established by a number of semiconductor manufacturers. Analog circuits are generally available on special order.

From the purely practical standpoint of availability, the semiconductor networks are definitely superior to the thin-film circuits. The semiconductor networks are in volume production, whereas the thin-film circuits have not yet been introduced commercially on a volume basis.

Significant reductions in size can be made in the digital circuitry of the selective monitoring system with the

use of integrated circuits. In determining the physical characteristics of a microminiaturized system, it is necessary to count the total number of nodes (functional units such as AND gates, OR gates, and flip-flops) in the system. In making a comparison between the sizes of the breadboard selective monitoring system and its microminiaturized version, it is further necessary to account for the differences required in the logic design because of the fan-in, fan-out characteristics of the modules.

Currently, specialized analog circuits such as operational amplifiers are not as readily available in the integrated circuit packages as the digital circuits. However, any reasonable analog circuit can be fabricated in micro-miniature packages from design specifications. Thin-film techniques seem better adapted to the fabrication of special circuits than the semiconductor networks. The reasoning here is that the set-up cost for a special module is significantly less for a thin-film circuit. Semiconductor networks become less expensive only on mass-produced modules.

In spite of the superior packaging attainable in analog circuits using integrated circuits, present high-density packaging techniques with low-power design of circuits using conventional components should not be overlooked.

CHARACTERISTICS OF MICROMINIATURIZED SELECTIVE MONITORING SYSTEM

The following mechanical components in the system can be eliminated or reduced in size: (1) the check cycle and program selection timer, (2) the check cycle interval timer, and (3) the input switching relays that switch the input between the check signal and the monitored signal. All control switches could be eliminated. Time delay relays occupying 1 cubic inch of space can replace the two mechanical timers. The input switching relays can be replaced by crystal can relays occupying 1/4 cubic inch of space.

Digital modules can be replaced by the semiconductor integrated circuits. Table I shows the approximate module count for encoder and decoder units. Analog circuits comprise 15 percent of the total circuits in the laboratory demonstration system and could be condensed with high-density packaging. In general, however, components such as large timing capacitors used in the delay-on-dropout circuits and precision resistors used in the analog-to-digital converter would prevent the extreme reduction in size obtainable with the digital circuits.

TABLE I
DIGITAL MODULE COUNT

<u>Functional Unit</u>	<u>Modules/Bit</u>	<u>Total Modules</u>
DATA FORMATTER		
Shift register - 11 stage	3	33
Counter - 8 stage	2	16
Counter - 4 stage	2	8
Logic - 150 nodes	1	<u>150</u>
		207

Power = 40 mw per module × 207 modules = 8 watts

SELECTION CIRCUITS		
Shift register (5) - 6 stage	3	5 × 18 = 90
Bit memory (18) -	1	18
Logic - 75 nodes	1	<u>75</u>
		183

Power = 40 mw per module × 183 modules = 7.3 watts

DECODER		
Shift register - 11 stage	3	33
Counter - 4 stage	2	8
Logic 55 nodes	1	<u>55</u>
		96

Power = 40 mw per module × 86 modules = 3.3 watts

- - -

A 6-inch square printed-circuit board accommodates 100 elements packaged in TO-5 cases. This may not be possible in general because of interconnections. Assuming one half of this density, the encoder digital circuitry can be accommodated on eight 6-inch square printed-circuit boards; the decoder digital circuitry would require two boards.

BLANK PAGE

X. PERFORMANCE TESTING OF SELECTIVE MONITORING SYSTEM

Figure 16 contains chart recordings of the decoder output with the encoder in various modes of operation. The input signals were obtained from a Hewlett-Packard Model 202A low-frequency function generator.

In Figure 16A, the recording starts with the encoder in the LIMIT SELECTION mode. The limit thresholds are set at 1.5 and 3.5 volts DC. The signal excursion is between 0.5 and 4.5 volts DC; signal frequency is 0.5 cps. The input to the encoder is the bottom trace and the output of the decoder is the top trace.

At point A, the signal is selected as it crosses the 3.5-volts DC threshold. As the signal falls below the threshold, it is rejected, and the sample and hold output gates of the decoder hold the output voltage at 3.5-volts DC. At point B, the signal crosses the lower threshold (1.5-volts DC) and is again selected.

At point C, the system is switched by the mechanical timer to the self-check mode. An exponential signal is now applied to the encoder input. The exponential signal is rejected in the 1.5 to 3.5 volts DC range as was the triangular signal. The system goes into a program-selection mode immediately following the self-check cycle. Thus, between D and E, the signal is selected continuously. The normal limit selection cycle begins again at point E.

At point F, the encoder is switched into the LEVEL CHANGE SELECTION mode. The delay-on-dropout time of the level-change selection circuit is set at 3 seconds.

Since the signal frequency is 0.5 cps, selection is continuous. At point G, the signal frequency is changed to 5 cps, and again selection is continuous.

In Figure 16B, the encoder is placed in the LEVEL SELECTION mode. A triangular signal is applied to the input of the encoder. It has a frequency of 0.015 cps and voltage limits of 0.5 and 4.5 volts DC. The delay-on-dropout of the level-selection circuit is set at 1.5 seconds. The upper trace is the output of the decoder; the lower trace is the sample and hold command output for analog output number one.

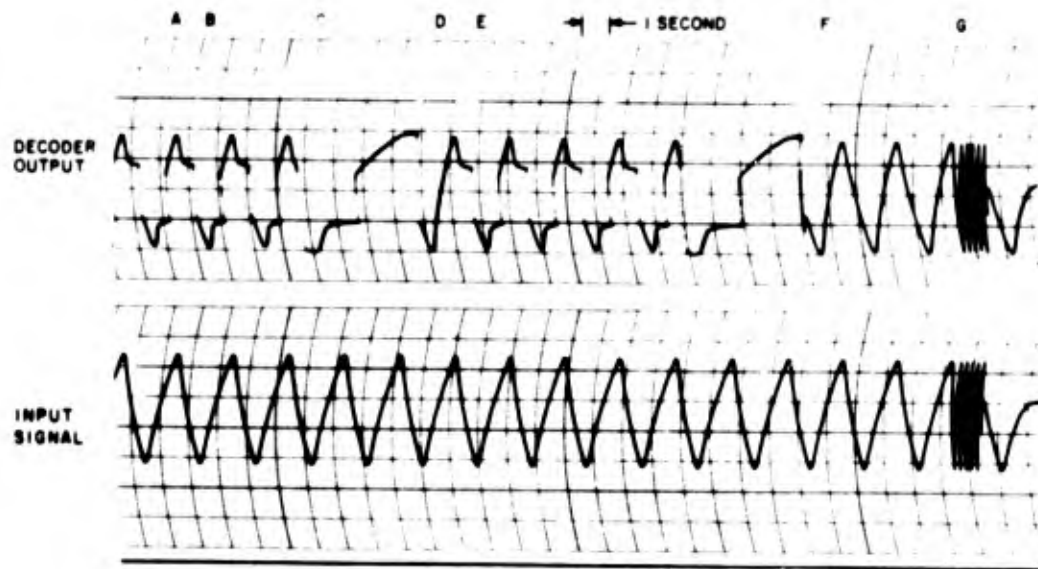

A LIMIT SELECTION, SELF-CHECK CYCLE, PROGRAMMED SELECTION AND CONTINUOUS LEVEL CHANGE SELECTION

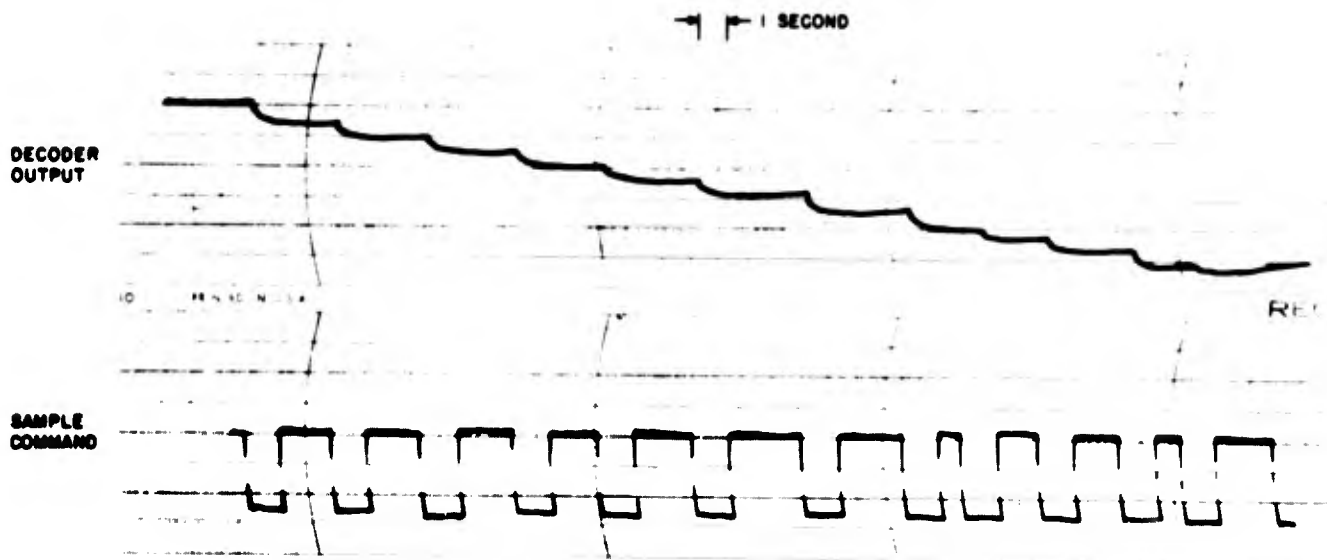

B SIGNAL DROPOUT IN LEVEL-CHANGE SELECTION MODE

FIGURE 16. SYSTEM OUTPUTS

Signal selection occurs when this output is -10 volts DC.
A signal dropout has occurred when this output is 0 volt DC.

It can be seen that the triangular wave is followed during periods of selection. During periods of rejection, the sample and hold output gates hold the output voltage constant. The signal is not changing fast enough to produce continuous selection. Thus, the encoder selects the signal only for the 1.5-second delay-on-dropout period.

Figure 17 is a graph of the rate analog processor frequency response. The processor has been calibrated to accommodate heart rates from 30 to 180 beats per minute.

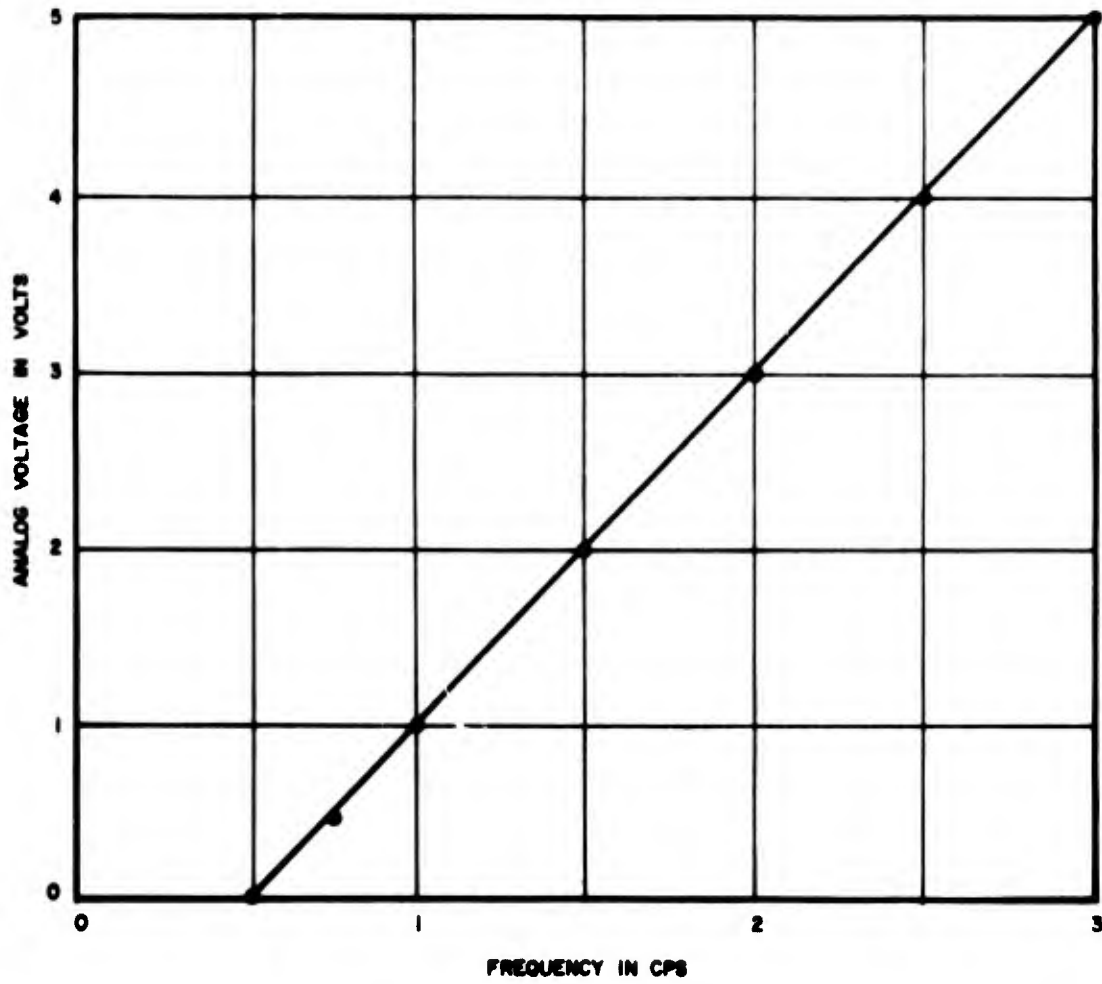

FIGURE 17. RATE ANALOG PROCESSOR FREQUENCY RESPONSE

XI. SUMMARY AND CONCLUSIONS

Selective monitoring as a useful data-reduction technique has been demonstrated by means of a breadboard selective monitoring system. This system can detect level changes or threshold crossings of analog input data and use these criteria in the selection or rejection of the signal for processing.

Encoder and decoder units constructed have simulated the originating and terminal ends of a telemetering channel used to transmit information selected by the level-change or threshold detection circuits. The encoder digitizes the selected analog signal and transmits it to the decoder. Two channels, one for signal and one for clock information are used in the transmission. The decoder reconstructs the original analog input signal. Up to six analog input signals can be monitored by the system. These signals, after digitizing, are time-division multiplexed on the signal-transmission channel.

Time-division multiplexing is done in a manner that leaves no dead space in the transmitted PCM signal channel when one or more input signals have been selected. This method has the advantage of using all transmission time.

A rate analog processor has been constructed, which is suitable for use with ECG signals, a photoelectric pickup, or other low- or high-level periodic signals at low frequencies. This processor is compatible with the selective monitoring system. The output of the rate analog processor describes a step function with discontinuities occurring at each signal threshold detection. With an ECG input, the unit measures the interval between successive R waves.

Because of the limited rate of level-change selection capability in the selective monitoring system, a filter must be inserted between the processor and the system. The determining factor in the level-change selection is the slope of the changing signal, which depends on the bandwidth and amplitude of the monitored signal and not bandwidth alone. For this reason, the system is capable of selecting signals well in excess of the 1-cps assumed frequency band--100-cps signals have been selected and transmitted continuously.

Continuous transmission occurs when the signal is changing fast enough to cause repeated selection of signals before the delay-on-dropout period is exceeded. By appro-

priate adjustment of this dropout interval, continuous transmission can be obtained over a wide range of signal slopes. The maximum obtainable delay period in the system is 10 seconds.

A programmed self-check cycle is incorporated in the system. During this cycle, an RC charging curve is switched to all inputs to test the level change or limit-selection capability of the equipment. It was pointed out that the self-check used in a satellite system might in some instances be replaced by an operator selection command that would be transmitted on a command channel to the encoder. In this way, a signal could be checked at any time by selecting it.

In addition, a command channel for operator selection of signals can be used to advantage because of the nature of the monitoring techniques. A failure in a selection circuit could be overcome by an override command. With this capability, it may not be necessary to check the signal-selection circuits.

The system can be microminiaturized quite readily because of the preponderance of digital circuits that can be converted to integrated circuits. Semiconductor networks are definitely superior to thin films in microminiaturization of digital circuits at the present because of their availability and cost. Analog circuits are not condensed so easily, but high-density packaging of standard components and thin-film techniques seem to be the most promising.

Selective-monitoring techniques are useful wherever signals exhibit predictable characteristics. The criteria used in selection of signals during this study have been level change and threshold crossing, although these criteria do not exhaust all possibilities. They do however, have the most meaning for physiological data because of its low-frequency characteristics.

BLANK PAGE

DOCUMENT CONTROL DATA - R&D

(Security classification of title, body of abstract and indexing annotation must be entered when the overall report is classified)

1. ORIGINATING ACTIVITY (Corporate author) Airborne Instruments Laboratory A Division of Cutler-Hammer, Inc Deer Park, Long Island, New York		2a. REPORT SECURITY CLASSIFICATION UNCLASSIFIED	
		2b. GROUP N/A	
3. REPORT TITLE ADVANCED SELECTIVE MONITORING SYSTEMS			
4. DESCRIPTIVE NOTES (Type of report and inclusive dates) Final report, January 1963 - June 1964			
5. AUTHOR(S) (Last name, first name, initial) Babich, A. Morton, G.			
6. REPORT DATE November 1964		7a. TOTAL NO OF PAGES 50	7b. NO. OF REFS 1
8a. CONTRACT OR GRANT NO. AF 33(657)-10462		8b. ORIGINATOR'S REPORT NUMBER(S)	
a. PROJECT NO 7222			
c. Task No. 722203		8c. OTHER REPORT NO(S) (Any other numbers that may be assigned this report)	
d.		AMRL-TR-64-97	
10. AVAILABILITY/LIMITATION NOTICES Qualified requesters may obtain copies of this report from DDC. Available, for sale to the public, from the Clearinghouse for Federal Scientific and Technical Information, CFSTI (formerly OTS), Sills Bldg, Springfield, Virginia 22151			
11. SUPPLEMENTARY NOTES		12. SPONSORING MILITARY ACTIVITY Aerospace Medical Research Laboratories, Aerospace Medical Division, Air Force Systems Command, Wright-Patterson AFB, Ohio	
13. ABSTRACT In order to reduce the amount of data obtained in multiple-input data acquisition systems--subsequently reducing power and size requirements in space vehicles, or reducing processing time in a computer analysis--a Selective Monitoring System was built and tested. The present system is an extension of a laboratory model which was used as criteria for signal selection signal changes from a steady state and signal excursions beyond predetermined limits. That system (laboratory model) was expanded to include originating (encoding) and terminal (decoding) equipment for a PCM data-transmission channel. The encoding and decoding equipment used the selective-monitoring characteristics of the laboratory model to obtain a data transmission rate lower than that required in an ordinary multiple input data acquisition system. Signals selected by the encoder unit were reconstructed in the decoder unit. A rate analog processor, compatible with the Selective Monitoring System, and suitable for use as a cardiometer, was built and tested. Performance requirements in an operational system are described. The reduction in size and power consumption obtainable with microminiaturization is analyzed.			

UNCLASSIFIED
Security Classification

DOCUMENT CONTROL DATA - R&D		
<i>(Security classification of title, body of abstract and indexing annotation must be entered when the overall report is classified)</i>		
1. ORIGINATING ACTIVITY (Corporate author) Airborne Instruments Laboratory A Division of Cutler-Hammer, Inc Deer Park, Long Island, New York		2a. REPORT SECURITY CLASSIFICATION UNCLASSIFIED
		2b. GROUP N/A
3. REPORT TITLE ADVANCED SELECTIVE MONITORING SYSTEMS		
4. DESCRIPTIVE NOTES (Type of report and inclusive dates) Final report, January 1963 - June 1964		
5. AUTHOR(S) (Last name, first name, initial) Babich, A. Morton, G.		
6. REPORT DATE November 1964	7a. TOTAL NO OF PAGES 50	7b. NO. OF REFS 1
8a. CONTRACT OR GRANT NO. AF 33(657)-10462 b. PROJECT NO 7222 c. Task No. 722203 d.		9a. ORIGINATOR'S REPORT NUMBER(S) 9b. OTHER REPORT NO(S) (Any other numbers that may be assigned this report) AMRL-TR-64-97
10. AVAILABILITY/LIMITATION NOTICES Qualified requesters may obtain copies of this report from DDC. Available, for sale to the public, from the Clearinghouse for Federal Scientific and Technical Information, CFSTI (formerly OTS), Sills Bldg, Springfield, Virginia 22151		
11. SUPPLEMENTARY NOTES	12. SPONSORING MILITARY ACTIVITY Aerospace Medical Research Laboratories, Aerospace Medical Division, Air Force Systems Command, Wright-Patterson AFB, Ohio	
13. ABSTRACT In order to reduce the amount of data obtained in multiple-input data acquisition systems--subsequently reducing power and size requirements in space vehicles, or reducing processing time in a computer analysis--a Selective Monitoring System was built and tested. The present system is an extension of a laboratory model which was used as criteria for signal selection signal changes from a steady state and signal excursions beyond predetermined limits. That system (laboratory model) was expanded to include originating (encoding) and terminal (decoding) equipment for a PCM data-transmission channel. The encoding and decoding equipment used the selective-monitoring characteristics of the laboratory model to obtain a data transmission rate lower than that required in an ordinary multiple input data acquisition system. Signals selected by the encoder unit were reconstructed in the decoder unit. A rate analog processor, compatible with the Selective Monitoring System, and suitable for use as a cardiometer, was built and tested. Performance requirements in an operational system are described. The reduction in size and power consumption obtainable with microminiaturization is analyzed.		

DD FORM 1473
1 JAN 64
AS-WP-6-AUG 64 489

UNCLASSIFIED
Security Classification

BLANK PAGE