

(FINAL REPORT)  
SOLID STATE TACAN

TECHNICAL DOCUMENTARY REPORT NO. ESD-TDR-64-548

SEPTEMBER 1964

ESTI PROCESSED

Thiel J. Gomm  
R. Max Steadman  
Harold C. Renner  
K. Charles Eder

DDC TAB  PROJ OFFICER

ACCESSION MASTER FILE

\_\_\_\_\_

DATE \_\_\_\_\_

ESTI CONTROL NR AL 44214

CY NR 1 OF 1 CYS

**ESD RECORD COPY**

RETURN TO  
SCIENTIFIC & TECHNICAL INFORMATION DIVISION  
(ESTI), BUILDING 1211

COPY NR. \_\_\_\_\_ OF \_\_\_\_\_ COPIES

ENGINEERING DIVISION  
DIRECTORATE OF RADAR AND OPTICS  
DEPUTY FOR ENGINEERING AND TECHNOLOGY  
ELECTRONIC SYSTEMS DIVISION  
AIR FORCE SYSTEMS COMMAND  
UNITED STATES AIR FORCE  
L. G. Hanscom Field, Bedford, Massachusetts

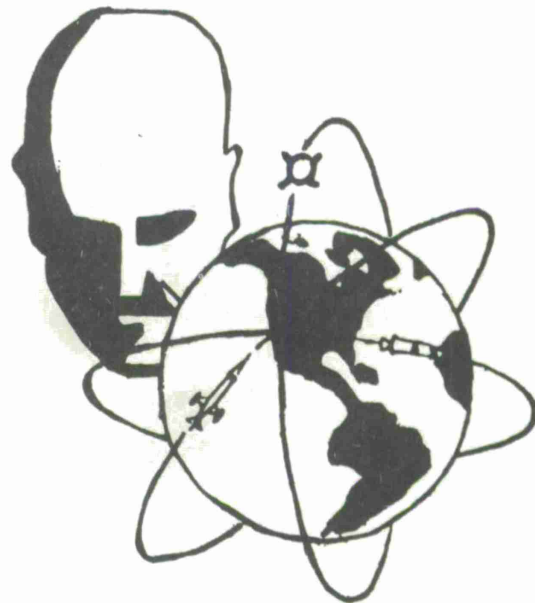

System 482L

AD609810

(Prepared under Contract AF 19 (628)-3263 by the Montek Division,  
Model Engineering & Manufacturing Corp., 4438 South State Street,  
Salt Lake City, Utah 84107.)

When US Government drawings, specifications or other data are used for any purpose other than a definitely related government procurement operation, the government thereby incurs no responsibility nor any obligation whatsoever; and the fact that the government may have formulated, furnished, or in any way supplied the said drawings, specifications, or other data is not to be regarded by implication or otherwise as in any manner licensing the holder or any other person or conveying any rights or permission to manufacture, use, or sell any patented invention that may in any way be related thereto.

Do not return this copy. Retain or destroy.

#### DDC AVAILABILITY NOTICES

Qualified requesters may obtain copies from Defense Documentation Center (DDC). Orders will be expedited if placed through the librarian or other person designated to request documents from DDC.

Copies available at Office of Technical Services, Department of Commerce.

(FINAL REPORT)  
SOLID STATE TACAN

TECHNICAL DOCUMENTARY REPORT NO. ESD-TDR-64-548

SEPTEMBER 1964

Thiel J. Gomm  
R. Max Steadman  
Harold C. Renner  
K. Charles Eder

ENGINEERING DIVISION  
DIRECTORATE OF RADAR AND OPTICS  
DEPUTY FOR ENGINEERING AND TECHNOLOGY  
ELECTRONIC SYSTEMS DIVISION  
AIR FORCE SYSTEMS COMMAND  
UNITED STATES AIR FORCE  
L.G. Hanscom Field, Bedford, Massachusetts

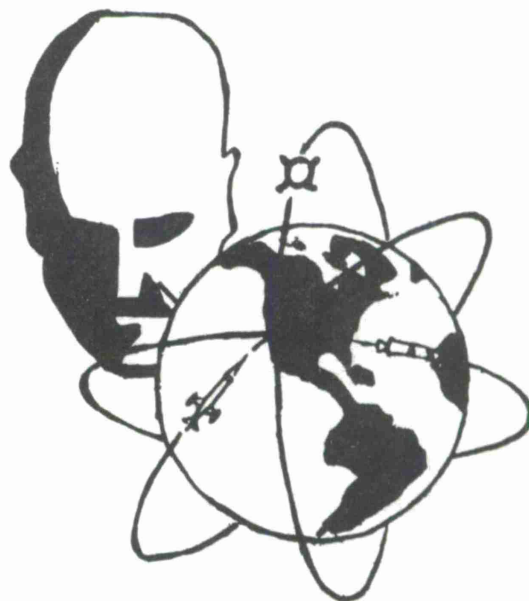

System 482L

(Prepared under Contract AF 19 (628)-3263 by the Montek Division,  
Model Engineering & Manufacturing Corp., 4438 South State Street,  
Salt Lake City, Utah 84107.)

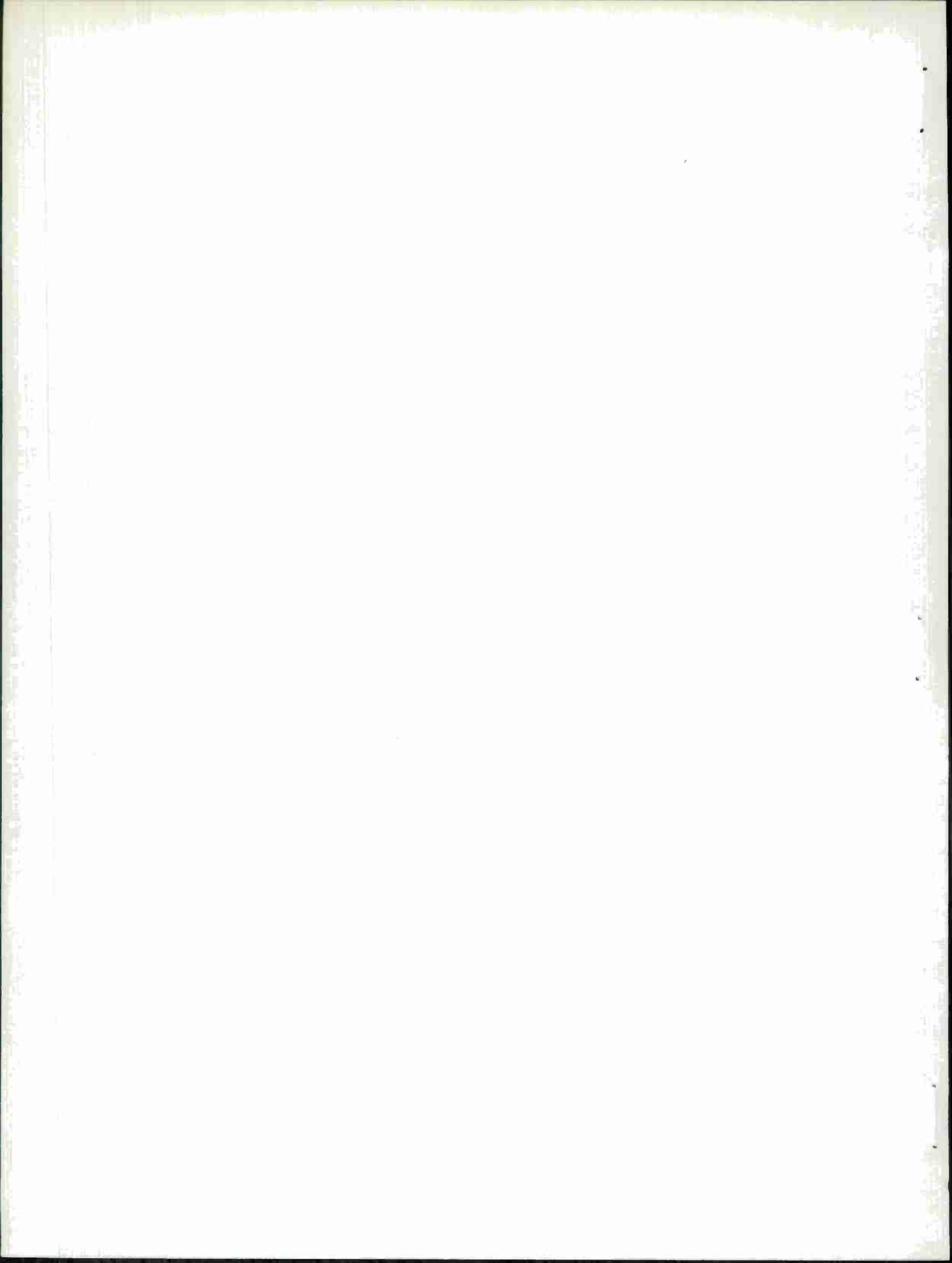



## FOREWORD

This final report, Montek Number 63-234, is written to convey pertinent information concerning, and in compliance with, Contract AF 19(628)-3263, which was awarded to Montek Division of Model Engineering & Manufacturing Corp., on 15 July 1963.

USAF technical monitoring of this contract was accomplished under the cognizance of the 482L Systems Program Office, Electronic System Division, Air Force Systems Command.

Montek's field representatives, Thiel J. Gomm, R. Max Steadman, Harold C. Renner, and K. Charles Eder, made up the four-man team which was assigned the prime responsibility of insuring that the requirements in the above mentioned contract were carried out.

Prior to the award of this engineering service type contract, awards to other contractors had been granted by ESD which provided the USAF with the following experimental breadboard constructed TACAN components:

- (a) Semi solid-state TACAN transmitter;
- (b) Solid-state TACAN receiver-coder;
- (c) Solid-state TACAN identification keyer; and
- (d) Semi solid-state TACAN monitor.

With the use of the above components, the Fort Dawes AN/URN-3 experimental test bed, an AN/ARN-21 airborne set and other auxiliary GFE, the requirements and objectives of the four-man field engineering team were to integrate, test, and evaluate the four experimental solid-state major TACAN components. The preparation and submission of a detailed characteristic, guided by the findings of the team on the four components, was also required and is supplied herein.

The contract for the solid-state TACAN receiver-coder was let on 18 February 1961; however, it was altered on 1 March 1962. The receiver-coder was sent to the technical monitor at Fort Dawes, Massachusetts, during the first part of June 1963, but was rejected by the technical monitor because it had not been subjected to its required tests. The receiver-coder was made available to the team on 19 November 1963. The circuit schematics were received in late December 1963; however, the final report was never received.

A contract for a semi solid-state TACAN monitor was let on 20 May 1961 and altered on 20 March 1962. The monitor was at Fort Dawes by the time the Montek four-man team arrived.

A contract was let in April 1961 for a semi solid-state TACAN transmitter, employing a spectrum-controlling feedback loop. The transmitter was received at Fort Dawes on 8 August 1963.

A contract was also let for a solid-state TACAN identification keyer in February 1961. The keyer was at Fort Dawes when the Montek team arrived.

The experimental AN/URN-3 TACAN equipment at Fort Dawes was set up and placed in test bed operation by the team so that it could be used for reference and integrating purposes. Internal component failure and design problems found in the major solid-state components were resolved such that the components were made operational. A number of solid-state TACAN system interface problems were then resolved in order that the integration of the major components could be achieved.

After the solid-state components were integrated, and the components (duplexer, mixer, antenna, and monitor antenna), which had not been provided to make up a complete TACAN transponder beacon, were borrowed from the AN/URN-3 test bed and integrated with the solid-state components, the AN/ARN-21 airborne interrogator-responder was set-up and utilized to interrogate and receive signals from the

solid-state TACAN system. (See Figure A)

Azimuth lock-on and identity response using the solid-state transponder beacon and the AN/ARN-21 was achieved on 24 January 1964, and DME lock-on was achieved on 27 January 1964. The accomplishment of response to TACAN interrogation (azimuth, DME, and identity response) demonstrated that solid-state TACAN equipment was not beyond the state-of-the-art.

Progress reports concerning the work being performed by the team were submitted to the USAF. Copies of these reports are included in Appendixes II and III for reference purposes. The work performed on this contract, which was not covered in the previous reports, has been described in Section 1 of this report.

Montek wishes to acknowledge appreciation to the following individuals who assisted and guided the four-man team in the performance of this contract:

To Mr. B. F. Greene Jr., ESSVM, under whose office this contract was originated and monitored;

To Mr. Joseph E. Reagan, technical monitor, who aided the team through the major component integrations and provided guidance in the preparation of the required characteristic for each of the major solid-state components (reference Appendix I);

To Mr. Val Allred, Montek Field Representative for Contract AF 19(628)-3246, for his guidance on the AN/TRN-17 TACAN system, while he was located at Fort Dawes and associated with the 482L Systems Program Office (ESD); and

To the solid-state transmitter vendor representative, who confirmed some of the team's findings and test results involving the solid-state transmitter.

The information contained in this report reflects the views of Montek's Navigational Aids Department, and does not necessarily reflect the views of the USAF.

This report constitutes the final contractual requirement upon Montek for Contract AF 19(628)-3263.

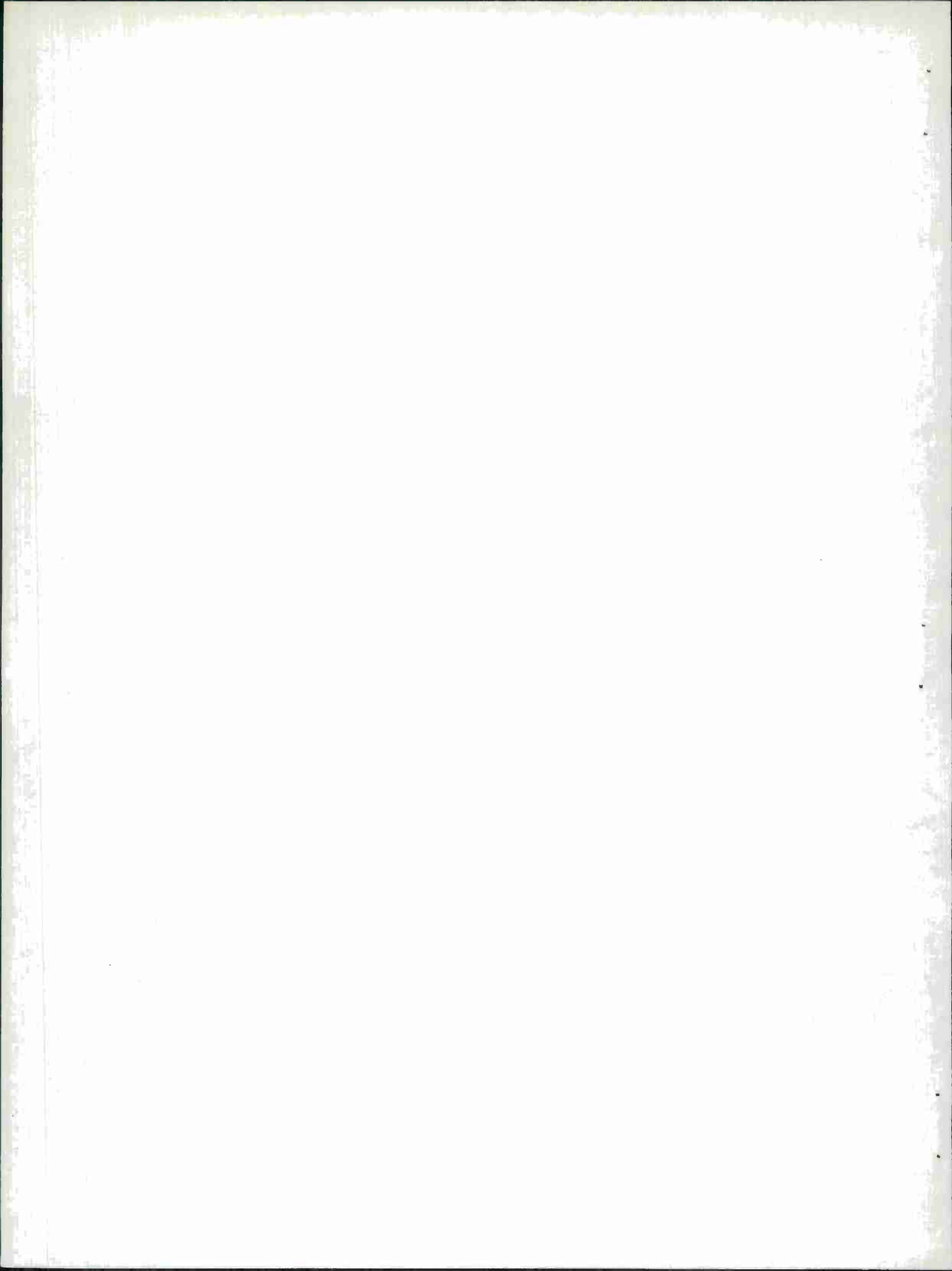

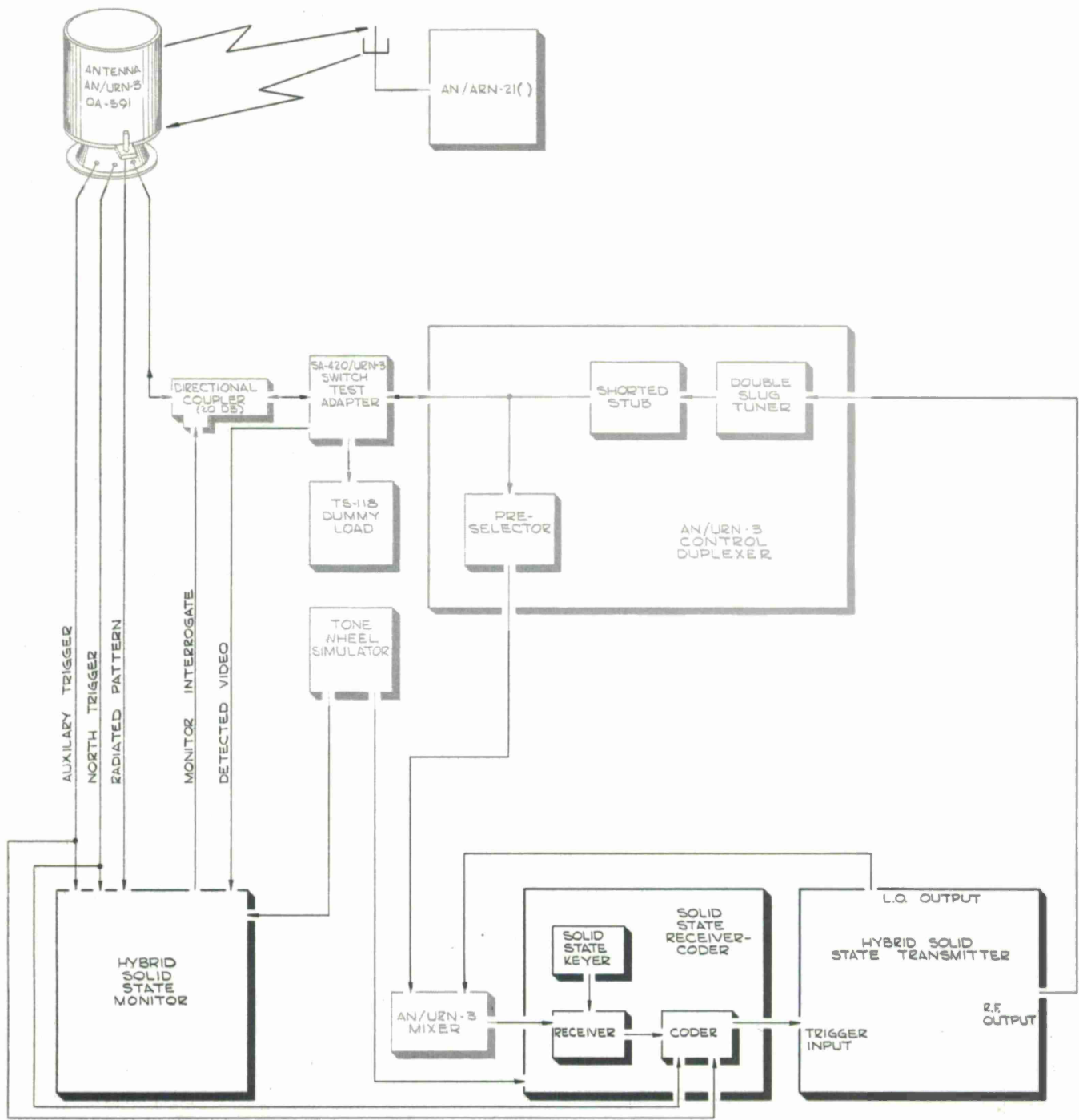

**MONTEK INC.**  
SALT LAKE CITY, UTAH

A DIVISION OF  
**MODEL ENGINEERING & MANUFACTURING CORP.**  
HUNTINGTON, INDIANA

---

**SOLID STATE TRANSPONDER  
& MONITOR TEST BED**

---

<small>DRAWN BY</small> R. WARD	<small>NAV. AIDS DEPT.</small>
<small>DATE ISSUED</small> 28 AUGUST 1964	<small>DRAWING NO.</small> 64-234-1

**FIGURE -A**

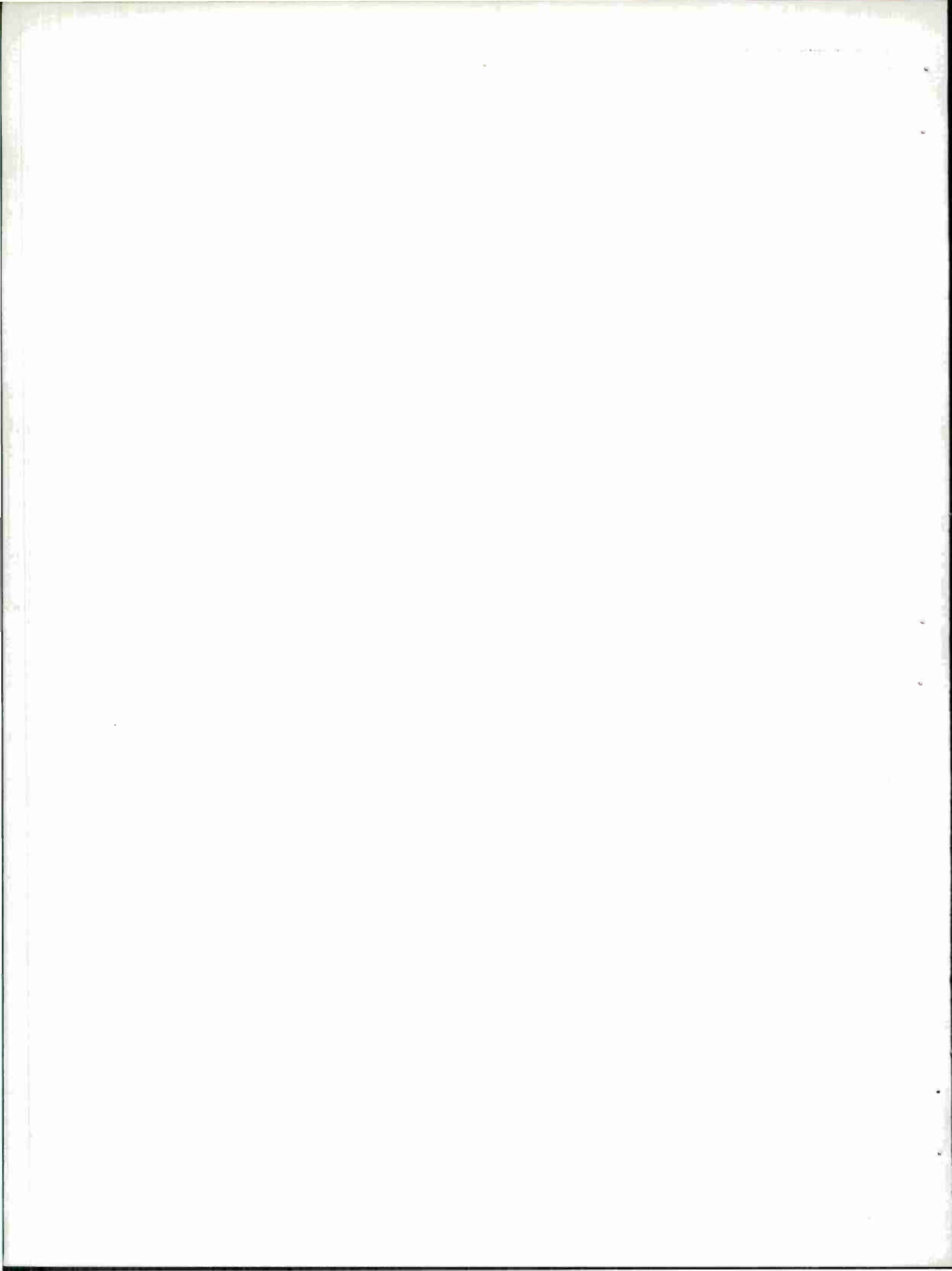

## ABSTRACT

The objective of contract AF 19(628)-3263 was to perform the necessary design, development, and fabrication of circuitry required for integrating the major solid-state components and sub-systems provided by various vendors into an experimental solid-state TACAN transponder beacon and monitor, and to evaluate these components as sub-systems and as a complete TACAN transponder system with monitor. Characteristics (see Appendix I) were also to be provided which would aid the USAF in realizing a complete specification for an advanced solid-state TACAN ground system that would satisfy the present USAF EMS TACAN needs.

The four-man team provided by Montek accomplished the following during the course of this contract:

- (a) Resolved the problems found in the major solid-state components (sub-systems) previously procured;
- (b) Solved the interface problems between the solid-state components;
- (c) Integrated the major components into a solid-state TACAN ground transponder beacon with monitor;
- (d) Maintained and utilized an airborne interrogator-responder (AN/ARN-21) to assist in the testing of the solid-state transponder breadboards; and
- (e) Performed tests to compare the parameters of the solid-state transponder with the AN/URN-3 test bed (which the Montek team set-up and maintained while at Fort Dawes, Massachusetts).

The USAF, under the conditions of the contract, was to provide the Montek team with an AN/TRN-17 set; however, since an AN/TRN-17 was unavailable, the team improvised (using AN/URN-3 components) to overcome the resultant deficiencies.

Upon completion of the integration and testing of the solid-state major components, the team, with the aid of Montek's Navigational Aids Department, prepared a characteristic for each of the four major solid-state TACAN components and for



a solid-state integrated test equipment package (see Appendix I).

It is recommended that the TACAN test bed maintained by the Montek team be installed and utilized as an experimental test bed at a site (selected by the USAF) which would be desirable for the testing of all TACAN parameters, including antenna flight test work.

Due to the basic deficiencies in the solid-state major components (breadboards) integrated and tested by the team under this contract, it is recommended that this solid-state test bed remain with the experimental facility and be used for experimental purposes only. Montek does not recommend that the USAF attempt to operationally utilize this particular solid-state transponder and monitor (breadboards).

This report and the characteristic contained herein are based on solid-state TACAN system analysis work, solid-state TACAN test results, solid-state TACAN integration work, and extensive experience in the TACAN field. It is recommended that the USAF initiate, at an early date, the continuance of the characteristic phase (see Appendix I) of contract number AF 19(628)-3263 in a manner suggested in a letter proposal by Montek's Navigational Aids Department, Salt Lake City, Utah, entitled "State-of-the-Art Solid-State TACAN Equipment Characteristics," dated 4 September 1964.

#### REVIEW AND APPROVAL

This technical documentary report, ESD-TDR-64-548, has been reviewed and is approved.

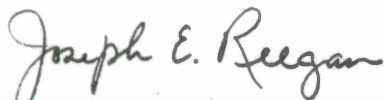

JOSEPH E. REEGAN  
Technical Contract Monitor

T A B L E O F C O N T E N T S

<u>Section</u>	<u>Page</u>
FOREWORD .....	ii
ABSTRACT .....	vi
1 INTRODUCTION .....	1
1.1 Summary of Progress from July 15, 1963, to January 31, 1964	1
1.2 Summary of Progress from January 31, 1964, To The End of the Contract Time .....	2
2 THEORY OF OPERATION OF THE SOLID-STATE TACAN TEST BED MAJOR COMPONENTS .....	5
2.1 General .....	5
2.2 Operation of the Receiver-Coder .....	6
2.3 Operation of the Solid-State Keyer .....	15
2.4 Operation of the Solid-State Transmitter .....	17
2.5 Operation of the Solid-State Monitor .....	26
3 MODIFICATIONS AND INTERFACE PROBLEMS .....	43
3.1 General .....	43
3.2 Problems Involving the Receiver-Coder Component .....	43
3.3 Transponder Interface .....	48
3.4 Interface and Internal Circuits Involving the Solid-State Monitor .....	49
3.5 Monitor Interface .....	52
4 TACAN TEST RESULTS .....	63
4.1 General .....	63
4.2 Transponder Test Results .....	63
4.3 Monitor Test Results .....	75
4.4 Shaper Module .....	77
4.5 Solid-State Gate Modulator .....	78
5 CONCLUSIONS AND RECOMMENDATIONS .....	80
5.1 Solid-State Components .....	80
5.2 Test Bed Facility .....	82
5.3 Advanced Solid-State System .....	83
5.4 Characteristic .....	84

Supplementary Material

APPENDIX I	MILITARY CHARACTERISTIC FOR BEACON-TRANSPONDER SET, TACAN, AN/TRN-( ) .....	85
APPENDIX II	PROGRESS REPORT #1, CONTRACT NO. AF 19(628)-3263 ..	201
APPENDIX III	PROGRESS REPORT #2, CONTRACT NO. AF 19(628)-3263 ..	212

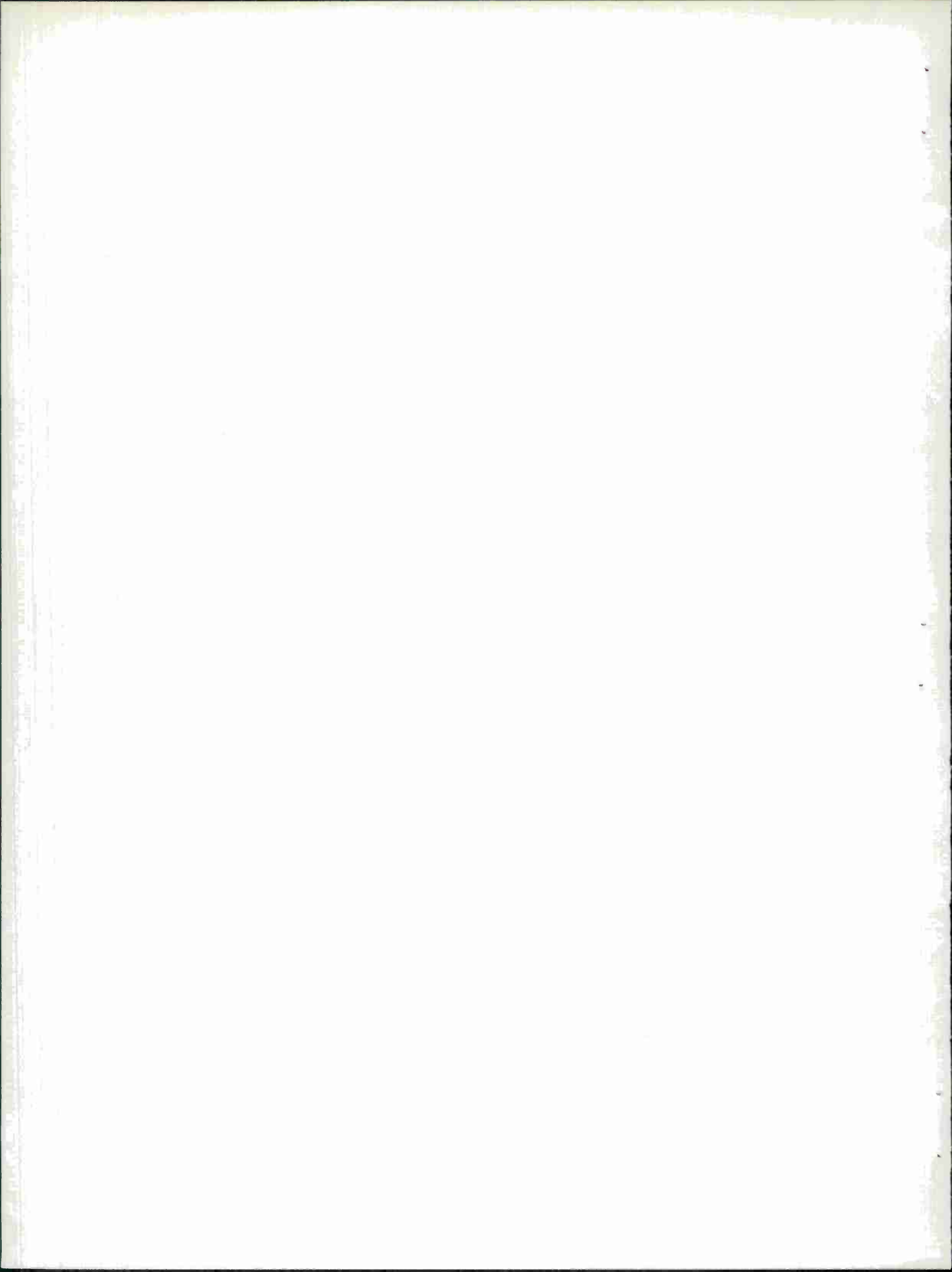

## SECTION 1

### INTRODUCTION

#### 1.1 Summary of Progress from July 15, 1963, to January 31, 1964

- 1.1.1 After the award of Contract AF 19(628)-3263 to Montek, and prior to the arrival of the four-man team at Fort Dawes, Massachusetts, members of the team were given an extensive TACAN refresher course at Montek, which involved various types of TACAN facilities and TACAN concepts. Upon arrival at Fort Dawes, the team proceeded to place the facility in order and to locate the TACAN components and test equipment which were government provided on this contract.
- 1.1.2 The AN/URN-3 TACAN had been installed prior to the arrival of the four-man team, but had not been made operational; therefore, the team began immediately to eliminate the problems which had rendered the AN/URN-3 inoperative as a test bed. The AN/URN-3 experimental TACAN was operated and maintained by the four-man team throughout the contract period.
- 1.1.3 Inasmuch as a TACAN RF test pulse generator and spectrum analyzer was not available, but was required by the team for system test and evaluation purposes, TS-890 type pulse-analyzer/test-generators were loaned to the team by government agencies on two separate occasions for extended periods.
- 1.1.4 Two of the four solid-state major components, which the team was to receive during the course of the contract, had arrived at Fort Dawes prior to the arrival of the team. These components were the solid-state keyer and the hybrid solid-state monitor. The hybrid transmitter (15 thermionic tubes were used), which will be referred to throughout this report as the solid-state transmitter, was received at Fort Dawes shortly after the arrival of the team. The major components which were received contained many internal problems, primarily in the monitor, such as damaged circuit components, many no-solder or bad-solder joints, circuit components

improperly connected, and erroneous circuitry schematics which had to be corrected. After the major component internal problems had been resolved, the team began the task of resolving the component interface problems, which involved drive signal amplitude, impedance matching, and timing. For a detailed description of the various internal and interface problems that were resolved, see Section 3 of this report.

1.1.5 The quantity and type of vendor provided solid-state experimental TACAN components required to make (for test and evaluation) a solid-state (breadboard) transponder and monitor operative was insufficient. As a result of this fact, the Montek team obtained the lacking components, such as the duplexer, mixer, and TACAN antenna (OA-591) from the AN/URN-3 test bed.

1.1.6 On January 27, 1964, the solid-state transponder and monitor, along with the AN/URN-3 components, was functioning as an experimental solid-state test bed. The AN/ARN-21 interrogator-responder was placed in one of the bunkers at Fort Dawes (because of excessive radiation from the solid-state transmitter) and was used to interrogate and receive replies from the solid-state transponder test bed.

1.1.7 For more details concerning the work which was performed under Contract AF 19(628)-3263 from July 15, 1963 to January 31, 1964, two progress reports are provided in Appendixes II and III of this report.

1.2 Summary of Progress from January 31, 1964, To The End of the Contract Time

The following work was performed after the solid-state transponder had been successfully interrogated:

1.2.1 Improving Operation of the Solid-State Transponder

The following work was performed to improve the operation of the transponder after successful interrogation and reply had been achieved:

- (a) The receiver sensitivity was increased;
- (b) The frequency spectrum of the transmitter RF output pulse was improved by altering the operation of the feedback loop and the

biasing of the final RF amplifier; and

- (c) Temporary circuitry was added to the test equipment to improve testing capabilities.

#### 1.2.2 Tests

Numerous tests were performed to compare the operation of the solid-state transponder with the AN/URN-3 test bed. The results of these tests are recorded in Section 4 of this report.

#### 1.2.3 Characteristic

Contract AF 19(628)-3263 required that a characteristic be developed for the solid-state major components, which were supplied by the USAF; however, since the major components did not consist of a complete TACAN ground set, and since the components had so many shortcomings, the following approach was taken in developing the characteristic.

##### 1.2.3.1 Evaluation of Major Components

The major components were evaluated to determine how well they supplied the needs of a TACAN ground set, which would not be classified as inferior or obsolete. The desirable features of the components were retained for use in preparing the applicable characteristic, while the undesirable features were improved upon, replaced by better methods, or discarded as dictated by the requirement of a highly useful and up-to-date characteristic.

##### 1.2.3.2 Investigations Throughout the TACAN Field

The four-man team, with the assistance of the Montek Navigational Aids Department, investigated the following:

- (a) The needs of the TACAN customer as pertains to EMS;
- (b) The feasibility of the use of new products in the TACAN field;
- (c) The reliability and features of existing TACAN facilities;
- (d) Marginal operating functions, such as pulse distorting echoes, azimuth errors, antenna problems, etc., which are

currently found in TACAN ground systems; and

- (e) The need for additional features and new concepts which would greatly enhance TACAN flying safety.

#### 1.2.3.3 Compiling Findings

Where applicable, the results of this investigation were used as a guide in writing the particular characteristics which were required.

#### 1.2.4 Shift in Team Personnel

Testing of the solid-state transponder and monitor breadboards by the four-man team was nearing completion by mid-March, 1964, and the work load was beginning to shift from the required technician work to the technical writing portion of contract. At this time, Mr. K. C. Eder was released from the team and Contract AF 19(628)-3263 to pursue other work at Montek, and additional technical writing support was received by Montek in Salt Lake City.

#### 1.2.5 Other Items Which Occurred During The Course of the Contract

1.2.5.1 The Montek team demonstrated some of the capabilities of the solid-state transponder and monitor breadboards to USAF maintenance personnel from L. G. Hanscom Field.

1.2.5.2 Since the experimental TACAN test bed was to be moved from Fort Dawes and relocated at L. G. Hanscom Field, the USAF technical monitor requested the assistance of the team in preparing a new TACAN test bed equipment floor plan. This assistance was provided and the floor plan completed; however, the new test bed site located at L. G. Hanscom Field (on base) is highly undesirable insofar as antenna experimental work is concerned. The site is totally unsuited for flight testing and antenna radiation pattern testing due to the presence of nearby large reflecting objects. It is suggested that a review of this probable future test bed problem be considered.



## SECTION 2

### THEORY OF OPERATION OF THE SOLID-STATE TACAN TEST BED MAJOR COMPONENTS

#### 2.1 General

- 2.1.1 The following discussion describes the theory of operation of the major solid-state components which were provided by the USAF as part of this contract.
- 2.1.2 Block diagrams and waveforms, which have been referenced in their associated written material, have been provided to aid in the description of the operation of the major components.
- 2.1.3 The information and schematics contained in this section of the report are provided to supplement the "Theory of Operation" of the solid-state components (which was provided with the solid-state components) in the areas where insufficient information was provided, and to correct the areas where errors in the "Theory of Operation" existed.
- 2.1.4 This section of the report also describes the operation of the system after the major components had been integrated.

## 2.2 Operation of the Receiver - Coder (Reference Figure 2.1)

### 2.2.1 General

The interrogate pulse pair (1025 to 1150 Mc) is received at the TACAN antenna and is sent to the SA-420 coaxial switch. From the SA-420 coaxial switch, the pulse pair progresses through the preselector, located in the control duplexer, and is coupled to the balanced "T" mixer located in the receiver-coder. The output signal of the balanced "T" mixer is the interrogate pulse pair, with a carrier frequency of 63 Mc. The mixer output signal is coupled to the IF strip input (TP1).

### 2.2.2 IF Strip

The solid-state IF strip contains 10 double tuned stages. The first stage serves as a preamplifier followed by five amplifier stages, whose gains are controlled automatically (AGC). The bandpass of the IF strip is 2 Mc (62 to 64 Mc).

### 2.2.3 Ferris Discriminator

The IF strip output signal is fed to the Ferris Discriminator (TP2). The Ferris Discriminator detects the interrogate pulse pair and provides adjacent channel rejection. The Ferris Discriminator contains two adjustable tank circuits. The low Q tank has a bandpass of 1.75 Mc (62.12 to 63.87 Mc) (TP3) and the high Q tank has a bandpass of 1.0 Mc (62.50 to 63.50 Mc) (TP4). The overall Ferris Discriminator circuitry has a bandpass of 0.75 Mc (62.62 to 63.37 Mc). The detected output pulse pair of the Ferris Discriminator continues through

two stages of amplification and is applied to the Decoder Module (TP5).

#### 2.2.4 Decoder Module

The interrogate pulse pair (now video) is amplified by two more stages in the front end of the Decoder Module and is applied to the decoding and blanking circuitry (TP6). This coincidence type double pulse decoder circuit utilizes a 12  $\mu$ sec delay line in its decoding process. The decoder will decode those pulse pairs which have between pulse spacings of 9.9 to 15  $\mu$ secs (within  $\pm 0.5$   $\mu$ sec, dependent upon interrogate pulse pair amplitude). After each pulse pair is decoded (TP7), the decoder is blanked for a period of 47  $\mu$ secs by the output pulse from the Blanking Time Multivibrator via an OR circuit and an output amplifier located within the Identity Module (TP8). The output pulse of the decoder circuit (TP9) is amplified and applied to the precedence circuit of the Identity Module (TP10).

#### 2.2.5 Identity Module

2.2.5.1 The precedence circuit of the Identity Module establishes priority for the identity tone output over interrogate or squitter pulses. Priority is established in the following manner. Normally, the solid-state keyer outputs are at +20 VDC, permitting a decoder output and preventing the identity tone from receiving precedence. When a dot or dash (code) is to be transmitted, the keyer output decreases

to ground. This grounded condition provides forward biasing of precedence diodes (within the Identity Module) to occur, thus permitting identity tone to be transmitted. The grounded condition of the keyer output holds the decoder output at ground, thereby shutting off the interrogation and squitter pulses during identity transmission. The output trigger signal of the precedence circuit (TP11) is sent to a 14  $\mu$ sec multivibrator.

- 2.2.5.2 The 14  $\mu$ sec multivibrator output signal (TP12) is sent to four points:
- (a) The blanking time multivibrator, which in turn generates the blanking signal for the decoder, after each decoded interrogate or squitter pulse;
  - (b) The OR circuit of the identity module;
  - (c) The AGC module, which controls the gain of the IF strip; and
  - (d) The delay line driver of the coder portion of the receiver-coder.

- 2.2.5.3 The output pulses (either interrogate, squitter, or identity pulses) of the 14  $\mu$ sec multivibrator trigger the blanking time multivibrator, which is adjustable from 5 to 52  $\mu$ secs. The blanking time multivibrator output (TP13) is applied to the OR circuit of the identity module. Output signals from the 14  $\mu$ sec multivibrator (TP12) and the timing module (TP14)

are also applied to the OR circuit. Therefore, the output signal of the OR circuit is a pulse (TP15) which consists of the 14  $\mu$ sec multivibrator pulse (identity module output) plus the blanking time multivibrator output, for all identity, interrogations, and squitter pulses. The input signal to the OR circuit from the timing module insures that the decoder is blanked when azimuth information (reference bursts) is being generated. The OR circuit output signal is amplified and sent to the decoder and blanking circuit of the decoder module (TP8).

2.2.5.4 Identity tone double pulse generation occurs in the identity module. A 1350 cps tone is received from a TS-382B/U audio oscillator (TP16) and is amplified by two stages, thereby squaring up the 1350 cps signal to an approximate square wave (TP17). The negative-going edge of the trigger pulse is differentiated and used to trigger a 100  $\mu$ sec multivibrator (TP18). Two output signals, a positive pulse (TP19) and a negative pulse (TP20), of the 100  $\mu$ sec multivibrator are used. Both pulses are differentiated (TP21 and TP22) and applied to the precedence circuit in the identity module. When squitter is being transmitted, the precedence diodes are reversed biased (TP23). When a "dot" or a "dash" (code) from the keyer module is to be transmitted, the precedence diodes are forward biased, and the negative spikes

(TP24) of the differentiator circuit, separated by 100  $\mu$ secs, are applied to the 14  $\mu$ sec output multi-vibrator of the identity module (TP11 waveform A). The output signal of the identity module is a pair of 14  $\mu$ sec pulses, separated by 100  $\mu$ secs, and occurs at a rate of 1350 cps or 2700 pulses per second (TP12 waveform B & C).

#### 2.2.6 AGC Module

Identity module output pulses are also applied to the AGC module. Pulses applied to the AGC module are amplified and sent to a level shifter driver circuit, which filters the pulses to a DC level which is dependent upon the pulse repetition rate and the setting of the AGC level control reference circuit. This DC voltage is applied to the driver circuit of the AGC module, the output of which adjusts the IF amplifier gain to maintain an output pulse rate of 2700 pulses per second, or as set by the AGC level reference control. During a condition of an excess number of pulses out of the identity module, the following sequence would occur: The input signal to the level shifter driver would become negative; the output signal of the level shifter driver would become more positive; hence, the AGC control voltage would shift positive, thereby decreasing the IF gain. The reduction in IF gain would decrease the number of pulses out of the IF strip; therefore, the number of pulses out of the identity module and into AGC module would decrease. Due to the decrease in output repetition rate identity module, the level shifter driver input would

become less negative, and control is achieved. The opposite control action occurs in the case of a deficiency of pulses out of the identity module.

#### 2.2.7 North Burst Module

The 15 cps trigger pulses from the antenna pulser coil are fed to the north burst module of the coder portion of the receiver-coder. The 15 cps north trigger pulses (TP28) are coupled to the north trigger amplifier. The output pulse (TP29) of the trigger amplifier simultaneously fires two multivibrators (the north gate multivibrator, located in the north burst module, and the 30  $\mu$ sec multivibrator, located in the delay line driver), when negative crossover of the north antenna trigger pulse occurs. The north gate multivibrator provides positive and negative output pulses, which are both 375  $\mu$ secs in duration. The negative gate output pulse (TP30) is coupled to the delay line driver precedence circuit, thereby establishing priority of north azimuth information over any signal (identity, interrogations, or squitter) arriving from identity module. The positive gate output pulse (TP31) is coupled to the north burst summing circuit. The output signal of the delay line driver 30  $\mu$ sec multivibrator (TP32) is also coupled to the north burst summing circuit. The output signal of the summing circuit (TP33) is coupled to an amplifier whose output signal is a negative gate, delayed 30  $\mu$ secs from the north trigger cross-over point, and is 345  $\mu$ secs in duration (TP34). This 345  $\mu$ sec negative gate output signal is applied to an AND gate circuit. The delay line driver 30  $\mu$ sec multivibrator output signal (TP32) is



also sent to the AND gate circuit (TP35). After amplification of the output signal of the AND circuit (TP36), the amplified signal is differentiated (TP37). The differentiated signal triggers a four  $\mu$ sec multivibrator (TP38) in the delay line driver. The output pulse of the four  $\mu$ sec multivibrator (TP39) is amplified (TP40) and is coupled to the delay line where it is delayed 30  $\mu$ secs. The output signal of the delay line, Tap 2 (TP41), is then coupled back to the AND circuit in the north burst module (TP35), initiating another pulse. The "ring-around" cycle continues until the AND gate is shut off at the end of the 345  $\mu$ sec output gate in the summing circuit (TP34). At the time of the AND gate shut-off, a train of twelve pulses, each four  $\mu$ secs wide and separated by 30  $\mu$ secs, has been generated (TP36 waveform A).

#### 2.2.8 Auxiliary Burst Module

The auxiliary burst is generated in the same manner as the north burst, the only difference being the width of the output signal of the auxiliary burst module gate multivibrator which is 165 instead of 375  $\mu$ secs, and the signal delay from the delay line, Tap 1, which is 24  $\mu$ secs instead of 30  $\mu$ secs. The train of pulses generated is therefore a train of six pulses, each four  $\mu$ secs wide and separated by 24  $\mu$ secs.

#### 2.2.9 Delay Line Driver Module

Operation of the precedence circuitry in the delay line driver module is as follows:

- 2.2.9.1 Under the conditions when an interrogate pulse occurs at the input to the precedence circuitry (TP43) located in the delay line driver module, and when no north or

auxiliary gate pulses have occurred at the precedence circuitry, the interrogate pulse is first amplified (TP44) and then triggers the four  $\mu$ sec multivibrator input (TP45). The output pulse of the four  $\mu$ sec multivibrator (TP39 waveform A) is amplified (TP40 waveform B) and coupled through the delay line to the timing module.

2.2.9.2 Under the conditions when an interrogate pulse occurs (TP43) and when a negative blanking gate pulse (TP30) from the north burst module occurs at the precedence circuitry, the blanking gate pulse prevents any output signal from the precedence circuitry from occurring for 375  $\mu$ secs. After north precedence is established in the above manner, a pulse from the north burst module triggers the four  $\mu$ sec multivibrator (TP38). The output signal from the four  $\mu$ sec multivibrator triggers the circuitry, which creates the north burst "ring-around" action as described previously.

2.2.9.3 When precedence is established with a blanking gate pulse from the auxiliary burst module, the same relative conditions occur, except that precedence is established for a shorter period of time (165  $\mu$ secs) and the four  $\mu$ sec multivibrator output pulses are delayed in the delay line by 24  $\mu$ secs. The result of the shorter precedence time and shorter delay time is a train of six pulses spaced 24  $\mu$ secs apart, as seen at Tap 3 or Tap 4.

### 2.2.10 Delay Line

The delay line has two output signal taps (3 and 4) which provide for two pulses to be coupled to the timing module for every single pulse out of the delay line driver. Both taps can be individually adjusted for between pulse spacing or mechanically locked together and adjusted to provide system delay; i.e., Tap 3 adjusts pulse spacing (12  $\mu$ secs) and Tap 4 adjusts system delay (50  $\mu$ secs).

### 2.2.11 Timing Module

2.2.11.1 The output pulse from Tap 3 (TP48) is coupled to an amplifier. After amplification, the pulse (TP49) triggers a 14  $\mu$ sec multivibrator. The output pulse from Tap 4 is delayed 12  $\mu$ secs in reference to Tap 3 (TP51) before it is applied to an amplifier. After amplification, the delayed pulse (TP52) also triggers a 14  $\mu$ sec multivibrator. Both 14  $\mu$ sec multivibrators have a positive and a negative output signal.

2.2.11.2 The positive 14  $\mu$ sec pulse gates (TP50 and TP53) from both 14  $\mu$ sec multivibrators are applied to an OR circuit in the timing module, which drives an emitter-follower whose output signal (TP14) is applied to the OR circuit in the identity module.

2.2.11.3 The negative 14  $\mu$ sec pulse gates (TP54 and TP55) from both multivibrators are differentiated, and the differentiated pulses trigger a four  $\mu$ sec multivibrator (TP56). Since the 14  $\mu$ sec multivibrator output pulses occur

12  $\mu$ secs apart, the output signal of the four  $\mu$ sec multivibrator is a pulse pair spaced 12  $\mu$ secs apart as measured from the leading edge of the first pulse to the leading edge of the second pulse (TP57). The output signal of the four  $\mu$ sec multivibrator is coupled to an emitter-follower, whose output signal is coupled to the transmitter input (TP58).

### 2.3 Operation of the Solid-State Keyer (Reference Figure 2.1)

2.3.1 The solid-state keyer provides the same functions as a mechanical keyer; however, there are no moving parts within the solid-state keyer.

2.3.2 The solid-state keyer consists of three modules, plus a 21-bit magnetic shift register and its related switching network. A detailed theory of operation of the keyer may be found in "Technical Documentary Report No. ESD-TDR-63-340", dated January 1963.

2.3.3 Transmission of the code occurs every 30 seconds. A 30-second multivibrator in the initial pulse circuit in conjunction with the keyer clock pulse will transfer a new binary "1" pulse (bit pulse) into the first core of the shift register 30 seconds after a previous binary "1" insertion. The "1" must be inserted into the first core at the proper time, with respect to the shift pulse. After the initial "1" pulse has been inserted, clocking pulses, which are generated by a 250 millisecond clock generator, will shift the "1" pulse through the shift register at the clock rate.

- 2.3.4 Only one bit will be in the shift register at any time. The bit will continue to shift down the register until it is shifted out of the last core and lost. The magnetic register operating procedure repeats itself every 30 seconds with a new "1" pulse inserted into the first register core.
- 2.3.5 The desired code pattern is generated by connecting the pulse output from each core to the dot or dash lines that drive their respective one-shot multivibrators. Each core output may be connected to provide either a dot or a dash code. A space will occur when the output of a core is not connected to either the dot or the dash line.
- 2.3.6 The dot interval (125 milliseconds) and the dash interval (375 milliseconds) are produced by one-shot multivibrators. The output of these multivibrators are then coupled to an OR gate and subsequently to the output keying stage, which keys the identity tone off and on. The output circuitry of the keyer, normally at +20 VDC, must be grounded during transmission of identity pulses to be compatible with the receiver-coder circuitry (reference Paragraph 2.2.5). Grounding of the keyer output is accomplished by the output keying stage, which receives dot and dash pulses from the OR gate.
- 2.3.7 The one-shot multivibrators that form the dot and dash intervals are triggered from the shift register with a clock period of 250 milliseconds. The dot occupies half of the 250 millisecond clock pulse; hence, a 125 millisecond dead time period follows the dot. This arrangement automatically provides the interval (125 milliseconds) between successive dots and dashes of a character. The 375 millisecond dash period is generated by coupling

the 375 millisecond output signal from the dash generator to inhibit the first clock pulse which follows the leading edge of the dash pulse. A dead time period of 125 milliseconds follows the dash before the next clock pulse occurs.

## 2.4 Operation of the Solid-State Transmitter (Reference Figure 2.2)

### 2.4.1 General

Coded pulse pairs, which consist of azimuth, identity, interrogations (distance), or squitter information, are received from the receiver coder at the input jack of the transmitter (TP59). These signals are coupled to a 13  $\mu$ sec delay line and to two trapezoidal generators.

### 2.4.2 Trapezoidal Generator Number One

The two trapezoidal generators produce output signals which are similar to trapezoid wave shapes. The number one trapezoid generator provides an output waveform which is approximately 44  $\mu$ secs in duration, measured at one-half amplitude points, and is 24 volts in amplitude (TP60). This trapezoidal output signal is coupled to cathode modulators two, three, and four.

### 2.4.3 Trapezoidal Generator Number Two

The number two trapezoid generator provides an output waveform which is approximately 35  $\mu$ secs in duration, measured at the one-half amplitude points, and is 24 volts in amplitude (TP61). This output waveform is coupled to cathode modulator number one.

### 2.4.4 $\text{Cos}^2 \theta$ Generator

The output signal of the delay line (TP62) is coupled to a  $\text{Cos}^2 \theta$  generator and to a sync and delay line module. The  $\text{Cos}^2 \theta$  generator produces an output signal similar to a  $\text{Cos}^2 \theta$

waveform. For every input trigger pulse from the receiver-coder, a  $\text{Cos}^2 \theta$  waveform is generated. The  $\text{Cos}^2 \theta$  waveform is approximately 3.9  $\mu\text{secs}$  wide, measured at one-half amplitude points, and is five volts in amplitude (TP63). This output signal is coupled to the four cathode modulators.

#### 2.4.5 Cathode Modulators

Each cathodemodulator sums and inverts the trapezoidal and  $\text{Cos}^2 \theta$  waveforms, and couples the summed waveforms to the cathodes of their respective RF amplifiers (i.e., number one modulator provides modulation for number one RF amplifier). Since the  $\text{Cos}^2 \theta$  pulses are delayed 13  $\mu\text{secs}$  more than the trapezoidal pulses, the  $\text{Cos}^2 \theta$  pulses are approximately centered on the trapezoidal output waveforms (TP64, TP65, TP66, and TP67).

#### 2.4.6 Sync and Delay Line and Reference Generators One and Two

The sync and delay line module generates the start and stop pulses for triggering the reference generators. Two reference generators are utilized to develop the reference pulses; therefore, each generator develops one of the pulses in a reference pulse pair. The use of the dual generators eliminates the need for fast recovery circuits in the reference generator and assures a stable waveform. The only difference between the two reference generators is the timing of the start and stop trigger pulses applied to them from the sync and delay line. The operation of Reference Generator Two, which generates the first pulse of the reference pulse pair, will now be discussed. (The second reference pulse is generated in the same manner.) Start



pulses are coupled from the sync and delay line module to two identical multivibrators located in Reference Generator Two. Stop pulses are coupled in a similar manner from the sync and delay line module to the same multivibrators in Reference Generator Two approximately 10.5  $\mu$ secs later. The output signal of one multivibrator is coupled to a  $\text{Cos}^2 \theta$  generator, which generates one  $\text{Cos}^2 \theta$  pulse (TP68). The output signal of the other multivibrator is coupled to a  $-\text{Cos}^2 2\theta$  generator, which generates two  $-\text{Cos}^2 2\theta$  pulses (TP70). The  $\text{Cos}^2 \theta$  and  $-\text{Cos}^2 2\theta$  pulses from Reference Generator Two are applied to the Difference Amplifier of Reference Generator Two. The  $\text{Cos}^2 \theta$  and  $-\text{Cos}^2 2\theta$  pulses from Reference Generator One are also applied to the Difference Amplifier of Reference Generator Two (TP69 and TP71). The output signals of the  $-\text{Cos}^2 2\theta$  generators are inverted in the Difference Amplifier of Reference Generator Two (TP72); however, the output signals of the  $\text{Cos}^2 \theta$  generators are not inverted (TP73). The output pulse pair of the Difference Amplifier is two  $\text{Cos}^4 \theta$  pulses (TP74), which are due to the combination of the  $\text{Cos}^2 \theta$  and the  $-\text{Cos}^2 2\theta$  pulses. (It can be shown that  $\text{Cos}^4 \theta = \text{Cos}^2 \theta + \frac{1}{2} \text{Cos}^2 2\theta - \frac{1}{2}$ .) Therefore, a reference pulse pair is generated and coupled to the Difference Amplifier in the spectral feedback loop.

#### 2.4.7 Oscillator Power Driver

2.4.7.1 Two oscillator power drivers and two broadband multipliers are required for the

transmitter, one of each for high band (1151 to 1213 Mc) and one of each for low band (962 to 1024 Mc) operation.

2.4.7.2 The oscillator is a Hartley type, using crystal controlled frequency generation. The CW output signal of the oscillator (1 to 2V rms) is coupled to the power driver, a three-stage tube amplifier through which the input CW power is amplified to 10 watts.

#### 2.4.8 Broadband Multiplier

2.4.8.1 The crystal controlled frequency output signal of the power driver is coupled to a broadband multiplier, which multiplies the crystal oscillator frequency by a factor of 24. The broadband multiplier employs a tripler and three doublers in this multiplication. Since the broadband multiplier is 10% efficient, with 10 watts coupled into the broadband multiplier, one watt of output power at transmit frequency is provided at the output of the broadband multiplier. A minimum broadband multiplier output power of one watt is required to drive the RF amplifier chain. It should be noted that the broadband multiplier is a passive device, utilizing three varactors and tuned circuitry for multiplying the power driver output crystal frequency.

2.4.8.2 The RF power output of the broadband multiplier is coupled to a 15 db directional coupler. At this directional coupler, a portion of the transmit frequency power is tapped off and provided at a local oscillator output jack for use in the mixer circuitry of the receiver. The non-attenuated output of the 15 db directional coupler is applied to the first cavity of the RF amplifier chain.

#### 2.4.9 RF Amplifier Chain

The RF amplifier chain consists of four tuned cavities, using the RCA 7649 Tetrode type tube. Each cavity is tuned by varying the lengths of the cathode cavity, screen cavity, and plate cavity. Input and output couplers are also adjustable on each cavity. A directional coupler is located at the output of each stage of the RF amplifier chain. The directional couplers on the output of cavities one, two, and three are 20 db couplers, and the directional coupler on the output of cavity number four is a 30 db coupler.

2.4.9.1 The following voltages and signals (typical) are applied to number one cavity (RCA 7649) when the transmitter output waveform is conforming to the reference signal:

- (a) Plate - +700 V
- (b) Screen-grid - +300 V
- (c) Control grid--grounded
- (d) Cathode Modulator applied at +36 VDC level
- (e) Cavity input -- One watt CW RF at the transmit frequency

2.4.9.1.1 The cavity modulated RF output signal at the 20 db directional coupler equals 0.65 V peak in amplitude; however, the modulated RF output signal of cavity number one is highly distorted and only slightly resembles the modulation applied to the cathode of the RF amplifier (TP75). From the directional coupler at the output of cavity one, the modulated RF signal is applied to cavity number two.

2.4.9.2 Number two cavity amplifies and shapes the distorted, modulated, RF signal into a form that resembles the applied modulation signal; however, a large amount of pedestal, due to the trapezoid modulation signal, still exists as noted by the detected waveform at the 20 db output directional coupler (TP76). The following voltages and signals (typical) are applied to number two cavity (RCA 7649) when the transmitter output waveform is conforming to the reference waveform:

- (a) Plate -- +2000 V
- (b) Screen Grid - +700 V
- (c) Control Grid -- Grounded
- (d) Cathode -- Modulation applied at +64 VDC level
- (e) Cavity input -- 5.8 watts peak power (6.122 watts average power)
- (f) Cavity modulated RF output signal at the 20 db output of the directional coupler = 2.9 V peak in amplitude

2.4.9.3 The following voltages and signals (typical) are applied to cavity number three (RCA 7649) when the transmitter output waveform is conforming to the reference waveform:

- (a) Plate - +2000 V
- (b) Screen grid - +700 V
- (c) Control grid -- Grounded
- (d) Cathode -- Modulation applied at +54 VDC level
- (e) Cavity input -- 46.3 watts peak power (0.975 watts average power)
- (f) Cavity modulated RF output signal -- at the 20 db output of the directional coupler = 4.8 volts peak in amplitude

2.4.9.3.1 Cavity number three amplifies and further shapes the modulated RF signal. The output signal of the cavity is applied to a 20 db directional coupler, where its wave shape closely resembles that of the modulation signal applied to the cathode of the RF amplifier (TP77). The output signal from the directional coupler is coupled through a DC voltage block to cavity number four.

2.4.9.4 Cavities one, two, and three used in this transmitter have the control grid internally connected to the grounded shell of the cavity. When the control grid must have a video control signal applied to it, as in the case of cavity four, it cannot be grounded. Therefore, to isolate the cavity shell from ground, DC voltage blocks were inserted.

2.4.9.5 Cavity number four amplifies the RF modulated signal and, when the feedback loop is connected to the grid of the final RF amplifier tube, shapes the RF output pulse to that of the reference pulse (TP78). If the feedback loop is not connected, the cavity output waveform is shaped, but contains a small pedestal on which the pulse pair is riding, and more pulse distortion appears (TP78 waveform "A") than with the feedback loop connected. The output signal of the fourth cavity is coupled through a DC voltage block to a 30 db directional coupler where the detected output waveform can be observed. The following voltages and signals (typical) are applied to cavity four (RCA 7649) when the transmitter output waveform is conforming to the reference waveform:

- (a) Plate - +2000 V
- (b) Screen grid - +700 V
- (c) Control Grid -- Spectral feedback error control signal at -60 VDC level
- (d) Cathode -- Modulation applied at +60 VDC level
- (e) Cavity input -- 410 watts peak power (8.64 watts average power)
- (f) Cavity modulated RF output signal -- at the 30 db output of the directional coupler = 1.65 V in amplitude; and
- (g) 1.1 KW peak power (23 watts average power) output to control duplexer.

#### 2.4.10 Difference Amplifier

A portion of the modulated RF output signal of the transmitter is sampled at the 30 db directional coupler, following the fourth cavity, is coupled through a 12 db pad to a 1N21ER diode detector, and is applied to the difference amplifier in the spectral feedback loop. The output waveforms of the reference generator are also applied to the difference amplifier. The difference amplifier, always comparing the detected input signal to the reference signal, develops an output error signal which is coupled to the video amplifier (TP80).

#### 2.4.11 Video Amplifier

The video amplifier amplifies the error signal to a value of approximately 15 volts in amplitude with no phase inversion (TP81).

#### 2.4.12 Output Video Amplifier

The error signal of the video amplifier is coupled to the output video amplifier (an 8 tube amplifier), where the error signal is further amplified. The error signal of the output video amplifier, approximately 200 V p/p, is applied to the control grid which is biased at -60 VDC (TP82).

#### 2.4.13 RF Output Signal

The output signal of the RF chain, now conforming to the reference waveform (see Figure 2.3), is coupled to the double slug tuner of the control duplexer. The output signal of the control duplexer is coupled to the antenna via the SA-420 coaxial switch, and transmitted as bearing, distance, and identity information.



## 2.5 Operation of the Solid-State Monitor (Reference Figure 2.4)

The following discussion describes the modular operation of the solid-state monitor, which was provided as part of the experimental solid-state TACAN ground station.

### 2.5.1 Percent Response - Reply Delay - Pulse Space Module

2.5.1.1 A repetition rate generator is provided in the percent response - reply delay - pulse space module for the purpose of developing a signal to interrogate the transponder. The generator provides pulses at a relatively random rate centered about approximately 30 pulses per second. The output signal of the repetition rate generator triggers a 12  $\mu$ sec multivibrator. The negative output pulse from the 12  $\mu$ sec multivibrator triggers a 50  $\mu$ sec delay multivibrator and provides one input to an OR circuit. The negative output pulse is ORed with the positive output pulse from the 12  $\mu$ sec multivibrator to create a pulse pair. The positive output pulse from the 12  $\mu$ sec multivibrator is also used to "set" a binary multivibrator. The output signal from the OR circuit, a pulse pair spaced 12  $\mu$ secs apart, drives a four  $\mu$ sec shaper multivibrator which produces a pulse pair spaced 12  $\mu$ secs apart (TP1). The output pulses from the four  $\mu$ sec multivibrator are fed to the ALC and modulator module.

2.5.1.2 The trailing edge of the output pulse from the 50  $\mu$ sec delay multivibrator triggers a switch which generates a pulse. The output pulse from the switch (TP6) provides one input signal for a two input AND gate. The other input signal to the AND gate is the composite line (TP5) from the one-half amplitude select module. If the monitor interrogate pulse pair interrogates the transponder, and the transponder responds to the monitor interrogation, the response signal will be present in the composite pulse train, which is seen at one input of the AND gate 50  $\mu$ secs after the pulse was generated by the 12  $\mu$ sec multivibrator. When the 50  $\mu$ sec delayed signal (TP6) and a response signal in the composite line (TP5) occur in coincidence with each other, the AND gate provides an output pulse. The output pulse from the AND gate is amplified and "resets" the binary multivibrator. The output pulse of the binary multivibrator drives a DC filter such that the DC voltage at the output of the filter is proportional to the repetition rate of the output pulses from the binary multivibrator. The repetition rate of the binary multivibrator output signal is in reality the number of transponder responses to the monitor interrogations.

2.5.1.3 The DC voltage from the filter drives the percent response meter and an emitter-follower. The output signal of the emitter-follower drives a voltage

controlled oscillator, which provides an output signal with a repetition rate that is proportional to the DC controlled voltage applied. The output signal from this oscillator is filtered and DC amplified to drive the monitor percent response - reply delay - pulse space alarm light.

## 2.5.2 ALC and Modulator Module

2.5.2.1 The pulse pair from the shaper multivibrator in the percent response module (TP1) is fed into a voltage controlled amplifier in the ALC and modulator module. The amplitude of the pulse pair is limited by a DC voltage, which is generated in this module. The amplitude controlled pulse pair is fed through a fixed gain amplifier. The output pulse pair from the fixed gain amplifier (TP2) is fed to the RF generator bias control circuitry.

2.5.2.2 A portion of the output signal from the RF generator is detected, and the detected signal is fed to an input in the ALC and modulator module, where it is amplified by two stages of amplification (TP3). After being amplified, the pulse pair is decoded into a single pulse with a width of approximately 12  $\mu$ secs. The decoded pulse is current amplified and filtered to the DC voltage level, which is used to limit the amplitude of the pulse pair from the percent response module. Hence, the amplitude of the RF generator output pulses is controlled by a feedback loop.

### 2.5.3 RF Generator

2.5.3.1 The RF generator is provided with a crystal controlled oscillator. The crystal is housed in an oven to stabilize the operating temperature, which insures greater stability of the oscillator frequency. The RF generated output frequency is such that, when multiplied 27 times, it will equal the transponder receiver frequency. The output signal from the crystal oscillator, which is CW, drives a buffer which prevents the effects of the following circuitry from altering the output frequency of the crystal oscillator, and amplifies the output signal.

2.5.3.2 The buffer output signal is coupled to a tripler where the signal frequency is multiplied by a factor of three. The tripler output signal is coupled to an amplifier, which is biased in the off condition until a pulse pair from the percent response module is received at the RF generator bias network. The pulse pair biases the amplifier and the following RF generator circuitry on, allowing a burst of RF signal to be amplified. The amplifier output signal is coupled to two series connected triplers which, when biased on by the pulse pair from the percent response module, multiplies the input signal frequency by a factor of nine. Following this increase in frequency, the signal is amplified through a pulse

pair controlled bias network. The amplifier output RF pulse pair signal is fed to two places. A portion of the output signal is sampled, detected, and coupled to an input of the ALC module, as described in the discussion of the ALC and modulator module. The majority of the RF generator output signal is coupled to an RF attenuator for interrogation level control purposes. The attenuated signal is coupled via a 20 db directional coupler into the SA-420 Switch Test Adapter to the transponder duplexer, and then coupled into the receiver. If the interrogate signal is accepted by the transponder, 50  $\mu$ secs after the signal was received at the duplexer, a response pulse from the transmitter will be provided at the duplexer.

#### 2.5.4 One-Half Amplitude Select Module

2.5.4.1 The composite signal train (squitter, interrogate, bearing, and identity pulses) from the duplexer is coupled to the SA-420 Switch Test Adapter, where the signal is sampled. The sampled portion of the composite signal is coupled to an RF attenuator, which is used to control the amplitude of the composite signal. The attenuated composite signal is sent to a diode detector, the output of which is a video envelope of the RF pulse bursts which constitute the composite line from the duplexer (TP4). The output signal from the detector is fed to the one-half

amplitude select module as an input signal. This signal is voltage and current amplified, and inverted by five stages of amplification. The amplified signal is used as an input signal for the peak power and identity module (TP12). This signal is also used to trigger the pedestal forming circuitry of the one-half amplitude select module. The pedestal generating circuitry determines the one-half amplitude trigger point, which is maintained throughout the monitor. The pedestal generator produces a pulse at approximately the one-half amplitude of the second pulse in the pulse pair, if the circuitry has been properly aligned. After the pulse pair has been developed by the pedestal circuitry, the pedestal voltage is discharged by a reset pulse from the marker burst module (TP8). The pulse pair is amplified and shaped through an amplifier and a blocking oscillator. The blocking oscillator output pulse pair sets and resets a 12  $\mu$ sec bi-stable multivibrator, which is used to decode the pulse pair. The trailing edge of the 12  $\mu$ sec bi-stable multivibrator triggers a tolerance gate multivibrator, which is used to generate a "variable width pulse", with its leading edge occurring at the one-half amplitude point of the second pulse of the composite line pulse pair (TP5). The output signal, a decoded composite line signal, is supplied to the percent response module, the marker burst module, and the squitter rate module.

## 2.5.5 Marker Burst Module

2.5.5.1 The composite line signal from the one-half amplitude select module (TP7), after being current amplified, drives a multi-tap delay line and provides an input signal for a marker burst selecting AND gate. The output signal from the first tap in the delay line is fed back to the one-half amplitude select module to "dump" the pedestal voltage after the pulse pair has been developed by the pedestal circuitry (TP8 and TP8A). The second tap on the delay line provides an output signal for the decoded composite line signal, which is delayed by 24  $\mu$ secs. The third delay line tap provides an output signal for the decoded composite line signal, which is delayed by 30  $\mu$ secs. The output signals from the second and third delay line taps are ORed together. The output signal of the OR gate provides the other input to the marker burst selecting AND gate (TP9 and TP9A), i.e., any time one pulse in the decoded composite signal follows another by 24 or 30  $\mu$ secs, coincidence occurs at the AND gate and the AND gate delivers a pulse; hence, when a burst of six auxiliary pulses occur in the decoded composite signal, the AND gate will produce five output pulses which are in coincidence with the last five auxiliary pulses in the decoded composite signal (TP7 and TP9). Similarly, 12 north pulses in the decoded composite signal will cause 11 pulses to occur at the output of the AND gate (TP7A and TP9A).



2.5.5.2 The signal from the AND gate, after being amplified, triggers a five-to-one analog counter, i.e., if five pulses occur in a fixed time, an output pulse is generated (TP10 and TP10A). Since each north and auxiliary reference burst occurs within the fixed time, a burst of five auxiliary pulses will cause an output pulse from the analog counter, and a burst of 11 pulses will cause two output pulses with the potential proportional to that of the trigger pulse remaining in the analog counter; however, the pulse voltage amplitude remaining in the counter decays to the steady state potential prior to the occurrence of the next reference burst.

2.5.5.3 The output pulses from the analog counter are amplified prior to triggering a 5.5 millisecond monostable multivibrator (TP11 and TP11A). Since the two pulses from each north reference burst occur within 150  $\mu$ secs of each other (much less than 5.5 milliseconds), the second pulse does not alter the operation of the multivibrator; hence, each reference burst creates one trigger for the 5.5 millisecond multivibrator. The output signal from the multivibrator is converted to an average DC voltage, which is amplified and used to energize the marker burst alarm light.

#### 2.5.6 Squitter Rate Module

2.5.6.1 Since the north and auxiliary reference bursts have been delayed (in the transponder) with respect to their associated north and auxiliary trigger pulses, the north

and auxiliary trigger pulses received at the squitter module must be delayed in order to occur in sync with north and auxiliary reference bursts located in the decoded composite signal.

2.5.6.2 The north trigger input pulse (TP14) is delayed 74  $\mu$ secs with a monostable multivibrator. The trailing edge of the output signal from the multivibrator (TP15), after being amplified, triggers an inhibit gate. The inhibit output signal is provided as an input signal to a NOR gate (TP17). The auxiliary trigger input signal (TP14A) is handled in the same manner (TP15A), except that the inhibit gate circuitry, associated with the auxiliary reference pulse, provides an inhibit signal of shorter duration than the north circuit inhibit gate (TP16). The auxiliary inhibit output signal provides the other input to the NOR gate. The output of the NOR gate is provided as one input signal to an AND gate. The other AND gate input signal is the decoded composite line pulses from the one-half amplitude select module (TP5).

2.5.6.3 The signal from the NOR gate allows all pulses in the decoded composite line, except for the reference bursts, to pass through the AND gate. The AND gate output signal is amplified and pulse stretched. The output signal from the pulse stretcher is provided as an input signal to the peak power and identity module (TP18) and to the squitter counter circuitry (which was not completed when

the solid-state monitor was made available as part of this contract).

#### 2.5.7 Peak Power and Identity Module

The peak power and identity module performs two unrelated functions which will be discussed separately.

##### 2.5.7.1 Peak Power Function

The composite signal in the one-half amplitude select module, as was indicated in Paragraph 2.5.4, triggers the pedestal forming circuitry in the one-half amplitude select module, as well as provides two input signals to the peak power circuitry in the peak power and identity module (TP12). One input signal is current amplified and voltage summed with the trigger waveform of a free-running unijunction oscillator (peak detector). The output frequency of the free-running unijunction oscillator is increased as the voltage amplitude of the composite signal pulses increases; however, an alteration in the repetition rate of the pulses in the composite signal could also alter the trigger rate of the free-running unijunction oscillator. The unijunction oscillator output signal is rectified to a DC voltage signal. The amplitude of the DC voltage is proportional to the repetition rate of the pulses from the unijunction oscillator. The DC signal, after being current amplified, drives a switch which controls the ignition or extinction of the peak power light. The other input signal from the composite line is current amplified, rectified, and current amplified. The amplified signal (TP13) drives the peak power meter.

#### 2.5.7.2 Identity Function

The decoded composite line pulses (TP19), minus the reference pulses, from the squitter rate module are current amplified in the peak power and identity module. The output signal from the current amplifier drives a parallel resonant tank circuit, which is resonant to 1350 cps. The output signal of the parallel resonant tank circuit is current amplified and rectified such that the positive portions of the signal are passed. The rectified signal first triggers another resonant circuit and then is current amplified. The output signal from the current amplifier is used to drive a set of head phones for an aural output (TP20).

#### 2.5.8 Antenna Speed Module

2.5.8.1 The antenna speed module receives two input signals which are acted on to provide an alarm for deviations in antenna speed. One input, the 1350 cps signal, is supposed to be supplied by the tone wheel from an antenna; however, a 1350 cps audio oscillator was used to simulate the signal which is normally generated by the antenna tone wheel, since an AN/URN-3 antenna was used for the experimental work involving this monitor. The 1350 cps input signal (TP21) saturates the input amplifiers to make the slopes of the signal steep for better trigger stability. The signal, after being saturated, triggers a 7.4  $\mu$ sec multivibrator, which generates pulses 7.4  $\mu$ secs in width. One output signal of the 7.4  $\mu$ sec multivibrator acts as an input signal

to an AND gate (TP26), which will be discussed below. The other 7.4  $\mu$ sec multivibrator output signal (TP22), after being differentiated, provides a negative set pulse, through an OR circuit, to trigger a set-reset (S-R) type multivibrator. The other input signal at the OR gate is a positive pulse (TP23), which is generated by circuitry which alters the north trigger input supplied through the squitter rate module; hence, each north pulse sets the S-R multivibrator and the first 1350 cps tone pulse, which occurs after the north pulse, resets the S-R multivibrator. The S-R multivibrator output signal is differentiated by a differentiating network. The differentiated signal triggers a 744  $\mu$ sec multivibrator. The trailing edge of the 744  $\mu$ sec multivibrator output pulse (TP24) triggers a pulse shaping inverter amplifier (TP25) and is ANDed with the output signal from the 7.4  $\mu$ sec multivibrator (TP26) mentioned above; hence, the first 1350 cps pulse following the north trigger is delayed 744  $\mu$ secs (the period of 1350 cps signal), and ANDed with the second 1350 cps pulse following the north trigger. Coincidence, therefore, occurs at the AND gate if the antenna pulser plate is generating a signal which is occurring at 1350 cps rate.

2.5.8.2 The output signal from the AND gate triggers a blocking oscillator where it is shaped and amplified. The blocking oscillator output signal, after being pulse stretched, is filtered into an average DC voltage. The

DC voltage controls a switch, which in turn, controls the antenna speed monitor light.

2.5.9 Percent Modulation Module

2.5.9.1 The monitor antenna picks up the radiated signal from the TACAN antenna. The monitor antenna signal is then coupled through an RF attenuator, for amplitude control, to a detector. The detector output signal is coupled to the percent modulation module as the input signal (TP27). The input signal is voltage and current amplified before triggering a peak riding detector. The output signal from the peak riding detector (TP28) is current amplified prior to driving a 135 cps filter. The 135 cps output signal (TP29) from the filter is amplified, rectified, and filtered to an average DC signal. The DC signal, after being amplified, controls the switch, which in turn, controls the percent modulation alarm light. This circuit, in reality, monitors the amplitude of the 135 cps component of the TACAN radiated signal, not percent modulation.

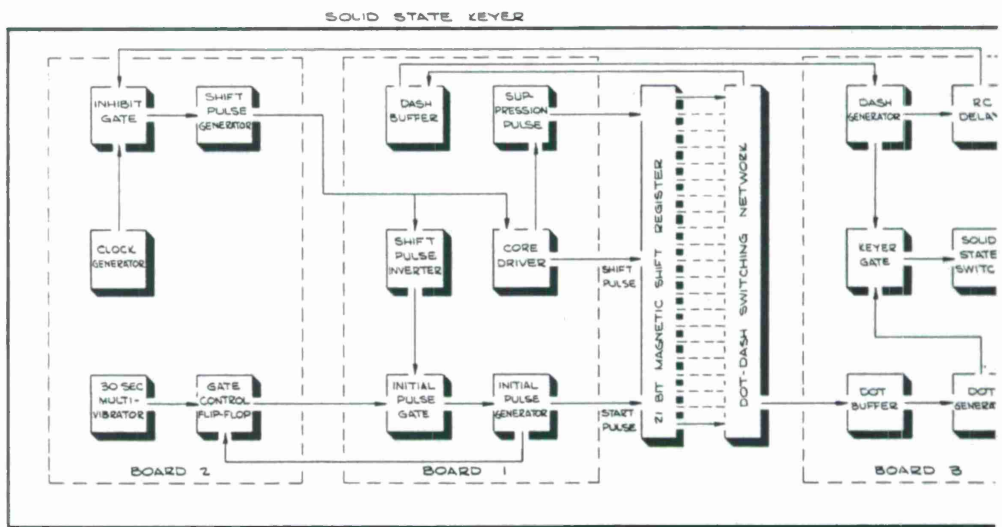
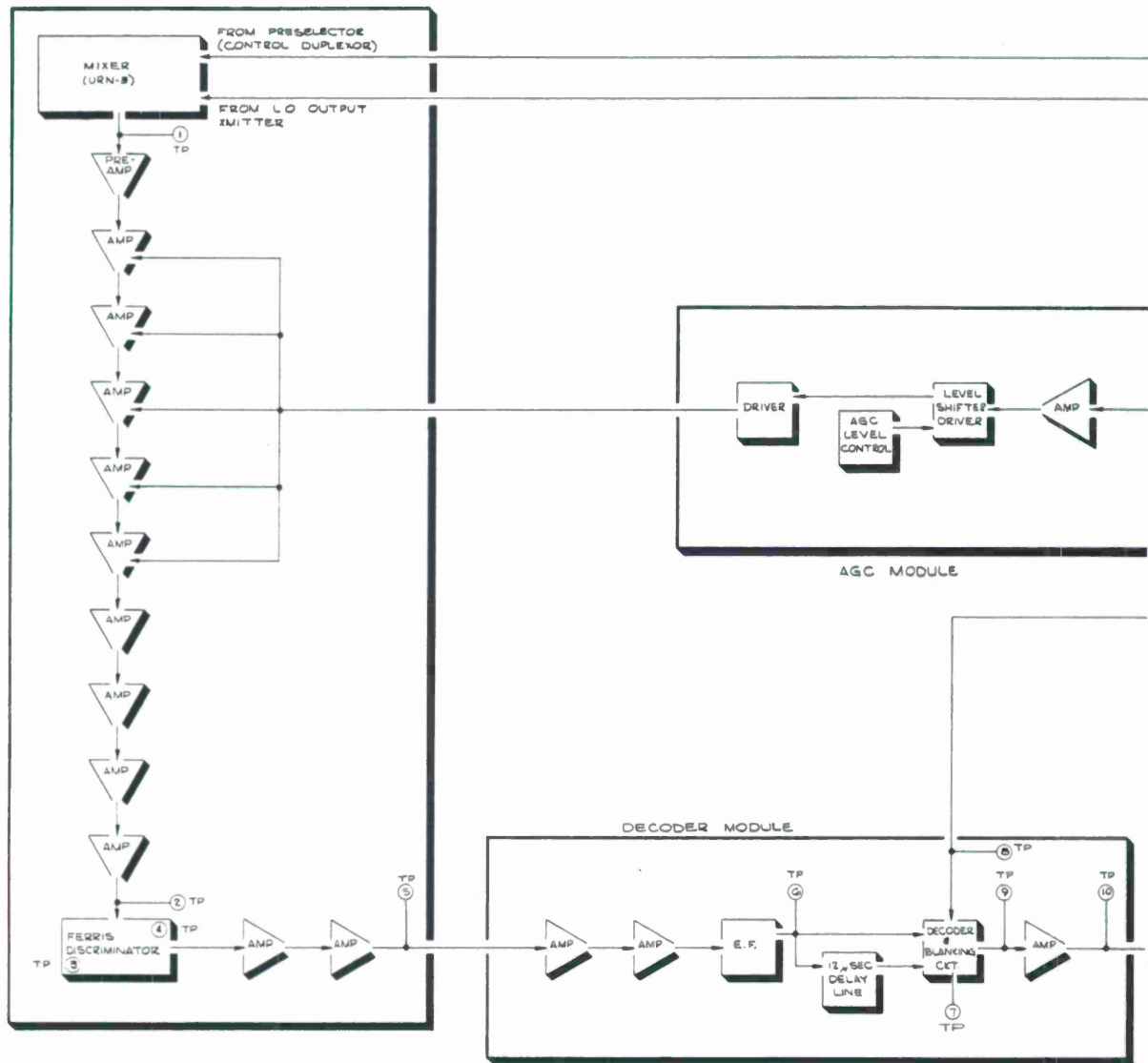



ROSSC  
TRIG A  
T OF

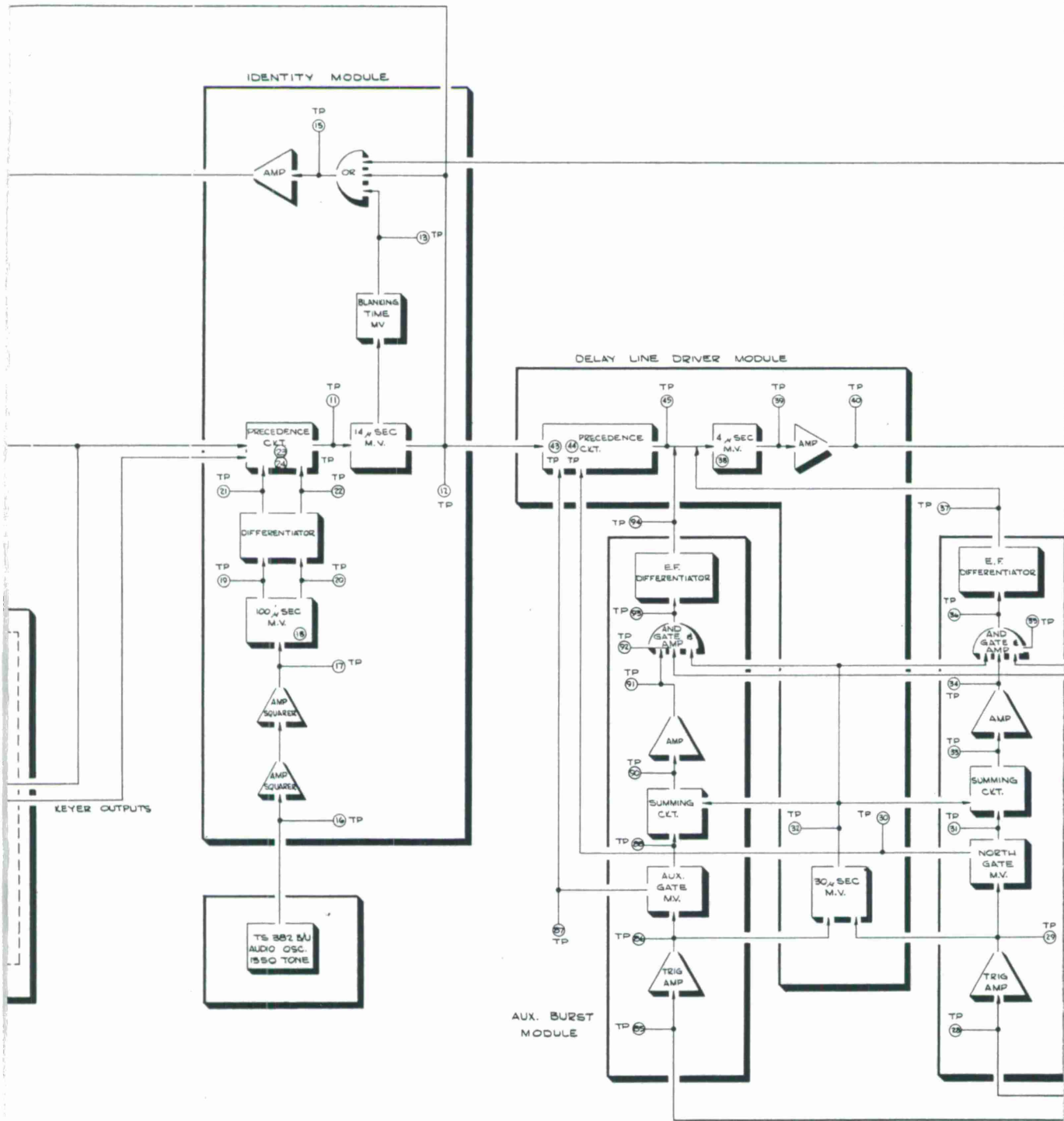

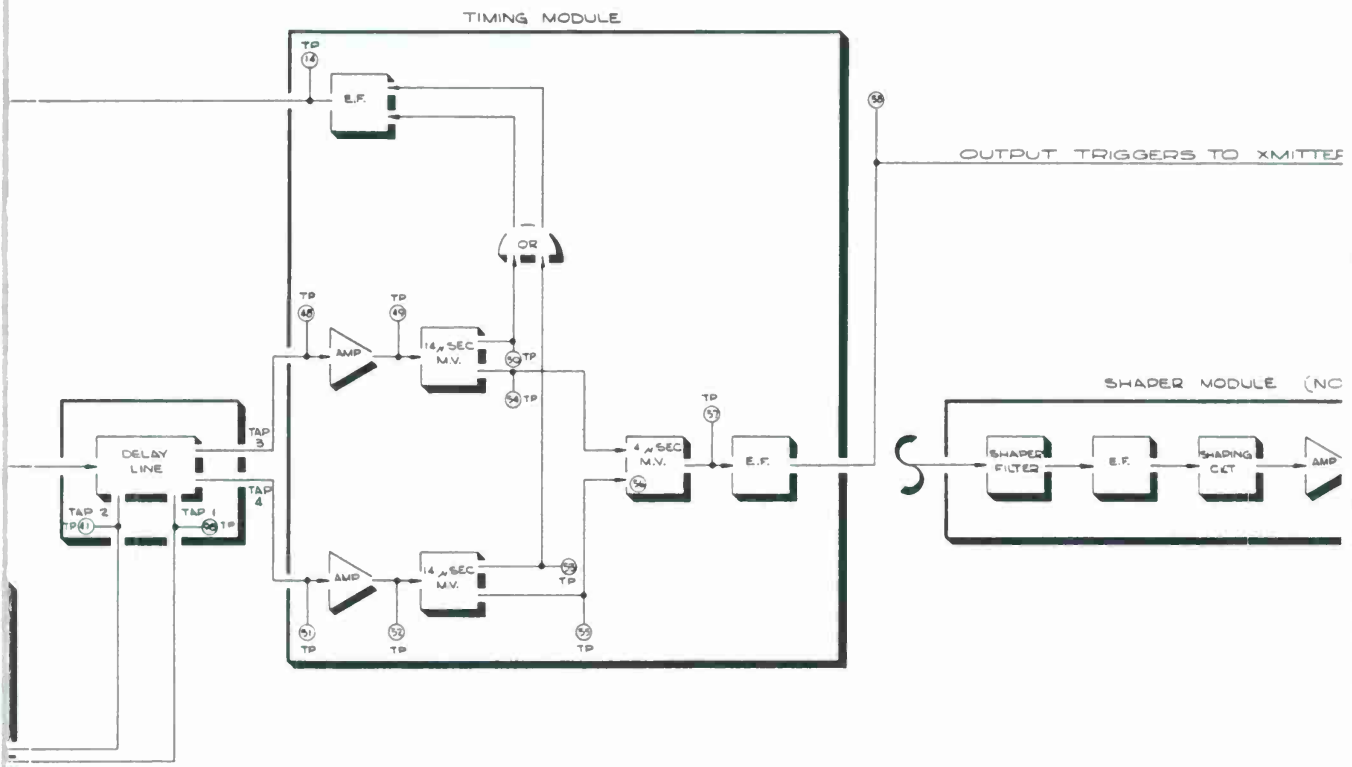

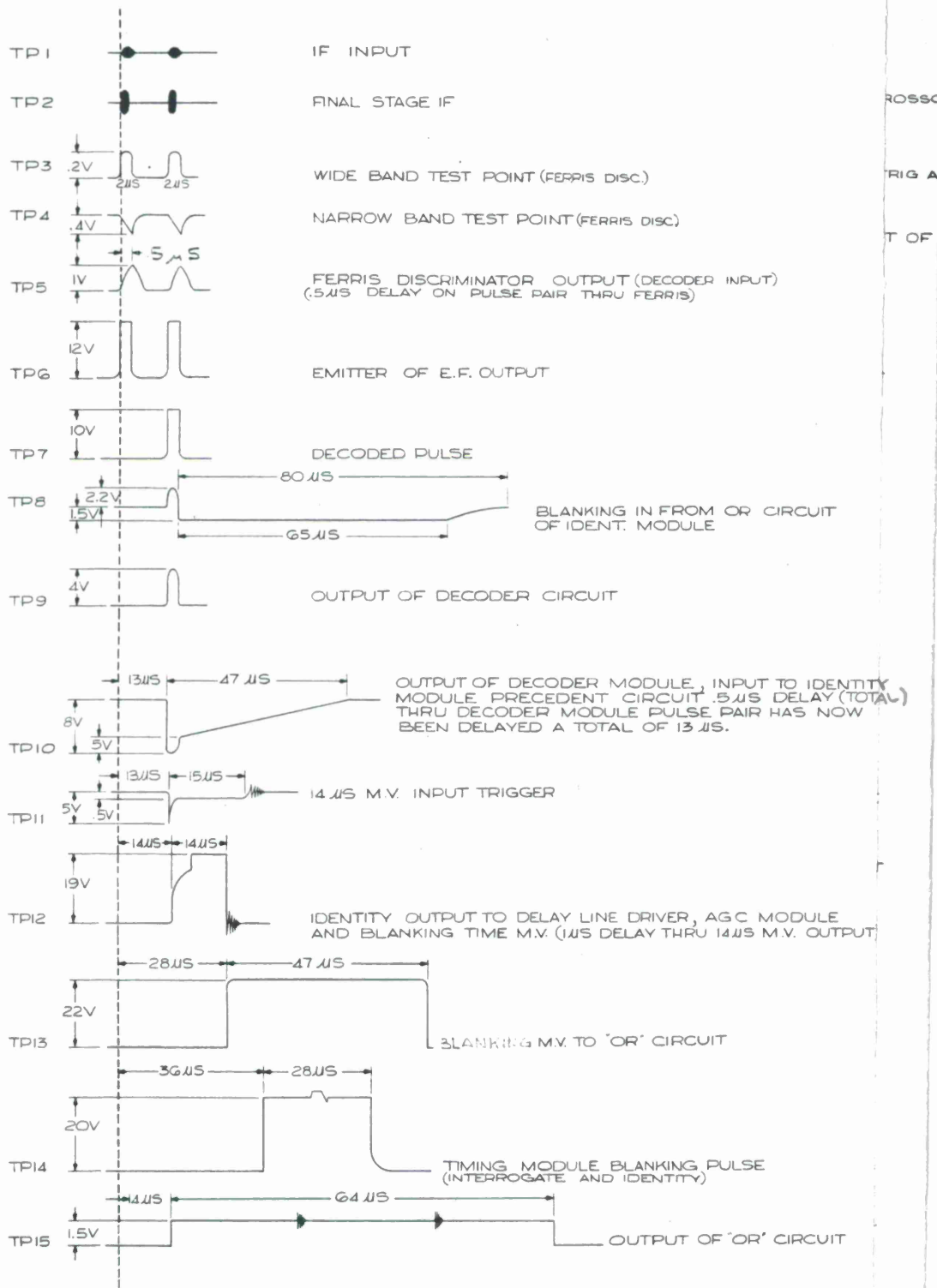

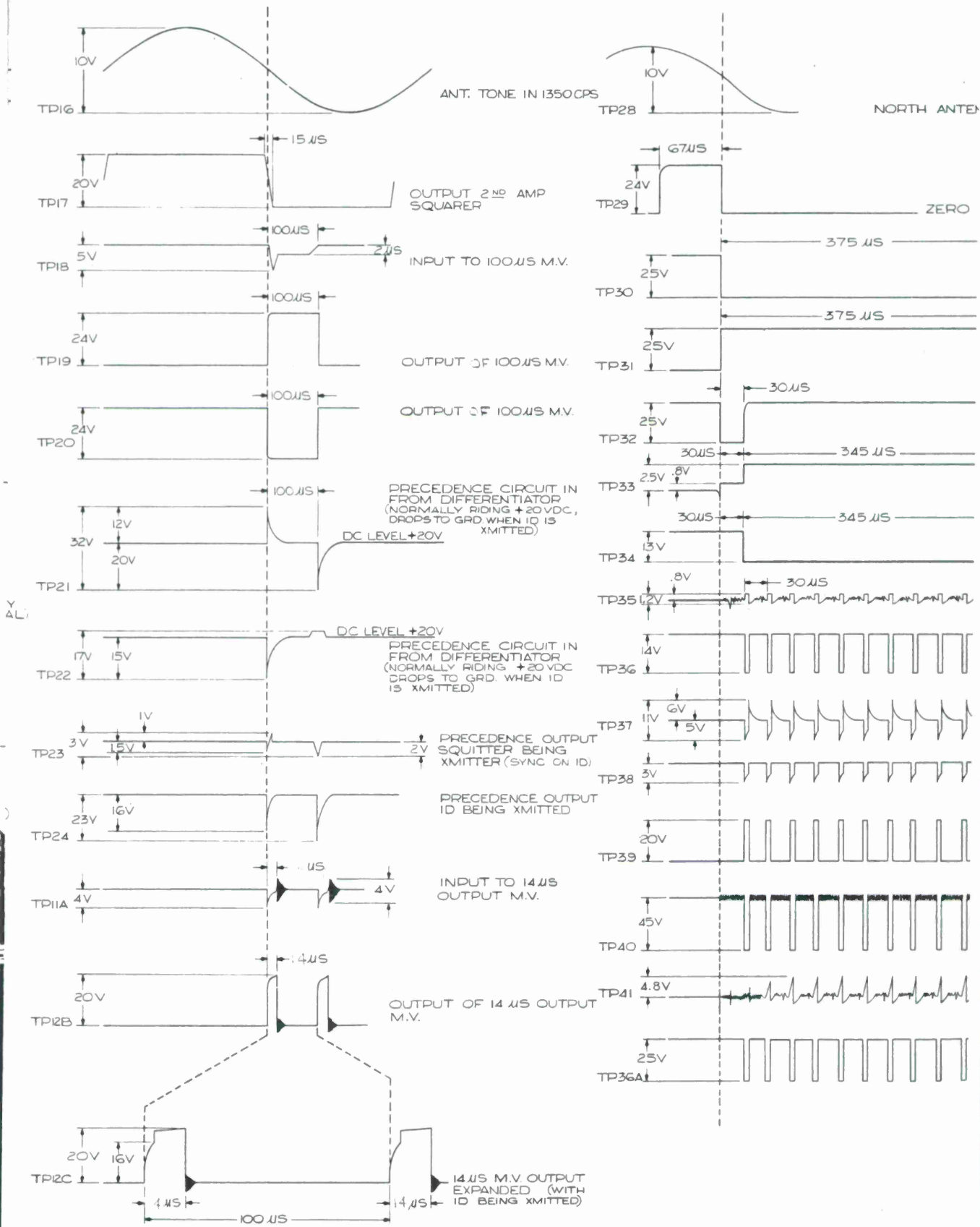

NA TRIGGER (EXPANDED SHOWING CROSSOVER)

AUX. ANTENNA TRIGGER (EXPANDED SHOWING CROSSOVER)

CROSSOVER TRIG OUT OF AMPLIFIER

NORTH GATE TO PRECEDENCE CIRCUIT OF DELAY LINE DRIVER

NORTH GATE TO SUMMING CIRCUIT

DELAY LINE DRIVER 30 μS M.V. OUTPUT

SUMMING CIRCUIT OUTPUT

AMP. OUTPUT

AND CIRCUIT PULSES

AND CIRCUIT PULSES AFTER AMPLIFICATION

NORTH OUTPUT TRIGS TO DELAY LINE DRIVER 4 μS M.V.

NORTH OUTPUT TRIG AT 4 μS M.V. INPUT

4 μS M.V. OUTPUT

OUTPUT DELAY LINE DRIVER TO DELAY LINE

DELAY LINE PULSES IN

AND CIRCUIT OUTPUT

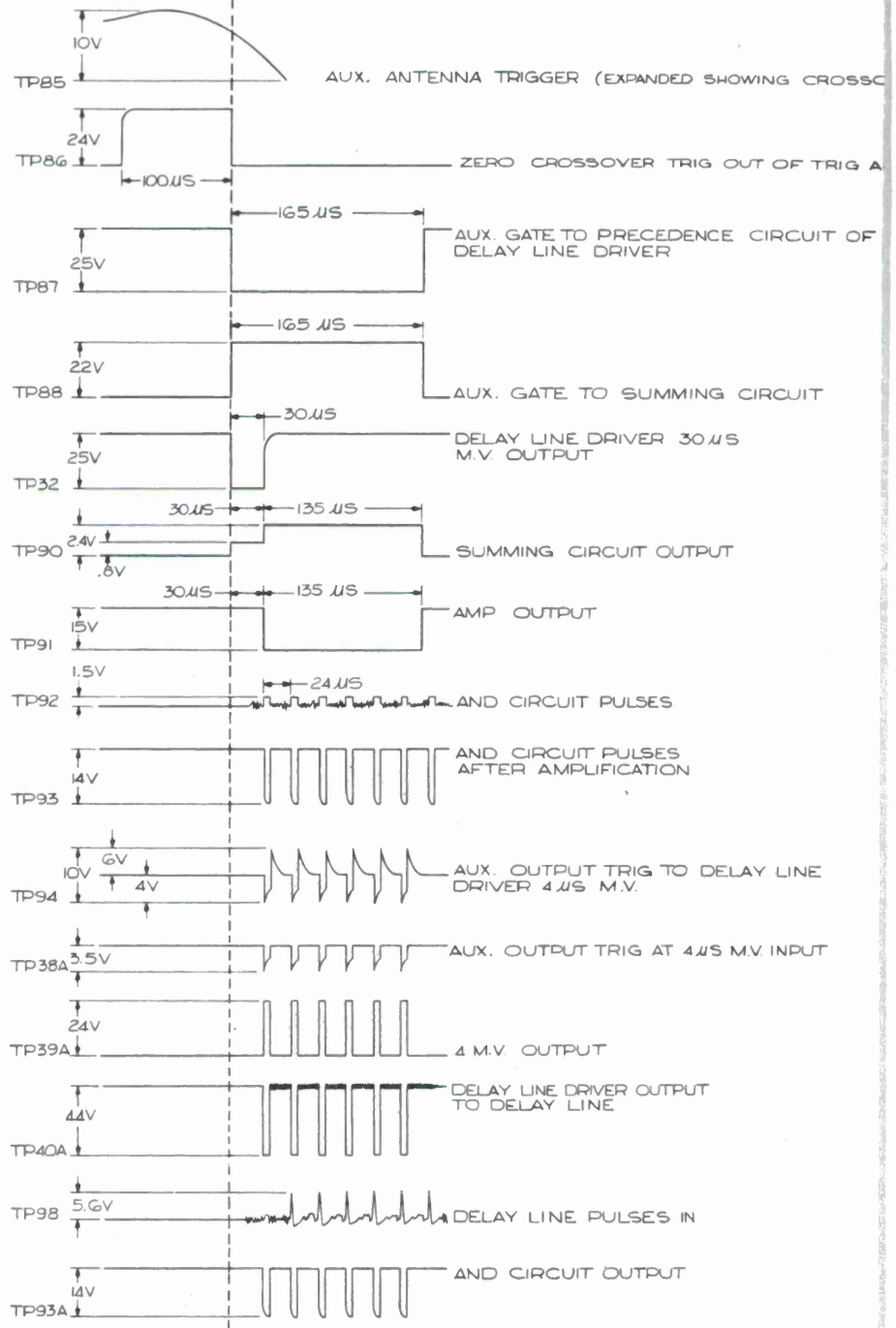

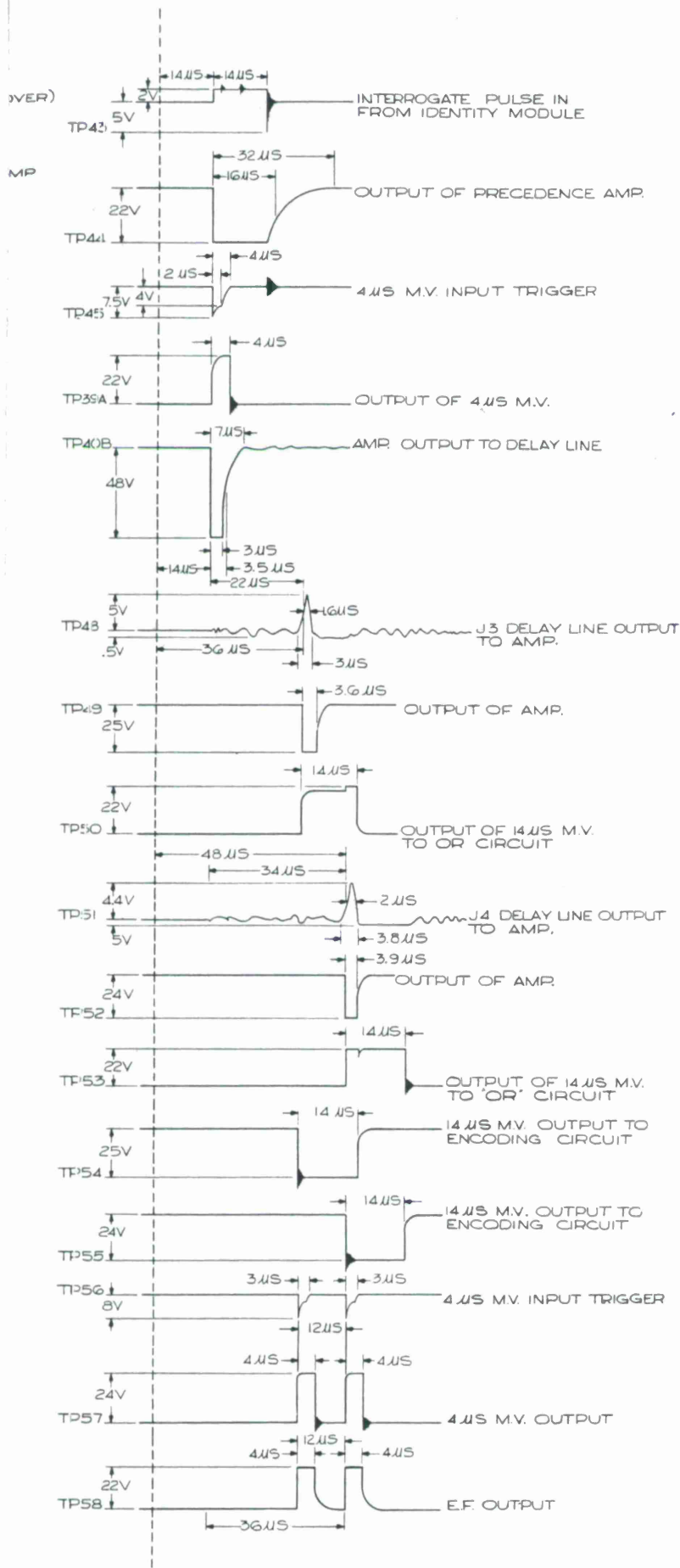

<b>MONTEK INC.</b> SALT LAKE CITY, UTAH	
A DIVISION OF MODEL ENGINEERING & MANUFACTURING CORP. HUNTINGTON, INDIANA	
SOLID STATE TACAN RECEIVER - CODER	
MGR. NAV-AIDS DEPT.	DEAN S. THORNBERG
TACAN TEAM CHIEF	THIEL J. GOMM
TACAN SYS. TECH.	HAROLD J. KENNER
DRAWN BY R. WARD	NAV-AIDS DEPT.
DATE ISSUED	DRAWING NO. 24-234-2

FIGURE 2.1



INTERROGATE PULSE — PRESELECTOR OUTPUT TO MIXER INPUT

L.O. OUTPUT TO MIXER L.O. INPUT

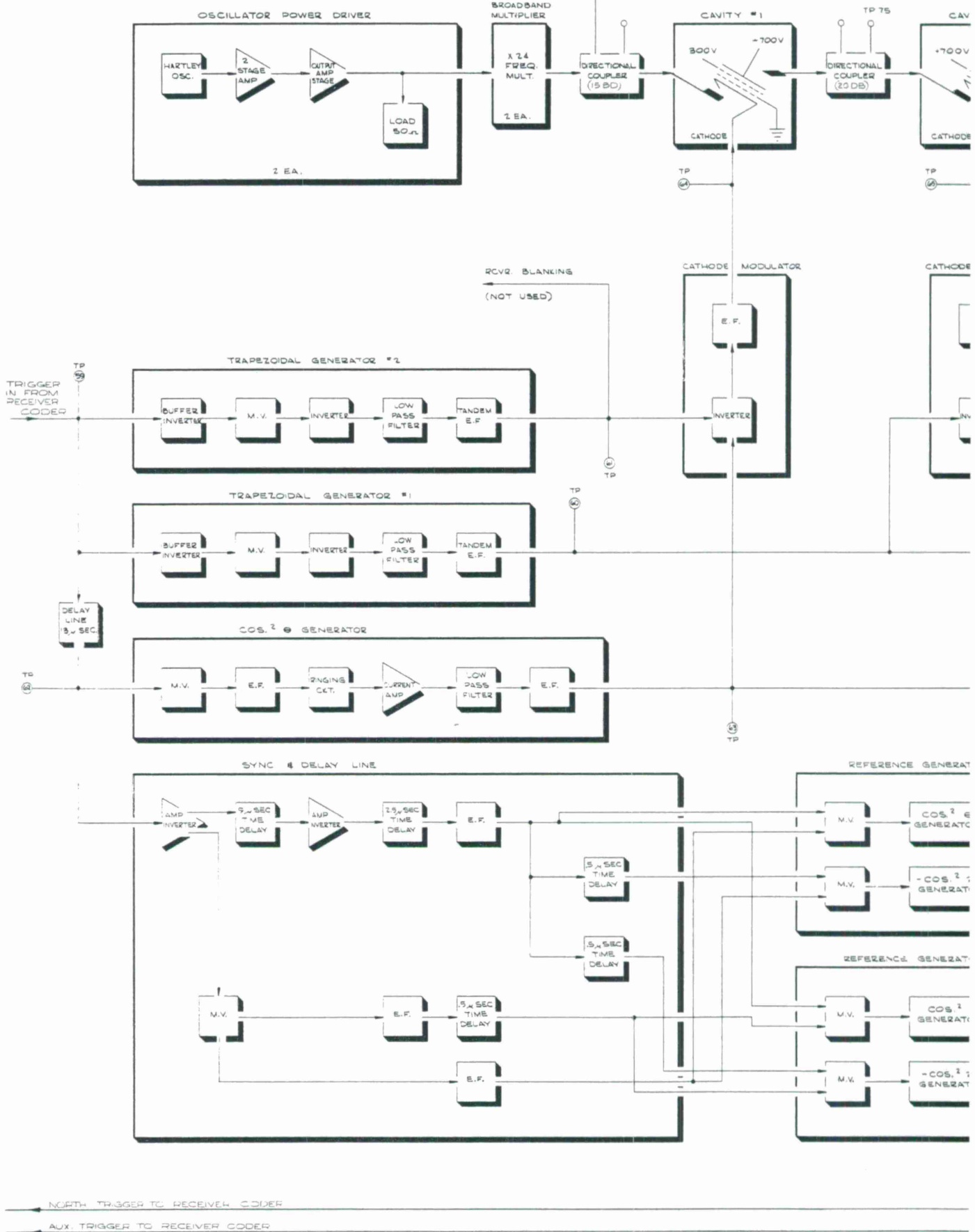



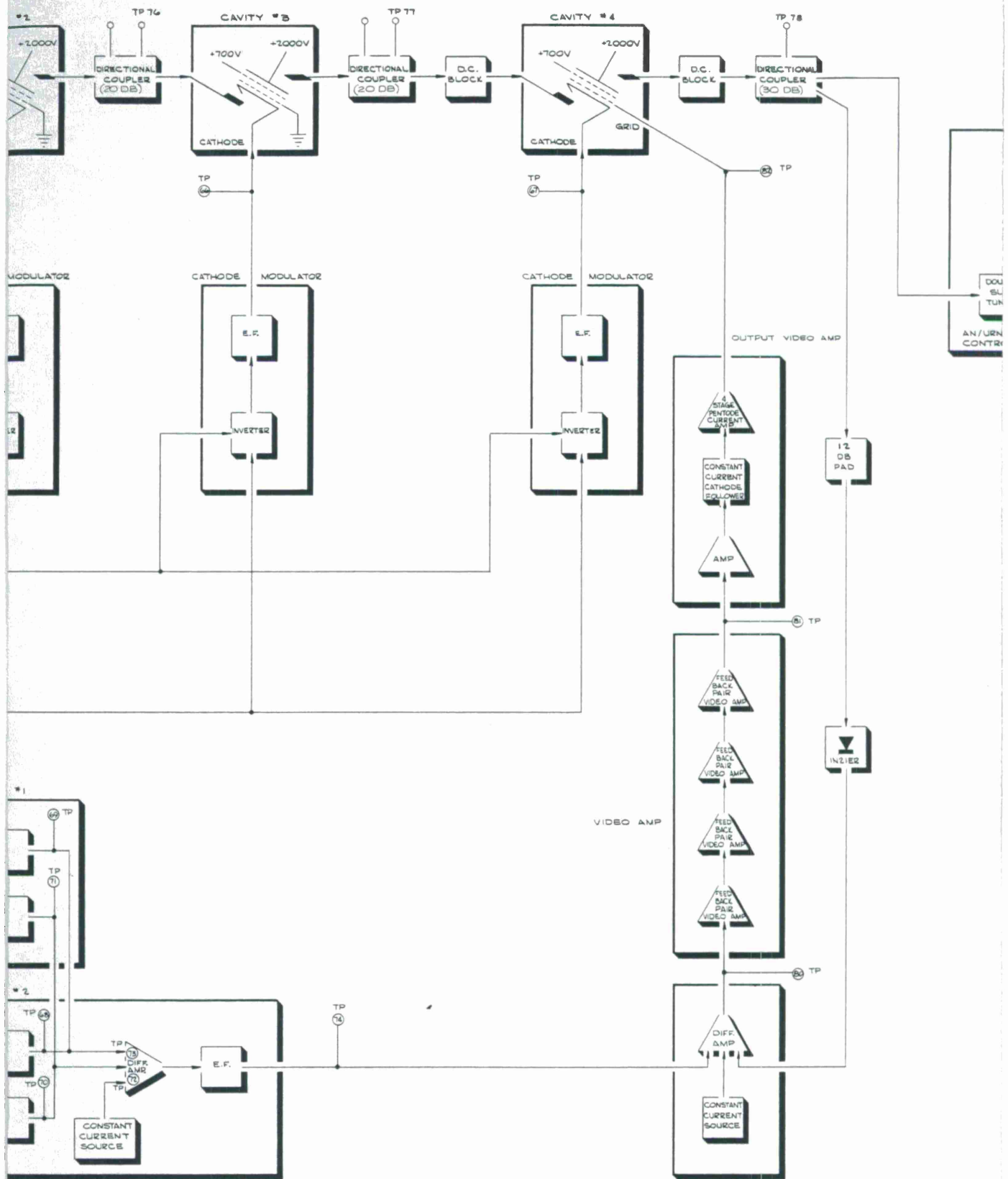

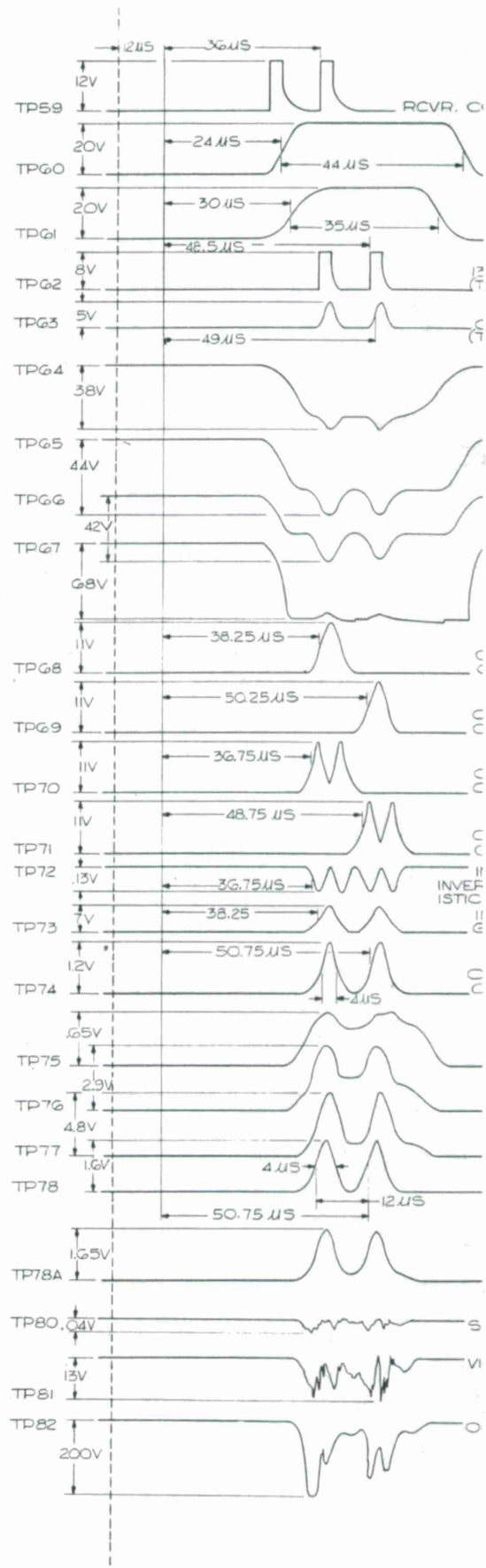
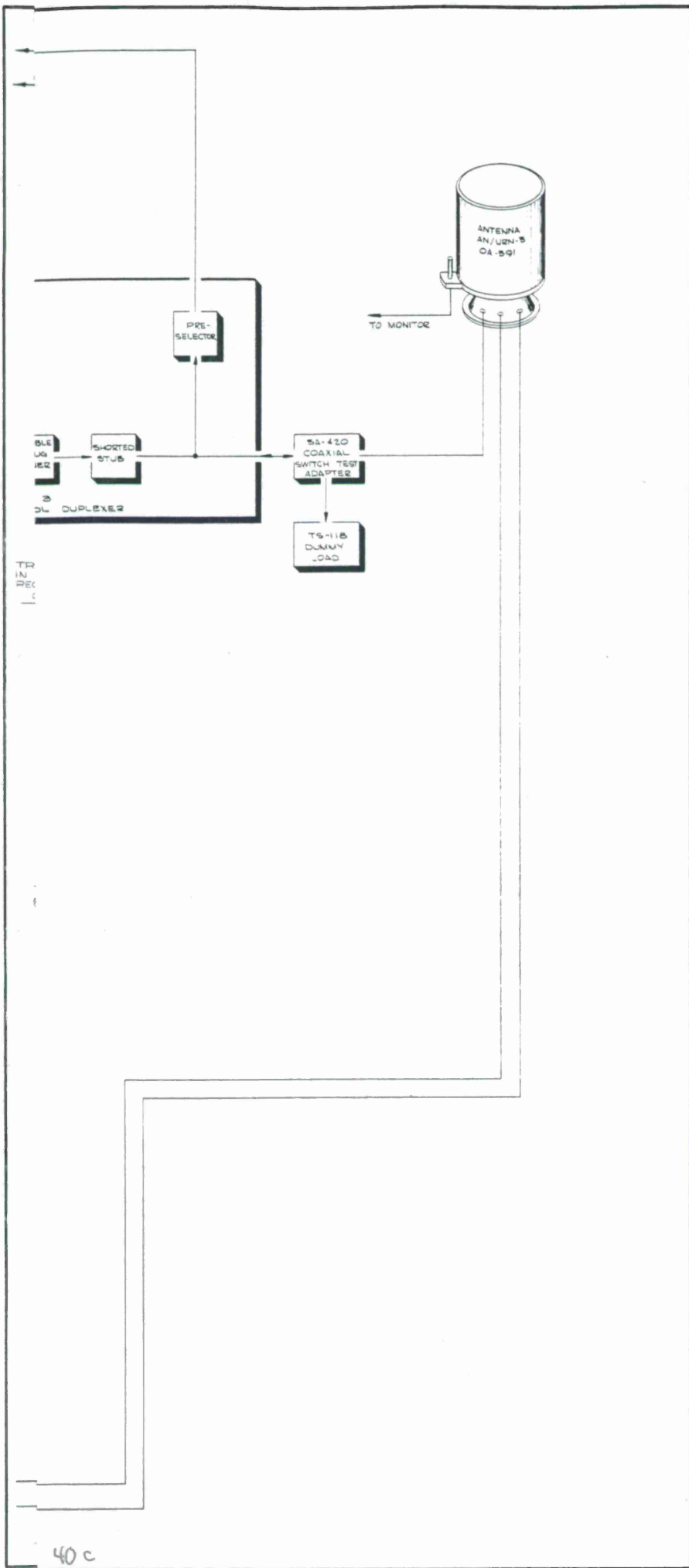

SE PAIR OUTPUT

PEZOIDAL GEN.  
JT (TO MODS. 2,3,4)

PEZOIDAL GEN.  
JT (TO MOD. 1)  
LINE OUTPUT  
(EN, SYNC & DELAY LINE)

QUARED GEN OUTPUT  
(3,4)

UT CATHODE MODULATOR \* 1  
(VEL +36V)

UT CATHODE MOD. \* 2  
(VEL +64V)

JT CATHODE MOD. \* 3  
(VEL +54V)

JT CATHODE MOD. \* 4  
(VEL +60V)

F COS<sup>2</sup> θ CIRCUIT  
EN II

F COS<sup>2</sup> θ CIRCUIT  
EN I

-COS<sup>2</sup> 2θ CIRCUIT  
EN II

F -COS<sup>2</sup> 2θ CIRCUIT  
EN I

DIFF. AMP. OF REF. GEN II (FROM -COS<sup>2</sup> 2θ CKT.)  
DIFF. AMP. TO SHOW ADDITION CHARACTER-  
AMP.  
DIFF. AMP. OF REF.  
COS<sup>2</sup> θ CKT.)

DIFF. AMP.  
GENERATOR II

JT CAVITY \* 1

UT CAVITY \* 2

JT CAVITY \* 3

JT CAVITY \* 4 (FEED BACK LOOP CLOSED)

UT CAVITY \* 4 (FEED BACK LOOP OPEN)

FEEDBACK LOOP DIFF. AMP. OUTPUT  
OUTPUT

DEO AMP. OUTPUT

<b>MONTEK INC.</b> SALT LAKE CITY, UTAH A DIVISION OF MODEL ENGINEERING & MANUFACTURING CORP. HUNTINGTON, INDIANA	
SOLID STATE TACAN TRANSMITTER	
MGR. NAV-AIDS DEPT.	DEAN S. THORNBERG
TACAN TEAM CHIEF	THIEL J. GOMM
TACAN SYS. ENGR	R. MAX STEADMAN
DRAWN BY R. WARD	NAV-AIDS DEPT.
DATE ISSUED 28 AUG 1964	DRAWING NO. 64-224-3

FIGURE 2.2

TRANSMITTER RF OUTPUT PULSE PAIR  
CONFORMING TO THE REFERENCE PULSE PAIR

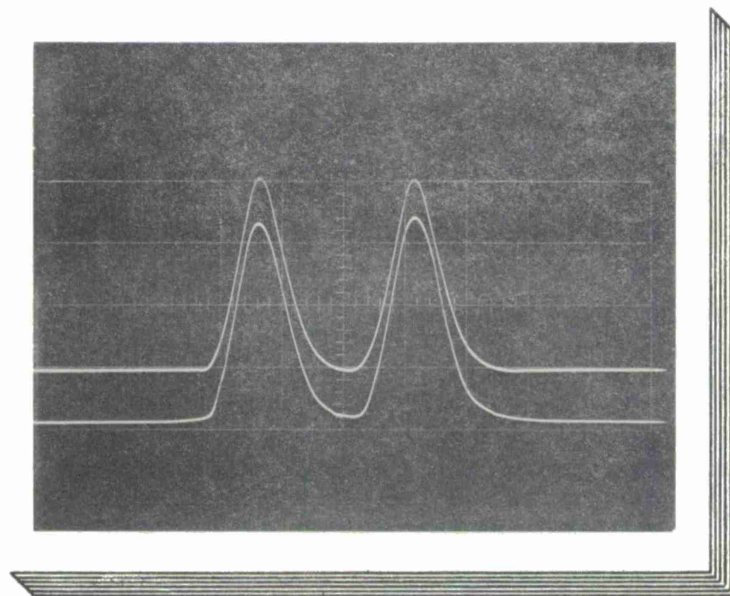

TOP WAVEFORM -- REFERENCE GENERATOR OUTPUT

BOTTOM WAVEFORM -- 4th CAVITY OUTPUT

FIGURE 2.3

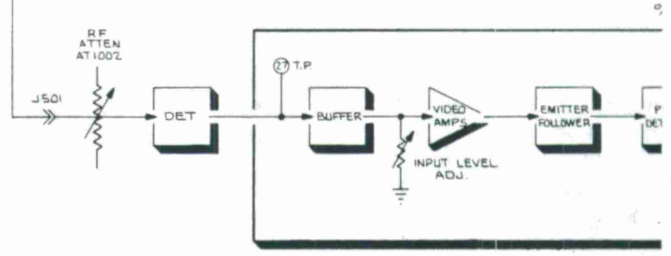
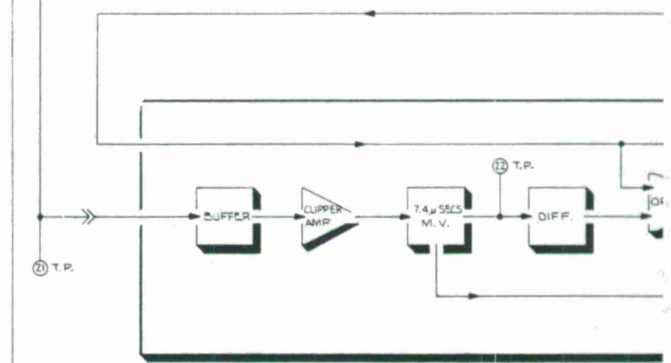
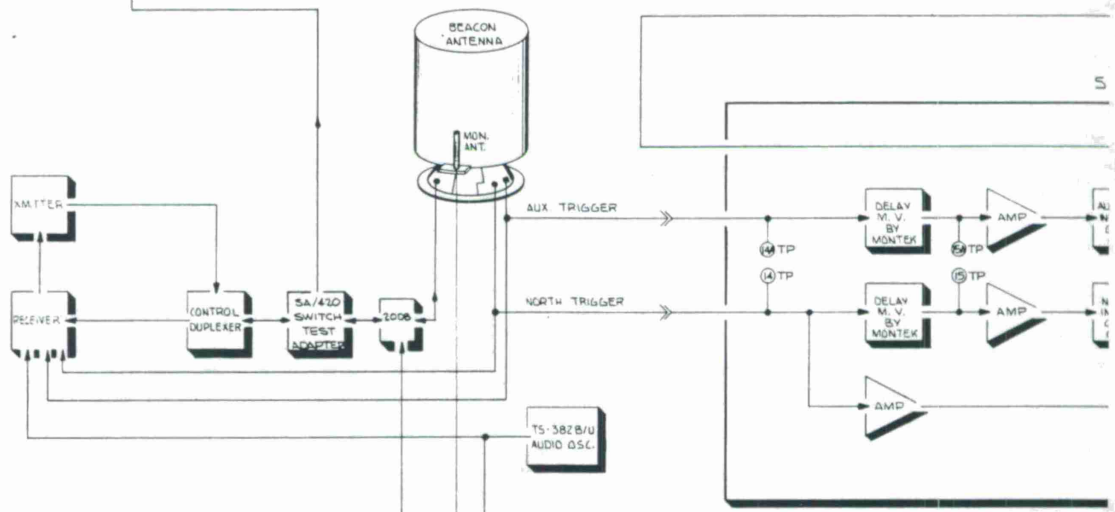
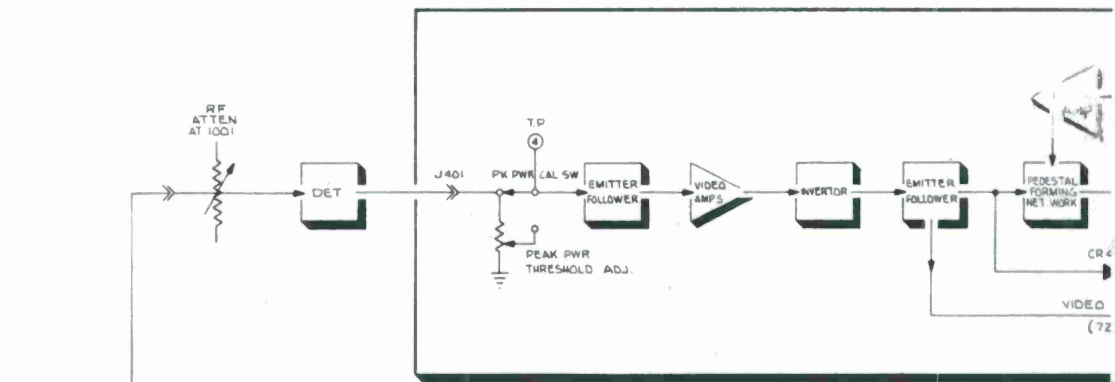

LECT MODULE

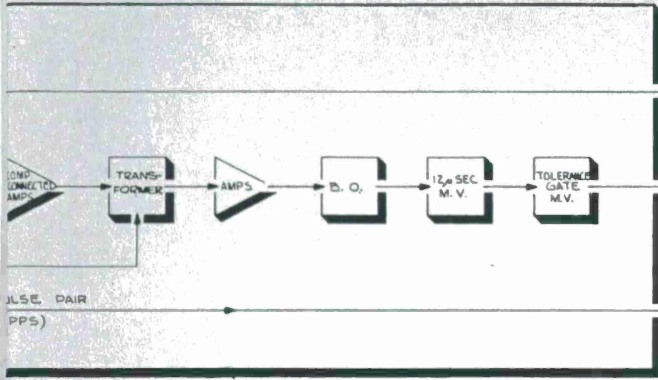

ITTER RATE MODULE

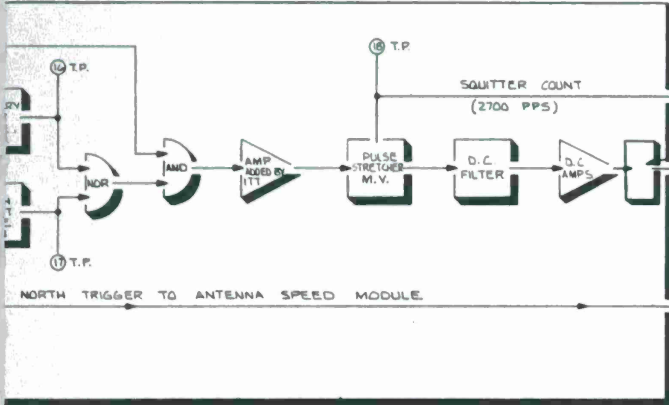

ANTENNA SPEED MODULE

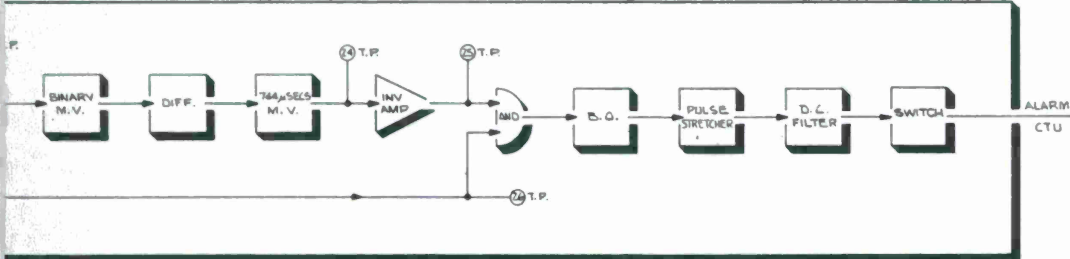

MODULATION MODULE

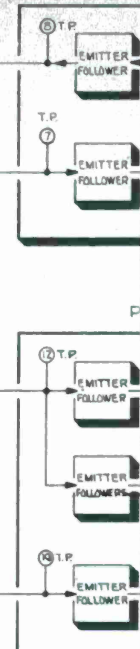
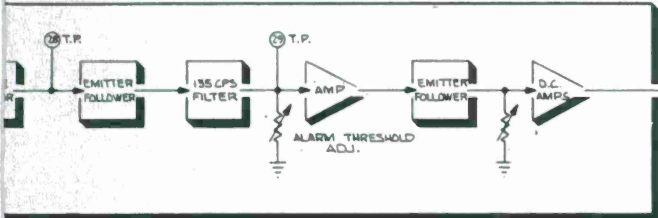

RF ATTEN AT 1003



MARKER BURST MODULE

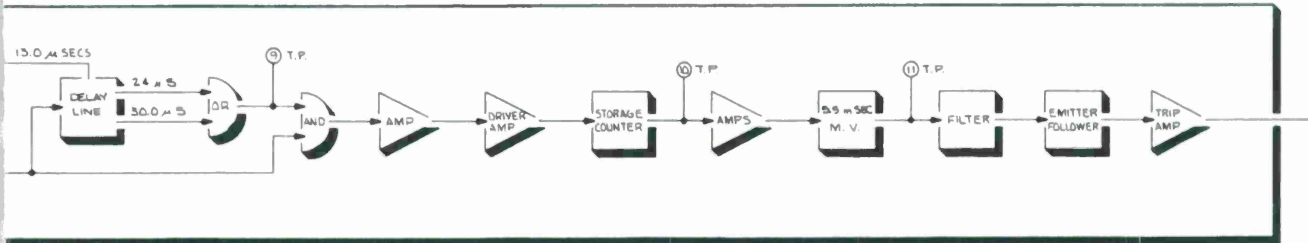

PEAK POWER AND IDENTITY MODULE

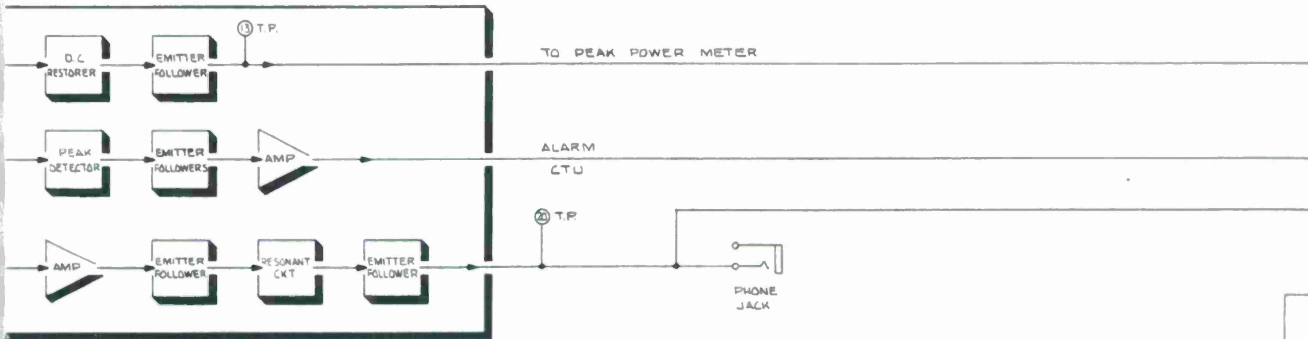

% RESPONSE - REPLY DELAY - PULSE SPACE MODULE

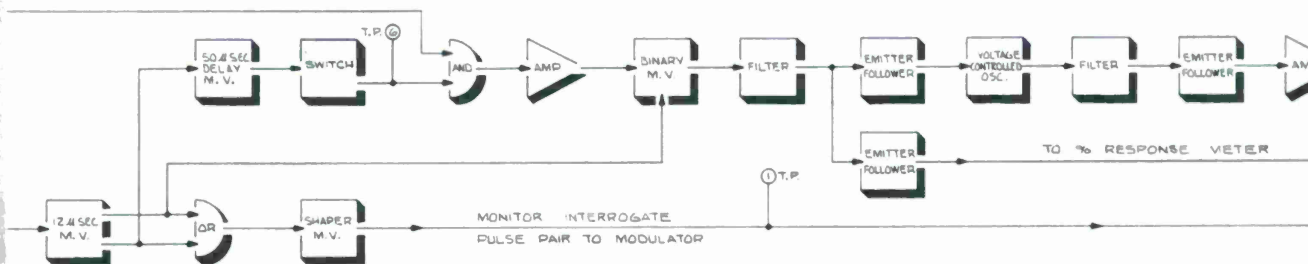

ALC AND MODULATOR MODULE

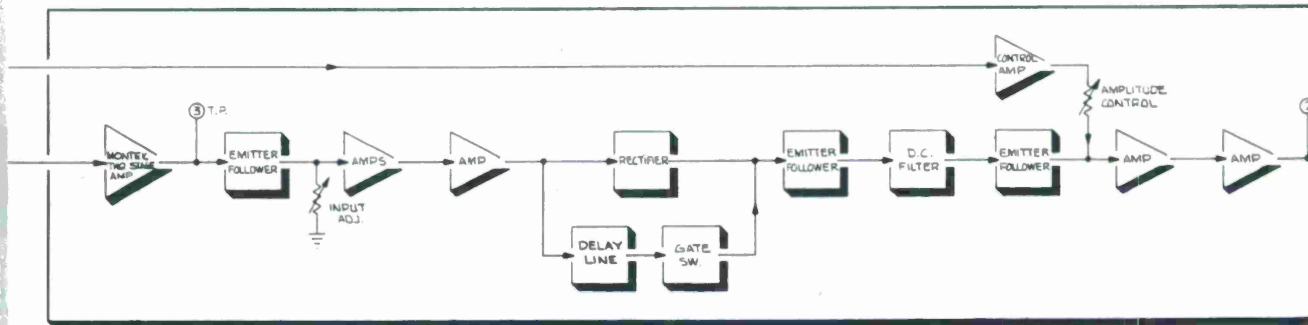

BIAS CONTROL

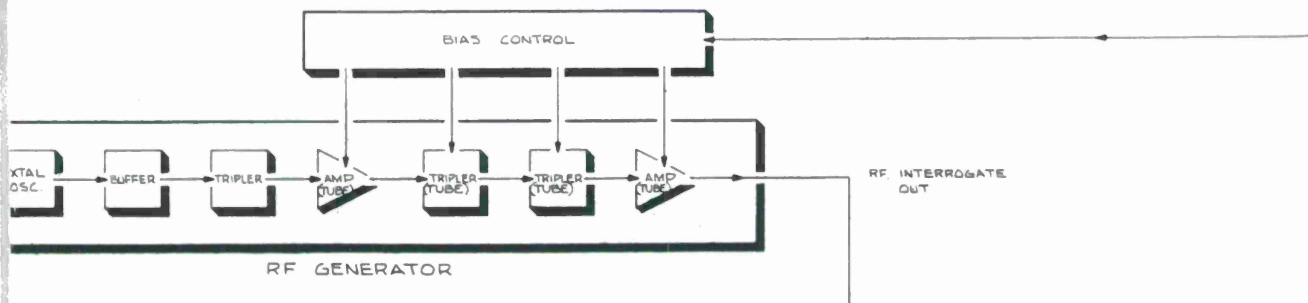



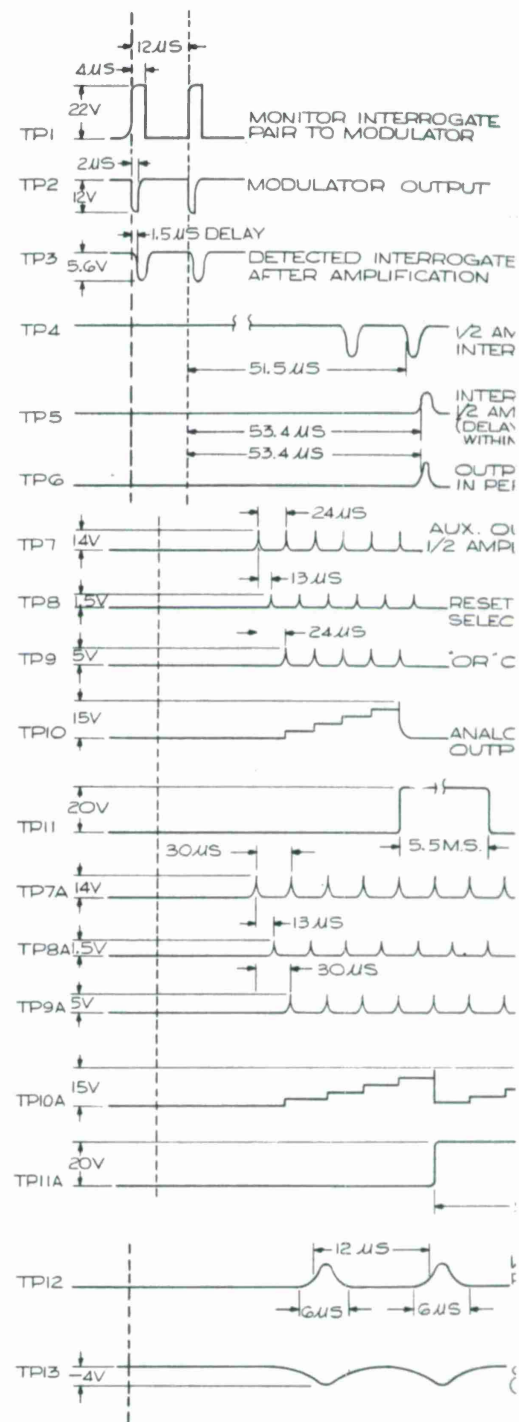
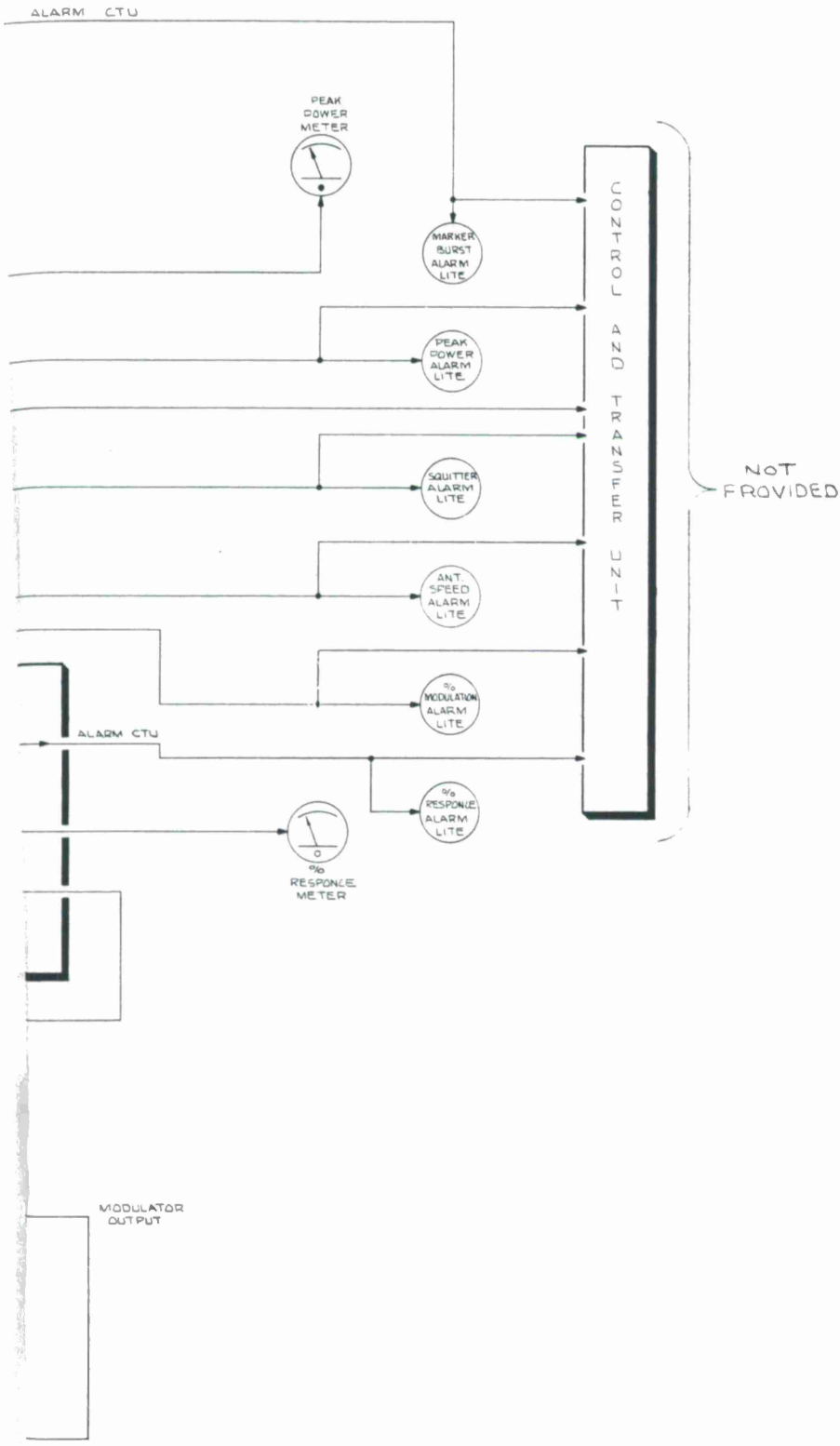

CT. INPUT PAIR  
 OUT OF STOR ESS OF 12 μS (SELECTOR)  
 DELAY M.V. USE MODULE

1 TOR  
 AMPLITUDE

IT  
 COUNTER

OUTPUT  
 NORTH OUTPUT FROM 1/2 AMPLITUDE SELECT.

RESET PULSE TO HALF AMPLITUDE SELECTOR  
 'OR' CIRCUIT OUTPUT

ANALOG STORAGE COUNTER OUTPUT  
 5.5 M.S. M.V. OUTPUT

OUTPUT TO CIRCUIT

POWER METER

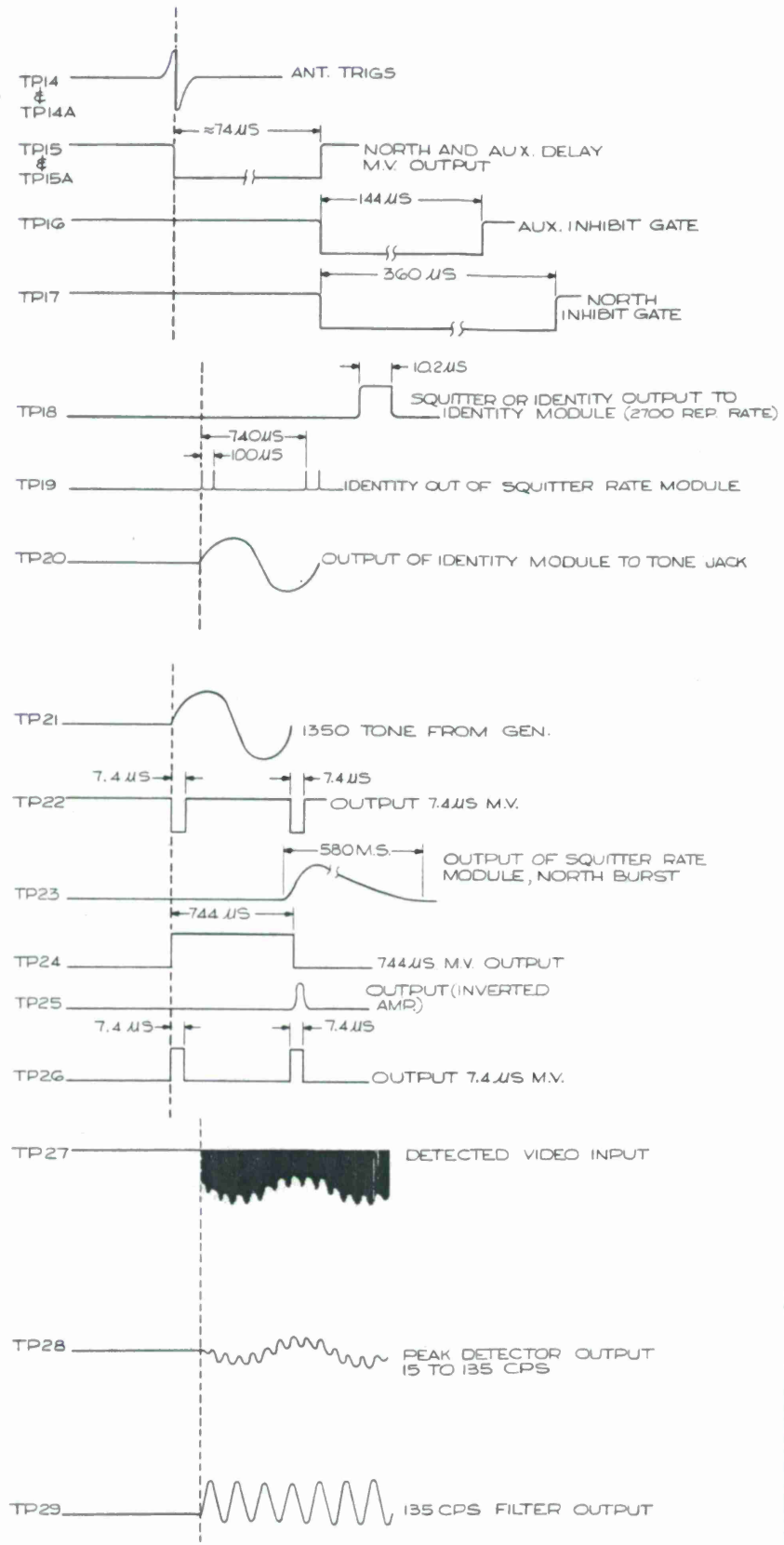

<b>MONTEK INC.</b> SALT LAKE CITY, UTAH	
A DIVISION OF MODEL ENGINEERING & MANUFACTURING CORP. HUNTINGTON, INDIANA	
SEMI-SOLID STATE TACAN MONITOR	
MGR. NAV-AIDS DEPT.	DEAN S. THORNBERG
TACAN TEAM CHIEF	THIEL J. GOMM
TACAN SYS. TECH.	K. CHAS. EDER
DESIGNED BY J. DEITZ	NAV-AIDS DEPT.
DATE 24 AUG 1964	REVISED BY 24 AUG 1964

FIGURE 2.4

## SECTION 3

### MODIFICATIONS AND INTERFACE PROBLEMS

#### 3.1 General

3.1.1 Modification and interface problems, which were encountered in the solid-state TACAN test bed, are discussed in this section of the report. The problems herein discussed are a result of the status of the major components upon receipt at Fort Dawes.

3.1.2 The problems encountered were chiefly accountable to the following:

- (a) Poor workmanship;
- (b) Poor design; and
- (c) Lack of coordination in the development of the components.

3.1.3 Individual circuit schematics, pertaining to modification and interface problems, and a composite system block diagram (reference Figure 3.10) are provided to aid in the discussion of the various problem areas.

#### 3.2 Problems Involving the Receiver-Coder Component

##### 3.2.1 Mixer To IF Strip Interface (Reference Figure 3.1)

3.2.1.1 Since no mixer was supplied with the solid-state receiver-coder, the AN/URN-3 mixer preamplifier assembly was modified to work in conjunction with the receiver. The use of the AN/URN-3 mixer preamplifier assembly enabled interrogation of the solid-state beacon system with the ARN-21 ( ) to be performed, as well as permitted system comparison testing.

3.2.1.2 The AN/URN-3 mixer transformer (T201) secondary was isolated (to eliminate any possibility of ground loops)

from the AN/URN-3 preamplifier by disconnecting pins 1 and 4 of the transformer secondary. Pin 1 of the secondary was attached to the solid-state receiver-coder strip via a 0.0047  $\mu$ farad capacitor. Pin 4 of the secondary was attached to the IF strip ground, thereby effectively floating the AN/URN-3 mixer transformer secondary from the AN/URN-3 preamplifier.

### 3.2.2 Decoder Input Circuitry Modification (Reference Figure 3.2)

3.2.2.1 The decoder would not pass interrogation pulses in the condition in which it was received. It can be seen by the "before modification" schematic that no capacitor bleed-off resistors were provided at either diode cathode; therefore, bleeder resistors were added to the circuit. After these two resistors were added, it was further necessary to increase the value of the input capacitor to improve the input signal response of the stage.

### 3.2.3 AGC Circuit Modification (Reference Figure 3.3A and 3.3B)

3.2.3.1 It was noted that after the receiver-coder had been turned on for a short period of time, the squitter output signal would start fluctuating and then break into oscillation.

3.2.3.2 It was found that transistor Q6 of the driver circuit in the AGC module was over-heating. As the transistor heated up, the AGC voltage would shift and, after a time, control would be lost completely.

3.2.3.3 The driver circuit was modified (reference Figure 3.3A), which solved the heating at transistor Q6; however, the modification shifted the AGC output voltage negative and, therefore, AGC was altered. The biasing problem was corrected by paralleling a base resistor of transistor Q5, thereby shifting the base voltage of transistor Q5 more negative (reference Figure 3.3B). The bias voltage shift, in turn, shifted the base voltage of transistor Q7 more positive, permitting AGC to be effective again.

3.2.4 Keyer To Receiver-Coder Interface Problem (Reference Figures 3.4, 3.5A, and 3.5B)

3.2.4.1 Upon integration of the keyer and receiver-coder circuitry, it was noted that priority of identity over squitter and interrogations had not been established. The solid-state switch of the keyer, the precedence circuit of the identity module, and the output circuitry of the decoder had to be altered to establish precedence.

3.2.4.2 The first step in solving the above problem was modification of the keyer output. This modification involved the addition of a 10K ohm resistor (Rx) from the keyer solid-state switch collectors to B+ (reference Figure 3.4), thereby applying B+ to the precedence circuit and to the decoder output circuit when no identity is to be transmitted. In order for identity to be transmitted, grounding of the precedence circuit and the decoder output circuit must occur.

3.2.4.3 The next step in solving the above problem was modification of the precedence circuit itself. This involved altering the diode blocking circuitry (see Figure 3.5A). The diode blocking circuitry was altered in such a manner that when B+ was applied to the precedence circuit from the keyer solid-state switch, the precedence diodes were reversed biased, thereby holding the identity signal in the off state. When B+ is applied to the precedence circuit, it is also applied to the decoder output circuit. The decoder output diode is forward biased and allows squitter to pass. When the keyer solid-state switch changes its state and applies ground instead of B+ to the precedence diodes, they would be forward biased and permit identity information to pass to the 14  $\mu$ sec output multivibrator of the identity module. At the same instant, ground was being applied to the decoder output, reverse biasing its diode and holding squitter off.

3.2.4.4 It was found after completion of the above two modifications that switching action from identity to squitter was slow. Further, squitter was feeding back, through the solid-state keyer switch, and randomly mixing with the identity signal while it was being transmitted.

3.2.4.5 To overcome the above two problems, the following two modifications were employed (see Figure 3.5B). First,

the solid-state keyer switch was modified by breaking the collector circuit between the second and third transistors, and changing the 10K ohm resistive load to two 2.2K ohm resistors. This permitted two separate outputs. One output was connected to the precedence circuit and the other output was connected to the decoder output circuit, thereby effectively isolating the two circuits. The second modification, needed to speed up the switching action when switching from the identity mode to the squitter mode, was accomplished by changing  $R_y$  from a 22K ohm to an 11K ohm resistor, and adding a 1000 pf speed-up capacitor across the 11K ohm resistor. This changed the rise and fall time of the switching action of the keyer from 80 to 5  $\mu$ secs. No further problems were encountered by the interface of the keyer, identity module, and decoder module.

3.2.5 Receiver-Coder Output - Transmitter Input Interface (Reference Figure 3.6)

3.2.5.1 Pulse shaping circuitry (part of the receiver-coder unit) was provided to change the timing module output signal, of the receiver-coder into a Gaussian shaped pulse. This shaped pulse was to be used to shape the final output RF signal of the transmitter; however, the transmitter circuitry was also designed to provide a Gaussian shaped (modulated) final output RF signal. Since the transmitter circuitry provided for the necessary timing



of the Gaussian pulse generated in the transmitter, the receiver-coder pulse shaper module was not used.

3.2.5.2 The output trigger pulse of the receiver-coder was taken from the timing module output emitter-follower (see Figure 3.6). This output was approximately 22 V peak in amplitude, and four  $\mu$ secs wide at the half-amplitude voltage points. When the output was connected to the solid-state transmitter, the reference circuits (Pseudo-Gaussian pulse shaping circuits) of the transmitter were overdriven and distorted severely. Inserting a 200 ohm resistor in series with the output of the timing module output emitter-follower attenuated the output trigger amplitude to 10 V. This modification solved the interface problem between the receiver-coder and transmitter.

### 3.3 Transponder Interface (General) (Reference Figure 3.10)

3.3.1 The various solid-state and AN/URN-3 components were interconnected in the following manner:

- (a) The AN/URN-3 mixer was integrated with the receiver-coder as per paragraph 3.2.1.
- (b) The receiver-coder was integrated with the solid-state transmitter as per paragraph 3.2.5
- (c) The local oscillator output of the solid-state transmitter was attenuated by a 10 db pad and connected to J201, local oscillator input of the AN/URN-3 mixer. The attenuator was used to prevent the mixer diodes from operating in their non-linear regions.

- (d) The north trigger cable was connected to TB #43 of the solid-state receiver-coder.
- (e) The auxiliary trigger cable was connected to TB #42 of the solid-state receiver-coder.
- (f) Antenna tone was simulated with a TS382 B/U audio oscillator. The audio oscillator output was connected to TB #19 of the receiver-coder.

3.3.2 The Control Duplexer of the AN/URN-3 was utilized as an integral part of the SSTGS in the following manner:

- (a) The output of the AN/URN-3 klystron to the control duplexer was disconnected at E1162. The solid-state transmitter RF output was then connected to a 10-foot length of RG-213 cable, which was connected to E1162 in place of the klystron input.
- (b) The output of the AN/URN-3 preselector to the AN/URN-3 receiver was disconnected. The preselector output was then connected to the AN/URN-3 mixer input, J202.
- (c) The RF output of the control duplexer was then connected to the SA-420 Switch Test Adapter RF input jack.
- (d) One output of the SA-420 Switch Test Adapter was connected to a TS-118 dummy load; the other output was connected to the RF output line to the antenna, via a 20 db directional coupler.

#### 3.4 Interface and Internal Circuits Involving the Solid-State Monitor

- 3.4.1 Percent Response - Pulse Space - Reply Delay Module Alarm and Meter Readout Problems - The Percent Response - Pulse Space - Reply Delay alarm light and meter would not respond properly to the input signals

which triggered the circuitry involving the meter and alarm light.

3.4.1.1 Improper Delay Timing

The first problem involving this module was that the 50  $\mu$ sec delay multivibrator in the Percent Response module took into account the delay that occurred in the transponder; however, the 3.4  $\mu$ sec delay that occurred to the monitor interrogate pulse in the monitor circuitry was not taken into account. This error prevented coincidence from occurring between the monitor interrogate pulse and the transponder response pulse. This problem was eliminated by increasing the 50  $\mu$ sec delay multivibrator delay time to 53.4  $\mu$ secs.

3.4.1.2 Meter Pegged Down Scale

The Percent Response meter pegged down scale when the transponder was responding to the monitor interrogation pulses. The meter leads were reversed to eliminate this problem.

3.4.1.3 Meter Pegged At Full Scale

The meter pegged at full scale deflection when the transponder was responding to 100% of the monitor interrogations. The meter adjustment was unable to eliminate this pegged condition. Since too much current was forced through the meter under 100% response conditions, the current limiting resistance was increased to eliminate this problem.

3.4.1.4 Insufficient Percent Response Alarm Light Adjustment and Light Alarm During Identity (Reference Figure 3.7)

Sufficient alarm light drive voltage was unattainable at the base of Q312 (reference Figure 3.7) with the percent response adjustment. The voltage at the base of Q312 would drop too low during the occurrence of identity. The circuitry was altered (reference Figure 3.7) to eliminate these problems.

3.4.2 ALC and Modulator Module (Reference Figure 3.8)

Insufficient gain was developed in the ALC loop involving the ALC and modulator module and the RF generator. The ALC loop would not control the amplitude of the RF generator output signal due to insufficient gain provided in the ALC loop. This problem was eliminated by providing an amplifier to increase the gain of the loop.

3.4.3 Improper Reference Burst Timing in the Squitter Rate Module (Reference Figure 3.9)

The reference bursts in the decoded composite line from the one-half amplitude module were out of synchronization with respect to the reference trigger pulse inputs in the squitter rate module by 74  $\mu$ secs. The timing error prevented complete removal of the reference burst pulses from the decoded composite signal. This problem was eliminated by alteration of the trigger input circuitry to provide proper timing.

3.4.4 Video Input Attenuator in the One-Half Amplitude Select Module

The video input attenuator could not be switched in or out of the input circuitry. When the peak power calibration switch was set

in the calibrate mode, no signal was applied to the one-half amplitude input circuitry. When the switch was set in the direct mode, the signal was properly coupled into the one-half amplitude select module input circuitry. This problem was eliminated by correctly wiring the switch into its associated circuitry.

#### 3.4.5 General Problems

Many circuitry errors existed in the various monitor schematics supplied by the vendor and many components were not soldered into their respective circuitry; however, additional information involving these problems may be noted in Appendixes II and III of this report.

### 3.5 Monitor Interface (Reference Figure 3.10)

The solid-state monitor was integrated with the solid-state transponder in the following manner.

- 3.5.1 A monitor antenna was fabricated and installed near the AN/URN-3 antenna. The monitor antenna cable was then connected to the MON ANT jack (located on the patch panel of the solid-state monitor component).
- 3.5.2 The north and auxiliary antenna triggers were tapped from TB42 and TB43 of the solid-state receiver-coder terminal board, and were connected to the AUX TRIG and NORTH TRIG jacks (located on the patch panel of the solid-state monitor).
- 3.5.3 The output of the audio oscillator (TS-382B/U), which was used for simulating the antenna tone signal for the identity circuits of the receiver-coder, was connected to the receiver-coder terminal board at TB19 and to the ANT TONE input jack (located on the patch panel of the monitor).
- 3.5.4 The MONITOR INTERR output jack (located on the patch panel of the monitor) was connected to a 20 db directional coupler at the antenna side of the SA-420 Switch Test Adapter.
- 3.5.5 The CONTROL DUPLEXER UNIT input jack (located on the patch panel of the monitor) was connected to the SA-420 Switch Test Adapter voltage probe, which was modified to function as an RF probe.

MIXER TO IF INTERFACE

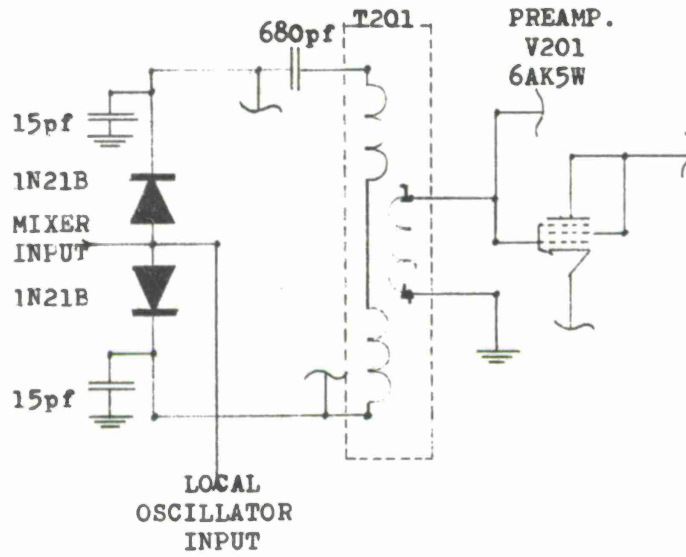

BEFORE MODIFICATION

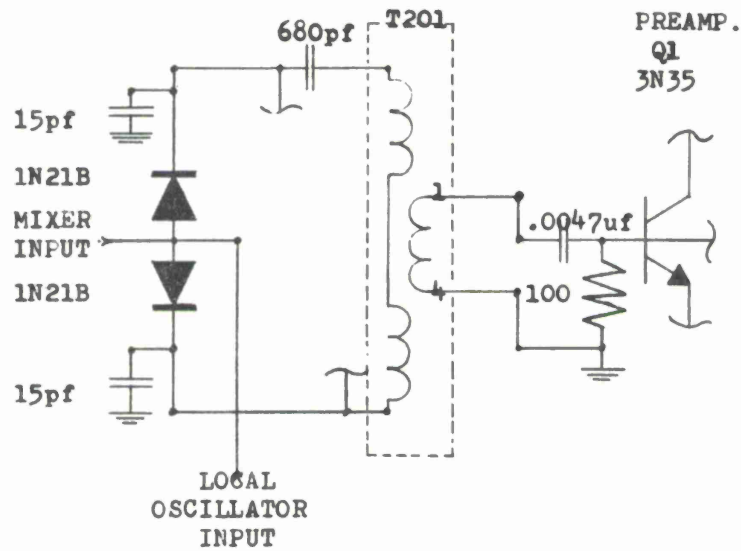

AFTER MODIFICATION

FIGURE 3.1

### DECODER INPUT CIRCUITRY MODIFICATION

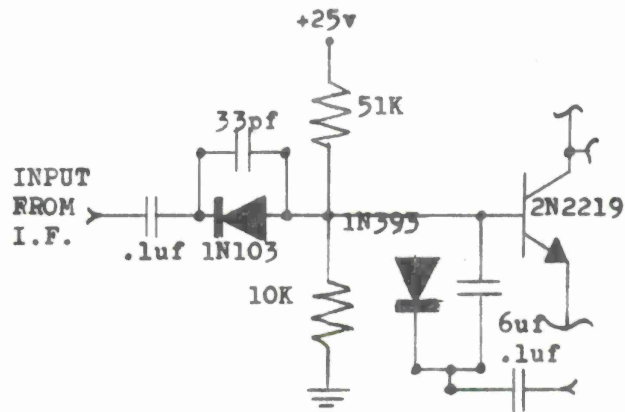

BEFORE MODIFICATION

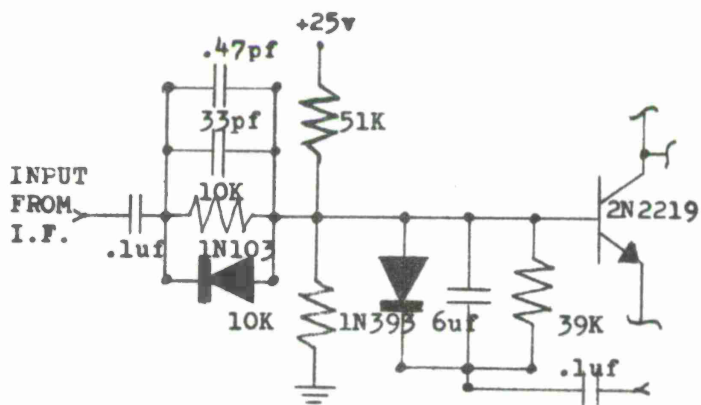

AFTER MODIFICATION

FIGURE 3.2



AGC CIRCUIT MODIFICATION

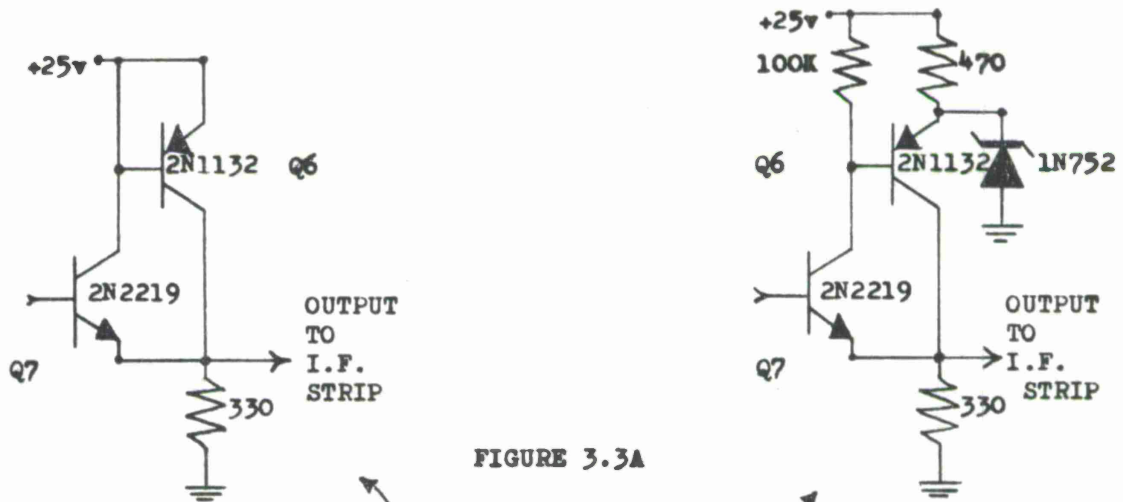

FIGURE 3.3A

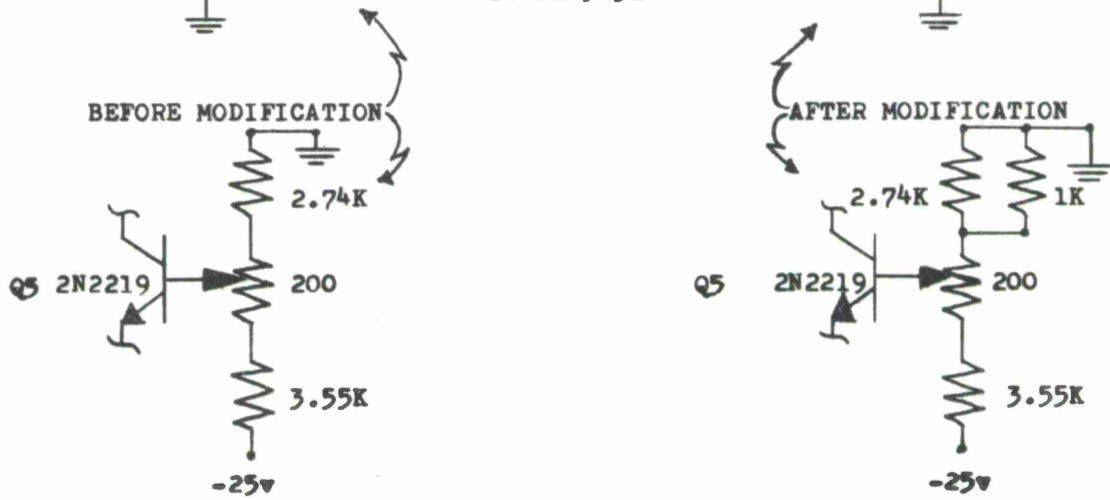
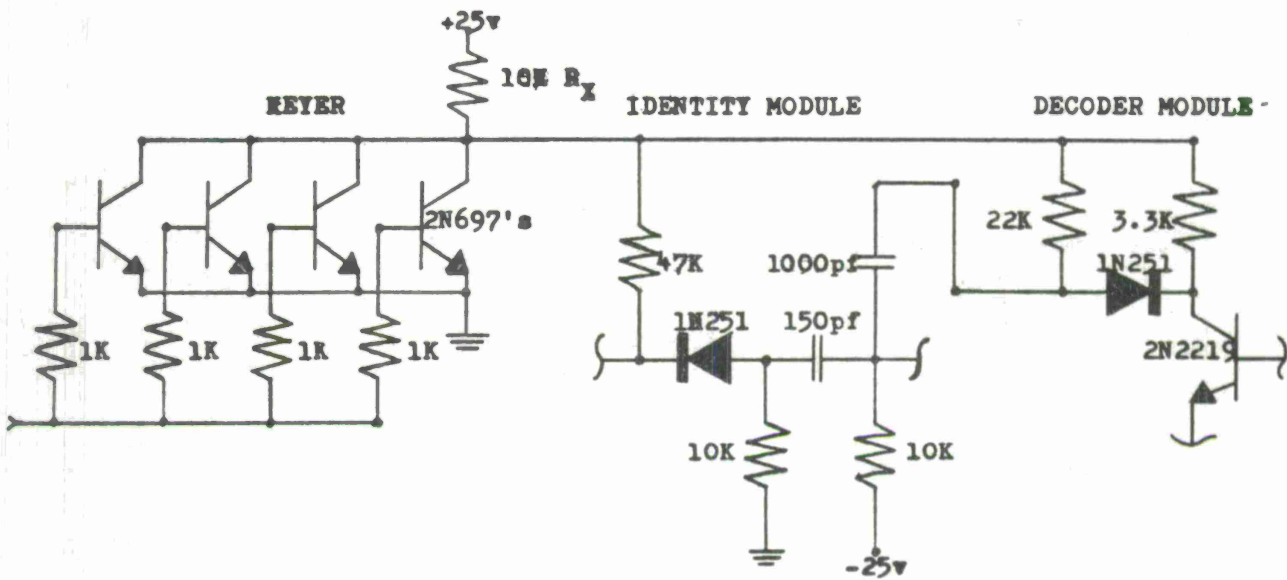

FIGURE 3.3B

KEYER TO RECEIVER-CODER INTERFACE PROBLEM



ORIGINAL CIRCUIT AFTER INSTALLING 10K RESISTOR  $R_X$

FIGURE 3.4

KEYER TO RECEIVER-CODER INTERFACE PROBLEM

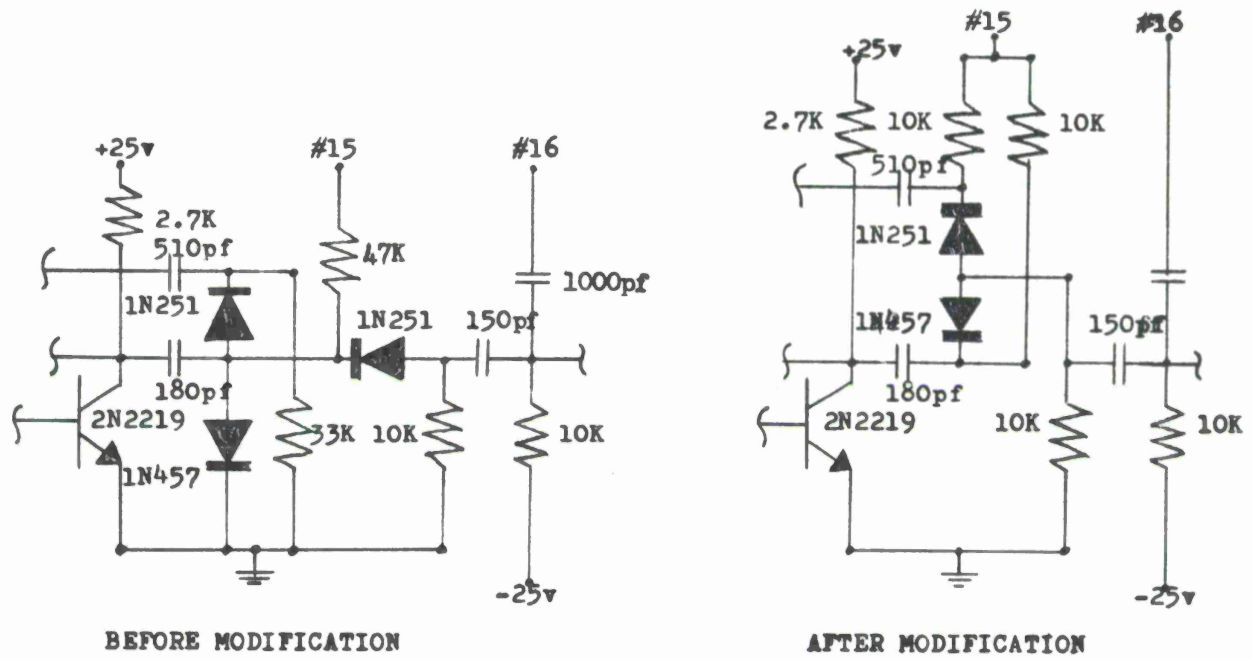

PRECEDENCE CIRCUIT MODIFICATION  
FIGURE 3.5A

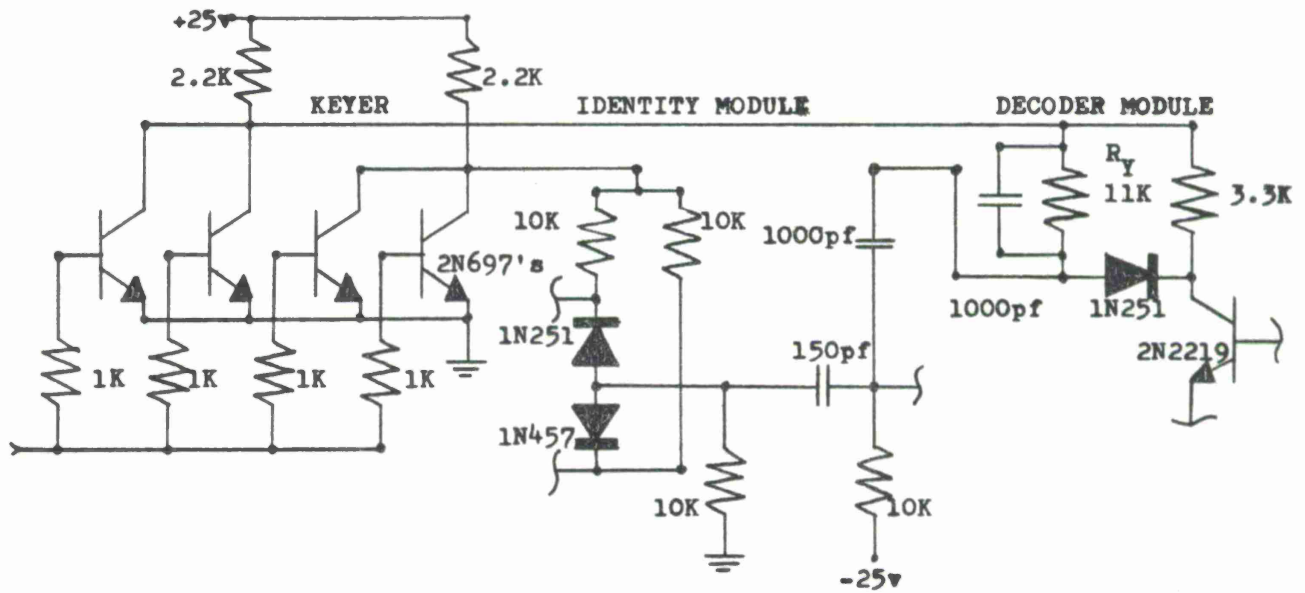
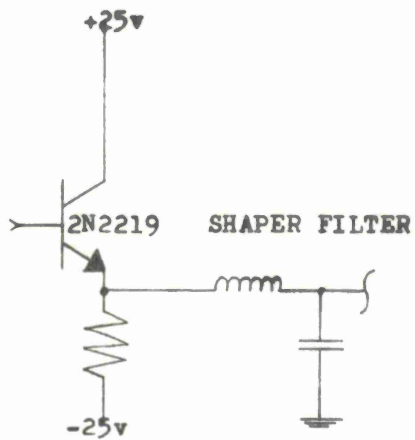
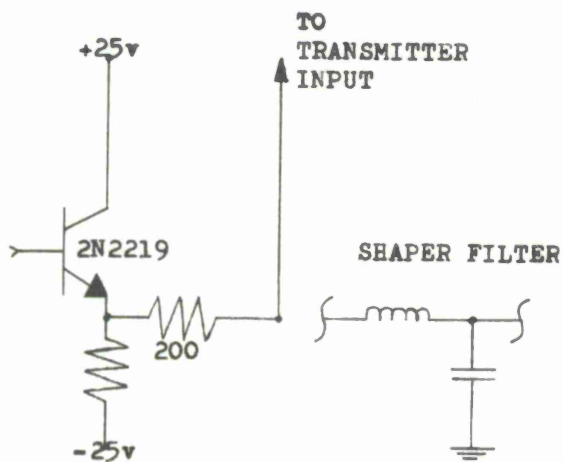

FIGURE 3.5B

RECEIVER-CODER OUTPUT - TRANSMITTER INPUT INTERFACE



BEFORE MODIFICATION



AFTER MODIFICATION

FIGURE 3.6

PERCENT RESPONSE MODIFICATION

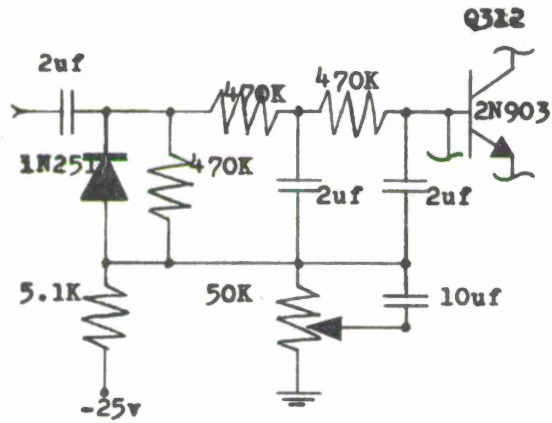

BEFORE MODIFICATION

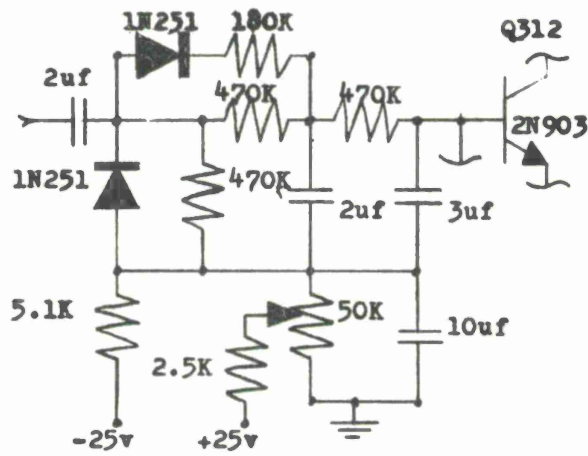

AFTER MODIFICATION

FIGURE 3.7

ALC AND MODULATOR MODULE AMPLIFIER

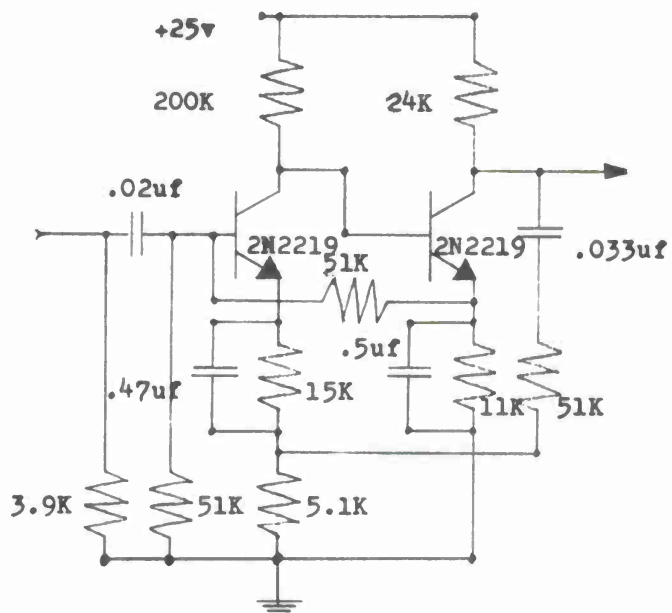
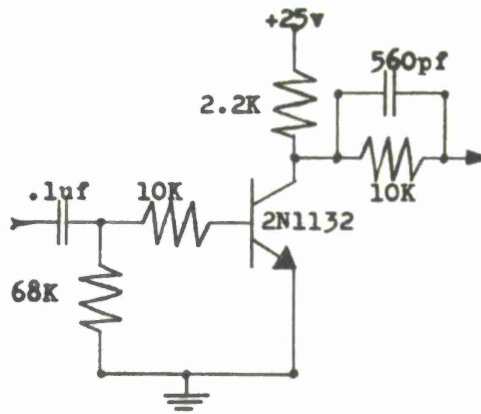
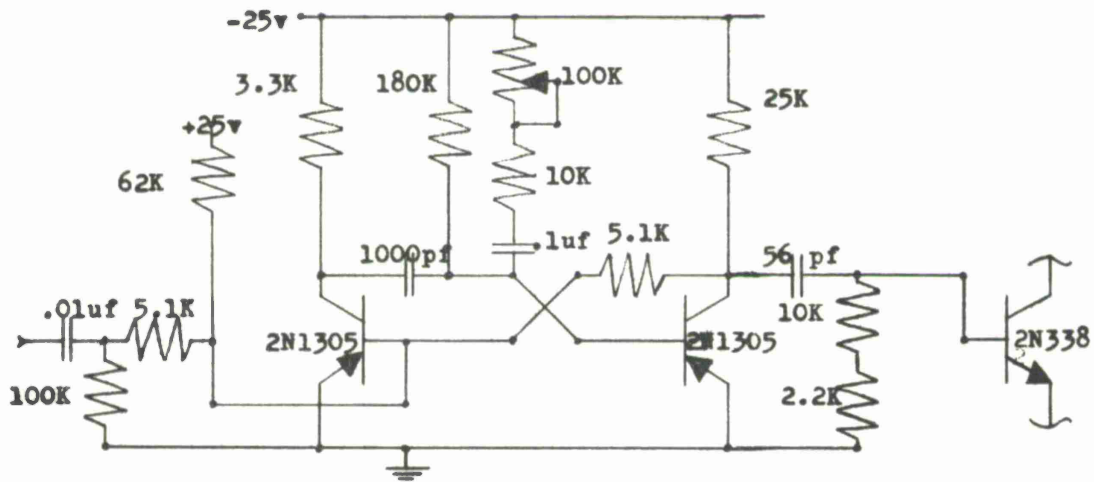

FIGURE 3.8

SQUITTER RATE MODULE MODIFICATION



BEFORE MODIFICATION



MONTEK AUXILIARY DELAY M.V.

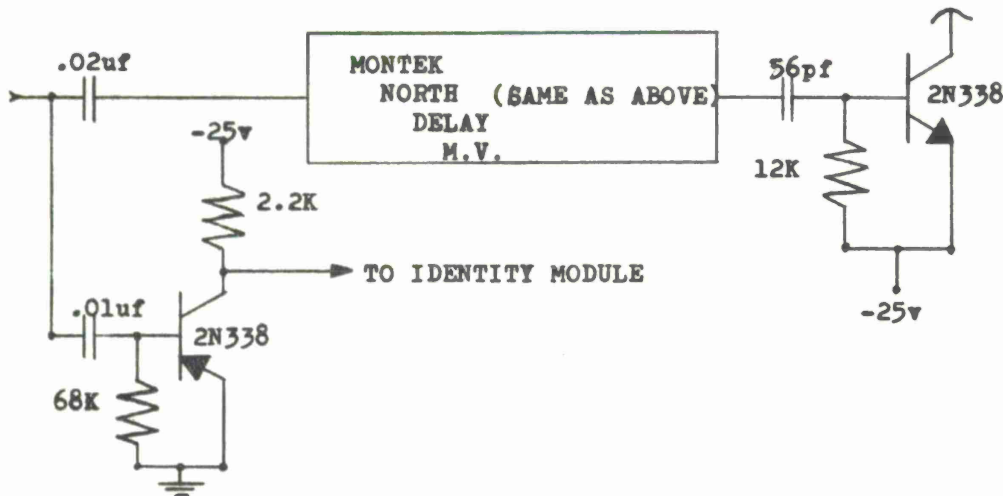
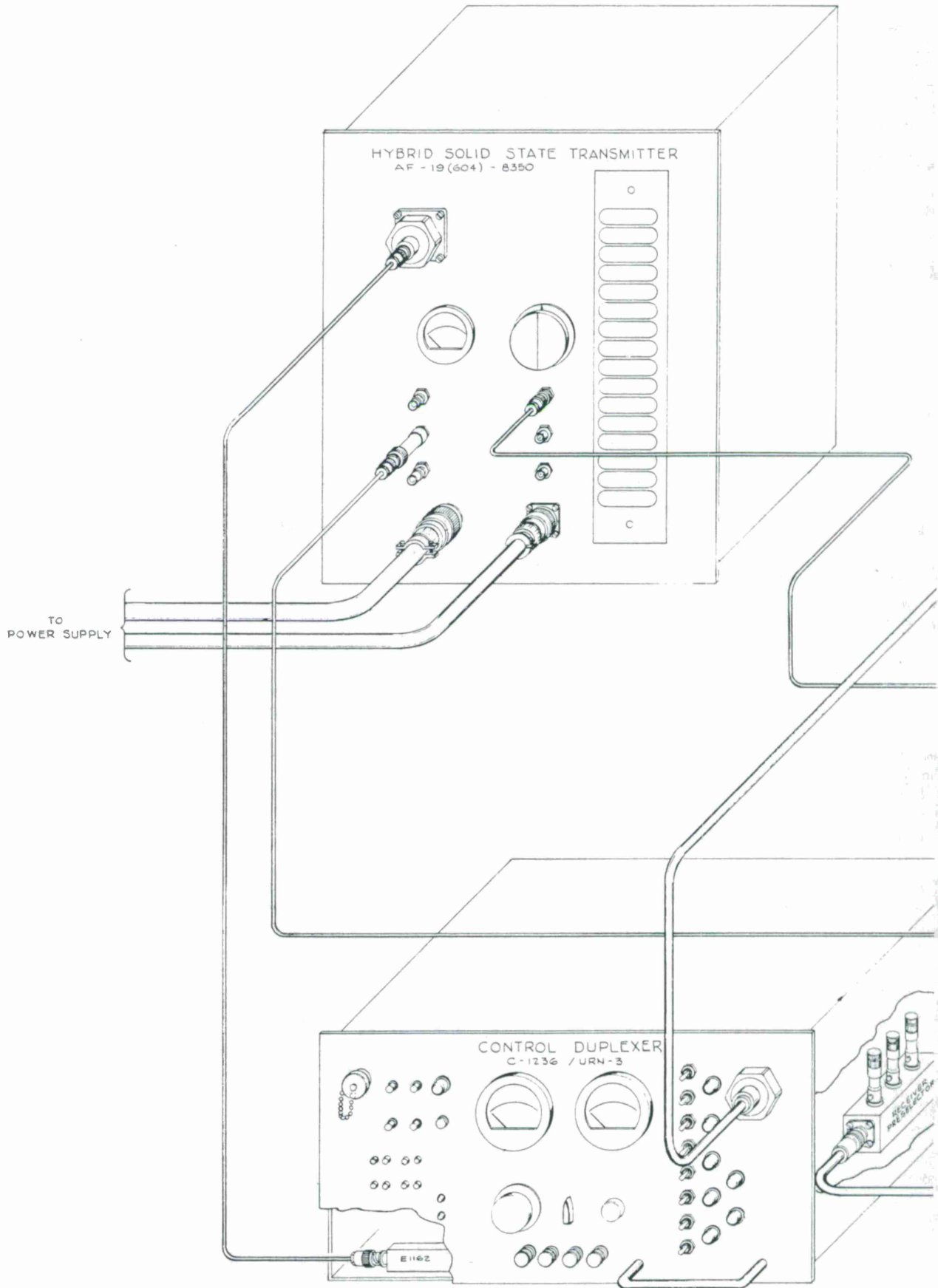
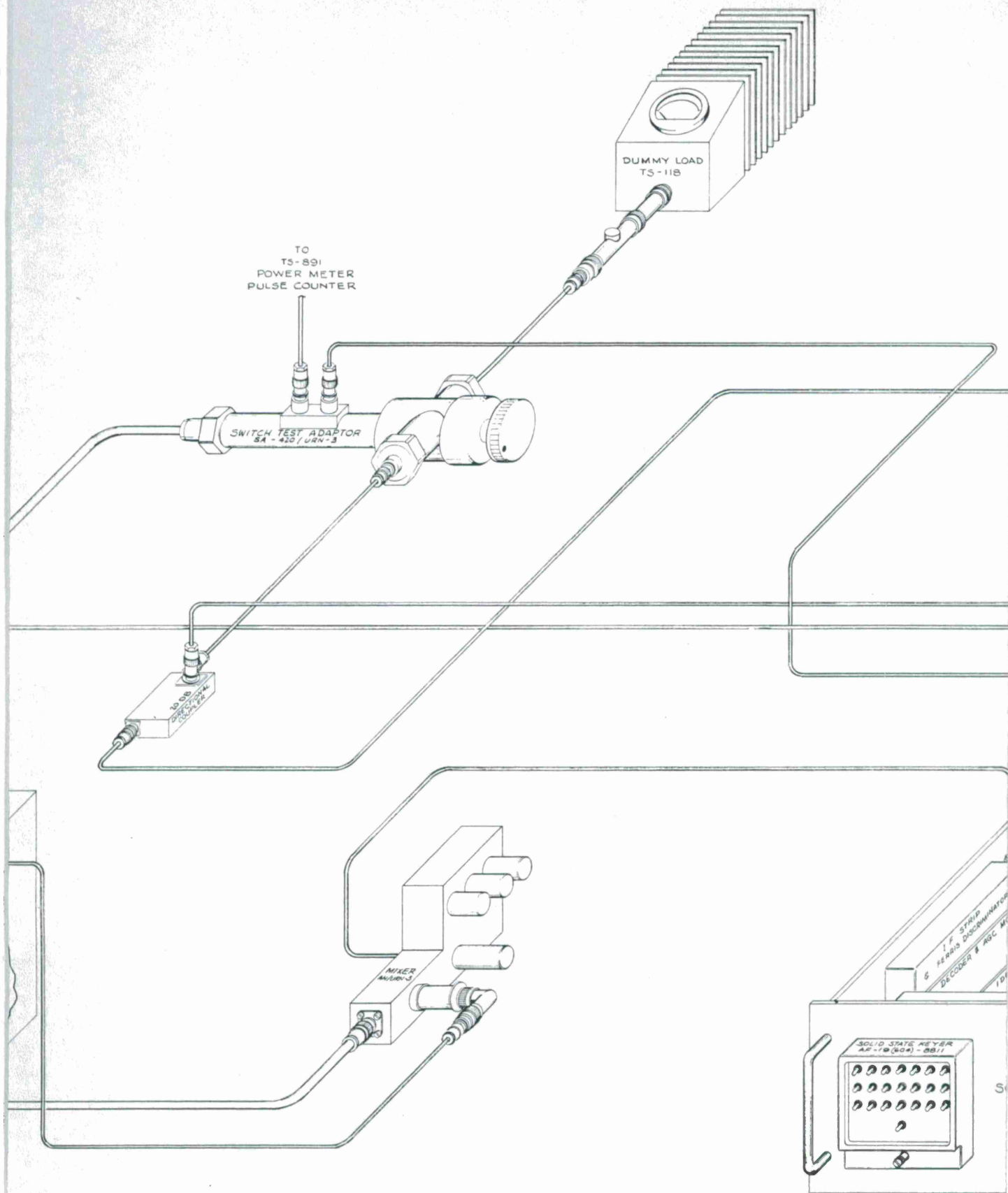
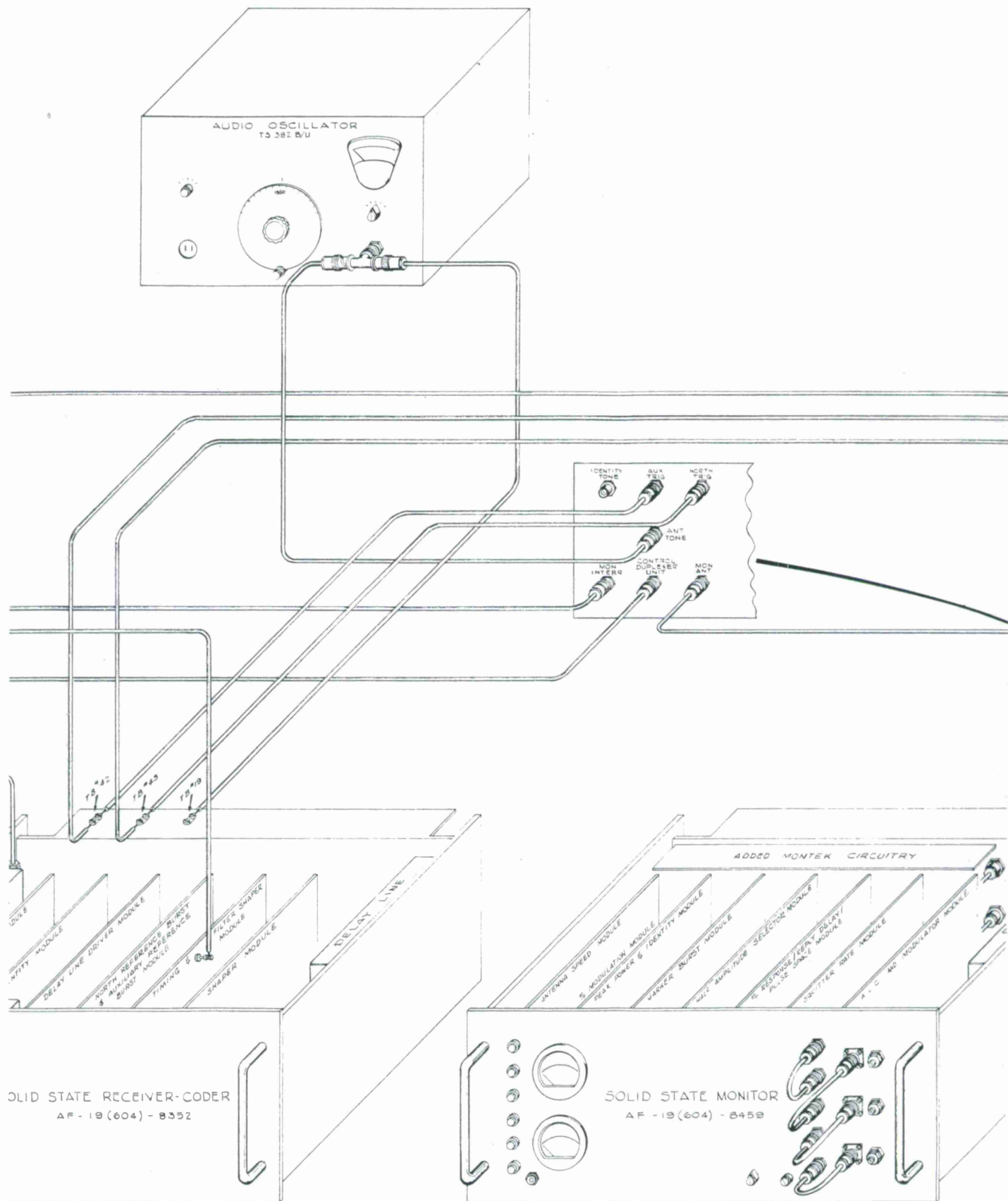

FIGURE 3.9









62c

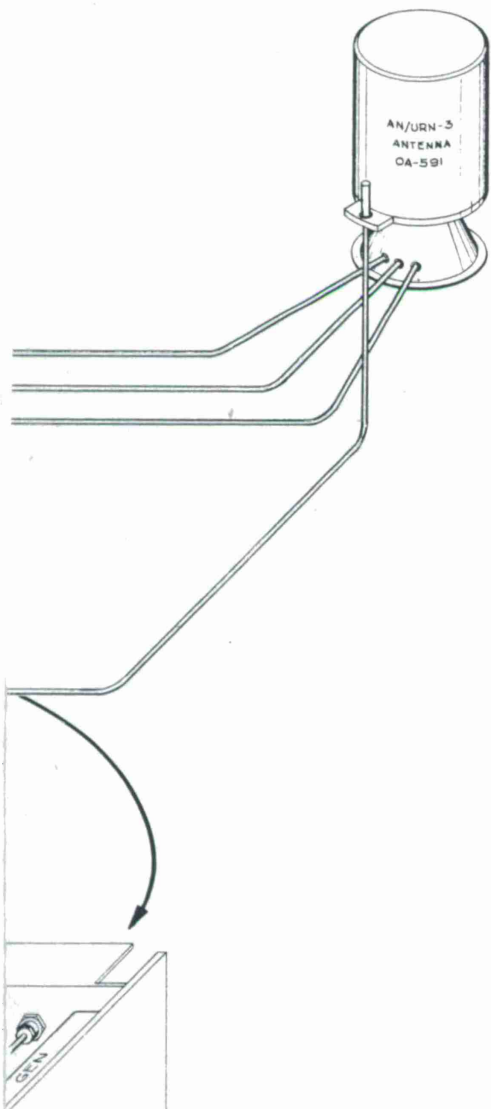

<b>MONTEK INC.</b> SALT LAKE CITY UTAH A DIVISION OF MODEL ENGINEERING & MANUFACTURING CORP. HUNTINGTON, INDIANA	
SOLID STATE TRANSDONDER AND MONITOR TEST BED INTER-CABLING	
MGR. NAV-AIDS DEPT.	DEAN S. THORNBURG
TACAN TEAM CHIEF	THIEL J. GOMM
TACAN SYS. TECH.	HAROLD C. RENNER
DRAWN BY TOM MIYA	NAV-AIDS DEPT
DATE ISSUED 28 AUG. 1964	DRAWING NO. 64-234-5

**FIGURE 3.10**

## SECTION 4

### TACAN TEST RESULTS

#### 4.1 General

This portion of the report provides the results of the tests that were performed to compare the operation of the AN/URN-3 test bed with the solid-state TACAN test bed (SSTB).

#### 4.2 Transponder Test Results

All tests were performed at ambient temperature conditions. The results of each TACAN system check which was taken is recorded as per the following outline:

##### Type TACAN Test Performed

- (a) Test Tolerance: (As per MIL-STD-291 and T.O. 31R4-1-129, "Alignment and Checkout for TACAN Facilities", dated 8 February 1960, USAF distribution 30 June 1961.)
- (b) AN/URN-3 Results:
- (c) Test Equipment: (Used in the above test, and test procedure where needed)
- (d) SSTB Results:
- (e) Test Equipment: (Used in the above test, and test procedures where needed)

##### 4.2.1 Receiver IF Bandpass

- (a) Test Tolerance: No tolerance.
- (b) AN/URN-3 Results: Total bandpass measured 3.75 Mc.
- (c) SSTB Results: Total bandpass measured 2.0 Mc.
- (d) Equipment: 545A Tektronix Oscilloscope, TS-419/U Signal Generator, HP-431B Power Meter, and SG-121A/URN-3. (Also, see NOTE under Paragraph 4.2.2.)

4.2.2 Ferris Discriminator Bandpass

- (a) Test Tolerance: No tolerance.
- (b) AN/URN-3 Results: Low Q tank had a bandpass from 61.56 Mc to 64.44 Mc, a total of 2.88 Mc. High Q tank had a bandpass from 62.50 Mc to 63.50 Mc, a total of 1.0 Mc. The output of the ferris discriminator was  $63 + .38$  Mc and  $63 - .37$  Mc, or a 0.75 Mc bandpass.
- (c) SSTB Results: Low Q tank had a bandpass from 62.12 to 63.87 Mc, a total of 1.75 Mc. High Q tank had a bandpass from 62.50 Mc to 63.50 Mc, a total of 1.0 Mc. The output of the ferris discriminator was  $63 + .38$  Mc and  $63 - .37$  Mc, or a .75 Mc bandpass.
- (d) Equipment: 545A Tektronix Oscilloscope, TS-419/U Signal Generator, HP-431B Power Meter, and SG-121A/URN-3.

NOTE

The following test set-up was used in taking the above checks. The TS-419/U was modulated with the output pulse of the SG-121A/URN-3. The output power of the TS-419 was monitored by the HP-431B power meter. The output of the TS-419 was connected to the low pass filter input connector. The oscilloscope was synchronized from the mod. synch jack of the SG-121/URN-3.

In the case of the AN/URN-3, the oscilloscope was connected to the high Q tank output (TP303 of the AN/URN-3 receiver), and the TS-419 was adjusted for a peak of the inserted pulse pair. This peak was assumed



to be 63 Mc on the dial of the TS-419. All other readings were taken using this as a reference point. The output of the TS-419 was monitored at all times and kept at a constant level while the bandpass checks were made. The frequency of the TS-419 was varied until the 0.707 point of the pulse was reached. The frequency of the TS-419 was then noted and recorded.

In the case of the SSTTB, the oscilloscope was connected to the high Q tank output (narrow band test point), and the TS-419 was adjusted for a peak of the inserted pulse pair. This peak occurred at the same point on the TS-419 dial as on the AN/URN-3. The rest of the test was completed as per the above paragraph.

#### 4.2.3 Receiver Blanking Time

- (a) Test Tolerance: Minimum of 40  $\mu$ secs; maximum of 60  $\mu$ secs.
- (b) AN/URN-3 Results: Set at 40  $\mu$ secs.
- (c) SSTTB Results: Must be adjusted to a minimum of 47  $\mu$ secs to blank the receiver during transmission of the output pulse pair.
- (d) Equipment: 545A Tektronix Oscilloscope.

#### 4.2.4 Receiver Decoder

- (a) Test Tolerance: No tolerance.
- (b) AN/URN-3 Results: The receiver decoder will decode those pulse pairs which have between pulse spacings of 10.8  $\mu$ secs to 13.2  $\mu$ secs. This equals a tolerance of  $12 \pm 1.2$   $\mu$ secs.



- (c) SSTTB Results: The receiver decoder will decode those pulse pairs which have between pulse spacings of 9.9  $\mu$ secs to 15  $\mu$ secs. This equals a tolerance of  $12 + 3 \mu$ secs and  $12 - 2.1 \mu$ secs.
- (d) Equipment: 545A Tektronix Oscilloscope, TS-419/U Signal Generator, and Model 4904 Berkley Double Pulse Generator used for both the AN/URN-3 and the SSTTB.

#### 4.2.5 Receiver Output Count

- (a) Test Tolerance:  $2700 \pm 90$  pulses per second.
- (b) AN/URN-3 Results: Squitter count ranged from 2696 to 2714, a range from +14 to -4, which equals a total of 18 pulses per second.
- (c) SSTTB Results: Squitter count ranged from 2686 to 2755, a range from +55 to -14, which equals a total of 69 pulses per second.
- (d) Equipment: Beckman Counter, Model 7360, used for both the AN/URN-3 and the SSTTB.

#### 4.2.6 Receiver Sensitivity

- (a) Test Tolerance: At 60% reply to interrogations, sensitivity should equal -93 dbm.
- (b) AN/URN-3 Results: Receiver sensitivity found to be -90.0 dbm at 60% replies.
- (c) SSTTB Results: Receiver sensitivity found to be -75.75 dbm at 60% replies.
- (d) TS-890 and TS-891, both modified, used for both the AN/URN-3 and the SSTTB.

NOTE

The TS-890 modification will be explained in the RF spectrum test portion, since it does not involve the receiver circuitry of the TS-890.

The TS-891 was modified due to the different receiver delays of the two systems. The delay line and gate generator portions of the pulse counter circuits were removed and replaced by a variable delay multivibrator and a gate generator multivibrator.

4.2.7 North Burst Check

- (a) Test Tolerance: 12 pulse pairs per second;  $30 \pm 0.3$   $\mu$ sec pulse pair spacing.
- (b) AN/URN-3 Results: 12 pulse pairs spaced 30.3  $\mu$ secs apart; quite noisy along the base line.
- (c) SSTTB Results: 12 pulse pairs spaced 30  $\mu$ secs apart; clean base line.
- (d) Equipment: 545A Tektronix Oscilloscope used for both the AN/URN-3 and the SSTTB.

4.2.8 Auxiliary Burst Check

- (a) Test Tolerance: Six pulse pairs per second;  $24 \pm 0.25$   $\mu$ sec pulse pair spacing.
- (b) AN/URN-3 Results: Six pulse pairs spaced 25.2  $\mu$ secs; quite noisy along the base line.
- (c) SSTTB Results: Six pulse pairs spaced 24  $\mu$ secs; clean base line.
- (d) Equipment: 545A Tektronix Oscilloscope used for both the AN/URN-3 and the SSTTB.

#### 4.2.9 Identity Signal

- (a) Test Tolerance: A series of pulses, transmitted at a 1350 cps rate, having  $740 \pm 50$   $\mu$ sec between pulse pairs. An equalizing pulse pair shall be transmitted  $100 \pm 10$   $\mu$ secs after each identification pulse pair.
- (b) AN/URN-3 Results: 735  $\mu$ sec for identity pulse pair; equalizer pulse pair occurred 100  $\mu$ secs after identity pulse pair.
- (c) SSTTB Results: 745  $\mu$ secs for identity pulse pair; equalizer pulse pair occurred 100  $\mu$ secs after identity pulse pair.
- (d) Equipment: 545A Tektronix Oscilloscope used for both the AN/URN-3 and the SSTTB.

#### NOTE

The RT-220/ARN-21 interrogated and locked-on the solid-state system. Since the identity specifications call for a pulse spacing of  $740 \pm 50$   $\mu$ secs, the 1350 antenna tone frequency was varied (TS-382B/U Audio Oscillator) to the extremes, namely  $1350 \pm 90$  cps while monitoring the identity tone on the ARN-21 headsets. The results of the test follow:

At 1350 cps, 740  $\mu$ secs -- Identity Clear

At 1440 cps, 690  $\mu$ secs -- No Identity

At 1266 cps, 790  $\mu$ secs -- No Identity

The identity was then varied until the identity code was distinguishable at the ARN-21 headsets. The results follow:

1382 cps, 724  $\mu$ secs -- Identity Clear --  
Tolerance -16  $\mu$ secs

1333 cps, 752  $\mu$ secs -- Identity Clear --  
Tolerance +12  $\mu$ secs

From the results of this test, it would seem that the tolerance of the  $740 \pm 50$   $\mu$ secs is much too loose and should be tightened up.

4.2.10 Precedence Establishment

- (a) Test Tolerance: Azimuth, identity, interrogations, and squitter (in that order of priority.)
- (b) AN/URN-3 Results: Priority was checked by synchronizing the test equipment with the various pulses; i.e., the test equipment was synchronized with azimuth pulses and verification was made by visual check that azimuth bursts were present at all times; the test equipment was synchronized on identity pulses and the transmission of identity was verified; interrogations and squitter are blanked out; the test equipment was synchronized on squitter; and interrogation pulses and blanking of interrogations and squitter was observed when identity and azimuth were being transmitted. Results of the above tests indicated that priority was established.
- (c) SSTTB Results: Test procedure was the same as on the AN/URN-3 above. Results indicated that priority is established.
- (d) Equipment: 545A Tektronix Oscilloscope used on both the AN/URN-3 and the SSTTB.

4.2.11 Output Pulse Count

- (a) Test Tolerance:  $7200 \pm 180$  pulses per second.
- (b) AN/URN-3 Results: Output count ranged from 6640 to 7090; deviation = 450 pulses.
- (c) SSTTB Results: Output count ranged from 7196 to 7291; deviation = 95 pulses.

(d) Equipment: Beckman Counter, Model 7360, used on both the AN/URN-3 and the SSTTB.

4.2.12 Pulse Droop

(a) Test Tolerance: Prior to antenna modulation, no pulse in the north reference burst may deviate from the average peak amplitude by more than  $\pm 2\%$ ; no pulse in the auxiliary reference burst may deviate from the average peak amplitude by more than  $\pm 1\%$ .

(b) AN/URN-3 Results:

Auxiliary: Minimum pulse = 0.68 vpk  
Maximum pulse = 0.68 vpk  
Average pulse = 0.68 vpk  
Droop = 0.00% No droop present

North: Minimum pulse = 0.70 vpk  
Maximum pulse = 0.75 vpk  
Average pulse = 0.74 vpk  
Droop = +1.69% (maximum pulse)  
Droop = -5.08% (minimum pulse)

(c) SSTTB Results:

Auxiliary: Minimum pulse = 1.4 vpk  
Maximum pulse = 1.5 vpk  
Average pulse = 1.45 vpk  
Droop = +3.45% (maximum pulse)  
Droop = -3.45% (minimum pulse)

North: Minimum pulse = 1.43 vpk  
Maximum pulse = 1.65 vpk

Average pulse = 1.58 vpk

Droop = +4.43% (maximum pulse)

Droop = -9.49% (minimum pulse)

(d) Equipment: 545A Tektronix Oscilloscope used on both the AN/URN-3 and the SSTTB.

4.2.13 Pulse Shape

(a) Test Tolerance: The detected pulse envelope must conform to the following dimensions:

Rise time, 10 to 90% =  $2.5 \pm .5$   $\mu$ secs; Pulse top, at no time can the amplitude drop below the level of the 95% amplitude points; Pulse duration, at the half amplitude points,  $3.5 \pm .5$   $\mu$ secs; Fall time, 10 to 90% =  $2.5 \pm .5$   $\mu$ secs.

(b) AN/URN-3 Results:

Output Pulse:	1st Pulse	2nd Pulse
Rise time =	1.5 $\mu$ secs	1.5 $\mu$ secs
Duration =	3.0 $\mu$ secs	3.1 $\mu$ secs
Fall time =	1.5 $\mu$ secs	1.5 $\mu$ secs
Pulse top =	OK	OK

(c) SSTTB Results:

Output Pulse:	1st Pulse	2nd Pulse
Rise time =	2.8 $\mu$ secs	3.0 $\mu$ secs
Duration =	3.75 $\mu$ secs	3.85 $\mu$ secs
Fall time =	3.2 $\mu$ secs	3.2 $\mu$ secs
Pulse top =	OK	OK

(d) Equipment: 545A Tektronix Oscilloscope used on both the AN/URN-3 and the SSTTB.

4.2.14 Spectrum

- (a) Test Tolerance: The energy level contained in a 0.5 Mc band centered on a frequency  $\pm 0.8$  Mc from the channel frequency is at least 60 db below the energy level contained in a 0.5 Mc band centered on the channel frequency. The energy level contained in a 0.5 Mc band, centered on a frequency  $\pm 2$  Mc from the channel frequency, is at least 65 db below the energy level contained in a 0.5 Mc band centered on the channel frequency.
- (b) AN/URN-3 Results:
- At  $+0.8$  Mc = down 15.366 db
  - At  $-0.8$  Mc = down 18.066 db
  - At  $+2$  Mc = down 31.733 db
  - At  $-2$  Mc = down 31.733 db
- (c) SSTTB Results:
- At  $+0.8$  Mc = down 21.44 db
  - At  $-0.8$  Mc = down 29.67 db
  - At  $+2$  Mc = down 28.41 db
  - At  $-2$  Mc = down 41.74 db
- (d) Equipment: Modified TS-890 used on both the AN/URN-3 and the SSTTB.

NOTE

Due to the inaccuracy of the input attenuator, AT6944, in the TS-890 that was made available to the four-man team, the following modification was incorporated on the TS-890 to enable the team to perform (as accurately as possible) spectrum comparison checks on the SSTTB versus the AN/URN-3 system.



The input attenuator, AT6944, was replaced by a variable Arra attenuator (0 to 60 db, insertion loss 1 db). The step attenuator was bypassed by disconnecting P6953 and P6954, and inserting a jumper coaxial cable from J6751 to J6947; therefore, the only attenuation applied to the incoming TACAN RF pulses was that of the Arra attenuator.

The TS-890 was then set up in the same manner when conducting a normal spectrum check. The bandshift knob was placed in its "0" position and the Arra attenuator adjusted for midscale (100) on the power comparison indicator. The Arra attenuator's db level was then read. The bandshift knob was then rotated through its remaining four positions. In each position, the Arra attenuator was read. The reading was then subtracted from the '0' position Arra reading, the difference being the number of db down from the transmitter channel (center) frequency.

Example: 0 position = 40 db      attenuation inserted  
for a midscale reading  
of the power comparison  
indicator.

+8 position = 25 db      attenuation inserted for  
a midscale reading of the  
power comparison indicator.

Difference = 15 db      down from the channel  
(center) frequency.

#### 4.2.15 Power Output

- (a) Test Tolerance: AN/URN-3 peak power out with a SAL-39A klystron should be a minimum of 5 KW. The SSTTB transmitter peak power out should be 1 KW. The above indicated power output values were computed by using the standard USAF Equivalent Duty Cycle (EDC) formula and Peak Power formula (PK. P.) as follows:

$$\text{EDC} = K \times \text{P.W.} \times \text{PRF} \text{ and } \text{PK. P.} = \text{Avg. P.} / \text{EDC}$$

Where K = (constant) 0.752      Where Avg. P. = average power

P.W. = pulse width

EDC = Equivalent duty cycle

PRF = pulse recurrence frequency

- (b) AN/URN-3 Results:

Average power = 109.6 watts

Peak power = 6.85 KW

- (c) SSTTB Results:

Average power = 23.85 watts

Peak power = 1,041 watts

- (d) Equipment: 545A Tektronix Oscilloscope and TS118 Wattmeter used on both the AN/URN-3 and the SSTTB.

#### NOTE

Average power was computed using the TS-118 wattmeters prescribed formula:

$$\text{Watts} = K \text{ factor} \times \text{Meter Reading} \times C \text{ Factor}$$

#### 4.2.16 Overall Delay

- (a) Test Tolerance: Delay measured from the leading edge of the second interrogate pulse to the leading edge of the second reply pulse shall be  $50 \pm .25$   $\mu$ secs.
- (b) AN/URN-3 Results: Total delay = 49.85  $\mu$ secs.

(c) SSTTB Results: Total delay = 50.75  $\mu$ secs.

(d) Equipment: 545A Tektronix Oscilloscope and TS-890 used on both the AN/URN-3 and the SSTTB.

#### 4.2.17 Antenna Rotation

(a) Test Tolerance: 810  $\pm$  4 cycles per second.

(b) AN/URN-3 Results: Varied between 813 and 814 cycles per second.

(c) SSTTB Results: Since the same antenna was used, the results are as noted above.

(d) Equipment: Beckman Counter, Model 7360.

#### 4.3 Monitor Test Results

##### 4.3.1 Marker Burst Module

One complete reference group per revolution must be lost before an alarm is triggered.

##### 4.3.2 Squitter Rate Module

Squitter output was not monitored; only the squitter rate alarm indicator (no squitter circuitry) was provided. Specifications state that squitter rate must not deviate more than 2700  $\pm$  90 pps. The squitter rate module effectively blanks out the north and auxiliary bursts from the decoded composite line leaving only identity and squitter pulses.

##### 4.3.3 Peak Power and Identity Module

The peak power alarm point can be adjusted. The alarm point was set for -6 db, and when beacon power was decreased by that amount, an alarm was noted. Identity must be monitored with a headset; some background noise was noted between identity transmissions. The monitor does not have a visual identity monitoring facility.

#### 4.3.4 Percent Response - Reply Delay - Pulse Space Module

Percent response portion of this module can be set to alarm at any given percent reply level above 50%. The module was adjusted for an alarm condition at the 60% reply point as indicated on the percent response meter. Transmitter overall delay was varied. TACAN specifications state that the tolerance of the transmitter overall delay shall be  $50 \pm .25$   $\mu$ secs; however, the alarm points of the monitor were noted to be .75  $\mu$ secs from the original setting. The transmitter pulse encoding tolerance was varied. TACAN specifications require a between pulse tolerance of  $12 \pm .25$   $\mu$ secs; however, the monitor alarmed at  $12 + 1$   $\mu$ secs (13  $\mu$ secs) and  $12 - 2$   $\mu$ secs (10  $\mu$ secs).

#### 4.3.5 Antenna Speed Module

The antenna tone signal was simulated by a TS-382B/U audio oscillator. The antenna tachometer speed, according to AN/URN-3 specifications, shall not deviate more than  $\pm 0.5\%$  before an alarm is indicated. Antenna speed was varied and the alarm conditions are as follows:

- (a) 1350 cps --- normal, no alarm
- (b) 1357 cps --- alarm, (+7 cps = 0.518%)
- (c) 1342 cps --- alarm, (-8 cps = 0.592%)

#### 4.3.6 Percent Modulation Module

The monitor must alarm when the modulated antenna radiation pattern drops below 10% of the 15 or 135 cycle component. The percent modulation module was adjusted so that the percent modulation alarm indicator lamp was alarming at 10% modulation and not alarming at 20% modulation. It should be noted that only the 135 cycle modulation has any effect on the percent modulation alarm indicator lamp. The 15 cycle modulation can be lost completely and no alarm is

indicated. This function alarms only when the detected 135 cycle component of the radiated pattern drops below a preset level. The percent modulation can be varied over any range with no alarm indicated, as long as the 135 cycle component is above the alarm threshold level previously set up.

#### 4.4 Shaper Module

4.4.1 The shaper module described herein was furnished as part of the receiver-coder. It was not integrated into the SSTTB for the following reasons:

- (a)  $\cos^4 \theta$  and  $\cos^2 \theta$  pulses (shaped pulses) are generated in the hybrid solid-state transmitter; therefore, a shaped pulse from the receiver-coder is not required.
- (b) The transmitter requires a faster rise and fall time trigger than the shaper module provides.
- (c) Modifying the receiver-coder was much easier and more practical than changing an excessive number of components in the transmitter.
- (d) The occurrence of the shaped pulse had to follow the occurrence of the pedestal pulse, which was generated in the transmitter.

4.4.2 The shaper module, however, was individually checked by inserting the output pulse of the timing module to the input of the shaper module (reference Figure 2.1).

4.4.3 The shaper module is composed of a shaper filter circuit and a shaper circuit. The pulse pair output of the timing module (22 V positive-going, four  $\mu$ secs at the half amplitude point, pulse spaced 12  $\mu$ secs from the leading edge of the first pulse of a pair to the leading edge of the second pulse of a pair) arrives at the shaper filter and

is filtered to a near Gaussian output pulse pair. The shaper filter is composed of six coils, seven capacitors, and two resistors in an 11-pole, maximally flat, low pass filter arrangement.

4.4.4 The output of the shaper filter, which is a near Gaussian pulse pair, is applied to the shaper portion of the shaper module. The shaper portion of the shaper module consists of an emitter follower input amplifier, followed by an amplitude selector (shaping circuit), an operational amplifier, and an emitter follower output amplifier.

4.4.5 The amplitude selector portion of the shaper provides controls for base (skirts) and peak shaping of the pulse pair. The output of the amplitude selector is applied to the operational amplifier. The operational amplifier consists of a two-stage amplifier employing negative feedback. The operational amplifier has two controls, a gain control (pulse amplitude) and a high frequency control. The effect of the high frequency control was not fully tested, since this shaped pulse was not used. A spectrum test was not performed on the pulse. The output of the operational amplifier is applied to the emitter follower output stage.

#### 4.5 Solid-State Gate Modulator

4.5.1 The gate modulator described herein was furnished to the Montek team from the vendor on 13 April 1964. The gate modulator was provided under Contract AF 19(604)-8352. For a detailed discussion of the modulator, refer to Gate Modulator - Preliminary Report, April 1964.

4.5.2 Although the gate modulator was not utilized in the solid-state transponder, it was individually checked with satisfactory results. A positive gate pulse, 18 volts in amplitude and 24  $\mu$ secs wide (measured at the one-half amplitude points), was applied to the input of the gate modulator. The output signal from the modulator was then checked and found to be a negative pulse 24  $\mu$ secs in width (measured at the one-half amplitude points) and 44 volts in amplitude. A schematic of the gate modulator is shown in Figure 4.1.

GATE MODULATOR SCHEMATIC

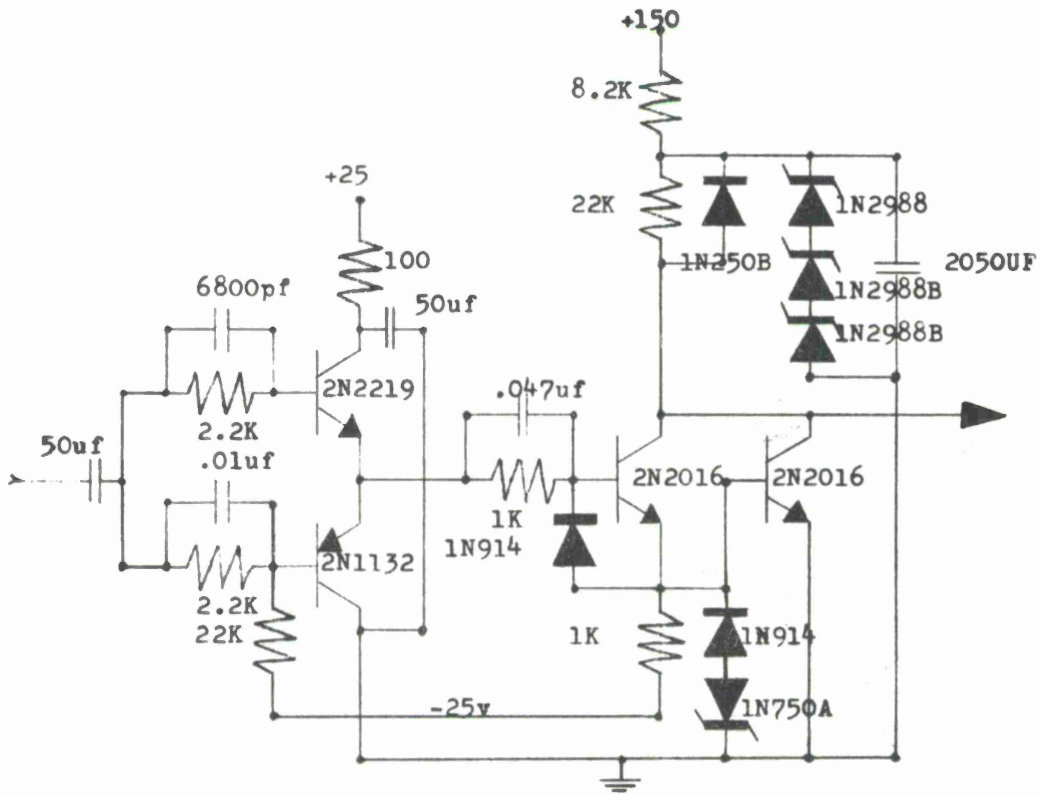

FIGURE 4.1



## SECTION 5

### CONCLUSIONS AND RECOMMENDATIONS

#### 5.1 Solid-State Components

##### 5.1.1 Receiver-Coder

5.1.1.1 A number of receiver-coder improvements was performed by the team, as indicated in Section 3 of this report; however, other circuitry which was not materially improved, such as the Ferris discriminator and the AGC circuitry, still displays marginal operation. The solid-state keyer performed satisfactorily and featured good logic philosophy and packaging. The receiver shaper circuitry, which was provided as part of the receiver-coder, was not required in the accomplishment of transponder test bed integration.

5.1.1.2 The overall receiver-coder circuitry, which displayed operative shortcomings, should be improved upon and should be altered to provide for the following:

- (a) Assurance against possible false DME lock-on;
- (b) Assurance of sufficient echo suppression;
- (c) Use of state-of-the-art circuitry; and
- (d) Use of state-of-the-art anti-jam techniques.

##### 5.1.2 Transmitter (Semi Solid-State)

5.1.2.1 The wave shaping control loop contained insufficient frequency response and dynamic range. Spurious RF radiation in the transmitter was so severe that the controlled output waveform was seriously distorted when the side panels were put on the transmitter. Positioning of components and wires within the transmitter was very critical.

5.1.2.2 It is recommended that additional analysis and improvement of the output waveform controlling feedback loop be performed and the circuit status be upgraded such that the conditions where merits of this control technique are not hampered by circuitry

design, which limits the frequency response and dynamic range of the control loop. Also, the radiation pickup problems must be reduced to the extent that neither the reference generator nor any part of the loop are affected by the spurious radiation. Grounding techniques used also plagued the solid-state transmitter breadboard, and careful consideration should be given to this problem. A complete design review should be accomplished prior to any possible "next generation" effort.

5.1.2.3 The side-band power requirements should be considered from the viewpoint described in Section 2 of the technical documentary report entitled "A Study of Exhibit AFCRC 59-17 and AN/TRN-17 Beacon Transponder Set TACAN."

5.1.2.4 Various new types of devices, which have been developed and tested for shaped pulse (TACAN) final RF amplifier purposes, should be thoroughly investigated in the design of future TACAN transmitters, with the objective of eliminating the requirement for spectrum filters and the spectrum control feedback loop.

### 5.1.3 Monitor (Semi Solid-State)

5.1.3.1 The condition of the solid-state monitor, when delivered to ESD, was unacceptable due to the following:

- (a) Workmanship;
- (b) Monitored parameter tolerances and alarm threshold resolutions;
- (c) Incomplete circuitry; and
- (d) Errors and incompatibility between the schematics and the hardware.

5.1.3.2 It is the team's opinion that monitor philosophy and circuitry in this (limited parameter) monitor has been made obsolete by recent advancements in transponder monitor technology; however,

a number of techniques incorporated in this monitor could be incorporated in future transponder monitors. The degree of development of solid-state TACAN monitors has greatly increased MTBF, even though more parameters are being monitored. Current state-of-the-art of existing solid-state monitors is such that significant enhancement of flying safety may be assured through proper monitoring of more of the critical transponder parameters.

#### 5.1.4 Experimental Solid-State Transponder/Monitor System

5.1.4.1 A considerable amount of testing has been performed on the test bed equipment. Some test results of the solid-state equipment were better than those of the AN/URN-3 test bed; however, in some cases, the converse results were obtained. In some instances, the test results of the experimental transponder/monitor breadboards were inferior to those of the AN/URN-3 due to the use of less than ideal parts borrowed from the AN/URN-3, which was required in order to provide a workable solid-state transponder system.

5.1.4.2 With the exception of the transmitter final amplifier, the experimental transponder/monitor system demonstrated that solid-stating TACAN ground systems is practical.

5.1.4.3 It is recommended that the experimental solid-state test bed be maintained as part of the TACAN test bed for future experimental purposes. The experimental test bed incorporates a variety of concepts and techniques which should be considered when future solid-state TACAN ground systems are designed and/or fabricated.

#### 5.2 Test Bed Facility

5.2.1 The TACAN test bed located at Fort Dawes must be relocated due to the closing of the Fort Dawes facility. The test bed can prove to be extremely

valuable to future USAF TACAN efforts; i.e., while the TACAN test bed was being maintained by the team, it was used by other contractors for testing of TACAN jamming and anti-jamming equipment.

5.2.2 It is recommended that the TACAN test bed be relocated at a site that will provide good environmental conditions, such that the following tests may be performed:

- (a) Testing of all antennas (including the experimental static antennas) to measure operational parameters, such as antenna radiation pattern;
- (b) Anti-jamming;
- (c) Voice TACAN;
- (d) Investigation of false lock-on problems and azimuth error problems; and
- (e) Flight checks.

### 5.3 Advanced Solid-State TACAN System

5.3.1 At present, the USAF does not possess a TACAN ground station which can satisfy all the needs of the EMS program and the requirements of USAF. Although the AN/TRN-17 TACAN ground system was intended to satisfy the existing EMS TACAN needs, many deficiencies (indicated in TDR Report, "A Study of Exhibit AFCRC 59-17 and AN/TRN-17 Beacon Transponder Set TACAN") exist, such as:

- (a) Excessive deployment time;
- (b) Heating problems in the shelter;
- (c) Excessive antenna negative angle energy;
- (d) Monitor deficiencies, such as inability to sense out-of-tolerance conditions in the north and auxiliary bursts, no monitor back-up facilities, and insufficient parameters monitored;
- (e) Inadequacies in the built-in test equipment, which is provided to maintain the station as required by Exhibit AFCRC 59-17;
- (f) Excessive amount of depot level maintenance;
- (g) Excessive weight for a transportable TACAN ground system;
- (h) Inadequate anchor plates;
- (i) Excessive MTTR and insufficient MTBF; and

(j) Remote and local control equipment too complex.

5.3.2 An advanced solid-state TACAN beacon system should be designed and developed, employing concepts and techniques used in the experimental test bed only where they are superior to existing techniques and hardware. It appears feasible to design and develop an advanced TACAN system in approximately one and one-half years that will fulfill the needs of the EMS and USAF requirements.

5.3.3 An advanced TACAN system should be designed and developed in such a manner as to eliminate the above mentioned TACAN shortcomings, and to provide the following:

- (a) Provide for testing purposes, the necessary electronic equipment (built-in transistor tester) which would display the curves and parameters of the various semiconductors used throughout the system.
- (b) Provide additional test equipment, such as: a digital counter, a frequency meter, a spectrum analyzer, an IF signal generator, an average power meter, and others. All routine testing should be performed without external patching.
- (c) Provide an antenna mast which will raise the TACAN antenna in a manner that will greatly reduce the present AN/TRN-17 erecting time and labor.
- (d) Provide a monitor that will adequately monitor all significant transponder parameters to assure safety of flight.

#### 5.4 Characteristic

5.4.1 The characteristic (see Appendix I) provides information concerning more advanced TACAN concepts, and includes current thinking, techniques, and desired results as seen by TACAN users, operators, and developers.

5.4.2 It is highly recommended that the characteristic be thoroughly analyzed as the USAF develops a specification for an advanced, highly mobile, TACAN system.

APPENDIX I

MILITARY CHARACTERISTIC  
BEACON-TRANSPONDER SET, TACAN, AN/TRN( )

T A B L E O F C O N T E N T S

<u>Section</u>	<u>Page</u>
I GENERAL .....	87
1.1 Scope .....	87
1.2 Description .....	87
II APPLICABLE DOCUMENTS .....	88
III REQUIREMENTS .....	91
3.1 Preproduction Testing .....	91
3.2 Items To Be Furnished By The Contractor .....	91
3.3 General Requirements .....	92
3.4 Aerospace Ground Equipment .....	107
3.5 Selection of Specifications and Standards .....	107
3.6 Design and Construction .....	107
3.7 Performance .....	111
3.8 Details of Components .....	116
3.9 Parts Numbering .....	181
3.10 Color .....	181
3.11 Finish .....	181
3.12 Weight .....	182
3.13 Operation Markings .....	182
3.14 Identification of Product .....	182
3.15 Workmanship .....	182
3.16 Design Approval .....	182
IV QUALITY ASSURANCE PROVISIONS .....	184
4.1 Responsibility for Inspection .....	184
4.2 Classification of Tests .....	184
4.3 Preproduction Tests .....	184
4.4 Acceptance Tests .....	190
4.5 Operational Data .....	195
4.6 Inspection and Preservation .....	196
4.7 Test Plan .....	196
4.8 Acceptance Test Report .....	196
4.9 Failure Data Reports .....	196
4.10 Refurbishing .....	196
V PREPARATION FOR DELIVERY .....	197
VI NOTES .....	198
6.1 Intended Use .....	198
6.2 Ordering Data .....	198
6.3 Complete Type Designation .....	199
6.4 First Article Approval .....	199



APPENDIX I

MILITARY CHARACTERISTIC  
BEACON-TRANSPONDER SET, TACAN, AN/TRN- ( )

SECTION I

GENERAL

1.1 Scope.- This characteristic, in its entirety, will describe a light-weight air and/or ground transportable, solid-state, dual TACAN ground station, complete with built-in test equipment, dual monitors, remote/local control facilities, and local shelter facilities. The AN/TRN-( ) is to be used in the USAF's "Emergency-Mission-Support (EMS)" program as a short range air navigational aid, and as indicated in Section VI of this characteristic.

1.2 Description.- The transponder and antenna equipment covered by this characteristic produces and radiates a signal capable of providing azimuth and station identification information to an unlimited number of (airborne type) TACAN receivers. The system simultaneously provides distance information (in response to interrogations) for at least 100 (airborne type) TACAN and/or DME interrogator equipments. The equipment is intended for installation in a small (walk-in) portable shelter. The facility transmits amplitude modulated and time coded pulses on any one of 126 one-megacycle (Mc) TACAN channels, between 962 to 1024 Mc (low band) and 1151 to 1213 Mc (high band), which provide visual azimuth bearing information in the aircraft, as well as station identification. The transponder receiver receives interrogation pulse pairs transmitted from aircraft on one of 126 one-Mc channels between 1025 and 1150 Mc (receiving band). The transponder receives and processes these DME interrogation pulse pairs and triggers DME reply pulse pairs for use by the interrogating aircraft. In this manner, it is possible for up to 100 aircraft to obtain a visual indication of distance from the TACAN facility.

SECTION II

APPLICABLE DOCUMENTS

2.1 Military specifications, standards and publications. - The following documents, of the issue in effect on date of invitation for bids, form a part of this characteristic to the extent specified herein. When the requirements of these documents and this characteristic conflict, the requirements of this characteristic shall govern.

SPECIFICATIONS

Military

MIL-P-116D	Preservation, Methods of
MIL-E-4158	Electronic Equipment, Ground; General Requirements for
MIL-T-4207	Test Points; Ground Electronic Equipment
MIL-E-4682	Electronic Tubes and Transistors, Choice and Application of
MIL-T-4807	Test; Vibration and Shock, Ground Electronic Equipment (Requirements for)
MIL-E-4970	Environmental Testing, Ground Support Equipment, General Specification for
MIL-E-5272	Environmental Testing, Aeronautical and Associated Equipment, General Specification for
MIL-N-7513	Nomenclature Assignment and Nameplate Approval, Contractors Method for Obtaining
MIL-T-9107	Test Reports, Preparation of
MIL-D-9412	Data for Aerospace Ground Equipment, (AGE)
MIL-S-9548	Shelter, Electrical Equipment, S-118( )/TR and S-138( )/TR
MIL-F-14072	Finishes for Ground Signal Equipment
MIL-E-15090	Enamel, Equipment, Light-Gray (Formula No. 111)

MIL-R-26474 Reliability Requirements for Production, Ground  
Electronic Equipment

MIL-M-26512 Maintainability Requirements for Aerospace Systems and  
Equipment

MIL-I-26600 Interference Control Requirements, Aeronautical Equipment

MIL-W-27076 Workmanship Standards for Ground Electronic and  
Associated Equipment

MIL-D-27925 Dolly, Trailer, Front, V-266/TSQ-47; Dolly, Trailer,  
Rear, V-265/TSQ-47; Skid, Platform, Mx-4521/TSQ-47  
Ramp, Load, Vehicle, Mx-4792/G and ( ).

MIL-D-70327 Drawings, Engineering and Associated Lists

#### STANDARDS

##### Federal

595 Colors

##### Military

MIL-STD-129 Marking for Shipment and Storage

MIL-STD-130 Identification Marking of U.S. Military Property

MIL-STD-143 Specifications and Standards, Order of Procedure  
for the Selection of

MIL-STD-170 Moisture Resistance Test Cycle for Ground Signal Equipment

MIL-STD-242 Electronic Equipment Parts Selected Standards

MIL-STD-291A Standard Tactical Air Navigation (TACAN) Signal

MIL-STD-701 Preferred and Guidance Lists of Semiconductor Devices

MIL-STD-736 Unitized Equipment Design

MIL-STD-803 Human Engineering Criteria for Aircraft, Missile and  
Space Systems

MIL-STD-810 Environmental Test Methods for Aerospace and Ground  
Equipment

PUBLICATIONS

Air Force Logistics Command Manual

AFLCM 71-2            Preservation and Packaging, Methods and Instruction  
for Coding

(Copies of documents required by contractors in connection with specific procurement functions should be obtained from the procuring activity or as directed by the contracting officer)

SECTION III  
REQUIREMENTS

3.1 Preproduction testing.- This characteristic makes provision for preproduction testing as seen in Section IV.

3.2 Items to be furnished by the contractor.- One complete AN/TRN-( ) is defined as consisting of the principal groups and quantities thereof listed hereunder. All parts and other items necessary to provide the features, functions, capabilities, and performance required by this characteristic shall be incorporated and furnished, even though each specific part or item which is required is not individually identified or otherwise delineated herein. Similarly, all articles, services, processes and practices necessary to produce the equipment described herein, in accordance with the best engineering and workmanship practices as applied to similar USAF equipment, shall be provided and applied whether or not specified fully or are otherwise delineated in applicable documents.

TACAN Equipment	Quantity per Complete	Characteristic
<u>Group</u>	<u>AN/TRN-( )</u>	<u>Paragraph No.</u>
TRANSPONDER GROUP. . . . .	1 . . . . .	3.8.1
ANTENNA & ANTENNA CONTROL GROUP. . . . .	1 . . . . .	3.8.2
MONITOR GROUP. . . . .	1 . . . . .	3.8.3
LOCAL CONTROL & TRANSFER GROUP . . . . .	1 . . . . .	3.8.4
REMOTE CONTROL & SWITCHING GROUP . . . . .	1 . . . . .	3.8.5
TEST EQUIPMENT GROUP . . . . .	1 . . . . .	3.8.6
SHELTER GROUP. . . . .	1 . . . . .	3.8.7
ANTENNA ELEVATOR GROUP . . . . .	1 . . . . .	3.8.8

Each group furnished shall be complete to the extent that when properly interconnected with the groups listed above, all applicable requirements can be met without the need of other articles. The contractor shall furnish the number of complete sets of equipment, or principal equipment groups thereof, specified by contract, each in accordance with all applicable document requirements.

3.3 General requirements.- The requirements of specification MIL-E-4158 shall apply as a requirement of this characteristic. Specifications and standards for all materials and parts, and Government approval and certification of processes and equipment, which are not specifically designated herein and which are necessary for the execution of this requirement, shall be selected in accordance with Air Force - Navy Aeronautical Bulletin No. 143, except as provided in the following paragraphs:

3.3.1 Standardization.- AN and MIL standard parts shall be used wherever they are suitable for use and shall be identified by their part numbers. Commercial utility parts, such as screws, bolts, nuts, cotter pins, etc., may be used, provided they have suitable properties and are replaceable by AN or MIL standard parts without alteration, and provided the AN or MIL part numbers are referenced on the drawings and in the parts lists. In applications for which no suitable corresponding AN or MIL part is in effect, commercial parts may be used provided they conform to the requirements of this characteristic and to specification MIL-E-4158.

3.3.2 Electronic devices.- Tubes, transistors, diodes shall be chosen and the complement reported as outlined in MIL-E-4682.

3.3.3 Methods and techniques.- Methods and techniques employed to meet requirements of this characteristic shall insofar as is practical and consistent with other

requirements of the characteristic, be such as to provide the specified performance with the highest reliability and continuity of operation achievable within the present state-of-the-art. The complexity of the equipment and the number of adjustments and controls required shall be the minimum consistent with meeting all characteristic requirements.

3.3.4 Application of components not covered.- Where specific instructions are not given in this characteristic or applicable documents with respect to the derating and/or application of tubes, semiconductors and other components, the contractor shall be responsible for derating and/or providing such components as necessary to provide maximum reliability and stability. No component shall be operated at ratings or conditions in excess of those recommended by its manufacturer for the application and type of service.

3.3.5 Wiring and component arrangement.- The arrangement of units, components, connections and wiring shall be accomplished in such a manner that cross-talk and undesired coupling between circuits is neither actually nor potentially detrimental to the performance of the equipment. For purposes of this requirement, the term "potentially detrimental" shall be deemed to refer to a condition in which ambiguous or out-of-tolerance operation could occur due to the existence of cross talk when the equipment is operating normally. With the exception of tuned RF circuits, no arrangement is acceptable wherein the slight movement of components or wiring affects the operation or adjustment of a circuit. Similarly, no arrangement requiring the critical dressing of components or wiring to achieve proper operation is acceptable.

3.3.6 Non-selected parts.- All circuitry employing tuned circuits, such as RF stages, wide-band video and IF amplifiers, shall perform as specified in its respective unit or sub-unit involved without retuning or realignment following the replacement of any components thereof other than the inductor(s) and capacitor(s)



which constitute input, interstage or output coupling devices. These requirements shall be met when the characteristic tolerances of the components involved, including tubes and semiconductor devices, are within the upper and lower limits established by applicable specifications. Compliance with this requirement involving semiconductor and tube replacements may be demonstrated through the use of randomly selected semiconductors and tubes of the applicable types.

3.3.7 Shielding and isolation.- Adequate shielding and other means of isolation shall be provided wherever necessary to prevent significant changes in signal levels, waveforms, timing, tuning, or other adjustments under operating conditions with any combination of open access doors or withdrawn chassis.

3.3.8 Test points and connectors.- Each unit and subunit of the equipment shall have a sufficient number of test points and connectors, appropriately labeled and numbered, to provide for the examination of voltages, signal amplitudes, waveforms and timing and to provide for the connection of test equipment for adjustment and maintenance operations. Test points provided for voltmeter use only shall be jacks of the phone-tip type. Test points for the observation of waveforms may be of the phone-tip type or may be distinctive readily identifiable standoff terminals. Type BNC connectors shall be provided where connection is needed to test equipment having coaxial cable input and/or output connectors. All test points and connectors shall be accessible with adequate visibility and clearance from adjacent components and wiring to permit safe and convenient connection of cables and probes.

3.3.9 Metering.- In addition to metering specifically required under other sections of this characteristic, the output voltage and load currents of all DC power supplies shall be metered. Meter switching may be employed to satisfy this requirement.

Ruggedized meters shall be used throughout the system. All meters shall be shielded from stray fields or static charges, which would impair proper operation of the meters. Meter circuitry shall be designed to protect the meters from damage due to overload conditions.

3.3.10 Meter switching.- Meter switching shall be limited, in the case of current-indicating meters, to meter movements requiring one milliamperere or less for full-scale deflection, and further limited, for both current-indicating and voltage-indicating meters, to circuits having potentials of not more than 400 volts terminal to terminal or to ground (meter switched out or in).

3.3.11 Component protection.- The design of all equipment and circuitry shall be such as to provide protection of components (including tubes and semiconductor devices) against damage due to or resulting from loss of cooling airflow, voltage, or current. Fuses shall not be used in the load circuit of any power supply other than primary power.

3.3.12 Circuit breakers.- Circuit breakers shall be provided to control the incoming power. An indicator for each breaker shall be provided on the front panel (front panel of input/output power junction box preferred) to indicate the condition (ON or TRIPPED) of each circuit breaker. Each breaker shall be clearly marked as to its current capacity. Circuit breakers to protect at least the following circuitry shall be provided.

- (a) Convenience outlets;
- (b) Shelter blower (s);
- (c) Shelter lights;
- (d) Shelter electric heater;
- (e) Cabinet blowers;

- (f) Circuit breaker for each major cabinet and/or function;
- (g) External (GFE) air conditioner and/or heater power; and
- (h) At least two spare circuit breakers labeled "spare".

3.3.13 Operating temperature limitation.- When the equipment is operating normally at its maximum duty cycle and under conditions of the highest line voltage and ambient temperature specified under the service conditions, no component or material shall operate at or be subjected to temperatures exceeding those allowed by applicable specifications. In the absence of applicable specifications, the component or material manufacturer's recommended maximum ratings shall not be exceeded.

3.3.14 Service conditions.- The service conditions set forth below define the primary power, duty, and environmental conditions under which all specification requirements shall be met without readjustment of any controls, with exception to test equipment front panel controls. The primary power specified refers to the AC power mains available at the installation site for connection to the equipment.

Duty:

Test equipment: - - - - - Intermittent, attended.

All other equipment: - - - - - Continuous, unattended.

<u>System ambient temperature:</u>	<u>Operating</u>	<u>Non-operating</u>
Beacon and monitor antennas:	-40°C to +60°C	
Transponder Assemblies *	-28°C to +80°C	-62°C to +85°C
Oscilloscope *	-28°C to +65°C	-62°C to +85°C
All other test equipment *	-28°C to +80°C	-62°C to +85°C

\* The above equipment (excepting beacon and monitor antennas) shall meet the above local (temperature of the immediate ambient) ambient requirements.

Altitude

All equipment - - - - - 0 to 10,000 feet MSL 0 to 50,000 feet MSL

Ambient relative humidity

All equipment - - - - - 95 percent at +60  $\pm$  5°C

Primary power line voltage

All equipment - - - - - 120 volts  $\pm$  10 percent. The AN/TRN-( ) facility, including remote equipment and test equipment, shall withstand momentary line variations of  $\pm$  30 percent from the nominal voltages for a period of one second without part, component, or protective device failures. Completely normal operation shall be resumed after the transients have ceased.

Primary power line frequency

All equipment - - - - - 57 to 1000 cps

Primary power shall be provided commercially or by the military services and shall be voltage and frequency regulated at the specified frequency.

3.3.15 Primary power line voltage regulators.- Line voltage regulators shall not be provided as part of the AN/TRN-( ) equipment.

3.3.16 Equipment cabinetry and configuration.- With the exception of the antennas, all equipment shall be housed in cabinet type racks. The interior surfaces of all cabinets shall be smooth and free of any burrs or sharp edges, and finished with a light gray paint which enhances visibility.

3.3.16.1 Equipment cabinets.- Unitized construction of the cabinets shall be used to provide accessibility to the various units in the system. The various cabinets, drawers, and frame work shall be designed to provide sufficient strength to meet all environmental tests, yet be as light as possible. The dimensions of the cabinets shall be a function of the volume required to house the equipment and to satisfy human engineering requirements for optimizing the working conditions (space) of the maintenance technician. The arrangement of assemblies, sub-assemblies or parts within the cabinet shall, in general, be determined by the contractor but subject to USAF approval. The contractor, prior to fabrication of either assemblies or cabinets, shall submit to the USAF for approval copies of drawings showing details of proposed cabinets, the arrangement of assemblies, sub-assemblies, parts or components, and panel control or indicator arrangements. Three cabinets, two housing the transponders and one housing the test, monitor and control equipment (TMC), are preferred. The two transponder equipment cabinets shall be of the same external configuration and overall dimensions. The TMC cabinet shall be of the same configuration but may be of different dimensions. Provisions shall be made to mount each cabinet securely to the shelter so that it will withstand all environmental conditions without breaking loose from the shelter. Equipment performance requirements shall be met when the sides and back of the cabinets abut other cabinets and/or shelter walls. Cabinets shall not have access doors covering the front of cabinets.

3.3.16.2 Convenience outlets.- Duplex convenience outlets mounted in outlet boxes shall be provided at the bottom front of each cabinet. Outlets shall be of the parallel slot narrow yoke type with a third connector for grounding. The ground terminal shall be connected to the cabinet ground. Both duplex outlets shall be parallel connected.

3.3.17 Air filter.- Air intake and exhaust filter housings shall provide for the insertion and removal of filter elements without interrupting operation of the

equipment. Adequate exhaust air filter housings shall be provided with an exhaust duct adapter, if applicable, for shelter-cabinet integration. Air intake and exhaust openings shall be equipped with re-usable air filters.

3.3.18 Ventilation and cooling.- Each cabinet shall be equipped with a blower assembly (if required) and the system arranged to derive air at ambient temperature (inside or outside) through an intake filter at the bottom front or rear of the cabinet. Blowers shall be of the centrifugal type with one or two impellers and shall employ ball bearing type motors. Within each applicable cabinet, an air distribution duct system shall provide cooling of components of each unit and compartment primarily with air at ambient temperature, rather than with air heated through circulation over other cabinet installed units. Each duct aperture to a drawer chassis unit requiring cooling air shall have a shutter device which closes when the associated unit is partially withdrawn. Equipment units and components not amenable to cooling in the manner described shall be cooled by flushing air through the cabinet. Separate blower assemblies may be used for cooling the transponder final RF amplifier stage and oscilloscope, if required. All cooling shall be by means of a positive pressure system. When slide drawer units are not withdrawn, the exhaust of all air shall be through the top of cabinets wherever practicable. Where this is not practicable, the exhaust of cabinet air shall be through openings near the top of the cabinets. Provision shall be made to derive ambient air from, and exhaust the hotter cabinet air to, either the inside or the outside of the shelter at the discretion of the operator. Adaptors for attachment of flexible (external) air conditioner or heater ducting on both the shelter intake and shelter exhaust ports shall be provided.

3.3.19 Noise and vibration.- The application of all cooling system components shall be such as to minimize noise and vibration to the extent practicable.

3.3.20 Temperature rise limitation.- With the exception of the transponder compartment in which the final RF amplifier stage is installed, cooling shall be adequate to limit the air temperature rise within cabinets and compartments therein to a maximum of 10°C. The temperature rise in the transponder final RF amplifier compartment shall be minimized to the extent practicable; however, the operating temperature limitation of paragraph 3.3.13 shall apply as the governing factor. Temperature rise shall be determined by measurement of the difference in temperatures at the input side of air intake and exhaust filters or openings.

3.3.21 Inter-cabinet and inter-unit connectors.- Each cabinet shall be equipped with type AN connectors for the termination of inter-unit and inter-cabinet cabling. Suitable clamps shall be provided for each cable group.

3.3.22 Cable ducts.- Cable ducts for inter-cabinet cabling shall be provided.

3.3.23 Cabling.- The contractor shall furnish all cables, connectors and conductors required for inter-cabinet cabling between all units, subunits, subassemblies, and devices of the cabinet. Inter-cabinet cabling shall be separated from intra-cabinet cabling by separate forming, lacing and clamping. Coaxial cables, both intra-cabinet and inter-cabinet, shall be formed and laced separately from other conductors. Each coaxial cable shall be routed directly to the unit or subunit involved, rather than through intermediate cabinet terminating connectors.

3.3.24 Spare conductors.- Intra-cabinet cables between units and the associated cabinet connectors of paragraph 3.3.21 and each cable between cabinets, units and subunits thereof, shall include unused conductors totaling at least 20 percent of the number of conductors utilized, but not less than one spare conductor. The



spare conductor(s) provided shall be of the largest conductor size used in the cable exclusive of primary power wiring and shall have insulation as required for the highest voltage used in the unit or subunit. Spare conductors shall be terminated at the connectors and shall be identified as spares.

3.3.25 Unit construction.- Unitized construction shall be employed for all equipment mounted in cabinets; however, components such as power amplifiers, power supply transformers and filter capacitors, power amplifier mounting devices, blower motors, connectors and similar items may be mounted to cabinet structural members. In order to provide for modernization of equipment without the necessity of replacing complete units, a modular type of sub-unit construction shall also be employed wherever practicable. Circuitry performing basic functions, such as the IF amplifier, the video circuitry of a receiver, local oscillator and frequency multiplier stages, and the reference burst monitoring circuitry of a monitor unit shall be constructed as subunit assemblies. Where requirements governing physical characteristics (e.g., unit locations, sizes, features, and the functional grouping of panel controls and indicators) are not stated, the contractor shall place components and units in cabinets, and operational controls, indicators and other devices on panels, in an optimum arrangement and functional grouping which provide maximum operational and maintenance convenience to personnel. Controls which are not required for routine operation of the equipment shall be classed as maintenance adjustments and shall be located on unit and subunit chassis or printed circuit board if applicable.

3.3.25.1 Configuration of assemblies.- With the exception of components which may be mounted to cabinet structural members as specified in paragraph 3.3.25, all units and/or assemblies shall be of the drawer and panel type utilizing slide mounted chassis. The largest component mounting surface (for printed circuit boards

and other subunits) shall be in a plane parallel to the cabinet side. The orientation of chassis shall be such that the top of PCB's, solid state devices, transformer cases, etc., face the cabinet center area, and component terminals, PCB terminals, and wiring face the cabinet sidewall. Chassis shall have a readily removable cover plate on the wiring side and shall form a plenum chamber through which cooling air from the cabinet duct will enter, then pass through aperture adjacent to components requiring cooling. Slides shall permit the withdrawal of each unit or assembly individually and, to the extent necessary, to clear the cabinet front completely. A follower type cable arrangement shall permit continuous operation of the unit when the drawer is fully extended. All printed circuit boards shall be plug-in type with connectors mounted in the vertical plane. Printed circuit board extension adaptor cards shall be provided where applicable for maintenance and test purposes. All PCB extension cards (Z cards) shall be clearly marked and storage facilities shall be provided near or in the card rack in which it is utilized. Units and subunits other than printed circuit boards shall be plug-in type or readily removable through use of terminal blocks. With the exception of coaxial type inter-connections, terminals of all unit and subunit terminal blocks shall be covered with removable clear plastic strip barriers having round access holes above each terminal to permit the insertion of screwdriver blades or test leads.

3.3.25.2 Small components, such as resistors and capacitors which are not designed for chassis or PCB mounting, shall be mounted to insulating stand-off terminal lugs of the turret or bifurcated types attached directly to the unit, subunit or chassis in an orderly arrangement. Alternatively, such components may be mounted to turret or bifurcated terminal lugs attached to insulating panel boards. If necessary to provide unobstructed access to components, terminal lugs and wiring, such panel boards shall be hinged and provided with locking devices.

3.3.26 Fusing and fuse holders.- Fuse holders shall be front panel mounted and shall be of the blown fuse indicating type, utilizing neon glow lamps as indicators. At least one side of the primary winding of each power transformer shall be fused.

3.3.27 Relays.- All relays and/or contactors shall be of the plug-in hermetically-sealed type and shall be provided with suitable retainers. Each relay shall have its schematic diagram printed on its cover showing pin numbers, part number and other pertinent data. Each relay schematic shall be visible to the maintenance technician when the relay is plugged into its circuit correctly and the assembly is withdrawn from the cabinet. All relays shall be of a quality which will provide a life expectancy of at least 100,000 operations in the application and environmental conditions in which they are used.

3.3.28 Control adjustments. - All requirements for indications on dial scales associated with adjustable devices shall be met when the dial setting is approached from either direction.

3.3.29 Control locking devices.- Each adjustable control in the equipment, such as potentiometer shafts, cavity tuning rods, etc., shall be equipped with effective friction lock-nuts or clamps. Slug-tuned inductors and capacitors shall use jam-nuts for locking purposes; friction spring clamps or clips are not acceptable for uses other than providing smooth operation and minimizing backlash. Controls having positive-acting detents and all front panel controls used exclusively for test purposes are excluded from the above requirements. Glyptol or similar coatings shall not be used on any adjustable control.

3.3.30 Wafer switches.- Wafer-type switches shall employ ceramic type insulation exclusively and shall be of the highest quality.

3.3.31 Motors.- The design and quality of all motors shall be such as to provide a life expectancy in the respective applications of at least 50,000 hours of operation. The life expectancy is to be based on consideration of design factors rather than by life tests. The rotational speed of any motor used shall not exceed 1800 rpm.

3.3.32 DC power supplies.- Each transponder shall contain a high-voltage-power-supply and a low-voltage-power supply. The local control and transfer group, remote control and switching group, each test set, and each monitor shall contain individual power supplies.

3.3.32.1 Power source.- The equipment shall be designed to operate from a primary source of 115 volts, 57 to 1000 cps, as indicated in paragraph 3.3.14. The AN/TRN-( ) shall be capable of satisfactory continuous operation with maximum variations of  $\pm 10$  percent in line voltage. There shall be no instability in system performance when the input voltage is varied within the above limits. The equipment shall withstand momentary line variations of  $\pm 30$  percent from the nominal voltages for a period of one second without part, component, or protective device failures. Completely normal operation shall be resumed after the transients have ceased.

3.3.32.2 Voltage levels.- The number of DC voltages to be used in the design of the system shall be kept to a minimum. Exception to the use of DC voltages, other than the standard voltages listed below, shall require approval of the USAF.

6.3	75.0	250.0
12.6	100.0	300.0
24.0	150.0	450.0
45.0	200.0	1000.0

3.3.32.3 Capacity.- Each power supply shall support a load at least 20% in excess of maximum requirement. Voltage/current regulators shall be used as required to meet the terms of this specification.

3.3.32.4 Overload protection.- Automatic electronic overload protection and recovery circuitry shall be provided within each power supply.

3.3.32.5 Regulation and supply harmonics.- All power supplies shall be regulated to prevent sudden line changes from affecting system performance. Sufficient RF decoupling shall be included to prevent coupling of unwanted signals throughout the system. All frequencies which appear in the power supply units shall be suppressed sufficiently to prevent interference with TACAN control signals or other voltages which might result in improper operation.

3.3.32.6 Transformer insulation.- The DC resistance between input to output terminals and from both input and output terminals to case shall be in accordance with MIL-T-27A.

3.3.32.7 Transformers and inductors.- All audio, power, and pulse transformers and inductors shall conform to grade 4 or 5, class R, S, or T, life expectancy X, in accordance with MIL-T-27.

3.3.32.8 Transformer diagrams.- A schematic diagram shall be printed on the case of each transformer, or on a plate attached to the case. The diagram shall also be available in the technical manual. All other data pertinent to the transformer type shall be marked on the case as indicated in MIL-T-27.

3.3.32.9 Primary power circuits.- Primary power circuits shall not be directly grounded. Where capacitive type grounding is necessary, such capacitance shall be as small as possible. Leads from any primary power supply shall be protected against damaging overload between the service connection and any other part of the system, or unit, as applicable. The design of the power supplies shall permit optimum performance when either or neither side of the power supply line is grounded.

3.3.32.10 Front panel mounted facilities.- Each power supply specified in paragraph 3.3.32 shall have its own ON-OFF switch, protective fuses, spare fuses, and power-ON indicator lamp mounted on their respective front panels. It is not mandatory that spare fuses be mounted on test equipment front panels.

3.3.32.11 Line fuses.- Fuses shall immediately follow the power switch in the circuit and shall be mounted on the applicable power supply front panel. Spare fuse clips shall be provided as specified herein.

3.3.32.12 Transformer hum.- There shall be no transformer hum audible (to unaided human ear in normally quiet room) when the power supply is in operation and under normal load.

3.3.32.13 Electrical construction.- The active components used in the power supplies shall be completely solid-state devices. Thermionic devices shall be prohibited. Duplication of circuitry in the power supplies shall be used wherever possible to provide interchangeability.

3.3.33 Frequency control crystals.- All frequency determining crystals shall be of a quality equal to or better than that described in MIL-C-3098.

3.4 Aerospace ground equipment.- Aerospace ground equipment shall be scheduled, selected, designed, and documented in accordance with MIL-D-9412.

3.5 Selection of specifications and standards.- Specifications and standards for necessary commodities and services not specified herein shall be selected in accordance with MIL-STD-143.

3.6 Design and construction.- The AN/TRN-( ) shall be of solid-state, small size, and light-weight design, and shall be designed and constructed to satisfy the requirements herein specified without sacrificing system accuracy and deployment time.

3.6.1 Solid-state devices.- Solid-state devices shall be used throughout the system, except in areas where the state-of-the-art is such that solid-state devices are incompatible with the design requirements. In the higher RF power areas, if the contractor feels a need for the use of devices other than solid-state, such uses shall be subject to the approval of the USAF. No circuit designs shall be allowed which rely upon selection of semiconductor devices for specific parameters. For example, no circuits shall be allowed where transistors are selected for a narrower "beta" range than is specified for that particular transistor.

3.6.2 Subminiaturization.- Subminiaturization methods shall be used wherever possible without jeopardizing system performance. If the contractor can advantageously micro-miniaturize certain circuits, he is encouraged to do so, subject to the approval of the USAF.

3.6.3 Modularization and construction.- Throughout the system, modularized and/or printed circuit (P.C.) boards shall be used. Standardization of circuits shall



be used wherever possible to facilitate interchangeability of P.C. boards or modules. All major components shall be so constructed as to make P.C. boards, modules, and other internal parts readily accessible (see paragraph 3.3.25.1). P.C. boards shall be mounted in the vertical plane with the connector located on the wiring side of the chassis, where practical.

3.6.4 Reliability and maintainability.- The design of the equipment shall be such that the system will operate with a high degree of accuracy over long periods of time with a minimum maintenance requirement. Reliability of operation shall be considered of prime importance in the design and construction of the AN/TRN-( ). The contractor shall employ all methods possible in the process of design and construction which will insure quality and maximum reliability consistent with the state-of-the-art. The design shall include all possible features which will result in reliable and stable operation with minimum requirements for adjustment and alignment, minimum failure occurrence, reduced requirements for maintenance and simplified maintenance, thus reducing requirements for highly skilled personnel.

3.6.4.1 Mean-time-between-failure (MTBF).- The AN/TRN-( ) system shall be designed such that the MTBF shall be greater than 500 hours, with a confidence level of 90 percent or greater. The formula and procedure used for establishing this MTBF shall be: "System Reliability Prediction by Function", dated August 1963, prepared by ARINC Research Corporation (reference RADC-TDR-63-300).

3.6.4.2 Definition of failure.- Continuous operation and effectively unattended AN/TRN-( ) conditions shall prevail during MTBF tests for all equipment except test equipment. The AN/TRN-( ) is normally operated in the remote (automatic transfer/remote control) mode and MTBF tests shall be accomplished in the remote

(normal) mode of operation. Failures occurring within the AN/TRN-( ) system (except test equipment), including failures in common equipment or in both the primary and standby (duplicate) equipment, which results in automatic shut down of the AN/TRN-( ) system (whether it be caused by monitor, control, beacon or antenna equipment) and prevents successful system restart (reset) and return to "normal" service via the remote control unit within five minutes after initial, automatic shutdown and alarm, shall be deemed a failure. The AN/TRN-( ) shelter shall be effectively unattended during this five minute period. No local adjustments, switching, or corrective maintenance action shall be taken at the shelter during this period. Failures are not limited to actual component breakdown, but include circuit drift, etc. All monitor parameter alarm threshold limits shall be properly set prior to commencement of MTBF tests.

3.6.4.2.1 Definition of failure (test equipment).- The test equipment is normally operated intermittently and under attended conditions. Definition of a failure in the test equipment shall be the same as that specified in paragraph 3.6.4.2, where applicable, with the exception that the maintenance technician or operator may make test equipment front panel adjustments only (during any five minute failure period) to correct the failure. Test equipment readjustment periods shall be limited to five minutes.

3.6.4.2.2 Definition of interruption.- An interruption is defined as any condition where the normal operation of the system is altered, when no components are damaged and the system can be dialed back into normal operation (either remotely or locally), or where circuit breakers must be reset by the operator.

3.6.4.3 Mean-time-to-repair (MTTR).- The contractor shall exercise maximum effort to optimize maintainability, accessibility, simplicity, use of plug-in

units etc., with an objective of attaining an AN/TRN-( ) MTTR of not greater than one hour with a 90 percent probability that repair time will not exceed two hours. Both objectives will exclude time to acquire replacement parts and will be based on a repair crew of one skill level 7 airman with adequate AN/TRN-( ) TACAN maintenance training and experience.

3.6.5 Longevity (continuous operation).- The AN/TRN-( ) shall be designed and constructed to give optimum performance during continuous operation. Each item of equipment shall have a service life of not less than 45,000 hours (approximately five years of continuous operation) before wear out failure occurs or the equipment consistently fails to meet specified MTBF index, except as specified herein. The antenna drive unit if applicable, shall have a service life of at least 15,000 hours.

3.6.5.1 Longevity (intermittent operation).- The AN/TRN-( ) shall be designed and constructed to give optimum performance during intermittent operation and shall have a longevity period of not less than 17,500 hours based on an assumed operational use rate of 1,750 hours per year before wearout failures occur or the equipment consistently fails to meet its MTBF.

3.6.6 Human factors.- Alignment and operation of this facility shall be performed by, and be the responsibility of, one airman with a skill level of 5, under the general supervision of an airman with skill level 7. The design shall be such as to minimize the number of men required to install, align, maintain, and disassemble, for storage or shipment, the entire system. No operation shall require the services of more than two airmen. The design shall be in accordance with the human factors criteria of MIL-STD-803. An average time, not in excess of ten minutes, shall be

required for in-band channel change and short tune-up, including energizing the equipment for normal operation, by an airman of skill level 5.

3.6.6.1 Human engineering.- Arrangement of adjustments and readout devices on the various panels, and location of components (such as transmitter, receiver, test equipment, monitor, duplexer, and CTU) in their cabinets shall be governed by human engineering criteria. Where possible, the most used adjustments and readout devices shall be placed in locations readily accessible and convenient to the maintenance technician.

3.6.7 System compatibility.- The AN/TRN-( ), as a TACAN ground station, shall be capable of operating in conjunction with the latest versions of the AN/ARN-21 (A,B,or C), AN/ARN-52, AN/ARN-63, and AN/ARN-74, and other airborne TACAN equipments.

3.6.8 Special tools.- A minimum number of special hand tools shall be required for the airman to maintain this facility. All special tools required for maintenance shall be provided by the contractor as part of the AN/TRN-( ).

3.6.9 Construction/installation.- The design shall include all provisions for rapidly and accurately siting and aligning this facility. All equipment required for field assembly and disassembly shall be provided as part of the facility. All hardware required to mount and hold the various system parts in place during operation, storage, or shipment shall be provided as part of the facility. All equipment, which is assembled and disassembled in the field, shall be secured with captive hardware.

3.7 Performance.- This system shall provide accurate and reliable bearing, distance, and identity information within the requirements specified herein, and

shall be compatible with the airborne TACAN equipment listed in paragraph 3.6.7. It shall provide consistent and accurate distance information to a maximum of 100 aircrafts simultaneously. For performance tests of the DME capability, 3300 random interrogations per second shall be deemed equivalent to the required number of aircraft, approximately 95 percent of which are operating in the "track" mode and 5 percent in the "search" mode.

3.7.1 Electrical performance.- This system shall conform to all electrical requirements specified herein. It shall be designed and constructed such as to operate in accordance with the interference control requirements of MIL-I-26600.

3.7.2 Mechanical performance.- No operation performed by the operator while assembling, disassembling, or operating the system shall be of a hazardous nature.

3.7.3 Environment.- The system shall be constructed to meet all environmental requirements as specified in Section IV of this characteristic.

3.7.4 Operational performance.- The operational performance of the facility shall be as specified herein under any possible combination of the specified service conditions. The AN/TRN-( ) equipment shall receive, process, generate, and radiate signals and pulses in accordance with applicable paragraphs of this characteristic and/or applicable documents. The AN/TRN-( ) shall operate within all of the TACAN channel and frequency standards specified below.

3.7.4.1 Operating channels.- The transponder beacon shall provide the specified performance on any one of the following channels when the proper antenna array, RF generator, and frequency determining components are installed. The following respective interrogation and reply frequencies shall be as shown for each channel.

	INTERROGATION	REPLY		INTERROGATION	REPLY
	FREQUENCY	FREQUENCY		FREQUENCY	FREQUENCY
<u>CHANNEL</u>	<u>(Mc)</u>	<u>(Mc)</u>	<u>CHANNEL</u>	<u>(Mc)</u>	<u>(Mc)</u>
1	1025	962	27	1051	988
2	1026	963	28	1052	989
3	1027	964	29	1053	990
4	1028	965	30	1054	991
5	1029	966	31	1055	992
6	1030	967	32	1056	993
7	1031	968	33	1057	994
8	1032	969	34	1058	995
9	1033	970	35	1059	996
10	1034	971	36	1060	997
11	1035	972	37	1061	998
12	1036	973	38	1062	999
13	1037	974	39	1063	1000
14	1038	975	40	1064	1001
15	1039	976	41	1065	1002
16	1040	977	42	1066	1003
17	1041	978	43	1067	1004
18	1042	979	44	1068	1005
19	1043	980	45	1069	1006
20	1044	981	46	1070	1007
21	1045	982	47	1071	1008
22	1046	983	48	1072	1009
23	1047	984	49	1073	1010
24	1048	985	50	1074	1011
25	1049	986	51	1075	1012
26	1050	987	52	1076	1013

	INTERROGATION	REPLY		INTERROGATION	REPLY
	FREQUENCY	FREQUENCY		FREQUENCY	FREQUENCY
<u>CHANNEL</u>	<u>(Mc)</u>	<u>(Mc)</u>	<u>CHANNEL</u>	<u>(Mc)</u>	<u>(Mc)</u>
53	1077	1014	78	1102	1165
54	1078	1015	79	1103	1166
55	1079	1016	80	1104	1167
56	1080	1017	81	1105	1168
57	1081	1018	82	1106	1169
58	1082	1019	83	1107	1170
59	1083	1020	84	1108	1171
60	1084	1021	85	1109	1172
61	1085	1022	86	1110	1173
62	1086	1023	87	1111	1174
63	1087	1024	88	1112	1175
64	1088	1151	89	1113	1176
65	1089	1152	90	1114	1177
66	1090	1153	91	1115	1178
67	1091	1154	92	1116	1179
68	1092	1155	93	1117	1180
69	1093	1156	94	1118	1181
70	1094	1157	95	1119	1182
71	1095	1158	96	1120	1183
72	1096	1159	97	1121	1184
73	1097	1160	98	1122	1185
74	1098	1161	99	1123	1186
75	1099	1162	100	1124	1187
76	1100	1163	101	1125	1188
77	1101	1164	102	1126	1189



	INTERROGATION	REPLY		INTERROGATION	REPLY
	FREQUENCY	FREQUENCY		FREQUENCY	FREQUENCY
<u>CHANNEL</u>	<u>(Mc)</u>	<u>(Mc)</u>	<u>CHANNEL</u>	<u>(Mc)</u>	<u>(Mc)</u>
103	1127	1190	115	1139	1202
104	1128	1191	116	1140	1203
105	1129	1192	117	1141	1204
106	1130	1193	118	1142	1205
107	1131	1194	119	1143	1206
108	1132	1195	120	1144	1207
109	1133	1196	121	1145	1208
110	1134	1197	122	1146	1209
111	1135	1198	123	1147	1210
112	1136	1199	124	1148	1211
113	1137	1200	125	1149	1212
114	1138	1201	126	1150	1213

3.8 Details of components.- The components of each AN/TRN-( ), as listed in paragraph 3.2, shall be in accordance with the following requirements. All performance requirements shall be achieved under any possible combination of the specified service conditions.

3.8.1 Transponder.- The AN/TRN-( ) shall include one transponder group consisting of the following:

<u>Item No.</u>	<u>Qty</u>	<u>Description</u>	<u>(Reference)</u>
1	2	Transmitter Assembly - - - - -	3.8.1.1
2	2	Receiver-Coder Assembly - - - - -	3.8.1.2
3	2	Power Supply Assembly - - - - -	3.8.1.3
4	2	Cabinet Assembly - - - - -	3.8.1.4

3.8.1.1 Transmitter assembly.- The transmitter assembly shall consist of the following:

<u>Item No.</u>	<u>Qty</u>	<u>Description</u>	<u>(Reference)</u>
1	1	Oscillator Multiplier Unit - - - -	(3.8.1.1.2)
2	1	Driver Amplifier Unit - - - - -	(3.8.1.1.3)
3	1	Final Amplifier Unit - - - - -	(3.8.1.1.4)
4	1	Duplexer Unit - - - - -	(3.8.1.1.5)
5	1	Amplifier Modulator Unit - - - - -	(3.8.1.1.6)

3.8.1.1.1 Transmitter assembly performance requirements.- The transmitter assembly shall perform as follows:

3.8.1.1.1.1 RF power output deterioration.- The final amplifier and/or its cavity shall not deteriorate in power output below the levels of this specification, after proper tune-up is completed, and when the AN/TRN-( ) is subjected to the full range of specified service conditions.

3.8.1.1.1.2 Tuning and replacement.- The final amplifier cavity shall be continuously tunable (if tuning is required) by a single front panel knob, if possible, from 960 Mc to 1215 Mc. The cavity and/or final amplifier stage shall be so constructed and packaged that the final amplifier tube shall be rapidly replaceable. Adequate safety features shall be provided to insure that all hazardous potentials are removed during such replacement.

3.8.1.1.1.3 Directional couplers.- The circuitry associated with the final RF power amplifier stage shall incorporate the following bi-directional couplers for the observation of waveforms and the measurement of incident and reflected power:

- a. Input to the final power amplifier stage, labeled: "PWR AMP INPUT INCD" and "PWR AMP INPUT REFL"
- b. Output transmission line to the antenna transfer switch, labeled: "PWR AMP OUTPUT INCD" and "PWR AMP OUTPUT REFL"

Each bi-directional coupler shall be a two-port directional coupler; one port for incident power and one port for reflected power. The directivity of each port shall be at least 26 db. The nominal coupling factor for each port shall be chosen for proper integration with the built-in test equipment package specified. Coupler port terminals shall be type TNC and the incident ports, at least, shall be coupled to front panel mounted BNC test jacks. Where applicable, for test equipment integration and/or metering purposes, the incident (and reflected if applicable) RF signals shall be coupled back into the system via front panel mounted coaxial-solid-shield jumpers fitted with BNC connectors and chained to the front panel. The coupling factors (when determined) shall be within  $\pm 1$  db of the nominal coupling factor from 962 Mc to 1213 Mc. A calibration curve shall be provided for each port showing the coupling factor over the frequency range with an accuracy of  $\pm 0.25$  db. Input and output impedance shall be 50 ohms. The power amplifier output coupler may be located in the duplexer, the location of which shall be determined by the contractor.

3.8.1.1.1.4 Transmitter triggering.- The transmitter assembly shall be triggered by, and provide a properly shaped RF pulse from, each trigger gate and/or shaped pulse proceeding from the pulse gating/shaper sub-unit of the Coder Unit.

3.8.1.1.1.5 Isolation and tuning.- Sufficient isolation shall be provided in the transmitter assembly between stages and units or modules so that there shall be no "pulling" or instabilities during and after tuning, over the full range of specified service conditions. To provide spectrum information or other tuning indications for either the main or standby transponder, provision shall be made within the TMC equipment for switching the built-in test equipment package to either transponder without affecting TACAN service.

3.8.1.1.1.6 Spurious output.- There shall be no spurious or parasitic oscillations in any RF stage or circuit for any combination of tuning control positions with normal or subnormal excitation conditions.

3.8.1.1.1.7 Frequency stability and accuracy.- After proper tuning of the transmitter assembly, the frequency stability of the crystal-controlled oscillator circuitry and all stages of frequency multiplication and amplification in the multiplier, driver, and final amplifier units shall be held to the tolerance specified in paragraph 3.8.1.1.2.2 for a period of at least 30 operating days (720 hours). This frequency stability shall be maintained on all TACAN channels.

3.8.1.1.1.8 RF pulse spectrum.- The power contained in a 0.50 Mc band centered on frequencies 0.80Mc above and below the nominal reply frequency shall in each case be at least 55 db below the power contained in a 0.50 Mc band centered on the nominal reply frequency. The power contained in a 0.50 Mc band centered on

frequencies 2.00 Mc above and below the nominal reply frequency shall in each case be at least 60 db below the power contained in a 0.50 Mc band centered on the nominal reply frequency. Other bands of the spectrum, each measured in like 0.50 Mc bands, shall have lower levels of power therein than the adjacent band nearer the nominal reply frequency.

3.8.1.1.1.9 Spectrum control.- The output spectrum requirements shall be achieved through optimum design of transmitter and modulator circuits. The use of spectrum filters to achieve the desired TACAN RF pulse signal spectrum requirements shall not be allowed.

3.8.1.1.1.10 Transmitter output pulse signal.- The RF envelope of each pulse, as detected by the linear detector associated with the test equipment assembly, shall have a shape which falls within the following limits. The timing and sequence of pulses shall conform to the requirements specified under paragraph 3.8.-1.2.2, et al. The errors in measurement of the RF envelope due to the characteristics of the "linear detector" and associated circuitry shall not exceed the following:

Rise Time:	0.15 $\mu$ sec
Width:	0.15 $\mu$ sec
Decay Time:	0.15 $\mu$ sec

3.8.1.1.1.10.1 Pulse rise time.- The pulse rise time is defined as the time required for the leading edge to rise from 10 to 90 percent of its maximum amplitude, and shall be  $2.5 \pm 0.5$   $\mu$ secs.

3.8.1.1.1.10.2 Pulse top.- The instantaneous amplitude of the pulse top shall not, at any instant between the point on the leading edge, which is 95 percent of the maximum pulse amplitude, and the point on the trailing edge, which is 95 percent of the maximum pulse amplitude, fall below a value which is 95 percent of the maximum pulse amplitudes.

3.8.1.1.1.10.3 Pulse duration.- The pulse duration, as measured between the 50 percent maximum pulse amplitude points on the leading and trailing edges of the pulse, shall be  $3.5 \pm 0.5$   $\mu$ secs.

3.8.1.1.1.10.4 Pulse decay time.- The pulse decay time is defined as the time required for the trailing edge of the pulse to fall from 90 to 10 percent of its maximum amplitude, and shall be  $2.5 \pm 0.5$   $\mu$ secs.

3.8.1.1.1.10.5 Pulse amplitude variation.- Prior to amplitude modulation by the antenna of the composite RF pulse train, any pulse in a pair, other than the reference groups, shall not deviate from the average peak amplitude of the train by more than  $\pm 2.0$  percent. Any pulse of a pair within the north and auxiliary reference groups shall not deviate from the average amplitude of the same pulse pair by more than  $\pm 5.0$  percent. The average amplitude of any pulse pair within the north reference group shall not deviate from the average peak amplitude of the pulse train by more than  $\pm 2.0$  percent, and, correspondingly, within the auxiliary reference group by more than  $\pm 1.0$  percent. The recovery time following the pulse droop, shall not introduce an azimuth error of more than 0.2 degree for 135 cps modulation depths, created by the antenna, of 5.0 percent and greater. Compliance with the azimuth error requirement may be demonstrated by calculation of the 135 cps component by graphical analysis of the pertinent characteristics of the transponder beacon output pulse train over a period of 1/15 second. The requirements for droop control may be met through the use of adjustable, compensating circuitry.

The range of adjustment shall be adequate to permit minimizing the amplitude of the 135 cps component due to droop. The methods and techniques applied to provide the compensation shall provide the maximum practicable degree of freedom from the need of readjustment. Spurious amplitude modulation of the composite pulse train, other than described previously in this paragraph, shall not exceed one percent.

3.8.1.1.1.11 Spurious output.- At all frequencies from 27 Mc to 1660 Mc, but excluding the band of frequencies from 960 Mc to 1215 Mc, the spurious output as measured at the antenna transmission line connector at the output of the antenna transfer switch, shall not exceed -40 dbm Kc of receiver bandwidth. (For purposes of determining compliance with this requirement, measurement shall be made using a receiver having a 6 db bandwidth of not greater than 100 Kc.) The RF output level during the interval between occurrence of the desired pulse pairs shall be at least 80 db below the maximum power level contained in the transmitted pulse. In addition, the RF output level during the interval between pulses of each pulse pair shall be at least 50 db below the maximum power level of each pulse for not less than 1.0  $\mu$ sec. In each case, the measurement of the output signal level shall be made at the output side of the antenna transfer switch.

3.8.1.1.1.12 Output power control.- Means shall be provided for continuous adjustment of the transmitter power output from near zero to the maximum level required under paragraph 3.8.1.1.4. Preference shall be given to methods utilizing reduction of anode voltage and/or drive to the final RF amplifier, if this can be done without damage to any of the components. Use of RF attenuators or other lossy circuitry shall be permitted only if the preferred method is not feasible.

3.8.1.1.1.13 Transmitter pulse repetition rate.- In addition to the reference pulse groups, the transmitter shall be capable of transmitting a randomly distributed pulse repetition rate, which shall be maintained at  $2700 \pm 90$  pulse pairs per second.



3.8.1.1.1.14 Duty cycle.- The duty cycle shall be sufficient to meet the requirements of the pulse repetition rate and the requirements of pulse duration actually produced by the transmitter. These requirements shall be performed without exceeding any of the transistor or RF tubes' recommended ratings.

3.8.1.1.1.15 Receiver blanking provision.- Circuitry shall be provided, if necessary, to generate gates for blanking the receiver circuitry during transmission of the TACAN signal. This circuitry shall not introduce any stray or self-generated signals into the transmitter assembly that would interact with normal system operation.

3.8.1.1.1.16 RF decoupling techniques and radiation.- RF decoupling techniques shall be used throughout the transmitter circuitry to assure that no signal interactions occur. RF radiation shall be kept to the minimum required to provide the possibility of operation of the transmitter outside its cabinet without disturbing system operation.

3.8.1.1.1.17 Elapsed time indicators.- Each transponder shall be provided an elapsed time indicator providing time totalizing of 99,999.9 hours before recycling. The meter shall totalize the time when the transmitter anode voltage is applied.

3.8.1.1.1.18 Power control and switching.- Each transponder shall contain the relays and contactors required for internal primary power, time delay, supervisory, and overload control functions. The control of primary power to contactor solenoids shall be through, and subject to, the operation of the control and transfer equipment.

3.8.1.1.1.19 Time delay relays.- Means shall be provided to assure that power is applied in the proper sequence through the use of time delay and other supervisory controls as may be necessary. Time delay devices used for filament pre-heat timing (if applicable) in excess of a nominal one minute period shall provide recycling characteristics such that, in the event of primary power interruptions of 15 seconds or less, the time interval between restoration of primary power and the restoration of final RF amplifier voltage shall be reduced from the cold-start delay to the minimum interval consistent with adequate component protection. The use of thermal delay relays to achieve this characteristic is prohibited.

3.8.1.1.1.20 Primary power switches.- Circuit breakers shall be provided to disconnect primary power from each transponder. Separate toggle switches shall be provided to permit the turning off of individual power supplies.

3.8.1.1.1.21 Overload protection.- Overload protective devices shall be provided for each power supply furnishing DC anode voltages to transmitter and modulator high level stages. Overload devices, when tripped, shall be automatically reset as many as three times and then shall remain open upon being tripped the fourth time until reset by action of the control and transfer equipment. Resetting of overload devices shall occur between one and two seconds after tripping. The automatic reset shall be recycled to the normal position if operation within safe current limits is restored and the overload devices are not tripped four times within 12 seconds. Circuitry and components for the automatic reset functions shall be provided within each transponder. The removal of anode or bias voltages from components in consequence of overload protection action shall automatically remove voltages from other circuits if necessary to maintain safe conditions or operation within component ratings.

3.8.1.1.1.22 Metering and tuning.- A front panel mounted meter and function switch will be provided. The use of the meter function switch, in conjunction with the front panel meter, shall permit the operator to obtain a reading indicative of the performance of applicable stages of the transmitter assembly so that each stage requiring tuning during TACAN channel frequency change may be properly tuned via the front panel controls specified. The front panel meter and switch shall be provided for testing and coarse tuning of the transmitter assembly. The spectrum analyzer (paragraph 3.8.6) shall be used for fine tuning of the transmitter so that transmitter output energy will conform with the frequency spectrum requirements. The maximum time allowed for coarse tuning shall be 10 minutes. The maximum time allowed for fine (spectrum) tuning shall be 30 minutes. Metering shall be provided for modulator charging current, if significant.

3.8.1.1.2 Oscillator multiplier unit.- The oscillator multiplier unit shall include a crystal controlled oscillator assembly in an oven, if necessary, and frequency multiplying and buffer stages such that the output frequency represents the channel operating frequency of the transmitter. This unit shall supply sufficient energy to act as the receiver local oscillator signal and to drive the driver amplifier unit.

3.8.1.1.2.1 Oven.- The oven, if used, shall insure that the frequency of the crystal controlled oscillator is maintained within the required tolerance. If an oven is used, a front panel indicator lamp shall be incorporated to indicate the application of heater element power.

3.8.1.1.2.2 Crystal quantity and accuracy.- The number of crystals and related holders shall be kept to the minimum required to cover the 126 TACAN transponder channel frequencies. Circuitry shall be provided to permit fine frequency adjustment of all crystals utilized in the oscillator multiplier unit to a tolerance of

$\pm 0.001\%$  of the desired frequency. The frequency meter specified in paragraph 3.8.6 will be used to satisfy this frequency requirement. The oscillator circuitry shall maintain a required  $\pm 0.002\%$  frequency tolerance for a period of at least 30 days without further fine frequency tuning.

3.8.1.1.2.3 Emergency channel changing.- For use during emergency TACAN channel changing, when a new TACAN channel is selected, the selected channel frequency shall be held to a tolerance of  $\pm 0.004\%$ , without fine frequency tuning.

3.8.1.1.2.4 Channel in use indicator.- The number of the TACAN channel selected shall be plainly indicated on the front panel of the oscillator multiplier unit. The control knob or knobs for the channel change control shall also be readily accessible on this front panel.

3.8.1.1.2.5 Crystal storage facilities.- If individual field replacement type crystals are used in the oscillator multiplier unit, storage facilities shall be provided for spare crystal cartridges, which shall insure that they are easily available, if needed, and are protected from cracking, chipping, warping, or other damage.

3.8.1.1.2.6 Frequency range, tuning and detuning.- All frequency oscillator, multiplying, and/or amplifier buffer stages shall be designed to cover the desired frequency range of 960 Mc to 1215 Mc, using the minimum possible number of controls. All controls required of the oscillator multiplier unit for TACAN channel change will be available at the oscillator multiplier unit front panel. Tuning shall be straightforward and free of ambiguities. There shall be no detuning of the transmitter assembly, when withdrawing or swinging open, items 1, 2, 3, 4, or 5 of paragraph 3.8.1.1 from the main cabinet for inspection or maintenance purposes.

3.8.1.1.3 Driver amplifier unit.- The driver amplifier unit shall provide amplification, interstage isolation and filtering as required. Gated and/or shaped pulses from the amplifier modulator unit shall be applied to the driver amplifier unit. Amplification and filtering shall be such that the final amplifier stage can be driven to the maximum extent recommended for that stage. A single all-band driver amplifier unit is preferred if excessive adjustments are not required. All driver amplifier tuning controls requiring adjustment for any TACAN channel change shall be available at the driver amplifier unit front panel. If a high and low band driver amplifier is required, all electrical power shall be removed from the driver amplifier which is not active.

3.8.1.1.4 Final amplifier unit.- The final amplifier unit shall include a final RF power amplifier stage that provides a peak output power at the antenna side of the antenna changeover switch of at least 2,000 watts over the entire TACAN frequency band, at rated line voltage and at the maximum duty cycle. TACAN channel change tuning of the final amplifier unit, if required, shall be achieved via front panel control (s), if possible. The final RF amplifier stage of the transmitter shall employ a single stage which, in conjunction with its associated modulator and circuits, provides stable and reliable operation in accordance with the performance requirements.

3.8.1.1.5 Duplexer unit.- The final RF output signal shall be applied to the duplexer. The duplexer shall be of the passive type permitting simultaneous operation of the receiver transmitter (effectively). Duplexer controls shall be calibrated for the entire tuning range and shall have locking adjustments. Duplexer components may be physically located within the transponder group, as required, for greatest accessibility, optimum electrical performance, and system packaging.

3.8.1.1.6 Amplifier-modulator unit.- The amplifier modulator unit shall consist of a gate pulse modulator sub-unit and a shaped pulse modulator sub-unit.

3.8.1.1.6.1 Gate pulse modulator sub-unit.- The gate pulse sub-unit shall receive rectangular gate pulses from the pulse shaper sub-unit in the receiver-coder assembly and amplify them to the level needed to gate the transmitter power amplifier driver and/or final amplifier to the degree necessary to achieve the performance required of the AN/TRN-( ).

3.8.1.1.6.2 Shaped pulse modulator sub-unit.- The shaped pulse modulator sub-unit shall receive specially shaped pulses from the pulse shaper sub-unit in the receiver-coder assembly and amplify them to the level needed to pulse the transmitter power amplifier driver and/or final amplifier stages to the degree necessary to achieve the performance required of the AN/TRN-( ).

3.8.1.2 Receiver-coder assembly.- The receiver-coder assembly shall consist of:

<u>Item Nr.</u>	<u>Qty</u>	<u>Description</u>	<u>(Reference)</u>
1	1	Receiver unit -----	3.8.1.2.1
2	1	Coder unit -----	3.8.1.2.2

3.8.1.2.1 Receiver unit.- The receiver unit shall consist of the following sub-units:

<u>Item Nr.</u>	<u>Qty</u>	<u>Description</u>
1	1	Preselector Sub-unit
2	1	Directional Coupler Sub-unit
3	1	Low-Pass Filter Sub-unit
4	1	Mixer Sub-unit
5	1	Preamplifier Sub-unit
6	1	IF Amplifier & Video Sub-unit
7	1	Automatic-Rep-Rate-Control (ARRC) Sub-unit
8	1	Automatic-Receiver-Sensitivity-Control (ARSC) Sub-unit

3.8.1.2.1.1 Functional requirements.- The following are functional and specific requirements pertaining to the receiver unit.

3.8.1.2.1.2 Physical locations.- Physical locations of items 1 through 5 above shall be at the discretion of the contractor. Items 6 through 8 shall be grouped together and physically located in the receiver-coder drawer.

3.8.1.2.1.3 Receiver type.- The receiver shall be of a superheterodyne type employing CW output from the oscillator multiplier unit in the transmitter group as the crystal mixer local oscillator signal. The receiver shall contain a video detector and a decoder to distinguish interrogation pulses from interference or random noise.



3.8.1.2.1.4 Channel operating range.- The receiver shall be capable of receiving TACAN interrogation pulses with center frequencies ranging from 1025 Mc to 1150 Mc. With the exception of the preselector, the receiver unit shall require no retuning and the receiver requirements shall not fall below those specified herein when switching to any one of the standard 126 TACAN channels.

3.8.1.2.1.5 Receiver center frequency stability.- When the local oscillator frequency deviation with respect to on-channel reply frequency is  $\pm 0.002$  percent, the center frequency of the receiver pass band shall not deviate from the corresponding interrogation frequency by more than 60 Kc.

3.8.1.2.1.6 Receiver recovery time.- Within eight  $\mu$ secs after the reception of a DME pulse having any signal level up to 60 db above the specified receiver sensitivity level to desired pulse pairs, the threshold sensitivity to desired pulse pairs shall be within 3 db of the threshold sensitivity level which exists during the absence of other signals. The eight  $\mu$ sec interval shall be measured between the 50 percent maximum voltage amplitude points on the leading edge of the respective pulses. (The requirements of this paragraph shall be met when the repetition rate for the DME pulses is as high as 7200 normally shaped pulses per second, except that the pulse duration shall be 4.0  $\mu$ secs. For purposes of demonstrating compliance with this requirement, the test signals shall be synchronous.)

3.8.1.2.1.7 Shielding and grounding.- Proper shielding and grounding techniques shall be used throughout the system to prevent harmful ground loops, ground potentials, pick-up of stray signals, and harmful RF interference from the transponder transmitter. Shielding shall persist when the receiver is withdrawn from its cabinet for alignment test or maintenance purposes.

3.8.1.2.1.8 IF signal generator provisions.- Provisions for a 50 ohm matched

patching of the IF signal generator output to the IF amplifier input shall be provided for receiver maintenance and alignment purposes.

3.8.1.2.1.9 Receiver sensitivity.- The receiver shall respond to 60 percent of properly coded, on-channel interrogation pulses, having a peak power of -90 dbm at an interrogation rate of 1000 pulse pairs per second. The receiver sensitivity measurement shall be referenced to the antenna transmission line connector of the antenna transfer switch.

3.8.1.2.1.10 Receiver sensitivity variation with interrogation loading.- The receiver sensitivity shall not be reduced by more than 2 db with interrogation loading variation from 20 to 3300 interrogations per second.

3.8.1.2.1.11 Sensitivity at other pulse spacings.- Under conditions wherein the spacing of the pulses of a pair deviate from the design center value by  $\pm 0.5 \mu\text{sec}$ , the threshold sensitivity in the absence of other interrogations shall not be reduced by more than 1 db. The threshold sensitivity to DME interrogation pulse pairs deviating from the design center spacing value by  $\pm 3.0 \mu\text{secs}$  or more shall be reduced by at least 50 db.

3.8.1.2.1.12 Desensitization by adjacent channel interrogations.- The presence of adjacent channel interrogations at frequencies of  $\pm 900 \text{ Kc}$  from the on-channel interrogation frequency at levels up to 80 db stronger than the on-channel receiver sensitivity and at rates up to 1000 pulse pairs per second shall not reduce the on-channel receiver sensitivity by more than 3 db. Adjacent channel interrogation level measurement shall be made at the directional coupler connector at the receiver mixer sub-unit.

3.8.1.2.1.13 Sensitivity to adjacent channel interrogations.- For interrogation

signals at frequencies  $\pm$  900 Kc removed from the on-channel interrogation frequency and which have between pulse pair spacings of 12.0  $\mu$ secs, the receiver sensitivity in the absence of other signals shall be reduced by at least 80 db relative to the on-channel receiver sensitivity. The measurement shall be made at the directional coupler connector at the receiver mixer sub-unit.

3.8.1.2.1.14 Response efficiency.- The receiver and its associated video circuitry shall provide a response efficiency of not less than 70 percent to as many as 3300 interrogations per second at signal levels up to at least 75 db above the on-channel receiver sensitivity level, and in no case shall the response efficiency exceed 100%. The measurement shall be made at the directional coupler connector at the receiver mixer sub-unit.

3.8.1.2.1.15 Interference suppression.- The following requirements shall be met when signals at the frequencies referenced below are applied to the antenna transmission line connector at the antenna transfer switch. Incoming signals at the intermediate frequency shall be suppressed by at least 80 db. With the exception of signals within the desired pass band for the interrogation frequency in use, all other signals within the 960 to 1215 Mc band and at image frequencies shall be suppressed by at least 75 db. In addition, signals at frequencies between 1250 and 10,500 Mc shall be suppressed by at least 70 db. Frequencies from 1215 to 1250 Mc corresponds to the image frequencies for channels 65 to 100 and shall be attenuated by at least 75 db. In each case, response measurements shall be made at the output of the last IF amplifier stage prior to detection and decoding unless the receiver design is such that a different point ahead of the detector must be used to achieve valid measurements.

3.8.1.2.1.16 Output signals.- The signals at the receiver unit output terminal, providing triggers to the coder circuitry, shall consist of decoded DME interrogation

pulses and/or internally generated pulses automatically maintained at a total rate of  $2700 \pm 90$  pulses per second. These signals shall properly trigger the coder unit. The internally generated pulses shall be non-synchronous to all DME interrogation pulses resulting from interrogation levels up to at least 80 db above the on-channel receiver sensitivity level. The measurement shall be made at the directional coupler connector at the receiver mixer sub-unit. An auxiliary output jack (BNC) shall be provided on the receiver coder assembly front panel and shall provide a video signal, equivalent to that at the IF amplifier and video sub-unit output. This jack shall be labeled "INTERROGATION TEST."

3.8.1.2.1.17 Echo suppression.- Synchronous pulse signals occurring between the pulses of a direct path DME interrogation pulse pair, and which are also superimposed on the leading edge of the second pulse of the direct path pulse pair, shall neither result in the advancement or delay in decoding of the direct path pair by an interval greater than the allowable reply delay time variation nor result in a reply efficiency of less than 60 percent. These requirements shall be met when the RF input signal level of the direct path pulse pair is within the range of 10 to 75 db above the receiver on-channel sensitivity, and when the indirect path pulse signal has any level up to that of the direct path pulse pair. For purposes of establishing compliance with these requirements, the RF phase of the indirect path signals shall be continually changing with respect to that of the direct path signal. Additionally, the duration of the indirect path signal pulse shall be adjusted to within 8.0  $\mu$ secs of the direct path signal.

3.8.1.2.1.18 Receiver dead time.- The receiver dead time following the decoding of pulses, during which there will be no reply to subsequent interrogations in consequence of the dead time, shall nominally be 60  $\mu$ secs. The dead time gate width shall be continuously adjustable throughout the range of 50 to 200  $\mu$ secs.

3.8.1.2.1.19 Rejection of transponder output signals.- Gating pulses shall be applied to the receiver and its associated video circuitry in a manner such as to prevent retriggering of the transmitter due to the detection or introduction of transmitter signal energy into circuitry preceding the transmitter modulators. Such inhibiting shall end not later than termination of the dead time gate.

3.8.1.2.1.20 Interrogation overload.- Under interrogation overload conditions, wherein the number of decoded interrogation signals exceeds a nominal 2700 per second, the receiver sensitivity and the number of internally generated, non-synchronous pulses shall be automatically reduced as necessary to maintain the pulse rate to the coder circuitry within the limits of  $2700 \pm 90$  pulses per second. The rate shall be maintained when the number of interrogations is increased from zero to continuous interrogating (approximately 16,000 interrogations per second), or CW jamming. The requirements of this paragraph shall be met when the repetition rate for the DME pulses is varied from 20 to 16,000 interrogations per second and CW, and the interrogate signal level varied from receiver sensitivity threshold to 80 db above receiver sensitivity threshold. For purposes of demonstrating compliance with this requirement, the test signals may be synchronous and randomly varying in amplitude. The measurements shall be made at the directional coupler connector at the receiver mixer sub-unit.

3.8.1.2.1.21 Interrogation overload switching.- When, under interrogation overload conditions, the automatic receiver sensitivity control voltage reduces the receiver sensitivity by 1 db or more, an interrogation overload switch shall be energized. The switch shall have a pair of normally open contacts terminated for connection to the monitor signal generator units. The contacts shall be open circuited when the interrogation signal loading is 2400 pulses per second, or less.

3.8.1.2.1.22 Receiver bandwidth and stability.- The bandwidth of the receiver and the stability thereof, shall be such that the threshold sensitivity is not reduced by more than 3 db when the total receiver drift is added directly to an interrogation signal frequency deviation of 100 Kc.

3.8.1.2.1.23 Video circuit bandwidth.- The video circuitry following the IF to video detector (second detector) shall have a bandwidth adequate to preserve the rise time of the desired interrogation pulses, but shall afford attenuation of higher frequency components to a degree consistent with other performance requirements.

3.8.1.2.1.24 Receiver decoder.- The decoder circuitry shall decode and produce an output pulse from interrogation signal pulses occurring at spacings of  $12 \pm 0.5$   $\mu$ secs.

3.8.1.2.1.25 Second detector jack.- A BNC test jack shall be provided on the receiver-coder assembly front panel and shall provide a video signal equivalent to that at the output of the video detector after amplification and before limiting. This jack shall be labeled 2nd DET.

3.8.1.2.1.26 Preselector sub-unit.- An input preselector, tunable continuously throughout the range of interrogation frequencies, and having a 3 db bandwidth of not more than 10 Mc and not less than 5 Mc, shall be provided for the attenuation of off-frequency signals. Input and output impedance shall be 50 ohms. Unspecified characteristics of the preselector shall be chosen to satisfy system requirements.

3.8.1.2.1.27 Directional coupler sub-unit.- A directional coupler, for the injection of test interrogation signals from the Spectrum Analyzer Test Generator (see paragraph 3.8.6), shall be provided in the receiver input circuit between the preselector output and the receiver mixer input. The coupling factor shall



be  $10 \pm 1$  db from 1025 to 1150 Mc. A calibration curve shall be provided showing the coupling factor over the frequency range with an accuracy of  $\pm 0.25$  db. Directivity shall be at least 25 db. Input and output impedance shall be 50 ohms over the frequency range.

3.8.1.2.1.28 Low-pass filter sub-unit.- A low-pass filter shall be provided within the receiver unit and as part of the RF input circuitry. This filter shall provide approximately 70 db attenuation at frequencies between 1250 and 10,500 Mc. Input and output impedance shall be 50 ohms. Unspecified characteristics of the filter shall be chosen to satisfy system requirements.

3.8.1.2.1.29 Mixer and pre-amplifier sub-units.- The mixer and preamplifier may be separate sub-units or combined into a single sub-unit. Mixer output and IF shall be 63 Mc/second. Unspecified characteristics of the mixer and pre-amplifier shall be chosen to satisfy system requirements.

3.8.1.2.1.30 IF amplifier and video sub-unit.- The IF amplifier and video sub-unit shall contain the IF amplifiers, IF to video detector, video amplifiers, and decoder. The incorporation of gating, timing, and coder driving circuitry in this sub-unit is optional.

3.8.1.2.1.31 Automatic-rep-rate-control (ARRC) sub-unit.- The ARRC sub-unit shall function with other sub-units in the receiver unit, as required to satisfy the constant duty cycle receiver unit requirements during normal, overload, and/or CW jamming conditions.

3.8.1.2.1.32 Automatic-receiver-sensitivity-control (ARSC) sub-unit.- The ARSC sub-unit shall function with other sub-units in the receiver unit, as required to satisfy the constant duty cycle receiver unit requirements during normal, overload, and/or CW jamming conditions.



3.8.1.2.2 Coder Unit.- The coder unit shall consist of the following sub-units:

<u>Item No.</u>	<u>Qty</u>	<u>Description</u>
1	1	North/auxiliary burst sub-unit
2	1	Identity keyer sub-unit
3	1	Identity/equalizing pulse sub-unit
4	1	Timing/encoding and priority sub-unit
5	1	Pulse gating/shaper sub-unit
6	N/A	Metering and testing facilities

3.8.1.2.2.1 Coder and associated circuitry.- Circuitry associated with the coder shall accomplish gating, timing and coding of the distance reply, identity, and the north and auxiliary reference burst RF output signals produced by the transmitter. The following are functional and specific requirements pertaining to the coder unit.

3.8.1.2.2.2 North/auxiliary burst sub-unit.- The north/auxiliary burst sub-unit shall include two separate channels. One channel shall utilize the 15 cycle main reference trigger from the antenna to generate the main reference pulse group (or north burst). The other channel shall utilize the 135 cycle auxiliary reference trigger to generate the auxiliary reference pulse group (or auxiliary burst). The sub-unit shall also generate an azimuth reference precedence signal for priority gating purposes.

3.8.1.2.2.2.1 North and auxiliary reference burst timing.- The timing of north and auxiliary reference groups and the phase relationship of the identification signal pulse pair, each with respect to the others, shall be governed by the precision of the 1350 cps tone wheel generator. The north and auxiliary reference triggers furnished by the antenna shall be employed to establish the required gating and precedence.

3.8.1.2.2.2 North reference burst signal characteristics.- The north reference burst signal shall consist of a group of 12 pulse pairs. The spacing between the consecutive pulse pairs of a group shall be  $30 \pm 0.3$   $\mu$ secs.

3.8.1.2.2.2.3 Auxiliary reference burst signal characteristics.- The auxiliary reference burst group shall consist of a group of six pulse pairs. The spacing between consecutive pulse pairs of each group shall be  $24 \pm 0.25$   $\mu$ secs.

3.8.1.2.2.3 Identity keyer subunit. - The keyer shall be a solid-state device, which shall perform the functions listed below without exhibiting any form of incompatibility with the receiver-coder. Special consideration shall be given to insure that the keyer is electrically and mechanically compatible with the receiver-coder.

3.8.1.2.2.3.1 Identification signal pulse group timing.- The occurrence of identification signal pulse groups shall be governed by the operation of the facility identification keyer. Circuitry shall be provided to transmit station identity every 30 seconds  $\pm 10\%$ . International Morse Code dashes shall be 0.375 second  $\pm 10\%$ ; dots shall be 0.125 second  $\pm 10\%$ ; the time between dots and/or dashes shall be 0.125 second  $\pm 10\%$ ; between characters shall be 0.375 second  $\pm 10\%$ . The keyer shall be capable of providing a minimum of 21 dots, dashes, spaces, or any combination thereof. The time periods between dots and dashes shall be occupied by internally generated or DME pulses.

3.8.1.2.2.3.2 Identity code alteration.- Keyer characteristics shall be such that the identity code may be changed completely within one minute.

3.8.1.2.2.3.3 Precedence.- The dot and dash signals from the keyer shall provide the precedence establishing signal in the precedence circuitry.

3.8.1.2.2.3.4 Three-position switch.- A switch shall be provided to select any one of the following modes of operation:

- a. Disable mode: No transmission of identity pulses will occur.
- b. Operate mode: The identity code pulses shall be transmitted.
- c. Continuous mode: A continuous identity tone shall be transmitted for alignment and testing purposes.

3.8.1.2.2.4 Identity/equalizing pulse sub-unit.- The identity/equalizing pulse sub-unit shall receive a 1350 cps antenna tone wheel signal or, if applicable, a 1350 tone signal from the alternate 1350 cps tone generator. The sub-unit shall also receive keying signals from the identification keyer for identification keying and/or priority gating purposes.

3.8.1.2.2.4.1 Identification signal characteristics.- The identification signal shall consist of a series of paired pulses transmitted at a repetition rate of 1350 pulse pairs per second which are phase locked to the tenth harmonic of the 135 cps azimuth signal component. When the transponder is operating in the TACAN mode, the degree of alignment of the first pulse of each identity pair phase locked at a position 740  $\mu$ secs after the first pulse of each reference group (individually, but not simultaneously) shall be  $\pm 5 \mu$ secs. This accuracy may be attained through the use of a vernier continuously-adjustable delay line or a combination of one fixed delay line and one vernier continuously-adjustable delay line or delay line pick-off circuit, all located in the coder unit. Under normal (TACAN mode) conditions, the identification signal pulses shall be initiated by the output of the 1350 cps antenna tone wheel generator. In the normal (TACAN mode) operation, the identification pulses shall be synchronous with the north and auxiliary reference groups.

3.8.1.2.2.4.2 Equalizing pulse pair.- A pair of equalizing pulses shall be transmitted  $100 \pm 10$   $\mu$ secs after each identification signal pulse pair. The spacing shall be measured between the 50 per cent maximum voltage amplitude points on the leading edges of the first pulse of the respective pairs.

3.8.1.2.2.5 Timing/ encoding and priority sub-unit.- The timing/encoding and priority sub-unit receives the following signals:

- (a) Output of the IF amplifier and video sub-unit;
- (b) Outputs (including north and auxiliary gates for priority gating purposes and north and auxiliary bursts) of the north/auxiliary burst sub-unit;
- (c) Output of the identity/equalizing pulse sub-unit; and,
- (d) Keying signals from the identification keyer for identification keying and/or priority gating purposes.

3.8.1.2.2.5.1 Reply delay timing. - The timing/encoding and priority sub-unit shall provide means to adjust the reply delay time to any interval between the limits of 49 to 51  $\mu$ secs. The resolution shall be within 0.010  $\mu$ secs of the desired reply delay time setting within the specified range.

3.8.1.2.2.5.1.1 Reply delay time tolerance.- The reply delay time shall not deviate from any preselected nominal delay time by more than  $\pm 0.8$   $\mu$ sec for normal interrogation signals. This requirement shall be met for interrogation signal levels up to at least 75 db above receiver sensitivity level and at rates up to 3300 interrogations per second.

3.8.1.2.2.5.2 Encoding (pulse coding).- All transponder output pulses shall be coded in pairs with a spacing which shall be  $12 \pm 0.25$   $\mu$ secs as measured from the 50 per cent maximum voltage amplitude point on the leading edge of the first pulse to the corresponding point on the leading edge of the second pulse.

3.8.1.2.2.5.3 Priority of Transmission.- The order of precedence for transmission of the output signal pulses shall be:

- (a) North and auxiliary reference burst groups;
- (b) Identity and equalizing pulse groups;
- (c) Distance reply pulse pairs; and
- (d) Randomly occurring (squitter) pulse pairs.

Identity, equalizing and distance reply pulse pairs shall not be transmitted during reference burst groups, nor shall distance reply or squitter pulse pairs be transmitted during the transmission of identification signal Morse Code Groups.

3.8.1.2.2.6 Pulse gating/shaper sub-unit.- The pulse gating/shaper sub-unit shall accept the pulse pairs from the timing/encoding and priority sub-unit and convert them into gating pulses and shaped pulses as well as provide proper timing as required by the transmitter assembly.

3.8.1.2.2.7 Metering.- A meter and meter switch shall be mounted on the receiver coder unit front panel. The following circuits shall be metered through the application of meter switching.

- (a) Mixer crystal currents, if applicable;
- (b) Automatic-rep-rate-control (ARRC) voltage;
- (c) Automatic-receiver-sensitivity-control (ARSC) voltage;
- (d) Receiver bias voltage; and,
- (e) Any tuning indication required for other than IF alignment;

3.8.1.2.2.8 Test points.- As a minimum number of test jacks the following BNC test jacks shall be mounted on the receiver-coder unit front panel. (These auxiliary output test jacks shall provide signals, equivalent to that at the point in the circuit being tested. Shorting out of the individual test jacks shall not deteriorate system performance.

- (a) Second detector output, labeled: "2nd DET";
- (b) IF amplifier and video sub-unit output, labeled: "INTERROGATION TEST"; and,

(c) Video output to decoder, labeled: "CODER INPUT".

A readily accessible BNC test point shall be provided on the IF amplifier and video sub-unit and shall provide an IF signal, equivalent to that at the input to the IF-to-video detector for IF strip alignment and test purposes. It shall be possible to terminate this test point with one megohm impedance or higher without affecting circuit characteristics. The oscilloscope specified is capable of displaying up to 65 Mc. Each unit and sub-unit of the equipment shall be in accordance with paragraph 3.3.8.

3.8.1.3 Power supply assembly. - Each transponder shall contain a low voltage power supply assembly and a high voltage power supply assembly (see paragraph 3.3.32). It is preferred that these power supply assemblies be physically located near the bottom of the applicable transponder equipment cabinet. Drawer and panel slide mounted chassis shall be provided for each power supply assembly as specified in paragraph 3.3.25.1 It is intended, but not mandatory, that the high voltage power supply provide DC voltages for the transmitter assembly only and the low voltage power supply provide DC voltages for the receiver-coder assembly and the low voltage requirements of the transmitter assembly. Metering of all voltages and currents, as well as front panel inductors and other features, shall be provided as specified in Section I of this characteristic.

3.8.1.4 Cabinet assembly.- The transponder cabinet assembly shall be as specified in Paragraph 3.3.16.1 of this characteristic.

3.8.2 Antenna and antenna control group.

(Not required by Contract AF 19(628)-3263)

### 3.8.3 Monitor group.-

NOTE: It should be indicated that this portion of the characteristic, involving the monitor, is primarily geared to the capabilities of the monitor which was vendor provided for Contract AF 19(628)-3263. Other monitor information, which is available in the TACAN field, and which reflects some of the latest TACAN thinking, has been provided herein; however, this monitor characteristic, as far as enhancing flying safety is concerned, is lacking in scope.

Features and areas lacking in the vendor provided monitor follow:

(a) Lack of monitoring the following significant critical parameters:

- (1) Identity five-second monitor
- (2) Identity forty-five second monitor
- (3) Identification signal (pulse spacing) monitor.
- (4) Equalizing pulse pair (pulse spacing) monitor.

(b) Inadequate stability of alarm point resolution.

3.8.3.1 General.- The AN/TRN-( ) shall contain one transponder monitor group, and the monitor group shall consist of two monitor units. Both monitor units shall be physically located in the lower portion of the test monitor and control (TMC) equipment cabinet. The monitor equipment described herein shall continuously and



automatically monitor nine performance parameters of the transponder beacon and the signal radiated by its antenna. Digital techniques shall be used wherever feasible to insure stable, accurate, and reliable monitoring. Through the local control and transfer group (paragraph 3.8.4), the monitors shall exercise supervisory control over facility operation in a fail-safe manner.

3.8.3.2 Equipment to be furnished by the contractor.- This characteristic requires that two complete monitor units be furnished with each AN/TRN-( ) TACAN facility. Each monitor unit shall be in accordance with the applicable requirements of Section I.

3.8.3.3 Design, functional and performance requirements.- Each monitoring unit shall provide the required fault threshold points, the sensing and indication of faults, and the determination and maintenance of an acceptable level of TACAN equipment performance characteristics. The performance of each monitor shall be independent of the connection of a second monitor. Each monitor shall be complete within itself, including power supply, and shall provide the basic functions indicated in accordance with the requirements of subsequent paragraphs:

3.8.3.3.1 Monitor unit installation and arrangement.- Monitor units, other than the antenna, shall be installed side by side in the lower portion of the TMC (center) equipment cabinet. The monitor antenna unit may be installed at any distance up to 50 feet from the AN/TRN-( ) antenna and at a positive elevation angle from approximately 0 to approximately six degrees (depending upon monitor antenna distance from the TACAN antenna) with respect to the bottom of the central array. The RF cable from the monitor antenna provided by the contractor will consist of 100 feet of RG-223/U with TNC connectors, and will connect to a low pass filter and 50 ohm power divider located in the TMC cabinet. The monitor unit described herein shall include

the interrogation signal generator functions, the DME monitor functions, the azimuth monitor function, the monitor receiver functions and the monitor power supply.

3.8.3.3.2 Monitor input and output signal connections.- All RF input and output signal connections to the monitoring units shall be terminated at the TMC patch panel. The monitoring of all azimuth signal components shall be performed with signals derived from the monitor antenna. All other monitoring functions shall be accomplished through the injection and sampling of signals through the directional couplers associated with the antenna transfer switch.

3.8.3.3.3 Operating frequencies.- The monitor equipment shall provide the specified performance on any one of the channels listed under Section III, paragraph 3.7.4.1 when the proper crystal is installed.

3.8.3.3.3.1 Frequency accuracy and stability.- The output frequency of all frequency determining oscillators shall be within  $\pm 0.002$  percent of that frequency used to produce the exact frequencies required for any of the specified channels. Facilities to check and adjust this frequency shall be provided as specified in paragraph 3.8.6.2.4.

3.8.3.3.4 Range of RF input signal levels.- All monitor performance requirements shall be met under conditions wherein:

- a. The RF peak pulse power level from the monitor antenna (averaged over the modulation envelope) is within the range of -10 to +5 dbm as measured at the TMC cabinet patch panel connector; and
- b. The RF peak pulse power level from the antenna transfer switch directional coupler providing input signals to the transponder monitoring units is within the range of 24 to 45 dbm peak as measured at the referenced patch panel connector.

The power levels of (b) above are based on nominal coupling factors of 24 db between the TACAN antenna or dummy load transmission line and the patch panel connector.

3.8.3.3.5 Primary power line voltage regulators.- All applicable performance requirements shall be met without the use of external line voltage regulators.

3.8.3.3.6 Fault sensitive devices and associated circuitry.- Fault sensitive devices, controlled by the different fault sensing circuits of the monitor, shall be provided for the control of the specified fault indicators and for the control of the master alarm relay circuitry. If fault relays are used, they shall be de-energized under fault conditions in order to permit recovery from a fault condition with a minimum differential in the level of a control signal.

3.8.3.3.7 Front panel mounted indicators.- The monitor unit front panel shall contain an identity code light, an identity tone phone jack, monitor parameter alarm indicators, a master alarm light, diode oven light(s), blower fuse indicators, a power ON-OFF light, and an RF attenuator (db).

3.8.3.4 Interchangeability.- Each of the monitor units furnished hereunder for mounting in the TMC equipment cabinet shall be directly interchangeable in all respects.

3.8.3.5 Monitor unit additional requirements.- The monitor unit shall meet the requirements of the following sub-paragraphs.

3.8.3.5.1 Single or dual monitor functions.- Each monitor unit shall be designed to function independently as a single monitor unit, or together with a second

(identical) monitor unit as required to support the AN/TRN-( ) facility. It shall also be possible to operate a single monitor unit with two transponders in the automatic/remote mode.

3.8.3.5.2 Interrogation signal generator sub-unit.- The signal generator sub-unit shall provide DME interrogation and timing reference signals for the relevant functions of the transponder monitor unit.

3.8.3.5.2.1 Operational modes.- The interrogation signal generator sub-unit shall produce either CW or pulsed RF output signals in accordance with the mode of operation selected by a rotary function selector switch as follows:

- a. Position 1 (CCW) shall provide unmodulated CW output signal for an adjustment of the RF output signal to a reference calibration level. The average RF power meter in the test equipment group (paragraph 3.8.6) shall be used for this purpose.
- b. Position 2 (center position) shall switch off all signal generator RF output and provide for zero setting of the test equipment average power meter.
- c. Position 3 (CW) shall provide for normal monitoring operation with internally timed and generated interrogation pulse pairs occurring at a repetition rate of approximately 30 pulse pairs per second. The spacing between pulses of a pair shall be  $12 \pm 0.5$   $\mu$ secs, measured as specified in paragraph 3.8.3.5.2.3. A pulse spacing vernier adjustment shall be provided for pulse spacing calibration utilizing the test equipment group.

3.8.3.5.2.2 RF output signals.- Under conditions of pulse operation, the interrogation signal generator shall produce output signals conforming to the requirements

of paragraph 3.8.1.1.1.10.

3.8.3.5.2.3 Pulse coding.- When the interrogation signal generator sub-unit function selector switch is indexed to position 3 (CW), pulses shall be coded in pairs with a spacing, as measured between the 50 percent maximum voltage amplitude point on the leading edge of the first pulse to the corresponding point on the leading edge of the second pulse, of  $12 \pm 0.5$   $\mu$ secs.

3.8.3.5.2.4 Pulse power variation.- The difference in amplitude between the pulses of a pair shall not exceed 0.5 db.

3.8.3.5.2.5 RF pulse spectrum.- The RF spectrum of the interrogation pulse signal shall be such that at least 90 percent of the energy in each pulse shall be within a 0.5 Mc band centered on the nominal channel interrogation frequency.

3.8.3.5.2.6 Amplitude modulation.- Amplitude modulation of the RF output signal by other than the desired pulses shall not exceed three percent.

3.8.3.5.2.7 Timing reference pulse.- For reply delay time monitoring, the interrogation signal generator shall provide a timing reference output pulse coincident within  $\pm 0.05$   $\mu$ sec of the 50 percent maximum voltage amplitude point on the leading edge of the second RF pulse of each interrogation pulse pair.

3.8.3.5.2.8 RF output level calibration.- The average RF power meter and oscilloscope specified in the test equipment group (paragraph 3.8.6) shall be used for setting the CW and pulse RF power to a reference calibration level.

3.8.3.5.2.9 Automatic level control (ALC).- The RF power shall be automatically maintained at the calibration level under all conditions of pulsed operation. Failure of the ALC system to regulate the RF output to within  $\pm 2.0$  db of the calibration level shall result in a fault condition. Any deviation from the reference calibration level under pulsed operation shall be indicated by a front panel meter. Internal controls shall be provided for meter zero setting and for setting the CW and pulse RF levels to their proper calibration levels when the function selector switch is in the CW, OFF and PULSE positions.

3.8.3.5.2.10 RF output level and accuracy.- The RF output level shall be continuously variable between the limits of 0 dbm and +100 dbm as measured in a 50 ohm resistive load at the TMC patch panel connector. The output attenuator shall have an essentially linear scale calibrated in increments of 1 db over the specified range. After calibration, the RF output level over the range of interrogation frequencies shall be within  $\pm 1.0$  db of the level indicated by the attenuator dial when measured in a 50 ohm resistive load at the TMC patch panel connector.

3.8.3.5.2.11 Attenuator power handling capability.- The RF output attenuator shall be capable of continuously dissipating, without damage or loss of calibration an average power of up to 2 watts, a peak power of up to 500 watts.

3.8.3.6 DME/azimuth monitor sub-units.- In conjunction with the signal generator and monitor receiver sub-units, the parameter monitor sub-units monitor nine significant properties of the TACAN beacon performance.

3.8.3.6.1 Monitoring.- Characteristics pertaining to the nine parameters monitored are described in the following paragraphs.

3.8.3.6.1.1 Receiver sensitivity.- The fault threshold point for receiver sensitivity monitoring shall be reached when the number of decoded transponder pulse pairs, which are synchronous to the monitor interrogations, decreases to 60 percent  $\pm$  1 count, or less, of the number of monitor interrogation pulse pairs per second. A fault shall not exist when the reply efficiency is 65 percent or more. During the transmission of identification signals, operation of the receiver sensitivity fault relay shall be inhibited.

3.8.3.6.1.2 Transponder reply delay time.- The fault threshold point shall be reached when the transponder reply delay time deviates from the preset nominal delay time by  $\pm$  0.8 ( $\pm$ 0.1)  $\mu$ sec or more. The specified performance shall be provided under all conditions of operation. Operation of the reply delay time fault sensing devices shall not occur during the transmission of identification signals. Means shall be provided for adjustment of the reply delay time aperture position, with respect to the timing reference pulse of paragraph 3.8.3.5.2.7, over the range of at least 49 to 51  $\mu$ secs.

3.8.3.6.1.3 Transponder output pulse spacing.- A fault condition shall exist when the spacing of the constituent pulses of transponder output pulse pairs deviate from 12  $\mu$ secs by 0.5 ( $\pm$ 0.1)  $\mu$ sec or more.

3.8.3.6.1.4 Transponder pulse rate.- Transponder pulse rate is defined as the total transponder output count less the north and auxiliary reference bursts (2700  $\pm$  90 pulse pairs per second). This count occurs at a random rate and includes DME replies. The fault threshold point for transponder pulse rate shall be reached when the pulse rate deviates from 2700 pulse pairs per second by an amount equal to or more than the tolerance limits set. Pulse rate ( + and - )



alarm threshold point resolution shall be  $\pm 1$  pulse per second. Fault threshold points shall be re-settable as desired in one pulse per second steps ( $\pm 90$  pulse pairs per second nominal). Actual pulse rate readout shall be readily attainable utilizing the test equipment (see paragraph 3.8.6) without external patching. Readout accuracy shall be  $\pm 1$  count per second. It shall be possible and simple to convert pulse-rate monitoring circuitry to monitor transponder total pulse count ( $3600 \pm 90$  pulse pairs per second) without losing accuracy or readout features specified under pulse rate.

3.8.3.6.1.5 Transponder power output monitoring.- The power monitoring circuitry shall respond to the received level of pulses radiated by the TACAN antenna as averaged over the modulation envelope. A fault threshold control on the chassis shall provide a fault threshold point at a power level within the range of -2 to -5 ( $\pm 0.5$ ) db relative to any initial input signal level within the range referenced in paragraph 3.8.3.3.4 (a) hereof. A maximum increase in input signal level of 0.5 db relative to the fault threshold point shall end the fault indication. The signal output level to azimuth monitor circuits shall not be affected by adjustment of the power threshold level control.

3.8.3.6.1.6 Identification signal monitoring.- The identity monitoring circuitry shall detect the transponder identification signal and shall illuminate a front panel mounted light and provide an audio tone to a front panel mounted phone jack, in synchronism with the international Morse code identification signal being transmitted.

3.8.3.6.1.7 Antenna rotation rate monitoring.- A fault condition shall exist when the antenna rotation rate deviates from 900 rpm (15 cps) by an amount equal to or more than the tolerance limits set; rotation rate ( + and - ) alarm threshold

point resolution shall be  $\pm 0.1$  degree per second. Fault threshold points shall be re-settable (programmed) as desired in 0.1 degree per second steps ( $\pm 0.8$  degrees per second (900 rpm  $\pm .25$  percent nominal). A deviation in an antenna rotation rate of  $\pm 0.2$  percent or less (from 900 rpm) shall not result in a rotation rate fault.

3.8.3.6.1.8 North reference group monitoring.- The fault threshold point for the north reference group shall be reached when the number of pulse pairs in each reference group is reduced from 12 pulse pairs to either 10 or 11 as determined by circuit programming. The fault threshold point for spacing between the corresponding pulses of consecutive pairs shall be reached when the spacing deviates from 30  $\mu$ secs by more than  $\pm 1.0$  ( $\pm 0.5$ )  $\mu$ sec.

3.8.3.6.1.9 Auxiliary reference group monitoring.- The fault threshold point for the auxiliary reference groups shall be reached when the number of pulse pairs in each group is reduced from six pulse pairs to either four or five, as determined by circuit programming. The fault threshold point for spacing between the corresponding pulses of consecutive pairs shall be reached when the spacing deviates from 24  $\mu$ secs by more than  $\pm 1.0$  ( $\pm 0.5$ )  $\mu$ sec.

3.8.3.6.1.10 Azimuth error monitoring.- Azimuth error monitoring shall be limited to utilization of the 135 cps azimuth signal data. A continuously variable front panel control shall provide for monitoring the azimuth error at a selected radial within any 40 degree sector and shall provide for the establishment and periodic checking of fault threshold points through adjustment of a calibrated dial. The dial shall be calibrated in increments of 0.1 degree through a range of 40 degrees and shall be readable to 0.05 degree.

3.8.3.6.1.10.1 Error indication and accuracy.- The monitoring circuitry shall detect deviations in azimuth with respect to a reference radial on which a monitor antenna is installed. The detected deviation shall be indicated by a front panel readout capable of indicating plus and minus deviations from 0 to 2.5 degrees full scale. Over a range of plus and minus 2.5 degrees, with respect to any selected reference radial, as indicated by the front panel dial of paragraph 3.2.11.3, the indicated deviation shall be accurate to within  $\pm 0.1$  ( $\pm 0.1$ ) degree. Controls shall be provided for setting the fault threshold points to any deviation between the limits of .4 and 2.0 degrees.

3.8.3.6.1.10.2 Cyclical error.- When the input signal to the monitor consists of a composite signal corresponding to that radiated by a TACAN antenna, the cyclical error throughout 40 azimuth degrees shall not exceed  $\pm 0.1$  ( $\pm 0.1$ ) degree as referenced to the azimuth represented by the input signal, exclusive of the metering error of paragraph 3.8.3.6.1.10.1. These requirements shall be met when the TACAN antenna rotation rate is 900 rpm.

3.8.3.6.1.10.3 Azimuth calibration.- An internal azimuth calibrator shall be provided for establishing and periodically checking the accuracy of the 135 cps azimuth error monitoring circuitry. The calibration signal shall consist of a video simulation of the composite TACAN signal received by a monitor antenna except that the 15 cps modulation component need not be provided. The 135 cps modulation component shall be available from an external source (not required to be furnished under this specification) providing an amplitude of 5 volts  $\pm 10$  percent across 600 ohms. The component TACAN pulse train signal may consist of the transponder output pulse train demodulated by the transponder monitor unit. The calibration signal shall establish a reference azimuth corresponding within  $\pm 0.1$  ( $\pm 0.1$ ) degree to a north radial from the station. The front panel shall have

a switch providing for switching between the normal monitoring and calibration modes of operation and an input BNC connector for the 135 cps signal. Means shall also be provided for field calibration and checking of the cyclic error or paragraph 3.5.3.6.1.10.2 using the pulse counter which is provided as part of the test equipment.

3.8.3.6.2 Monitor power supply.- The monitor power supply subunit shall provide power to all other monitor subunits. A front panel switch shall control the application of primary power to all monitor subunits. A meter and meter selector switch shall be provided on the front panel for the required DC power supply voltage and current metering. Each monitor unit shall contain its own power supply subunit.

3.8.3.6.3 Monitor antenna subunit.- It is required that the metallic dimensions of the monitor antenna and antenna support assembly be held to a minimum consistent with meeting other electrical and environmental requirements. The monitor antenna shall be provided with connectors, required coaxial cable, and versatile antenna support/mounting assembly. The antenna impedance shall be 50 ohms nominal. TNC weather proof connectors and RG-223/U type cable shall be provided.

3.8.3.6.3.1 Monitor antenna support assembly.- The monitor antenna support/mounting assembly shall be sufficiently versatile to allow for vertical and horizontal physical placement of the antenna element. Vertical adjustment shall be from -6 degrees to +6 degrees relative to the bottom of the central array. Horizontal adjustment shall be 360 degrees at any vertical adjustment setting. The monitor antenna shall be mounted in such a manner as to be sufficiently rigid so that it will not move more than 0.05 degree in the horizontal plane with respect to the TACAN antenna throughout the operating environment. The positioning of the monitor antenna shall

be such that it will not adversely effect the radiated pattern transmitted to or received from aircraft within the TACAN range of operation. The necessary inter-connecting cable between the antenna and the shelter shall be provided by the contractor. Installation, disassembly and storage of the monitor antenna system shall be simple and designed such that installation and adjustment may be accomplished in 10 minutes or less by one qualified maintenance technician.

3.8.3.6.4 Environmental performance.- Means shall be provided which effectively prevent the accumulation of snow, ice, and slush on critical surfaces of the antenna. The means shall be effective under conditions of snow, ice, or sleet precipitation, accompanied simultaneously by winds up to 30 knots, impinging on the antenna from any radial direction at any temperature from near freezing to -40° C. Any loss of signal level in consequence of precipitation under the conditions referenced shall not exceed 1 db.

3.8.3.6.4.1 Antenna heaters.- In the event that antenna heaters are utilized to satisfy the operating requirements imposed by the environmental conditions, a panel indicator lamp shall be provided on the TMC equipment cabinet to indicate the application of heater power.

3.8.4 Local control and transfer group.

(Not required by Contract AF 19(628)-3263)

3.8.5 Remote control and switching group.

(Not required by Contract AF 19(628)-3263)

3.8.6 Test equipment group. - The AN/TRN-( ) shall include one test equipment group consisting of the following:

<u>Item No.</u>	<u>Qty.</u>	<u>Description</u>	<u>(Reference)</u>
1	1	Oscilloscope Assembly . . . . .	3.8.6.1
2	1	Power Meter-Pulse Counter-Marker Generator Assembly. . . . .	3.8.6.2
3	1	Spectrum Analyzer-Test Generator Assembly. . . . .	3.8.6.3

The test equipment furnished by the contractor shall be complete and in accordance with this characteristic. Independent operation (without damage) of any of the test equipment outside the cabinet shall be possible for extended periods. The built-in and integrated test equipment described herein is required for use in connection with test, adjustment, calibration and maintenance of the electronic equipment covered by other sections of this characteristic. The built-in and integrated test equipment shall be capable to test at least the following TACAN beacon system parameters:

- a. Receiver IF Bandpass
- b. Adjacent Channel Rejection \*
- c. Receiver Blanking
- d. Receiver Decoder Rejection \*
- e. Receiver Output Count (Squitter) \*
- f. Receiver Sensitivity \*
- g. North Burst Count \*
- h. North Burst Viewing \*
- i. 15 cycle Azimuth \*
- j. Auxiliary Burst Count \*
- k. Auxiliary Burst Viewing \*
- l. 135 cycle Azimuth \*
- m. Identity Spacing (740  $\mu$ sec) \*
- n. Identity Equalizer (100  $\mu$ sec) \*

- o. Identity Timing (37.5  $\mu$ sec)
- p. Total Pulse Output Count \*
- q. Pulse Droop (North and Auxiliary Bursts) \*
- r. Output Pulse Shape \*
- s. Output Pulse Width \*
- t. Output Pulse Spacing \*
- u. Transmitter RF Spectrum \*
- v. RF Peak Output Power Incident \*
- w. RF Peak Output Power Reflected \*
- x. VSWR (computed from Items v. and w.) \*
- y. Average RF Output Power \*
- z. Transponder Reply Delay \*
- aa. Antenna Speed \*
- bb. Crystal Oscillator Frequency
- cc. Transponder Antenna Radiated Pattern \*

\* The above TACAN beacon system parameter tests shall be accomplished via direct-wired system interconnection and switching. No external test cable patching shall be allowed in the performance of these tests.

3.8.6.1 Oscilloscope assembly. - The oscilloscope assembly shall consist of the following:

<u>Item No.</u>	<u>Qty.</u>	<u>Description</u>	<u>(Reference)</u>
1	1	Basic Oscilloscope Unit. . .	3.8.6.1.1
2	1	Dual Trace Plug-in Unit. . .	3.8.6.1.2
3	1	Time Base Plug-in Unit . . .	3.8.6.1.3
4	1	Set of Probes and Patch Cables	3.8.6.1.4

The oscilloscope shall integrate physically and electrically with other equipment in the AN/TRN-( ) TACAN ground system. The contractor shall ensure that any input or output connections necessary for the integration of the oscilloscope into the test equipment package are compatible with the other connections used in the system.



Specific oscilloscope performance requirements are as specified in the following paragraphs.

3.8.6.1.1 Basic oscilloscope requirements. - The basic oscilloscope shall consist of the following:

<u>Item No.</u>	<u>Qty.</u>	<u>Description</u>	<u>(Reference)</u>
1	1	Vertical Amplifier(with delay line).	3.8.6.1.1.1
2	1	Horizontal Amplifier. . . . .	3.8.6.1.1.2
3	1	Cathode Ray Tube (CRT). . . . .	3.8.6.1.1.3
4	1	Calibrator. . . . .	3.8.6.1.1.4
5	1	High Voltage Power Supply . . . . .	3.8.6.1.1.5
6	1	Low Voltage Power Supply. . . . .	3.8.6.1.1.5
7	1	Z Axis Amplifier. . . . .	3.8.6.1.1.6

3.8.6.1.1.1 Vertical amplifier (main chassis vertical amplifier only). - The oscilloscope main chassis vertical amplifier shall receive its input from the dual-trace plug-in unit (Paragraph 3.8.6.1.2). This completely solid-state push-pull amplifier shall be DC coupled and drive the upper and lower CRT deflection plates. The requirements of the vertical amplifier follow.

3.8.6.1.1.1.1 Sensitivity. - 300 mv/cm  $\pm$  1% through 186  $\Omega$  push-pull (0°C to +40°C).

3.8.6.1.1.1.2 Rise time. - 5.5 nanoseconds  $\pm$  7% (0°C to +40°C).

3.8.6.1.1.1.3 Bandwidth. - DC to 64 Mc at 3 db point  $\pm$  7% (0°C to +40°C).

3.8.6.1.1.1.4 Trace finder. - Provided to permit location of the beam when it is not visible on the face of the CRT. The trace finder shall compress display within graticule area, regardless of vertical and/or horizontal control settings. (Front panel mounted, push button preferred.)

3.8.6.1.1.2 Horizontal amplifier (main chassis horizontal amplifier only). - The horizontal amplifier shall consist of two DC coupled solid-state amplifiers. One

amplifier shall drive the CRT right hand deflection plate; the second shall drive the CRT left hand deflection plate. The requirements of the horizontal amplifier follow.

3.8.6.1.1.2.1 Sensitivity. - 347  $\mu\text{V}/\text{cm}$  per side,  $\pm 1\%$  push-pull ( $-30^\circ\text{C}$  to  $+65^\circ\text{C}$ ).

3.8.6.1.1.2.2 Maximum calibrated deflection rate. - 10 nanoseconds/cm ( $-30^\circ\text{C}$  to  $+65^\circ\text{C}$ ).

3.8.6.1.1.2.3 Bandwidth. - DC to 3 Mc, or higher, at 3 db point.

3.8.6.1.1.2.4 Trace finder. - Provided to permit location of the beam when it is not visible on the face of the CRT. The trace finder shall compress display within the graticule area, regardless of vertical and/or horizontal control settings. (Front panel mounted, push button preferred.)

3.8.6.1.1.2.5 Horizontal positioning controls. - Horizontal positioning controls shall provide horizontal positioning of any signal, within the range of this characteristic, over the screen diameter of the CRT. The horizontal positioning controls shall further meet the requirement of Paragraph 3.8.7.1.3.6 (sweep magnifier). The two horizontal controls shall consist of a horizontal control with approximately three times the range of the vernier horizontal control.

3.8.6.1.1.3 Cathode ray tube (CRT). - The CRT used in the oscilloscope shall be a top quality, rectangular tube, with parallel-ground glass face plates. Useable CRT area shall be 6 cm high by 10 cm wide. The CRT shall further meet the following requirements.

3.8.6.1.1.3.1 Phosphor. - Type P-31 or equivalent.

3.8.6.1.1.3.2 Accelerating potential. - 14 Kv recommended.

3.8.6.1.1.3.3 Graticule markings. - Internally marked in six vertical and 10 horizontal one cm spaces. Two millimeter divisions marked on the vertical and horizontal lines; no parallax.

3.8.6.1.1.3.4 Graticule illumination. - Variable edge lighting; shall produce white (no filters) or red (with filters) graticule markings.

3.8.6.1.1.3.5 Filter. - A high-contrast light and RFI mesh filter shall be provided. The filter shall snap into the light shield and be removable for trace photography.

3.8.6.1.1.3.6 Bezel. - A rectangular (space saver) bezel shall be provided and shall be removable for trace photography.

3.8.6.1.1.3.7 Unblanking. - Bias type, DC coupled from time base plug-in unit (3.8.6.1.3).

3.8.6.1.1.3.8 CRT cathode, Z axis modulation. - Coupling shall be RC (no amplifiers). Input time constant shall be approximately 330  $\mu$ sec. A  $\pm 3$  volt, fast-rise pulse shall produce a visible change in display brightness.

3.8.6.1.1.3.9 Dual trace "chop mode" blanking. - When operating with the dual trace plug-in unit in "chopped mode", the CRT shall be effectively blanked during switching between upper and lower channel inputs or vice versa.

3.8.6.1.1.3.10 Trace rotation control. - A front panel screwdriver adjustment shall permit accurate alignment of the trace with the CRT graticule lines.

3.8.6.1.1.3.11 Intensity. - Intensity shall be such that a two  $\mu$ sec pulse with a rise time of .1  $\mu$ sec or less shall be visible in a fully lighted room. The intensity control circuitry shall permit adjustment of the intensity from completely OFF to full ON.

3.8.6.1.1.3.12 Spot size. - The spot diameter shall not exceed .022 inch when properly focused over the working area of the CRT face.

3.8.6.1.1.3.13 Vertical signal delay lines. - A delay line shall be provided to delay vertical signals for approximately 140 nanoseconds. The delay line shall be

phase and amplitude compensated such that the signal is not distorted and shall require no tuning. This signal delay permits observation of the leading edge of the waveform that triggers the sweep.

3.8.6.1.1.4 Calibrator (voltage). - A voltage calibrator is required. A 100 VDC and an OFF position shall be provided. The calibrator shall further meet the following requirements.

3.8.6.1.1.4.1 Output. - 18 square wave voltages from 0.2 millivolts to 100 volts in a 1-2-5 sequence. Output impedance shall be 50 ohms from 0.2 millivolts to 2.0 volts. Square wave rise and fall time shall be approximately two  $\mu$ secs.

3.8.6.1.1.4.2 Amplitude accuracy. -  $\pm 1\%$  at 0.1 and 100 volts ( $0^{\circ}\text{C}$  to  $+40^{\circ}\text{C}$ ),  $\pm 1.5\%$  ( $-30^{\circ}\text{C}$  to  $+65^{\circ}\text{C}$ ). All other positions of the calibrator switch ( $0^{\circ}\text{C}$  to  $+40^{\circ}\text{C}$ )  $\pm 2\%$ , ( $-30^{\circ}\text{C}$  to  $+65^{\circ}\text{C}$ )  $\pm 3\%$ .

3.8.6.1.1.4.3 Frequency. - Approximately 1 Kc from  $-30^{\circ}\text{C}$  to  $+65^{\circ}\text{C}$ .

3.8.6.1.1.4.4 Current calibrator. - A front panel mounted current probe calibrator shall be provided. The calibration current shall be 5 Ma square wave peak-to-peak  $\pm 1.5\%$ .

3.8.6.1.1.5 Low and high voltage power supplies. - Electronically regulated low and high voltage power supplies shall be provided. The power supplies shall provide stable, low drift operation. All power supplies shall be protected against accidental short circuit.

3.8.6.1.1.6 Z axis amplifier. - A DC coupled amplifier for CRT grid Z axis modulation shall be provided. The requirements of the Z axis amplifier are as follows:

3.8.6.1.1.6.1 Gain. - Amplifier gain shall be at least 1.5 with an input resistance of approximately 22 K ohms.

3.8.6.1.1.6.2 Bandwidth. - Amplifier bandwidth shall be at least DC to 10 Mc at the 3 db point.

3.8.6.1.1.6.3 Sensitivity. - Sensitivity shall be such that  $\pm 2$  volts peak will produce a visible change in CRT brightness.

3.8.6.1.2 Dual-trace plug-in unit. - The dual-trace plug-in unit requirements specified hereunder include, where applicable, the characteristics and/or effect of the chassis mounted vertical amplifier of Paragraph 3.8.6.1.1 et al. Specific performance requirements of the dual-trace plug-in unit in conjunction with the main vertical amplifier are as follows:

3.8.6.1.2.1 Frequency response. - DC to 50 Mc minimum AC coupled; 2 cps to 50 Mc minimum ( $0^{\circ}\text{C}$  to  $+40^{\circ}\text{C}$ ), DC to 40 Mc at -3 db points ( $-30^{\circ}\text{C}$  to  $+65^{\circ}\text{C}$ ) useable at 75 Mc.

3.8.6.1.2.2 Rise time. - Rise time shall be seven nanoseconds or less ( $0^{\circ}\text{C}$  to  $+40^{\circ}\text{C}$ ).

3.8.6.1.2.3 Stability and accuracy. - AC gain stability and accuracy shall be equal to or greater than  $\pm 1.5\%$  ( $0^{\circ}\text{C}$  to  $+40^{\circ}\text{C}$ )  $\pm 3\%$  ( $-30^{\circ}\text{C}$  to  $+65^{\circ}\text{C}$ ). Lower channel amplifier stability and accuracy shall not be less than  $\pm 1\%$  ( $0^{\circ}\text{C}$  to  $+40^{\circ}\text{C}$ )  $\pm 2\%$  ( $-30^{\circ}\text{C}$  to  $+65^{\circ}\text{C}$ ).

3.8.6.1.2.4 Operating modes. - Five operating modes shall provide for: Channel one only, normal or inverted; Channel two only, normal or inverted; Alternate between channels; Chopped between channels at 1 Mc rate  $\pm 10\%$ ; Added algebraically.

3.8.6.1.2.5 Bandwidth. - 50 Mc minimum ( $0^{\circ}\text{C}$  to  $+40^{\circ}\text{C}$ ), 40 Mc ( $-30^{\circ}\text{C}$  to  $+65^{\circ}\text{C}$ ).

3.8.6.1.2.6 Deflection factors and sensitivity. - Each channel shall have 11 calibrated steps from 10 mv/cm to 20 v/cm in a 1-2-5 sequence. A concentric variable control with at least 2.5:1 uncalibrated range shall extend the maximum deflection factor to 50 v/cm. A lamp labeled UNCAL shall light when the VARIABLE control is turned away from its CALIB position.

3.8.6.1.2.7 Input impedance. - Input impedance shall be one megohm paralleled by 20  $\mu\text{mfd}$ .

3.8.6.1.2.8 Calibration accuracy. - Accuracy shall be adjustable to zero % at 10 mv/cm via a front panel GAIN control.

3.8.6.1.2.9 Attenuation accuracy. - Accuracy shall be  $\pm 2\%$  from  $-30^{\circ}\text{C}$  to  $+65^{\circ}\text{C}$ .

3.8.6.1.2.10 Amplifier balance. - Front panel adjustments shall be provided for accessible balancing of both input amplifiers.

3.8.6.1.2.11 Input voltage. - Application of 600 V combined DC or AC peak shall not damage the equipment.

3.8.6.1.2.12 Inverted polarity. - Both channels shall be provided with signal inverter switches.

3.8.6.1.2.13 Isolation. - At least 80 db from DC to 25 Mc, except when the MODE switch (Paragraph 3.8.6.1.2.4) is in ADDED ALGEBRAICALLY position.

3.8.6.1.2.14 Input selector. - Individual input selector controls shall be provided for selection of either AC or DC vertical signal coupling when a signal is applied via the front panel BNC input jacks of channel one or two.

3.8.6.1.2.15 Vertical positioning. - A vertical position control for each channel shall provide for the vertical positioning of any signal, within the range of this characteristic, over three screen diameters of the CRT.

3.8.6.1.2.16 Plug-in unit connections. - All power and internal signal paths shall be automatically connected to the dual channel amplifier when the dual channel amplifier is inserted into the main oscilloscope chassis.

3.8.6.1.2.17 Common mode rejection. - In the added (algebraically) mode, the common mode rejection shall be at least 20:1 up to 25 Mc for common mode signals up to 10cm.



3.8.6.1.2.18 Display linearity. - A 1 cm centered signal shall not change amplitude over  $\pm 1\%$  when offset to the top or the bottom of the graticule. (Offset voltage externally applied and position control centered.)

3.8.6.1.2.19 Internal triggering (signal sync). - A front panel switch shall switch internal vertical signal trigger information to the time base sub-unit for sweep triggering purposes. A front panel trigger switch shall also be provided to allow for lower channel triggering only. Triggering from the lower channel only shall provide correct time relationship between channels when operating in alternate or chopped modes. Signals to the time base sub-unit shall allow reliable internal triggering to at least 50 Mc/s.

3.8.6.1.2.20 Lower channel amplifier output. - The lower channel output shall be available at the front panel for external triggering or driving of other equipment. This 10 X output, when fed into the upper channel input, shall provide a calibrated 1 mv/cm sensitivity at a DC to 20 Mc/s bandwidth. The lower channel output impedance shall be 100 ohms. It shall be possible to use the lower channel amplifier as a preamplifier for the upper channel amplifier. It shall be possible to use the lower vertical channel amplifier as a horizontal amplifier when the horizontal display switch (part of time base plug-in unit) is set to the appropriate position. This capability shall provide a wide variety of horizontal gain settings ( a wide range of horizontal deflections shall thus be obtained). This feature shall permit the oscilloscope system to plot one function against another (e.g., Lissajous figures).

3.8.6.1.2.21 DC trace displacement. - DC drift shall not exceed 1 cm/20°C (0°C to 40°C). DC drift shall be allowed to exceed 1 cm/20°C from -30°C to +65°C, excluding the temperature band of 0°C to +40°C.

3.8.6.1.3 Time base plug-in unit. - The time base plug-in unit shall contain two separate time base generators ("A" and "B") which shall provide for calibrated



sweep delay. Time base "A" shall be the normal sweep and this sweep shall also be used to delay the start of the second sweep (time base "B").

3.8.6.1.3.1 Time base sweep speed ("A" and "B"). - Each time base sweep shall have 24 calibrated steps and provide sweep rates from 0.1  $\mu\text{sec}/\text{cm}$  to 5  $\text{sec}/\text{cm}$  in a 1-2-5 sequence. Uncalibrated (2.5:1 variable "A" and "B") controls shall provide continuously variable sweep rates between 0.1  $\mu\text{sec}/\text{cm}$  and approximately 12  $\text{sec}/\text{cm}$ . A front panel lamp shall indicate uncalibrated sweep rate.

3.8.6.1.3.2 Delaying sweep. - "A" sweep shall be the delaying sweep and when used as a delay generator, shall provide 21 overlapping, calibrated delay-time ranges from 1  $\mu\text{sec}$  to 50  $\text{sec}$ . (The 0.1  $\mu\text{sec}$ , 0.2  $\mu\text{sec}$ , and 0.5  $\mu\text{sec}$  "A" sweeps are normally not used for delay generator.)

3.8.6.1.3.2.1 Delay time multiplier. - The delay time multiplier shall be a 10 turn, calibrated precision potentiometer that accurately multiplies the delay time indicated by the delay time switch to a maximum of 10 times.

3.8.6.1.3.3 Accuracy "A" time base sweep. - Accuracy of the displayed sweep, 0.1  $\mu\text{sec}$  to 5  $\text{sec}$ , shall be +4 to -6% or less from  $-30^{\circ}\text{C}$  to  $+65^{\circ}\text{C}$  and shall be  $\pm 3\%$  or less from  $0^{\circ}\text{C}$  to  $+40^{\circ}\text{C}$ . Accuracy of the delaying sweep, 1.0  $\mu\text{sec}$  to 5  $\text{sec}$ , shall be +3 to -6% or less from  $-30^{\circ}\text{C}$  to  $+65^{\circ}\text{C}$  and shall be  $\pm 3\%$  or less from  $0^{\circ}\text{C}$  to  $+40^{\circ}\text{C}$ .

3.8.6.1.3.4 Triggering. - "A" and "B" time base trigger requirements for internal triggering shall not be greater than 2 cm deflection to 50 Kc and 1 cm deflection at 50 Mc. "A" and "B" time base trigger requirements for external triggering shall not be greater than 125 mv to 50 Kc and 250 mv at 50 Mc.

3.8.6.1.3.4.1 "A" trigger mode switch. - A front panel, concentric 5 position switch shall select the following trigger modes of operation: Free-running, automatic, AC, AC low frequency reject and DC. Automatic triggering shall provide a bright reference trace (regardless of sweep speed) when no input signal is applied,

or when the input signal repetition rate is less than 20 cps. Above 20 cps, time base "A" shall be triggered at the repetition rate of the incoming trigger signal to achieve jitter-free displays to beyond 50 Mc. AC low frequency reject shall prevent low-frequency components, such as 15, 60, or 135 cps from interfering with stable operation (-3 db at 17 Kc).

3.8.6.1.3.4.2 "A" trigger source switch. - A front panel, eight position switch shall select the following trigger sources for operation: + or - line, + or - internal, + or - external, + or - external  $\div 10$ .

3.8.6.1.3.4.3 External trigger "A" input. - A front panel BNC jack shall be provided. External triggering shall be accomplished via this jack by switching the "A" trigger source switch (Paragraph 3.8.6.1.3.4.2) to external + or - position, setting the trigger mode switch (Paragraph 3.8.6.1.3.4.1) to the desired position, and adjusting the trigger level control (Paragraph 3.8.6.1.3.4.4).

3.8.6.1.3.4.4 Trigger level control. - A front panel potentiometer shall adjust to allow sweep triggering at any selected point on either the rising or falling portion of the waveform up to  $\pm 5$  v ( $\pm 50$  v in the external  $\div 10$  position of the trigger source switch, Paragraph 3.8.6.1.3.4.2).

3.8.6.1.3.4.5 High frequency stability and single sweep time base "A" switch/potentiometer. - A front panel switch/potentiometer shall be provided. The high frequency stability control shall be used, if necessary, with triggering signals above 5 or 10 Mc to obtain best display stability (minimum jitter). This control shall have no effect at lower triggering signal frequencies. The switch portion of the switch/potentiometer shall be used as a single sweep control to facilitate photographic recording at waveforms displayed in time base "A". A reset (front panel push button) shall arm the sweep to fire on the next received trigger. After firing once, the sweep shall be locked out until rearmed by pressing the reset button. A front panel light shall be provided to indicate when the sweep is armed to fire on the next received trigger.

3.8.6.1.3.5 Gate and sawtooth outputs. - Four front panel mounted, miniature type, connectors shall be provided on the time base plug-in unit front panel. Two shall provide 10 v, positive-going, "A" and "B" time base sweep outputs, and two shall provide 15 v, positive-going, "A" and "B" time base gate outputs.

3.8.6.1.3.6 Sweep magnifier. - A concentric, two position switch shall expand the 1 cm portion of the normal display at the horizontal center of the graticule to fill 10 cm. It shall then be possible to observe any 1 cm portion of the original unmagnified display, in the magnified form, by using the horizontal position control (Paragraph 3.8.6.1.1.2.5) to position that portion on the CRT. The X 10 magnifier shall also be used to extend the calibrated sweep time to 10 nanosecond/cm. A front panel lamp shall light when the X 10 magnifier is in the ON position.

3.8.6.1.3.7 "B" time base sweep. - Horizontal deflection sources for sweep generator "B" shall be: delayed, delayed and triggered, and external sources.

3.8.6.1.3.7.1 Sweep delay. - "B" time base shall be utilized as the delayed sweep. When sweep delay is used, "B" sweep start shall be delayed by time base "A". Actual oscilloscope deflection shall be provided by time base "B". The beginning of "B" sweep shall be delayed from the beginning of "A" sweep by a time equal to the product of the "A" delay time switch (Paragraph 3.8.6.1.3.2) and the delay time multiplier dial setting (Paragraph 3.8.6.1.3.2.1). Sweep delay accuracy, 0.1  $\mu$ sec/cm to 5 sec/cm, shall be + 2 to -5% or less from -30°C to +65°C. Accuracy shall be  $\pm$ 3% or less from 0°C to +40°C.

3.8.6.1.3.7.2 "B" trigger input. - A front panel BNC jack shall be provided for "B" time base triggering. This input shall also function as the horizontal amplifier input jack when so selected by the horizontal display switch (Paragraph 3.8.6.1.3.8).

3.8.6.1.3.7.3 "B" trigger level. - A concentric, front panel potentiometer shall select the amplitude point on the triggering signal (+ or -, rising or falling) where sweep triggering will occur. The control voltage range (external triggering) shall be approximately  $\pm 13$  volts,  $\pm 10$  volts minimum.

3.8.6.1.3.7.4 "B" trigger source switch. - A front panel, eight-position switch shall select the following trigger sources for operation: Internal trigger + or - AC, + or - DC, and external trigger + or - AC, + or - DC.

3.8.6.1.3.8 Horizontal display. - A front panel, six-position switch shall select any one of the following: (1) "B" sweep delayed by "A" sweep. The horizontal deflection shall be provided by time base "B" (Paragraph 3.8.6.1.3.7.1). (2) "A" sweep intensified by "B" sweep. The horizontal deflection shall be provided by time base "B". The intensified zone shall be the "B" sweep and shall provide a visual check on relative duration and time position of "B" sweep. (3) The horizontal deflection shall be provided by time base "A". Delayed sweep shall be inoperative. (4) "A" sweep intensified by "B" sweep. (5) "B" sweep delayed by "A" sweep shall be the same as stated above except that the "B" (delayed sweep) triggering controls and switches shall be utilized. Instead of "B" sweep beginning at the end of the selected delay period, time base "B" shall become triggerable. "B" sweep must be triggered after the delay period, but before the end of "A" sweep. (6) External input. External signals applied to the "B" trigger input connector (Paragraph 3.8.6.1.3.7.2) shall provide the horizontal deflection.

3.8.6.1.4 Probes and patch cables. - The following items shall be provided:

3.8.6.1.4.1 RF probes. - Two high impedance probes shall be provided, each consisting of 72 inches of non-ringing, low noise cable, terminated at one end with a male BNC connector, and terminated at the other end with a probe, and shall present an impedance of 10 megohms  $\pm 10\%$  shunted by not more than 25  $\mu\text{fd}$  when used with the oscilloscope. These RF probes shall be Tektronix type P6006, or

equal, and shall be subject to the approval of the USAF. Probes will not be damaged by the application of a signal of 600 volts maximum (color code: one red and one black).

3.8.6.1.4.2 Patch cables. - Two patch cables, each consisting of 72 inches of RG-233/U or equivalent cable, terminated at both ends with male BNC connectors, shall be provided.

3.8.6.2 Power meter - pulse counter - marker generator assembly. - The power meter-pulse counter - marker generator (PM-PC-MG) shall provide direct reading indications of the repetition rate of all pulse sources in the AN/TRN-( ) equipment, circuitry for measuring the peak RF output power and VSWR, circuitry for generating markers to be used for test purposes and circuitry for checking the AN/TRN-( ) crystal oscillators. The PM-PC-MG shall consist of the following:

<u>Item No.</u>	<u>Qty.</u>	<u>Description</u>	<u>(Reference)</u>
1	1	Power Meter Unit	3.8.6.2.1
2	1	Pulse Counter Unit	3.8.6.2.2
3	1	Marker Generator Unit	3.8.6.2.3
4	1	Frequency Meter Unit	3.8.6.2.4

The PM-PC-MG shall integrate physically and electrically with other equipment in the AN/TRN-( ) TACAN ground system. The contractor shall ensure that any input or output connections necessary for the integration of the PM-PC-MG into the test equipment package are compatible with the other connections used in the system. The equipment shall include a color-coded front panel for simple operation, counter input jack, test jack for checking counter-input level indicator, self-check features, calibration check against WWV, crystal and oven indicator lights and start/reset button. The function switches shall be integrated with other test assemblies of this characteristic. Specific PM-PC-MG performance requirements are as specified in the following paragraphs.

3.8.6.2.1 Power meter unit requirements. - The peak power meter shall be a peak riding RF power measuring device capable of measuring peak power instantaneously. Further power meter requirements follow.

3.8.6.2.1.1 Accuracy. -  $\pm 5\%$  over a minimum range of 11.5 db from 960 to 12.3 Mc.

3.8.6.2.1.2 Meter calibration. - The meter shall be calibrated in relative power with a full-scale reading of 2, and shall include a red-lined inciation at 1. Graduations in steps of 0.2 shall be provided.

3.8.6.2.1.2.1 Meter controls. - Meter zero controls are provided on the front panel for setting the meter to zero prior to RF power measurements.

3.8.6.2.1.3 Frequency response. - The power meter output indication shall be within  $\pm 2\%$  with change in pulse count over the range 20 to 10,000 pps.

3.8.6.2.1.4 Calibration. - Provision shall be made for checking the peak RF power measuring device without any additional test equipment except specified herein.

3.8.6.2.1.5 Linear detector. - A detector with a linearity of  $\pm 5\%$  shall be provided to permit observation of the transponder output, irrespective of what test is being performed by the test equipment called out herein. The detector shall be permanently wired but accessible, insofar as its input and output are concerned, from the front panel of the PM-PC-MG.

3.8.6.2.1.6 VSWR. - The power meter shall permit measurement of incident and reflected power from which VSWR can be calculated.

3.8.6.2.2 Pulse counter unit requirements. - The pulse counter shall provide for direct readout of the number of pulses counted up to a total of 10,000,000 at pulse spacings of five  $\mu$ secs or more, as required for the following:

- a. North burst count;
- b. Auxiliary burst count;
- c. Reference burst count (total);



- d. Squitter count;
- e. Total pulse count;
- f. Receiver reply count;
- g. Monitor reply rate/reply count calibration;
- h. Identity tone and burst pulse count; and
- i. Antenna rotation rate.

Further pulse counter requirements follow:

3.8.6.2.2.1 Frequency and time indicators. - The frequency or time interval shall be displayed on five in-line "nixie" long-life readout tubes, accessible from the PM-PC-MG front panel.

3.8.6.2.2.2 Decimal indicator. - Decimal point indicator devices shall be provided between the appropriate nixie tubes for indicating decimal readings of frequency or time. An automatic decimal point which shifts with a time interval switch shall indicate the one Kc point during frequency measurements and the milli-second point during time interval measurements.

3.8.6.2.2.3 Display time. - The answer display time shall be variable from approximately 0.5 to 30 seconds. After the measurement period and the display period of a single measurement have elapsed, the display and signal input circuitry shall reset automatically and a new measurement period shall start. Means shall be provided to hold the display indefinitely if desired.

3.8.6.2.2.4 Frequency standard. - The equipment shall operate from either an internal frequency standard source or an external AC frequency standard of one Mc, one VRMS, at an impedance of 50 ohms. The frequency source shall be selected by a front panel control.

3.8.6.2.2.5 Internal frequency standard source. - The internal frequency standard source shall be a quartz crystal-controlled oscillator operating at a frequency of one Mc, from which gate times, standard counted frequencies, and standard frequency outputs may be derived.



3.8.6.2.2.5.1 Stability. - The stability of the crystal controlled oscillator measured over one-second intervals shall be within one part in  $10^5$  over a two-week period after the warm-up time.

Note: The time required for warm-up shall be provided.

3.8.6.2.2.5.2 Accuracy. - The accuracy of the equipment shall be set within one part in  $10^5$  of one Mc at the factory. During frequency measurements the accuracy shall be  $\pm 1$  count  $\pm 1/10^5$ .

3.8.6.2.2.6 Gate times. - Provisions shall be made on the front panel for selection of either the 0.001, 0.01, 0.1, 1.0 or 10 second counting intervals and locating the decimal point for indicating the frequency in kilocycles or time interval in milliseconds. Each of these intervals shall be made available from the internal standard by means of frequency divider circuits.

3.8.6.2.2.7 Sensitivity. - Input voltages of 0.5 to 200 volts peak-to-peak with characteristics specified in 3.8.6.2.2.8 shall permit proper operation of the equipment.

3.8.6.2.2.8 Input signals. - All system pulses having characteristics specified in Paragraph 3.8.1.1.1.10, et al, pulse widths of 0.5  $\mu$ sec or more, and of either polarity, shall be countable. A switch shall be provided for polarity selection. In addition, either the positive or negative portion of sine wave or square wave voltages shall be counted.

3.8.6.2.2.9 Input level indicator. - A meter type level indicator shall be provided with a zoned marking (in green) to indicate minimum and maximum input levels which will provide satisfactory performance of the pulse counter. A coarse and fine counter control shall be provided. During RF measurements, an attenuator shall be provided for adjusting the level of the input signal.

3.8.6.2.2.10 Input impedance. - The input impedance for external inputs shall be not less than one megohm shunted by not more than 45  $\mu\text{f}$ .

3.8.6.2.2.11 Standard frequency. - Standard frequency signals derived from the internal frequency standard shall be made available for test purposes as required by the USAF.

3.8.6.2.3 Marker generator unit requirements. - An internal marker generator shall be provided. The marker generator shall meet the following requirements.

3.8.6.2.3.1 Marker range. - The marker generator shall provide six precise marker pulses at intervals of 0.5, 1.0, 10, 1,000, and 10,000  $\mu\text{secs}$ , suitable for sharp and clear intensity modulation of the oscilloscope (Paragraph 3.8.6.1), and shall not contain appreciable overshoot or ringing. When operated into the oscilloscope Z-axis amplifier (3.8.6.1.1.6) through the cable harness, the marker generator rise and fall times shall be less than 0.05  $\mu\text{sec}$  for the 0.5 and 1.0  $\mu\text{sec}$  markers; 0.1  $\mu\text{sec}$  for the 10  $\mu\text{sec}$  marker; 0.2  $\mu\text{sec}$  for the 100  $\mu\text{sec}$  marker; 0.3  $\mu\text{sec}$  for the 1,000  $\mu\text{sec}$  marker; and 0.4 for the 10,000  $\mu\text{sec}$  marker. The nominal pulse width shall be stable to  $\pm 20\%$ . Recommended nominal marker width is 0.1  $\mu\text{sec}$  for the 0.5 and 1.0  $\mu\text{sec}$  intervals, 0.2  $\mu\text{sec}$  for the 10  $\mu\text{sec}$  interval, and 2.0, 20, and 200  $\mu\text{secs}$  for the 100, 1,000 and 10,000  $\mu\text{sec}$  intervals, respectively.

3.8.6.2.3.2 Marker accuracy. - The marker pulse facility shall be capable of being directly calibrated against the internal frequency standard specified in Paragraph 3.8.6.2.2.5 without the use of external connections. The crystal standard shall be accurate to within  $\pm 0.001\%$ .

3.8.6.2.3.3 Marker output. - The output of the marker generator shall be interconnected to the sweep circuit (Z-axis amplifier (Paragraph 3.8.6.1.1.6) of the oscilloscope. The marker pulses shall be automatically synchronized with the associated oscilloscope sweep and positioned upon the waveshape being viewed. The

jitter between markers and sweep shall not exceed 0.05% at the displayed sweep. Each tenth marker shall be automatically brightened.

3.8.6.2.3.4 Marker delay. - Provisions shall be made on the front panel of the PM-PC-MG for delaying of markers with relation to oscilloscope sweep-time up to approximately 11,000  $\mu$ secs.

3.8.6.2.3.5 Marker selector. - A marker selector switch shall be located on the front panel of the PM-PC-MG to permit selection of markers of any one of the spacing specified in Paragraph 3.8.6.2.3.1.

3.8.6.2.3.6 Marker intensity control. - A front panel control shall be provided for increasing or decreasing the intensity of the markers.

3.8.6.2.3.7 Marker self-check. - Means shall be available to self-check the marker's accuracy with the built-in digital counter and against WWV or other such external standards as may be available.

3.8.6.2.3.8 Marker output jack. - A marker output jack for external calibration and vertical presentation shall be provided on the PM-PC-MG front panel.

3.8.6.2.4 Frequency meter requirements. - A digital frequency meter shall be provided for checking of all AN/TRN-( ) crystal oscillators. The frequency meter shall meet the following requirements.

3.8.6.2.4.1 Input range. - The input range of the frequency meter shall encompass all crystal frequencies which are utilized within the 126 channel operating band of the AN/TRN-( ).

3.8.6.2.4.2 Accuracy. - Accuracy shall be  $\pm$  0.001% or greater.

3.8.6.2.4.3 Input jack. - A frequency meter input BNC jack shall be provided on the PM-PC-MG front panel. The input impedance of this jack shall be sufficiently

high to eliminate any pulling of the crystal frequency under test when the frequency meter is properly connected.

3.8.6.2.4.4 Readout. - Frequency readout shall be on the five in-line "nixie" readout tubes of Paragraph 3.8.6.2.2.1.

3.8.6.3 Spectrum analyzer - test generator assembly. - The spectrum analyzer - test generator (SA/TG) shall consist of the following:

<u>Item No.</u>	<u>Qty.</u>	<u>Description</u>	<u>(Reference)</u>
1	1	Spectrum Analyzer Unit	3.8.6.3.1
2	1	Test Generator Unit	3.8.6.3.2

The SA/TG shall integrate physically and electrically with other equipment in the AN/TRN-( ) TACAN ground system. The contractor shall ensure that any input or output connections necessary for the integration of the SA/TG into the test equipment package are compatible with the other connections used in the system. The SA/TG shall provide capabilities for measuring average power, including that of the transponder beacon. All necessary controls for optimum operation at the SA/TG shall be provided. Specific SA/TG performance requirements are as specified in the following paragraphs.

3.8.6.3.1 Spectrum analyzer requirements. - The spectrum analyzer (SA) shall consist of a double superheterodyne receiver, with crystal controlled local oscillators, and a well defined bandpass response with high selectivity. Suitable detectors shall be provided to make it possible to measure the transmitted energy in each of six bands in the neighborhood of the transponder transmitter frequency, as well as the energy on channel. Further requirements of the SA follow.

3.8.6.3.1.1 Spectrum. - The SA shall be capable of measuring up to 70 db spectrums at a maximum signal of +14 dbw peak and a minimum signal of +5 dbw peak at the standard TACAN transponder duty cycle specified in MIL-STD-291A. Measurement accuracy shall be  $\pm 3$  db of absolute spectrum.

3.8.6.3.1.2 Protection. - The SA shall not be damaged, nor shall its electrical characteristics be changed perceptibly when the transponder output signal is continuously present at its input connector at a peak pulse power of 30 watts and an average power of one watt.

3.8.6.3.1.3 Crystal control. - A crystal controlled first local oscillator shall be used to provide crystal controlled operation at any single signal frequency in the range of 960 to 1215 Mc. Not more than 30 minutes shall be required to insert a crystal and to tune all stages of the SA.

3.8.6.3.1.3.1 Frequency stability. - The first local oscillator frequency stability shall be maintained within  $\pm 0.001\%$  of the assigned channel frequency under the service conditions of this characteristic.

3.8.6.3.1.4 Preselector bandwidth. - Input preselector bandwidth shall not be less than 5.0 Mc at the 0.4 db points and the response within these limits shall not drop more than 0.25 db below the maximum response level.

3.8.6.3.1.5 Frequency band selector. - The second local oscillator shall be tunable to any one of seven crystal controlled frequencies by means of a front panel selector switch. Crystal units shall be provided for this application. When the receiver is tuned to the assigned channel frequency of the transponder transmitter, the operation of this switch shall permit measurement of relative transmitted energy in seven narrow bands (Paragraph 3.8.6.3.1.5.2), centered as follows:

- a. On frequency (center frequency);
- b.  $\pm 0.8$  Mc away from center frequency;
- c.  $\pm 1.0$  Mc away from center frequency; and
- d.  $\pm 2.0$  Mc away from center frequency.

3.8.6.3.1.5.1 Frequency stability and accuracy. - The second local oscillator frequencies shall be maintained within 0.002%. The center of the receiver second IF

bandpass shall not deviate by more than  $\pm 20$  Kc under all service conditions, including the drift of local oscillators and all tuned circuits.

3.8.6.3.1.5.2 Bandpass. - The nominal frequency bandpass at the second IF amplifier shall be 500 Kc.

3.8.6.3.1.6 Spurious response. - The response of the receiver to either IF shall be suppressed by at least 65 db. All other spurious responses shall be suppressed by at least 70 db.

3.8.6.3.1.7 Sensitivity. - The sensitivity shall be such that an input signal level of not greater than -50 dbm will produce the required reference "signal set" data on the indicator meter when the attenuator (Paragraph 3.8.6.3.1.8) is set to minimum attenuation.

3.8.6.3.1.8 Attenuator. - A precision direct readout input attenuator with low insertion loss shall be provided on the front panel for control of the input signal level. The attenuator shall be calibrated over a range of not less than 110 db in increments of 1 db. The accuracy of the attenuator shall be  $\pm 1.0$  db of the indicated value over the full range; the input impedance shall be 50 ohms and the voltage standing wave ratio (VSWR) shall not exceed 1.5:1 over the frequency band 959 to 1215 Mc, and over the calibrated attenuation range.

3.8.6.3.1.9 Output indicator. - The final IF amplifier of the SA shall be terminated in a thermistor bridge assembly which shall operate an indicating meter. The readings on the indicating meter shall be a function of the average power output of the receiver with an accuracy of  $\pm 0.25$  db at the "signal set" data. This performance shall be obtained for either CW or pulsed signals. The signal set reference data shall be indicated by a red line or other suitable marking. Means for calibration shall be provided.

3.8.6.3.1.10 External oscillator. - Provision shall be made for an external oscillator facility, whereby when the second local oscillator crystal selector switch



(Paragraph 3.8.6.3.1.5) is indexed to the external oscillator position, it is possible to substitute the CW local oscillator signal (Paragraph 3.8.6.3.1.3) with an external oscillator to permit measurement of energy levels at frequencies other than those provided for by the specified crystals. The required oscillator signal input level shall be one milliwatt into 50 ohms.

3.8.6.3.1.11 Shielding. - The SA shall be sufficiently well shielded so that, with the input plug capped (but not short circuited), the output shall drop at least 80 db from that available with normal connection. This requirement shall be met with the analyzer mounted in its normal position in the test-monitor-control cabinet of the AN/TRN-( ) and for all SA control settings and frequencies.

3.8.6.3.2 Test generator unit requirements. - The test generator unit shall consist of the following:

<u>Item No.</u>	<u>Qty.</u>	<u>Description</u>	<u>(Reference)</u>
1	1	63 Mc CW Signal Generator	3.8.6.3.3
2	1	RF Signal Generator	3.8.6.3.4

3.8.6.3.3 63 Mc CW signal generator requirements. - The purpose of the 63 Mc CW is to provide a 63 Mc CW output signal for alignment and trouble-shooting of the intermediate frequency (IF) stages of the AN/TRN-( ) transponder receiver. Further requirements of the 63 Mc CW signal generator follow.

3.8.6.3.3.1 Output level. - The 63 Mc CW generator shall have an output level variable over a range of 0dbm to -110 dbm with an accuracy of  $\pm 2$  db when the output attenuator is terminated in a 50 ohm load.

3.8.6.3.3.2 Frequency control resolution. - The 63 Mc CW generator shall be tunable  $\pm 3$  Mc from 63.0000 Mc. The frequency control resolution shall be 20 Kc when the counter on the PM-PC-MG is used.



3.8.6.3.3.3 Frequency readout accuracy. - Over the 3 Mc frequency range specified in Paragraph 3.8.6.3.3.2, a frequency readout accuracy of  $\pm 5$  Kc shall be provided.

3.8.6.3.3.4 Amplitude modulation. - Amplitude modulation shall not be greater than 2%.

3.8.6.3.3.5 Frequency modulation. - Frequency modulation shall be less than 1 Kc.

3.8.6.3.3.6 Spurious output. - Spurious output shall be 40 db under the level of the attenuator output.

3.8.6.3.3.7 Sweep feature. - A sweep feature shall be provided, utilizing frequency markers, for accurate oscilloscope presentations.

3.8.6.3.4 RF signal generator requirements. - The purpose of the RF signal generator is to provide CW or pulsed output signals over the frequency range of 1024 to 1151 Mc for troubleshooting of the AN/TRN-( ) transponder.

3.8.6.3.4.1 Crystal control. - A crystal controlled oscillator shall be provided to insure operation within 0.001% of the nominal value of the desired frequency. Tuning procedures shall be as simple as possible and all necessary indicators and controls shall be included.

3.8.6.3.4.2 Output frequencies. - The RF signal generator shall provide RF output signals for interrogation at channel frequencies from 1024 to 1151 Mc.

3.8.6.3.4.3 Frequency select switch. - A frequency select switch shall be provided for the selection of on channel frequencies and frequencies removed  $\pm 200$  Kc and  $\pm 900$  Kc from the selected on channel frequency. The required performance shall be achieved at all five frequencies without retuning of the RF signal generator circuits. The output level shall remain constant, within  $\pm 0.5$  db, for all five frequencies, when the power monitor is reset to "red line".

3.8.6.3.4.4 Output level. - The RF output level shall be continuously variable between the limits of at least 0 dbm and -110 dbm as measured across a 50 ohm resistive load at the front panel of the SA/TG and shall have an accuracy of  $\pm 1$  db.

3.8.6.3.4.5 Calibration. - Means shall be provided for establishing a reference calibration level for CW output power of the RF signal generator. The RF signal generator shall also provide means for setting and checking the RMS value of the CW power at calibration level. If external test equipment is required, the oscilloscope (Paragraph 3.8.6.1) may be used. Adjustment of the output attenuator to any setting within the range 0 dbm to 110 dbm shall not result in a variation of the output reference calibration level of more than  $\pm 0.5$  db. The output attenuator shall not be damaged, nor shall its electrical characteristics be changed perceptibly when, in addition to the RF signal generator output signal at maximum level, the transponder output signal is continuously present at the input connector at a peak pulse power of 30 watts and an average power of one watt.

3.8.6.3.4.6 RF envelope detection. - A detector linear within  $\pm 5\%$  shall be provided to permit examination of the RF signal generator output pulse envelope with the oscilloscope (Paragraph 3.8.6.1).

3.8.6.3.4.7 Output pulse. - The RF signal generator shall provide, from the detector specified in Paragraph 3.8.6.3.4.6, undistorted video pulse pairs, having pulse amplitude, duration, and pulse shape characteristics compatible with the requirements of Paragraph 3.8.1.1.1.10 et al., of this characteristic. The CW output between pulse pairs shall be 100 db below the peak RF output from the attenuator. Front panel controls shall be provided for continuously varying the pulse repetition rate from 4 to 4000 pulse pairs per second with a dial marking accuracy of  $\pm 10\%$  over the range ( $\pm 5\%$  at extremes). Spacing of paired trigger pulses shall be controlled by front panel pulse spacing controls and a chassis mounted 12/36  $\mu$ sec spacing selector switch. The front panel pulse spacing controls shall provide pulse spacing within the pair  $\pm 3$   $\mu$ secs from the nominal 12 or 36  $\mu$ secs.

3.8.6.3.4.8 External trigger. - It shall be possible to trigger the pulse pair generator with an external source of positive or negative triggers at any repetition rate from 4 to 4,000 pulse pairs per second.

3.8.6.3.4.9 Interlock facility. - Facilities shall be provided to ensure that the RF signal generator is not used in a manner which will produce CW jamming of a transponder when the transponder is operating into the antenna.

3.8.7 Shelter group.

(Not required by Contract AF 19(628)-3263)

3.8.8 Antenna elevator group.

(Not required by Contract AF 19(628)-3263)

3.9 Part numbering.- All parts having the same manufacturer's part number shall be functionally and dimensionally interchangeable. The item identification and part number requirements of MIL-D-70327 shall govern the manufacturer's part numbers and changes thereto.

3.10 Color.

3.10.1 Exterior.- The exterior surfaces of the shelter, with the exception of the undercarriage, shall be olive drab green, code 24064, of Federal Standard 595. The antenna and antenna mast shall conform to the same color as that of the exterior surface of the shelter, code 24064.

3.10.2 Undercarriage.- The exterior surfaces of the shelter undercarriage shall be black, code 27038, of Federal Standard 595.

3.10.3 Interior.- The interior surfaces of the shelter, namely the walls and ceiling, shall be light grey. The color shall conform to Class 2 of MIL-E-15090.

3.10.4 Floor.- The interior floor surface of the shelter shall be grey, code 36118, of Federal Standard 595.

3.11 Finish.

3.11.1 Exterior.- All exterior exposed surfaces, materials, and processes of the shelter, antenna mast, and antenna shall conform to MIL-F-14072, except that QQ-N-290 shall be used where applicable.

3.11.2 Interior.- All interior surfaces of the shelter shall be free from burrs and roughness. All surfaces shall be processed to prevent oxidation from occurring.

The finish shall not impair chassis electrical ground.

3.12 Weight.- The total weight of the AN/TRN-( ) shall not exceed 5,500 pounds.

3.13 Operation markings.- Special handling instructions, markings, and warnings shall be in accordance with MIL-STD-129C.

3.14 Identification of product.- All nameplates shall be specially designed as to size and wording for identification in accordance with MIL-STD-130. Foil type nameplates shall not be used. Each ground station equipment shall have one main nameplate which shall be mounted on the front of each equipment. Each panel unit in the cabinets, and each component secured to the inside of the cabinets (such as delay lines, RF Filters, and similar items which may be part of the cabinet) shall have a nameplate carrying name and model of the equipment, unit or subunit name, type number, and serial number. Prior to completion of nameplate design drawings, the contractor shall furnish the USAF with a summary of the equipment units, together with suggested names, so that type and serial numbers can be assigned. Requests for nomenclature shall be made in accordance with MIL-N-7513.

3.15 Workmanship.- Workmanship standards shall be in accordance with MIL-W-27076.

3.16 Design approval.- Construction shall not begin on any component until the USAF has granted a formal design approval for that component. Approval or disapproval of the design submitted will be based on an engineering evaluation of a component design approval package. One component package shall be submitted for each group and component, and shall contain a separate section on each assembly or module. All such packages shall be submitted no later than 120 days after award of contract. Each package shall include enough detailed schematic diagrams, prints

of layouts and packaging, estimated MTBF and MTR calculations, and technical narration, to permit an engineering evaluation of the extent to which the proposed component design and construction conforms to the requirements.

## SECTION IV

### QUALITY ASSURANCE PROVISIONS

4.1 Responsibility for inspection.- Unless otherwise specified herein, the contractor is responsible for the performance of all inspection requirements prior to submission for USAF inspection and acceptance. Except as otherwise specified, the contractor may use his own facilities or any commercial laboratory acceptable to the USAF. Inspection records of the examinations and tests shall be kept complete and available to the USAF as specified in the contract or order. The USAF reserves the right to perform any of the inspections set forth in the characteristic where such inspections are deemed necessary to assure that supplies and services conform to prescribed requirements.

4.2 Classification of tests.- The inspection and testing of the AN/TRN-( ) shall be classified as follows:

- a. Preproduction tests - (reference paragraph 4.3); and
- b. Acceptance tests - (reference paragraph 4.4).

4.3 Preproduction testing.- Preproduction testing shall be performed on three identical preproduction AN/TRN-( ) sets, which were designed, fabricated, and constructed in parallel prior to assembly as a complete set. The electronic components listed under paragraph 3.8 of this characteristic shall be given temperature and electrical tests over the complete environmental range, herein specified, to determine that the components meet the design and construction practices, as well as the electronic parameters specified in Section III of this characteristic. Upon satisfactory completion of component tests, the components



shall be assembled as three complete sets and subjected to a standard ambient condition test in accordance with MIL-STD-810. If the pretest performance records of all three sets correspond within the tolerances of this characteristic, and if a visual and mechanical inspection shows that the sets physically correspond to each other, then all three sets shall be utilized in fulfilling the preproduction test requirements just as if the three sets were the same set. In other words, different portions of the preproduction test may be run on each of the three units (in parallel) until, between the three sets, all of the tests have been completed, even though each set has only undergone some of the tests. However, no preproduction tests shall begin until the three sets have achieved the degree of correspondence specified herein. The preproduction testing shall consist of:

- a. Performance tests (reference paragraph 4.3.1),
- b. Environmental test (reference paragraph 4.3.2); and
- c. Reliability tests (reference paragraph 4.3.3).

4.3.1 Performance tests.- The preproduction units chosen under the sampling plan described in this characteristic shall be subjected to the individual tests of paragraph 4.4.1 contained herein.

4.3.2 Environmental tests.

4.3.2.1 Reference performance test.- A pretest performance record will be made as described in paragraph 4.3.4 of this characteristic.

4.3.2.2 Extreme temperature tests.

4.3.2.2.1 Low temperature tests.- The AN/TRN-( ) shall be subjected to a low temperature test in accordance with MIL-STD-810, Method 502, Procedure I. The operating portion of the test shall be conducted at temperatures specified in paragraph 3.3.14.

4.3.2.2.2 High temperature tests.- The AN/TRN-( ) shall be subjected to a high temperature test in accordance with MIL-STD-810, Method 501, Procedure I. The operating portion of the test shall be conducted at temperatures specified in paragraph 3.3.14. During the operating portion of the test, the internal hot-spot temperatures shall be measured with thermocouples (or other heat sensing devices) to insure that the temperatures are within design limit for the equipment and that the blowers are furnishing an adequate flow of air. This portion of the test shall be accomplished with shelter doors closed and the ventilating fans operating.

4.3.2.3 Altitude tests.- The unit, placed in its normal operating position in an altitude chamber, shall be tested as follows: (To check temperature stabilization, place a thermocouple on the largest internal mass centrally located within the equipment.)

4.3.2.3.1 Low altitude test.- Reduce the barometric pressure to  $20.6 \pm 0.1$  inches of mercury (simulated 10,000 ft. above sea level) and, after temperature and pressure stabilization, repeat the test specified in paragraph 4.3.2.1. The unit shall meet specified performance for this test.

4.3.2.3.2 High altitude.- Remove the power from the unit and further reduce the barometric pressure to  $4.3 \pm 0.1$  inches of mercury (simulated 50,000 ft. above

sea level). Maintain this condition for one hour. Return the chamber to ambient pressure. Apply power to the unit and after power and temperature stabilization, repeat the test specified in paragraph 4.3.2.1. The unit shall meet specified performance for this test.

4.3.2.4 Rain test.- The shelter, while housing the equipment, shall be subjected to a rain test in accordance with MIL-STD-810, Method 506, Procedure I.

4.3.2.5 Humidity test.- The AN/TRN-( ) shall be subjected to a humidity test in accordance with MIL-STD-810, Method 507, Procedure I.

4.3.2.6 Salt-fog test.- The AN/TRN-( ) shall be subjected to a salt-fog test in accordance with MIL-STD-810, Method 509, Procedure I.

4.3.2.7 Sand and dust test.- The antennas, mounted on their masts, and the AN/TRN-( ) shelter, housing the equipment with the door in a closed and a latched condition, shall be subjected to a sand and dust test in accordance with MIL-STD-810, Method 510, Procedure I.

4.3.2.8 Fungus test.- Selected samples of the AN/TRN-( ) parts and modules shall be subjected to a fungus test in accordance with MIL-STD-810, Method 508, Procedure I. The samples shall be representative of the entire AN/TRN-( ) and shall be parts and modules that are likely to be damaged by fungus in accordance with the list of typical materials in MIL-STD-810, Method 508.

4.3.2.9 Sunshine tests.- The AN/TRN-( ) in operating configuration, shall be given a sunshine test in accordance with MIL-STD-810, Method 505, Procedure I.

4.3.2.10 Shock tests.- The AN/TRN-( ) in transport configuration, shall be subjected to shock tests in accordance with MIL-STD-810, Method 516, Procedure III, Steps b, c, and d.

4.3.2.11 Vibration tests.- Selected equipment from the AN/TRN-( ) (reference paragraphs 4.3.2.11.1 and 4.3.2.11.2) shall be subjected to vibration tests in accordance with MIL-STD-810, Method 514. The test shall include sinusoidal resonance and cycling tests. Equipment that is primarily electronic shall be tested in accordance with Equipment Class 5, Mounting B, as specified in table 514-I; equipment that is primarily mechanical shall be tested in accordance with Equipment Class 5, Mounting A. Sinusoidal test curves shall be as shown in figure 514-5. Time for resonance tests shall be in accordance with schedule III of table 514.II.

4.3.2.11.1 Selected mechanical equipment to be subjected to vibration tests shall include:

- a. One complete antenna, TACAN;
- b. One complete antenna, monitor, TACAN; and
- c. One mast for antenna, TACAN.

4.3.2.11.2 Selected electronic equipment to be subjected to vibration tests shall include:

- a. One transponder cabinet, complete with its normal complement of transponder equipment; and
- b. One common equipment cabinet, complete with its normal complement of common equipment.

4.3.2.12 Ice test.- The AN/TRN-( ) shall be capable of operation and storage with two inches of ice, radial, on any exposed surface with the exception of the antenna surface.

4.3.2.13 Wind test.- The AN/TRN-( ) shall be capable of operation and storage in winds of 80 knots from any horizontal direction, with gusts to 100 knots. Although no permanent damage shall result, there may be some minor degradation of accuracy above 60 knots.

4.3.2.14 Interference test.- The AN/TRN-( ) shall be subjected to interference tests to demonstrate that it complies with the requirements of MIL-I-26600, with Amendment 2 and Notice 1.

4.3.3 Reliability tests.- Reliability tests shall be conducted at prevailing environmental conditions.

4.3.3.1 The AN/TRN-( ) shall be placed into continuous operation in the configuration specified for the ambient temperature performance test, with all components performing as required. It shall be operated for a period of time in accordance with Condition Number 1 and Table I, of MIL-R-26474. A detailed record shall be kept of each failure and interruption.

4.3.3.1.1 A failure is defined under the AN/TRN-( ) reliability and maintainability requirements (reference paragraph 3.6.4.2).

4.3.3.1.2 An interruption is defined under the AN/TRN-( ) reliability and maintainability requirement (reference paragraph 3.6.4.2.2).

4.3.3.2 The AN/TRN-( ) shall be considered to have successfully completed the reliability test if the equipment meets the requirements of Condition Number 1 and Table I of MIL-R-26474.

4.3.4 Pretest record.- Each AN/TRN-( ) that is to be subjected to environmental tests shall first be operated at standard ambient conditions and a pretest performance record made in accordance with MIL-STD-810.

4.3.5 Failure and retest.- In the event that a set fails a particular test, that same set shall be required to successfully complete a retest of the test it failed. Any modifications or design changes made as a result of failures shall immediately be made in all three preproduction sets before any of them start a new test.

4.3.6 Preproduction test report.- Testing of the preproduction models shall be documented by furnishing the procuring activity with 12 copies of a Preproduction Test Report, prepared in accordance with MIL-T-9107 (USAF), with Amendment 2.

4.3.7 Acceptance of preproduction sets.- Following completion of preproduction testing, each preproduction set, after refurbishing, shall be subjected to a complete acceptance test prior to acceptance by the Government.

4.4 Acceptance tests.- Acceptance tests shall consist of:

- a. Individual tests (reference paragraph 4.4.1); and
- b. Sampling tests (reference paragraph 4.4.2).

4.4.1 Individual tests.- Each AN/TRN-( ) shall be subjected to individual tests for examination of product and functional tests. All individual tests shall be conducted under prevailing environmental conditions, unless specified otherwise.

These individual tests shall be conducted on each item produced (100 percent inspection). No set shall be accepted until it has successfully completed these individual tests. The individual tests shall consist of:

- a. Inspection tests (reference paragraph 4.4.1.1);
- b. Electrical performance test (reference paragraph 4.4.1.2); and
- c. Mechanical performance test (reference paragraph 4.4.1.3).

4.4.1.1 Inspection tests.- Each AN/TRN-( ) shall be given a thorough mechanical and visual inspection test to determine that the quality of material, construction, and workmanship are in compliance with requirements. The inspection test shall include an inspection with AN/TRN-( ) in the transport condition; an inspection while the equipment, that is normally removed from the shelter for installation, is being so removed; and an inspection when all such equipment has been removed. Particular attention shall be given the following:

- a. Completeness;
- b. Nameplates, markings, and labels;
- c. Accessibility of components for maintenance;
- d. Safety of personnel from shock;
- e. Cable assembly connections;
- f. Storage facilities and tiedowns;
- g. Finishes;
- h. Welds;
- i. Solder joints;
- j. Test points;
- k. Lubrication and rust prevention;
- l. Grounding facilities;
- m. Dimensions;



- n. Weight;
- o. Conformity to standard parts; and
- p. Other visible defects.

4.4.1.2 Electrical performance tests.- Each AN/TRN-( ) shall be set up in its normal operating configuration. Proper input power shall be provided, and the circuit breakers and switches shall be thrown to their normal operating position. The following inspections and measurements shall then be made to determine that the electrical design, construction, and performance of the AN/TRN-( ) is in compliance with the requirement:

- a. Inspect for:
  - (1) Proper functioning of all circuit breakers
  - (2) Proper functioning of all interlocks
  - (3) Proper functioning of all meters
  - (4) Proper functioning of all lamps and other status indicating devices. The remote control assembly shall be connected and inspected following inspection of the local control panel.
  - (5) Proper functioning of all switches, particularly transfer switches.
  - (6) Proper functioning of all controls, particularly tuning controls.
- b. Using independent calibrated test equipment, not part of the AN/TRN-( ), measure:
  - (1) That the operating voltage at all test points and other significant points conforms to the requirements, where specified, to the circuit labels, where present, and to the schematic drawings.
  - (2) The functions and parameters normally monitored by the AN/TRN-( ) monitor (reference paragraph 3.8.3), and compare the readings

with those of the governing monitor and the non-governing monitor. All three measurements of each function shall agree within the specified tolerances for each function.

- (3) That the RF pulse spectrum conforms to the requirements of this characteristic. This measurement shall be made on channels 1 and 126, plus three other channels selected randomly and individually for each set.
- (4) That the PRF does not deviate beyond specified tolerances for the conditions of no load, full load, and CW interference as required by this characteristic.
- (5) That the radiation pattern of the TACAN antenna shall conform to the pattern requirements of this characteristic (reference paragraph 3.8.2). This measurement may be made on the antenna separately if prior approval is obtained from the procuring activity.
- (6) That the system channel change (short tune-up) can be completed in less than 10 minutes.

4.4.1.3 Mechanical performance test.- Each AN/TRN-( ) shall be given a thorough mechanical test to insure compliance with the mechanical requirements of this characteristic. This test shall include, but not be limited to, trials to demonstrate the ease and completeness of operation of gears, cranks, sliding parts, turrets, winches, connectors, cabinet drawers, etc.

4.4.2 Sampling tests.- Sampling tests shall be conducted under prevailing environmental conditions unless specified otherwise. Sampling tests shall consist of the requirements contained in paragraphs 4.3.1, 4.3.2, 4.3.3, 4.3.4 and 4.3.5 of this characteristic.

4.4.2.1 Periodic sampling.- AN/TRN-( ) sets, selected in accordance with the following schedule, shall be subjected to the required sampling tests. This schedule refers only to production sets; therefore, set number one in the table is the first set produced following the three preproduction sets.

SAMPLING SCHEDULE

Consecutively Produced Sets	Quantity of Sets to be Tested
1	1
2 - 8	1
9 - 20	1
21 - 35	1
Over 35 (for balance of order)	One of each 20

4.4.2.1.1 Rejection and retest.- When an item selected for a sampling test fails to meet the characteristic, no items still on hand or later produced shall be accepted until the extent and cause of failure have been determined and appropriately corrected. The contractor shall explain to the USAF representative in writing the cause of failure and the action taken to preclude recurrence. After correction, the tests shall be continued from the beginning of the test in which the failure occurred.

4.4.2.1.2 Continuation of some tests.- Individual tests or sampling tests other than the one on which the reject occurred, may be continued pending correction of cause of sampling test failure; however, no further sets shall be accepted until correction of fault has been substantiated by a successful retest.

4.4.2.1.3 Defects in items already accepted.- The investigation of a test failure could indicate that defects may exist in items already accepted. If so, the contractor shall fully advise the procuring activity of all the defects likely to be found and the method of correcting them.

4.4.3 Maintainability.- Data shall be collected and maintained for each failure and interruption occurring during all phases of test. The data shall include the following times which shall be used as the basis of determining compliance to the maintainability requirements of paragraph 3.6.4, et al.

- a. Fault location time;
- b. Active repair time;
- c. Check-out time; and
- d. Preventive maintenance time.

NOTE: The finite ground rules for the performance of the demonstration test shall be as mutually agreed by the procuring agency and the contractor.

4.5 Operational data.- The following operational data shall be supplied by the contractor to the procuring agency at least 30 days prior to the start of acceptance tests.

- a. Twelve copies of a cabling diagram of the AN/TRN-( ).
- b. Twelve copies of outline dimensional sketches of all major and minor assemblies and any detailed parts not internal therein, showing projections.
- c. Twelve copies of a brief instruction manual. The manual shall cover all installation and operating procedures necessary to enable skill level 5, or equivalent, personnel to perform operational suitability tests on the AN/TRN-( ). The manual shall also include any information required for the maintenance of contractor furnished equipment.
- d. Twelve copies of a practical wiring diagram of each contractor-furnished component or of each constructional unit thereof, whichever is practical, showing the physical location and connections of detailed parts and sub-assemblies with reference symbols and terminal numbers indicated.

4.6 Inspection and preservation.- Sample items or packs and the inspection of the preservation, packaging, packing, and marking for shipment and storage shall be in accordance with the requirements of Section V of this characteristic.

4.7 Test plan.- The contractor shall prepare and submit to the procuring agency for review and approval, at least 90 days prior to the start of test, a detailed test plan describing procedures, test equipment to be used, and records to be kept during the conduction of all tests specified in Section IV. All test equipment to be used shall be identified by manufacturer and type or military identification.

4.8 Acceptance test report.- Each acceptance test shall be documented by the submission of three copies of an acceptance test report in accordance with MIL-T-9107. The report shall be of the summary type, except when the report describes a sampling test, in which case it shall be a complete and thorough report with separate sections describing the environmental and reliability tests.

4.9 Failure data reports.- Detailed failure data records shall be kept for each set such that any failures during the testing of that set are documented. Failure data reports shall be submitted every 60 days and shall include a cumulative summary, as well as the current records.

4.10 Refurbishing.- The contractor shall refurbish the equipment used as test samples so that they shall be identical to other items delivered under the contract.

SECTION V

PREPARATION FOR DELIVERY

5.1 Preparation for delivery.- Preparation for delivery shall be in accordance with the instructions of the procuring activity.

## SECTION VI

### NOTES

6.1 Intended use.- The beacon-transponder set is intended for use as a navigational aid facility, which will furnish accurate bearing and distance information on any of the 126 TACAN channels to up to 100 aircraft instrumented with TACAN airborne equipments. Other intended uses are as follows:

- a. As a highly mobile air-transportable TACAN navigation facility, which would fulfill all of the needs of the EMS program and the requirements of the USAF.
- b. As an augmentation to AN/MRN-7 and AN/MRN-8 instrument landing system to provide continuous distance information to aircraft, in addition to or in lieu of middle and outer marker beacons.
- c. As a highly efficient facility to provide quick reaction capabilities to any military action involving aircraft.
- d. As a portable or permanent back-up facility for use under commercial, as well as military, disaster conditions.
- e. As a portable back-up facility for use during major maintenance activities.

6.2 Ordering data.- Procurement documents shall specify the following:

- a. Title, number, and date of this characteristic.



- b. Quantity of transporters per system, consisting of:
  - (1) Dolly, trailer, front (V-266/TSQ-47)
  - (2) Dolly, trailer, rear (V-265/TSQ-47)
- c. Requirements for preproduction testing.
- d. Waivers for preproduction testing, if selected source has delivered identical equipment on prior procurements. Source selected must show adequate proof in terms of test report, acceptance forms, source suppliers for equipment components, and production units.
- e. Requirements for the use of standard parts and preferred parts lists.
- f. Conditions under which design approval will be granted.

6.3 Complete type designation.- For the type designation with parentheses, the parentheses will be either removed or replaced by a letter. This information will be furnished after each contract has been awarded, upon application by the contractor to the procuring activity. The complete nomenclature or type number (with the letter and without parentheses) will be used on nameplates, shipping records, and in instruction books as applicable.

6.4 First article approval.- The first article of each component, as well as the first complete system of the facility and equipment, shall be inspected and approved by the cognizant technical activity prior to the fabrication of the balance of equipment of the contract. This shall include inspection and approval of mechanical construction, as well as electrical and system performance. Approval should be based on first article tests, as described in Section IV of this characteristic,

but approval or partial approval for fabrication may be granted by the procuring activity prior to completion of first article tests.

NOTICE. When Government drawings, specifications, or other data are used for any purpose other than in connection with a definitely related Government procurement operation, the United States Government thereby incurs no responsibility nor any obligation whatsoever; and the fact that the Government may have formulated, furnished, or in any way supplied the said drawings, specifications, or other data is not to be regarded by implication or otherwise as in any manner licensing the holder or any other person or corporation, or conveying any rights or permission to manufacture, use or sell any patented invention that may in any way be related thereto.

APPENDIX II

PROGRESS REPORT #1

(Start of Contract Through the First Week in November 1963)

Contract No. AF19(628)-3263

CORRECTED COPY

## MEMCOR/MONTEK DIVISION

MEMCOR

MODEL ENGINEERING &amp; MANUFACTURING CORP.

January 16, 1964

4438 SOUTH STATE STREET  
SALT LAKE CITY, UTAH 84107

Electronic Systems Division  
Air Force Systems Command  
United States Air Force  
Laurence G. Hanscom Field  
Bedford, Massachusetts

Attention: Mr. Cornelius Lennon, Contracting Officer

Subject: Contract No. AF19(628)-3263  
Progress Report #1

Gentlemen:

The following is a statement of findings and significant results obtained by the MONTEK field engineering team as a result of the performance under the terms and conditions of the subject contract. The progress is defined through the first week in November.

Significant results of MONTEK's evaluation are as follows:

I. TRANSPONDER TEST BED

- A. The peak power output of the transmitter measured by a TS-118A/AP watt meter was low (approximately 25 watts). The peak power remained low after replacement of the klystron and retuning of the transmitter. Finally a short RF line section in the transmitter system was discovered to be missing. When the line section was replaced, 8.11 KW peak power was noted at the output.
- B. The antenna control circuitry operated erratically causing sporadic rotation of the antenna. Tests isolated the problem in the pre-amplifier section of the antenna control unit. Output voltage of the magnetic amplifier was -0.5 volts D.C. It should have been -1 to -10 volts D.C. Replacement of the pre-amplifier indicated output control voltage of -3.2 volts D.C. and the antenna thereafter rotated properly.
- C. An arcing problem was isolated in the "AMP-MOD" drawer. A ground bus-wire was located in too close a proximity to the high voltage bus discharge resistor (R1325). The problem was corrected by repositioning of the ground bus.

- D. Lamination vibration within the transformer caused excessive noise in the klystron filament transformer. Replacement of the transformer caused a cessation in the spurious vibrations.
- E. During routine tests, two small nuts and one screw were found within the antenna radome. However, the source of these parts was unknown. The radome base plate was observed to be scarred; however, it was learned that the damage had been caused prior to installation.
- F. On 24 September 1963, the antenna tachometer belt was found to be broken. The main antenna drive belt was observed to have bad weather cracks; hence, both belts were replaced. Prior to replacement of the belts, the reference pulses exhibited poor stability. When the tachometer belt was replaced, the stability of the reference pulses improved.
- G. On 1 October 1963, a 1/4 wave stub monitor antenna was fabricated and installed adjacent to the AN/URN-3 antenna for radiated signal pickup, which was needed in solid-state monitor integration.
- H. The identification keyer coder switch located in the coder indicator unit and mounted on the coder wheel assembly was replaced. The switch was replaced due to excessive reduction in duty cycle during identity transmission period. Readjustment of the original switch was unstable and unsatisfactory.
- I. A convenient method of switching the transmitter output power between a dummy load and the antenna was necessary for testing purposes. A coaxial switch (SA-420) was available and had the necessary connectors and features for the operations needed. Also, connectors were available for the test equipment that is associated with the AN/URN-3 Transponder Test Set. The coaxial switch was connected, and is functioning satisfactorily.

## II. SOLID-STATE (1 KW) TACAN TRANSMITTER

- A. The solid-state transmitter and the associated power supplies were received from Maxson Electronics on 8 August 1963. Due to the packaging technique used on the power supplies which were enclosed in a standard 19" steel cabinet, the high voltage power supply front panel was damaged in shipment. The damage consisted of a severely buckled front panel. A large, sola constant voltage, transformer was supported by the front panel and by metal brackets mounted on the high voltage power supply chassis. Evidently, the bolts had come loose from the metal brackets; hence, the sola transformer was supported solely by the high voltage supply front panel.

Mr. Arnold Rosen from Maxson Electronics repaired the power supply damage and checked out the remaining transmitter system. When the Maxson representative left, the transmitter was producing pulses with a peak power output of approximately 1 KW with the spectral feedback loop disconnected.

- B. Spurious oscillations resulted when the feedback loop was connected. Mr. Rosen suggested increasing the attenuator pad, located in the feedback loop, from 3 db to 10 db in order to reduce the detected video pulse to approximately 1 V peak. A 10 db pad was not available at the time; hence, the feedback loop was not connected.
- C. An adequate spectrum analyzer is not available to date; however, a TS-890 (AN)/URN-3 has been ordered through Air Force channels and is expected to be delivered soon.
- D. The following problems with the power supply network have been encountered:
1. The high-voltage, current sensitive relay contacts for the +700 V supply were intermittent. An adjustment of the contact spacing as well as cleaning of the contacts was necessary to correct the problem.
  2. The inner conductors of the high voltage cable are larger than the connecting pins of the high voltage connectors. Breakage of the connections to the high voltage connectors was quite frequent. Steps have been taken to support the high voltage cable and extra care taken when working around the cable. (Replacement of the cable and/or connectors is being considered.)
  3. The -20 V supply was noted to increase to -30 V when the system was operated for 6-7 hrs. The voltage increase was due to insufficient air circulation around the power supplies; thus, the ambient temperature within the power supply cabinet was higher than the maximum operating temperature for which the power supply was designed. By leaving the rear door to the power supply cabinet open, air circulation was increased, returning the -20V supply to normal -- permitting transmitter testing to be resumed.\*
- E. When 10 and 14 db pads were acquired work immediately began on the evaluation of the spectral feedback loop within the transmitter. Replacement of the 3 db pad with the 14 db pad resulted in a detected video output pulse of approximately 1 V peak. The detected video pulse was applied to one input of the difference amplifier. The other remaining input of the difference amplifier accepts output pulses from the reference generator. An error signal with a minimum adjustable amplitude of 200 mv was noted at the output of the difference amplifier. The final report issued by Maxson states that the maximum error signal from the difference amplifier should be equal to or less than 30 mv peak. When monitoring the error signal at the output of the first video amplifier, the error signal was distorted due to saturation of the first video amplifier.

\*NOTE: The power supplies provided with the solid state transmitter consist mainly of commercial off-the-shelf power supplies mounted in a standard 19" rack. Apparently, little if any effort has been expended in light-weight, compact power supply development for this transmitter.



A test was conducted to determine the maximum amplitude of a signal which could be applied to the input of the first video amplifier, such that no saturation would occur at the output. Tests concluded that a maximum signal of 11 mv p/p could be applied to the input of the first video amplifier before saturation would occur. During the test, a 150 kilohm 1/2 watt resistor was used to attenuate the difference amplifier error signal to some value less than 11 mv p/p.

Maxson's final report also states that the amplitude of the error signal on the grid of the RCA 7649 R.F. output tube should be 200-300 volts to control the system gain. Tests indicate that the maximum error signal that the output video amplifier could pass before the output signal distorted was approximately 100 V p/p. With only 100 V of signal voltage on the grid of the final R.F. amplifier, partial control of the output signal would perhaps occur.

In addition to the distortion of the error signal from overdriven amplifiers, the error signal appeared to be distorted due to insufficient frequency response of the feedback loop. A frequency response test was conducted on the first video amplifier and on the output video amplifier. The bandwidths of the first video amplifier and final video amplifier were 2 mc and 4 mc respectively. The bandpass of the two amplifiers was sufficient in frequency response; however, a 9100 micro micro farad capacitor had been connected by Maxson between the grid of the last RF amplifier stage and ground. The capacitor was connected directly across the output of the final video amplifier. With the capacitor connected as above, the bandpass of the feedback loop dropped to 250 kc. The capacitor was then disconnected from the feedback loop circuit. Since the feedback loop was not satisfactory, (i.e., the output waveform would not follow the reference waveform), the output waveform from the transmitter is being controlled solely by the cathode modulation of the individual RF amplifier stages. A work outline has been completed to provide additional work on the feedback loop and is proceeding satisfactorily.

- F. A problem has been noted in adjustment of the first cavity of the RF amplifier chain. When adjustments are made, the signal from the cavity is very erratic. The problem seems to be either mechanical or electrical shorts within the cavity.

Another problem noted with the cavities is that each input and output probe of the cavities is adjusted for maximum coupling.

The grid of the last RF amplifier cavity is connected directly to the cavity shell. The shell of the cavity is held at -65V DC. Adjustment of the cavity causes a minor electrical shock hazard. Also, since there is no shielding around the cavity, this floating cavity radiates a considerable amount of RF energy. A small signal pick-up loop and diode circuit was constructed to detect radiated RF energy. Radiated signals with amplitudes of 100 V were observed in the location of the output



cavity. The radiation is so great that the reference and output detected waveforms distort when people are working in and around the transmitter. The problem here is quite serious, since it results in distortion of the reference pulse. The reference pulse must remain constant if the output waveform of the transmitter is to remain within the limits of the specification.

- G. Intermittent loss of signals within the transmitter was affecting the output power. Interconnecting cables were found to be shorting internally. The inner conductors were shorting through the inner insulation to the outside shielded cables. Replacement of the shorted cables eliminated the problem. Also, many "BNC" cable connectors had been installed backwards by the vendor. The installation error would damage the outer shield and produce shorting. Complete rewiring of the system, including all connectors, was examined and repaired where necessary.

With the transmitter producing apparently suitable pulses and with a peak power of 1 KW, the sides were installed. The peak output power dropped to 200 watts, the output pulse distorted, and the reference pulse was unrecognizable. Evidently, due to large amounts of RF radiation, poor grounding techniques, insufficient modular shielding, and poor RF suppression, the sides cannot be installed at the present time. Rerouting of connecting cables was to no avail. Some shielding techniques were attempted with no satisfaction.

- H. A test was conducted to determine the total efficiency of the transmitter and related power supplies. An averaging input A.C. current of 19 amps @ 114 rms was recorded; hence, the total input power is approximately 2165 watts. The average generated output power, for a 1 KW peak power reading @ 3600 pulse pairs/sec was 23 watts; therefore, the total efficiency of the transmitter and the associated power supplies is slightly less than 1%. By replacing a number of tubes in the system with solid-state (transistors), the efficiency would be increased, since filament power dissipation would be reduced.

The philosophy upon which this transmitter is based and variations of this philosophy, i.e., driving solid-state diode modulators with a controlled and shaped video pulse, is worthy of further investigation. It appears that such a philosophy will lead to a small and light-weight TACAN transmitter possessing an adequate frequency spectrum without the use of mainline RF spectrum filters.

### III. SOLID STATE TACAN MONITOR

#### A. GENERAL PROBLEMS: SCHEMATICS VS AS-BUILT CIRCUITRY

1. Symptom and Source: In testing and adjusting different modules, many points had to be located. In many cases the circuitry did not agree with the schematics and the desired points were hard to find. All of the circuits were compared with the schematics. In each case when discrepancies occurred the circuit function was analyzed to determine whether the circuits or the schematics were in error.

In areas where circuitry had been added or deleted, appropriate documentation was made on the schematics by the team. As the circuit/schematic comparison was being made, some components were found to be incorrectly connected.

B. WORKMANSHIP

The operation of various circuits was unpredictable. One moment the waveform at a certain point was of a particular shape and size while a moment later the shape and size often changed. The problem appeared to be a result of bad solder connections so the complete circuitry was analyzed for such defects. Throughout the monitor circuitry, 37 bad or no solder joints have been found and corrected.\* The majority of the faulty joints were unsoldered.

C. FUNCTIONAL PROBLEMS: ONE-HALF AMPLITUDE MODULE

1. Operation of Switch #401: The input signal to transistor Q401 would not change when Potentiometer R401 was adjusted. Upon changing the position of Switch #401, the input signal to Q401 was either of a fixed amplitude or non-existent regardless of the setting of potentiometer R401.

The switch was found to have been wired incorrectly and was re-wired.

2. Schematic vs Circuitry Problems: While the schematic/circuitry comparison and bad solder checks were made on this module some diodes were found in the circuitry but not on the schematic and vice versa; a transformer was shown with the wrong phasing; some component values were called out differently than were used in the circuitry; a component tolerance was called out different from what was used; and seven bad solder joints were found. Two of the bad solder joints caused a catastrophic failure of two transistors.
3. Amplitude of Input Signal (Composite Line): The amplitude of the output signal to the peak power module was too low even with minimum input attenuation resulting from the fact that the composite signal from the URN-3 transmitter directional coupler was too low.

A two-stage amplifier was designed to provide sufficient gain and proper phasing. Later on, a coaxial switch (SA-420) with signal couplers that could be adjusted to couple a larger signal from the transmitter was connected to the URN-3 transmitter output. With the larger signal available, the use of the two-stage amplifier was discontinued.

\* NOTE: The solution to this problem was carried out concurrently with Problem #1.

4. Under-rated Resistors: Two resistors were operating at a temperature which was obviously too hot. They were 1/4 watt resistors and were dissipating 0.6 watts. As a solution to the problem, the value of one resistor was increased to cause a decrease of current through the resistors, and the size of the resistors was increased to 1/2 watt. \*

D. FUNCTIONAL PROBLEMS: PERCENT RESPONSE/REPLY DELAY/PULSE SPACING MODULE

1. Percent Response Meter Wired Up Backward: The percent response meter would not indicate the presence of a signal. The meter remained pegged down scale and could not be adjusted out of the pegged condition. The dc signal necessary to trigger unijunction transistor Q314 had to be positive. The voltage at the emitter of Q318 was positive with respect to the voltage at the anode of CR316. Investigation showed the meter to be connected backward with the meter leads reversed.
2. Over-driving Meter: With a pulse rate of 100% response and minimum meter sensitivity, the meter still read off scale (full scale end). The meter was being driven with 75 micro amps, while full scale deflection occurred with a drive of 50 micro amps. To solve the problem, R362 was increased to reduce the drive current.
3. Alarm Light Activates Too Soon: The lowest alarm threshold that can be attained with adjustment R351 is approximately 80% of full scale. The trouble appears to be caused by an insufficient adjustment range attainable with R351. At this time it remains uncorrected.
4. Timing Problem: No signal response was indicated on the meter, and no pulses out of the "AND" gate involving CR315 were present. The lack of this signal resulted from the delayed interrogate pulse, 0.9 microseconds wide, which was occurring too soon with respect to the beacon response pulse. The maximum pulse width is 2.8 microseconds. The ALC, RF Gen. and 1/2 amplitude modules create a time lag of approximately 3.4 microseconds, which had not been accounted for. The monitor delay can only be varied approximately 0.75 microseconds.

The monitor delay was increased sufficiently to properly time the delayed interrogate pulse.

5. The Reverse Bias Voltage Was Too Great: Q304 was electrically ruined twice.  $BV_{eb}$  maximum was approximately 6 volts. To resolve this problem, the reverse voltage was reduced.

\* NOTE: All of the problems in the 1/2 amplitude module have been resolved. It is now operating and ready for specification tolerance testing and evaluation.

6. Percent response meter reading drops to 20% and alarm light goes on when ident occurs. During ident, the monitor interrogate pulses are blocked. The lack of pulses during ident allow voltage discharge to drop too low.

This problem has not been corrected, but will be with either digital or analog circuitry.

E. FUNCTIONAL PROBLEMS: ALC/MODULATOR MODULE

1. Circuitry vs Schematic: Certain portions of circuitry as described on the schematic could not possibly operate. It was necessary to trace the circuitry to determine the circuit configurations used in this module. Different circuitry was also found to exist in the module.

Work is continuing on this module. Fairly complex problems exist here; however, real progress is being made and solutions are forthcoming.

2. Insufficient Output Signal from RF Generator: Variation of Potentiometer R702 does not change the amplitude of the signal which is fed to the RF generator, because amplitude of the input signal was not great enough to drive the existing circuitry with sufficient power to alter the amplitude of the output signal to the RF generator.

F. FUNCTIONAL PROBLEMS: RF GENERATOR

1. Circuitry vs Schematic: The circuitry in the RF generator had been changed so much that it could hardly be identified by the schematic. The additions and deletions of the circuitry were noted. The schematic indicated that a +150 volts dc supply was used; however, tests show that +230 volts dc are used on the ceramic triodes.
2. RF Output: The ALC control did not respond to a change in amplitude of the RF output signal. The RF generator had to be tuned by first removing the bottom from the generator in order to get at each stage. Then by tuning each stage beginning at the oscillator, an output was finally achieved. The bottom cover was then replaced. By monitoring the output, each stage was again tuned up. The final tuning capacitor is mechanically unstable.

With the RF generator tuned properly to channel 78 and under a no load condition, the maximum achievable detected output voltage was 1.4 volts. When the ALC module is connected to the RF generator output, the voltage drops to approximately 0.5 volts. Some circuit re-design is necessary here in order to obtain greater output signal. Progress is being made.

G. FUNCTIONAL PROBLEMS: REFERENCE BURST MODULE

No major problems were found in the operation of this module; however, it should be pointed out that this circuit will not meet the tolerances that are called out in the specifications, i.e., as many as five north pulses per burst could be missing, and the monitor would not alarm.

H. FUNCTIONAL PROBLEMS: IDENTITY AND PEAK POWER MODULE

Improper Gating of Composite Line Feeding Ident Circuitry: Weak output identity signals and reference pulses were noted to exist in the composite line after reference burst gating. Some reference bursts were not removed from the composite line while some squitter pulses were being removed from the composite line.\*

A considerable amount of noise is heard in the ident speaker when ident is not occurring. It should be pointed out that this module does not provide any form of alarm or control and transfer if ident is lost. No problems have been found in the peak power portion of this module.

I. FUNCTIONAL PROBLEMS: SQUITTER RATE MODULE

1. Circuitry Not Completed by the Vendor: The squitter alarm circuitry was not complete and no connection was made between the alarm light and the squitter modules; therefore, the alarm light would not illuminate. The required missing circuitry must be designed and provided.
2. Improper Gate Timing: As was indicated under the "Ident and Peak Power Module" paragraph, the ident tone was weak. Also, some reference pulses were present in the decoded composite line which was fed to the ident module, and some squitter pulses were missing. After the reference bursts are triggered by the reference triggers (from the antenna) in the coder-indicator, the bursts are delayed in the coder indicator and transmitter. These bursts are also delayed in the 1/2 amplitude module as they are being pulse pair decoded. The reference triggers also trigger, with no delay, the reference gates in the squitter rate module. Since the timing is off by approximately 74 microseconds (using the URN-3 test bed), some pulses were gated out which should not have been, while other pulses were passed which should have been gated out. Consequently, false information was fed to the squitter alarm circuitry and the ident module.

To solve this problem, proper delay circuitry was designed and inserted to delay the reference trigger pulses at the input to the squitter rate module.

Many bad solder and no solder joints were found in this module. A resistor was observed to be broken.

\* Reference problems in squitter rate module.



J. FUNCTIONAL PROBLEMS: PERCENT MODULATION MODULE

This module will not reliably provide a test of percent modulation. The circuit detects the peak amplitude of the 135 cps modulating signal.

No monitor antenna was provided with this monitor so the team fabricated a simple 1/4 wave length stub to pick up the AN/URN-3 radiated signal.

K. FUNCTIONAL PROBLEMS: ANTENNA SPEED MODULE

Since this module requires a 1350 cps tone wheel signal (driven by the antenna) and the test bed is an AN/URN-3 which does not have a tone wheel, a test method must be worked out. There has been considerable comment pertaining to an AN/TRN-17 test bed. The AN/TRN-17 antenna contains the tone wheel required. If an AN/TRN-17 is not available, other means for check-out and test of this module must be provided by the four-man team.

If further technical information is required, please contact Mr. Dean S. Thornberg. All matters of a contractual nature should be directed to the attention of the undersigned.

Very truly yours,

MONTEK DIVISION OF MODEL ENGINEERING & MANUFACTURING CORP.



JIM P. HANSEN  
Manager, Contracts Administration

JPH/u

APPENDIX III

PROGRESS REPORT #2

(Second Week of November 1963 through January 1964)

Contract No. AF19(628)-3263

CORRECTED COPY



## MEMCOR/MONTEK DIVISION

MEMCOR

MODEL ENGINEERING &amp; MANUFACTURING CORP.

March 3, 1964

4438 SOUTH STATE STREET  
SALT LAKE CITY, UTAH 84107

234-3

Electronic Systems Division  
Air Force Systems Command  
United States Air Force  
Laurence G. Hanscom Field  
Bedford, Massachusetts

ATTENTION: Mr. Cornelius Lennon, Contracting Officer

SUBJECT: Contract No. AF 19(628)-3263  
Progress Report #2

Gentlemen:

The following is a statement of findings and significant results obtained by the Montek field engineering team as a result of the performance under the terms and conditions of the subject contract covering progress from November 9, 1963, through January 31, 1964.

Significant results of Montek's evaluation are as follows:

I. TRANSPONDER TEST BED

- A. Excessive reduction in duty cycle was noted during the identity transmission period. It was discovered that the identification keyer coder switch on the coder wheel had dirty contacts. By cleaning the contacts, the problem was eliminated.
- B. The transmission of an extra symbol in the ident was detected. To solve this problem, the cam switch on the coder wheel was adjusted to decrease the time in ending ident signal transmission.
- C. No output signal was emitted from the FMO drawer. Investigation revealed that the shaped video pulse was not being generated. The bias voltage on V1201 was -25V, rather than the requisite level of -15V. When the bias voltage of V1201 was restored to -15V the shaped output pulse was noted. Evidently, the change in bias voltage was due to aging of components within the circuitry.
- D. The duty cycle was low and no RF output was detected. It was found that the V1401 tube was weak and was replaced; however, the problem was not corrected by this replacement. Further testing revealed that the buffer Ig current meter reading was low and the keying pulse from the modulator was riding on a high amount of AC signal (100V p/p).

V1209 was found to be broken and was replaced, but the system continued in a state of inoperability. The -375V power supply was measured and found to be -450V with no control available. V1610 was weak and V1611 inoperative (both are within the power supply). Replacement of these components caused the -375V power supply to function properly.

The RF section of the system was then retuned, and the system began operating normally.

- E. The sweep circuit in the OS-54 oscilloscope was inoperable. It was found that a screw which secured the dust and shielding covers was shorting pins 33 and 34 of TB501. The longer screw was replaced with a shorter screw, and the test oscilloscope began functioning correctly.
- F. A TS-890 Pulse Analyzer - Signal Generator, Serial No. 329, was acquired on loan from Weymouth Naval Air Station on December 19, 1963, subject to a 24-hour recall. The unit was returned March 1, 1964.

The spectrum of the AN/URN-3 transmitter was analyzed by the TS-890. After normal calibration procedures of the TS-890 and AN/URN-3 transponder, the TS-890 failed to give approval of the spectrum produced by the AN/URN-3 transponder at all frequency side-bands above and below center frequency. It was noted that the TS-890's temperature controlled crystal frequency was very unstable. When the cover of the crystal oven holder was removed and remained off, the stability would improve considerably. Evidently, the thermostat within the crystal oven does not regulate the temperature correctly.

Work will continue on evaluation of the transmitted TACAN spectrum using the TS-890 as a spectrum analyzer until satisfied results are acquired.\*

## II. SOLID-STATE TRANSMITTER

- A. The transmitter was retuned on channel 78. The transmitted output waveform was adjusted from cavity to cavity resulting in the output waveform overlapping the reference waveform before the error feedback loop was connected. After connecting the error feedback loop, the DC level control of the first cavity was adjusted until the output waveform conformed to that of the reference waveform with one kilowatt peak power generated. The two signals appeared on the oscilloscope to be very similar.

\* NOTE: The problems encountered thus far are typical troubles at any TACAN site. The AN/URN-3 transponder has been operating normally with the exception of minimum down-time while above referenced repairs were accomplished.

The output waveform consisted of the summation of the fundamental waveform, reference shape, and spurious oscillations. The oscillations would tend to cease when copper screening was placed around the output cavity. An NE51 light bulb would remain lit when it was placed in or around the transmitter.

- B. The Hi-Band Power Driver Unit became inoperative when C12 capacitor shorted internally. This condition caused a need for L05 inductor to also be replaced. After C12 and L05 were replaced, the Power Driver operated normally.
- C. Problems with first cavity adjustment dictated the use of the Lo-Band Power Driver Unit; hence, channel 32 is presently being used.
- D. RF arcing was noted around the third cavity tube holder. The tube sockets consist of finger stock, which is relatively brittle. Evidently, installation of the tubes had been effected without exercise of care, causing many of the fingers to break. Broken finger stock in cavities 1-2-3 was replaced. This procedure eliminated RF arcing.
- E. Many of the video and reference coaxial leads were shortened to reduce radiation pickup in the video and referenced circuits. Many of the BNC connectors were found to be erroneously installed, causing the shielding of the coaxial cable to short to the inner conductor.
- F. When the transmitter was triggered by the receiver circuitry, the results were positive. Results obtained verified that a similar solid-state transmitter of this design could be used in a future solid-state TACAN system.

### III. SOLID-STATE MONITOR

#### A. ANTENNA SPEED

A point was located on the AN/URN-3 Antenna Speed Control Unit which provided a signal at the rate of approximately 810 cps. The use of this signal was considered as a replacement for the 1350 cps signal provided by the AN/TRN-17 tone wheel; however, the signal was frequency modulated so poorly, that the use of this signal was impractical. No known method is available for synchronizing on a given cycle.\*

#### B. ALC LOOP

As the previous report indicated, the amplitude of the output signal from the RF amplifier was so small (0.3V peak) that the ALC circuitry could not control the amplitude of the RF pulse. Instead of trying

- \* NOTE: This information is not to be construed to mean that the antenna speed circuitry does not perform as intended. On the contrary, if the circuitry is driven by an audio oscillator at approximately 1350 cps, the function indicator lights up and remains lit until the frequency shift becomes too great.

to get more amplitude out of the RF amplifier, we chose to amplify the detected RF signal, which is fed to the ALC module. The amplifier was designed to provide a voltage gain of 8.7. This added gain was sufficient to satisfy the needs of the ALC loop. This problem occurred when the channel 78 crystal was used.

C. PERCENT RESPONSE CIRCUITRY

The operation of the percent response circuitry was such that the minimum achievable alarm level was 80% (i.e., as the percent response level dropped below 80%, the function light would go out). Also, when ident would occur, the percent response meter would drop to 40%.

The circuitry was altered such that the percent response alarm level could be adjusted to as low as 60% before causing an alarm, and the circuitry response time was delayed to prevent ident from causing an alarm.

D. SQUITTER MONITORING CIRCUIT

As was indicated in the last report, the squitter monitoring circuit had not been provided as part of the solid-state monitor. A small amount of time was expended in an effort to develop a squitter circuit, but in the interest of utilizing contract time on areas of primary contractory responsibility, the squitter circuit was abandoned; however, squitter is being monitored with a digital counter.

E. ONE-HALF AMPLITUDE MODULE

After a coaxial switch (SA-420) was received and integrated into the system, the pickup signal for the one-half amplitude module could be adjusted sufficiently in amplitude that the buffer amplifier, designed and used by the four-man team, was deleted.

F. PERCENT MODULATION MODULE

One of the adjustable potentiometers was used in such a manner that when the wiper was set at one extreme position, several volts were dropped across the emitter-base junction. The result was failure of two components. This problem was eliminated by properly providing a current-voltage limiting resistor to the circuit.\*

IV. SOLID-STATE KEYS

- A. This unit has been placed in operation and preliminary tests have been accomplished. The first indication is that, functionwise, the system operates satisfactorily except for temperature problems in some of the modules. The current drain was monitored during the operation of the keyer, and as the operation continued, the current

\* NOTE: At present, all of the obvious, troublesome problems (except the squitter circuit and the use of the antenna speed circuit of the AN/URN-3) have been resolved. Pictures of pertinent waveforms have been taken. The solid-state monitor has been integrated into the solid-state TACAN system and is monitoring all the functions that it was designed for, with the exception of antenna speed and squitter rate.



drain changed by a factor of approximately 50%. This problem will require investigation to determine a satisfactory solution. Due to its smaller role in the overall system, this keyer has received less attention than the monitor and the transmitter units.

When the keyer was to be integrated into the receiver, it was found the two systems to be incompatible with each other. This condition necessitated an alteration in the keyer output circuitry, as well as modification of associated receiver inputs.

Results: The keyer has been successfully integrated into the receiver, and each function performs as expected.

## V. RECEIVER

- A. The solid-state receiver/coder unit was received 19 November 1963. In terms of the quality of workmanship, its condition was substantially better than that of the monitor. No schematics were provided with the unit; therefore, all the circuits were manually traced and schematics sketched. During the process of circuit tracing, only three connections were found without solder, compared to the large number found in the monitor.

The vendor provided schematics late in December after the receiver/coder was received; however, the final report on this piece of equipment has not yet been received.

### B. CIRCUITRY PROBLEMS ENCOUNTERED

1. IDENT MODULE: Upon integration of the keyer and the receiver circuitry, it was noted that priority of ident over squitter was not established. Since the keyer, as received, was incompatible with the receiver, the ident precedence circuitry had to be modified. The diode blocking circuitry for establishing priority also had to be altered in order to be compatible with the keyer gating circuitry which, likewise, was changed into the squitter function output (or vice versa). The "turn on" and "turn off" gating time had to be increased to prevent the loss of any squitter pulses. As a result of these modifications, the precedence sequence was made to function correctly.
2. NORTH REFERENCE BURST MODULE: The north reference burst circuitry was not being triggered by the north pulses from the antenna (0A-591). After a transistor replacement and the trigger sensitivity increased, the circuitry then began to operate properly.
3. AUXILIARY REFERENCE BURST MODULE: Essentially the same problems were present in this module as in the north reference burst module. A transistor had to be replaced and trigger sensitivity had to be increased to compensate for a weak pulse in the auxiliary trigger pulse train, which is generated by the antenna.

4. DELAY LINE DRIVER MODULE: The delay line driver module functioned properly at the time of the "turn on" test. No information was provided about the delay line.
5. TIMING MODULE: The timing module performed the needed function at the time of the "turn on" test. Since the solid-state transmitter provides its own pulse shaping circuitry, the pulse shaper in the receiver is not used. The input to the shaper was removed from the shaper, and an attenuating resistor was connected from the shaper driver to the transmitter input.
6. IF STRIP: The IF strip does not appear to have the level of gain which has been alluded to by the vendor; however, inasmuch as the final report has not been received, the precise gain value claimed by the vendor is unknown. The overall receiver sensitivity will probably be many db lower than the sensitivity alluded to in the receiver interim report. As with the monitor RF amplifier, initial tuning of the IF strip is very inconvenient. The Ferris discriminator seems to be relatively sensitive to tuning. Also, an intermittent problem exists in the circuitry ahead of the Ferris discriminator amplifier output.

The AGC circuitry is sensitive to AC pickup. Since one transistor stage was thermally unstable, an alteration was made in circuitry to improve the thermal problem.

7. REDUNDANT CIRCUITRY: Apparently during the design and fabrication stages of the transmitter and receiver units, a lack of coordination must have existed between the vendors and USAF. Both the receiver and transmitter units provide a pulse shaping network; whereas, only one unit is necessary. Because of the inherent timing requirements in the system, the pulse shaping circuitry in the transmitter more readily lends itself to system compatibility.
8. DC POWER SUPPLY: The DC power supply is designed such that it overheats to about 80°C. It is not anticipated that an attempt will be made at this time to remedy this problem unless it becomes more serious.

#### C. INTEGRATION PROBLEMS

Since no provisions have been made by the Air Force to supply Montek with a replacement duplexer assembly to replace the AN/TRN-17 (which was never supplied to this contract), the mixer from the AN/URN-3 was tied into the solid-state IF strip. No effort was made to correct for the mismatching occurring between the IF strip and the mixer. With this configuration, the overall receiver gain from the mixer input to the Ferris discriminator output measured approximately 55 db. This test was performed with the use of the TS-890 as the signal generating source.

#### D. MISCELLANEOUS OBSERVATIONS

The interim report indicated that the system would employ the use of a narrow pulse eliminating circuit to prevent radar pulses from affecting the receiver; however, no circuitry of this nature appears to exist.

VI. SOLID-STATE SYSTEM INTEGRATION

A. SYSTEM SUB-UNITS

Several of the components requisite or desirable to the performance of this contract were not provided. This has necessitated that Montek "work around" these units. Substitute approaches are as follows:

1. **DUPLEXER:** Since this contract did not provide for the AN/TRN-17 system as part of the TACAN test bed unit, the solid-state system was lacking a duplexer unit, which was necessary in order to make a complete system. Inasmuch as all avenues for procuring an AN/TRN-17 duplexer system appear to be closed at this time, the team, as an expedient, has used the AN/URN-3 mixer and pre-selector to make performance tests as described below.
2. **SOLID-STATE ANTENNA:** A special antenna was never provided for the solid-state system. The AN/URN-3 antenna, OA-591, has been used throughout the testing of the solid-state unit. Since the "591" antenna does not provide a 1350 cps signal, the 1350 cps signal is simulated with an audio oscillator. The absence of the 1350 cps signal has been the only major problem encountered as a result of not having a special antenna available.
3. **CONTROL AND TRANSFER UNIT:** Receipt of this unit is not anticipated until the completion of the contract, so nothing in this area will be performed until later.
4. **TS-890:** The team was unable to acquire a TS-890 through any of the available sources. Several delivery dates had been promised, but they never materialized; however, with the aid of Mr. Joe Reegan and the Navy, a unit was borrowed from the Navy on a temporary basis. Since the receipt of the TS-890, a number of sensitivity checks have been performed. An attempt will be made to measure the spectrum side bands with the TS-890 prior to the date that the unit is to be returned to the Navy.

B. INTEGRATION OF THE KEYS, RECEIVER, AND TRANSMITTER

By January 16, 1964, the problems in the individual units had been overcome to the extent that each unit operated sufficiently well on a single unit basis. Integration of the whole system was begun on January 16, 1964. The problems encountered are as follows:

1. **GROUNDING SHIELDING:** In order to prevent erratic triggering of the north and auxiliary pulse circuitry, pickup problems, and erratic squitter, careful grounding shielding techniques had to be employed. These efforts were very useful to achieve the proper system operation.
2. **ALTERATION OF RECEIVER OUTPUT:** As mentioned in the receiver paragraph, the shaper circuitry was not used. The receiver shaper driver signal has been disconnected from the receiver shaper circuitry, attenuated, and fed into the transmitter as the driving signal. The transmitter responds well to these driving signals.



3. RECEIVER BLANKING SIGNAL FROM THE TRANSMITTER: This signal as yet has not been tied into the receiver. Without the use of it, taking into account the excessive system delay, the receiver blanking circuitry in the receiver blanks the receiver for approximately 60 microseconds. A small portion of the second output pulse of the pulse pair is still occurring as the receiver blanking signal, created in the receiver, ceases.
4. SYSTEM OPERATIONAL TESTS PERFORMED:
  - a. ARN-21 UNIT RECEIVES BEARING SIGNALS: Previously, a team from RCA had made the ARN-21 unit operative since they needed to interrogate the AN/URN-3 with the ARN-21 as part of their work. After the RCA people had finished their work with the ARN-21, the Montek team used the ARN-21 to receive bearing and ident signals which were transmitted by the solid-state system. This test was first performed January 24, 1964. Channel 32 was used in this test.
  - b. ARN-21 UNIT INTERROGATES THE SOLID-STATE SYSTEM  
Prior to being able to interrogate the solid-state system, the preselector unit from the AN/URN-3 was used as part of the solid-state system. The AN/URN-3 mixer was also used. With this borrowed circuitry from the AN/URN-3, on January 27, 1964, the team succeeded in interrogating the solid-state system with the ARN-21. The ARN-21 would lock-on to the bearing and distance information that it received, as well as emit the ident code that was being transmitted by the solid-state system. From those results, fears concerning feasibility of a solid-state TACAN system should be dispelled.
  - c. MONITOR FUNCTIONS: The monitor has been connected into the solid-state system and has monitored percent response, peak power and reference bursts. Because of the type of antenna being used, the antenna speed monitor was driven by an audio oscillator to simulate antenna speed. Squitter was monitored with a digital counter since the squitter monitor circuitry had never been completed. All monitoring functions, including percent modulation and excepting antenna speed and squitter rate, have been performed on the AN/URN-3 system.
5. EXCESSIVE SYSTEM DELAY: Tests indicate that the minimum adjustable system delay is approximately one microsecond greater than the necessary 50 microseconds. This problem was probably due to an oversight in correlation of work carried out on the receiver and transmitter units. This problem can be eliminated in future solid-state TACAN systems without being burdensome to the circuit designers.

C. OTHER SYSTEM WORK PERFORMED

1. PICTURES: Pictures of most pertinent waveforms have been taken to act as a record and as a guide to help trouble-shoot future problems.

March 3, 1964

Page 9

2. CONFERENCES: A number of conferences have been held with Mr. Joe Reagan in an effort to aid the team in performing their programmed work in a manner that will be of most value to the USAF.
3. SPECIFICATIONS: Work is beginning in the preparation of new TACAN characteristic data for the USAF. Various characteristics are being investigated for the purpose of pointing out areas of both pertinent and obsolete TACAN information which is applicable to future TACAN efforts.

Various state-of-the-art techniques are being investigated in an effort to make the writing of a TACAN characteristic easy and at the same time make it possible to produce a characteristic that can dictate the development of a solid-state TACAN system. It will provide only the features that will improve the flying safety of the pilot.

D. CONCLUSION

Although many problem areas exist in the solid-state TACAN system performance, the feasibility of a solid-state TACAN system has been verified. The team has succeeded in surmounting the many problems that existed in the solid-state system and has achieved system operational success. The team has noted a considerable contrast in the interest of the contractors who provided the solid-state gear. One contractor has made periodic phone calls to see how their gear is responding and is willing to share ideas with the team, while the other contractor is unwilling to discuss information about their gear that should have been proved as part of the final report. With the use of good design techniques, the present problems would be non-existent.

Inquiries of a technical nature should be directed to the attention of Mr. Dean S. Thornberg; matters of a contractual nature should be directed to the attention of the undersigned.

Very truly yours,

MONTEK DIVISION OF MODEL ENGINEERING & MANUFACTURING CORP.



Jim P. Hansen  
Manager, Contracts Administration

JPH/ld1

DOCUMENT CONTROL DATA - R&D		
<i>(Security classification of title, body of abstract and indexing annotation must be entered when the overall report is classified)</i>		
1. ORIGINATING ACTIVITY (Corporate author) Montek Division, Model Engineering & Manufacturing Corp., 4438 South State Street, Salt Lake City, Utah		2a. REPORT SECURITY CLASSIFICATION Unclassified
		2b. GROUP NA
3. REPORT TITLE Solid State TACAN		
4. DESCRIPTIVE NOTES (Type of report and inclusive dates) Final Report		
5. AUTHOR(S) (Last name, first name, initial) Gomm, Thiel J., Steadman, R. Max, Renner, Harold C., and Eder, K. Charles		
6. REPORT DATE September 1964	7a. TOTAL NO. OF PAGES 221	7b. NO. OF REFS 0
8a. CONTRACT OR GRANT NO. AF 19(628)-3263	9a. ORIGINATOR'S REPORT NUMBER(S) Montek Report Number 63-234	
b. PROJECT NO. 482L		
c.	9b. OTHER REPORT NO(S) (Any other numbers that may be assigned this report) ESD-TDR-64-548	
d.		
10. AVAILABILITY/LIMITATION NOTICES Qualified requestors may obtain from DDC Available from OTS		
11. SUPPLEMENTARY NOTES		12. SPONSORING MILITARY ACTIVITY Directorate of Radar & Optics, Hq ESD, L.G. Hanscom Field, Bedford, Mass.
13. ABSTRACT The objective of contract AF 19(628)-3263 was to perform the necessary design, development, and fabrication of circuitry required for integrating the major solid-state components and sub-systems provided by various vendors into an experimental solid-state TACAN transponder beacon and monitor, and to evaluate these components as sub-systems and as a complete TACAN transponder system with monitor. Characteristics (see Appendix I) were also to be provided which would aid the USAF in realizing a complete specification for an advanced solid-state TACAN ground system that would satisfy the present USAF EMS TACAN needs.  The four-man team provided by Montek accomplished the following during the course of this contract: (a) Resolved the problems found in the major solid-state components (sub-systems) previously procured; (b) Solved the interface problems between the solid-state components; (c) Integrated the major components into a solid-state TACAN ground transponder beacon with monitor; (d) Maintained and utilized an airborne interrogator-responder (AN/ARN-21) to assist in the testing of the solid-state transponder breadboards; and (e) Performed tests to compare the parameters of the solid-state transponder with the AN/URN-3 test bed (which the Montek team set-up and maintained while at Fort Dawes, Massachusetts).  (Continued on attached Sheet)		

14 KEY WORDS	LINK A		LINK B		LINK C	
	ROLE	WT	ROLE	WT	ROLE	WT
Communication Systems						
Navigational Aids (TACAN)						
Solid-State						
Design						
Tests						
Analysis						
Performance						
Statistics						
Data						
Ground - Air Transportable						

INSTRUCTIONS

1. **ORIGINATING ACTIVITY.** Enter the name and address of the contractor, subcontractor, grantee, Department of Defense activity or other organization (*corporate author*) issuing the report.
- 2a. **REPORT SECURITY CLASSIFICATION:** Enter the overall security classification of the report. Indicate whether "Restricted Data" is included. Marking is to be in accordance with appropriate security regulations.
- 2b. **GROUP:** Automatic downgrading is specified in DoD Directive 5200.10 and Armed Forces Industrial Manual. Enter the group number. Also, when applicable, show that optional markings have been used for Group 3 and Group 4 as authorized.
3. **REPORT TITLE:** Enter the complete report title in all capital letters. Titles in all cases should be unclassified. If a meaningful title cannot be selected without classification, show title classification in all capitals in parenthesis immediately following the title.
4. **DESCRIPTIVE NOTES:** If appropriate, enter the type of report, e.g., interim, progress, summary, annual, or final. Give the inclusive dates when a specific reporting period is covered.
5. **AUTHOR(S):** Enter the name(s) of author(s) as shown on or in the report. Enter last name, first name, middle initial. If military, show rank and branch of service. The name of the principal author is an absolute minimum requirement.
6. **REPORT DATE:** Enter the date of the report as day, month, year, or month, year. If more than one date appears on the report, use date of publication.
- 7a. **TOTAL NUMBER OF PAGES:** The total page count should follow normal pagination procedures, i.e., enter the number of pages containing information.
- 7b. **NUMBER OF REFERENCES:** Enter the total number of references cited in the report.
- 8a. **CONTRACT OR GRANT NUMBER:** If appropriate, enter the applicable number of the contract or grant under which the report was written.
- 8b, 8c, & 8d. **PROJECT NUMBER:** Enter the appropriate military department identification, such as project number, subproject number, system numbers, task number, etc.
- 9a. **ORIGINATOR'S REPORT NUMBER(S):** Enter the official report number by which the document will be identified and controlled by the originating activity. This number must be unique to this report.
- 9b. **OTHER REPORT NUMBER(S):** If the report has been assigned any other report numbers (*either by the originator or by the sponsor*), also enter this number(s).
10. **AVAILABILITY/LIMITATION NOTICES:** Enter any limitations on further dissemination of the report, other than those

imposed by security classification, using standard statements such as:

- (1) "Qualified requesters may obtain copies of this report from DDC."
- (2) "Foreign announcement and dissemination of this report by DDC is not authorized."
- (3) "U. S. Government agencies may obtain copies of this report directly from DDC. Other qualified DDC users shall request through \_\_\_\_\_."
- (4) "U. S. military agencies may obtain copies of this report directly from DDC. Other qualified users shall request through \_\_\_\_\_."
- (5) "All distribution of this report is controlled. Qualified DDC users shall request through \_\_\_\_\_."

If the report has been furnished to the Office of Technical Services, Department of Commerce, for sale to the public, indicate this fact and enter the price, if known.

11. **SUPPLEMENTARY NOTES:** Use for additional explanatory notes.
12. **SPONSORING MILITARY ACTIVITY:** Enter the name of the departmental project office or laboratory sponsoring (*paying for*) the research and development. Include address.
13. **ABSTRACT:** Enter an abstract giving a brief and factual summary of the document indicative of the report, even though it may also appear elsewhere in the body of the technical report. If additional space is required, a continuation sheet shall be attached.

It is highly desirable that the abstract of classified reports be unclassified. Each paragraph of the abstract shall end with an indication of the military security classification of the information in the paragraph, represented as (TS), (S), (C), or (U).

There is no limitation on the length of the abstract. However, the suggested length is from 150 to 225 words.

14. **KEY WORDS:** Key words are technically meaningful terms or short phrases that characterize a report and may be used as index entries for cataloging the report. Key words must be selected so that no security classification is required. Identifiers, such as equipment model designation, trade name, military project code name, geographic location, may be used as key words but will be followed by an indication of technical context. The assignment of links, rules, and weights is optional.

13. Abstract (Continued from DD Form 1473)

The USAF, under the conditions of the contract, was to provide the Montek team with an AN/TRN-17 set; however, since an AN/TRN-17 was unavailable, the team improvised (using AN URN-3 components) to overcome the resultant deficiencies.

Upon completion of the integration and testing of the solid-state major components, the team, with the aid of Montek's Navigational Aids Department, prepared a characteristic for each of the four major solid-state TACAN components and for a solid-state integrated test equipment package (see Appendix I).

It is recommended that the TACAN test bed maintained by the Montek team be installed and utilized as an experimental test bed at a site (selected by the USAF) which would be desirable for the testing of all TACAN parameters, including antenna flight test work.

Due to the basic deficiencies in the solid-state major components (breadboards) integrated and tested by the team under this contract, it is recommended that this solid-state test bed remain with the experimental facility and be used for experimental purposes only. Montek does not recommend that the USAF attempt to operationally utilize this particular solid-state transponder and monitor (breadboards).

This report and the characteristic contained herein are based on solid-state TACAN system analysis work, solid-state TACAN test results, solid-state TACAN integration work, and extensive experience in the TACAN field. It is recommended that the USAF initiate, at an early date, the continuance of the characteristic phase (Appendix I) of contract number AF 19(628)-3263 in a manner suggested in a letter proposal by Montek's Navigational Aids Department, Salt Lake City, Utah, entitled "State-of-the-Art Solid-State TACAN Equipment Characteristics," dated 4 September 1964.



DISTRIBUTION LIST, TECHNICAL DOCUMENTARY REPORT

<u>ACTIVITY</u>	<u>No. OF COPIES</u>
Hq ESD (ESRRG), L G Hanscom Field, Bedford, Mass.	8
Hq ESD (ESTI), L G Hanscom Field, Bedford, Mass.	22*
Hq ESD (ESRR), L G Hanscom Field, Bedford, Mass.	1
Hq TAC (DCE), Langley AFB Va.	1
TACSO/Major Dow, L G Hanscom Field, Bedford, Mass.	1
Hq AFSC (SCSEW), Andrews AFB, Wash 25 DC	2
Hq TAC (DORQ), Langley AFB Va.	2
Hq USAF (AFORQ), Washington 25 DC	1
Hq TAC (DOC), Langley AFB Va.	2
Hq ESD (ESRHA), Mr. Bagley, L G Hanscom Fld, Bedford, Mass.	1
ATTSC/Major Worthington, L G Hanscom Fld, Bedford, Mass.	1
AFLC (MCFC/Mr Deering), L G Hanscom Fld, Bedford, Mass.	1
Hq AFCS (CSXPRT), Scott AFB Ill	2
USARDL (SIGRA) SI-ADT/Tech Doc Center), Ft Monmouth, NJ	1
AFCL (CRMCLR), OAR, L G Hanscom Field, Bedford, Mass.	3
Hq ESD (ESST), L G Hanscom Field, Bedford, Mass.	1
Dept of Navy, NATC (NANEP Sr Officer), Patuxent River, Md	1
Hq AFCS (FFRE), Scott AFB Ill	2
AUL, The Air University, Maxwell AFB, Alabama	1
RADC (RAYLD/Doc Library), Griffiss AFB, NY	1
ASD (ASAPRD, Dist), Wright-Patterson AFB, Ohio	2
USA Elec Proving Ground (Tech Library), Ft Huachuca, Arizona	2
Hq USAF (AFOOP), Washington 25 DC	1

TOTAL COPIES: 60

\*ESD (ESTI) will accomplish distribution of report to DDC.