

ESD RECORD COPY

D-TDR-64-620

RETURN TO
SCIENTIFIC & TECHNICAL INFORMATION DIVISION
(ESTI), BUILDING 1211

39

COPY NR. _____ OF _____ COPIES

HUMAN USE OF SHORT TERM MEMORY IN PROCESSING
INFORMATION ON A CONSOLE

TECHNICAL DOCUMENTARY REPORT NO. ESD-TDR-64-620

SEPTEMBER 1964

Bernard P. Zeigler
Thomas B. Sheridan

ESTI PROCESSED

DDC TAB PROJ OFFICER

ACCESSION MASTER FILE

DATE _____

ESTI CONTROL NR. **AL 44315**

CY NR. 1 OF 1 CYB

DECISION SCIENCES LABORATORY
ELECTRONIC SYSTEMS DIVISION
AIR FORCE SYSTEMS COMMAND
UNITED STATES AIR FORCE
L. G. Hanscom Field, Bedford, Massachusetts

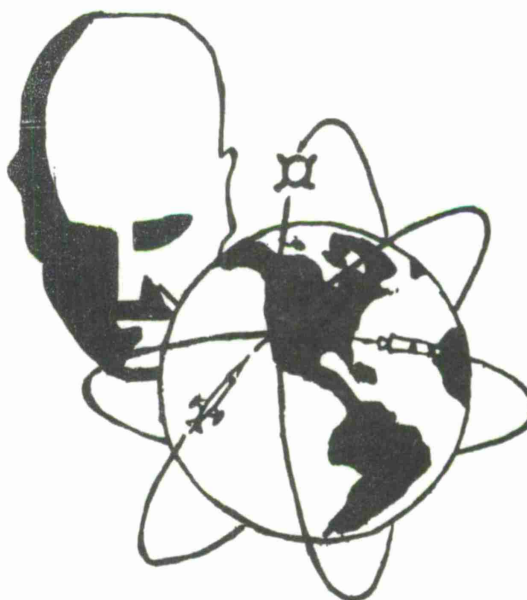

Project 7682, Task 768204

(Prepared under Contract No. AF 19 (628)-3317 by the Engineering Projects Laboratory,
Department of Mechanical Engineering, Massachusetts Institute of Technology.)

ADO 609749

ESTI FILE COPY

When US Government drawings, specifications or other data are used for any purpose other than a definitely related government procurement operation, the government thereby incurs no responsibility nor any obligation whatsoever; and the fact that the government may have formulated, furnished, or in any way supplied the said drawings, specifications, or other data is not to be regarded by implication or otherwise as in any manner licensing the holder or any other person or conveying any rights or permission to manufacture, use, or sell any patented invention that may in any way be related thereto.

Do not return this copy. Retain or destroy.

DDC AVAILABILITY NOTICES

Qualified requesters may obtain copies from Defense Documentation Center (DDC). Orders will be expedited if placed through the librarian or other person designated to request documents from DDC.

Copies available at Office of Technical Services, Department of Commerce.

ESD TDR -64-620

HUMAN USE OF SHORT TERM MEMORY IN PROCESSING
INFORMATION ON A CONSOLE

SEPTEMBER 1964

Bernard P. Zeigler

and

Thomas B. Sheridan

DECISION SCIENCES LABORATORY
ELECTRONIC SYSTEMS DIVISION
AIR FORCE SYSTEMS COMMAND
UNITED STATES AIR FORCE
L. G. Hanscom Field, Bedford, Massachusetts

(Prepared under Contract AF 19(628)-3317 by the Engineering Projects
Laboratory of the Department of Mechanical Engineering, Massachusetts
Institute of Technology)

This study was conducted in support of the applied research program of Decision Sciences Laboratory, under Task 768204, Automated Training of Information Systems, of Project 7682, Man-Computer Information Processing. One of the goals of this Task is the formulation of principles for design of automated training subsystems which could be built into future Information Systems. This study explores some effects of console design and information sequence on short-term memory during information processing.

The principal investigator was Dr. Thomas B. Sheridan. Authors were Mr. Bernard P. Zeigler and Dr. Thomas B. Sheridan. Air Force Task Scientist and contract monitor was Dr. Sylvia R. Mayer.

This report is similar to a thesis submitted by Mr. Bernard P. Zeigler to the Massachusetts Institute of Technology, Department of Electrical Engineering on May 22, 1964, in partial fulfillment of the requirements for Degree of Master of Science.

ABSTRACT

This report assumes that an operator's console constitutes a third form of memory in addition to that integral to the human and that integral to the machine which is not directly accessible to the human. Questions are raised concerning the characteristic modes of human storage and retrieval of information from internal memory when such external memory is accessible.

The report also introduces the concept of associative memory nets formed by cue-related images of external events. Information loss occurs when cues, originally capable of providing access to images, become insufficient to direct retrieval, in subsequent memory growth.

A list processing experiment is described. The processing involves adding or removing sequentially presented "items" (alphanumeric characters) from a list of previously processed items. Two conditions are established in which items are 1) presented directly, or 2) computed from presented data.

Storage structures characterizing internal human memory and external console memory in this task are postulated. A retrieval model implied by these structures is constructed to account for the effects of computation and learning upon the features of the experimentally obtained curves. Insufficient retrieval of required information from internal memory is assumed to necessitate external memory search. The effect of computation is to increase the probability of insufficient retrieval and hence the frequency of external search. Learning decreases this probability. The effects of inducing alternate forms of internal storage are studied and found generally to result in increased storage and retrieval times. Implications for console design are discussed.

REVIEW AND APPROVAL

This technical report has been reviewed and is approved.



JOSEPH T. BEGLEY
Chief, Applications Division
Decision Sciences Laboratory

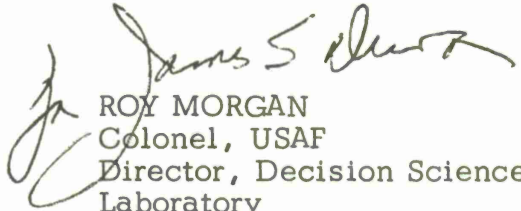

ROY MORGAN
Colonel, USAF
Director, Decision Sciences
Laboratory

TABLE OF CONTENTS

ABSTRACT	i
TABLE OF CONTENTS	ii
LIST OF FIGURES	iii
1. INTRODUCTION	1
2. EXPERIMENTAL METHOD	3
2.1 Console Apparatus	3
2.2 The List Processing Task	3
2.3 Design of Experiments	7
3. RESULTS OF EXPERIMENTS A AND B	14
4. SOME TENTATIVE MODELS FOR HUMAN USE OF CONSOLE MEMORY	20
4.1 Principle and Assumptions Upon Which to Base Our Models	20
4.2 Location Storage Model	22
4.3 Item Storage Model	24
4.4 Retrieval Model	24
5. RESULTS OF EXPERIMENTS C AND D, AND A RELEVANT MODEL	29
5.1 Location-Item Chunk Storage	29
5.2 Results of Experiments C and D. Effect of Replacing or Supplementing Item Storage	29
6. CONCLUSIONS	37
7. REFERENCES	38

LIST OF FIGURES

1	The Console Apparatus	4
2	a. Illuminated SC Program Sheet	5
	b. Appearance After Third Item	5
	c. Appearance After Fourth Item	
3	Basic Routine and Definition of Intervals Within Cycle	8
4	State Transition Diagram	12
5	a. Results of Experiments A (Combined Memory) and B (Dependence on Console Memory), Trial 1, Subject MR	15
	b. Results of Experiments A (Combined Memory) and B (Dependence on Console Memory), Trial 2, Subject MR	16
	c. Results of Experiments A (Combined Memory) and B (Dependence on Console Memory), Trial 1, Subject RF	17
	d. Results of Experiments A (Combined Memory) and B (Dependence on Console Memory), Trial 2, Subject RF	18
6	Cue Association in Associative Memory	21
7	Storage Structures (arrows indicate access direction)	23
8	Retrieval Model	26
9	List Processing Times Predicted by Retrieval Model	28
10	a. Effects of Forced and Free Update Procedures, Subject MR	30
	b. Effects of Forced and Free Update Procedures, Subject RF	31
11	a. Effects of Update Procedures, Subject MR	32
	b. Effects of Update Procedures, Subject RF	33
12	a. Effects of Forced Updating, Subject MR	34
	b. Effects of Forced Updating, Subject RF	35

1. INTRODUCTION

Rapid developments are being made in the realization of computer systems which are accessible and convenient aids to human intellectual processes. Man-machine co-operation in problem solving places emphasis on the design of console devices for the efficient communication of information between man and machine. If computer-aided thinking is indeed to be realized, the form and content of information conveyed by the computer console must be such as to truly facilitate the human thought processes.

While dimensions of the problem are many, one discernable function of the console is as an external memory system, i. e. , external to the human. The display and manipulatory devices belonging to the console serve not only to transmit human decisions to the computer and vice versa but also, to varying degrees, to record or establish memory of this action and its consequences. We shall think of this external or console memory system as capable of being addressed and decoded by a human processor to retrieve the results of previous processing events. Paper and pencil is the most obvious and common of such systems. So are the devices -- plugs, knobs, switches, light pens, through which man-machine communication is effected and which will perhaps supplant paper and pencil as the immediate agents of human decision.

We shall distinguish, then, between external and internal memory systems, the former referring to the configuration of the console both directly visually accessible or accessible by simple actuation of switches, and the latter referring to human memory. Such a distinction raises questions regarding the storage and retrieval of information in these systems and the interaction of one upon the other. Note that we de-emphasize the role of the conventional computer memory per se. From the human's point of view and depending upon the task this memory is not directly manifest and interacts with the human only as it augments console memory.

With regard to storage one must begin by accepting that very little is known regarding human memory mechanisms but what is known is not generally cast in a language compatible with that of the computer designer. But can we identify the characteristic modes for internal

storage of the results of man-machine operations? How do these depend on the nature of the processing task and the console on which it is performed? How do modes of storage in internal memory differ from those of external memory?

With regard to retrieval we can compare the modes of retrieval from internal and external memory as dependent upon the storage structures employed. We may ask questions concerning the efficiency of retrieval and the relative time requirements of retrieving the same information from different systems.

Finally we may ask questions regarding the relative use of external and internal memory by the human processor. How does this use depend on the nature of the task and the console on which it is performed? Are the apparent modes of memory storage adopted by subjects optimal in some sense? What is the effect of attempts to impose on the human alternate memory strategies?

The present experiment was an attempt to generate a method whereby human use of internal and external memory may be measured and analyzed. We tried to answer the questions raised above for a particular information processing task performed on a particular console. The task being arbitrary, the particular quantitative results obtained are less important than the assumptions made and the methods developed.

2. EXPERIMENTAL METHOD

The experimental task required the human subject to continually modify a list of alphanumeric characters or "items" according to the nature of other continually presented data. The framework is similar to that used in recently developed experiments involving recognition and recall (1, 2, 3), with these exceptions: Emphasis here is placed on the effect of the console on the memory task; time is used rather than errors as the measured variable; and behavior is described from an information processing standpoint.

2. 1. Console Apparatus

The console apparatus used throughout the experiment is illustrated in Fig. 1. It consists of a chassis whose top surface (8-1/2 in. x 11-1/2 in.) is sectioned into 2 rows of 7 compartments. Data are presented in the upper row of data compartments. Depression of one of the seven (pushbutton) switches at the front surface of the chassis illuminates the corresponding data compartment. Similarly, the seven toggle or list switches on the top surface illuminate the adjacent list compartments (lower row). Finally, a toggle switch at the left side called the update switch, can be used as a master control of power to the list compartments.

The console is made operational by securing a suitably prepared program sheet over the sectioned area. An example of a completely illuminated program sheet is shown in Fig. 2a. The location marker numbers 1 through 7 are visible only when illuminated by manipulation of corresponding list compartment switches. Thus for example, list switches 1, 2, and 3 have been turned on in Fig. 2b. In operation, a subject is prevented from viewing the list when data are presented, i. e., depression of a data switch interrupts power to the list compartments.

2. 2. The List Processing Task

The experimental task consisted of sequentially viewing a pair of data characters (numbers) in an illuminated compartment, deriving from these a "computed item" (letter character) and activating switches to add or remove this item from a list of such previously derived items.

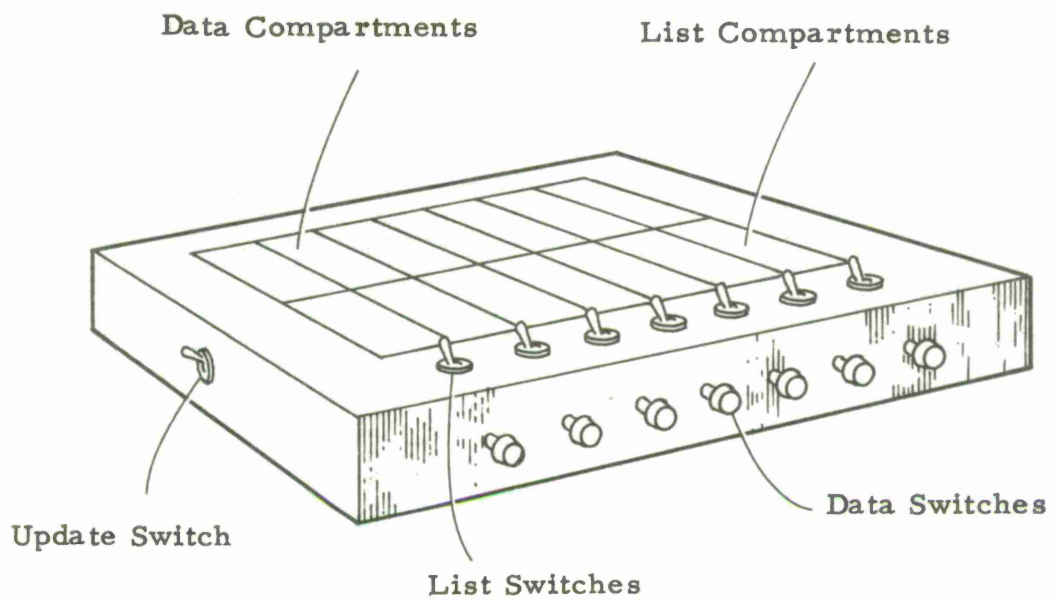

Fig. 1. The Console Apparatus.

5	6	8	7	3	7	6	← Data
6	9	2	5	8	8	6	
1	2	3	4	5	6	7	← Location Markers
Z	Y	X	Y	Y	X	X	← List of Items

Fig. 2a. Illuminated SC Program Sheet.

1	2	3	4	5	6	7
Z	Y	X				

Fig. 2b. Appearance After Third Item.

1	2	3	4	5	6	7
Z		X				

Fig. 2c. Appearance After Fourth Item.

Fig. 2.

Program sheets were of two types: NC, or "no computation required," and SC or "some computation required" to arrive at the computed items. Referring to the example of an SC program sheet shown in Fig. 2a, the numbers contained in the data compartments were sufficient to compute the item appearing directly below in the list compartment. An NC program was simpler in that the same item appears in the corresponding data and list compartments.

Data and list switches were handled by the right hand, the left being used to manipulate the update switch where required.

An outline of the processing procedure explained to subjects is as follows:

"Starting with the first set of data and list characters on the left, repeat the following cycle, processing the items sequentially until items in all seven sets of compartments have been processed.

- 1) Depress the data switch, compute the appropriate list item and release the switch.
- 2) If the computed item is not already on the list put it on the list by setting to "on" the list switch on the compartment directly below.
- 3) If the computed item is already on the list, take it off the list by setting to "off" the list switch of the compartment containing the item.

To compute an item in the SC case, multiply the two given numbers and classify the units digit of the result as either "X", "Y", or "Z" according to the scheme: 8, 7, or 6 is X; 5, 4, or 3 is Y; 2, 1, or 0 is Z. In the NC case, of course, all that is necessary is to look at the item, but in both cases make sure that you have the item firmly in mind before releasing the item switch.

Give your undivided attention to each operation as you do it, without worrying about what has happened or is about to happen."

As an example of the processing consider the appearance of the program of Fig. 2a after the third item has been processed. Since each of the first three items is new, the list will be that shown in Fig. 2b.

The fourth item however, is a "Y", and since it is already on the list, removing it results in the list illustrated in Fig. 2c. Thus the processing required involves seven repetitions of a basic routine. Each repetition is referred to as a cycle. As illustrated in Fig. 3, time intervals involved in the operation in each cycle of the routine were defined as follows:

- a) t_i -- item processing time, the time to compute an item from input data;
- b) t_l -- list processing time, the time to effect a list modification, i. e., to put on or take off an item from the list; further categorized into
 - 1) t_{l+} -- put-on time, the time required to add an item to a list. This is the time required to effect the transitions $0 \rightarrow 1$, $1 \rightarrow 2$, and $2 \rightarrow 3$, where numbers specify the state of the list, i. e., the number of items on it.
 - 2) t_{l-} -- take-off time, the time required to remove an item from a list. This is the time required to effect transitions, $1 \rightarrow 0$, $2 \rightarrow 1$ and $3 \rightarrow 2$.
- c) t_u -- update time, the time to establish memory of a modified list (explained in context below).

2.3. Design of Experiments

Four separate experiments were run (designated A, B, C, D).

Experiment A. Combined Human and Console Memory measured performance under the basic processing procedure outlined above. A test trail consisted of running 20 program sheets of either the NC or SC type.

Experiment B. Use of Human Memory Constrained was designated to obtain limiting values for list processing times when all possibility for human internal short term memory usage is removed. A trial consisted of a running of either the NC or SC program sets, each sheet yielding one measurement of list processing time. The procedure for each sheet was as follows:

With the subject's attention diverted elsewhere and with the update switch off, a list was created by the setting of appropriate list switches. The subject was then told which data switch contained one

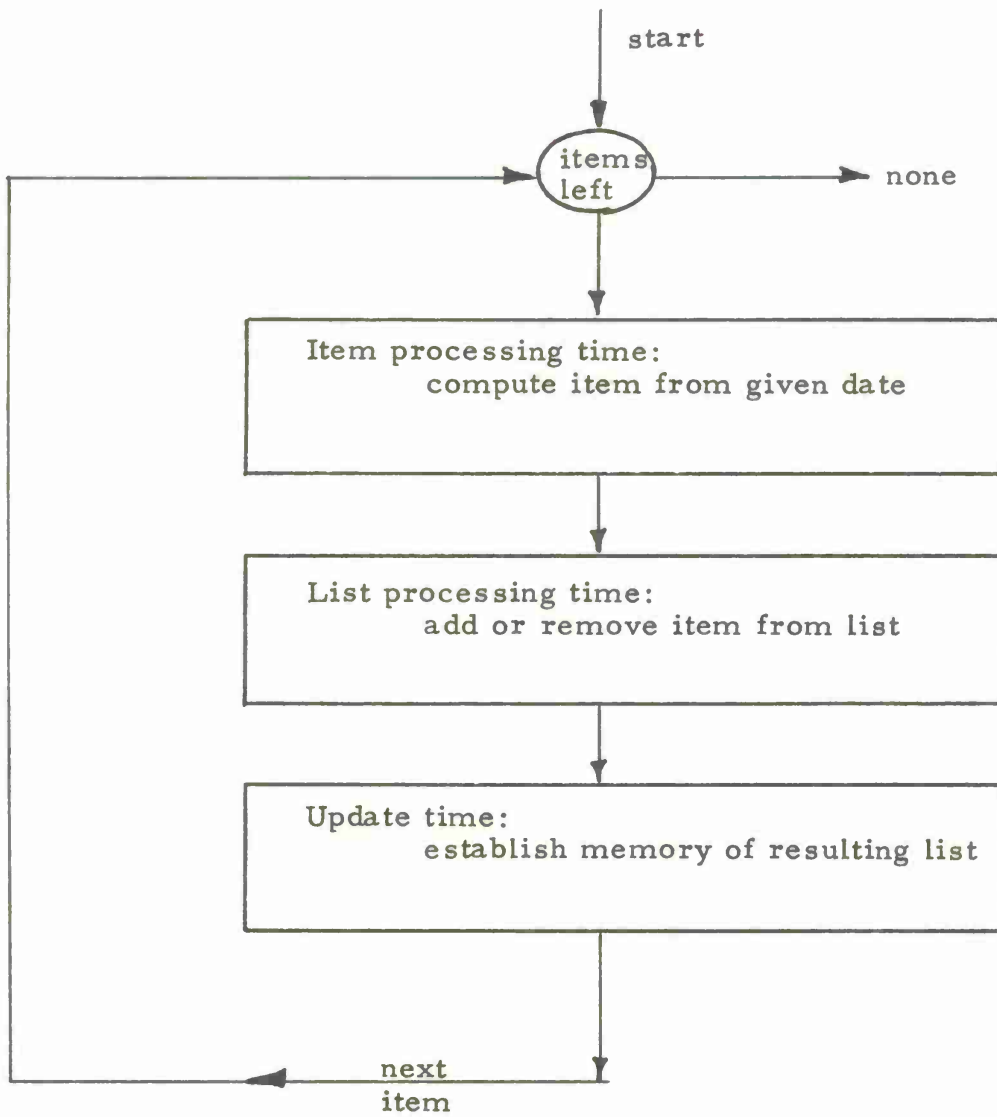

Fig. 3. Basic Routine and Definition of Intervals Within Cycle.

of the items on the list. The subject's task was, first, to compute the item. Then he was to depress the update switch, scan the list, and remove the item from the list by setting to "off" the corresponding list switch. Lists were created so as to correspond to situations actually encountered in the processing task (Experiment A). In effect, the dynamic processing (which in Experiment A surely involved some short term memory) was interrupted and held, so that the list processing times involved in purely visual search could be measured.

Experiment C. Use of Console Memory Constrained, Forced Updating of Human Memory measured the effect of "forced updating" of memory on list processing performance. By forced updating we shall mean the following:

At the end of each cycle, after having processed the list, the subject was instructed to remember the items and their locations on the list according to item-location correspondence. For instance, the list of Fig. 2c was to be remembered as (1-Z, 3-X). To store this list, the subject was to say "One-zee, three-eks" while looking at the list. Furthermore, the subject was instructed to attempt list modification from the memory so established rather than resort to any other recall or to the console display. Visual access to the console was controlled by the update switch which was "on" only during the interval of forced updating. (which prevented viewing of the items, but left the position marker numbers plainly in view).

The procedure for each cycle was as follows:

- 1) Depress the data switch, compute the item, and release the switch.
- 2) Use the memory established by forced updating to attempt the appropriate item removal from, or addition to, the list.
- 3) Turn on the update switch, observe the new list and try to remember it by item-location correspondence and turn off the update switch.

A trial in Experiment C consisted of the running of 20 program sets of either the NC or SC type.

Experiment D. Combined Memory with Forced Updating was designed to observe the subject's performance under conditions of forced

updating while visual access to the console was always available. Thus the basic procedure differed from that of Experiment A in that the subject was instructed to update the list in the manner of Experiment C. Furthermore, he was instructed to use the memory so established for appropriate list modification even though the console is always visually accessible. The procedure for each cycle was as follows:

- 1) Depress data switch, compute item, and release the switch.
- 2) Attempt list modification from memory established by forced updating.
- 3) Update using the same item-location mnemonic as in Experiment C.

Only the 20 program NC set was run in Experiment D.

Operational definitions of time intervals involved in the various tests are presented in Table I.

Under the processing rules, lists of 0, 1, 2 or 3 items were possible.

The process governing the list state transitions is Markovian with the transition diagram shown in Fig. 4. In order to distribute the item appearances and the state transitions as equally as possible, 20 (7-cycle) sequences were programmed (identical for each of the NC and SC sets). In the first two cycles a list state two was always established (by having the second item differ from the first); the remaining five cycles involved a total of $5 \times 20 = 100$ transitions, the distribution of which is shown in Table I.

Two Massachusetts Institute of Technology undergraduate students served as experimental subjects. Subject RF was tested for a total of five hours, while MR was tested for four hours, over a period of one week. The extra hour given RF went toward initial practice. Each experimental session lasted one hour, and subjects were paid at a rate of \$1.25 per hour.

A typical session consisted of the running of two test trials. Each was preceded by a practice run of 10 programs, at the beginning of which the subject was instructed to find his fastest rate consistent with his ability to perform accurately. In the case of SC trials, preliminary

TABLE I - OPERATIONAL DEFINITIONS OF TIME INTERVALS

Experiment	t_i - <u>item</u> processing time	t_e - <u>list</u> processing time	t_u - <u>update</u> time
A	interval between depression and release of data switch	interval between release of a data switch and setting of a list switch	interval between setting of a list switch and depression of a data switch
B	_____	interval between setting "on" of the update switch and setting "off" of a list switch	_____
C	Same as A	interval between release of a data switch and setting to "on" of the update switch	interval between setting to "on" and setting to "off" of the update switch
D	Same as A	Same as A	Same as A

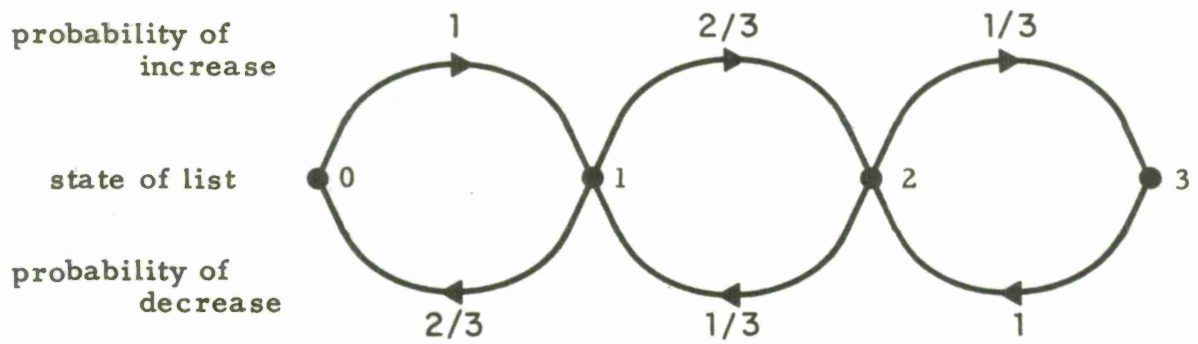

Fig. 4. State Transition Diagram.

practice was also given in computational procedure. Before starting a measured run the subject was told that errors incurred in the processing of any sheet would necessitate re-running of that sheet. Actually, errors occurred infrequently after initial practice.

3. RESULTS OF EXPERIMENTS A AND B

The use of internal and external memory under normal circumstances was measured in experiments designated A and B. One trial of test A involved measurement of item processing, list processing and update intervals required by subjects in following the basic procedure through the 20 programs comprising a NC or SC set.

The effect of having to compute an item against merely having to accept the item was determined by comparing performance in the NC and SC cases. In order to determine the effect of practice, two trials of Experiment A in the NC and SC conditions were run for each subject.

The list processing interval may be taken as the time required to retrieve information from either or both internal and external memory in order to activate an appropriate list modification. Fig. 5 presents list processing times plotted against the list state transition effected during the cycle. In these as in all graphs to be presented, points represent averages over 20 program sets (each point represents between 11 and 25 measurements as may be seen by reference to Table I). Curves drawn are for the first and second trials for subjects MR and RF in the NC and SC conditions. Also shown are measurements obtained in Experiment B, which measured list processing times under conditions of external memory use primarily. The latter measurements were of the time required to remove an item from a newly presented list of 1, 2 or 3 items.

Let us note several interesting features of these results. First, observe that the curves of the NC condition of Experiment A lie well below the Experiment B curve. That is, the use of internal or human memory results in a considerable time saving in effecting a list state transition compared to times required by external or console memory usage.

Second, the curves for the SC condition of Experiment A lie well above the NC curves. The effect of computation, then, is an overall increase in list processing time and, presumably, an impairment of internal memory use. As is apparent in the second trial curves, the effect of practice is to decrease the overall list processing times in the SC condition, and to a lesser extent in the NC condition.

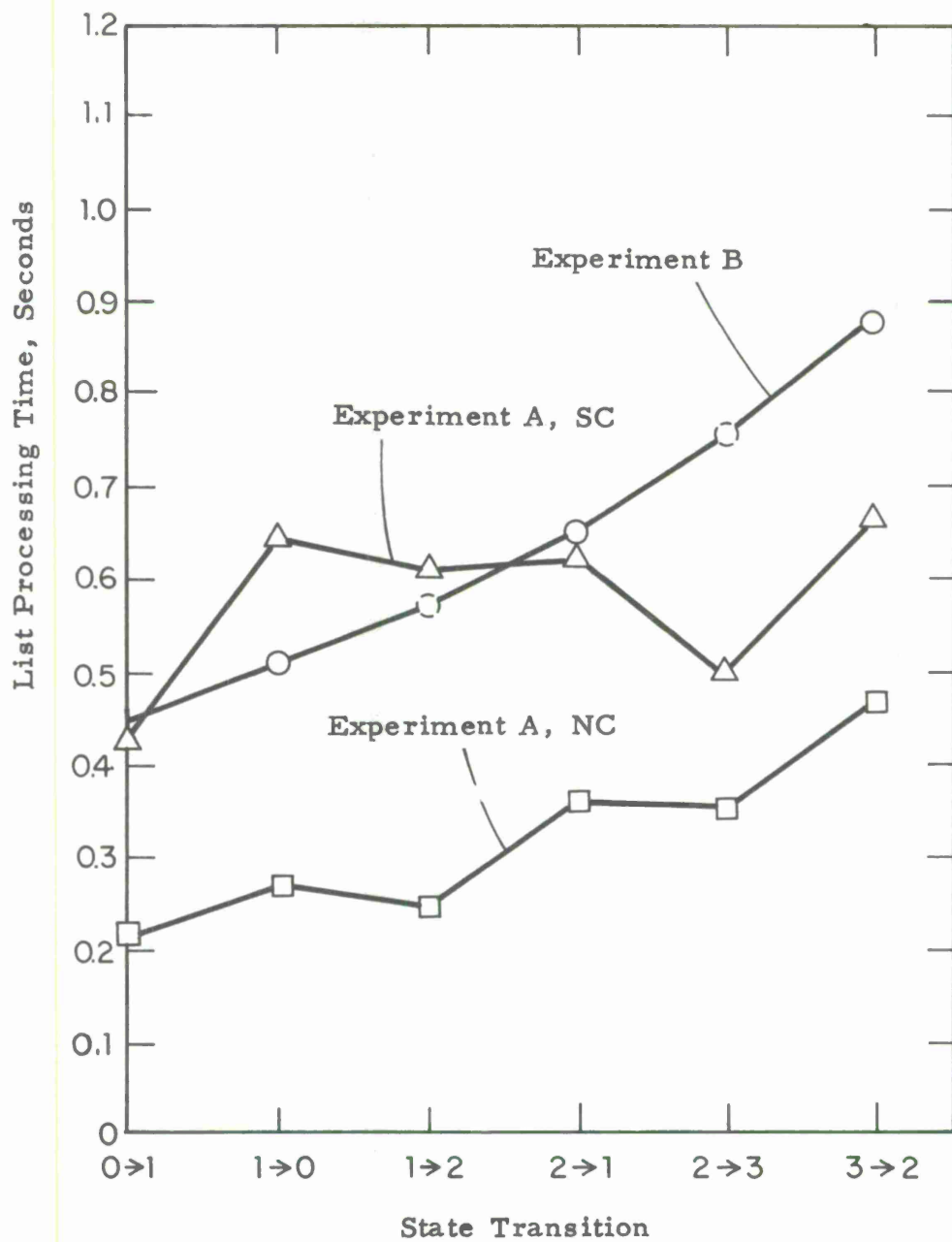

Fig. 5a. Results of Experiments A (Combined Memory) and B (Dependence on Console Memory), Trial 1, Subject MR.

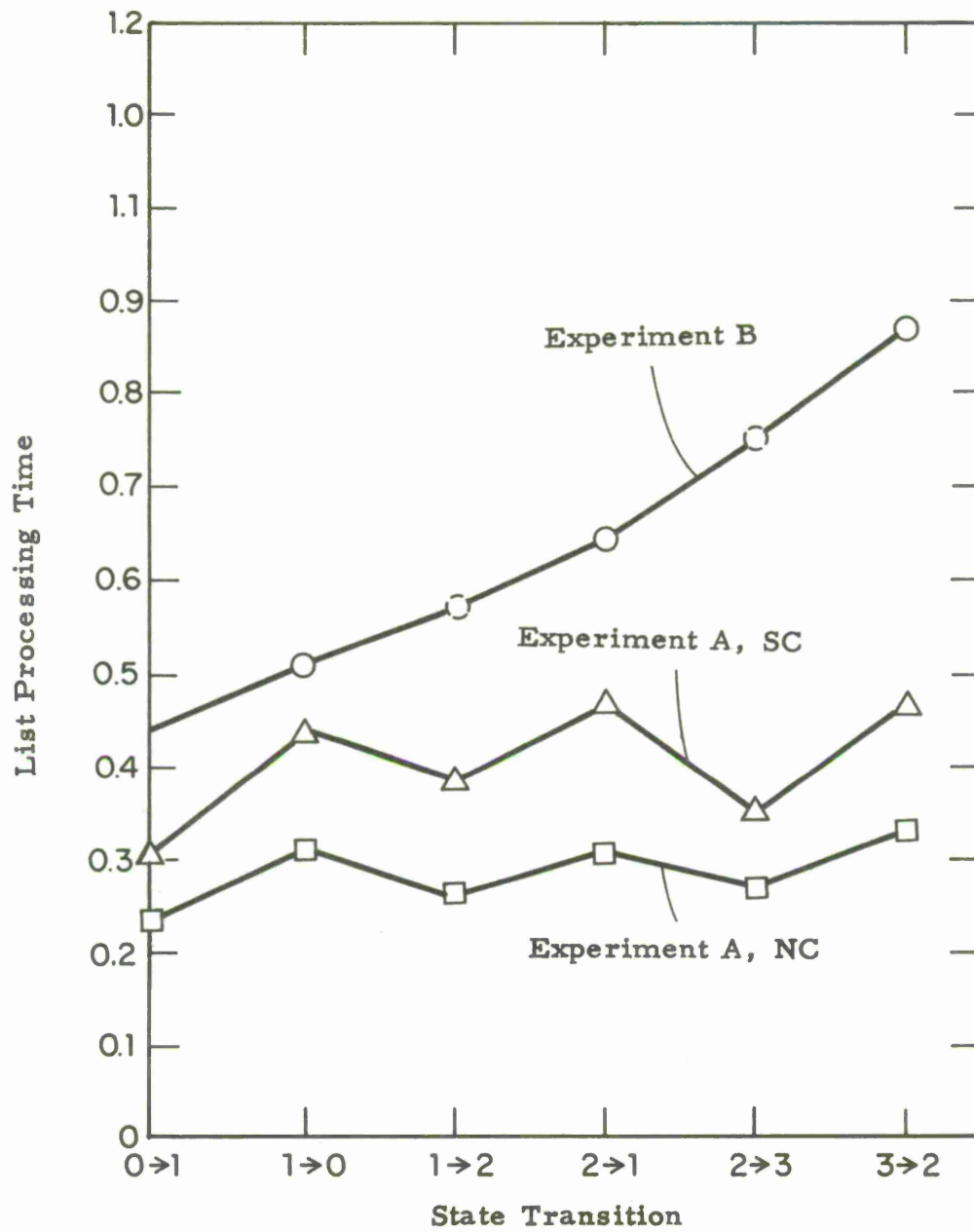

Fig. 5b. Results of Experiments A (Combined Memory) and B (Dependence on Console Memory), Trial 2, Subject MR.

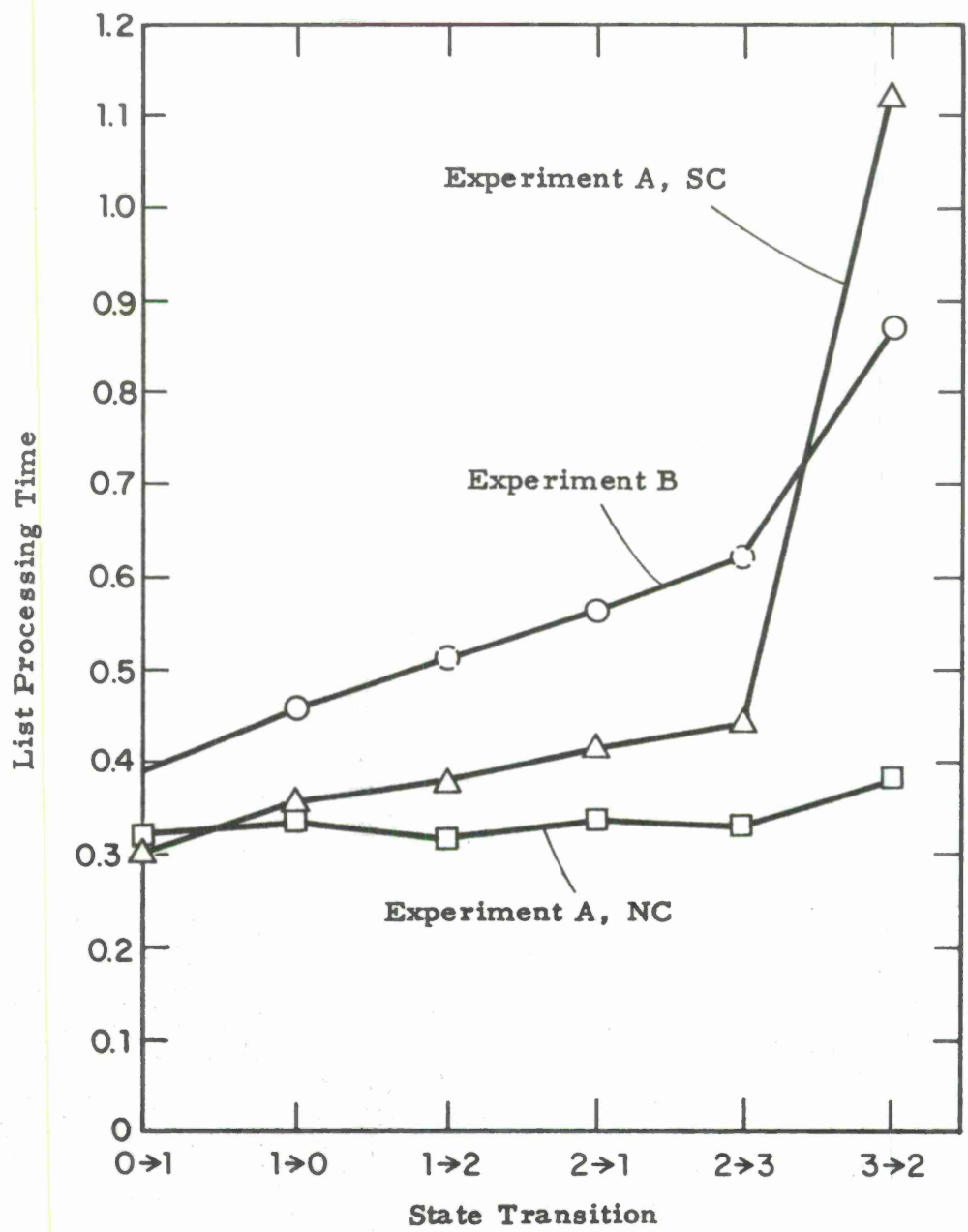

Fig. 5c. Results of Experiments A (Combined Memory) and B (Dependence on Console Memory), Trial 1, Subject RF.

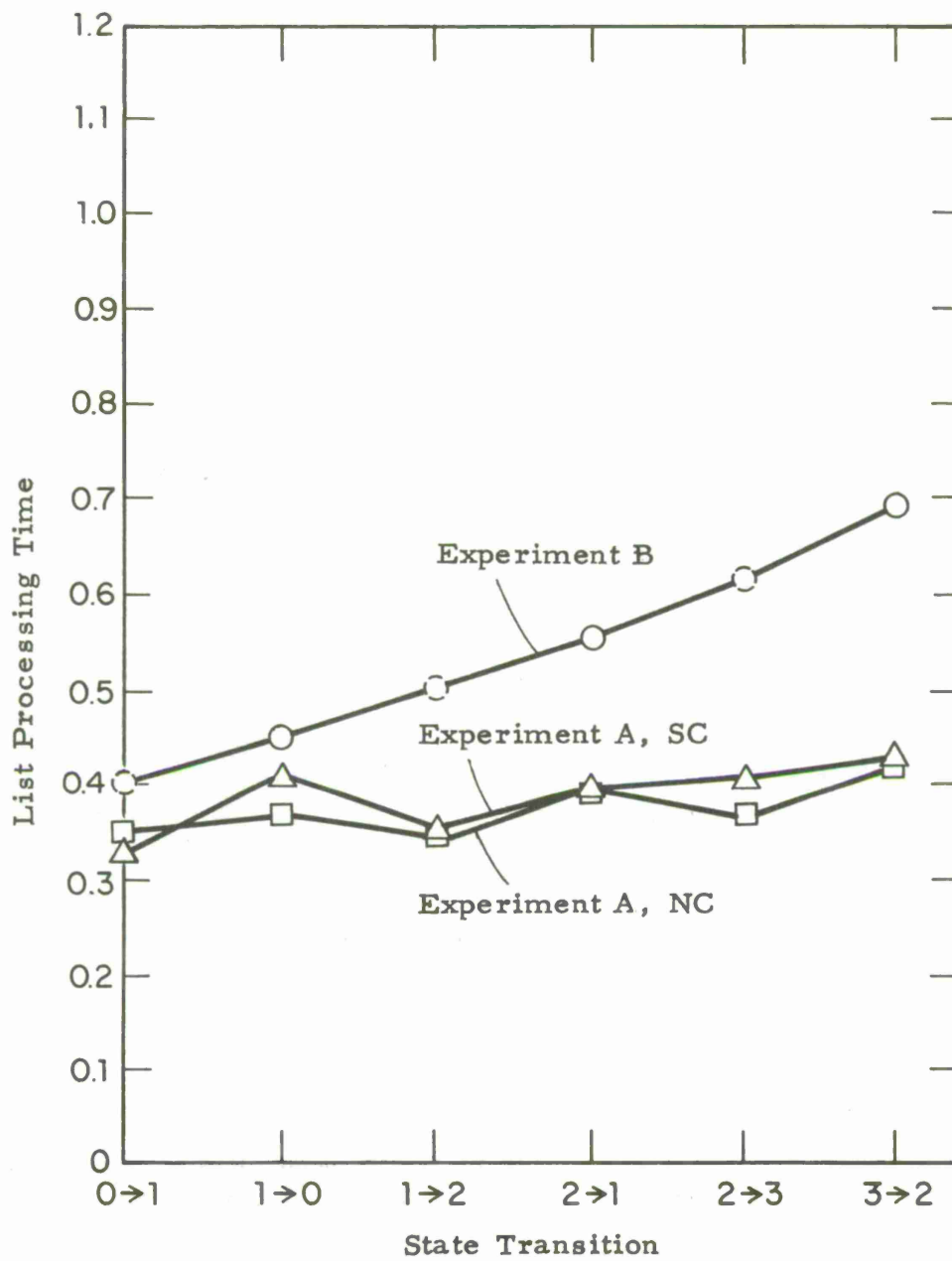

Fig. 5d. Results of Experiments A (Combined Memory) and B (Dependence on Console Memory), Trial 2, Subject RF.

Third, the take-off time generally exceeded the put-on times. The resulting zig-zag pattern of Experiment A curves is in contrast to the more uniform increase of the Experiment B curve.

Finally, the average slope of Experiment A curves are less than that of the Experiment B curve. Indeed, in some cases, as in the SC curves of trial 2, the take-off time for transition 1→0 exceeds the 3→2 take-off time.

We conclude tentatively that performance under conditions of free use of internal or human memory contrasts markedly to performance under use primarily of external or console memory.

The following sections attempt to account for the particular features of the experimental results in terms of storage and retrieval models of internal and external memory.

The results of experiments C and D will be covered in Section 5 of this report.

4. SOME TENTATIVE MODELS FOR HUMAN USE OF CONSOLE MEMORY

4.1. Principle and Assumptions Upon Which to Base Our Models

Cognitive models (4, 5) conceive of the human as a serial processor who breaks up information into a limited number of "chunks" (6) to be attended to one at a time. The temporary storage of chunks is referred to as immediate memory (7-13). The storage of information for later use is referred to as short or long term memory depending on time intervals between storage and retrieval. From an information processing standpoint, memory consists of processes for encoding events into symbols, storing the symbols, and subsequently retrieving and decoding the symbols into forms suitable for action.

Human memory is called "associative," i. e. , the storage of an event or the formation of its image depends upon the previously stored experience of the individual. Associated pairs of images are presumably formed by the storing of a cue with one image which may be used to retrieve the associate image. Graphically we can represent a cue as a pointer from one image to the other in an associate pair (Fig. 6). A cue provides access from one image to another and the degree of access is variable. The result of loss of access is insufficient retrieval or forgetting.

Feigenbaum's (5) EPAM (elementary processor and memorizer) model postulates definite processes for the 'dating' of cues resulting in unsuccessful retrieval of associated images. We shall make use of the concept of storage structures or nets of images interaccessible by means of cues subject to dating.

Particularly relevant to the present modelling, we shall also make use of the following self evident principle: the manner in which information is stored in a memory system determines the manner in which it must be retrieved.

We shall also make the following assumption regarding human memory storage; events are stored in human memory in associative structures determined by the order in which they were experienced or attended to. This implies that human memory is based upon a serial processing mechanism.

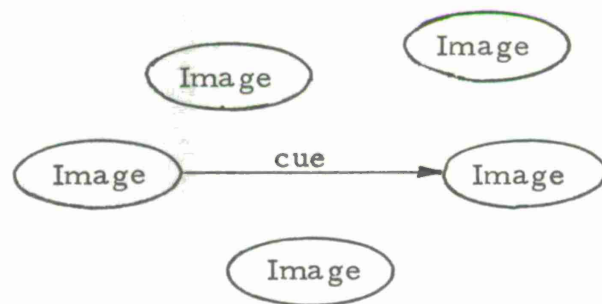

Fig. 6. Cue Association in Associative Memory.

Based on these ideas, we shall consider the storage and retrieval aspects of three types of information storage structures. These will be referred to as location storage, item storage and location-item chunk storage.

4.2. Location Storage Model

In discussing storage structures we shall use as illustration the processed list of Fig. 2. The appearance of the list after processing of the third item is shown in the upper left hand corner of Fig. 7 as ZYX. The next item is a "Y" and appropriate processing yields the list of the second column, Z-X.

Now, let us consider the structural representation of the external memory constituted by the console. Since items are placed in locations we shall refer to the structure as location storage. In Fig. 7, corresponding with "location storage," locations form the top level of the representation net. According to our principle, there is a retrieval process characteristic of this type of storage. To "remember" or determine whether a given item is presently on the list, the locations must be examined in some sequence and the item contained in each compared with the given item. The process continues until a match is found, or until all locations have been exhausted. Since the scanning sequence is arbitrary, we have not given direction arrows to the top level pointers. (However, observation suggested that both of our experimental subjects adopted a left to right search.)

Assuming that examination of each location requires a given amount of time, we expect that

- 1) the average take-off time will increase with the number of locations, i. e., the state of the list,
- 2) for a given initial state, put-on time exceeds take-off time, since put-on occurs only after all locations have been examined, whereas take-off may occur after examining only one or two locations.

Informal checks suggested that put-on times exceeded take-off times in Experiment B, where human memory was not dominant. A good estimation of put-on times was derived by averaging adjacent take-off points as shown by the broken circles on the Experiment B curve of Fig. 5. Thus, retrieval of information by humans from external memory would thus far appear consistent with "location storage."

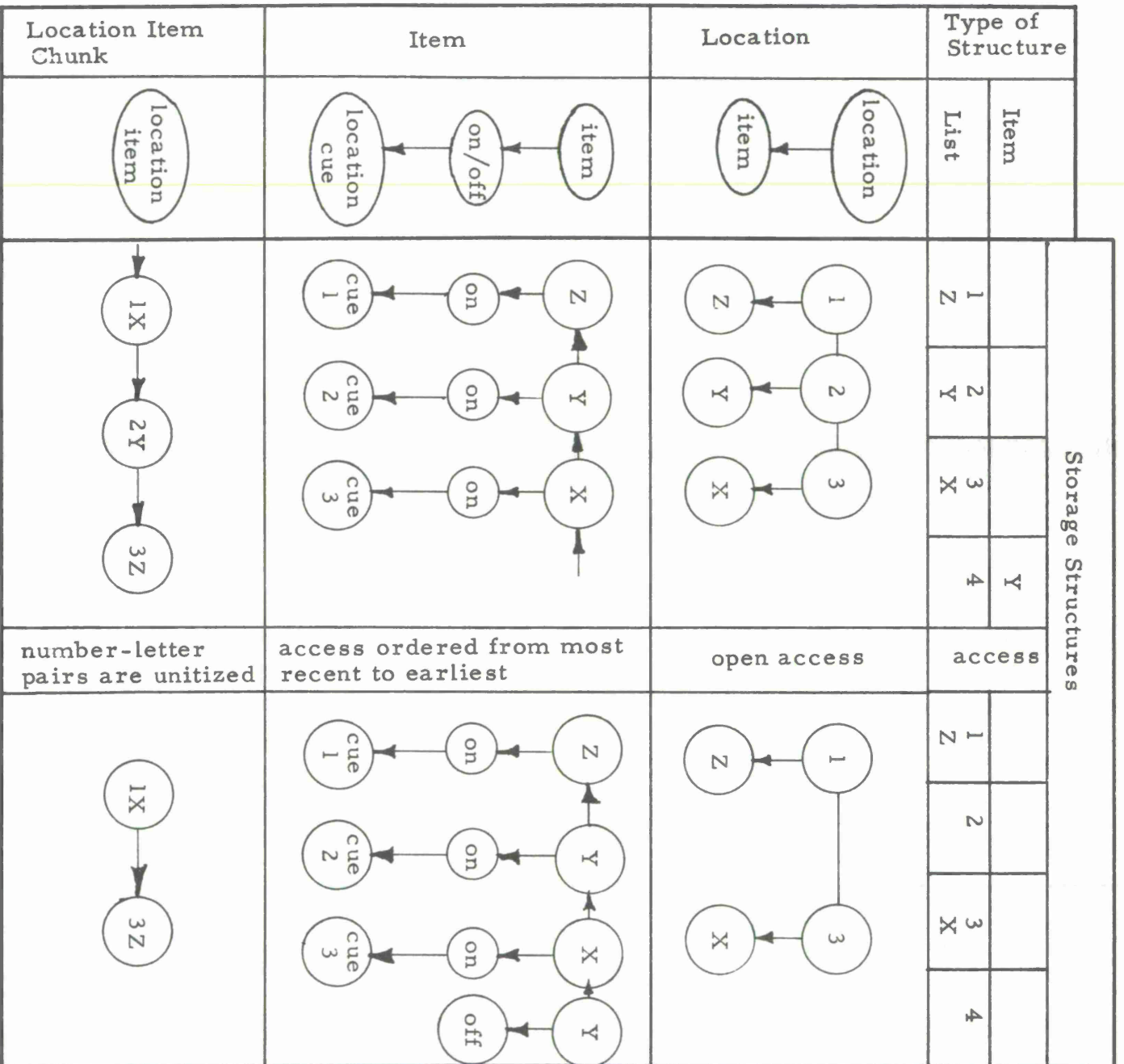

Fig. 7. Storage Structures (arrows indicate access direction).

4.3. Item Storage Model

The dissimilarity of Experiment A and Experiment B curves of Fig. 5 suggests that location storage is not characteristic of human internal memory.

Our aforesaid assumption states that items are stored in the order of attending required by the processing task. Consider that in each cycle, the subject

- 1) computes the item,
- 2) decides whether it is to be put on or taken off the list, and
- 3) performs the appropriate list switch manipulation.

Accordingly we postulate that the associative structure shown in Fig. 7 and referred to as "item storage" is set up by the processing order required in this task. Item images form the top level of the net, associated with an image indicating whether the item has been placed on or taken off the console. We further postulate that information for each cycle is stored in the order in which cycles were attended to. Thus, for example, after processing of the fourth item, the net of the left hand column of Fig. 7 will have grown to that of the right hand column. This is in contrast to the other structures discussed which represent only the present state of the list, and show no indication of the past history of processing.⁺

Location Item Chunk Storage, shown in Fig. 7 for later comparison, will be dealt with in Section 5.

4.4. Retrieval Model

Our operating principle stipulates a retrieval process characteristic of item storage. Accordingly, we postulate that first an attempt is made

⁺ The location cue may possibly be the location marker itself, although this would require the extra time of attending to the marker while setting the list switch. Under the instructions to perform as rapidly as possible, subjects were more likely to use cues based on the order of item occurrence, or to use other easily processed visual and manipulatory cues. Thus in the SC condition of trial 1 of Experiment A, subject RF evolved a strategy whereby his left hand remained at the location of the item after the right hand had set the switch. This substantially reduced the difference between put-on and take-off times. Since Experiment C required use of the left hand to set the update switch, RF was subsequently instructed to use only the right hand for manipulating both item and list switches, as was MR, so as to standardize strategy used in all tests.

to recognize the item internally by sorting its image through the discrimination structure represented by the top level of the net, moving in the direction of the arrows shown for item storage. If correct recognition takes place, the associated "on/off" image is found. If the image is "off," indicating the item not to be presently on the list, the appropriate manipulatory action is effected, placing the item on the list. Otherwise, an attempt is made to retrieve the location cue. If correct retrieval occurs, this cue is used to locate the item on the console and then to remove it from the list.

We have added to our retrieval model of Fig. 8, the effect of the "dating" of cues. Such dating reduces the certainty that images will actually be found in the subsequent growth of the net after their initial storage. We have allowed for this by assigning probabilities q_1 and q_2 that insufficient information exists for the recognition of items, and the retrieval of locations, respectively. Further, we postulate that in cases where such information cannot be retrieved, the processor must search the console before attempting appropriate manipulatory action. Thus, it is assumed that the human processor must retrieve from external memory the information which he cannot retrieve from internal memory.

In the model of Fig. 8, times have been assigned to the various processes as shown in the rectangular blocks. We assumed a 0.32 sec "reaction time" which obtains in every case.

We have assumed that retrieval from external memory takes longer than that from internal memory, and can be measured as in Experiment B. The factor of six times longer was taken arbitrarily to fit the data.

Further we assumed the times involved in both external and internal retrieval are linearly dependent on the list state, n , which follows directly from our location model, not so directly from our item storage model (hence justifying a smaller coefficient in the latter case). A constant 0.06 sec was arbitrarily added to the internal take-off time and the external put-on time; according to our model internal retrieval of on-items involves location cues, requiring more take-off processing time than internal off-items; external retrieval of off-items requires an exhaustive search of locations, requiring more put-on processing time than external on-items. The scale of time values was approximately adjusted to fit subject RF's performance.

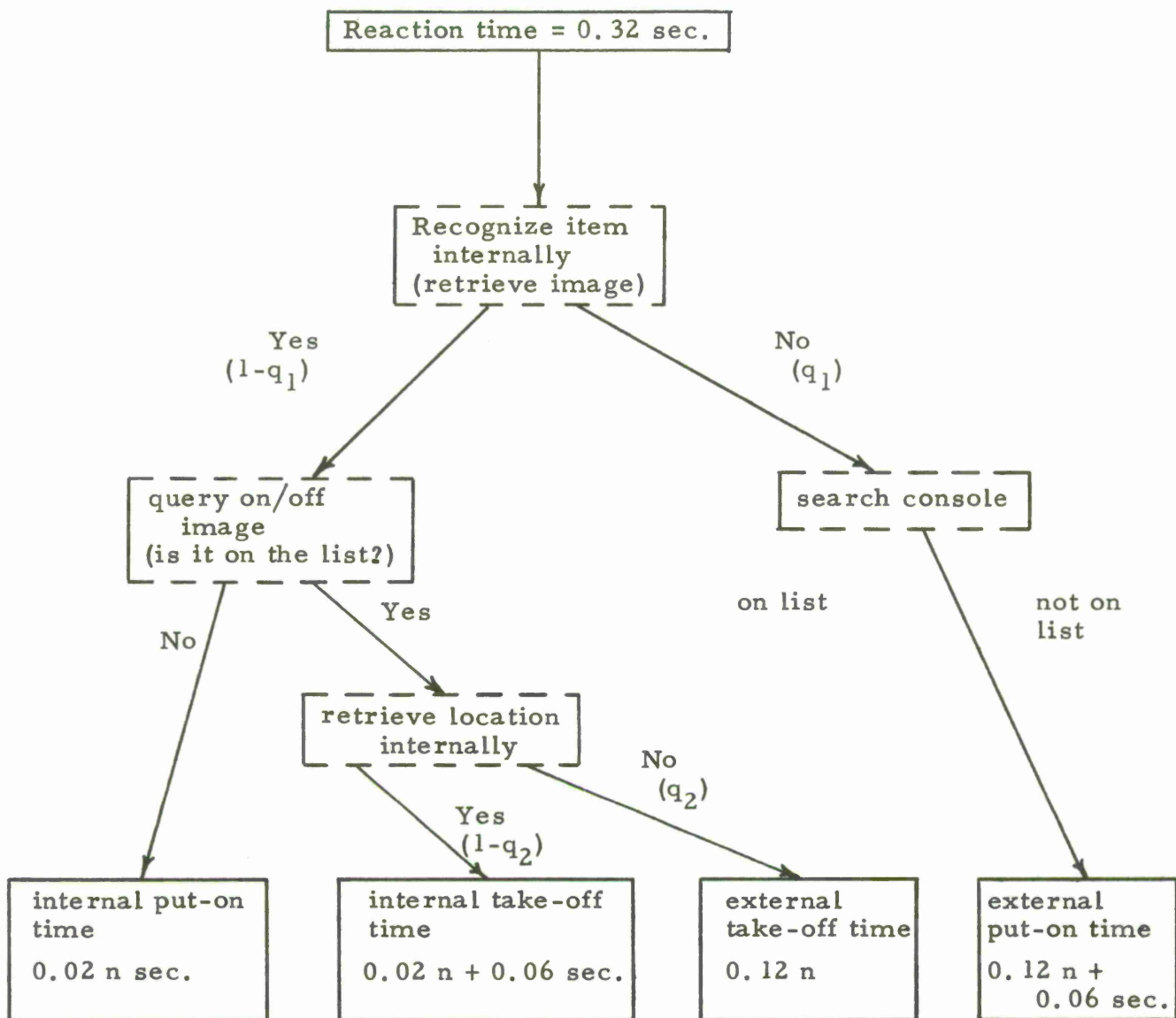

q_1 = probability of insufficient item retrieval from internal (human) memory.

q_2 = probability of insufficient location retrieval from internal (human) memory.

n = state of list (number of items on list).

$$\text{Expected put-on time} = 8 + (1 - q_1) n/2 + (q_1) (3n + 3/2).$$

$$\text{Expected take-off time} = 8 + (1 - q_1) \left[(1 - q_2) (n/2 + 3/2) + q_2 (3n) \right] + q_1 (3n).$$

(Times indicated in lower row of blocks include all processing subsequent to initial reaction time.)

Fig. 8. Retrieval Model.

Thus while certain properties of the quantitative expressions in Fig. 8 represent the simplest statements consistent with the memory and retrieval models, certain coefficients were arbitrarily chosen to provide a reasonable fit with the data.

By summing the appropriate values shown at the bottom of Fig. 8 we arrive at expected list processing times, with q_1 and q_2 as parameters and state transition as independent variable, (Fig. 9). The case $q_1 = q_2 = 1$ represents total reliance on external memory and corresponds to the measurements of Experiment B. The case $q_1 = q_2 = 0$ represents exclusive use of internal memory. We note the difference in overall level and slope of the curves for these two cases. The case $q_1 = q_2 = 1/4$ manifests a general rise in slope and an increasing of put-on, take-off time differences. The case $q_1 = q_2 = 3/4$ manifests a further increase in level and a tendency towards a slope as steep and uniform as the case of total reliance of external memory.

If we suppose that the effect of computation is to increase the "forgetting probabilities" q_1 and q_2 , while that of practice is to decrease these values, the features of the model curves are directly comparable to the results of Experiment A. Recall that the level and slope of the Experiment B curve (dependence upon external memory) were greater than the corresponding features of the curves of Experiment A. Similarly, the level and slope of SC curves were greater than those of NC curves. The effect of practice is to reduce these differences. Finally, we observed the marked zig-zag pattern of Experiment A curves as against the uniform slope of Experiment B curves. This difference is a result of the different values assumed by parameters q_1 and q_2 in the two cases, as well as the 0.06 sec constant we imposed.

It should be noted that the probabilities assumed are a simplified description of the effects of dating in the retrieval process. Also, the linear dependence of internal retrieval times on list state is a simplified description of the retrieval process.

The initial tendency for SC curves to cross the Experiment B curve is probably due to incomplete establishment of the retrieval process strategy. The role of practice or learning in establishing the subjects strategy remains for further investigation.

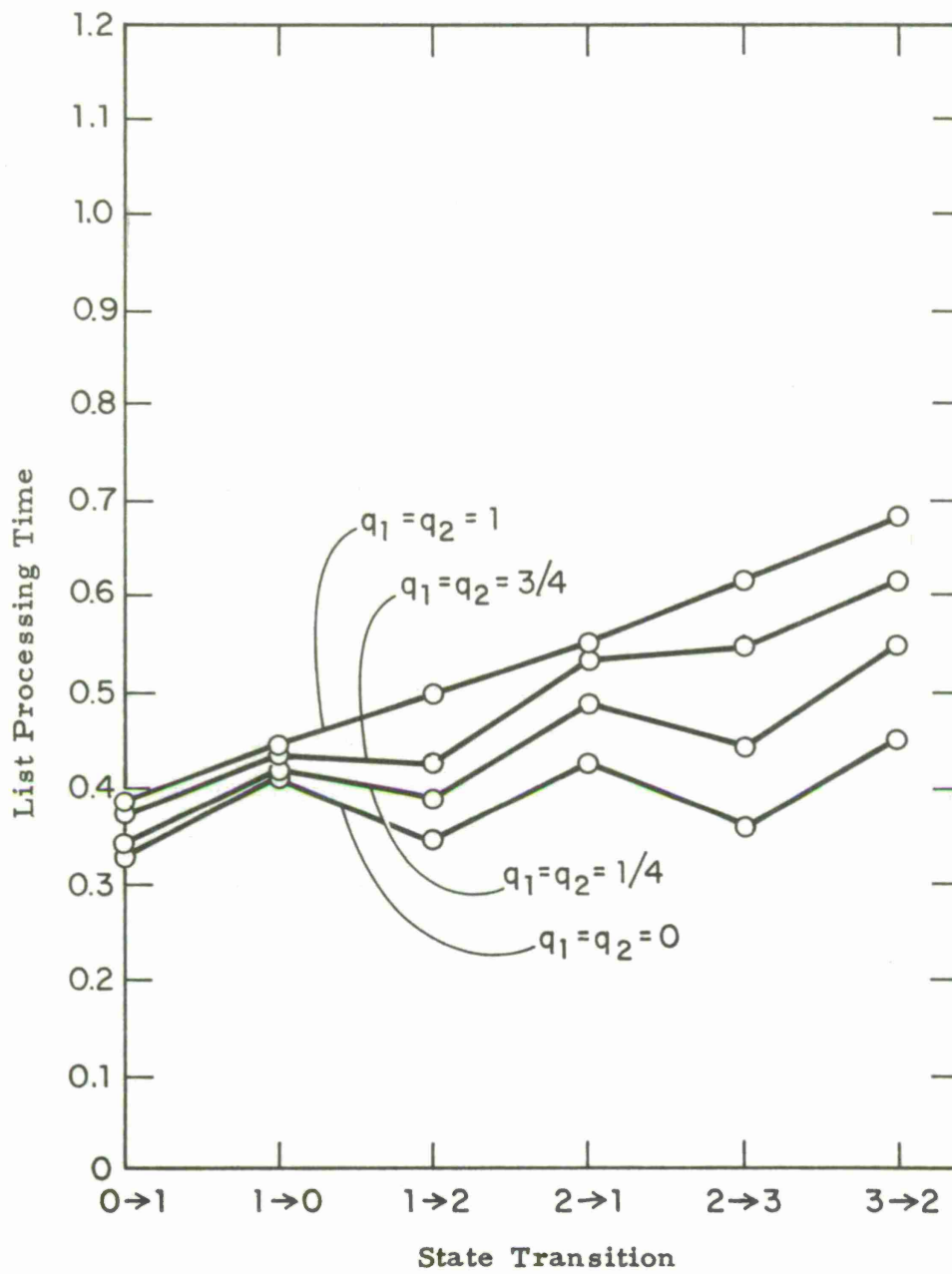

Fig. 9. List Processing Times Predicted by Retrieval Model.

5. RESULTS OF EXPERIMENTS C AND D, AND A RELEVANT MODEL

5.1. Location-Item Chunk Storage

In the previous section we presented a model for human storage and retrieval of information in performing the experimental task. The model postulated use of a definite form of associative storage referred to as item storage. To test the effect of use of other forms of storage, Experiments C and D were devised in which subjects were instructed to attempt 'forced updating.

We postulate that forced updating requires what we shall call "location-item chunk storage." As shown in Fig. 7 item-location pairs are unitized and are memorized as a string. In contrast to item storage, location-item chunk storage establishes memory of the present state of a list independently of its past history.

5.2. Results of Experiments C and D. Effect of Replacing or Supplementing Item Storage.

Fig. 10 presents graphs of "updating time" measured in Experiments A, C and D, and averaged over the list state established in the cycle. Update times for C and D increase with list state. This is to be expected since the amount of processing required by location-time chunk storage is directly dependent on list state, i. e., the number of items presently on the list. It will be recalled that Experiment A imposed no particular update procedure on the subject. Comparison of update intervals measured in A show less tendency to increase with list state.

Fig. 11 presents graphs of item processing time of Experiments A, C and D and averaged over the list state of the previous cycle. It is found that item processing times also increase with list state. Since as just noted, update processing increases with list state, it may be concluded that item processing time increases with the amount of updating performed on the list of the previous cycle.

Fig. 12 presents graphs of list processing time averaged over the state transition effected during the cycle. Comparison of curves for Experiment C with those of B and A, indicates that retrieval time required by location-item chunk storage is generally greater than that required for retrieval from external location storage

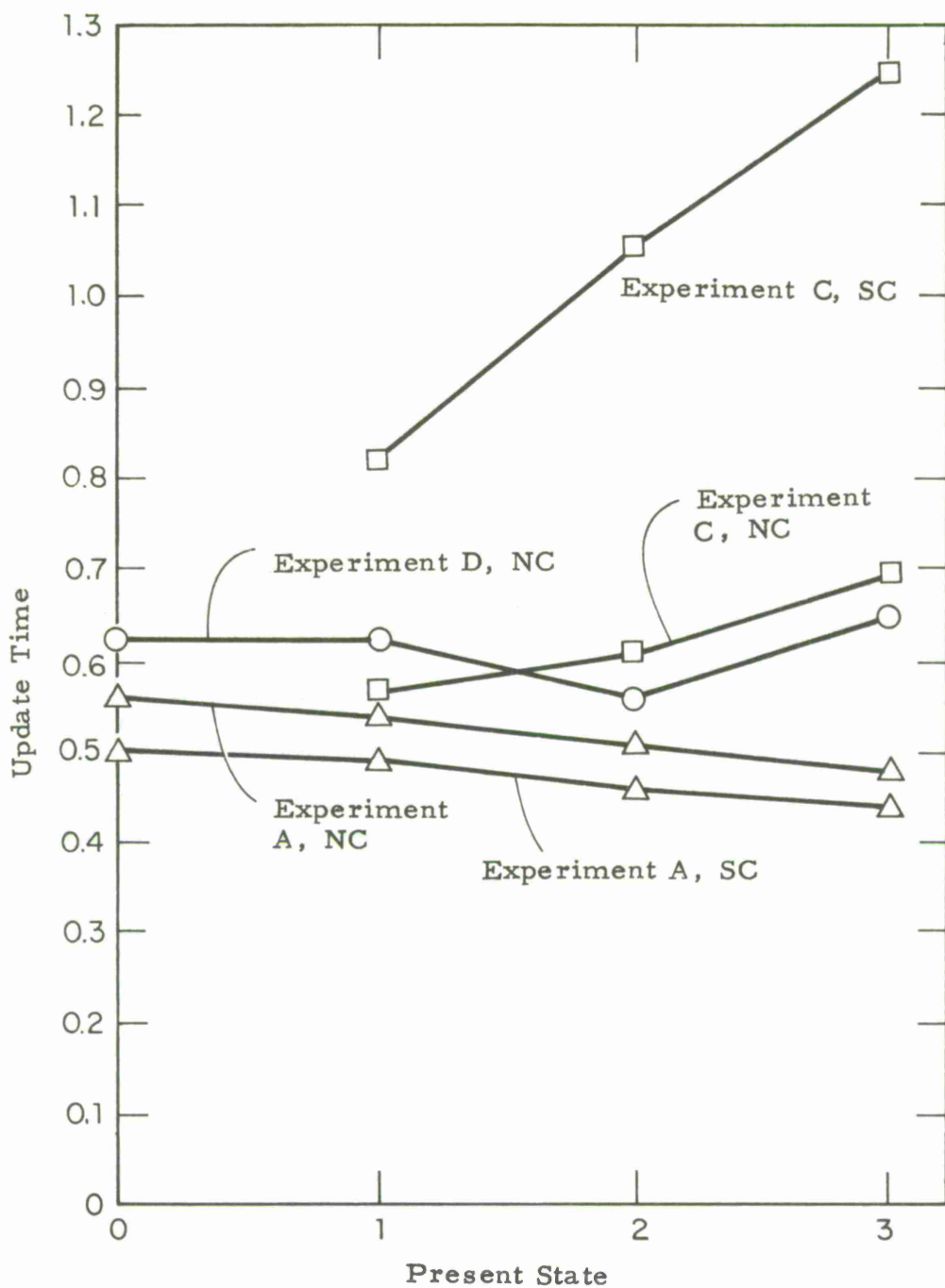

Fig. 10a. Effects of Forced and Free Update Procedures, Subject MR.

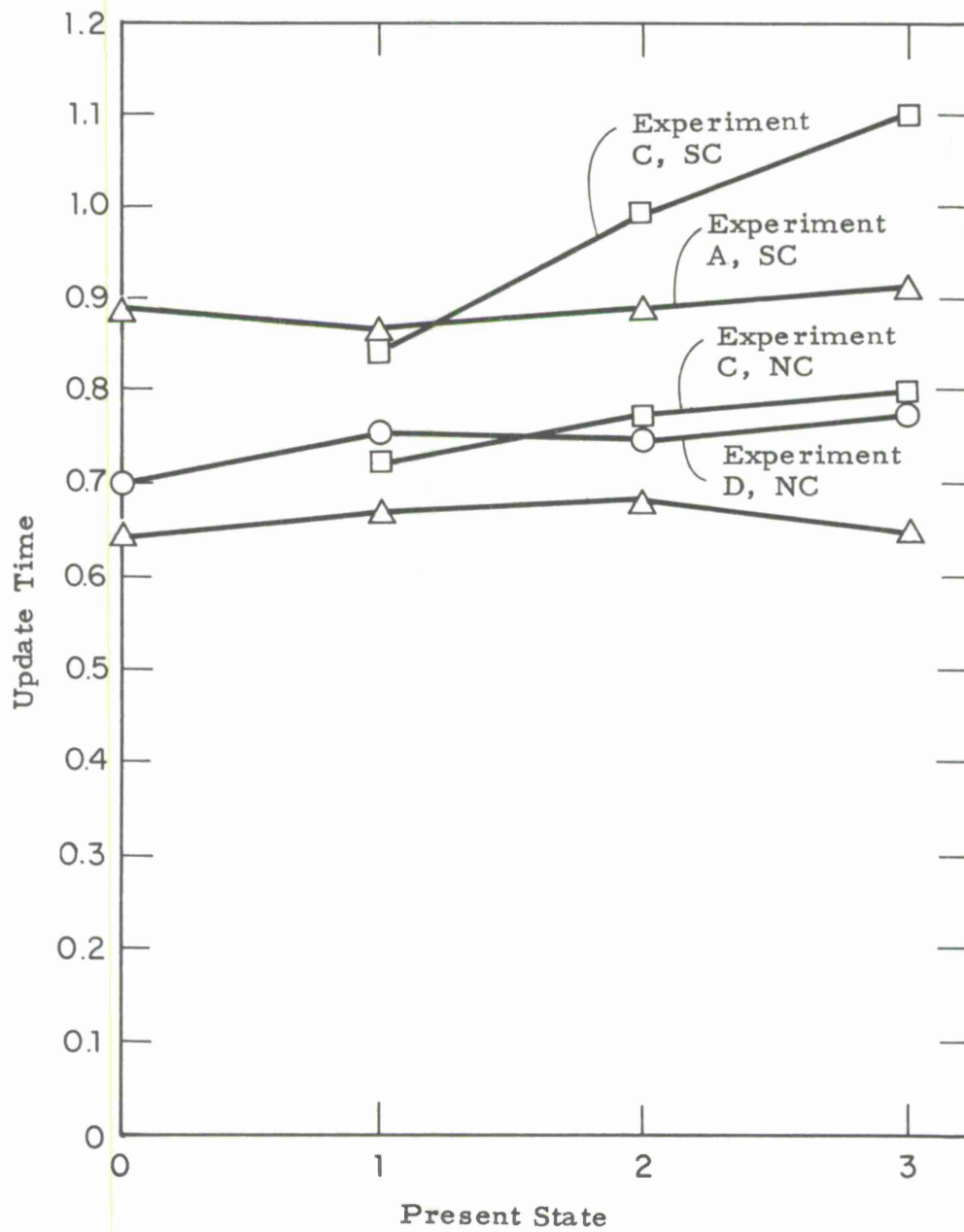

Fig. 10b. Effects of Forced and Free Update Procedures, Subject RF.

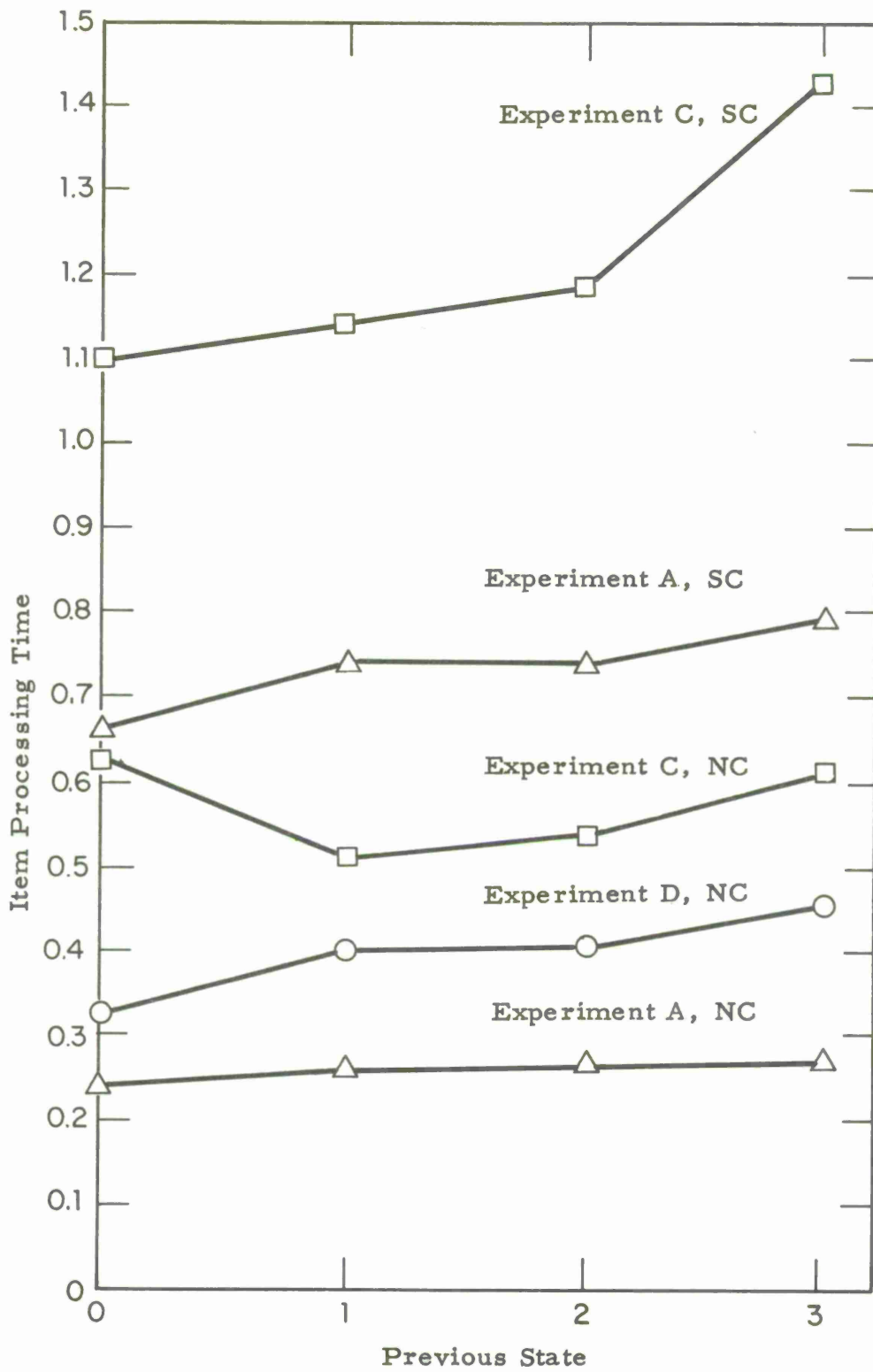

Fig. 11a. Effects of Update Procedures, Subject MR.

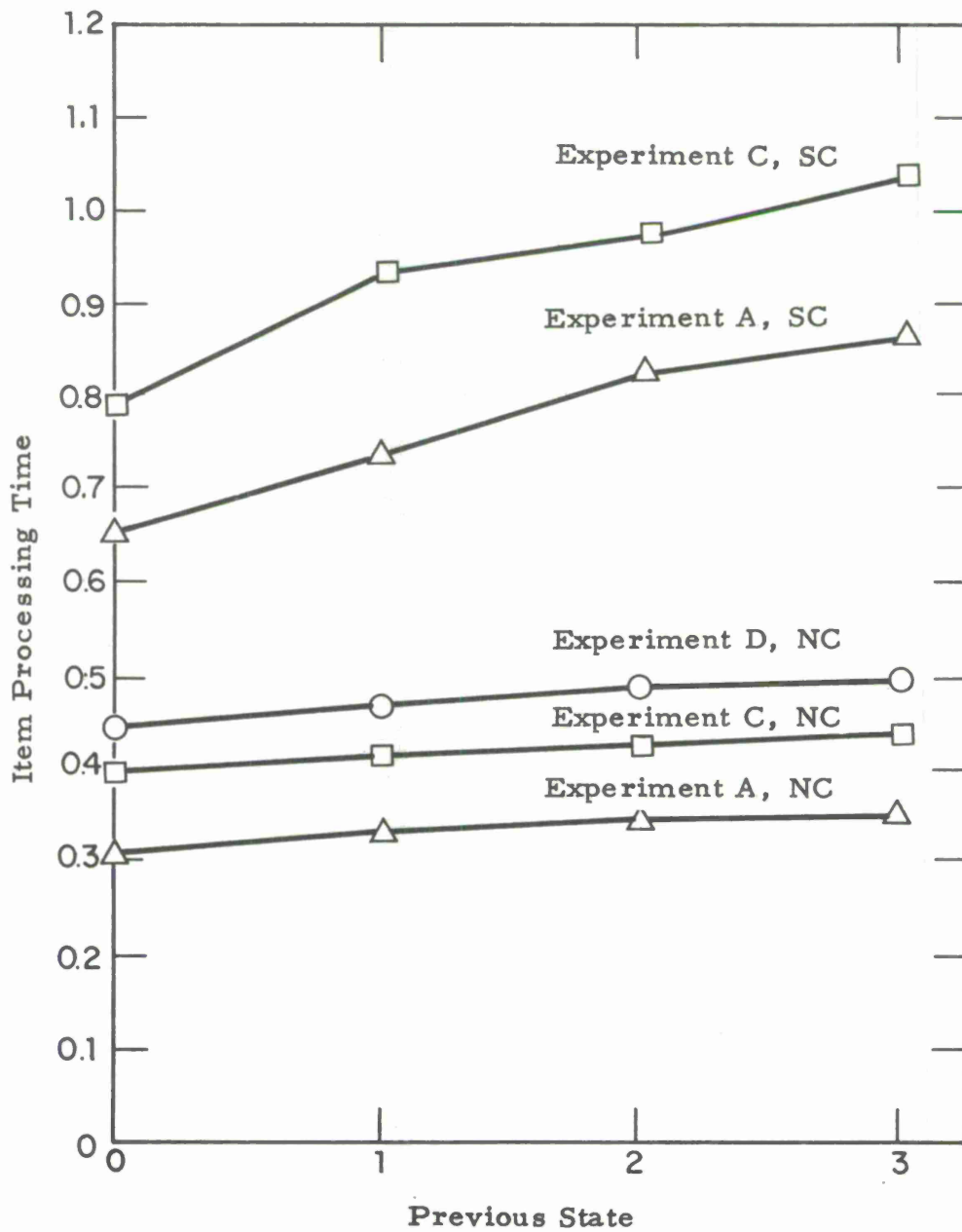

Fig. 11b. Effects of Update Procedures, Subject RF.

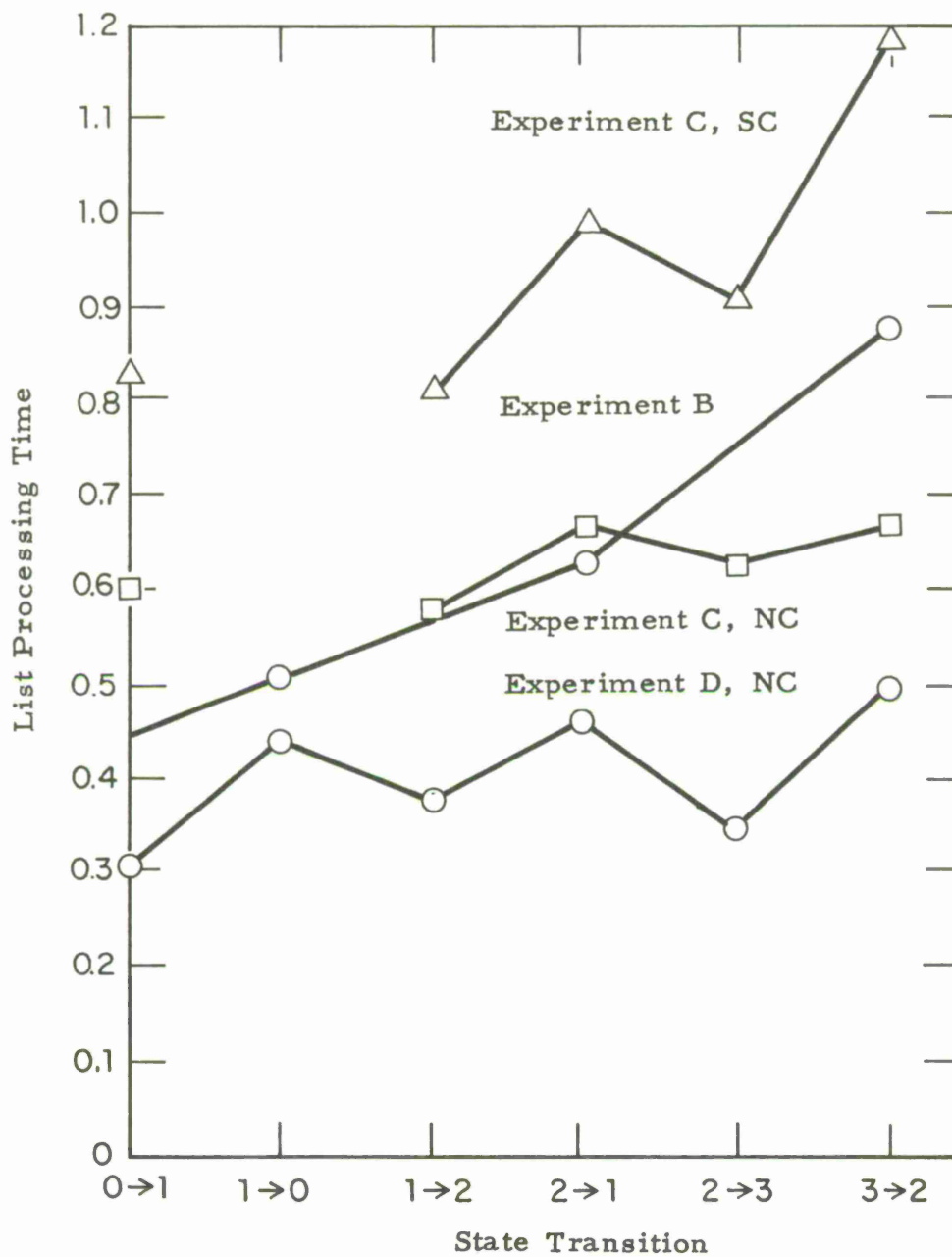

Fig. 12a. Effects of Forced Updating, Subject MR.

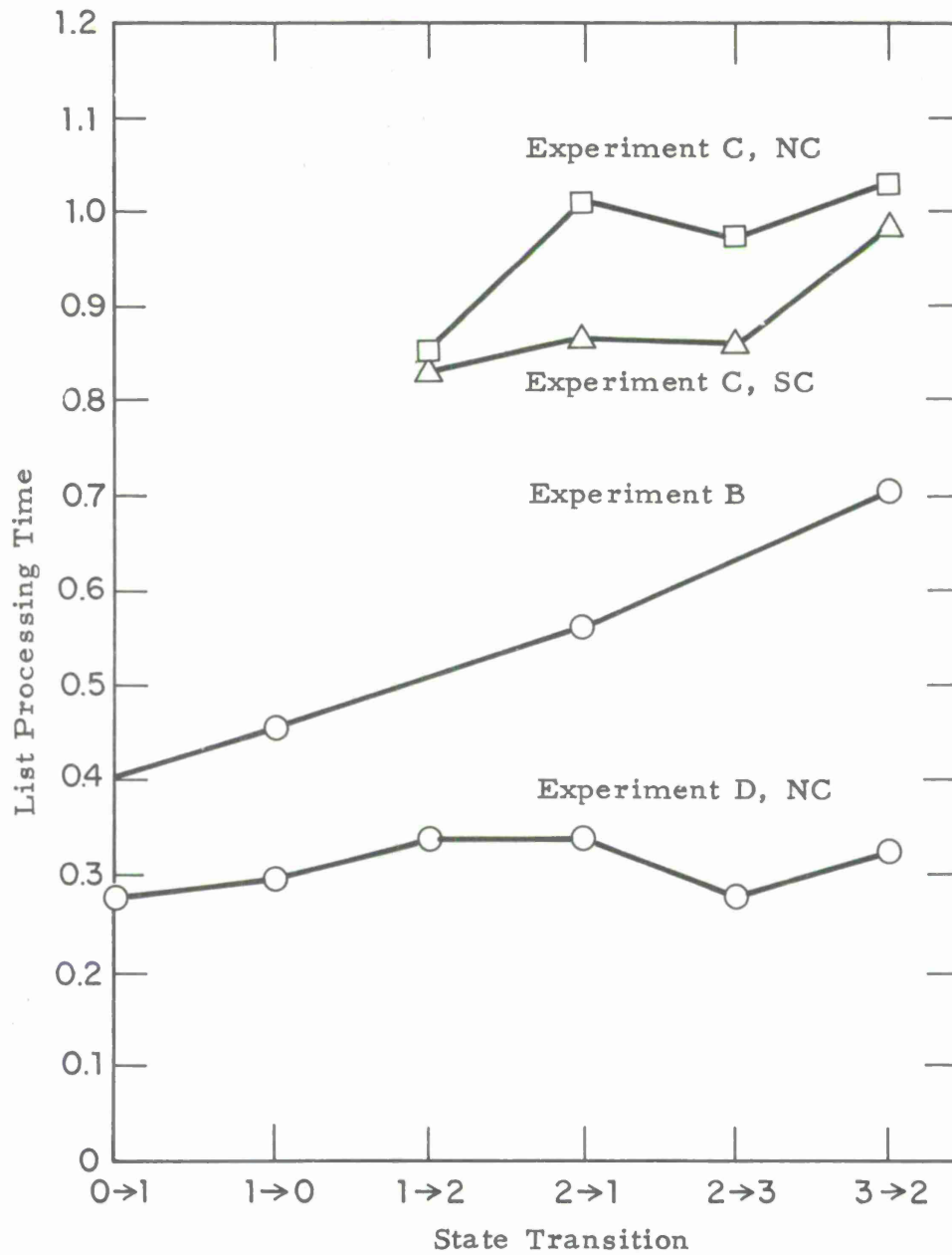

Fig. 12b. Effects of Forced Updating, Subject RF.

and certainly greater than that required by item storage. Comparison of curves of D with those of A (Fig. 5) indicate that the extra processing involved in forced updating does not result in significant improvement in list processing performance.

Results generally suggest that introduction of extra processing operations such as computation or forced updating tends to increase time required for independent operations already existing in the cycle. For example, computation generally increases list processing as well as update time; forced updating increases item processing time by amounts dependent on the amount of processing involved in the update interval.

6. CONCLUSIONS

Storage. A particular form of associative structure referred to as item storage was postulated as characteristic of human or internal memory in this task, and subsequently shown to be consistent with experimental results. This structure encodes information in the order in which processing operations are attended to. By contrast, location storage was shown to be characteristic of the external memory established by the console. The memory required by the task did not exceed immediate memory capacity, but dating of cues could account for memory loss.

Retrieval. A retrieval model implied by the item storage structure of human memory was developed to account for experimental results. Retrieval of information is faster from internal human memory than from external console memory. The probabilities of insufficient item recognition and insufficient location retrieval from internal memory increase with computation and decrease with practice. Correspondingly, the relative use of external console memory increases as these probabilities increase.

Optimality. The attempt to supplement item storage with location-item chunk updating does not produce any significant improvement of list processing performance. Furthermore, the extra processing involved tends to increase the times necessary for other operations. Also, location-item chunk retrieval is considerably slower than normal retrieval. Thus the normal modes of storage and retrieval seem to be optimal at least in this task.

We have used the underlying principle that the manner in which information is stored in human memory determines the manner in which it may be retrieved and the basic assumption that the storage structures normally set-up in human memory are fashioned by the order in which information is attended to. Both ideas have implications for general console design as it affects the human processor. For example, information handling procedures may be unwittingly forced upon the operator by the design of the console and the sequence in which information is presented. Internal storage structures so established may be efficient in response to certain questions but ill-suited in answer to others.

7. REFERENCES

1. Shepard, R.N., and Teghtsoonian, M., "Retention and Information under Conditions Approaching a Steady State," J. Exp. Psychol., 1961, Vol. 62, pp. 302-309.
2. Lloyd, K.E., Reid, L.S., and Feallock, J.B., "Short-Term Retention as a Function of the Average Number of Items Presented," J. Exp. Psychol., 1960, Vol. 60, pp. 201-207.
3. Yntema, D.B., and Mueser, G.E., "Remembering the Present States of a Number of Variables," J. Exp. Psychol., 1960, Vol. 60, pp. 18-22.
4. Newell, A., and Simon, H.A., "Computer Simulation of Human Thinking," Science, 1961, Vol. 134, pp. 2011-2017.
5. Feigenbaum, E.A., The Simulation of Verbal Learning Behavior, RAND Corp. Report P-2235, 1961.
6. Miller, G.A., "The Magical Number Seven Plus or Minus Two: Some Limits on Our Capacity for Processing Information," Psychol. Rev., 1956, Vol. 63, pp. 81-97.
7. Averbach, E., "Reading Out the Visual Buffer Storage," Paper presented at the 1962 meetings of AAAS, Philadelphia, Penn.
Averbach, E., and Coriell, A.S., "Short-Term Memory in Vision," Bell Syst. Tech. J., 1960, Vol. 40, pp. 309-328.
8. Sperling, G., "A Model for Visual Memory Tasks," Human Factors, 1963, Vol. 5.
9. Peterson, L.R., "Immediate Memory: Data and Theory," In C.M. Cofer (ed), Verbal Learning and Behavior: Problems and Processes, New York, McGraw-Hill, 1963.
10. Murdock, B.B., Jr., "The Retention of Individual Items," J. Exp. Psychol., 1961, Vol. 62, pp. 618-625.
11. Melton, A.W., "Comments on Professor Peterson's Paper," In C.M. Cofer (ed), Verbal Learning and Behavior: Problems and Processes, New York, McGraw-Hill, 1963.

12. Broadbent, D.E., and Gregory, M., "On the Recall of Stimuli Presented Alternately to Two Sense-Organs," Quart. J. Exp. Psychol., 1961, Vol. 13, pp. 103-109.
13. Pollack, I., Johnson, L.B., and Knaff, P.R., "Running Memory Span," J. Exp. Psychol., 1959, Vol. 57, pp. 137-146.

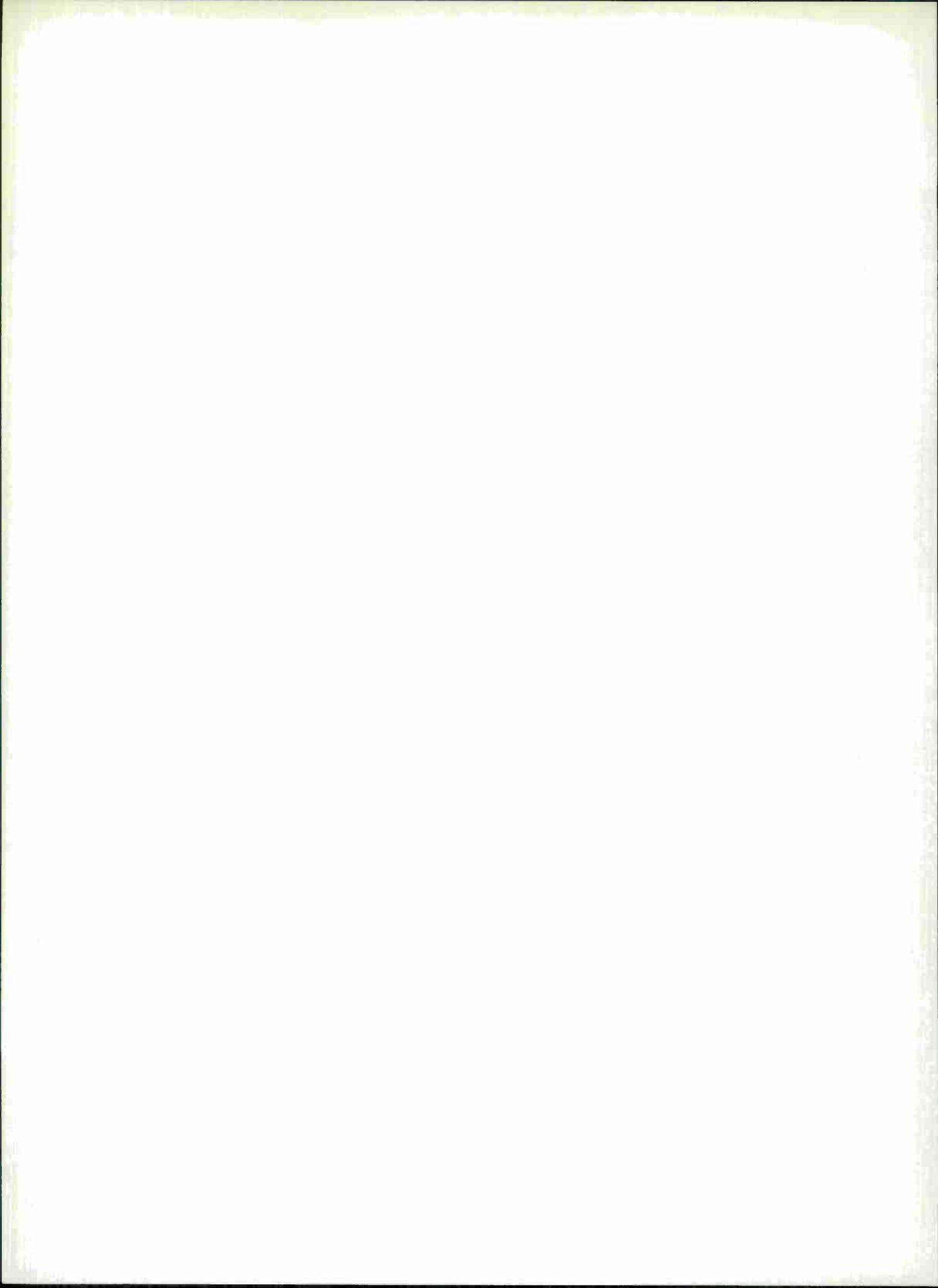

DOCUMENT CONTROL DATA - R&D

(Security classification of title, body of abstract and indexing annotation must be entered when the overall report is classified)

1. ORIGINATING ACTIVITY (Corporate author) Engineering Projects Laboratory, Department of Mechanical Engineering, Massachusetts Institute of Technology.		2a. REPORT SECURITY CLASSIFICATION Unclassified	
		2b. GROUP n/a	
3. REPORT TITLE Human Use of Short Term Memory in Processing Information on a Console			
4. DESCRIPTIVE NOTES (Type of report and inclusive dates) None			
5. AUTHOR(S) (Last name, first name, initial) Zeigler, B. P., Sheridan, T. B.			
6. REPORT DATE September 1964		7a. TOTAL NO. OF PAGES	7b. NO. OF REFS 13
8a. CONTRACT OR GRANT NO. AF 19 (628)-3317		9a. ORIGINATOR'S REPORT NUMBER(S) ESD-TDR-64-620	
b. PROJECT NO. 7682		9b. OTHER REPORT NO(S) (Any other numbers that may be assigned this report) DSR 9960-1	
c.			
d.			
10. AVAILABILITY/LIMITATION NOTICES Qualified requesters may obtain from DDC. DDC release to OTS Authorized.			
11. SUPPLEMENTARY NOTES None		12. SPONSORING MILITARY ACTIVITY Decision Sciences Laboratory, Hq ESD, L. G. Hanscom Field, Bedford, Massachusetts	
13. ABSTRACT This report assumes that an operator's console constitutes a third form of memory in addition to that integral to the human and that integral to the machine which is not directly accessible to the human. Questions are raised concerning the characteristic modes of human storage and retrieval of information from internal memory when such external memory is accessible. The report also introduces the concept of associative memory nets formed by cue-related images of external events. Information loss occurs when cues, originally capable of providing access to images, become insufficient to direct retrieval, in subsequent memory growth. A list processing experiment is described. The processing involves adding or removing sequentially presented "items" (alphanumeric characters) from a list of previously processed items. Two conditions are established in which items are 1) presented directly, or 2) computed from presented data. Storage structures characterizing internal human memory and external console memory in this task are postulated. A retrieval model implied by these structures is constructed to account for the effects of computation and learning upon the features from internal memory is assumed to necessitate external memory search. The effect of computation is to increase the probability of insufficient retrieval and hence the frequency of external search. Learning decreases this probability. The effects of inducing alternate forms of internal storage are studied and found generally to result in increased storage and retrieval times. Implications for console design are discussed.			

Security Classification

14. KEY WORDS	LINK A		LINK B		LINK C	
	ROLE	WT	ROLE	WT	ROLE	WT
1. Decision Making 2. Human Engineering 3. Information Retrieval 4. Models 5. Memory 6. Computer Console 7. Data Storage Systems 8. Data Processing Systems						

INSTRUCTIONS

1. **ORIGINATING ACTIVITY:** Enter the name and address of the contractor, subcontractor, grantee, Department of Defense activity or other organization (*corporate author*) issuing the report.
- 2a. **REPORT SECURITY CLASSIFICATION:** Enter the overall security classification of the report. Indicate whether "Restricted Data" is included. Marking is to be in accordance with appropriate security regulations.
- 2b. **GROUP:** Automatic downgrading is specified in DoD Directive 5200.10 and Armed Forces Industrial Manual. Enter the group number. Also, when applicable, show that optional markings have been used for Group 3 and Group 4 as authorized.
3. **REPORT TITLE:** Enter the complete report title in all capital letters. Titles in all cases should be unclassified. If a meaningful title cannot be selected without classification, show title classification in all capitals in parenthesis immediately following the title.
4. **DESCRIPTIVE NOTES:** If appropriate, enter the type of report, e.g., interim, progress, summary, annual, or final. Give the inclusive dates when a specific reporting period is covered.
5. **AUTHOR(S):** Enter the name(s) of author(s) as shown on or in the report. Enter last name, first name, middle initial. If military, show rank and branch of service. The name of the principal author is an absolute minimum requirement.
6. **REPORT DATE:** Enter the date of the report as day, month, year; or month, year. If more than one date appears on the report, use date of publication.
- 7a. **TOTAL NUMBER OF PAGES:** The total page count should follow normal pagination procedures, i.e., enter the number of pages containing information.
- 7b. **NUMBER OF REFERENCES:** Enter the total number of references cited in the report.
- 8a. **CONTRACT OR GRANT NUMBER:** If appropriate, enter the applicable number of the contract or grant under which the report was written.
- 8b, 8c, & 8d. **PROJECT NUMBER:** Enter the appropriate military department identification, such as project number, subproject number, system numbers, task number, etc.
- 9a. **ORIGINATOR'S REPORT NUMBER(S):** Enter the official report number by which the document will be identified and controlled by the originating activity. This number must be unique to this report.
- 9b. **OTHER REPORT NUMBER(S):** If the report has been assigned any other report numbers (*either by the originator or by the sponsor*), also enter this number(s).
10. **AVAILABILITY/LIMITATION NOTICES:** Enter any limitations on further dissemination of the report, other than those

imposed by security classification, using standard statements such as:

- (1) "Qualified requesters may obtain copies of this report from DDC."
- (2) "Foreign announcement and dissemination of this report by DDC is not authorized."
- (3) "U. S. Government agencies may obtain copies of this report directly from DDC. Other qualified DDC users shall request through _____."
- (4) "U. S. military agencies may obtain copies of this report directly from DDC. Other qualified users shall request through _____."
- (5) "All distribution of this report is controlled. Qualified DDC users shall request through _____."

If the report has been furnished to the Office of Technical Services, Department of Commerce, for sale to the public, indicate this fact and enter the price, if known.

11. **SUPPLEMENTARY NOTES:** Use for additional explanatory notes.
12. **SPONSORING MILITARY ACTIVITY:** Enter the name of the departmental project office or laboratory sponsoring (*paying for*) the research and development. Include address.
13. **ABSTRACT:** Enter an abstract giving a brief and factual summary of the document indicative of the report, even though it may also appear elsewhere in the body of the technical report. If additional space is required, a continuation sheet shall be attached.

It is highly desirable that the abstract of classified reports be unclassified. Each paragraph of the abstract shall end with an indication of the military security classification of the information in the paragraph, represented as (TS), (S), (C), or (U)

There is no limitation on the length of the abstract. However, the suggested length is from 150 to 225 words.

14. **KEY WORDS:** Key words are technically meaningful terms or short phrases that characterize a report and may be used as index entries for cataloging the report. Key words must be selected so that no security classification is required. Identifiers, such as equipment model designation, trade name, military project code name, geographic location, may be used as key words but will be followed by an indication of technical context. The assignment of links, rules, and weights is optional

